



# MIT Sloan School of Management

**Working Paper 4444-03  
July 2003**

## **IT/Automation Cost Reduction in Intel's Manufacturing Environment**

Brian Subirana

© 2003 by Brian Subirana. All rights reserved. Short sections of text, not to exceed two paragraphs, may be quoted without explicit permission, provided that full credit including © notice is given to the source.

This paper also can be downloaded without charge from the  
Social Science Research Network Electronic Paper Collection:

<http://ssrn.com/abstract=469282>

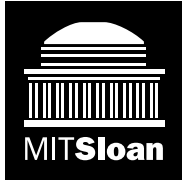

## IT/Automation Cost Reduction in Intel's Manufacturing Environment<sup>1</sup>

### Introduction:

In late July 2002, Chip Hendry, Vice President of Intel in charge of Manufacturing had a discussion with Sally Conn, Vice President of Intel in charge of Central Engineering, about the high computing costs and spending at Intel.

“We have over 1,000 people working on computing within our semiconductor operations alone. This is on top of over 4,000 people working in Information Technology within Intel. There has got to be significant overlap within these organizations. Every factory has their computing group in addition to local IT organizations at each factory. We have got to find a way to achieve synergy and dramatically reduce our cost of computing.”

From that discussion they called a meeting with participants from the various manufacturing computing groups at Intel. At the meeting Chip Hendry and Sally Conn challenged the group to find ways to reduce computing spending within the manufacturing environment by 30% to 50% in the next eighteen months. Sally Conn's challenges were to reduce cost while maintaining existing service levels.

“We want you to reduce automation costs by 50% while maintaining equal or better service to the factories. There appear to be many duplicate silos of computing competency. Let's gain efficiency by pooling a set of resources that can be optimized.”

---

<sup>1</sup> © **Note:** This fictional case study was originally written by Stan Stanzyk and Tee Welton under the supervision of Prof. Brian Subirana for an MIT Leaders For Manufacturing class on Information Technology as an Integrating force in Manufacturing. The study includes public domain data on revenues, earnings, and employment for Intel Corporation. All other data, names and facts are artificial and intended to help educate students on dealing with Information Technology management challenges. In particular all headcount and cost numbers referred to in this case study are fictional and do not reflect actual Intel headcount or spending.

“Start small and show efficiency in your own areas quickly. Then use this as a role model for other groups within Technology and Manufacturing. Look for total cost of ownership reduction, include suppliers, leverage low cost centers such as India, etc.”

Chip Hendry challenged the group to look for efficiencies across organizations and geographies. He asked the group to find innovative ways to reduce computing costs by looking throughout the automation life cycle, from capability definition through implementation and long-term support.

“I don’t think current service level is a boundary condition for cost reduction. In our current business environment we need to ask the question why are we always upgrading/updating something. Why can’t we freeze applications or capability to keep our costs down?”

“Look at 80/20 culture in terms of end user capabilities. What do the customers need the most?”

“Spend some time understanding what the hurdles are with this effort, why has this not worked in the past? Don’t jump immediately to solution space. Dig deeper than deck chair org changes ... Focus on meaningful changes which lead to meaningful efficiency gains.”

Considerable time at the meeting was spent discussing the scope of the cost reduction effort, what organizational groups should be included. It was decided to focus on the three groups represented at the meeting: Manufacturing Computing, Information Technology, and Central Engineering. Another focus would be on ways to leverage the suppliers that support our computing capabilities. The group decided to keep design and development out of the initial focus but realized that at some point they would have to come into the scope. One of the challenges discussed was buy-in of the factory managers at each site. Since the computing headcount in the factories reports directly to them, they may have issues with a perceived loss of control. The group agreed that Chip Hendry needed to identify a champion to lead a computing cost reduction team, which will drive this effort. Chip Hendry and Sally Conn wanted the team to work quickly to develop proposals on how to reach the cost goals. The team would come back in one month with options.

Shortly after the meeting, Chip Hendry announced that a new position – Computing Cost Reduction Manager - was created to lead the team to drive the cost reduction efforts and Mike Ronne would fill that position. The computing cost reduction team’s task was to come up with specific recommendations on how to achieve the cost goals established by Chip Hendry and Sally Conn and report out on a strategy in the next two weeks.

## **Intel Business Environment:**

Exhibit 1 and 2 show 1999 through 2001 quarterly business results. Revenues and net income had declined sharply from a peak in 2000. For 2002, they were well below 1999 levels while total Intel headcount remained 15,000 employees higher than it was in 1999. One key measure of productivity, revenue per employee had dropped approximately 30% from 2000. That tough business climate was driving significant cost reduction in the company, as no economic turnaround was in sight. It appeared there had been a fundamental shift in the business climate that required aggressive cost discipline as a way of life. This in part was driven by the continued commoditization of CPU's and the success of low cost Asian semiconductor foundries. The CPU business was becoming more like Intel's FLASH memory business, which was highly cost sensitive.

To help reduce the cost of both CPU and FLASH microchips, Intel had just employed a new manufacturing technology. Microchips were manufactured in bulk, through the use of silicon wafers. Each wafer contained hundreds of microchips that are smaller than the size of a person's thumbnail. The cost of manufacturing microchips was directly related to the size of the wafers that the microchips are produced on. Until 2002, most manufacturing facilities at Intel employed the use of 200mm (8-inch) wafers. A silicon wafer this size allowed for approximately 200 square inches of surface area to build microchips on. To reduce the cost of microchip manufacturing, Intel had just built the first few 300mm (12 inch) wafer factories. By doing this, Intel could increase the surface area of the wafer by 225%, to 450 square inches, which allowed many more units to be produced per wafer for a minimal additional cost. Implementing 300mm technology in factories results in a 30% unit cost reduction relative to 200mm factories.

### **Computing Environment within Intel Manufacturing:**

During the initial cost reduction team meetings, the organization and business processes were examined. Intel manufacturing relied heavily on IT and Factory Automation during the manufacturing processes. At Intel, everything from scheduling products on the floor and product delivery systems to statistical process control was done through automation systems. The semiconductor manufacturing process had been very sensitive to particle contamination - one microscopic particle could destroy a chip and make it scrap. An advantage of Intel's automation systems had been that it minimized interaction between technicians and the product, thus cutting the possibility of particle contamination. The downside of this was Automation system support had become critical to manufacturing operational health. If an Automation system went down, it could cripple a factory until that system was brought back online. Given these factors, traditional investment in IT and Automation systems as well as manufacturing IT support has been high at Intel.

Structurally, Intel had three primary computing groups in the manufacturing environment. These were Manufacturing Computing (MC), Information Technology (IT), and Central Engineering (CE). A description of these groups is shown in exhibit 3. Each factory automation department consisted of all the domains shown in exhibit 3. The tasks performed in each factory were essentially the same as those performed in any other Intel factory. There were differences in headcount based on complexity and size of the factory. Local IT groups also had a similar structure in each factory. They supported the local area network and all "office" servers including email and data storage. In addition to the

local IT group there was a central IT organization that supports all enterprise wide applications remotely. IT call centers were located in low cost geographies while each factory automation group had a local help desk at the site. Most of the IT technical engineering support was located in Folsom, California. The CE structure was similar to the factory automation structure. Their role however was primarily development of new computing applications needed for next generation semiconductor process technologies. They worked closely with Intel's automation development group in Oregon on those new applications. They also managed our corporate contracts with computing suppliers. Exhibit 4 shows a high-level bubble diagram of what the various computing groups looked like at Intel. This shows factory automation groups, IT, CE, and other smaller computing groups. Exhibit 5 shows all the locations of Intel's manufacturing sites.

A key business process for Intel was "Copy Exactly!" When a new process was transferred from the development site, the production factory replicated the same processes, tools, and conditions that the development factory uses. From an automation perspective that applies to the physical hardware, software applications, and even maintenance procedures. In essence, when an automation change was approved for implementation, the Automation support organizations from each site running that process would implement the change locally. The "Copy Exactly!" environment facilitates consistency from factory to factory in the results achieved and in the problems seen. When one factory had a problem, it was only a matter of time before another factory would see the same problem. There was an initial cost associated with "Copy Exactly!" that was made up during a process lifetime through improved quality and faster problem resolution. There was an evolution to "Copy Exactly!" that allowed for more mature factories to focus on cost reduction. Exhibit 6 shows these phases and how a cost focus could be applied as a factory matures. Most of the 200mm factories at Intel were moving to Phase 3 while the new 300mm factories are still in phase 1.

## **Data Analysis:**

The team spent the first month analyzing the various cost components within manufacturing related to computing. This included the costs of each factory automation group, costs of the CE organization, and costs of the IT organization. IT charged an allocation to each Intel business unit based on services consumed. A summary of the costs for each organization is shown in exhibit 7. The spending was broken out between 200mm manufacturing factories and 300mm manufacturing factories. Being an older process, the 200mm factories were more mature and would be phased out over time, while the 300mm factories were new and the number of 300mm factories would increase, as it became the new standard technology. Total planned spending for the three computing groups in 2003 will be \$272 million. The baseline for the cost reduction efforts was the actual spending in 2002. There was a revised spending amount shown for 2003 of \$244 million. That assumed the start of successful cost reduction efforts. Exhibit's 8 and 9 shows data on headcount for the three groups and how the headcount was expected to change over the next several years. The data shows a 2002 headcount of about 1,000 decreasing by 25% by 2005. This would be done through a dramatic decrease in 200mm headcount of almost 50% while 300mm headcount remained flat even though a new 300mm factory was assumed in the data in 2005. These headcount reductions could only come through a successful productivity and efficiency effort. The

extra headcount could be reallocated to other groups so the expertise is not lost or can defer outside hiring that was taking place. Exhibit 10 shows a breakout of non-capital computing spending for 2002. The data shows that 65% of factory automation spending was on headcount. The second largest category was office operations, which was annual software and hardware license and maintenance fees.

### **Computing Cost Reduction Team Options:**

The team developed two options for reducing the headcount related costs within the factory automation groups. One option was to consolidate computing services that lent themselves to being done remotely. There was an assumption that some economies of scale could be achieved by centralizing tasks. By using “centralized hubs,” the total central headcount needed to do the tasks would be less than the combined headcount in each individual factory. The extent to which this was possible determines how effective this option would be on reducing costs. The second choice was for each factory to locally optimize their headcount without consolidating services across factories. They would maintain control of the services they provided and decide what areas they could shrink in and what services could be cut. The potential cost savings realized would depend on how aggressive the factories were with these choices. This would depend on the lifecycle of the factory, how old the factory was and what technologies they were running.

Exhibit 11 shows a model of locally optimized computing groups versus centrally optimized and where Intel’s factory computing groups were in 2002 on that scale. An analysis of centralization was done with results shown in exhibit 12. This shows the percent of tasks in each domain that could be done remotely or in a consolidated fashion. There was an estimate of potential headcount savings that could be realized through centralization of resources. Exhibit 13 shows a bubble diagram of how a centralized support structure might look.

An analysis was also done on locally optimizing headcount and services in each factory as an alternative to developing a central support system. Exhibits 14 and 15 show two case studies of potential headcount savings using this approach. A significant headcount reduction of up to 30% is shown as possible in this type of scenario. This option would allow each factory to be more or less aggressive based on their current and future roadmap. Those headcount savings would come mainly through the elimination of lower value added services to the factories.

Another alternative being explored was a hybrid option that combines both local headcount optimization and some centralization of key services. This was an attempt to look at scenarios that included aspects of both options to achieve optimal headcount efficiency.

There were other cost reduction opportunities beyond reducing headcount. These involved taking more risk on software and hardware maintenance agreements, consolidating hardware where possible, and reducing/eliminating on-call at the risk of increasing response times to problems. An analysis of these opportunities reveals savings in the range of \$10 million to \$15 million in 2003. As an example, each local automation

group and IT group had people that were “on-call”. These people were paid to be available off hours if a serious problem arises. In 2002, total spending for this on-call service was about \$3 million. Significant savings could be achieved if this “on-call” spending could be reduced or eliminated by simply taking more risk or using a follow the sun approach with our international factories.

Finally, exhibits 16 through 18 show various options for how Intel could manage the “centralized hubs” if they were chosen as one means of cost reduction. The options included various management structures within the manufacturing group (MC) and some included linkage to IT.

## **Computing Cost Reduction Team Report Out:**

As the leader of the computing cost reduction core team, Mike Ronne knew he had a large task. The group needed to evaluate the data on local optimization, centralization with hubs, and non-headcount related spending to determine what specific proposals should be made to senior management. Given Chip Hendry’s and Sally Conn’s goal to achieve a 30% to 50% cost reduction in computing spending over the next 18 months, significant questions needed to be answered.

First, given Intel’s environment, the team needed to assess the pros and cons for each headcount reduction option. Additionally, as noted, the team might be able to find other non-headcount spending reduction areas and assess if there is any risk in implementing them.

Given that analysis, the team would need to come up with a solid proposal to report back to Chip Hendry and Sally Conn, with clear goals and estimates for cost savings over the next few years. Chip and Sally would be interested in the benefits as well as the impacts of the proposal.

Mike Ronne had a few other concerns besides what the group would propose. Once the proposal gets approved, how would he implement such a large cost reduction strategy? How was he going to motivate the IT/computing groups within the manufacturing environment to get behind the cost cutting proposals and how can he keep morale high as the cost cutting plan is rolled out? Given the large dependence on automation and IT at Intel, it is critical that the factories continue to run well while these cost cutting activities are going on. This analysis and report out was a daunting task, but his team was ready to take on the challenge.

## Exhibit 1 Intel Revenue and Net Income

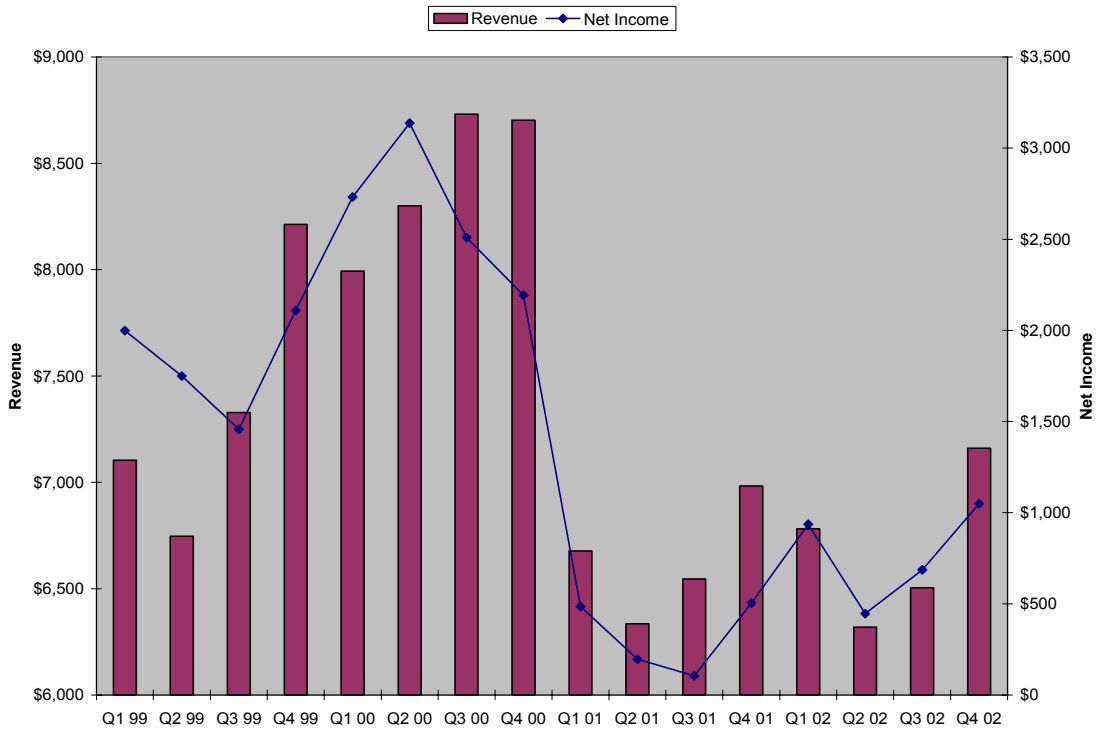
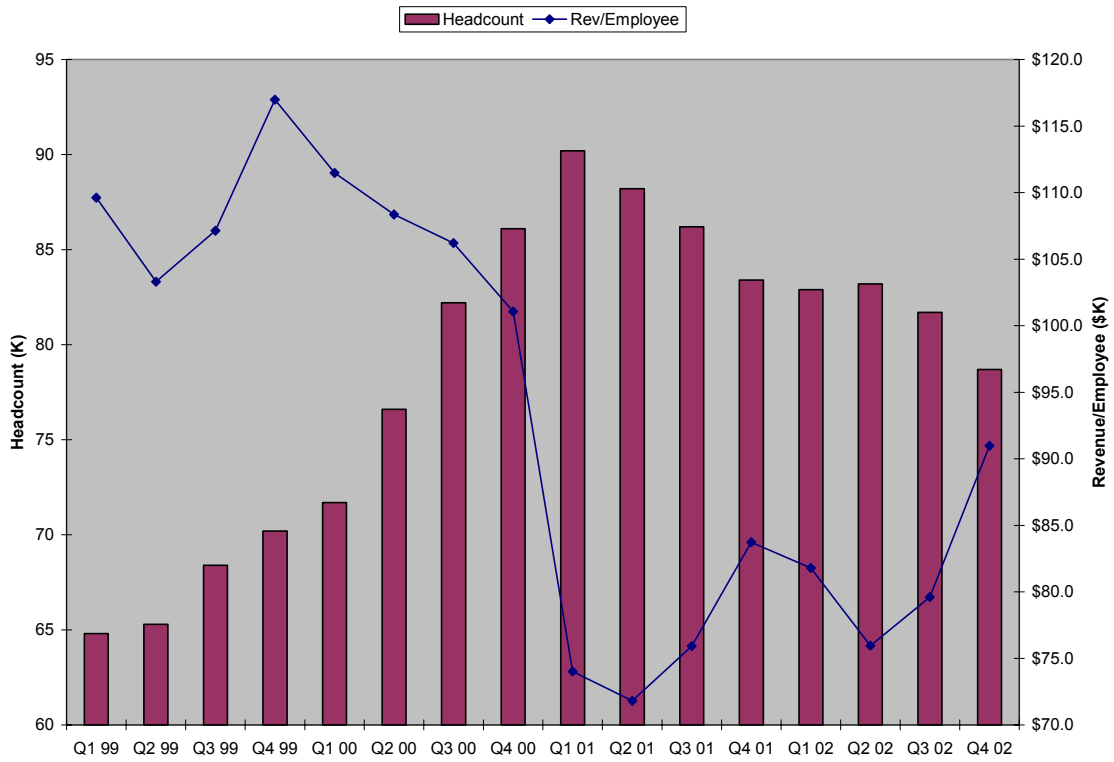

Exhibit 2  
Headcount and Revenue Per Employee





### Exhibit 3 Typical Computing Group Structure

Group	Function/Responsibility	Typical Headcount (large factory)
<b>Factory Computing Department</b>		
Staff/Admin	Management resources for the department	8
Decision Support Group	Provides reports on material in process, develops and supports data extracts from the Manufacturing Execution System. Provides web based applications for making real-time decisions on the manufacturing floor.	7
Infrastructure	Provides the hardware and operating system support for the infrastructure used in the manufacturing clean room. Support multiple O/S and H/W systems.	15
DataBase	Support all databases used by the factory. Includes SQL and Oracle in addition to legacy database systems. Perform all maintenance and sustaining.	4
Help Desk	First line of support for any computing problems in the factory. Escalate problems as needed to automation engineers. Covers 24x7.	15
Manufacturing Execution Systems	Supports and maintains the shop floor control system that manages all in-process inventory. Support and develop applications to meet new manufacturing requirements.	23
Material Handling	Support and maintain all automated systems used to move inventory from point A to point B in the factory.	11
Sort Automation	Maintains the computing systems used in the semiconductor test floor.	7
	Total Factory Automation Headcount	90
<b>Local IT Department</b>		
IT Server	Support the local IT servers, email Outlook/Exchange servers, database servers, etc.	3
IT Network	Provide support for both local area and wide area networks.	7
IT Telecommunications	Support all telephone and pager communications on the site.	3
	Total Local IT Support Headcount	13
<b>Central Engineering</b>		
Assembly/Test	Supports the Assembly/Test automation applications.	75
Fab/Sort	Supports new automation development, critical product support, supplier management.	150
Other	Administrative, corporate application support, info security.	75
	Total CAS Headcount	300

### Exhibit 4 Current Computing Organizational Structure

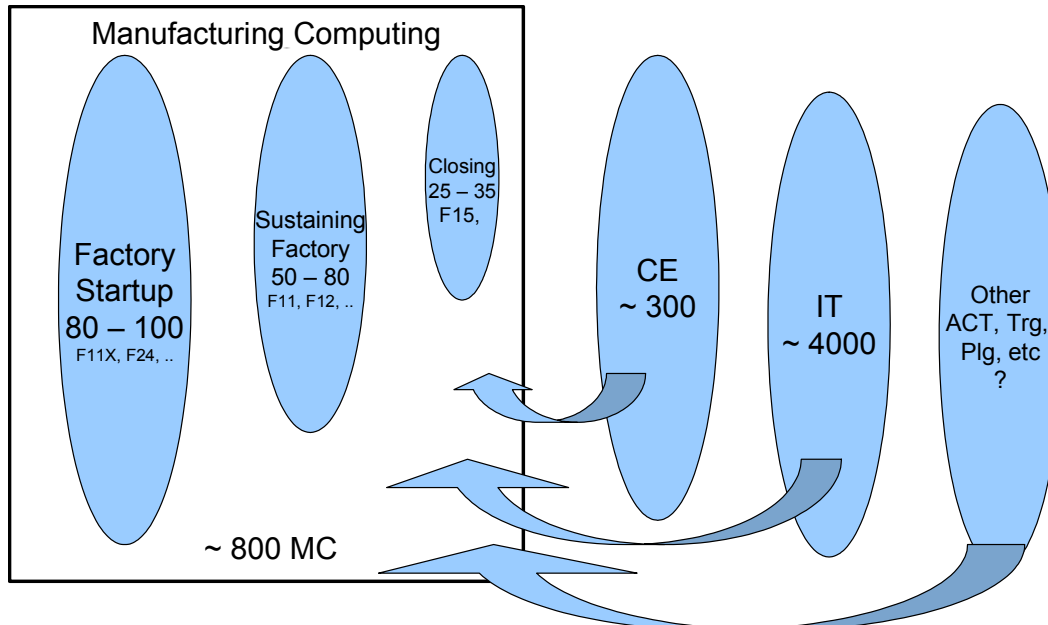

## Exhibit 5 Intel Manufacturing Locations

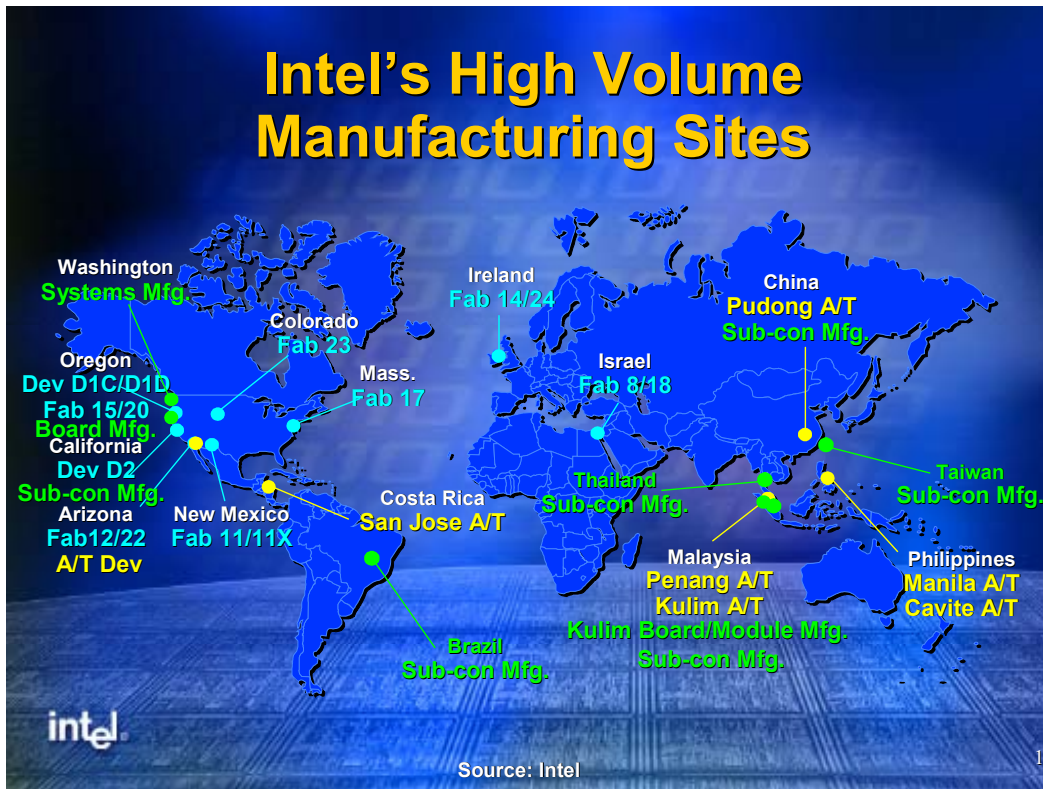

## Exhibit 6 Phases of “Copy Exactly!”

	Phase I	Phase II	Phase III
<b>General Description</b>	<ul style="list-style-type: none"> <li>Start Up</li> <li>Avoid Risk (at any cost)</li> <li>Installation</li> </ul>	<ul style="list-style-type: none"> <li>Volume</li> <li>Cost emerging priority</li> <li>Conversion of previous generation tool set.</li> </ul>	<ul style="list-style-type: none"> <li>Cost Focus</li> <li>Re-use/Re-deploy</li> </ul>
<b>Factory Characteristics</b>	<ul style="list-style-type: none"> <li>“Greenfield”</li> <li>1<sup>st</sup>, 2<sup>nd</sup> Factory</li> </ul>	<ul style="list-style-type: none"> <li>“Non-greenfield”</li> <li>Follow-on factories</li> </ul>	<ul style="list-style-type: none"> <li>Past capacity peak</li> <li>Factory consolidation</li> </ul>
<b>Product Line</b>	<ul style="list-style-type: none"> <li>Leading edge processors</li> <li>Sole Source</li> </ul>	<ul style="list-style-type: none"> <li>Mixed product line</li> <li>Cost emerging</li> <li>Product introductions</li> </ul>	<ul style="list-style-type: none"> <li>Cost emphasis on low margin/commodity products</li> </ul>
<b>CEI Policy/Purpose</b>	<ul style="list-style-type: none"> <li>Control/stability</li> <li>No excursions</li> </ul>	<ul style="list-style-type: none"> <li>Risk management</li> <li>Begin to see Fab-Fab differences</li> </ul>	<ul style="list-style-type: none"> <li>Loose collection of factories</li> <li>Synergy/sharing</li> </ul>
<b>JxM Focus</b>	<ul style="list-style-type: none"> <li>Yield</li> <li>Ramp; installation</li> <li>Technology stability</li> </ul>	<ul style="list-style-type: none"> <li>Yield</li> <li>Ramp; MOR attainment</li> <li>System efficiency</li> </ul>	<ul style="list-style-type: none"> <li>Excess tool management</li> </ul>
<b>Risk Guidelines</b>	<ul style="list-style-type: none"> <li>Low risk tolerance</li> </ul>	<ul style="list-style-type: none"> <li>Accelerate rate of change/implementation.</li> </ul>	<ul style="list-style-type: none"> <li>Rapid change implementation</li> <li>Increase flexibility to reduce costs</li> </ul>

Exhibit 7  
FSM Computing Spending Summary

Manufacturing Computing Spending				% Chg. From 2002 Baseline	
\$M	2002	2003	2003 Rev.	2003	2003 Rev.
<b>Manufacturing Computing</b>	\$ 117.0	\$ 127.0	\$ 105.6	9%	-10%
200mm factories	\$ 96.7	\$ 92.2	\$ 72.0	-5%	-26%
300mm factories	\$ 20.3	\$ 34.8	\$ 33.6	71%	65%
<b>Central Engineering</b>	\$ 19.4	\$ 19.0	\$ 19.1	-2%	-1%
200mm support	\$ 5.4	\$ 1.9	\$ 1.9	-65%	-64%
300mm support	\$ 14.0	\$ 17.1	\$ 17.2	22%	23%
<b>CE with Security</b>	\$ 4.2	\$ 8.1	\$ 8.0	92%	91%
<b>CE/MC Software Licences</b>	\$ 21.6	\$ 29.2	\$ 27.6	35%	28%
<b>IT Allocation</b>	\$ 104.3	\$ 89.3	\$ 84.0	-14%	-19%
200mm factories	\$ 91.5	\$ 70.8	\$ 66.4	-23%	-27%
300mm factories	\$ 12.8	\$ 18.5	\$ 17.5	45%	38%
<b>Total</b>	<b>\$ 266.4</b>	<b>\$ 272.6</b>	<b>\$ 244.3</b>	<b>2%</b>	<b>-8%</b>
Total 200mm	\$ 193.6	\$ 164.9	\$ 140.4	-15%	-27%
Total 300mm	\$ 47.1	\$ 70.4	\$ 68.3	50%	45%
CAS TMG Security/SW	\$ 25.8	\$ 37.2	\$ 35.6	44%	38%

Note: Numbers not based on actual Intel data

Exhibit 8  
FSM Computing Headcount Summary

Manufacturing Computing Headcount						% Chg. From 2002 Baseline			
HC	2002	2003	2003 Rev.	Est. 2004	Est. 2005				
						2003	Rev.	Est. 2004	Est. 2005
<b>Manufacturing Computing</b>	<b>858</b>	<b>821</b>	<b>698</b>	<b>621</b>	<b>599</b>	-4%	-19%	-28%	-30%
MC 200mm factories	656	594	480	427	395	-10%	-27%	-35%	-40%
MC 300mm factories	202	227	218	194	205	13%	8%	-4%	2%
<b>Central Engineering</b>	<b>199</b>	<b>180</b>	<b>180</b>	<b>180</b>	<b>177</b>	-10%	-10%	-9%	-11%
CE 200mm support	55	18	18	18	15	-67%	-67%	-67%	-73%
CE 300mm support	144	162	162	162	162	13%	13%	13%	13%
<b>CE Info Security</b>	<b>19</b>	<b>32</b>	<b>32</b>	<b>32</b>	<b>32</b>	69%	69%	69%	69%
<b>Total</b>	<b>1,076</b>	<b>1,033</b>	<b>910</b>	<b>834</b>	<b>809</b>	<b>-4%</b>	<b>-12%</b>	<b>-23%</b>	<b>-25%</b>
Total 200mm	712	612	498	446	410	-14%	-30%	-37%	-42%
Total 300mm	346	389	380	356	367	13%	10%	3%	6%
CE Security/SW	19	32	32	32	32	69%	69%	69%	69%

Note: Numbers not based on actual Intel data

### Exhibit 9 FSM Computing Headcount 3-Year Trend

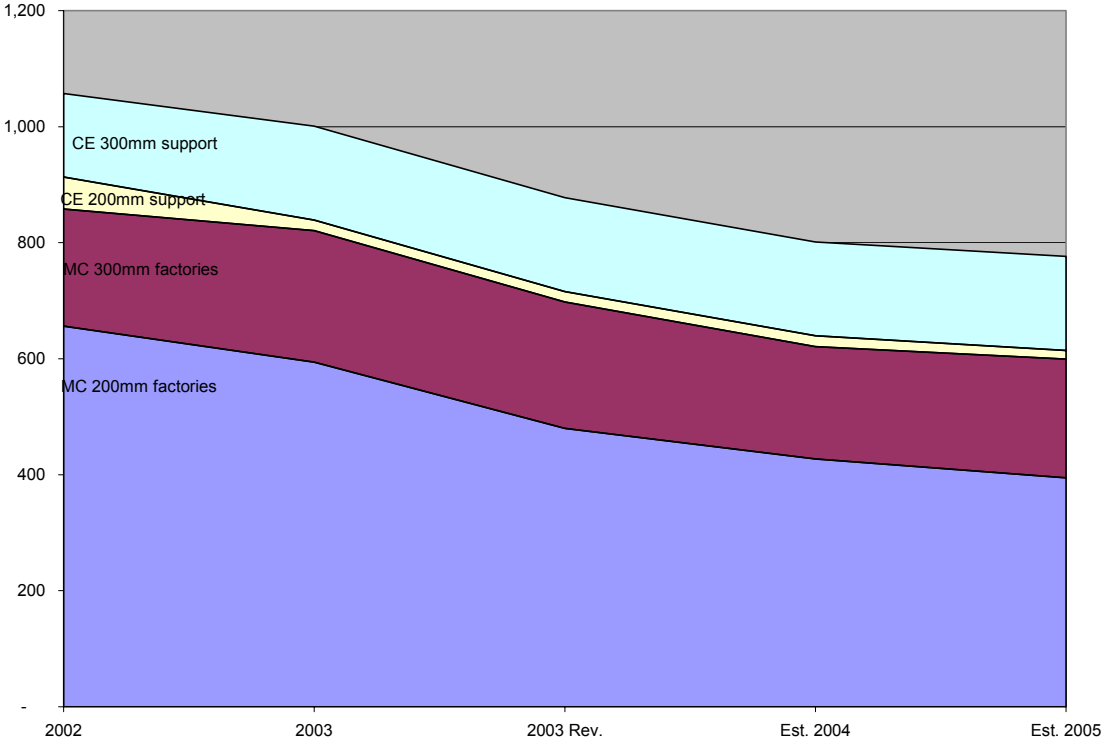

### Exhibit 10 Manufacturing Computing Cost Analysis

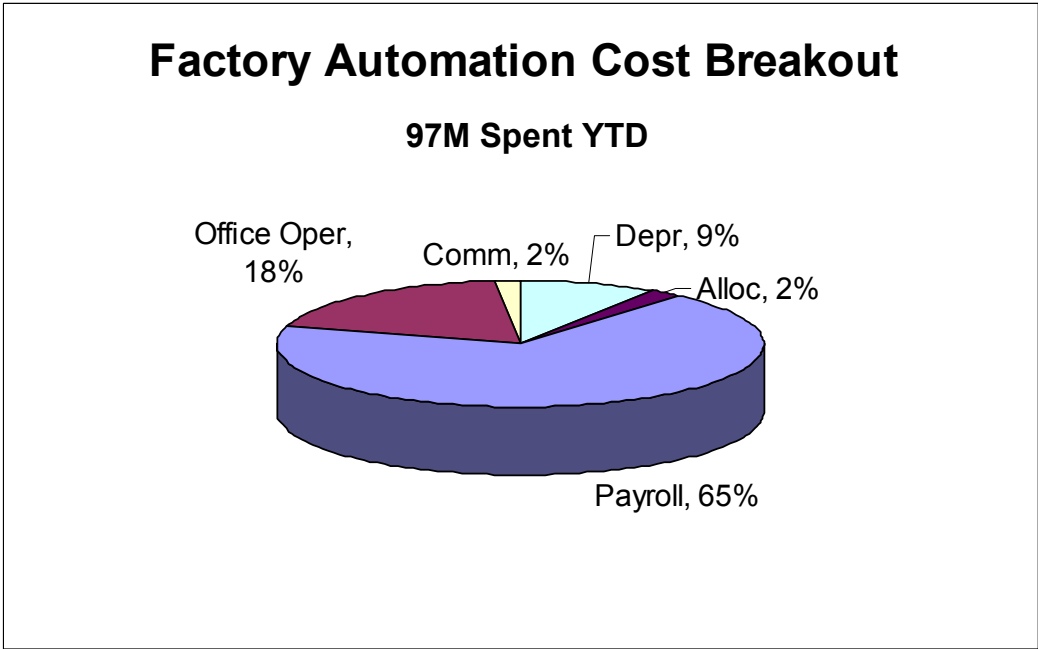

## Exhibit 11 Intel Manufacturing Computing Environment

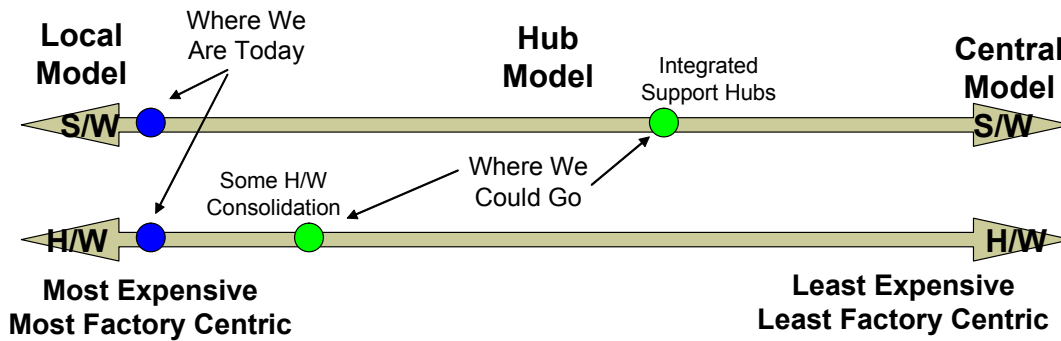

## Exhibit 12 Factory Automation Domain Task Analysis\*

Domain	Current H/C	Local %	Remote %	Local H/C	Remote H/C	Total	Delta from Current	Percent Decrease
Apps/Reports	133	14%	86%	7	94	101	32	24%
Database Admin	106	12%	88%	6	74	80	26	25%
Station Controller Dev	14	0%	100%	0	14	14	0	0%
Infrastructure	128	17%	83%	16	74	90	38	30%
AMHS Apps	56	40%	60%	23	14	37	19	34%
AMHS H/W	37	43%	58%	17	11	28	9	24%
AMHS CWW	187	100%	0%	156	0	156	31	17%
Station Controller Apps Modeling	72	78%	22%	45	27	72	0	0%
<b>Total</b>	<b>805</b>	<b>39%</b>	<b>61%</b>	<b>310</b>	<b>340</b>	<b>650</b>	<b>155</b>	<b>19%</b>

\*Note: Numbers not based on actual Intel data. Terminology: Station Controllers are the computer systems that allow the IT systems to interface directly with the production tools; Infrastructure represents hardware support; AMHS stands for Automated Material Handling Systems, which delivers the product from tool to tool without being touched by humans; Modeling is a group responsible for the configuration of the WIP systems. They are special skilled analysts that configure the IT systems.

## Exhibit 13 Centralized Organizational Structure

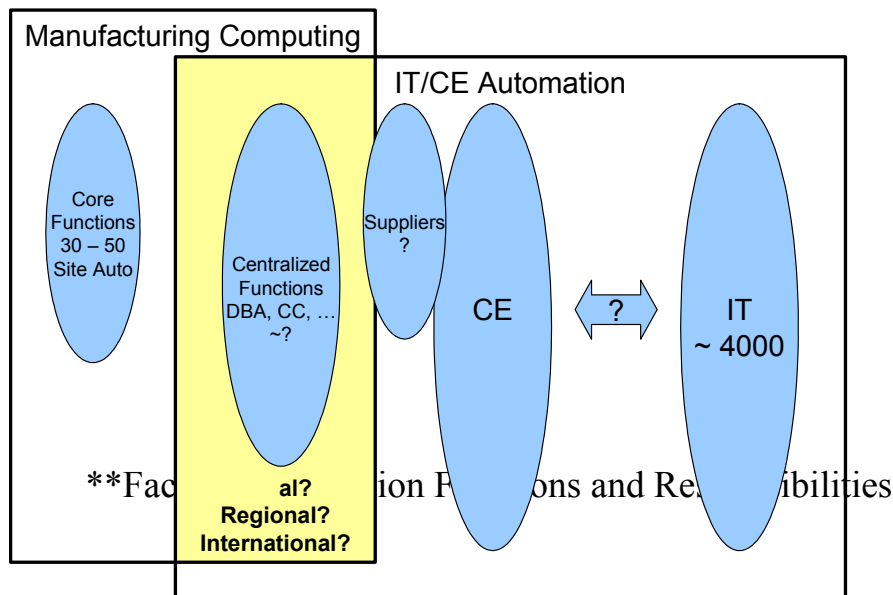

**Exhibit 14**  
**Large Factory Automation Headcount Case Study: Local Optimization\*\***

Function	Current HC	Optimized HC	Service Level Agreement Changes/Risks
Staff	5	3	1 Manager, 1 admin, 1 Staff Technologist
Decision Support (DSS)	7	3	Reports and Engineering tools only, no Group Leader, no development work, no on call, reports to MES
Infrastructure	15	12	Group Leader, retain on call, merge IT and Sort in, network for site
Database/Integration	4	3	Increase workload, share SQL with DSS, no GL, reports to Infrastructure
Help Desk	15	12	3 techs/shift, move HC to manufacturing for supervision, possibly to combine with AMHS sustaining?
Manufacturing Execution Systems (MES)	23	20	Group Leader, reduce modelers (add to ENG/MPC), add AMHS/Sort/DSS HC
Material Handling (AMHS)	11	7	Reduce AMHS to mech only, GL, 3 mech engrs, 3 intrabay. Applications to MES
IT Server	3	0	Merged into Infrastructure
IT Network	7	0	Merges into Infrastructure, supports site
Sort	10	0	No GL, merge into MES, apps support only
<b>Total</b>	<b>100</b>	<b>60</b>	<b>36% reduction</b>

\*\* - see next page

**Exhibit 15**  
**New Factory Automation Headcount Case Study: Local Optimization\*\***

Function	Current HC	Optimized HC	SLA changes / Risks
Staff	8	4	Minimal staff, MGR, Admin, 2 Staff Techs
Decision Support (DSS)	11	8	Group Leader (GL) plus reductions in all areas
Infrastructure	11	9	IT does all nets, GL plus 8 admins
Database/Middleware	5	5	DB only, no GL, under Infrastructure. MW to MES
Help Desk	15	12	3 Technicians/shift reporting to Manufacturing
Manufacturing Execution Systems (MES)	26	12	GL plus 3 MW plus 5 applications. No development, no installations. Merge 4 Sort.
Automated Material Handling (AMHS)	16	18	GL plus 2 mechanical engineers and 15 IB/NTSC/Modelers
IT	0	0	Covered as a site organization
Sort	8	0	Merges into MES
	<b>100</b>	<b>68</b>	<b>32%</b>

\*\* - see next page

**\*\* - Factory Automation Functions and Responsibilities**

Function	Responsibilities
Staff	Senior Managers or system support experts in each department.
Decision Support (DSS)	Group owns application development for engineer requests. Primary responsibility is specialized manufacturing reports used to track yields and WIP movement.
Infrastructure	Hardware support group. Owns, upgrades, and maintains systems.
Database/Integration	Database system management including upgrades, installs and maintenance. Also, own “middleware” applications that allow Intel Manufacturing IT systems to communicate.
Help Desk	First line of defense for factory IT issues. The help desk supports all IT arenas, and will follow documented procedures to isolate issues, and fix where possible. Issues not immediately fixable are escalated to the other group that can best resolve the issue.
Manufacturing Execution Systems (MES)	Install, Configuration, and Upgrades, and Maintenance of Factory Automation applications. Additional responsibility on making engineer requested updates to application configurations.
Material Handling (AMHS)	Owns Install, Maintenance, and Upgrade of material handling system that enables point-to-point delivery of wafers between tools.
IT Server	Owns physical install, maintenance, upgrades, and monitoring of all Server systems.
IT Network	Owns physical and IT install, upgrade, and monitoring of network systems
Sort	Owns automation systems for the Sort manufacturing organization

Exhibit 16  
Factory Automation Hub Model

Virtual Hubs distributed across MC but managed by Local Automation Departments

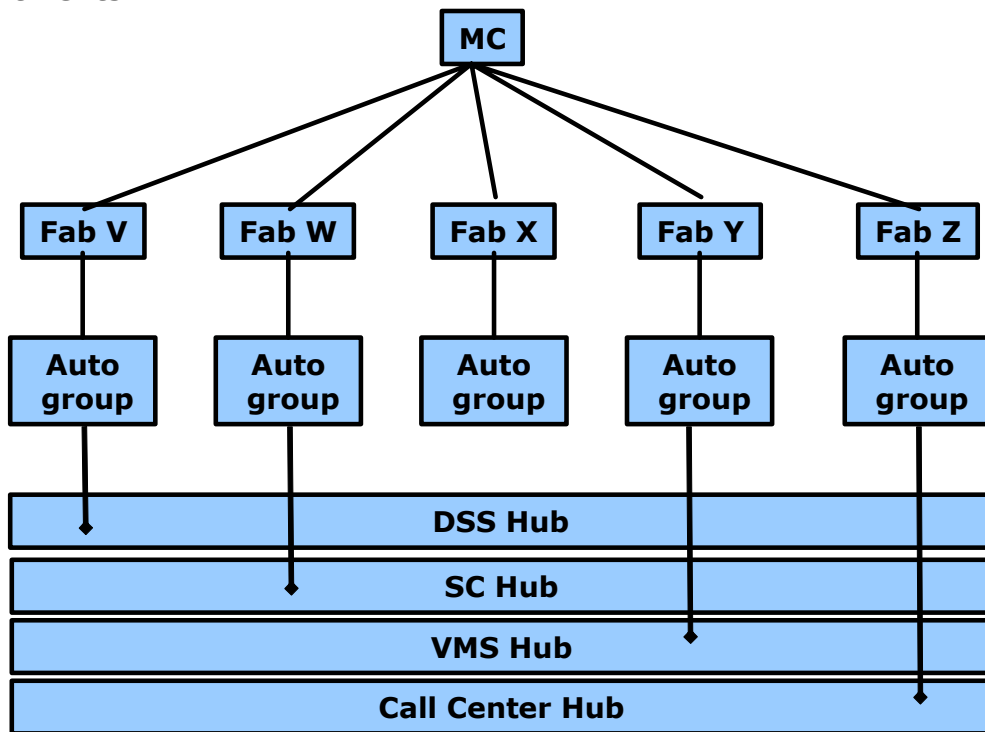

Exhibit 17  
Factory Automation Hub Model

- Virtual hubs with central management
- Local hub h/c decreases over time, integrated hub h/c increases

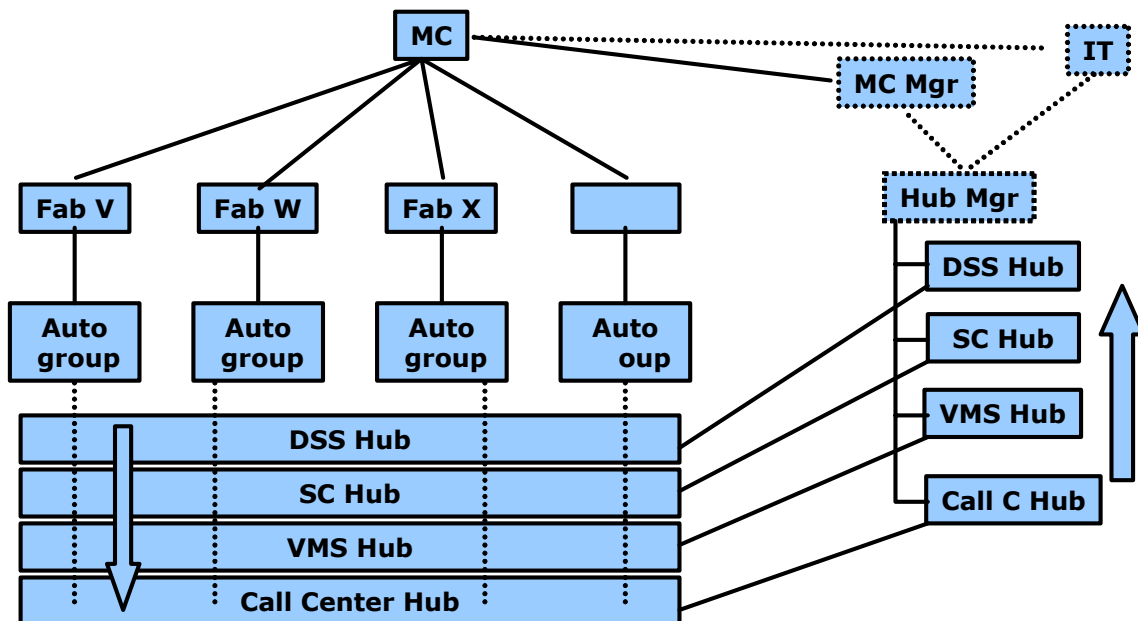
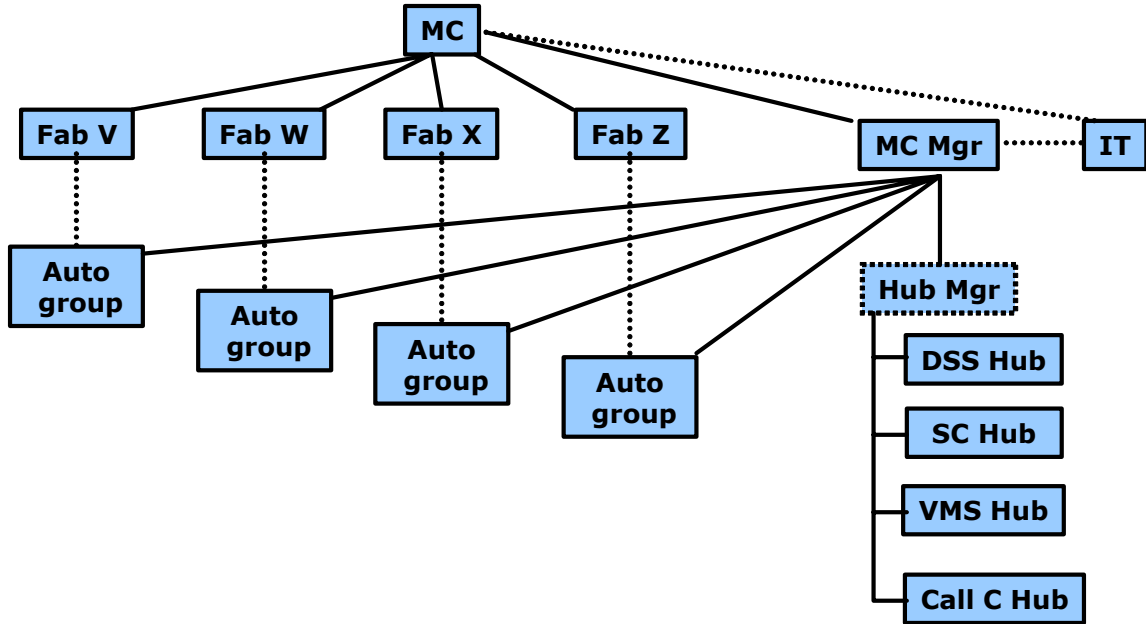



Exhibit 18  
Factory Automation Hub Model

- Automation reports solid line to MC automation manager, dotted line to factory managers. MC auto mgr works 2-box with IT manager.



# Appendix

## Relevant News Articles on Intel's Current and Future Business Prospects

K.C. Swanson

## Chipmakers Can Expect Less Bang for Their Bucks

By [K.C. Swanson](#)

Staff Reporter

12/31/2002 07:11 AM EST

URL: <http://www.thestreet.com/tech/kcswanson/10057972.html>

Next year will put to the test a key strategy for chipmakers: Invest as much as possible in technology during the downturn in order to become that much more profitable when semiconductor demand picks up.

The problem is that the recovery for semiconductors next year is expected to produce growth of only about 10% -- a pretty middling rebound. Big, rich chipmakers such as **Intel** (INTC:Nasdaq - news - commentary), **Texas Instruments** (TXN:NYSE - news - commentary) and **IBM** (IBM:NYSE - news - commentary) probably won't see the returns they would have expected a couple years ago when they started investing billions in state-of-the-art chip fabrication plants.

To be sure, leading semiconductor outfits may not have a choice about whether to invest, assuming they want to gain an edge in the long term. But the takeaway for investors isn't a cheery one: Chipmakers must spend tremendous amounts of capital to stay competitive, and as a result, offer increasingly humdrum growth prospects. That combination is bound to depress profitability amid a recovery -- and probably in the longer term as well.

A look at one measure of profits, return on capital, underscores the trend. A study of 15 chipmakers shows that returns fell to a 10-year low, at an average of 1.59%, in the third quarter, according to a recent report from Banc of America. That compares with an average of 17% annually over the past seven years.

Or consider Intel. In the fat days it boasted a return on capital as high as 30%, but as of the September quarter, its ROC was a mere 6.6%.

Granted, those numbers will improve when demand for chips picks up again. But analyst Mark FitzGerald still expects future returns for chipmakers in general to fall well below the historical averages, to the 10% range.

"In the '90s, it paid to be aggressive in investing when the market for PCs was high growth. PCs had 15% to 20% unit growth through most of the '90s. But now single-digit growth rates don't justify the same aggressive level of capital spending," he says.

### Costs Grow but Returns Shrink

Consider the two parts of the equation: a diminishing growth outlook and the spiraling cost of new chip fabrication plants.

Just last month, the leading trade group acknowledged there's been a long-term shift towards a lower growth rate for semiconductors, given the saturation of markets from PCs to autos.

Going forward, the industry should grow at only 8% to 10% annually, the Semiconductor Industry Association said, well below the historical rate of around 16% or 17%.

At the same time growth is flagging, manufacturing expenses have shot up dramatically as technology has grown more complex. A recent Merrill Lynch report noted that Moore's Law (the number of transistors that can be placed on a chip doubles roughly every 18 months) has a practical corollary: The minimum cost of an economically viable fab doubles every three years.

But semiconductor revenue certainly isn't growing at the same pace.

With the cost of a cutting-edge factory estimated at \$1.5 billion to \$2 billion, all but a handful of chipmakers are being priced out of the manufacturing business. The rest are going "fabless," meaning they outsource the actual production of semiconductors to so-called foundries.

Meanwhile, a few select chipmakers have plowed ahead with investments in new fabs that can process 300-millimeter-sized wafers, which produce 2.4 times more chips than the more common 200-millimeter wafers. Semiconductor companies are also continuing to shrink the size of transistor linewidths to a mere 90 nanometers, a move that not only reduces costs but also enables more functions to be integrated on a piece of silicon.

IBM's leading-edge 300-millimeter fab in East Fishkill, N.Y., which started pilot production in August, will ramp up into volume production throughout 2003. Texas Instruments' Dallas fab, now at 5,700 wafers per month, will produce up to 10,000 a month by the end of 2002. Both companies plan to begin producing on 90 nanometer linewidths next year.

Intel has positioned itself at the forefront of the shift to larger 300-millimeter wafers. With two 300 mm fabs now in production, Intel will have another up and running by the close of next year. By the end of 2003, up to half of all Intel's processors may be produced at 90 nanometers, estimates UBS Warburg.

Yet with Intel's capital spending expected to reach \$4.7 billion this year, equal to 18% of expected revenue, some analysts maintain the chipmaker is investing too heavily -- even though capex has dropped from 27% of sales in 2001. A ratio of 10% to 15% is a healthier ratio for chipmakers, given slowing growth rates, says Banc of America's FitzGerald.

"They can't afford it because the end markets aren't growing enough," he says. "If they throw more money at it and the end markets are seeing slowing growth, they're just digging a bigger hole for themselves."

Intel CFO Andy Bryant declined to comment on its future spending strategy, citing the quiet period leading up to the company's January earnings release.

Yet in light of the so-so demand environment and expensive manufacturing assets, some think Intel will find it tough to maintain its return on invested capital. "That's the main reason behind our sell recommendation on the stock," says Merrill Lynch analyst Joseph Osha.

Even so, wealthy Intel is much better equipped to deal with pressure than smaller fry that manufacture their own semiconductors. "We've said stocks like LSI Logic and Atmel are going to get squeezed from both directions," says Osha.

Unlike smaller companies, he adds, Intel could justify its strategy over the longer term, because it can afford to make big investments and because the resulting improvements in manufacturing will enable it to distance itself further from competitors. "If I were Intel, I'd do the same thing," says Osha. "If I were huge and rich, I'd probably use my biggest asset, which is being big and rich."

Indeed, some investors cast the aggressive-investing approach as the sensible, competitive response in a notoriously tough industry. "The ones taking the risk are the ones who are not spending," contends Graham Tanaka, head of Tanaka Capital Management and an Intel investor. "Look what happened to the Japanese [DRAM-makers] in the late '80s and early '90s. They stopped spending, and the Koreans took their business," he says. "Intel is doing the right thing" by investing heavily.

Take the transition from 200-millimeter to 300-millimeter wafers. "They allow you to pack on over two times as many chips per wafer, so your cost per chip is actually declining, even though the [initial] cost is higher," points out Tanaka. "You're getting much more chip production per line." That will be a boon to Intel's business when the economy accelerates, he says.

Meanwhile, smaller linewidths allow chipmakers to differentiate their processors, muscling out rivals. Intel reckons that at 90 nanometers it can crank out its next two processors at clock speeds of roughly double the 3 gigahertz of the Pentium 4.

Intel and other chipmakers that stay in the manufacturing game over the next few years should eventually face better prospects, even if profitability doesn't return to '90s levels. "The return on invested capital for guys who survive is going to improve," says Susan Crossley, an analyst at Wells Fargo. "If you play out all these doomsday scenarios about slowing growth rates and consolidation, what you end up with is a scenario a few years from now where there are a few real big winners."

But don't expect the interim to be painless. "I think next year will serve as a test," says Osha. "2003 doesn't look like a sharp recovery. But it will take a few years to shake out."

---

## Report: Global Chip Sales Grow at Snail's Pace

Lisa Gill, [www.EcommerceTimes.com](http://www.EcommerceTimes.com)

The Semiconductor Industry Association (SIA), a trade group that counts Intel ([Nasdaq: INTC - news](#)) and AMD ([NYSE: AMD - news](#)) among its members, has announced that global sales of semiconductors increased just 1.9 percent to US\$12.51 billion in November compared with October levels. The slow growth rate, which bucks the usual holiday spending trend, signals that the semiconductor industry is still struggling to overcome its worst-ever slump in 2001.

Indeed, though somewhat lackluster, the latest sales total represents a 19.6 percent increase from November 2001 sales of \$10.6 billion.

### Holiday Sales Provide Little Cheer

Sluggish consumer holiday spending is partially to blame for slow November growth, according to the SIA. Such spending typically lifts fourth-quarter electronics and semiconductor sales.

"Holiday sales this year were below expectations," World Semiconductor Trade Statistics Americas vice chairman Bill Jewell told the E-Commerce Times. "I don't think we'll see even the normal seasonality we see in the fourth quarter and December."

### Wireless Benefits All

Still, there are some positive signs. SIA president George Scalise said sales of wireless chips continue to drive upward momentum. "The November sales of the global chip industry underscores the healthy recovery that has been building momentum throughout this year," he noted.

Indeed, worldwide chip sales have seen a steady, slow climb this year as the industry digs out of last year's pit. October chip sales grew 1.8 percent to US\$12.5 billion compared with September of this year.

Sales of flash memory and digital signal processors, both used in mobile phones, also benefited from healthy wireless chip sales, with increases of 6.6 percent and 3.7 percent, respectively, in November.

In addition, the SIA pointed to a .5 percent increase in microprocessor sales and 5.8 percent growth in DRAM revenue as a sign that the PC sector is gaining momentum.

### Recovery on Horizon

A semiconductor recovery is still anticipated for 2003, said Jewell, who estimated that growth could range between 15 and 20 percent worldwide, primarily in the wireless, flash and digital signal processor sectors.

"Overall, 2 percent month-over-month is good, and the book-to-bill ratio for November was looking better than it has been in a bit," Aberdeen Group chief research officer Peter Kastner told the E-Commerce Times. "It's still a single data point, and Aberdeen's view is that there is no sign of a global semiconductor turnaround yet."

But Kastner said he remains hopeful for the second half of 2003, noting that much of the anticipated recovery will depend on global economic and political forces, including the possibility that the United States may fight a war.

### **Sales in America Slow**

Semiconductor sales in the Americas declined .8 percent in November to \$2.63 billion, while sales in Japan decreased .6 percent to \$2.83 billion.

The SIA noted that the strongest areas are Europe, which saw a 5.8 percent jump to \$2.6 billion, and Asia-Pacific, which recorded a 1.3 percent increase to \$4.62 billion.

Since last year, sales in the United States and Canada have been slow, with just a 5 percent increase recorded in the period. At the same time, the Asia-Pacific region has seen 33.5 percent growth, Japan 21.9 percent and Europe 12.2 percent.

## The Digital Dilemma

George Gilder, [Gilder Technology Report](#), 12.18.02, 4:56 PM ET

NEW YORK - Why are we bringing up a generation of kids who don't know physics but know everything about Windows? Why are there entire nations, such as India, whose economies are increasingly devoted to this and other totemistic excesses of software? Why has software become the medium through which we deal with the physical world?

We fly airplanes with software; our bombs hunt our enemies with software; we run switches with software whose annual upgrades are the single-largest operating cost in running a network. Across the global economy, we ritualistically do in software functions that could be far better accomplished with applications-specific hardware, the all-optical network is perhaps the supreme example.

[Sign up for Forbes' Free Investment Guru Weekly e-mail.](#)

The science of application-specific hardware has atrophied in part because every young information scientist is taught that the physical layer doesn't matter to the universal computer. But since the challenges the world gives us are messy, the decision to use a generalized machine to solve them necessarily entails a parallel and ponderous effort to represent the specificity of the world in the machine's terms--the software. Software is proverbially the bottleneck of the information economy--because under the Turing model that's where all the work is done.

And what work it is to represent to that universal computer all the problems of the world, natural and man-made alike, using a language that itself moves ever farther away from any physical primitive, rising above machine language to assembly language to ordinary programming language and thence to the hyper-programming language. Each level, no matter how great and complex the tasks it addresses, masks complexities that must ultimately be resolved on the chip by exploiting the tremendous processing clock-rates to accomplish hugely complex procedures.

The digital crisis is so pervasive we have begun to assume it as part of the background. Six-hundred-thousand bugs in Windows XP from **Microsoft** (nasdaq: [MSFT - news - people](#) ) is a crisis. Winnowing them down to two-hundred-thousand bugs is a crisis that has gone chronic, to be coped with rather than resolved. Windows Home XP has some paradoxical bugs that can't be eliminated without transforming the program. Mega-software has reached some kind of wall, one manifestation of the crisis.

Another manifestation can be seen in Pentium as it moves up toward 60 gigahertz, which **Intel** (nasdaq: [INTC - news - people](#) ) now proposes as a feasible goal. Power increases linearly with clock-rate and exponentially with voltage. Voltage has declined to the point where it generates leakage faster than it relieves power consumption. So there is a real question of whether we can continue to increase the clock-rates that mega-software increasingly demands.

### Sacrificing Efficiencies

As hierarchical design, the very process that shielded us from the growing complexities on the surface of the chip, ascends multiple levels of abstraction it becomes impossible to test all the resulting designs in all their possible combinations. So you must incorporate built-in self-test, devoting more and more of the processor to testing itself, and even then you don't test it adequately.

The tests become increasingly tests of interfaces. Since those cannot be fully assured as the chip gets bigger and bigger, you include a lot of redundant cells. The structures for incorporating the redundant cells become themselves increasingly complex. As this process advances, the device becomes increasingly suboptimal. At some point it becomes inferior to using a set of separate chips of a manageable size and modularity--reversing the essential teleology of the integrated circuit. But that doesn't solve the problem; it merely shifts the complications and conflicts to the bus.



At current speeds and densities, the universal clock doesn't work anymore, so you have to have separate clock pulses all across the chip, sacrificing many of the fundamental efficiencies of the digital system. Asynchronous designs are a partial and valuable solution. But in isolation every one of these problems can appear solvable. Taken together they entail a set of fundamentally irresolvable conflicts that suggests the whole digital endeavor is reaching an impasse. The clock problem, the power problem, the leakage problem, the interface problem, the pad-limited problem, the failure of memory technology to keep apace with processor clock-rates, so that most of the clock cycles are wait-states. All these together represent a technology in climacteric.

### **Moore's Law In Crisis**

My colleagues, Dynamic Silicon editors Nick Treddenick and Brion Shimamoto, have been wandering around the office with graphs showing not that Moore's Law is reaching the end of its run, but that its continuation may be irrelevant. They point out that the last four generations of chip geometries, 0.25 microns, 0.18 Microns, 0.13 microns, and now 0.09 microns (90 nanometers) account for only 20% of chips made by the major foundries such as TSMC. The adoption curves for the next cycle of Moore's Law used to be nearly vertical--as soon as we could squeeze more circuits on a chip, everybody wanted the capacity. Today the adoption curves for new technologies are nearly horizontal, even though theoretically the marginal cost to make a 90-nanometer function on a 300-millimeter wafer is less than 20% of the cost of a 130-nanometer chip made on a 200-millimeter wafer.

We spent quite a bit of time in the office recently trying to explain this through the Clayton Christensen overshoot theory (the personal computer already over-serves its real market), through mismatch theory (memories cannot keep up with the processor cycle times), and design complexity (design tools have once again fallen behind the complexities of single-chip electronics). In any case, it seems that the bounty of Moore's Law, which for so long appeared to drive the information industry, is increasingly shunned. Whatever the explanation, the phenomenon tends to confirm the existence of a crisis of digitization.

*Excerpted from the November 2002 edition of Gilder Technology Report.*

DECEMBER 13, 2002

NEWS ANALYSIS: TECHNOLOGY

## The Big Boys' Mad Dash into Wi-Fi

**The wireless Internet is all the rage. The question now: Can tech giants turn it into a bona fide, billable business?**

It started just three years ago, when techies began programming their laptops with a new wireless standard and jerry-rigging antennas to their broadband Internet connections. Poof! Suddenly, they could move around in their homes or offices, even into the backyard, and stay connected to the Net.

Now, this technology, known as wireless fidelity, or Wi-Fi, is taking off. Vast, informal networks are sprouting up. Zippy Wi-Fi connections, each one with a range of some 300 feet, now blanket entire neighborhoods from New York to Stockholm to Hong Kong. Some 2 million mobile surfers in North America already use Wi-Fi, and Gartner Inc. expects the number to double by next year. The surge in demand has prompted the Federal Communications Commission to find ways to set aside more spectrum for Wi-Fi.

Wi-Fi is all the rage, and finally, the struggling tech industry is gearing up to cash in on it. In the next year, Dell Computer Inc. ([DELL](#)) will begin equipping practically all of its laptops with Wi-Fi connections. Sony Corp. ([SNE](#)) is putting it into a host of electronic gadgets. Intel Corp. ([INTC](#)), which is investing \$150 million in Wi-Fi startups, plans to release new chips with Wi-Fi receivers by spring.

And on Dec. 5, AT&T ([T](#)), Intel, and IBM ([IBM](#)) launched a new company called Cometa Networks. Its goal is to bundle thousands of Wi-Fi connections, called hot spots, into one nationwide network -- and to convert this grass-roots phenomenon into a bona fide, billable business.

**GENERATION GAP.** How will it work? Phone or cable companies will either buy access from a wholesaler such as Cometa or stitch together a network themselves. Then they'll likely offer subscribers national or regional Wi-Fi service for an extra \$10 or \$15 a month. In this new business, which analysts expect to take shape in consumer and corporate markets within a year, a subscriber in San Francisco will be able to take the laptop or PDA to Detroit or Atlanta, knowing that it links up wirelessly to the Net in airports, hotels, and probably even ballparks. "My feeling is that Wi-Fi starts to become pretty prevalent during the second half of next year," says Christopher Fine, an analyst at Goldman, Sachs & Co.

But the path to Wi-Fi riches is strewn with obstacles. Lots of users already have Wi-Fi hookups in their homes but will resist an extra charge to take the Net on the road. And before Wi-Fi conquers the corporate world, the industry must come up with strong security software. Last May, retailer Best Buy Co. ([BBY](#)) temporarily shut down its wireless network after a security analyst in a parking lot managed to intercept data, including credit-card numbers,

from the company's wireless cash registers. Best Buy soon plugged the gap and turned the network back on. Analysts predict that software protections will be sturdy enough for the broad corporate market by next year.

Wireless phone companies are facing perhaps the biggest challenge of all. The industry is gearing up for a multi-billion-dollar rollout of high-speed wireless networks known as Third Generation, or 3G. Soon, Wi-Fi may offer many of the same mobile services. True, it works only in stationary hot spots, and not, say, in a moving car. But it's far cheaper. Cometa, for example, is hoping to pull together its Wi-Fi network for a mere \$30 million -- chicken feed by 3G standards. The danger is that customers will log onto the mobile Internet through Wi-Fi and blow off 3G.

**LURING USERS OUTSIDE.** For now, phone companies have little choice but to race into Wi-Fi. T-Mobile USA Inc., which has already set up hot spots in 2,000 Starbucks Corp. ([SBUX](#)) cafes, is spending \$100 million to build a nationwide Wi-Fi network. The goal: to hook users on Wi-Fi, then to push them toward 3G. "It's going to be difficult for anyone to make a business case just serving Wi-Fi," says John W. Stanton, chairman of T-Mobile USA. "It's a piece of the puzzle."

It's by far the hottest piece of the mobile Internet. With the price for home networks dropping below \$200, hardware sales are expected to grow from about \$1.5 billion to \$2.3 billion this year, according to Synergy Research Inc. The trick now is to lure all these home networkers outside, onto the broader Wi-Fi networks -- and bill them for it. It's the tech sector's next big step toward mastering the mobile Internet.

---

By Heather Green in New York, with Ben Elgin in San Mateo, Calif.



Reuters

## China throws weight behind homegrown computer chip

Monday December 23, 6:08 am ET

BEIJING, Dec 23 (Reuters) - Chinese government officials and private firms joined hands on Monday to promote a homegrown computer chip in their push for a domestic information technology industry that is less reliant on foreign companies.

Unveiled in September, the "Dragon" central processing unit boasts speeds between 200 and 260 megahertz, roughly equivalent to models global chip leader Intel Corp (NasdaqNM:[INTC](#) - [News](#)) first marketed between 1995 and 1997.

The Chinese chip is likely to be used in applications requiring less speed than the fastest chips now available.

Officials from the Chinese Academy of Sciences (CAS), the Ministry of Information Industry, electronics giant Haier Group, Linux developers Red Flag Software Co Ltd and server provider Dawning Corp Ltd all pledged support for the chip at a news conference.

Li Guo Jie, director of the Institute of Computing Technology under CAS, said he expected the chip to meet the needs of a niche market despite its limitations.

"People won't buy the chip just because it's home-made," he told a news conference. "It must be competitive and fit market needs."

He said the chip would soon reside in personal computers, mobile phones and televisions, with a target production of one million units in 2003.

The Chinese Academy of Sciences said about 10,000 chips had already been produced this year.

Technology analysts have said the domestic CPU is supposed to reduce China's dependence on Intel and other chipmakers such as Advanced Micro Devices Inc (NYSE:[AMD](#) - [News](#)) for both financial and security reasons.

China wants to install its own chips in sensitive military devices to retain better control, they say. (Reporting by Juliana Liu, editing by Sonali Desai; Reuters Messaging: [juliana.liu.reuters.com@reuters.net](mailto:juliana.liu.reuters.com@reuters.net); email: [juliana.liu@reuters.com](mailto:juliana.liu@reuters.com); +8610 6586-5566 x213)

Reuters

## Cheap chips everywhere seen driving next tech wave

Tuesday January 7, 9:44 pm ET

PEBBLE BEACH, Calif., Jan 7 (Reuters) - A coming wave of consumer devices featuring ultra-cheap and powerful microprocessors embedded in almost everything will drive the next decade of innovation in computing technology, a leading trend-spotter said on Tuesday.

Paul Saffo, the director of the Menlo Park, California-based Institute for the Future, said the shift to pervasive computing, in which chips are stitched into the fabric of ordinary life, would define technology in the coming years just as the personal computer had in the 1980s and the Internet did in the 1990s.

"We're in the middle of a 10-year shift," Saffo said in address at the Semiconductor Equipment and Materials International Industry Strategy Symposium in the posh golf resort of Pebble Beach. "Every 10 years a new technology comes along" that drives demand."

Embedded processor technologies that will lead to new applications include cheap sensors, such as those used in global positioning systems and video cameras, as well as radio frequency identification tags, Saffo said.

Proponents of such RFID tags, which store, send and receive data through weak radio signals, believe they will one day replace bar codes and revolutionize the way that merchandise and product inventories are tracked once their price falls far enough.

In a major commercial breakthrough for the technology, the Gillette Co. (NYSE:[G](#) - [News](#)) said on Monday that it would begin the first large-scale test of RFID technology pioneered by the Massachusetts Institute of Technology.

The RFID tags, which could send store managers automatic alerts when stocks of razors run low, will be manufactured by Morgan Hill, California-based Alien Technology Corp.

"Philip Morris wants to put one in every cigarette carton sold," Saffo said. "RFID is what will replace the bar code."

The biology and health industries will be particularly hot areas for such technologies, he said. For instance, companies are already working on handheld pocket-sized X-ray devices for use by emergency personnel, while consumer cardiac monitors are already being used by athletes at home and on the road.

"The impact of the information technology revolution will be dwarfed by what's happening in biology," Saffo predicted.

The emergence of small, embedded processors is also contributing to a shift away from products and toward higher-margin services, he said. For example, cell phone providers practically give the handsets away and make most of their money on the service they offer.

"The next industry to fall will be the automotive business," Saffo said.

For example, the Mercedes C Class sedan has 153 microprocessors and features an optional satellite-based communication system which enables drivers to contact car companies to get map and other driving information, stock updates and help in emergencies.

"It's not a car, it's a computer," Saffo said. Soon, "they'll be selling cars at or below cost" because they will be able to make up the difference with service fees.

## Glut check: Overcapacity is making recovery more difficult

By William Neikirk  
Chicago Tribune

**DURHAM, N.C.** - It's called overcapacity:

- The world's auto industry can now produce 20 million more cars than consumers can buy.
- Will Daland, a 55-year-old computer programmer, worked for some of the world's premier telecommunications companies before that overbuilt industry hit a slump two years ago and he was laid off. Now, Daland says, he may start driving a truck if he can't find a job in his field.
- Cisco Systems built six new buildings to expand its presence at the high-tech Research Triangle Park in North Carolina when the dot-com business was sizzling. All six buildings now are empty.

Each of these instances reflects a powerful wave sweeping the economy -- overcapacity.

In the factory and in the office, it has a more concrete dimension: Businesses can produce far more than we need. Supply has simply outstripped demand. When that happens, production slows, equipment sits idle, costs go up, workers are laid off, and investments are postponed.

The capacity glut exists on a scale that this country and many others haven't seen for decades, and it at least partially explains why it is so difficult for the American economy to shake off a recession that by all measures seemed mild.

U.S. companies overbuilt in the 1990s, believing that the good times would never end. But the ``bubble" popped with the turn of a new century and with the economy tipping into recession in March 2001 and then stumbling more after the Sept. 11 terrorist attacks.

As a result, the human toll of what economists call a ``jobless recovery" is still mounting. The national unemployment rate, only 3.9 percent in September 2000, hit 6 percent in November, and many analysts doubt it will fall in the foreseeable future. Since September 2000, 3 million jobs were lost, almost 2 million of them in manufacturing.

In Silicon Valley, the unemployment rate in September 2000 was 1.7 percent, a record low. It has soared to 7.8 percent in November.

And despite 12 interest rate reductions by the Federal Reserve since January 2001 -- and President Bush's \$1.3 trillion tax cut -- the economy is limping along. And there are concerns about deflation, or falling prices, which the country hasn't seen since the Great Depression.

A look at various industries around the country -- airline, auto, machine tool, steel, textile, high-tech -- suggests that working off excess capacity in factories and creating more jobs won't be as easy as it was in the past. Indeed, business leaders appear to be thinking differently about how and when they might add jobs as the economy improves, with some questioning whether they will add them in the United States at all.

### **Better productivity**

#### **• Fewer are needed for new technology**

Joel Goldberg, vice president for operations at Chicago's Atlas Material Testing Technology, said his firm doesn't plan to hire new workers. New technology it has installed in recent years has boosted the company's productivity by 5 percent to 10 percent a year, he said, and ``the reality is, we need fewer and fewer people."

At the same time, U.S. companies are rapidly expanding their operations to low-wage countries such as China and India. There, Goldberg said, ``People have become a commodity, so to speak, and you go where the supply is."

Now, U.S. technology is increasingly a commodity too. The glut in manufacturing capacity extends to products that once were at the cutting edge but have turned into mere commodities in an amazingly short time. Cellular phones, televisions, computers and many other electronic goods can now be made so cheaply around the globe that companies are forced to cut prices to sell them.

The nation's own efficient system of production has contributed to the excess of supply over demand, said Wallace Hopp, a professor of industrial engineering and management sciences at Northwestern University.

Consumers are benefiting from lower prices, enabling them to stretch their dollars, but that comes at a cost that could hurt the economy in the long run. Because businesses are able to make more than customers can buy, they aren't doing much investing in plants and equipment, and they are shaving workers to become more efficient.

The problem has spilled over to many other areas of the economy not directly related to manufacturing. Vacancy rates of commercial space are rising across the country -- nowhere more sharply than Silicon Valley. Hotel rooms added in the '90s are hard to fill.

According to David Rizzo, president and chief executive of MCNC, a research and consulting firm in Durham, it may be five years before all the high-speed fiber-optic cable laid by the telecommunications industry is used. Today, that cable is an enormous investment that sits mostly idle with the fading of the dot-com boom.

Further, the expansion of the wireless revolution, such as the use of more cell phones for Internet connections, may even make some of this investment obsolete, some analysts say.

No one is sure how difficult it will be to work off the glut in capacity through economic growth. But one thing is clear: Businesses have idled more of their capacity in the past two years than they have in a long time. The Federal Reserve said manufacturers are using only 73.5 percent of capacity, well below the average of 80.9 percent in 1967-2001. Even during the 1990-91 recession, factories used nearly 77 percent of capacity to produce goods.

``There needs to be consolidation in some of these industries," said Paul Kasriel, an economist at Chicago's Northern Trust. ``That's one of the ways you take capacity out. Either firms go out of business, they merge or they mothball. And that's what needs to happen."

Nowhere is the glut of supply more vivid than in the desert, where more than 800 airliners, including many jumbo jets designed for transcontinental flight, sit parked in long rows. The planes have been grounded by the downturn that marked the end of the 1990s boom and also by the reduction in flights caused by the Sept. 11 attacks.

``Some of them will never fly again," said Aaron Gellman, a professor and transportation expert at Northwestern University.

During the giddy 1990s, many airlines went on a buying spree as the economy boomed and the demand for flights appeared to be expanding rapidly. Competition with domestic and foreign carriers fueled the race to build more airliners and fly more flights, and no one seemed overly concerned that a big problem was brewing.

Now the problem is clear, and the victims are increasing. Like several other airlines before it, United -- the country's second-largest -- filed for bankruptcy after a federal board refused to approve a loan guarantee.

## **Airlines hurt**

### **● Severe competition from overcapacity**

Jim Corridore, airline analyst for Standard & Poor's, said that despite the cutbacks, ``There still is airline overcapacity. It has led to destructive competition in the industry where fares are now at five-year lows."

The problem is equally daunting in the U.S. automobile industry, which also is struggling with labor costs. Foreign manufacturers are planning to build more plants in the United States to take market share away from the Big Three.

Currently, the automobile industry in North America has an excess capacity of about 2 million vehicles, said Sean McAlinden, director of economics at the Center for Automotive Research in Ann Arbor, Mich., and that gap is growing. For every two plants in the United States being closed, three are being built by foreign manufacturers, he said.

Led by General Motors, Detroit dealt with the immediate glut in supply this year by offering zero percent financing to spur sales, in effect offering a steep price cut to keep its factories going. GM's reason: It had to pay its workers under the United Auto Workers contract whether they were working or not.

But the capacity problem will come to a head this year when the auto companies and the UAW negotiate a new contract. McAlinden and other analysts predict that more Big Three plants, perhaps as many as seven, will have to be shuttered to reduce overcapacity.

In textiles and steel, the United States has suffered from chronic overcapacity for decades as global competitors have sprung up. As a result, the United States has erected protective tariffs and established import quotas. Both industries are severely challenged by global competition.

When will it end?

No one is sure when or how the global glut in production capacity will work itself out. To economist Stephen Roach of Morgan Stanley, soaking up all this worldwide surplus would require ``three years of aggressive economic growth" in a global economy now rising anemically -- only about 2.5 percent a year.



JANUARY 27, 2003

STREET WISE

By Olga Kharif

## Intel: Better Than Meets the Eye

**The Street winced at capital-spending cuts. But lower costs and new plants may make it a star, especially if chip sales beat estimates**

CEO Craig Barrett clocks hundreds of thousands of airborne miles directing the affairs of Intel ([INTC](#)), the world's largest chipmaker, but he's always careful to keep its feet squarely on the ground. Witness the latest earnings announcement on Jan. 14. While fourth-quarter revenues of \$7.2 billion were up 10% sequentially, Barrett nevertheless sounded a cautionary note, announcing that Intel will slash capital spending in 2003 by up to 26%. Wall Street took the announcement as a red flag.

Investors, however, may want to look a little closer. Barrett's push to keep expectations down to earth could yield pleasant surprises, if unit sales exceed analysts' expectations.

Since those capital-spending cuts were deeper than expected, Intel's stock dropped from just shy of \$18 on the day of Barrett's announcement to \$15.85 as Jan. 24's close. The news appeared to be fresh evidence that a recovery in PC sales, which drive 80% of Intel's revenues, will be weaker than had been expected. Shares of semiconductor-equipment makers also tumbled.

**BLAZING FINISH?** Don't forget, however, that many analysts have long predicted slow growth in demand for chips in 2003 -- and that Intel must cut costs rather than ramp up capacity. In that light, Barrett's moves look like a sound strategic decision. Standard & Poor's recently upgraded the stock from avoid to hold, based on fourth-quarter performance and the capital-spending cuts.

Lower costs -- more than a recovery in demand -- could make Intel's financials shine later this year. Let's look at the fourth quarter, which ended Dec. 31. Intel sold 34 million processors, surpassing its previous quarterly record of 33 million units in 2000, estimates Jonathan Joseph, an analyst with Salomon Smith Barney. Yet it generated \$1 billion less in profits than in its record quarter of 2000.

That's because processor prices have fallen. And Intel's overall costs have increased as a percentage of revenue, partly because it has invested in new chipmaking plants, or fabs. As a result, gross margins now stand at 51.6%, vs. 62.9% two years ago.

**THREE OPTIONS.** Intel has three ways Intel to restore margins, Joseph figures: The first would be a jump of 25% to 30% in unit sales. Second, prices on processors might rise by the same amount. Third, costs could shrink.

Option No. 1 looks problematical. Chip sales should increase by only 9% this year, according to Salomon Smith Barney. Option No. 2 appears no more likely, since Intel's processor prices have fallen 30% from a high of \$235 in 1996, estimates Joseph, who sees that trend

continuing.

He has a point: Processor speed, which had been accelerating by between 60% to 70% annually, will increase by only 11% in 2003, Joseph believes, and a typical PC buyer goes for lower price, not faster performance. Plus, Intel's main rival, AMD ([AMD](#)), will unveil several new chips this spring, which could further pressure Intel to pare prices further.

**READY TO MOVE.** That leaves the third option. While Intel has decided to cut capital spending this year, it's actually at the tail end of a three-year increase in capacity. A new fab in Rio Rancho, N.M., that became operational in October should increase overall capacity by 15% this year, estimates George Burns, president of chip-development consultancy Strategic Marketing Associates. If, as expected, demand recovers in 2004, this extra capacity will come in handy. When operating at full tilt, the new plant will offer 30% cost savings over older fabs.

Intel has already built most of its new plants, so it should hold off on equipping them until demand picks up, says Marc FitzGerald, an analyst with Banc of America Securities. Small wonder Intel will spend only \$3.5 billion to \$3.9 billion on capital improvements this year, vs. \$4.7 billion in 2002. Until demand picks up, Intel will save up to \$1.2 billion over last year -- a substantial sum for a company that booked \$26.8 billion in revenue in 2002.

Intel spokesperson Chuck Malloy says the chipmaker's new plants are on schedule. "When the economic upturn comes," he says, "we'll be in a position to ramp up very, very quickly."

**BARGAINING POWER.** Additionally, Intel should be able to leverage capital spending further in 2003. Semiconductor gearmakers are desperate for sales, taking a further 10% off the cost of already discounted machines, estimates Fred Wolf, an analyst with investment firm Adams, Harkness & Hill. On some equipment, Intel's sheer size and buying power mean even better deals are likely. Last year, according to S&P, it accounted for nearly 20% of the money spent on semiconductor equipment.

In the past month, Intel closed an older plant in Oregon that made flash memory chips more expensively than its newer plants. Evaluations of the building are under way to see if it can be used for a newer manufacturing process, says Malloy. And as of early January, 2003, Intel quietly exited its ASIC (application specific integrated circuit) custom-chip business. Analysts think the operation was attracting too few customers to justify the outlay. Intel has already stopped accepting new orders, though it will complete the design projects it had already started, says Intel spokesperson Erica Fields.

Intel expects margins to remain steady, at 51%. Most portfolio managers are waiting for substantial increases in demand -- and bottom-line boosts -- before picking up Intel again. Howard Sutton of the \$300 million Tera Capital Global Fund, is shorting the stock. He believes it will drop to the low- to mid-teens and says more cuts may be needed before values begin to rise again.

**LOW-BALL ESTIMATE?** It likely will be years, if ever, before Intel revisits the sort of stellar financial performance that marked 2000. But with \$1 billion in profits in its latest quarter, it remains squarely in the black. Plus, it has \$10.8 billion in cash and short-term investments on

hand.

Barrett seems to be counting on Salomon Smith Barney's projections for chip demand in 2003 being too low. And any further rises in unit sales later in the year will be gravy on an improving financial picture. All told, if it catches just a few breaks, Intel could provide investors with a fairly pleasant surprise.