

XIII. PHYSICAL ACOUSTICS*

Prof. U. Ingard
Prof. R. D. Fay
D. Avison
L. W. Dean III

P. Gottlieb
G. C. Maling, Jr.
E. J. Martens, Jr.
M. B. Moffett

G. W. Myers
J. B. Schaefer
P. M. Scop
H. L. Willke, Jr.

A. NONLINEAR DISTORTION OF SOUND WAVES IN LIQUID HELIUM

The speed of propagation of a disturbance in a fluid depends to some extent upon the "strength" of the disturbance. The reason for this nonlinear effect is twofold. First, the speed of the disturbance at a point is the sum of the local speed of sound and the particle velocity at that point and, second, the local speed of sound depends on the pressure and temperature at that point. Although these nonlinear effects are small, they are cumulative, so that after a wave travels a certain distance they will be of considerable importance, producing, for example, repeated shocks.

Therefore, an initially "monochromatic" sound wave will continuously feed energy into higher frequencies, which leads to a (nondissipative) attenuation of the fundamental frequency wave component. The present study of nonlinear distortion of waves in liquid helium was initially undertaken as a problem of separating the dissipative from the non-dissipative attenuation of the fundamental wave, as indicated in Quarterly Progress Report No. 53, page 170. In addition, it appears possible that a study of some of the nonlinear wave characteristics will prove useful in the determination of certain basic properties of the liquid itself.

In this report some initial experimental results are presented. The experimental arrangement is shown in Fig. XIII-1. In this first experiment, multiple reflections of 1-mc wave pulses were observed. The receiver crystal, tuned to 2 mc, was followed by a filter so that the second-harmonic content of the wave pulse could be studied as a function of the distance of wave travel. Actually, the sensitivity of the receiver crystal was sufficiently high at other frequencies so that the behavior of higher harmonics than the second could also be studied. Photographs were taken of the oscillographic display of the second-harmonic pulses for a wide range of wave amplitudes associated with driving voltages of the transmitted crystal ranging from 4 to 200 volts rms. Representative pictures, taken at 2.5° K, are shown in Fig. XIII-2. Notice how the second harmonic grows with time, that is, with the distance traveled, until a maximum is reached, after which the pulse decays. Notice also how the travel distance that is required to produce maximum second harmonic decreases with increasing wave amplitude. Examination of a number of

* This research was supported in part by the U. S. Navy (Office of Naval Research) under Contract Nonr-1841(42). Reproduction in whole or in part is permitted for any purpose of the United States Government.

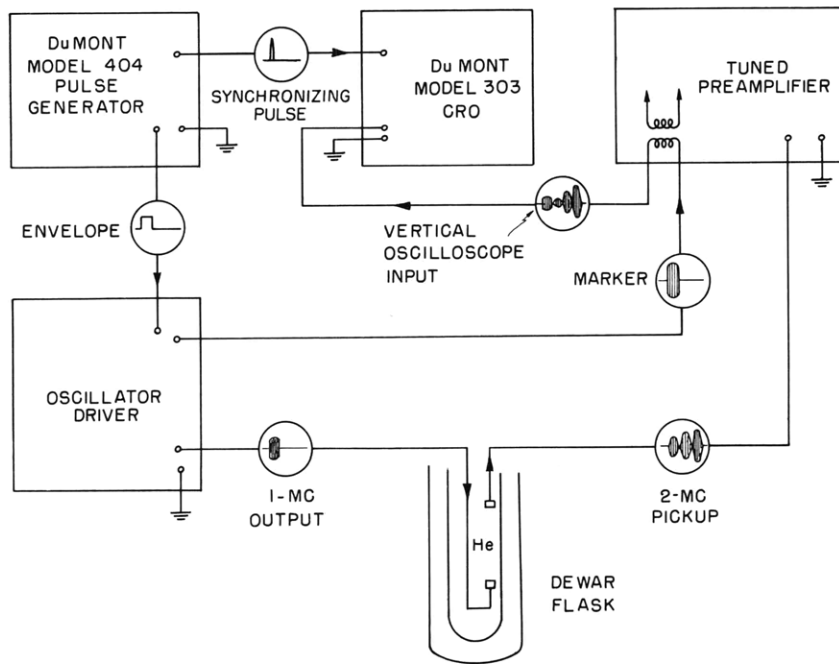

Fig. XIII-1. Block diagram of experimental arrangement.

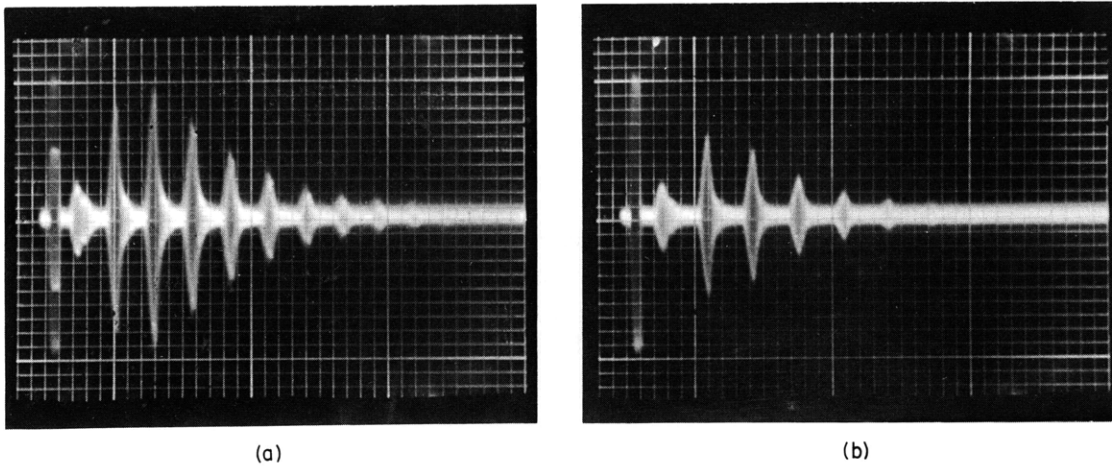

Fig. XIII-2. Wave pulse amplitude of second harmonic as a function of time: (a) $T = 2.5^{\circ} \text{ K}$, driving voltage = 9.4 volts; (b) $T = 2.16^{\circ} \text{ K}$, driving voltage = 23.5 volts.

(XIII. PHYSICAL ACOUSTICS)

photographs of this kind have shown that

(a) For low and moderate source strengths, the position of maximum intensity of the second harmonic moves toward the source crystal as the -0.1 power of the source strength.

(b) For higher source strengths, the envelope maximum varies as a much larger negative power of the source strength, and approaches the -1 power for voltages higher than 200 volts rms.

(c) The spatial rate of growth of the wave, before the maximum is reached, is very nearly linearly proportional to the energy in the fundamental mode and is independent of distance from the source.

We wish to make the following comments about the theory of the nonlinear distortion. If we imagine ourselves on a coordinate system moving with the wave, then v can be written as

$$v = \frac{1}{2} \sum_{-\infty}^{\infty} v_k \exp[(k2\pi i/\lambda) x]$$

where $v_k = v_{-k}^*$, and $|v_k|$ is a function of time only. Then $\overline{v^2}$ (average over space) $= \sum |v_k|^2$. We now consider the vector $\vec{y} = (v_1^2, v_2^2, \dots, v_j^2, \dots)$ and assume that there exists a matrix A , with the property that $d\vec{y}/dt = A\vec{y}$ and $A = D + K$, where D is diagonal and K antisymmetric. The matrix D defines the direct loss of energy by each mode caused by viscosity, and k gives the net loss of each mode as a result of coupling. We expect that the energy lost, for example, by v_j^2 to v_i^2 , is equal to that gained by v_i^2 from v_j^2 , so that for small motion ($Re < 1$) we can consider k constant and anti-symmetric. Assuming that A can be diagonalized, we can put the solution in the form

$$v_j^2 = \sum_k F_k(\lambda_1 \dots \lambda_j \dots) C_k e^{-\lambda_k t}$$

where C_k can be adjusted to satisfy boundary conditions. Considering just the first two modes and initial conditions, we obtain

$$v_1^2 = \frac{U^2}{1-a} e^{-\lambda_1 t} \left[1 - a^2 e^{-(\lambda_2 - \lambda_1)t} \right]$$

$$v_2^2 = \frac{U^2 a e^{-\lambda_1 t}}{1-a} \left[1 - e^{-(\lambda_2 - \lambda_1)t} \right]$$

where U is the initial amplitude of a sinusoidal wave, and $\lambda_1/\lambda_2 = (1+4a^2)/(a^2+4)$. The factors λ_1 and λ_2 can be evaluated in terms of constants of the medium in the equations of motion, but this has not been done yet.

H. L. Willke, Jr., G. W. Myers, U. Ingard

B. ACOUSTIC ATTENUATION IN THE VICINITY OF AN ORDER-DISORDER
TRANSITION IN A COPPER-GOLD ALLOY (Cu_3Au)

There are a number of bimetallic alloys that exhibit an order-disorder transition. This is a transition from an orderly arrangement of atoms in the crystal lattice to a disorderly arrangement in the same lattice. There is a critical temperature below which disorder increases rapidly with temperature and above which disorder is complete. The transition is accompanied by marked changes in certain physical properties of the alloy, such as the resistivity and specific heat. Investigation has shown that there is also a sudden change in the absorption of sound waves in the vicinity of the critical temperature of the alloy Cu_3Au .

The experimental arrangement is shown in Fig. XIII-3. The pulse generator delivers 600-kc rf pulses to crystal No. 1 where they are converted to sound. The sound passes through the sample and two glass buffer rods. It is then received by crystal No. 2, amplified, and displayed on the oscilloscope.

The physical length of the pulse is shorter than either glass rod, but considerably longer than the sample. The first received signal, therefore, is a superposition of reflections in the sample, and the measurement is not a simple transmission measurement. However, if the frequency is varied until all reflections arrive in phase, it can be shown that the height of the received signal, S , is $S = e^{-\beta L} T^2 / (1 - R^2 e^{-2\beta L})$, where R and T are the reflection and transmission coefficients of the glass-sample interface, L is the length of the sample, and β is the attenuation of sound in nepers per unit length. R and T can be found from the build-up rate of the received signal, and β can be calculated.

The results, which include a correction for absorption by the glass rods, are shown in Fig. XIII-4 as a function of temperature. Specific heat and resistivity measurements as a function of temperature (1) are given in Fig. XIII-5.

Qualitatively, we can say that the increase in resistivity depends on the increase in disorder, as they both increase smoothly to a certain value at the critical temperature and remain there. The specific heat, as would be expected, depends on the rate of change of disorder, because it returns to its normal value after the transition. Sound attenuation seems to depend on both because there is a large residual attenuation beyond T_c and a large peak just below T_c where the rate of change of disorder is most rapid.

Quantitatively, the attenuation in nepers per centimeter increases by a factor approximately 10^4 times that at room temperature.

Various observers have investigated the possible existence of an additional order-disorder transition in this alloy at 600°C . No change in sound attenuation was observed near this temperature. Because of the sensitivity of this

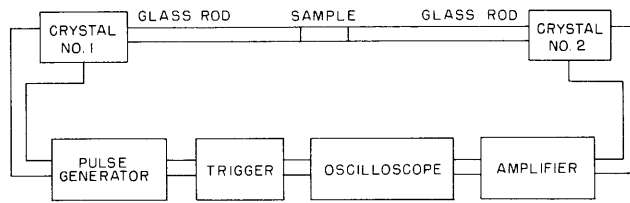

Fig. XIII-3. Diagram of sound attenuation apparatus.

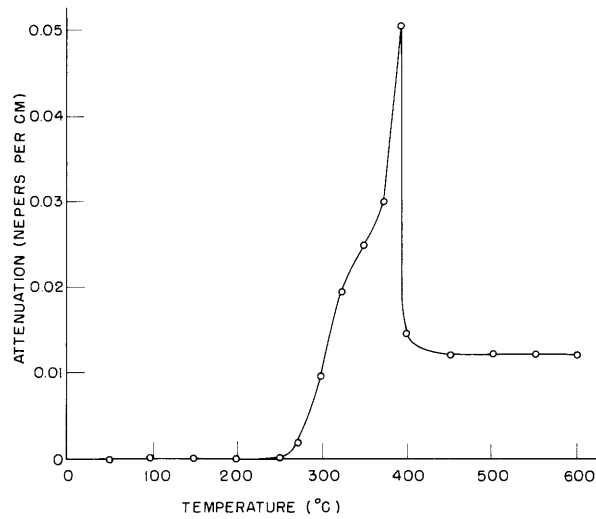

Fig. XIII-4. Sound absorption in Cu_3Au as a function of temperature.

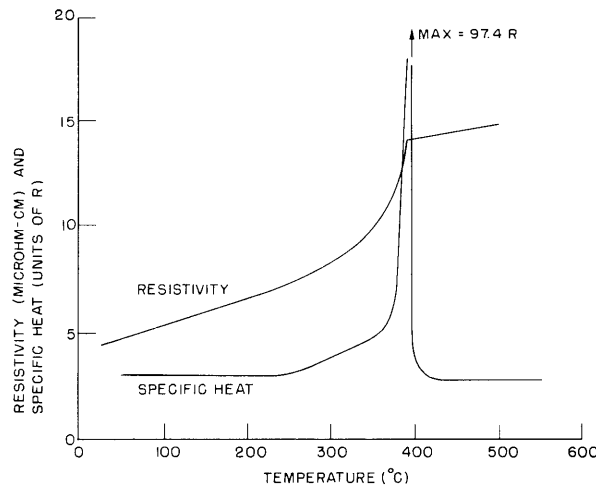

Fig. XIII-5. Resistivity and specific heat in Cu_3Au as a function of temperature.

method we might doubt the existence of this second transition.

P. M. Scop, L. W. Dean III

References

1. F. C. Nix and W. Shockley, Order-disorder transformations in alloys, *Revs. Modern Phys.* 10, 1 (1938).

C. ATTENUATION OF SOUND IN ALUMINUM

The vibration-measuring apparatus originally developed by Bordoni (1) and used by him at low temperatures (2) was modified for measuring the attenuation of sound in aluminum at room temperature. The effects of air damping and of holes were also explored. In the Bordoni apparatus, the extensional vibrations of a small metal rod cause a change in the capacitance between the rod and a nearby electrode. This capacitance is used in the tank circuit of a high-frequency oscillator, so that changes in the capacitance will modulate the frequency of the oscillator. The frequency-modulated signal is then detected, the resulting output being linearly proportional to the motion of the end of the bar.

The original detector was replaced by a ratio-detector circuit, which offers better linearity, less noise, and higher output. The attenuation of aluminum was measured in two ways with this apparatus. First, the rod was driven at its fundamental resonant frequency, the excitation was turned off, and the decay of the vibration was recorded graphically. Second, the amplitude of the vibration as a function of frequency was plotted, and a resonance curve drawn. Both of these methods gave the same value for the attenuation within 10 per cent. A quality factor, Q , was defined in the usual way, and the value of Q for aluminum at room temperature was found to be 3.6×10^4 .

We found that the resonant frequency could be located with great accuracy. The resonant frequency becomes lower with increasing temperature. Thus, if the sample is slightly heated and the driving frequency set slightly above resonance, the sample can be allowed to cool through resonance. A continuous resonance curve then can be drawn by the recorder. This curve can be calibrated by plotting points as a function of frequency, and the resonant peak can be located with an accuracy better than one part in 10^5 .

The effect of air damping was noted by allowing air to leak slowly into the system and observing the effect on the Q . The results show that air damping is very small until a pressure equal to approximately 0.001 mm Hg is reached. At this pressure the air damping begins to reduce the Q . At approximately 0.1 mm Hg, when the Q has been reduced roughly one-half, further increases in pressure begin to have little effect on the Q . These data are illustrated in Fig. XIII-6.

(XIII. PHYSICAL ACOUSTICS)

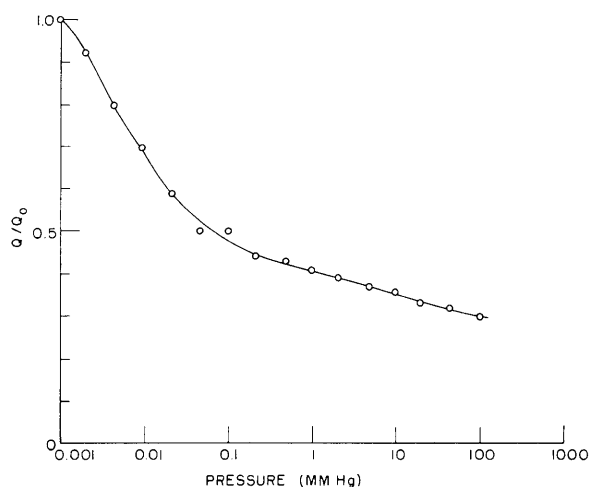

Fig. XIII-6. Quality factor as a function of pressure.

A hole was drilled in the center of the rod, and the Q was remeasured. A hole, whose diameter was 0.15 times the diameter of the rod, reduced the Q one-half. Enlarging the hole to 0.2 times the diameter of the rod reduced the Q to 1/20 of the original value. Smaller values than this could not be measured. The power dissipated by the larger hole is 19 times that dissipated by the smaller one. The power scattered from a cylinder (the holes are cylindrical) in the long wavelength limit varies as the fourth power of the cylinder radius.

Since the fourth power of the ratio of the two radii is only approximately 4, there must be some loss mechanism in addition to that of scattering of energy into other modes. The holes were drilled at the velocity-standing-wave node, a region of high stress. A hole drilled here allows strains to develop that would not be present with no hole, and the dissipation is increased.

Since the speed of sound in a metal depends directly on the elastic constants of the metal, and since the speed of sound in a rod can be determined by this method with an accuracy better than one part in 10^5 , the relationship between the elastic constants of a metal can be measured with great accuracy with this apparatus.

J. B. Schaefer, L. W. Dean III

References

1. P. G. Bordoni, *Nuovo cimento* 4, 177 (1947).
2. P. G. Bordoni, Elastic and anelastic behavior of some metals at very low temperatures, *J. Acoust. Soc. Am.* 26, 495-503 (1954).

D. SCATTERING OF SOUND BY SOUND

Equipment has been built for the simultaneous generation of square rf pulses at frequencies of 0.6 mc-1.0 mc that have durations continuously variable from approximately 40 μ sec to 200 μ sec. These pulses are converted to sound under water by means of quartz crystals that are cut for the appropriate frequencies. At present, the largest pulses that the equipment will transmit to the crystals have a peak-to-peak amplitude of 600 volts.

The sound pulses are made to collide at right angles, and the sum frequency

component of the scattered wave is searched for by means of a quartz crystal cut for 1.6 mc. The experiment has been performed several times, but no scattered wave has been observed. With the present equipment, a scattered wave whose amplitude is 60 db below the amplitudes of the incident waves could easily be detected. It may be possible to improve this factor 20 to 40 db by increasing the signal to the crystals and by additional filtering.

L. W. Dean III

E. SOUND SOURCE NEAR A VELOCITY DISCONTINUITY

This work is reported in detail in a thesis (1) in which the derivations are given; only a brief discussion of the results is presented here.

For many practical reasons, it is important to know the sound field that is produced

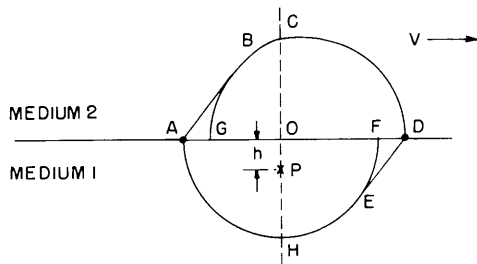

Fig. XIII-7. Sound surface and surfaces of constant phase.

by a source near a plane interface between two media in relative motion. Such a situation is shown in Fig. XIII-7, with the source at point P and the interface along \overline{AOD} . The formal solution for any source is found by expressing the source function as an integral over plane waves, and then using the plane-wave reflection and transmission coefficients to obtain the integrands for the reflected and transmitted fields. These formal integrals cannot be expressed in a closed

form in terms of elementary functions, but they can be evaluated asymptotically in order to give the far-field approximation to the reflected and transmitted waves in a closed form. This approximation is obtained by using a saddle-point evaluation of the exact formal integral solutions.

The contours of constant phase, shown in Fig. XIII-7, agree with what would be expected. The semicircle \overline{AHEF} represents the wave front of the direct wave from the source at P (h is assumed to be infinitesimally small). The curve \overline{GBCD} represents the direct wave in medium 2 when $h = 0$ (the source is at the interface). The distance \overline{GO} is shorter than \overline{AO} , and \overline{OD} is longer than \overline{OF} , as would be expected from the fact that the sound travels slower upstream and faster downstream in medium 2 (relative to medium 1 at rest). In order to have continuity of the wave front, the segments \overline{AB} and \overline{ED} must, therefore, be added. These straight wave fronts violate the causality principle because they arrive at the point of observation sooner than the curved direct wave front. Thus these straight wave fronts cannot carry energy to infinity. This fact is verified by calculation because the straight wave fronts are found to have a faster fall-off

(XIII. PHYSICAL ACOUSTICS)

with distance from the source than the curved wave fronts have.

If h is assumed to be small, but finite, then the transmitted wave is peaked at point B, and the amplitude goes to zero at G and D. The amplitude varies fairly smoothly over the rest of the wave front, except over the arc \overline{GB} which is reduced by an amount proportional to $e^{-h\lambda}$. The closed expression for this amplitude and graphs of this expression are given in the thesis (1).

P. Gottlieb

References

1. P. Gottlieb, Acoustics in moving media, Ph.D. Thesis, Department of Physics, M. I. T., May 18, 1959.