

OPERATIONS RESEARCH CENTER

working paper

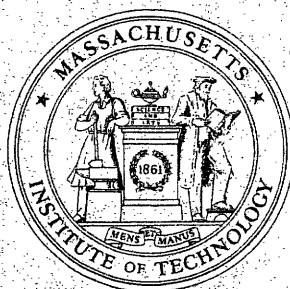

**MASSACHUSETTS INSTITUTE
OF TECHNOLOGY**

Acceleration Noise as a Measure of
Effectiveness in the Operation of Traffic
Control Systems*

by

Cady C. Chung and Nathan Gartner

OR 015-73

March 1973

Operations Research Center
Massachusetts Institute of Technology
Cambridge, Massachusetts 02139

Research supported by KLD Associates, Inc., in connection with
Department of Transportation Contract FH-11-7924.

ABSTRACT

Acceleration Noise measures the disutility associated with successive decelerations and accelerations in a signalized environment. It provides an indication of the smoothness of traffic flow. As such it constitutes a generalization of the number-of-stops concept and is suitable to replace it as an additive measure-of-effectiveness for designing and evaluating the operation of traffic control systems.

This report develops models for calculating the acceleration noise incurred by a platoon of vehicles travelling along a signal-controlled traffic link. Several flow patterns are analyzed: discrete arrivals, uniform-continuous arrivals and variable-continuous arrivals. A computer program and test results are described. The models can be easily extended for use in signal-controlled networks.

Table of Contents

	<u>Page</u>
1. Introduction and Definition of Acceleration Noise	1
2. Acceleration Noise of a Single Vehicle at a Signalized Intersection	3
3. Acceleration Noise with Shock Wave Assumptions	6
4. AN - Additional Assumptions	18
5. Computer Model and Program to Calculate Acceleration Noise for Continuous Flow Patterns	26
Appendix A: The Computer Program	33
Appendix B: Sample Results	36
References	37

1. INTRODUCTION AND DEFINITION OF ACCELERATION NOISE (AN)

Motorists on a transportation facility very often evaluate the facility by the speed at which they can travel and by the uniformity of the speed. Travelers in a vehicle will feel most comfortable if the vehicle is driven at a uniform speed. When the traffic on a highway is very light, a driver generally attempts, consciously or unconsciously, to maintain a rather uniform speed, but he never quite succeeds. He has to accelerate and decelerate occasionally instead. The distribution of his accelerations (deceleration is minus acceleration) essentially follows a normal distribution (see, e.g., Ref. 1).

From recent research results (1-5), the acceleration noise (AN) has proved to be a possible measurement for the smoothness or the quality of traffic flow. AN is defined as the standard deviation of the accelerations. It can be considered as the disturbance of the vehicle's speed from a uniform speed.

Mathematically, the standard deviation of a set of n numbers X_1, X_2, \dots, X_n is denoted by S and is defined as:

$$S = \left[\frac{1}{n} \sum_{i=1}^n (X_i - \bar{X})^2 \right]^{\frac{1}{2}}$$

where \bar{X} denotes the mean of the X 's.

If $a(t_i)$ denotes the acceleration of a vehicle at time t_i , the number of t 's or the total time period is equal to

2.

$$\sum_{i=0}^T t_i = T$$

and the average acceleration of the vehicle for a trip-time T is

$$a_{ave.} = \frac{1}{T} \int_0^T a(t_i) dt$$

Thus, mathematically, the acceleration noise σ can be written as:

$$\sigma = \left\{ \frac{1}{T} \int_0^T [a(t_i) - a_{ave.}]^2 dt \right\}^{1/2}$$

and
$$\sigma^2 = \frac{1}{T} \int_0^T [a(t_i) - a_{ave.}]^2 dt$$

It can be proved that

$$\sigma^2 = \frac{1}{T} \int_0^T [a(t_i)]^2 dt - (a_{ave.})^2$$

and since $a_{ave.}$ approaches zero for any prolonged journey, the AN is normally calculated by

$$\sigma^2 = \frac{1}{T} \int_0^T [a(t_i)]^2 dt$$

where T is modified to denote the running time only. The reason is that if a vehicle is stopped for some part of the journey, the AN (a time average) will

be arbitrarily smaller if T includes the entire period (1, 3, 4).

The accelerations of a vehicle can be measured directly by an accelerometer or approximated from a speed-time trajectory of the vehicle's trip (3 - 5).

AN measures the disutility associated with successive decelerations and accelerations in a signalized environment. As such it constitutes a generalization of the number-of-stops concept and is intended to replace it as an additive measure-of-effectiveness for signal-controlled traffic networks. It will be used primarily in conjunction with delay times (see Ref. (6 - 8)). The present report develops models for calculating the AN incurred by a platoon of vehicles traveling along a signalized traffic link. Several flow patterns are analyzed: discrete arrivals, uniform--continuous arrivals and variable--continuous arrivals. The models can be easily extended for use in networks.

2. ACCELERATION NOISE OF A SINGLE VEHICLE AT A SIGNALIZED INTERSECTION

Let us first consider a single vehicle arriving at a signalized intersection.

Let

c = cycle length (sec.)

g = effective green time (sec.)

r = effective red time (sec.)

$c = g + r$

If we denote the beginning of a red period by $t = -r$, the beginning of the following green period will be $t = 0$, and the end of this cycle will be $t = +g$.

Assuming that:

$$d = \text{deceleration rate (ft/sec.}^2\text{)}$$

$$a = \text{acceleration rate (ft/sec.}^2\text{)}$$

$$v_a = \text{normal driving speed (ft/sec.)}$$

We assume that the vehicle approaches the intersection at a constant speed v_a . If the signal aspect is red the vehicle decelerates at a constant rate d to a full stop. As the signal turns green, it accelerates to the driving speed v_a at a constant rate a .

Let

$$t_d = \text{deceleration time (sec.)}$$

$$t_a = \text{acceleration time (sec.)}$$

$$t_s = \text{stopped time (sec.)}$$

$$T = t_d + t_a$$

Referring to Fig. 2.1 we have

$$t_d = v_a/d$$

$$t_a = v_a/a$$

and the acceleration noise σ is:

$$\begin{aligned} \sigma &= \left\{ \frac{1}{T} \int_0^T [a(t)]^2 dt \right\}^{1/2} \\ &= \left\{ \frac{1}{t_d + t_a} [d^2 \cdot t_d + a^2 \cdot t_a] \right\}^{1/2} \end{aligned}$$

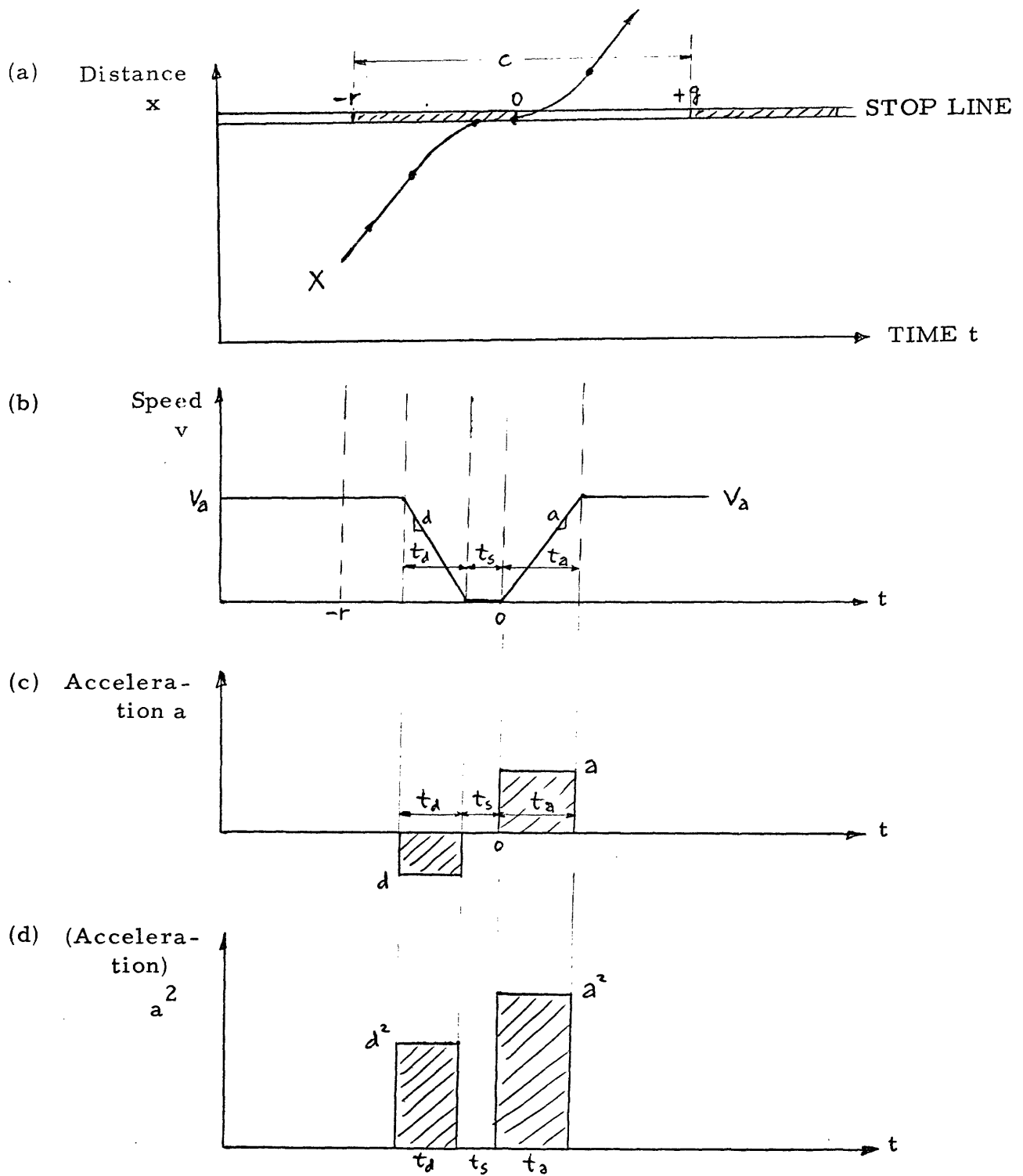

Fig. 2.1 - AN of a single vehicle at a signalized intersection; (a) vehicle trajectory; (b) speed variations; i.e., (d) deceleration-acceleration graphs

If we have a platoon of cars arriving at the intersection, some cars have to come to a full stop, others just slow down and speed up again. Fig. 2.2(a) shows the trajectories of a few cars arriving at an intersection. As car Y approaches the intersection, the signal is about to turn green, so Y slows down (assumed that the same deceleration rate d applies) to a slower speed V_b and accelerates back to its normal speed V_a (with the same acceleration rate a as before).

3. ACCELERATION NOISE WITH SHOCK WAVE ASSUMPTIONS

Based on Lighthill and Whitham's theory (9), when a platoon of cars is stopped at a signalized intersection, a shock wave (deceleration shock wave) starts traveling backwards (line AB in Fig. 3.1) at a speed C_d (slope of line AB). When the signal turns green, the vehicles start accelerating, and acceleration shock waves are formed and travel forward.

Let us assume that all vehicles come to an instantaneous stop as they enter line AB, and accelerate instantaneously to their normal speed at line OB. As long as there is a queue they depart at the saturation flow rate. Vehicles that arrive after time t_B pass through without stopping. In this simplified case the AN is directly proportional to the number of stops, because we only consider cars that stop at the intersection.

If we have a uniform arrival flow, and let

q_a = arrival flow rate (veh/sec.)

p = duration of the arriving platoon (sec.)

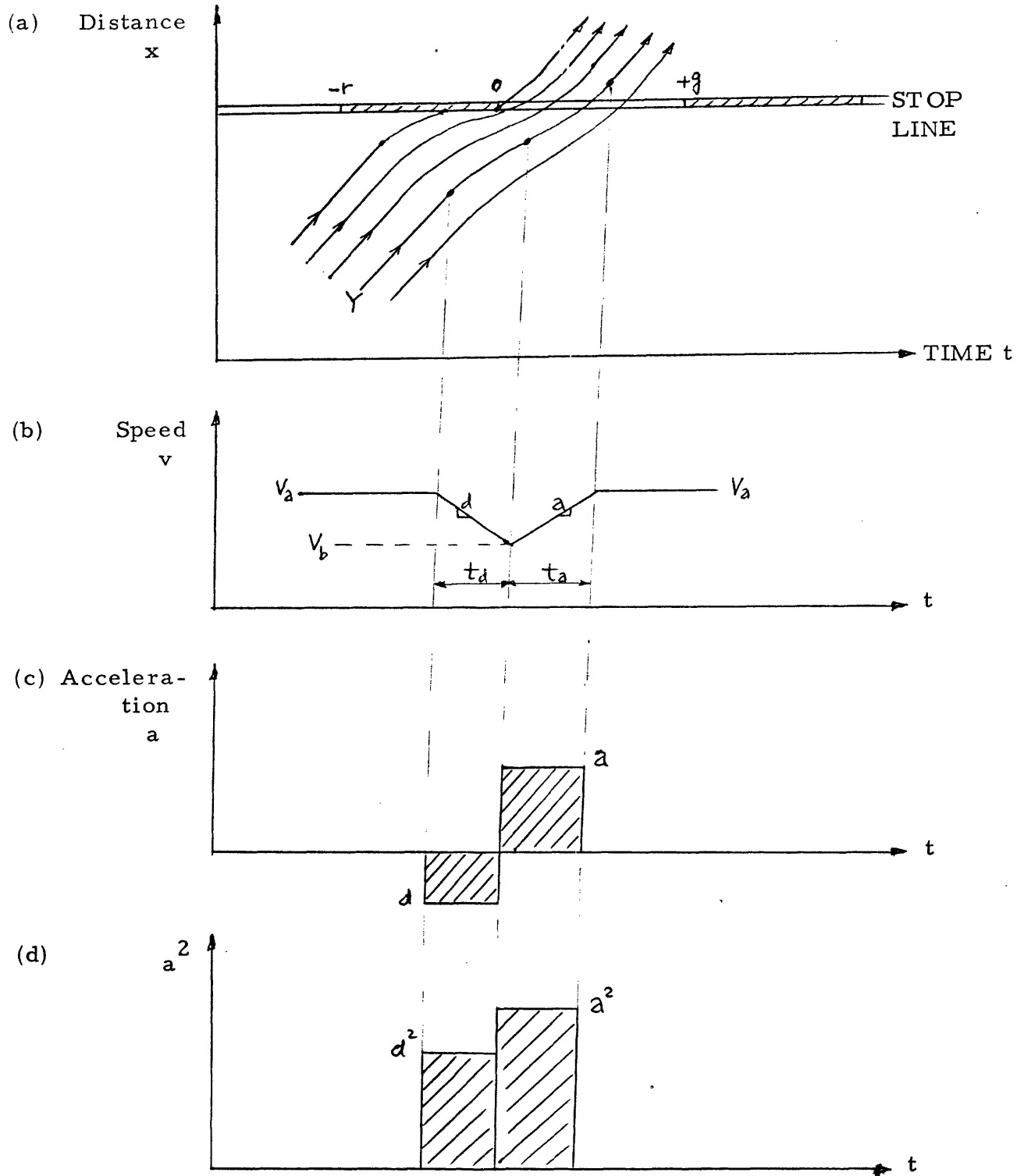
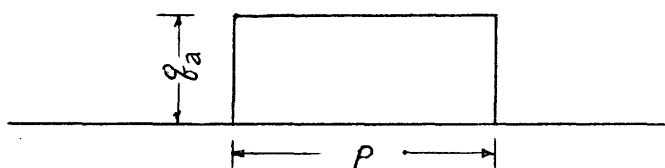

Fig. 2.2 - AN of a platoon; (a) vehicle trajectories; (b) speed variations; (c) & (d) deceleration-acceleration graphs

s = saturation flow rate (veh/sec.)

h_j = headway at jam (when all cars wait at the signal) (ft.)

v_a = normal driving speed of the platoon (ft/sec.)



The slope of line AB (C_d) is equal to $-h_j q_a$. The distance from any point on AB to the stop line is the cumulative queue length at the intersection at any time t . The slope of line OB (C_a) is equal to $-h_j s$.

Line AB goes through point A $(-r, 0)$ and line OB goes through point $O(0, 0)$, so they can be represented as:

Line AB: $x = -h_j q_a (t+r) = C_d (t+r)$

Line OB: $x = -h_j s t = C_a t$

Point B is calculated as $(\frac{C_d}{C_a - C_d} \cdot r, \frac{C_a C_d}{C_a - C_d} \cdot r)$

or $B(C_1 r, C_2 r)$, where

$$C_1 = \frac{C_d}{C_a - C_d} \quad (+) \quad \text{and}$$

$$C_2 = \frac{C_a C_d}{C_a - C_d} \quad (-)$$

If the first car of the platoon arrives at the stop line at time τ , where $-r \leq \tau \leq 0$, then

Line AB: $x = -h_j \varphi_a (t - \tau) = C_d (t - \tau)$

Line OB: $x = -h_j s t = C_a t$

Point B becomes $(-\frac{C_d}{C_a - C_d} \cdot \tau, -\frac{C_a C_d}{C_a - C_d} \cdot \tau)$

or $B(-C_1 \tau, -C_2 \tau)$, where τ is a negative value.

Case I. If $p < g$

1. And if $p \leq r(C_1 + 1 - \frac{C_2}{V_a})$ (See Fig. 3.2(a))

(i.e., last car in the platoon passes through point B, the relation between p and r can be shown as $p = r(C_1 + 1 - \frac{C_2}{V_a})$)

(a) then $-r \leq \tau \leq -p / (C_1 + 1 - \frac{C_2}{V_a})$ (Fig. 3.2(b)) :

$$\text{Number of stops} = \int_0^p \varphi_a dt = p \varphi_a$$

(b) $-p(C_1 + 1 - \frac{C_2}{V_a}) < \tau < 0$ (Fig. 3.2(c)) :

$$\text{Number of stops} = \int_0^{-C_1 \tau} \varphi_a dt = -\varphi_a (C_1 + 1) \tau$$

(c) $0 \leq \tau \leq (g - p)$ (Fig. 3.2(d)) :

Number of stops = 0 (because $p < g$)

(d) $\tau > (g - p)$ (Fig. 3.2(e)) :

Some cars have to stop at the signal and wait until the next green. If we let $p' = \tau - (g - p)$ be the portion of the cars that have to stop at the next red, then $p' = 0$ through p and

$$\text{Number of stops} = \int_0^{p'} \varphi_a dt = \varphi_a \cdot p', \quad \text{where } p' = 0 \sim p$$

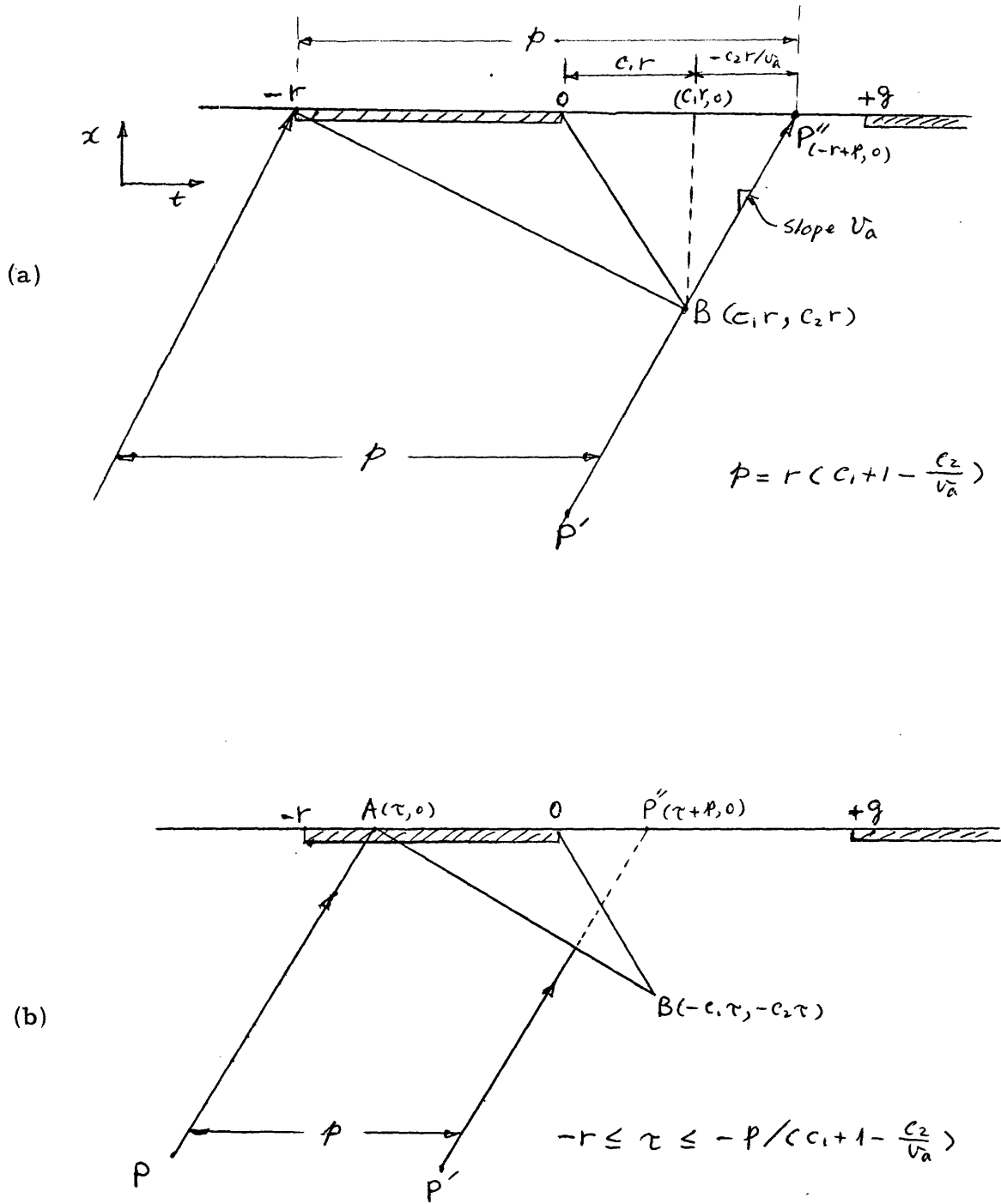
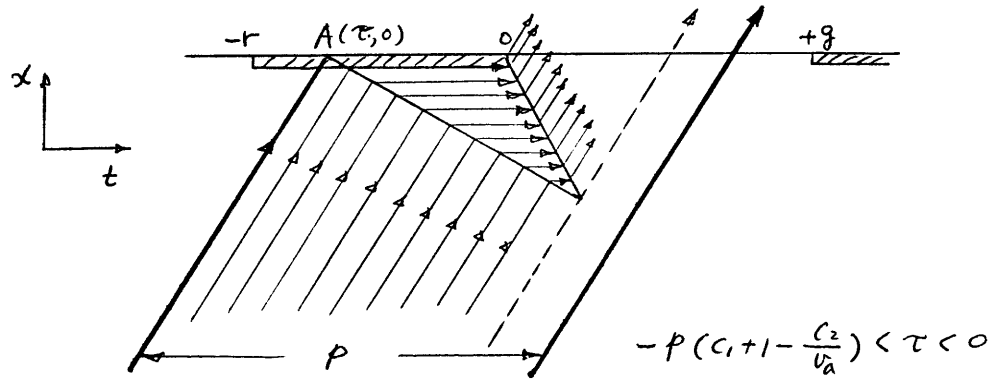
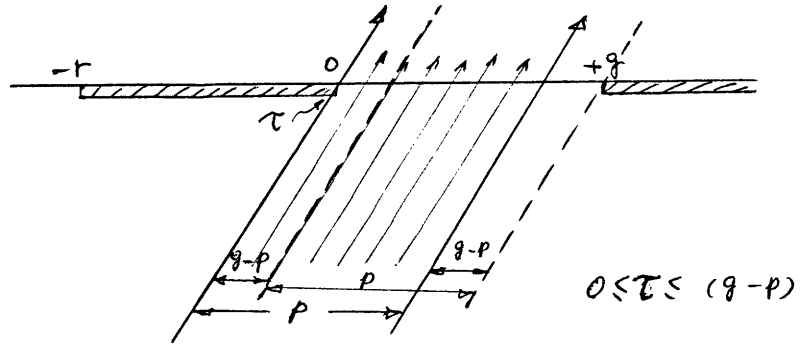

Fig. 3.2 - Platoon Trajectories

(c)



(d)



(e)

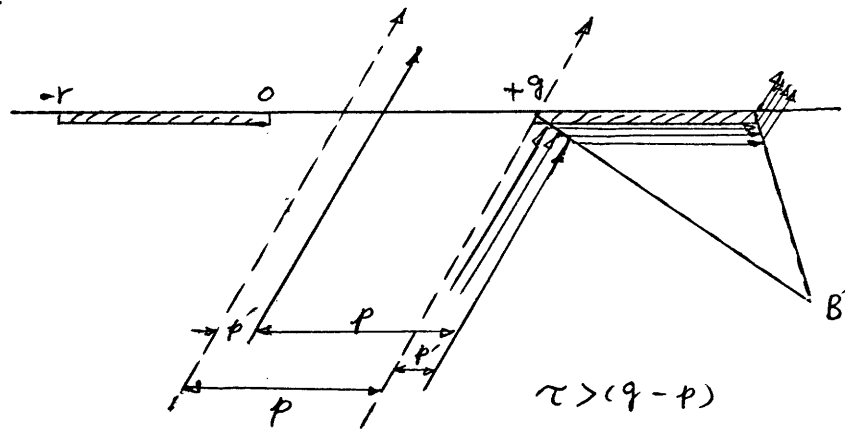

Fig. 3.2 - Platoon Trajectories (cont'd)

The resulting number of stops for this case are shown in Fig.

3.3(a).

2. And if $p > r \left(C_1 + 1 - \frac{C_2}{V_a} \right)$

the calculations are similar and the results are shown in Fig. 3.3(b).

Case II. When $p = g$

Calculations are similar, and the resulting relations are shown in Fig. 3.4.

Case III. When $p > g$

Results for the two cases (a) $p > r \left(C_1 + 1 - \frac{C_2}{V_a} \right)$ and

(b) $p < r \left(C_1 + 1 - \frac{C_2}{V_a} \right)$ are shown in Fig. 3.5.

We are interested in developing the relationships between the number of stops and the offset between the two adjacent signalized intersections. A relationship between the offset Θ and the arrival time of the first car in platoon, τ , can be developed as shown in Fig. 3.6.

Let i, j be the two adjacent intersections. Θ_{ij} is the offset from i to j , Θ_{ji} is the offset in the other direction. Let TTIME be the travel time between i and j for a vehicle traveling at a constant speed v_a . If a car leaves intersection i at the beginning of green, it arrives at the downstream intersection stop line at time τ . (τ is a time relative to the downstream zero time point at the beginning of its green). So we have

$$\Theta_{ij} + \tau = \text{TTIME}$$

$$\text{and } \Theta_{ji} = \text{TTIME} - \tau$$

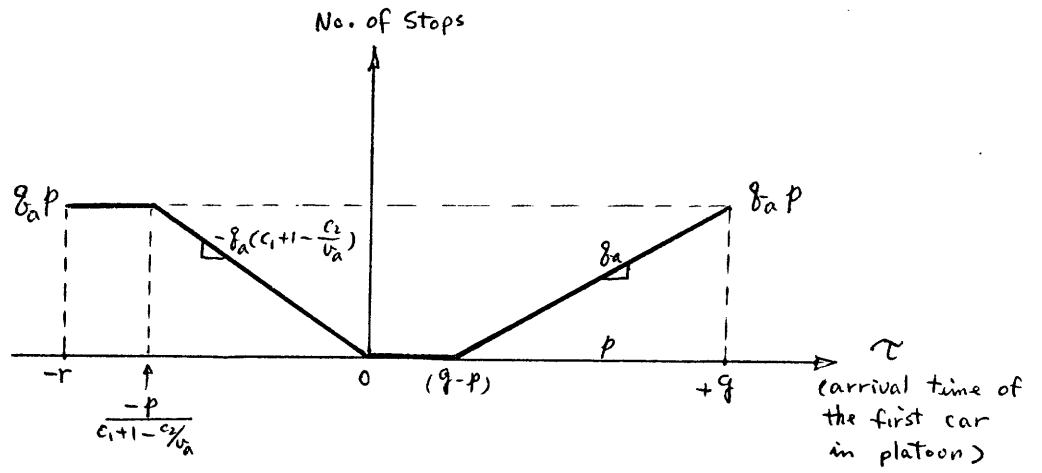

(a) $p < r (C_1 + 1 - \frac{C_2}{v_a})$

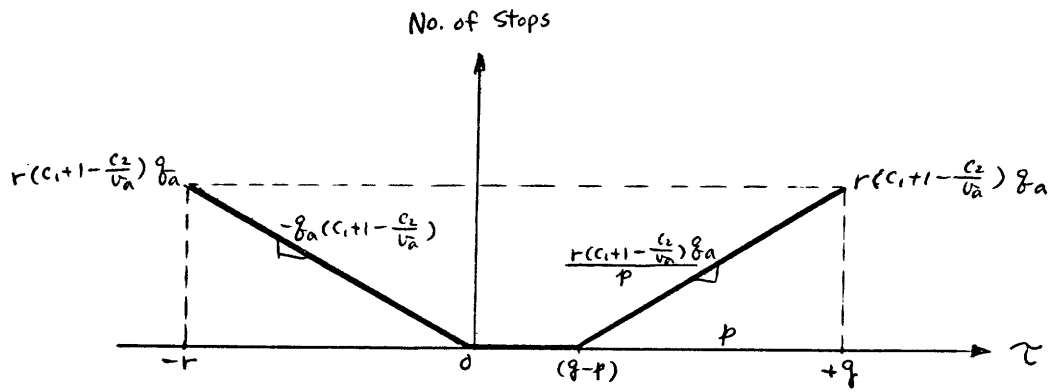

(b) $p > r (C_1 + 1 - \frac{C_2}{v_a})$

Fig. 3.3 - Number of stops for $p < g$

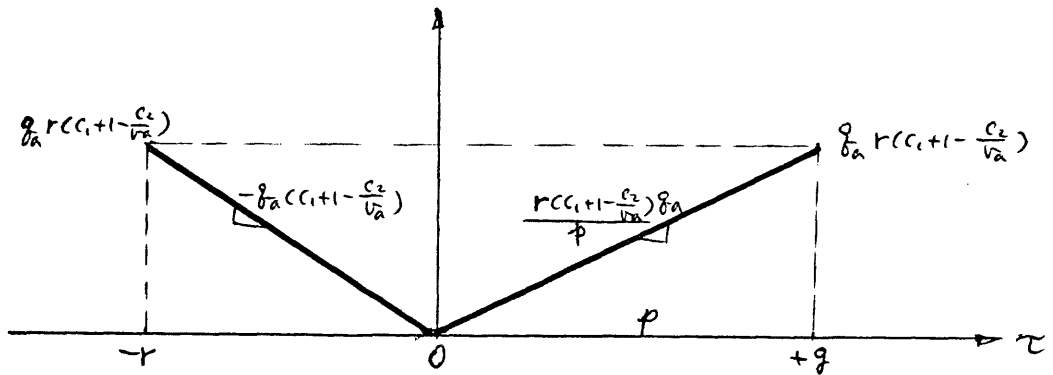
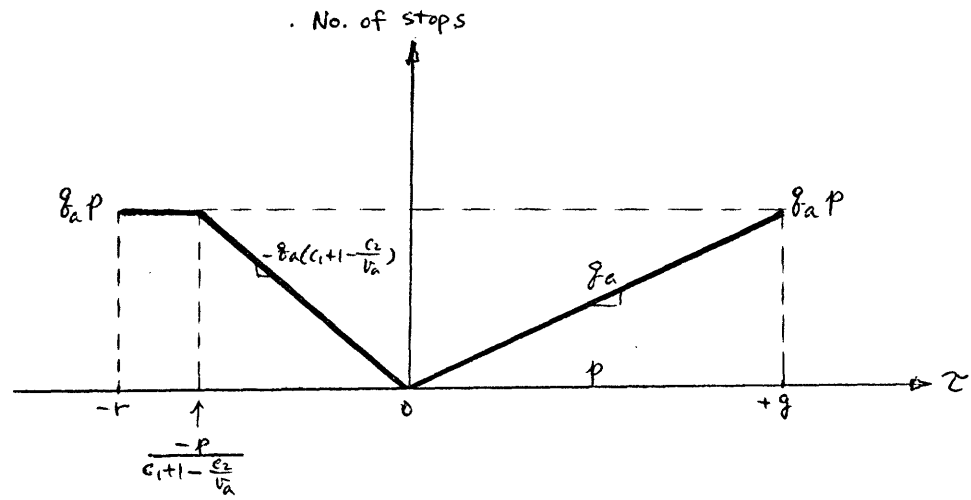
Fig. 3.4 - Number of stops for $p = g$

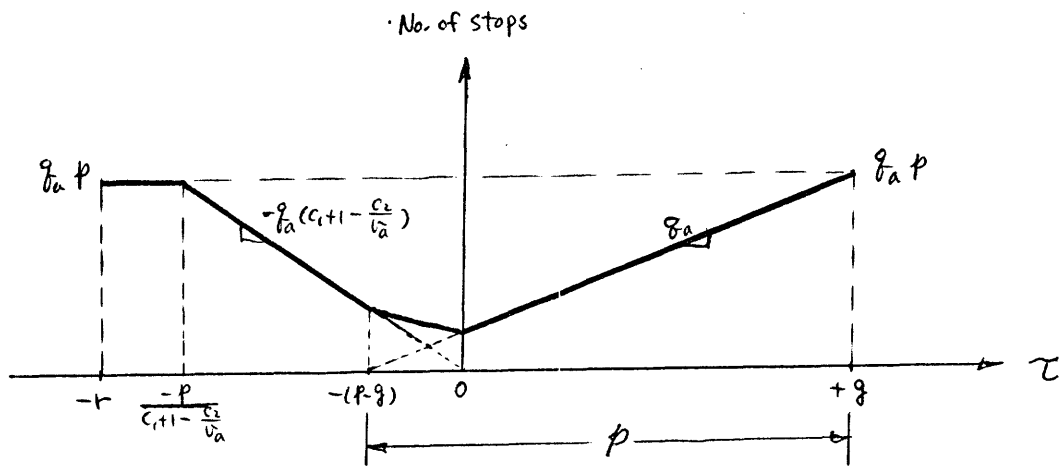

(a) $p < r (C_1 + 1 - \frac{C_2}{v_a})$

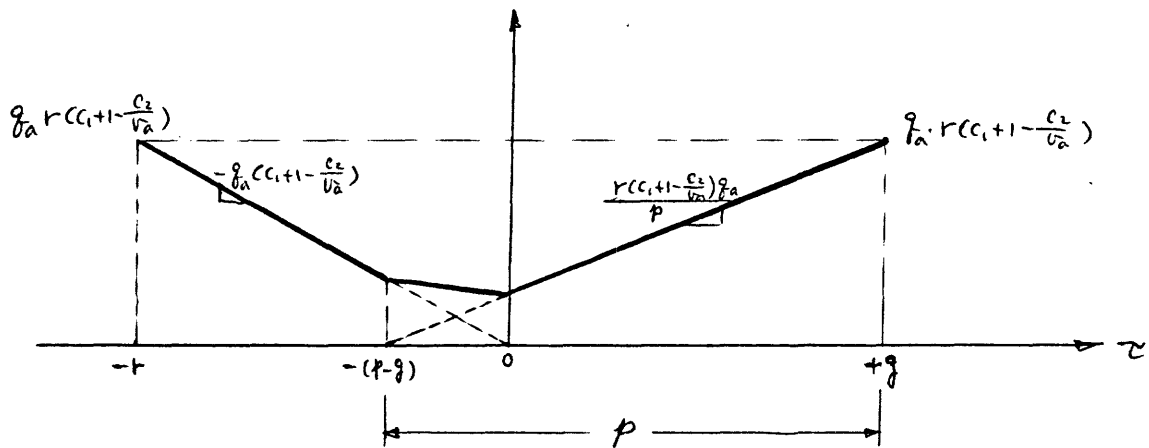

(b) $p > r (C_1 + 1 - \frac{C_2}{v_a})$

Fig. 3.5 - Number of stops for $p > g$

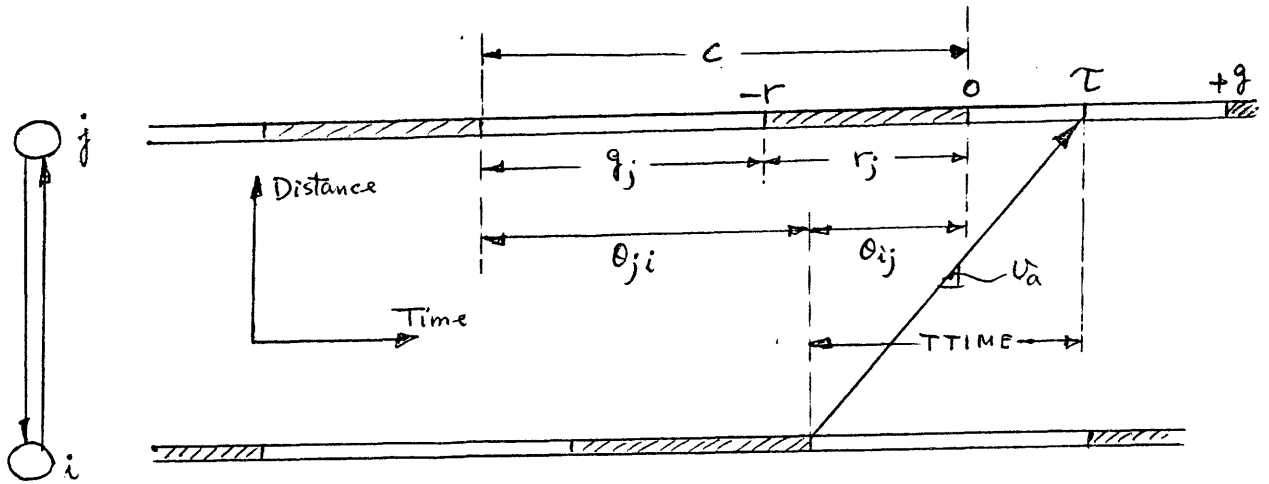

Fig. 3.4 - Links intersections

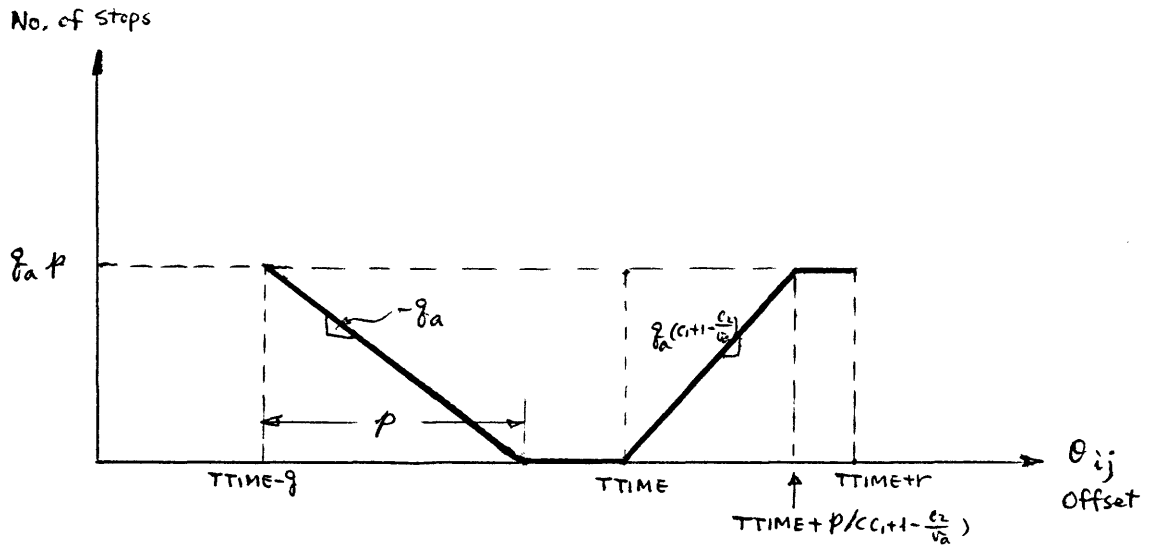
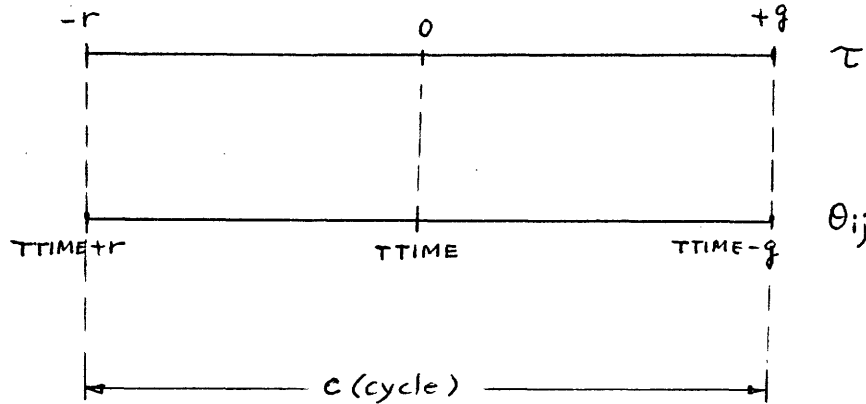

Fig. 3.7 - Relationship between number of steps and offset Q_{ij} for $p < g$ and $p < r (C_1 + 1 - \frac{C_2}{v_a})$

Graphically, the horizontal axes of the figures in the previous sections can be transformed to represent offsets:



All the relations between the number of stops and τ can be changed to relationships between number of stops and the offset Θ_{ij} . As an example, Fig. 3.3a is changed to a relation shown in Fig. 3.7.

4. AN - Additional Assumptions

In order to take a more realistic account of the AN of a platoon of vehicles, we developed a refined model based on additional assumptions. We assume that only cars that join the queue at the stop line while the signal is red come to a full stop and incur a maximum amount of AN. Cars that approach the traffic signal after the light turns green will not join the

standing queue. Instead, they will slow down for a while and accelerate back to their normal speed when they have an unimpeded right-of-way for passing through the intersection. In this manner, these cars will incur only a fraction of the maximum AN that a car that is stopped incurs. Some of the cars arriving later during the green phase may pass without having to change their speed.

Graphically, referring to Fig. 4.1(a), we draw a vertical line OO' from the stop line at time $t = 0$. We assume that the cars that are supposed to arrive at the deceleration-wave line AB at time $t > 0$ do not stop, but instead, they slow down to another constant speed v_b , and start accelerating back to their normal speed v_a at the acceleration wave line OB . So in Fig. 4.1(a), all cars X_1 through X_n have to stop, while car Y_1 , (with $t_{c1} > 0$), does not. Y_1 changes to the lower speed v_b at $t = 0$ (point E) and travels at that speed v_b until it joins the acceleration line OB at point F, then it starts accelerating back to its normal speed v_a . The slope of EF represents the speed v_b . Cars such as Z_1 and Z_2 can pass through without any change in speed.

We assume that the speed of the cars that do stop, becomes zero at the deceleration line AB , and they remain in this state until the acceleration line OB , when they start accelerating. For the cars that only slow down for a while and speed up again, the speed changes occur at line $t = 0$ and OB (see Fig. 4.1(b)). The time-distance diagrams in this chapter show only the simplified trajectories of the car movements. The acceleration and deceleration processes are not shown.

The AN of a discrete arrival flow and a uniform arrival flow are considered in this chapter. A model to calculate the AN for a random arrival flow is developed in the next chapter.

4.1. Discrete Arrivals

As in Fig. 4.1, for cars that stop (i.e., cars X_1 through X_n) the deceleration time is $t_d = v_a/d$ and the acceleration time is $t_a = v_a/a$. d is a constant deceleration rate and a is a constant acceleration rate. For each one of these cars we have the following AN relation:

$$\sigma^2 = \frac{1}{T} \int_0^T [a(t)]^2 dt = \frac{1}{t_d + t_a} [d^2 t_d + a^2 t_a]$$

For the cars that only slow down and accelerate back to their normal speed, (such as cars Y_1, Y_2 , and Y_3), the AN is calculated as follows:

$$\text{Line AB: } x = C_d (t - \tau)$$

$$\text{Line OO': } t = 0$$

Solving lines AB and OO' for point C', we get $x_{C'} = -C_d \tau$ and $t_{C'} = 0$. Line C' M goes through point C' and has a slope v_a . Line EN goes through point $(t_{C'} + h, x_{C'})$, i.e., point $(h, -C_d \tau)$, where h is the arrival headway (sec.) and has slope v_a , so that.

$$\text{Line EN: } \frac{x + C_d \tau}{t - h} = v_a$$

$$\text{i.e., } x = v_a t - v_a h - C_d \tau$$

Solving lines OO' and EN for point E, we get $x_E = -v_a h - C_d \tau$ and $t_E = 0$. Solving lines AB and EN for point C', we get $t_{C'} = \frac{v_a h}{v_a - C_d}$ and $x_{C'} = C_d \left(\frac{v_a h}{v_a - C_d} - \tau \right)$.

$$\text{Line C'F: } x = x_{c'} = c_d \left(\frac{v_a h}{v_a - c_d} - \tau \right)$$

$$\text{Solving lines C'F and OB for point F, we get } t_F = \frac{c_d}{c_a} \left(\frac{v_a h}{v_a - c_d} - \tau \right)$$

$$\text{and } x_F = c_d \left(\frac{v_a h}{v_a - c_d} - \tau \right).$$

$$\text{Line EF: } \frac{x - x_F}{t - t_F} = \frac{x_E - x_F}{t_E - t_F}$$

and the slope of line EF, which is v_b for car Y_1 , is

$$v_b = \frac{x_E - x_F}{t_E - t_F} = \frac{c_a v_a^2 h}{c_d (v_a h - v_a \tau + c_d \tau)}$$

If we let $(t_d)_{Y_1}$ denote the deceleration time of car Y_1 and $(t_a)_{Y_1}$ denote its acceleration time, then from the relationship $v_b = v_a - d (t_d)_{Y_1}$

and $v_a = v_b + a (t_a)_{Y_1}$ we obtain

$$(t_d)_{Y_1} = \frac{v_a - v_b}{d}$$

$$(t_a)_{Y_1} = \frac{v_a - v_b}{a}$$

respectively, and the AN of Y_1 can be represented by:

$$\sigma_{Y_1}^2 = \frac{1}{(t_d)_{Y_1} + (t_a)_{Y_1}} [d^2 (t_d)_{Y_1} + a^2 (t_a)_{Y_1}]$$

For car Y_2 , the calculations are similar to that for Y_1 . Since Y_2 comes h seconds later than Y_1 , we simply replace h by $2h$ in the above derivations and obtain v_b for Y_2 , $(t_d)_{Y_1}$, $(t_a)_{Y_1}$ and finally $\sigma_{Y_2}^2$.

We do the same calculations for the cars that follow until the time $t_{c'} > t_B$ when all cars can pass through without changing their speed, and therefore, do not incur any AN.

4.2 Uniform Arrivals

We assume a uniform arrival flow pattern with magnitude q_a and duration p . We divide the platoon length into N intervals Δt .

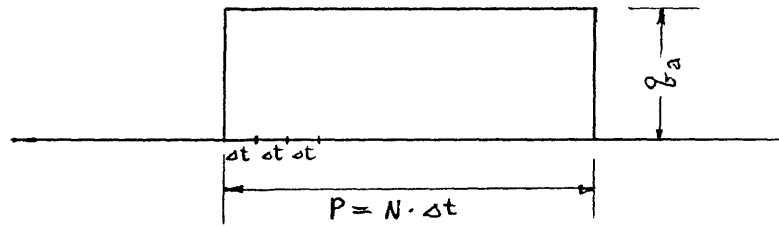

Assuming the arrival time of the first group of vehicles (q_a in Δt) at the stop line is τ (Fig. 4.2), then the arrival time of any n th group at the deceleration wave line $A'B'$ is $t_{c''}$.

$$\text{Line } A'B': \quad x = C_d (t - \tau)$$

$$\text{Line } KK': \quad \frac{x - 0}{t - \tau - (n-1)\Delta t} = V_a$$

$$\text{i.e.,} \quad x = V_a [t - \tau - (n-1)\Delta t]$$

Solving line $A'B'$ and KK' for point C'' , we have

$$t_{c''} = \frac{V_a (n-1) \Delta t}{V_a - C_d} + \tau$$

$$x_{c''} = \frac{C_d \cdot V_a (n-1) \Delta t}{V_a - C_d}$$

- (I) For $t_{c''} = t_A$, through $t_{c'}$, i.e., $\tau \leq t_{c''} \leq 0$: All arriving cars have to stop, and the AN of any group of $q_a \cdot \Delta t$ cars can be calculated as follows:

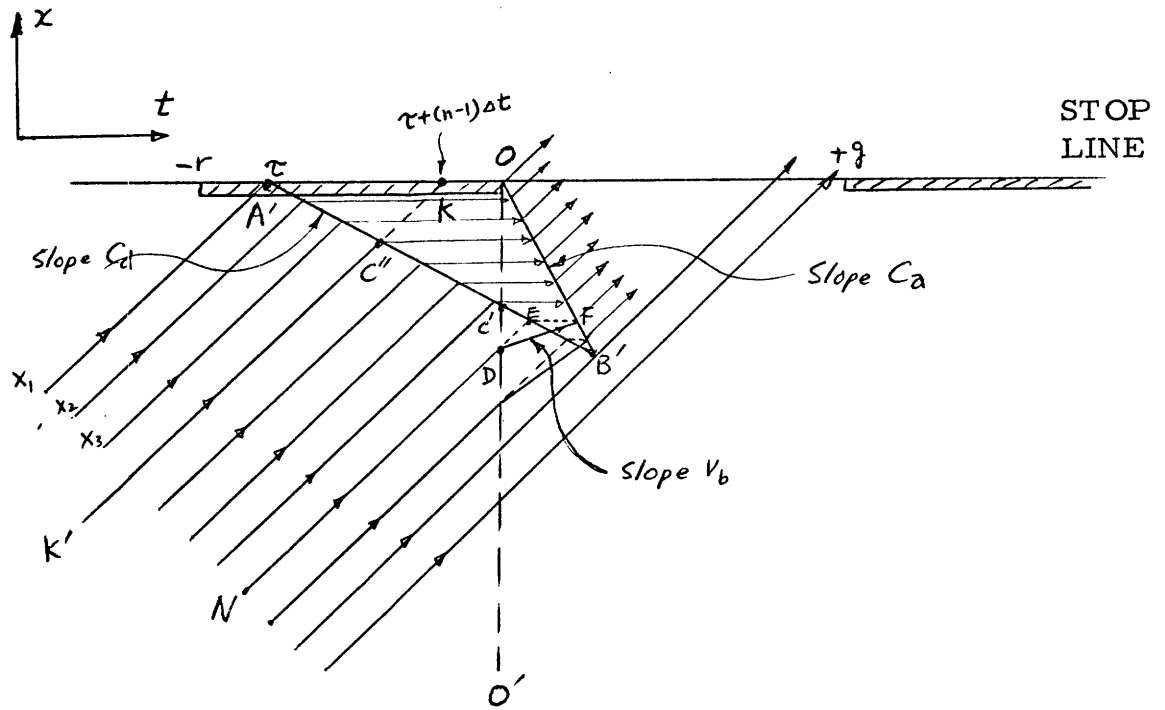

Fig. 4.2 - Uniform Arrivals

deceleration time $t_d = v_a / d$

acceleration time $t_a = v_a / a$

and
$$\sigma^2 = \frac{1}{t_d + t_a} [d^2(t_d) + a^2(t_a)] \cdot (\rho_a \cdot \Delta t)$$

(II) For $t_c'' > t_c' = 0$ through $t_b' = -C_1 \tau = \frac{-C_d \tau}{C_a - C_d}$:

these cars do not come to a full stop, but only slow down to a lower speed v_b :

Calculations for v_b and σ_b are similar to those in the discrete arrival case.

The total AN is then the summation of the AN's of the individual groups of cars in (I) and (II).

5. Computer Model and Program to Calculate Acceleration
Noise for Continuous Flow Patterns

Assuming that:

1. We are given a dispersed input flow, which is the flow pattern discharged from the upstream intersection, at a distance:

$$\text{DIST} = \text{HDWYJ} \times \text{SUMO1}$$

from the stop line, where

$$\text{HDWYJ} = \text{headway at jam} = h_j \text{ (ft/veh.)}$$

$$\text{SUMO1} = \text{total number of cars in the arrival platoon (veh.)}$$

This flow can be either a result of field measurements or an output from another computer program.

2. The assumptions of Chapter 4 hold.

The arrival flow is given throughout a whole cycle length. We can divide the cycle length into many small increments.

$$\text{CYCLE} = \text{cycle length (sec.)}$$

$$\text{RED} = \text{effective red time (sec.)}$$

$$\text{GREEN} = \text{effective green time (sec.)}$$

$$\text{ITIME} = \text{length of each time increment (sec.),}$$

we can use, say, 2 sec.

$$\begin{aligned} \text{NINC} &= \text{total number of increments in the cycle} \\ &= \text{CYCLE/ITIME} \end{aligned}$$

$P2(n)$ = number of cars in the n th increments
 $SPEED$ = normal, constant speed = v_a (ft/sec.)
 SF = saturation flow = discharging rate after
 signal turns green and before queue
 disappears (veh/sec.)

Referring to Fig. 5.1, $P2(1)$ is the first group of cars. $P2(1)$ arrives at the stop line at time $T_1 = -RED$ (the beginning of green is zero time). $P2(2)$ is the second group of cars, they arrive and join the queue (queue length = $h_j \times P2(1)$) at time T_2 . And so on. $P2(n)$ is the n th group of cars, and its arrival time at the queue is $T_n > 0$. As soon as the signal turns green at time $t = 0$, cars start leaving the intersection at the saturation flow rate SF . We assume that $P2(n)$ with $T_n > 0$ do not come to a complete stop, they change to the lower speed v_b at $t_D = 0$, and start accelerating at point E.

To calculate the arrival time of each group of cars at the queue, we let the arrival times be T_1, T_2, \dots , and further assume that the first group of cars arrive at time $T_1 = -RED$ (see Fig. 5.2). Let $SPEED$ denote the normal driving speed, then $TIME = DIST/SPEED$ is the travel time to go through the distance $DIST$. Then,

$$\begin{aligned}
 A_2 T_2 &= ITIME - \left\{ TIME - \frac{DIST - h_j \times P2(1)}{SPEED} \right\} \\
 A_3 T_3 &= 2 ITIME - \left\{ TIME - \frac{DIST - h_j \times [P2(1) + P2(2)]}{SPEED} \right\} \\
 &\vdots
 \end{aligned}$$

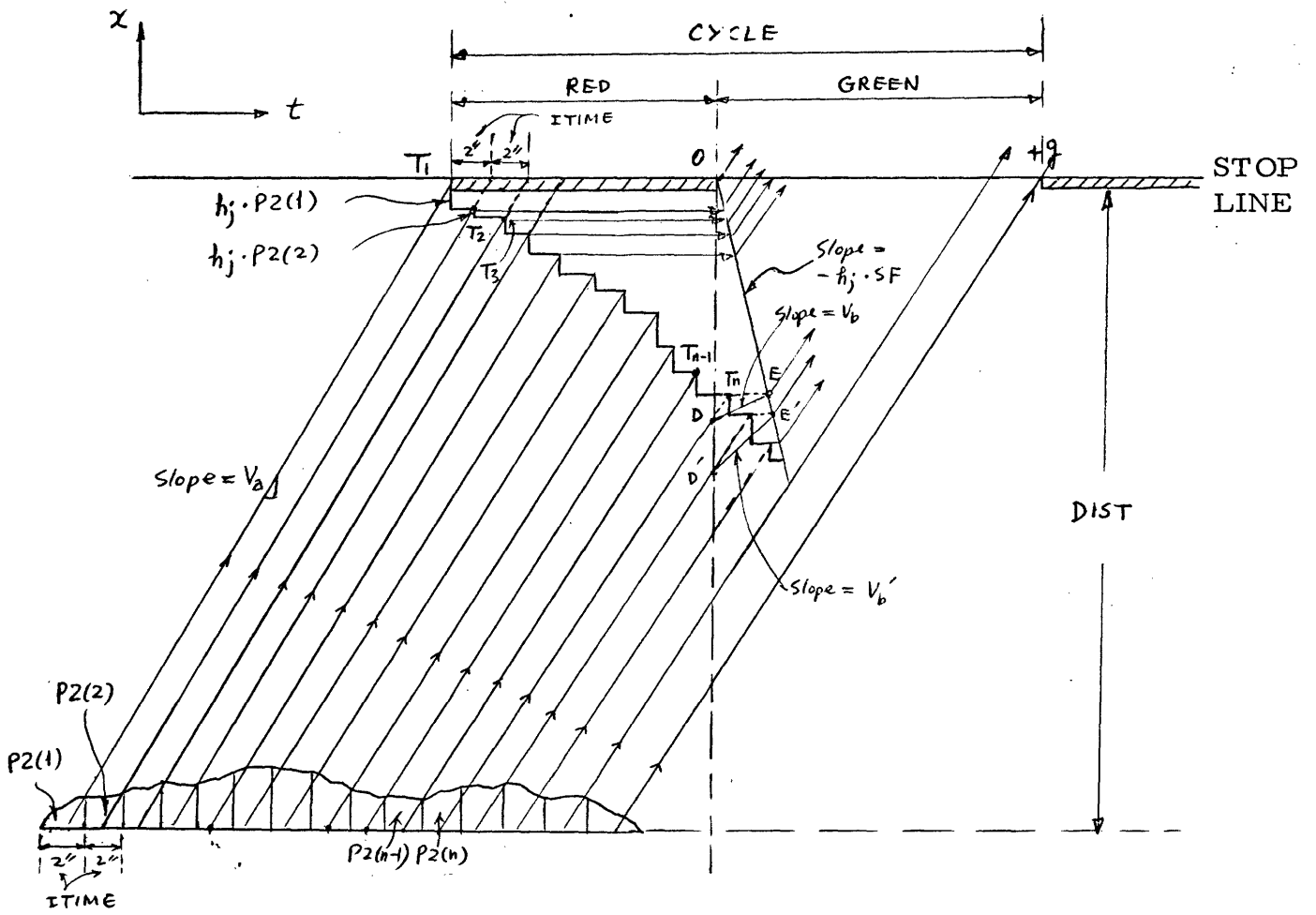

Fig. 5.1 - Continuous arrival flow

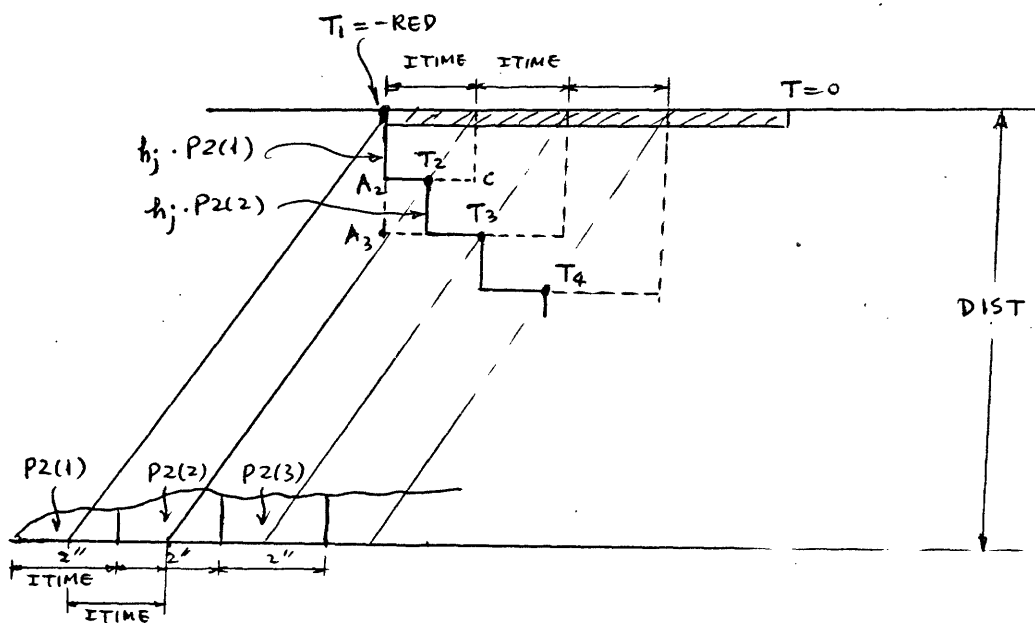

Fig. 5.2 - Arrival times at the queue

So the arrival time of the nth group of cars at the queue is

$$T_n = -RED + (n-1) ITIME - \left\{ TIME - \frac{DIST - h_j \times [Q(n-1)]}{SPEED} \right\}$$

Where $Q(n-1)$ is the cumulative number of cars in the queue for groups 1 through $(n-1)$, i.e.,

$$Q(n-1) = P2(1) + P2(2) + \dots + P2(n-1)$$

At time $t = 0$, i.e., as the signal turns green, the vehicles start leaving at saturation flow rate SF . The queue keeps increasing from time $= -RED$ to time $= 0$. After time $t = 0$, the queue keeps decreasing at the rate $SF - \text{Input Flow}$, until the queue disappears or $t = GREEN$; then we start the next cycle. So after time $t = 0$, queue $= Q(n) - SF$ and queue

To calculate v_b , we refer to Figs. 5.1 and 5.3. Suppose $T_n > 0$. According to our assumptions, $P2(n)$ does not stop, this group of cars slows down to a lower speed v_b at time $t = 0$ (i.e., at point D) and accelerates back to normal speed v_a at point E. The slope of line DE represents this lower speed v_b . Fig. 5.3 shows this part in more detail. OP represents the time $t = (n-1)ITIME - RED$, and OD represents the distance $= v_a \cdot [(n-1)ITIME - RED]$. The distance of point E from the stop line is:

$$EDIST = h_j \times Q(n-1)$$

At point E:

$$EDIST = h_j \times SF \times ETIME$$

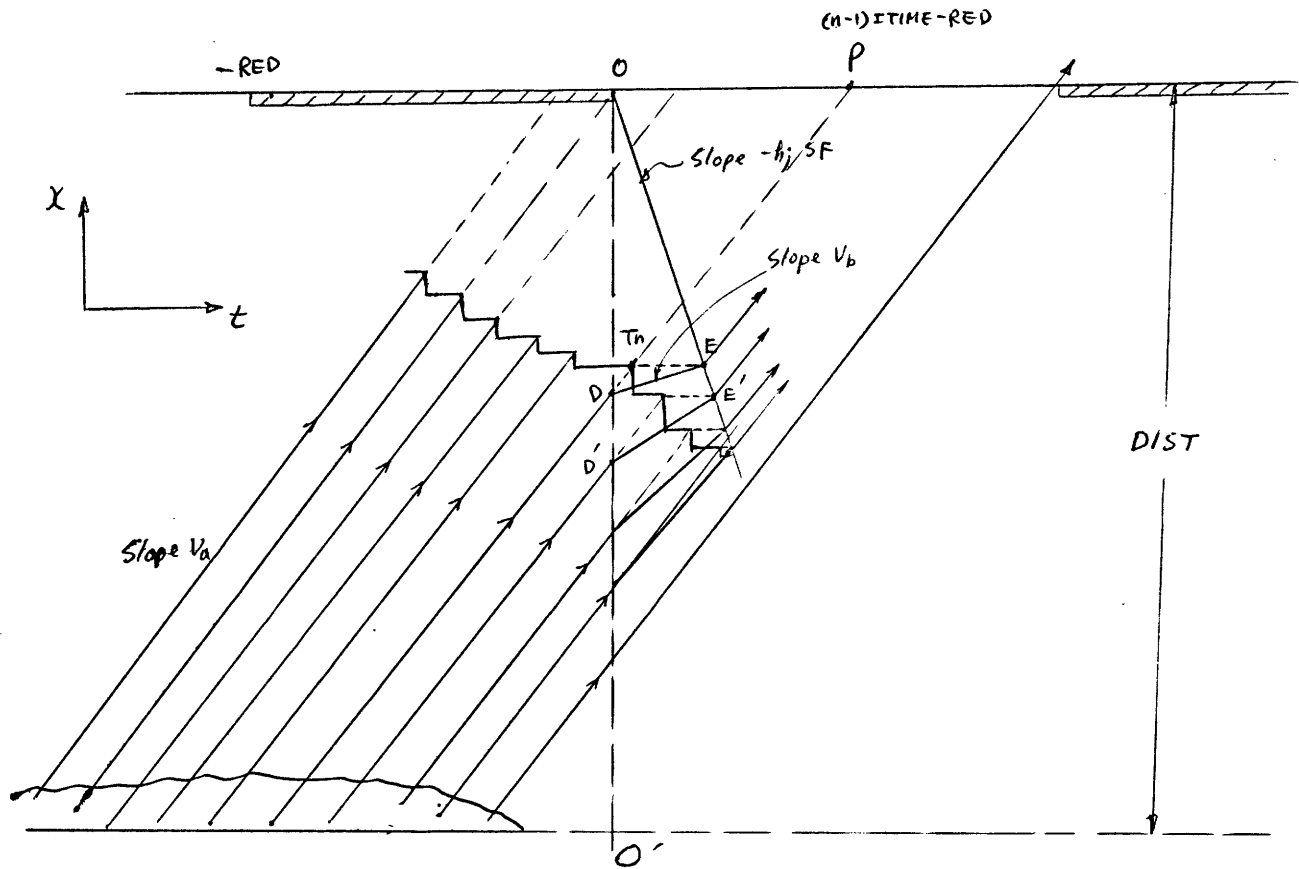

Fig. 5.3 - Trajectories near time $t = 0$

so,

$$ETIME = EDIST / (h_j \times SF).$$

Therefore, in time ETIME, this nth group of cars P2(n) travels the distance (OD - EDIST), and we obtain

$$v_b = \text{slope of DE} = \frac{OD - EDIST}{ETIME}$$

The calculation of the AN can be summarized as follows:

(1) For groups of cars that join the queue at time $T_n \leq 0$:

$$AN = \left\{ \frac{1}{t_d + t_a} [d^2 t_d + a^2 t_a] \right\}^{1/2} P2(n)$$

where $t_d = v_a / d$ and $t_a = v_a / a$.

(2) For groups of cars that are supposed to join the queue at time

$T_n > 0$, before the queue disappears:

they change to lower speed v_b at time $t = 0$ and each

group has the AN:

$$AN = \left\{ \frac{1}{t_d + t_a} [d^2 t_d + a^2 t_a] \right\}^{1/2} P2(n)$$

where

$$t_d = \frac{v_a - v_b}{d}$$

$$t_a = \frac{v_a - v_b}{a}$$

and v_b is calculated by equation as above.

(3) For groups of cars that arrive after the queue disappears:

they pass through the intersection without any change in

speed and hence $AN = 0$ for these cars.

Based on the model developed above, a computer program was written to calculate the AN for any arrival flow pattern. The program is a FORTRAN subroutine. It can be easily called from a main FORTRAN program which has the distribution of the arrival flow and other basic data such as cycle time, red time, green time, speed, etc. One example of such a main program is the program in Ref. (6), that calculates the delay at the intersection.

A flowchart showing the logic of how the AN is calculated in the program, together with the definition of variables and a complete listing are shown in Appendix A. A subroutine that shifts the arrival platoon takes care of the effects of changing the offset.

The results of an actual computer run are shown in Appendix B. Part (a) shows the arrival flow pattern P2, in which the total number of cars is 14.56/cycle. Part (b) shows the calculated acceleration noise for different offsets.

Appendix A
The Computer Program
(a) Flow Chart

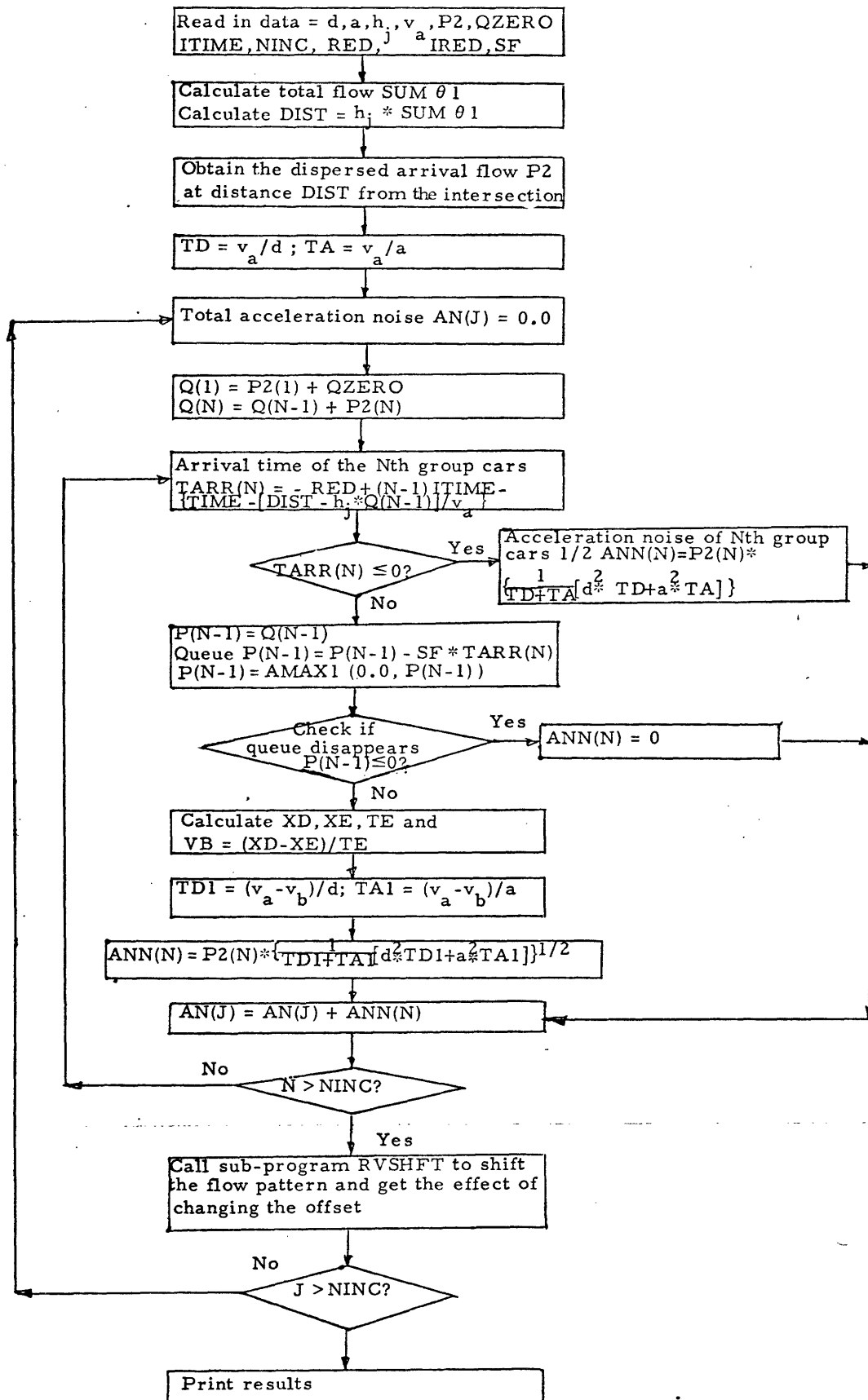

APPENDIX A

The Computer Program

(b) Definition of Variables

DRATE	=	d	=	deceleration rate (ft/sec ²)
ARATE	=	a	=	acceleration rate (ft/sec ²)
HDWYJ		h_j	=	headway at jam (ft/veh.)
SPEED		v_a	=	the constant arrival speed (ft/sec)
P2(I)	=			total number of cars in the Ith group (veh.)
Q(I)	=			cumulative number of cars from 1st to Ith group (veh.)
QZERO	=			secondary flow (veh.)
TARR(I)	=			the arrival time at the queue of the Ith group (sec)
P(I)	=			number of cars left in the queue after signal turns green (veh.)
SF	=			saturation flow (veh/sec)
ITIME	=			the length of each time increment (sec)
NINC	=			total number of increments (the cycle time is divided into NINC increments of ITIME seconds each)
RED	=			length of the red period (sec)
IRED	=			number of increments in RED
ANN(N)	=			the individual acceleration noise of the Nth group
AN	=			total acceleration noise (ft/sec ²)

Appendix A

(c) Listing of Program

```

145     SUBROUTINE ANDISE (P2,Q,SPEED,NINC,ITIME,RED,QZERO,TRED,HDWYJ,SF1
      *,IWORK,X,SF,DIST)
146     DIMENSION ANN(120),AN(120),P2(120),Q(120),IWORK(120),X(120),
      *TARR(120),P(120)
147     DATA DRATE/8.0/,ARATE/5.0/
148     TD=SPFED/DRATE
149     TA=SPFED/ARATE
150     TIME=DIST/SPEED
151     TEMP=((1.0/(TD+TA))*(DRATE**2*TD+ARATE**2*TA)**0.5
152     DO 700 J=1,NINC
153     Q(J)=P2(J)+QZERO
154     AN(J)=0.0
155     ANN(1)=P2(1)*TEMP
156     AN(J)=AN(J)+ANN(1)
157     LIM=NINC
158     DO 600 IT=2,NINC
159     Q(IT)=Q(IT-1)+P2(IT)
      CCC     NOTE: BECAUSE THE ARRIVAL FLOW IS FOR 2 LANES, WE USE HDWYJ/2
      CCC     IN THE CALCULATIONS.
160     TEMP2=TIME-(DIST-HDWYJ/2*Q(IT-1))/SPEED
161     TAPR(IT)=(-1.0*RED)+(IT-1)*ITIME-TEMP2
162     IF (TARR(IT)-0.0) 77,77,78
163     77 ANN(IT)=P2(IT)*TEMP
164     GO TO 600
165     78 P(IT-1)=Q(IT-1)
166     P(IT-1)=P(IT-1)-SF*TAPR(IT)
167     P(IT-1)=AMAX1(0.0,P(IT-1))
168     IF(P(IT-1)-0.0) 70,70,71
169     71 XD=SPEED*((IT-1)*ITIME-RED)
170     XF=HDWYJ/2*Q(IT-1)
171     TE=XF/(HDWYJ/2*SF)
172     VB=(XD-XF)/TE
173     TD1=(SPFED-VB)/DRATE
174     TA1=(SPEED-VB)/ARATE
175     PRINT727,TD1,TA1,VB,SPEED,XD,XE,TE,IT
176     727 FORMAT('0',' TD1= ',F7.2,' TA1= ',F7.2,' VB= ',F7.2,' SPEED= ',F7.2,
      *' XD= ',F10.2,' XE=',F10.2,' TE= ',F7.2,10X,' IT= ',I5)
177     TEMP1=((1.0/(TD1+TA1))*(DRATE**2*TD1+ARATE**2*TA1)**0.5
178     ANN(IT)=P2(IT)*TEMP1
179     GO TO 600
180     70 ANN(IT)=0.0
181     LIM=IT
182     GO TO 747
183     600 AN(J)=AN(J)+ANN(IT)
184     747 PRINT737
185     737 FORMAT('0',' TARR(ARRIVAL TIME)= ')
186     PRINT,(TARR(IT),IT=2,LIM)
      CCC     CHANGE OFFSET
187     CALL RVSHFT (P2,NINC)
188     700 CONTINUE
189     PRINT710
190     710 FORMAT ('0',' ACCELERATION NOISE FOR OFFSETS IS : ')
191     PRINT,(AN(J),J=1,NINC)
192     CALL QKRPLT (X,AN,NINC,0,0,IWORK)
193     RETURN
194     END

```

No. of Vehicles

Total No. of cars in platoon = 14.56

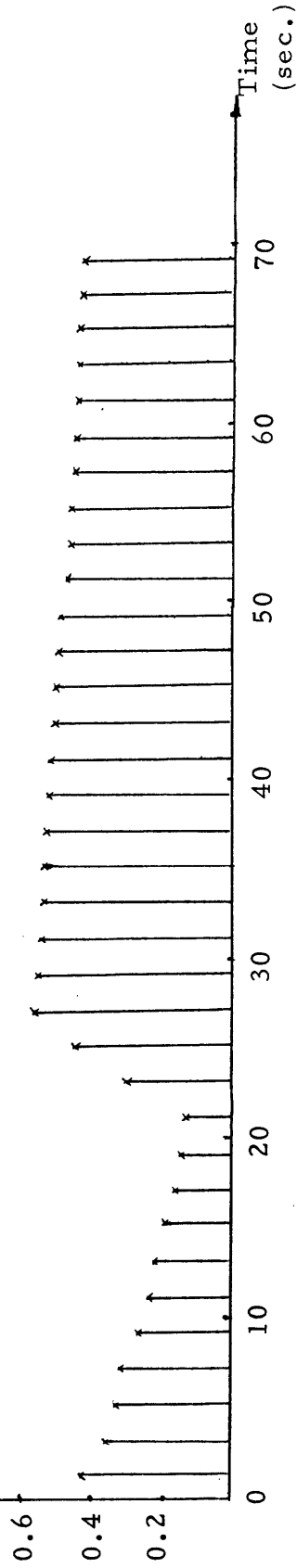

(a) Arrival Flow P2

AN² (ft/sec²)

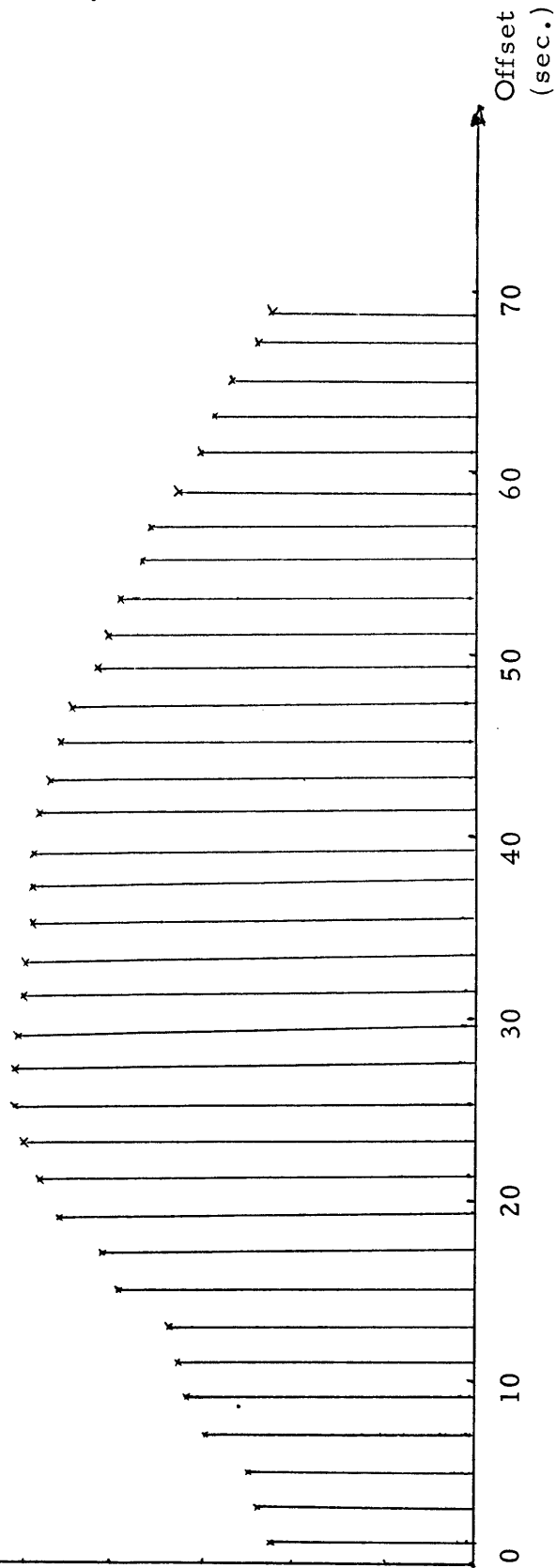

(b) Acceleration Noise vs. Offset

References

1. D. R. Drew, "Traffic Flow Theory and Control," McGraw-Hill, New York, 1968.
2. E. W. Montroll, "Acceleration Noise and Clustering Tendency of Vehicular Traffic," Theory of Traffic Flow (R. Herman, ed.), Elsevier, Amsterdam, 1961.
3. E. W. Montroll and R. B. Potts, "Car Following and Acceleration Noise," HRB Special Report 79 (Ch.2), Washington D.C., 1964.
4. T. R. Jones and R. B. Potts, "The Measurement of Acceleration Noise - A Traffic Parameter," Operations Research, 745-763, 1962.
5. W. Helly and P. G. Baker, "Acceleration Noise in a Congested Signalized Environment," Vehicular Traffic Science (L.C. Edie et al, eds.), American Elsevier, New York, 1967.
6. N. Gartner, "Platoon Profiles and Link Delay Functions for Optimal Coordination of Traffic Signals on Arterial Streets," Res. Report No. 9, University of Toronto - York University Joint Program in Transportation, August 1972.
7. "SIGOP: Traffic Signal Optimization Program; A computer program to calculate optimum coordination in a grid network of synchronized traffic signals; Traffic Research Corporation, New York, September 1966, PB 173 738.
8. D. I. Robertson, "TRANSYT Method for Area Traffic Control," Traffic Engineering and Control, October 1969.
9. M. J. Lighthill and G. B. Whitham, "On kinematic waves: A theory of traffic flow on long crowded roads," Proc. Royal Soc., A229, No. 1178, 317-345, 1955.