

Additive Assembly of Digital Materials

By Jonathan Ward

Submitted to the Program In Media Arts and Sciences,
School of Architecture and Planning,
in Partial Fulfillment of the Requirements for the Degree of

Master of Science in Media Arts and Sciences
at the
Massachusetts Institute of Technology

September 2010

© 2010 Massachusetts Institute of Technology
All rights reserved.

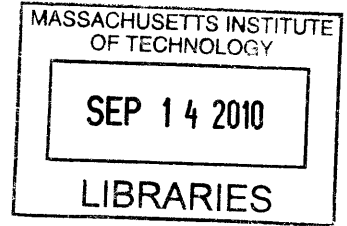

ARCHIVES

Author.....

Program in Media Arts and Sciences,
School of Architecture and Planning
Aug 6, 2010

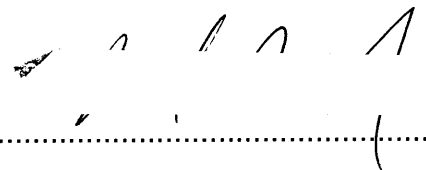
Certified by.....

Neil Gershenfeld
Thesis Supervisor
Director Center for Bits and Atoms
Professor of Media Arts and Sciences

Accepted by.....

Professor Pattie Maes
Associate Academic Head
Program in Media Arts and Sciences

Additive Assembly of Digital Materials

By Jonathan Ward

Submitted to the Program In Media Arts and Sciences,
School of Architecture and Planning,
in Partial Fulfillment of the Requirements for the Degree of

Master of Science in Media Arts and Sciences
at the
Massachusetts Institute of Technology

September 2010

© 2010 Massachusetts Institute of Technology
All rights reserved.

Abstract

This thesis develops the use of additive assembly of press-fit digital materials as a new rapid-prototyping process. Digital materials consist of a finite set of parts that have discrete connections and occupy discrete space. Part geometries were designed and fabricated at different scales from different materials, including hierarchical voxels which connect across different scales. All parts were designed to be vertically assembled with top and bottom connections. Digital materials are discussed as a new way for building physically reconfigurable, multi-material 3D structures. The parts were designed with press-fit connectors to build reversible assemblies to take full advantage of reuse and recycling. This document starts by describing some current technologies in the fields of rapid-prototyping and personal fabrication. The concept for a press-fit digital materials is defined and explained. Many part designs are documented, including conductor and insulator parts for SOIC-pitch 3D circuits and hierarchical assemblies. This thesis concludes with the design and concept for assembly machine to automate building functional digital materials.

Neil Gershenfeld
Thesis Supervisor
Director Center for Bits and Atoms
Professor of Media Arts and Sciences

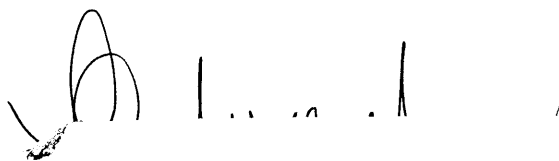

Thesis Reader.....

Jonathan Bachrach, PHD
Senior Research Scientist
Other Lab

Thesis
Reader.....

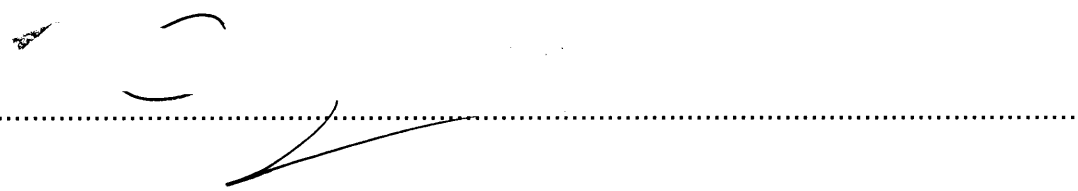
A handwritten signature in black ink, consisting of several fluid, connected strokes, positioned above a horizontal dotted line.

George A. Popescu
Chief Executive Officer
Boston Technologies

Acknowledgments

I would like to thank Neil Gershenfeld and everyone in the Physics and Media research group, the Center for Bits and Atoms, and the global Fab Lab network.

A special thanks goes to all of the individuals I've worked with at the Media Lab and the many other departments at MIT as well as all of the amazing people I've learned from and been inspired by throughout all of my work, travel, and life experiences.

Table of Contents

Abstract.....	7
1 Introduction.....	7
1.1 CNC Fabrication.....	7
1.2 Personal Fabrication.....	8
1.3 Machines that Make.....	8
2 Background.....	10
2.1 Additive vs. Subtractive.....	10
2.2 Analog vs. Digital.....	11
3 Digital Materials.....	11
3.1 Error-Reducing Materials.....	11
3.2 Multiple Materials.....	12
3.3 Reversible.....	13
4 Press-Fit.....	15
4.1 GIK.....	16
4.2 Part Design.....	17
4.3 Hierarchical Digital Materials.....	20
4.4 Part Fabrication.....	23
4.5 Application: 3D SOIC-Pitch Circuit	24
4.6 Other Potential Applications	28
5 Digital Assembly of Digital Materials.....	29
5.1 Machine Design.....	30
5.2 Assembler Head Design.....	33
5.3 Discussion.....	39
6 Conclusion.....	41
References.....	44

Abstract

This thesis develops the use of additive assembly of press-fit digital materials as a new rapid-prototyping process. Digital materials consist of a finite set of parts that have discrete connections and occupy discrete space. Part geometries were designed and fabricated at different scales from different materials, including hierarchical voxels which connect across different scales. All parts were designed to be vertically assembled with top and bottom connections. Digital materials are discussed as a new way for building physically reconfigurable, multi-material 3D structures. The parts were designed with press-fit connectors to build reversible assemblies to take full advantage of reuse and recycling. This document starts by describing some current technologies in the fields of rapid-prototyping and personal fabrication. The concept for a press-fit digital materials is defined and explained. Many part designs are documented, including conductor and insulator parts for SOIC-pitch 3D circuits and hierarchical assemblies. This thesis concludes with the design and concept for assembly machine to automate building functional digital materials.

1 Introduction

Current rapid-prototyping machines are fundamentally continuous or analog processes. Although many fabrication machines are digitally controlled, these machines continuously cut or add material to make parts. This section illustrates a brief history of digitally controlled, analog manufacturing tools and personal fabrication technologies.

1.1 CNC Fabrication

NC (numerically controlled) machine tools have enhanced design and fabrication methods since the 1940's. The early machines were manual lathes and mills that were retrofitted with servo or stepper motors to automate motion control for increased production speeds, accuracy, and part complexity. One of the first NC machines was a programmable milling machine developed by MIT's Servomechanisms Laboratory in the early 1950's [Pease 1952]. This machine filled an entire room and cost approximate 360k USD (about 2.6 million in 2005 USD). The electronic control system consisted of 250 vacuum tubes, 175 relays, and many moving parts. CNC motion control systems now cost a fraction of this cost. Motor drivers can be built at a cost less than 5 USD in parts and can be controlled by microprocessors that cost less than 1 USD per quantities of one. Similar to early computers, fabrication machines were once extremely expensive, difficult to use, and filled large spaces. Desktop fabrication machines are now ubiquitous, affordable, and easy to use.

1.2 Personal Fabrication

Rapid-prototyping machines have traditionally been large, expensive, and complicated machines which only expert engineers and machinists used to make things. This is changing; more and more people are designing and building smaller, cheaper, and more user-friendly machines. Many recent CNC (computer numerically controlled) machines use CAD/CAM (computer aided design/computer aided manufacturing) work flows which make manufacturing almost as easy as pressing “print.” Many people now have desktop milling machines for making custom engravings, jewelery, or even circuit boards. Desktop 3D printers are also more accessible and affordable. 3D printers are used to rapidly produce physical 3D models on demand. A digital description file used in these machining processes can be created using many different 2D or 3D design software packages and subsequently shared on the Internet to be downloaded and reproduced wherever a prototyping machine exists. This has and will continue to revolutionize the way people design and make things.

1.3 Machines that Make

During the fall of 2009, I began working on a project to design and build a small CNC circuit board milling machine. I created an open source, do-it-yourself CNC machine toolkit, which consisted of a small machine having a 2”x3”x1.25” (X,Y,Z) working area. The total size of the machine was about 8³ inches. The custom parts were all made from 0.5” thick MDO plywood. The part description files could be downloaded as a DXF or G-code file and milled on a larger 3-axis CNC milling machine. I named this machine the MTM A-Z. The machine consists of 26 custom parts labeled A through Z. The motors, bearings, shafts, and other hardware can be purchased from a few online vendors using a bill of materials. Several other students and researchers in the area were working on DIY desktop rapid-prototyping machines. This growing body of machines are documented on the website: mtm.cba.mit.edu. One machine consists of a 3-axis machine and fabrication toolkit that fits in a box with an interchangeable toolhead for milling, lasercutting, vinylcutting, and 3D printing. Another MIT graduate student, designed and constructed CNC desktop milling machine with a cost less than 100 USD, and there are several others designs evolving. Open source hardware for machine tools will allow people to customize their own machines for specific functional needs or preferences, to size the machine within their price range, and to be constructed with locally available materials.

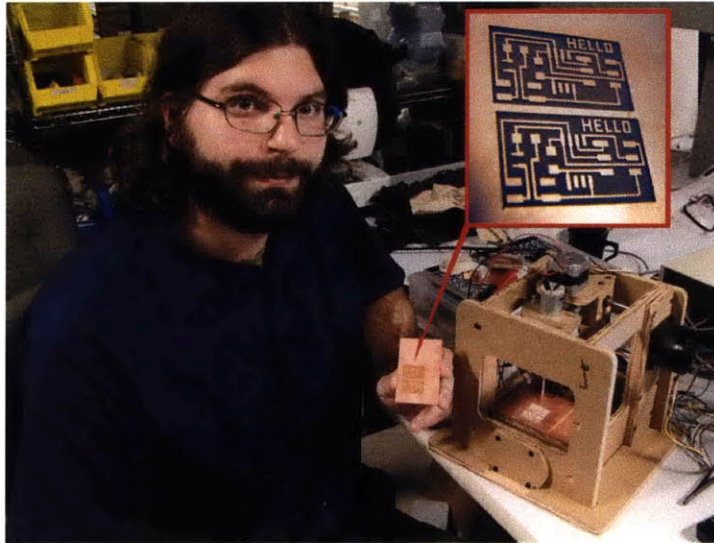

Figure 1.3a

This is a mini CNC machine I designed to mill circuit boards from FR-1 stock. With a computer, Internet connection, and this machine, printed circuit board files can be downloaded and produced on the desktop.

The goal of the Machines that Make project is to develop personalized personal fabrication machines, which are tailored for users needs and more affordable than commercially available machines and built from local materials and supplies. Building these machines can also be used as a educational exercise in teaching CNC technology to aspiring engineers and makers. Designing and making machines that can be produced in a Fab Lab is the initial steps toward creating Fab Lab 2.0: a fabrication laboratory where all the machines are custom machines largely produced by a lab of commercial equipment. This will make labs and equipment more accessible for some parts of the world where commercial equipment may be too expensive and/or too difficult to import into the area. Fab lab 2.0 will cost a fraction of the price of a commercial lab, and the lab will be able to produce the parts and machines for future labs with new capabilities.

Designing and developing our own machines has initialized the process of rethinking and re-questioning manufacturing technologies. For example, how can machines additively assemble multiple materials to make functional structures rather than simply cutting or extruding material into representational objects? And why is current 3D printing technology limited a few materials which are limited in functionality? How can we make more complex additive assembly processes which is reversible in order to take full advantage of reusability? These questions are the foundations and motivation for this work in additive assembly of functional digital materials.

2 Background

Additive assembly of digital materials describes a new way for rapid-prototyping which is different from traditional continuous fabrication processes. *Digital fabrication* has been used as a term to describe analog machines which are digitally controlled; these machines continuously cut or add material to make parts. This section explains the difference between additive and subtractive machining processes and analog and digital fabrication.

2.1 Additive vs. Subtractive

Rapid-prototyping machines can be broken into two categories: additive and subtractive fabrication machines. Additive fabrication machines typically build models by extruding a material in a liquid state; then, the material is hardened after exiting the print head. For example, FDM (fused deposition modeling), extrudes a molten plastic, which cools after leaving the extruder head. Stereolithography is a process which extrudes a bead of UV curable photopolymer resin which is cured by a laser after it is deposited in place. Z corporation 3D printers build models by depositing layers of powder and controlled drops of binder to build a 3D part layer by layer.

Subtractive machining processes start with a stock material and remove material in a controlled way to create the desired part. Milling machines are a common tool used for subtractive machining; these machines use a high-speed spindle with milling tools to cut wood, plastic, steel, and many other machinable materials. CNC milling machines are most commonly 3-axis machines, but more complex shapes can be sculpted by milling machines attached to robot arms with six degrees of freedom. Some CNC milling machines fit on a desktop while others fill large amounts of space in industrial shops.

Rapid-prototyping machines allow people to build extremely precise parts which cannot be achieved by hand and the design software allows many complex modifications to be made on demand. Some industries use CNC technology to simply speed up production. Other makers, such as artists or architects, use CNC technology to build more complex shapes which would otherwise be impossible to fabricate. CNC technology also enables tool-makers to customize and make new jigs and machines to augment construction or have new capabilities.

2.2 Analog vs. Digital

Although both additive and subtractive rapid-prototyping processes are becoming more accessible and affordable, they are still largely material dependent processes, and the cutting or building process is irreversible. CNC milling machines continuously subtract material, and 3D printers continuously add material. Although, both of these types of machines are digitally controlled, they are fundamentally continuous (analog) fabrication processes.

A digital material consists of a finite number of building blocks which have discrete joints and occupy discrete space. A comparison between LEGO blocks to masonry can illustrate the difference between digital and analog construction. The male/female pin joints on the top and bottom of a LEGO block are discrete connections, which either make or do not make a connection to another block. By contrast, a masonry construction is a continuous (analog) material. While the masonry brick is a discrete unit, the fluid state of the mortar allow one brick to be placed on top of another brick in an infinite number of positions [Popescu 15]. Because the joint is continuous and not discrete, masonry construction is analog. LEGO construction uses a finite number of blocks with discrete joints; therefore, a LEGO structure is completely digital.

3 Digital Materials

The word *digital* comes from the word *digit* which is derived from the Latin word, *digitus*, meaning finger. The connection between digital and finger comes from fingers often used for discrete counting. The word digital is most notably used in the context of communication and computing, but digital materials are physically digital structures. A digital material is made up of a discrete number of parts which have a finite number of connections. These digital building blocks are referred to as *voxels*: 3D pixels.

3.1 Error-Reducing Materials

Digital parts are error correcting and self aligning which allow them to be assembled into structures with higher accuracy than the placement accuracy of the assembling mechanism. These parts occupy discrete space and form their own 3D lattice by self-aligning. For example, LEGO blocks utilize a discrete pin joint has a tapered feature which allows one block to register to another and reduce placement errors below a maximum placement error threshold. To illustrate error correction in LEGO blocks, let's say a human child has approximately 0.2 mm of hand placement accuracy, but the self-aligning feature of the LEGO connectors correct for placement errors to allow a child to assemble structures within tolerances of approximately five microns [Hiller and Lipson 2008]. This is analogous to the field of digital information technology; Claude Shannon showed that near perfect communication could be achieved over a noisy channel as long as the noise was below a certain threshold which can be calculated [Bruen and Forcinito 2005]. Similarly, the building blocks of a

physical structure can self-align in order to reduce placement errors and create near perfect physical structures.

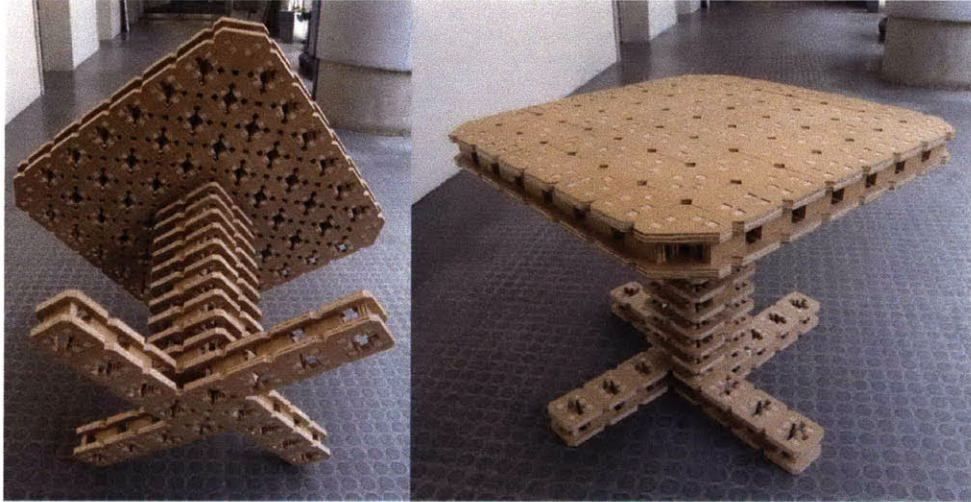

Figure 3.1a

Digital parts were designed to make 3D space frame structures. This is an example of reconfigurable furniture as a table assembled from a finite set of parts. This piece was assembled by a human with a rubber mallet, demonstrating that the error correcting parts allow structures to self-align into a precise 3D coordinate system. The parts are the material, fastener, and assembly fixture with no adhesives for reversible assembly process.

3.2 Multiple Materials

Structures which are created from multiple material types allow explicit control over design and optimization parameters [Hiller and Lipson 2009c]. Digital materials can be constructed out of rigid, flexible, transparent, opaque, conductors, insulators, semiconductors, lightweight, or heavy materials. Multiple material structures could be used to build microfluidics structures or assemblies made up of active and passive electronics, optics, and/or parts with specific mechanical properties. Digital materials allow any or all of these materials can be assembled within the same assembly. A multiple material digital assembly can be built by one multi-material digital assembler machine. Multi-material 3D printers already exist [Objet 2010], but the parts are not reversible and the material palette is limited to some rigid photopolymers and elastomers. Objet machines deposit drops of material which are cured in place. The drops of material are discrete, but they still bond to another drop in infinite possible ways. Two of the primary functional requirements for a completely digital materials, as described in this paper, are discrete joints and reversible bonds between parts.

Materials made from many different types of materials are expensive and time consuming to break down for recycling. Therefore, building a material from multiple materials with reversible bonds between parts would allow a multi-material product to be completely recycling and reused [Hiller and Lipson 2009b].

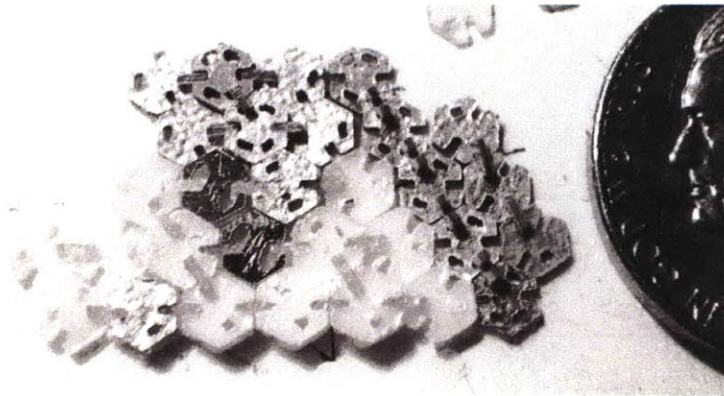

Figure 3.2a

A press-fit assembly of ABS plastic, acetate, mica laminate and copper hexagonal parts connected by press fit joints

3.3 Reversible

Digital technology has most notably revolutionized information technology and computing, but construction and fabrication are still largely continuous (analog) processes. This results in parts for products being one-off designs which cannot easily be reused; when these parts become obsolete they most likely end up in landfills. Trash is an analog concept; digital materials take full advantage of reuse and recycling.

A digital material is made up of parts with reversible connections between all of the building blocks that make up the material. The materials will be assembled by a digital assembler machine; the assembler will also be a disassembler. This machine will have a head for disassembly and sorting. Another possibility is to use a separate machine to take on the tasks of disassembling, sorting, and delivering parts back to the assembler machine. The reversible connections allow the exact same parts to be reused and reconfigured without waste or degrading the quality of the material. For example, physically digital conductors and insulators can make reconfigurable 3D circuits. Physically digital active electronics also opens up the possibility of having discrete transistors with reversible connections to make devices such as reconfigurable ASICs or other devices which can be reprogrammed by changing the physical configuration of the parts making up a device.

Jonathan Hiller, a graduate student at the Computation Synthesis Laboratory at Cornell University, has constructed a voxel assembling machine and the resulting models were shown to be reversible [Hiller and Lipson 2009b]. This machine

assembles structures made up of many spherical voxels and deposits an adhesive to bind the spheres together. The assemblies were shown to be reversible and reused by dissolving the adhesive binder and separating the parts by material type for reuse. Another option we are exploring is to use a press-fit interference connection rather than adhesives for connecting parts. Press-fit connectors eliminate the use of adhesive binder. However, the geometry required for press fit parts adds complexity to part handling and part fabrication. Spheres are easy to manufacture and handle at many scales from many materials, and they self align when placed on a lattice.

One common press-fit part design is a slotted connection which mates with another slot to create an interference fit connection. This slot acts as a clamp which flexes when its mate part interferes with the space the other part occupies. This clamping mechanism is essentially a flexure, which can be designed and tuned to exert a specific force while also providing a snap-lock release mechanism for ease of reversibility. The flexing part can be used for an interlocking mechanisms which can give a press-fit connection more strength than the material itself. In other words, when two press fit parts are put in maximum tension, the material will break before the connection separates. This type of connection uses the principal of *elastic averaging*, which means the connection is overconstrained by making contact at many points over a large area [Slocum 353]. Elastic averaging is a nondeterministic connection, but the load capacity and stiffness are not limited. On the other hand, a kinematic design is deterministic but the stiffness and load capacity is limited [Slocum 354].

A release mechanism added to a flexure will provide controlled reversibility. This allows one part to be disconnected from the structure without putting significant force on the rest of the assembly. The force required to disassemble should be less than the force required to assembly when a release mechanism is designed into a part.

4 Press-Fit

A press-fit connection is a joint which holds together by friction or micro bonding between surfaces. Press-fit connections are also referred to as interference fit, because one part is essentially interfering with the space of another. A press fit connection can be generally analyzed using the following equations:

$$f=kx \text{ (where } x \text{ is the slot width)}$$

$$S=x^2 \text{ (S is contact surface area)}$$

$$k=YS \text{ (Y is the material's Young modulus)}$$

$$f=Ys^3 \text{ (f is the force required to pull apart two slotted press-fit parts)}$$

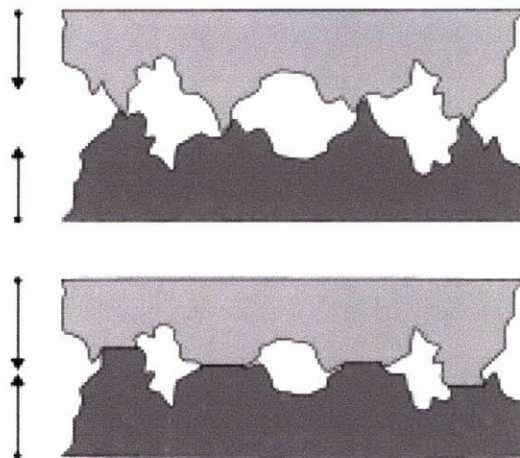

Figure 4.2a

“Applying a high clamping force causes the asperities, the peaks and valleys that populate the part surface on the submicron level, to mesh together” [Slocum 95].

Force, area, friction, and surface finish as well as material and fabrication tolerances greatly affect the quality and repeatability of a press-fit connection. The image above shows the asperity of two surfaces and how normal force increases the contact area. Even two mirror finish surfaces look similar to this at the nanometer length scale. Force between two surfaces can greatly increase amount of surface area actually in contact.

Cold welding is essentially the term for adherence between two similar metals which have no oxidation on the surface. In a cold welded connection between two materials, both materials being ductile aids in this bond as there is plastic deformation occurs when the materials are pushed together. This force can be caused by

mechanically deforming the pieces, or force exerted from a flexure during interference fitting. This principal of elastic averaging is very dependent on the accuracy of the manufacturing process used to make the parts. “If an elastically averaged system is properly designed, fabricated, and preloaded, the average contact stress will be low, high points will wear themselves in with use, and errors will be averaged out by elastic deformation” [Slocum 353]. Applying force between two surfaces could be done by cooling a metal during the assembly process, and subsequently heating it to expand to form a tight bond or a cold weld. “Parts that are flat enough can be permanently cold welded together by carefully finishing the mating surfaces, cleaning the parts putting them together with dry alcohol between the surfaces, placing the assembly in a vacuum chamber, and pumping out the air. When done properly, the surfaces fuse and the assembly behaves like a single piece” [Slocum 95]. However, it must be noted that “practically all materials will break under numerous repetitions of a stress that is not as great as the stress required to produce immediate rupture” [Young and Budynas 46]. Therefore, reversibility will be impossible in some cases or fatigue will limit the number of reusable connections of a press fit part can make.

4.1 GIK

GIK¹, *The Great Invention Kit*, is a press-fit construction kit similar to LEGO. The great things about GIK parts is the simplicity of the slotted press fit connection design, and the simple 2.5D shapes make GIK easy to fabricate at many scales and from many different materials.

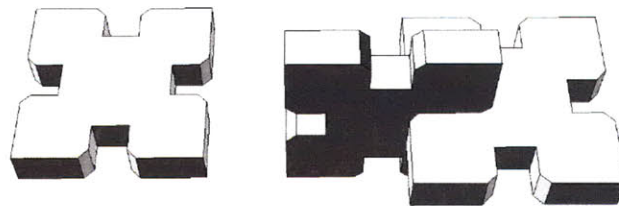

Figure 4.1a
press-fit GIK parts

George Popescu analysed [Popescu 19] the amount of force required to connect and disconnect GIK parts. This work showed that the force to disconnect the parts was constant after approximately 10 previous connections, meaning the connection is reliably reversible. Another interesting highlight of this work showed that the amount of force required to add or remove GIK parts simultaneously grows faster than linear with respect to the number of GIK parts [Popescu 18].

¹ GIK is a press-fit construction kit invented by Eli and Grace Gershenfeld, known as *Grace's Invention Kit* and the *Great Invention Kit*.

4.2 Part Design

Many part designs were designed and explored for use in additive assembly of functional digital materials. The basic functional requirements for the parts shapes are:

- parts must be 2.5D geometry
- parts must be vertically assembled
- finished assemblies of parts must be able to achieve near one hundred percent density
- press-fit connection between parts

2.5D parts are desired to simplify part fabrication process. Vertical assembly will simplify the automated build process. The assembly process should be similar to current 3D printing machine; a print/assembly head will build structures from the top-down. One hundred percent density is desirable to fill maximum amount of space with minimal voids in a structure; however, density can then be reduced as desired. Press-fit connections between parts are used for reversibility and to avoid using an adhesive binder. These parts eliminate the need for fasteners or assembly fixture; the parts are the fasteners and fixture for assembly.

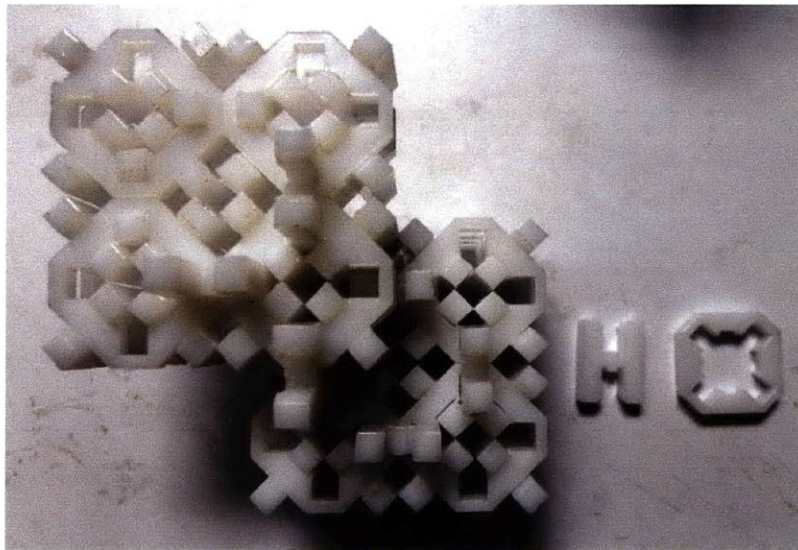

Figure 4.2a
concept for variation of GIK parts using “O” and “H” shaped connectors

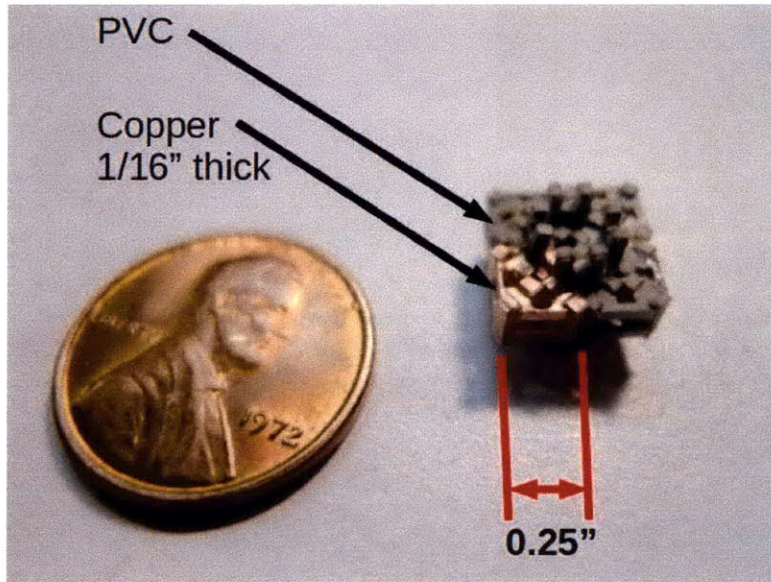

Figure 4.2b
assembly of conductor and insulator parts

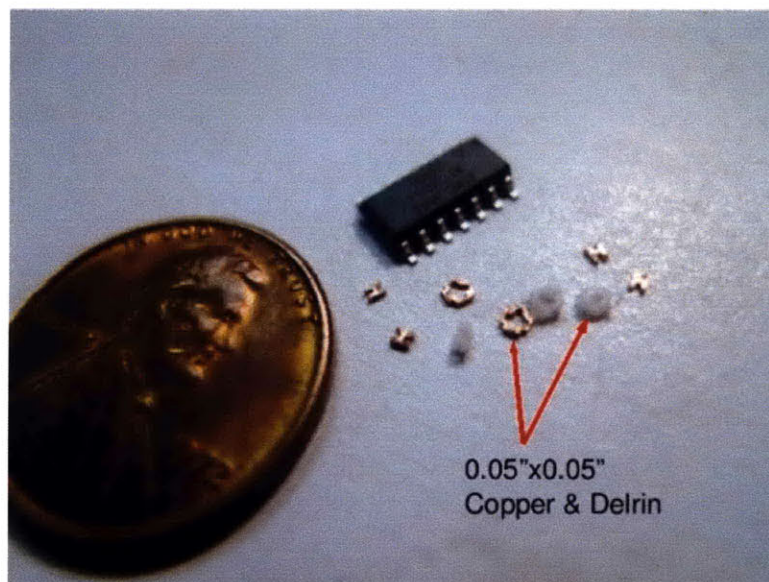

Figure 4.2c
50 mil conductor and insulator parts

Hexagonal parts were designed to achieve one hundred percent density and vertically assembled 3D interconnected structures. The “C” shaped connectors shown below are preferred to make a smooth surface finish and to avoid electrically connecting more than two layers when these parts are used for conductors.

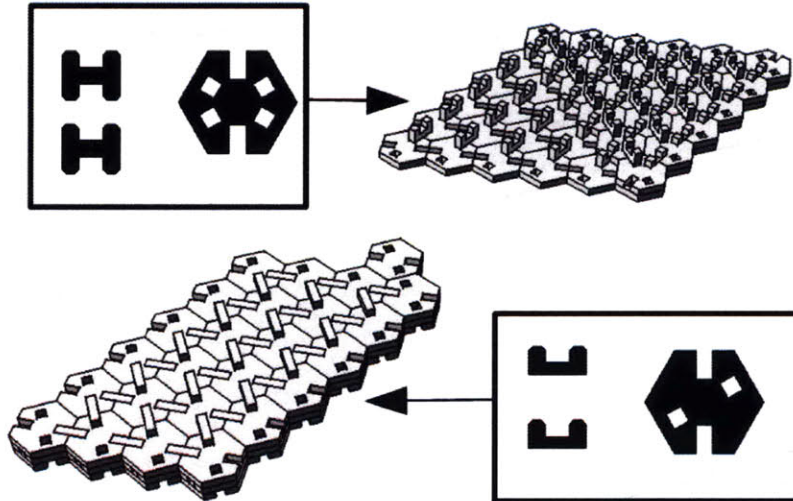

Figure 4.2d
hexagonal and with “H” and “C” shaped connectors

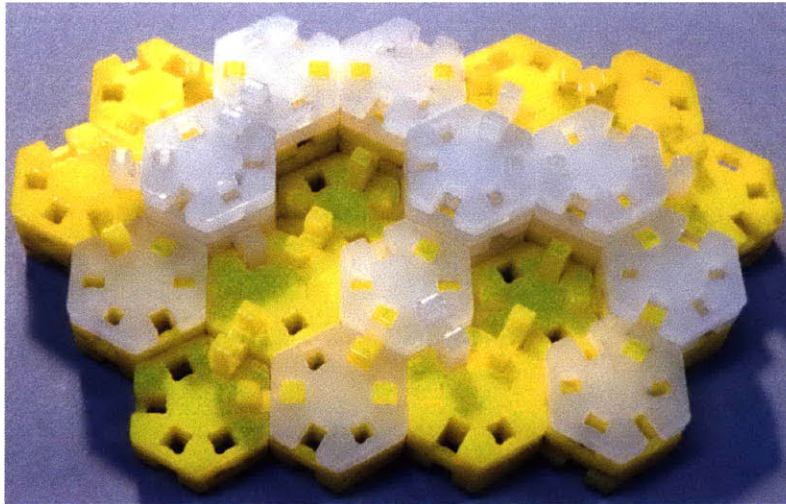

Figure 4.2e
Press-fit Hexagon GIK parts cut from 1/8" thick acrylic with a laser cutter

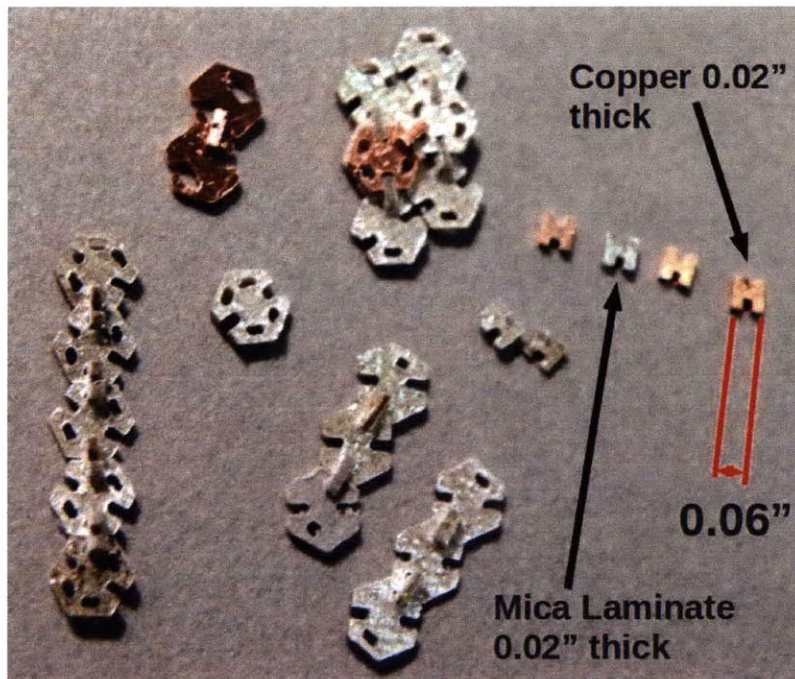

Figure 4.2f
Mica laminate and copper parts machined on a CNC mill with 1/64" carbide endmill

4.3 Hierarchical Digital Materials

A hierarchical digital material consists of parts which can connect to self similar parts. A variable voxel size essentially allows the blocks within an assembly to arbitrarily change feature size where needed. The difference between constant voxel size and variable voxel size is similar to the difference between a constant bit rate and variable bit rate in sound or video encoding in computing. MP3 music files, for example, use variable bit rate to reduce the size of the file without noticeable quality loss; the bit rate is higher at times in a song where this complexity is needed to express more information and lower during silences, when there is less information. Similarly, a hierarchical digital material can use larger blocks for long structural spans, and smaller blocks to increase density and reduce feature size where more tightly packed blocks are needed throughout a structure.

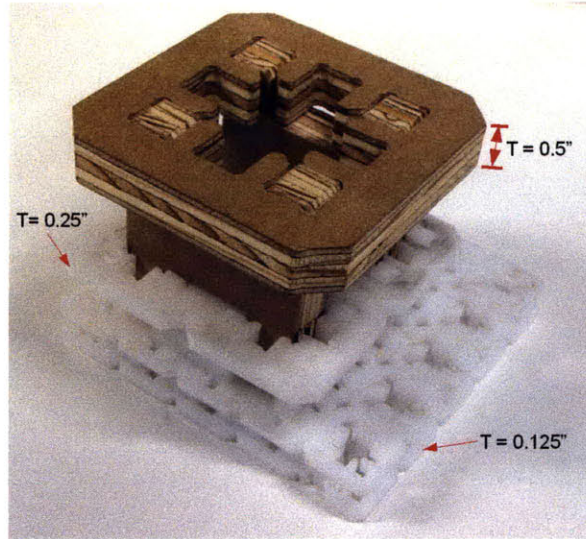
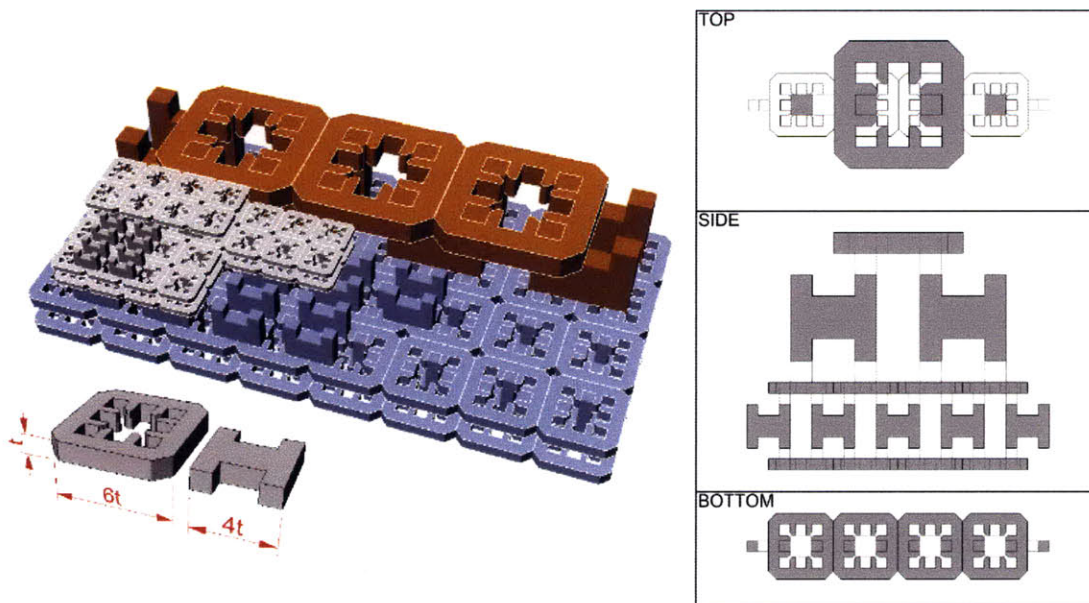

Figure 4.3a
self-similar parts constructed and assembled showing hierarchy

Hierarchical digital materials consist of parts which can interconnect to other self-similar parts. The parts shown can achieve this connection through vertical assembly. Hierarchical digital material construction set can be fabricated at many scales and hierarchical parts can interconnect to self similar parts. In other words, the voxel size within the same structure can range from arbitrarily small to arbitrarily large, limited only by the ability to fabricate parts at a given scale.

Figure 4.3b
Diagram of hierarchical parts showing scalability and vertical interconnect between self-similar parts



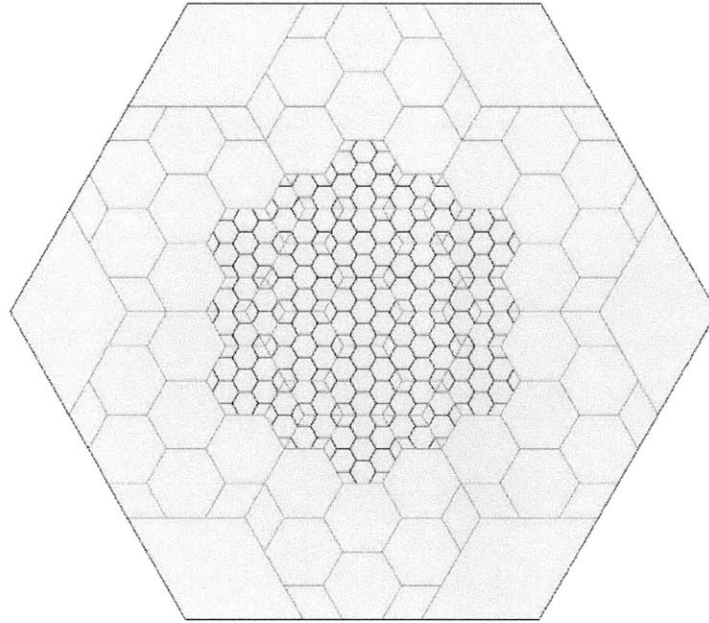

Figure 4.3c
2D tiling of hexagons
“Hierarchical structures or fractal structures result from the iterative procedures that involve rescaling” [Lord, Alan, and Ranganathan, 77].

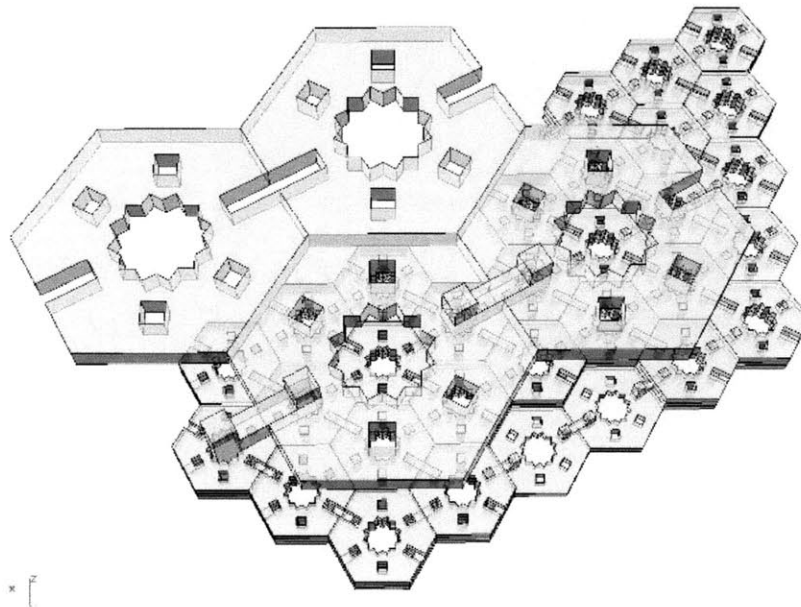

Figure 4.3d
3D model of hierarchical hexagonal press-fit structure

4.4 Part Fabrication

Many different materials were used to make prototype parts. The chart below (figure 4.4a) documents the materials, thicknesses and machines used for making parts with general quality of results and comments. Quality of results is to note the general success of the process, 5 being high quality and 1 being poor results. Multiple settings for speeds and feed rates were used; these settings are not listed in this chart, but a basic starting point for cutting speeds and feeds have been thoroughly documented [Oberg, Jones, and Franklyn 975].

material	thickness	machine	tool	quality (1-5)	comments
copper	0.0625"	CNC mill	1/32" endmill	4	large tool radii on inside corners
copper	0.0312"	CNC mill	1/32" endmill	3	large tool radii on inside corners
copper	0.02"	CNC mill	1/64" endmill	3	difficult to secure part to machine
aluminum	0.02"	CNC mill	1/64" endmill	3	galling and difficult part fixturing
acrylic	0.0312"	laser cutter	N/A	2	tapered cut
delrin	0.0312"	laser cutter	N/A	2	tapered cut
Mica-laminate	0.02"	CNC mill	1/64" endmill	4	small parts tend to delaminate
ABS plastic	0.02"	laser cutter	N/A	3	tapered cut
ABS plastic	0.03"	3D print	N/A	4	texture on part surface and brittle
PVC	0.0312"	CNC mill	1/32" endmill	4	rough surface finish after cutting
Acetate	0.02"	laser cutter	N/A	3	tapered cut
fish paper	0.02"	CNC mill	1/64" endmill	3	rough surface finish after cutting

Figure 4.4a

Chart documenting materials, machines, and quality of results of part fabrication methods

In general, laser cutting was not adequate for parts smaller than 0.02" (500 micron) in thickness. Laser cut parts had a significantly tapered cut edge. However, alternating the orientation of vertical face of each part in the assembly relative to how it was cut on the laser resulted in the taper to be somewhat parallel to the taper of its neighboring part which worked as an interlocking feature.

Milling was the best process for making metal parts as the cuts were vertical and, when speeds and feeds were properly set, the surface finish was adequate for making a solid press-fit connection. Further prototyping will be improved by using a micro mill with ~2 micron placement accuracy and smaller (~25 micron) tool diameters to achieve smaller scale (250 micron) voxels with precision surface finish to achieve smaller parts and more reliable press-fit connections.

These fabrication methods were used for prototyping test parts, but batch production of parts will be necessary to make digital materials feasible. Molding, extrusion, pultrusion, and stamping are potential processes to be used for batch production of digital materials.

4.5 Application: 3D SOIC-Pitch Circuit

Digital materials can be used to create functional structures. Conductor and insulator parts have been designed for press fit SOIC-pitch circuit boards with 3D electrical interconnect. These parts can be hierarchical to change size within a structure or tune traces or for current levels. The figure 4.5a shows a structure made of three sizes of press fit parts which can be vertically assembled to allow SOIC-pitch electrical components to connect to any exterior face of the structure. Electronic components could potentially be placed inside voids within a structure and press-fit parts could be assembled around the components to act as the device's mechanical structure as well as the protective case for the electronics.

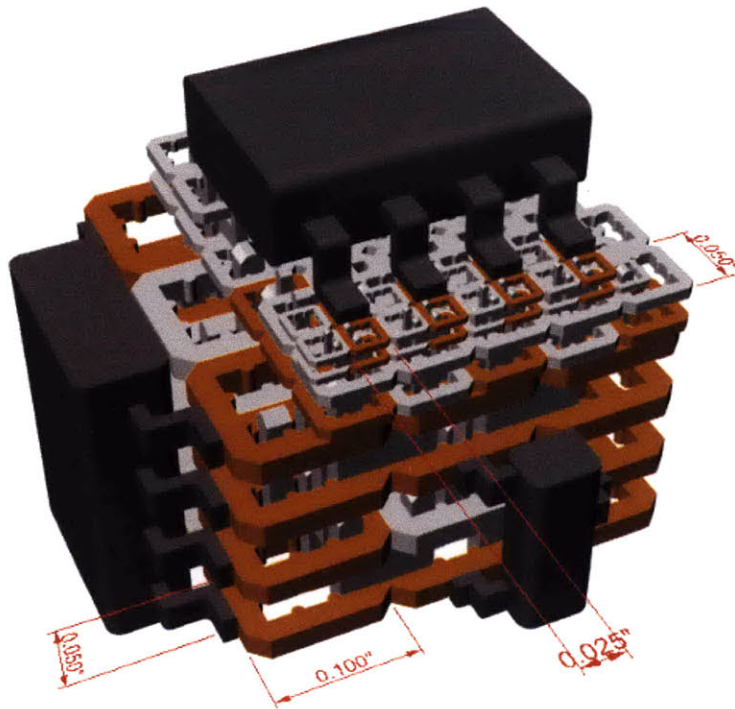
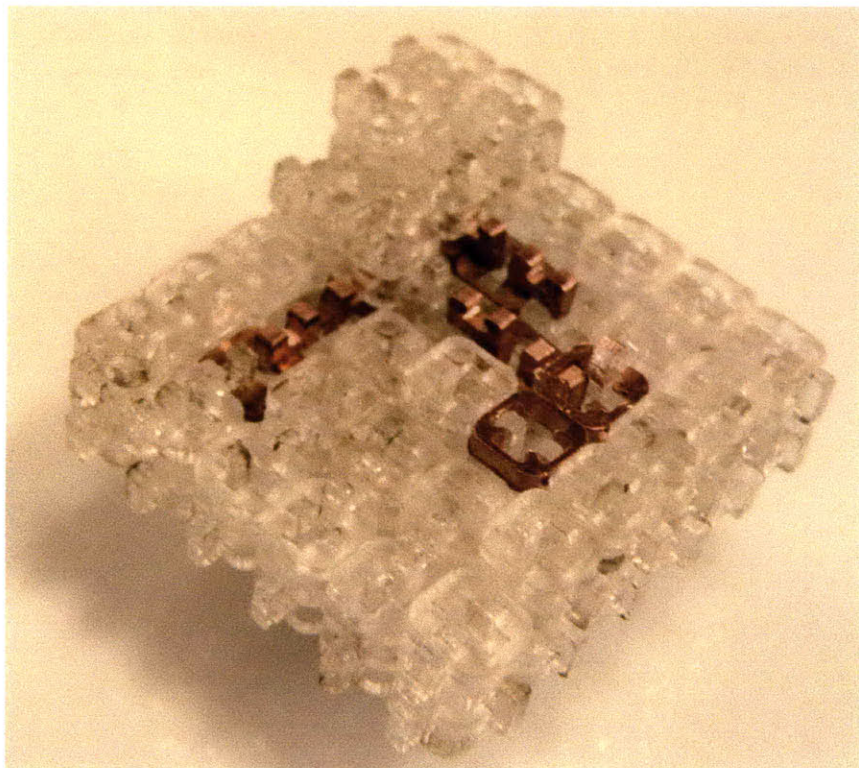

Figure 4.5a
Rendering of a hierarchical press fit conductors and insulators used to connect 3D SOIC-pitch components



*Figure 4.5b
Copper and Acrylic press-fit parts*



*Figure 4.5c
Digital assembly of acrylic and copper parts*

Insulation-displacement connectors use a “V” shaped press fit connection which strip insulation barrier wires as they are inserted into the connector, and the connector remove oxidation at boundary layer between the copper contacts on the wire and connector. When these connectors are made properly they form a gas tight, interference connection which is highly reliable. The concept for these press-fit circuits uses the same idea: when the connection is properly designed and constructed, it will allow air tight bonding to occur to make a solderless electrical connection.

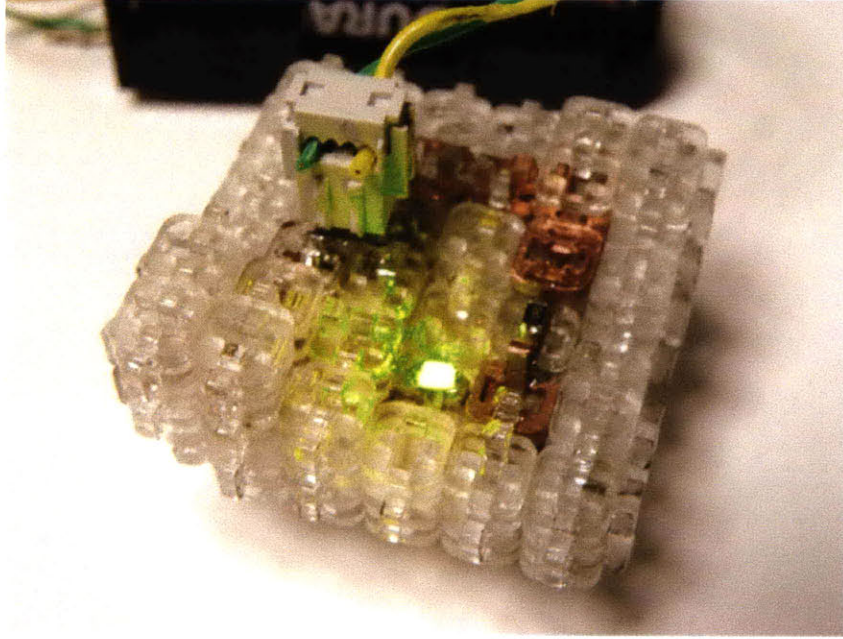

Figure 4.5d

Press-fit 3D circuit (LED, resistor, and header) using copper conductors and acrylic insulators



Figure 4.5e

CT scan of a press-fit circuit

A CT scan (figure 4.5e) of this structure revealed that some of the acrylic parts melted during the soldering process, so a heat resistant insulator material was used for a second prototype. The image 4.2f shows mica/paper laminate and copper parts. The mica laminate is stable up to 932 degrees F, so these parts will withstand the soldering process without deforming.

Figure 4.5f
Conceptual rendering of hexagonal press fit circuit for SOIC-pitch parts

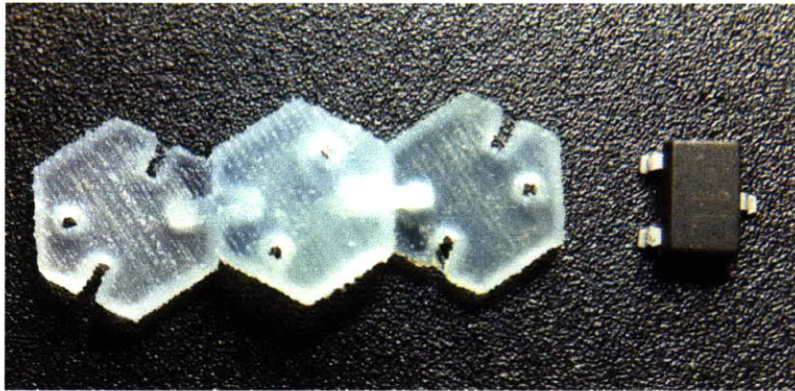

Figure 4.5g
ABS plastic parts made with a 3D printer

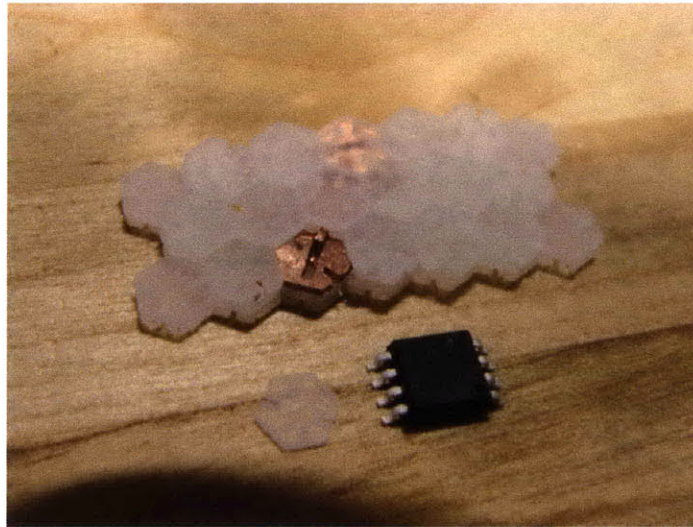

Figure 4.5h
Press fit assembly of ABS plastic and copper parts

4.6 Other Potential Applications

Hierarchical, functional digital materials allow tuning of groups of voxels to explicitly control the mechanical characteristics of a material. Combining rigid and flexible voxels in 3D halftone patterns can be used to create an auxetic material, meaning the material has a negative Poisson ratio [Hiller and Lipson 2009a]. These materials essentially become wider when they are put in tension as opposed to a rubbery material which becomes thinner when stretched. For this reason, auxetic materials are sometimes referred to as “anti-rubber.” A rubber material put in tension maintains its volume, while a material with a negative Poisson ratio changes volume when loads are applied. Auxetic structures are useful for creating impact resistant structures and many other applications. Digital manufacturing of digital materials adds more potential control over the design and fabrication process.

Part assemblies consisting of flexible and rigid materials could also be used to create functional springs or flexure bearings. Optical devices could be created with variable opacity or reflection angle to change light quality or explicitly control light direction. Digital materials for optics could be used to manipulate refraction angles build lenses or devices with other unique properties such as a negative refractive index, which have been constructed from metamaterials. Digital materials could also be useful for 3D microfluidic structures which require intricate networks of capillaries. Many of these functions could be built into the same model using by the same machine using a multi-material digital assembler.

Further research could also lead to the development of physically reconfigurable active electronics by creating press-fit active semiconductor parts. George Popescu created a press-fit, GIK diode ohmic junction using copper, N-doped silicon, and lead parts [Popescu 15]. This proves that active electronics can be built with digital materials. There have been other developments in physically reconfigurable 3D computers and electronic devices as a strategy to decentralize hardware for ease of upgradeability and physically reconfigurable options for computers and other electronics [Ward, Pratt and Nguyen 1997].

5 Digital Assembly of Digital Materials

A digital material is made up of discrete parts which are the fasteners and the indexing fixture for assembly. Rather than having many complex shapes, fixtures, and jigs, which sometimes require expert assemblers and documentation, digital materials reduce the unique part count to simplify building instructions. Alexander Graham Bell, known primarily as the inventor of the telephone, also invented the space frame in order to build large kites around the year 1900 [Gabriel 28]. He used a tetrahedral structure that had few unique parts and tuned for stiffness. In 1907 Bell designed a 28m tall tower using another variation of his space frame structural system. The tower weighed only 5 tons and was erected by unskilled laborers in a mere 10 days [Gabriel 28]. These space frame structures had many of the same properties of a digital materials; the structures were made of discrete parts with discrete joints. The space frames built by Bell had few unique parts and simplified assembly instructions.

An instruction set to assemble a digital material can be reduced to a simplified string of symbols. Digitally coded assembly instructions are translated to machine movement to place a voxel. Then, the code will instruct the machine to either place or not place another voxel of a specified size and material at a location relative to the previous part and continue this process to build a digital material. The assembler machine would only need to make discrete movements which are synchronized to place parts or the correct type in the correct order. The digital assembler machine builds parts as a top-down assembly process similar to current 3D printers, and the assembler will create models layer by layer.

5.1 Machine Design

Digital materials built of voxels smaller than about 2mm are difficult, time consuming, and not feasible to assemble by hand. A 3D printer/assembler will be needed to automate the build process and assemble the materials. The concept for the machine is that it will be a top down assembler that builds structures more precise than the placement accuracy of the machine itself. This is different from “bottom-up fabrication which exploits the intrinsic properties of atoms and molecules to direct their self organization” [Rothermund 2006]. The machine should also have error detection and error correction to build near perfect structures using a closed loop assembly process. The assembler machine works by pressing parts into place; if a part is placed outside of the correction range of the material, the part is discarded and a new part is resent to ensure a perfect building process. This is similar to TCP and CRC protocols used on the Internet; the receiver can check if there is an error during a transmission and request a resend.

An automated assembler for functional digital materials is being developed. The basic concept for the machine is a voxel placing apparatus which can add or subtract voxels at high speeds. Similar to a pick-and-place, one building head will dispense and place different types and sizes of parts. Current pick-and-place and chip shooter technology can place parts at speeds up to 15 Hz. If we take, for example, a voxel size of 0.025 inches, one cubic inch would consist of 40^3 or 64,000 voxels. If the machine were to assemble parts at 15 per second, it would take about 70 minutes to build one cubic inch of material made up of 25 mil voxels. This is comparable to build times of current 3D printing technology, but increasing speed of the assembler could be obtained by using higher feedstock flow rates, by adding more print heads for parallel assembling, and by utilizing hierarchical parts to reduce resolution in areas where small feature size is not needed.

The machine design consists of a basic three-axis machine bed; an assembling head with part feeders will supply a palette of different parts to the assembler. The target goal for this machine will be to assemble and disassemble conductors and insulators into working SOIC-pitch circuits with 3D electrical interconnect. The images (5.1c and 5.2b) below show concept renderings of a assembler and details of the part assembling mechanism. This machine will have multiple part feeders and part pusher turret for automated assembly of multiple material types, scales, and shapes.

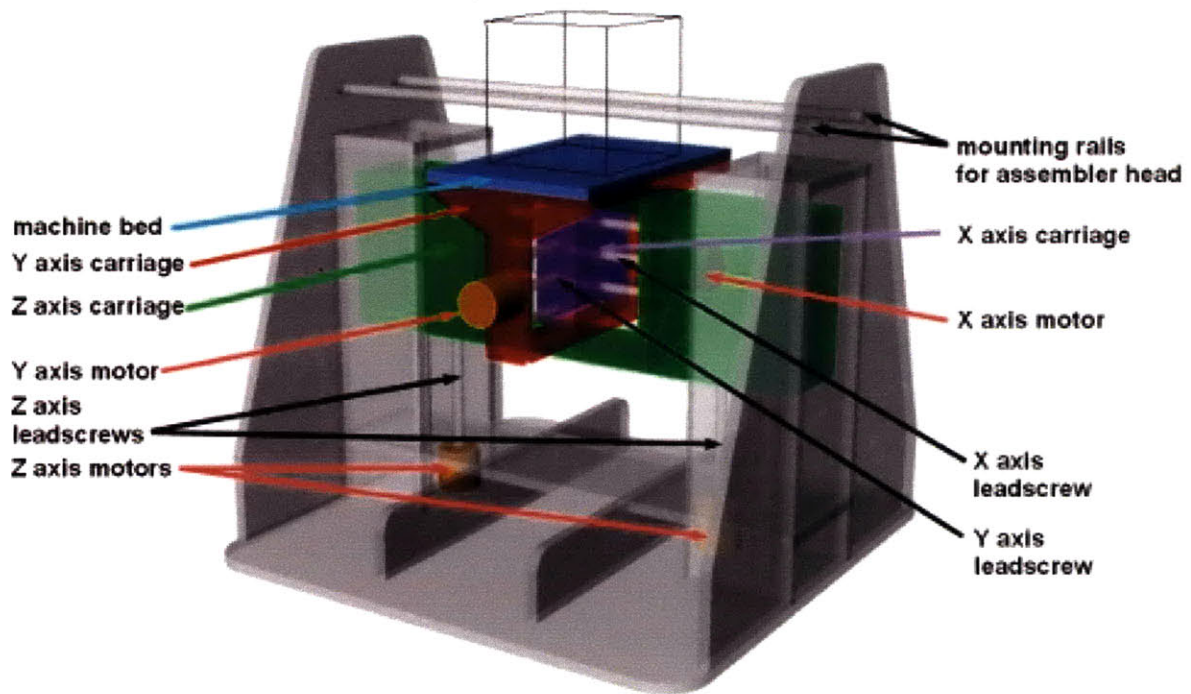
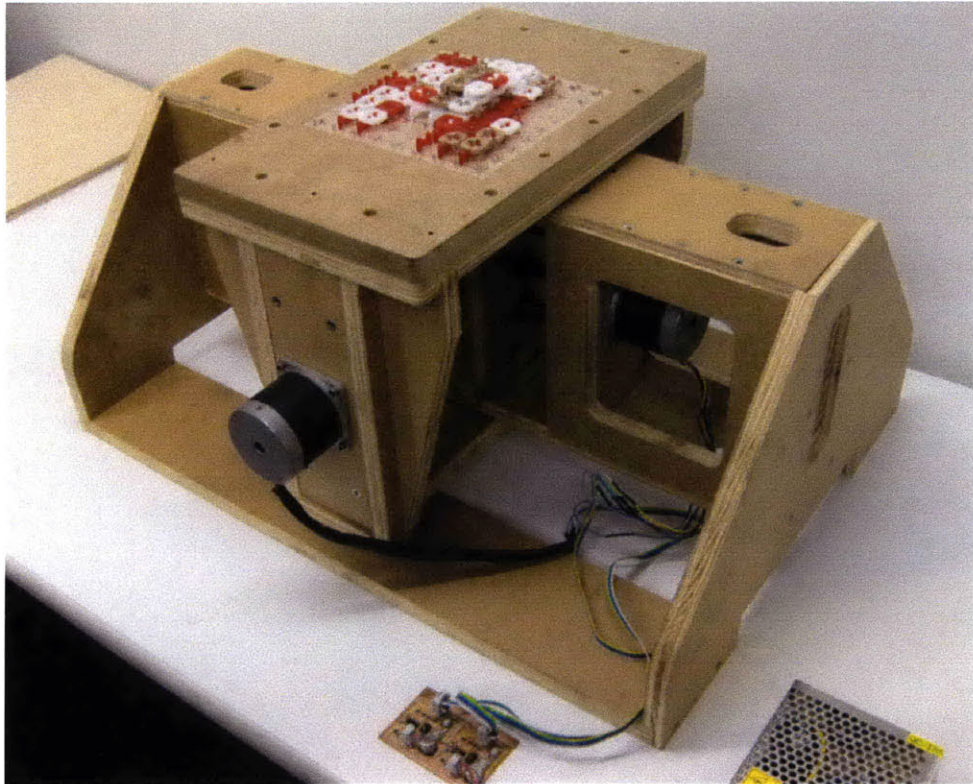

Figure 5.1a
rendering of a 3-axis CNC machine bed
this concept was used to eliminate moving the assembler head



*Figure 5.1b
Bench-level prototype of a 2axis machine bed*

This platform was constructed using open loop control with stepper motors and lead screws for linear actuation. The first prototype was built with only X and Y moving bed to test and debug 2D assembly before moving to 3D assembling. The image above shows the machine before printer head and part feeders were constructed. This machine used 1/2"-8 dual start acme lead screws directly connected to unipolar NEMA 23 stepper motors. The motors step 200 full steps per revolution, so coupled to screws with a pitch of 1/4" gives a resolution of 0.25/200 inches (0.00125") per full step. Initial testing would be done with 1/8" voxels, so a placement of ± 0.001 inch would be high enough resolution for voxels at this size. Microstepping would not be needed. Simple stepper motor drivers were built using two 8 bit AVR microcontrollers. Each board has two buttons to jog the machine manually or accept step and direction input from another processor. The basic strategy is to start simple and design and build in complexity as needed.

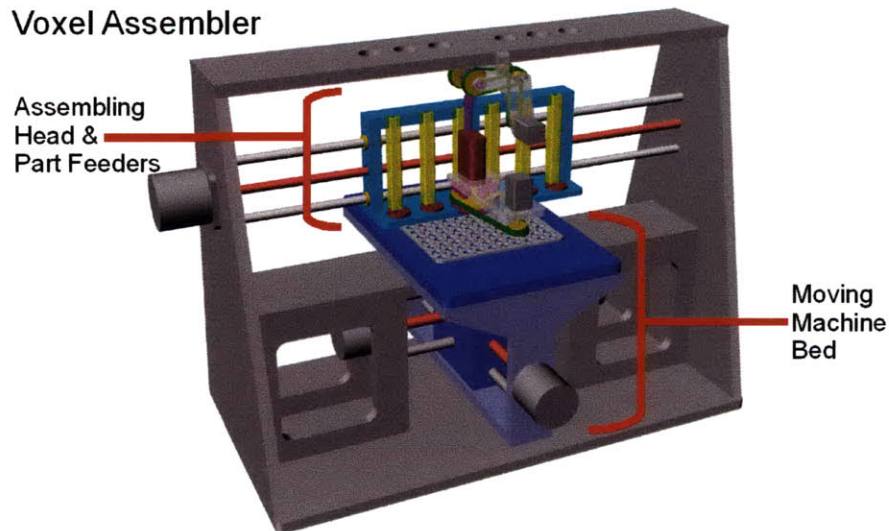

Figure 5.1c
Schematic Diagram of digital assembler with 2 axis machine bed and part feeder print head

5.2 Assembler Head Design

The basic concept for the machine print head is a voxel placing mechanism to press fit parts together. An initial rendering (figure 5.2a) shows an initial concept rendering of a part pushing mechanism with two different parts being fed into each side of the head. The first step will be to press fit one type of part in two dimensions. Then, next steps will include adding 3D machine bed movement and multiple part type dispensers as well as a reversible head for removing and sorting parts for reuse. The target speed for automated assembling will be ~1-10 Hz. Initial voxel sizes were designed at 0.025" thickness for compatibility with SOIC-pitch electronic components. (figure 4.5h)

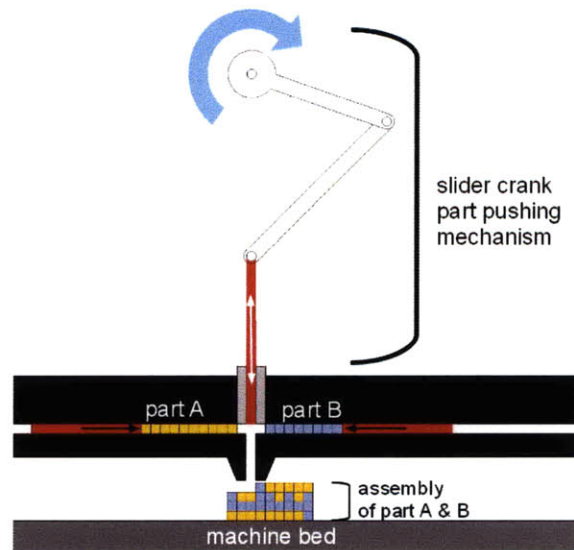

Figure 5.2a

Schematic rendering of a basic part feeder and assembling mechanism to assemble parts

The first prototype head was built to test a simple part placing mechanism. This preliminary design consists of a basic three axis machine bed and an assembling head with continuous feeders supplying conductor and insulator parts in order to build 3D PCBs. The schematic diagram (figure 5.2c) shows that the machine uses one part pushing mechanism; a turret tool changer is rotated into position below the part pushing mechanism as the corresponding part feeder is moving into place. This eliminates the complexity of moving the assembling head.

3D Print Process	~Min. Feature Size	~Min. Layer Thickness	~Build Time per 1x1x1" (25.4 ³ mm)
Stereolithography	0.003" (0.0762 mm)	.00158" (0.40132mm)	6 hrs
FDM	0.007" (0.1778mm)	.007" (0.1778mm)	1 hr
Thermoplastic Extrusion	0.080" (2.032mm)	0.012" (0.3048mm)	1 hr

Digital Assembler	Part Placing Speed	Voxel Size	Layer Thickness	Build Time per 1 ³ (25.4 ³ mm)	number of voxels per 1 ³ inch
1.0	1 Hz	0.25" (6.35 mm)	0.025" (0.635mm)	10.7 min	640
2.0	10 Hz	0.025" (0.635mm)	0.0025" (0.0635mm)	17.8 hrs	640k
3.0	100 Hz	0.025" (0.635mm)	0.0025" (0.0635mm)	1.7 hrs	640k
4.0	1000 Hz	0.0025" (63.5 microns)	0.00025" (6.35 microns)	7.4 days	640 x 10 ⁶

Figure 5.2b

This chart shows some approximate build times and feature size for three types of 3D printers to build a 1"x1"x1" cube. The second chart shows digital assembler build times for different assembly speeds and voxel sizes. Digital assembly will initially be slower than 3D printing, but the advantages of digital materials will be building multi-material, hierarchical, and reversible assemblies.

A prototype print head was built without automated actuators and a continuous part feeder for testing and visualization (figure 5.2d). The test head was constructed with a hexagonally shaped part pushing mechanism (figure 5.2f) and a part loading mechanism. (figure 5.2d) The concept for this mechanism is best described as being somewhere between a stapler, sewing machine, semi automatic firearm, and a 3d printer. The machine loads parts from a clip and presses them into place using a rotary to linear mechanism, such as a slider crank or cam. The part is then pushed into place while the moving machine bed locates the assembly within range of the part self aligning into the 3D lattice. Parts were loaded one by one and the part loading and placing mechanisms were actuated by hand to assemble some hexagonal parts on top of an existing single layer of parts assembled by a human with tweezers. (figures 5.2e and 5.2f)

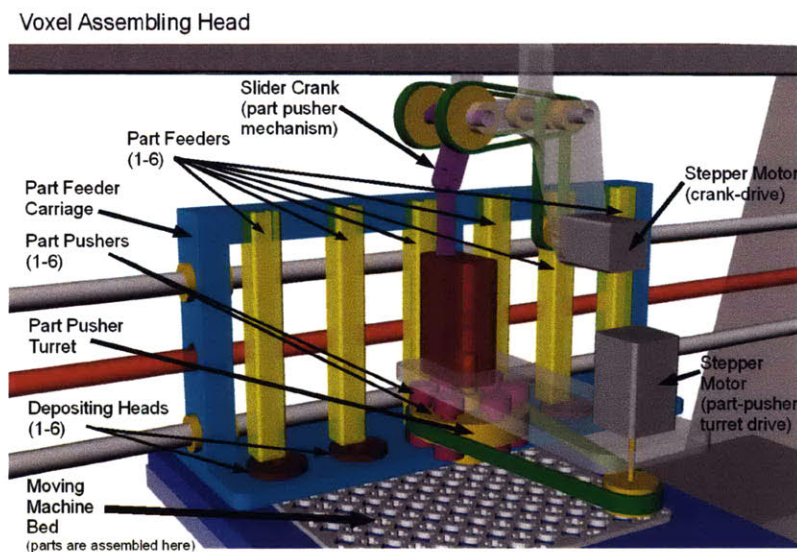

Figure 5.2c
detail of print head concept, showing multiple part feeders, tool changing turret, and part pushing mechanisms

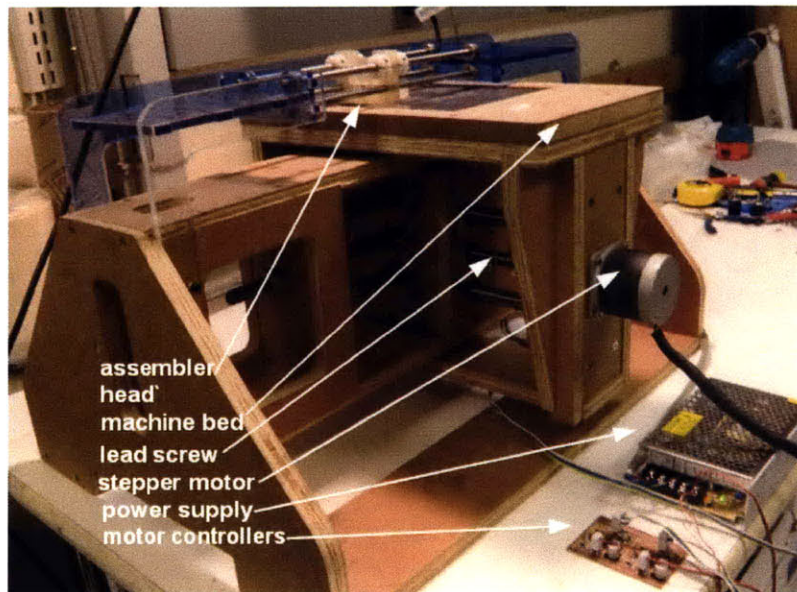

Figure 5.2d
bench-level prototype of CNC machine bed and hand actuated assembler head

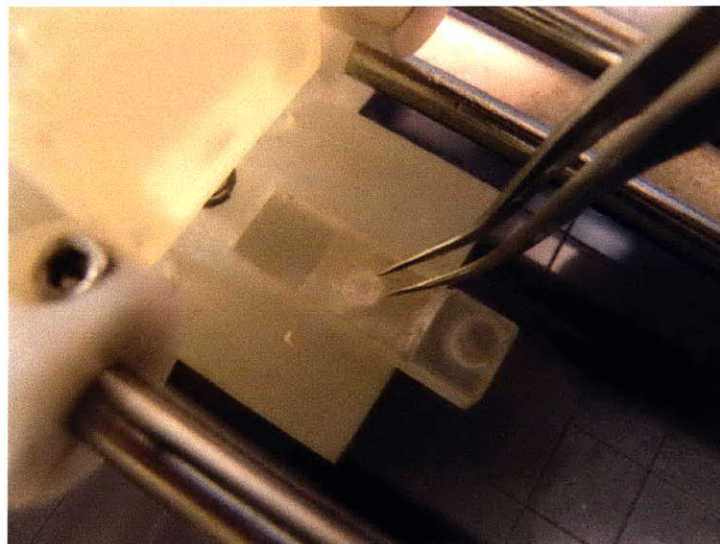

Figure 5.2e
detail of a part being inserted into the print head part loading mechanism with tweezers

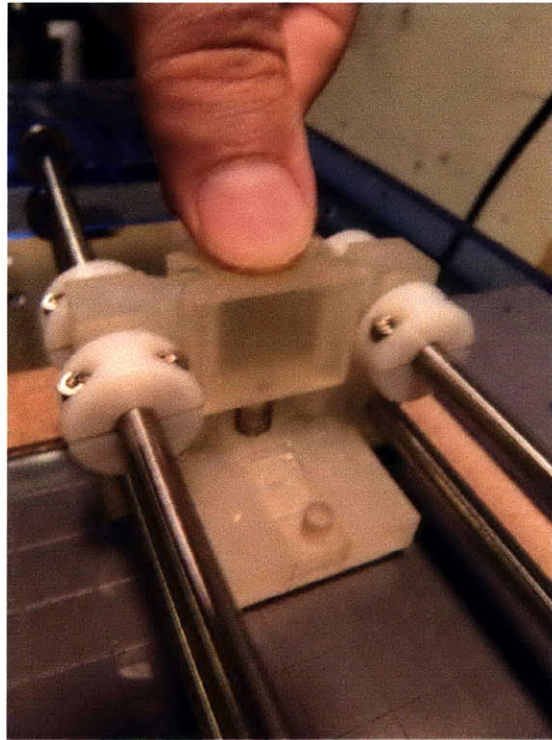

Figure 5.2f
part pushing mechanism being actuated by hand

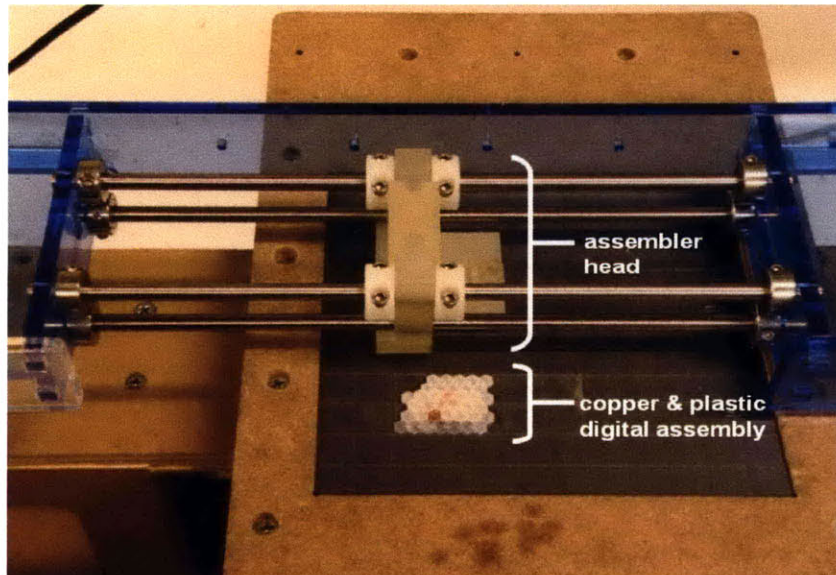
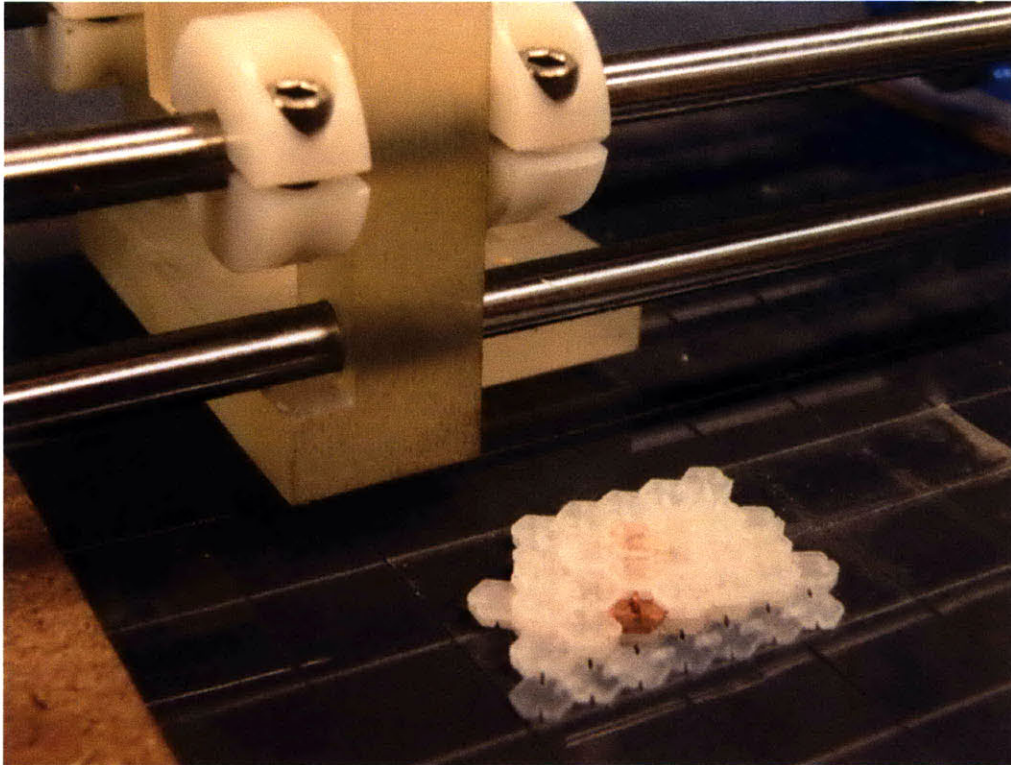

Figure 5.2g
machine bed, part assembling head, and assembly of parts



*Figure 5.2h
assembler head prototype and assembly of plastic and copper parts*

5.3 Discussion

This section describes risks and countermeasures for further research and development of the material and machine for additive assembly of digital materials.

Many mechanical parts such as bearings or shafts may not be possible to construct from digital materials as moving parts require very accurate surface finish or geometry where a finite voxel size may not be adequate to produce these features. A continuous manufacturing process may need to be used to develop these special parts. However, a continuous part could be designed to connect to a digital structure. An example of this could be a linear plain bearing embedded in a digital assembly. Digital construction may not provide the adequate surface finish and hardness for the inside surface of a bearing, but a conventional bearing could have connectors for mating with a digital material to combine analog and digital fabrication.

Another challenge will be to make press-fit structures from flexible materials. For example, a slotted press-fit connection is difficult or impossible with soft, rubber-like materials. New geometries and connection types will be needed to be developed for flexible materials. Post heating or adhesives could be also used to bind flexible parts together, but this will possibly result in an irreversible assembly.

Wear and tear will result from repeated interference connections between parts. This would either result in discarding or recycling parts after degradation. Another option is to develop a treatment processes and/or new materials which are more resistant to wear. For example, a coating could be applied to a surface contact region of a voxel, and this coating could be reapplied after some number of connections to restore the bond strength.

Support material to build hollow structures could be difficult with parts that have one hundred percent density as there might be no hole for support material to be removed after the build process. A support material should consist of parts which do not form bonds but allow enough support and have enough compressive strength for a vertical construction process. As with current 3D printing, a hole could be left to allow support material to be removed. A second solution is to remove the support material before the model is finalized, or the model could be built in sections and the support material removed before the sections are joined.

Contact resistance could be a problem when building a digital material using conductors for an electrical or thermal conduction. In order to decrease contact resistance, the parts could be built with interference fit to reduce the gap size between contacts. A tight bond would also work to remove oxidation as the parts are joined. A conductive grease could also be applied to each joint to augment conduction or a sealant applied post assembly to prevent oxidation. However, adding grease could limit conductivity and also require part cleaning and treatment before each use.

6 Conclusion

Four stages on the road map from current fabrication technology to self assembling materials are:

1. computers control machines to make things
2. machines that can make machines
3. codes in digital materials (external assembler)
4. programs in digital materials (self assembly)

We are currently between stages two and three; this stage is the shift from digitally controlled analog fabrication to digitally controlled digital fabrication. Stage four is the development of materials which can self-assemble into functional structures.

The key concepts developed for additive assembly of digital materials in this thesis were:

- Hexagonal 2.5D press-fit parts for near one hundred percent dense structures
- Hierarchical digital materials to span length scales
- Press-fit conductor and Insulator parts for 3D circuits
- Digital assembler machine design and concept

Further research will be conducted for the development of batch fabrication processes and part size reduction to achieve state-of the art 3D assembled parts. An assembling mechanism for digital materials was developed as only a concept testing platform. Future work will involve developing a machine to be completely automated with a head constructed to rapidly assemble and disassemble structures at high speeds. When we achieve more accurate and consistent parts, specific testing on tensile, compressive, and torsional strength will be done to predict results and tune and optimize mechanical properties of the parts and assemblies.

The immediate next steps for this research will be a new version of the digital assembler will be developed to assemble and disassemble parts at a target speed of 10 Hz. The challenge will be handling parts and delivering parts to the head without jamming and detecting and correcting errors in the assembly process. The application for parts will be additive assembly of 3D electronics. Research will continue with part shapes, materials types, and smaller parts. Semiconductor materials will be explored and developed to enable digital assemblies of active and passive electronic structures.

Another compelling future application for digital materials is a partially self-replicating machine which could be constructed with digital materials and assemble many of its own electrical and mechanical parts. The machine will be physically reconfigurable in size, shape, and function. The image below shows a diagram of a 3-axis CNC machine chassis constructed of digital materials with conventional motors,

rails, and bearings. Preloading between each press-fit joint allows the possibility of building ridged and light space-frame structures to achieve stiffness and reduce vibration. The number of unique parts can be minimized with digital materials, and the machine will be physically reconfigurable.

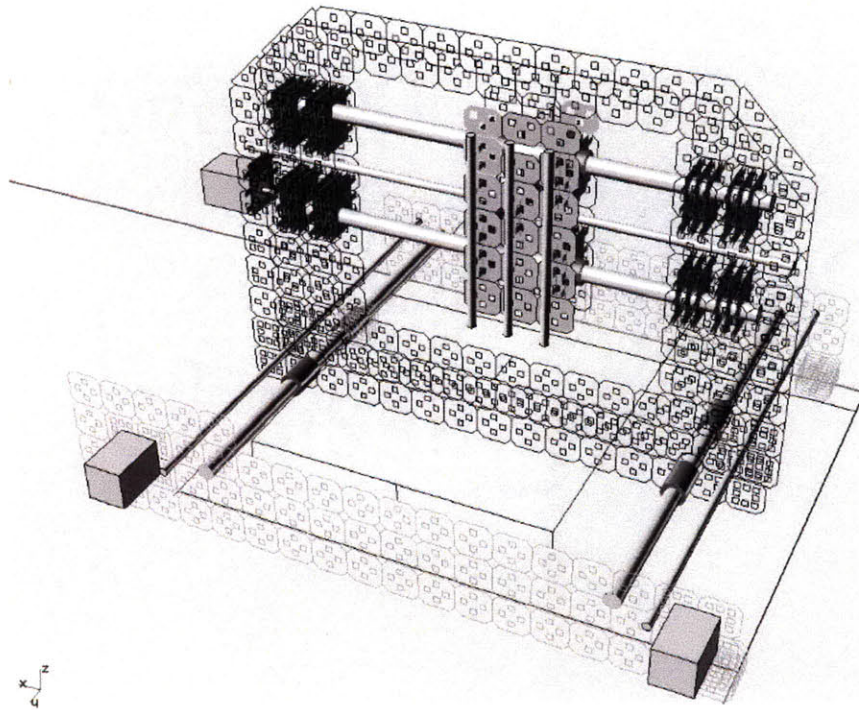

Figure 6a
Schematic diagram of 3Axis CNC machine made of press-fit parts

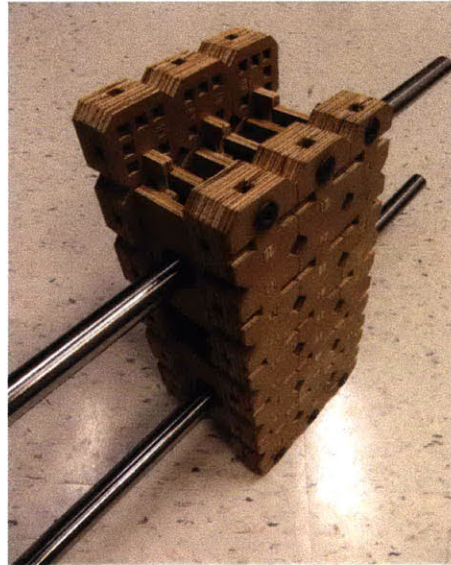

Figure 6b
bench-level prototype of a press fit assembly with linear bearings and shafts
this is a prototype for a linear machine component

Digital materials allow explicit optimization of functional structures. Each part shape and material type can be tuned for the optimal shape, strength, density, and stiffness needed. Error reducing and correcting features of digital materials allow for repeatably constructing perfect structures. Similar to the shift from analog to digital technology in telecommunications and computing, the design and assembly of physical structures will be revolutionized by shifting from analog fabrication to digitally assembled digital materials.

Physically reconfigurable and reusable products barely exist in the current manufacturing paradigm. Digital materials suggest a novel reconfigurable construction kit with potential immediate applications in rapid-prototyping of functional 3D parts. Digital materials allow physically reconfiguration and reusable and recyclable devices as opposed to multi-material products and materials, which typically discarded into landfills. Hierarchical digital materials allow voxel size to be variable within the same assembly to span length scales. Self-similar part designs at which connect across different scales gives a wider range of applications by allowing assemblies with variable feature sizes and voxel density. Ultimately, digital assembly of digital materials eliminates many of the constraints and limitations of traditional analog manufacturing and rapid-prototyping processes by enabling rapid prototyping of multi-material, hierarchical, reversible, error-reducing, and reconfigurable structures.

References

Bruen, Aiden A., Forcinito, Mario A. Cryptography, Information Theory, and Error-Correction : A Handbook for the 21st Century. Hoboken, N.J. Wiley-Interscience. 2005

Griffith, Saul. Growing Machines. PhD Thesis. Massachusetts Institute of Technology. September 2004.

Griffith, Saul, Goldwater, Dan, Jacobson, Joe. Self-replication from Random Parts. Nature, Vol 437. September 29 2005.

Hiller, J., Lipson, H. 2009a. Design and Analysis of Digital Materials for Physical 3D Voxel Printing, rapid-prototyping Journal, Vol. 15, No. 2, pp. 137-149.

Hiller, J., Lipson, H. 2009b. Fully Recyclable Multi-Material Printing. Solid Freeform Fabrication Symposium (SFF'09), August 3-5 2009, Austin, TX, USA.

Hiller, J., Lipson, H. 2009c Multi Material Topological Optimization of Structures and Mechanism, Genetic and Evolutionary Computation Conference (GECCO'09), pp. 1521-1528.

Hiller J., Lipson H., 2008. Tunable Digital Material Properties for 3D Voxel Printers, Proceedings of the 19th Solid Freeform Fabrication Symposium, Austin TX, August 2008.

Gabriel, François J., Beyond the Cube: The Architecture of Space Frames and Polyhedra. New York. John Wiley & Sons, INC. 1997.

Lord, Eric A., Mackay, Alan L., and Ranganathan S., New Geometries for New Materials. Cambridge. Cambridge University Press. 2006.

Oberg, Erik, Jones, Franklyn D., Horton, Holbrook L., and Ryffel, Henry H. Machinery's Handbook 28th Edition. New York. Industrial Press. 2008.

Objet 3D Printing Materials. 2010. <http://www.objet.com/Materials/> (1 Aug 2020).

Pease, William. An Automatic Machine Tool. Scientific American. 1952, September: 101-115.

Popescu, George A. 2007. Digital Materials for Digital Fabrication. Thesis (S.M.)-- Massachusetts Institute of Technology, School of Architecture and Planning, Program in Media Arts and Sciences. 2007.

Popescu, George A., Patrik Kuntzer, Neil Gershenfed. Digital Materials for Digital Printing. Digital Fabrication. Denver, CO September 2006.

Rothermund, Paul W. K., 2006. Folding DNA to Create Nanoscale Shapes and Patterns. Nature. Vol 440, 16 March 2006, pp 297-302.

Schroeder, Manfred R. Number Theory in Science and Communication. The Netherlands. Springer. 2006.

Slocum, Alexander H. Precision Machine Design. Dearborn, Michigan. Society of Manufacturing Engineers. 1992.

Young, Warren C., and Budynas, Richard G., Roark's Formulas for Stress and Strain. New York. McGraw-Hill. 2002.

Ward, Stephen A. Pratt, Gill A. Nguyen, John, Pezaris, S. Margolus, Norman. 1997. Three-Dimensional Interconnect Having Modules with Vertical Top and Bottom Connectors. U.S. Patent 5,691,885, filed October 14, 1994, and issued November 25, 1997.