



# ADS-B BENEFITS TO GENERAL AVIATION AND BARRIERS TO IMPLEMENTATION

Fabrice Kunzi and R. John Hansman

Report No. ICAT-2011-6  
May 2011

MIT International Center for Air Transportation (ICAT)  
Department of Aeronautics & Astronautics  
Massachusetts Institute of Technology  
Cambridge, MA 02139 USA



## **ABSTRACT**

Automatic Dependent Surveillance - Broadcast (ADS-B) will be the basis of the future surveillance system in the US. To achieve benefit from ADS-B, aircraft have to be equipped with ADS-B avionics across all stakeholders. General Aviation (GA) comprises over 96% of the active aircraft fleet in the US but average yearly utilization for GA aircraft is 21 times lower than that of commercial aircraft. Since many benefits from ADS-B depend on aircraft utilization, concern exists that ADS-B does not provide enough user benefit to GA, possibly resulting in delayed acceptance and aircraft equipage with ADS-B avionics.

One way of providing user benefits and thus increasing incentives for GA users to equip with ADS-B is to create and implement ADS-B applications that are of high value to those operators. ADS-B Surveillance in non-RADAR airspace and ADS-B based Traffic Situation Awareness (TSA) are identified as two applications that are expected to provide significant benefit to GA. Both applications are evaluated and possible barriers to the delivery of benefit are identified.

In order to identify where TSA would be most beneficial, ten years' worth of NTSB mid-air collision reports were reviewed. Ten years of ASRS and NMACS near mid-air collision (MAC) reports were also reviewed. The analysis revealed that aircraft are most likely to encounter each other in the airport vicinity – specifically in the pattern (59% of MACs). Current Traffic Awareness systems are not reliable in that environment due to insufficient surveillance data quality. Surveillance data from ADS-B, however, has much higher resolution. Therefore, ADS-B based traffic alerting systems are expected to be capable of providing reliable alerting in such environments and would thus pose a significant incentive for GA to equip with ADS-B.

An analysis of the current availability of low altitude surveillance over the continental United States was conducted in order to identify where ADS-B Low Altitude Surveillance would be beneficial. Providing low altitude surveillance has the potential to improve efficiency during IFR conditions. 27 towered airports with RADAR floors of more than 500ft have been identified. ADS-B surveillance in those locations would create a significant benefit locally. Non-towered airports without low altitude surveillance are more common (806 total). ADS-B surveillance to such airports has the potential to increase airport acceptance rates in Instrument Flight weather and thus providing benefit to GA.

However, in addition to providing surveillance, additional ATC procedures need to be developed to take advantage of such ADS-B surveillance. The new procedures would allow ATC to remain in radio communication with aircraft operating at non-towered airports, preventing the application of inefficient procedural control.

## **ACKNOWLEDGMENTS**

I would like to express my sincere thanks to Prof. Hansman for his tireless support and instruction. His knowledge and insight have taught me much and have made me a better engineer.

I wish to thank Brooklyn Lowry for her support volunteering her editorial and journalistic skills.

My deepest thanks go to my wife and best friend Alyssa who has been my greatest supporter and motivator. Her caring and selfless attitude has let me work long nights to finish my work while still finding rest at home.

## TABLE OF CONTENTS

Chapter 1	Introduction and Motivation.....	13
Chapter 2	Overview of ADS-B System Architecture.....	17
2.1	Aircraft Capability – Aircraft Avionics.....	20
2.1.1	ADS-B Out Mandate.....	20
2.2	ADS-B Ground Infrastructure.....	21
2.3	ADS-B Operating Procedures.....	23
2.3.1	Adoption of Existing, RADAR Based Procedures.....	23
2.3.2	Introduction of New, ADS-B Specific Procedures.....	24
2.4	ADS-B Applications.....	24
2.4.1	ADS-B Out Applications.....	25
2.4.2	Data Link Applications: FIS-B and TIS-B.....	26
2.4.3	ADS-B In Applications.....	28
Chapter 3	ADS-B Avionics Architectures for General Aviation.....	31
3.1	Navigation Unit.....	32
3.1.1	GPS Integrity.....	34
3.1.2	GPS Accuracy.....	36
3.1.3	Common GPS systems used in GA.....	38
3.2	ADS-B Transceiver.....	38
3.2.1	Historical ADS-B Transceivers.....	39
3.3	Cockpit Displays for ADS-B In.....	40
3.4	Antennae.....	41
3.5	Upgrade Paths From Transponder Based Surveillance Systems.....	41
3.6	Certification of ADS-B Avionics Installations.....	43
Chapter 4	Identifying ADS-B User Benefits to General Aviation.....	45
4.1	ADS-B Benefit Categories.....	47
4.1.1	Improved Safety.....	47
4.1.2	Improved Efficiency.....	48

4.1.3	Reduced Infrastructure and Maintenance Cost .....	48
4.2	Previous Work on GA User Benefits .....	50
4.2.1	Lester User Survey and User Benefit Mapping (Lester 2007).....	50
4.2.2	AIWP Benefit/Application Ranking (FAA 2010).....	52
4.3	High User Benefit Applications for GA.....	53
4.3.1	Safety Improvements From Data Link Applications.....	54
4.3.2	Applications That Improve Safety .....	54
4.3.3	Applications That Increase Efficiency.....	55
4.4	Conclusion.....	57
Chapter 5	Identification of High Benefit Environments For Traffic Situation Awareness Applications.....	59
5.1	Mid-Air Collision Analysis: NTSB Accident Reports .....	59
5.1.1	Mid-Air Collisions Reported in the Airport Pattern.....	61
5.1.2	Mid-Air Collisions Reported in the Airport Vicinity .....	62
5.1.3	Mid-Air Collisions Reported Away from the Airport.....	63
5.2	Near Mid-Air Collision Analysis: ASRS and NMACS Databases.....	64
5.3	Conclusion: ADS-B Based Traffic Situation Awareness Brings Major Benefit to GA ..	68
Chapter 6	Identification of High Benefit Locations For ADS-B Low Altitude Surveillance .....	71
6.1	Analysis of Existing RADAR Coverage Over the Contiguous United States .....	73
6.2	Identification of Airports Where ADS-B Surveillance Could Provide Benefit .....	76
6.3	ADS-B Efficiency Benefits at Towered Airports .....	77
6.4	ADS-B Efficiency Benefits at Non-Towered Airports .....	79
6.4.1	Non-Towered Airports With RADAR Floors in Excess of 1500ft AGL .....	80
6.5	Conclusion.....	82
Chapter 7	Summary and Conclusion.....	83
Appendix A	Full List of Required ADS-B Message Elements.....	85
Appendix B	Detailed ADS-B Out Avionics Architectures .....	87
Appendix C	Survey of Potential ADS-B Benefits to the Soaring Community .....	89
Appendix D	Detailed Search and Rescue Process .....	93

Appendix E List of Non-Towered Airports With More Than 10,000 Yearly Operations  
and a RADAR Floor In Excess of 1,500ft. ....95

## LIST OF FIGURES

<i>Number</i>	<i>Page</i>
Figure 1: Worldwide Status of ADS-B Implementation in March 2011 (FreeFlight Systems 2009).....	13
Figure 2: Comparison of General Aviation to Air Carrier Active Fleet. General Aviation Includes Air Taxi (BTS) .....	15
Figure 3: Average Yearly Hours Flown by General Aviation Aircraft compared to Air Carrier Aircraft (BTS) .....	15
Figure 4: Schematic Representation of Multi-Stakeholder Cost/Benefit Distribution (Adapted from Marais and Weigel 2007).....	16
Figure 5: Schematic Representation of ADS-B .....	18
Figure 6: Cockpit Display of Traffic Information (CDTI) .....	18
Figure 7: Predicted ADS-B Coverage at Full Implementation .....	22
Figure 8: Temporary Installation of an ADS-B Antenna on a Terminal Area RADAR Tower in Brisbane, Australia (credit: Greg Dunstone).....	22
Figure 9: FIS-B Information Displayed on MFD.....	28
Figure 10: Schematic Representation of an ADS-B Avionics Architecture .....	31
Figure 11: Schematic of Error Effects on GPS Signal.....	34
Figure 12: Effect of Satellite Constellation and Integrity Bounds on Position Accuracy .....	36
Figure 13: Schematic Representation of 95% Position Accuracy of 1m (left) and 0.25m (right). True Position marked With Red Cross. ....	37
Figure 14: Upgrade Paths From Currently Required Equipment to UAT and 1090ES.....	43
Figure 15: Example Disaggregate Cost Benefit Distribution Modified for ADS-B (adapted from (Marais and Weigel 2007)) .....	45
Figure 16: Multi-Stakeholder Cost Benefit Distribution Adopted for the FAA, Air Carrier and GA.....	46
Figure 17: ADS-B and RADAR Coverage in Australia at 10,000ft AGL (Air Services Australia 2011) .....	49
Figure 18: Results From Lester's User Survey .....	51
Figure 19: Predicted ADS-B Surveillance Coverage for the United States .....	56
Figure 20: Percentage of NTSB Mid-Air Collisions by Location.....	60



Figure 21: Track Intersect Angle Summarized for All NTSB Mid-Air Collision Reports.....	61
Figure 22: Location Distribution and Geometry of All NTSB Mid-Air Collisions in the Airport Pattern.....	62
Figure 23: Geometry Distribution for Encounters in the Vicinity of the Airport.....	62
Figure 24: Flight Phases of Mid-Air Collisions Away From the Airport.....	63
Figure 25: Track Intersect Angle for Mid-Air Collisions Away From the Airport With and Without Formation Flights .....	64
Figure 26: Near Mid-Air Collisions Reported in the ASRS Database by Respective Flight Phase. Encounters Along the Diagonal Are Between Aircraft in the Same Flight Phase. ....	65
Figure 27: Near Mid-Air Collisions Reported in the NMACs Database by Respective Flight Phase. Encounters Along the Diagonal Are Between Aircraft in the Same Flight Phase.....	66
Figure 28: Flight Phase And Altitude Distribution of GA/Part 121 Encounters in the ASRS Database.....	67
Figure 29: Flight Phase And Altitude Distribution of GA/Part 121 Encounters in the NMACS Database.....	68
Figure 30: Schematic Representation of Approach to an Airport Without RADAR Surveillance to the Surface .....	72
Figure 31: Altitude of Lowest ETMS Track Over United States in 2004-2005.....	74
Figure 32: Altitude of Lowest ETMS Track Above Ground Level Over US in 2004-2005 And Airports With At least 10,000 Yearly Operations.....	75
Figure 33: Altitude Distribution of Lowest ETMS Track Above All Public US Airports (AGL) .....	76
Figure 34: Altitude Distribution of Lowest ETMS Track Above US Airports (AGL) With More Than 10,000 Yearly Operations.....	77
Figure 35: Towered Airports With Observed RADAR Floors of More Than 500ft.....	78
Figure 36: Non-Towered Airports With More Than 10,000 Yearly Operations and an Observed RADAR Floor Higher Than 500ft AGL.....	79
Figure 37: Number of Non-Towered Airports With More Than 10,000 Yearly Operations Binned by Lowest ETMS Track (32 Airports With RADAR Floors In Excess of 6000ft AGL Are Not Shown).....	80
Figure 38: Schematic Representation of How ADS-B Surveillance Improves Efficiency at Non-Towered Airports During IFR Operations .....	81
Figure 39: Detailed 1090ES ADS-B Avionics Architecture .....	87

Figure 40: Detailed UAT ADS-B Avionics Architecture .....	88
Figure 41: Screenshot of Application Ranking Section in Survey.....	90
Figure 42: Percentage of Participants That Ranked the Respective Application at Medium Benefit or Higher.....	91

## LIST OF TABLES

<i>Number</i>	<i>Page</i>
Table 1: Differences Between 1090-ES and UAT ADS-B Link .....	19
Table 2: Subset of ADS-B Message Elements Required by the Mandate and Their Minimum Performance Requirements.....	21
Table 3: List of Proposed ADS-B Out Applications.....	25
Table 4: List Data Link Applications.....	26
Table 5: List of ADS-B In Applications Proposed in the AIWP .....	28
Table 6: Mapping Between Horizontal Protection Limit (HPL) and ADS-B NIC Values.....	35
Table 7: Mapping Between Horizontal Figure of Merit (HFOM) and ADS-B NACp Values.....	37
Table 8: GPS Avionics Capabilities for General Aviation (FAA Avionics Survey, 2007).....	38
Table 9: Different ADS-B Link Versions and Their Respective Technical Standards.....	40
Table 10: Differences Between Mode A, C and S Transponders (FAA Avionics Survey, 2007).....	41
Table 11: The 17 AIWP ADS-B Applications Identifying What Stakeholders Are Expected To Recieve Benefit.....	53
Table 12: ADS-B In and Out High User Benefit Applications for GA.....	54
Table 13: Format of Heading Information in NTSB Mid-Air Collision Reports .....	60
Table 14: Near Mid-Air Collisions Reported in the Airport Environment.....	66
Table 15: NMAC Encounters by FAR, Ranked by Percentage.....	67
Table 16: Towered Airports With More Than A RADAR Floor Of More Than 500ft (AGL).....	78
Table 17: ADS-B In and Out High User Benefit Applications for GA.....	83
Table 18: Minimum Required ADS-B Message Elements and Their Minimum Performance Requirements .....	85
Table 19: ADS-B In and Out High User Benefit Applications to the Soaring community .....	92



# Chapter 1

## INTRODUCTION AND MOTIVATION

Automatic Dependent Surveillance – Broadcast (ADS-B) is expected to be the basis of the future surveillance system in the United States, supplemented by the current RADAR system. As shown in Figure 1, many other countries worldwide are also implementing ADS-B. Purple circles indicate that a government has evaluated ADS-B and that a move to implement it in the future is likely. Blue circles identify governments that have made the decision to deploy ADS-B and have begun taking the required steps to implement ADS-B. Lastly, green circles identify governments that have implemented ADS-B on a national scale. Partial circles indicate that ADS-B is available in at least part of the country.

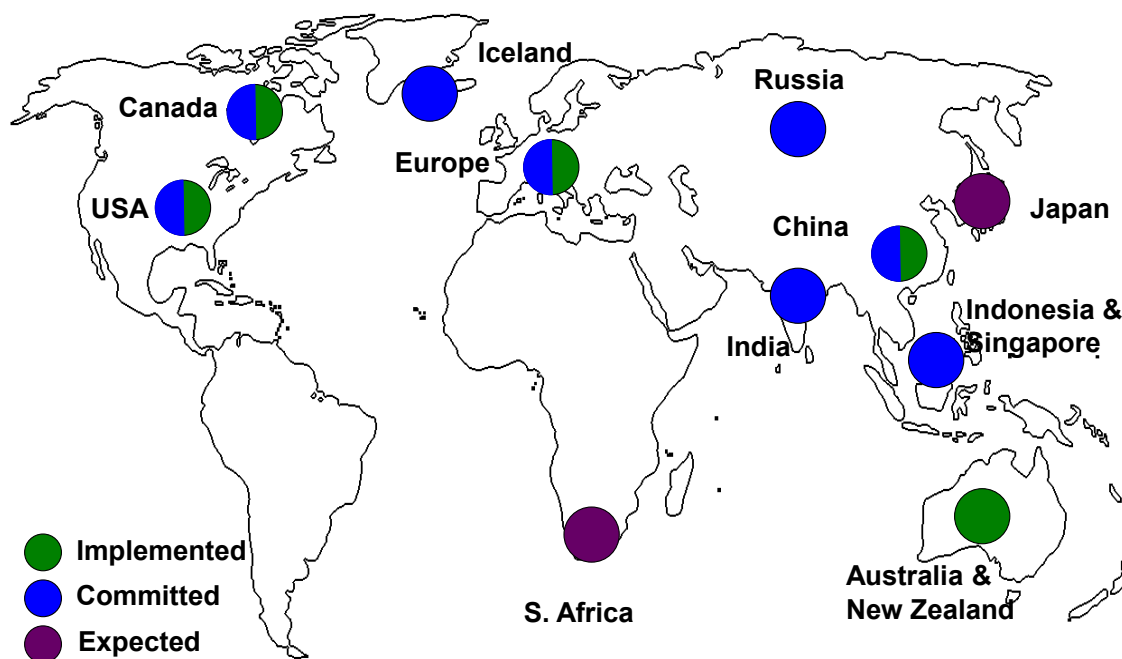

Figure 1: Worldwide Status of ADS-B Implementation in March 2011 (FreeFlight Systems 2009)

ADS-B is a technology where avionics onboard the aircraft broadcast messages with information relevant to Air Traffic Control (ATC) and nearby aircraft once every second. The broadcast information includes: latitude and longitude, aircraft velocity, aircraft altitude, transponder code, the aircraft's call sign as well as other elements.

The ADS-B system also has data link capability where information can be linked from the ground to aircraft while in flight. Information available via data link includes weather data as well as airspace status information (NOTAMs).

The information transmitted from aircraft via ADS-B is first determined by, and thus *dependent* on the aircraft's onboard navigation unit (e.g. GPS or IRU). With aircraft dependent surveillance, the aircraft and its avionics become an integral part of the surveillance infrastructure of the National Airspace System (NAS). As such, ensuring that aircraft are equipped with the required avionics is crucial.

Some of the ADS-B applications require more than one aircraft to transmit ADS-B messages. Thus, benefit from ADS-B to a given user is co-dependent on the level of equipage of other aircraft. As a result, a threshold level of system wide aircraft equipage is required to justify changes in aircraft operation and ATC procedures. Ensuring equipage across all stakeholders to reach this threshold level is thus paramount to the delivery of benefit from ADS-B (Marais and Weigel 2007) One way to stimulate this equipage is to provide benefits that result from use of the technology ("user benefit"). The more user benefit a stakeholder perceives from a given technology, the more likely that stakeholder is to equip with that technology.

Two of the major stakeholders that operate aircraft in the National Airspace System are Commercial Aviation (FAR Part 121 operators) and General Aviation (e.g. Part 91 or 135). In the United States, General Aviation (GA) makes up over 96% of all active aircraft in the National Airspace System. Figure 2 shows the Bureau of Transportation Statistics (BTS) record of all active aircraft from 1960 to 2011. In this plot, Part 135 operations are considered to be part of General Aviation.

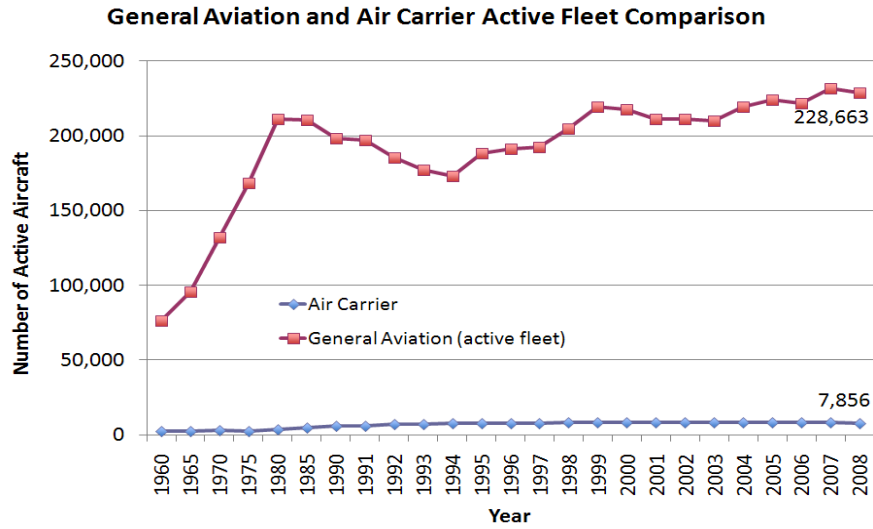

**Figure 2: Comparison of General Aviation to Air Carrier Active Fleet. General Aviation Includes Air Taxi (BTS)**

Though GA aircraft vastly outnumber air carrier aircraft, yearly GA aircraft utilization is much lower, as is apparent in Figure 3. Average yearly hours flown by air carrier aircraft have been increasing over the past years to 2406 hours while General Aviation aircraft have seen a slight decrease to 114 hours. Thus, the average yearly utilization of an air carrier aircraft is 21 times higher than that of a GA aircraft.

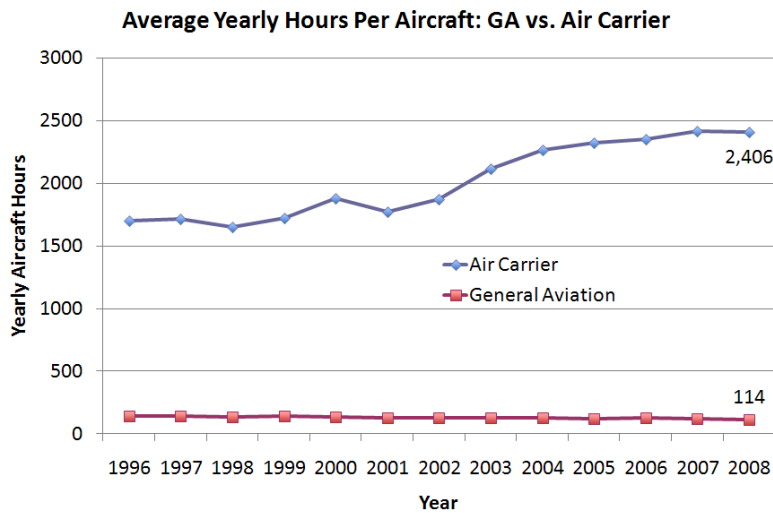

**Figure 3: Average Yearly Hours Flown by General Aviation Aircraft compared to Air Carrier Aircraft (BTS)**

Since many ADS-B user benefits are dependent on utilization, concern exists that ADS-B may not deliver enough user benefit to GA and thus not provide sufficient incentive for GA to equip voluntarily. Additionally, GA tends to be more cost sensitive as expenses often are paid out-of-pocket by the aircraft owner.

A schematic representation of a cost/benefit distribution for of a multi-stakeholder system such as ADS-B is shown in Figure 4 for three hypothetical stakeholders. Stakeholder 3 receives strong benefit at a low cost while stakeholder three incurs higher costs than benefits received. Stakeholder three is thus less likely to equip voluntarily with this technology than stakeholder 1.

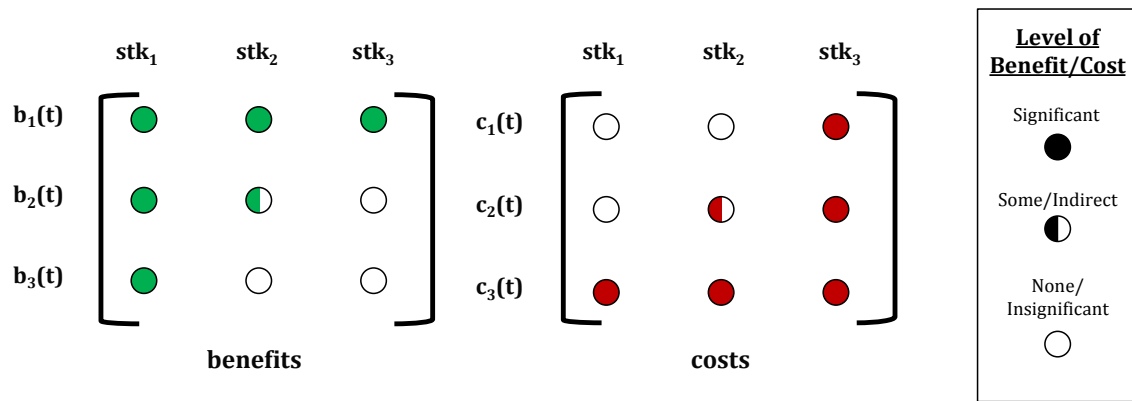

**Figure 4: Schematic Representation of Multi-Stakeholder Cost/Benefit Distribution (Adapted from Marais and Weigel 2007)**

Recognizing the need to ensure high levels of equipage, the FAA in 2009 published a mandate requiring ADS-B equipage for certain airspace by 2020. With a mandate, the benefit of operating in that airspace is tied to equipping with ADS-B, thus creating a strong incentive. However, the Federal Aviation Administration is interested in identifying near-term benefits in order to stimulate voluntary equipage ahead of the mandate as well as to reduce stakeholder opposition. As mentioned, GA presents a special case and thus requires a special focus.

To identify the near term benefits from the perspective of GA, a thorough understanding of GA and the benefits of ADS-B is required. To develop this understanding is the motivation for this thesis.



## Chapter 2

### OVERVIEW OF ADS-B SYSTEM ARCHITECTURE

The current aircraft surveillance system in the US uses ground based RADAR sensors to determine position and velocity of aircraft in the National Airspace System. However, most modern aircraft have advanced navigation systems that are often capable of determining the aircraft's position and velocity much more accurately than RADAR. Taking advantage of that capability, ADS-B broadcasts the more accurate information and thus has the potential to provide higher position and velocity accuracy, direct heading information as well as geometric and barometric altitude. Also, at once per second, ADS-B has a higher update rate than RADAR which updates once every 4.8 seconds in the Terminal Area and once every 12 seconds in en-route airspace. Additionally, since ADS-B only uses relatively simple and low maintenance antennas as ground infrastructure (refer Figure 8), ground station can be placed in more strategic locations, potentially increasing total surveillance coverage area.

Figure 5 is a schematic representation of the overall ADS-B system. Aircraft equipped with ADS-B avionics broadcast their position, altitude, direction and magnitude of ground speed, and other information pertinent to pilots and air traffic controllers at least once per second. This broadcast is defined as "ADS-B Out" and is depicted by the blue arrows in Figure 5. Ground stations receiving these ADS-B messages forward them via a private network to the responsible FAA facilities for display on the air traffic controller's screen. ADS-B Out messages can also be picked up by other aircraft in the vicinity. This capability of receiving ADS-B on-board the aircraft is defined as "ADS-B In" (depicted by the green arrows in Figure 5).

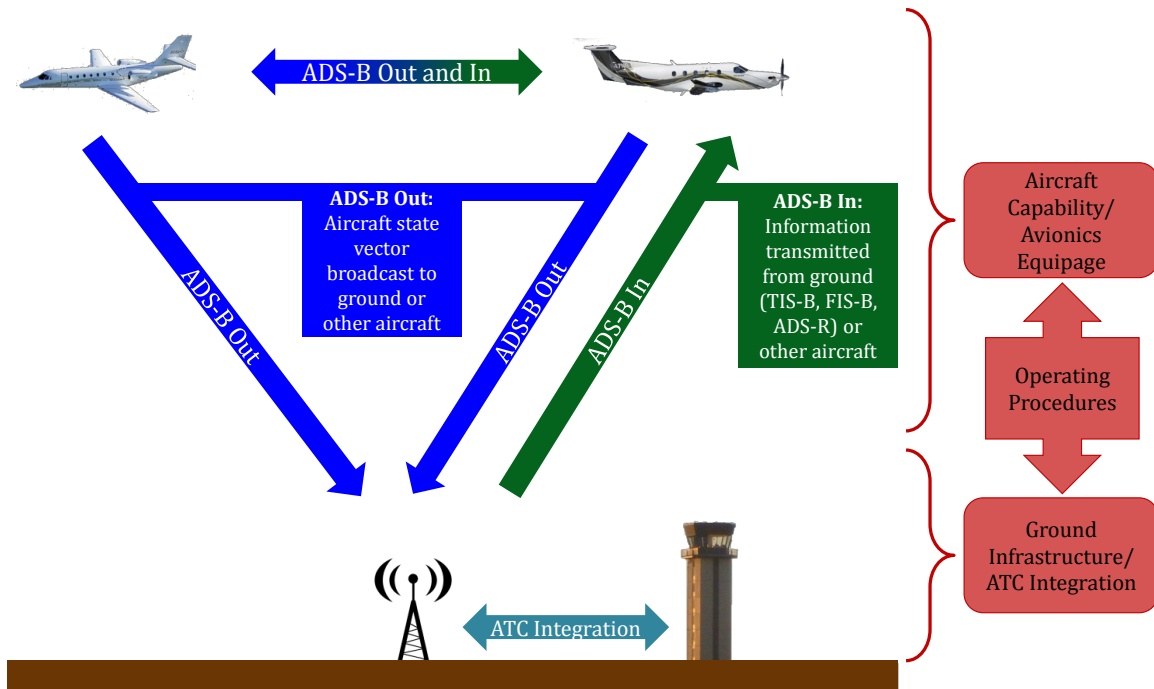

Figure 5: Schematic Representation of ADS-B

ADS-B In messages that originated from other aircraft can be used to display traffic in the vicinity to the pilot using a cockpit display of traffic information (CDTI, Figure 6).



Figure 6: Cockpit Display of Traffic Information (CDTI)

ADS-B also has a data link capability. Messages can originate from the ground stations and be used to uplink additional data directly into the cockpit. Two types of data link messages

have been defined: Traffic Information Service – Broadcast (TIS-B) and Flight Information Service – Broadcast (FIS-B). These messages will provide traffic, weather and NAS Status information to appropriately equipped aircraft.

FIS-B was originally introduced to increase user benefit to GA and thus provide increased equipage incentives. However, the frequency that was originally proposed to be used for ADS-B (1090MHz) had insufficient bandwidth to support FIS-B<sup>1</sup>. As a result, the FAA decided to implement a dual link strategy and provide ADS-B services on two frequencies: 1090ES ADS-B mostly for Air Transport and Universal Access Transceiver (UAT) ADS-B for General Aviation. Table 1 outlines the main differences between the two links. Note that FIS-B is only available on UAT:

**Table 1: Differences Between 1090-ES and UAT ADS-B Link**

	<b>Mode S Extended Squitter 1090ES</b>	<b>Universal Access Transceiver (UAT)</b>
<b>Frequency</b>	1090 MHz	978 MHz
<b>Frequency shared with</b>	TCAS, Primary RADAR, TIS-B, ADS-R	FIS-B, TIS-B, ADS-R
<b>Intended User</b>	Air Transport, High-End General Aviation	General Aviation
<b>Technical Standard</b>	DO-260B, as outlined in TSO-166b	DO-282B, as outlined in TSO-154c

The decision to implement two separate links introduces additional complexity to the ADS-B system: Aircraft on one link are not able to receive ADS-B messages transmitted on the other frequency. To address this issue, Automatic Dependent Surveillance – Rebroadcast (ADS-R) was implemented. ADS-R is the capability of ADS-B ground stations to rebroadcast messages received on the UAT link to the 1090ES link and vice versa. This allows aircraft equipped with ADS-B In to receive ADS-B Out messages from aircraft on the other link with a one second delay.

Introducing UAT also has implication on an international level. The international ADS-B standard is the 1090ES link; any aircraft with UAT ADS-B avionics would have to follow

---

<sup>1</sup> 1090MHz is the interrogation frequency for ground based RADAR. Also, TCAS operates on that same frequency. Concerns exist that adding ADS-B, TIS-B and FIS-B to 1090 would overly congest it and reduce the efficiency of TCAS and RADAR.

special procedures to leave the US since it would not comply with the international 1090ES ADS-B standard.

The FAA has divided ADS-B services into two criticality levels: “Critical” and “Essential”. ADS-B messages transmitted by aircraft as well as ADS-R messages are considered Critical because they support applications such as aircraft surveillance and separation. TIS-B and FIS-B are considered Essential since they are advisory in nature and support applications at an essential but not critical level. (Surveillance and Broadcast Services Program 2010)

As indicated in Figure 5, the overall system architecture can be broken down into three major system elements: Aircraft Capability, Ground Infrastructure and Operating Procedures. Each one of these aspects will be addressed individually.

## **2.1 Aircraft Capability – Aircraft Avionics**

The airborne capability of ADS-B consists of the ADS-B avionics on board appropriately equipped aircraft. In 2009, the FAA published the ADS-B mandate that dictates the required capabilities of these ADS-B avionics. Chapter 3 will address avionics architectures onboard aircraft in more detail – this section introduces the airborne capability and its requirements as part of the overall ADS-B system architecture.

Every ADS-B avionics architecture compliant with the mandate has two core components: A navigation unit providing position and velocity information and an ADS-B transceiver that transmits that information on one of the two link frequencies. One concern among GA is that many active aircraft do not currently have certified navigation units installed. Operators would thus have to equip with a certified navigation unit in addition to an ADS-B transceiver. As addressed in Chapter 3, such navigation units can be expensive.

### **2.1.1 ADS-B OUT MANDATE**

The ADS-B Out mandate outlines requirements and performance standards for ADS-B Out avionics. The rule states that “... [ADS-B Out] equipment will be required for aircraft operating in classes A, B and C airspace [and] certain class E airspace.” This Class E airspace is airspace above 10,000ft and within the Mode C veils of busy airports. Currently, the FAA is not mandating ADS-B In equipage (FAA 2010).

The rule also dictates the minimum contents of the ADS-B message and sets performance requirements for each one of those elements. These performance requirements were set to enable ATC to conduct aircraft surveillance with ADS-B that is at a level equivalent to the

current RADAR based system. However, certain proposed applications of ADS-B may require higher performance requirements than those outlined in the rule. Operators desiring to use those applications would have to equip with equipment that meets those higher requirements. Table 2 lists a subset of the required message elements – Appendix A contains a table listing all elements required by the rule and their performance requirements.

**Table 2: Subset of ADS-B Message Elements Required by the Mandate and Their Minimum Performance Requirements**

<b>ADS-B Message Element</b>	<b>Performance Requirement</b>	<b>Notes</b>
Length and Width of Aircraft	Hardcoded	Only Transmitted on Ground
Latitude and Longitude	Within $\pm 0.05$ NM	In reference to WGS84
Barometric Altitude	N/A	In 25ft Increments
Aircraft Velocity	Within $\pm 10$ m/s	In m/s, not knots
ATC Transponder Code	N/A	Entered via same interface as Transponder
Aircraft Call Sign	N/A	Either N-number or Airline Call Sign

## 2.2 ADS-B Ground Infrastructure

The physical ADS-B Ground Infrastructure consists of the physical ADS-B antennas on the ground, the network infrastructure required to transmit the received messages to the relevant ATC centers as well as the systems required to fuse the surveillance data from ADS-B with surveillance data from the currently existing RADAR infrastructure.

The FAA has externally subcontracted the deployment of the nationwide ADS-B system. Figure 7 shows the predicted ADS-B coverage for the US at full implementation. Areas highlighted in blue have a predicted ADS-B surveillance coverage at or below 1800ft AGL.

794 ADS-B ground stations (depicted in Figure 8) are expected to be deployed in the US by 2013. The contract requires the ADS-B surveillance volume to be equivalent or bigger than the currently existing RADAR volume. However, given the number and locations of planned stations, the actual ADS-B coverage is expected to exceed RADAR coverage in many areas.

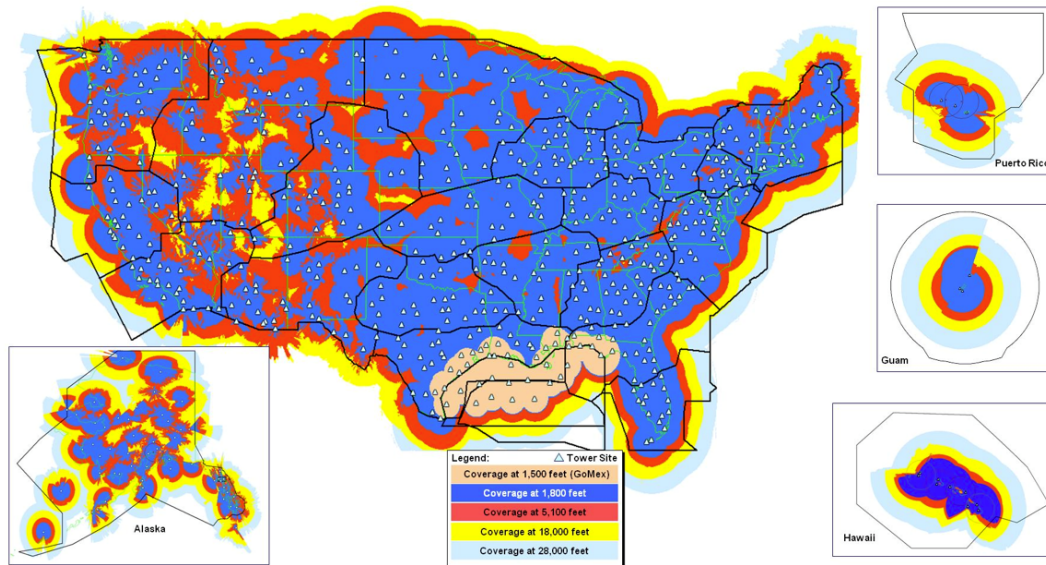

**Figure 7: Predicted ADS-B Coverage at Full Implementation**

Some of the stations will be collocated with existing RADAR infrastructure. Most of the ground stations, however, will be self-contained towers and housing with one omnidirectional UAT antenna and four directional 1090MHz antennas. The towers also have two dual channel communication radios and antennas and in some locations an automatic weather observation station (AWOS) station. To support operations during a loss of electrical power, each station has a diesel generator and batteries.



**Figure 8: Temporary Installation of an ADS-B Antenna on a Terminal Area RADAR Tower in Brisbane, Australia (credit: Greg Dunstone)**

ADS-B messages from aircraft, once received by the ground station, are routed via private networks to three control stations in Ashburn, VA, Dallas, TX and Phoenix, AZ. At those control stations, duplicates are removed (if more than one station received the message) and all messages are grouped by geographical location. “The control stations must then validate targets in one of three ways: correlation with RADAR data, reports from two 1090 radios with the aircraft in view, or pseudo-ranging from a single UAT radio which time tags transmissions. ADS-B messages are then forwarded to the FAA marked as ‘valid’, ‘invalid’ or ‘unknown’.” (Warwick 2010). This process is completed within 0.7sec from reception of the ADS-B message at the ground station. The three control stations also receive the RADAR data from the nationwide Host Air Traffic Management Data Distribution System (HADDSS) and use it to create the TIS-B messages.

## **2.3 ADS-B Operating Procedures**

ADS-B Operating Procedures will supplement the current ATC procedures and outline the interactions between the airborne and the ground-based elements of the ADS-B system.

Current, RADAR based ATC procedures are outlined in FAA/DOT Order 7110.65S, “Air Traffic Control” (FAA 2008). This order is a collection of rules describing how air traffic is to be directed in the NAS by air traffic controllers. A majority of those procedures are for regulating flight in Instrument Meteorological Conditions (IMC). In addition to JO 7110.65S, Federal Aviation Regulations (FAR) Parts 91, 121 and 135 outline rules, rights and procedures of pilots and airlines. Lastly, the Aeronautical Information Manual (AIM) lists recommended procedures for flight operations for pilots.

With the introduction of ADS-B as an additional surveillance source, these existing procedures will need to be amended and updated to allow for operations using ADS-B. The expected changes to these existing procedures can be categorized into two groups: Adoption of existing RADAR procedures where ADS-B surveillance is equivalent to RADAR surveillance and Introduction of new ADS-B specific procedures.

### **2.3.1 ADOPTION OF EXISTING, RADAR BASED PROCEDURES**

The adoption of existing RADAR procedures outlined in 71110.65S allows for their use with ADS-B as well as RADAR surveillance. As such, this step grants “RADAR Equivalence” to ADS-B for surveillance purposes. Examples of procedures in this first category include aircraft vectoring, separation services and VFR Flight Following. In February 2010, the FAA declared “Initial Operating Capability” of ADS-B for surveillance purposes over the Gulf of Mexico. Since then, additional airspace has been added – it is expected that by 2013 ADS-B

based surveillance will be available across all of the US. The improvement in surveillance data quality due to ADS-B may result in a reduction of “play” present in current operations. Also, the additional information present in ADS-B messages may increase overall controller situation awareness.

One promising aspect resulting from the RADAR equivalency of ADS-B is that it would allow for a low cost expansion of the current surveillance coverage volume to remote or mountainous regions. Although these improvements in surveillance coverage and quality offer some benefit, they alone may not warrant the introduction of ADS-B and do not take advantage of much of the information available in the ADS-B message. In order to take advantage of this information, new, ADS-B specific procedures will have to be introduced.

### **2.3.2 INTRODUCTION OF NEW, ADS-B SPECIFIC PROCEDURES**

The introduction of new ADS-B specific procedures enables new capabilities in the NAS. Those capabilities are expected to provide a majority of the benefit from ADS-B. (FAA 2010)

In order to introduce new ADS-B procedures, a rigorous process must be followed to ensure their safety and effectiveness. Required steps include but are not limited to developing a Concept of Operations (ConOps), conducting a full safety analysis (known as Operational Hazard Analysis, or OHA), flight testing and training pilots and air traffic controllers.

The initial focus of the development of ADS-B has been on deploying the ground infrastructure, and as a result the development and definition of procedures has received less attention. In order to deliver benefit from ADS-B, operating procedures are a required. Therefore, the creation of operating procedures is of utmost importance for the delivery of user benefit that ultimately creates incentives for equipage.

## **2.4 ADS-B Applications**

An “ADS-B Application” is a specific purpose for which ADS-B is used in the NAS. ADS-B applications can be grouped into three categories: Data Link Applications, ADS-B Out Applications and ADS-B In Applications. Based on a literature review, 32 proposed applications were identified. The reviewed Literature included: FAA technical documentation such as DO-260 and DO-282, EUROCONTROL’s Action Plan 23 (defines ADS-B implementation strategies for Europe), as well the Application Integrated Working Plan (v2) (FAA 2010). Additionally, in 2009 Jenkins conducted a thorough review of proposed ADS-B applications (Jenkins 2009). The applications listed in her thesis were also included in this review. The applications were then categorized based on the required ADS-B



functionality (Out, In, Data Link) and duplicates removed. These categories are discussed in the following sections.

### 2.4.1 ADS-B OUT APPLICATIONS

ADS-B Out applications are based solely on ADS-B Out transmissions from aircraft and are mostly limited to ATC surveillance applications. Nonetheless, some proposed procedures do take advantage of ADS-B specific information, introducing new capabilities based on ADS-B Out. Table 3 is a list of proposed ADS-B Applications.

**Table 3: List of Proposed ADS-B Out Applications**

<b>Application Name:</b>	<b>Concept/Description :</b>
ATC Surveillance in Non-RADAR Airspace (ADS-B-NRA)	Provide ATC surveillance in non-RADAR areas such as below current RADAR coverage or offshore operations areas (e.g. Gulf of Mexico) using current RADAR Procedures. Conceivably, new procedures could be created using surveillance information provided by the ADS-B message.
ADS-B Flight Following	Due to the higher coverage volume and the increased surveillance quality and information available, ATC will be able to better advise pilots of nearby traffic, minimum safe altitude warnings (MSAW), etc.
Improved Search and Rescue	Flight track data serves as an input to search and rescue operations. Having better accuracy of the last known position, a faster update rate, more specific information about the aircraft as well as a bigger coverage area, ADS-B will enable more efficient and more accurate responses to emergency situations.
Company/Online Flight Tracking	Current Flight Tracking is limited to areas with SSR coverage. ADS-B increases this coverage. Information available in the ADS-B message allows aircraft to be identified more readily. This would, e. g., allow operators or companies to improve their fleet scheduling.
ATC Surveillance for En-Route Airspace (ADS-B-ACC)	ATC will use ADS-B surveillance information in the same manner as RADAR surveillance, e.g., to assist aircraft with navigation, to separate aircraft, and to issue safety alerts and traffic advisories. The ADS-B surveillance information will be used to enhance the quality of existing RADAR-based surveillance information. Conceivably, a 3NM separation standard may be acceptable.
ATC Surveillance in Terminal Areas (ADS-B-TMA)	Current RADAR surveillance will be enhanced in Terminal Areas. An example would be airports with single RADAR coverage. ADS-B information could be used to enhance current ATC procedures or ATC automation systems such as tracking or minimum safe altitude warnings (MSAW).

Airport Surface Surveillance and Routing Service	ADS-B surveillance is provided to air traffic controllers to enhance situational awareness with respect to vehicles (including ground vehicles) operating on the airport surface. ADS-B surveillance may also be provided to ground automation and decision support system to aid in the management of traffic flow on the airport surface. This application may allow ASD-X like environments at non ASD-X airports. Conceivably, a pilot or ATC alerting function could be added to this application.
ATC Automation Integration/Automatic Flight Plan Cancellation	Using information provided by the ADS-B message, some ATC functions could be automated. One such application could be automatic flight plan opening or closing.
ADS-B Enhanced Parallel Approaches/ADS-B PRM	This application applies to two different environments. First, it would enhance parallel approaches at airports which use a precision runway monitoring RADAR (PRM). ADS-B may enhance surveillance quality. Second, ADS-B surveillance may allow airports without PRM to have a PRM like environment.
ADS-B Emergency Locator Transmitter (ELT)	The ADS-B message has the capability to transmit a "Downed Aircraft" message. This could double as an ELT functionality.
Enhanced Tower Situational Awareness in Reduced Visibility	Using ADS-B, a virtual image could be created to aid Situation Awareness for tower controllers.
ADS-B Enabled Portable Devices for Airport or FBO Employees	Airline Employees (e.g. ramp operators) receive ADS-B reports from aircraft in their fleet and use the data to optimize allocation of ground infrastructure, such as gate space and support vehicles.
Weather Reporting to Ground	If aircraft are equipped accordingly, weather specific information could be transmitted via the ADS-B message improving weather briefings to pilots on the ground and to enhance forecasting.

#### 2.4.2 DATA LINK APPLICATIONS: FIS-B AND TIS-B

Data link applications take advantage of the capability of ADS-B to link data directly to the cockpit. Traffic Information Service – Broadcast (TIS-B) and Flight Information Service – Broadcast (FIS-B) are examples of this kind of application. These applications are called “Essential Services” for FAA and ATC purposes.

**Table 4: List Data Link Applications**

<b>Application Name:</b>	<b>Concept/Description :</b>
TIS-B	Using secondary RADAR surveillance data, messages of non-ADS-B traffic are transmitted to the aircraft. TIS-B is not expected to be required once a threshold level of equipage is achieved.
FIS-B	FIS-B messages contain weather data (such as Doppler RADAR images) as well as NAS status information (NOTAMS, TFRs, etc.) and are updated every 5 minutes.

With TIS-B, traffic information is linked directly to the cockpit from the ground. ITT, the main contractor installing the ground infrastructure for ADS-B describes TIS-B as follows: “The TIS-B service provides active ADS-B users with a low-latency stream of position reports of non-ADS-B equipped aircraft” (ITT 2010) These reports are generated using secondary RADAR data. TIS-B traffic information is in addition to the ADS-B messages received directly from other ADS-B aircraft via ADS-B In.

TIS-B is not continuously transmitted. For a ground station to start transmitting TIS-B to a given aircraft, two requirements have to be met: First, that aircraft has to be transmitting ADS-B Out and be capable of receiving ADS-B In. Second, there has to be a non-ADS-B target within the vicinity of that aircraft.

The FIS-B service is a broadcast of weather and NAS status information. The broadcast data is specific to the location of a given ground station. FIS-B is only broadcast on UAT and not on 1090ES. Unlike TIS-B, FIS-B is broadcast regardless of whether any “client” aircraft are in the service volume. FIS-B currently contains the following weather and NAS products: (ITT 2010)

1. AIRMET
2. SIGMET
3. Convective SIGMET
4. METAR
5. PIREP
6. TAF
7. Winds/Temperatures Aloft
8. CONUS NEXRAD
9. Regional NEXRAD
10. NOTAM
11. SUA

Similar to TIS-B, the information received via FIS-B can be displayed in the cockpit on a separate Multifunction Display (MFD, Figure 9) or possibly on a CDTI in combination with TIS-B.

Data Link applications are expected to provide substantial benefit to GA. GA often does have access to this kind of data while in flight. Providing free access traffic information, weather and NAS status information is expected to aid flight crews in decision making and thus reduce accidents.



Figure 9: FIS-B Information Displayed on MFD

### 2.4.3 ADS-B IN APPLICATIONS

ADS-B In applications are enabled by the ability of aircraft to receive ADS-B messages from surrounding aircraft. Applications of this kind are expected to introduce new capabilities into the NAS as well as move some of the functions ordinarily performed by ATC to the pilot. Much ADS-B user benefit is expected from this kind of application.

In a recent effort to get consensus on the definitions and functionalities of ADS-B In applications, the FAA created the ADS-B Integrated Working Plan (AIWP). The AIWP was written by a government/industry panel focusing on the identification and definition of ADS-B In applications. Table 5 lists the applications and their description as identified by the AIWP. (FAA 2010)

Table 5: List of ADS-B In Applications Proposed in the AIWP

Application Name:	Concept/Description :
Traffic Situation Awareness-Basic	Flight crews use this application [...] to supplement their visual scan. The display enables detection of traffic by the flight crew. The information provided on the display also reduces the need for repeated air traffic advisories and is expected to increase operational efficiencies.
Traffic Situation Awareness for Visual Approach	The flight crew uses the display to assist in the visual acquisition of a specific target to follow and manual selection of the traffic for coupling. The cockpit display provides ground speed or closure rate information relative to the coupled target continuously throughout the approach.
Airport Traffic Situation Awareness	The application is expected to be used by the flight crew to aid in detection of traffic related safety hazards on taxiways and runways including aircraft on final approach. This assists the flight crew with early detection of traffic conflicts and runway incursions.

Airport Traffic Situation Awareness with Indications and Alerts	adds to the Airport Traffic Situation Awareness application by graphically highlighting traffic or runways on the airport map to inform flight crew of detected conditions which may require their attention.
Oceanic In-Trail Procedures	Oceanic In-Trail Procedures (ITP) enables flight level change maneuvers that are otherwise not possible within Oceanic procedural separation standards. ITP allows ATC to approve these flight level change requests between properly equipped aircraft using reduced procedural separation minima during the maneuver.
Flight-Deck Based Interval Management-Spacing	Flight-Deck Based Interval Management-Spacing (FIM-S) is a suite of functional capabilities that can be combined to produce operational applications to achieve or maintain an interval or spacing from a target aircraft.
Traffic Situation Awareness with Alerts	Provides pilots and flight crew of non-TCAS equipped aircraft with enhanced traffic situational awareness in all classes and domains of airspace by delivering traffic advisory alerts in the near term.
Flight-Deck Based Interval Management-with Delegated Separation	Flight-Deck Based Interval Management-Delegated Separation (FIM-DS) is a suite of functional capabilities that build upon FIM-S and can be combined to produce operational applications that delegate responsibility for separation from a target aircraft to the flight crew.
Independent Closely Spaced Routes	This airborne capability is expected to facilitate closer spacing between routes, which will enable greater use of terminal, en route, and oceanic airspace.
Paired Closely Spaced Parallel Approaches	To allow flight crews to conduct instrument approach procedures simultaneously to closely – spaced parallel runways increasing airport capacity and efficiency of ATC and flight operations.
Independent Closely Spaced Parallel Approaches	When weather conditions dictate the use of instrument approaches, arrival rates decrease, resulting in delays. It is expected that Independent Closely Spaced Parallel Approaches (ICSPA) will be applicable to runways spaced between 2,500 and 4,300 feet.
Delegated Separation-Crossing	Enables ATC to resolve a conflict by issuing either a lateral or vertical crossing clearance and delegating separation responsibility to the flight crew with respect to ATC designated target aircraft.
Delegated Separation-Passing	Enables ATC to resolve an along-track overtake conflict by issuing either a lateral or vertical passing clearance and delegating separation responsibility to the flight crew with respect to an ATC designated target aircraft.
Flight Deck Interval Management – Delegated Separation with Wake Risk Management	Increases capacity by enabling reduced airborne separation minima within the current wake avoidance limits by providing aircraft-based tools for managing wake risk when conducting delegation separation with FIM-DS.
ADS-B Integrated Collision Avoidance	Further increases capacity by enabling reduced airborne separation minima. This is achieved by integrating ADS-B data with the TCAS system to create a more robust collision avoidance system (CAS) for ground separation, delegated separation, and self-separation operations in all conditions.

Flow Corridors	Flow corridors consist of tubes or “bundles” of near-parallel trajectories in the same direction, which consequently achieve a very high traffic throughput, while allowing traffic to shift as necessary to enable more effective weather avoidance, reduce congestion, and meet special use airspace (SUA) requirements.
Self-Separation	The flight crew of a self-separating aircraft assumes responsibility from the ATC for separation from all traffic for a defined segment of the flight. As part of its delegated separation responsibility, the flight crew is granted authority to modify its trajectory within defined degrees of freedom without renegotiating with ATC.

## Chapter 3

# ADS-B AVIONICS ARCHITECTURES FOR GENERAL AVIATION

In general, four main system components can be identified in any ADS-B installation. Figure 10 is a schematic representation of a typical ADS-B Avionics Architecture:

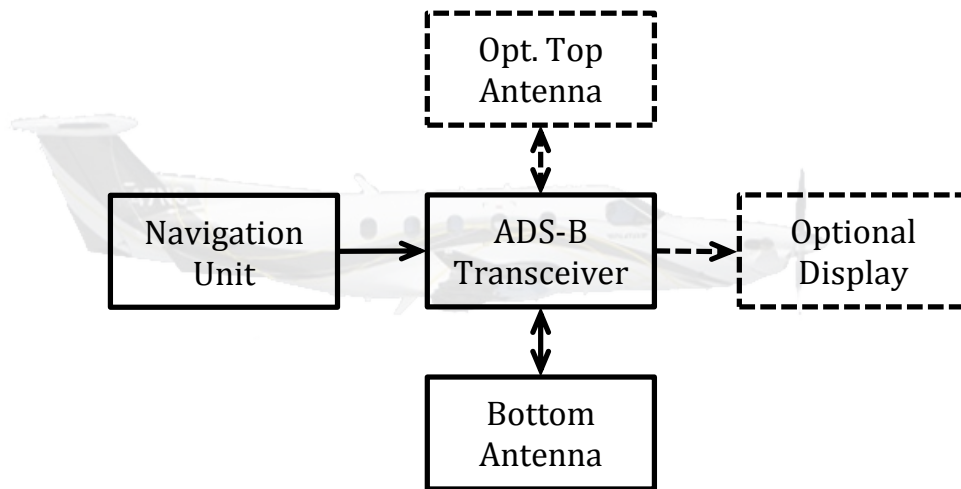

Figure 10: Schematic Representation of an ADS-B Avionics Architecture

1. **Navigation Unit:** This can be a GPS, an Inertial Reference Unit (IRU) or any other device that meets the performance requirements for position and velocity information outlined in the final ADS-B Out rule.
2. **ADS-B Transceiver:** This component transmits the ADS-B message. It collects information from the navigation unit, altimeter and other sources and assembles the ADS-B message. It also receives and decodes ADS-B In messages.

3. **Display:** This component is optional under the ADS-B Out mandate. If the transceiver is ADS-B In capable, this display will be used to display traffic, weather and NAS status information to the pilot.
4. **Antennae:** For 1090ES ADS-B, messages can be transmitted via a transponder antenna. For UAT, an antenna diplexer is used to allow the transponder antenna to be shared with the ADS-B unit.

This chapter addresses each one of these components individually.

### 3.1 Navigation Unit

The quality of the position and velocity information transmitted via ADS-B ultimately depends on the performance of the navigation unit. The ADS-B mandate does not specify the type of navigation unit that is to be used – as long as it meets the performance requirements outlined in Table 2 it may be used for ADS-B. In the text of the mandate, however, the FAA states:

*“... operators may equip with any position source. Although [GPS] WAAS is not required, at this time it is the only positioning service that provides the equivalent availability to radar (99.9 percent availability). The FAA expects that future position sources [...] will also provide 99.9 percent availability.”*  
(FAA 2010)

Availability is the measure of how certain it is that a given service is available. In this case, the FAA mandate requires the positioning service to be available at least 99.9% of the time. Much of General Aviation uses GPS as either supplemental or primary navigation rather than other systems. The rest of this section will therefore focus on how GPS is used for ADS-B.

GPS uses a constellation of satellites to determine the location of a receiver on earth. The satellites transmit signals that can be picked up by the receiver. The receiver can then calculate the time it took the signal to travel from the satellite to the receiver. Knowing the velocity at which the signal travels, that time is then used to determine the distance between the two. This distance can be pictured as the radius of a hollow sphere around the satellite – the receiver is somewhere on the shell of that sphere. As the receiver adds the signal from a second satellite, a sphere can be calculated for it also. The location of the receiver now has to fulfill two conditions – be on the surface both shells. Geometrically, this condition is satisfied anywhere where the two spheres intersect (a circle). Adding a third



sphere, the intersection of all three spheres is reduced to two locations in space (where the third sphere intersects the circle). Selecting between those two locations is trivial since generally only one of them is on the earth's surface.

As mentioned, the time the signal travels through space is the parameter used to calculate the radius of the spheres. When calculating the time required for the signal to travel through space, the receiver needs to have a reference time for the time measurement. Any inaccuracies in this time measurement by the receiver would greatly affect the calculated radii of the spheres and with the position estimate. Therefore, in order to avoid this error, the reference time of the receiver (just as the location) is assumed to be an unknown and calculated along with the position of the receiver. This, however, requires an additional satellite to be acquired by the receiver: four unknowns (position (X, Y, Z) and time) to be calculated by four satellites.

As the physical GPS signal travels through space it is subject to the introduction of certain errors: errors from atmospheric effects, shifts in satellite orbits, satellite clock errors, signal multipath errors, calculation/rounding errors and tropospheric effects. Ionospheric and tropospheric effects result in a slight distortion of the signal away from straight line travel, artificially increasing the distance traveled by the signal. The receiver then interprets that as a larger radius to the sphere around that satellite, resulting in an offset in calculated position. Satellite specific errors such as clock drift and orbit shifts also add errors to the position calculation. Lastly, a multipath error can be introduced if the receiver acquires a signal that has bounced off of a building or some other reflective surface like lakes or snow-covered mountains. The signal from any GPS satellite can be affected by any of these errors at any time. Lastly, a satellite can enter a faulty mode altogether and introduce a consistent offset to the position estimate unless the fault is detected.

Returning to the analogy of the hollow sphere, these errors introduce thickness to the shell of that sphere. Rather than being on the surface of a sphere, the receiver is now somewhere inside a shell with a thickness determined by the present signal errors. Figure 11 schematically represents the effect such errors can have the receiver calculated distance between itself and the satellite. As multiple satellites are used to calculate a position, these errors get compounded and ultimately determine the quality of the position estimate.

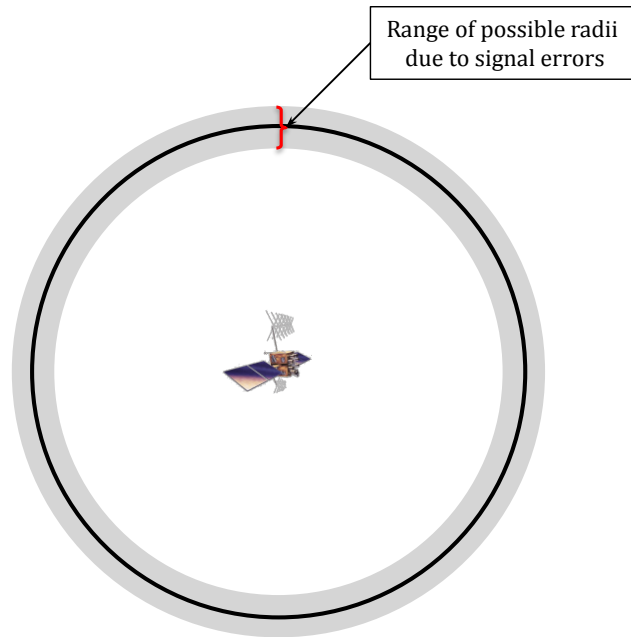

**Figure 11: Schematic of Error Effects on GPS Signal**

One element in the ADS-B message is the navigation unit's position information. This position information is used in ATC surveillance applications as well as aircraft to aircraft applications and thus needs to be reliable and not contain excessive amounts of error. To quantify the probability and magnitude by which a GPS position estimate is affected by signal errors, the terms GPS Integrity and Accuracy were introduced.

### **3.1.1 GPS INTEGRITY**

The integrity of a GPS position estimate defines the region assured to contain the estimated horizontal position. Specifically, it gives the radius to a circle centered at the true position that is assured to contain the position transmitted in the ADS-B message – the smaller the radius, the better the integrity. This radius is referred to as the Horizontal Protection Limit (HPL). A major attribute of the HPL is that it not only bounds the maximum error but also identifies the area within which the probability that a faulted satellite is detected and excluded is at least 99.9%. In other words, the HPL is a measure of the maximum possible magnitude of uncorrected signal errors present in the position estimate. For ADS-B, the HPL value is represented in the NIC value that is required to be sent out via the ADS-B message. Table 6 maps the HPL values to the ADS-B NIC values. For ADS-B, the minimum required value of NIC is 7 which corresponds to an HPL of less than 370 m.

**Table 6: Mapping Between Horizontal Protection Limit (HPL) and ADS-B NIC Values**

<b>Horizontal Protection Limit</b>	<b>NIC Value</b>
HPL Unknown	0
HPL < 20nm (37 km)	1
HPL < 8nm (15 km)	2
HPL < 4nm (7.4 km)	3
HPL < 2nm (3.7 km)	4
HPL < 1nm (1.8 km)	5
HPL < 0.5nm (926 m)	6
HPL < 0.2nm (370 m)	7
HPL < 0.1nm (185 m)	8
HPL < 75 m	9
HPL < 25 m	10
HPL < 7.5 m	11

Using GPS integrity monitoring, GPS receivers ensure that the effects of errors on the position estimate are minimal. Most aviation GPS navigation units monitor GPS integrity at all times – in case the uncorrected error increases above a certain limit, navigation is no longer possible, the pilot needs to be alerted and a secondary means of navigation should be used.

GPS Integrity Monitoring is achieved in two major ways in aviation receivers: Receiver Autonomous Integrity Monitoring (RAIM) and Satellite Based Augmentation System (SBAS). SBAS in the United States is known as WAAS or Wide Area Augmentation System. RAIM uses redundant satellites that are in view of the receiver to cross-check the calculated position – if errors exist, the faulty satellite signal can be detected and excluded in future calculations. WAAS uses ground based receivers that are located at precisely surveyed locations. Since the locations of the receivers are precisely known, any difference in the receiver calculated position would therefore be from the error present in the signal. Knowing the magnitude of this error, messages are broadcast to any WAAS enabled GPS receivers anywhere in the NAS. Those receivers can then correct their own position estimate by that value. This allows for a substantial increase in GPS Accuracy (discussed in next section) but it also allows for the possibility to transmit messages about faulted satellites, reducing the possibility of a receiver using a faulted satellite in its calculation. As a result, integrity is improved.

### 3.1.2 GPS ACCURACY

GPS accuracy is a measure for how well the GPS receiver is able to match the position estimate to its true position. As opposed to integrity, GPS accuracy assumes that all satellites are healthy and that there are no anomalous errors present in the signal. Specifically, it describes the “radius of a circle in the horizontal plane [...], with its center being at the true position, which describes the region assured to contain the [ADS-B transmitted] position with at least a 95% probability.” (RTCA 2006)

The radius depends on the satellite geometry as well as the errors present in the signal. When a receiver calculates its location, the result will lie somewhere inside the box marked in red in Figure 12. As can be seen on the left, poor satellite geometry creates a larger overlap and thus a larger region within which the receiver could be. On the right, a better satellite constellation reduces the possible region. From Figure 12 it is also apparent that the position accuracy can be improved by reducing the width of the gray area, or, by reducing the uncorrected error in the signal.

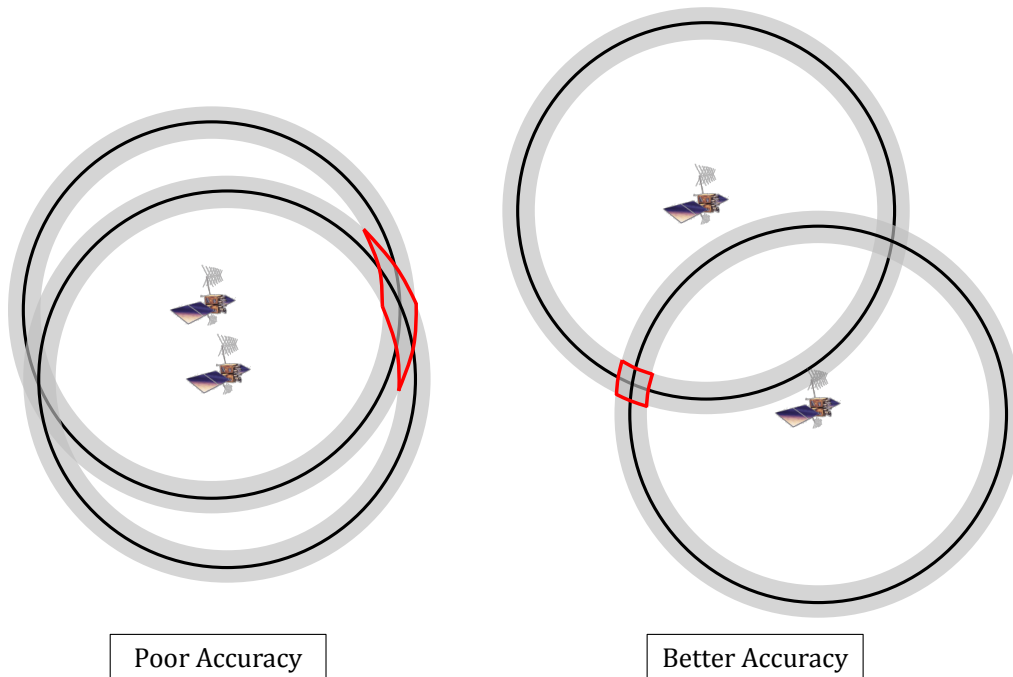
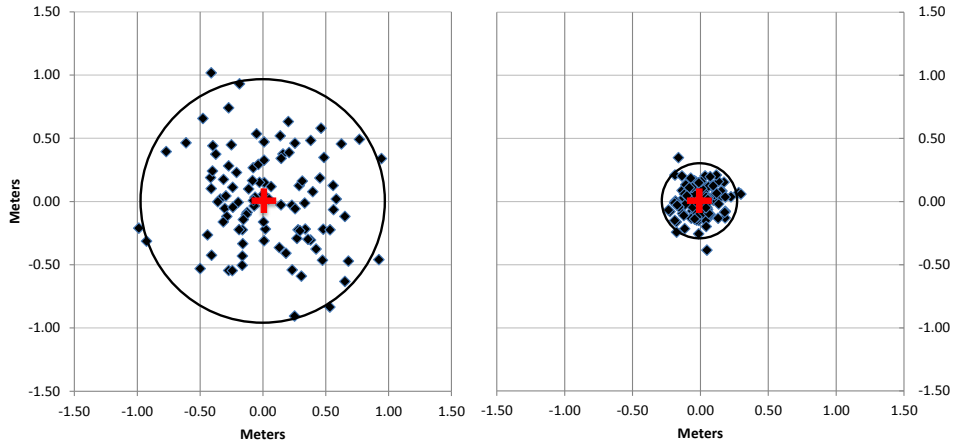

Figure 12: Effect of Satellite Constellation and Integrity Bounds on Position Accuracy

One way to visualize position accuracy is shown in Figure 13 for two different levels of accuracy. If 100 measurements are taken, the 95% accuracy is the radius of the circle, centered at the true position, which contains 95 of the position measurements. The 95% accuracies are shown in Figure 13 as black circles.



**Figure 13: Schematic Representation of 95% Position Accuracy of 1m (left) and 0.25m (right). True Position marked With Red Cross.**

The radius of the 95% accuracy bound is referred to as the Horizontal Figure of Merit (HFOM). For ADS-B, the HFOM is mapped to the NACp Values as shown in Table 7. For ADS-B, the minimum required NACp is 8 which corresponds to a HFOM of less than 93 m.

**Table 7: Mapping Between Horizontal Figure of Merit (HFOM) and ADS-B NACp Values**

<b>Horizontal Figure of Merit</b>	<b>NACp Value</b>
HFOM > 10nm (18.5 km)	0
HFOM < 10nm (18.5 km)	1
HFOM < 4nm (7.4 km)	2
HFOM < 2nm (3.7 km)	3
HFOM < 1nm (1.8 km)	4
HFOM < 0.5nm (926 m)	5
HFOM < 0.3nm (556 m)	6
HFOM < 0.1nm (185 m)	7
HFOM < 0.05nm (93 m)	8
HFOM < 30 m	9
HFOM < 10 m	10
HFOM < 3 m	11

### 3.1.3 COMMON GPS SYSTEMS USED IN GA

To comply with the ADS-B Out mandate, an aircraft will have to be equipped with a Navigation unit that meets the performance requirements stated in Table 2. As mentioned, the ADS-B Out mandate does not explicitly require a WAAS GPS navigation unit but states that it is currently the only technology that provides the required availability.

GA aircraft are equipped with a range of GPS navigation units. Table 8 shows the GPS avionics capabilities for General Aviation as of 2007.

**Table 8: GPS Avionics Capabilities for General Aviation (FAA Avionics Survey, 2007)**

Type of GPS	Technical Standard	Percentage of GA
Overall GPS Equipage (any type of GPS)	N/A	64%
WAAS GPS	TSO-C146a/c	18%
Non-WAAS GPS, IFR approved	TSO-C129a	35%

The WAAS and non-WAAS GPS systems listed in Table 8 are most often a standalone, panel-mounted navigation unit. Though designed primarily for navigational use, many of these systems have the capability to potentially output position information to an ADS-B system. TSO-C146 systems are standalone WAAS GPS systems that meet the required ADS-B accuracy and integrity requirements. TSO-C129a systems, however, are generally not accepted as TSO-C129 was not written for ADS-B systems. In recent months the FAA has begun an effort to evaluate whether or not such systems could potentially meet the ADS-B requirements. If successful, this would result in a significant cost reduction for GA as many aircraft owners would no longer be required to upgrade their navigation units. Many new GPS WAAS systems can be expensive with cost upward of \$10,000.

## 3.2 ADS-B Transceiver

The ADS-B Transceiver is the component that collects the information listed in Table 2 and assembles it into the required message format. Depending on the link that is chosen (UAT vs. 1090ES), the physical unit differs significantly: 1090ES ADS-B transceivers are much like a Mode S transponder – in fact, they also function as Mode S transponders at the same time. A UAT ADS-B transceiver is a standalone component that solely fulfills the function of assembling and transmitting the ADS-B message.

1090ES ADS-B Transceivers use a modified version of the Mode S transponder reply to RADAR interrogations. Instead of directly replying to a RADAR interrogation, 1090ES

transceivers transmit limited ADS-B messages every 0.5 seconds. Full 1090ES messages are transmitted every 1 second. 1090ES ADS-B transceivers have to be certified to TSO-166b which references RTCA standard DO-260B. Since this standard is very recent, no commercially available transceivers currently match this standard. It is expected that many existing Mode S transponders as well as 1090ES ADS-B transceivers certified to an earlier version of DO-260 can be made compliant with TSO-166b with a software upgrade (on the order of \$3000). New installations of 1090ES Transceivers are expected to be in the same cost range of current Mode S transponders (starting at \$4000 plus installation, as of late 2010).

UAT Transceivers use a different message structure as well as operating frequency (978 MHz) than 1090ES ADS-B transceivers. Nonetheless, the required message content is the same as what's required for 1090ES. Since the ADS-B Out mandate has been published, many GA avionics manufacturers have announced the development of UAT ADS-B avionics. In fact, manufactures have proposed and are developing "GPS/UAT ADS-B-in-one" as well as a UAT/Mode C-in-one", both starting at \$3500. Cost may increase depending on what kind of additional upgrades, purchases or installations are required.

In order to receive ADS-B In, the ADS-B transceiver has to be capable of receiving ADS-B messages. An ADS-B In capability is not required by the FAA mandate. It is conceivable that manufactures will develop ADS-B transceivers that are capable of receiving and/or transmitting on both ADS-B links. This could potentially allow aircraft that are equipped with a 1090ES system to still receive the benefits of FIS-B which is only transmitted on UAT.

### **3.2.1 HISTORICAL ADS-B TRANSCEIVERS**

Between 1999 and 2006, the FAA conducted the Capstone Program in Alaska. Under Capstone, ADS-B avionics were provided to operators in Alaska to conduct a first large scale evaluation of ADS-B. The main ADS-B transceiver used in the project was the Garmin GDL 90 ADS-B Transceiver. The GDL 90 contained a GPS unit along with a UAT ADS-B Transceiver all contained in one box. The GDL 90 is no longer commercially available.

The GDL 90 was part of the first wave of ADS-B transceivers. Today's ADS-B avionics have to be installed in accordance with one of two technical standards: DO-260B or DO-282B. Early receivers, however, were built according to DO-260 and DO-282 (no B), the then current versions of these standards.

Since then, the FAA and industry have identified serious flaws with this first version of the standards - namely, the position integrity (NIC) and accuracy (NACp) were combined into one "uncertainty category" (NUC). The various avionics manufacturers interpreted this

parameter differently, resulting in a lack of consistency across the broadcast messages. Also, additional issues specific to the GPS units used for those early installations have been identified. As a result, these technical standards have since been updated twice to address these issues (hence version B).

Depending on what standard was used when the avionics were built, the avionics are said to be on different link versions. Table 9 shows the three different links and their respective technical standards. Under the ADS-B mandate, only link version 2 messages will be accepted.

**Table 9: Different ADS-B Link Versions and Their Respective Technical Standards**

<b>Link Version</b>	<b>Technical Standard</b>	<b>Date Published</b>
Version 0	DO-260/DO-282	2003/2004
Version 1	DO-260A/DO-282A	2006/2006
Version 2	DO-260B/DO-282B	2009/2009

### **3.3 Cockpit Displays for ADS-B In**

If an aircraft has an ADS-B transceiver that is capable of receiving ADS-B-In, the aircraft needs to be equipped with a display that can be used to display the received information to the flight crew. Depending on the operations that are desired for a given aircraft, the required level of certification of those avionics and displays varies. It is expected that most displays currently available and installed in many GA aircraft will be allowed for displaying ADS-B information received via ADS-B In, TIS-B or FIS-B. Some manufacturers even intend to use existing GPS displays to depict traffic and weather data. Multifunction Displays (MFDs) can also be used to display such information. A stand-alone MFD costs approximately \$8000. However, if ADS-B In is expected to be used for advanced applications such as separation between aircraft, the display would have to be certified to more stringent standards (DO-317). This may result in the operator having to upgrade or purchase an additional display. As mentioned, the mandate does not require ADS-B In capability.

Since FIS-B and TIS-B are considered to be essential services and thus advisory only, some manufacturers have developed systems that use an ADS-B receiver solely capable of ADS-B In. Using an iPad or similar electronic device, a pilot can then receive FIS-B and/or TIS-B.



### 3.4 Antennae

The FAA mandate requires a single, down-looking antenna for ADS-B. However, the FAA strongly encourages operators to install a secondary, top antenna. This top antenna prevents fuselage shielding of the bottom antenna, allowing for more advanced ADS-B In applications that require a “view” of the sky above the aircraft.

1090ES ADS-B installations use the same frequency as Mode A/C/S transponders do. As such, antennas can be used for ADS-B as well as transponder transmissions. UAT, however, transmits on 978 MHz. In order to minimize the cost of installation for UAT, the final ADS-B out mandate allows for the use of an antenna diplexer. This antenna diplexer enables the simultaneous use of the transponder antenna by the UAT transceiver as well as the transponder.

### 3.5 Upgrade Paths From Transponder Based Surveillance Systems

Surveillance in the NAS currently relies on ground based RADAR systems. RADARs send out pulses of radio waves that reflected off of objects in their paths. Using this reflection, the object’s size, distance altitude and flight direction can be determined. Known as primary surveillance, it was the sole means for aircraft surveillance in early years of the NAS. Subsequent upgrades to the RADAR system introduced secondary surveillance. Secondary surveillance systems send out pulses of radio waves known as “interrogations” to which transponder onboard the aircraft reply with an ATC assigned code and, depending on the “Mode” of reply, with other information. Table 10 lists the different Modes and their respective Technical Standards Orders. The ATC code is a distinct code assigned by ATC that identifies the aircraft in the FAA’s HOST computer system and is entered each flight by the flight crew. In order to operate in certain airspace in the US, aircraft have to be capable of secondary surveillance and are thus required to have a transponder (FAR 91.215).

**Table 10: Differences Between Mode A, C and S Transponders (FAA Avionics Survey, 2007)**

	<b>Functionality</b>	<b>Technical Standard</b>	<b>Percentage of GA</b>
<b>Mode A</b>	Distinct ATC Code	TSO-C74b	7%
<b>Mode C</b>	Mode A and Pressure Altitude	TSO-C74c	77%
<b>Mode S</b>	Mode C plus ICAO 24-bit address	TSO-C112c	12%

In order to have a mandate compliant ADS-B Out installation, existing avionics can be upgraded or new components can be installed. Among GA, the most common surveillance avionics architecture today consists of an altitude encoding altimeter, a Mode C transponder and a bottom mounted antenna (Figure 14, top). Architectures found onboard commercial aircraft are significantly more complex and are not considered here.

As shown in Table 10, 77% of GA aircraft have a Mode C surveillance avionics architecture. It is expected that most of those aircraft would be upgraded to UAT ADS-B (right hand path in Figure 14). However, 12% of the GA fleet currently uses Mode S transponders. Since many of the existing Mode S transponders can be upgraded to 1090ES ADS-B via a software upgrade, an upgrade to UAT may be unnecessary and more expensive. As a result, even though GA is expected to mostly equip with UAT, some of GA will upgrade exiting Mode S transponders to broadcast 1090ES ADS-B (left hand path in Figure 14). In Figure 14, arrows indicate information flow, green boxes are pre-existing equipment and red boxes indicate components that would have to be added to enable ADS-B mandate compliance. Dashed lines indicated optional components.

One of the required components is the GPS unit. Though it is shown in red for both upgrade paths, some aircraft may not require the installation of a new unit. As long as a pre-existing GPS units meets the performance requirements outlined in the mandate it can be used for ADS-B. As shown in Table 8, 18% of GA had such systems in 2007.

Figure 14 also shows the display as a component of the architecture. A display is not required by the mandate but is needed for the display of ADS-B In information. As mentioned, some displays on GPS units may be usable for this purpose.

As is apparent from the upgrade path on the right in Figure 14, an upgrade from Mode C to UAT ADS-B requires more physical components. In fact, using UAT ADS-B, an aircraft will carry a Mode C transponder in addition to an ADS-B transceiver. This would increase aircraft weight and overall avionics complexity. Appendix A shows the architectures shown in Figure 14 in more detail.

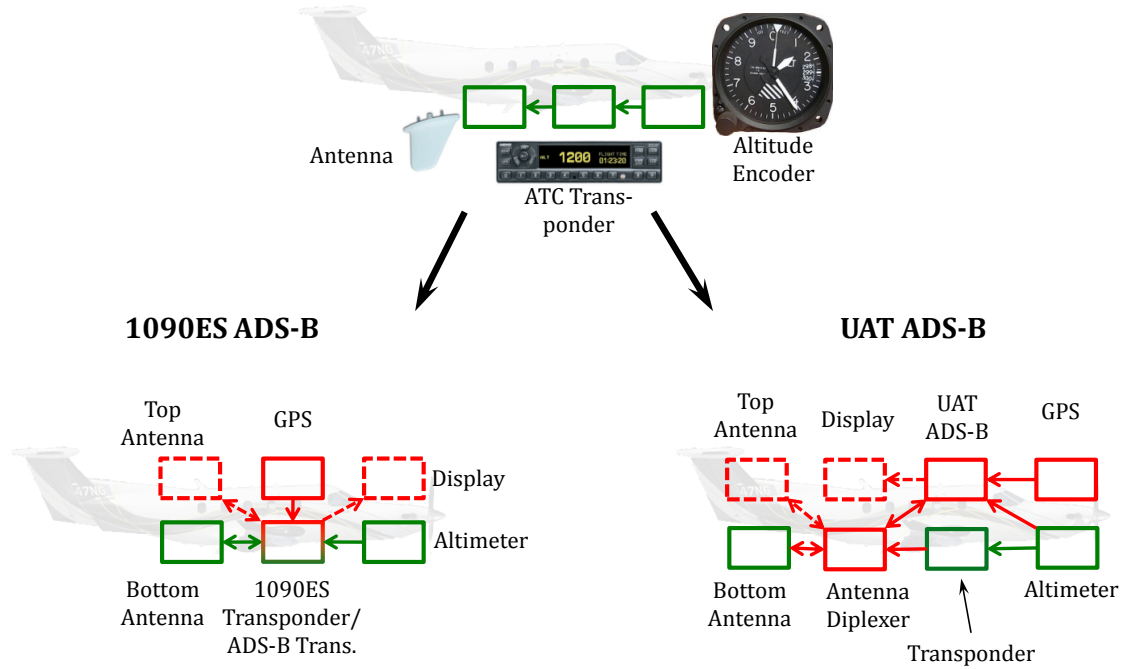

**Figure 14: Upgrade Paths From Currently Required Equipment to UAT and 1090ES.**

### 3.6 Certification of ADS-B Avionics Installations

As discussed, some of the early implementations of ADS-B installations had encoded the ADS-B transmissions incorrectly. In 2010, the FAA required any future ADS-B avionics installation to be certified via a Type Certificate (TC), amended Type Certificate (ATC) or Supplemental Type certificate (STC) in accordance with AC20-165. (FAA 2010) This requirement substantially increases the cost of installation for any ADS-B system. This policy appears to be an effort to ensure consistent performance across the various ADS-B installations, and avoid errors as were seen in early ADS-B installations. As industry gains experience with the installation of mandate compliant ADS-B avionics, the FAA expects that field approvals will be granted. (FAA 2010) As such, in the long run, this approach will ensure that the ADS-B messages can be trusted by ground stations for surveillance as well as by other aircraft for ADS-B In applications, ensuring the delivery of the promised benefit.



# Chapter 4

## IDENTIFYING ADS-B USER BENEFITS TO GENERAL AVIATION

A schematic representation of ADS-B as a multi-benefit and multi stakeholder system is shown in Figure 15. Aircraft Equipage, Operating Procedures and the ATC Ground Infrastructure, the three main system elements introduced in Chapter 2, enable ADS-B applications which in turn are the main vehicle by which ADS-B delivers benefit to the various stakeholders. At the same time, the incurred cost depends on the applications the stakeholder desires to perform.

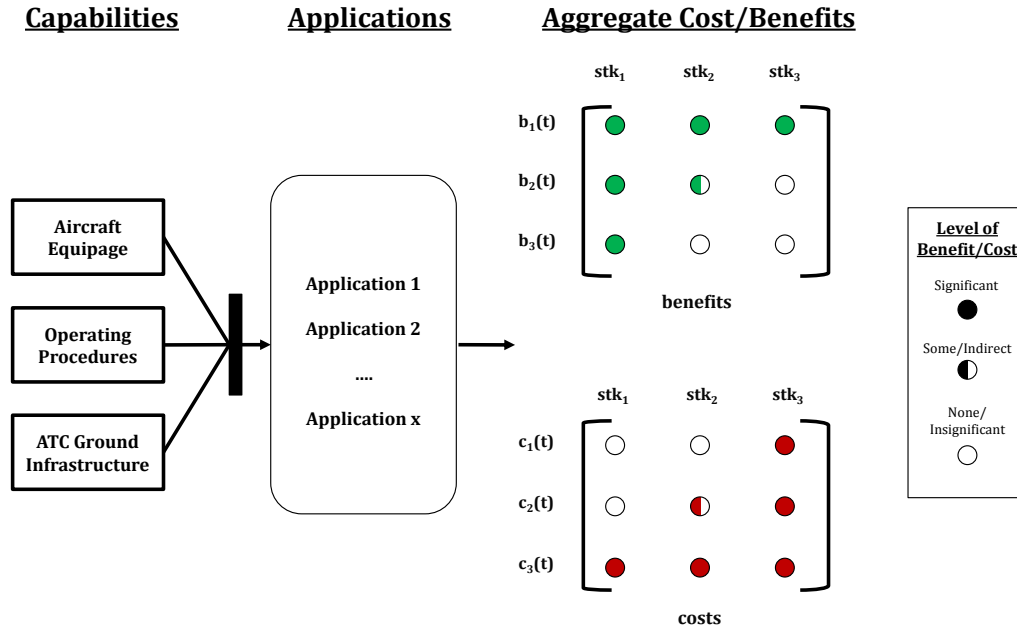

Figure 15: Example Disaggregate Cost Benefit Distribution Modified for ADS-B (adapted from (Marais and Weigel 2007))

Benefits from ADS-B can be separated into multiple categories. Not every stakeholder will receive the same level or type of benefit. Depending on a given stakeholder's operations, some benefits may not be available or not of interest to that stakeholder. For example, in Figure 15, stakeholder 1 receives benefits 1-3 while stakeholder 3 only receives benefit 1. At the same time, not every stakeholder will incur the same costs: stakeholder 1 in Figure 15 only incurs cost 1 while stakeholder 3 incurs costs 1-3. In order to create incentives for stakeholder to equip, care has to be given to balance these cost and benefit matrices for the various stakeholders.

Three significant benefits from ADS-B are Improved Safety, Improved Efficiency and Reduced Infrastructure Cost and Maintenance. These benefits are discussed in section 4.1. Figure 16 shows a notional cost and benefit distribution for those benefit categories. The FAA receives all three benefits while carrying the cost of the ground infrastructure and ATC training. The FAA also sees some indirect cost resulting from avionics certification and standards development. Air Carriers receive the improved safety and efficiency benefits while carrying the cost for avionics upgrades and pilot training. Lastly, GA receives the benefit of improved safety as well as some efficiency benefit while carrying the cost of avionics and training.

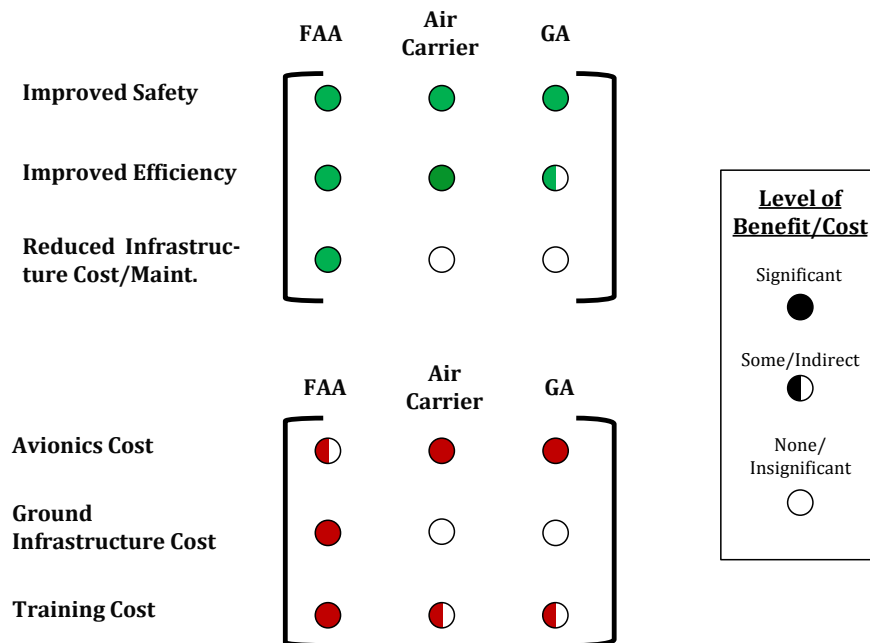

Figure 16: Multi-Stakeholder Cost Benefit Distribution Adopted for the FAA, Air Carrier and GA

## 4.1 ADS-B Benefit Categories

Benefits from ADS-B are enabled by specific applications within the system. The application (e.g. displaying ADS-B traffic to the pilot in the cockpit) enables a direct user benefit, which in turn contributes to the overall system benefit, identified in the following sections. In the example of the traffic display, the direct benefit is improved situation awareness by the pilot, which results in the overall system benefit of increased safety. Conceivably, increased situation awareness could also contribute to an increase in efficiency as flight operations are conducted more accurately. As such, a given ADS-B capability may enable multiple benefits.

For many ADS-B applications, the level of benefit depends on the number of ADS-B equipped aircraft. For example, the more aircraft are transmitting ADS-B, the less ATC has to rely on the existing RADAR infrastructure, allowing the delivery of benefit from ADS-B enabled separation. Also, for ADS-B In applications, the more aircraft transmit ADS-B Out, the more benefit a given ADS-B In application will provide to a user with an ADS-B In equipped aircraft.

Lastly, aircraft only equipped with ADS-B Out also receive some indirect benefit from other aircraft being equipped with ADS-B In. For example, an ADS-B In equipped aircraft has a reduced possibility of a mid-air collision with any ADS-B Out equipped aircraft in its vicinity – this same reduced probability benefits the aircraft only equipped with ADS-B Out.

### 4.1.1 IMPROVED SAFETY

ADS-B has the potential to increase Safety in the National Airspace System. Mechanisms by which ADS-B may increase Safety include:

1. **TIS-B and FIS-B:** Providing free access to weather and NAS status information is expected to aid flight crews in decision making and thus reduce weather related accidents or airspace violations. User surveys have identified these two applications to provide significant benefit to a majority of users
2. **Situation Awareness:** Providing flight crews and controllers a more accurate traffic picture is expected to reduce the number of mid-air collisions as well as reduce airport surface incidents and accidents. In very high density operations like uncontrolled GA airports, increasing traffic situation awareness may result in a significant reduction of the possibility of a mid-air collision.
3. **Data Quality/Availability:** ADS-B has the capability of transmitting information that is currently not available with RADAR. An example would be a filed in the ADS-

B message identifying a downed aircraft. Also, a higher update rate as well as more accurate information can lead to better decision making in case of emergencies.

4. **Workload Sharing:** With the introduction of ADS-B In applications, certain tasks can be transferred from the controller to the pilot. This is expected to result in a more even distribution of tasks, reducing workload induced errors.

#### **4.1.2 IMPROVED EFFICIENCY**

As introduced in section 2.3, most ATC procedures are for operations under Instrument Flying Rules (IFR). The introduction of ADS-B Out based ATC surveillance is expected to provide improvements in efficiency in two ways. First, due to the better quality of surveillance data, current and future procedures may be applied more efficiently where ADS-B surveillance is available. For example, more efficient arrival and departure procedures may reduce overall flight time. Second, providing ADS-B surveillance to airspace that is currently not surveilled by RADAR allows for the extension of those procedures to that environment. Such airspace is currently controlled via procedural surveillance which is less efficient.

Additionally, the introduction of aircraft-to-aircraft ADS-B In applications is expected to enable functionalities in the National Airspace System that are currently not possible. Such ADS-B In applications have the potential to reduce congestion at airports because of more consistent spacing in arriving aircraft, increased capacity at altitude as a result of reduced separation standards as well as enable the continuation of closely spaced parallel approaches in IFR weather conditions.

It should be noted that the efficiency gains for GA mentioned here are subtly different from those air transport desires. In general, airlines favor improved efficiency in the form of reduced separation standards and arrival and departure procedures over non-RADAR surveillance (Hu 2008). As such, the efficiency gains that airlines seek are specific to operations in high density airspace where GA often seeks efficiency gains in lower density and non-RADAR airspace.

#### **4.1.3 REDUCED INFRASTRUCTURE AND MAINTENANCE COST**

The ADS-B ground infrastructure is expected to be significantly less expensive to install and maintain than the RADAR infrastructure. One manufacturer of ADS-B ground stations quotes a reduction in initial procurement cost of a factor of 10 and a reduction on annual maintenance cost of a factor of 20. (Parry 2005) As such, ADS-B is an attractive alternative to RADAR in locations where large volumes of airspace have to be surveilled but the geography does not allow for the installation of RADAR systems. Some RADARs will be



decommissioned after the introduction of ADS-B while other will be retained as a backup surveillance source.

In Australia, one of the earliest countries to adopt ADS-B, ADS-B surveillance provided a substantial benefit from the increase in surveillance coverage alone. As can be seen in Figure 17 most of the existing RADAR coverage in Australia is along the coast (orange lines). The reduced cost and maintenance requirement of ADS-B allowed for the expansion of surveillance into the Outback in central Australia (yellow lines).

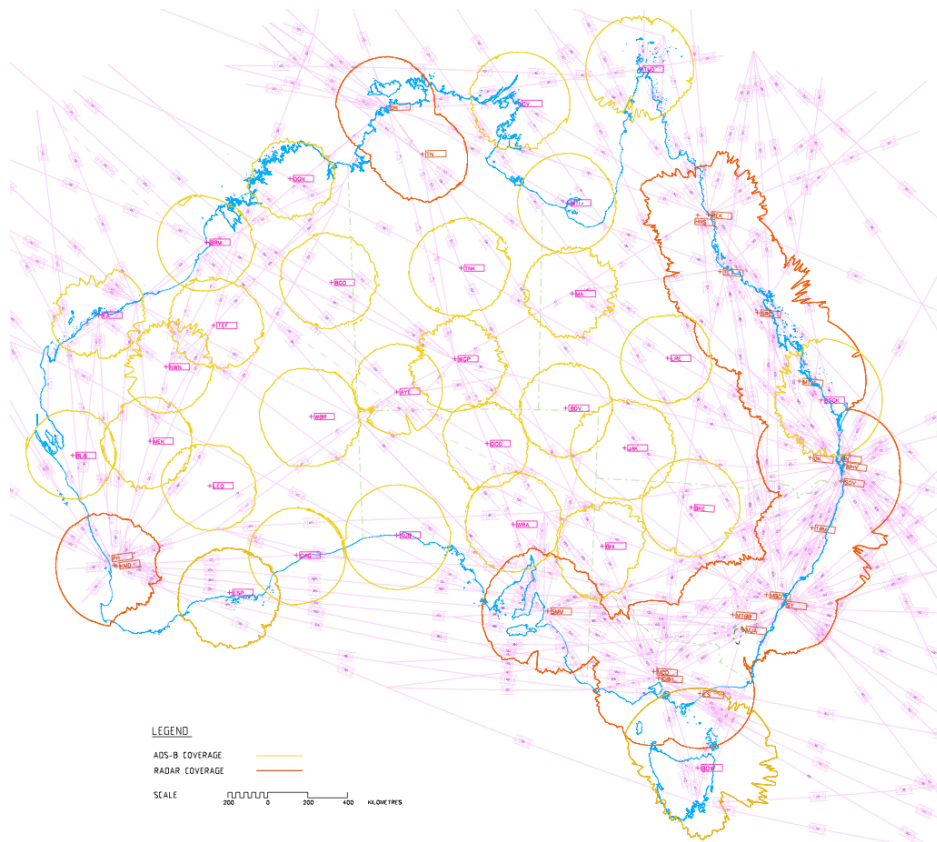

**Figure 17: ADS-B and RADAR Coverage in Australia at 10,000ft AGL (Air Services Australia 2011)**

As shown in depth in Chapter 6, the US has excellent RADAR surveillance. There are very few locations between RADARs that may have localized “holes” of surveillance coverage at low altitudes. The locations that currently have limited surveillance in the US are Alaska, the Gulf of Mexico and some of the mountainous areas in the western US. Since installations of RADAR beacons require precise initial calibration and continual maintenance, the geographical constraints of such locations often prohibit the use of RADARs to provide

surveillance in such areas. Also, such remote locations often are characterized by very limited operations, making it difficult to justify the expense of such a RADAR installation.

With the reduced cost and the low maintenance requirements of the ADS-B ground infrastructure, providing surveillance to such locations may become feasible technologically and financially. In the Gulf of Mexico where a significant amount of helicopter traffic commutes back and forth between land and oil platforms, providing low altitude surveillance is allowing those helicopters to operate in inclement weather. Currently, operations are conducted under VFR because of the lack of surveillance limiting operations to only good weather. As discussed in depth in Chapter 6, providing surveillance will allow the application of standard IFR separation procedures, greatly increasing the efficiency of such IFR operations. In a similar manner, Alaska and mountainous regions are expected to receive ADS-B surveillance in airspace that is currently not RADAR surveilled.

As a result, GA is expected to benefit from this reduction in cost via an increase in surveillance volume. In locations where the cost of RADAR based surveillance has so far not been justifiable, ADS-B based surveillance may become a financially viable option thus expanding the surveillance volume beyond the current RADAR volume. This in turn would allow the expansion of ATC procedures into those areas, removing the requirement of procedural control, increasing efficiency. As a result, for the rest of this thesis, increased efficiency is used as a surrogate for this benefit.

## **4.2 Previous Work on GA User Benefits**

As mentioned in the introduction, concern currently exists about whether or not ADS-B delivers enough benefit to General Aviation. The more the perceived user benefit to GA equals or exceeds the cost of equipping, the more likely GA is to equip with ADS-B early and voluntarily. It is therefore important to identify and implement aspects of ADS-B that generate benefits valuable to GA early on. A thorough understanding of the benefits of ADS-B as well as where ADS-B can deliver benefit to GA is thus required.

Previous work has focused on identifying where ADS-B provides benefit to various users and what ADS-B applications enable such benefit. Two significant contributions are reviewed here.

### **4.2.1 LESTER USER SURVEY AND USER BENEFIT MAPPING (LESTER 2007)**

In 2007, Lester conducted an online survey of 1136 pilots in order to identify where they perceived ADS-B to deliver most benefit. 54% of the surveyed pilots were Part 91

recreational pilots, 19% were Part 91 business (corporate) pilots and 8% were Part 91 flight training pilots. 14.5% were made up of glider pilots, helicopter pilots and commercial pilots other than corporate pilots. 4.5% of the pilots were part 121.

The participants were presented with 21 ADS-B applications and asked to rank the benefit they perceived the application to deliver to them as a pilot. The 21 applications consisted of 11 ADS-B Out, 8 ADS-B In applications, TIS-B and FIS-B. Figure 18 shows the results of the survey.

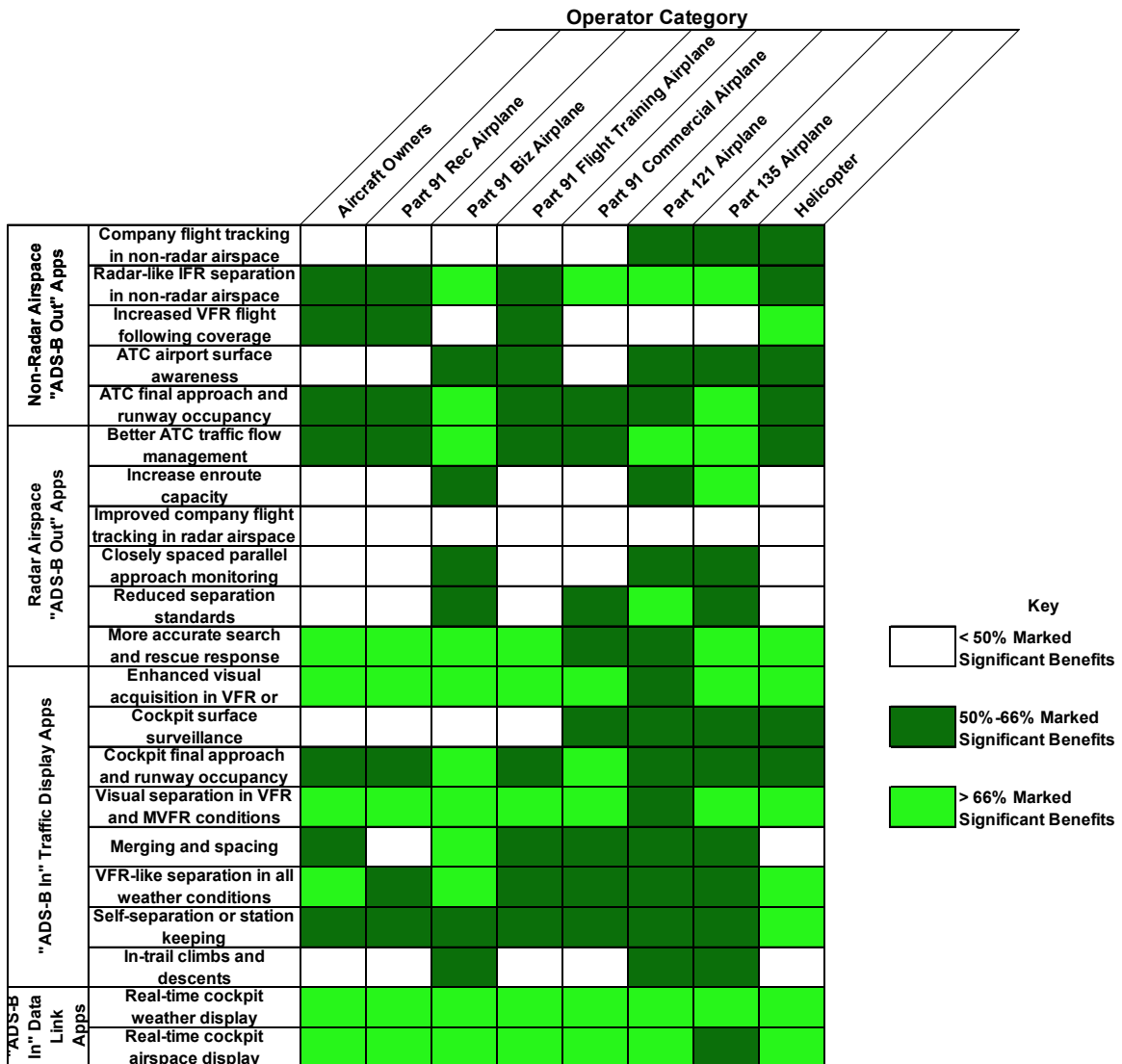

Figure 18: Results From Lester's User Survey

#### **4.2.2 AIWP BENEFIT/APPLICATION RANKING (FAA 2010)**

In 2008, the FAA established a government/industry panel focusing on the identification and definition of ADS-B In applications. This group consisted of members from airlines, airframe and avionics manufacturers, the FAA, the DOD and academia. MIT was one of the members.

The group extensively reviewed proposed ADS-B In applications, identified which ones were unique and created a formal definition for each one. The final deliverable was a document known as the ADS-B Integrated Working Plan (AIWP). It contained the descriptions of 17 unique ADS-B In applications, identified the environments in which those applications would be used, listed alternative technologies, implementation dependencies, previous research as well as future research required.

As part of the analysis, each application was analyzed for how much user benefit they would create for four stakeholders: Air Carrier, High-End GA, Mid/Low-End GA and Military. As is apparent in Table 11, most of the ADS-B In applications in the AIWP are focused on Air Carrier, Military and High-End GA. Mid/Low-End GA is defined as any GA aircraft that is not turbine powered. According to the FAA 2007 Avionics survey, 2.9% of GA aircraft are turbine powered. As can be seen, applications that are labeled as delivering benefit to Mid/Low-End GA are all applications that improve Situation Awareness: with and without alerting, airborne, for visual approach and on the airport surface.

**Table 11: The 17 AIWP ADS-B Applications Identifying What Stakeholders Are Expected To Receive Benefit**

Application		Air Carrier <sup>1</sup>	High-End GA <sup>2</sup>	Mid/Low GA <sup>3</sup>	Military <sup>4</sup>
No	Name				
1	Traffic Situation Awareness–Basic	X	X	X	X
2	Traffic Situation Awareness for Visual Approach	X	X	X	X
3	Airport Traffic Situation Awareness	X	X	X	X
4	Airport Traffic Situation Awareness with Indications and Alerts	X	X	X	X
5	Oceanic In-Trail Procedures	X	X		X
6	Flight Deck Based Interval Management –Spacing	X	X		X
7	Traffic Situation Awareness with Alerts		X <sup>5</sup>	X	X <sup>5</sup>
8	Flight Deck Based Interval Management –Delegated Separation	X	X		X
9	Independent Closely Spaced Routes	X	X		X
10	Paired Closely Spaced Parallel Approaches	X	X		X
11	Independent Closely Spaced Parallel Approaches	X	X		X
12	Delegated Separation–Crossing	X	X		X
13	Delegated Separation–Passing	X	X		X
14	Flight Deck Based Interval Management–Delegated Separation with Wake Risk Management	X	X		X
15	ADS-B Integrated Collision Avoidance	X	X <sup>6</sup>		X <sup>6</sup>
16	Flow Corridors	X	X		X
17	Self Separation	X	X		X

### 4.3 High User Benefit Applications for GA

In order to identify those applications that have the potential to bring significant benefit to GA, the Lester and AIWP tables were carefully reviewed. ADS-B Out applications that were identified by more than 50% of survey participants as providing significant benefit to GA are listed in Table 12. Some inconsistencies exist between the application names used in the Lester survey and the names used in this thesis. Based on their descriptions, applications used for the survey were mapped to the applications described in section 2.4. ADS-B In applications that were identified by the AIWP as providing benefit to GA are also listed in Table 12. TSA stands for Traffic Situation Awareness. Results from the AIWP are consistent with the results from Lester’s survey.

**Table 12: ADS-B In and Out High User Benefit Applications for GA**

<b>Benefit Category</b>	<b>High Benefit ADS-B Out Applications</b>	<b>High Benefit ADS-B In Applications</b>	<b>Data Link Applications</b>
<b>Improved Safety</b>	Improved Search and Rescue	Airport TSA	Traffic Information Service – Broadcast (TIS-B)
		Airport TSA with Indications and Alerts	
	ADS-B Flight Following	TSA – Basic	Flight Information Service – Broadcast (FIS-B)
	TSA – Visual Approach		
		TSA with Alerts	
<b>Improved Efficiency</b>	ATC Surveillance in Non-RADAR Airspace (ADS-B-NRA)		

A recent study of the Soaring community by Hansman and Kunzi shown in Appendix C is also consistent with the results shown in Table 12. User benefits from the identified applications are discussed in the next three sections.

**4.3.1 SAFETY IMPROVEMENTS FROM DATA LINK APPLICATIONS**

TIS-B and FIS-B improve safety by enhancing the situation awareness of the flight crew. As identified by one study of NTSB accident reports, weather related accidents made up 21% of accidents in between 1994 and 2003. (NASDAC 2004) TIS-B and FIS-B are expected to be a significant equipage incentives for GA. In fact, GA user surveys have repeatedly ranked these applications as providing significant benefit. (Lester 2007) (Kunzi and Hansman 2011)

TIS-B and FIS-B are considered essential services and solely advisory to the pilot. Neither of them requires certification or specific operating procedures and thus have minimal barriers for the delivery of benefit. They are therefore omitted in the following barriers analysis.

**4.3.2 APPLICATIONS THAT IMPROVE SAFETY**

The ADS-B Out applications that are expected to improve safety are Improved Search and Rescue and ADS-B Flight Following. The mechanism by which ADS-B Out is expected to improve safety is the same for both applications. ADS-B provides ATC with more accurate and timely data enabling controllers to provide better services to aircraft for flight following. Also, in case of an emergency, this better data potentially allows for quicker and more accurate response. As such, the procedures currently used for flight following and search and rescue would remain unchanged but could be applied more efficiently. Appendix

B describes in more detail the Search and Rescue process used by ATC when an aircraft goes missing or is overdue.

All five ADS-B In applications listed in Table 12 are applications that improve Traffic Situation Awareness – on the ground as well as in the air. This stands to reason as much of GA often flies in high density, VFR environments and lands at busy, uncontrolled airports. As a result, the improved situation awareness is expected to significantly improve safety for General Aviation

Chapter 5 focuses on Airborne TSA. The Traffic Airport TSA application in its basic form as well as with Indications and Alerts has recently been developed by a joint FAA/Industry team. Though the Airport TSA application has the possibility to increase safety in GA, it may not be adopted widely in the near term. During the development of the application, it was discovered that the main driver in the accuracy requirements is the taxiway/runway geometry – distances between the taxiways and runways need to be greater than the accuracy that the navigation system can provide. If the accuracy value is less than the distance, it would not be possible to reliably determine whether the aircraft is on the taxiway or the runway. As a result, smaller airports require higher accuracy navigation units. These navigation units would be required to continuously and reliably provide NACp values of 9, 10 or above as compared to the required NACp of 8. Such avionics are more expensive than the avionics described in section 3.1, and, with the cost sensitivity of GA, are not expected to be used widely in the near term. In the future, however, that with the advent of multi-frequency GPS receivers NACp values above 10 will become more common in lower end GPS avionics.

### **4.3.3 APPLICATIONS THAT INCREASE EFFICIENCY**

ATC Surveillance in Non-RADAR Airspace (ADS-B-NRA) was identified as a high user benefit application for GA. It is expected to improve efficiency in non-RADAR airspace.

As mentioned in Chapter 4, ADS-B surveillance in the Outback of Australia provided a substantial benefit from the increase in surveillance coverage alone. When ADS-B was first considered for the United States (US), surveillance of non-RADAR airspace was expected to be a major benefit and thus be an equipage incentive for General Aviation. Though the US did not have large areas of non-surveilled airspace such as the Australian Outback, some airspace in mountainous and remote areas is below existing RADAR surveillance. An aircraft would have to climb to significant heights before entering into airspace where it can be “seen” by RADAR. As opposed to Australia, therefore, over the contiguous US non-RADAR airspace is generally below rather than outside of RADAR coverage. Figure 19 shows the predicted ADS-B surveillance coverage for the US.

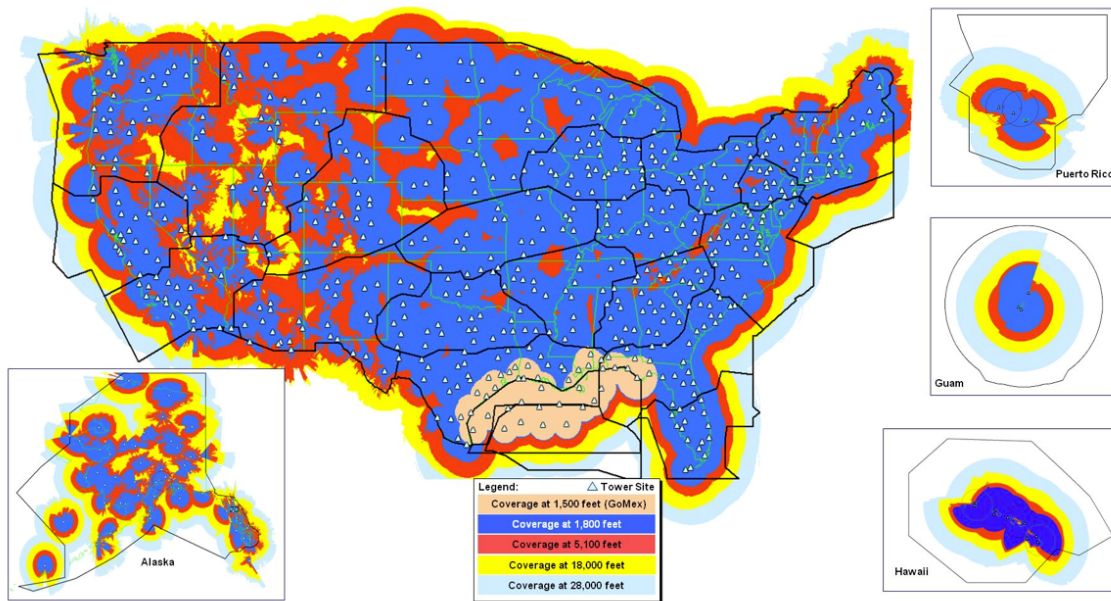

**Figure 19: Predicted ADS-B Surveillance Coverage for the United States**

For a given flight, departure and arrival are the flight phases that are most likely to be at low altitude and thus outside of RADAR coverage. Introducing ADS-B surveillance to airports that are currently in non-RADAR airspace has thus the potential of increasing the access to such airports as well as improving the efficiency of procedures that are being used in those locations. In fact, when the ADS-B Out mandate was first proposed, the FAA mentioned surveillance in non-RADAR areas as a solution to some of the inefficiencies of today’s procedures:

*“Presently ATC controls IFR operations in non-radar airspace using inefficient separation techniques and is unable to provide many advisory services otherwise available in a surveillance environment. Consequently, non-radar separation between aircraft in a non-radar environment within the domestic U.S. is up to 10 minutes (80 miles for jet traffic) compared to 3 or 5 miles in a radar environment. Operators would realize significant efficiency gains, if ATC were able to utilize traffic monitoring techniques currently only available in a [RADAR] surveillance environment (e.g., aircraft vectoring and speed control).”*  
 (FAA 2007)

With ADS-B providing surveillance in non-RADAR airspace, aircraft would be allowed to operate in closer proximity thus increasing airspace capacity and access. Also, ATC



procedures become more efficient. Since GA often operates in such airspace, providing surveillance to aircraft in non-RADAR airspace provides benefit to users as it allows the application of ATC procedures under ADS-B surveillance in non-RADAR airspace.

It should be noted that this increase in procedural efficiency will mostly benefit IFR operations. In fact, ATC is not required to provide separation services to VFR traffic but may do so if the workload permits. Nonetheless, in high density, ATC controlled environments (such as airports) efficiency gains are also expected for VFR operations.

Chapter 6 evaluates the low altitude surveillance across the contiguous United States as well as the procedures that are currently used to separate aircraft in non-surveilled airspace.

#### **4.4 Conclusion**

The ADS-B In and ADS-B Out applications that are expected to provide high user benefit to General Aviation are listed in Table 12. The benefit from those applications is expected to be a major equipage incentive to General Aviation. The following chapters specifically evaluate ADS-B Traffic Situation Awareness and ADS-B Surveillance in non-RADAR airspace in order to identify where most benefit is available for those applications. If applicable, barriers are identified that could prevent the delivery of such benefit.



# Chapter 5

## IDENTIFICATION OF HIGH BENEFIT ENVIRONMENTS

### FOR TRAFFIC SITUATION AWARENESS APPLICATIONS

The Traffic Situation Awareness Application enhances safety by reducing the probability of a mid-air collision. In order to identify where the risk for a mid-air collision (MAC) is highest and thus to identify where Airborne Traffic Situation Awareness would be most beneficial, an analysis on where aircraft most often encounter each other in flight was conducted.

#### 5.1 Mid-Air Collision Analysis: NTSB Accident Reports

National Transportation Security Board (NTSB) mid-air collision accident reports from January 2000 until June 2010 were analyzed. Reports of accidents outside of the US as well as balloon accidents that occurred during that time period were excluded. This resulted in a total of 112 accident reports. The reports did not contain any mid-air collisions involving an aircraft operating under Part 121.

The narrative of each of the 112 reports was reviewed. For each mid-air collision the horizontal encounter geometry was reconstructed. The description of aircraft heading differed between reports (see Table 13): some reports gave exact headings, others used cardinal directions (North, Southwest, etc.) and other yet only gave descriptions of the relative location of the aircraft with respect to each other. Some reports did not have any RADAR data or eyewitnesses available and thus did not have track information at all. To allow for the comparison of the horizontal encounter geometries, the accidents were grouped into bins of 45° based on flight track intersection angle. The 5 groups were centered on the 5 cardinal directions of one half of a compass rose (see Figure 21). In addition to geometry reconstruction, external factors that contributed to the collision were identified (such as the absence or malfunction of equipment).

**Table 13: Format of Heading Information in NTSB Mid-Air Collision Reports**

Description of Heading	Percentage
Cardinal Directions	19%
Exact RADAR Data	12%
No RADAR Data	7%
Implied from description on report	63%

The description of vertical motion of the aircraft was much less consistent. Many reports never mention vertical movement while others simply state that the aircraft was climbing or descending. In many cases, however, it was possible to extract at least the relative vertical motion of the two aircraft based on the narratives.

Accidents were separated into three categories based on their proximity to the airport (Figure 20). As can be seen, the airport environment is where mid-air collisions are most often reported (59%). This implies a requirement that any Traffic Situational Awareness Application needs to be operational in the area surrounding an airport.

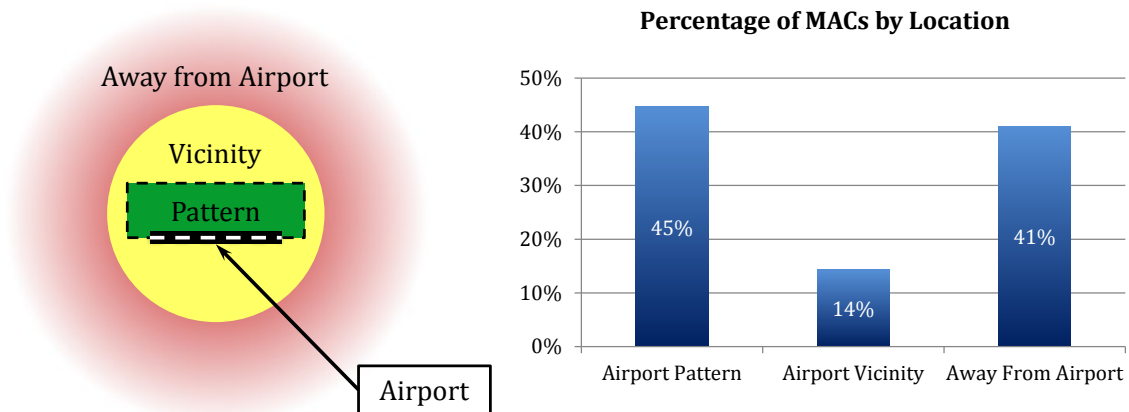

**Figure 20: Percentage of NTSB Mid-Air Collisions by Location**

The intersect angle between the tracks of the two aircraft for all accident reports is summarized in Figure 21. As can be seen, over half (54%) of mid-air collisions happen between aircraft going in generally the same direction.

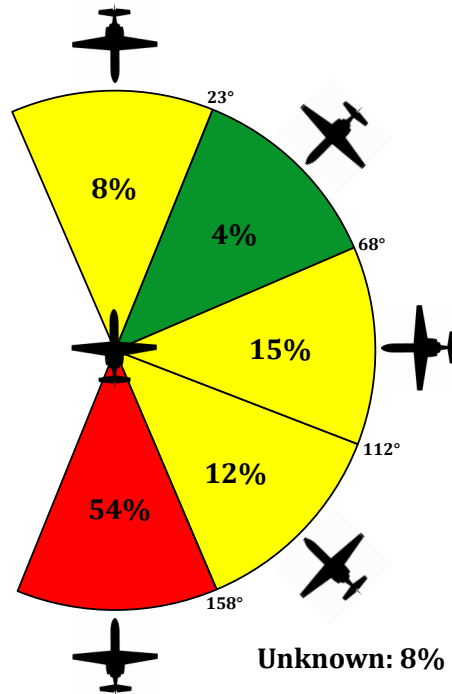

Figure 21: Track Intersect Angle Summarized for All NTSB Mid-Air Collision Reports

To gain a better understanding of the characteristics of encounters based on their location, each of the three environments identified in Figure 20 was analyzed individually.

### 5.1.1 MID-AIR COLLISIONS REPORTED IN THE AIRPORT PATTERN

Out of the 112 reported cases, 50 occurred in the airport pattern. This section analyzes those 50 accidents in more detail. As can be seen in Figure 22, over 80% of the mid-air collisions in the airport pattern happened on final, short final or on the runway. As a result, the track intersection angle most often observed is that of two aircraft going in the same direction. The narratives of these reports paint a similar picture for most of these accidents: two aircraft in approach to the same runway settling into each other as they get closer to the runway. This type of encounter is characterized by a rather small relative velocity which often results in the two aircraft only “bumping” each other. In fact, 31 of the 50 accidents in the airport pattern were non-fatal.

Out of the 50 accidents, nine (18%) involved at least one aircraft that didn’t have a radio. According to the 2007 FAA Avionics Survey<sup>5</sup>, only 2% of the GA fleet did not have a radio installed. six accidents (12%) involved at least one agricultural aircraft. According to the FAA Avionics Survey, 5% of GA hours flown are flown by agricultural aircraft.

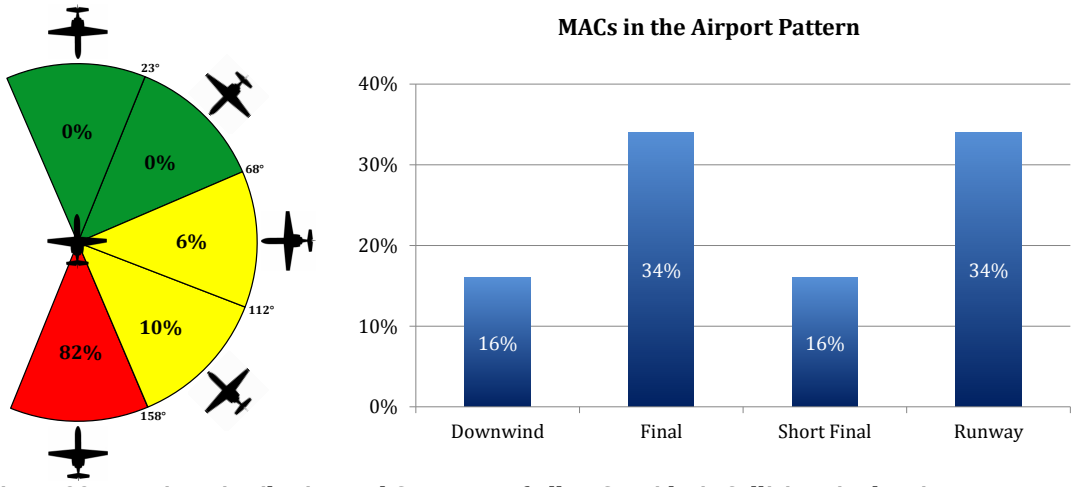

Figure 22: Location Distribution and Geometry of All NTSB Mid-Air Collisions in the Airport Pattern

### 5.1.2 MID-AIR COLLISIONS REPORTED IN THE AIRPORT VICINITY

A total of 16 accidents happened in the airport vicinity. nine of those 16 were between aircraft that had identical flight phases, i. e. both aircraft were departing or arriving at the airport. three accidents happened inside the bounds of the airport pattern but the aircraft were not actually flying the pattern. Specifically, one collision was during a race, one during parachute operations and one during practice for an airshow above the airport. The last four accidents involved one aircraft that was arriving to or departing from an airport and another aircraft on cruise or in maneuvers around that same airport. Figure 23 shows the geometry distribution for the accidents reported in the airport vicinity.

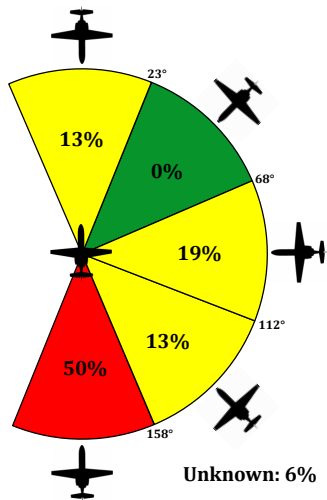

Figure 23: Geometry Distribution for Encounters in the Vicinity of the Airport

### 5.1.3 MID-AIR COLLISIONS REPORTED AWAY FROM THE AIRPORT

A total of 46 accidents occurred away from the airport. The accidents included aircraft that were in cruise as well as aircraft engaging in flight training, surveying, firefighting, EMS transport, aerial application or news reporting (all referred to as “Maneuvering” in Figure 24).

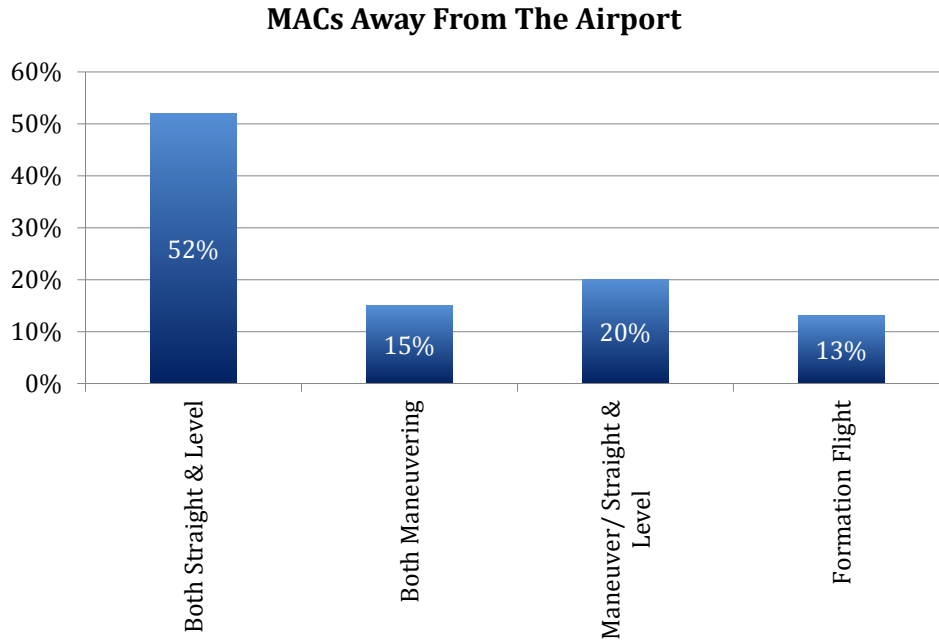

Figure 24: Flight Phases of Mid-Air Collisions Away From the Airport

As Figure 24 shows, out of the 46 accidents, 24 (52%) happened between two aircraft that were both in straight and level cruise. Thirteen (28%) accidents involved at least one aircraft conducting maneuvers such surveying, firefighting or flight instruction. The last nine accidents happened between two aircraft flying in formation.

29% of the accidents occurred between aircraft with generally perpendicular flight tracks. A recurring theme in the narratives (six cases) was that witnesses or survivors mention sun glare as a contributing factor. No collisions were observed where both aircraft were operating under IFR.

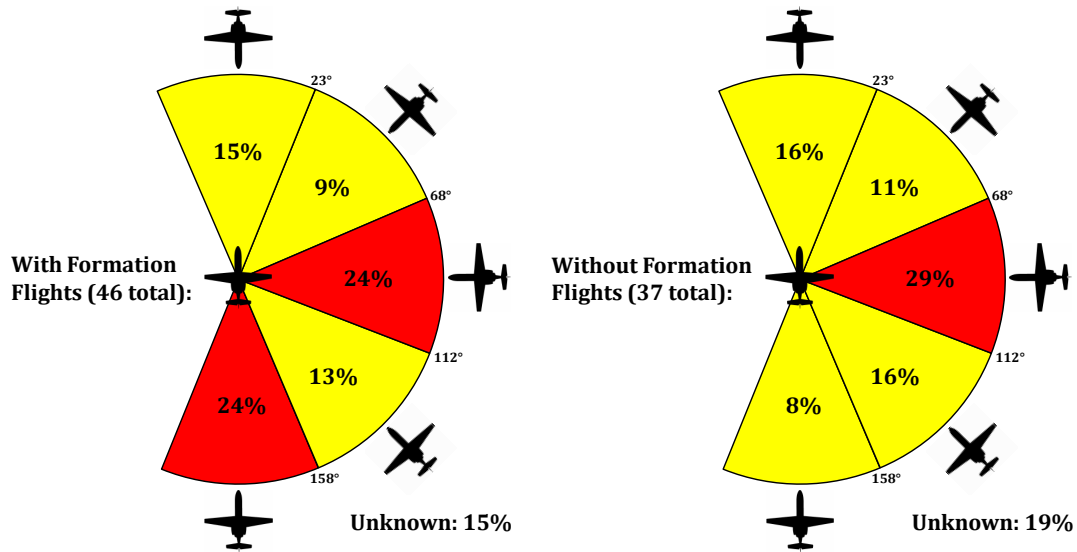

Figure 25: Track Intersect Angle for Mid-Air Collisions Away From the Airport With and Without Formation Flights

## 5.2 Near Mid-Air Collision Analysis: ASRS and NMACS Databases

To further evaluate where an ADS-B based Traffic Situation Awareness system could bring benefit, the Aviation Safety Reporting System (ASRS) and Near Mid-Air Collision System (NMACS) databases were searched for every event classified as a near mid-air collision (NMAC) during the same time period used for the NTSB report analysis. The ASRS database yielded 2,059 results and the NMACs database yielded 1,527 results. The reports in the ASRS database contain a set of fields that the individual creating the report fills in as well as a narrative of the event. The reports in the NMACS database contain a similar set of data fields but do not have a narrative.

The data fields were analyzed for the frequency in which a given characteristic appeared. For example, the reported flight phases of the own-ship were plotted versus the reported flight phases of the intruder aircraft.

Since the aforementioned databases are voluntary reporting systems, care needs to be taken when interpreting the results. Filing an ASRS report gives the reporter certain







observed in the near miss data. A secondary analysis of GA/Part 121 encounters was thus conducted in order to understand the nature of this interaction. Aircraft operating under Parts 91, 135, 137 and 141 were all considered general aviation.

**Table 15: NMAC Encounters by FAR, Ranked by Percentage**

ASRS Database		NMACS Database	
Interaction	Percentage	Interaction	Percentage
GA/GA	44%	GA/GA	28%
GA/Part 121	14%	GA/Part 121	14%
Part 121/Part 121	5%	GA/Military	8%
At least one aircraft unknown	36%	Part 121/Part 121	3%
		At least one aircraft unknown	47%

The flight phases of the GA/Part 121 encounters were analyzed in more detail and are shown in Figure 28. The largest interaction was observed in the ASRS database between a Part 121 aircraft on “Initial Approach” and a GA aircraft on “Cruise”. In fact, the data indicates that the encounters are most likely when the GA aircraft is in cruise and the Part 121 aircraft is in any other flight phase, specifically climbing or descending. This stands to reason as Part 121 aircraft transition through the altitude layers where GA aircraft would be cruising. Also shown in Figure 28 is the altitude distribution where the encounters took place. Again, encounters were most often reported at altitudes that are typical for GA cruising altitudes.

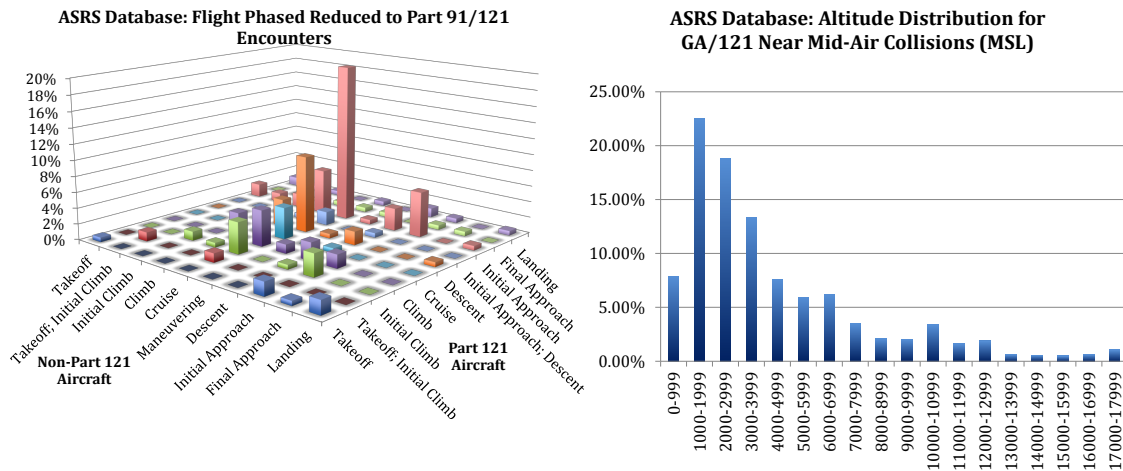

**Figure 28: Flight Phase And Altitude Distribution of GA/Part 121 Encounters in the ASRS Database**

Figure 29 shows the same analysis using NMACS data. Here, encounters while both aircraft were on approach to an airport were most often reported. The encounter between cruising/transitioning aircraft observed in the ASRS data is not as pronounced but can still be observed. The altitude distribution of the NMACS reports shows a distinct second peak around 10,000ft MSL. Upon reviewing the narratives, the low level peak is mostly from VFR traffic while the mid-altitude peak is from cruising IFR traffic as well as sailplanes.

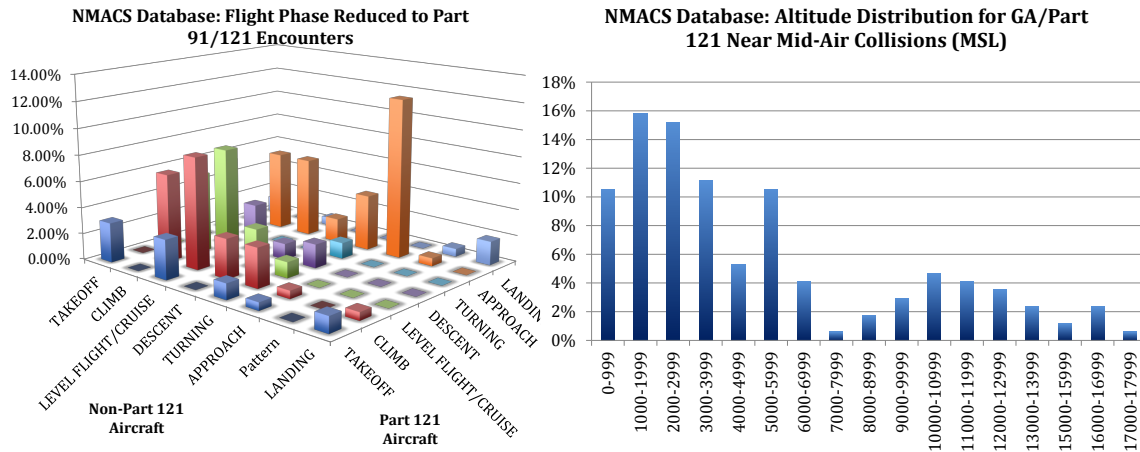

Figure 29: Flight Phase And Altitude Distribution of GA/Part 121 Encounters in the NMACS Database

### 5.3 Conclusion: ADS-B Based Traffic Situation Awareness Brings Major Benefit to GA

In summary, the airport environment is the location where most mid-air collisions occurred (59%) and where the most near mid-air collisions were reported (ASRS, 67%). Encounters between Part 121 and GA aircraft were most often reported to occur between GA aircraft cruising at a constant altitude and Part 121 aircraft that are transitioning through that same altitude. These interactions are most often observed in two distinct altitude layers: low altitude (1000 feet to 4000 feet MSL) and mid-level (9,000 feet to 13,000 feet MSL).

A system that is to provide ADS-B based Traffic Situation Awareness would therefore have to be operational in the airport environment. One major challenge in designing such systems is that the airport environment is a high-density environment with aircraft performing frequent and abrupt maneuvers. In fact, most currently available systems such

as TAS or TCAS (transponder based) are of limited usefulness in the airport vicinity because of their high false alarm rate in high-density environments.

ADS-B's position information is much more accurate than that based on transponders – as a result, it is expected that ADS-B will enable reliable traffic alerting in the terminal area of an airport and even in the airport pattern. This ability has the potential to provide a substantial benefit to General Aviation. ADS-B based traffic alerting would therefore provide significant benefit and an incentive for GA to equip with ADS-B avionics.



## **Chapter 6**

# **IDENTIFICATION OF HIGH BENEFIT LOCATIONS FOR ADS-B LOW ALTITUDE SURVEILLANCE**

In order to understand how ADS-B low altitude surveillance can increase the efficiency of RADAR procedures used to separate aircraft, a thorough understanding of how aircraft separation is accomplished today is required.

If ATC is providing separation services to an aircraft, that aircraft is said to be under “positive control.” For ATC to provide positive control to an aircraft, the aircraft has to be RADAR identified and in radio contact with ATC. Positive control is distinct from procedural control where separation services are provided by the use of procedures rather than based on a RADAR image.

Under positive control, ground based RADAR antennas interrogate transponders onboard aircraft. Those transponders respond to that interrogation with the information corresponding to the mode of the transponder (refer to Table 10). This RADAR return is used to display the location of aircraft to ATC. ATC then uses voice commands to direct and separate aircraft.

When ATC does not have a RADAR image available, ATC uses procedural control to provide separation. If the airspace at a given airport is under procedural control, only one aircraft is allowed to enter that airspace at a time. For example, if multiple IFR aircraft approach an airport that does not have RADAR coverage to the surface, all aircraft are required to enter into a holding pattern while still in RADAR coverage. ATC then releases one aircraft at a time into the airspace – the other aircraft remain in the pattern until the released aircraft closes its IFR flight plan or is reported in sight by the airport tower. Along the way, the controller responsible for coordinating approaching aircraft will transfer the aircraft to the controller in the ATC Tower at the airport where the aircraft intends to land. This tower controller will then guide the aircraft the rest of the way to the surface. If a pilot so desires,

and the weather allows it, the IFR flight plan can be closed ahead of time while still in flight. If an IFR flight plan for an aircraft is closed, ATC is no longer required to apply positive or procedural control to that aircraft and can then release the next aircraft into the non-RADAR volume (refer to Order 7110.65S, section 4-8-1c).

When multiple aircraft approach a non-towered airport, the procedure followed by ATC differs somewhat from that described for towered airports. Aircraft are still required to hold in RADAR coverage while one aircraft at a time is released into the non-surveilled airspace (see Figure 30). However, rather than transferring communications to the local airport tower, the pilot is advised to switch to the Common Traffic Advisory Frequency (CTAF) before reaching the Final Approach Fix (FAF). This in effect terminates direct ATC interaction while the aircraft continues operations on an open IFR flight plan. As such, ATC is still required to separate other aircraft from it and cannot release the next aircraft until that IFR flight plan is closed. Common procedure is that pilots will close their flight plans once they break out of the clouds and an IFR flight plan is no longer required, or by a phone call once they land and cannot reach ATC via radio communications (refer to 7110.65 4-8-8 and 7110.65 4-8-1 c). Figure 30 is a schematic representation of this process. This issue of reduced efficiency during IFR at non-surveilled airports is commonly called “One In, One Out.”

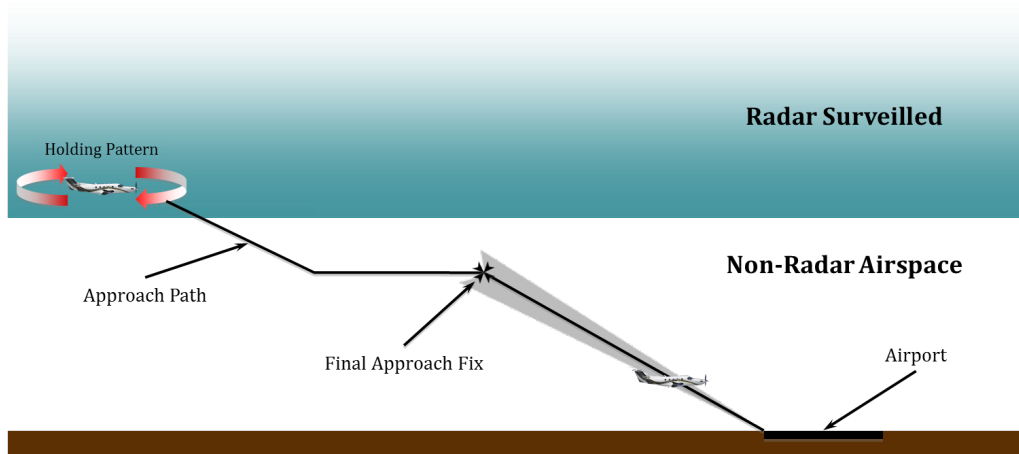

**Figure 30: Schematic Representation of Approach to an Airport Without RADAR Surveillance to the Surface**

As a comparison, using standard separation of two minutes between small aircraft, 30 landings could be expected at a controlled airport with RADAR surveillance. If, however, procedural control is to be used, only one aircraft is allowed on the approach at a time. At



around 15 minutes per approach, the acceptance rate of that airport would drop to four aircraft per hour.

As mentioned, it is expected that ADS-B could provide the missing surveillance in such areas and enable more efficient operations at airports that currently have to use procedural separation during IFR conditions.

## **6.1 Analysis of Existing RADAR Coverage Over the Contiguous United States**

To identify where ADS-B-NRA would be most beneficial, an accurate understanding of the existing RADAR coverage is required. To do so, Enhanced Traffic Management System (ETMS) data from 2005 was analyzed. ETMS data contains RADAR tracks of aircraft along with information about the type of aircraft, origin and destination, airline, speed and aircraft altitude.

Each RADAR track contains longitude and latitude (in minutes) of the aircraft as well as its pressure altitude above Mean Sea Level (MSL). Using a flat earth projection over the US, the final resolution was 1NM by 1NM. With a MATLAB script, each RADAR track was then analyzed and plotted above the US. For each 1NM by 1NM pixel that the track touched, the altitude was extracted and stored. As more and more tracks were analyzed, a given pixel was sooner or later touched again. In that case, the altitude that is the lower one between the two tracks was retained.

Over an entire year, a multitude of aircraft continued to fly over that pixel – some of them at low altitudes. After analyzing the entire years' worth of data, the altitude assigned to a given pixel was the lowest altitude at which an aircraft was observed by any RADAR during that year. Figure 31 shows this lowest track altitude for MSL altitudes.

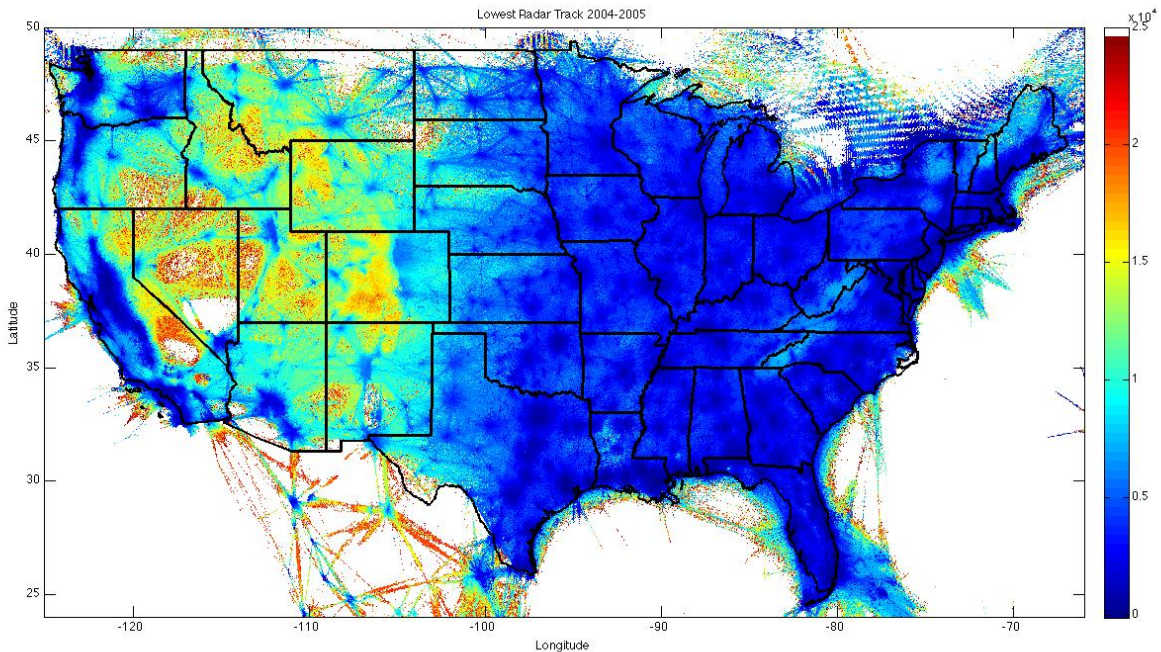

**Figure 31: Altitude of Lowest ETMS Track Over United States in 2004-2005**

As can be seen, the altitudes of the lowest observed RADAR tracks increase from below 500ft on the East Coast and increase in altitude over the Rocky Mountains. Any pixel that is left white had a lowest RADAR track in excess of 25,000ft. In the Rocky Mountains, one can clearly identify the valleys and mountain passages used as traversing routes. Also clearly visible in southern Nevada are Area 51 and Edwards Air Force Base just southwest of it. In the east, the White Mountains and the Smoky Mountains are visible while in the south of South Dakota, the Black Hills can be identified.

To identify where ADS-B surveillance would be most useful, however, airspace where RADAR surveillance is not available needs to be identified. As such, the lowest altitude above ground (AGL) where RADAR surveillance can be provided (“RADAR Floor”) is of interest. This altitude can be used to identify the amount of non-RADAR airspace that exists between the RADAR Floor and the earth’s surface at a given location.

Also, the amount of benefit that ADS-B surveillance at a given airport would create is proportional to the number of yearly operations at that airport. The less the number of

operations, the less the overall benefit. Figure 32 shows the altitude of the lowest RADAR track above ground level (AGL) for airports with more than 10,000 yearly operations.<sup>3</sup>

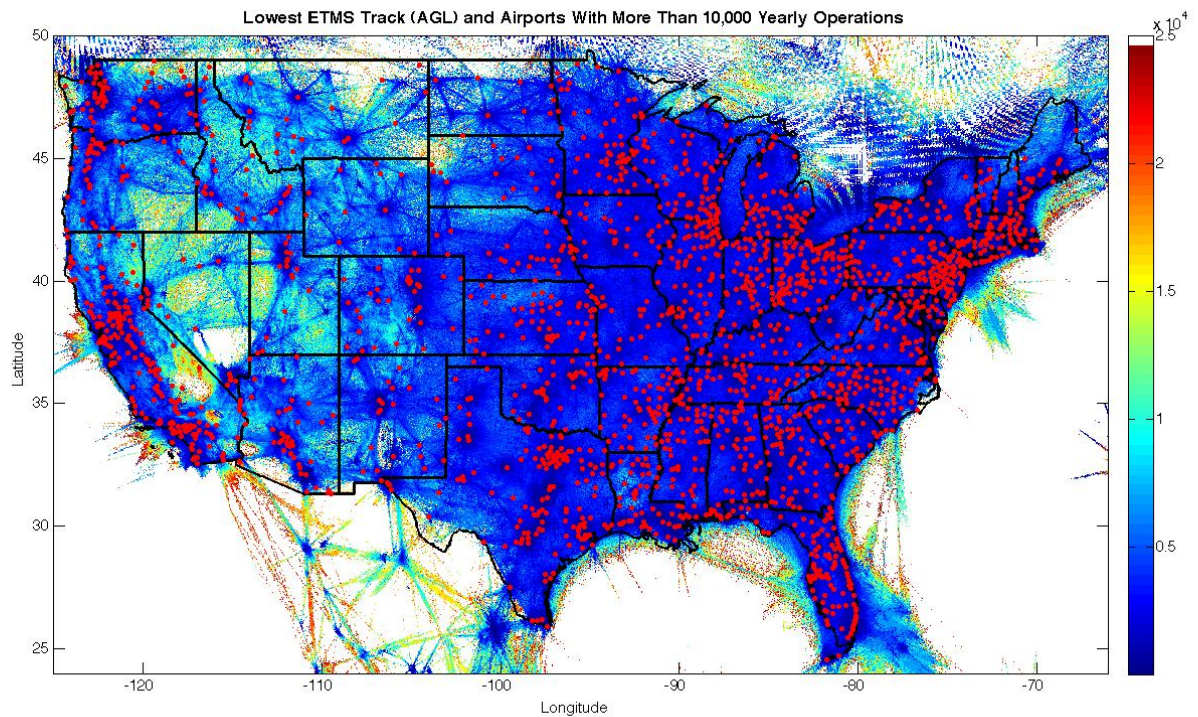

**Figure 32: Altitude of Lowest ETMS Track Above Ground Level Over US in 2004-2005 And Airports With At least 10,000 Yearly Operations**

Again, the eastern seaboard and Midwest have generally low RADAR Floors. One observation that can be made is that airports that have more than 10,000 operations per year generally have very good low altitude surveillance. In fact, it appears that overall the US has outstanding low altitude RADAR surveillance. In the north-central US, it is also apparent that most low altitude traffic follows the victor airways between major cities and airports. In those areas, the RADAR floor off of these airways is most likely lower (better) than indicated by Figure 32.

---

<sup>3</sup> Operations based on FAA Form 5010 data in 2009

## 6.2 Identification of Airports Where ADS-B Surveillance Could Provide Benefit

Since the original FAA ground infrastructure contract with the service provider only requires the ADS-B surveillance coverage to replicate the currently existing RADAR coverage, airports that currently have no RADAR coverage may remain without surveillance coverage. As mentioned however, to increase efficiency at an airport, low altitude surveillance should be extended to lower altitudes. Using the data from the RADAR Floor study, airports that currently have a high RADAR Floor and would thus benefit from ADS-B surveillance were identified. To determine the altitude of the RADAR floor above a given airport, the airport’s elevation was subtracted from the altitude of the lowest ETMS track above that airport.

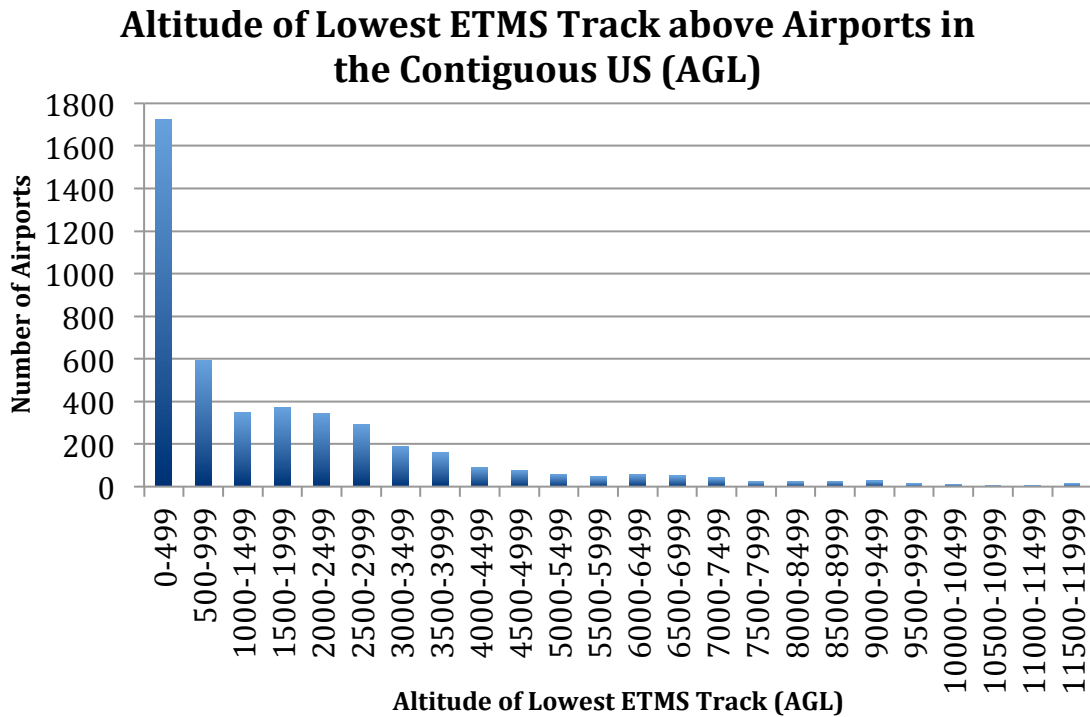

**Figure 33: Altitude Distribution of Lowest ETMS Track Above All Public US Airports (AGL)**

Figure 33 shows the distribution of altitudes for all public airports in the contiguous US. 65 airports with altitudes in excess of 12,000ft are not shown. Again, the amount of benefit from ADS-B surveillance is proportional to the number of yearly operations at that airport. Figure 34 shows the RADAR floor altitude distribution for airports with more than 10,000

yearly operations. As can be observed, a large majority of airports have RADAR service to at least ,1000ft AGL, the typical traffic pattern altitude.

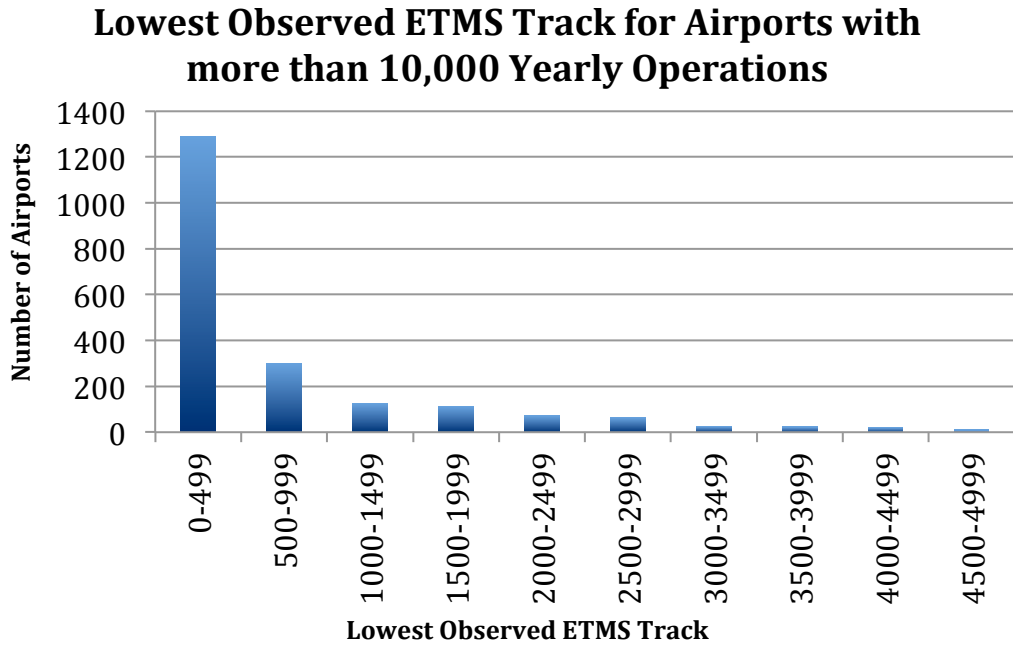
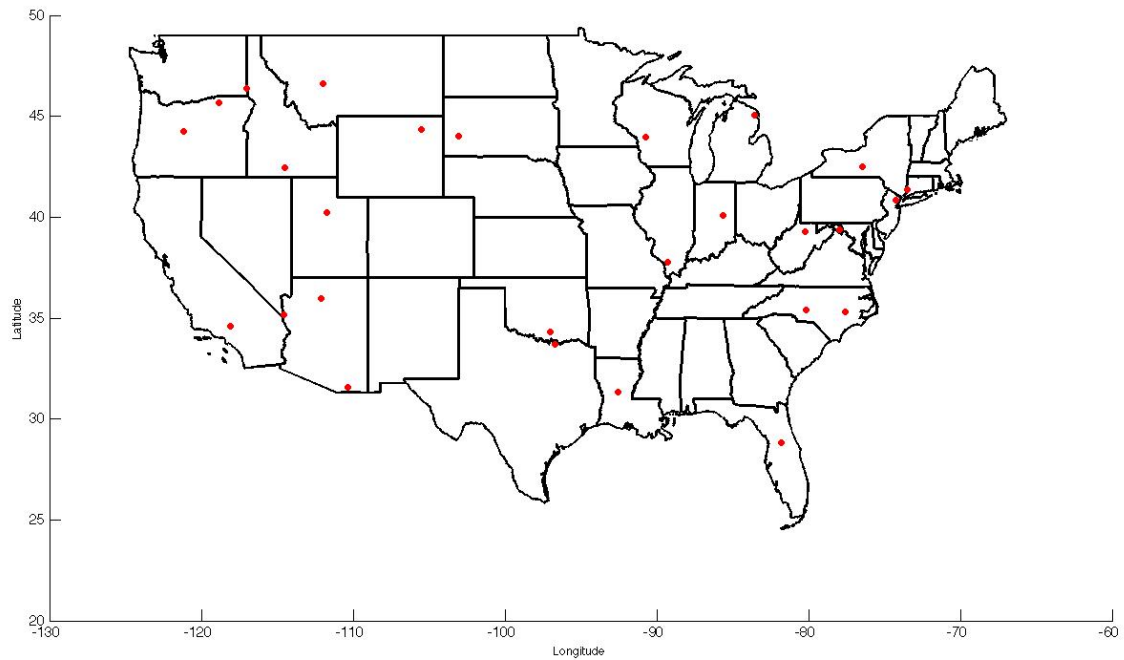

**Figure 34: Altitude Distribution of Lowest ETMS Track Above US Airports (AGL) With More Than 10,000 Yearly Operations**

ATC procedures for IFR approaches into non-RADAR airspace differ based on whether the airport has a control tower. Each case is evaluated separately and the mechanism by which ADS-B NRA would enable the delivery of benefit is identified.

### 6.3 ADS-B Efficiency Benefits at Towered Airports

Figure 35 and Table 16 identify the 27 towered airports with a RADAR floor of 500ft AGL or higher (as of 2005). In conversations with FAA representatives, it has been mentioned that the FAA has since actively been addressing this issue by installing terminal RADAR systems (BI6). As a result, some of those airports now have surveillance to the surface and the number of airports with a surveillance floor in excess of 500ft is less than the 27 identified in Figure 35. An efficiency benefit from low altitude ADS-B surveillance would therefore be localized at those airports.



**Figure 35: Towered Airports With Observed RADAR Floors of More Than 500ft**

**Table 16: Towered Airports With More Than A RADAR Floor Of More Than 500ft (AGL)**

<b>Airport ID</b>	<b>Operations</b>	<b>Lowest ETMS Track</b>	<b>Airport ID</b>	<b>Operations</b>	<b>Lowest ETMS Track</b>
HLN	47686	4723	VUJ	19830	891
PMD	63230	2932	AEX	40681	874
TWF	35123	2746	MRB	52750	735
FHU	138106	2581	LEE	114061	724
PVU	172000	1903	ISO	29095	707
CMY	14200	1763	ITH	47029	701
GCC	22183	1610	AID	26874	681
GCN	102608	1491	MDH	93572	589
LWS	29482	1458	CKB	52489	583
GYI	53300	1451	DXR	83419	542
PDT	25019	1403	ADM	45729	538
RDM	53483	1208	CDW	89522	527
RAP	45237	1021	APN	13259	511
IFP	20161	999			

## 6.4 ADS-B Efficiency Benefits at Non-Towered Airports

Much of GA regularly operates at non-towered airports. As opposed to towered airports, non-towered airports often do not have good low altitude surveillance. Figure 36 identifies non-towered airports that have an observed RADAR floor in excess of 500ft and more than 10,000 yearly operations (a total of 806 airports). As described above, when aircraft approach such an airport, ATC will advise the pilot to switch communication frequencies when approaching the final approach fix (FAF). ATC will then keep the airspace clear until the IFR flight plan of that aircraft has been closed.

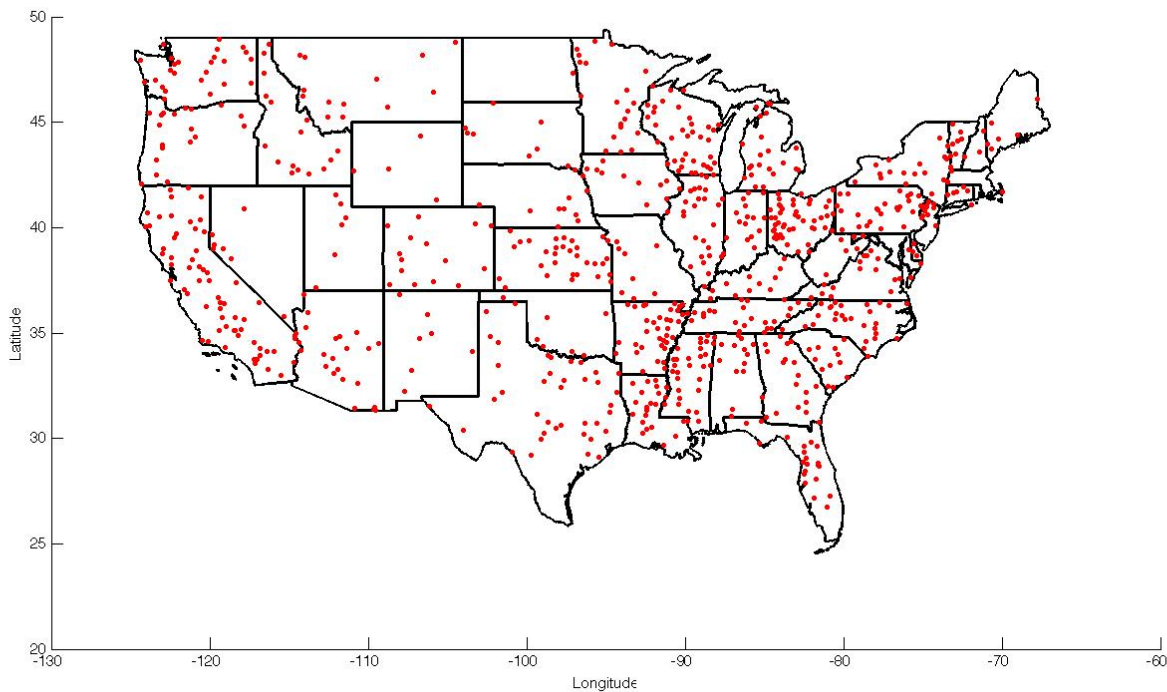

**Figure 36: Non-Towered Airports With More Than 10,000 Yearly Operations and an Observed RADAR Floor Higher Than 500ft AGL**

Without voice communication contact between ATC and the aircraft after the FAF, ATC no longer has positive control. As a result, ATC cannot release the next aircraft into the same airspace until the first aircraft is confirmed to have landed or closes its flight plan. In other words, it's not only the lack of surveillance at low altitudes that currently causes inefficiencies at non-towered airports during IFR but the requirement for aircraft to switch to the airport frequency before the final approach fix. The airspace around the airport remains procedural airspace even though surveillance coverage may be available.

Therefore, providing ADS-B surveillance *below* the altitude of the final approach fix by itself would not alleviate the problem. Additionally, procedures that allow controllers to maintain communications with aircraft approaching non-towered airports would have to be developed.

#### 6.4.1 NON-TOWERED AIRPORTS WITH RADAR FLOORS IN EXCESS OF 1500FT AGL

A subset of non-towered airports may receive an immediate benefit upon installation of ADS-B surveillance, prior to the development of the procedures described in the previous section. As mentioned, if multiple aircraft arrive at a non-towered airport at the same time, the waiting aircraft have to remain within RADAR surveillance. As such, the further the distance between the FAF and the lowest available RADAR surveillance, the more time is required for one aircraft to complete the approach, increasing waiting times for the waiting aircraft. Figure 37 shows the distribution of RADAR floor altitudes of non-towered airports with more than 10,000 yearly operations. 392 airports have RADAR floor higher than 1500 ft AGL – a typical FAF altitude. Appendix E contains a list of those 392 Airports with their respective RADAR floors and yearly operations.

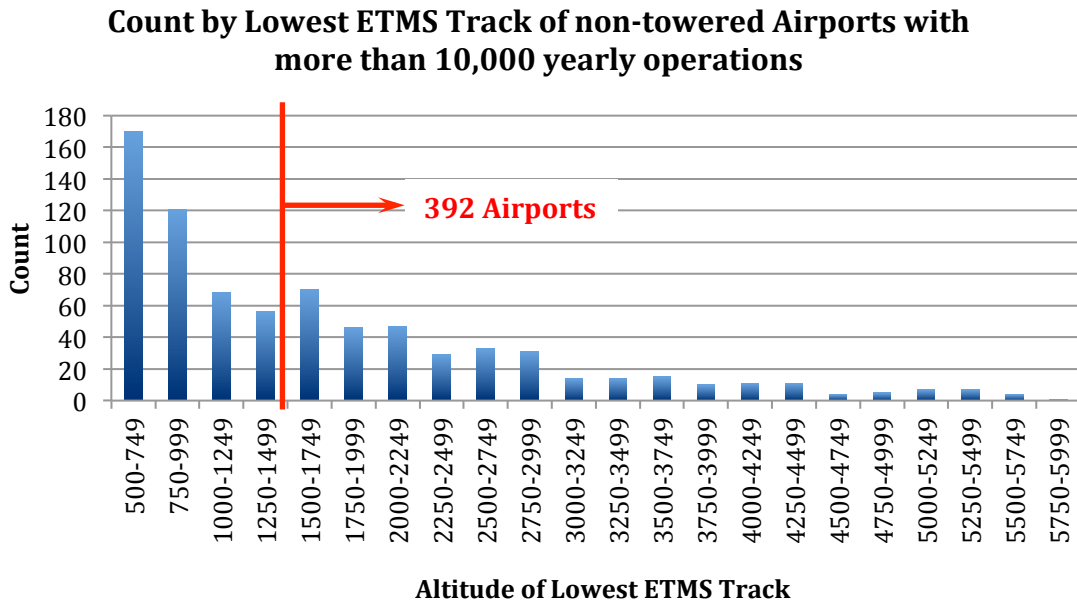

**Figure 37: Number of Non-Towered Airports With More Than 10,000 Yearly Operations Binned by Lowest ETMS Track (32 Airports With RADAR Floors In Excess of 6000ft AGL Are Not Shown)**



Providing ADS-B surveillance to airports where the RADAR floor is much higher than the altitude of the final approach fix will lower the altitude at which aircraft will be required to hold, reducing the time required to complete the approach from the holding pattern to airport. As a result, in this case, ADS-B surveillance by itself can create an efficiency benefit.

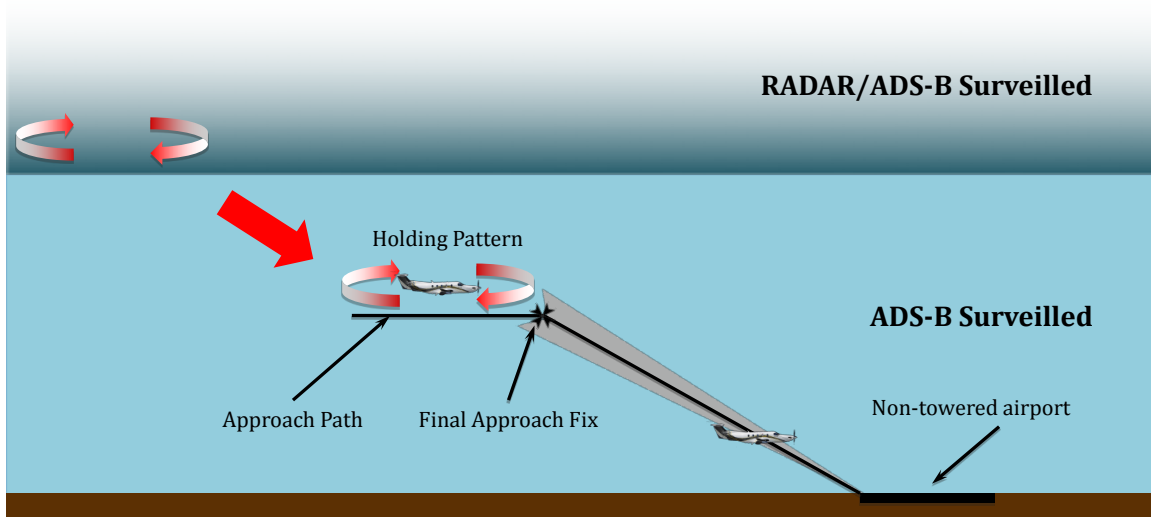

**Figure 38: Schematic Representation of How ADS-B Surveillance Improves Efficiency at Non-Towered Airports During IFR Operations**

A secondary benefit from providing ADS-B surveillance is that radio communications coverage will also be extended. ADS-B ground stations include communications antennae and in order to provide communications in the ADS-B surveillance volume. This will be beneficial in situations where previously there was no communications coverage to the airport surface – rather than having to call ATC via phone, a pilot will be able to inform ATC of the landing (or close the flight plan) sooner, allowing the next aircraft to be released sooner.

As discussed earlier, the contract for the ADS-B ground infrastructure does not currently require ADS-B surveillance to exceed the current RADAR surveillance. As a result it is unclear how many airports will receive a benefit as depicted in Figure 38. The FAA is aware of this issue and has been proactive in identifying airports that could receive an efficiency benefit from placing the ADS-B ground stations in their vicinity.

## **6.5 Conclusion**

Providing low altitude surveillance has the potential to improve efficiency during IFR conditions. 27 towered airports with RADAR floors of more than 500ft have been identified. ADS-B surveillance in those locations would create a significant benefit locally. Non-towered airports without low altitude surveillance are more common (806 total). Providing ADS-B surveillance at non-towered airports is thus where ADS-B low altitude surveillance is most desired.

However, in addition to providing surveillance, additional ATC procedures need to be developed to take advantage of that surveillance. Currently, procedures require aircraft to switch the airports CTAF frequency which requires ATC to apply procedural control which introduces the inefficiencies. The new procedures would allow ATC to remain in radio communication with aircraft operating at non-towered airports, preventing the application of procedural control.

A subset of non-towered airports with RADAR floor altitudes in excess of the final approach fix would receive benefit even without the creation of such procedures. A secondary benefit from providing ADS-B surveillance is that radio communications coverage will also be extended, potentially resulting in more efficient cancellation of IFR flight plans.

# Chapter 7

## SUMMARY AND CONCLUSION

General Aviation (GA) makes up over 96% of all active aircraft in the National Airspace System in the US. Even though the number of GA aircraft vastly outnumbers the number of air carrier aircraft, yearly aircraft utilization is much lower.

In order to create incentives for GA to equip with ADS-B avionics, ADS-B benefits to GA have to be available. It is therefore important to identify and implement aspects of ADS-B that generate benefits valuable to GA early. To identify these aspects, ADS-B applications were evaluated, identifying which user benefits are most valuable to GA. Table 17 shows the applications identified as providing high user benefit to General Aviation. TSA stands for Traffic Situation Awareness.

**Table 17: ADS-B In and Out High User Benefit Applications for GA**

<b>Benefit Category</b>	<b>High Benefit ADS-B Out Applications</b>	<b>High Benefit ADS-B In Applications</b>	<b>Data Link Applications</b>
<b>Improved Safety</b>	Improved Search and Rescue	Airport TSA	Traffic Information Service – Broadcast (TIS-B)
		Airport TSA with Indications and Alerts	
	ADS-B Flight Following	TSA – Basic	Flight Information Service – Broadcast (FIS-B)
		TSA – Visual Approach	
		TSA with Alerts	
<b>Improved Efficiency</b>	ATC Surveillance in Non-RADAR Airspace (ADS-B-NRA)		

To allow for these applications to be used and benefit to be delivered, the applications and their operating procedures have to be developed first. The benefit categories and their respective applications in Table 17 were analyzed as to identify how much benefit is available to GA as well as to what barriers exist that currently limit the delivery of benefit.

ADS-B enabled Traffic Situation Awareness has a significant potential to provide benefit and thus an equipage incentive to GA. Current traffic alerting systems, are least effective in the pattern environment which is where most airborne traffic conflicts occur (59%). The most likely location for a mid-air collision to occur is on Final in the airport pattern (34%). Developing an ADS-B application that has the capability to reliably alert pilots in the pattern to potential traffic conflicts poses a significant incentive to equip with ADS-B. Therefore, the implementation and development efforts for the Airborne Traffic Situation Awareness application should be accelerated.

ADS-B enabled low altitude surveillance also has the potential to provide significant benefit to GA. Low altitude surveillance has the potential to improve the efficiency of existing procedures in locations where currently RADAR surveillance is not available as well as potentially increase access to high density.

Providing low altitude surveillance has the potential to improve efficiency during IFR conditions. 27 towered airports with RADAR floors of more than 500ft have been identified. ADS-B surveillance in those locations would create a significant benefit locally. Non-towered airports without low altitude surveillance are more common (806 total). In order for the delivery of benefit to be possible, however, additional ATC procedures need to be developed in addition to providing surveillance. Currently, procedures require aircraft to switch the airports CTAF frequency which requires ATC to apply procedural control which introduces the inefficiencies. The new procedures would allow ATC to remain in radio communication with aircraft operating at non-towered airports, preventing the application of procedural control.

## Appendix A

### Full List of Required ADS-B Message Elements

Table 18: Minimum Required ADS-B Message Elements and Their Minimum Performance Requirements

ADS-B Message Element	Performance Requirement	Notes
Length and Width of Aircraft	Hardcoded	Only Transmitted on Ground
Latitude and Longitude	See NACp	In reference to WGS84
Barometric Altitude	N/A	In 25ft Increments
Aircraft Velocity	See NACv	In m/s
TCAS Installed	Hardcoded	Yes or No coding
TCAS RA In Progress Flag	N/A	Yes of No coding
ATC Transponder Code	N/A	Entered via same interface as Transponder
Aircraft Call Sign	N/A	Either N-number or Airline Call Sign
Emergency Status	N/A	Flag to indicate Emergency, Radio Failure or Unlawful Interference
IDENT	N/A	Same function as Transponder IDENT
24-bit ICAO aircraft address	Hardcoded	Binary Code Assigned by ICAO
Emitter Category	Hardcoded	Gives indication of type of aircraft
ADS-B In Equipment	Hardcoded	Yes or No coding
Geometric Altitude	N/A	Height above WGS84
NACp (Navigational Accuracy Category for Position)	Less than 0.05NM (NACp=8)	Minimum Required Position Accuracy
NACv (Navigation Accuracy Category for Velocity)	Less than 10m/s (NACv=1)	Minimum Required Velocity Accuracy
NIC (Navigation Integrity Accuracy)	Less than 0.2NM	Minimum required Integrity
SDA (System Design Assurance Parameter)	Hardcoded, at least 2 (10e-5)	Maximum probability of false or misleading data to be transmitted
SIL (Source Integrity Level)	Hardcoded, at least 3 (10e-7)	Maximum probability of exceeding the NIC containment radius



## Appendix B

### Detailed ADS-B Out Avionics Architectures

This appendix shows detailed schematic ADS-B avionics architectures. It also identifies the level of current equipage based on the FAA 2007 Avionics Survey. Part 135 aircraft were included in the equipage percentages.

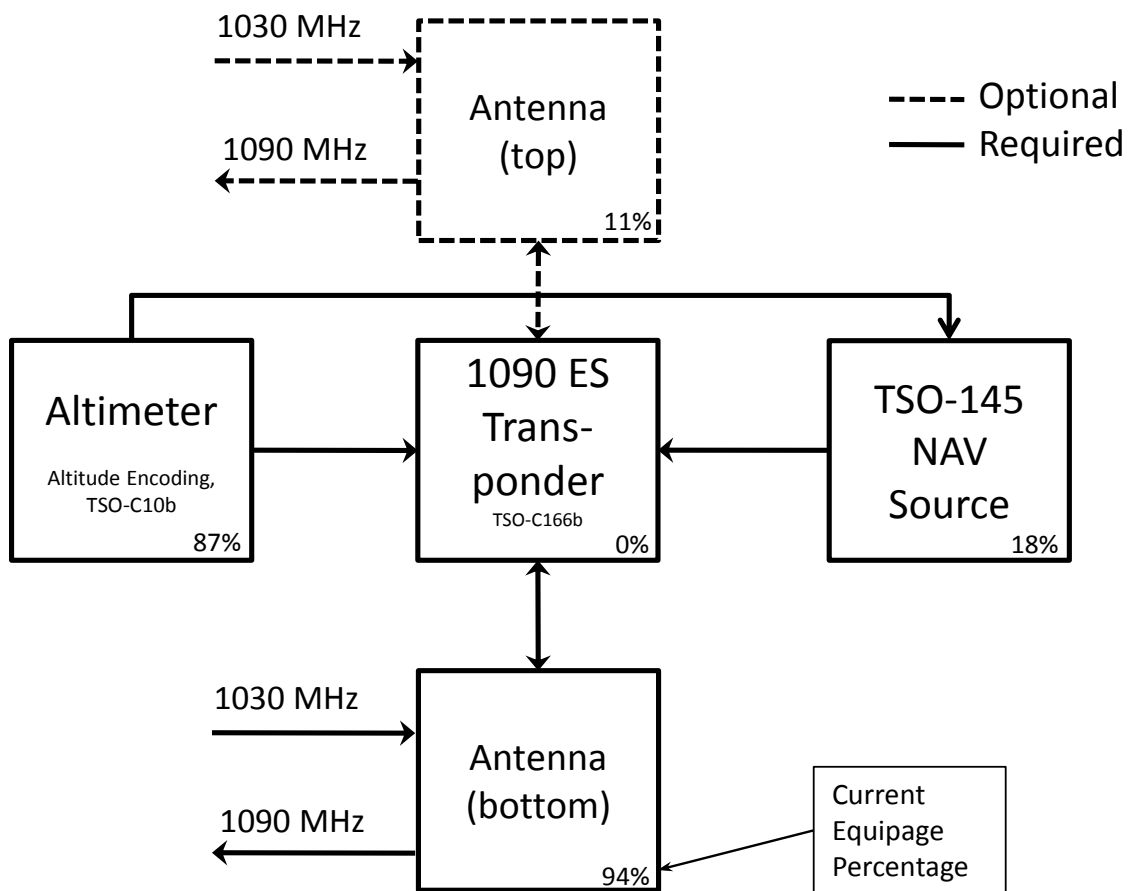

Figure 39: Detailed 1090ES ADS-B Avionics Architecture

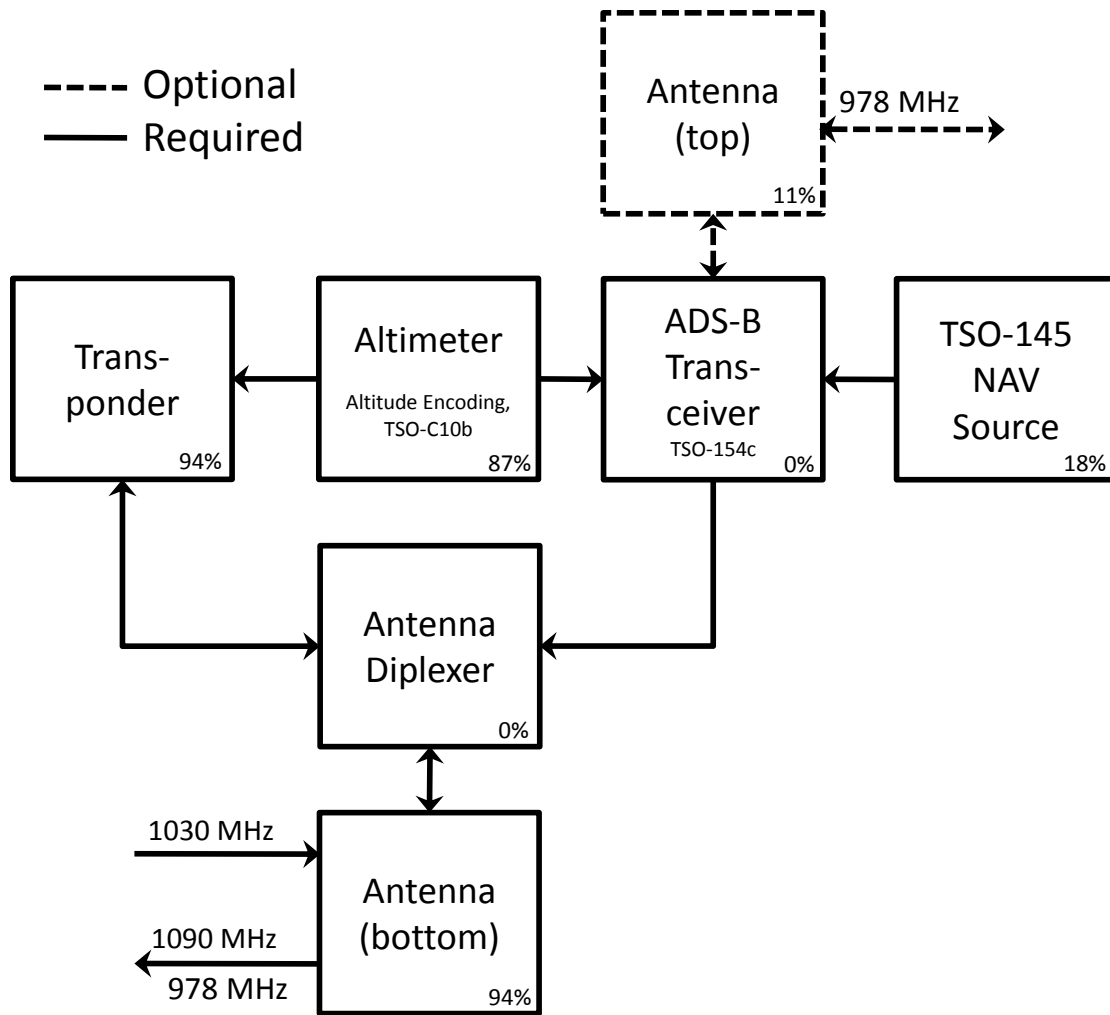

Figure 40: Detailed UAT ADS-B Avionics Architecture



## **Appendix C**

### **Survey of Potential ADS-B Benefits to the Soaring Community**

In light of recent mid-air collisions that included sailplanes, a survey specific to the soaring community was conducted (Kunzi and Hansman 2011). Currently, the FAA does not require sailplanes to carry transponders; it is expected that they will also be exempt from the requirement to equip with ADS-B. As such, the soaring community offers a unique opportunity to evaluate where ADS-B delivers benefit to General Aviation (GA) while equipage cost can be kept low<sup>4</sup>.

A survey was created to collect input from the soaring community. The objective of the survey was to evaluate which ADS-B applications are most beneficial to the soaring community and how willing the community is to adopt this new technology. The survey consisted of three sections. The first section contained an introduction to ADS-B to ensure that all participants were basing their answers on the same knowledge. Second, participants were asked to rank 13 ADS-B applications. The applications were a mix between ADS-B Out and ADS-B In applications. Applications that were specific to powered flight were omitted.

In giving their rankings, participants were asked to consider safety, efficiency, financial, and other operational benefits to themselves or the sailplane community as a whole. The ranking scale was a five point scale where 1 was low benefit, 3 was medium benefit and 5 was high benefit. 2 and 4 were for “low to medium” or “medium to high”, resp. Participants were also asked how much they would be willing to pay for this equipment and were given a field where they could suggest other potential ADS-B applications. In the third section, the participants were asked to anonymously provide information about their background and flying activity as well as any other comments they might have. Figure 41 shows a screenshot of the application ranking section.

---

<sup>4</sup> The avionics that are required to comply with the ADS-B rule have to be certified to FAA standards. Since the soaring community is not required to equip, the avionics can be certified to lower standards (such as lower transmission power), therefore reducing cost.

## 1. Traffic Information Service Broadcast (TIS-B)

### Description:

Using ADS-B In, traffic information is linked directly to the cockpit from the ground. This traffic information is in addition to the ADS-B messages received directly from other ADS-B aircraft -- it contains traffic targets that were determined using ground radar. This traffic information can then be displayed on the traffic display (see Figure 1).

- 1 - Low Benefit
- 2
- 3 - Medium Benefit
- 4
- 5 - High Benefit

Figure 1: ADS-B Traffic Display



Figure 41: Screenshot of Application Ranking Section in Survey

The link to the survey was published via the Soaring Society of America's (SSA) online newsletter on March 15th. It was also advertised at the beginning of April 2010 in the monthly magazine of the SSA. A later invitation was sent out to the national headquarters of the Civil Air Patrol where it was forwarded to its glider wing.

Over a period of three months (March 15th until June 15th, 2010), 266 valid responses were collected. As was the case with the Lester survey, some of the names of some of the applications used in the survey are not the same (Figure 42).

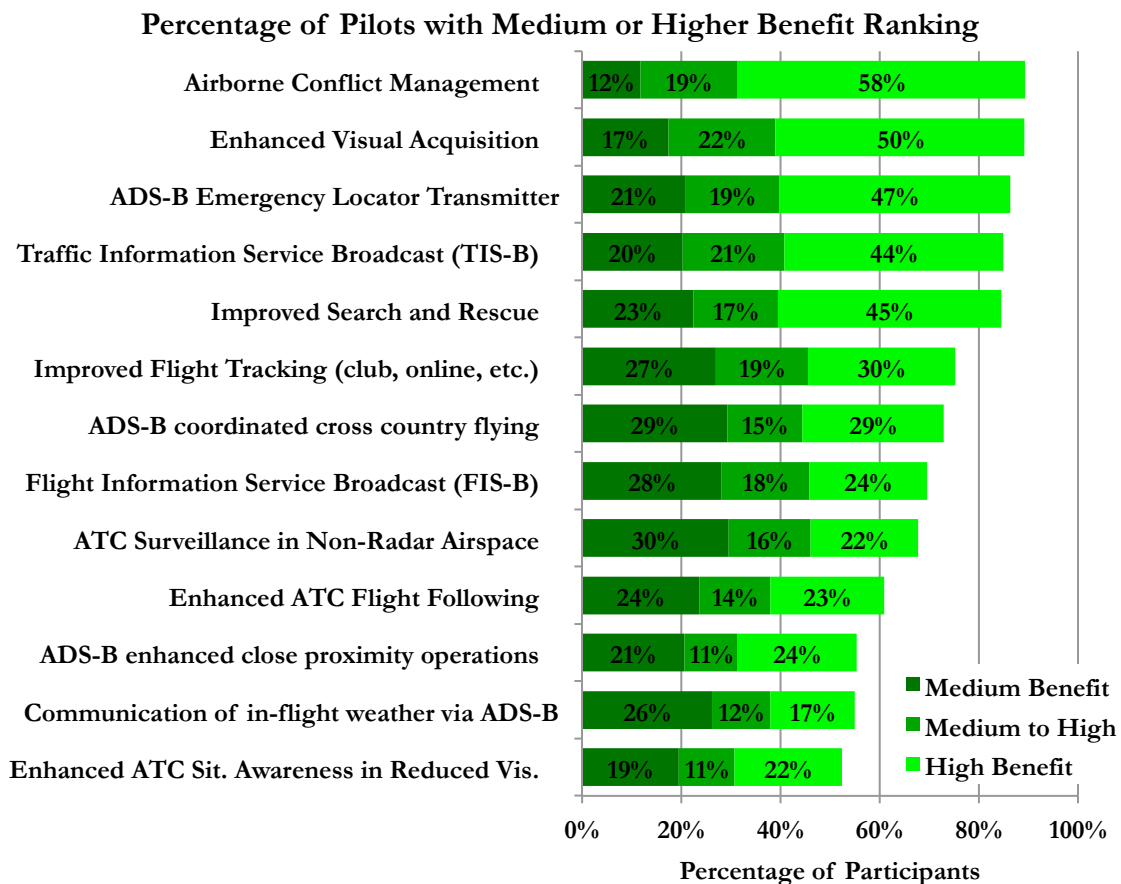

**Figure 42: Percentage of Participants That Ranked the Respective Application at Medium Benefit or Higher**

Figure 42 shows the percentage of participants that gave an application a rank of medium benefit or higher. The numbers in the bars represent the percentage a given ranking was chosen by the participants. For example, for the Airborne Conflict Management Application, 19% selected medium to high benefit. It can be seen that for every application, at least half of the participants perceived it to deliver at least medium benefit.

The applications that had more than 80% of participants rank them as medium benefit or higher were again mapped to the main user benefits that they enable. Just as before, an improvement in situation awareness was considered an intermediate step to the delivery of other user benefits. As can be seen in Table 19, the five applications ranked the highest all improve safety.

**Table 19: ADS-B In and Out High User Benefit Applications to the Soaring community**

<b>Benefit Category</b>	<b>High Benefit ADS-B Out Applications</b>	<b>High Benefit ADS-B In Applications</b>
Improved Safety	Improved Search and Rescue	TSA – Basic
	ADS-B Emergency Locator Transmitter	TSA with Alerts
		Traffic Information Service Broadcast (TIS-B)

# Appendix D

## Detailed Search and Rescue Process

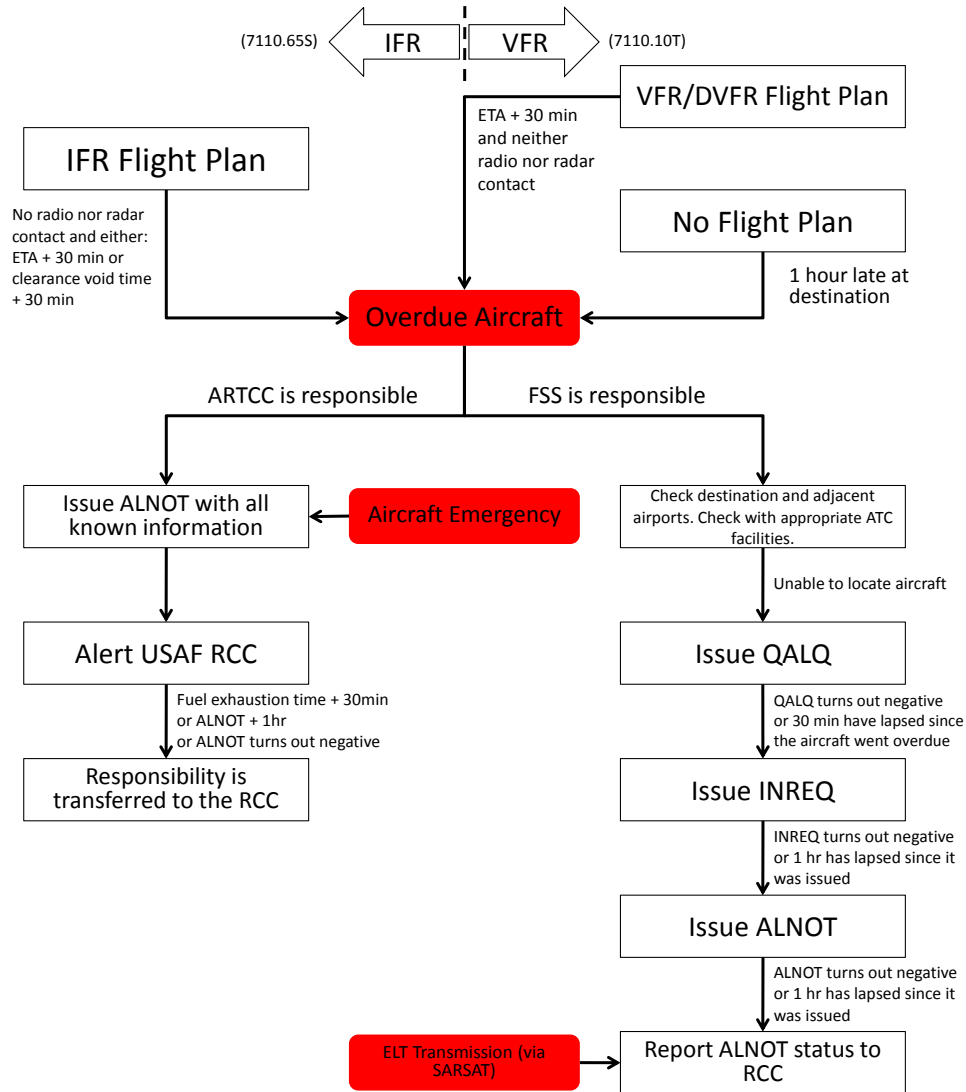

**QALQ:**  
A request for information (Flight Plan, etc) to the departure FSS station and where the FP is on file.

**INREQ:**  
Information Request (Flight Plan, etc), next level QALQ, transmitted to departure airport, flight watch stations along the route as well as other airports that could accommodate the aircraft. Parties have to check all records and have to respond within 1 hour.

**ALNOT:**  
Alert Notice, same as INREQ but includes all relevant parties within 50 miles on either side of filed route, also at regional level. The RCC cannot initiate a search without an ALNOT



**Appendix E**  
**List of Non-Towered Airports With More Than 10,000**  
**Yearly Operations and a RADAR Floor In Excess of**  
**1,500ft.**

<b>Airport ID</b>	<b>Operations</b>	<b>Lowest ETMS Track</b>	<b>Airport ID</b>	<b>Operations</b>	<b>Lowest ETMS Track</b>
01M	14250	2422	HLC	14600	3762
03S	11500	1696	HLX	16691	2607
08C	10000	1797	HMZ	14700	2738
0B7	18500	3730	HRU	11600	1958
0C0	20000	1987	HRX	13435	1915
0E0	29565	2901	HSB	12000	2602
0J8	30000	1915	HTH	12700	9860
0M4	10832	2532	I17	10200	1606
0Q5	15200	11781	I19	38900	1951
0R0	15000	2335	I40	19550	2021
0S7	18500	9236	I54	15350	3042
10D	13545	1970	I62	29359	1663
11N	11010	1825	I73	87263	2280
12K	12500	3709	I74	23480	1557
12N	24826	2317	ICR	21310	2967
13C	17200	3031	IDL	21500	1674
13N	11395	1688	IER	15715	4079
14S	11400	4186	IGM	51172	1751
15M	17625	3370	IYK	40595	14993
17J	10000	1552	JER	25510	3847
1A6	16025	2446	JMR	15000	1688
1C3	20000	1795	K23	11470	2903
1F0	12000	2156	K50	10200	1655
1F5	11600	4267	K61	20000	5584
1G4	131024	3650	K68	11060	2011
1H2	25000	1513	K71	14300	4588
1L8	21010	6053	K78	35800	2073
1M2	13000	3890	KLS	40860	2480
1N7	19790	1703	L00	15000	2485

<b>Airport ID</b>	<b>Operations</b>	<b>Lowest ETMS Track</b>	<b>Airport ID</b>	<b>Operations</b>	<b>Lowest ETMS Track</b>
102	76500	1621	L05	10500	9186
104	10000	2982	L06	10200	16485
1R1	15000	4088	L08	24500	3580
1R4	18000	3160	L22	14500	1676
1R7	13600	1711	L32	45000	2944
1S5	24000	1932	L33	10000	3926
1S9	11000	14916	L35	30000	1898
1V6	13778	1961	L66	12500	1597
22M	23100	1560	L71	37200	6246
24C	14028	1719	L94	50000	2680
2A6	32200	3087	LAR	10114	2316
2C6	10000	1639	LEM	19000	4429
2H0	15000	2882	LFK	18500	1704
2IS	11527	1980	LGD	16000	4283
2K3	23100	1901	LHV	30400	2044
2L0	25500	1638	LKP	20000	1753
201	12600	6385	LKU	20987	1807
203	12000	2152	LLJ	16350	8928
2V5	14600	2333	LLQ	13800	1730
32S	12500	3990	LND	11180	7027
36U	28302	4463	LNR	12000	2283
3FU	12500	2431	LQR	11900	2188
3I7	68000	1769	LUM	13550	1705
3M0	10700	3521	LWT	14620	3430
3M5	15784	2350	LXL	22450	2877
3N5	10695	1705	LXV	10000	3073
308	10000	4493	LYO	12000	1709
3S8	25000	3374	M11	13655	2157
3W7	13000	5850	M19	10000	1561
40I	16800	2095	M22	20125	1677
42J	32400	2104	M23	10070	2631
42U	11461	4743	M24	11600	1830
45K	11000	2055	M30	13000	2116
49B	23000	6757	M32	65000	3875
4F2	20000	1990	M34	11125	1564
4I9	19108	1815	M36	22100	2806



<b>Airport ID</b>	<b>Operations</b>	<b>Lowest ETMS Track</b>	<b>Airport ID</b>	<b>Operations</b>	<b>Lowest ETMS Track</b>
4M8	31500	3183	M37	10400	2763
4M9	33200	2707	M44	15200	2563
4S2	14210	4869	M53	10222	1529
4W8	12000	3465	M72	12300	2587
53U	10700	4115	M73	34200	1589
5A4	13200	1665	M78	12000	2462
5A6	14630	2636	M80	30000	2916
5G7	71980	2049	M89	31400	2218
5M1	51500	3610	MCX	14130	2324
61C	10850	2000	MEV	79800	2766
61S	16685	3347	MFI	26050	1723
63S	19200	17118	MKJ	10209	2330
65S	18900	14851	MLS	11200	4370
67L	15050	5285	MPV	32288	3535
6B0	16450	3010	MRH	43800	2789
6G1	11010	1550	MTJ	12379	2166
6G5	10150	1701	MVL	11976	3368
6M7	25050	1681	MVN	33000	2120
6S5	23600	7458	MWO	40050	1550
6Y8	23450	2336	MZZ	21404	1941
78A	10500	2128	N03	16989	2002
79N	18000	1685	N27	24020	1870
7M0	30080	3478	N53	18820	2320
7M1	25100	2859	N63	12150	1569
7M7	12016	2725	N68	13435	2116
7M8	13400	2619	N82	70000	1640
7T7	18600	1700	O02	16000	9400
8A7	30000	1582	O05	15700	5472
8B0	12700	4175	O16	16500	4954
8M1	11500	2929	O22	46020	1932
8M2	30130	2980	O42	12000	6575
8N2	10000	2259	O43	25900	4722
8N8	30000	1829	O46	16050	5362
8W2	15413	2525	O81	13100	5156
92A	10820	3530	O85	35000	1581
92C	14020	1715	OCH	22800	2045

<b>Airport ID</b>	<b>Operations</b>	<b>Lowest ETMS Track</b>	<b>Airport ID</b>	<b>Operations</b>	<b>Lowest ETMS Track</b>
9K7	20075	2585	OCQ	12370	1796
9S5	11530	6311	OGB	22420	1505
9V9	17900	2105	OKK	29391	2170
A09	16000	4415	OKZ	10150	1662
A20	14400	3363	OLS	35600	5120
A51	12500	5487	OMK	23750	5695
AAS	10200	2079	OVO	12403	1843
ACP	12500	3893	OVS	16400	2327
ACZ	15900	1736	P03	47050	17939
AFO	14820	4079	P20	10200	2048
AJG	11000	2871	P52	18720	5400
AJZ	12800	4207	PAN	41850	2043
ALS	30772	3461	PCZ	20160	2160
AOH	32500	1525	PEO	21200	1610
APV	37500	1638	PLR	34572	1653
AQO	11100	2898	PRZ	20000	4297
AQW	43780	2196	PSK	10308	2395
ARG	94000	1721	PSO	16850	4336
ARM	11800	2100	PVB	15550	1975
ASX	13025	2673	PWD	11360	4750
ATA	15600	2520	PYX	10000	3082
AUW	45000	2299	R47	13250	2099
AXV	29456	1662	RBG	31750	3471
B01	17000	4080	RCM	74325	3202
BAX	10000	2237	RCR	10097	1860
BBD	23523	2173	RHP	20500	2903
BCK	12320	1564	RIF	14219	8974
BDE	12825	1914	ROX	18300	1940
BDN	50100	3540	RPH	10500	2077
BHC	12400	2299	RRL	21810	2682
BIH	26000	2876	RSL	12010	2138
BML	12100	4339	RUT	27251	3613
BNG	10500	2781	RVL	19400	2081
BNL	23750	1654	RVN	12616	2920
BOK	22600	2966	RZN	14700	1711
BPK	49500	1972	RZZ	31500	2744

<b>Airport ID</b>	<b>Operations</b>	<b>Lowest ETMS Track</b>	<b>Airport ID</b>	<b>Operations</b>	<b>Lowest ETMS Track</b>
BTM	31678	4450	S03	26050	2815
BVX	35000	2635	S10	13000	5100
BWP	10860	3032	S18	13600	8551
BYG	12650	3295	S27	41400	1868
BYI	27750	4225	S33	10735	3563
C17	11372	1638	S39	10400	3550
C37	10000	1807	S70	30000	1861
CBE	14300	3025	S72	13100	6373
CCA	10400	2286	S78	12000	3250
CDN	36400	2511	S89	12750	4195
CKP	11200	2998	S94	13000	3519
CLS	47710	1924	S97	20000	7199
CNH	10500	2455	SBS	10698	2643
CNK	14550	2514	SBU	14000	2543
CQA	16212	2106	SEZ	50000	2170
CRX	21400	1675	SIY	13850	5052
CWC	22400	1897	SJN	14100	2663
CXP	83500	2003	SLB	19600	2512
CYW	24000	2792	SMN	24500	7957
D41	15100	11308	SMS	48300	2018
D74	14600	2734	SPF	27600	5319
D81	13500	2939	SPW	15090	2161
D86	12000	2625	SSQ	12550	2968
DEQ	11710	2645	SVE	12500	8851
DGL	11500	19015	SZP	97000	3757
DLS	16282	1553	SZT	30100	3269
DSV	48050	1538	T82	15675	1505
DUA	50030	2301	TCS	15700	3147
DUG	19650	3846	TDO	36363	3626
E45	33000	3133	TEX	23543	2022
E60	19800	3087	TGC	15240	1866
E68	20000	4227	TMK	25600	5327
E77	14000	5726	TNP	18000	6112
EAT	43805	1651	TSP	11000	2699
EED	10500	5017	U01	18025	1881
EFC	11750	4809	U03	15010	6228

<b>Airport ID</b>	<b>Operations</b>	<b>Lowest ETMS Track</b>	<b>Airport ID</b>	<b>Operations</b>	<b>Lowest ETMS Track</b>
EKS	11000	8777	U56	10800	1755
EKX	12400	1725	U76	22500	1596
ELN	60445	3536	U77	52700	3971
EOE	12100	1930	UBE	10900	1759
EYF	14500	1669	UNO	23860	1672
F24	14200	2247	UTS	12850	1837
F43	29000	2344	UWL	10896	1912
F62	12500	6679	VMR	16100	3454
F87	15500	1992	VYS	21000	1546
F88	24000	2644	W13	12383	2363
F89	20000	2662	W40	14550	2432
FDR	63700	2580	W45	11520	1598
FLP	16800	2181	W75	12476	1520
FOA	10000	2215	W99	16060	5037
FRR	12126	2091	WAY	13909	1531
GED	20700	1650	WMC	25575	5692
GGW	30010	4704	X04	21900	2757
GNG	26800	4993	X40	12000	2963
GUY	16075	1877	X61	20000	2322
GWS	15034	5184	Y91	10000	2753
GWW	16200	1566	YKN	20050	2194
GZH	134005	2216	ZEF	13350	2932
HEZ	17700	2728			

## **BIBLIOGRAPHY**

- Air Services Australia. *ADS-B Coverage*. 2011. [http://www.airservicesaustralia.com/projects/services/projects/adsb/docs/End\\_State\\_A100.pdf](http://www.airservicesaustralia.com/projects/services/projects/adsb/docs/End_State_A100.pdf) (accessed May 2011).
- FAA. "AC20-165, Airworthiness Approval of Automatic Dependent Surveillance - Broadcast (ADS-B) Out Systems." Advisory Circular, Washington, DC, 2010.
- FAA. "Air Traffic Control." FAA/DOT Order, Washington, DC, 2008.
- FAA. "Application Integrated Working Plan v2." Washington, DC, 2010.
- FAA. "Approval for ADS-B Out Systems." Washington, DC, DC, 2010.
- FAA. "Automatic Dependent Surveillance - Broadcast (ADS-B) Out Performance Requirements To Support Air Traffic Control (ATC) Service; Final Rule." Washington, DC, 2010.
- FAA. "Notice of Proposed Rulemaking (NPRM): ADS-B Out." Washington, DC, 2007.
- FAA. "TSO-154c, Universal Access Transceiver (UAT) Automatic Dependent Surveillance-Broadcast (ADS-B) Equipment Operating on Frequency of 978 MHz." Technical Standard Order, Washington, DC, 2009.
- FAA. "TSO-166b, Extended Squitter Automatic Dependent Surveillance - Broadcast (ADS-B) and Traffic Information Service - Broadcast (TIS-B) Equipment Operating on the Radio Frequency of 1090 Megahertz (MHz)." Technical Standard Order, Washington, DC, 2009.
- FAA. "TSO-C112, Air Traffic Control RADAR Beacon System/Mode Select (ATCRBS/Mode S) Airborne Equipment." Technical Standard Order, Washington, DC, 2008.
- FAA. "TSO-C129, TSO-C129a, Airborne Supplemental Navigation Equipment Using The Global Positioning System (GPS)." Technical Standard Order, Washington, DC, 1996.
- FAA. "TSO-C146c, Stand-Alone Airborne Navigation Equipment Using The Global Positioning System Augmented By The Satellite Based Augmentation System." Technical Standard Order, Washington, DC, 2008.
- FreeFlight Systems. *ADS-B Reg Status*. 2009. [http://freeflightsystems.com/prod\\_adsb\\_status.htm](http://freeflightsystems.com/prod_adsb_status.htm) (accessed May 2011).

- Hu, Xiaojie. *Technology Transition in the National Air Transportation System: Market Failure and Game Theoretic Analysis with Application to ADS-B*. PhD Thesis, Cambridge: MIT, 2008.
- ITT. "Surveillance Broadcast Services Air Interface Control Document V0.8." Wahshington, DC, 2010.
- Jenkins, Marisa. *A Systems Approach to Identifying Aircraft Equipage Requirements, Benefits, and Risks of ADS-B Applications*. Masters Thesis, Cambridge: MIT, 2009.
- Kunzi, Fabrice, and John Hansman. "Survey of Potential ADS-B Benefits for the Soaring Community." *ATIO*. Washington, DC: AIAA, 2011.
- Lester, Edward Ted. *Benefits and Incentives for ADS-B Equipage in the National Airspace System*. Masters Thesis, Cambridge: MIT, 2007.
- Marais, Karen, and Annalisa Weigel. "Encouraging and Ensuring Successful Technology Transition in Civil Aviation." Cambridge, MA: IEEE, 2007.
- Mozdzanowska, Aleksandra, Roland Weibel, Edward Lester, and John Hansman. "The Dynamics of Air Transportation System Transition." *Air Transportation Managment R&D Seminar*. Barcelona, 2007.
- NASDAC. *NASDAC Review of NTSB Weather-Related Accidents*. 2004. [http://www.asias.faa.gov/aviation\\_studies/weather\\_study/studyindex.html](http://www.asias.faa.gov/aviation_studies/weather_study/studyindex.html) (accessed 5 16, 2011).
- Parry, Matthew. *ADS-B Ground Station: Simple, Reliable, Maintainable and Affordable*. October 2005.
- RTCA. "DO-229D, Minimum Operational Performace Standard for Global Positioning System/ Wide Area Augmentation System Airborne Equipment." Technical Standard, Washington, DC, 2006.
- RTCA. "DO-260B, Minimum Operational Performance Standards for 1090 MHz Extended Squitter Automatic Dependent Surveillance – Broadcast (ADS-B) and Traffic Information Services – Broadcast (TIS-B)." Technical Standard, Washington, DC, 2009.

RTCA. "DO-282, Minimum Operational Performance Standards for Universal Access Transceiver (UAT) Automatic Dependent Surveillance - Broadcast (ADS-B)." Technical Standard, Washington, DC, 2009.

RTCA. "DO-282B, Minimum Operational Performance Standards for Universal Access Transceiver (UAT) Automatic Dependent Surveillance - Broadcast (ADS-B)." Technical Standard, Washington, DC, 2009.

Surveillance and Broadcast Services Program. "Traffic Information Service - Broadcast (TIS-B)/Flight Information Service - Broadcast (FIS-B) Essential Services Specification." Washington, DC, 2010.

Warwick, Graham. "Going Live." Aviation Week & Space Technology, March 2010. 46-47.