

**Modeling and Design of Material Separation  
Systems with Applications to Recycling**

by

Malima Isabelle Wolf

S.B., Massachusetts Institute of Technology (2003)

S.B., Massachusetts Institute of Technology (2004)

S.M., Massachusetts Institute of Technology (2006)

Submitted to the Department of Mechanical Engineering  
in partial fulfillment of the requirements for the degree of

Doctor of Philosophy in Mechanical Engineering

at the

MASSACHUSETTS INSTITUTE OF TECHNOLOGY

June 2011

© Massachusetts Institute of Technology 2011. All rights reserved.

Author .....  
Department of Mechanical Engineering  
May 26, 2011

Certified by.....  
Timothy G. Gutowski  
Professor of Mechanical Engineering  
Thesis Supervisor

Accepted by.....  
David E. Hardt  
Chairman, Department Committee on Graduate Students



# Modeling and Design of Material Separation Systems with Applications to Recycling

by

Malima Isabelle Wolf

Submitted to the Department of Mechanical Engineering  
on May 26, 2011, in partial fulfillment of the  
requirements for the degree of  
Doctor of Philosophy in Mechanical Engineering

## Abstract

Material separation technology is critical to the success of the material recycling industry. End-of-life products, post-consumer waste, industrial excess, or otherwise collected materials for reuse are typically mixed with other incompatible materials. These materials must be segregated using material separation processes. This thesis investigates the performance and design of material separation systems for recycling through modeling material flows within these systems.

The material separation system models developed here are suited to material recycling because they encompass all types of separation process and any configuration of those processes as well as treat binary and multi-material streams. These models capture the material behavior of separation systems through mass flow balance equations constructed using system configuration and process performance data. The Bayesian material separation model is used to capture the performance of separation stages processing a binary material mixture, while the material separation matrix model, developed here, captures the performance of stages processing multi-material mixtures. A network routing model is used to describe the links between processes within a separation system. The governing mass flow balance equations constructed from the process performance and routing data form systems of linear equations. These equations can be generated and solved programatically.

Separation performance can be captured through experimental methods or through physical modeling, but an investigation with either suggests that performance can vary under differing material input conditions and operational settings. Techniques for coping with these effects and potentially using them to tailor system behavior are discussed in a case study on the magnetic roller separation of beverage container shreds.

Two case studies use tailored economic metrics to evaluate decisions in the design of separation systems. The effects of operating decisions on an existing plastic container separating line are quantified by evaluating the additional profit from plastics-capture decisions. The second case study investigates the economics of installing a plastics separating line at an energy from waste facility. Modeling suggests several

possible configurations for a plastics separating line that outperform configurations suggested by industry experts, showing that the material separation system models developed in this work can provide design guidance in the recycling industry.

Thesis Supervisor: Timothy G. Gutowski  
Title: Professor of Mechanical Engineering

## Acknowledgments

Many people have contributed to the completion of my thesis, both in the professional and personal sense.

Professor Timothy Gutowski has been my advisor for the past four years. I've been lucky to have the opportunity to benefit from his advising and from teaching with him. His ability to ask the big questions is something I will always admire.

My committee members have also provided me with a lot of guidance. Dr. Stan Gershwin has been a strong supporter of my work as well as one of my most constructive critics. Professor Stephen Graves has provided a great systems perspective to our discussions as well as adding a sense of calm.

I would also like to thank Dr. Marcello Colledani of Politecnico di Milano for being a fun research partner. Our collaboration was exciting and productive. And I must give him great thanks for arranging and hosting my talk at Polimi.

I've also received a lot of support from our colleagues in industry. Dr. Roger Morton and his colleagues at Axion Consulting have provided valuable industry insight and feedback on our ideas. Eriez has provided great technical support, hosting us at their facilities and shedding some light into process performance. Mike Mankosa was kind enough to extend that invitation, and Joe Werham was generous with his time and expertise at their testing facilities. Bill Huling and his colleagues at Schnitzer gave us a fabulous tour, as did James Nathan and his colleagues at SIMS Metal Management Aerospace.

I also have to thank all my officemates in the Environmentally Benign Manufacturing Lab: Matthew, Gregoire, Amedeo, Davide, Marc, Nils, Kotaro, Thilo, Arnaud, Ante, Esther, Pamela, Phil. Now that I look at that list, I am pretty surprised by how long it is! I'm lucky to have had a great working environment with engaged and supportive colleagues. I've had great support from my advisor's administrative assistant, Karuna, and our lab administrator, David Rodriguera, too. Three of my colleagues have really been there for me over the last few years. I will always appreciate the kindness and sincerity of Avid, my desk double. Sahil has always provided me

with a objective opinion on my work and some sparkling repartee. And I can't give too many thanks *a mi amiga Natalia*, who laughed, swam, and worked long hours with me, showed me her adopted hometown, and will always be a friend.

I am lucky to have many other friends here at MIT, and in the Boston area, too many to thank, but I have to extend my thanks to Geoff, who has given me a lot of support and understanding, and to Rydia, who has reminded me to enjoy the good things in life.

My family have always been my best supporters. My parents, Margo and Stephen, have always been proud of me and understood that academia is a strange enterprise. I have to thank them for being a stable base in my life and loving me and being excited for me no matter what. I'm lucky to be a part of both the Wolf and the McGrath clans. We've welcomed a lot of great new people into our family lately, so there are too many to thank individually, but I can't not give my love to both of my awesome grandmothers, Jean and Beryl.

The Wendell family is my East Coast family. I want to thank them for letting me join in on everything, from Christmas parties to mountain hikes, and making me feel like a part of the family. Thanks to Mark and Mary, Dawn, and all.

There are two people who have provided the most support during my tenure as a PhD candidate; my sister, Violetta, and my fiancé, Ross. They've kept my spirits up when I've been working through tough times, and laughed with me in good times. I must give great thanks to both of them for seeing me through this PhD.

# Contents

<b>1</b>	<b>Introduction</b>	<b>17</b>
1.1	Motivation: Why Recycling? . . . . .	17
1.1.1	Energy Use in Primary and Secondary Materials Production . . . . .	18
1.1.2	Potential Energy Savings from Recycling . . . . .	20
1.1.3	Opportunities for Improvement in Material Recycling . . . . .	21
1.2	Problem Statement: Realistic Modeling of Separation Systems for Material Recycling . . . . .	24
1.2.1	Current State of Recycling System Modeling . . . . .	24
1.2.2	Improving the Modeling of Recycling Systems . . . . .	25
1.3	Overview . . . . .	28
<b>2</b>	<b>Review of Bayesian Material Separation Model</b>	<b>31</b>
2.1	Mathematical Basis . . . . .	32
2.2	Applying Bayesian Separation to Real Processes . . . . .	34
2.2.1	Separation Parameter Values from Literature and Experimentation . . . . .	35
2.2.2	Limitations in Applying Bayesian Separation . . . . .	35
<b>3</b>	<b>Modeling Binary Material Mixture Separation</b>	<b>41</b>
3.1	Binary Material Mixtures in Industry . . . . .	42
3.1.1	Current Industry Modeling Practices . . . . .	42
3.2	Modeling Components of Binary Separation Systems . . . . .	48

3.2.1	Individual Process Performance: Bayesian Material Separation Model . . . . .	48
3.2.2	Connecting Processes: Network Routing . . . . .	49
3.2.3	Describing Flows: Mass Balance Equations . . . . .	51
3.2.4	Solution Techniques for Binary Separation Systems . . . . .	53
3.3	Modeling and Optimizing Theoretical Systems . . . . .	54
3.3.1	Metrics for Binary Systems . . . . .	54
3.3.2	Optimal Systems of Two Identical Steps . . . . .	56
3.3.3	Optimal Systems of Three Identical Steps . . . . .	59
3.3.4	The Envelope of Optimal Systems . . . . .	59
3.3.5	Other Problem Types . . . . .	61
<b>4</b>	<b>Extending to Multi-Material Models</b>	<b>63</b>
4.1	Separation Performance Parameters for Multiple Materials: Extending the Bayesian Model . . . . .	65
4.1.1	Previous Multi-Material Models . . . . .	65
4.1.2	Material Separation Matrix Model . . . . .	66
4.2	Networks Processing Multiple Materials . . . . .	69
4.2.1	Routing Multiple Materials . . . . .	70
4.2.2	Multi-Material Mass Balance Equations . . . . .	71
4.2.3	Solution Techniques for Multi-Material Systems . . . . .	73
4.3	Modeling Theoretical Multi-Material Systems . . . . .	74
<b>5</b>	<b>Modeling Realistic Material Separation Systems</b>	<b>81</b>
5.1	Complexities of Real Systems . . . . .	82
5.1.1	Manufacturing System Features . . . . .	82
5.1.2	Process Categorization and Selection . . . . .	83
5.1.3	Variation in Processing Performance . . . . .	87
5.2	Metrics for Multi-Material Systems . . . . .	99
5.2.1	Material Performance Metrics . . . . .	99
5.2.2	Economic Metrics . . . . .	101



5.2.3	Energy and Environmental Performance . . . . .	105
<b>6</b>	<b>Case Studies</b>	<b>109</b>
6.1	Binary Separation of PET and Aluminum Flake . . . . .	110
6.1.1	System Profile . . . . .	110
6.1.2	Investigation of Configuration Options . . . . .	113
6.2	Site B: A Plastic Container Separation Facility . . . . .	116
6.2.1	Site B Facility Description . . . . .	116
6.2.2	Modeling Current Facility . . . . .	119
6.2.3	Investigation of Configuration Options . . . . .	127
6.3	Energy From Waste . . . . .	133
6.3.1	Facility Description . . . . .	133
6.3.2	Modeling Material Performance . . . . .	135
6.3.3	Evaluating Economic Performance Based on Material Performance . . . . .	137
6.3.4	Economic Metric: Payback Period . . . . .	142
6.3.5	Selecting Configurations with Plastics Recovery Economics . . . . .	142
6.3.6	Energy from Waste Summary . . . . .	151
6.4	Energy From Waste: Alternate Scenario . . . . .	153
6.4.1	Facility Description . . . . .	153
6.4.2	Modeling Material Performance . . . . .	154
6.4.3	Evaluating Economic Performance Based on Material Performance . . . . .	156
6.4.4	Economic Metric: Payback Period . . . . .	159
6.4.5	Selecting Configurations with Plastics Recovery Economics . . . . .	159
6.4.6	Energy from Waste Summary . . . . .	165
<b>7</b>	<b>Conclusions</b>	<b>167</b>
7.1	Model Performance . . . . .	167
7.2	Applicability to Real Systems . . . . .	168
7.2.1	Material Predictions . . . . .	168

7.2.2	Economics . . . . .	168
7.3	Contributions of this Work . . . . .	169
7.3.1	Flexible Modeling of Binary and Multi-Material Separation Systems . . . . .	169
7.3.2	Effects of Variation on Separation Process Performance . . . . .	170
7.4	Future Work . . . . .	171
7.4.1	Parameter Variability in Individual Processes . . . . .	171
7.4.2	Embedding Individual Process Models . . . . .	171
7.4.3	Incorporating Comminution . . . . .	172
<b>A Material Separation Matrices for Energy from Waste Processing</b>		<b>175</b>
<b>Bibliography</b>		<b>178</b>

# List of Figures

1-1	Energy savings based on end-of-life decision . . . . .	19
1-2	Emissions from materials production . . . . .	20
1-3	Material recycling rates for selected products . . . . .	23
2-1	Bayesian Material Separation model illustrating the effects of $r$ and $q$	33
2-2	$r$ and $q$ performance for multiple material separation processes . . . .	36
2-3	Simulated particle trajectories for mixed plastic and aluminum particles.	38
3-1	Relative efficiency of multi-stage separation systems using linear circuit analysis . . . . .	43
3-2	Diagram of separation system with internally recirculating loops ap- proaching infinity . . . . .	44
3-3	Recycling system with recirculating streams . . . . .	45
3-4	Flow sheet diagram of a metals separation plant . . . . .	47
3-5	A typical binary separation system with multiple separation stages . .	49
3-6	Single stage with all possible types of input connection . . . . .	52
3-7	Separation performance for the sixteen possible configurations of two identical separation steps . . . . .	58
3-8	Configurations of two identical steps with superior performance . . .	58
3-9	Separation performance for the 302 possible configurations of three identical separation steps . . . . .	60
3-10	Envelope of optimal system configurations . . . . .	61
4-1	Zero-Sort comingled curbside recycling facility diagram . . . . .	64

4-2	Flow sheet diagram of an end-of-life vehicle . . . . .	70
4-3	Single multi-material stage with all possible types of input connection	72
4-4	Separation performance for the 24 possible configurations of a 1-selecting process and a 2-selecting process . . . . .	77
4-5	Configurations of 1-selecting and 2-selecting processes with superior performance . . . . .	77
4-6	Separation performance for the 1872 possible configurations of a 1-selecting process, 2-selecting process, and 3-selecting process . . . . .	79
4-7	Configuration of 1-selecting, 2-selecting, and 3-selecting processes with superior performance . . . . .	79
5-1	Diagram of a magnetic drum separator . . . . .	85
5-2	Diagram of a sense-and-sort process employing both cameras and laser technology . . . . .	86
5-3	Deflection as a function of rotational speed for various materials . . . . .	87
5-4	Magnetic roller separator apparatus . . . . .	92
5-5	Eddy current separator in operation . . . . .	92
5-6	Drawing of a static magnetic separator . . . . .	92
5-7	Separation efficiencies for several processes under varying input material concentration . . . . .	93
5-8	Trajectories of aluminum and copper particles in an eddy-current separator . . . . .	94
5-9	A binary material mixture physically distributed by a separation process	95
5-10	Two overlapping normal distributions . . . . .	96
5-11	Separation efficiencies under varying separation efficiencies for three separation processes . . . . .	97
5-12	Normalized price purity curve for secondary materials production . . . . .	103
5-13	Energy intensity and mass flow rate for a variety of manufacturing and recycling processes . . . . .	106
6-1	Typical PET material as prepared for magnetic roller separation . . . . .	111

6-2	Separation efficiency of the rare-earth magnetic roller process . . . . .	112
6-3	Optimal selection of a two separation stage configuration and operating parameters for magnetic roller processing of PET and aluminum beverage container shreds . . . . .	114
6-4	Site B process flowsheet . . . . .	118
6-5	Typical DSD Fraction No. 320 plastics composition at Site B . . . . .	120
6-6	Site B plastics separation system configuration . . . . .	121
6-7	Site B production material fraction breakdown . . . . .	127
6-8	Alternative Site B plastics separation system configuration . . . . .	128
6-9	Two previously presented configurations for Site B . . . . .	130
6-10	Configurations of the energy from waste facility, with and without plastics separation . . . . .	134
6-11	Profitable single separation process configurations and their payback periods . . . . .	144
6-12	Configurations of two stages with shortest payback periods . . . . .	146
6-13	Configurations of three stages with shortest payback periods . . . . .	147
6-14	Configuration of four stages with shortest payback period . . . . .	148
6-15	A manually configured flowsheet focusing naturals . . . . .	150
6-16	Alternate scenario configurations of the energy from waste facility, with and without plastics separation . . . . .	154
6-17	Alternate scenario system of a single stage with the shortest payback period . . . . .	160
6-18	Alternate scenario system of two stages with the shortest payback period	161
6-19	Alternate scenario system of three stages with the shortest payback period . . . . .	161
6-20	Alternate scenario system of three stages with two mixed plastics stages	162
6-21	Alternate scenario user selected configuration sorting for all individual plastics . . . . .	164



# List of Tables

1.1	Embodied energy of production for a variety of materials . . . . .	20
1.2	Recycle fraction of different materials in current supply, potential energy savings of additional recycling . . . . .	21
4.1	Material separation matrix for a process processing three materials . . . . .	68
5.1	Potential cost sources of a separation system facility . . . . .	105
5.2	Typical energy intensities for some common material separation system processes . . . . .	108
6.1	Separation efficiency of the rare-earth magnetic roller process . . . . .	112
6.2	Aluminum contamination and PET recovery using a single magnetic roller stage . . . . .	113
6.3	Composition requirements for DSD Fraction No. 320 . . . . .	120
6.4	NIR process performance as given by Axion . . . . .	122
6.5	NIR process multi-material separation efficiencies . . . . .	123
6.6	Site B output fractions from Axion trials . . . . .	124
6.7	Site B performance trial product purities and yields . . . . .	124
6.8	Site B performance trial product purities and yields . . . . .	125
6.9	Input material concentration, as assumed by plant operators and as estimated from measured performance . . . . .	126
6.10	Site B performance trial product purities and yields modeled with new input composition . . . . .	126
6.11	Clear PET-targeting NIR machine 7 material separation matrix . . . . .	129

6.12 EfW material stream composition . . . . . 136

6.13 Peak sale values for pure, recycled plastics . . . . . 139

6.14 Energy content for EfW materials . . . . . 140

6.15 EfW material stream composition for alternate scenario . . . . . 156

A.1 NIR process multi-material separation efficiencies . . . . . 175



# Chapter 1

## Introduction

Material separation systems are used for a large variety of applications in many industries. Separation systems are used in chemical processing, mining, and food technology. One area where separation technology is critical to the success of the industry is material recycling. End-of-life products, post-consumer waste, industrial excess, or otherwise collected materials for reuse are typically mixed with other incompatible materials. These materials must be segregated using material separation processes. This thesis investigates the performance and design of separation systems through modeling material flows within these systems.

### 1.1 Motivation: Why Recycling?

In many industrialized nations, material consumption takes place at an unsustainable rate. Material flows can be significantly affected by end-of-life treatment. In particular, recycling can redirect and alter material flows by displacing materials used in manufacturing systems that would have otherwise been supplied from primary production. Increasing interest in material recycling is being driven by many factors, including material price fluctuations [112], laws and directives from high consumption countries intended to improve material recycling rates, such as Directive 2002/96/EC on waste electrical and electronic equipment (WEEE) [49] from the European Union and California's Electronic Waste Recycling Act (SB 20, 2003, Sher, and SB 50, 2004,

Sher) [18], and environmental concerns over material production and disposal.

This last point, that material recycling can mitigate the effects of material production and disposal, bears further investigation. The U.S. is a leading consumer of materials. While the U.S. represents 5% of the world's population, about a third of the world's non-energy material use is attributed to the U.S. [56]. This increased material consumption outpaces other nations with similar GDP per capita. A study of the material flows in several developed nations found that the per capita Domestic Processed Output (DPO), the total mass of materials which have been used in the national economy, before flowing into the environment, for the U.S. was 2.5 times greater than the average DPO of Japan, Germany, Austria, and the Netherlands [103]. While U.S. material consumption outpaces other developed countries, U.S. recycling rates are relatively poor. A recent study has shown that material recycling rates in the U.S. are well below the average of other developed OECD countries, and roughly half the rate of leaders in recycling [67].

This poor performance in material recycling represents an opportunity for improvement in many areas. The benefits of material recycling include reductions in mining and primary production, an end-of-life solution that captures waste that would otherwise be injected into the environment, economic opportunities, and energy savings. Many studies that have focused on this last benefit, from the point of view of life cycle assessment of end-of-life options [30] and extended life options [120], and life cycle energy and exergy studies [22, 39], have generally acknowledged the benefits of recycling from an energy perspective.

### **1.1.1 Energy Use in Primary and Secondary Materials Production**

Different end-of-life strategies offer different potential energy savings, as shown broadly in Figure 1-1. Material recycling offers the opportunity to short-circuit the energy use of material flows by cutting out the energy associated with initial material production and end-of-life disposal. The savings reaped from different material products

varies based on the material itself, the end-of-life source of the material, and the exact processes used to extract and re-work the material. For example, the energy savings is a large fraction of the original material energy cost for aluminum because of the high energy intensity of the extraction process from bauxite [119], while for paper products, the energy savings is reduced because the pulping and papermaking process used to make paper from used fiber sources is similar to that for making paper from trees [29].

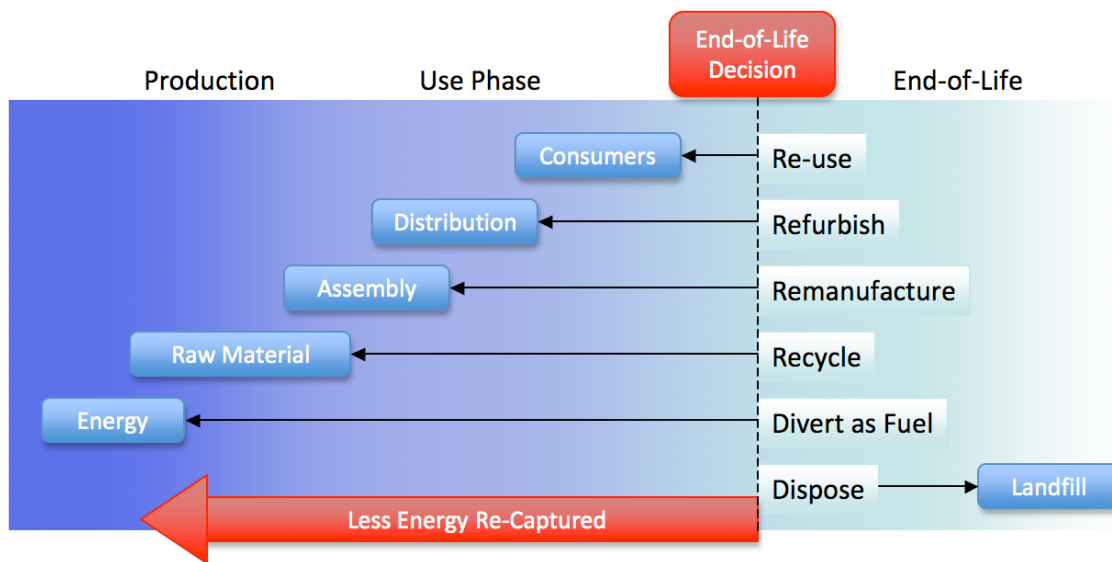

Figure 1-1: Energy savings based on end-of-life decision.

The energy use in secondary material production is compared to that of primary material production in Table 1.1. Metals in particular have a dramatic reduction of embodied energy from primary to secondary production. This reflects the usually high energy intensity of reducing metal ores, as in the case of reducing aluminum from bauxite. Other materials, including glass and the aforementioned paper, have proportionally less of an energy advantage from secondary recycling, typically because the material extraction process is less energy intensive than end purification processes or forming. Material recycling is the process by which these energy savings can be realized.

Table 1.1: Embodied energy of production for a variety of materials [5].

Material	Primary Production Energy (MJ/kg)	Secondary Production Energy (MJ/kg)
Steel	35	9.5
Plastic	100	45
Paper	25	19
Aluminum	220	20
Copper	70	18
Lead	55	9
Zinc	73	13
Glass	15	7

### 1.1.2 Potential Energy Savings from Recycling

The energy savings from transitioning from primary to secondary production materials presented in the preceding section on a per kilogram basis is impressive on its own, but also represents a significant opportunity for global energy and emissions savings. Roughly one third of global energy consumption and emissions are associated with industrial production, and more than half of that industrial energy consumption and emissions is driven by material production. Figure 1-2 shows the industrial and materials breakdown for emissions.

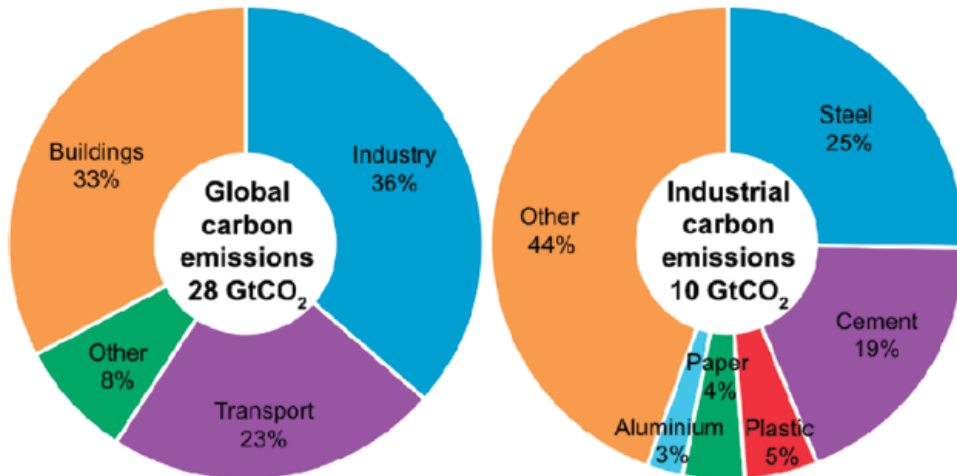

Figure 1-2: Emissions from materials production (from Allwood [2]).

With roughly 20% of world energy use attributable to materials production, en-

ergy reduction in materials production clearly has the potential for broader impact. Estimating the total potential impact requires understanding the current state of material recycling. Table 1.2 shows the current recycling fraction in a selection of material streams, including those materials from Figure 1-2. Assuming that those materials, steel, plastic, paper, and aluminum, can be captured at higher rates, the conversion to secondary material production can represent a sizable energy savings. The potential reduction in yearly energy use for each material is calculated using the difference in energy use in primary and secondary production as shown in Table 1.1, along with the potential improvement to the current recycle fraction. The potential energy savings for each material is also shown in Table 1.2.

Table 1.2: Recycle fraction of different materials in current supply, along with potential energy savings of additional recycling [5].

Material	Current Recycle Fraction	Potential Yearly Reduction in Energy
Steel	65%	35%
Plastic	5%	48%
Paper	43%	13%
Aluminum	39%	72%
Copper	5%	47%
Zinc	23%	23%
Glass	24%	40%

Increasing the recycled fraction for these materials could reduce world-wide energy consumption by as much as 5%. There are some limits to the potential of recycling. Some materials do not appear on this list, most notably cement. Because cement undergoes a chemical transition during setting, reuse of the material at end-of-life has limited applications.

### 1.1.3 Opportunities for Improvement in Material Recycling

The potential energy savings of material recycling presented in the preceding section are promising, but currently recycling rates necessary to reap these benefits are not achieved for a variety of reasons. The complex interplay of the social, economic, and

environmental costs and benefits of material recycling may create situations where recycling isn't the most favorable choice for the decision-maker [115]. For example, product manufacturers may have little interest in the recyclability of their products when they leave their hands. Producer takeback programs not only increase the rate of recycling for those products included in the takeback, but also improve the economic and environmental benefit received from each product [153]. Takeback laws are in effect in some parts of the United States, the European Union, and Japan [122, 110]. The creation of these takeback regulations is an example of how recycling rates can be improved.

These takeback laws are just one potential way to improve recycling rates. As mentioned previously, more general directives, such as those on electronic waste [49, 18] or end of life vehicles [48], can increase recycling rates through increased regulation, incentive programs, and other government encouragement. Other possibilities for improvement focus on organizational and technological improvements that expand recycling by making it economical and environmentally efficient to capture more material for reuse. Comingled curbside recycling is an example of a logistical choice that makes choosing to recycle simpler for consumers and municipal recycling providers. However, the extraction of useful materials from single stream recycling captures material at a lower rate and lower quality than traditional segregated recycling[105].

The comingled curbside recycling dilemma is just one example of how increasing end-of-life stream complexity will require greater performance from material separation systems to capture materials for reuse. Increasing product complexity can also lead to additional challenges in recycling [34, 32]. As shown in Figure 1-3, for products with a high total embodied material value, product recycling rates are affected by the level of mixing within the product. Increasing product complexity pushes products to be less recyclable. Increasing complexity must be offset by increases in recycling system performance.

Improving the performance of recycling systems can improve recycling rates by countering increased end-of-life material stream complexity, by improving the potential revenues from products that are already recycled through improved material

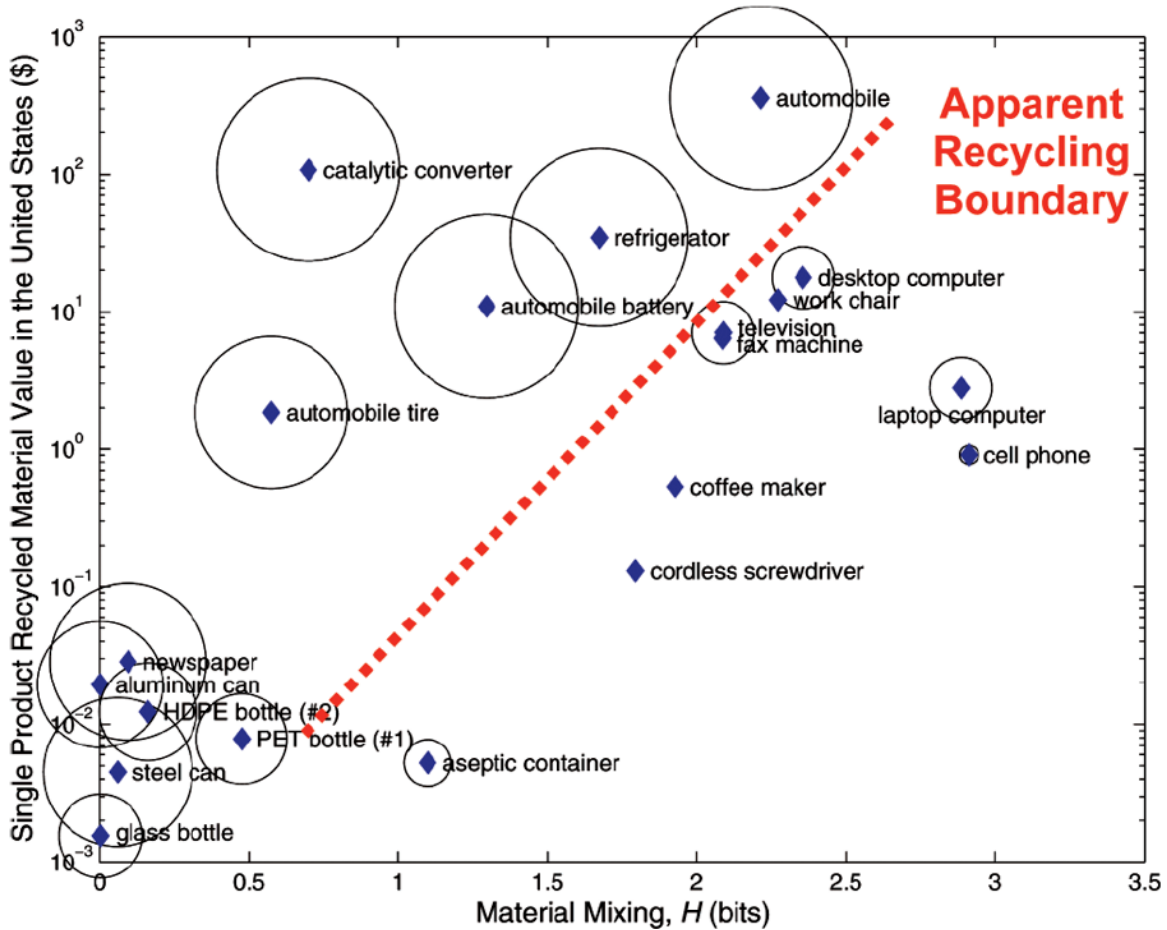

Figure 1-3: Material recycling rates for selected products with respect to total embodied material value and product mixing (from Dahmus [32]).

performance, and by increasing the demand for recycled materials in areas where recycled materials cannot currently replace primary materials due to their lower purity. Improving material separation system performance can be achieved through the introduction of new technologies, selecting the most effective processes and configurations of processes, and optimizing the operation of these systems. Selecting effective separation processes and systems requires modeling techniques that can capture the performance of these systems.

## **1.2 Problem Statement: Realistic Modeling of Separation Systems for Material Recycling**

Separation systems perform a core function in material recycling. Understanding the performance of these systems and their components is required to build and operate effective material separation systems. Current separation system modeling practices in industry and in academia are not adequate for describing the complex material separation systems used in many industries, in particular material recycling. These disadvantages of these techniques are described here, and the advantages of the new direction for material separation system modeling described in this work are presented.

### **1.2.1 Current State of Recycling System Modeling**

Material separation system modeling exists in both industry and academia. However, these models have limited utility when applied to recycling systems, calling for new efforts in the area of separation system modeling.

#### **Industry Practices**

In practice, separation system modeling is limited to descriptive models that incorporate measured material flow rates into system flow sheets. Separation systems are designed by trial and error based on past system performance and then tuned after installation. Separation systems that don't live up to expectations are modified by the addition of new components or technologies. Input material stream composition is not assessed frequently, under the assumption that it is constant or close enough to constant based on waste hauling standards, or that the separation systems are not flexible enough to adjust even if different materials are presented. The details of these methods will be discussed with more depth in Chapters 3 and 4.



## **Current Separation System Modeling**

Separation systems have been the subject of study in many disciplines, including mineral processing, chemical industries, food processing, and material recycling. As will be discussed in greater depth, Chapters 2, 3, and 4, models for individual process performance are frequently created for specific processes in a given field. In some cases, these systems are linked together into flowsheets. In mineral processing in particular, models that explore variable configurations are explored using optimization software.

## **Limitations to Current Modeling Efforts**

Material separation system modeling up to this point has typically focused on describing the performance of existing systems using specific processes and in specific configurations. Detailed physical models apply only to that specific process and typically require detailed information about the process operational settings and input materials. Mathematical models for material separation systems, such as linear circuit analysis [96] and models for systems with re-entrant flows [1], often apply only to certain types of configuration and require that separation stages all have the same type of performance. Computational models found in mineral processing, while flexible, also require that stages be of the same type of process. Typically, analytical models and the computational models of mineral processing are both designed to treat binary material mixtures, when many recycling systems process mixtures of multiple valuable materials. More complicated flowsheet models that incorporate a variety of processes, such as those presented by Van Schaik [162], are limited to evaluating a static configuration. The details of these models and more will be discussed in greater depth in Chapters 2, 3, and 4.

### **1.2.2 Improving the Modeling of Recycling Systems**

As suggested, current separation system modeling are not well equipped to address material separation systems for recycling, which require the incorporation of a variety

of types of process. Material recycling systems are part of a rapidly developing industry where the best forms for these separation systems may not be patterned directly on their predecessors. In particular, the addition of newly developed processes may disrupt the established design paradigms. Separation system modeling for material recycling systems should be able to incorporate any separation process and address any possible configuration. Additionally, many existing process and system models treat binary material mixtures. Input material streams in recycling separation systems may have many components that are desirable to capture, while disposing of unsorted materials from that system may be costly. Thus, many recycling separation systems are designed to separate multiple materials. Separation system modeling for recycling should incorporate process and system models that are capable of capturing the separation efficiencies of multiple materials.

### **Incorporation of Existing Models**

Existing models can provide guidance of the development of new modeling techniques. In particular, existing models provide valuable insight into the performance of individual processes. In this work, process performance is viewed at a high level, where the output distribution of material is more important than the mechanics of the process. The data on material performance provided by existing process models can be simplified into separation efficiencies that capture the essential material behavior of the process.

The models presented here for capturing separation process behavior are based on previous models for separation behavior, in particular the Bayesian separation model, which is presented in Chapter 2, along with developments in its use. Other models are also considered when creating multi-material separation models, in particular the transformation matrix model as described by Van Schaik [162]. Existing models for networks of separation processes also provide guidance. Mineral processing models have considered several methods for optimizing separation system process configuration. Abstract mathematical models have also provided guidance in handling more difficult configurations, including those with re-entrant streams.

## Balancing Flexibility and Simplicity Modeling

While highly comprehensive modeling can provide detailed results, it can be difficult to gather the data necessary to formulate the model, the analysis can be computationally difficult, and the resulting systems can be impossible to realize. Most models of separation systems must compromise on their required input parameters, configuration options, and solution techniques. The simplifications used with a given model limit the applicability of the model. The modeling techniques presented in this thesis aim to create a model of material separation systems that is appropriate to systems incorporating multiple process types, in particular material recycling systems.

Mineral processing separation system models focus on a single process type, froth flotation. Typically, the network of flow between separation stages allows for remixed and partial flows. The options for configuration become infinite with the addition of these variable flows, and optimization algorithms are required to select a configuration with good performance. This approach is unsuitable for modeling material recycling systems in part because modeling output streams as dividable into multiple parts contributes greatly to the complexity of the model, but would be impractical to construct and control in a typical material recycling system. The use of a separation model for only one type of process, froth flotation, also is impractical because multiple process types are included in most material recycling systems. On the other hand, some of the modeling techniques already used for recycling systems are difficult to implement because the process models are too detailed. The transformation matrix model requires detailed data about the categories of particles in an input stream and their separation response to each process. The detailed data requires measuring the process performance in place to provide the detailed data, which limits its applicability in other configurations.

The modeling techniques developed in this thesis combines flexibility in configuration with straightforward but encompassing process models, which include process models that capture the separation behavior of a process treating multiple materials. Whole process outputs will be able to be linked to any other process or system

output, but divisible outputs, unrealistic in most material recycling systems, will not be included. Process models that can describe separation performance in terms of material type, rather than particle type, with a few parameters will be used.

## 1.3 Overview

This work describes the development of a new modeling technique that builds on previous models to create a simple, programmatically solvable model for evaluating the material performance of a system of separation stages. The advantages and the restrictions of the model are discussed, along with several theoretical examples and case studies that illustrate the utility of the model.

**Chapter 2** This chapter introduces the Bayesian material separation model, a descriptive model that captures the separation performance of a process treating a binary material mixture. The mathematical development of this model is discussed along with practical applications of the model. The model is compared to other strategies for modeling separation processes.

**Chapter 3** Separation system modeling is described for systems processing binary material mixtures. The use of binary material separation systems in industry and previous models used to capture the behavior of these systems are discussed. The Bayesian material separation model is combined with network flow models to create a set of linear mass balance equations. The construction and solution of these equations is discussed. Theoretical examples demonstrate the analysis of material performance using this model.

**Chapter 4** The models for material separation system performance presented in Chapter 3 are extended to describe systems processing multiple materials. The material separation matrix is defined to describe the separation performance of a stage processing multiple materials. Similar network flow routing and system equation generating techniques are used for separation systems processing multiple materials.

Theoretical examples demonstrate the analysis of material performance for systems processing multiple materials.

**Chapter 5** This chapter discusses challenging aspects of applying the previously described modeling techniques to real material separation systems, including the affects of operational variation on separation performance. Metrics for analyzing system performance are also discussed.

**Chapter 6** Three case studies analyzed using the methods described in previous chapters are presented. The first case study considers the best configurations and machine settings for purification of polyethylene terephthalate for reuse in beverage container manufacturing. The second suggests operational settings for an existing plastic container separating line. The third case study investigates the profitable configurations for installing a plastics line at a energy from waste facility.

**Chapter 7** This chapter summarizes the findings of the thesis.



## Chapter 2

# Review of Bayesian Material Separation Model

A quantitative description of the performance of a separation process is critical to analyzing the result of a separation. This description should be able to describe the performance of any kind of separation process, independent of its industry of use or physical characteristic of separation. In essence, given a process separating a known set of materials, the description should specify how the materials are distributed into the output streams.

Several strategies for describing the performance of a separation process have been proposed. While conventions for describing the performance of processes separating three or more materials haven't been established universally, a few models describing the separation of binary material mixtures have been accepted in prominent separation fields.

A process description commonly used to describe binary separation is the metrics of grade and recovery. These metrics are standard in the mineral processing industry, where separation processes were used to prepare mined material for eventual treatment to transform the ores into usable material. The focus of processing was to extract a valuable material from a relatively high volume of unusable material, and thus the metrics of grade and recovery focus on the desirable material and the material stream designed to capture that material. Recovery is the fraction of the de-

sirable material entering a process that is captured in the designated output stream, while grade is the concentration of that desirable material in that output stream.

In other fields of separation, such as material recycling, both materials in a binary material mixture might be desired materials. The Bayesian Separation model, as developed by Timothy Gutowski and Jeffrey Dahmus, describes the separation of a binary material mixture into two output streams in a way treats the two materials similarly [69]. The Bayesian Material Separation model describes the performance of both materials by their recovery into their designated output stream.

## 2.1 Mathematical Basis

Mathematically, the Bayesian Separation model as envisioned by Gutowski and Dahmus has its roots in Bayesian probability models [69, 68]. The model is structured such that the separation process can be considered as a test and the separation parameters are the probabilities of success for that test.

Consider a binary material mixture, of materials  $M1$  and  $M2$ . The separation process selects and diverts the material  $M1$  with test  $A$ , and the material  $M2$  with test  $A^c$ . Then define the following probabilities

$$\begin{aligned}
 p(A|M1) &= r \\
 p(A^c|M1) &= 1 - r \\
 p(A|M2) &= 1 - q \\
 p(A^c|M2) &= q
 \end{aligned}
 \tag{2.1}$$

Thus, material  $M1$  is identified correctly with probability of  $r$ , and the material  $M2$  is identified correctly with the probability of  $q$ . These two probabilities,  $r$  and  $q$ , can be considered as the separation parameters for the process, the ability of the process to correctly divert these two materials.

In a general binary material system, special terminology is used to designate the two materials and their designated output streams [71, 166, 27]. To distinguish be-



tween the two materials and their corresponding desired output streams, one material is designated as the target material,  $T$ , and the other is designated as the non-target material,  $N$ . The terms target and non-target are not necessarily meant to imply the relative desirability or value of the two materials. However, in the case that one material is more desirable than the other, it may be designated as the target material. For a binary separation process separating these materials into two output streams, each of these two output streams will be designated as the desired output stream for one of these two materials. In specific, the output stream designated as the desired output stream for the target material is called the primary output stream, while the the output stream designated as the desired output stream for the non-target material is called the secondary output stream. The separation parameter  $r$  is linked to the target material, and is used to denote its recovery into the primary output stream, while the separation parameter  $q$  denotes the recovery of the non-target material into the secondary output stream.

Using the conventions of target and non-target material and primary and secondary output stream, the separation parameters  $r$  and  $q$  can be used to track the diversion of the materials through the separation process. Given a mass of target material,  $m^T$ , and a mass of non-target material,  $m^N$ , the diagram in Figure 2-1 illustrates the distribution of the materials into the output streams. In mathematical

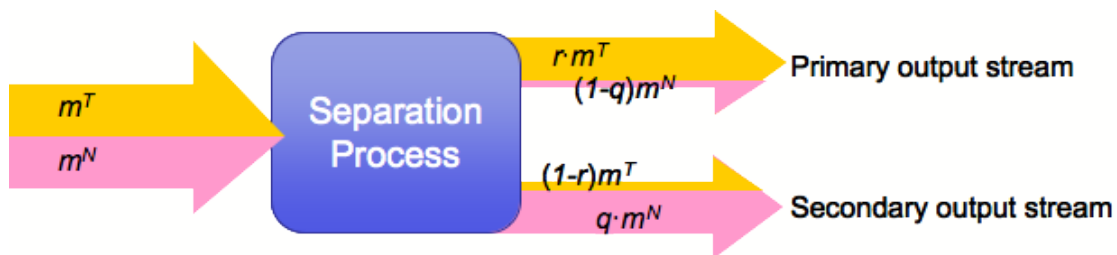

Figure 2-1: Bayesian Material Separation model illustrating the effects of  $r$  and  $q$ .

terms, where the designation  $p$  refers to the primary output stream and  $s$  refers to

the secondary output stream,

$$\begin{aligned}
 m_p^T &= rm^T \\
 m_s^T &= (1 - r)m^T \\
 m_p^N &= (1 - q)m^N \\
 m_s^N &= qm^N
 \end{aligned}
 \tag{2.2}$$

## 2.2 Applying Bayesian Separation to Real Processes

The Bayesian Material Separation model can be used to describe any binary separation process, from any industry with any physical separation mechanism. To qualify as a binary separation process, a material separation process must have exactly two outputs. While the material entering the process does not have to be two distinct homogenous materials, all the materials entering the process have to be assigned as either target or non-target material. Any process that meets these qualifications, of having two distinct output streams and processing a mixture of two defined materials, can be evaluated using the Bayesian Material Separation model.

Transforming the formulas found in Equations 2.2 creates expressions that can be used to calculate the separation parameters  $r$  and  $q$ , as shown below:

$$r = \frac{m_p^T}{m_{in}^T} \tag{2.3}$$

$$q = \frac{m_s^N}{m_{in}^N} \tag{2.4}$$

Material performance data, collected through experimental trials or through physical modeling, can be analyzed using these simple equations to determine separation performance. These separation parameter values are specific to the exact separation process and material mixture used in the experimental trial or simulation.

The values of  $r$  and  $q$  calculated can illuminate some properties of the separation. To be considered a successful separation,  $r + q > 1$ . A sum of  $r$  and  $q$  lower than 1 indicates a misidentified separation, where the designation of the primary and sec-

ondary output streams is incorrect. If the sum of  $r$  and  $q$  is exactly equal to 1, then the process is merely a stream splitting operation, not a separation. Generally speaking, separation processes with high values of  $r$  and  $q$  are considered more successful than those with lower values.

### **2.2.1 Separation Parameter Values from Literature and Experimentation**

Given Equations 2.3 and 2.4, we can investigate the performance of separation processes. Figure 2-2 [168, 163, 87, 172, 171, 154, 129, 75, 70] shows values of  $r$  and  $q$  for a wide variety of processes taken from literature and experimentation.

This figure represents separation processes from several industries, but product material recycling features most prominently. Most of these data-points are collected from literature, from studies of the performance of separation processes or separation process systems. Some of this data comes from our own experimentation with magnetic roller separation processes for aluminum in plastic mixtures with Eriez Magnetics, Inc. [75]. Some processes have several data points, reflecting separation performance under different operating parameters or with different materials.

These real separations generally follow the guideline that  $r + q > 1$ , and in many cases the sum of  $r$  and  $q$  approaches 2, the ideal maximum. Very few usable processes operate in the regime where both  $r$  and  $q$  are moderate (in the range of 0.5-0.7). In processes with multiple operational configurations, such as the magnetic roller process, the performance at these different settings often presents tradeoffs in terms of  $r$  and  $q$ .

### **2.2.2 Limitations in Applying Bayesian Separation**

The Bayesian Material Separation model can be applied in a variety of separations, but there are some limitations on its use. In general, the model can be used to describe the result of any binary separation, but its use as a predictive tool is dependent on the accuracy of the probabilistic description used in the model.

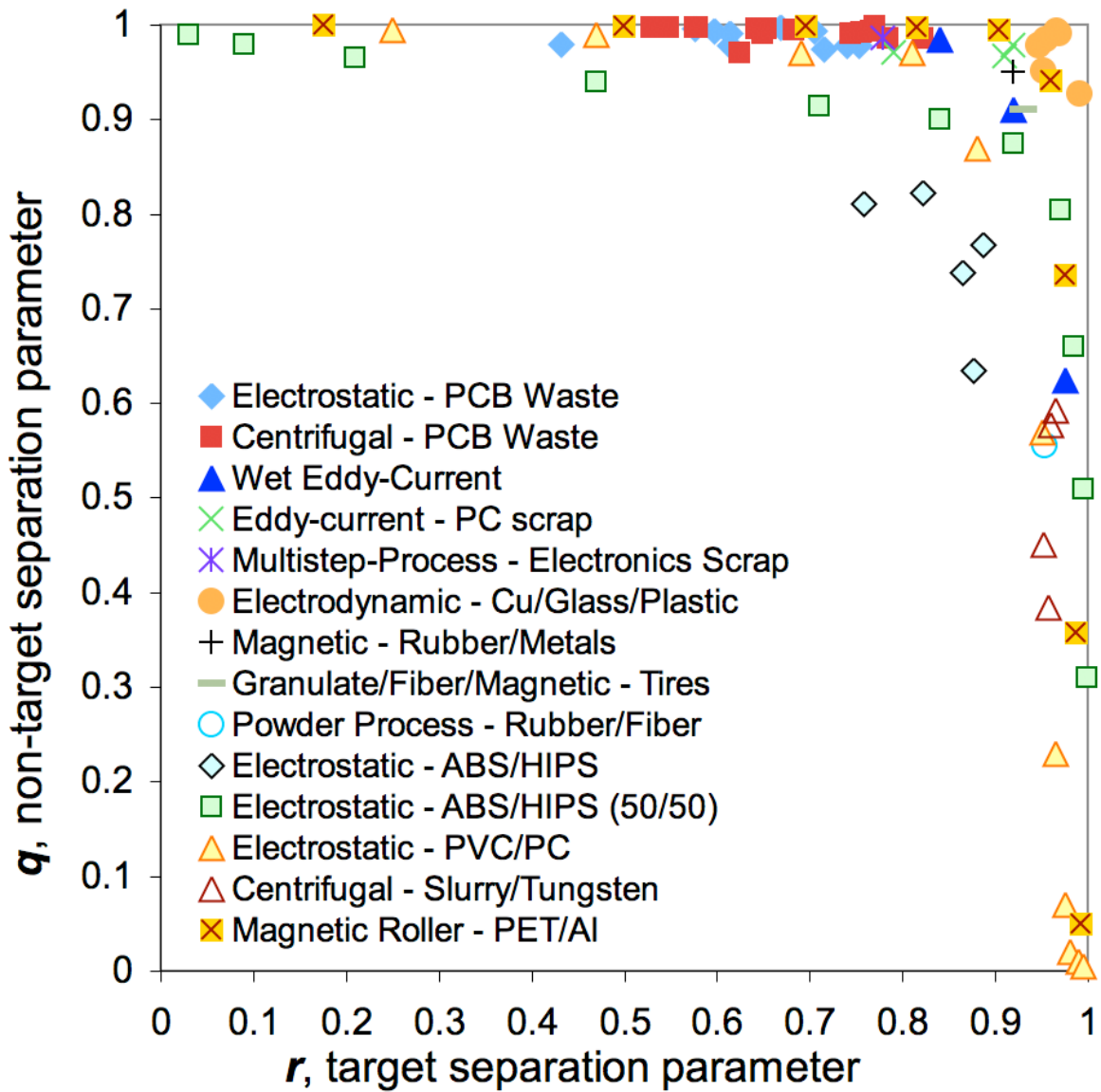

Figure 2-2:  $r$  and  $q$  performance for multiple material separation processes. [168, 163, 87, 172, 171, 154, 129, 75, 70]

The Bayesian model works best as a predictive model when each of the particles classified in each of the two material streams has the same probability of being captured correctly as each other particle in its material stream. That is, for a given process, the Bayesian model is most useful when the probability most individual particles of target material have an individual probability of being correctly captured of  $r$ , the overall material stream separation parameter. This is not always the case in separation systems and is not always the case in other models of binary separation.

### **Comparison to Physical Modeling**

Physical process modeling estimates the performance of a separation process through detailed modeling of the forces on each particle. Physical process models have been created for several separation processes, but one of the most studied in the field of recycling is eddy current separation. Detailed physical process models for eddy current separation include the calculation of Lorentz force based on particle properties and the separator's magnetic field, aerodynamic drag, gravity force, and in some cases particle to particle and belt interactions [117, 116, 173, 101, 62]. An example of simulated particle trajectories is shown in Figure 2-3. To simulate the separation efficiency of a process using these models, a comprehensive accounting of all the particles entering a process and a complete physical description of the process are required. In the case of the eddy current model, the physical description must include information about belt speed, belt thickness, magnet configuration on the magnetic drum and its rotational speed, splitter placement, and possibly more. Simulation of the response of each particle is necessary to estimate the overall material performance of the process. Bulk performance measurements from experimental results cannot be used to determine the details of the forces acting on particles in a process or their trajectories.

As shown in Figure 2-3, physical modeling can provide more-detailed analysis of particle trajectories, for all types of particles, including those of different shapes and material content. However, accurate separation estimates require detailed and accurate information about the input particles and the physical parameters of the separa-

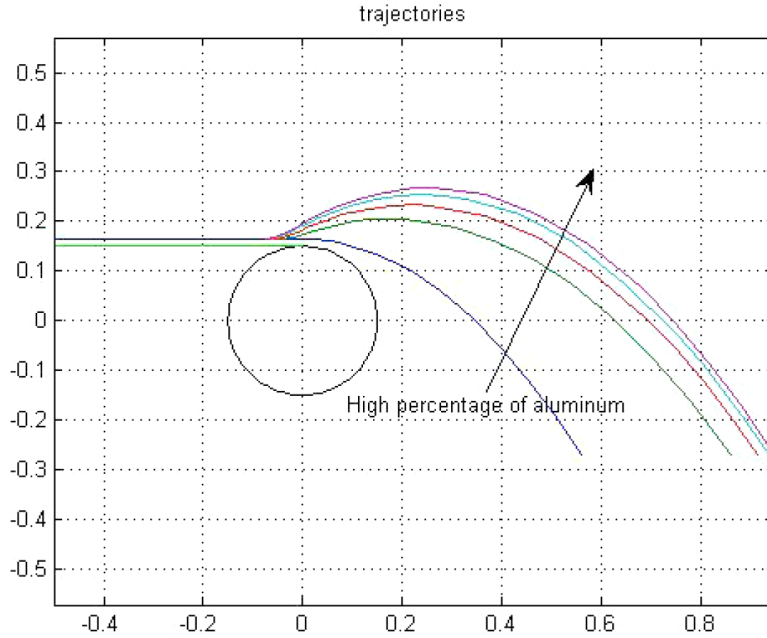

Figure 2-3: Simulated particle trajectories for mixed plastic and aluminum particles with varying aluminum content. From [62].

tion process. The depth of information required is a significant drawback for physical modeling, as opposed to measurement-based Bayesian Material Separation modeling. Another disadvantage to physical process modeling is its inability to account for variation in particle response. Any additional physical effects, such as particle orientation and particle collision in the case of eddy current processes, which may have significant impact on trajectories, must be modeled as well [101, 62]. Any simplification made to these models hides complications that create an unpredictability in the results. Undescribed or unknown effects manifest as randomness.

### Probabilistic Vs. Deterministic Modeling

An essential difference between the Bayesian Material Separation model and physical modeling is that the response of a particle to a separation process is probabilistic in the case of the Bayesian model and deterministic in the case of physical modeling. The Bayesian model predicts that the expected value of the response of any given particle is the same as that of the bulk material, while a physical model provides a precise, fixed trajectory, effectively assigning each particle a probability of correct

capture of 0 or 1.

The reality of separation lies in between these two options. The Bayesian model doesn't capture the variation in response based on variation in particles, while the physical models do not acknowledge variation in response for an individual particle. The most realistic model would take into account individual particle properties and the variation in response that these particles can have in a single process. A compromise between the two models might be a simple parameter model reflecting physical properties of the particles that calculates a probability of separation.





## Chapter 3

# Modeling Binary Material Mixture Separation

The separation of binary material mixtures is a problem that touches many industries, including the material recycling industry. Binary mixture separation is the division of a mixture of two materials into its two components, yielding at least one output material stream that is desirable at its new concentration. The simplest binary material mixture separation system is one consisting of a single separation stage. In some cases, an individual separation step cannot provide the desired recovery or purity for the output materials. In this case, processing these once-treated output streams again with the same or different processes can make it possible to attain material purity goals.

Analyzing the performance of systems processing binary material mixtures becomes more complex as the systems themselves become more complex. A binary material processing system consisting of one step can be analyzed using the Bayesian Material Separation model, physical process models, or other process models, as described in Chapter 2. Systems with multiple processing steps, however, require additional modeling. At the very least, they require modeling of the structure of processing steps, the diversion of output streams from each process into either system outputs for collection or into further processing.

Here I propose a modeling approach for material separation systems of more than

one step. The modeling approach proposed here combines the Bayesian Material Separation model with network flow models to produce a flexible model for multi-step binary material separation systems. As discussed later in this chapter, this model has an advantage over previous modeling efforts in that it is flexible, in the sense that it can handle any arrangement of binary separation steps, easily formulated and solved, and requires very basic knowledge of process performance compared to many models. This chapter introduces the model and its construction, and demonstrates its utility through theoretical and practical examples.

## **3.1 Binary Material Mixtures in Industry**

Many industries use separation systems that can be modeled as binary separation systems. Many material mixtures in the mineral processing industry can be treated as binary materials, where one valuable mineral or ore is separated from a bulk of non-desirable material. In recycling, many material separation systems can be represented as binary material systems. Examples of multi-step binary material separation in recycling include the purification of beverage container shred for processing into new PET bottles, or the capture of magnetic materials in scrap recycling. These multi-step binary separation systems play an important role in creating desirable materials in these industries. Given the multitude of industry roles for binary separation, models for multi-step binary separation systems are an important tool for separation industries.

### **3.1.1 Current Industry Modeling Practices**

Several models for binary separation systems have been developed for use in industry. Existing models cover a broad range of possible separation systems and solution techniques, and deliver their results in a variety of forms. Some models focus on delivering analytical solutions to theoretical problems, while some are technical models designed to analyze very specific types of system. Some numerical models can describe only limited configurations.

Analytical models of separation systems can be a helpful tool in understanding binary material separation systems. Some can generate symbolic solutions for performance, allowing for easy understanding of the effects of processes performance and configuration on separation. On the other hand, many analytical models have limitations in the process type and configurations that they can process.

Several analytical models have been proposed for analyzing systems of identical steps. Linear circuit analysis compares the performance of systems of multiple identical separation steps to a single step. This technique compares the derivative of concentrate-to-feed ratio,  $(C/F)$ , with respect to the separating property,  $X$ , to the derivative of partition probability for a single step,  $P$ , also with respect to  $X$ . Essentially, this is comparing how much more effective the system of separation processes is than a single step of that process. Here the measure of efficiency is the sharpness of separation, which is the ability of the system to distinguish between particles of different separation property values. Figure 3-1 gives some examples of relative efficiencies for basic systems with recirculating streams, as taken from Luttrell [96].

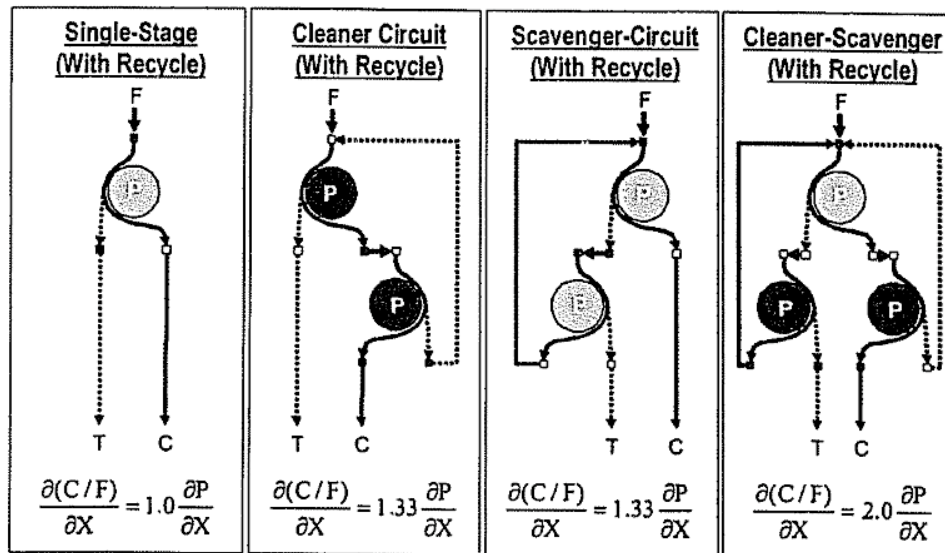

Figure 3-1: Relative efficiency of multi-stage separation systems as compared to a single separation step using linear circuit analysis. From Luttrell [96].

[164]

This analysis provides a different result than many analytical models. Rather than

giving an evaluation of the material outputs of a multi-stage separation system, this model yields a comparison between systems on sharpness of separation. While this gives an overview of the the performance of the system, additional analysis is required to evaluate material performance. Another limitation on linear circuit analysis is that system configurations are limited to linear circuits. Figure 3-2 shows an example of a linear circuit with internally recirculating loops, approaching infinity. Systems with additional interconnections can be created that cannot be evaluated using linear circuit analysis.

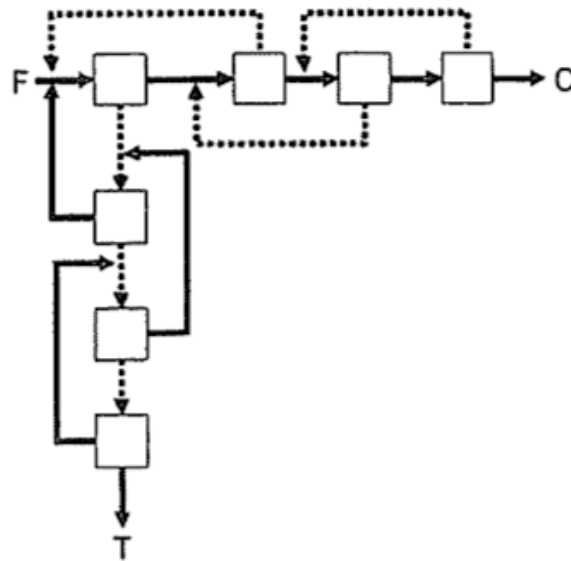

Figure 3-2: Diagram of separation system with internally recirculating loops approaching infinity. From Luttrell [96].

Other mathematical models have been proposed for analyzing separation systems with internally recirculating streams. One model proposed by Albino considers systems of the type shown in Figure 3-3 [1]. These systems have chains of recirculating streams, where the secondary outputs of these steps are recirculated into previous steps with the intent of scavenging target material from waste streams.

This model uses the Bayesian Material Separation model as described in Chapter 2 for the performance of individual separation steps. Here, the steps are assumed to all have identical performance in terms of  $r$  and  $q$ . The outputs of each step can be expressed algebraically as a function of the system input masses of the target and

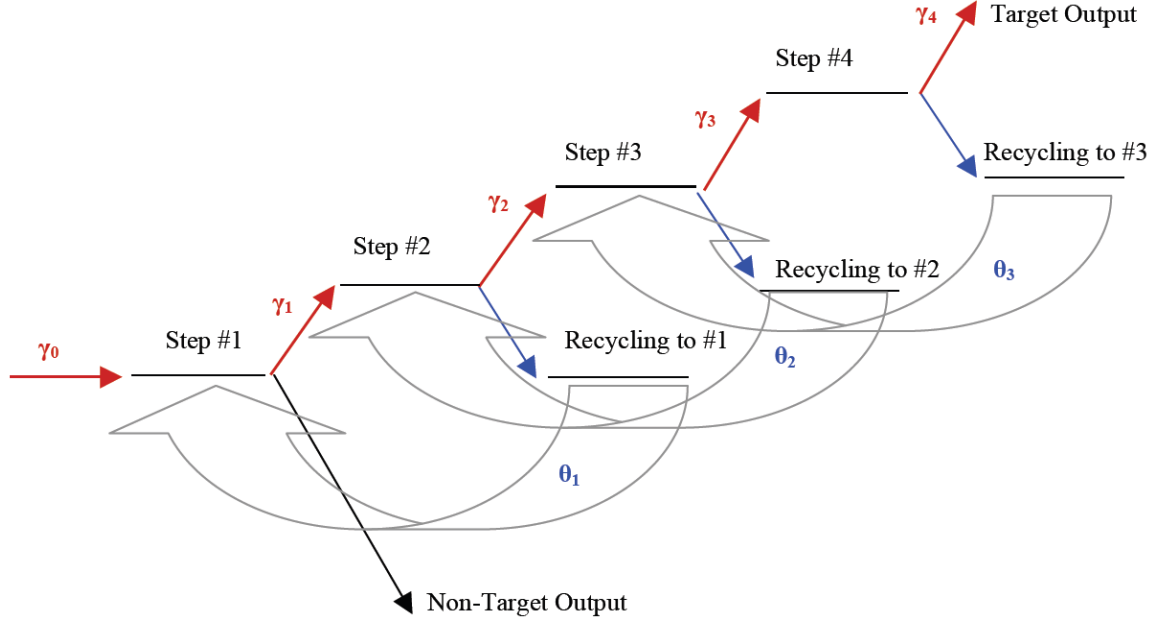

Figure 3-3: Recycling system with recirculating streams as proposed by Albino [1].

non-target materials. The symbolic expressions can be manipulated to understand the relationships between inputs, process performance, and outputs. For example, the target mass output of the last step in the system shown in Figure 3-3 is

$$\gamma_4 = \frac{r^4 \gamma_0}{1 - 3r + 4r^2 - 2r^3 + r^4} \quad (3.1)$$

where  $\gamma_0$  is the input mass of target material,  $\gamma_4$  is the output mass of target material from the primary output stream of the last separation stage, and  $r$  is the target separation efficiency of all the separation steps. Taking the derivative of Equation 3.1 with respect to  $r$  explores the relationship between changing  $r$  and changing target material output. The ability to explore these results symbolically is an advantage of this model, however, there are a limited set of systems that can be explored this way.

Analytical models for specific systems can present more configuration options than the general models presented by Luttrell and Albino. A large body of work exists that models froth flotation in mineral processing. Froth flotation separation systems typically consist of banks of cascading cells, the concentrates and tailings of which can be diverted to other cell banks or to system outputs at a variable fraction. The

basic structure of most froth flotation models includes a network model linking the inputs and outputs of the cell banks, and a model for individual cell performance, such as assumed residence time [104] or enhancement factor [82, 167]. Various network models can be used, including Markov chains [169], though like circuit analysis, Markov chains can only be simplified in some cases. Process models for the cells and banks of cells can be incorporated into these models, the most common being to model the flotation kinetics as a first-order rate process [131]. The overall system performance can be improved by identifying the ideal performance characteristics based on these flotation kinetics for the individual froth flotation cell banks [165]. Modeling the performance and configuration of stages within these banks, typically categorized as cleaner, rougher, and scavenger banks, is another important concern of froth flotation modeling [164]. These models can describe the performance of almost arbitrary configurations of flotation cells, including split stream diversion that would be difficult to realize in most other separation processes, including typical material and product recycling systems, but rely on froth flotation models for individual process performance, limiting their applicability to other types of separation processes and systems. One possible additional application is to plastics, as froth flotation for plastics is an emerging field of separation for recycling [3, 147]

Other analytical models focus on estimating the bulk of flow in recycling, in order to quantify the material output volume and also its value [151, 86, 95]. These models are intended to assist in planning of recycling systems. Typically, these models can investigate most types of separation processes for recycling, but the configurations they treat are limited to forward branching separation trees. The intent of these models is not to provide an accurate prediction of material performance, but a rough estimate of material volume distribution through the separation system and its outputs. Some recycling models attempt to take into account both planning aspects and the material recycling system [161]. Very detailed separation process and system modeling, that can include particle classifications such as size and liberation, is at the core of some of these models [162]. Others look at overall material system performance, from materials production to manufacturing and use to end-of-life, using very simplified

material performance models to estimate economic performance [89].

Although a wide variety of analytical models exist, the most common modeling tactic used in practice is numerical calculation through flow sheets. Flow sheets that follow the flow of materials through the separation processes of a system can describe the performance of a separation system, but not predict it. For example, Figure 3-4 shows a multi-metals separation system with the mass flows enumerated from measurements.

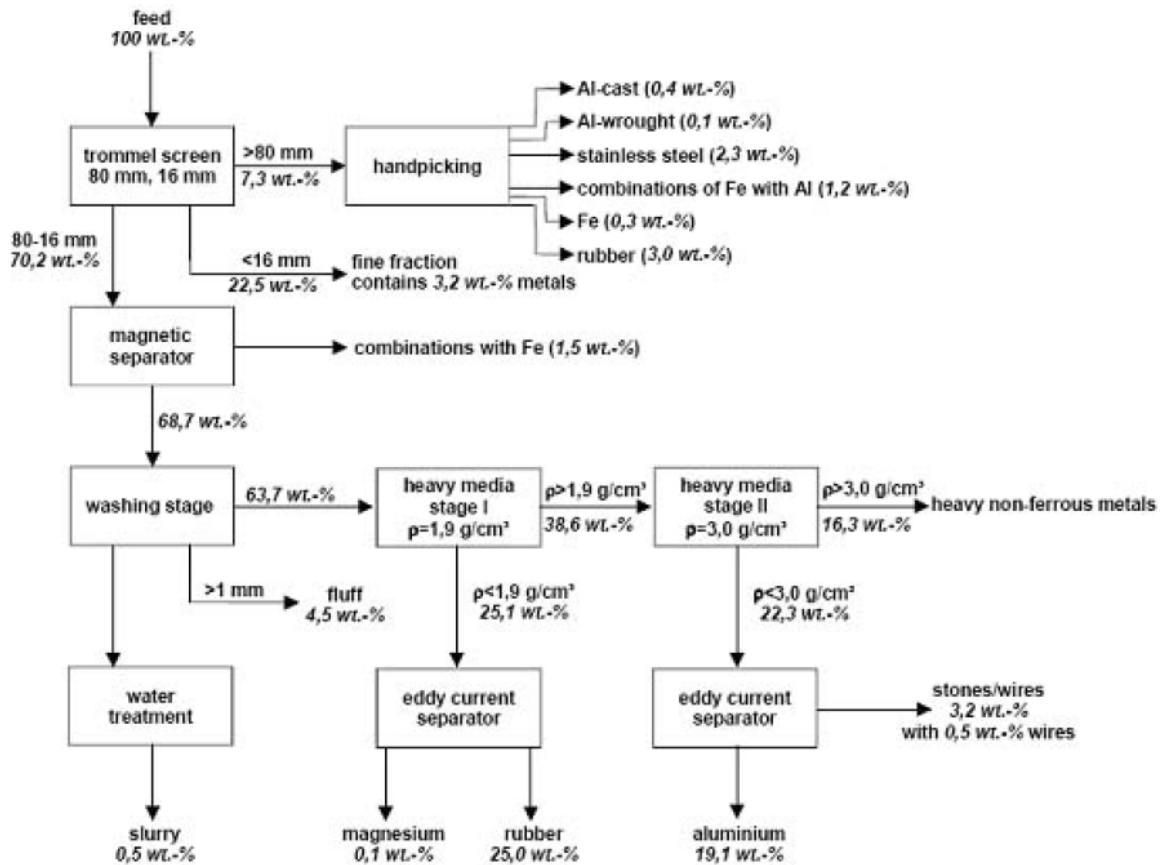

Figure 3-4: Flow sheet diagram of a metals separation plant with mass flow rate fractions [99].

Basic flow sheets can also be used for predictive modeling when process models are added. Flow sheets are limited to analyzing configurations without recirculating flows, as the output of each step must be calculated sequentially, from the system material inputs to the system material outputs.

## 3.2 Modeling Components of Binary Separation Systems

The advantage of the binary separation system model proposed here is that any configuration constructed from any mix of binary separation process can be modeled. This section describes the essential components for the model, and how they contribute to making this Binary Separation model widely applicable to separation systems for material recycling.

### 3.2.1 Individual Process Performance: Bayesian Material Separation Model

Chapter 2 introduced the Bayesian Material Separation model. This model for individual process performance is a flexible model that describes the separation of a binary material mixture by a process that divides it into two output streams, each intended to capture one of the two material components of the mixture. This model characterizes the performance of an individual process using two parameters,  $r$  and  $q$ , that describe the separation performance for each material in terms of its recovery into the designated output streams.

The Bayesian Material Separation model provides several advantages for the overall model. First, the Bayesian Material Separation model can be used to describe the performance of any binary separation process without detailed physical process models. An expectation for the Bayesian Material Separation model is that the separation parameter values given for a process will be specific to the material stream and the operating parameters used in the system, thus, no detailed models are necessary. The performance of each separation step in a system can be incorporated into the separation system easily.



### 3.2.2 Connecting Processes: Network Routing

Separation systems consist of several separation steps networked together to improve performance over that of a single process. The flow of materials into the system, the connections between processes in the system, and the collection of system outputs shape the overall performance of the system. Thus, a model of the network of separation steps is critical to analyzing the performance of a separation system.

The network routing model presented here and in Wolf et al. [166] is a method to model the connections within a binary separation system. An example binary separation system is shown below in Figure 3-5. Some assumptions about the nature of the connections are assumed. In the case of binary separation system, at least one input material stream is assumed. Each process, in accordance with the Bayesian Material Separation model, has two output streams, a primary and a secondary stream. These outputs are assumed to be diverted into their destination processes or outputs as undivided streams. The system is assumed to have at least two collection outputs, as a single output would simply be a rejoining of the materials flowing through the process.

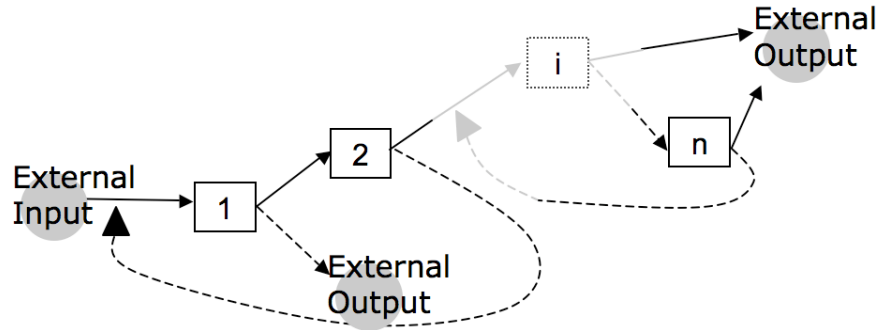

Figure 3-5: A typical binary separation system with multiple separation stages.

Based on the categories of flows described above, we can create a network of directional connections that describes a given system topology. The three types of stage that are included are system inputs, separation steps within the system, and system outputs. Here we define the sets representing each of these types of stage.  $I_{ext}$  is the set of all external inputs to the separation system. Each input is assumed

to have one entrance into the system, and at least one external input is assumed to exist for any given separation system.  $S$  is the set of  $n$  binary separation processes that are part of the separation system. At least one separation process is assumed to exist within the separation system. Each separation process is assumed to have two outputs, a  $O_{ext}$  is the set of external system outputs. At least two system outputs are assumed to exist, though there may be more. System outputs have no output streams themselves, as they are assumed to be end-points for the system.

The connections between each stage's output and the stage in the system it is directed toward are represented as a directed edge connecting the two. The connections have limitations placed on them based on initiating stage type. The output of each system input in  $I_{ext}$  is assumed to be directed to a separation process in the system. The set of directed connections from the external inputs is designated  $E_{ext}$ . Both the primary and secondary outputs of each separation step in  $S$  are assumed to be directed at other processes within the system or to system outputs. For organizational purposes, the connections from primary and secondary outputs are divided into separate categories,  $E_p$  and  $E_s$ . Restating mathematically,

$$E_{ext} = \{(l, i) \mid \forall l \in I_{ext} \text{ where } i \in S\} \quad (3.2)$$

$$E_p = \{(i, j) \mid \forall i \in S \text{ where } j \in S \cup O_{ext}\} \quad (3.3)$$

$$E_s = \{(i, k) \mid \forall i \in S \text{ where } k \in S \cup O_{ext}\} \quad (3.4)$$

The union of these three sets of connections,  $E = E_{ext} \cup E_p \cup E_s$ , describes a complete system topology, representing all the stages within the separation system and the connections between these steps.

The network description given here can be used to represent any material separation system of binary separation steps. There are several advantages to this network model. The network is simplified in several ways. Because the network considers only binary separation steps, only two categories of process output are created. In many realistic separation systems, the flows from external inputs and from process outputs are kept whole, or only split for capacity reasons where the streams are evenly split

and fed into identical processes. Eliminating the option to split streams by directing each output to a single stage creates a simpler model. This feature will have an impact on the later solutions discussed in Section 3.3.

### 3.2.3 Describing Flows: Mass Balance Equations

While assigning the connections within a system through a network model expresses the material flow pattern within the system, the exact quantities of the material flow within a system are determined by the separation performance of the individual steps and the amounts of the input flows. Combining these pieces of information with the network model can yield mass flow balance equations that describe the balance between the mass flow through a process and the streams directed into it through external inputs or system process outputs.

Several assumptions are used to simplify the process of creating and solving these equations. The system is assumed to be operating at steady state. The flows entering the system are assumed to be constant, and the separation processes are assumed to have no storage capacity. The processes are assumed to be operating under steady operating conditions, and thus the value of the separation parameters are assumed to be fixed.

Using these assumptions, a system of mass balance equations is created for each material, representing the mass flow through each stage for that material. The mass flow for each given material from the external inputs,  $I_{ext}$  is assumed to be known, and thus for each external input, we expect to have a mass flow rate statements of the form

$$m_l^T = t_l \tag{3.5}$$

$$m_l^N = n_l \tag{3.6}$$

where  $t_l$  is the mass flow rate of target material entering the separation system from external input  $l$  and  $n_l$  is the mass flow rate of non-target material entering the system from that input. For separation processes within the system, in  $S$ , or system outputs,

in  $O_{ext}$ , the flow of material through that stage must be balanced against the mass flow into the system from other sources, including external system inputs and other process outputs. Figure 3-6 shows a separation step with all types of possible inputs. While it is assumed that external outputs are fed as a whole into a process within the system, the material of a given type flowing from another separation stage is divided at its output into primary and secondary output streams. Here, the Bayesian Material Separation model is used to calculate the fraction of material of a given type flowing into each output. For the target material, the fraction of target material flowing through the upstream process that is directed to the following stage along a primary output connection is  $r$ , while the fraction flowing along a secondary output connection is  $(1 - r)$ , as shown.

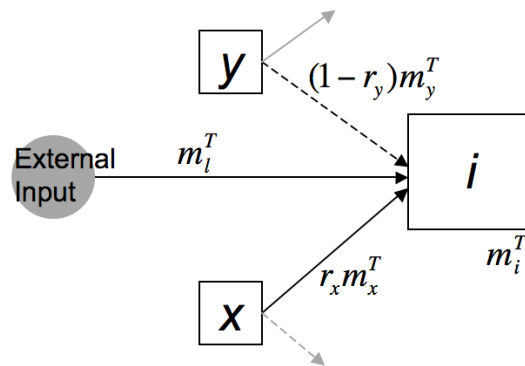

Figure 3-6: Single stage (separation process or system output) with all possible types of input connection for target material flow.

Individual mass flow balance equations are created for each separation stage or system output in the set  $S \cup O_{ext}$ . For each individual stage in that set, the mass flow of each type is balanced against the incoming flows from external inputs and primary and secondary outputs from separation stages directed at that stage. The balance for target material is shown in Equation 3.7, while the balance for non-target material is shown in Equation 3.8. For each stage, all external input connections to the stage in  $E_{ext}$ , all primary output connections to the stage in  $E_p$ , and all secondary output connections to the stage in  $E_s$  are included in the mass balance. As discussed previously, the mass of each material flowing from each separation stage connected

to the current stage through  $E_p$  or  $E_s$  is calculated using the upstream process's separation efficiency for that material.

$$m_i^T = \sum_{(l,i) \in E_{ext}} m_l^T + \sum_{(x,i) \in E_p} r_x m_x^T + \sum_{(y,i) \in E_s} (1 - r_y) m_y^T \quad (3.7)$$

$$m_i^N = \sum_{(l,i) \in E_{ext}} m_l^N + \sum_{(x,i) \in E_p} (1 - q_x) m_x^N + \sum_{(y,i) \in E_s} q_y m_y^N \quad (3.8)$$

These equations are generated from separation performance data and the network model. Combined with a complete set of external material input equations of the form shown in Equations 3.5 and 3.6, these equations form two systems of linear equations, one for the target material flow and one for the not target material flow. These equations create a complete description of material flow in the binary material separation system.

### 3.2.4 Solution Techniques for Binary Separation Systems

As discussed in Section 3.2.3, the equations developed for each material are linear systems of equations. As such any typical solution technique for linear equations can be applied to these systems, including direct manipulation of the equations or through matrix manipulation.

Certain conditions are required to create a system of equations that has a defined solution. Some of these conditions correspond with physical requirements for the system. First, a fully solvable system of equations requires that each separation process in the system must be on a directional path that starts at an external input and ends at a system output. Another requirement is that no separation process has a self-directed output, that is, neither of its outputs can loop back directly into its input. Rules including these match up physically realistic systems under our assumptions with mathematically solvable systems of equations.

## 3.3 Modeling and Optimizing Theoretical Systems

The ability to model the performance of a separation system provides the opportunity to understand the effectiveness of such a system without access to the real thing. As discussed in Section 3.1, there are a wide variety of industries that provide systems suitable for analysis with this model. This model may be used to predict a the performance of individual system configuration as given, but in many cases modeling efforts will be used to find an optimal system configuration among many options.

Previous separation system modeling efforts, discussed in Section 3.1.1, have frequently been applied to system optimization. In many cases, this optimization takes the basic form of comparing a few expertly selected options. More complex, automated optimization has been explored in several areas of separation. One type of separation that has been explored using advanced techniques is mineral froth flotation. The typical formulations of these froth flotation systems requires optimization of both routing parameters and individual process parameters, leading to more complex problems. In general, these problem have been simplified to linear programming problems [59, 170], or mixed-integer linear programming [24]. Most of these froth flotation models focus on optimizing material performance, but some focus on other aspects, such as optimizing cell capacity [77]. Generally, these optimization problems are solved by computer, in some cases through enumeration, but in other cases computer optimization search techniques are used, including advanced techniques such as genetic algorithms [65, 64]. These froth flotation modeling techniques have influenced recycling researchers to formulate and solve complex material recycling separation process optimization problems using non-linear optimization [162].

### 3.3.1 Metrics for Binary Systems

The goal of separation system modeling is evaluating the performance of that system. In the case of even a basic binary separation system, the resulting material diversion is described by several measurements. Rather than a direct comparison of the material flow at all points in a system, the most effective way to evaluate the performance of

a system and compare multiple systems is to develop measurement metrics. Because the system model presented here is mass flow-based, mass flow-based metrics are the most straightforward to construct, but other metrics for energy use or savings, economics, and thermodynamic effectiveness can be constructed. In general, material performance and economic metrics are commonly used for industry applications.

The most basic metrics in the case of our model are mass flow-based metrics. Output material quantities and qualities are important to the economics of a system, and are commonly measured in real systems to gauge performance. Thus, focusing on output material performance is an effective way to create a basic comparison of systems.

In the case of a binary material separation system, several assumptions have an effect on the construction of output metrics for the system. One assumption is that the system will have two output material streams, with the intent of separating the two materials into the two separate streams. It is also assumed that the system has one external material input. In some cases, rather than focus on both system outputs, focusing on one material output can provide structure. This is often the case in the mineral processing industry, where one material is the target of the separation system.

In this case, we can use separation system metrics based in mineral processing. The most common metrics are recovery and grade for the target material [109]. The recovery of the target material is defined as the fraction of target material that makes it to the intended system output stream. The grade is defined as the concentration of target material in that target output stream. Equations 3.9 and 3.10 describe these two metrics.

$$R^T = \frac{m_{T_{out}}^T}{m_{in}^T} \quad (3.9)$$

$$G^T = \frac{m_{T_{out}}^T}{m_{T_{out}}^T + m_{T_{out}}^N} \quad (3.10)$$

where  $R^T$  is the target material recovery,  $m_{T_{out}}^T$  is the mass flow rate of target material into the system target output, and  $m_{in}^T$  is the mass flow rate of target material into the system through the external input.  $G^T$  is the target material grade and  $m_{T_{out}}^N$  is

the mass flow rate of non-target material into the system target output.

The metrics of recovery and grade provide a way to compare material separation systems. These metrics focus on the target material, but also provide enough information to calculate the non-target material performance.

### 3.3.2 Optimal Systems of Two Identical Steps

Investigating simple systems is a good way to demonstrate the utility of the binary separation system model. Modeling the individual separation steps as abstract processes can simplify the analysis and take the emphasis off of the process performance to focus on network performance. As a separation system of a single step does not require a network model, the simplest system that requires a network analysis would include two separation steps.

Here we present simple examples of theoretical systems of two steps. We consider two identical steps and the options to arrange these two processes into a separation system. First, we specify the performance of the two separation steps and the input material mixture.

$$\begin{aligned}
 r_1 = r_2 = q_1 = q_2 &= 0.85 \\
 m_{in}^T = m_{in}^N &= 0.5m_{in}
 \end{aligned}
 \tag{3.11}$$

Using the binary separation system model, we can investigate the separation properties of the networks that can be created using these two steps. As the two steps are identical, the shape of the network, but not the placement of the two processes within that network do not have an effect. All possible configurations of the two separation stages with one external system input and two external system outputs are considered by iterating through all possible sets of connections between processes, as described by Equations 3.2, 3.3, and 3.4. Configurations that do not comply with the guidelines described in Section 3.2.4 are discarded. Those conditions are restated here: Either output of a given process cannot be directed to its own input. Each processes must



be connected in a directional path between at least one external system output and at least one external system output. The separation processes, external inputs, and external outputs must form one connected network. Finally, no separation process can have both its primary and secondary output directed to the same stage.

Using these restrictions and also eliminating any repeated configurations due to the indistinguishable performance of the two separation processes, there are sixteen possible system configurations. Evaluating all the material performance of all the possible configurations in terms of recovery and grade yields the graph shown in Figure 3-7.

The figure shows a wide variety of separation performance between the different system configurations. Some configurations provide an improvement over the performance of a single step identical to those used in the system. (The performance of a single step here would be, in terms of recovery and grade,  $R^T = 0.85$  and  $G^T = 0.85$ .) In some cases, the performance of a single step would be an improvement in all aspects. While some of these poorly performing system configurations are obviously inferior by inspection, the selection of the most useful configuration for a given separation goal from these sixteen options could be challenging.

Given the calculated system performance for these systems of two steps in Figure 3-7, we are interested in which of these system configurations has the best material performance. Overall, three performance point exist that provide better performance than any of the other sixteen. These three configurations are diagrammed in Figure 3-8. In these diagrams, upward-pointing, solid arrows represent primary output streams, while downward pointing, dashed arrows represent secondary output streams.

There are tradeoffs between these three systems. Essentially, for any system material performance goal, one of these three systems represents the best overall material performance possible with these two identical steps. The configuration in Figure 3-8a has the highest recovery, but a lower grade than either (b) or (c). Figure 3-8c has the highest grade. The configuration in Figure 3-8b has higher grade than (a) but higher recovery than (c). For any given recovery, one of these three systems represents the

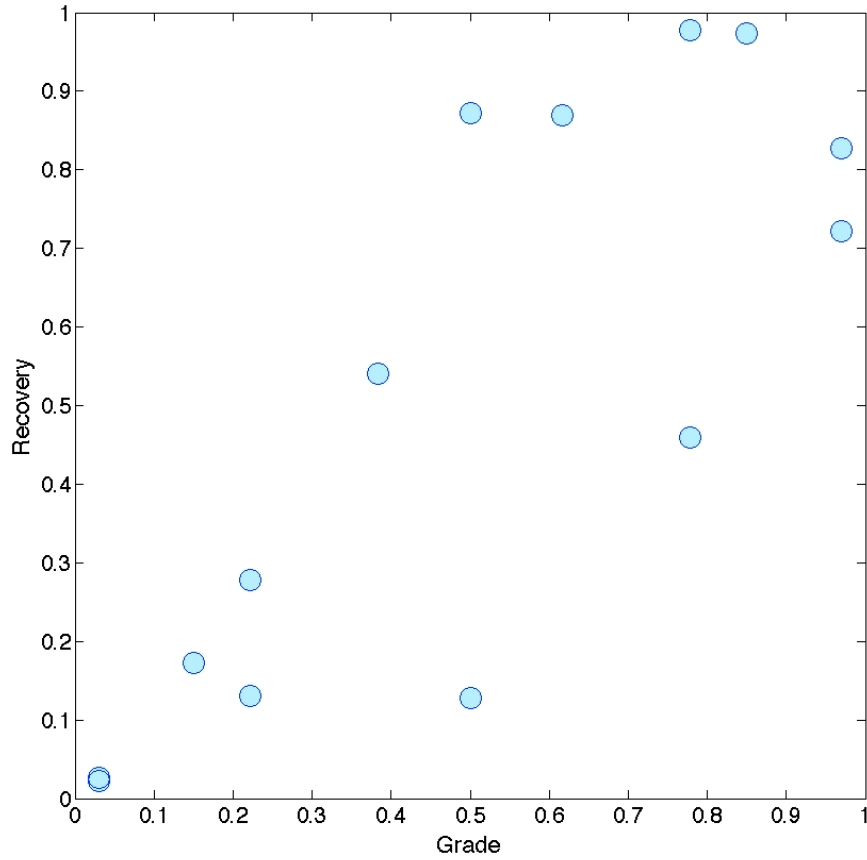

Figure 3-7: Separation performance for the sixteen possible configurations of two identical separation steps, given as recovery and grade.

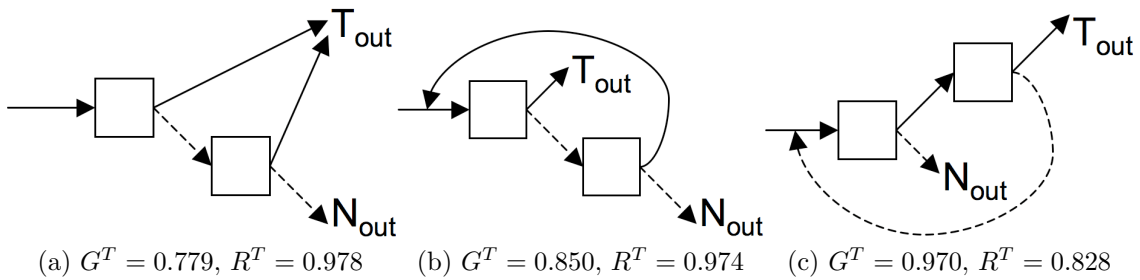

Figure 3-8: Configurations of two identical steps with superior performance.

highest grade at that goal, and for any given grade, one of these three systems represents the highest recovery at that grade. Taken as a set, these three configurations represent an envelope of optimal systems for these process parameters, a concept that will be discussed in Section 3.3.4.

The exact selection of separation system configurations that compose the envelope of optimal processes for two steps is dependent on the individual process parameters. However, the systems represented in Figure 3-8 are representative of the typical optimal system configurations.

### 3.3.3 Optimal Systems of Three Identical Steps

As shown in Section 3.3.2, the options for configuring a system are surprisingly numerous. Adding additional steps increases the number of possible systems. Using the same parameters discussed in Equations 3.11, we can consider systems of three identical separation processes, where  $r_1 = r_2 = r_3$  and  $q_1 = q_2 = q_3$ . Extending the example discussed to systems of three identical steps yields 304 possible system configurations

Again, we can investigate the separation properties of these configurations using the binary separation system model. Evaluating all the material performance of all the possible configurations in terms of recovery and grade yields the graph shown in Figure 3-9.

In this case, there are nine different systems included in the set of optimal system configurations for these process specifications. Again, these processes have tradeoffs between the system goals of grade and recovery.

### 3.3.4 The Envelope of Optimal Systems

As demonstrated in Sections 3.3.2 and 3.3.3, for a given set of separation processes, there may not be a clear cut single best system configuration. Instead, there may be a set of process configurations that represent options with tradeoffs between system goals. These sets of systems form an envelope of performance that other system con-

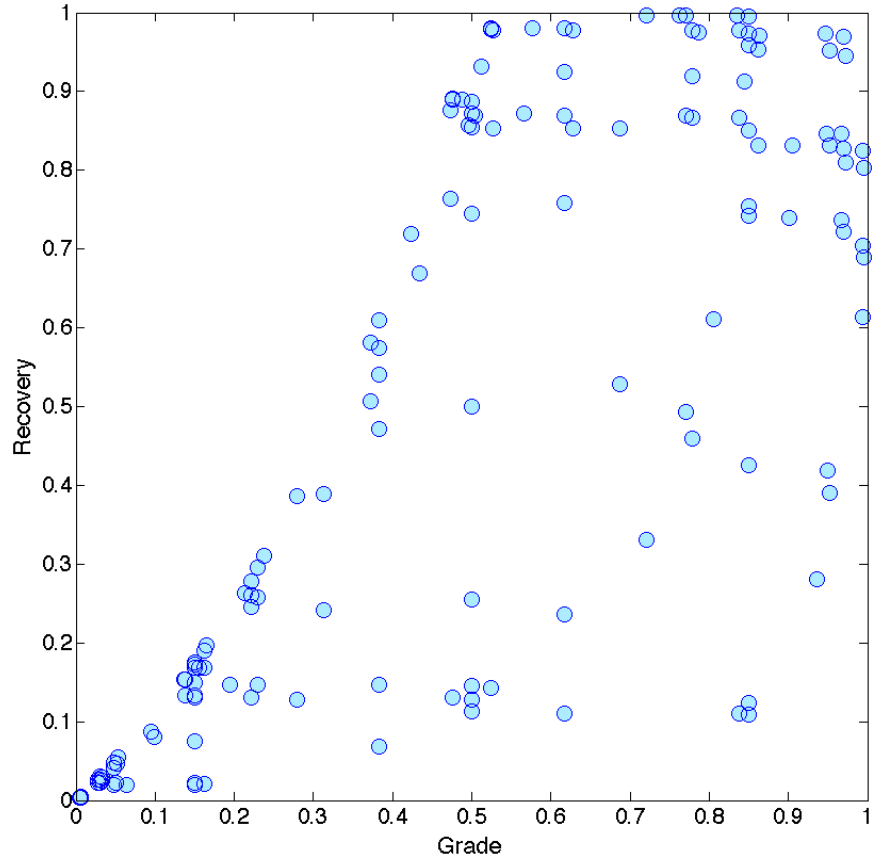

Figure 3-9: Separation performance for the 302 possible configurations of three identical separation steps, given as recovery and grade.

figures of the same number of steps cannot approach. As the number of steps in consideration increases, the performance of the envelope of optimal system configurations improves. The envelope of optimal performance for systems of one to four stages using the separation performance data and input material concentration given in Equation 3.11 is shown in Figure 3-10. The optimal performance envelope advances as the number of identical separation stages in a system configuration increases from one to four, as shown in the figure. This trend continues for systems with increasing numbers of stages, approaching but never reaching the ideal separation result of recovery and grade both unity.

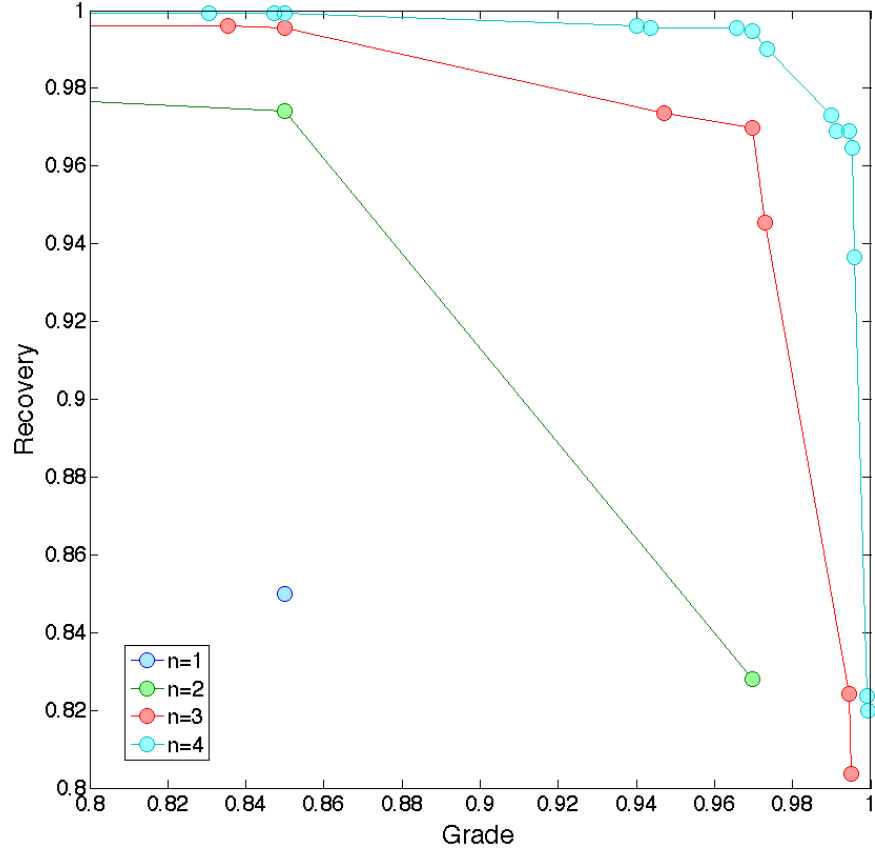

Figure 3-10: Envelope of optimal system configurations for systems of 1, 2, 3, and 4 separation steps.

### 3.3.5 Other Problem Types

In addition to investigating the performance of configurations of identical steps, the binary separation model can be used to investigate other theoretical and realistic system problem types. There are a wide variety of problem types, which include the configuration of a fixed set of non-identical steps, the selection of process operational parameters for a fixed configuration, and the configuration of steps in conjunction with the selection of operational parameters. An example of this last type of problem in a binary separation system is given in Section 6.1 for the separation of PET and aluminum shred in the beverage container recycling industry.



# Chapter 4

## Extending to Multi-Material Models

Binary material separation system models, as discussed in Chapter 3, can capture and predict the behavior of separation systems where the material streams in the system can be conceptually divided into two groups. In some systems, this is the case, but many material separation systems treat streams with multiple distinct material components. Examples of multi-material streams that are commonly separated include curbside household recycling, plastics streams, materials streams originating with specific products, some mining streams, and chemical process streams. While in many cases, systems processing binary materials may have a few steps, multi-material separation systems typically have more separation stages, in order to capture and purify more material streams. It is not unusual for a working multi-material separation process to have ten or more steps, as shown by the example of a curbside commingled recycling system shown in Figure 4-1.

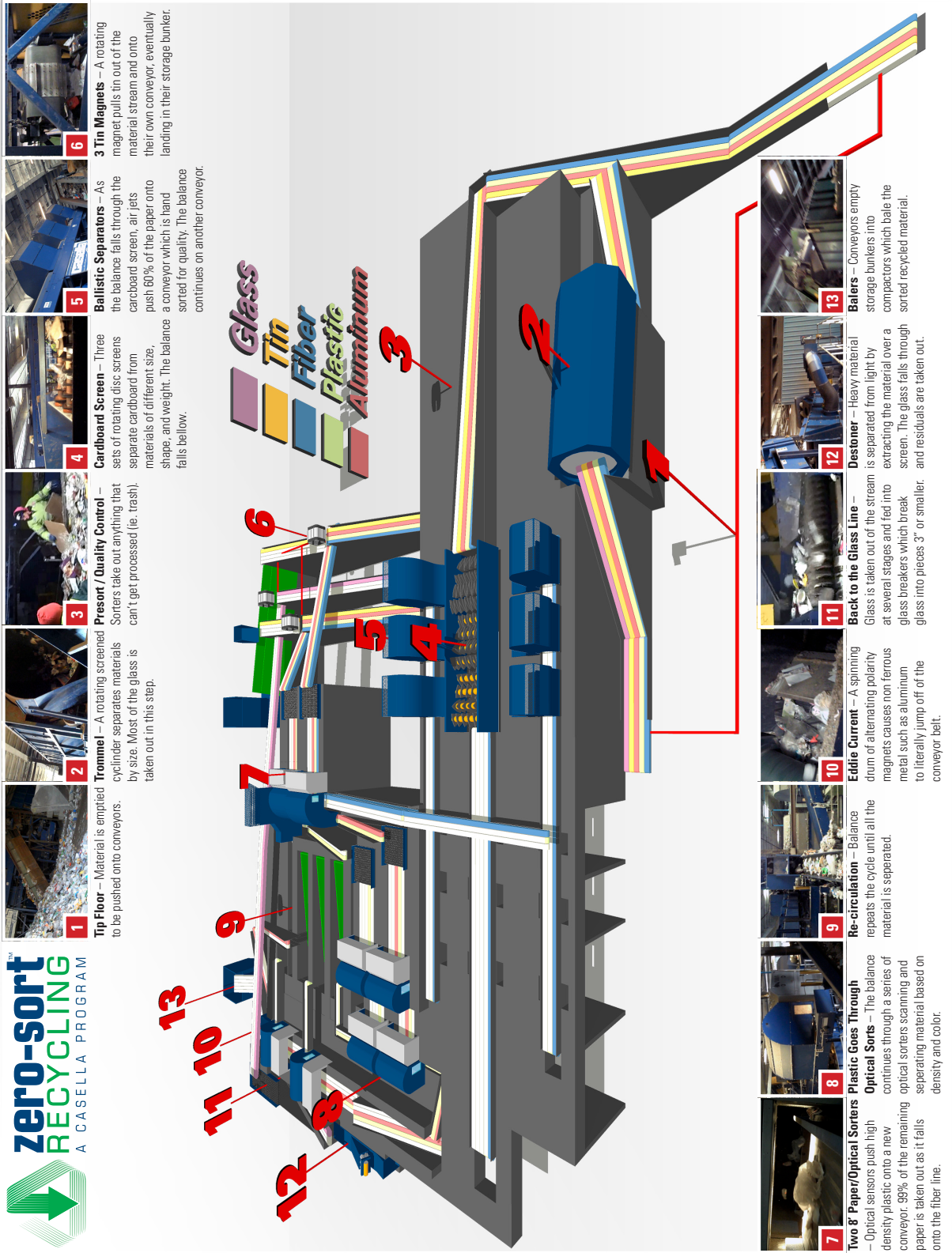

Figure 4-1: Zero-Sort commingled curbside recycling facility diagram [19].



Modeling these multi-material separation systems requires capturing additional effects that are not described in binary separation models. The two main features are that the flow of multiple materials must be followed, and that the models for separation process performance must describe and discern between multiple materials. This chapter discusses the extension of the binary material separation system model as described in Chapter 3 to multiple materials. Previous modeling efforts that examine multiple material systems are discussed and contrasted with the binary separation system model.

## **4.1 Separation Performance Parameters for Multiple Materials: Extending the Bayesian Model**

As mentioned in the introduction to this section, one of the important components of multi-material separation system modeling is performance modeling for individual processes separating multiple materials. The Bayesian material separation model considers mixtures of two material components being separated into two output streams. Multi-material process may handle multiple materials into multiple output streams.

### **4.1.1 Previous Multi-Material Models**

Models for multi-material separation processes have been created and used in specific separation system models. Some of these models are very specific to certain types of process, while others can be applied to any type of separation process.

Froth flotation models have often considered the flotation of multiple mineral species or particle types. These models, rather than specify the output performance of the processes in terms of material fraction diverted, typically instead specifying the flotation rate, which is then used to calculate the material diversion based on time the quantity of a given species input into a separation stage [104, 83, 24]. These models for froth flotation are complex physical models that can include a wide variety of parameters, such as the influence of drainage rate between phases, cell geometry,

particle sizes, and more, which are then incorporated into calculating the flotation rate [121, 102].

A non-process-specific model for multiple material diversion is the transformation matrix model [162]. This is a descriptive model based on observed data, much like the Bayesian material separation model. The model specifies the diversion of particles by a process into one of any number of output streams, based on particle size and liberation. Similar models have been used for mineral processing systems [84]. While the transformation matrix model can be used to describe the performance of an individual process, it is also used to describe the performance of small systems bundling together several separation processes, processes and systems that naturally generate multiple material outputs, such as smelting processes that produce slag and gasses as well as metals, and even systems that divert products and parts as opposed to materials, such as dismantling processes that capture reusable parts, parts with desirable materials, and materials and parts to process for further material extraction.

Other material models discussed in Section 3.1.1 on binary material separation system modeling can also be applied to multi-material separation systems. For example, the strategic material bulk planning technique is intended for use with multiple materials [151]. The flowsheet techniques described are commonly used in industry for evaluating multi-material systems.

#### **4.1.2 Material Separation Matrix Model**

While models for multi-material separation process performance exist, they present complications that make them difficult to use in a basic separation network model. Process specific models, like those mentioned in Section 2.2.2 and above, can only be applied to very specific processes, and require a detailed understanding of the process, its parameters, and the physical properties of the input stream that correspond to the physical parameters of the models. These models require detailed data about the processes and input material streams, physical understanding of the process, and can only be applied to the given process.

The transformation matrix model, as described above, also has challenges with

widespread application [162]. The level of measured performance data required to create a transformation matrix for a given process may be prohibitive. The number of transformation matrices required for a given process or system is dependent on the scenario, which is inconvenient for inclusion in network models. This is a function of assumptions about the units being modeled. When focusing on separation processes, very few examples of separation processes with more than two outputs exist, and thus the added complexity of the transformation matrix model may be unnecessary to capture the performance of separation processes.

For many separation processes, a simpler model can provide a clearer view of process performance. Here we present the material separation matrix model, which captures the diversion of multiple materials into two output streams with one matrix of performance parameters. This model mirrors the Bayesian material separation model described in Chapter 2, in that it specifies the recovery of each material in the system independently from the other materials. Instead of a single parameter for each material,  $a$ , a separation parameter is specified for each of the two output streams, the primary and secondary output streams  $p$  and  $s$ , for any given separation process,  $i$ . These two parameters,  $R_{i,p}^a$  and  $R_{i,s}^a$ , represent the recovery rate of material  $a$  into the primary and secondary output streams of process  $i$ . So, in the case of a material  $a$  of mass flow rate into process  $i$  of  $m_i^a$ , the material flow rate of material  $i$  into the primary output stream is then  $m_i^a R_{i,p}^a$ , and the material flow rate of material  $i$  into the secondary output stream is then  $m_i^a R_{i,s}^a$ . A complete description of a process under this model includes a recovery rate for each material being processed for each of the two output streams. This set of parameters can be arranged into a two column matrix, as shown in Table 4.1. Table 4.1a gives an example of the recovery rate parameters required for a process treating three materials in its input stream. The mathematical requirement for a separation process is that the sum of each row must be one, that is,  $R_{i,p}^a + R_{i,s}^a = 1$ , representing the diversion of the total incoming mass flow rate of material  $i$  into the two output streams. There is no restriction on the totals of the columns, representing the recovery rates to one output stream. Table 4.1b gives example values that could satisfy these conditions.

Table 4.1: Material separation matrix for a process processing three materials.

(a) Format of a material separation matrix.

	Primary Output	Secondary Output
Material 1	$R_{i,p}^1$	$R_{i,s}^1$
Material 2	$R_{i,p}^2$	$R_{i,s}^2$
Material 3	$R_{i,p}^3$	$R_{i,s}^3$

(b) A example material separation matrix.

	Primary Output	Secondary Output
Material 1	0.91	0.09
Material 2	0.80	0.20
Material 3	0.14	0.86

Similar to the formulae detailed in Equations 2.3 and 2.4, for each material  $a$  entering process  $i$ , we can define the separation parameters in terms of the material flow rates into the process and out into the primary and secondary outputs.

$$R_{i,p}^a = \frac{m_{i,p}^a}{m_{i,in}^a} \tag{4.1}$$

$$R_{i,s}^a = \frac{m_{i,s}^a}{m_{i,in}^a} \tag{4.2}$$

As in the case with Bayesian material separation, material performance data collected through experimental trials or through physical modeling can be analyzed using these simple equations to determine separation performance. Again, separation parameter values are specific to the exact separation process and material mixture used in the experimental trial or simulation.

Unlike the case of Bayesian material separation, the desirable values of  $R_{i,p}^a$  and  $R_{i,s}^a$  are not necessarily clear. The ideal values will depend on the function of the process, the other processes available for treating these materials, and the overall system goals. In the abstract, in a typical separation system attempting to separate out each material as purely as possible, a desirable process would sort all of each

material into one output stream or the other, that is, one of  $R_{i,p}^a$  and  $R_{i,s}^a$  for each  $a$  would be 1 and the other would be zero. Having at least two of the materials have opposite values of  $R_{i,p}$  and  $R_{i,s}$  is desirable, to create at least one separation. Split material streams, where  $R_{i,p}^a \approx R_{i,s}^a \approx 0.5$ , require either that processes upstream of process  $i$  remove all of material  $a$  before it reaches that process, or that multiple processes downstream of process  $i$  need to capture material  $a$ . In general, there are many different conditions on what a “good” separation matrix could look like, and the makings of an ideal process is dependent on its context in a system.

## 4.2 Networks Processing Multiple Materials

As discussed in Chapter 3, separation processes are linked together into systems to meet ultimate separation goals. While with some binary separations can be achieved using one separation stage, single step systems are rare in the case of multi-material systems. Conceptually, using two-output separation steps, the minimum number of separation steps to completely separate  $n$  materials each into their own designated output stream is  $n - 1$  [32]. In practice, for some cases, a low number of separation steps per captured material are utilized, as with the end-of-life vehicle processing system diagrammed in Figure 4-2. In other cases, as with the curbside recycling system shown in Figure 4-1, multiple stages of separation are used to separate and purify each material stream.

Given the need for a typical multi-material separation system to combine multiple separation stages, modeling the interaction between multiple separation stages processing multiple materials is an important tool for understanding multi-material separation. The modeling approach outlined here mirrors that discussed in Chapter 3. A network of directed edges is used to model the connection of separation stages and system inputs and outputs, while the separation matrix model as discussed in Section 4.1.2 is used to model the flow of materials through individual process outputs. Again, as with the binary separation systems, mass balance equations are used to tie together the information from the process network and individual process

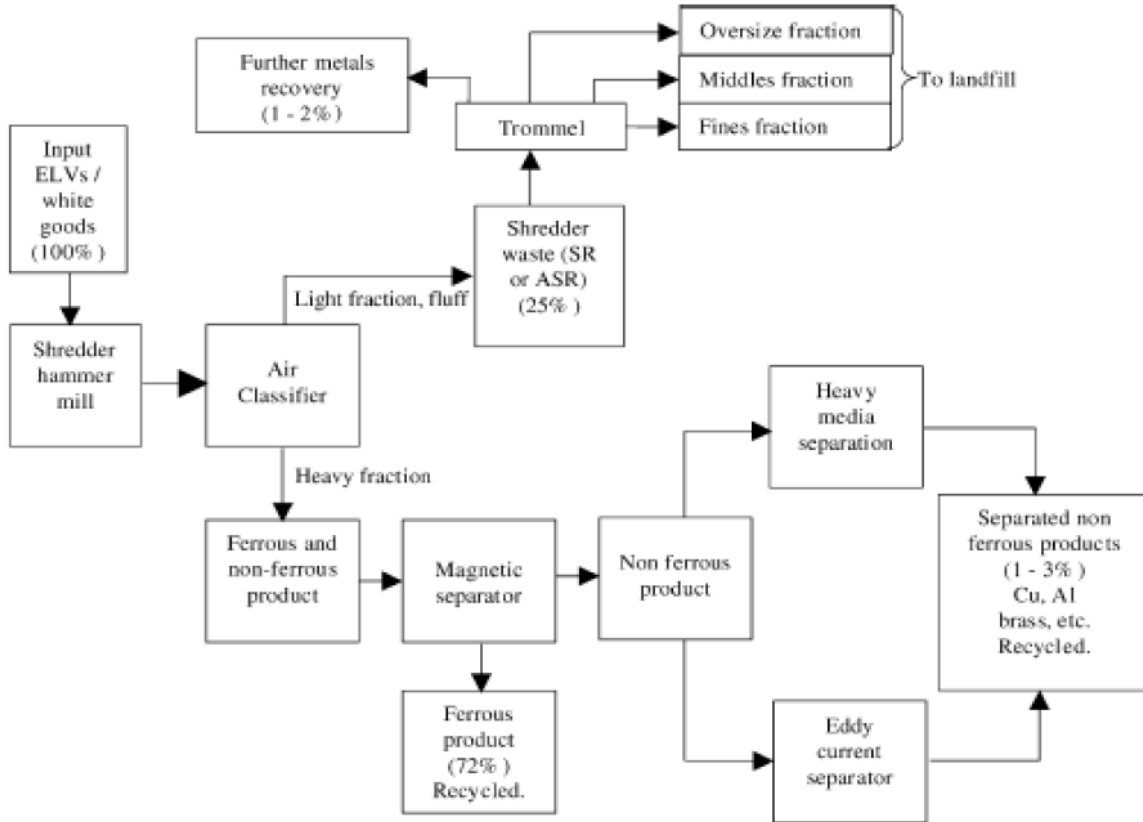

Figure 4-2: Flow sheet diagram of a metals separation plant with mass flow rate fractions [98].

performance to provide a description of system performance.

#### 4.2.1 Routing Multiple Materials

As in the case of systems of binary separation processes, systems of stages processing multiple materials can offer an increase of performance over individual separation steps. A model of the network of separation steps is critical to analyzing the performance of a separation system. Based on the model of separation processes given in Section 4.1.2, a network model similar to that described in Section 3.2.2 can be used for multi-material systems as well.

The key similarity between the Bayesian Material Separation model and the separation matrix model is the distribution of output materials into two output streams, identified as the primary and secondary output. In both cases, separation perfor-

mance parameters are defined in terms of these two output streams. Thus, similar definitions of connections can be used in the multi-material case.

Again, we can define the set of separation stages in a multi-material separation system as  $S$ , the set of external system inputs as  $I_{ext}$ , and the set of external outputs,  $O_{ext}$ . The connections between each stage's output and the stage in the system it is directed toward are represented as a directed edge connecting the two. The same restrictions on the direction of outputs apply as in the case of binary separation systems, and the sets of these directed edges are defined the same way. The output of each system input in  $I_{ext}$  is assumed to be directed to a separation process in the system. The set of directed connections from the external inputs is designated  $E_{ext}$ . Both the primary and secondary outputs of each separation step in  $S$  are assumed to be directed at other processes within the system or to system outputs. For organizational purposes, the connections from primary and secondary outputs are divided into separate categories,  $E_p$  and  $E_s$ . Restating mathematically,

$$E_{ext} = \{(l, i) \mid \forall l \in I_{ext} \text{ where } i \in S\} \quad (4.3)$$

$$E_p = \{(i, j) \mid \forall i \in S \text{ where } j \in S \cup O_{ext}\} \quad (4.4)$$

$$E_s = \{(i, k) \mid \forall i \in S \text{ where } k \in S \cup O_{ext}\} \quad (4.5)$$

The union of these three sets of connections,  $E = E_{ext} \cup E_p \cup E_s$ , describes a complete system topology, representing all the stages within the separation system and the connections between these steps.

These equations are identical to Equations 3.2, 3.3, and 3.4. Essentially, process routing works identically as in the case of binary separation network routing, again due to the output structure of binary and multi-material processes.

## 4.2.2 Multi-Material Mass Balance Equations

As in the case with binary material systems, described in Section, 3.2.3, a network model expresses the material flow pattern within the multi-material system, the exact quantities of the material flow within the system are determined by the separation

performance of the individual steps and the amounts of the input flows. Combining these pieces of information with the network model can yield mass flow balance equations that describe the balance between the mass flow through a process and the streams directed into it through external inputs or system process outputs. Again, simplifying assumptions are used when creating and solving these equations. The most important are that the system is assumed to be operating in steady state, with no storage in the network or processes, and with fixed operating parameters. Similar to Equations 3.5 and 3.6, the mass flow of each material from each external input is a known fixed rate given as

$$m_l^a = a_l \quad (4.6)$$

where  $a_l$  is the mass flow rate of material  $a$  entering the separation system from external input  $l$ . For separation processes within the system, in  $S$ , or system outputs, in  $O_{ext}$ , the flow of material through that stage must be balanced against the mass flow into the system from other sources, including external system inputs and other process outputs. Similar to Figure 3-6, Figure 4-3 shows a separation step with all types of possible inputs. Material streams from external outputs are assumed to be fed whole into separation processes in  $S$ , while parameters from the separation matrix model are used to calculate the fraction of material of a given type flowing along primary and secondary output connections to that process.

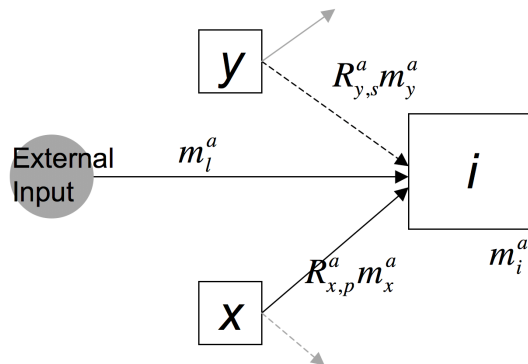

Figure 4-3: Single multi-material stage (separation process or system output) with all possible types of input connection for material  $a$  flow.



Individual mass flow balance equations are created for each separation stage or system output in the set  $S \cup O_{ext}$ . For each individual stage in that set, the mass flow of each type is balanced against the incoming flows from external inputs and primary and secondary outputs from separation stages directed at that stage. The balance for material  $a$  in stage  $i$  is shown in Equation 4.7. As in the case of Equations 3.7 and 3.8, all external input connections to the stage in  $E_{ext}$ , all primary output connections to the stage in  $E_p$ , and all secondary output connections to the stage in  $E_s$  are included in the mass balance. The mass of each material flowing from each separation stage connected to the current stage through  $E_p$  or  $E_s$  is calculated using the upstream process's separation efficiency for that material. In this case, the separation efficiencies are taken from the separation matrix for each process.

$$m_i^a = \sum_{(l,i) \in E_{ext}} m_l^a + \sum_{(x,i) \in E_p} R_{i,p}^a m_x^a + \sum_{(y,i) \in E_s} R_{i,s}^a m_y^a \quad (4.7)$$

Combined with a complete set of external material input equations of the form shown in Equation 4.6, these equations form several systems of linear equations, one for each material flow. These equations create a complete description of material flow in the binary material separation system.

### 4.2.3 Solution Techniques for Multi-Material Systems

Solution techniques for these linear systems of equations describing the material flows in multi-material separation systems are the same as for systems of equations describing the performance of binary material systems, as described in Section 3.2.4. The same conditions for solvability enumerated in that section apply here; each separation stage must be in a path from an external input to an external output, and no stage may have self-directed outputs. Given these conditions, basic linear system techniques can be applied.

## 4.3 Modeling Theoretical Multi-Material Systems

Modeling multi-material separation systems presents a greater challenge than modeling binary separation systems. Meaningful examples are necessarily more complex. Metrics for systems processing multiple materials are not as clear to select as for binary separations. In essence, added materials bring added complexity. The utility of the multi-material separation model is demonstrated here by providing meaningful analysis of these types of systems.

The multi-material system examples presented here consider simple example systems processing three materials, with either two or three separation stages. For added simplicity, the stage performances and input mass flow rates are assumed to take a similar forms for each material. Only one input material stream is used, and that input material stream is an equal mix of the three input materials, material 1, material 2, and material 3. That is,

$$m_{in}^1 = m_{in}^2 = m_{in}^3 = 1/3$$

The processes here are given similar, but not identical performances. We create an  $a$ -selecting process, where  $R_p^a = 0.9$  and  $R_s^a = 0.1$ , and for all other materials  $b$  where  $b \neq a$ ,  $R_p^b = 0.1$  and  $R_s^b = 0.9$ . An example in our system would be that a 1-selecting process would have material separation efficiencies defined as

$$\begin{array}{ll} R_p^1 = 0.9 & R_s^1 = 0.1 \\ R_p^2 = 0.1 & R_s^2 = 0.9 \\ R_p^3 = 0.1 & R_s^3 = 0.9 \end{array}$$

Using the multi-material separation system model as outlined in this chapter, we can evaluate the performance of systems consisting of these types of steps. First, we consider the configuration of a system of two multi-material separation stages, a 1-selecting process and a 2-selecting process. Three output streams are considered, one collecting each of the three materials. We will label these three outputs as  $M_{out}^1$ ,

$M_{out}^2$ , and  $M_{out}^3$ .

With three output streams, there are many options for evaluating the performance of these systems. In this case, each material is an equal component of the input mixture. If we assume that each component is equally valuable in terms of our separation goal, then each output stream must be included in the overall system performance evaluation. In a real system, the overall captured value of the materials, the total material captured, or specific material goals may be used to create metrics for evaluation. In this case, where we are evaluating theoretical systems with equal materials, material performance is the most important factor of performance. Since all three materials are equally valued and equally distributed, we are interested in the recovery and grade of all three materials, as defined in Equations 3.9 and 3.10. As a substitute for investigating the individual recovery and grade for each material output stream, we can compare the sum of recovery and the sum of grade. The sum of recovery here is defined as  $R_{M_{out}^1}^1 + R_{M_{out}^2}^2 + R_{M_{out}^3}^3$ , where the subscript  $M_{out}^a$  indicates that it is the the recovery for the designated output stream for material  $a$ . The sum of grade is defined as  $G_{M_{out}^1}^1 + G_{M_{out}^2}^2 + G_{M_{out}^3}^3$ . Essentially, each of these sums focuses on the recovery or the grade of the materials in their intended output stream.

With a system consisting of a 1-selecting separation process and a 2-selecting separation process distributing material into three output streams, there are 24 possible configuration options. These configurations are generated by considering all possible sets of connections that can be described using Equations 4.3, 4.4, and 4.5. Configurations that do not comply with the guidelines described in Section 3.2.4 are discarded. These conditions include: no self-directed connections for any process, each process must be on a directional path between a material input and a material output, both of a processes outputs cannot connect to the same stage, and all elements of a system must be connected.

Figure 4-4 shows the distribution of the sum of recovery and the sum of grade for those 24 possible configurations. With three materials and three output material streams, the maximum possible sum of recovery and sum of grade are both 3. In the case of this selection of processes and outputs, there are two configurations that

stands out for having a sum of recovery and a sum of grade both approximately 2.5. These superior configurations are shown in Figure 4-5. While the physical arrangement of the steps and the exact material output performance of these two configurations are not identical, the performance and configurations of these two systems are permutations of each other. The configuration shown in Figure 4-5a could be created using the configuration in Figure 4-5b by switching 1- and 2-selecting processes, 1- and 2-targeting outputs. This switch would create the same effect in the material flow at each stage; the value of  $m_i^1$  at any stage would switch to the value of  $m_i^2$ , and vice versa. These are essentially identical configurations, if we do not distinguish between the materials.

While the configuration of two separation steps might be easy, with effectively 12 choices of separation system when permutations are taken into account, additional separation steps bring added complexity. Next we consider the configuration of a system of three separation processes, one each of a 1-selecting process, a 2-selecting process, and a 3-selecting process, processing the same equal mixture of three materials into three output streams, one for each material. In this case, there are 1872 possible separation system configurations. Again, we measure the performance of these separation systems using the sum of recovery and the sum of grade. Figure 4-6 shows the performance of these configurations, as measured with sum of recovery and sum of grade. The best performing processes, by these metrics, have both sum of recovery and sum of grade of approximately 2.7. Figure 4-7 shows one of these best performing system configurations.

Again, as in the case of the two stage multi-material separation example, there are several systems whose sum of recovery and sum of grade are identical because the systems are permutations of material assignments within the same configuration structure. In each case, there are six permutations of each configuration. Figure 4-7 shows one of the six configurations with identical performance under the metrics of sum of recovery and sum of grade. Unlike the case of the 2-stage process, there are many other options for a 3 process configuration that might appear reasonable upon casual inspection. Several other configuration forms provide sum of recovery

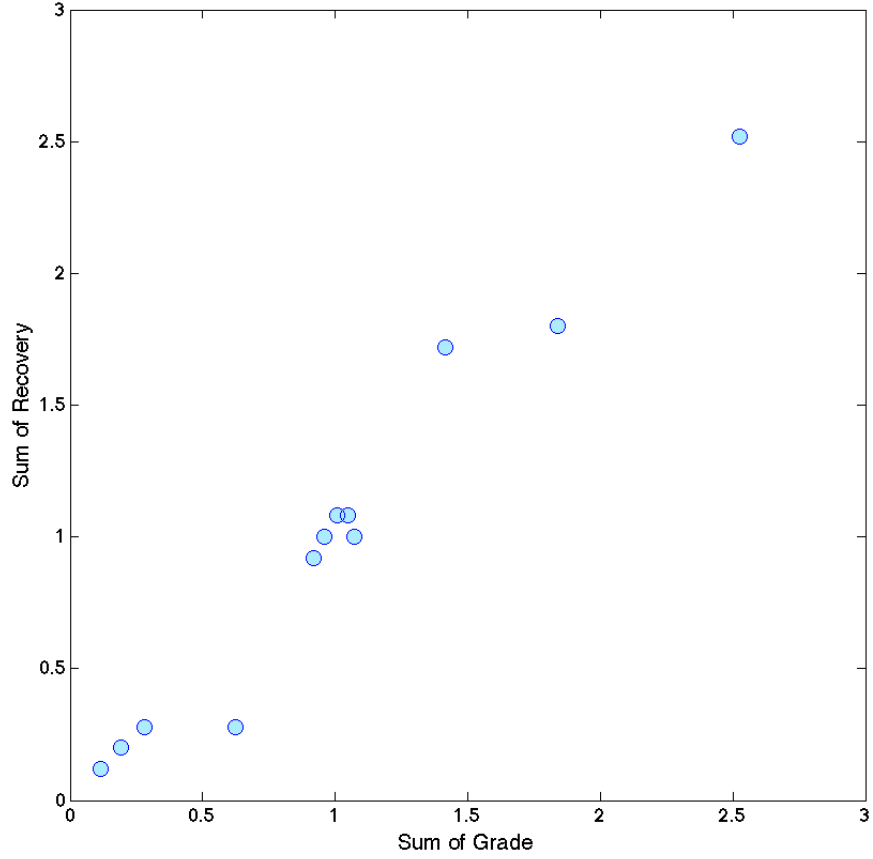

Figure 4-4: Separation performance for the 24 possible configurations of a 1-selecting process and a 2-selecting process, given as sum of recovery and sum of grade.

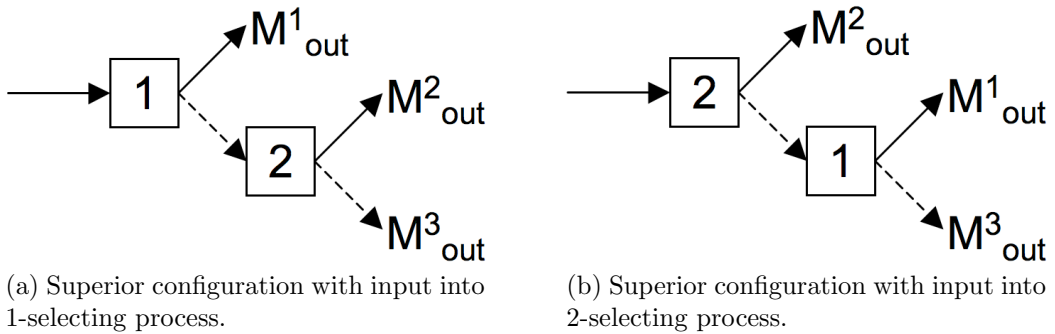

Figure 4-5: Configurations of 1-selecting and 2-selecting processes with superior performance.

and sum of grade both above 2.5, as shown in Figure 4-6. Many other configurations have much poorer performance.

The most effective separation system configurations shown in Figures 4-5 and 4-7 are logical choices for configurations, confirming the findings of the multi-material separation system model. However, as systems of separation processes include more stages and more materials, their complexity rises rapidly. Even in the case of the three stage system depicted in Figure 4-7, there are alternate configurations that have approaching performance that would be identified as logical options. Evaluating multiple configurations of the same set of processes provides a way to compare the performance of these processes. Other problem types, as discussed in Section 3.3.5, can also be approached for multi-material systems using multi-material modeling as outlined in this chapter.

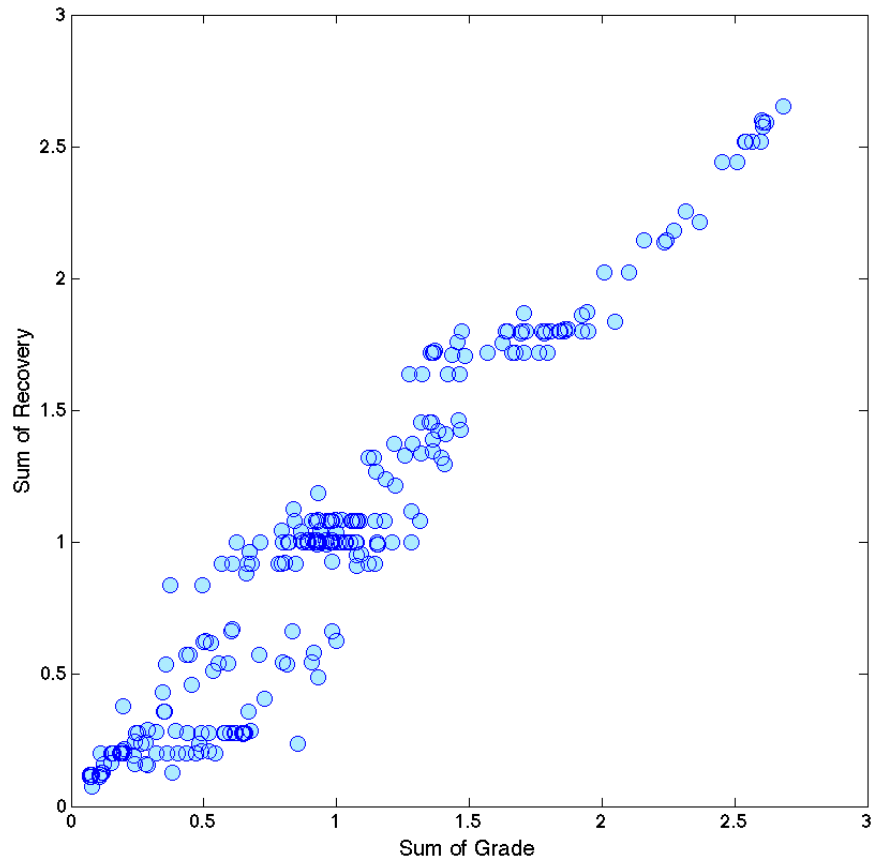

Figure 4-6: Separation performance for the 1872 possible configurations of a 1-selecting process, 2-selecting process, and 3-selecting process, given as sum of recovery and sum of grade.

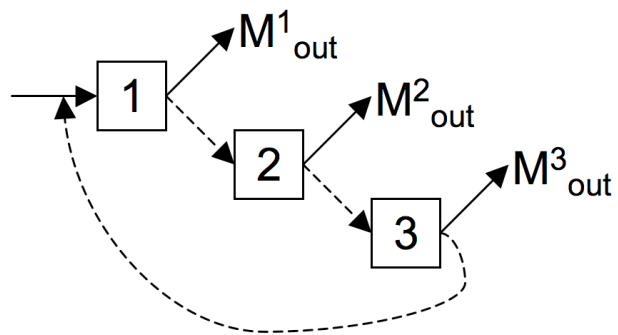

Figure 4-7: Configuration of 1-selecting, 2-selecting, and 3-selecting processes with superior performance.





# Chapter 5

## Modeling Realistic Material Separation Systems

A wide variety of material separation systems are used across many industries. Many different separation processes are combined in these systems. Some processes are used on specific material streams, but others are used in multiple industries processing a wide variety of material mixtures. The combination of these separation processes into systems in conjunction with other manufacturing system components such, as conveyors, storage areas, and balers, can affect the separation properties and behavior of the systems. Accurately modeling the real world performance of separation systems with the material separation models presented in Chapters 2, 3, and 4 requires simplifying their descriptions to a more basic level, while still capturing the essential system behavior. The complicating factors, and strategies for including their effects in models, are discussed in this chapter. One complexity already encountered in Chapters 3 and 4 is the difficulty in describing the overall performance in a system in a meaningful way. This chapter specifically focuses on system metrics as a necessary component of modeling.

## 5.1 Complexities of Real Systems

Capturing the performance of real systems using a basic material separation system model requires simplifying complex behavior to fit the parameters of the model. There are a wide variety of complicating factors, and each has a different effect on system performance and the modeling of that performance. The factors addressed in this section include manufacturing system features, general categorization and selection of processes, and variation in separation processing performance.

### 5.1.1 Manufacturing System Features

The main focus of the binary material separation system and multi-material separation system modeling techniques described in Chapters 2, 3, and 4 is the material performance of the system, as based on the configuration of separation processes and their separation performance. However, these separation systems are also manufacturing systems, and while the focus of our analysis of separation systems does not focus on the core issues typically considered in manufacturing systems, such as production rate, capacity, inventory, and sensitivity, these types of performance have the potential to affect material performance.

Recycling systems as a whole have been investigated as manufacturing systems. Popular topics for the analysis of recycling systems as manufacturing systems have included profitability [17], environmental impact [76], and managing uncertainty in both the upstream supply chain and the market [63]. Most works on recycling systems as manufacturing systems emphasize the performance of the overall material system, as opposed to the performance of individual recycling facilities.

When investigating the performance of conventional factory systems, a wide range of issues are of concern, including production rate, capacity, inventory, responsiveness, and flexibility. Typically, manufacturing systems are modeled as chains of processes with their own process times, feed rates, and failure states and rates, connected by inventory buffers. Those studying manufacturing systems create models that connect the individual machine performance to the overall system performance [58], but the

key parameters and outputs of these models are different than those of models for recycling separation performance. For example, calculating production rate is a key focus of manufacturing systems analysis, while in the binary material separation system and multi-material separation system modeling techniques production rates are taken as given.

In terms of manufacturing system modeling, recycling separation systems consist of high-uptime, continuously operating machines with rapid process times, connected (typically in a fixed configuration) with little or no buffer space. Essentially, material that flows into a separation system flows out at the same rate, which is determined by the capacity of the separation process machines. Separation systems are built to operate at a certain capacity, and the production rate is primarily determined by that capacity. Inventory within the system is negligible compared to the mass of material being processed. Product requirements change very infrequently and the work-in-progress is re-treatable, making the value loss potential from work-in-progress insignificant. Typically, the effects typically modeled in manufacturing system engineering can be approximated with very simple models in the case of separation systems. For example, separation systems may have components that fail, but separation system designers typically approximate this behavior by assuming a given uptime fraction for the whole system.

On the other hand, some lessons from manufacturing system engineering carry over into recycling system modeling, which we will discuss here. While the parameters for selection are different for a recycling system and a typical manufacturing system, the selection of appropriate processes is important to all manufacturing processes. The sensitivity of the system to variation is also a concern in both manufacturing systems and recycling systems.

### **5.1.2 Process Categorization and Selection**

One challenge in designing recycling systems is the selection of appropriate processes. In many cases, a wide variety of processes can be used to perform the same separation functions. For example, the separation of two different types of plastics

can be approached using several different technologies [42]. Plastic-plastic separations can be performed using wet separation techniques, including froth flotation [3, 147, 149, 124, 148], sink-float processes [150, 43], medium-density dense medium separation [14], air density separation in a variety of configurations [4, 44, 107], electrostatic separation [53, 168, 155, 123, 73], and sense-and-sort processes such as optical and spectroscopic separators [41, 50, 156, 78]. Complementarily, a given processing technology may be used to successfully treat many different material mixtures. For example, electrostatic separation, in addition to treating plastic-plastic separations, can be used to separate conductive metals from plastics [36], for powdered mineral ores [16], or for food processing [21]. The exact configuration of a processing technology varies from material mix to material mix.

The wide variety of separation processes used in recycling systems makes it such that describing the advantages and disadvantages of each process individually would be prohibitive. Instead, some of the major categorizations of processes are discussed. These major divisions include body force based processes as opposed to sense and sort processes, wet and dry processes, and batch and continuous processes.

Separation processes have to use some material property to identify which material is which within the process. One prominent division in process types is between separation processes that use that identifying property to perform the separation, and processes that identify materials using that property but use another mechanism for separating the particles. Most traditional recycling processes, including magnetic separators, eddy-current separators, and density separators, fall into the first category. In each of these cases, a body force is exerted on material particles based on the identifying property. For example, in a magnetic separator, magnetic force attracts ferrous particles, as shown in Figure 5-1, while non-ferrous particles are unaffected. Another example a body force-based separation is float-sink density separation. The input material stream is fed into a floatation medium, often water or a water-based solution, chosen because some of the materials in the input mixture float in that medium while others sink.

In contrast, sense-and-sort processes use property differences to identify material

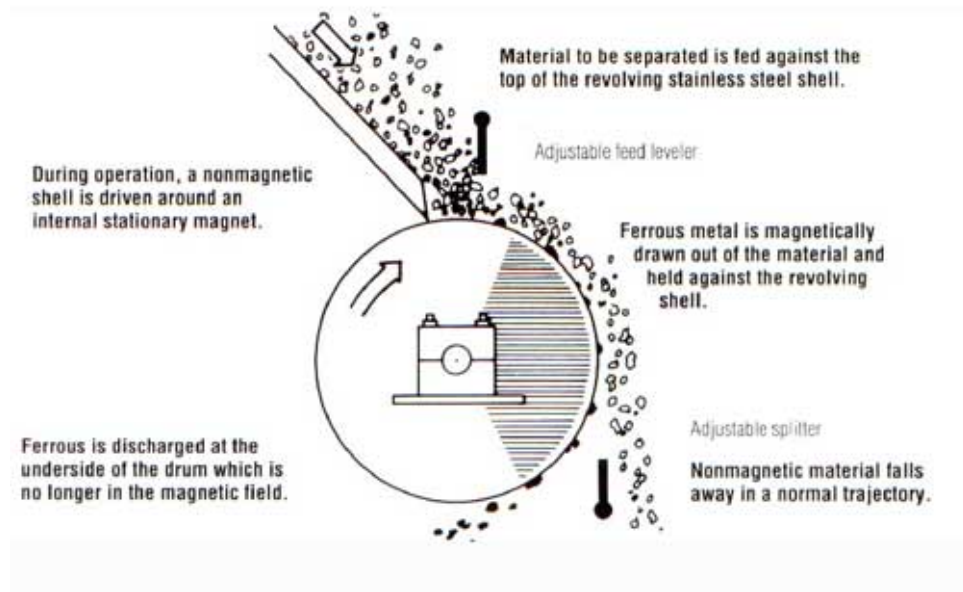

Figure 5-1: Diagram of a magnetic drum separator. From [152].

particles but use an independent mechanism to separate the particles. Sensors such as infrared sensors, metal detectors, or cameras are used to identify the materials, while the physical separation is usually performed by using mechanical paddles and pneumatic jets to deflect the identified materials from the stream. Figure 5-2 shows a sense-and-sort separator that uses both cameras and lasers to identify materials. This process can select for material particles based on color, size, reflectivity, and structure. This allows the process to be used for the capture of a variety of plastics, metals, or even biological materials.

A distinguishing feature of a sense-and-sort system is a control system, often a computer. In a sophisticated machine, such as the multi-sensor process shown above, a computer interprets the sensor readings to determine particle material, tracks the movement of each particle, and triggers the ejection mechanisms. Other sense-and-sort processes, such as near infrared spectroscopy (NIR) processes that identify plastics based on infrared spectrum absorption, operate in a similar manner [111, 88, 127]. Sense-and-sort processes are more complicated and typically more expensive than traditional processes, but allow for separation on properties that cannot be used to effectively generate a body force, such as color or plastic species infrared absorp-

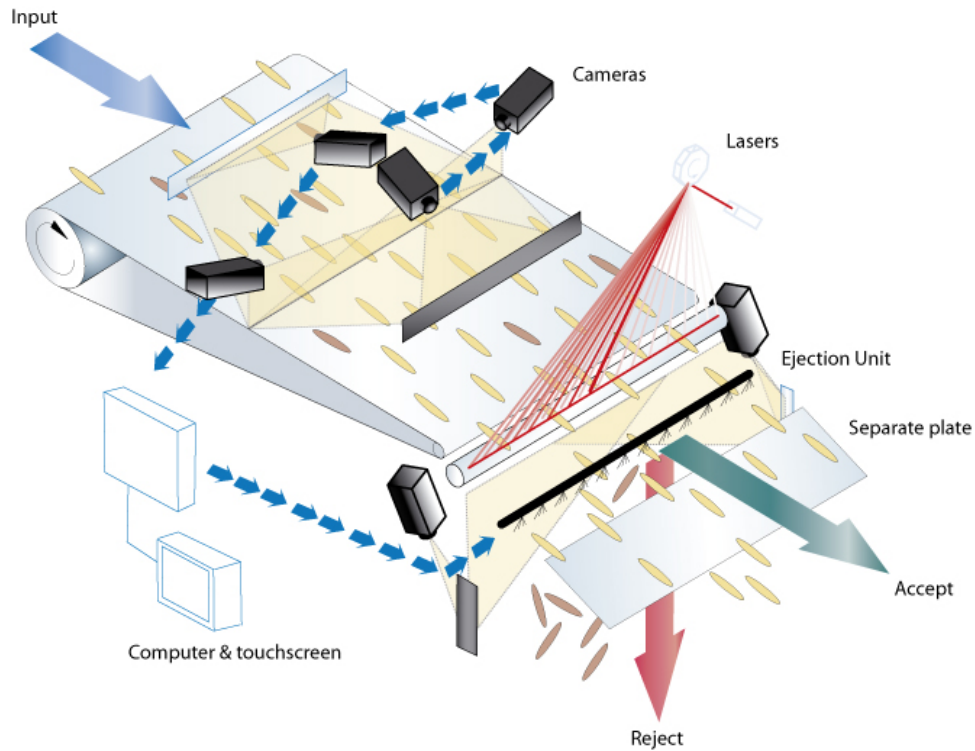

Figure 5-2: Diagram of a sense-and-sort process employing both cameras and laser technology. From [13].

tion, making it possible to automatically capture materials that were traditionally identified by hand, such as individual plastics species and stainless steel.

Other process categorizations include wet and dry separations and batch and continuous processes. In general, we see tradeoffs between these divisions as discussed for body force and sense-and-sort processes. Often the trade-off is between effectiveness and cost. For example, processes that operate wet, such as the medium based separation discussed above, can be very effective for separating materials with similar densities, but require drying the particles for downstream processing and packaging, which has a high energy cost. Dry density separators such as shaker tables and air flow jigs are not as effective for separating materials with similar densities, but have much lower unit processing costs. Process selection for separation systems can be complicated because of these trade-offs.

### 5.1.3 Variation in Processing Performance

The performance of individual separation processes can be specified numerically as described in Chapters 2 and 4. Figure 2-2 gives Bayesian performance data for a variety of separation processes. These experimentally taken measurements reflect the performance of those processes under specified conditions, including a given material mixture, feed rate, and operational parameters. As mentioned in Section 2.2.2, separation parameters for a given process under a fixed set of conditions may not be the same if those conditions change. For example, several studies have investigated the effects of varying separation parameters such as splitter placement or rotational speed, or particle characteristics including target material composition and shape [173, 15].

While many factors can affect separation process performance, their effect can vary. Changing one machine setting or material quality may have immediate effect, while another may need to be varied far outside of its usual range to have an impact. Figure 5-3 shows the effects of varying drum speed on the particle deflection in eddy current separation. (Particle deflection directly affects separation performance.)

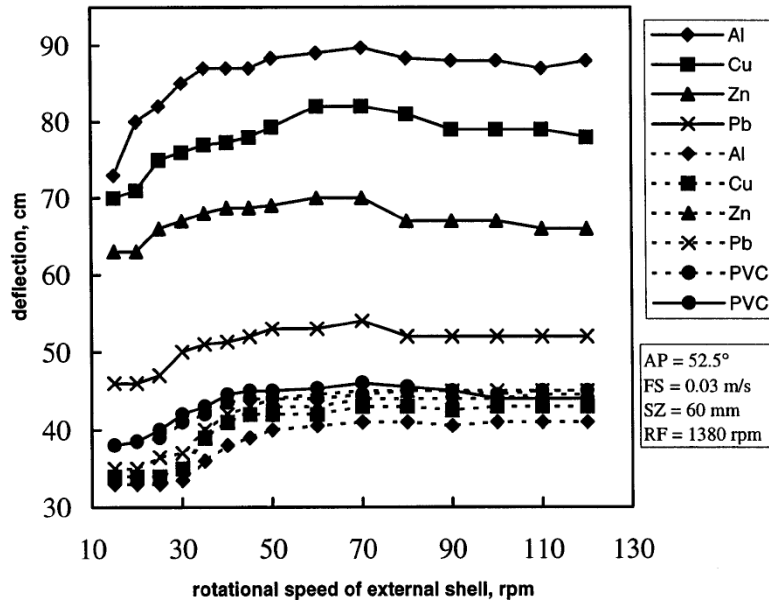

Figure 5-3: Deflection as a function of outer drum rotational speed for various materials, first with high magnetic roller speed, and then with a non-rotating magnetic roller [173].

This graph shows several effects of variation on the deflection of the particles. First, the deflection of particles is different for different materials, all other factors being equal, because the different conductivities and densities of the materials. Next, the graph shows that a non-rotating magnetic roller produces a much lower spread of particle response than a rotating magnetic roller. Perhaps most interestingly, the graph shows the effect of outer drum speed on deflection for each material under fixed conditions. For most of the materials, the deflection with respect to outer drum speed initially rises with speed, and then plateaus. In this plateau the deflection of the particles is insensitive to changing drum speed. For example, for aluminum particles with a high-speed magnetic roller, the particle deflection rises significantly between 10 and 50 rpm for the drum speed, but is relatively level between drum speeds of 50 to 120 rpm. A similar effect is seen on PVC plastic particles. As separation performance of eddy current systems is typified by the relative deflection of the materials, that the deflection of the aluminum and PVC stays the same under the differing drum speed implies that the separation performance for a PVC-aluminum separation would stay the same if the drum speed varied between 50 to 120 rpm.

Some effects of variation on separation can be beneficial to separation system operators, while some are detrimental because of the unpredictability they add to separation performance. Acknowledging and quantifying this variation is important to mitigating its effects. An example property that can effect separation performance is input material composition. Inter-particle interference due to particle overlapping or entanglement and effects of the material on system performance can create an effect where separation process performance varies with input material concentrations. Concentration dependence is an important issue when investigating systems of multiple separation stages, as the concentration of materials varies between stages. If concentration dependence occurs for a process, then applying appropriate separation performance values for different stages may require prior knowledge of the expected concentration at each stage or a numerical analysis of those expected concentrations. The effect of material concentration on separation performance was investigated by the author for three different separation processes, uncovering different ranges of



concentration dependence between these processes and within one process acting on different material mixtures. The three processes investigated are magnetic roller separation, eddy current separation, and static magnetic separation.

Magnetic roller processing, as shown in Figure 5-4, uses the paramagnetic effect in aluminum to separate aluminum shreds from plastics. In the beverage container recycling industry, this process is frequently used to purify polyethylene terephthalate (PET) plastics for use in new containers. Using testing facilities provided by Eriez Manufacturing Co., of Eriez, PA, concentration dependence in magnetic roller processing was investigated for aluminum concentrations in an aluminum/PET beverage container shred in the range of roughly 0.1% to 17%. The author was assisted in this work by Esther Hu. Figure 5-7a shows the results of these investigations. At expected operational parameters including machine settings and material flow rate, magnetic roller processing shows little or no concentration dependence for both  $r$ , the separation efficiency of aluminum, and  $q$ , the separation efficiency of the PET plastic. Under standard operational conditions, this process may be considered concentration independent.

Eddy current separation, as shown in Figure 5-5, ejects high conductivity materials by inducing eddy currents in those materials using rapidly fluctuating magnetic fields. This process is used to separate white and red metals, non-ferrous metals such as aluminum, brass, and copper, from a variety of recycled material streams, including shredded automotive waste and municipal curbside recycling [19]. Using testing facilities provided by Eriez Manufacturing Co., of Eriez, PA, concentration dependence in eddy current separation was investigated for a mixture of aluminum and low-density polyethylene sample squares, roughly 2 inches to a side, operated at typical machine settings. Figure 5-7b shows the separation efficiencies  $r$  for aluminum and  $q$  for low density polyethylene (LDPE) under varying aluminum concentration. While the separation efficiency of the aluminum remains largely unchanged across the range of concentration, the separation efficiency of the LDPE is greatly affected by the increasing concentration. In typical eddy current separation, the desirable non-ferrous metals often carry other material particles into the target material stream.

In this case, the effect is exaggerated by the properties of the test particles, due to their regular, flat shape. In these experimental trials, the aluminum particles carry an increasing fraction of the LDPE particles as the concentration of aluminum increases. Because the aluminum test particles have a strong response, the extra mass from the LDPE particles does not prevent the aluminum particles from clearing the splitter and entering the target output stream. Thus, the aluminum separation efficiency remains high. In this case, the target separation efficiency is not concentration dependent, but the non-target separation efficiency for the LPDE is concentration dependent.

Static magnetic separators are a desktop magnetic separator technology, developed in the Environmentally Benign Manufacturing Laboratory for use in simulating overhead permanent magnet separation. The device uses a permanent magnet array that is lowered over a material mixture, attracting magnetically susceptible particles, typically ferrous metals. The magnet array is then removed and the material accumulated on the magnets is collected as the target output, while the remaining material is collected as the non-target output. Figure 5-6 shows a drawing of the static magnetic separator. Experiments using this equipment were carried out in the EBM lab by Philip Crain, using a variety of material mixtures. Figures 5-7c and 5-7d show the resulting separation efficiencies under varying concentration for a mixture of gray iron and aluminum chips and a mixture of steel and aluminum chips. In both cases, we see a tradeoff in the target and non-target separation efficiencies as the concentration of ferrous particles increases. At low ferrous concentrations,  $r$  is low, and increases with concentration, while  $q$  is high at low ferrous concentrations, and dips as the concentration of ferrous particles rises. The concentration dependent effects are a product of the high particle entanglement in this material mixture. At low ferrous material concentrations, a higher portion of the ferrous particles are entrapped and weighed down by entangled aluminum particles. At higher ferrous concentrations, the intermixed particles have a collectively high enough magnetic susceptibility due to the higher ferrous particle concentration to be collected by the magnet, increasing the ferrous material separation efficiency and decreasing the aluminum separation efficiency. The two different ferrous material and aluminum mixtures have different

separation efficiency curves due to different levels of particle interaction and different magnetic susceptibilities of the ferrous materials. In this case, both of the target separation efficiencies and both of the non-target separation efficiencies are concentration dependent at varying levels.

Across the three different processes and four different material mixtures, material concentration had varying effects on separation efficiencies. In the case of magnetic roller separation, the process is concentration independent under standard operating parameters, while the other processes investigated had some degree of concentration dependence. In any real separation system, the effects of concentration on process performance must be explored in order to accurately characterize the system.



(a) Magnetic roller processing PET plastic and aluminum.

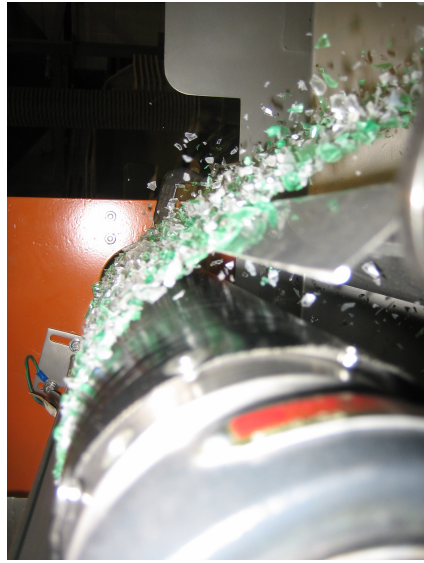

(b) Close-up of splitter.

Figure 5-4: Magnetic roller separator apparatus in operation.



Figure 5-5: Eddy current separator in operation (courtesy of and ©Eriez).

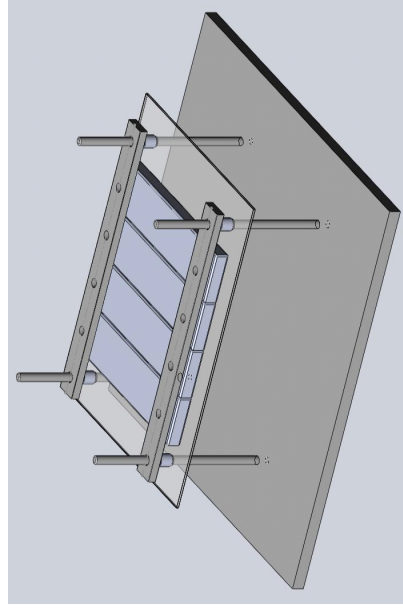
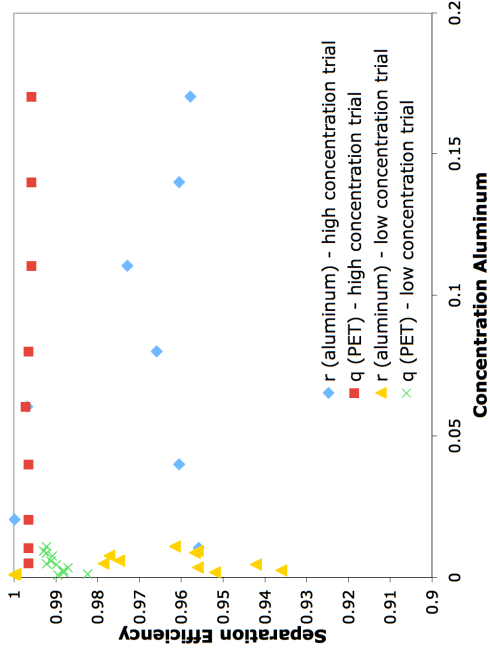
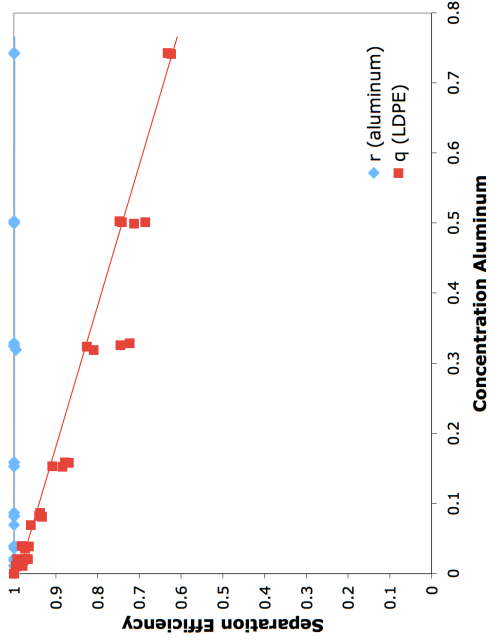

Figure 5-6: Drawing of a static magnetic separator.



(a) Magnetic roller separation of aluminum and PET flake (adapted from [75]).



(b) Eddy current separation of aluminum and LPDE.

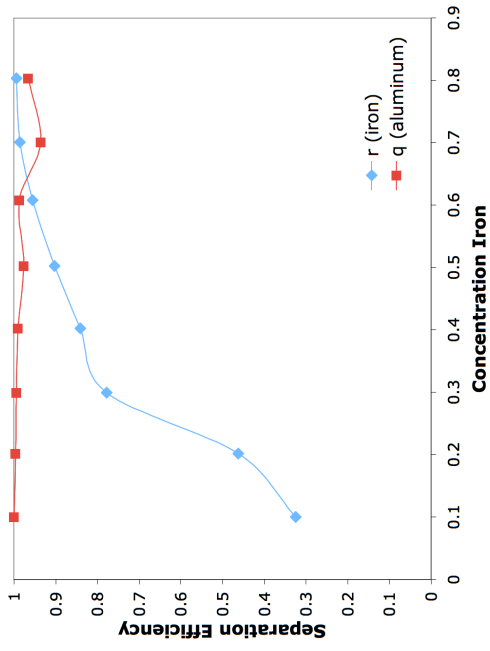

(c) Static magnetic separation of iron and aluminum chips.

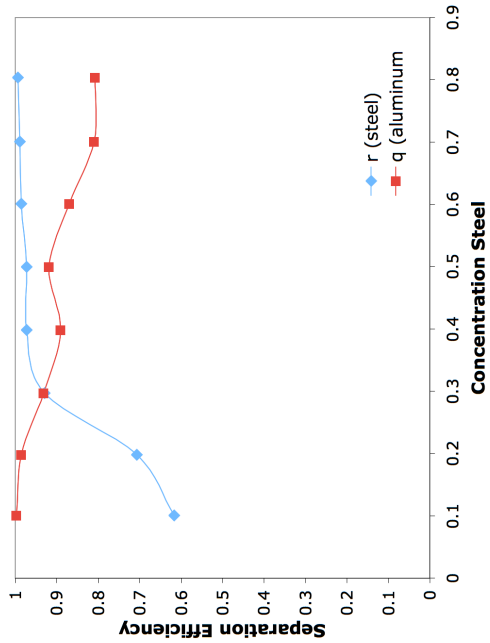

(d) Static magnetic separation of steel and aluminum chips.

Figure 5-7: Separation efficiencies for several processes under varying input material concentration as collected by author.

A good example of the advantage conferred to system operators by some effects of variation on separation performance comes from splitter position variation. The particle deflection given in Figure 5-3 is an average particle deflection for particles; in reality, in many processes particles for continuous distributions of material. Processes such as eddy current separation, electrostatic separation, and magnetic roller separation all distribute material into the physical space of the process output. Eddy current processes, for example, are typically modeled in a two dimensional space, describing the throw of particles away from the rollers [117, 116, 173, 101, 62]. Figure 5-8 shows the simulated throw of aluminum particles in red and copper particles in blue in an eddy current separator. On average, the aluminum particles are thrown further than the copper particles, but the range of trajectories overlaps.

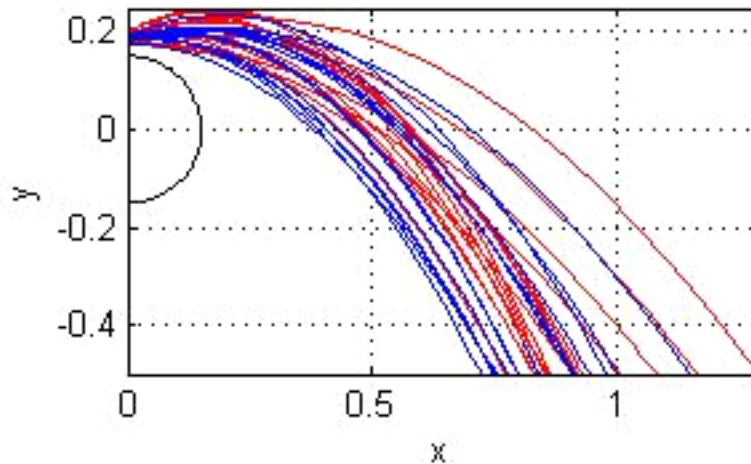

Figure 5-8: Trajectories of aluminum and copper particles in an eddy-current separator. Courtesy Marcello Colledani.

In this two-dimensional model, particles of different types are distributed along a horizontal axis, and are then divided by a physical mechanism, such as a splitter that deflects the material or a set of output collection bins. Figure 5-9 shows the basic concept of this physical distribution for a binary material mixture. The two materials, blue and green, are distributed by the process, then split by a splitting mechanism.

The position of this splitter affects the separation parameters of the process. In this case, the collection area to the left of the splitter would be targeting blue material,

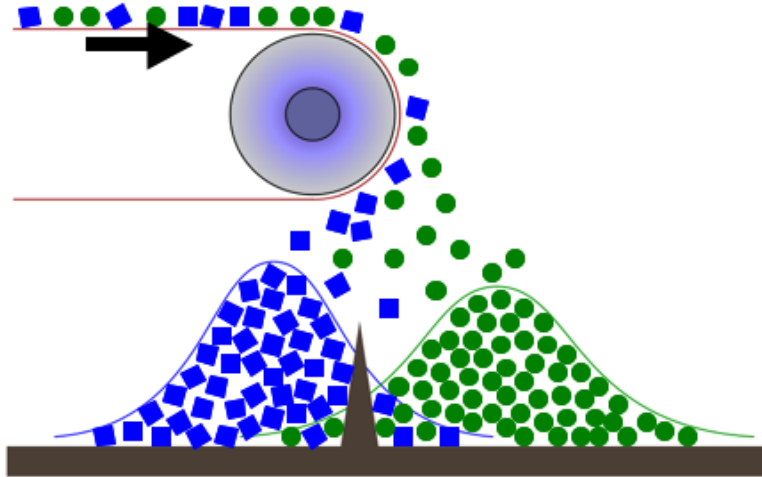

Figure 5-9: A binary material mixture physically distributed by a separation process.

while the collection area to the right would be targeting green material. Moving the splitter to the left would increase the collection rate of the green material while decreasing the collection rate of the blue material, and moving the splitter to the right would have the opposite effect, decreasing the green collection rate and increasing the blue collection rate. In a real system, the effects of changing splitter position is determined by the real distribution of materials in the output. Here we investigate the effects of splitter position on separation parameters for binary systems.

As discussed, many separation processes physically distribute materials into overlapping distributions that are then divided by a splitter or other mechanisms. The shape of these distributions determine the separation performance that can be achieved by the process while it is processing the material mix under those specific operating conditions. The real distributions can take any shape, but a good match for many distributions is a normal distribution [70]. By creating a pair of normal distributions that approximate the real distributions, we can simulate a separation performance  $r$  and  $q$  curve by sweeping a divider between the two distributions. The two distribution curves must be specified in terms of mean and standard deviation. Figure 5-10 shows a set of two normal distributions.

The means and standard deviations of the two distributions in Figure 5-10 are

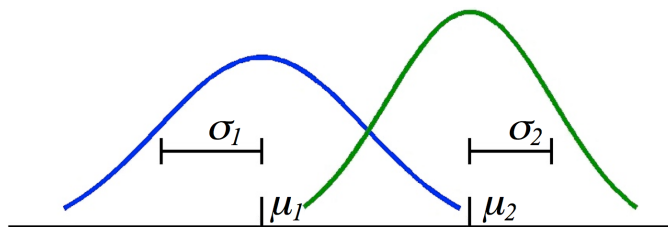

Figure 5-10: Two overlapping normal distributions with specified mean and standard deviation [70].

specified as  $\mu_1$  and  $\sigma_1$ , and  $\mu_2$  and  $\sigma_2$ , respectively. These normal distribution parameters shown in the figure can be estimated for a variety of processes from separation data. Analysis of the data gives a family of pairs of normal distributions that yield the same separation parameters. For convenience of comparison, all parameters are given for a distribution pair with  $\mu_2 - \mu_1 = 1$  for the two normal distributions.

This concept can be used to simulate the performance of a variety of separation processes under varying output stream divisions. Figure 5-11 shows the analysis of three separation processes, the electrostatic separation of PVC and PC plastic [168], the electrostatic separation of ABS and HIPS plastics [168], and the magnetic roller separation of aluminum and PET plastics [70].

The upper graphs in Figure 5-11 show the measured separation performance of the three processes as points. The normal curves used to approximate the material distributions are shown inside the top graphs along with the means and standard deviations of those curves. The solid curve in each case represents the  $r$  and  $q$  curve created by sweeping a divider between through these distributions. The progression of the division from left to right yields first low  $r$ , high  $q$  separation efficiency pairs progressing through to high  $r$ , low  $q$  efficiencies. For each material system, the lower graph shows the fraction of both materials captured in each individual division. In the case of the electrostatic processes, this is literally the fraction of each material captured in each output bin. In the case of the magnetic roller process, which uses a divider, this graph represents the change in material fraction captured between each splitter location. These graphs physically convey the distribution of materials in the output stream, in a non-dimensional way.



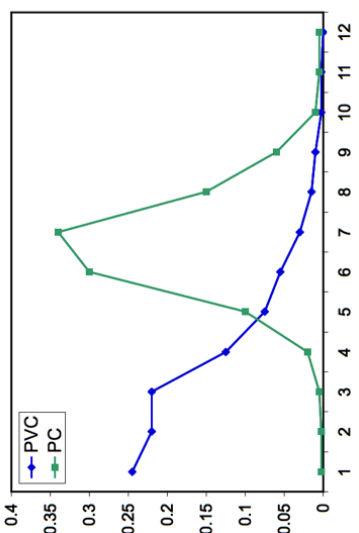
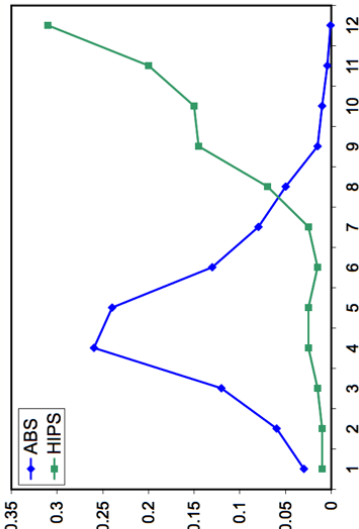
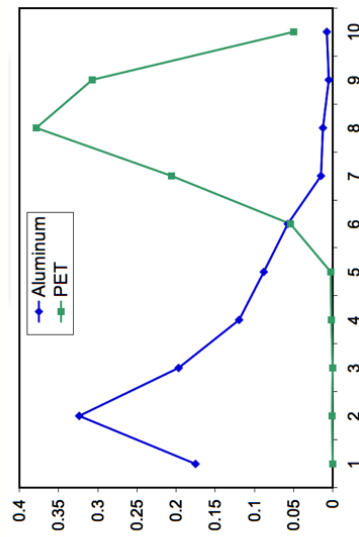
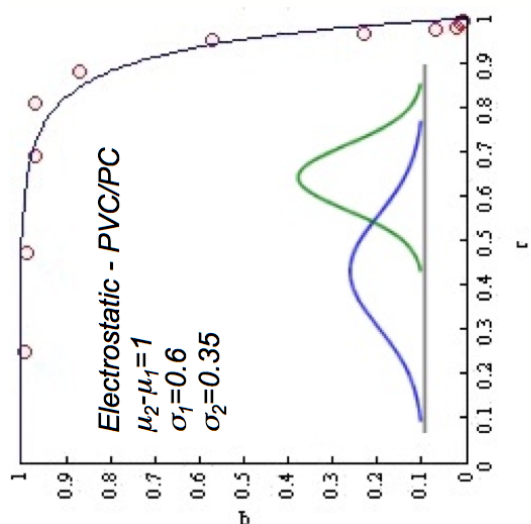
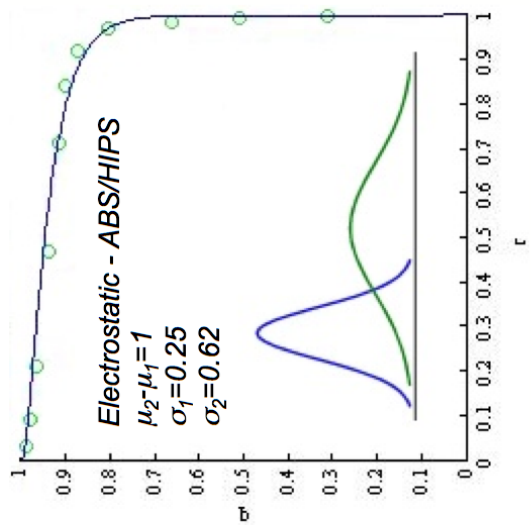
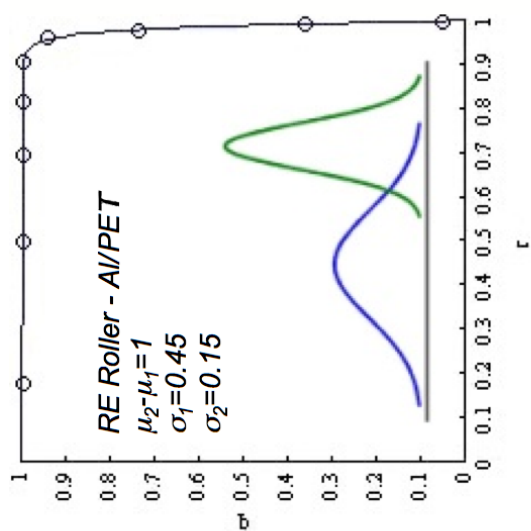

Figure 5-11: Separation efficiencies under varying separation processes for three separation processes, the electrostatic separation of PVC and PC, the electrostatic separation of ABS and HIPS, and the magnetic roller separation of PET and aluminum flake [70].

The first set of graphs in Figure 5-11 shows the separation efficiency progression for an electrostatic separation of polyvinyl chloride (PVC) and polycarbonates (PC) plastic with each point representing a different division of the process output. Here,  $r$  is the separation efficiency of PVC, and  $q$  is the separation efficiency of PC for this process. In the case of this separation process, the distribution of the target material, PVC, has a larger standard deviation than that of the non-target material, PC. This creates an asymmetric separation efficiency curve, leaning toward the non-target separation efficiencies. That is, the separator is more effective at the end of its performance spectrum when it is rejecting non-target materials at a high level than when it is capturing target materials at a high level. The electrostatic separation of acrylonitrile butadiene styrene (ABS) and high impact polystyrene (HIPS) plastics, shown in the second set of graphs in Figure 5-11, shows a similar situation, with a narrow distribution of ABS and a wider distribution of HIPS. The third set of graphs illustrates the rare-earth magnetic roller separation of aluminum and PET plastic. The distributions of these two materials are much narrower, based on standard deviation, than the distributions of the plastics in the other two processes, resulting in a tighter separation curve.

The variation in separation process performance for the processes shown in Figure 5-11 is a controlled variation that can be used by system operators to alter the performance of those processes. Variations in process performance can thus be an advantage or a disadvantage to system operators. Binary and multi-material separation system modeling can be used to capture the changes in system performance due to individual process performance variation. The utility of this ability to tailor the performance using operator-controlled parameters such as separation point will be demonstrated in an example in Section 6.1.

More typically, variation in process performance can be detrimental to overall system operations. Recycling system developers must test all individual components with typical waste samples in order to assess real separation efficiencies, while systems installed in the field must be tuned to perform their best under varying material input compositions and condition. Process performance variation is an important element

to consider in the design of separation systems.

## 5.2 Metrics for Multi-Material Systems

When measuring the performance of real material separation systems, a wide variety of data can be measured, collected, and analyzed. Metrics that combine this data are essential for conveying the essence of an analysis and creating a comparison to other systems. A performance metric combines multiple performance data into a number or set of numbers that can reflect the overall performance of the system or its performance relative to other, similar systems. Metrics can reflect different types of performance or different performance goals, and thus, multiple metrics can be applied to the same system or system model. In the case of the example metrics discussed in Chapters 3 and 4, the metrics focused on descriptions of material performance, but other metrics might describe economic performance, environmental performance, or other system considerations. This section describes some typical metrics, but many other applicable metrics exist or can be created.

### 5.2.1 Material Performance Metrics

As mentioned previously, metrics used in Chapters 3 and 4 described the material performance of binary material separation systems and multi-material separation systems, respectively. In the case of binary separation systems, the metrics used to measure system performance are recovery and grade, as defined in Equations 3.9 and 3.10. These metrics, based in mineral processing, focus on the target material stream. Any two systems processing the same binary material mixture can be compared using these metrics. One advantage of these metrics is that they can be calculated using just material performance data, and can simplify the the performance of systems with very complicated configurations to two values. A disadvantage of these metrics is that they are focused on one material and one output stream. This is suitable for separation systems that focus on one material, such as metals mining, but may be less applicable to systems where multiple materials are of concern.

The metrics used in Chapter 4 for comparing multi-material separation systems were the sum of output stream recovery and the sum of output stream grade. With a set of  $N$  materials and the  $N$  system outputs collecting these materials, the metrics are essentially defined as

$$Sum_R = \sum_{a \in N} R_{M_{out}^a}$$

$$Sum_G = \sum_{a \in N} G_{M_{out}^a}$$

These metrics, while suitable for the theoretical problems described in the chapter, may not be suitable for realistic systems. Many systems process more materials than they have system outputs. In some cases, these materials can be grouped into desired outputs, creating combined recovery and grade. The relative values of these materials and their mass fractions in the input streams could be taken as weighting factors in creating more relevant material performance metrics.

Other material performance based metrics have been used in literature, for a variety of system types. Material based metrics can also reflect the ability of separation systems to process incoming material to usefully capture results. Overall product recycling rate as described in [162] is intended to give a measure of how much input material is captured in useful material output streams, rather than the quality of those output streams. Stream quality and residual contamination from recycling and secondary processing can be a major concern for recyclers [94, 55]. Many studies trace the accumulation of trace elements in secondary metals production, particularly steel and aluminum [35, 72]. Metrics such as contamination ratio and recycling ratio reflect the average composition of contaminants in a scrap material and the dilution of that scrap with virgin material [81].

The mass flow rates of separation systems can be interpreted into a wide variety of metrics. Those used in this thesis, recovery and grade as well as sum of recovery and sum of grade, are relatively simple to compute and calculate, but reflect a simplified concept of material performance. Other material performance metrics, such

as contamination ratio, can consider material performance in a broader context.

### 5.2.2 Economic Metrics

For most separation systems, like most manufacturing systems, economic factors are an important concern. Many recycling systems are built as for-profit enterprises. In some cases subsidies are used to promote recycling, but improvements in operations and technology can lead to profitability, as in the case of plastics recycling in Europe [74]. Metrics evaluating the economic performance of separation systems are necessary for evaluating the ability of these systems to operate cost-effectively.

Economic metrics have been widely applied to separation systems, in particular recycling and end-of-life systems. Some models focus on the tradeoffs of recycling against other end-of-life options at a higher system level. These models typically consider separation processing as a fixed per unit mass cost, and compare the profitability of material separation and recovery to other end of life options such as reuse or landfilling [33, 60, 61]. Li et. al investigated the effects of sorting or not sorting aluminum alloys for recycling on profitability under sorting cost and performance variation using a similar simplified system model [92].

Other models take a more detailed approach, looking at profitability on a facility-level scale. Typically, these models assess system profitability by balancing material stream revenues against processing costs and other costs, including capital costs and financing concerns. The metrics commonly constructed from these models include net cash flow, benefit/cost ratio, and payback period, depending on the purpose of the analysis. Examples of these economic models and metrics can be found in many separation fields. Studies from mineral processing often include detailed separation cost analysis as part of overall mining operation profitability studies [52]. Studies focusing on recycling separation facilities can investigate the effects of separation system configuration on profitability. Van Schaik et al. used an economic metric [161] that balances individual output material stream values against the processing costs associated with each material flow in unit operations to determine the probable recycling rates of materials within an end-of-life vehicle recycling scenario.

Examples in Chapter 6 will discuss the construction of the metrics for the individual cases in detail. The following sections discuss aspects typically used in more detailed cost models, the valuing of material outputs and separation equipment-based cost evaluations, on a material flow rate basis. Other economic concerns that can also be evaluated based on material flow rates include input material tipping fees or purchase costs and disposal penalties on system outputs.

## **Valuing Materials**

The goal of many separation systems is to increase the sale value of input materials by providing more purified output streams. In an idealized case, material outputs of separation systems would be pure, and thus salable at prices comparable to virgin materials. Real separations rarely produce perfectly pure materials, and thus recycled scrap prices are lower than those for virgin materials. Establishing a relationship between price and purity is critical for evaluating the output value of separated material streams.

Scrap materials are a commodity, and as such their value is market based. While in theory purifying scrap materials should increase their value, in many cases, scrap materials are graded into specified material fractions for sale. These standards are set by national and international recycling organizations including Duals System Deutschland in Europe and Institute of Scrap Recycling Industries in the U.S. [37, 79]. Rather than use a direct relationship between price and purity, spot prices are given for these defined fractions, that specify minimum material purities. This would support a stepped price-purity relationship, where materials in given purity ranges all have the same price. A simplified version, used in many recycling separation system case studies, assumes that material that reaches a certain purity point can be valued at a fixed value. In some cases, it is assumed that certain material outputs of a separation system reach a salable purity and are assigned a fixed price per tonne. [54, 7, 8, 9, 10, 11]

However, the large number of scrap grades and fractions provides a dense selection of purity points. Over 40 grades of aluminum scrap, for example, are specified in

the U.S. [79]. Additionally, scrap price and purity may be specified by buyers and sellers in contracts outside of these specifications. This may suggest the possibility of applying a continuous price-purity curve for scrap materials. Figure 5-12 gives price-purity points for several materials. The price of the material is normalized against the virgin primary production price.

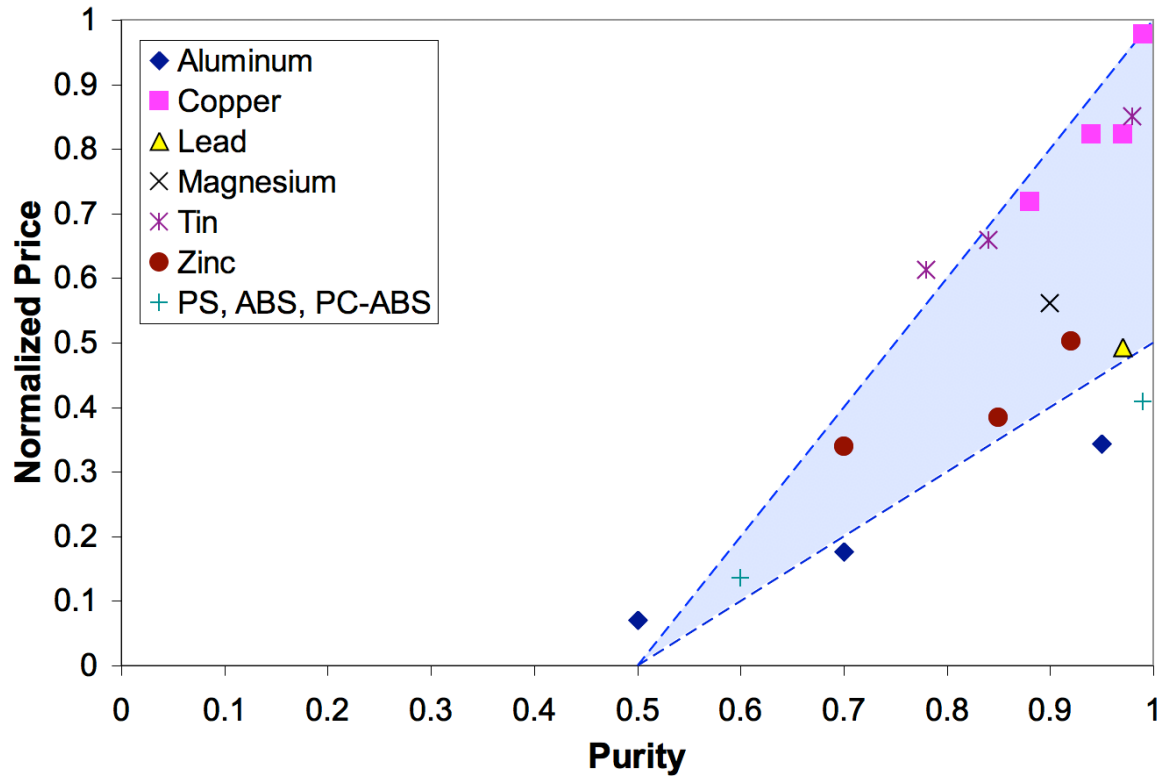

Figure 5-12: Normalized price purity curve for secondary materials production [132, 133, 134, 159, 135, 136, 137, 138, 139, 160, 140, 141, 142, 143, 144, 145, 146].

The shaded area in Figure 5-12 covers many of the price-purity points. This area begins at a named material concentration of 0.5, and progresses at its limits to equal to and 50% of virgin material price. The shape of this area suggests that the relationship between price and purity can be described with a linear equation. While in many cases, there is no given spot price for 100% pure recycled material, estimating that price with a linear fit of existing price-purity points provides a basis to create a linear price purity metric, as given in Equation 5.1.

$$p = \begin{cases} 0 & \text{for } c \leq 0.5 \\ p_{pure}(2c - 1) & \text{for } c > 0.5 \end{cases} \quad (5.1)$$

Where  $p$  is the sale price per unit mass of the mixed material output,  $c$  is the concentration or purity of that output, and  $p_{pure}$  is the theoretical “pure price” of the recycled material, estimated from that linear fit and separate from the virgin spot price. This model will be used in some of the case studies presented in Chapter 6.

Another concern for economic metrics is that material scrap prices can fluctuate greatly from month to month, usually in concert with primary material production prices. As aluminum prices fluctuated in a three-fold range between 1980 and 2005, material recycling rates followed similar upswings and downswing [57]. Similarly, increasing global demand caused four-fold price fluctuations in the purchase price of steel scrap between 2002 and 2004 [28].

Material price calculations are sensitive to a variety of factors, in particular the relationship constructed between price and purity. Scrap prices are sensitive to market fluctuations, and thus the value of the material outputs of a separation stream may vary greatly during its operational lifetime, complicating economic analysis.

## Evaluating Costs

While the sources of revenue associated with a separation system are identified through the system material outputs, the costs associated with a separation system are largely based on the ownership and operation of separation equipment and facilities. As these costs are dependent on the equipment and facility, listing all the potential sources of cost is not possible without a specific description of the facility. Table 5.1 provides a list of possible costs, an indicator that notes if a cost source would be based on ownership, a description of those costs.

The “Ownership” indicator suggests cost sources that would be present once a facility is built, no matter its production status. This is not meant to suggest that



Table 5.1: Potential cost sources of a separation system facility.

	Ownership	Description
Equipment	X	Capital cost of owning separation equipment.
Installation	X	Installation and support equipment.
Facility Space	X	Ownership or leasing of workspace.
Financing	X	Financing costs for equipment and workspace.
Taxes	X	Property and business taxes. Sales and waste taxes operationally based.
Labor		Equipment operator wages and benefits.
Utilities		Electricity, water, and other utilities.
Shipping		Packaging, hauling, and other shipping costs.
Waste Disposal		Disposal fees for non-salable materials.

the costs of these portions are not influenced by the intended operational state of the facility; the selection of appropriate equipment and facilities will be guided by the mass flow rates evaluated during the planning stages of the separation system.

The actual cost of each of these cost components varies greatly between recycling facilities. For example, production scale separation equipment can vary in cost from less than ten thousand dollars for a small scale magnetic drum separator to over five hundred thousand dollars for a large sense-and-sort type process.

Table 5.1 is not a comprehensive list of all the possible costs, and does not present methods for assigning these costs for the sake of constructing an economic metric. The details of the separation system and the chosen economic metric will determine the method of assigning costs. In general, three methods of cost assignment can be used when associating costs to a mass flow based model, as described in this thesis. Costs can be assigned as fixed capital costs, hourly operational costs, and costs per unit mass processed. Examples of this type of cost assignment will be discussed in individual case studies in Chapter 6.

### 5.2.3 Energy and Environmental Performance

Energy and other environmental performance measures are a concern for all manufacturing systems. In particular, material recycling, as discussed in Chapter 1 is often suggested to be an environmentally friendly activity because of the potential energy

savings involved with using secondary production from scrap. To realize this potential, additional energy outlay for collection, separation, and material processing have to be invested. The potential energy return on investment is an important component of the environmental performance of separation systems for material recycling.

In general, the processes involved material recycling systems are relatively less energy intensive than typical manufacturing and material production processes. Figure 5-13 shows the energy intensity and processing rates for separation and comminution processes as compared to traditional manufacturing processes. Comminution processes (shredding and other size reduction processes) are frequently included in the overall design of material recycling systems.

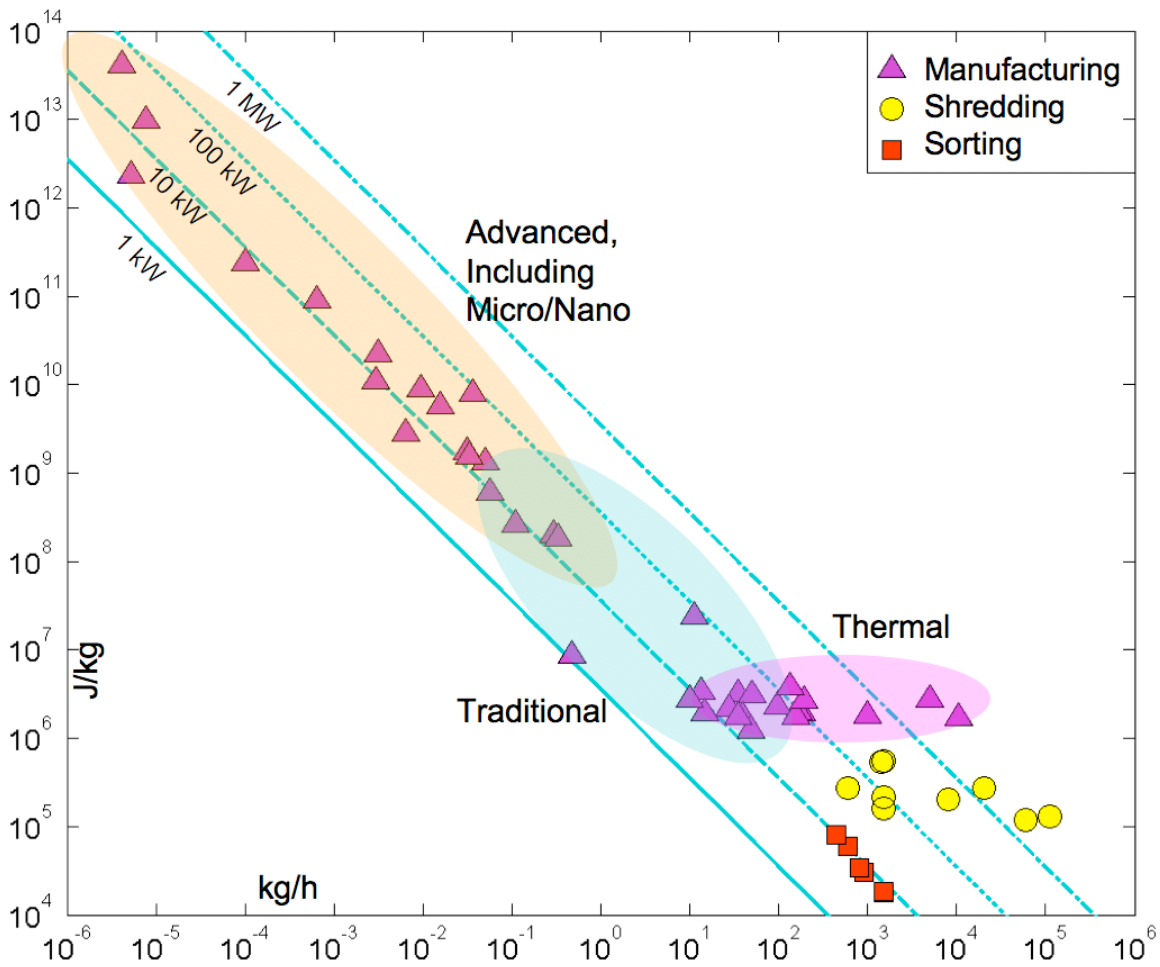

Figure 5-13: Energy intensity and mass flow rate for a variety of manufacturing and recycling processes (adapted from [70]. [66, 98, 97, 126]).

The separation processes shown in the figure, which are all industrial-sized processes, have energy intensities between roughly 1 and 10 kJ/kg, while the comminution processes consume between roughly 10 and 100 kJ/kg. Compared to other manufacturing processes, including thermal processes such as melters for casting, traditional machining such as turning and grinding, and advanced processes such as chemical vapor deposition, sputtering, and oxidation, these recycling processes are much lower energy intensity. The embodied energy of materials that are frequently recycled, such as paper, metals, and plastics, are between 10 and several hundred MJ/kg. Thus, a material recycling system built of several separation and comminution processes and their support equipment has the potential to save energy by recycling material. In fact, studies on the recycling of household waste electrical and electronic equipment including washing machines, televisions, personal computers, and refrigerators find that the recycling process on its own saves energy by returning usable materials [12, 90, 46].

Constructing a metric for the energy saved by recycling requires calculating the energy value of materials saved by recovery, energy costs from transportation, processing and landfilling, and other larger material production system energy issues. The focus of this thesis is separation system analysis; rather than construct a comprehensive metric that investigates all aspects of material recycling, as created in [12, 90, 46], the focus of energy analysis here will instead be on creating an operating energy total for the system of separation stages. With binary and multi-material separation system modeling as described in previous chapters, the mass flow rates of all materials at each process is calculated. The total mass flow rate at each stage can be combined with separation process energy intensities to calculate an estimate of the energy consumption per unit time for the separation system. Table 5.2 gives separation intensities per unit mass for a selection of comminution and separation processes.

The energy intensity of individual processes can vary based on exact type of equipment, manufacturer, operational settings, and input material mixture quality and flow rate. An accurate measurement of plant energy use would be better calculated using

Table 5.2: Typical energy intensities for some common material separation system processes (adapted from [46]).

Process Type	Technology	Energy Intensity (MJ/kg)	Sources
Shredding	Cross-flow shredder	0.39	[93]
	Hammermill	0.12 - 0.22	[98, 97, 126]
	Bladed Chopper	0.27 - 0.55	[97]
Ferrous	Permanent Magnet	0.09	[93]
Non-Ferrous	Eddy-Current	0.02 - 0.08	[97, 93]
Plastics	Sieving	0.06 - 0.14	[45, 97]
	Triboelectric & Air Table	2.52	[45]

specific electricity requirements given by equipment manufacturers, through individual equipment electric performance measurement, or at a high level through plant electric usage meters or bills. In general, estimates of the energy performance of a material separation system must take into account system specifics.

Environmental performance can be approached in a similar way. Rather than assess the whole system impact including the environmental impact of the recycled materials, offset production, transportation, and other external impacts, a more focused assessment can be taken for the environmental performance of the separation facility itself. This assessment should include all utility and support inputs. For many separation processes, the primary input is simply electricity, but many processes and facilities use water, cleaning agents, separation media, and consumable machine parts, among others. The typical impact per unit of material processed or operational time can be measured through these additional inputs, assigning energy and environmental impacts including greenhouse gas and pollutants to each separation process and to the facility as a whole.

# Chapter 6

## Case Studies

The modeling technique described in this work utilizes programatically solvable linear equations. In conjunction with enumerative techniques, this method can be used to investigate optimal separation system configurations by comparing separation stage configurations and operating parameter options. In many cases, the options for configuration can be exhaustively searched, investigating cases that would likely be ignored when hand-selection is required in the course of modeling.

This section presents case studies where this technique is used to identify potential configurations of material separation systems. These case studies are intended to demonstrate both the techniques used to apply this model, and the advantages gained by using this model for analyzing material separation system performance.

## 6.1 Binary Separation of PET and Aluminum Flake

Polyethylene terephthalate (PET) plastic is commonly used in plastic beverage bottles. As of 2009, PET beverage bottles were collected for recycling at a rate of 28% [108]. Indeed, PET plastic is one of the most commonly recycled plastics, with about 20-30% of the current supply coming from recycled sources [51, 5]. One potential application for the recycled plastic is in new beverage containers. Typically, virgin and recycled materials are mixed together in recycled material production. Coca-Cola Enterprises reports that in 2010 the recycled content in their bottles increased to 17.5% in 2010, up from 10% in 2009 [26]. Studies have suggested that even higher percentages could be successfully incorporated into future bottle production [6].

Recycled PET must attain a high purity for inclusion in beverage bottles. Plastic incompatibilities can compromise the integrity of the pressurized bottles. A typical PET beverage bottle is formed through stretch blow molding [91], in which contaminating metal particles are trapped in upstream feed lines and dies, preventing them from incorporating into the final bottles, but clogging the flow path of the plastic. Consequently, PET beverage bottles undergo an extensive purification process when they are recycled, usually starting with bulk separation from other curbside recyclables, followed by a mix of shredding, washing, and additional separation stages [100]. A wide variety of separation processes are used in these purification systems, including eddy current separation and magnetic roller separation. As described in Section 5.1.3, magnetic roller separation is typically used during the final refining of PET shreds. This case study describes the configuration of separation systems using this magnetic roller process for removing aluminum contaminants before the final metal detector-based cleaning of the PET, as first profiled in [166].

### 6.1.1 System Profile

Shredded PET plastic intended for use in beverage containers must have very little non-plastic contamination. In many cases, the final contaminant to be removed from PET plastic is aluminum contamination from the few beverage cans that escaped

detection prior to shredding. With particles sized well below a half an inch, eddy current separation is no longer a viable option for isolating these aluminum particles, but the still high contamination level is unsuitable for processing with through flow metal detection units, which divert the product stream to waste when an aluminum particle is detected, creating high waste levels. Rare-earth magnetic roller separation, as first described in Section 5.1.3, fills the gap in processing, able to handle small particles and higher contamination levels. Figure 5-4 depicts a magnetic roller separator processing a PET and aluminum beverage container shred stream. Depending on input material concentrations and output material purity requirements, multiple stages of magnetic roller separation may be needed.

### Material Inputs

As described, the material prepared for magnetic roller separation is a washed, shredded material stream, consisting of primarily PET plastic, with traces of plastics and aluminum contamination. This material is shredded to below half an inch. Figure 6-1 shows typical particle sizes for this fine shred.



Figure 6-1: Typical PET material as prepared for magnetic roller separation, with scale in centimeters (from [75]).

The contamination level of the input shreds varies based on upstream material sources and sorting practices, but a typical aluminum contamination level is between 500 and 2500 parts per million by weight, and consists of aluminum can shreds roughly the same size as the plastic shreds. For this case study, we will assume a high input

concentration, of 2500 parts per million by weight of aluminum.

## Performance Requirements

The material processed by magnetic roller separation is then fed into flow diverters that use metal detection to identify aluminum contamination in the plastic stream. Because the detectors use flow diversion to eject contaminant particles, a large quantity of plastic is ejected along with any contaminants. The target contamination level for material entering the metal detection units after magnetic roller separation is dependent on the flow capacity of the metal detection units and economic concerns, but in general is expected to tolerate a maximum aluminum contamination of between 25 and 50 parts per million by weight. For this case study, we will assume a strict output contamination tolerance, of 25 parts per million by weight of aluminum.

## Individual Process Performance

In this case, the rare-earth magnetic roller process is separating PET and aluminum beverage container shreds. Separation efficiencies for this process while separating these materials was described in Section 5.1.3. The separation efficiencies are repeated here in Figure 6-2 and Table 6.1.

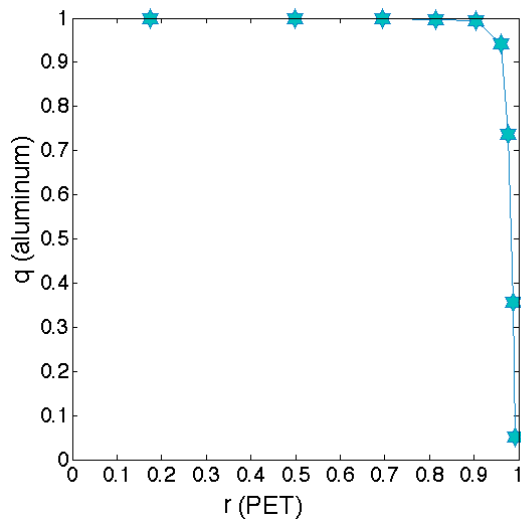

Figure 6-2: Separation efficiency of the rare-earth magnetic roller process.

$r$ (PET plastic)	$q$ (aluminum)
0.993	0.050
0.988	0.358
0.976	0.736
0.960	0.942
0.903	0.995
0.815	0.998
0.695	0.998
0.499	0.999
0.175	1.000

Table 6.1: Separation efficiency of the rare earth magnetic roller process.



To use these separation efficiencies, the assumption is made that operating conditions in the separation system being modeled are similar to those under which the efficiency data in Table 6.1 were measured. The experimental trials used to generate this data used typical beverage container shred, at low aluminum concentrations, at feed rates typical for magnetic roller separation. In addition, Section 5.1.3 discussed that under typical operating conditions, the magnetic roller process separation efficiencies are independent of concentration. Thus, these separation efficiency data may be applicable to a typical beverage container shred purification system employing magnetic roller processes.

### 6.1.2 Investigation of Configuration Options

The selection of an appropriate separation system configuration of magnetic roller processes and appropriate operating points for those processes can be investigated using the binary material separation system modeling technique as presented in Chapter 3. First, the performance of a separation system of a single processing stage is considered. In this case, only the performance of the magnetic roller process can be varied. Table 6.2 gives the resulting aluminum contamination and PET recovery for each point of operation for that single step system.

Table 6.2: Aluminum contamination and PET recovery using a single magnetic roller stage operating at different separation efficiencies.

$r$ (PET plastic)	$q$ (aluminum)	Aluminum Contamination (ppm weight)	PET Recovery
0.993	0.050	2,392	99.3%
0.988	0.358	1,628	98.8%
0.976	0.736	678	97.6%
0.960	0.942	152	96.0%
0.903	0.995	15	90.3%
0.815	0.998	7	81.5%
0.695	0.998	4	69.5%
0.499	0.999	4	49.9%
0.175	1.000	1	17.5%

Reducing the level of aluminum contamination to below 25 parts per million by weight requires a 10% loss of PET plastic. Using an additional separation stage can increase the recovery of the plastic. The potential separation success for a system with two separation stages is analyzed by taking the envelope of optimal separation systems of two steps, three of which are depicted in 3-8, and for each of those configurations iterating through all the possible pairs of operating points for those two stages. Model code developed in MATLAB is used here to enumerate these potential configurations and evaluate the material performance of each of those configurations, for immediate automatic comparison, or for later user inspection. The two stage separation magnetic roller system that achieves the highest recovery while meeting the purity requirements is shown in Figure 6-3.

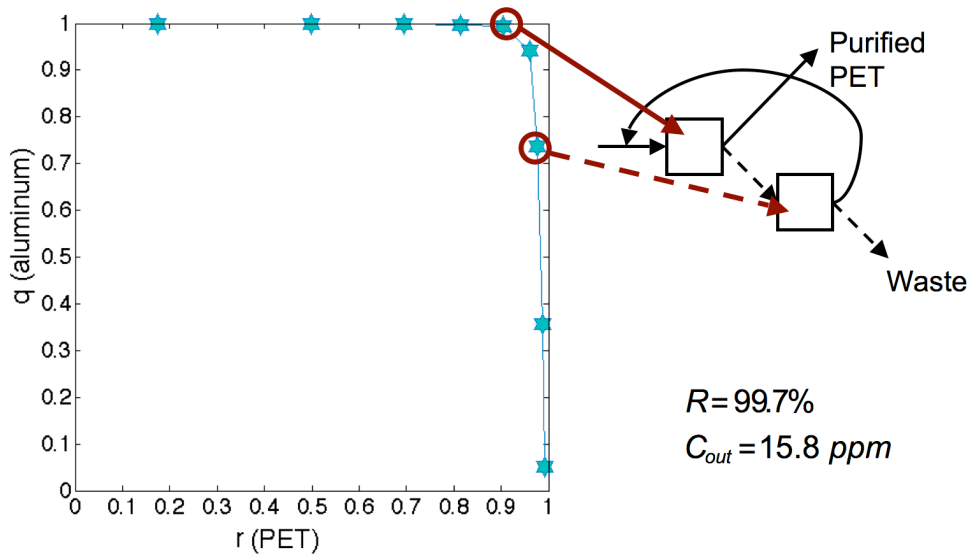

Figure 6-3: Optimal selection of a two separation stage configuration and operating parameters for magnetic roller processing of PET and aluminum beverage container shreds.

The separation efficiency operating points for the configuration with the best performance as defined by recovery at a given contamination level are circled on the accompanying graph. The form for that system takes the same for as that in Figure 3-8b. The initial separation step has a very high aluminum rejection efficiency ( $q = 0.995$ ), and a moderate PET recovery ( $r = 0.903$ ), directing a very pure PET

stream to the target output. The secondary output is directed to another magnetic roller process, operating at a relatively low aluminum rejection rate ( $q = 0.736$ ), but a high PET recovery ( $r = 0.976$ ), redirecting most of the PET plastic entering the process to the purifying first step, saving it from the non-target output.

This case study shows that the binary material separation modeling techniques presented in Chapter 3 can be used to select operating parameters among an array of choices that would be daunting to enumerate by hand. Simplifying the selection process to reduce the amount of initial choices, by picking a configuration and varying separation efficiencies or by picking fixed separation efficiencies and adjusting the configurations, could easily leave out the optimal choice identified in this section. By creating a model that can be configured iteratively and solved algorithmically, binary material separation modeling assures that the best configuration and operating points are found.

## 6.2 Site B: A Plastic Container Separation Facility

Plastics separation is one of the most challenging areas of recycling. Many species of plastic are incompatible with each other, for example, polyvinyl chloride (PVC) and polyethylene terephthalate (PET) are difficult to separate because of their similar densities and mutually incompatible because of their different processing temperatures [128]. The best practices separation of mixed plastics requires the use of modern separation technologies. Sense and sort technologies, which use sensors, such as metal detectors, x-ray detectors, and optical technologies, to detect desired particles, which are then captured using physical mechanisms, such as deflecting flaps or pneumatic jets. One sense and sort process that is commonly used with plastics is near infrared (NIR) sorters, in which NIR spectroscopy is used to identify plastics [111, 88, 127]. These NIR machines can be programmed to target different species of plastics based on their spectrographic profiles, and thus offer flexibility in target material.

The following case study investigates the performance of a plastic container separation facility, profiled by Axion Consulting in the report "Good practice of Near Infrared sorting of plastic packaging" [54]. This facility, known as Site B, takes in a mixed plastics container fraction, and uses NIR separation to create several single-species output streams.

### 6.2.1 Site B Facility Description

Site B processes a mixed plastics container fraction, that is composed primarily of small to medium sized empty rigid plastic containers. The incoming material is coarsely shredded, to 20 centimeters maximum size. Magnetic separation is used to remove metal contaminants, and then a windsifter is used to remove films and other light materials, such as labels, paper, and thin plastic films. The material is then fed into the NIR sorter line. The NIR sorted materials are stored in bunkers. A baler prepares the material from the bunkers for shipping to plastics refiners. The flowsheet for Site B is shown in Figure 6-4.

The NIR processors target, in order; HDPE, clear PET, coloured PET, PP, and

HDPE. The final NIR process is reprogrammed seasonally to take advantage of the changing material composition of the input fraction. Plastic containers collected during the summer are expected to have a higher frequency of PET; NIR machine 7 can be programmed to target PET during those periods.

The plant processes approximately 8-10 tonnes per hour. The pre-NIR separations remove only a small fraction of the input materials leaving the NIR separation line to process roughly 8-10 tonnes per hour as well.

Very little handpicking is used at Site B. Handpicking is typically used in plastics recycling facilities, but there is only used to clean the clear PET fraction prior to baling. Approximately 0.18%, a very small fraction of the clear PET stream, is removed at this stage. The lack of handsorting is due to the high quality of the feedstock and the tuning of the site's NIR sorting machines. The plastics stream received by the facility exceeds the purity requirements of the fraction. The facility operators have tuned the NIR sorting equipment to their expected feedstock, reducing the need for handpicking.

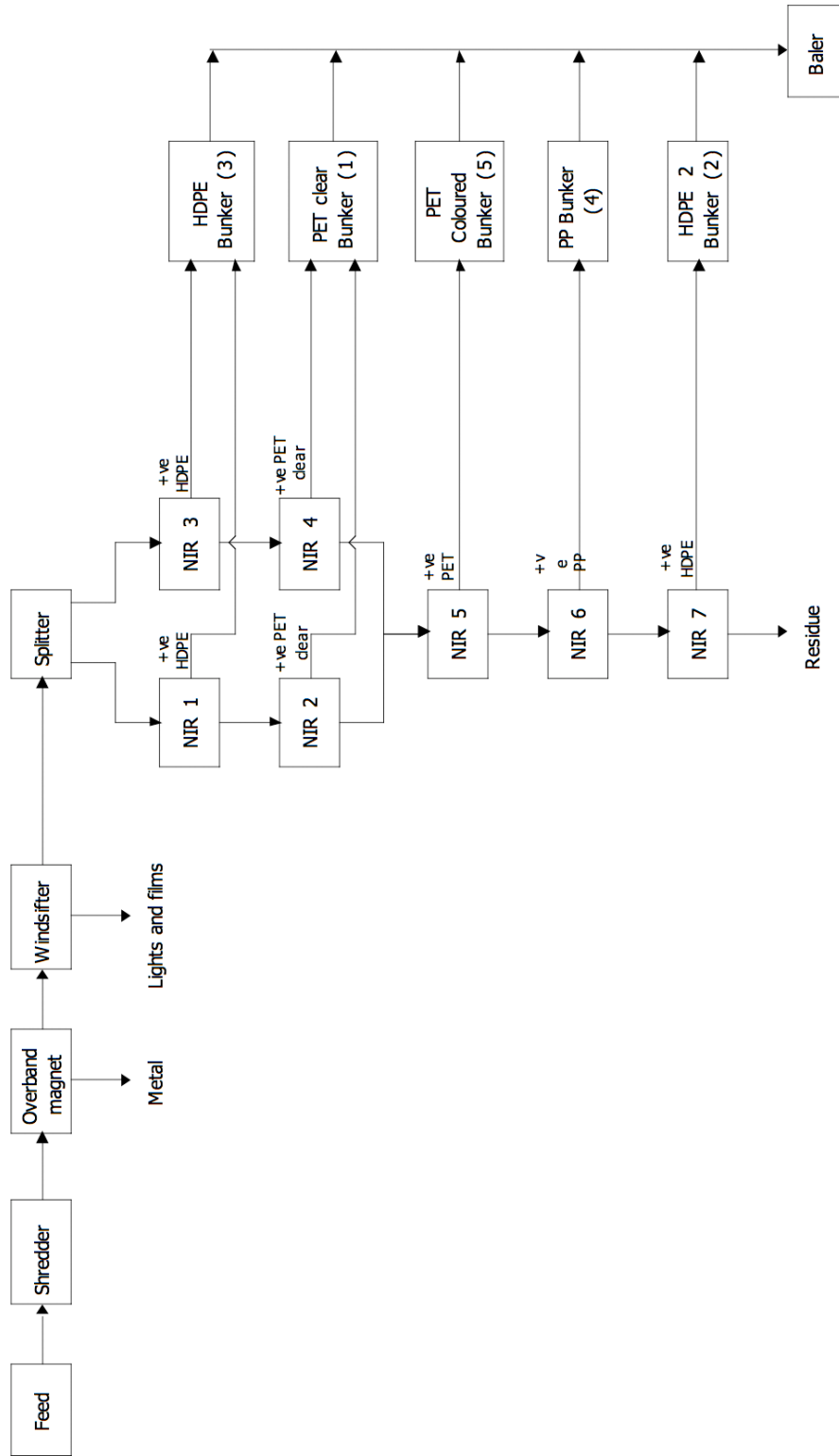

Figure 6-4: Site B process flowsheet (from [54]).

## 6.2.2 Modeling Current Facility

The multi-material material separation system modeling techniques as described in Chapter 4 can be applied to Site B. These techniques are used here to capture the same performance as measured by Axion Consulting in their experimental trials. By modeling the observed system, we can infer aspects of performance that were not measured as part of the trials, providing a more complete picture of the separation system.

The multi-material material separation system modeling techniques from Chapter 4 require several inputs to calculate the material performance of the system, including the composition of the material input stream, the configuration of the separation system, and the separation performance of the individual processes.

### Material Inputs

Site B processes a mixture of plastic containers. The specific fraction that they receive at the facility is DSD Fraction No. 320, a mixed plastic bottle fraction as specified by Deutsche Gesellschaft für Kreislaufwirtschaft und Rohstoffe mbH [38]. The specification, as given in Table 6.3, gives minimum and maximum levels of stream components by weight.

The DSD Fraction No. 320 specification as given in Table 6.3 does not specify the mixture of plastics species that will be included in the input stream. The exact composition varies based on the original collection source, preprocessing technique, and other factors. The material received by Site B is very low in impurities. The site does not frequently conduct input compositional analysis. Figure 6-5 shows the composition considered typical at Site B, based on a compositional analysis from the winter of 2009.

The compositional analysis shows a high HDPE content, over 50%, which is expected for winter composition. The next largest constituent is clear PET, at roughly 30%, followed by polypropylene (PP) and coloured PET. Residue (including other plastics) are expected to make up about 3% of the mixture.

Table 6.3: Composition requirements for DSD Fraction No. 320 [38].

DSD Fraction No. 320: Mixed Plastic Bottles		
Material	Requirement (by mass)	Description
Mixed plastic bottles	>94%	Used, completely emptied, rigid, system-compatible packaging made of plastic, volume $\leq 5$ litres, e.g. detergent and household cleaner bottles, incl. packaging parts such as caps, labels etc.
Total impurities	<6%	Examples of impurities include glass, paper, cardboard, composite paper materials, aluminized plastics, rubber, stones, wood, textiles, diapers, and compostable waste such as food and garde waste.
Metal items	<0.5%	
Other plastic articles	<3%	
Other residual materials	<3%	

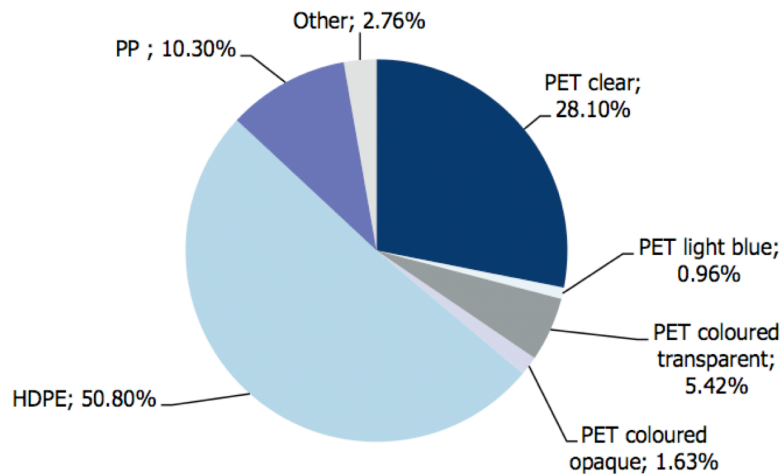

Figure 6-5: Typical DSD Fraction No. 320 plastics composition at Site B (from [54]).



## System Configuration

The separation system flowsheet shown in Figure 6-4 includes several upstream processes that are not part of the central NIR plastics separation line. The shredder, overband magnetic separator, and windsifter all work to prepare the plastics for the NIR separation line, reducing the particle size and removing the relatively small portion of the input stream that is not plastic bottles and containers. The plastics line can be modeled as a stand-alone system, fed by the pre-processing line. Modeling this system separately results in the configuration shown in Figure 6-6. The NIR processes that run in parallel, NIR machines 1 and 3, and NIR machines 2 and 4, can be combined into a single separation stage, as their performance is intended to be identical, and measurements for the two processes are combined.

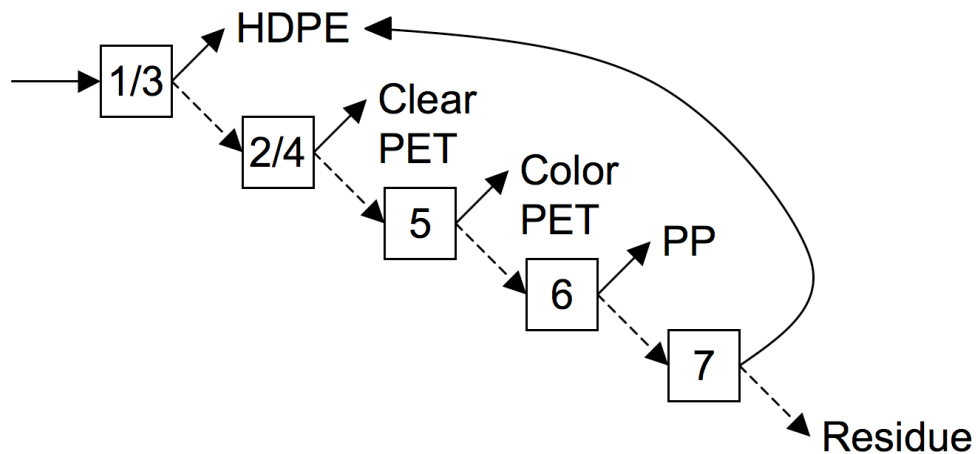

Figure 6-6: Site B plastics separation system configuration.

The two HDPE bunkers are combined in this configuration, as the two bunkers are mixed together for baling. The simplified flowsheet includes five separation stages and five system material outputs.

## Process Performance

Individual process performance was measured by Axion Consulting during experimental trials. They chose to measure the system performance in terms of target and non-target separation, giving a target separation efficiency for the plastic species

targeted by each NIR separator. The non-target separation efficiency combines the performance for all the other plastics and residue in the material streams. The separation efficiencies are measured using samples from the two material output streams of each process. These measured separation efficiencies are given in Table 6.4.

Table 6.4: NIR process performance as given by Axion [54].

Input NIR machine	Target Material	Target Efficiency ( $r$ )	Non-Target Efficiency ( $q$ )
NIR 1 and 3	HDPE	90%	95%
NIR 2 and 4	Clear PET	55%	96%
NIR 5	Coloured PET	53%	97%
NIR 6	PP	82%	99%
NIR 7	HDPE	39%	99%

The separation efficiencies given in Table 6.4 are binary separation efficiencies, giving a target and non-target separation efficiency. However, a multi-material separation system analysis requires a material separation matrix for each process, which has individual separation efficiencies for each material, as described in Section 4.1.2. Without specific information about the material performance for each material in each process, assumptions must be made to convert binary separation efficiencies to a material separation matrix. In all cases, the performance of the target material is fully defined, but the performance of non-target materials are lumped together. Without further information on the performance of the processes or more detailed measurements of each of the output streams, the simplest assumption to make is that the non-target separation efficiency applies equally to each material, and thus the secondary separation efficiency for each non-target material is simply equal to the overall non-target separation efficiency. The exception to this case is in the performance of NIR machine 5, which targets coloured PET plastic. The target separation efficiency given in Table 6.4 is a combined efficiency for both color categories of PET, while the non-target separation efficiency combines HDPE, PP, and residue performance. Using additional information about the performance of NIR machine 5, we can estimate the individual separation efficiencies for the clear and the coloured PET. The

primary separation efficiency for the coloured PET alone is given as 69%, while the clear PET is described as having an even split between the primary and secondary output streams. The resulting material separation matrix is included in Table 6.5, along with the estimated material separation matrices for the other NIR separation processes.

Table 6.5: NIR process multi-material separation efficiencies.

NIR 1 and 3		
HDPE	90%	10%
Clear PET	5%	95%
Coloured PET	5%	95%
PP	5%	95%
Residue	5%	95%

NIR 6		
HDPE	1%	99%
Clear PET	1%	99%
Coloured PET	1%	99%
PP	82%	18%
Residue	1%	99%

NIR 2 and 4		
HDPE	4%	96%
Clear PET	55%	45%
Coloured PET	4%	96%
PP	4%	96%
Residue	4%	96%

NIR 7		
HDPE	39%	61%
Clear PET	1%	99%
Coloured PET	1%	99%
PP	1%	99%
Residue	1%	99%

NIR 5		
HDPE	3%	97%
Clear PET	50%	50%
Coloured PET	69%	31%
PP	3%	97%
Residue	3%	97%

### Matching Current Performance

The input material composition, system configuration, and multi-material separation efficiencies described in the preceding sections can be used to model the performance of the experimental trials. Axion's report gives the output material performance of the system when processing a single campaign of approximately 36 tonnes of input mixture. The percentage of system mass flow rate into each of the system outputs is given. The yield and purity (recovery and grade) are given for each individual plastic species collected from the output material streams of the separation system,

including HDPE, clear and colored PET, and PP. The HDPE fraction in this case is the combined outputs of NIRs 1, 3, and 7. Table 6.6 presents the mass accounting for the system outputs, while Table 6.7 gives the plastic species' purities and yields.

Table 6.6: Site B output fractions from Axion trials (adapted from [54]).

Input	Tonnes	Percentage
Input feed	36.20	100.0%
Output fractions	Tonnes	Percentage
Clear PET	8.10	22.4%
Coloured PET	4.78	13.2%
HDPE (1)	11.30	31.2%
HDPE (2)	0.53	1.5%
PP	2.50	6.9%
Low grade plastic (Residue)	8.23	22.7%
Metal	0.28	0.8%
Lights and films	0.05	0.1%
Handpicked	0.01	0.0%
Samples	0.35	1.0%
Total outputs	36.13	99.8%
Losses	0.08	0.2%

Table 6.7: Site B performance trial product purities and yields [54].

Fraction	Yield	Purity
HDPE	94%	89%
Clear PET	53%	95%
Coloured PET	60%	33% with respect to coloured PET 95% with respect to total PET
PP	76%	95%

Applying the configuration, separation efficiencies, and input material composition given in the preceding sections yields the material performance given in Table 6.8. The multi-material separation system model calculates the mass flow rate of each material at each separation stage and system material output. These flow rates are used to determine the yield (or recovery) of each material into its desired output stream, the purity of the material in that output stream, and the fraction of the total input mass that is captured in each output stream. In Table 6.8, each of these

modeled values is compared to the experimentally measured values. For the coloured PET stream, the yield is calculated for the coloured PET alone, while the purity is based on the combination of clear and coloured PET. Yield and purity are not given for the residue stream because the desired content of this residue plastics stream is not specified.

Table 6.8: Site B performance trial product purities and yields.

Material	Measured Yield	Model Yield	Measured Purity	Model Purity	Measured Mass	Model Mass
HDPE	94%	94%	89%	95%	33.4%	50.1%
Clear PET	53%	52%	95%	94%	22.9%	16.2%
Coloured PET	60%	62%	95%	95%	13.5%	11.2%
PP	76%	72%	95%	98%	7.1%	7.6%
Residue					23.2%	14.9%

While the modeled yields are relatively close, particularly in the system outputs from earlier stages, the purities and mass fractions are more divergent. Of the components used in modeling this system, the configuration is known, and the separation performance is measured, but the material input breakdown is guessed based on previous measurement. In an industry where the contents of a post-consumer collected stream can vary in each truckload, the typical plastics breakdown shown in Figure 6-5 may not provide an accurate picture of a given processing campaign.

While the material separation matrix and output material data do not provide a complete picture of the system’s performance, they can be used to estimate a more probable input material composition. MATLAB’s `lsqnonlin` non-linear function least squares optimization was used to find an original input material composition. In this problem, the input material concentration is taken as the input to be optimized. The function to be minimized here is then the difference between output material breakdown as calculated by the multi-material system model developed for Site B using a given input mixture, and the actual output material masses as measured by Axion and given in Table 6.6. This solution of this optimization problem suggests an original material composition with a lower HDPE content, and a higher PET and

residue content, as shown in Table 6.9.

Table 6.9: Input material concentration, as assumed by plant operators and as estimated from measured performance.

Material	“Typical” Composition	Estimated Composition
HDPE	50.80%	31.81%
Clear PET	29.06%	41.61%
Coloured PET	7.05%	6.27%
PP	10.30%	9.39%
Residue	2.79%	10.92%

The estimated composition given in Table 6.9 creates a much closer match in final performance than the typical concentration profiled by Site B operators in Figure 6-5, as shown in Table 6.10. While the construction of the multi-material separation matrices leaves some room for error, the estimated composition may more accurately represent the incoming material composition. Additionally, the output mass stream fractions measured in this trial are not atypical. Figure 6-7 shows the output stream mass fractions for different trial dates. The samples taken on these dates have a similar output division to that measured by Axion during their trials. This implies that the “typical” input fraction may no longer represent the DSD Fraction No. 320 material being supplied to Site B.

Table 6.10: Site B performance trial product purities and yields modeled with new input composition.

Material	Measured Yield	New Model Yield	Measured Purity	New Model Purity	Measured Mass	New Model Mass
HDPE	94%	94%	89%	89%	33.4%	33.4%
Clear PET	53%	52%	95%	95%	22.9%	22.9%
Coloured PET	60%	62%	95%	95%	13.5%	13.5%
PP	76%	72%	95%	97%	7.1%	7.0%
Residue					23.2%	23.2%

In this case, multi-material separation system modeling provides an insight into the unknown parameters of the system, suggesting an incoming material composition that yields more realistic results than the default assumed material composition.

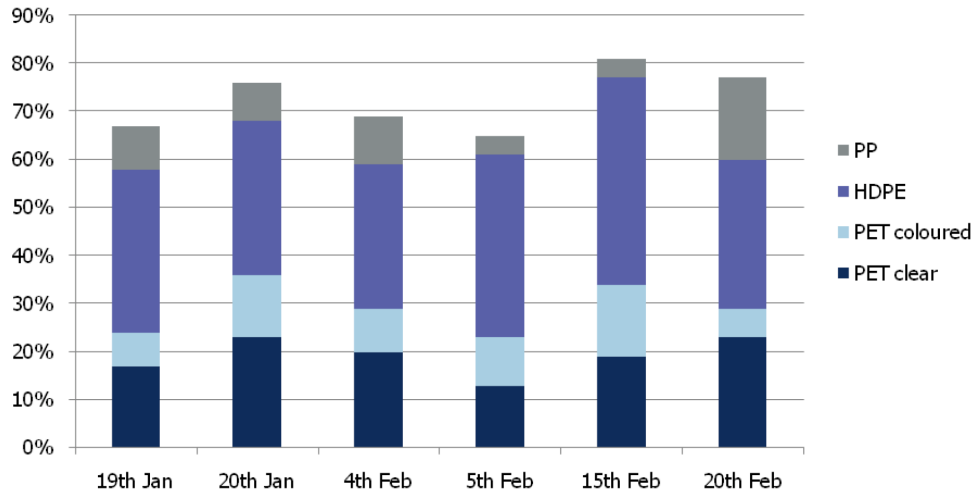

Figure 6-7: Site B production material fraction breakdown for dates in January and February 2010 (from [54]).

### 6.2.3 Investigation of Configuration Options

Site B is constructed with a fixed configuration, but the target material and performance thresholds for the NIR processes that make up the plastics processing line can be reprogrammed. In fact, the facility typically reprograms NIR machine 7, the final stage used to capture a small amount of additional material. In the case of the configuration shown in Figure 6-4, NIR 7 is used to capture HDPE, but the facility operators switch to capturing PET plastic during periods that they expect high PET content in the stream, such as the summer months, resulting in the system configuration shown in Figure 6-8. In this case study, the economic impact of the decision to target HDPE or PET with this last NIR sorter is investigated.

#### Economic Comparison Metric

To calculate the economic impact of the target material decision, an economic metric must be constructed. In this case, the operating costs incurred by the separation system will vary negligibly based on the target material choice. NIR 7 will be processing the same amount of material, the storage hopper already exist for its output, and the total amount of material collected at NIR 7 is minor compared to upstream stages in the system. The focus of this economic metric is instead the revenues gen-

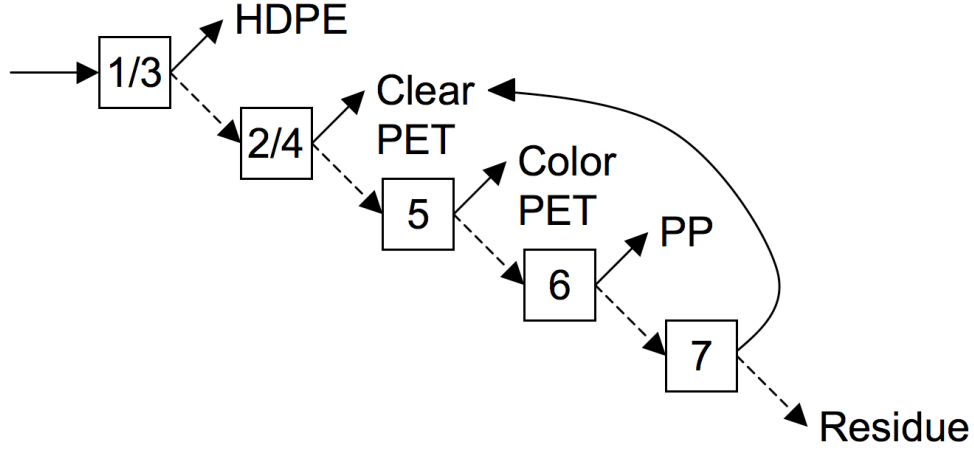

Figure 6-8: Alternative Site B plastics separation system configuration, targeting PET plastic.

erated by targeting the different materials. The revenues generated by this stage are based in the two plastic outputs of this stage, the target material stream and the residue stream. The per-tonne value of the streams and the quantity of the output stream determine the value of each stream. The quantity of the output stream will be calculated using the multi-material separation system modeling technique, while the per-tonne value of the streams is taken as a fixed value, provided by Axion. The material values are given as, for mixed HDPE, £160 per tonne, and for clear PET, £230 per tonne. These values assume that the material from either stream achieves an acceptable purity for sale, and that the value of the stream is not adjusted for purity. The value of the residue plastic is given as £30 per tonne. The total value of the output from NIR machine 7 per tonne of material input to the overall system is shown in Equation 6.1.

$$\text{Value} = \begin{cases} \pounds 230m_{NIR7,p}^{Total} + \pounds 30m_{NIR7,s}^{Total} & \text{for clear PET-targeting NIR 7} \\ \pounds 160m_{NIR7,p}^{Total} + \pounds 30m_{NIR7,s}^{Total} & \text{for HDPE-targeting NIR 7} \end{cases} \quad (6.1)$$

Where  $m_{NIR7,p}^{Total}$  is the total mass flow to the primary output of NIR machine 7 per tonne of input and  $m_{NIR7,s}^{Total}$  is the total mass flow to the secondary output of NIR



machine 7 per tonne of input. These quantities of output material must be computed using the multi-material separation system model.

### NIR Machine 7 Performance

As stated previously, the multi-material separation system model requires input material composition, the system configuration, and the multi-material separation matrix for each process in that configuration to calculate the mass flow rates in the system. Two possible system configurations have been presented, one with NIR machine 7 targeting HDPE, and one with NIR machine 7 targeting clear PET, and the variation in input material content is one of the factors under investigation, with several prospective cases in consideration. While the performance of NIR machines 1 through 6 is defined, the multi-material separation matrix of NIR machine 7 is only given in the case of HDPE targeting for that stage, shown in 6.5. The HDPE separation efficiency into the primary output stream of NIR machine 7 while targeting HDPE is much lower than the performance of the other processes targeting HDPE, NIR machines 1 and 3. This lowered performance is in some part a choice of the system operators. As this stream is mixed with the upstream fraction, there is an emphasis in retaining a high purity in this stream. Assuming the same purity requirement is imposed on NIR machine 7, the material separation matrix of NIR machine 7 targeting clear PET may be similar. Table 6.11 gives a possible material separation matrix for a clear PET-targeting NIR 7.

Table 6.11: Clear PET-targeting NIR machine 7 material separation matrix.

NIR 7 (PET)		
HDPE	1%	99%
Clear PET	39%	61%
Coloured PET	1%	99%
PP	1%	99%
Residue	1%	99%

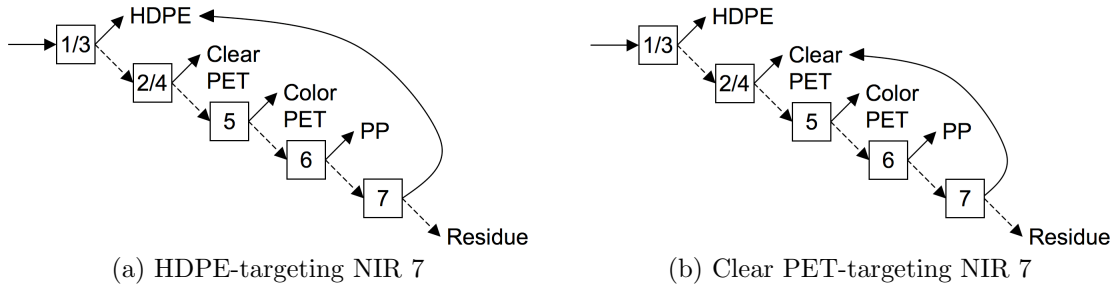

Figure 6-9: Two previously presented configurations for Site B.

### Identifying Profitable Configuration Options for Varying Input Composition

The option to reprogram NIR machine 7 to target HDPE or clear PET creates a choice for the operators at Site B. Since the overall goal of the system is to maximize the profit from recycling, the programming choice should be determined by the economic metric. The choice of target material for NIR machine 7 primarily effects the value of the output materials of that stage. The value of those output materials based on the selection of target material are given in Equation 6.1. The multi-material separation system model will be used to calculate the mass flow rates for the system under each set of targeted material and input composition, and the values calculated can be compared.

First, consider the material input composition estimated as a realistic composition, as given in Table 6.9. This largest individual component of this stream is clear PET plastic, at just over 40%. The economic impact of choosing between the configurations can be found by applying the multi-material separation model with this composition, the two configurations given in Figures 6-9a and 6-9b, and the material separation matrices given in Tables 6.5 and 6.11. Using Equation 6.1 to compare the values of the output materials of the two configurations, we find that

$$\text{Value}_{PET} - \text{Value}_{HDPE} = \pounds 5.42/\text{tonne input} \quad (6.2)$$

That is, when operating on input material with the estimated composition, choosing

to target PET with NIR machine 7 instead of HDPE results in an additional profit per tonne of system input material of roughly £5.50. With the facility’s annual throughput at about 30,000 tonnes, the resulting economic impact of targeting PET in this case could mean an additional £160,000 per year of profits.

Next, consider the input composition given by the operators of Site B as a typical input composition, shown in Figure 6-5. This composition has a much higher fraction of HDPE than the estimated fraction. Again calculating using the multi-material separation system model and Equation 6.1, we find that in this case

$$\text{Value}_{PET} - \text{Value}_{HDPE} = \text{£}2.48/\text{tonne input} \quad (6.3)$$

That is, when operating on input material with the “typical” composition, choosing to target PET with NIR machine 7 instead of HDPE results in an additional profit per input material tonne of roughly £2.50, potentially amounting to £70,000 per year of profits.

In both of these cases, it seems that choosing to target clear PET plastic with the final separation stage is the most profitable option. There are several factors that contribute to the profitability of targeting clear PET. First is that the value of clear PET is higher than that of HDPE on a per tonne basis. Another important factor is the relatively high efficiency of NIR machines 1 and 3 in targeting HDPE. While NIR machines 2 and 4 and machine 5 all target clear PET, their separation efficiencies for that material are not particularly effective. Based on the material separation matrices given in Table 6.5, just under 10% of incoming HDPE is expected to reach NIR machine 7, while slightly over 20% of incoming clear PET reaches that stage.

While this analysis suggests that under most typical operating conditions, targeting clear PET with NIR machine 7 would result in greater profit, there are several considerations that may affect that decision. First, if the material separation matrix for NIR machine 7 processing clear PET overestimates the ability of that process to capture clear PET and reject other plastics, the amount of captured material may decline and the overall purity of the clear PET stream may degrade past the point

where it is salable at the full £230 per tonne price. In this case, it may be that the target output stream of NIR machine 7 is more suitable for combination with the jazz PET output materials. If NIR machine 7 targets both clear and jazz PET with the intent of including that product with the jazz PET material stream, the value of that output drops to £100, lowering the profits associated with that stream. In this case it may be more profitable to target HDPE. Another possible complication with targeting clear PET is that the clear PET output stream is subjected to some hand-picking to achieve the needed color purity. The facility may not be configured in such a way that this second stream could be filtered through hand picking, or the stream may contain too many contaminants for hand picking to be effective.

## 6.3 Energy From Waste

Energy from waste, the process by which wastes, including municipal solid waste and some industrial wastes, are combusted as a fuel for electricity and heat production, is one of many disposal options for waste. In light of increasing fuel costs and landfill disposal costs and improving environmental performance of these facilities, energy from waste is evolving into an important option for waste disposal [113, 157, 114]. Plastics have often been considered an important component in waste-as-fuel due to their high fuel value [40]. On the other hand, in part because of this high energy content, the prices for recycled plastics and the energy flows associated with recapturing this material make capture and recycling of waste plastics also an attractive option [47].

This case study discusses a energy from waste (EfW) facility that is considering installing a plastics reclamation line to capture selected plastics from its waste stream for sale to plastics recyclers. While saving materials and energy may be an added benefit of capturing these materials, the primary motivation is increasing facility profits through the sale of the materials along with the opportunity to process more waste. This case study will address the construction and evaluation of both the material performance and the economic performance of possible systems, as well as provide guidance to the final selection of an appropriate plastics separation system.

### 6.3.1 Facility Description

The energy from waste facility considered in this study processes municipal solid waste, containing a variety of post-consumer waste. Currently, the material is processed before combustion, using shredders, over-band magnetic separators, a light/heavy separator, an eddy current separator, and more, with the intent of removing all valuable metals, including ferrous and non-ferrous metals, and creating smaller particle sizes for combustion.

## Basic Facility Layout

The EfW facility processes the materials, collects the metals, and produces a fuel value-enriched stream, with concentrated levels of plastics and other combustible materials. Currently, the enriched stream is directed to the EfW combustion process. Additional municipal solid waste can be directed to EfW process as needed to supplement the processed waste. This general scheme is shown in Figure 6-10a.

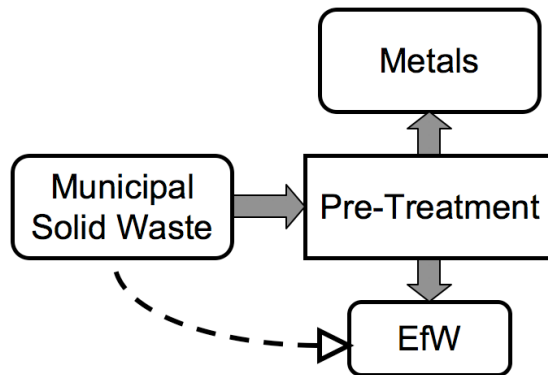

(a) Base configuration of the energy from waste facility.

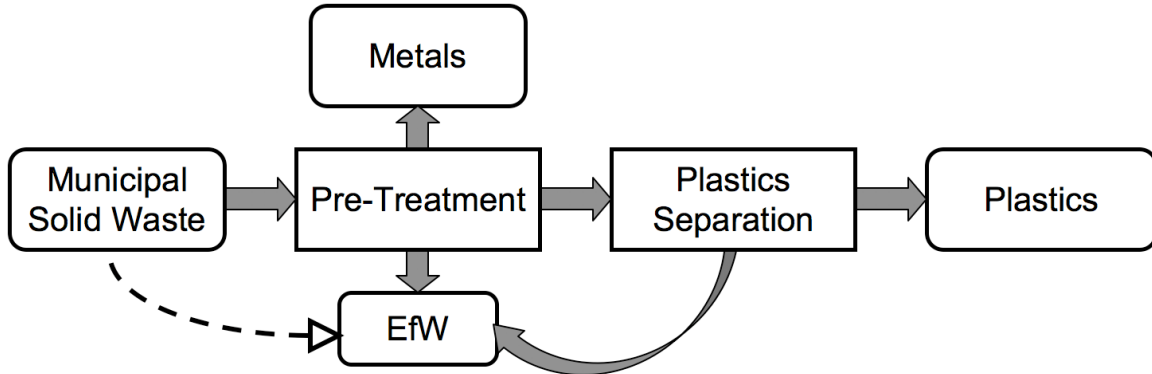

(b) Configuration of the energy from waste facility with plastics separation.

Figure 6-10: Configurations of the energy from waste facility, with and without plastics separation.

## Waste to Energy Considerations

While the primary focus of this case study is whether diverting plastics from the EfW combustion input stream is economically favorable, the energy from waste process is also an important aspect of this problem. The EfW facility requires that the

average energy value of the material flow stream fall in an appropriate range for power generation. In addition, as a power plant, the EfW has an energy production quota. In its basic configuration, the enriched material stream from the pre-treatment processes has enough total energy value to meet the quota, but with additional material capture, municipal solid waste may be used to make up an energy production deficit.

### **Introducing Recycling**

The facility operators for the EfW facility are considering the introduction of additional material separation, with the intent of capturing plastics. This plastics separation line would operate on the plastics-enriched pre-processed stream, which is currently sent directly to the energy from waste process. The plastics processing line will treat some of the output of the pre-treatment process, capturing some plastics but returning much of the stream to the energy from waste process, as shown in Figure 6-10b. Near infrared (NIR) sorting equipment and optical colour sorters can be used to target different types of plastic for capture from the stream. Many target materials and sorter configurations are possible.

### **6.3.2 Modeling Material Performance**

The core of the multi-material separation system modeling technique presented in Chapter 4 is the analysis of material performance. While economics are driving the intent to develop a plastics separating line, the economic and energy performance of the system can be evaluated through the material performance of the system. Evaluating the material performance of the system using the above-mentioned techniques requires the input material composition, the configuration of the separation system, and the separation performance of each of the processes. In this case, configurations are the focus of this case study, and will be discussed in greater depth later. Here, the pre-processed material input stream composition is discussed along with the potential processes for use in the configurations and their performance.

## Pre-processed Material Stream Composition

The EfW facility processes municipal solid waste, consisting primarily of household, post-consumer waste. The pre-treatment processing first sorts particles by size, then removes entangling films and papers before capturing metals for sale. The breakdown of materials in the waste stream before and after pre-treatment is shown in Table 6.12. As shown, the original stream contains roughly 7.5% plastics. In the pre-processed stream, capturable non-film plastics make up about 19% of the treatable stream, with 50% of those plastics being PS/PP. The relatively low fraction of PET and HDPE plastics is due to recycling collection of those materials before the municipal solid waste is sent to the EfW facility. The other major components of the stream are organics and fines, other combustibles and glass. Paper and light films, along with metals, are reduced in proportion to the original stream.

Table 6.12: EfW material stream composition, before and after pre-processing.

Material	Incoming	Pre-processed
Clear PET	0.8%	2.1%
Jazz PET	0.3%	0.7%
Natural HDPE	0.8%	1.9%
Jazz HDPE	0.4%	1.0%
PS/PP	3.8%	9.6%
Other rigids	1.5%	3.8%
Packing film	3.8%	0.4%
Other films	3.8%	0.4%
Paper/Card	21.0%	2.5%
Textiles	2.0%	3.8%
Other combustibles	8.0%	15.5%
Glass	6.0%	11.6%
Other non-combustibles	3.0%	5.8%
Ferrous metals	4.0%	1.6%
Non-ferrous metals	1.0%	0.4%
Organics and fines	40.0%	38.8%



## **Individual Process Performance**

A wide variety of processes can be used to capture plastics, but some of the most effective at capturing plastics from mixed waste are sensor-based processes. In this case study, processes that use near infrared (NIR) and visible range spectroscopy to identify target plastics then eject those target particles with pneumatic jets. Several programming options are possible for the NIR separators, including targeting all non-film plastics, natural or mixed HDPE, natural or mixed PET, PP and jazz HDPE, and PP alone. The optical sorter simply sorts by color and is unable to distinguish between plastic species. These optical color sorters target natural HDPE and clear PET but will collect other natural-colored plastics if they are present in the process's input stream. The material separation matrices for these processes are given in Appendix A.

## **Limitations on Performance Data**

The performance data given in Appendix A, Tables A.1a-d, provide a best estimate of the performance of these sorting processes in their application as part of a plastics processing line. However, many factors can potentially alter the performance of these processes. The condition of materials entering the facility, the placement of the process in the separation configuration, and operational settings may all affect the separator performance for the listed separators.

### **6.3.3 Evaluating Economic Performance Based on Material Performance**

The implementation of the plastics separation line is dependent on profitability, and thus, economic metrics must be defined that can evaluate that profitability. Using the performance data and the multi-material separation system modeling technique, the material flow profile of any physically realistic system can be determined. In this profile, the flow rate of each material at each system process and output are defined. Economic performance can be based on this material flow profile. In this case, we

consider several costs and values, including capital costs of separators and support equipment, the operating costs of this equipment including energy and operator costs, the value of output material systems, the value of energy generated by the system, and the additional tipping fees for processing more waste. Each of these components will be addressed briefly.

## Valuing Outputs

The energy from waste system has two valuable outputs, recyclable metals and energy. The addition of the plastics line adds the option of capturing plastics for recycling, but can also affect the energy production of the facility. The techniques for calculating the revenue generated by the plastic streams and energy production and added gate fees are described here. Other sources of revenue not considered here include tax subsidies for operating a recycling facility and bounties on certain types of packaging.

**Material Values** A plastics separation line is being considered for the energy from waste facility primarily because of the economic possibilities of capturing plastics. Identifying the value of these streams is an important part of creating an economic performance metric for the system. Previously, in Section 5.2.2, several options for valuing plastics streams were discussed. The plastics streams in this case have the potential to be diluted by the variety of other materials in the stream, so a fixed price model may be inadequate. The price-purity relationship described in Equation 5.1, repeated below, is used here.

$$p = \begin{cases} 0 & \text{for } c \leq 0.5 \\ p_{pure}(2c - 1) & \text{for } c > 0.5 \end{cases}$$

Where again,  $p$  is the sale price per tonne,  $p_{pure}$  is the high purity secondary material price per tonne, and  $c$  is the concentration of the desired plastic within the stream. The secondary pure prices for different plastic mixtures are given in Table 6.13.

Table 6.13: Peak sale values for pure, recycled plastics.

Plastics	£/tonne
Nat HDPE bales	200
Jazz HDPE bales	110
Clear PET bales	160
Jazz PET	100
PP bales	100
PP & Jazz HDPE	100
Mixed Plastics bales	80

**Producing Energy** The EfW facility processes the output stream using a combustion process to meet a target quota of roughly 125,000 megawatt hours per year. Energy generated by the energy-to-waste system is valued at £70 per MWh. The total energy output of the system is calculated from the energy-from-waste output stream using the energy values presented in Table 6.14, and the conversion efficiencies of the system. The combined system efficiency, including thermal and electric efficiencies, is roughly 25%. Any deficit in the energy production quota is fulfilled by accepting additional municipal solid waste into the energy-from-waste process. The additional input waste is valued at roughly £95 per tonne. In the case that the process generates extra energy above the plant’s production quota is considered superfluous and is not valued. (A value of £0 per MWh is assigned to the extra energy production.) A check is used to assure that the overall stream heating value is within the acceptable region for operation.

### Evaluating Costs

The profitability of a given plastics separation system is not only a function of its revenues, but also of its costs. In this case, the costs associated with the system are the fixed and operating costs of the equipment required for the plastics separation line. While the revenues generated by the energy from waste system are directly calculated from the mass flow of the materials through the system, the equipment-related costs can be more indirectly related to mass flow. The costs considered are the capital and installation costs for the equipment, operator costs, and the energy

Table 6.14: Energy content for EfW materials.

Material	Energy Value (MJ/kg)
Clear PET	24.6
Jazz PET	24.6
Natural HDPE	24.6
Jazz HDPE	24.6
PS/PP	24.6
Other rigids	24.6
Packing film	24.6
Other films	24.6
Paper/Card	15.5
Textiles	16
Other combustibles	8
Glass	0
Other non-combustibles	0
Ferrous metals	0
Non-ferrous metals	0
Organics and fines	4

use costs for the facility. Other possible costs not addressed here are maintenance costs, equipment replacement costs, financing costs, taxes, and more.

**Capital Equipment and Installation Costs** The capital and installation costs center on the separation equipment used in the plastics separation line. The specified system configurations yield a list of separation processes used in the stages of the line. Modeling techniques used describe the flow of materials through idealized components, while the real systems constructed using available separation equipment that may not have the exact capacity to handle a stream of a given size. An important factor in assigning costs is then the capacity of the individual pieces of equipment. Larger streams in the model may require multiple pieces of equipment to process, while smaller streams may run equipment under capacity. For this analysis, each piece of separation equipment, whether a NIR process or an optical colour sorter, will be priced at roughly £300,000 and the capacity of each piece of equipment will be 10 tonnes per hour. The use factor of the equipment will be assigned at 70%, that is, it is assumed that, due to equipment failure, plant coordination issues, and other

concerns, the average fraction of installed capacity that will be utilized is 70%.

The separation equipment requires additional supporting equipment to function, including conveyer belt systems. This supporting equipment is included in the installation cost and is modeled simply as a fixed portion of the capital cost.

The plastics streams require additional processing equipment outside of the separation line. Each output collected material requires one storage buffer or hopper to collect the streaming material for later packaging. A single baler can be used to prepare the plastics for sale and shipping. Storage buffer cost is roughly £30,000 per stream, while the baler cost is fixed at about £300,000. The installation and support equipment addressed similarly to that of the separation equipment.

**Operator Costs** While the NIR and optical colour separators largely function autonomously, operators are suggested to supervise the the equipment. The number of operators per shift required for a given plastics separating line is based on a combination of units in the line and their capacity. The annual operator costs including all overhead costs is roughly £80,000 per unit per year.

**Energy Consumption** The energy consumption of an individual separation process is very dependent on the physical details of that process. In the case of NIR and optical colour sorters, material feeding and conveyance, the spectrographic scanning, image processing and control computer, and material ejection jets all contribute to the energy use in the process. While some of these energy uses are fixed per unit time, others are variable based on mass throughput. Because the electricity usage for these particular processes are supplied on a per tonne basis, the costs will be scaled directly with stream mass. These costs are roughly £1 per tonne processed for both NIR and optical sorters. The energy use in the hoppers and baler are also given as functions of mass throughput. Energy costs are about £1.50 and £4 per tonne, respectively.

### 6.3.4 Economic Metric: Payback Period

The overall goal of modeling the plastics separation system is to investigate which of many possible configurations of separators can result in profitable material recovery. The total additional capital cost is balanced against the total additional operational profit to find a rough measure of system payback, expressed in years to investment cost payback, as given in Equation 6.4.

$$\text{Payback} = \frac{C_{\text{capital}} + C_{\text{install}}}{R_{\text{plastics}} + R_{\text{elec,add'l}} - L_{\text{operator}} - L_{\text{en,use}}} \quad (6.4)$$

Where Payback is calculated in years, with  $C_{\text{capital}}$  and  $C_{\text{install}}$  as the capital costs and installation costs of the equipment required for the plastics separation line,  $R_{\text{plastics}}$  is the annual revenues generated by the sale of plastics streams,  $R_{\text{elec,add'l}}$  is the annual revenue increase from the sale of electricity produced by the plant including additional municipal solid waste tipping fees,  $L_{\text{operator}}$  is the annual cost of operator staffing, and  $L_{\text{en,use}}$  is the annual cost of energy diverted for use in the facility. In general, the calculated payback period would probably be shorter than the real payback period due to the lack of financing impacts, choices in uplift costs, taxes, and models of equipment utilization. This measure of payback is used to compare possible system configurations. Systems whose costs exceed their revenues are regarded as unprofitable in this evaluation, and the payback period is considered undefined.

### 6.3.5 Selecting Configurations with Plastics Recovery Economics

Selecting an appropriate plastics separation line to construct as part of the energy from waste facility is challenging because of the large number of potential output products and the multiple configurations that could be used to target each set of products. With as few as two separation stages, the options for process selection, system configuration, and output material grading allows for thousands of plastics

line configurations. Manually investigating the performance of these configurations with common techniques such as the flowsheets discussed in Sections 3.1.1 and 4.1.1 is prohibitive. Combining the multi-material separation system modeling technique presented in Chapter 4, which allows for simple algorithmic evaluation of system material performance, with iterative enumeration techniques may uncover system configurations that may not have been considered under the manual system configuration generation.

This case study uses multi-material separation system modeling to analyze the material performance of possible configurations. The programmatic solution technique can be paired with automatic configuration generation algorithms to exhaustively explore the possible configurations within any given configuration space defined by restrictions on the number of stages, their types, or the connections allowed between stages. The economic metric of payback period, described in Section 6.3.4, is used to compare the performance of the different separation system configurations.

### **Best Options at Given Plant Complexity**

While the goal of the plastics line is an economic one, there are many ways to approach this goal. Exploring the relative economic performance of separation systems with similar configurations provides insight into the factors that effect economic performance. Comparing separation systems with the same level of complexity identifies the best economic performance for a given level of capital expenditure.

**Systems of One Stage** The simplest type of possible system configuration is one consisting of a single step. The analysis presented here considers all the possible configurations of a single step, including all the possible process selections and all possible salable material options. The material flow and economic benefits of the system configuration are calculated as described above, and the payback period for each configuration is calculated. The payback of computer-generated system configurations will be compared to a manually selected single step configuration, which uses an HDPE/PET/PP NIR separator to capture a mixed plastics output stream. Figure

6-11 shows the separation systems whose revenues exceed costs, leading to defined payback periods. In these diagrams, processing stages are represented in blue, with primary outputs represented in red, and secondary outputs represented in yellow. Salable outputs are represented in red and the energy for waste stream is represented in yellow.

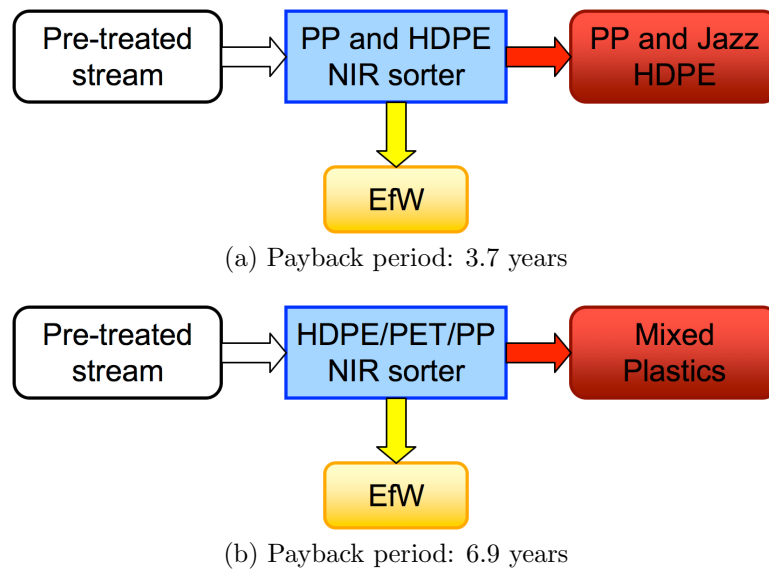

Figure 6-11: Profitable single separation process configurations and their payback periods.

The shortest payback period is for a system using a polypropylene (PP) and Jazz high-density polyethylene (HDPE) NIR sorter stage, as shown in Figure 6-11a. The payback period for this system is approximately 3.7 years, while the payback period of the system employing a mixed plastic NIR sorter, which targets HDPE, polyethylene terephthalate (PET), and PP, is a longer, 6.9 years as shown in Figure 6-11b. The difference is explained by the difference in output stream quality, due to the generally better rejection rate for non-plastic materials. This higher quality creates a much higher sale price for the recycled materials, enough to compensate for the difference in stream bulk. PP/PS makes up the majority of the plastics output stream from the pre-treatment processing, so while the total stream mass is less than the HDPE, PET, and PP NIR sorter system, it still has a significant volume.

An important consideration for the PP and Jazz HDPE NIR sorter system is



whether or not the separation performance data given for that sorter is intended for use with dirty incoming flows. It may be that the separation data given for the PP and Jazz HDPE NIR sorter is intended for use with already-refined mixed plastic streams, which may also be the case for the optical colour sorter. If so, the profitability of the PP and Jazz HDPE NIR sorter system may drop, increasing the payback period. A decrease of 1% in the rejection success rate of non-desirable materials puts the payback period of the system on par with that of the HDPE, PET, and PP NIR sorter system. In all system configurations, economic concerns can also change the profitability of the system. The system is especially sensitive to changes in sale price of material and operating costs of machinery, such as operator costs or energy prices. The system's profitability is less sensitive to changes in capital costs.

**Systems of Two Stages** Next we consider systems with two separation stages. Rather than compare all profitable system configurations, the systems with the shortest payback periods under different limitations on the processes used and their configurations are considered. Figure 6-12 show the top performing configurations of two stages under a variety of conditions, along with their payback periods, in years.

Under an open selection process, allowing any choice for both of the two separation processes, the shortest payback period is 3.4 years. This configuration, shown in Figure 6-12a, utilizes two PP and Jazz HDPE NIR sorters. These sorters are very effective for separating these plastics from all other waste streams, creating a relatively pure output PP and jazz HDPE stream. This smaller stream has a high per tonne value, and requires less processing energy and support equipment for the plastics storage and recovery stream. The great success of this system is dependent on the high performance of the PP and Jazz HDPE NIR sorters. PP and Jazz HDPE NIR sorters are more successful here than in the case of the single step configurations because the heightened stream concentration along with the supplemental mixed plastics stream decreases the payback period.

Other system configurations perform with nearly as good a payback period. Figure 6-12b shows the best system where no processes are repeated within the system.

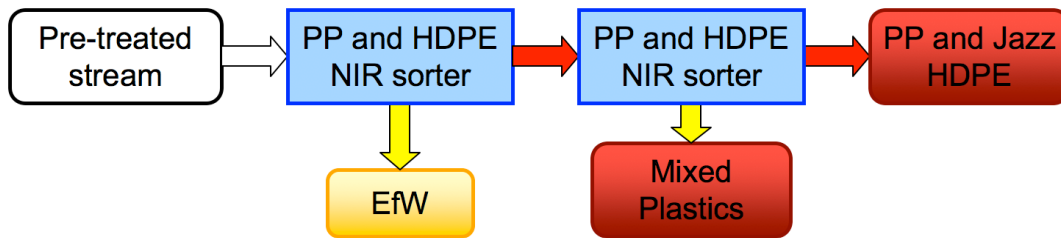

(a) Any process and configuration allowed. Payback period: 3.4 years

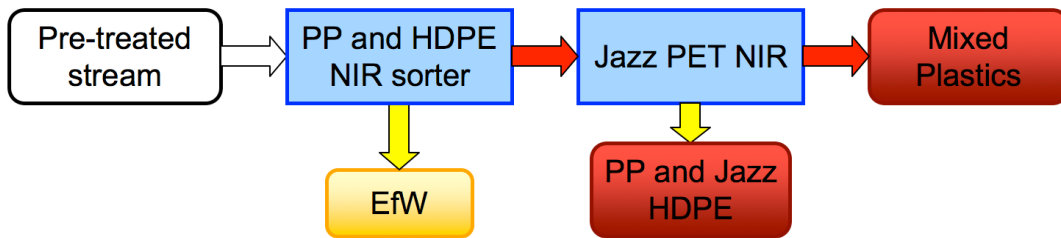

(b) No repeated processes. Payback period: 3.7 years

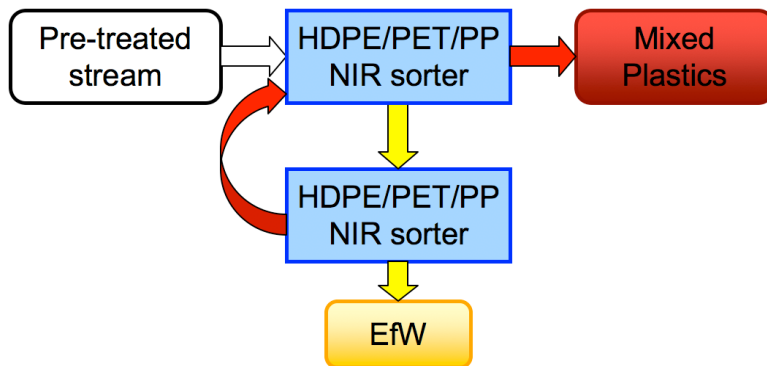

(c) First process forced to be an all-plastics NIR separator. Payback period: 4.7 years

Figure 6-12: Configurations of two stages with shortest payback periods under a variety of conditions.

This configuration has a payback period of roughly 3.7 years, with outputs of mixed plastic and PP and Jazz HDPE streams. In this case, the system produces two plastics streams, both with relatively high volume. The PP and Jazz HDPE stream is relatively pure, while the mixed plastics stream is of somewhat low grade. The energy-from-waste process is supplemented with extra municipal solid waste, increasing profitability for that configuration. These systems rely on the greater effectiveness of the PP and HDPE NIR sorter, along with the high representation in the pre-treated stream of the plastics targeted by this sorter. A belief that the high performance of these separators can be maintained at any point of placement within the separation

system is required to recommend these two configuration.

Many hand-selected flowsheets feature an all-plastics HDPE/PET/PP NIR sorter as the first separation stage, ostensibly because all the desirable plastics are targeted by this process. Figure 6-12c shows the best performing configuration that starts with an HDPE/PET/PP NIR sorter. This configuration has a payback period of 4.7 years, not as favorable as the openly configurable systems, but still an acceptable level of performance. The HDPE/PET/PP NIR sorter doesn't capture target materials or reject target materials as well as the PP and HDPE NIR sorter, which can explain this reduction in performance.

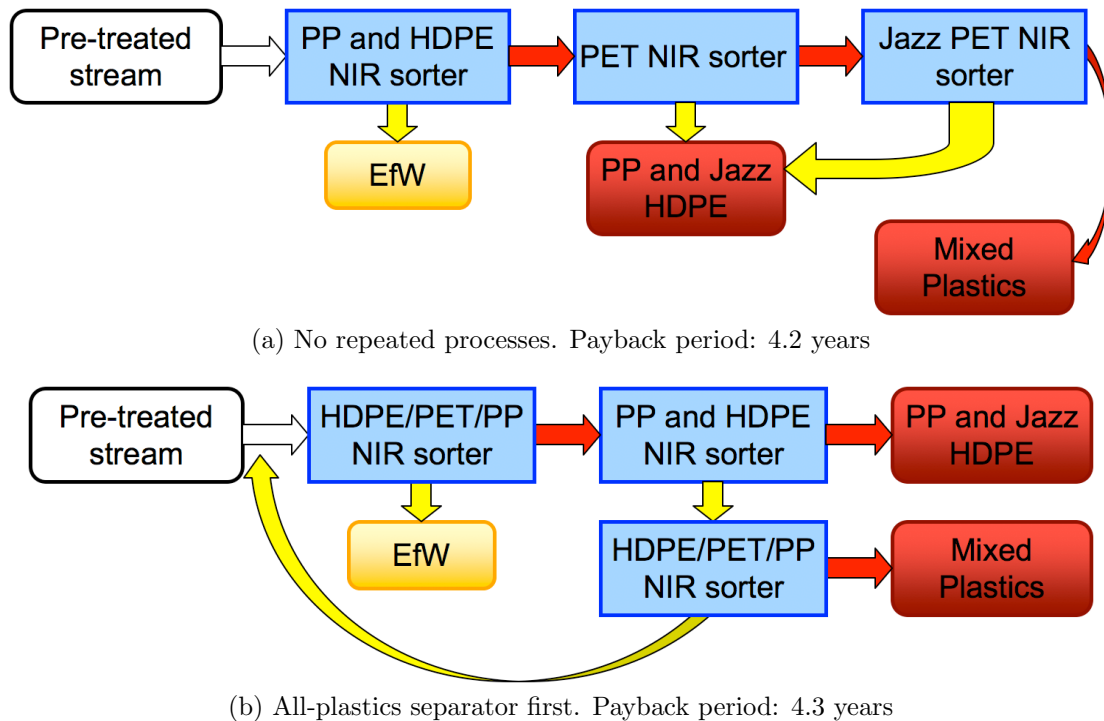

Figure 6-13: Configurations of three stages with shortest payback periods under a variety of conditions.

**Systems of Three Stages** The optimal system shown in Figure 6-13a allowing for any process, with no repeated processes, has a payback period of 4.2 years. Again, the ability of the early stage sorters to maintain a high level of performance while processing very mixed material is critical to the profitability of this system configuration. When looking at these configurations for three separation steps, it should

be noted that the two-stage configuration under the same limitations as the configuration depicted in Figure 6-13a outperforms the three-stage configuration, but the three-stage configuration with a forced first separation stage shown in Figure 6-13b outperforms the two-stage separation process under that same configuration. Extra stages may add capital costs and some operating costs without providing a significant gain in output material recovery or values.

Configurations with larger numbers of steps also have the potential to achieve good payback periods. Figure 6-14 shows a high performing system of four stages, with the first stage forced to be an all plastics sorter and no repeated stages. The payback period is slightly longer than that for the three stage system with similar limiting conditions, but still comparable.

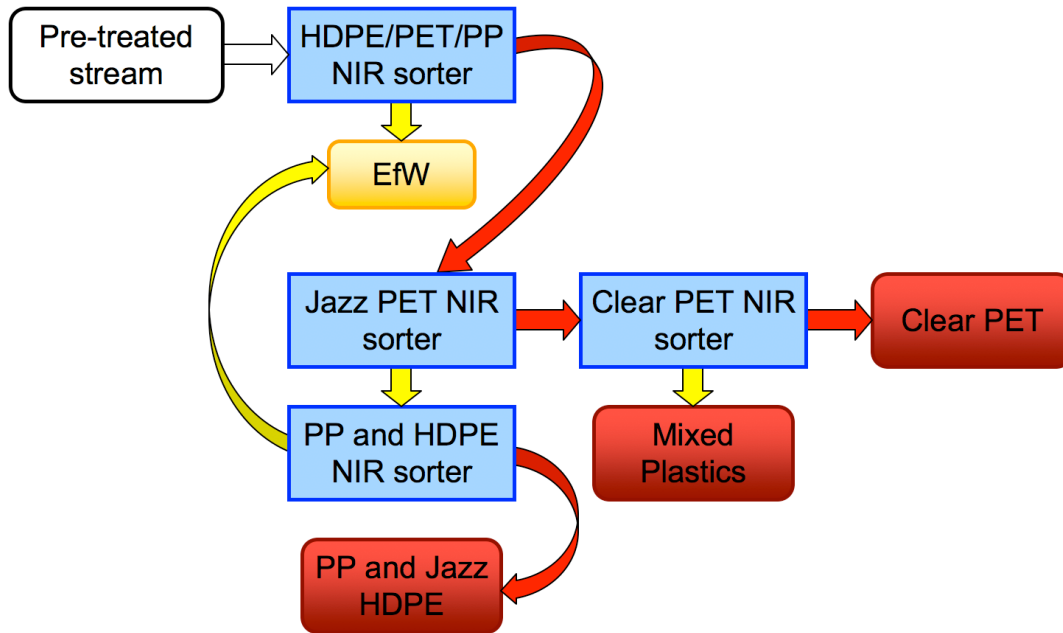

Figure 6-14: Configuration of four stages with shortest payback period with an all-plastics separator first and no repeated stages. Payback period: 4.6 years.

In the case of configurations that produce “clear” or “natural” plastics streams, an option for improving payback period would be adding hand sorting on those plastics to improve purity. While there is very little capital cost associated with setting up a hand sorting station, operator costs can contribute significantly to hourly costs. As clear PET in this case is a very small output stream, it would be possible to hand

sort the material in larger-volume batches rather than as a continuous flow as part of the main separation system. This would reduce operator costs.

### **Comparison to Existing Flow Sheets**

The configurations described in Section 6.3.5 include the best performing configurations automatically generated under a variety of conditions on processes and configurations. The systems created have relatively short payback periods of a few years. The forms of these systems might be described as unpredictable; the first separation stage is not often an all-plastics sorter, internally circulating streams occur, the same process may be used in multiple stages, the output material streams do not always correspond with what you might expect from the immediately preceding separation process. This could imply that manually configured separation systems may have longer payback periods than the automatically generated optimal systems. However, in many cases there are many system configurations with very similar economic performance. It may be that manually suggested configurations have similar payback periods to the best automatically generated ones. The relationship in payback period for hand-selected configurations and automatically generated ones is explored in this section.

The simplest system proposed in a manually generated flow sheet is the same configuration as shown in Figure 6-11b, featuring a single HDPE/PET/PP NIR sorter. This system delivers a payback period of about 7 years. The best automatically generated system of a single step, shown in Figure 6-11a, has a payback period half that length. The PP and Jazz HDPE NIR separator used in that configuration delivers more value, as explained earlier. Again, the high volume of PP and HDPE in the stream and its moderate value, combined with the efficient performance of the PP and Jazz HDPE NIR separator, account for the difference in payback period.

A similar case is found for other manually selected systems. Figure 6-15 shows a flowsheet intended to capture “naturals”, high-value uncolored HDPE and PET streams, which provides a supplementary mixed plastics output stream. The payback period for this “naturals” flowsheet is 23.3 years. In a constructed realization of this

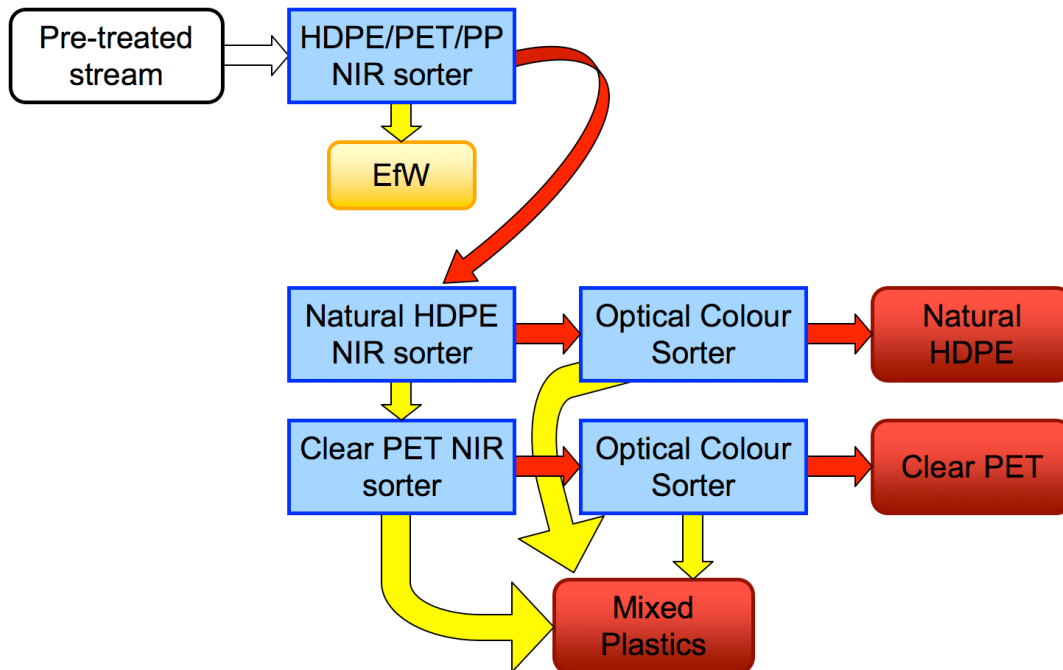

Figure 6-15: A manually configured flowsheet focusing on extracting high value “naturals”, including natural HDPE and clear PET.

system, the two optical colour sorting stages would be served by a single optical colour sorter, which would sort the HDPE and PET streams in campaigns. This is taken into account in the cost model used to calculate the payback period for the naturals. To contrast, the best automatically generated flow sheet of a similar size, given in Figure 6-14, even with its restricted conditions, has a significantly shorter payback period of 4.6 years. Unexpected material outputs, such as the PP and Jazz HDPE stream that appears in nearly all of the best performing systems, can capture greater overall value than the expected high-value but low volume streams such as the naturals. Manually selected flow sheets, even those constructed logically, may not represent the best choice for system operation.

### Additional Considerations

While the goal of installing a plastics separation line at the energy from waste facility is economic in nature, there are many aspects to the economic evaluation. The preceding analysis primarily centers on the economic metric of payback period, as de-

scribed in Section 6.3.4. Other possible sources of costs and revenues were mentioned briefly, but beyond the details of the calculation of payback, there are other issues surrounding the installation of such a facility. One is the availability of capital. The ability to purchase and install any plastics line is dependent on the outlay of capital that is acceptable to the facility's operators. In general, our analysis has found that smaller systems have the shortest payback periods, so focusing on a smaller, more affordable plastics line may be a viable strategy. Larger systems, while they may have longer payback periods, may result in overall higher lifetime profit due to a higher cash flow associated with the facility once it is running. Additionally, the analysis presented here does not take any variability or risk into account. Properly weighing these additional aspects of economic performance are necessary to make a comprehensive judgement about the best plastics separation line for the energy from waste facility.

### **6.3.6 Energy from Waste Summary**

The analysis presented in this chapter is a real-world application of the multi-material separation system modeling technique presented in Chapter 4. Using these modeling techniques, many possible plastics separation systems were explored for their economic value. Separation system configurations with payback periods of less than 4 years were uncovered, outperforming the manually selected flowsheets profiled. The plastics streams with the shortest payback periods had some surprising characteristics as mentioned on page 149, including repeated separation stages and unexpected output materials.

Several important concepts arose in the course of this analysis, both with respect to the construction of a plastics separation line, and with respect to the application of the multi-material separation system modeling analysis. In the construction of the line, this analysis has uncovered that manually selected flowsheets may have poorer performance than automatically generated ones, due to the unpredictable usage of separation processes, target materials, and re-entrant material streams. Another finding is that larger plastics separation systems with more refined or higher-value

outputs may not be more economically effective than smaller systems.

In terms of the analysis, one important concept is that the overall predicted performance of a given separation system configuration can be sensitive to the variation of the processes' separation performance. Accurate performance data is necessary for accurate modeling. Another result is that many configurations have similar economic performance. Determining the best plastics separation line for the facility may require grading systems with similar payback periods on other aspects of performance, including sensitivity to change in performance and input materials, trade-offs between capital intensity and overall size of revenue stream, and more.



## 6.4 Energy From Waste: Alternate Scenario

The analysis of the energy from waste facility described in Section 6.3 considers a scenario where the input material stream fed into the pre-treatment process is a fixed size. This section considers instead an alternate scenario where the pre-treatment process is scalable to accommodate any amount of extra input material with little difficulty or cost change. The modifications to the system model, along with new system designs under this alternate configuration.

### 6.4.1 Facility Description

Again, the energy from waste facility considered in this study processes municipal solid waste, containing a variety of post-consumer waste. Currently, the material is processed before combustion, using shredders, over-band magnetic separators, an eddy current separator, and more, with the intent of removing all valuable metals, including ferrous and non-ferrous metals, and creating smaller particle sizes for combustion.

#### Basic Facility Layout

The EfW facility processes the materials, collects the metals, and produces a fuel value-enriched stream, with concentrated levels of plastics and other combustible materials. Currently, the enriched stream is directed to the EfW combustion process. This general scheme is shown in Figure 6-16a.

All materials entering the energy-from-waste process are outputs of the pre-treatment process. The amount of material processed by the system scaled such that these outputs produce the electricity quota of the plant when combusted in the EfW process.

Again, the facility operators for the EfW facility are considering the introduction of additional material separation, with the intent of capturing plastics, both generating revenue from selling the plastics and reducing the total fuel value entering the EfW process, allowing for additional municipal solid waste to be fed into the system. The plastics separation line would operate on the plastics-enriched pre-processed stream,

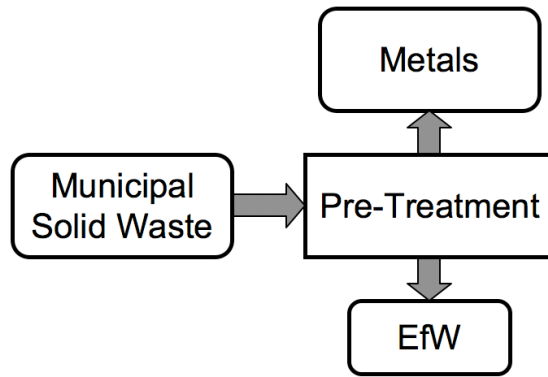

(a) Base configuration of the energy from waste facility.

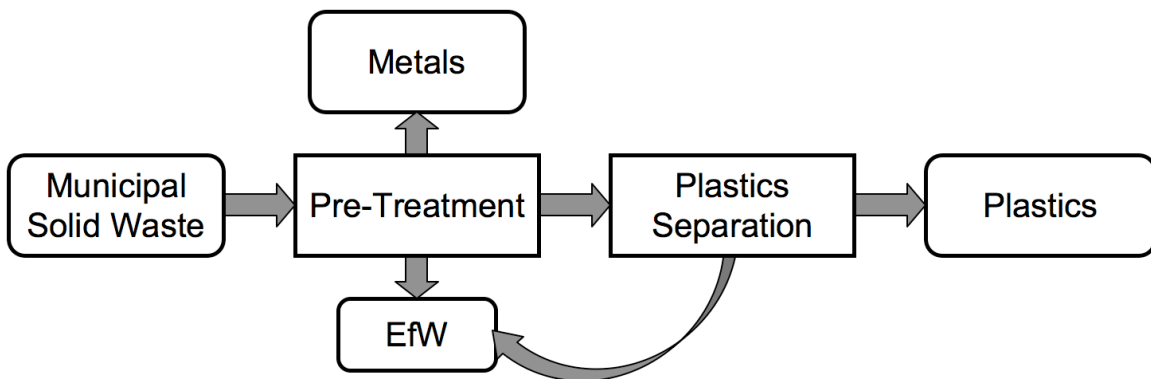

(b) Configuration of the energy from waste facility with plastics separation.

Figure 6-16: Alternate scenario configurations of the energy from waste facility, with and without plastics separation.

which is currently sent directly to the energy from waste process. The plastics processing line will treat some of the output of the pre-treatment process, capturing some plastics but returning much of the stream to the energy from waste process, as shown in Figure 6-16b. Near infrared (NIR) sorting equipment and optical colour sorters can be used to target different types of plastic for capture from the stream. Many target materials and sorter configurations are possible.

### 6.4.2 Modeling Material Performance

In this scenario, the modeling techniques described in Section 6.3 are used with some alterations that reflect the new strategy of incorporating more municipal solid waste in the pre-treatment processing.

## **Pre-processed Material Stream Composition**

The EfW facility processes municipal solid waste, consisting primarily of household, post-consumer waste. The pre-treatment process includes several separation stages, whose outputs are combined and collected as ferrous and non-ferrous metals and fuel for the energy-from-waste process. Some of the outputs currently directed to the energy-from-waste process can be recombined into plastics-enriched streams. In this case, two additional streams are formed, a plastics-enriched stream, and a light materials stream. Some materials are still sent directly to the EfW process.

The breakdown of materials in the waste stream as it enters the system as municipal solid waste, the fraction that is grouped together to form the plastics-enriched stream, and the fraction gathered as light materials is shown in Table 6.12. As shown, the original stream contains roughly 7.5% plastics. In the plastics-enriched stream, capturable non-film plastics make up about 19% of the treatable stream, with 50% of those plastics being PS/PP. The other major components of the stream are organics and fines, other combustibles and glass. Paper and light films, along with metals, are reduced in proportion to the original stream. The light materials stream is roughly half paper, and roughly a quarter plastic films. The plastics-enriched stream and the films stream have roughly the same mass flow rate.

## **Individual Process Performance**

The same plastics separators considered in the original case study for the energy-from-waste facility, as given in Section 6.3, are again considered for use here. These processes include NIR processes and optical color sorters with performance as described in Appendix A. A new type of NIR sorter is included in this case study: a NIR sorter designed to target plastic films. The performance of this sorter is given in Table A.1e.

Table 6.15: EfW material stream composition, before processing, for plastics-enriched stream, and for light material stream.

Material	Incoming	Plastics-Enriched	Lights
Clear PET	0.8%	2.1%	0.5%
Jazz PET	0.3%	0.7%	0.2%
Natural HDPE	0.8%	1.9%	0.5%
Jazz HDPE	0.4%	1.0%	0.2%
PS/PP	3.8%	9.6%	2.4%
Other rigids	1.5%	3.8%	1.0%
Packing film	3.8%	0.4%	11.9%
Other films	3.8%	0.4%	11.9%
Paper/Card	21.0%	2.5%	49.5%
Textiles	2.0%	3.8%	1.0%
Other combustibles	8.0%	15.5%	4.0%
Glass	6.0%	11.6%	3.0%
Other non-combustibles	3.0%	5.8%	1.5%
Ferrous metals	4.0%	1.6%	2.0%
Non-ferrous metals	1.0%	0.4%	0.5%
Organics and fines	40.0%	38.8%	9.9%

### 6.4.3 Evaluating Economic Performance Based on Material Performance

The implementation of the plastics separation line is dependent on profitability, and thus, economic metrics must be defined that can evaluate that profitability. Again, performance data and the multi-material separation system modeling technique are used to predict the material flows at each system process and output, and economic performance is based on this material flow profile. The economic evaluation has many common components with those described in Section 6.3.3, which will be mentioned briefly here.

#### Valuing Materials

The energy-from-waste facility produces several outputs, including materials and energy. In this case, material input to the facility is scaled so that the energy production exactly matches the facility's target energy production, but the quantities of captured

output materials vary. These output materials can include salable plastics streams, captured high-energy-value films intended for landfill, and ferrous and non-ferrous metals.

**Valuing Plastics** In this alternate scenario, plastics values are determined in the same manner as the original case study. Equation 5.1 is again used to determine the value of the materials based on purity, using the peak sale values for recycled plastics as given in Table 6.13.

**Valuing Metals** While the original separation system for the energy-from-waste facility captures ferrous and non-ferrous metals, the increasing total input mass to the system increases the amount of metals produced by the system. The added metals output is valued similarly to the collected plastics. Again, Equation 5.1 is used to calculate the sale price per tonne based on material purity and peak pure price. In the case of metals, the peak pure price for both the ferrous and the non-ferrous stream is £40 per tonne.

**Producing Energy** The EfW facility processes the output stream using a combustion process to meet a target quota of roughly 125,000 megawatt hours per year. Energy generated by the energy-to-waste system is valued at £70 per MWh. The energy output of the system is calculated from the energy-from-waste output stream using the energy values presented in Table 6.14, and the conversion efficiencies of the system. The combined system efficiency, including thermal and electric efficiencies, is roughly 25%. The municipal solid waste input to the system is scaled so that the annual energy production of the facility remains 125,000 MWh per year. The opportunity to increase the volume of waste processed by the EfW facility is an opportunity to gain revenues from tipping fees for that waste. Additional input waste is valued at roughly £95 per tonne. A check is used to assure that the overall stream heating value is within the acceptable region for operation.

**Films Costs** With the possible addition of the NIR film sorter, a new potential source of cost must be considered. While the energy value of the materials captured by the NIR film sorter is high, the material is not a salable output and must instead be diverted to landfill at a cost of £95 per tonne. While capturing films incurs a disposal cost, the high fuel value of these materials allows for a larger portion of additional input materials. The gate fees for these materials may offset the landfill cost of the collected films.

### **Evaluating Operating and Capital Costs**

The economic evaluation has many common components with those described in Section 6.3.3, which will be mentioned briefly here. The costs considered are the capital and installation costs for the equipment, operator costs, and the energy use costs for the facility. Other possible costs not addressed here are maintenance costs, equipment replacement costs, financing costs, taxes, and more.

**Capital Equipment and Installation Costs** The capital and installation costs center on the separation equipment used in the plastics separation line. Again, each piece of separation equipment, whether a NIR process (including film NIR processes) or an optical colour sorter, will be priced at roughly £300,000 and the capacity of each piece of equipment will be 10 tonnes per hour. The same use factor of 70% applied in the original analysis will be used here. Supporting equipment is again modeled as a fixed portion of the capital cost. Buffers and bailers are addressed similarly to the separation equipment.

**Operator Costs** Again, the annual operator costs including all overhead costs is roughly £80,000 per unit per year.

**Energy Consumption** Again, energy costs will be scaled directly with stream mass. These costs are roughly £1 per tonne processed for both NIR and optical sorters. The energy use in the hoppers and baler are also given as functions of mass throughput. Energy costs are about £1.50 and £4 per tonne, respectively.

#### **6.4.4 Economic Metric: Payback Period**

The same economic metric of payback discussed in Section 6.3.4 will be used in this alternate scenario. This measure is constructed by balancing the total additional capital against the total additional operational profit to find a rough measure of system payback, expressed in years to investment cost payback, as given in Equation 6.4.

#### **6.4.5 Selecting Configurations with Plastics Recovery Economics**

The goal of this case study is to identify systems with short payback periods under the conditions listed in the preceding sections. Multi-material separation system modeling is used to analyze the material performance of possible configurations. Again, automatic configuration generation algorithms are used to exhaustively explore the possible configurations within any given configuration space defined by restrictions on the number of stages, their types, or the connections allowed between stages. The economic metric of payback period is used to compare the performance of the different separation system configurations.

Several factors differ between the original energy-from-waste case and this alternate scenario, that will be reflected in the resulting effective separation systems. The ability to incorporate additional input waste for added revenue greatly affects which of the system configurations are the most economically effective. Typically, system configurations calculated to have the shortest payback period in this scenario are different than those that are found for the original study in Section 6.3.5. It should be noted that the payback periods between these two case studies should not be compared due to the different methods used to calculate them.

The system of a single stage with the shortest payback period is shown in Figure 6-17. This system uses a single NIR separator targeting mixed plastics. This system has a payback period of approximately 0.52 years.

This system is economically favorably because the diversion of the mixed plastics

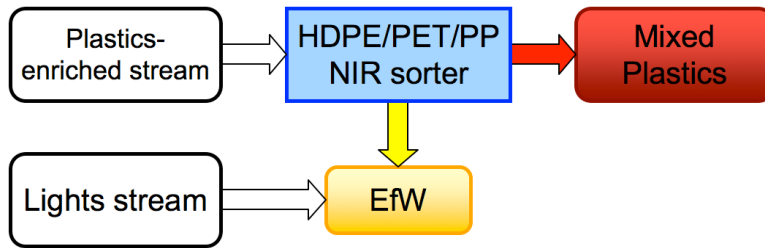

Figure 6-17: Alternate scenario system of a single stage with the shortest payback period. Payback period 0.52 years.

alone allows the system to process roughly 13% more material than in the base case with no plastics separation. This increased waste throughput accounts for over 2 million additional pounds of tipping fees at the facility per year, while the annual revenue from plastics sales is roughly £600,000. In the particular case of systems with one separation stage and in general in this scenario, the most economically favorable system configurations are typically those that capture a large volume of materials for recycling or external disposal, allowing for increasing gate fees for municipal solid waste.

Figure 6-18 shows the system of two separation stages with the shortest payback period, roughly 0.50 years. This system captures mixed plastics for sale and plastic films for disposal, allowing for an increase in input materials of over 48%. The increase in gate fees, roughly an additional eight million pounds per year, collected through this additional input waste accounts for the success of this system. The film collection components of the system and the mixed plastics components of the system largely run in parallel, doubling the capital costs over the most effective system of a single step shown in Figure 6-17. While the increase in input MSW volume and the corresponding revenue from that waste is greater than triple that of the best one stage system, the disposal of the captured films incurs a high cost, countering the increasing revenue and creating a configuration with roughly the same payback period.

Figure 6-19 shows the system of three separation stages with the shortest payback period, roughly 0.55 years. The increase in input municipal solid waste for this system is 48%, the same as in the case of the best two stage system, leading to the two system



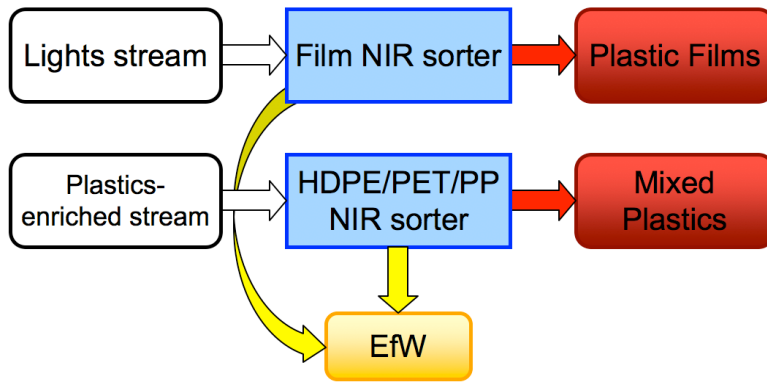

Figure 6-18: Alternate scenario system of two stages with the shortest payback period. Payback period 0.50 years.

configurations having the same increased revenue from gate fees for MSW. While the revenues from the plastics are increased by segregating the captured plastics into PP and Jazz HDPE and mixed plastics, the added income does not compensate for the added capital costs of installing the PP and Jazz HDPE NIR separator and its supporting equipment.

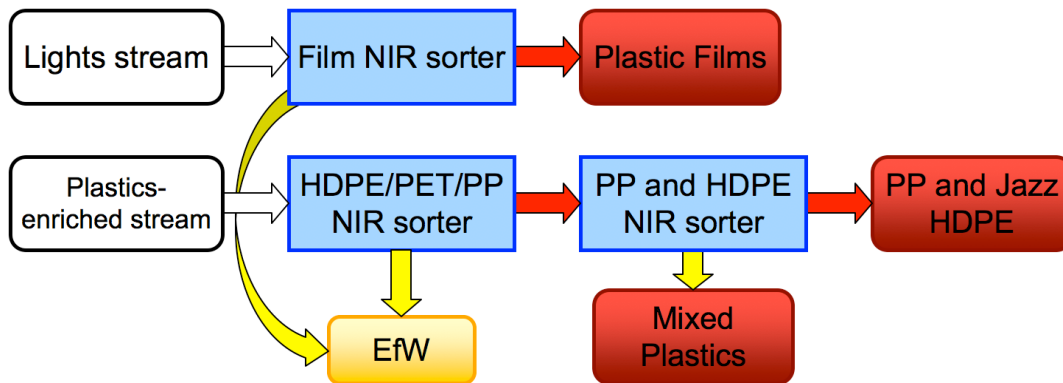

Figure 6-19: Alternate scenario system of two stages with the shortest payback period. Payback period 0.55 years.

System configurations with added separation stages trend toward having higher payback periods, for the reasons touched on for separation systems of three stages. The revenue increase from capturing refined plastics streams does not compensate for the added capital cost of the equipment needed to refine the plastics. The ability to remove plastics from the energy-from-waste stream is central to the economic

performance of the system, rather than the ability to refine plastics. On the other hand, additional plastics removal from the heavy plastics stream beyond that achieved by a single mixed plastics NIR separator is less economically effective than a system using a single stage. Figure 6-20 shows the a separation system configuration using a second stage to capture additional plastics from the plastics-enriched stream.

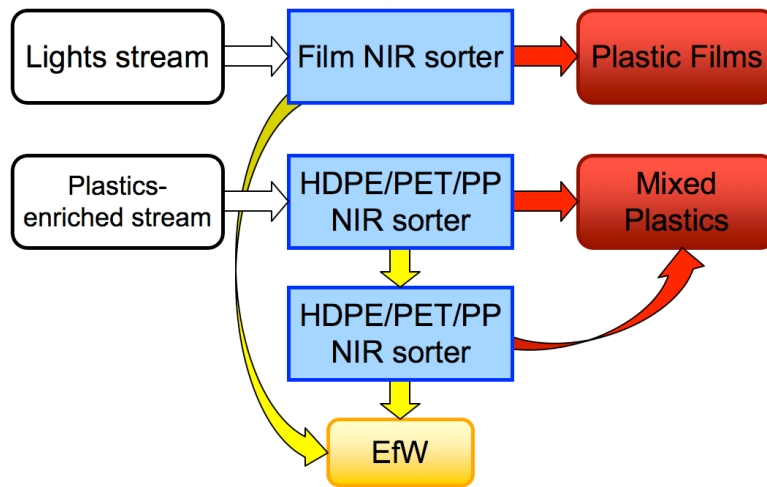

Figure 6-20: Alternate scenario system of three stages using two mixed plastics capture stages. Payback period 0.71 years.

The payback period of this system is 0.71 years. The second mixed plastics separation stage processes the secondary output stream of the first mixed plastics separation stage. This output contains far fewer plastics, as this first stage captures roughly 80% of the desirable plastics from the plastics-enriched stream. While this stream contains only 20% of those desirable plastics, the total mass of material is over 80% of the original plastics-enriched stream. This high volume of material leads to high processing and capital equipment costs, but the relatively low concentration of desirable plastics leads to this second stage having a relatively small output stream of plastics. Effectively, the low concentration of plastics in the input of the second mixed plastics separation stage leads to the reduced effectiveness of this system configuration.

## Comparison to Existing Flow Sheets

The configurations described in Section 6.4.5 include the best performing configurations automatically generated under a variety of conditions on processes and configurations for this alternate scenario. The systems created have relatively short payback periods of less than a year. As mentioned in Section 6.4.5, the most favorable system of a small size includes both a film separator and a mixed plastics separator, capturing enough plastics to increase the amount of material processed by the system by roughly 50%. Systems including additional stages intended to purify plastics had more capital costs that were not balanced out by the increased plastics revenue.

User-selected systems include some of the more favorable selections suggested by the above analysis, as well as some less favorable system configurations. The simplest system proposed in a manually generated flow sheet is the same configuration as shown in Figure 6-17, featuring a single HDPE/PET/PP NIR sorter, which is the system of a single step with the shortest payback period. The best performing configuration found in this alternate scenario, shown in Figure 6-18, is also identified in a user-selected flow sheet.

Other user-selected flow sheets did not fair as well, particularly those with many plastics purifying stages. For example, Figure 6-15 shows a flowsheet intended to capture “naturals”, high-value uncolored HDPE and PET streams, which provides a supplementary mixed plastics output stream. The payback period for this “naturals” flowsheet is 0.86 years. User-selected configurations include systems with even more purifying stages, such as the system shown in Figure 6-21.

This system, which produces all individual plastics sorts, has a payback period of over a year. The additional capital cost to sort the mixed plastics into the whole range of species and colors is not justified by the additional revenues. The cascading collection from the high volume secondary output process streams greatly increases the capital costs to well over four million pounds. Additionally, many of the collected plastics species are gathered at such a low concentration as to be value-less.

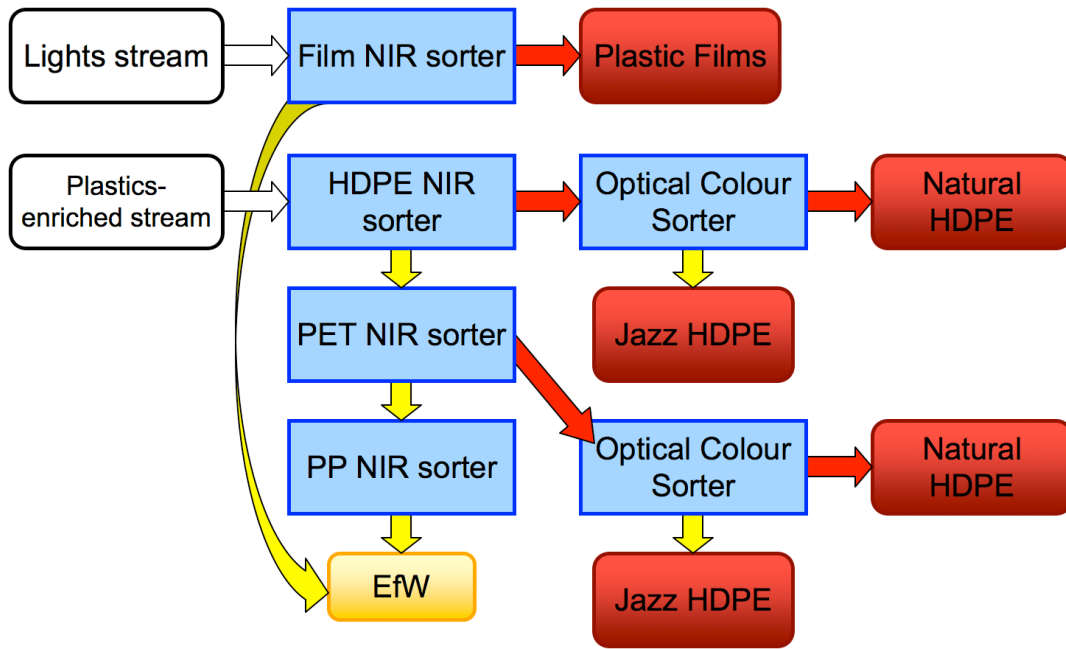

Figure 6-21: Alternate scenario user selected configuration sorting for all individual plastics. Payback period 1.1 years.

### Additional Considerations

While the goal of installing a plastics separation line at the energy from waste facility is economic in nature, there are many aspects to the economic evaluation. The preceding analysis primarily centers on the economic metric of payback period, as described in Section 6.3.4. Other issues also surround the installation of such a facility. One is the availability of capital. The ability to purchase and install any plastics line is dependent on the outlay of capital that is acceptable to the facility's operators. In general, our analysis has found that smaller systems have the shortest payback periods, so focusing on a smaller, more affordable plastics line may be a viable strategy.

With the short payback periods found for many systems, of about a year or less, the focus may instead be on the net change in operating income. As the bulk of the revenue increase in the systems described in this section comes from the extra gate fees from added input municipal solid waste, those systems that are able to capture large volumes of high energy value plastics and increase the input mass flow will have

the greatest operating income. In this case, the system shown in Figure 6-20 has the highest increase in operating income, of over six million pounds per year. This system filters material from the plastics-enriched stream twice in conjunction with a film separator used on the light material stream, pulling out more high fuel value plastics, increasing revenues from gate fees for municipal solid waste. The system with the shortest payback period, shown in Figure 6-18, also fares well, with an operating income increase of roughly five and a half million pounds per year. Systems with additional separation stages, including the “Naturals” configuration and the all-sorts configuration, had lower operating income changes.

#### **6.4.6 Energy from Waste Summary**

Several important concepts arose in the course of this analysis, both with respect to the construction of a plastics separation line, and with respect to the application of the multi-material separation system modeling analysis. In the construction of the line, this analysis has uncovered that the removal of high energy value plastics from the EfW streams generated additional revenue primarily by increasing the amount of waste that could be processed by the system, leading to additional gate fees. Larger plastics separation systems that refine and capture plastics streams with high sale value are generally less economically effective than smaller systems that focus on removing the key plastics components from the EfW streams.

This analysis has also shown that different economic goals can yield different results. Focusing on payback period highlights certain system configurations, that have both good increases in revenue and effective use of capital, while focusing on potential gain in revenue yields different system configurations. While different system configurations are favored by these two metrics, the best systems under each metric also fair well under the other.



# Chapter 7

## Conclusions

This thesis has developed and discussed new modeling techniques for material separation systems with applicability to material recycling. The binary material separation system model and the multi-material separation system model are both suited for modeling material recycling systems because of their ease of formulation, basic process performance data requirements, and ability to analyze any realistic separation system configuration. The multi-material separation system model has the added benefit of capturing the behavior of separation systems and processes treating multiple materials, a common feature of real recycling systems.

### 7.1 Model Performance

The binary material separation system model and the multi-material separation system model capture the material behavior of separation systems. Chapters 3 and 4 present several theoretical case studies that showcase the basic performance of the modeling techniques. As stated in the goals of this work, the model is capable of formulating solvable systems of mass balance equations for material separation systems that can capture any realistic configuration and include any type of separation process. The theoretical examples demonstrate that the models can capture and evaluate the material performance any physically possible configuration. These examples also demonstrate that the models can be formulated and solved algorithmically, as

shown by their use in enumerating and solving all possible cases within a given set of parameters, for example, as in Section 3.3.2 where all configurations of two stages with identical performance are investigated.

## **7.2 Applicability to Real Systems**

Where Chapters 3 and 4 discuss theoretical separation systems, Chapter 6 show the application of the binary material separation system model and the multi-material separation system model to real separation systems.

### **7.2.1 Material Predictions**

The case studies given in Chapter 6 all evaluate the material performance of their respective systems as a first step. While some of the cases model systems that have not yet been constructed, in some of the case studies there are existing models or real separation system performance can provide a basis for evaluating the performance of the multi-material separation system model. In Section 6.2, the multi-material separation system model is used to mirror measured output material performance. Table 6.10 shows the close match in material output performance. In the energy from waste case study presented in Section 6.3, the multi-material separation system model was able to match the mass flows presented in existing flow sheets, such as those given in Section 6.3.5, exactly.

### **7.2.2 Economics**

Economic forces drive most recyclers. While many recyclers are part of for-profit operations, even those that operate for compliance reasons should run as economically efficiently as possible. The multi-material separation system model evaluates the material performance of the system, which can be used as a basis to construct economic metrics, as suggested in Section 5.2.2. Output material sale value, equipment capital costs, labor costs, maintenance and operational costs, and more can be based on



mass flows. These revenues and costs can be combined into economic metrics, such as capital intensity and payback period, that reflect the economic performance of a given separation system configuration. The case studies given in Sections 6.2 and 6.3 use economic metrics based on real data to compare possible separation system configurations. Other measures of system performance, including energy and environmental impact, can also be based on the mass flow rates captured by the binary and multi-material separation system models.

## **7.3 Contributions of this Work**

While models for separation systems based on material performance do exist, the model presented in this thesis improves upon them in the ways suggested in Section 1.2.2. The binary material separation system model and multi-material separation system model and related work presented in this thesis represent a new direction for separation system modeling, focused on the inclusive and flexible modeling of material recycling systems.

### **7.3.1 Flexible Modeling of Binary and Multi-Material Separation Systems**

The binary and multi-material separation system models as given in this work model material separation systems that utilize any type of separation process and any configuration that diverts whole output streams, including those that have internally recirculating streams. As stated in Section 1.2.2, current separation system models typically feature either completely flexible configuration options, or the ability to capture any type of process. By using high level models for both system configuration and process performance, the binary and multi-material separation system models are able to deliver a model able to realistically capture the relevant behavior of material recycling systems including any configuration and any selection of processes. Another important aspect of these models is generation of the system mass balance equations

from configuration and separation performance data. This direct generation allows for the algorithmic generation and solution of the system's mass balance equations to determine the mass flow performance of a given system. This ability is important for use in the exploration of system configurations, particularly for optimization.

### **Multi-Material Separation Efficiencies**

An important component of the binary and multi-material separation system models is the models used for separation performance. In the case of the binary material separation system model, the Bayesian material separation performance model captures the performance of a separation process for two materials. The material separation matrix model developed in this work takes the same approach, giving separation efficiencies for all the materials entering a separation process. Similarly, the separation efficiencies used in a material separation matrix can be measured experimentally or estimated using physical process models. Again, as many real recycling systems treat multi-material mixtures, the development of a cohesive model for representing the separation efficiency of a process treating multiple materials is an important step in creating accurate models of recycling systems.

### **7.3.2 Effects of Variation on Separation Process Performance**

Another important contribution of this thesis is the investigation of the effects of variation on separation process performance, presented largely in Chapter 5, in Section 5.1.3. Existing models that acknowledge that variations in input material mix and operational parameters can affect separation performance are typically physical models, that require detailed models of the physical effects within a process and of the incoming material stream particles. The Bayesian separation performance model and the multi-material separation matrix model are well suited to capturing the effects of variation on process performance. Several examples are given relating these effects, including the examples of concentration dependence and output division adjustment. While this thesis acknowledges the importance of this field and demonstrates how to

approach modeling these effects of variation and incorporate them into larger system models, it is an area that is ripe for further study, as suggested below in Section 7.4.1.

## 7.4 Future Work

While the models presented in this thesis provide a basic technique that can be used to capture the behavior of many material separation systems, in particular those for material recycling, additional features could enhance these models in some cases.

### 7.4.1 Parameter Variability in Individual Processes

As discussed in Chapter 5, the performance of separation processes can be affected by many factors, including process operational parameters and input material variation. The Bayesian separation model and the multi-material separation matrix model reflect the performance of a separation process at a fixed set of operational parameters and input materials. For some of these process specifications, varying them has no effect on separation efficiencies, while others can have a significant effect on the performance of the process.

Currently, most of the models for capturing the relationship between different operational parameters and input materials and separation performance are physical models, such as those for eddy current separators presented by Rem et al. [116]. Models of this type require detailed physical models of the effects within a process along with a detailed material characterization. These models can be used to predict the performance of any set of materials and operational parameters, but are computationally intensive. Another possible approach would be to characterize the performance of a process experimentally, varying different parameters and investigating the resulting separation performance, creating a functional relationship without a physical basis.

## 7.4.2 Embedding Individual Process Models

As mentioned in the preceding section, process material performance can vary based on material condition and operational parameters. Currently, the binary material separation system model and the multi-material separation system model sidestep this issue by using material separation efficiencies taken for processes operating under similar conditions. This is an effective strategy in part because the material conditions within a separation system do not vary significantly, and thus separation data measured for a component within an existing system may be applied to that process at another placement or configuration of the same system. However, in some cases, the variation in material condition may have an effect. For example, concentration changes within a given system, so if the performance of a process is susceptible to changes with changes in input material concentrations, then incorporating a process model into the larger separation system model is necessary. It may also be the case that the ability to adjust process performance can provide additional opportunities to improve performance, as in the magnetic roller case study presented in Section 6.1. While adding process performance models where applicable increases the accuracy of the model, the optimization problem becomes more challenging. This can be seen in mineral froth flotation models, where a wide variety of optimization algorithms and strategies have been applied in an attempt to tame the increasing complexity of systems with individual process models [59, 170, 102, 24, 65, 64].

## 7.4.3 Incorporating Comminution

Another common feature of material recycling systems is comminution. Comminution processes in separation systems, such as shredders, are designed to reduce particle sizes and liberate materials from each other with the intent of improving downstream material separation. Comminution features in many types of material recycling system, from electronic equipment [31] to end-of-life vehicles [99]. While a large body of work on comminution exists in mineral processing, the focus in that case is on brittle materials. The study of the comminution of non-brittle materials is a relatively new

field. The comminution of metals has been the focus of most of the studies of comminution in recycling systems [85, 158, 125, 126], but some studies have focused on the comminution of organic [106] and non-brittle [130] materials. On the other hand, models for material recycling can find guidance on incorporating these comminution processes within system models from mineral processing [80, 118, 23, 25]. The effects of comminution on the performance of recycling systems is an area of increasing interest [20, 62].



# Appendix A

## Material Separation Matrices for Energy from Waste Processing

Table A.1: NIR process multi-material separation efficiencies.

(a)

Material	HDPE/PET/PP NIR Sorter		Natural HDPE NIR Sorter	
	$R_p$	$R_s$	$R_p$	$R_s$
Clear PET	0.8	0.2	0.1	0.9
Jazz PET	0.8	0.2	0.1	0.9
Natural HDPE	0.8	0.2	0.9	0.1
Jazz HDPE	0.8	0.2	0.2	0.8
PS/PP	0.8	0.2	0.1	0.9
Other rigids	0.4	0.6	0.1	0.9
Packing film	0.3	0.7	0.1	0.9
Other films	0.3	0.7	0.1	0.9
Paper/Card	0.1	0.9	0.1	0.9
Textiles	0.01	0.99	0.1	0.9
Other combustibles	0.01	0.99	0.1	0.9
Glass	0.1	0.9	0.1	0.9
Other non-combustibles	0.08	0.92	0.08	0.92
Ferrous metals	0.02	0.98	0.02	0.98
Non-ferrous metals	0.02	0.98	0.02	0.98
Organics and fines	0.08	0.92	0.08	0.92

Material	Clear PET NIR Sorter		PET NIR Sorter	
	$R_p$	$R_s$	$R_p$	$R_s$
Clear PET	0.9	0.1	0.8	0.2
Jazz PET	0.2	0.8	0.8	0.2
Natural HDPE	0.1	0.9	0.1	0.9
Jazz HDPE	0.1	0.9	0.1	0.9
PS/PP	0.1	0.9	0.1	0.9
Other rigids	0.1	0.9	0.1	0.9
Packing film	0.1	0.9	0.1	0.9
Other films	0.1	0.9	0.1	0.9
Paper/Card	0.1	0.9	0.1	0.9
Textiles	0.1	0.9	0.1	0.9
Other combustibles	0.1	0.9	0.1	0.9
Glass	0.1	0.9	0.1	0.9
Other non-combustibles	0.08	0.92	0.1	0.9
Ferrous metals	0.02	0.98	0.1	0.9
Non-ferrous metals	0.02	0.98	0.1	0.9
Organics and fines	0.08	0.92	0.1	0.9

(b)

Material	PP/Jazz HDPE NIR Sorter		HDPE NIR Sorter	
	$R_p$	$R_s$	$R_p$	$R_s$
Clear PET	0.1	0.9	0.1	0.9
Jazz PET	0.1	0.9	0.1	0.9
Natural HDPE	0.1	0.9	0.8	0.2
Jazz HDPE	0.9	0.1	0.8	0.2
PS/PP	0.9	0.1	0.1	0.9
Other rigids	0.1	0.9	0.1	0.9
Packing film	0	1	0.1	0.9
Other films	0	1	0.1	0.9
Paper/Card	0	1	0.1	0.9
Textiles	0	1	0.1	0.9
Other combustibles	0	1	0.1	0.9
Glass	0	1	0.1	0.9
Other non-combustibles	0	1	0.1	0.9
Ferrous metals	0	1	0.1	0.9
Non-ferrous metals	0	1	0.1	0.9
Organics and fines	0	1	0.1	0.9

(c)



	PP NIR Sorter		Optical Sorter	Colour Sorter
Material	$R_p$	$R_s$	$R_p$	$R_s$
Clear PET	0.1	0.9	0.9	0.1
Jazz PET	0.1	0.9	0.03	0.97
Natural HDPE	0.1	0.9	0.9	0.1
Jazz HDPE	0.1	0.9	0.03	0.97
PS/PP	0.8	0.2	0.08	0.92
Other rigids	0.1	0.9	0.03	0.97
Packing film	0.1	0.9	0.08	0.92
Other films	0.1	0.9	0.08	0.92
Paper/Card	0.1	0.9	0.03	0.97
Textiles	0.1	0.9	0.03	0.97
Other combustibles	0.1	0.9	0.03	0.97
Glass	0.1	0.9	0.08	0.92
Other non-combustibles	0.1	0.9	0.08	0.92
Ferrous metals	0.1	0.9	0.02	0.98
Non-ferrous metals	0.1	0.9	0.08	0.92
Organics and fines	0.1	0.9	0.03	0.97

(d)

	Film NIR Sorter	
Material	$R_p$	$R_s$
Clear PET	0.2	0.8
Jazz PET	0.2	0.8
Natural HDPE	0.2	0.8
Jazz HDPE	0.2	0.8
PS/PP	0.2	0.8
Other rigids	0.2	0.8
Packing film	0.97	0.03
Other films	0.97	0.03
Paper/Card	0.95	0.05
Textiles	0.2	0.8
Other combustibles	0.2	0.8
Glass	0.2	0.8
Other non-combustibles	0.2	0.8
Ferrous metals	0.2	0.8
Non-ferrous metals	0.2	0.8
Organics and fines	0.2	0.8

(e)



# Bibliography

- [1] Dominic K. Albino. Bayesian material separation: Analysis of multiple recycling streams. Senior project in applied math, Yale University, 2007.
- [2] Julian M. Allwood, Jonathan M. Cullen, and Rachel L. Milford. Options for achieving a 50% cut in industrial carbon emissions by 2050. *Environmental Science & Technology*, 44(6):1888–1894, 2010.
- [3] Harvey Alter. The recovery of plastics from waste with reference to froth flotation. *Resources, Conservation and Recycling*, 43(2):119 – 132, 2005.
- [4] S. Arai, S. Ito, E. Oi, H. Yotsumoto, E. Kikuchi, and H. Sakamoto. Study of the dry separation of plastics using a column-type air separator. In *Proceedings of the Annual Meeting of MIMIJ*, page 110, 1995.
- [5] Michael F. Ashby. *Materials and the Environment: Eco-informed Material Choice*. Butterworth-Heinemann, Burlington, Massachusetts, 2009.
- [6] Firas Awaja and Dumitru Pavel. Injection stretch blow moulding process of reactive extruded recycled pet and virgin pet blends. *European Polymer Journal*, 41(11):2614 – 2634, 2005.
- [7] Allmineral allflux upflow separator trial report. Technical report MDP033/023 WEEE Separation techniques, Axion Consulting, WRAP (Waste & Resources Action Programme), 2010.
- [8] Titech nir sorting trial report. Technical report MDD018/23 WEEE Separation techniques, Axion Consulting, WRAP (Waste & Resources Action Programme), 2010.
- [9] Visys multi frequency laser trial report. Technical report MDD018/23 WEEE Separation techniques, Axion Consulting, WRAP (Waste & Resources Action Programme), 2010.
- [10] Delft university of technology kinetic gravity separator trial report. Technical report MDD018/23 WEEE Separation techniques, Axion Consulting, WRAP (Waste & Resources Action Programme), 2010.

- [11] Holman wilfley wet shaking table trial report. Technical report MDD018/23 WEEE Separation techniques, Axion Consulting, WRAP (Waste & Resources Action Programme), 2010.
- [12] Y. Barba-Gutiérrez, B. Adenso-Díaz, and M. Hopp. An analysis of some environmental consequences of European electrical and electronic waste regulation. *Resources, Conservation and Recycling*, 52(3):481 – 495, 2008.
- [13] Best genius optical sorter. Available at <http://www.bestsorting.com/recycling/sorters/genius-optical-sorter/>. Accessed on May 23, 2011.
- [14] P. Bevilacqua, P. Bozzato, and G. Ferrara. Analysis of dense medium circuit for separating plastics. In *Proceedings of the XX International Mineral Processing Congress*, number 5, pages 383–394, Aachen, Germany, 21-26 September 1997.
- [15] B.C. Braam, H.J.L. Van Der Valk, and W.L. Dalmijn. Eddy-current separation by permanent magnets part ii: Rotating disc separators. *Resources, Conservation and Recycling*, 1(1):3 – 17, 1988.
- [16] Ludwig Brands, Peter-M. Beier, and Ingo Stahl. *Electrostatic Separation*. Wiley-VCH Verlag GmbH & Co. KGaA, 2000.
- [17] Boma Molly Brown-West. A strategic analysis of the role of uncertainty in electronic waste recovery system economics: an investigation of the IT and appliance industries. Master’s thesis, Massachusetts Institute of Technology, Engineering Systems Division, June 2010.
- [18] Electronic Waste Recycling Act (SB 20, 2003, Sher, and SB 50, 2004, Sher). California senate bill. Available online at [http://www.dtsc.ca.gov/HazardousWaste/EWaste/MoreInfo.cfm#Electronic\\_Waste\\_Recycling\\_Act](http://www.dtsc.ca.gov/HazardousWaste/EWaste/MoreInfo.cfm#Electronic_Waste_Recycling_Act). Accessed April 19, 2011.
- [19] Boston zero-sort recycling: A casella program. distributed by and property of Casella Waste Systems, 2009.
- [20] M.B. Castro, J.A.M. Remmerswaal, J.C. Brezet, A. van Schaik, and M.A. Reuter. A simulation model of the comminution-liberation of recycling streams: Relationships between product design and the liberation of materials during recycling. *International Journal of Mineral Processing*, 75(3-4):255 – 281, 2005.
- [21] Jen-Shih Chang, Arnold J. Kelly, and Joseph M. Crowley. *Handbook of Electrostatic Processes*. CRC Press, 1995.
- [22] P.F. Chapman and F. Roberts. *Metals Resources and Energy*. Butterworth-Heinemann, London, 1983.
- [23] L.A. Cisternas, E.D. Gálvez, and D.A. Méndez. Optimal design of flotation circuits including selection of bank cells, column cells and regrinding mills. 2nd Mercosur Congress on Chemical Engineering, 4th Mercosur Congress on Process Systems Engineering, Rio de Janeiro, August 2005.

- [24] Luis A. Cisternas, Edelmira D. Gálvez, María F. Zavala, and Julio Magna. A MILP model for the design of mineral flotation circuits. *International Journal of Mineral Processing*, 74:121–131, 2004.
- [25] Luis A. Cisternas, David A. Mndez, Edelmira D. Glvez, and Rodrigo E. Jorquera. A milp model for design of flotation circuits with bank/column and regrind/no regrind selection. *International Journal of Mineral Processing*, 79(4):253 – 263, 2006.
- [26] Coca-Cola Enterprises, Inc. 2010 annual report: Building on success. Available at <http://www.cokecce.com/>, Atlanta, Georgia, 2010. Accessed on April 7, 2011.
- [27] Marcello Colledani, Stanley B. Gershwin, Timothy G. Gutowski, and Malima I. Wolf. A methodology to support the design of multi-stage material separation systems for recycling. In *Proceedings of the 43rd CIRP International Conference on Manufacturing Systems*, Vienna, Austria, May 2010.
- [28] Stephen Cooney. Steel: Price and policy issues. Report for Congress RL32333, Congressional Research Service, The Library of Congress, Washington, DC, 31 August 2006.
- [29] Thomas A.M. Counsell and Julian M. Allwood. Reducing climate change gas emissions by cutting out stages in the life cycle of office paper. *Resources, Conservation and Recycling*, 49(4):340 – 352, 2007.
- [30] Amelia L. Craighill and Jane C. Powell. Lifecycle assessment and economic valuation of recycling: A case study. *Resources, Conservation and Recycling*, 17:75–96, 1996.
- [31] Jirang Cui and Eric Forssberg. Mechanical recycling of waste electric and electronic equipment: a review. *Journal of Hazardous Materials*, B99:243–263, 2003.
- [32] J. B. Dahmus and T. G. Gutowski. What gets recycled: An information theory based model for product recycling. *Environmental Science & Technology*, 41:7543–7550, 2007.
- [33] J.B. Dahmus, S.A. Fredholm, E.A. Olivetti, J.R. Gregory, and R.E. Kirchain. Modeling the economic and environmental performance of recycling systems. In *Electronics and the Environment, 2008. ISEE 2008. IEEE International Symposium on*, pages 1 –6, May 2008.
- [34] J.B. Dahmus and T.G. Gutowski. Material recycling at product end-of-life. In *Electronics and the Environment, 2006. Proceedings of the 2006 IEEE International Symposium on*, pages 206 –211, may 2006.

- [35] I. Daigo, D. Fujimaki, Y. Matsuno, and Y. Adachi. Development of a dynamic model for assessing environmental impact associated with cyclic use of steel. In *Proceedings, The 6th international conference on EcoBalance, Tsukuba October*, volume 2004, pages 25–27, 2004.
- [36] L. Dascalescu, A. Mizuno, R. Tobazeon, P. Atten, R. Morar, A. Iuga, M. Mihailescu, and A. Samuila. Charges and forces on conductive particles in roll-type corona-electrostatic separators. *Industry Applications, IEEE Transactions on*, 31(5):947–956, September/October 1995.
- [37] Deutsche Gesellschaft für Kreislaufwirtschaft und Rohstoffe mbH. *Plastics Recycling Current Product Specifications*. Available at <http://www.gruener-punkt.de/en/waste-management/downloads/plastics-recycling.html>. Accessed on April 9, 2011.
- [38] Deutsche Gesellschaft für Kreislaufwirtschaft und Rohstoffe mbH. *Product Specification Fraction-No. 320*, April 2009. Available at [http://www.gruener-punkt.de/uploads/media/320\\_Mixed\\_Plastic\\_Bottles.pdf](http://www.gruener-punkt.de/uploads/media/320_Mixed_Plastic_Bottles.pdf).
- [39] Jo P. Dewulf and Herman R. Van Langenhove. Quantitative assessment of solid waste treatment systems in the industrial ecology perspective by exergy analysis. *Environmental Science & Technology*, 36(5):1130–1135, 2002.
- [40] Luis F. Diaz, George M. Savage, Linda L. Eggerth, and Larry Rosenberg. Solid waste management, volume 1. Technical report, CalRecovery Incorporated, United Nations Environment Program, 2005.
- [41] P. Dinger. Automatic sorting for mixed plastics. *BioCycle*, 33:80–82, 1992.
- [42] G. Dodbiba and T. Fujita. Progress in separating plastic materials for recycling. *Physical Separation in Science and Engineering*, 13(3-4):165–182, September-December 2004.
- [43] G. Dodbiba, N. Haruki, A. Shibayama, T. Miyazaki, and T. Fujita. Combination of sinkfloat separation and flotation technique for purification of shredded PET-bottle from PE or PP flakes. *International Journal of Mineral Processing*, 65:11–29, 2002.
- [44] G. Dodbiba, A. Shibayama, T. Miyazaki, and T. Fujita. Separation performance of PVC and PP plastic mixture using air table. *Physical Separation in Science and Engineering*, 12:71–86, 2003.
- [45] G. Dodbiba, A. Shibayama, J. Sadaki, and T. Fujita. Combination of triboelectrostatic separation and air tabling for sorting plastics from a multi-component plastic mixture. *Materials Transactions*, 44(12):2427–2435, 2003.

- [46] Natalia Duque Ciceri. *Methodology to Estimate Product Embodied Energy and Potential Recovery through Recycling: An Application of Industrial Sustainability*. PhD dissertation, Politecnico di Milano, Department of Management, Economics, and Industrial Engineering, January 2011.
- [47] Materials characterization paper in support of the final rulemaking: Identification of nonhazardous secondary materials that are solid waste scrap plastics. Available online at <http://www.epa.gov/wastes/nonhaz/define/pdfs/plastics-final.pdf>. Accessed April 14th, 2011, Environmental Protection Agency, 3 February 2011.
- [48] Directive 2000/53/EC of the European Parliament and of the Council of 18 September 2000 on end-of life vehicles. Commission Statements. Available online at <http://eur-lex.europa.eu/LexUriServ/LexUriServ.do?uri=CELEX:32000L0053:EN:NOT>. Accessed April 21, 2011.
- [49] Directive 2002/96/EC of the European Parliament and of the Council of 27 January 2003 on waste electrical and electronic equipment (WEEE). Joint declaration of the European Parliament, the Council and the Commission relating to Article 9. Available online at <http://eur-lex.europa.eu/LexUriServ/LexUriServ.do?uri=CELEX:32002L0096:EN:NOT>. Accessed April 19, 2011.
- [50] J. Florestan, A. Lachambre, N. Mermilliod, J.C. Boulou, and C. Marfisi. Recycling of plastics: automatic identification of polymers by spectroscopic methods. *Resources, Conservation and Recycling*, 10:67 – 74, 1994.
- [51] Alastair Fuad-Luke. *ecoDesign: The Sourcebook*. Chronicle Books, 2006.
- [52] M. C. Fuerstenau and Kenneth N. Han, editors. *Principles of Mineral Processing*. Society for Mining Metallurgy & Exploration, 2003.
- [53] T. Fujita, Y. Kamiya, N. Shimizu, and T. Tanaka. Basic study of polymer particles separation using vibrating feeder and electrostatic high voltage generator. In *Proceedings of the Third International Symposium on East Asian Resources Recycling Technology*, pages 155–164, 1995.
- [54] Jane Gardner, Andrew Mail, Liz Morrish, Roger Morton, Nicola Myles, and Simon Wilkinson. Good practice of near infrared sorting of plastic packaging. Technical report MDP033, Axion Consulting, WRAP (Waste & Resources Action Programme), 2010.
- [55] Gabrielle G Gaustad. *Towards sustainable material usage: time-dependent evaluation of upgrading technologies for recycling*. PhD dissertation, Massachusetts Institute of Technology, Department of Materials Science and Engineering, June 2009.
- [56] Kenneth Geiser and Barry Commoner. *Materials Matter: Toward a Sustainable Materials Policy (Urban and Industrial Environments)*. The MIT Press, 2001.

- [57] Gregory M. Gelles. Aluminum recycling economics. In Mark E. Schlesinger, editor, *Aluminum Recycling*, chapter 4. CRC Press, 2006.
- [58] S. B. Gershwin. *Manufacturing Systems Engineering*. Prentice-Hall, 1994. For corrections, see <http://web.mit.edu/manuf-sys/www/gershwin.errata.html>.
- [59] J. C. A. Green. The optimisation of flotation networks. *International Journal of Mineral Processing*, 13(2):83 – 103, 1984.
- [60] J. Gregory, J. Atlee, and R. Kirchain. A process-based model of end-of-life electronics recycling driving eco-efficiency-informed decisions. In *Electronics and the Environment, 2006. Proceedings of the 2006 IEEE International Symposium on*, pages 138 –143, May 2006.
- [61] Jeremy R. Gregory and Randolph E. Kirchain. A framework for evaluating the economic performance of recycling systems: A case study of North American electronics recycling systems. *Environmental Science & Technology*, 42(18):6800–6808, 2008.
- [62] Amedeo Grotti and Davide Veroux. Modeling and optimization of multi-stage shredding-separation systems for recycling. Laurea specialistica project, Politecnico di Milano, Facoltà di Ingegneria dei Sistemi, 2010.
- [63] Jr. Guide, V. Daniel R., Vaidyanathan Jayaraman, Rajesh Srivastava, and W. C. Benton. Supply-chain management for recoverable manufacturing systems. *Interfaces*, 30(3):125–142, 2000.
- [64] Chandan Guria, Mohan Verma, Santosh K. Gupta, and Surya P. Mehrotra. Simultaneous optimization of the performance of flotation circuits and their simplification using the jumping gene adaptations of genetic algorithm. *International Journal of Mineral Processing*, 77(3):165 – 185, 2005.
- [65] Chandan Guria, Mohan Verma, Surya P. Mehrotra, and Santosh K. Gupta. Multi-objective optimal synthesis and design of froth flotation circuits for mineral processing, using the jumping gene adaptation of genetic algorithm. *Industrial & engineering chemistry research*, 44(8):2621 – 2633, 2005.
- [66] T. Gutowski, J. Dahmus, A. Thiriez, M. Branham, and A. Jones. A thermodynamic characterization of manufacturing processes. In *Proceedings of the 2007 IEEE International Symposium on Electronics and the Environment*, pages 137–142. IEEE, 2007.
- [67] T.G. GUTOWSKI. Material recycling in OECD countries: Environmental benign manufacturing and material processing toward dematerialization. *Materials transactions-JIM*, 43(3):282–284, 2002.



- [68] Timothy G. Gutowski, J. B. Dahmus, D. K. Albino, and Matthew S. Branham. Bayesian material separation model with applications to recycling. In *International Symposium on Electronics and the Environment*, Orlando, FL, 7-10 May 2007. IEEE.
- [69] Timothy G. Gutowski and Jeffrey B. Dahmus. Product recycling systems. In *NSF Design Service and Manufacturing Grantees and Research Conference*, Scottsdale, AZ, 3-6 January 2005.
- [70] Timothy G. Gutowski and Malima Isabelle Wolf. Separation and energy use performance of material recycling systems. In *NSF CMMI Engineering Research and Innovation Conference*, Honolulu, HI, 22-25 June 2009.
- [71] Timothy G. Gutowski, Malima Isabelle Wolf, J. B. Dahmus, and D. K. Albino. Analysis of recycling systems. In *NSF CMMI Engineering Research and Innovation Conference*, Knoxville, TN, 7-10 January 2008.
- [72] H. Hatayama, H. YAMADA, I. DAIGO, Y. MATSUNO, and Y. ADACHI. Dynamic substance flow analysis of aluminum and its alloying elements. *Materials transactions*, 48(9):2518–2524, 2007.
- [73] G.L. Hearn and J.R. Ballard. The use of electrostatic techniques for the identification and sorting of waste packaging materials. *Resources, Conservation and Recycling*, 44(1):91 – 98, 2005.
- [74] J. Hopewell, R. Dvorak, and E. Kosior. Plastics recycling: challenges and opportunities. *Philosophical Transactions of the Royal Society B: Biological Sciences*, 364(1526):2115, 2009.
- [75] Esther Hu. The effect of machine and material parameters on rare earth roller separation. Bachelor’s thesis, Massachusetts Institute of Technology, Department of Mechanical Engineering, June 2009.
- [76] Jaco Huisman. *The QWERTY/EE Concept: Quantifying Recyclability and Eco-efficiency for End-of-Life Treatment of Consumer Electronic Products*. PhD dissertation, Delft University of Technology, Delft, The Netherlands, 2003.
- [77] D. G. Hulbert. The optimum distribution of cell capacities in flotation circuits. *Minerals Engineering*, 14(5):473 – 486, 2001.
- [78] K. Inada, R. Matsuda, C. Fujiwara, M. Nomura, T. Tamon, I. Nishihara, T. Takao, and T. Fujita. Identification of plastics by infrared absorption using InGaAsp laser diode. *Resources, Conservation and Recycling*, 12:31–48, 2001.
- [79] ISRI Scrap Specifications, Circular 2008: Guidelines for Nonferrous Scrap, Ferrous Scrap, Glass Cullet, Paper Stock, Plastic Scrap, Electronics Scrap, Tire Scrap. Published by Institute of Scrap Recycling Industries.

- [80] A. Jowett and D. N. Sutherland. Some theoretical aspects of optimizing complex mineral separation systems. *International Journal of Mineral Processing*, 14(2):85 – 109, 1985.
- [81] K. Kakudate, Y. Adachi, and T. Suzuki. A macro model for usage and recycling pattern of steel in Japan using the population balance model. *Science and Technology of Advanced Materials*, 1(2):105–116, 2000.
- [82] R. P. King. A computer programme for the simulation of the performance of a flotation plant. Technical Report 1436, South Africa National Institute of Metallurgy, 1973.
- [83] R. P. King. Simulation of flotation plants. *Trans. Soc. Min. Eng. AIME*, 258:286–293, 1975.
- [84] R. Peter King. *Modeling and Simulation of Mineral Processing Systems*. Butterworth-Heinemann, 2001.
- [85] J. Kirchner, G. Timmel, and G. Schubert. Comminution of metals in shredders with horizontally and vertically mounted rotors – microprocesses and parameters. *Powder Technology*, 105(1-3):274 – 281, 1999.
- [86] W. A. Knight and M. Sodhi. Design for bulk recycling: Analysis of materials separation. *Annals of the CIRP*, 49(1):83–86, 2000.
- [87] R. Köhnlechner, Z. Schlett, M. Lungu, and C. Caizer. A new wet eddy-current separator. *Resources, Conservation and Recycling*, 37:55–60, 2002.
- [88] A. Kulcke, C. Gurschler, G. Spock, R. Leitner, and M. Kraft. On-line classification of synthetic polymers using near infrared spectral imaging. *Journal of near infrared spectroscopy*, 11(1):71–81, 2003.
- [89] A.J.D. Lambert, H.M. Boelaarts, and M.A.M. Splinter. Optimal recycling system design: With an application to sophisticated packaging tools. *Environmental and Resource Economics*, 28:273–299, 2004.
- [90] David Laner and Helmut Rechberger. Treatment of cooling appliances: Interrelations between environmental protection, resource conservation, and recovery rates. *Resources, Conservation and Recycling*, 52(1):136 – 155, 2007.
- [91] N. C. Lee. *Practical Guide to Blow Moulding*. Smithers Rapra Technology, 2006.
- [92] P. Li, S. Guldborg, H.O. Riddervold, R. Kirchain, and H. Aluminum. Identifying economic and scrap reuse benefits of light metals sorting technologies. In *Proceedings EPD Congress*, pages 1159–1172, 2005.
- [93] Xianbing Liu, Masaru Tanaka, and Yasuhiro Matsui. Economic evaluation of optional recycling processes for waste electronic home appliances. *Journal of Cleaner Production*, 17(1):53 – 60, 2009.

- [94] ZK Liu. Effect of impurities on alloys. *IT Program. Washington, DC: Energy Efficiency and Renewable Energy US Department of Energy*, 2003.
- [95] Qin Lu, Julie Ann Stuart Williams, Marc Posner, Winston Bonawit-tan, and Xiuli Qu. Model-based analysis of capacity and service fees for electronics recyclers. *Journal of Manufacturing Systems*, 25(1):45–57, 2006.
- [96] G. H. Luttrell, J. N. Kohmuench, and M. J. Mankosa. Optimization of magnetic separator circuit configurations. *Journal of Minerals & Metallurgical Processing*, 21(3):153–157, August 2004.
- [97] M. Malaina, I.R. SA, M. Larrañaga, and F. GAIKER. D4: Analysis and Demonstration Activity for E&E Recycling. Technical Report TST3-CT-2003-506075, Sustainable Electrical & Electronic System for the Automotive Sector, 30 June 2006.
- [98] H. R. Manouchehri. Mapping and development of shredding product stream(s): Four shredding plants in sweden (what should be done for better performance of the plants?). Technical Report D 817, Jernkontorets Forskning and Northland Oretch Consulting Co., 30 June 2006.
- [99] H. R. Manouchehri. Looking at shredding plant configuration and its performance for developing shredding product stream (an overview). Technical Report D 823, Jernkontorets Forskning and Northland Oretch Consulting Co., 03 September 2007.
- [100] F De La Mantia. *Handbook of Plastics Recycling*. Smithers Rapra Technology, 2002.
- [101] Fabiano Maraspin, Paolo Bevilacqua, and Peter C. Rem. Modelling the throw of metals and nonmetals in eddy current separations. *International Journal of Mineral Processing*, 73:1–11, 2004.
- [102] Z.T. Mathe, M.C. Harris, C.T. O’Connor, and J-P. Franzidis. Review of froth modelling in steady state flotation systems. *Minerals Engineering*, 11(5):397 – 421, 1998.
- [103] Emily Matthews, Christof Amann, Stefan Bringezu, Marina Fischer-Kowalski, Walter Hüttler, René Kleijn, Yuichi Moriguchi, Christian Ottke, Eric Rodenburg, Don Rogich, Heinz Schandl, Helmut Schütz, Ester Van Der Voet, and Helga Weisz. *The Weight of Nations : Material Outflows from Industrial Economies*. World Resources Institute, 2000.
- [104] S. P. Mehrotra and P. C. Kapur. Optimal suboptimal synthesis and design of flotation circuits. *Separation Science*, 9:89–99, 1974.
- [105] Clarissa Morawski. Understanding economic and environmental impacts of single-stream collection systems. Technical report, Container Recycling Institute, December 2009.

- [106] J.A. Müller. Comminution of organic material. *Chemical Engineering & Technology*, 26(2):207–217, 2003.
- [107] J. Nakajima, H. Nakazawa, H. Sato, and Y. Kudo. Study on air separation of pvc and pet. *Journal of the Mining and Material Processing Institute of Japan*, 117:123 – 126, 2001.
- [108] 2009 report on post consumer PET container recycling activity. Final report, National Association for PET Container Resources (NAPCOR), 20 October 2010.
- [109] Tim Napier-Munn and Barry A. Wills. *Wills' Mineral Processing Technology, Seventh Edition: An Introduction to the Practical Aspects of Ore Treatment and Mineral Recovery*. Butterworth-Heinemann, 2006.
- [110] Yasuhiko Ogushi and Milind Kandlikar. Assessing extended producer responsibility laws in japan. *Environmental Science & Technology*, 41(13):4502–4508, 2007.
- [111] R. D. Pascoe. Sorting of waste plastics for recycling. Rapra Review Report 124, Rapra Technology Ltd., 2000. Volume 11, Number 4.
- [112] R. Plushnick-Masti. Recycling surges with high metal, fuel prices networks. Available online at <http://www.manufacturing.net/News-Recycling-Surges-With-High-Metal-Fuel-Prices.aspx>. Accessed April 19, 2011., 5 August 2008.
- [113] A. Porteous. Energy from waste incineration: a state of the art emissions review with an emphasis on public acceptability. *Friends of the Earth*, 12(308):128, 2001.
- [114] A. Porteous. Why energy from waste incineration is an essential component of environmentally responsible waste management. *Waste Management*, 25(4):451 – 459, 2005. 1st UK Conference and Exhibition on Biodegradable and Residual Waste Management.
- [115] Richard C. Porter. *The Economics of Waste*. RFF Press, 2002.
- [116] P. C. Rem, E. M. Beunder, and A. J. van den Akker. Simulation of eddy-current separators. *IEEE Transactions on Magnetics*, 34(4):2280–2286, July 1998.
- [117] P. C. Rem, P. A. Leest, and A. J. van den Akker. A model for eddy current separation. *International Journal of Mineral Processing*, 49:193–200, 1997.
- [118] M. A. Reuter and J. S. J. van Deventer. The use of linear programming in the optimal design of flotation circuits incorporating regrind mills. *International Journal of Mineral Processing*, 28:15–43, 1990.

- [119] Charles R. Rhyner, Leander J. Schwartz, Robert B. Wenger, and Mary G. Kohrell. *Waste Management and Resource Recovery*. CRC-Press, 1995.
- [120] C.M. Rose. *Design for environment: a method for formulating product end-of-life strategies*. PhD dissertation, Stanford University, Department of Mechanical Engineering, November 2000.
- [121] V.E. Ross. The behaviour of particles in flotation froths. *Minerals Engineering*, 4(7-11):959 – 974, 1991.
- [122] N. Sachs. Planning the funeral at the birth: extended producer responsibility in the European Union and the United States. *Harvard Environmental Law Review*, 30:51, 2006.
- [123] M. Saeki, T. Inoue, M. Tukahara, and H. Maehata. New separation technique for waste plastics. *Resource Recovery and Conservation*, 68:14 – 20, 2002.
- [124] K. Saitoh, I. Nagano, and S. Izumi. New separation technique for waste plastics. *Resource Recovery and Conservation*, 2:127 – 145, 1976.
- [125] S. Sander and G. Schubert. Size reduction of metals by means of swing-hammer shredders. *Chemical Engineering & Technology*, 26(4):409–415, 2003.
- [126] S. Sander, G. Schubert, and H.-G. Jäckel. The fundamentals of the comminution of metals in shredders of the swing-hammer type. *International Journal of Mineral Processing*, 74(Supplement 1):S385 – S393, 2004. Special Issue Supplement Comminution 2002.
- [127] Dan Sawyer. New avenues in recycling: NIR and other technologies sort PET and bioresin bottles. Technical report, Nature Works, LLC, 23 February 2009.
- [128] J. Scheirs and G. Camino. Effect of contamination on the recycling of polymers. In Francesco Paolo La Mantia, editor, *Recycling of PVC and Mixed Plastics Wastes*, pages 167–183. ChemTec Publishing, 1996.
- [129] A. J. Schmidt, M. R. Elmore, C. H. Delegard, and R. M. Nendick. Segregation of uranium metal from k basin sludge: Results from vendor testing. Technical Report PNNL-14845, Pacific Northwest National Laboratory, Pacific Northwest National Laboratory, Richland, Washington 99352, September 2004.
- [130] G. Schubert and S. Bernotat. Comminution of non-brittle materials. *International Journal of Mineral Processing*, 74(Supplement 1):S19 – S30, 2004. Special Issue Supplement Comminution 2002.
- [131] R. Schuhmann. Flotation kinetics. i. methods for steady-state study of flotation problems. *The Journal of Physical Chemistry*, 46(8):891–902, 1942.
- [132] Current spot market prices: Used beverage cans (ubc loose). <http://www.scrapindex.com/metal/usa/aluminum/index.html>. Accessed on June 1, 2005.

- [133] Current spot market prices: Scrap mixed irony aluminum. <http://www.scrapindex.com/metal/usa/aluminum/index.html>. Accessed on June 1, 2005.
- [134] Current spot market prices: Scrap low grade irony aluminum. <http://www.scrapindex.com/metal/usa/aluminum/index.html>. Accessed on June 1, 2005.
- [135] Current spot market prices: Light scrap copper. <http://www.scrapindex.com/metal/usa/copper/index.html>. Accessed on June 1, 2005.
- [136] Current spot market prices: No.2 copper wire scrap. <http://www.scrapindex.com/metal/usa/copper/index.html>. Accessed on June 1, 2005.
- [137] Current spot market prices: No.1 copper wire nodules. <http://www.scrapindex.com/metal/usa/copper/index.html>. Accessed on June 1, 2005.
- [138] Current spot market prices: No.2 copper wire nodules. <http://www.scrapindex.com/metal/usa/copper/index.html>. Accessed on June 1, 2005.
- [139] Current spot market prices: Scrap battery lugs. <http://www.scrapindex.com/metal/usa/lead/index.html>. Accessed on June 1, 2005.
- [140] Current spot market prices: Scrap irony magnesium. <http://www.scrapindex.com/metal/usa/magnesium/index.html>. Accessed on June 1, 2005.
- [141] Current spot market prices: Scrap block tin. <http://www.scrapindex.com/metal/usa/tin/index.html>. Accessed on June 1, 2005.
- [142] Current spot market prices: Scrap pewter. <http://www.scrapindex.com/metal/usa/tin/index.html>. Accessed on June 1, 2005.
- [143] Current spot market prices: Scrap high tin babitt. <http://www.scrapindex.com/metal/usa/tin/index.html>. Accessed on June 1, 2005.
- [144] Current spot market prices: Irony zinc scrap. <http://www.scrapindex.com/metal/usa/zinc/index.html>. Accessed on June 1, 2005.
- [145] Current spot market prices: Galinizers bottom dross. <http://www.scrapindex.com/metal/usa/zinc/index.html>. Accessed on June 1, 2005.
- [146] Current spot market prices: Zinc dross. <http://www.scrapindex.com/metal/usa/zinc/index.html>. Accessed on June 1, 2005.
- [147] Huiting Shent, R. J. Pugh, and E. Forssberg. A review of plastics waste recycling and the flotation of plastics. *Resources, Conservation and Recycling*, 25(2):85 – 109, 1999.

- [148] J. Shibata, S. Matsumoto, H. Yamamoto, E. Kusaka, and Pradip. Flotation separation of plastics using selective depressants. *International Journal of Mineral Processing*, 48:127 – 134, 1996.
- [149] J. Shimoizaka, A. Kounosu, and Y. Hayashi. Fundamental research on wet separation of waste plastics by combination of sinkfloat separation and flotation. *Journal of Mining and Metallurgical Institute of Japan*, 90:775 – 779, 1974.
- [150] J. Shimoizaka, A. Kounosu, Y. Hayashi, and K. Saito. A new type sinkfloat separator for waste plastics. *Journal of Mining and Metallurgical Institute of Japan*, 92:675 – 679, 1976.
- [151] M. S. Sodhi, J. Young, and W. A. Knight. Modelling material separation processes in bulk recycling. *International Journal of Production Research*, 37(10):2239–2253, 1999.
- [152] Magnetic drums. Available at <http://www.steinert.com.au/default.asp?contentID=519>. Accessed on May 23, 2011.
- [153] A. L. N. Stevels, A. A. P. Ram, and E. Deckers. Take-back of discarded consumer electronic products from the perspective of the producer: conditions for success. *Journal of Cleaner Production*, 7(5):383 – 389, 1999.
- [154] N. Sunthonpagasit and M. R. Duffey. Scrap tires to crumb rubber: feasibility analysis for processing facilities. *Resources, Conservation and Recycling*, 40:281–299, 2004.
- [155] T. Takeshita, T. Harada, S. Takeichi, and T. Saito. The continuous triboelectric separation for plastics sheets. *Journal of the Society of Powder Technology, Japan*, 37:594–597, 2000.
- [156] T. Tamon, S. Fujii, K. Inada, K. Motomura, I. Nishihara, and T. Fujita. A proposal of plastic sensing by infrared absorption using laser diode. In *Proceedings of the 16th SICE (The Society of Instrument and Control Engineering) Symposium on Sensing Forum*, pages 147–152, 1999.
- [157] N.J. Themelis. An overview of the global waste-to-energy industry. *Waste Management World*, pages 40–48, 2003.
- [158] G. Timmel, S. Sander, and G. Schubert. Comminution of scrap and metals in shredders with horizontally and vertically mounted rotor. In Paolo Massacci, editor, *Oral Session, Proceedings of the XXI International Mineral Processing Congress*, volume 13 of *Developments in Mineral Processing*, pages C12a – 1–C12a–8. Elsevier, 2000.
- [159] U.S. Geological Survey, 2004, aluminum statistics. In T. D. Kelly and G. R. Matos, editors, *Historical statistics for mineral and material commodities in the United States*, number 140 in U.S. Geological Survey Data Series.

- [160] U.S. Geological Survey, 2004, lead statistics. In T. D. Kelly and G. R. Matos, editors, *Historical statistics for mineral and material commodities in the United States*, number 140 in U.S. Geological Survey Data Series.
- [161] A. van Schaik, M. A. Reuter, U. M. J. Boin, and W. L. Dalmijn. Dynamic modelling and optimisation of the resource cycle of passenger vehicles. *Minerals Engineering*, 15:1001–1016, 2002.
- [162] A. van Schaik, M. A. Reuter, and K. Heiskanen. The influence of particle size reduction and liberation on the recycling rate of end-of-life vehicles. *Minerals Engineering*, 17:331–347, 2004.
- [163] Xuefeng Wen, Yuemin Zhao, Chenlong Duan, Xiaohua Zhou, Hongguang Jiao, and Shulei Song. Study on metals recovery from discarded printed circuit boards by physical methods. In *International Symposium on Electronics and the Environment*, New Orleans, LA, May 2005. IEEE.
- [164] M.C. Williams, D.W. Fuerstenau, and T.P. Meloy. Circuit analysis—general product equations for multifeed, multistage circuits containing variable selectivity functions. *International Journal of Mineral Processing*, 17(1-2):99 – 111, 1986.
- [165] M.C. Williams and T.P. Meloy. On the definition and separation of fundamental process functions. *International Journal of Mineral Processing*, 26(1-2):65 – 72, 1989.
- [166] Malima Isabelle Wolf, Marcello Colledani, Stanley B. Gershwin, and Timothy G. Gutowski. Modeling and design of multi-step separation systems. In *International Symposium on Sustainable Systems and Technology*, Washington D. C., 16-19 May 2010. IEEE.
- [167] E. T. Woodburn, H. W. Kropholler, J. C. A. Green, and L. A. Cramer. *The utility and limitations of mathematical modelling in the prediction of the properties of flotation networks.*, volume A.M. Gaudin Memorial Volume, Vol. 2 of *Flotation*, chapter 24. American Institute of Mining, Metallurgical and Petroleum Engineers, New York, N.Y., 1976.
- [168] Chuanfu Xiao, Laurence Allen III, and Michael B. Biddle. Electrostatic separation and recovery of mixed plastics. In *Annual Recycling Conference Proceedings*, Detroit, MI, 9-11 November 1999. Society of Plastics Engineers.
- [169] Jon C. Yingling. Circuit analysis: optimizing mineral processing flowsheet layouts and steady state control specifications. *International Journal of Mineral Processing*, 29(3-4):149 – 174, 1990.
- [170] Jon C. Yingling. Parameter and configuration optimization of flotation circuits, part i. a review of prior work. *International Journal of Mineral Processing*, 38(1-2):21 – 40, 1993.



- [171] Shunli Zhang and Eric Forsberg. Optimization of electrodynamic separation for metals recovery from electronic scrap. *Resources, Conservation and Recycling*, 22:143–162, 1998.
- [172] Shunli Zhang, Eric Forsberg, Bo Arvidson, and William Moss. Aluminum recovery from electronic scrap by high-force eddy-current separators. *Resources, Conservation and Recycling*, 23:225–241, 1998.
- [173] Shunli Zhang, Eric Forsberg, Bo Arvidson, and William Moss. Separation mechanisms and criteria of a rotating eddy-current separator operation. *Resources, Conservation and Recycling*, 25:215–232, 1999.