

EFFECTS OF SEAPORT TRADE
ON
METROPOLITAN COMMERCIAL REAL ESTATE
WITH A CONCENTRATION ON THE PORT OF MIAMI

by

WILLIAM P. THOMPSON

Master of Business Administration
University of Miami
(1986)

B.A. Business Administration
Slippery Rock University
(1977)

SUBMITTED TO THE DEPARTMENT OF
ARCHITECTURE
IN PARTIAL FULFILLMENT OF THE REQUIREMENTS
FOR THE DEGREE OF
MASTERS OF SCIENCE IN REAL ESTATE DEVELOPMENT
AT THE
MASSACHUSETTS INSTITUTE OF TECHNOLOGY

September, 1990

© - William P. Thompson, 1990.

The author hereby grants to MIT permission to reproduce and to distribute copies of this thesis document in whole or in part.

Signature of Author _____

William P. Thompson
Department of Architecture
July, 1990

Certified by _____

Ernst G. Frankel
Professor, Ocean Engineering
Thesis Supervisor

Accepted by _____

Gloria Schuck
Chairperson

Interdepartmental Degree Program in Real Estate Development

MASSACHUSETTS INSTITUTE
OF TECHNOLOGY

SEP 19 1990

LIBRARIES
Rotch

**EFFECTS OF SEAPORT TRADE
ON
METROPOLITAN COMMERCIAL REAL ESTATE
WITH A CONCENTRATION ON THE PORT OF MIAMI**

by

WILLIAM P. THOMPSON

**Submitted to the Department of
Architecture
In Partial Fulfillment of the Requirements
For the Degree of
Masters of Science In Real Estate Development**

ABSTRACT

Seaports are a vital trade link in a growing international economy. They act as a gateway for 82% of total world trade. Depending on a port's efficiency and capacity, it drives the economic growth of the metropolitan area or region it serves. The United States is a good example. Virtually all of the country's major cities evolved from the commerce in and around the major seaports.

The impact of seaport activities, then, generates a substantial amount of jobs, income and wealth. This, in turn, creates considerable demand for office and industrial space. For example, importers and exporters require a significant amount of storage space for cargo. Cruise line companies demand a notable amount of office and warehouse space to support their operations. The chain of businesses supporting cargo and cruise industries is extensive. Thus, an increase in cargo volume or cruise passengers has a tremendous ripple affect throughout this support chain. Accordingly, each of these activities need either office or industrial space to work.

This thesis identifies and analyzes the factors that shape the demand for commercial real estate relative to seaport activities. First, seaports are discussed within the context of regional and local economics. Next, seaport activities are presented within a cause and effect relationship to demonstrate the complex sequence of businesses. Finally, the type of work space required by these businesses are identified. In addition, future implications are suggested along with recommendations for subsequent study of the effects of seaports on the demand for commercial real estate.

Thesis Supervisor: Dr. Ernst G. Frankel
Professor,
Department Of Ocean Engineering

A mi esposa
por todo el apoyo
que me ha dado
en mis esfuerzos
para poder alcanzar mis sueños

TABLE OF CONTENTS

Schedule of Exhibits 5
Chapter 1: Introduction 6
Chapter 2: Regional Economics and the Port Industry11
Chapter 3: Understanding the Seaport Industry27
Chapter 4: Linking the Seaport to Commercial Real Estate...36
Chapter 5: Summary, Conclusions and Future Implications....78
Selected Bibliography87

SCHEDULE OF EXHIBITS

Chapter 2

Exhibit 2.1	Regional Economic Growth Model.....	16
Exhibit 2.2	Economic Impact Model for Seaports.....	19

Chapter 3

Exhibit 3.1	Cargo Container Examples.....	92
Exhibit 3.2	Container Ships at the Port of Miami.....	93
Exhibit 3.3	Ro-Ro Cargo at the Port of Miami.....	94

Chapter 4

Exhibit 4.1	Port of Miami Economic Impact Calculations..	91
Exhibit 4.2	Cruise Industry Flow Chart.....	49
Exhibit 4.3	Cruise Industry Matrix for Real Estate Uses.	51
Exhibit 4.4	Cargo Industry Flow Chart.....	58
Exhibit 4.5	Cargo Industry Matrix for Real Estate Uses..	61

Chapter 5

Exhibit 5.1	Port Industry Survey.....	90
-------------	---------------------------	----

CHAPTER ONE INTRODUCTION

From ancient times seaports have been important factors in the economic development of civilizations through the exchange of new ideas, cultures and commerce. The United States provides a good example of this process. Virtually every major city in this country evolved from a seaport. For example, New York, Boston, Chicago and Los Angeles all evolved into major economic bases through international commerce at their seaports. Seaports have also played a vital role in America's national defense during both World Wars. After the Wars, America's seaports played a vital role in post war shipments to war-torn Europe.

Many trade and economic experts consider seaports to be crucial "economic engines" of metropolitan areas (the local area and suburbs surrounding a seaport) and many times of entire regions (a geographic area represented by one or more states). Consider these facts. Over 82% of world trade tonnage is moved by shipping. Also, seaport investment worldwide is in excess of \$12 billion. (Frankel, 1987, page 1-2). Hence, a significant portion of world trade moves through seaports, providing a considerable amount of jobs, income and wealth.

The Maritime Administration, recognizing the importance of sea ports, authorized a detailed study of the U.S. Port Industry in 1987. The study indicated that the port industry, indeed, has a significant impact on the national economy (U.S. Department of Commerce, 1978). The information in this study prompted the Maritime Administration to establish a national and regional economic impact (input-output) model, that is available to all U.S. Ports. Since then, several independent firms have evolved variations of this model that have further established the economic importance of a seaport, particularly at a regional and local level.

Seaport efficiency, capacity, and interior transportation system are important factors in determining how much trade a particular port captures. Dr. Frankel, a prominent port and international trade scholar, notes that the status of a seaport system can determine the growth and economic potential of the region or country they serve.

Hypothesis:

In the writers opinion, the success of the United States economy during the twentieth century will depend upon its competitiveness in the international trade arena. If seaports are the gateway for 82% of international trade; and if seaport capacity and efficiency determine the growth and economic

potential of the region or country they serve, then the level of trade through a seaport will substantially determine the economic prosperity of a metropolitan area and region surrounding the seaport. Because economic growth is a major determinant for demand for real estate in a metropolitan area, then the author's hypothesis is that seaports must also have a considerable effect on commercial real estate in a metropolitan area. Accordingly, the primary objective of this thesis is to establish the link between trade, the seaport and real estate, as well as, establish a working framework for determining the effects of seaport activities on the demand for commercial real estate in a metropolitan area. To provide a clearer understanding of the connection between ocean borne trade and commercial real estate, the Port of Miami and the Miami metropolitan area are used as examples throughout this writing. Readers must keep in mind that this study does not attempt to quantify the demand effects. Rather, it attempts to define the logic as a basis for future work in this area.

In order to support the argument that seaports have a substantial impact on commercial real estate in a metropolitan area, this writing is presented in four sections. Chapter two provides a basic foundation for regional and metropolitan economics. It includes information on the Florida economy as "the region" and the Miami standard metropolitan statistical area (SMSA) as "the metropolitan area" to familiarize the

reader on the basic trade activities that occur in the area. Chapter three addresses the cargo types and port operations of the port industry. Chapter four establishes the general framework and logic to determine the effects of interregional and international trade on a metropolitan area, specifically Miami, Florida. Finally, chapter five brings forth several a summary of the seaport and its effect on real estate, some possible future implications, data deficiencies in this study, and a recommendation of how future study in this area should proceed.

Questions To Answer:

- 1) What are the relative economic implications of ocean borne trade on a metropolitan area? Is a seaport a significant "economic engine" of a metro area?
- 2) How do seaport activities and ocean borne cargo foster real estate demand in a metropolitan area?
- 3) Do trade types and seaport facilities dictate different demands on real estate?
- 4) What future trade indicators might lead to increased demand for either office or industrial space?

References and Information:

The regional economic theory used in this study is based primarily on articles, research and lectures by William Wheaton, Professor in the Department of Economics and Urban Studies and Planning at Massachusetts Institute of Technology. A condensed version of this theory is presented in chapter two. Economic impact analysis is also discussed in chapter two. Available research in this area is extensive. The sources used herein are based on recommendation from Karen R. Polenske, a professor of Urban Studies and Planning, also at MIT. In the area of ocean borne trade and seaports, information is extensive. The author has attempted to use the most relevant information available.

Information relative to how seaport activities effect demand for commercial real estate in a metropolitan area, however, is extremely limited. The cause and effect relationships between the seaport and commercial real estate and the general framework and to determine demand for this real estate, is primarily the work of the author and his advisor. Support of this section was established through personal or telephone interviews with several cruise and cargo related activities. These sources offered invaluable support for establishing the link between seaport activities and real estate.

CHAPTER TWO
REGIONAL ECONOMICS AND THE SEAPORT INDUSTRY

Regional Economics is a relative young field of study that has been steadily evolving over the past two decades. An understanding of this evolution and current thought is most important to fully comprehend the effects of regional economics on a seaport and vice-a-versa. Moreover, a thorough understanding of regional economics will provide insight into future demand effects of seaport activity on commercial real estate in a metro area. Accordingly, the first part of this chapter attempts to identify and summarize the factors that drive a regional and local economy, as well as demonstrate how these factors affect a local seaport. The second part of chapter two addresses the most important economic impact methodologies for analyzing a regional and local economy. How these methods can be used to analyze the relationship between seaport trade and metro commercial real estate is also presented.

EVOLUTION OF REGIONAL ECONOMIC THEORY:

The majority of economic ideas presented below were summarized from the book titled Interregional Movements and Regional Growth and edited by William Wheaton (see the bibliography section). Historically, the study of regional economics has been focused on techniques and methodologies that are useful in planning regional development. John Meyer (1963) described

four theoretical foundations of regional science: location theory, multiplier analysis, input-output analysis and programming models. According to Richardson in 1960, the treatment of regional growth, however, generally consisted of a small set of hypotheses and ideas borrowed mainly from Keynesian or international trade theory. North in 1955 and Perloff in 1963 noted that according to the Keynesian theory, economic growth and decline follows from shifts in the demand for a regions product. Accordingly, changes in product demand create new factor demand, and assuming largely inelastic supplies, factor payments respond quite quickly. Hence, under this approach employment growth is accompanied by rising wages and low unemployment or high capacity utilization. Employment decline, on the other hand, results in slack market conditions with high unemployment or idle capacity and factor payments. It should be pointed out, however, that both of these approaches lack sufficient data to support the theories (Wheaton, 1979, page 6).

While early theory stressed the importance of a region's natural resources or other exogenous sources of product demand, research, which has emerged during the 15 years since Meyer's survey, suggests there are other important factors. For example, there is growing support for the notion that maybe the most import resources of a region are its work-force and the existing industrial structure (e.g., a seaport and its

labor force). This has led to three important concepts in regional economics:

- * Migration may lead rather than follow the industrialization of a region.
- * Urban scale and the presence of complementary industries are important determinants of regional growth.
- * Mobility of a region's labor force is as important as natural resources in determining regional growth.
- * Transportation costs play a relatively minor role, while wages, labor availability, business taxes and space are the dominant forces behind most industrial location

Research on Migration: In regard to the work-force, Borts (1960), Kuznets (1964), Muth (1971), Steinnes (1978), and Greenwood (1975) advanced the notion that migration may lead rather than follow the industrialization of a region, because it provides both a pool of labor and a ready market for output. Borts and Stein (1960) followed this idea with research that examined the differences between growth in the Northern United States versus growth in the Southern United

States and concluded that migration preferences had as much to do with regional growth as shifts in demand (Wheaton, 1979, page 238). Wheaton tested this theory with a simple cross sectional analysis of interregional differences in growth, unemployment and wages. He found that wages have limited statistical association with regional employment growth. In essence, Wheaton's study indicates that population movements appear to be as important to long run economic growth or decline, as changes in industrial demand. Hence, this research supports the notion that migration may lead rather than follow the industrialization of a region, because it provides both the labor and a ready market for output.

Optimal City Size: Chinitz (1961), Berry (1967) and Poor (1973) argue that the presence of complementary industries and urban scale are also important determinants of regional growth. Alonso (1971), Mera (1973), and Richardson (1972) argue that the existing industrial structure provided by large cities are precisely the resources necessary for regional growth (Wheaton, 1979, pages 6-7).

Research on Regional Product Demands: Another trend in regional economic theory suggest that regional product demands can be quite inelastic, and that demand immobility is the prime impediment to regional growth. This differs substantially from the earlier view that regional resources

are the main impediment to growth (Wheaton, 1976, page 7). Neo-Keynesian models of Adam et. al. (1975), Engle (1974) and Friedlander, Treys, and Treach (1975) departed from the traditional assumptions that interregional differences in product prices should reflect only transportation costs (Wheaton, 1976, page 7). All these models indicate that even in the medium run, regional product demands can be quite inelastic. Thus, labor availability and skill is as important as natural resources in attracting activities to a region.

Research on Transportation Costs: Finally, there is a new theory on the impact of transportation costs on regional growth. It deals with how interregional factor markets behave. Traditional theory (according to Moses in 1958, Sakashitai in 1968 and Koopmans in 1957) suggest that the prime determinant of spatial profits can only be transportation costs (Wheaton, 1979, page 8). However, empirical research over the past 25 years challenges this theory. Researchers, such as, Due in 1961, Schmenner in 1975 and Struyk in 1975, provide descriptive and econometric methods to the study of actual firm behavior. The results of this empirical research consistently demonstrate that transportation costs play a relatively minor role, while wages, labor availability, business taxes and space are the dominant forces behind most industrial location (Wheaton, 1976, page 8).

CURRENT REGIONAL ECONOMIC THEORY

Through a combination of the findings just described, a more comprehensive approach to regional growth is presented below. The author, although not a scholar in the field of economics, considers this comprehensive approach the most current theory in understanding regional economic growth. One component of the study herein, (understanding how a seaport interacts with a regional and metropolitan economy) is based on this theory.

In essence, this approach to regional economics suggest that regional growth can be driven as much by "product demand" as it can be from "factor supply". In contrast, traditional theory focused primarily on product demand, suggesting that only a regions natural resources and exogenous sources determine regional growth. Exhibit 2.1 below illustrates the components of product demand and factor supply.

Exhibit 2.1

GENERALIZED MODEL FOR REGIONAL ECONOMICS

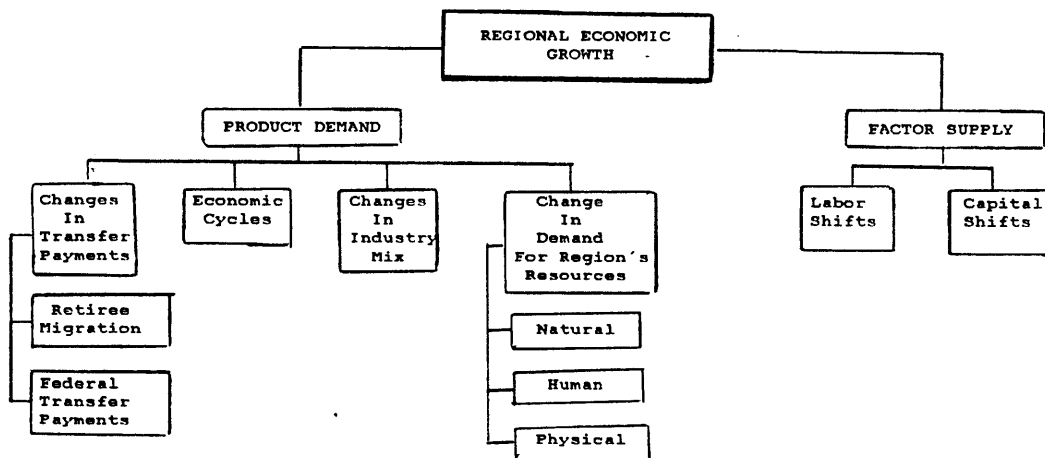

As demonstrated in Exhibit 2.1, product demand occurs due to autonomous migration such as retirees, shifts in federal transfer of payments, changes in the industry mix, recession, or changes in demand for a region's resources (natural, human and physical). A strategically located efficient seaport is a good example of the latter.

Factor supply on the other hand is stimulated by shifts in labor, capital, and foreign investment. Labor shifts may occur due to climate, immigration, increased fertility rate, (to the extent that it increases the labor force), increased labor participation, or perceived higher quality of living. Capital shifts may occur due to higher taxation or some other higher production cost in one region verses another. Foreign investment shifts may occur due to "flight capital" or higher investment returns in a particular region compared to the home country.

In terms of the full economic cycle, population increases impact local consumption of products and services, which in turn, place demands on the labor supply and product demand. The full cycle determines wages, production costs, regional business investment and further exogenous (labor) migration.

Impact of Regional Growth on Seaports:

Changes in either a region's product demand or factor supply can dramatically affect trade activities at a seaport.

Basically, current regional economic theory suggest that the type of shifts (e.g., labor, capital or retirees) determine if a region receives more imports or exports.

Florida, for example, has been driven primarily by retiree migration for the past 20 years, which resulted in a transfer of wealth and increased regional consumption. Thus, Florida was primarily a market driven by product demand. As a result, imports increased significantly through the region's seaport (particularly the Port of Miami). The state has now evolved to a region that is somewhat balanced between product demand and factor supply. Retirees are still migrating to the state. However, Florida is also benefitting from labor migration and capital shifts. This, in turn, is attracting more domestic and foreign business investment. Presently, the region's seaports are showing promising increases in both imports and exports.

If there is more than one seaport located in a region, then product demand begins to work at the local level. The seaport with a competitive advantage (i.e., strategic location, efficiencies, available capacity, etc. will attract the major share of both imports an exports for the region.

Exhibit 2.1 below illustrates the cause and effect relationship between a seaport and a regional economy by dividing port activity into cargo that affects imports and cargo that affects exports.

Exhibit 2.2

SEAPORT TRADE AND ACTIVITIES MODEL

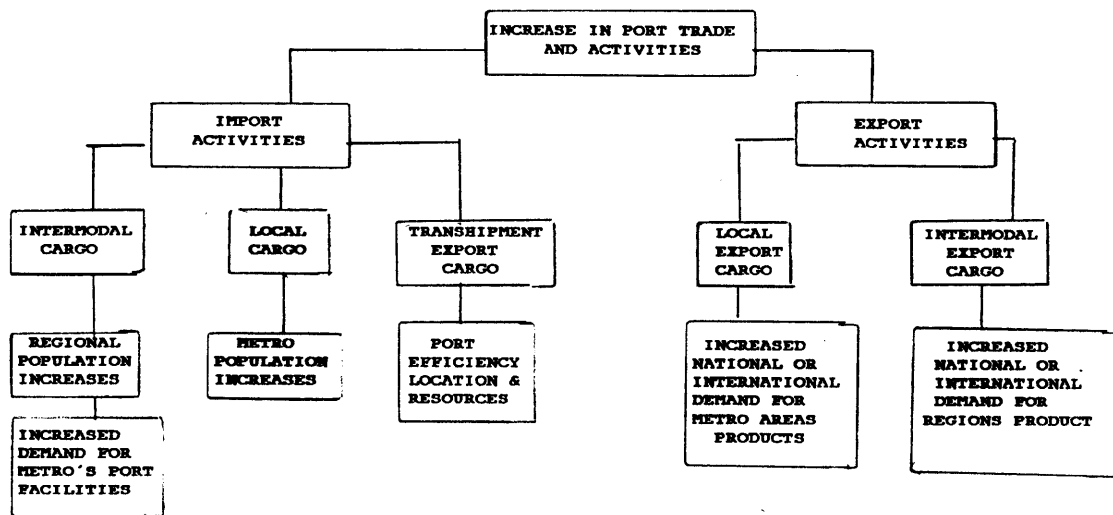

The Port of Miami's competitive edge, for example, is its strategic location, a highly developed import/export industry, and a quality container cargo transport industry. Initially (in the 1970's), the Port of Miami benefited from its proximity to south Florida (a high population growth area stretching three counties from Miami to West Palm Beach). The majority of ocean borne imports destined for this tri-county area arrived through the Port of Miami. This offered the Port of Miami time to develop its cargo handling facilities and

create a critical mass of importers, exporters, freight facilitators and labor force for cargo handling.

In some instances, a well located efficient seaport will attract goods for export from areas outside the immediate region. This is a case of product demand at work; i.e., increased demand for a region's physical and human resources, (the port). An example of this situation is the Port of Miami. Consumption for products from the United States has been increasing in Latin America. This consumption has resulted in a significant increase in export activity through the Port of Miami. Some of the export activity is from within the region. However, a growing portion of exports, from outside the state, are being shipped via rail and truck to Miami for export to Latin American.

The Port of Miami is also receiving an increasing amount of transshipment business. It seems that Miami has attracted the majority of feeder vessels that sail to Latin America. In addition, the metropolitan area has developed a large contingency of freight forwarders, shipping agents and other business that can facilitate the movement of container cargo to Latin America. Also, the Port of Miami has recently added three large gantry cranes for a total of six, which enable the port to offer fast turn around time for ships. As a result, large foreign cargo vessels, which have products destined for

Latin America, but are too massive for docking and handling at Latin American ports, are choosing Miami as a transshipment point. All this combines to increase demand for the Port of Miami and the cargo handling structure in Metropolitan Miami.

Commercial Real estate demand created by this seaport activity depends heavily on the efficiency of the regions transportation system and the cost of storage space. For example, a region that can transport goods quickly will require less storage space because products move quickly from manufacture to consumer. In contrast, if storage space is relatively inexpensive, then imports will not be as concerned with the cost to store goods for local consumption.

ECONOMIC IMPACT METHODOLOGIES

Relative to analyzing the demand impact of seaport activities on commercial real estate in a metropolitan area it is essential to study each of the various business sectors and determine how these business sectors interact with the structural components of the economy. Once the economy is disaggregated and structural constraints defined, the relationship between waterborne trade and commercial real estate can be determined. With this in mind, there are three basic methodologies for studying regional economies: (i) economic base theory, (ii) econometric modeling, and (iii) input/output analysis.

Economic Base Theory:

With this method, the regional economy is categorized into two distinct sectors. The basic or 'export' region produces goods and services for consumption outside the region, while the non-basic or 'local' region produces goods and services for local or regional use. The local region is treated as a subset of the basic region, where movements in the basic region would have similar impacts on the local region. This model is appropriate for estimating short-run fluctuations that primarily occur within one year. The major advantage of this model is its simplicity. Data is readily available from the U.S. Department of Commerce, Bureau of the Census (County Business Patterns), and the Bureau of Economic Analysis (Local Area Personal Income). The major disadvantage of this model is that it assumes an over-simplification of a regional economy, such as, the relationship between demographic functions, technology, population and productivity. This method would not be very effective for the purpose of establishing space requirements for seaport activities, because it does not provide a good framework to disaggregate the economy with enough detail to determine employment and space needs for different businesses.

Econometric Modeling:

This type of economic modeling is based on the implementation

and measurement of various relationships within the system. Keynesian theory is relied upon, where national income is comprised of consumption, investment, fiscal spending and trade. Economic equations are designed to estimate economic effects of variation in income, employment and output through the use of time series data. As a result, econometric models can be much more accurate than economic base multipliers if the formulas within the model are appropriate. However, the formulas are usually proprietary information so the user can not access the reliability of the model. Also, it is difficult to perform a sectorial disaggregation of the regional economy. Thus, this method would prove demanding to use in determining the effects of seaport activity on commercial real estate in a metro area. However, if the structural relationships could be determined, than this method has the potential to provide an effective model for determining commercial real estate demand generated from seaport activities.

Noted econometric models include the Harris MRMI Model, the Multiregion Model, the NRIES Model and the Chase Econometric Model. The Chase model is probably the most widely used and considered to be very reliable in forecasting.

Input-Output Analysis:

The input-output model, in essence, provides a technique to

dissaggregate a local or regional economy. A unique matrix is provided by this model for arraying, processing and analyzing data in order to better understand the interindustry structure of the regional economy and the implications of the interdependence that prevails. In other words, the model consists of a matrix which can quantify employment by business sector. The level of detail is unlimited. In addition, the matrix can be developed one step further to determine space needs for each business that works with the seaport.

Input-output models have a distinctive advantage over economic base and econometric techniques. Its biggest advantage is the ability to show the interaction between seller and buyer industries before reaching the final consumer; i.e., the Input-Output model captures intermediate sales. Also, the Input-Output model provides details in terms of dollars that sales and purchases have on the economy. This technique appears to work well at the national and regional level.

There are several conceptual drawbacks of the input-output model. First, the time horizon is very short; i.e., the model provides only a snap-shot in time versus the time series capability of the econometric model. Second, this model does not have an empirical base. It does not build a structural relationship between historical economic impacts in the region and the activities and commerce that occur at the port.

Third, the model makes a static assumption of regional production technology. Direct input requirements for each industry are calculated based on technology in those industries remaining constant for periods of 5 to 15 years. This is not the situation in most developed regional economies. Finally, the typical size of such models (a matrix of a 500 X 500 variables) creates problems because the number of coefficients to be determined is substantial. This increases the possibility of error and the level of skill to complete the model.

Port Kit: The Port Kit Model, which uses a 32 X 32 sector matrix, is a simple version of the larger input-output model described above. It is a good simple model for analyzing the impact of seaport activities on metro commercial real estate. The model was prepared for the Maritime Administration by Arthur D. Little, Inc. It was developed specifically for the Maritime Administration to assist regional analysts, planners and port authorities in determining the economic impact of seaports at a regional and local level.

The most recent version consists of a 32 X 32 sector model (30 industries plus Federal and State/local governments). The model has been calibrated to provide results similar to the large scale RSRI 500 X 500 sector input-output model to produce approximately the same indirect and induced impacts

and input-output multipliers as the RSRI model. It is designed to be used with a survey based study or an estimation based study.

CHAPTER THREE UNDERSTANDING THE SEAPORT INDUSTRY

SEAPORT INDUSTRY OVERVIEW:

This chapter provides the reader with a fundamental overview of the seaport industry, and how it relates to trade activity within a metropolitan and/or regional economy. Specifically, this chapter identifies seaport and cargo terminology, seaport services and activities, cargo types, and the industries that either (i) rely on the seaport for the import or export of goods, or (ii) assist in the transfer of cargo.

The traditional role of a seaport is changing. In the past ports were established based on accessibility of a safe harbor and location. Issues such as highway systems, rail capacity and final destination of goods were not important. Today the design and location of seaports is based not only on the needs of ocean transport, but on the integration of the seaport subsystem as part of a complex inter-modal transportation and distribution system.

The primary function of a seaport is to provide cost efficient transfer, inspection, storage, and control of cargo and passengers. In response to this, the industry is demanding that seaport keep pace with the technological improvements in marine transportation and cargo handling, improved terminal design, and more effective techniques in storage utilization.

Specifically, seaports must establish deeper drafts, and provide facilities for special types of carriers to be competitive in the twentieth century (Frankel, 1987, page 8). Seaports which meet these new demands will generate improved turnaround time for ships and enhance the distribution of cargo, attracting more trade. This increase in cargo volume or passenger volume will, in turn, generate increased demand for commercial real estate in a metropolitan area.

DEFINING THE SEAPORT INDUSTRY:

There seems to be several definitions of the port industry. The discrepancy in definitions is probably due to the many activities involved with a port, and the significant differences in cargo and hinterland that may exist from port to port. In a study prepared for the Maritime Administration (U.S. Department of Commerce, 1978, page 17), the port industry is defined as:

The port industry is any economic activity that is directly needed in the movement of waterborne cargo.

In essence, the Maritime Administration considers any activity that is generated in conjunction with the direct provision of waterborne services (including activities that take place beyond the piers) as part of the port industry. For example, cargo documentation, cargo insurance, banking, land-feeder

services and water carriage are considered part of the port industry by the Maritime Administration. In contrast, activities such as exporting, suppliers of ship repair services and port machinery are not considered part of the port industry under the Maritime Administration's definition. These latter activities, in their opinion, do not have a direct impact on the economy. However, for the purposes of this study, activities such as importing and exporting are considered part of the port industry.

Specifically, the definition for this study is refined to include all activities and services as follows:

- (A) Any industry that uses the seaport to transport cargo; i.e., importers, exporters and freight consolidators, including intermodal shipment and transshipment of cargo.
- (B) Industries that provide seaport services or supplies to vessels; i.e., stevedores and ship chandlers (marine suppliers and food suppliers).
- (C) Off-port industries that directly support or assist in the movement of cargo; i.e., freight forwarders, shipping agents, shipping lines and custom brokers.
- (D) Professional services that support the movement of cargo

and ships through the seaport or assist in the operations of the cargo industry; i.e., banking, insurance, government agencies, consulting, advertising, marketing, and accounting.

- (E) All business that are involved with the cruise ship industry; i.e., cruise ship companies, food suppliers, beverage suppliers, material suppliers, as well as, banking, insurance, legal services, marketing, advertising, and accounting.

For more detail, refer to Exhibits 4.2 and 4.4 for detailed flow charts of the activities and services that are considered part of the cruise and cargo industry in this study.

CARGO TYPES, TERMINOLOGY AND HANDLING:

The type, volume, transfer methods and destination of cargo has a significant effect on demand for commercial real estate in a metropolitan area. Hence, it is critical to have a thorough understanding of the industry and trade activities in the metropolitan area under study. This section will focus these areas.

Waterborne cargo is generally referred to in one of three categories:

- * Bulk Cargo
- * Break-Bulk Cargo
- * Containerized Cargo

Bulk Cargo:

Bulk cargos are free flowing, dry or liquid, commodities moving in large homogeneous loads (Yochum and Agarwal, 1989, page 18). Bulk cargo is unique to other types of cargo because it is loaded and unloaded in a continuous operation with no discrete units (Little, 1979, page 116).

Bulk cargo is becoming increasingly important as noted by the expanding percentage of world seaborne trade moved in bulk (Frankel, 1987, page 500). The ocean transfer of bulk cargo has increased for several reasons. First, improved and specialized ship design allows larger bulk cargo loads and faster more efficient cargo transfer. In turn, terminal facilities have developed to a level that can handel these new ships (Frankel, 1987, page 500). Secondly, the improved efficiency and transfer time of bulk cargo has generated more demand for this type of cargo shipment. For example, many commodities that previously may have been processed and then shipped to the world markets, are now shipped in raw form to local markets for processing. Finally, there has been

increased global demand for liquid commodities (particularly petroleum), which has caused an overall demand increase in the transfer of bulk cargo.

Examples of liquid bulk cargo include petroleum, solvents, chemicals, milk, wine and fruit juices. These products have different transfer, processing and storage requirements than dry bulk cargo. They are usually unloaded by pumping at pressures of 10,000 tons per hour. This discharge can be remotely or automatically controlled and often is computer planned for the most optimum control of flow rate and loading sequence (Frankel, 1987, page 500).

Dry bulk cargo is represented by coal, grain, fertilizers, gypsum and ores. Loading of dry bulk products is typically done by shore based facilities and unloading is by either shore or ship-mounted equipment such as conveyors, boom and hoppers, cranes, scraper systems, bucket wheel systems, etc. Major developments in the handling of dry bulk cargo include larger and higher capacity equipment, higher density throughput and self unloading bulk carriers.

Because cargo transfer methods attempt to maximize continuity of flow, bulk cargo allows for more efficient transport and transfer than break-bulk cargo and containerized. Larger volume can be transported and faster transfer can be achieved

with bulk cargo. Liquid bulk cargo, such as petroleum, can be particularly efficient. For example, seaports which specialize in the handling of crude petroleum such as Port of New Orleans, Port of Houston and Port Everglades have refineries located directly at the port. Thus, ships can transport the liquid continuously and efficiently from the ship to the processing plant. It should be noted, however, that many types of cargo can not be transported in bulk. In addition, some seaports either are not equipped to efficiently handle bulk cargo or are prohibited from servicing bulk cargo. The Port of Miami is a good example of the latter. Due to the port's location in the Biscayne Aquifer, it is prohibited from handling bulk cargo. (The Biscayne Aquifer is an environmentally sensitive area.)

Break-Bulk Cargo:

Historically, break-bulk cargo was the most common form of cargo transport. Goods were packed in bags or cartons and loaded and unloaded by hand. In an effort to improve transport efficiency, reduce damage and eliminate pilferage, the majority of break-bulk cargo was diverted to either bulk or containerized cargo transport. Today, break-bulk cargo is a catch all-category for cargo not shipped in bulk or containers. Some cargo such as lumber, heavy equipment and autos, can not be converted into bulk or packed into containers and must be transported in break-bulk.

Containerized Cargo:

Cargo which can not be transfer in bulk and can more easily packed in standardized metal boxes is shipped via containers verses break-bulk. Examples of the most common containerized cargo include electronic equipment, apparel/finished textiles, floor and ceiling tile, stone, glass and pottery products.

There are two basic types of containers. The first type is a standardized metal container measuring 8' x 8' x 20' or 8 x 8' x 40' (see Exhibits 3.1 and 3.2). The second type is basically a truck trailer that is loaded into the hull of a ship. The cargo is essentially rolled-on and rolled-off, hence the name Ro-Ro cargo (see Exhibit 3.3). Standardized containers are usually a more efficient method of transporting cargo if the origin and destination ports have the facilities to effectively load and unload the containers. Ro-Ro cargo, on the other hand, is more efficient for short sailing distances (Miami to the Caribbean) to ports which do not have the container handling facilities or these facilities are congested.

SEAPORT OPERATIONS

There are numerous activities related to port operations. In summary these activities include carriers, handlers, documenters and financiers of cargo, which can be divided into four local/content classifications: water-front, inland,

general and special operations (Frankel, 1987, page 494).

Water front operations consist of navigation, accommodation, cargo transfer (stevedores), service, maintenance and marine administration of ships. In-land operations are involved with cargo storage (importers and exporters) and processing, interfacing transportation modes (freight forwarders), and traffic control (scheduling and routing). Short and long term accommodations of passenger is also considered part of inland operations, however, it will not be discussed in this study. General operations includes safety and environmental control (government agencies), port operation control (port management), port maintenance (dredging and repairs), and security. Special operations are essentially military operations and most functions mentioned above must be duplicated.

CHAPTER 4
LINKING SEAPORT TRADE TO COMMERCIAL REAL ESTATE

INTRODUCTION

This chapter, in essence, attempts to establish a framework by which the type and demand for commercial real estate can be linked to businesses and activities involved with a seaport. Structurally the chapter is divided into six parts.

First, the importance of a seaport in terms of its economic impact on a community is substantiated. The second section establishes a working definition of commercial real estate within the context of this study. The next segment is devoted to storage/warehousing - how much space is enough. The fourth section on the cruise industry, and the fifth section on the containerized cargo industry, are by far the most important. Both of these sections discuss (i) the businesses and activities directly connected to cruise and cargo industry, (ii) the cause and effect relationships between the significant business components and their demand for real estate, (iii) the types of real estate these businesses need, and (iv) the various economic and market factors that dictate the amount of space these firms require. Specialized storage, plus manufacturing and processing facilities for bulk and break-bulk cargo facilities are presented in the sixth segment of this chapter. Finally, all this information is summarized at the end of the chapter. The Port of Miami and the Miami

metropolitan area are used frequently as examples to help establish the various links and demand. Most of the information for this chapter was obtained through interviews and conversations with a variety of seaport related business and specialists, many of which are located in the Miami metro.

IMPORTANCE OF A SEAPORT

Seaports serve as an essential integrated link in a transport system designed to move cargo from origin to destination. In this process, seaports serve as transfer, storage, and distribution or collection centers for containerized cargo. They also serves as processing and packaging centers for bulk and break-bulk cargo. The most effective seaports provide competitive and efficient transfer, inspection, storage, form change, packaging, and control of cargo. This has an ever increasing influence on the volume of cargo (Frankel, 1987, pages 2-9). This cargo volume generates a substantial amount of income, employment, and demand for real estate.

Consider the following information. A study prepared for the Commonwealth of Virginia estimated that 67,774 employees are directly and indirectly related to ports in Virginia. The same study estimates that the Virginia port activities generate \$1.2 billion in payroll and \$143 million in tax revenue (Yochum and Agarwal, 1989, page 54). Another study (on the Port of Baltimore) estimated that port activities

generate employment for 52,000 people, a payroll of approximately \$1.5 billion and tax revenues of about \$57 million (Martin Associated, 1987, pages 3-9). A third study (on the Port of Houston) calculated that about 110,574 jobs, \$2.9 billion in business revenues and \$116 million in tax revenues are related to port activities (Martin O'Connell Associates, 1987, pages 4-10). Finally, an informal study prepared by the Port of Miami, on activities related to the port, indicated total economic impact of about \$4.8 billion (see Exhibit 4.1). Thus, research on these four seaports suggest that seaports create a considerable amount of jobs and income for a region and a metropolitan area.

With employment comes the demand for work space, a significant portion of which is needed in the immediate area surrounding the seaport. Consequently, the impact of a large efficient seaport on the demand for commercial real estate in the surrounding metropolitan area is considerable. And, as the volume of cargo increases so will the demand for commercial real estate space in the metropolitan area.

COMMERCIAL REAL ESTATE DEFINED

Because commercial real estate is a broadly defined term, a more precise definition is appropriate. For the purpose of this analysis, commercial real estate will include three primary types of space:

- i) Class A & B office space,
- ii) Low-rise and Office/warehouse space, and
- iii) Manufacturing and Processing space.

Office Space:

Office space in this study includes mid-rise (4-8 stories) and high-rise office buildings (over 8 stories). This type of space is more expensive and the user characteristics are different than in low-rise office, office/warehouse and manufacturing space. In Miami, for example, downtown office space is going for approximately \$25 p.s.f. versus low-rise office of \$10 to \$12 per square foot, office/warehouse space at \$8-\$10 per square foot, and pure warehouse at \$3-\$5 per square foot (personal interviews).

Low Rise Office and Office/Warehouse Space:

Office/warehouse is a somewhat nebulous term used for buildings that are basically built for warehouse use. However, these buildings are also used as inexpensive office space. Historically the office build-out for warehouse space has been 10%. Today many firms are taking advantage of this cheaper form of office space to house administrative and clerical staffs. Hence, office/warehouse buildings today are not only being used by the traditional users (those which require storage space), but also by business that utilize the space for administrative and clerical functions. In relation

to seaport activity, importers and exporter are an example of the traditional users, and freight forwarders and custom brokers are examples of the new users.

A more exact definition of office/warehouse space for this study includes:

- (i) low-rise office buildings (for management and administrative staffs of cargo related businesses) primarily attached to warehouse space,
- (ii) warehouse space being used as office space, and
- (iii) warehouse space being used for the storage of goods with some small amount (approximately 10%) set-aside for management and administrative activities. The definition of office/warehouse space does not include retail sales space, or storage space located in mid-rise or high rise office buildings.

The author is aware that a seaport may cause demand for other spin-off types of real estate requirements, particularly retail, hotel, apartment, etc., driven by cruise traffic and employment in the seaport or by seaport users and their agents. However, these are outside the breadth of this study and will not be addressed.

STORAGE/WAREHOUSE SPACE - HOW MUCH IS NEEDED?

Storage of goods are, in essence, an inefficient activity. The optimal distribution of any product is to move it as quickly as possible directly from the producer to the final buyer. If products are stored along the way, then expenses increase and profits drop. The trend is towards a total transportation system, so well controlled, it can act as the storage system itself (Falconer and Drury, 1975, page 8). At the present time, however, the manufacturing and transport time for many products is such that warehousing of goods must occur for a company to be competitive, particularly if the goods are produced in large batches. Thus, warehouse and distribution buildings will be needed well beyond the end of the twentieth century (Falconer and Drury, 1975, page 8).

Seaports typically attract major storage and distribution centers in the surrounding metropolitan area. Thus, ocean borne trade is indicative of an industry that requires substantial storage space. This is primarily due to the lengthy transport time and quantity of goods delivered. Cargo ships usually carry cargo volumes equivalent to the capacity of hundreds (or thousands) of trucks or railcars. These vessels must be loaded to capacity and sail great distances before products are available for purchase. The combination of great volume arriving at one time (usually without a final buyer) generates two possibilities. First, the goods can be

transported (usually via land) to another destination or, second, the cargo can be stored in the metropolitan area. Consequently, seaports will continue to act as major storage and distribution points for ocean borne cargo resulting in abundant demand for warehouse space.

The type and amount of warehouse space that is needed in a metropolitan area resulting from a trade activity at the seaport is dictated by several factors:

- (i) product type and form;
- (ii) storage technology;
- (iii) final destination of cargo;
- (iv) perishability;
- (v) product value; and,
- (vi) availability and cost of space.

Product type: The form and unit size in which cargo reaches a seaport is a prime consideration in determining storage type, space and volume requirements. Bulk, break-bulk and containerized cargo have different unloading, storage and distribution needs. Bulk cargo typically requires large single-use buildings, located at the seaport, to accommodate the storage. Examples are transit sheds, storage bins, storage tanks and silos. Break-bulk cargo may require large areas (many times open storage) for stacking and distribution. Containerized cargo utilizes more expensive and smaller

dock-high warehouse usually located off the port.

Technology: Cargo and handling or transfer technology is also a factor in the demand for storage space. Improved utilization of warehouse area can greatly reduce the amount of storage space a company requires. Developments such as automatic stacking and retrieving devices, computerized cargo locator systems, narrow aisle automated pallet movers, etc., all improve the efficiency of warehouse space so that more products can be stored and retrieval is faster (Frankel, 1987, page 651).

Final destination of the product has considerable influence over the demand for space in a metropolitan area surrounding a seaport. If the imported product is for local consumption then storage needs are normally required in the metropolitan area. If consumption of the goods are out of the metropolitan area or out of the region, then the goods might only pass through the metropolitan area in route to a warehouse closer to final sale.

Intermodal cargo is an excellent example of this situation. For example, at the Port of Miami, a moderate amount of imports are destined for either up-state Florida or other regions in the United States. These goods typically departed from either Latin America, the Caribbean or Europe and because

of lower cost and/or faster delivery, importers of goods choose the Port of Miami as the port of call. In the case of Miami, the goods arrive at the port in containers, the containers are placed on trailers, picked up by trucks, delivered to Florida East Coast Railroad's intermodal facility in Hialeah, Florida (15 minutes from the port), temporarily stored, and then loaded onto flat-bed rail cars for transportation north. As a result, the storage time for this cargo in Miami is very short. Thus, with intermodal cargo, storage needs are less, compared to other imported cargo. (Refer to Frankel's book, Port Planning and Development, pages 538, and 637 for more detail on intermodal transportation.)

Transshipment Cargo is another example of the impact that final destination has on storage space. This type of cargo is typically stored at the port because it requires only temporary storage in route to a smaller and/or less developed seaport. Large shipping vessels usually have one port of call, at which point the cargo is usually discharged from the ship and reloaded onto another ship after temporary storage, consolidating, and sometimes repackaging and form change. This cargo is then reloaded onto feeder vessels (much smaller ships) for delivery to less developed seaports. These undeveloped seaports lack either, the demand for a large shipment of cargo, adequate unloading facilities, or deep water channels. Most Latin American seaports fall in to one

of the above categories.

Product perishability also is a determining factor in warehouse space. Typically, products that require refrigeration have a short shelf life and remain in inventory for only a few days before transport. Inventory turns over every couple of days. Thus, the peak inventory volume is closer to the average and less storage capacity is needed. For example, efficient storage of refrigerated fruits requires staggering the orders so that the previous order is removed from the warehouse before the next order is delivered. This is known as just-in-time inventory management. Less storage space is needed in this process than (say) a business that receives infrequent but large shipments from a cargo ship.

Value: The value of the cargo is a primary determinant for storage needs. The higher the value of the product, the more expensive the carrying costs. This inventory must be financed by the importer and the longer a product remains in inventory, the higher its cost. Profitability not only is dependent on profit margins of the product, but also on how fast the product can be sold; i.e. idle assets do not make money. The objective for high value products such as computers, certain electronic components, medical equipment, etc. is to deliver the goods from the manufacturer to the final buyer as soon as possible. Therefore, importers of high value products must be

extremely efficient with their inventory, which leads to a more efficient use of warehouse space.

Availability and Cost of Space: Availability and cost of space are closely related. The amount of space available usually determines the market rent. If a metropolitan area has sufficient warehouse space available, then the cost will be more competitive, and thus the cost of storage will be competitive with other storage markets. If the warehouse market is "tight", then prices rise and storage costs increase. This might cause storage to become more efficient or move to another metropolitan area.

CRUISE SHIP INDUSTRY

The cruise industry is represented by many businesses and activities, as it involves both the lodging industry and seaport operations. Thus, the economic and commercial real estate impacts associated (directly and indirectly) with the cruise industry are substantial. First, a discussion of cause and effect relationships between the primary components of the cruise industry. Next the various types of real estate used by the cruise industry will be addressed.

Cause and Effect Relationships:

Everything in the cruise industry evolves around passenger volume (present and perceived future volume, which can be

divided into two primary subdivisions: shipping and professional support services.

Relative to shipping, cruise line companies and cruise suppliers are most directly impacted by fluctuations in passenger volume (or rather the potential demand for passenger volume). Suppliers (particularly food and beverage suppliers) feel the effects of fluctuations in passenger volume first. The volume of food, beverage and every day supplies are directly correlated to the number of passengers which sail every week. The level of supplies that are needed each week determines the amount of space that is needed for storage and the people that manage and handle the goods. Although the storage requirements may change quickly, other factors such as lease terms, building ownership and financial condition of the vendor, play a large role in when a firm decides to actually expand or contract its storage space.

Port terminals and cruise line companies are impacted by passenger volume more on an annual basis. The number and size of the cruise ship vessels and their calling frequency are determined by annual and future projections of passengers counts rather than weekly or monthly fluctuations. The number of vessels, in turn, determines the number of employees working directly for cruise ship companies. Employee numbers can be used to establish real estate demand. However, as

mentioned above, there are other factors that dictate short term space decisions.

Passenger volume, also governs the volume of business for travel agents booking cruise vacations, airlines that fly passengers to the port of origination, baggage handlers, customs and health authorities, taxi transportation from airport to seaport, and to a lesser degree, a whole host of indirect business for local retailers, restaurants and hotels. As the labor force grows to accommodate more passengers, more space is needed to house the employees.

Cruise activities that are impacted more by long term changes in passenger volume are professional support services and ship handling services (see Exhibit 4.2). For example, adding employees to the professional services category is determined by a notable long term increase in passenger volume rather than a linear relationship. Also, the expansion in ship handling activities is based on new berthing for cruise vessel and/or additional sailing trips, rather than an increase in passengers. Both of these do not change much with short term changes in passenger volume.

On a microeconomic level, the economy and commercial real estate in a metro area will only benefit directly from the cruise industry if the port can attract cruise vessels for a

home berth. (A port-of-call berth generates significantly less impact on both the local economy and commercial real estate.) The number of cruise vessels a particular port is able to capture for a permanent berth will determine the employment and, hence, the real estate demand from the cruise industry in a metropolitan area. Exhibit 4.2 below provides a flow chart of the various dependencies between the components of the cruise industry.

EXHIBIT 4.2

DEPENDENCY BETWEEN VARIOUS ACTIVITIES OF THE CRUISE INDUSTRY

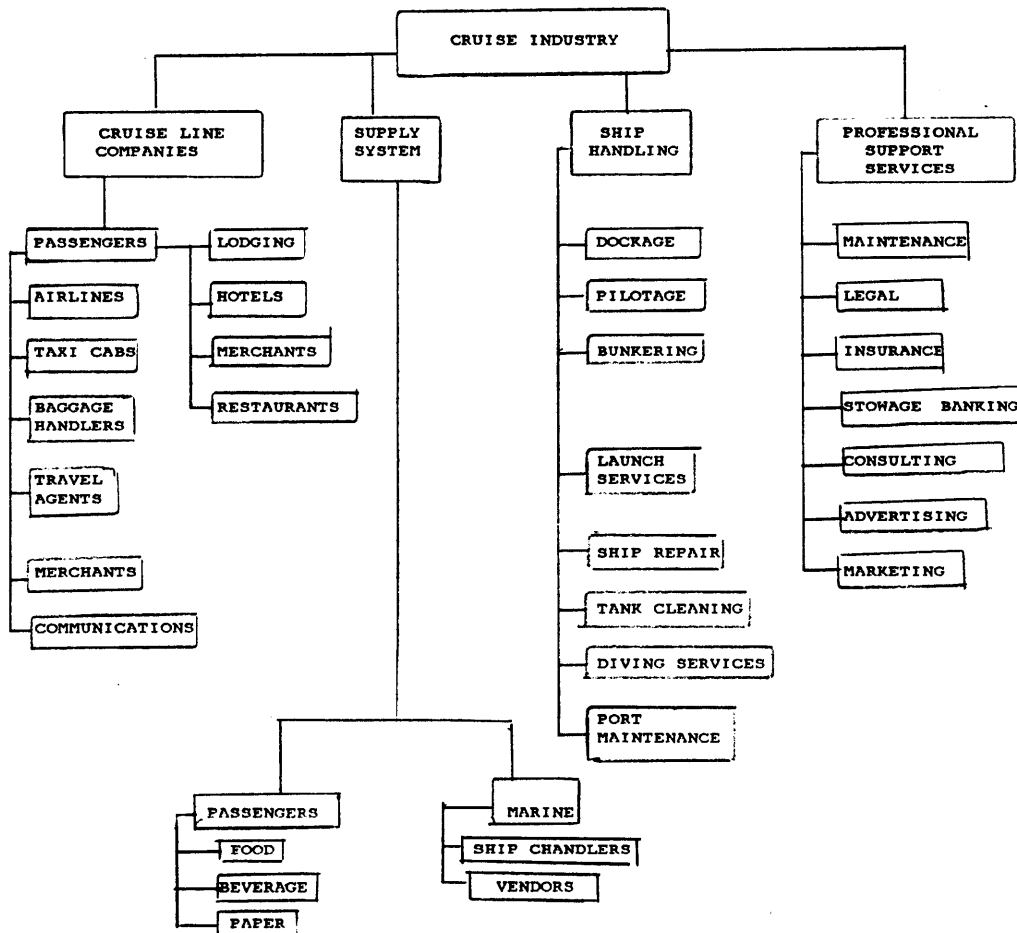

Each of the cruise industry dependent components or activities in Exhibit 4.2 generates real estate demand as a function of its cruise dependent business. For example, a 10% increase in cruise passenger volume could increase real estate demand by all these activities by 5-20%, depending on the form or characteristics of the passenger volume increase.

Commercial Real Estate Linked to the Cruise Industry:

The Cruise industry uses several different types of real estate depending upon the segment of business. Many of the activities are office users, as well as, low rise or office/warehouse users. To a lesser degree companies related to the cruise industry requires specialized storage. Exhibit 4.2 on the following page provides a matrix for all primary business related to the cruise industry and the type of commercial real estate they would use in metropolitan area.

Office Space Related to the Cruise Industry:

The largest user of prime office space from the Cruise Ship Industry are the Cruise Ship Companies. These companies have a substantial amount of management and administrative staff and they must present an image of integrity, success and stability. Similar to a shipping company, the amount of office space a Cruise Ship Company needs in a seaport area depends the status of the operation (i.e., is the operation a headquarters, regional office or port of call location).

EXHIBIT 4.3

CRUISE INDUSTRY/COMMERCIAL REAL ESTATE DEMAND MATRIX

	X=Primary Use O=Secondary Use	High-Rise Office Space Users	Low-Rise & Office Warehouse Users	Standard Warehouse Users	Specialized Warehouse Users
CRUISE PASSENGER HANDLERS					
- Cruise Line Companies	X		O	X	
- Travel Agents	X		O		
- Airlines	X		O	X	O
- Taxi Companies			O	X	
CRUISE SUPPLY SYSTEM					
- Food Vendors	O		X	X	O
- Beverage Vendors	O		X	X	
- Ship Chandlers			O	X	
- Publishing	O		X		
- Paper Supplies			O	X	
- Retail Goods			O	X	
- Trucking	O		X		
- Cleaning Chemicals	O		X	O	
CRUISE SHIP HANDLING					
- Pilotage			X		
- Bunkering			X		
- Towage	X		O		
- Ship Repair			O	X	
- Ship Maintenance			O	X	
- Marine Parts Supp.	O		X		
- Tank Cleaning			O	X	
- Launch Services			O	X	
- Diving Services			O	X	
PROFESSIONAL SERVICES					
- Banking	X		O		
- Legal Services	X				
- Insurance Co.	X		O		
- Insurance Agents	X				
- Advertising Co.	X				
- Marketing Companies	X				
- Cruise Consultants	X				

A case in point is metropolitan Miami. The Port of Miami handled approximately 3 million passengers in 1989 with more passenger ships sailing from the Port of Miami than from any port in the world. It is home to 23 cruise ships operated by 12 companies through 12 terminals (Port Of Miami, Official Directory, 1989, page 26). Companies such as Royal Caribbean Cruise Lines, Carnival Cruise Lines, Commodore Cruise Lines and Norwegian Cruise Lines (NCL) sail several vessels regularly out of the Port of Miami. These companies also have there headquarters located in Metro Miami. As a result, Miami/Port of Miami is considered the cruise capital of the world.

The four largest cruise lines rent a significant amount of office space in metropolitan Miami. Royal Caribbean is building a 7 story, 160,000 square foot office building at the port to house approximately 1000 employees (160 s.f. per person). Carnival Cruise Line rents 220,000 square feet in a 10 story building, known as One Doral Place, in the suburban section of Miami. NCL recently leased 100,000 square feet in a new building in Coral Gables, Florida (a suburban office hub 10 minutes from the Port of Miami). Commodore is moving into 40,000 square feet of space, also located in Coral Gables (personal interviews). All this suggest that Cruise line companies require a substantial amount of office space within 15 minutes of the port. Growth expectations in the cruise

industry will determine if cruise lines rent around 150 square feet per employee or "bank" addition space for future growth.

Other users of office space, related to the Cruise industry, are professional support firms and vendors. Like cargo activities, the cruise industry requires certain professional support services, although to a lesser degree than the cargo industry. For example, the cruise companies require services from banks, public relation firms and consultants. Legal and insurance support is also required by cruise lines, but to a lesser degree than the cargo industry. Vendors may also require some office space. The vendor business supporting the cruise industry is substantial. Cruise Ships demand large amounts of food, beverages and supplies. The larger vendors may require some office space for their management and administrative staffs.

Government agencies require some office space. Federal government port activities consist primarily of channel and harbor improvements, customs, safety programs, administration, research, promotion, international representation and regulation (Port Authority of New York and New Jersey, 1978, page 21). State and local governments also provide services and investment for port activities. Usually the land and/or the facilities are owned either by the state or local government. For example, Dade County owns and controls the

land and facilities (gantry cranes, terminal, etc) at the Port of Miami. In turn, the Port of Miami leases the births, terminal and cranes to several shipping companies and cruise lines.

These agencies require space to conduct business. The managing and administrating personnel are typically housed in office space. For instance, the Port of Miami locates all their managerial and administrative people in a mid-rise office building at the port. Many of the federal government workers are also located in office space (although it is usually class B space). The labor and many times the clerical workers are housed in less expensive space such as low-rise office/warehouse space.

Office/warehouse space Related to the Cruise Industry:

The cruise ship industry absorbs a notable amount of office/warehouse space. Food and supplies use most of the storage space. For example, the Port of Miami had 3.1 million passengers through the port in 1989. Assuming the average cruise is 7 days, and cruise ships sail an average of 50 weeks per year, then the average weekly passenger count through the port would equal 62,000. The average person consumes approximately 5 pounds of food per day. Thus, the required food supply for the Miami cruise industry must equal 310,000 pounds per week. This food supply comes from a variety of

sources. Cruise line companies have some food inventory, while food vendors have storage requirements for the remaining portion. Hence, it is easy to see that the storage requirements for food alone is significant.

A substantial amount of storage is additionally required for items such as other passenger provisions, marine parts, furniture, christmas ornaments and advertising brochures. As a result, a large wholesale storage operation has evolved in Metropolitan Miami to constantly support the Cruise industry with provisions.

The amount of food and supplies produced in the metropolitan area as opposed to the region will also have an impact on the amount of storage space require in that metropolitan area. For instance, if much of the food is shipped in from outside the metropolitan area, the local storage demand will not be as high as if the majority of supplies are produced inside the metropolitan area.

Cruise line companies typically require about the same amount of storage space as office space (Fernandez, 1990). For example, Royal Caribbean Cruise Line requires approximately 160,000 square feet of class A office space. They also require about the same amount in storage space. The actual amount of space a cruise ship company would require depends on

amount of storage space require in that metropolitan area. For instance, if much of the food is shipped in from outside the metropolitan area, the local storage demand will not be as high as if the majority of supplies are produced inside the metropolitan area.

Cruise line companies typically require about the same amount of storage space as office space (Fernandez, 1990). For example, Royal Caribbean Cruise Line requires approximately 160,000 square feet of class A office space. They also require about the same amount in storage space. The actual amount of space a cruise ship company would require depends on the level of vertical integration the company has. Many of the larger cruise ship companies have decided to acquire suppliers in the chain of support.

Another segment of the cruise industry that require warehouse space is ship maintenance and repair business. Storage space is needed for marine parts and equipment. Dry docking and other repair space requires specialized storage space.

CARGO/TRADE INDUSTRY

The cargo industry, like the cruise industry, is represented by many business and activities. It is supported by shipping, trade activities such as importing and exporting, and

professional services. The economic and commercial real estate impacts associated (directly and indirectly) with the cargo industry are substantial. For example, the import export business alone contributes a substantial amount of income and jobs, and absorbs a considerable amount of commercial real estate.

The cargo industry is a closely linked chain of activities that enable cargo to travel great distances and arrive on time and with limited damage. Some of these activities are more closely linked with actual cargo volume, while others are further down the chain and basically respond to actions of other firms in the cargo business. The following section describes these relationships.

Cause and Effect Relationship:

Ocean borne sea trade is driven by demand for imports and exports and availability of at least an adequate seaport. All activities associated with the handling and movement of ocean cargo is impacted (some more than others) by changes in the cargo volume. For purposes of explaining the different relationships, the cargo industry is subdivided into three categories: shipping, trade activities and professional support services. Exhibit 4.4 on the following page describes these relationships in the form of a flow diagram.

Exhibit 4.4

DEPENDENCY BETWEEN VARIOUS COMPONENTS OF THE
CARGO/SEA TRADE INDUSTRY

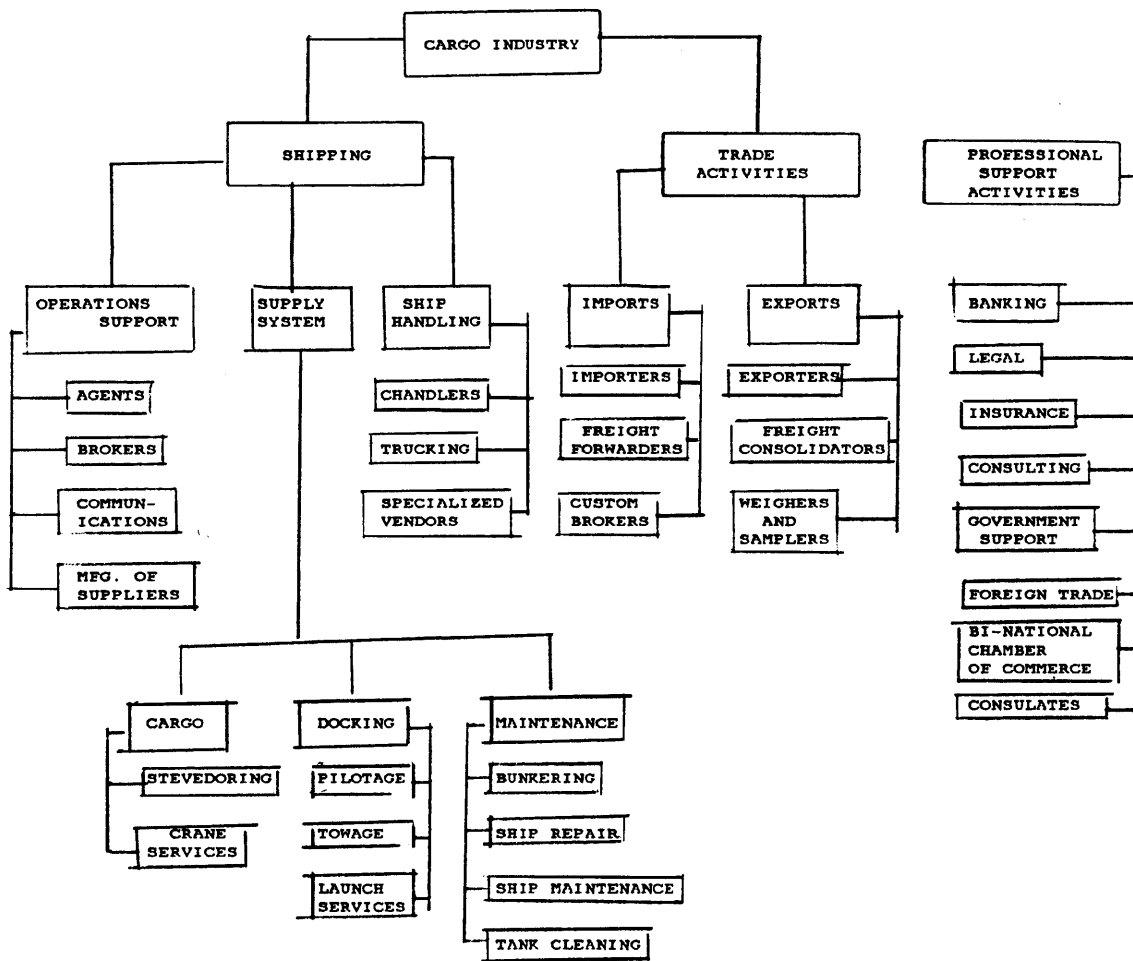

The first category above, shipping, is closely correlated to the level of cargo moving through a seaport. The activities under this segment of the industry include operations support, the supply system and ship handling activities. Shipping operations (i.e., shipping companies, agents and brokers) expand or contract based on the medium and long term cargo volume sustained at a seaport. If cargo volume is increasing, shipping companies may add more vessels (or larger vessels),

and/or employees. Agents and brokers would also expand. However, expansion does not have a direct linear relationship with cargo volume. Rather, expansion for ships is dependent upon existing capacity and future growth to justify the additional capacity of another vessel. Expansion of employees, on the other hand, responds more gradually to an increase in cargo volume. Employee expansion occurs at various levels of activity. For example, existing agents can usually handle increased cargo volume for six months to a year before someone new is hired.

Cargo ships require a substantial amount of food and marine supplies, although, not as much as cruise ships. Most of this is provided by a ship chandler who, in-turn, requires trucking and products from manufactures and other suppliers. Ship chandler supplies are directly correlated to the number, frequency, and size of the vessels calling on a seaport. Thus, cargo volume, which eventually determines the number, size and frequency of vessels, does not have an immediate impact of the activities in the supply system. Ship handling, similarly falls into this status.

Trade activities, on the other hand, are directly correlated to cargo volume. Any small change in cargo volume will immediately impact the profitability of an importer or exporter. As will be noted later, a change in cargo volume

will not immediately change the real estate needs of the trade activities.

Profession support activities relative to shipping and trade, react the slowest to any changes in cargo activity.

Typically, there will be no change in employees or space until there is a notable change in cargo volume over time.

Commercial Real Estate For the Cargo Industry:

The cargo industry, similar to the cruise industry, also requires many different types of commercial real estate uses. Predominately, however, cargo related business require some form of storage with low-rise office space attached. Exhibit 4.5 on the next page provides a matrix addressing each primary user and the type of space needed.

Office Space Related to the Shipping Business:

There are several different business that operate in conjunction with the seaport and require office space (see Exhibit 4.5 for the primary users).

EXHIBIT 4.5

CARGO INDUSTRY/COMMERCIAL REAL ESTATE DEMAND MATRIX

X=Primary Use O=Secondary Use	Office Space Users	High-Rise & Office Warehouse Users	Low-Rise Standard Warehouse Users	Specialized Warehouse Users
CARGO TRADE				
- Importers		O	X	X
- Exporters		O	X	X
- Freight Consolidators		O	X	
- Freight Forwarders		X		
- Custom Brokers		X		
- Weighers & Samplers			X	
- Container Maintenance		X		
CARGO SHIPPING				
- Shipping Companies	X	X	O	
- Shipping Agents	O	X		
- Ship Brokers	O	X		
CARGO SUPPLY SYSTEM				
- Ship Chandlers		O	X	
- Food Vendors	O	O	X	X
- Beverage Vendors	O	O	X	
- Packaging		O	X	
- Dunnage		O	X	
- Trucking Company	O	O	X	
CARGO SHIP HANDLING				
- Bunkering		X	O	X
- Ship Maintenance		O	X	
- Stevedoring		O		
- Ship Repair		O		
- Pilotage		O		
- Towage		O		
- Crane Services		O	X	
CARGO PROFESSIONAL SUPPORT				
- Banking Institutions	X	X	O	
- Legal Firms	X			
- Insurance Companies	X	X	O	
- Government Agencies	X	X		
- Foreign Trade Offices	X			
- Consulates	X			
- Bi-National Chambers	X			

Headquarters and regional offices of shipping lines are one of the larger users of office space. If the operation is sizable enough, then the management and administrative staff will be housed in office space. Price is also a determining factor. If office space is too expensive (such as in New York city), then these companies may choose an alternative, such as office/warehouse, or low-rise office space in a suburban area.

The amount of space used or needed depends on the number of people employed at a particular seaport location. Growth expectations are also a major determinant in space requirements. For example, efficient use of office space for a shipping company is approximately 150 to 250 square feet per person (personal interview). If 200 hundred people are employed then the shipping company would require between 30,000 and 50,000 square feet of space. However, if growth in trade and shipping activity is expected then perhaps a shipping company may "bank" some space. In this situation, average space per employee would increase to 400 or 500 square feet per person initially and reduce as the firm adds more employees in the future to the same amount of space. In this situation, the same 200 employees would initially be housed in 80,000 to 100,000 square feet of space.

Miami has 59 ocean going carriers and 41 steamship lines operating out of the Port of Miami and located in the metro area (South Florida Trade Services Directory, 1990). Although the space requirements of these firms may differ substantially, the management and administrative employees are located in office space. Actual space requirements can be determined by calculating the total people employed by these firms, assuming an outlook for growth and assuming a space per square foot factor for each employee.

Office Space Used By Professional Support Services:

Professional services supporting the cargo industry are another big user of office space. The import and export of ocean borne cargo requires the expertise of bankers, lawyers, insurers and accountants. Other professionals supporting the cargo industry are consultants, advertisers and marketers. Because of the need for image and location, class A office space is normally the standard choice of work space. Furthermore, the firms employing these professionals usually lease more space per worker (approximately 250 to 350 square feet is the norm) than private industry (confidential interview). This is possibly due to the higher mix of professional level employees which require well appointed large offices compared to administrative staff which has work stations in much smaller areas.

Miami, for instance, has 40 foreign banks, 27 edge act banks, 32 domestic Florida banks with international departments and 2 Latin America regional offices of major multi-national banks (South Florida Trade Services Directory, 1990). All these firms combine to absorb a significant amount of office space. It should be noted that these firms also handle significant business related to cargo moved through the Miami airport, however, the majority of operations are associated with the Port of Miami.

Other users of office space related to the cargo industry include foreign governments and large vendors. Countries that import or export a considerable level of goods through a particular seaport usually have representatives and consultants located near that port. These individuals typically choose office space as their work area. Also, some large vendors that supply food and supplies for the crews of cargo ships may demand office space for the managerial and administrative staff. However, vendors usually rent low-rise space attached to the warehouse facility for the management and administrative employees.

Miami has 22 foreign trade offices, 12 bi-national chambers of commerce and 48 foreign trade consultants. Their primary function is to facilitate the movement of ocean borne cargo. Some of the firms are two or three person operations but others are substantially larger and they combined to use a moderate amount of office space.

Cargo Businesses That Use Office/Warehouse space:

This section of the seaport industry can be subdivided into two areas: trade activities and cargo support activities. Trade activities include importers, exporters and freight consolidators. Cargo support activities include businesses such as custom brokers, shipping agents, freight forwarders,

stevedores, truckers and ship brokers. Each of these activities are discussed in the following sections.

Importers: Importers are probably the most intensive users of office/warehouse space (i.e., they require storage space, as well as, space for management and administrative personnel. The amount of space an import company requires depends on many factors. The type of product they are importing, the final destination of the product, the perishability of the cargo and the value of the goods are all factors in determining the amount and type of space and the number of people required to effectively manage, store and distribute the goods. A specific example is two importers of containerized cargo. A company that imports ceramic tile from Italy has significantly different storage and working space needs from a company that imports fresh fruits from Costa Rica.

An exception to this rule is a concept that was discovered in the Miami metropolitan area. First some background on floor tile. Floor tile (clay and ceramic) is one of the Port of Miami's largest import items. It arrives in containers and is picked up by truck and transported to either the direct buyer to storage. Typically, the tile arrives at the port, and is transported to a local warehouse in Metropolitan Miami to await final sale and delivery by truck. Rail-cars are not used due to potential breakage.

Until recently, the majority of tile imported through the Port of Miami was sold within the state of Florida (particularly south Florida). Presently, the sale of floor tile is spreading through-out the southeastern United States. During an interview with one of Miami largest tile importers, it was discovered that their warehouse contained tile inventory from a tile company located in Atlanta, as well as their own inventory. This Atlanta tile company, rather than ship it to Atlanta from the Port of Miami, would store the tile in a Miami warehouse. When a sale was made, the tile would be released from the Miami warehouse and shipped to the final destination. It seems that due to the volume of tile moving through the Port of Miami, port costs and labor expertise, it is cheaper to import tile through the Port of Miami rather than through a port closer to Atlanta.

After further investigation into this remote storage concept we discovered the following. First, the Miami tile importer is presently using only 50% of its warehouse space. The extra space is in anticipation of growth. Thus, management is "banking" warehouse space for future use. Second, because the importer has space available the out-of-state importer has the option to rent the space. Third, the Miami importer is not charging rent, in the standard form, for the use of the storage space. Instead of monthly rent, the Miami importer

has an arrangement whereby it can use this inventory of the Atlanta company at cost plus a small percent fee. Therefore, the Miami importer has access to a larger inventory with out paying for the cost to carry the tile inventory. In summary, anticipation of future growth or subletting demand can effect an importers decision on how much storage space is needed.

Exporters are also users of office/warehouse space. Exporters typically require a facility with both storage and office space. The demand for storage space in a metropolitan area generated by seaport trade depends primarily on where the exported goods are produced and if the exporter is acting as a distributor. For example, bulk cargo may be transported directly from the producer to specialized storage at the port and, thus, would not require dock-high warehouse space for storage. The importer of this cargo may only have managerial and administrative staff located in the metropolitan area surrounding the port, which would require some low-rise office or office/warehouse space.

Containerized cargo that is transported via piggy-back rail cars is another example of goods that do not require dock-high storage space in the metropolitan area. This cargo is transported either to an intermodal facility or directly to the port. If the cargo is transported to an intermodal

facility in remains their for a short period and then moved to the port. Thus, a port that is increasingly used as an intermodal export terminal for a region's products will generate demand in intermodal warehouse space but not the typical office/warehouse space inhibited by exports located in the metropolitan area.

Freight consolidators are typically a large user of office/warehouse space. These companies provide cargo consolidation points for export orders which are not large enough to shipped cost effectively. By nature of the business freight consolidators typically handle containerized cargo. Export orders that are not large enough to fill a container to a specific country are shipped to a freight consolidator who consolidates several orders to fill a container for a specific destination. The Miami metropolitan area has a large contingency of freight forwarders. They receive goods destined primarily for Latin America. For example, a freight forwarder may consolidate televisions, furniture, electronic goods, etc. sufficient to fill a container to Venezuela. This appears to be more cost effective than shipping a partially full container.

The type of space requirements for a freight consolidator are similar to an importer (i.e., dock-high warehouse space with a small amount of space set aside for office activities). These

companies are typically located in the metropolitan area encompassing the port of export. The demand criteria is similar to that of importers of container cargo (i.e., product type, final destination, product value, and availability and cost of space).

Suppliers, Ship Handlers and Misc. Users: Other users of a combination of office/warehouse space include ship chandlers, packing and crating businesses, trucking companies, and any companies that either sell a tangible product to the port or must keep a spare parts inventory. The largest user in this group are ship chandlers who provide vessels and the crews with supplies. Also, trucking companies may require some indoor storage space for trucks, repair space and storage space for spare parts. With the exception of ship chandlers, these businesses are not considered significant users of office/warehouse space relative to importers and freight consolidators.

Low-Rise Office Users:

There are several businesses which support port activities but do not need warehouse space. However, they do require inexpensive office space, which is easily supplied through warehouse buildings with an interior office finish. Shipping agents, shipping lines, freight forwarders and government agencies are the largest users of office/warehouse space from

this group. Stevedoring companies, on the other hand, do not require much space. In general, these business are located in low-rise office or office/warehouse space situated in the metropolitan area surrounding the port. These business also tend to locate in clusters of import and export companies.

Shipping Companies: Information regarding the amount of space and employees for four of the larger shipping companies in Miami indicates that firms used between 140 to 200 square feet per employee. The decision to expand at these companies occurs somewhere around 150 square feet per employee or less. Whether they actually expand depends on expected growth, cost and availability of new space, and the financial stability of the company (Roviroso, June, 1990).

It should be noted shipping companies may have other operations under their roof. For example, Farovi Shipping Corporation and Florida Stevedoring Inc. are essentially owned and operated by the same management. This company requires a small amount of space at the port and off the port for the stevedoring operation. Thus, the majority of Farovi's space is used for the shipping business.

Freight Forwarders: There are 408 freight forwarders in metropolitan Miami, which employ approximately 1,161 people. An interview with Danzas provides insight to the space needs

of a freight forwarder. It should be noted that Danzas is also a freight consolidator and custom house broker. Danzas is located in a building that was custom built for their operation. The building has an office component attached to a warehouse. The office section amounts to approximately 9,200 square feet and houses 54 employees (172 square feet per employee). The warehouse section is about 28,000 square feet and considered crowded. Expansion is planned for an estimated 48,000 square feet (De Tuya, 1990).

Professional Services: Professional support businesses such as banks, insurance companies, and government agencies may choose to house the administrative/operational employees in low-rise class C office or office/warehouse space because of the cost savings. This choice is becoming prevalent as firms realize the rent savings and in some cases operational efficiencies associated with office/warehouse and low-rise office space. These firms may also require some storage space. For example, government agencies such as the Corps of Engineers, Coast Guard, Customs, etc. require some storage space.

DEMAND FOR SPECIALIZED STORAGE AND PRODUCTION FACILITIES

The manufacturing and processing segment of business activity associated with ocean borne cargo requires three different types of space. A small portion of office space is required

for the management and administrative employees. As mentioned earlier, these employees are housed in either office space or office/warehouse type space. The second type of space requirement is a working area for the actual manufacturing or processing of materials into the final products. The third variety of space is for storage of these goods. The latter two (manufacturing/processing and storage space) will be discussed in the sections below.

The demand for either manufacturing or processing space in a metropolitan area depends on the raw materials and the final output. In relation to the port industry, the volume of bulk cargo a port handles and whether this cargo is an import or export is a major determinant in the amount and type of processing manufacturing space, and/or storage space that is required in a metropolitan area.

Demand for processing plants occur from imports of bulk cargo such as grain, coal, petroleum, sugar, etc. For example, if a port is a major grain importer then processing plants are typically located on the port or near by to maximize continuity of bulk cargo flow from ship to processing. Crude petroleum is handled/processed in much the same way. Hence, if a port is a major importer of bulk cargo, a significant amount of processing space must be located in the metropolitan area.

The demand for manufacturing space is typically generated for different reasons. Manufacturers are primarily concerned with production costs. As such, manufacturing location is based on access to workers, wages and productivity, land costs, access to highways and rail lines, and taxes. Shipping costs have become trivial in the industrial location decision (Wheaton, 1990). Accordingly, a manufacturer does not decide to locate near a specific port unless it will offer some unique advantage. Once the location is chosen, then the seaport values from exports of that product. Although, port activity basically does not generated demand for manufacturing space, increasing exports of a manufactured product may signal that more manufacturing space is needed. Available plant capacity, however, must be considered in determining additional space requirements.

The demand for manufacturing space related to port activities in metropolitan Miami is minor compared to office and office/warehouse space. Metropolitan Miami's primary manufacturing products are furniture, apparel and textile goods, food processing, fabricated metal products, and printing and publishing. Food processing and apparel goods are the most closely related to the Port of Miami. These companies export large amounts to Latin American and the Caribbean. Their location to the Port of Miami offers a

distribution advantage over competitors located outside the metropolitan area. because the Port of Miami offers the cheapest distribution routes to Latin America and the Caribbean.

Storage space demand for manufacturing and processing operations can be significant from either imports or exports and is directly related to port location, capacity and efficiency. The best example of storage for manufacturing and processing operations is bulk cargo. Because bulk cargo vessels handel large volume and weight and ship turnaround time is critical, bulk cargo is usually stockpiled at a port awaiting pick-up and then stored again at the destination port before manufacture or processing. Coal mined in the United States and destined to a foreign country is a good example. It is shipped via rail to an east coast port, stored is vast quantities awaiting pick-up, and then stored again at a foreign port awaiting processing and/or distribution. The port of Miami does not handel bulk cargo and thus, does not have demand for bulk cargo storage space. It should be noted that the type of storage for bulk cargo is very specialized. Examples of bulk storage are silos, storage tanks, ponds storage trenches and large storage sheds.

In summary, demand from port activities for manufacturing space is insignificant. Other factors in the metropolitan

region rather than attributes of the area's seaport drive growth in manufacturing. Demand for processing space in a metropolitan area is directly related to a seaport's location, capacity, physical facilities and efficiency. Storage space for processing bulk cargo is also related to a ports characteristics.

SUMMARY OF SEAPORT ACTIVITIES AND COMMERCIAL REAL ESTATE

The amount of commercial real estate demanded in a metro area by the port industry is abundant. However, the structure and amount of space can differ significantly depending on the type and destination of cargo, present cargo volume and the future growth expectations.

Cruise companies, for example, can generate a substantial demand for high-rise office and warehouse space in a metro area. Office space will be required to house the managerial and administrative employees of the cruise ships, travel agencies, airlines, professional services, etc. Warehouse space will be needed by cruise ship companies and vendors to store the massive quantity of ship provisions required to support cruise passengers. Although passenger volume drives this demand, changes in passenger volume do not have an immediate affect on the demand for space. Rather, the demand for space is determined by long term passenger volume. Also, some business are influenced more than others by passenger

volume. Food vendors, for instance, feel the impact for changes in passenger volume on a weekly basis.

In comparison, cargo ports, particularly container cargo ports, generate a substantial level of demand for warehouse space and to lesser degree office and office/warehouse space. Importers and exporters absorb the majority of this warehouse space. Other support industries such as freight forwarders and custom brokers require low-rise class C office space. Warehouse space is dictated by several factors. The most important of these are cargo type, volume and destination. Office space for the cargo industry is determined by the number of employees a firm employs.

Cargo volume is the long-term driving force behind demand for space from cargo related business. Similar to the cruise industry, the demand is not correlated in a linear fashion. If cargo volume fluctuates in the short run, the space requirements for warehouse space will not change much, because most of the businesses either own the building or have three to ten year leases. Thus, immediate changes in space does not occur.

Demand for specialized storage such as warehouses for bulk cargo or refrigerated products are derived directly from the importing and exporting of specific types of bulk and

break-bulk cargo. Bulk, break-bulk cargo have distinctly different unloading, storage and distribution needs. Bulk cargo typically requires large single use buildings, located at the port, to accommodate the storage. Examples are transit sheds, storage bins, storage tanks and silos. Break-bulk cargo may require large areas (many times open storage) for stacking and distribution. Demand for specialized storage is directly related to the volume of bulk and break-bulk cargo.

CHAPTER FIVE
SUMMARY, CONCLUSIONS AND FUTURE IMPLICATIONS

SUMMARY AND CONCLUSIONS

It is clear that seaports are a vital trade link in a growing international economy. Ocean borne trade accounts for 82% of total world trade (i.e., 3.6 billion tons in global trade cargo out of a total of 4.4 billion tons occur through seaports). It is also evident that port technology and capacity have an ever increasing influence on attracting a portion of this trade. In fact, regional growth, and to a greater degree metropolitan growth, can be greatly impacted by the efficiency, location and capacity of the area's seaport.

The economic growth generated through a seaport brings jobs, income and wealth to the region and the metropolitan area surrounding the port. With these monetary benefits comes the demand for commercial real estate, a considerable portion, of which, is in the immediate vicinity of the port. Hence, a metropolitan area surrounding a large seaport typically serves as a major distribution and storage point for ocean borne trade.

How much demand and what type of space is needed is dictated by cargo type, volume, and destination, plus the availability and cost of space in the area. Cruise passenger volume, for example, requires a significant amount of office and warehouse

space. Container cargo volume, in comparison, has a strong impact on the demand for warehouse space, and to a lesser degree low-rise, mid-rise and high-rise office space. Bulk cargo volume, with completely different requirements, has a momentous effect on specialized storage space and manufacturing space.

Miami, Florida is an example of a metropolitan area that benefits substantially from a seaports ability to attract an increasing volume of trade, which in turn, generates demand for real estate. Because of the Port of Miami's strategic location and capital investment in cruise ship berths and terminals, Miami has become the cruise capital of the world. The cruise industry has been expanding rapidly in Miami over the past ten years and in 1989 more than 3 million passengers came to Miami to vacation on cruise ships. This growth has had a tremendous ripple affect through the chain of support for cruise vessels. Cruise companies, vendors and other support activities have been expanding with this growth, which has created increased demand for mid and high rise office space, as well as, warehouse space.

Container cargo volume has also demonstrated strong growth, in spite of Latin America's economic downturn in the early 1980's. Container volume increased 52% over the past 10 years, rising from 2.1 million U.S. tons in 1979 to 3.2 million U.S. tons in 1989 (Port of Miami statistics). There are several factors attributable to this rise in volume. It seems that location,

again, is a critical factor. Just as important is the Metropolitan area's capital investment in container facilities, combined with an adequate infrastructure for distribution of cargo and availability of storage space at competitive prices. Also, the Caribbean Basin Initiative has generated intermodal and free trade zone cargo activity in the past few years, while the chaos in Panama has created a growing transshipment business at the port. However, probably the most important reason, in the author's opinion for growth in container volume, is Miami's unique critical mass of bi-lingual and experienced workers to support cargo transfer. This quality appears to solidify all other attributes to establish Miami as the gateway to Latin America and the Caribbean.

As a result, the Port of Miami is now the largest container port in Florida and the eleventh largest container port in the United States. The port is also the cheapest distribution route to Latin America and the Caribbean, and the sailing port for the majority of feeder vessels to these areas. In addition, the Port of Miami is the leading transshipment point for exports from Europe and the Far East, destined for Latin America and the Caribbean, and the largest intermodal point for the Caribbean Basin Initiative. All this cargo activity at the port has led to increase demand for office/warehouse space, low-rise office space and to a lesser degree mid and high rise office space in the surrounding metropolitan area.

FUTURE IMPLICATIONS

There are several future implications for the port industry relative to commercial real estate in a metropolitan area. They are as follows:

- * Ports have become complex intermodal transfer and processing facilities that must respond quickly and efficiently to changes in commerce to remain competitive in capturing trade.
- * Ports such as Miami must continue to improve ship turnaround time, reduce traffic congestion, become more efficient in port container storage and strategically prepare for the future, if they are to continue their port related economic growth.
- * The Port of Miami, as capacity reaches its maximum, must decide what type of container cargo (local imports, intermodal or transshipment cargo) is the most economically beneficial for Metropolitan Miami and the state of Florida.
- * As container volume and cruise passenger volume grows, the demand for mid and high rise office, low-rise office and office/warehouse space will continue to increase. Warehouse space will feel the most pressure from this growth because of

the limited amount of land priced to justify this type of building. As demand for warehouse space increases, industrial land prices and rents for warehouse space will rise in tandem. As storage space becomes expensive relative to alternative locations, some storage will move to more rural areas and/or cargo volume will move to a port where storage is less expensive.

Miami can mitigate this situation by enhancing the distribution system and lowering the cost of ship cargo transfer. Enhancing the distribution of the existing infrastructure will lower land transportation cost, somewhat offsetting the rising storage cost, or allowing storage to be located further away from the port. Lowering the cost of ship cargo transfer, will again mitigate the rising cost of storage. A possibility for the cruise industry is a metro rail line from the airport to the seaport, creating a more efficient transfer of passengers (this is already planned for construction). Possibilities for the cargo industry include a direct access ramp from the port to I-95, and improved efficiency in cargo handling, port operations and port storage.

DATA DEFICIENCIES AND PROPOSAL FOR FUTURE WORK

An important link is established herein between seaport activities and commercial real estate in a metropolitan area. Other information in this area is extremely limited. The cause and effect relationships for the primary port activities are presented, as well as, the type of real estate required by seaport activities. Quantitative data on the actual demand caused by port activities is lacking due to the limited scope of this study. However, definitive examples are presented which provide certain quantitative rules of thumb and the logic behind establishing actual demand. Thus, this thesis offers the initial framework to study the demand that seaport activities have on commercial real estate in a metropolitan area.

Several key pieces of data are necessary to evolve this thesis from a general framework to a sophisticated relatively accurate real estate demand model. First, employment data, is required for each business sector involved with port activities. A major problem here is that employment in wholesale trade related to the port is difficult to obtain. The Standardized Industrial Codes (SIC) for a metropolitan area do not provide a breakdown of employees for importers and exporters. Furthermore, there is no data available on which importers and exporters are moving cargo through the seaport, as opposed to the airport, rail or trucks. However, depending on the type and destination of cargo, one might be able to estimate the amount of ocean borne

cargo as a percentage on total wholesale trade and then use this percentage to estimate employees related to seaport trade. The potential for error with this method is significant. An extensive survey of this business sector would probably reveal a substantially more accurate employment data base.

Assuming that employment can be determined for the wholesale trade sector related to the port, the next problem is determining the amount of storage space for importers and exporters. Remember, storage space requirements are basically dictated by cargo type, volume and destination. The author knows of no available data relative to general storage space requirements for cargo, let alone, by individual cargo type. There also is a data void on storage space requirements for vendors. These businesses are an important component of the port industry and demand a substantial amount of storage space. Again, an extensive survey of the space requirement relative to cargo type, volume and destination may generate the necessary data to construct a real estate demand model for a particular port.

In order to develop an accurate and useful model which determines the impact of seaport activities on demand for metropolitan commercial real estate, the author recommends six phases which are summarized below.

- (i) Complete an in-depth study of the Standard Metropolitan Statistical Area (SMSA) to determine the structural components and economic nuances (such as leakage) of the economy.
- (ii) Undertake an extensive survey of the employment and space needs of all port related activities in a metropolitan area, with special consideration for the wholesale trade and supply sectors (see Exhibit 5.1 for a survey example). Array the data in a meaning format such as suggested below.

SEAPORT ACTIVITIES	EMPLOYMENT	HIGH-RISE OFFICE	LOW-RISE OFFICE	OFFICE/ WAREHOUSE	WAREHOUSE	% OF TOTAL COMMERCIAL SPACE
Importers	5,000	-	-	750,000	2,000,000	
Exporter	4,700	-	-	705,000	1,500,000	
Cruise Line Co.	10,000	1,500,000	-	500,000	1,200,000	

Note: the above data is an example and does not relate to the Miami metropolitan area

- (iii) Prepare a disaggregation of the local economy by employment and space of the SMSA under study. At a minimum, a 32 x 32 business sector matrix should be established and multipliers should be determined to analyze the impact of seaport activities on metro commercial real estate in an expanding or contracting market.
- (iv) Further disaggregation of employment and space requirements for the wholesale trade SIC should be developed to separate importers and exporters that use the port for trade.

(v) Finally, for generation of realistic forecasts of demand for real estate from port activities, a structural time series model should be developed. This will statistically link port activities with historical demand, adjusting for any structural changes in the economy. The problem in this step will be generation of historical data, a momentous task.

Development of this model could be used to determine real estate demand by product type under scenarios of increased passenger or cargo volume. For example, the model could greatly assist the analyst in determining the amount of office space that is needed for the metro area if cruise passenger volume increases (say) 30% over the next five years.

It should be noted that the suggested model above does not consider the supply side of real estate. However, this component could be build into the structural model if the historical supply data is available.

SELECTED BIBLIOGRAPHY

REGIONAL ECONOMICS REFERENCES:

- Wheaton, William C. Area Wages, Unemployment, and Interregional Factor Mobility." Interregional Movements and Regional Growth (1979):1-11 & 237-251.
- Wheaton, William, Economics Professor. Real Estate Economics, Industrial Location, Notes from class lecture. Massachusetts Institute of Technology. May 1990.

ECONOMIC IMPACT REFERENCES

- Avrom Bendavid-val. 1983. "Regional and Local Economic Analysis for Practitioners." New and Expanded Edition. New York, NY: Praeger Publishers, pp. 33-64, 95-125.
- Polenske, Karen R. 1974. "Conceptual Input-Output Framework." Cambridge, MA: Department of Urban Studies and Planning, Massachusetts Institute of Technology, September 16.

PORT INDUSTRY REFERENCES:

- Frankel, Ernst. G. Port Planning and Development, John Wiley & Sons, Inc. 1987.
- U.S. Department of Commerce, Maritime Administration, Economic Impact of the U.S. Port Industry An Input-Output Analysis of Waterborne Transportation Volume 1. Analysis, prepared by Port Authority of New York and New Jersey, National Technical Information Services Publication no. PB-278 912 (April 1978)
- U.S. Department of Commerce, Maritime Administration, Office of Commercial Development & Office of Port and Intermodal Development, Port Economic Impact Kit, prepared by Arthur D. Little, Inc and Pacific Coast Association of Port Authorities, publication no. _____ (September 1979)

U.S. Department of Commerce, Maritime Administration, Office of Commercial Development & Office of Port and Intermodal Development, The Regional Port Impact Model Handbook Volume 2: Computer Package Users Guide, prepared by Port Authority of New York and New Jersey, National Technical Information Services Publication no. _____ (Summer 1982)

U.S. Department of Commerce, Maritime Administration, Office of Commercial Development & Office of Port and Intermodal Development, Port Economic Impact Kit, prepared by Temple, Barker & Sloane, Inc and Recht Haustath % Associates and Regional Science Research Institute, publication no. PB86-216959 (1985)

Martin Associates. The Economic Impact of The Port of Baltimore. Prepared for The Maryland Port Administration and the Greater Baltimore Committee. October 1987.

Martin O'Connell Associates, The Economic Impact of the Port of Houston. Prepared for the Port of Houston Authority. November 1987.

Yochum, Gilbert R., Ph.D and Agarwal, Vinod B., Ph.d. The Economic Impact and Rate of Return of Virginia's Port on the Commonwealth. College of Business & Public Administration, Old Dominion University. 1988.

WAREHOUSE & STORAGE REFERENCES

Peter Falconer and Jolyon Drury. Building and Planning for Industrial Storage and Distribution, The Architectural Press, London Halsted Press Division, John Wiley & Sons. 1975.

PORT OF MIAMI REFERENCES:

Dade County Economic Forum. Dade County Profile of Economic Growth, 1989. Dade County Economic Forum. 1989

Florida Department of Commerce, Division of Economic Development. The Florida Economy. Bureau of Economic Analysis. January 1987.

The Beacon Council, 1990 Miami/Dade County Profile. The Beacon Council Research Department. 1990.

INTERVIEWS WITH AUTHOR

- De Tuya, Oscar C. Jr. Vice President, Danzas Corporation (freight forwarder, freight consolidator and customs broker). Interview with author. Miami, Florida, June 1990.
- Di Gioia, Dave A. Research Analyst, Port of Miami. Interview with author. Miami, Florida, June 1990.
- Fernandez, Rick, Indio Service Corporation (cruise ship consulting). Telephone interview with author. July 1990.
- Hyatt, Jerry. Executive Vice President, Southern World Intl, Inc. (exporter of apparel and machine parts). Interview with author. Miami, Florida, June 1990.
- Jainarain, Charles I., Director of Research and Leis, Janet E., Senior Business Analyst, The Beacon Council (business promotion and research company). Interview with author. Miami, Florida, June 1990.
- Ortez, Ivan, President, United Tile Corporation (importers of ceramic floor tile). Telephone interview with author. July 17, 1990
- Macia, Jack, General Manager, Acoustical Distributors Inc, (importers of ceiling tile). Interview with author, Miami, Florida, June 1990.
- Rovirosa, Frank V. Vice President, Florida Stevedoring Inc. Interview with author. Miami, Florida, June 1990.
- Rodriguez-Vila, Fernando, Executive Vice President, Iberia Tiles (importer of floor tile). Telephone interview with author. July 1990.
- Valentine, John. President, Cypress Trading Company (importer and distributor of ceramic tiles). Interview with author. Miami, Florida, June 1990.

Exhibit 5.1

PORT INDUSTRY QUESTIONNAIRE
(ALL INFORMATION WILL BE HELD IN STRICT CONFIDENCE)

Company Name: _____
City: _____ Telephone: _____
Respondent Name: _____ Title: _____

- 1) Briefly Describe your waterborne commerce-related operations with the Port of Miami: _____

- 2) Is your Company an importer or exporter? _____
- 3) What specific type of products do you import or export?

- 4) How many employees are employed at your company? _____
- 5) How many square feet of office space and warehouse and other space do you rent or own?

Owned	Rented
Office Space: _____ sf	Office Space _____ sf
Warehouse Space: _____ sf	Warehouse space: _____ sf
Other Space: _____ sf	Other Space _____ sf
- 6) Do you feel your company needs more space, requires less space or has adequate space? _____

- 7) Is the company planning to expand its existing space? If so explain if the expansion is to meet current needs or anticipated future growth? _____

- 8) Where does the cargo come from (What Countries or states)? _____

- 9) Where is the final destination of cargo?

- 10) How much in short tons does your company import or export per year? _____

- 11) What is your company's average inventory turnover? _____

Exhibit 4.1
PORT OF MIAMI ECONOMIC IMPACT CALCULATIONS

ESTIMATED ECONOMIC IMPACT

MEDIA CONTACT: George W. Peters
Public Relations
2/8/90

*YEAR	CARGO TONNAGE	CARGO IMPACT	PASSENGERS	PASSENGER IMPACT	**OTHER IMPACT	TOTAL DIRECT IMPACT	***ESTIMATED TOTAL IMPACT	PORT REVENUES
1980	2,499,170	\$205,495,506	1,466,581	\$ 292,387,114	\$ 63.7m	\$ 561,562,359	\$1,403,905,897	\$ 9,533,461
1981	2,757,374	255,953,456	1,567,709	352,338,112	98.0m	706,248,711	1,765,621,777	10,339,907
1982	2,665,921	264,752,279	1,760,255	424,135,524	91.9m	780,810,455	1,952,026,137	11,867,619
1983	2,305,645	246,186,983	2,002,654	519,904,349	92.9m	859,030,758	2,147,576,895	14,201,008
1984	2,287,281	269,823,452	2,217,065	637,566,682	94.8m	1,004,125,854	2,510,314,635	15,943,548
1985	2,333,026	293,378,020	2,326,685	714,338,829	101.1m	1,108,804,693	2,772,011,733	17,135,048
1986	2,405,784	318,766,628	2,520,571	816,383,412	124.6m	1,259,722,841	3,149,307,102	18,223,415
1987	2,425,937	343,553,453	2,633,041	912,794,653	119.8m	1,376,165,700	3,440,414,250	19,933,197
1988	2,602,556	397,447,999	2,502,411	936,904,008	147.3m	1,481,672,248	3,704,180,620	26,489,275
1989	3,206,417	524,880,599	3,100,055	1,245,737,672	164.8m	1,935,420,918	4,838,552,295	30,035,859

* - Fiscal Year, Oct. 1 through Sept. 30
 ** - "Other Impact" includes salaries of those employed in direct port-related business, port operational expense and on-port Government agency expenses (Customs, Agriculture, etc.).
 *** - "Total Impact" is Direct Impact multiplied by an economic "ripple" factor of 2.5.

**Exhibit 3.1
CARGO CONTAINER EXAMPLES**

45' High Cube Dry Container

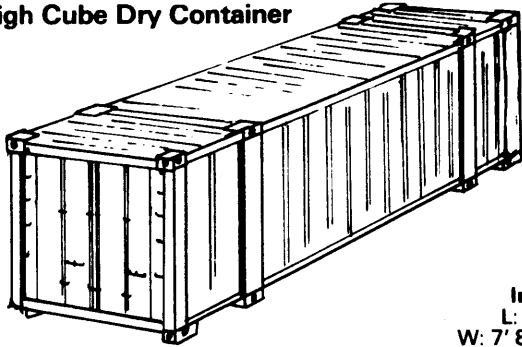

Cubic Cap.: 3,037 cu.ft. Payload: 62,655 lbs.

Interior
L: 44' 5"
W: 7' 8-1/2"
H: 8' 10"

40' Collapsible Flat Rack

Payload: 57,280 lbs.

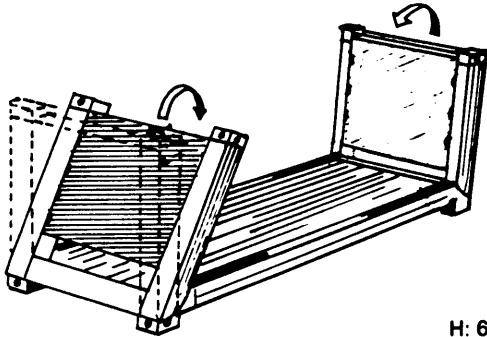

Interior
L: 39' 11"
W: 8'
H: 6' 6-3/16"

40' Platform

Payload: 86,000 lbs.

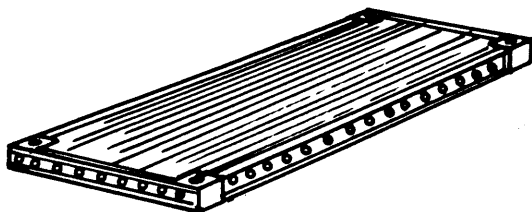

Interior
L: 40'
W: 8'

20' Tank Container

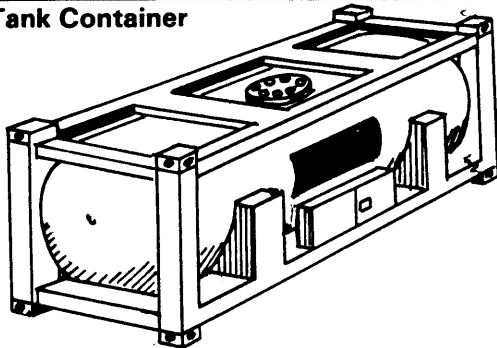

Cubic Cap.: 904 cu.ft. Payload: 6,764 U.S. Gals. H: 8' 6"

Exterior
L: 20'
W: 8'
H: 8' 6"

40' Reefer Container

Payload: 57,120 lbs.

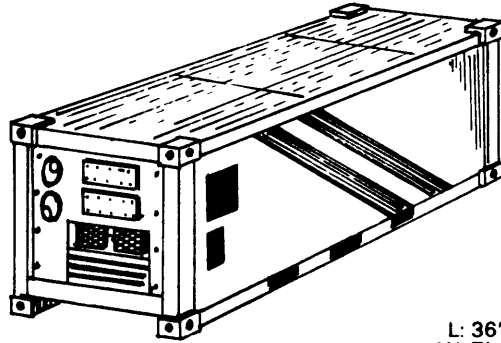

Cubic Cap.: 1,942 cu.ft.

Interior
L: 36' 9-1/4"
W: 7' 4-1/16"
H: 7' 2-1/4"

40' High Cube Reefer Container

Payload: 56,790 lbs.

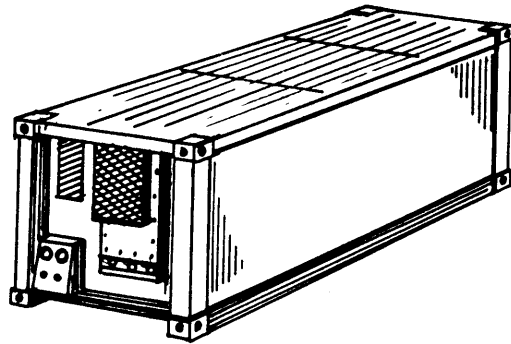

Cubic Cap.: 2,325 cu.ft.

Interior
L: 37' 11-13/16"
W: 7' 6"
H: 8' 2-1/16"

20' Reefer Container

Payload: 38,118 lbs.

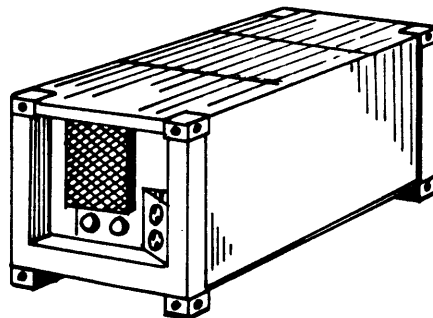

Cubic Cap.: 950 cu.ft.

Interior
L: 17' 10"
W: 7' 4-1/16"
H: 7' 3-1/4"

Exhibit 3.2
CONTAINER SHIPS AT THE PORT OF MIAMI

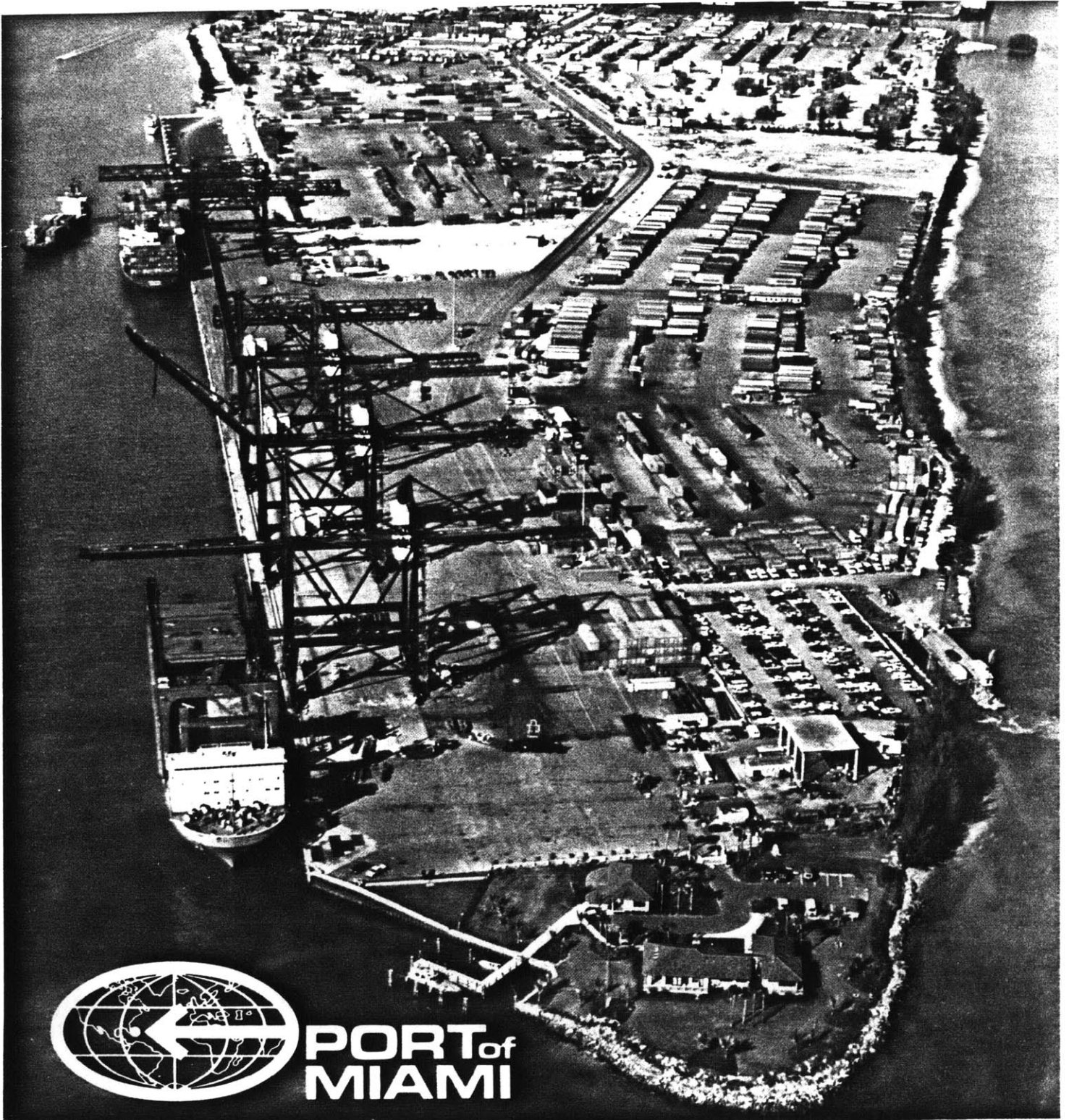

Exhibit 3.3
RO-RO CARGO AT THE PORT OF MIAMI



Gateport • Port of Miami • Winter 1990