



**EVALUATING THE DEPICTION OF COMPLEX RNAV/RNP
PROCEDURES AND ANALYZING A POTENTIAL DE-
CLUTTERING TECHNIQUE**

Abhizna Butchibabu and R. John Hansman

*This report is based on the S.M. Thesis of Abhizna Butchibabu submitted to
the Department of Aeronautics and Astronautics
in partial fulfillment of the requirements for the degree of
Master of Science in Aeronautics and Astronautics*

Report No. ICAT-2012-3
May 2012

MIT International Center for Air Transportation (ICAT)
Department of Aeronautics & Astronautics
Massachusetts Institute of Technology
Cambridge, MA 02139 USA

[Page Intentionally Left Blank]

EVALUATING THE DEPICTION OF COMPLEX RNAV/RNP PROCEDURES AND ANALYZING A POTENTIAL DE-CLUTTERING TECHNIQUE

by

Abhizna Butchibabu and Prof. R. John Hansman

ABSTRACT

Performance Based Navigation (PBN) is a key element of the Federal Aviation Administration's (FAA) NextGen Program. In order to increase National Airspace System (NAS) capacity and efficiency, PBN routes and procedures are being developed, including Area Navigation (RNAV) and Required Navigation Performance (RNP) procedures. RNAV enables aircraft to fly directly from point-to-point on any desired flight path using ground- or spaced-based navigation aids. RNP is RNAV with the addition of onboard monitoring and alerting capability. Both RNAV and RNP procedures allow aircraft to fly accurate routes without relying on ground-based navigation aids. RNAV and RNP procedures facilitate more efficient design of airspace and procedures, offering significant safety improvements and flexibility to negotiate terrain, as well as improving airspace capacity and operational efficiency.

The initial implementation of RNAV and RNAV (RNP) procedures has raised several human factors issues. RNAV (RNP) Instrument Approach Procedures (IAP) and RNAV Standard Instrument Departures (SID) and Standard Terminal Arrivals (STARs) often have more waypoints, altitude constraints and other elements than conventional procedures, resulting in charts being cartographically complex. Thus, a chart review was conducted to objectively understand the procedure elements that contributed to increased information density and high levels of visual clutter.

A total of sixty-three approach, fifty-two departure, and fifty-four arrival procedures were analyzed. Primary findings were that the factors associated with high levels of visual clutter included having multiple flight paths per page for approach and departure procedures, and having complex altitude constraints for arrival procedures. Multiple waypoints per path was also a factor for both arrivals and approaches. In addition, having RF legs were additional factor contributing to visual clutter for approach procedures.

One method to mitigate the increased information density and visual clutter on the RNAV and RNP procedure depiction is to reduce the number of flight paths shown on a single page by separating the depicted paths to multiple pages. However, there are a number of drawbacks to

this clutter mitigation technique. Example drawbacks include having more paper to carry in the flight deck and more time spent searching for the correct page within a set of separated pages.

An experiment was conducted to determine the effect of reducing the number of paths depicted on single-page “Modified” charts. FAA AeroNav Products and Jeppesen created versions of the Modified chart in their standard cartographical conventions. The experiment was conducted to evaluate whether these Modified charts would impact information retrieval time and accuracy compared with the “Current” charts being used now. Current FAA AeroNav Products and Jeppesen charts were used as the baseline condition. Six procedures were studied, including three RNAV departure procedures from Dallas/Fort Worth, Las Vegas, and Salt Lake City airports, and three RNAV (RNP) approach procedures from Boise, Bozeman, and Palm Springs airports. During the experiment, pilots were shown the same procedure in Current and Modified chart formats.

All charts were displayed electronically on a high-resolution computer monitor. Pilots were asked information retrieval questions associated with each chart. Pilot response time and accuracy with which pilots answered the information retrieval questions were recorded. Pilots completed the task in two blocks, one for approaches and one for departures. The Current and Modified charts within each block were presented in random order, and the order of the two blocks was counterbalanced. Each block began with six practice questions. Each session took approximately one hour to complete.

Data were collected from 28 commercial airline pilots and 19 corporate pilots with average flight experience of 11,484 hours. Fourteen pilots used FAA AeroNav charts, and 33 pilots used Jeppesen charts.

Pilots were found to answer questions faster using Modified charts than Current charts. This effect was statistically significant with a p-value less than 0.01. For approach procedures, the mean response time for Current charts was 16.9 seconds, compared with 10.6 seconds for Modified charts. For departure procedures, the mean response time for Current charts was 16.2 seconds, compared with 13.2 seconds for Modified charts. Response times were also significantly faster for Modified charts than for Current charts when analyzed for each airport, chart manufacturer (Jeppesen and FAA AeroNav Products), and pilot type (Corporate and Airline).

Overall question response accuracy for all 47 participants was 99.5%. There were no statistically significant differences found for the response accuracy between Modified and Current chart use.

ACKNOWLEDGEMENTS

This project was funded by the Federal Aviation Administration (FAA) Human Factors Research and Engineering Division (ANG-C1) and US DOT Volpe Center with support from the FAA's Aviation Safety (AVS) and Flight Standards (AFS-470) divisions under the grant No. DTR57-07-D-30006.

Abhizna Butchibabu was supported by an Avidyne Fellowship funded by Dan Schwinn for much of this work.

The work presented in this report was completed in collaboration with Divya Chandra, Rebecca Grayhem, Andrew Kendra, and Alan Midkiff. Valuable guidance and support was received from Tom McCloy, Dan Herschler, Kathy Abbott and Mark Steinbicker. The instrument procedure charts presented in the work were developed in collaboration with FAA AeroNav Products and Jeppesen chart manufacturers, including John Moore, Valerie Watson, Brad Rush, Ted Thompson, and Jeff Williams. Numerous professional pilots' participation in the study greatly contributed to this work.

Table of Contents

List of Figures	8
List of Tables	10
Acronyms	11
Chapter 1. Introduction	13
1.1 Motivation	16
1.2 Research Overview	17
Chapter 2. Background	19
2.1 Current Depiction of Instrument Procedures	20
<i>2.1.1 RNAV (RNP) Approach Charts</i>	<i>21</i>
<i>2.1.2 RNAV Standard Instrument Departure (SID) Charts</i>	<i>26</i>
<i>2.1.3 RNAV Standard Terminal Arrival (STAR) Charts</i>	<i>31</i>
<i>2.1.4 Chart Manufacturers</i>	<i>35</i>
2.2 Previous Studies on Chart Design	41
2.3 Analysis of Safety Reports Related to RNAV and RNP Procedures	43
2.3.1 Method	43
2.3.2 Results.....	44
2.4 Summary	47
Chapter 3. RNAV and RNP Chart Review	48
3.1 Method	48
3.2 Approach Procedures	49
3.2.1 Overview	49
3.2.2 Results.....	52
3.3 Departure Procedures	60
3.3.1 Overview	60
3.3.2 Results.....	62
3.4 Arrival Procedures	65
3.4.1 Overview	65
3.4.2 Results.....	67
3.5 Summary and Conclusions of Chart Review	71

Chapter 4. Experiment Design of Separating Trajectories Across Multiple Pages	72
4.1 Introduction.....	72
4.2 Multipage Modified Charts.....	77
4.3 Information Retrieval Task	81
4.3.1 Information Retrieval Question	86
4.4 Study Protocol.....	88
Chapter 5. Experiment Results and Discussion	90
5.1 Participants.....	90
5.2 Accuracy	92
5.3 Response Time.....	92
5.3.1. Effect of Chart Manufacturer Type	93
5.3.2. Effect of Airport.....	95
5.3.3. Effect of Pilot Type.....	97
5.3.4. Effect of Question Type.....	98
5.3.5 Detailed Evaluation of Question Type Analysis	100
5.5 Subjective Feedback.....	104
Chapter 6. Summary and Conclusion	105
6.1. Summary.....	105
6.2 Conclusion	108

List of Figures

FIGURE 1. RNAV AND RNP ROUTES COMPARED WITH CONVENTIONAL ROUTES. (SOURCE: FAA)	13
FIGURE 2. THE PLANVIEW OF APPROACH CHARTS AT DEKALB-PEACHTREE AIRPORT (PDK) INTO RUNWAY 22L (A) CONVENTIONAL ILS PROCEDURE (B) RNAV (GPS) ROUTES AND (C) RNAV (RNP) ROUTES.....	14
FIGURE 3. RNAV AND RNP PROCEDURES AVAILABILITY FOR EACH PHASE OF FLIGHT [PROFESSIONAL PILOT MAGAZINE, 2010]	19
FIGURE 4. RNAV (RNP) Z RWY 20L, PDK AIRPORT, ATLANTA, GA AS AN EXAMPLE OF RNAV (RNP) APPROACH PROCEDURE.....	21
FIGURE 5. ILLUSTRATION OF THE APPROACH SEGMENTS AND TRANSITION FIXES [FAA-H-9261-1A].....	22
FIGURE 6. AN EXAMPLE OF CONVENTIONAL APPROACH PROCEDURE (A) AND RNP AR APPROACH PROCEDURE (B) IS SHOWN.	24
FIGURE 7. SHEAD SEVEN DEPARTURE, LAS VEGAS, NEVADA, SHOWN AS AN EXAMPLE OF AN RNAV SID.	28
FIGURE 8. AN EXAMPLE OF A CONVENTIONAL SID FROM LAS VEGAS AIRPORT	30
FIGURE 9. KRANN ONE ARRIVAL, BOSTON, MASSACHUSETTS, SHOWN AS AN EXAMPLE OF AN RNAV STAR.	32
FIGURE 10. AN EXAMPLE OF CONVENTIONAL STAR AT BOSTON LOGAN AIRPORT	34
FIGURE 11. AN EXAMPLE OF JEPPESEN IAP CHART INTO BOZEMAN AIRPORT	37
FIGURE 12. AN EXAMPLE OF FAA IAP CHART INTO BOZEMAN AIRPORT.....	38
FIGURE 13. AN EXAMPLE OF JEPPESEN SID CHART INTO LAS VEGAS AIRPORT.....	39
FIGURE 14. AN EXAMPLE OF FAA AERONAV PRODUCTS SID CHART INTO LAS VEGAS AIRPORT.....	40
FIGURE 15. DEVIATIONS REPORTED FOR EACH PROCEDURE TYPE	45
FIGURE 16. RECURRING ISSUES IDENTIFIED FOR RNAV DEPARTURE PROCEDURES	46
FIGURE 17. RECURRING ISSUES IDENTIFIED FOR RNAV ARRIVAL PROCEDURES	46
FIGURE 18. EXAMPLE RNAV (RNP) APPROACH PROCEDURE FOR BOI INTO RUNWAY 28L	51
FIGURE 19. LIST OF PROCEDURE ELEMENTS COMPARING APPROACHES AT BASELINE AIRPORTS AND PROBLEMATIC AIRPORTS A) SHOWS THE AVERAGE NUMBER OF PROCEDURE ELEMENTS B) SHOWS THE PROCEDURE ELEMENTS RELATED TO DISTANCE	53
FIGURE 20. AVERAGE NUMBER OF PATHS SHOWN FOR INDIVIDUAL AIRPORTS CATEGORIZED BY BASELINE AND PROBLEMATIC.....	54
FIGURE 21. VERTICAL PROFILE STARTING FIX IS SHOWN FOR INDIVIDUAL AIRPORT CATEGORIZED BY PROBLEMATIC GROUP AND BASELINE GROUP. THE SHADED REGION SHOWS THE RANGE OF PROFILE VIEWS AT THE AIRPORT..	55
FIGURE 22. AVERAGE NUMBER OF WAYPOINTS PER PATH FROM IAF TO MAP PER AIRPORT IS SHOWN FOR BASELINE AND PROBLEMATIC AIRPORTS.	56
FIGURE 23. AVERAGE NUMBER OF RF LEGS PER PATH ARE SHOWN FOR INDIVIDUAL BASELINE AND PROBLEMATIC AIRPORTS	57
FIGURE 24. AVERAGE NUMBER OF WAYPOINTS IN THE MISSED APPROACH PROCEDURE IS SHOWN FOR INDIVIDUAL AIRPORTS CATEGORIZED BY BASELINE AND PROBLEMATIC	58
FIGURE 25. AVERAGE NUMBER OF RF LEGS IN MISSED APPROACH COURSE IS SHOWN FOR INDIVIDUAL AIRPORTS CATEGORIZED BY BASELINE AND PROBLEMATIC	58
FIGURE 26. AVERAGE NUMBER OF WAYPOINTS BETWEEN IF AND FAF PER PROCEDURE IS SHOWN FOR INDIVIDUAL AIRPORTS CATEGORIZED BY BASELINE AND PROBLEMATIC	59
FIGURE 27. EXAMPLE RNAV DEPARTURE PROCEDURE AT ATLANTA AIRPORT	61

FIGURE 28. LIST OF PROCEDURE ELEMENTS COMPARING DEPARTURES AT BASELINE AIRPORTS AND PROBLEMATIC AIRPORTS A) SHOWS THE AVERAGE NUMBER OF PROCEDURE ELEMENTS B) AND C) SHOWS THE PROCEDURE ELEMENTS RELATED TO DISTANCE	63
FIGURE 30. LEETZ TWO RNAV DEPARTURE AT SLC.....	64
FIGURE 29. AVERAGE NUMBER OF PATHS PER PROCEDURES IS SHOWN FOR EACH AIRPORT CATEGORIZED BY BASELINE AND PROBLEMATIC.	64
FIGURE 31. ELDEE FIVE RNAV ARRIVAL AT DCA.....	66
FIGURE 32. . LIST OF CHART ELEMENTS REVIEWED FOR ARRIVALS COMPARING BASELINE GROUP WITH PROBLEMATIC GROUP A) SHOWS THE AVERAGE NUMBER OF PROCEDURE ELEMENTS B) AND C) SHOW THE PROCEDURE ELEMENTS RELATED TO DISTANCE	68
FIGURE 33. AVERAGE NUMBER OF ALTITUDE CONSTRAINTS PER PATH IS SHOWN FOR EACH AIRPORT CATEGORIZED BY BASELINE AND PROBLEMATIC.....	69
FIGURE 34. AVERAGE NUMBER OF NON-CONSTRAINED ALTITUDES PER PATH IS SHOWN FOR EACH AIRPORT CATEGORIZED BY BASELINE AND PROBLEMATIC.	70
FIGURE 35. AVERAGE NUMBER OF WAYPOINTS PER PATH FOR ARRIVAL PROCEDURES IS SHOWN FOR EACH AIRPORT IN THE PROBLEMATIC AND BASELINE GROUP	70
FIGURE 36. EXAMPLE APPROACH CHARTS (A) CURRENT CHART (B) MODIFIED CHART	73
FIGURE 37. EXAMPLE DEPARTURE PROCEDURE (A) CURRENT CHART (B) MODIFIED CHART.	74
FIGURE 38. AN EXAMPLE OF MODIFIED APPROACH CHART FOR RNAV(RNP) Z RWY 28L, BOISE AIRPORT	75
FIGURE 39. AN EXAMPLE OF MODIFIED CHARTS FOR THE GRAPHICAL PAGE OF LEETZ TWO DEPARTURE, SALT LAKE CITY AIRPORT	76
FIGURE 40. EXAMPLE JEPPESEN APPROACH PROCEDURES (A) CURRENT CHART (B) MODIFIED CHART	78
FIGURE 41. EXAMPLE JEPPESEN DEPARTURE PROCEDURES (A) CURRENT CHART (B) MODIFIED CHART.....	79
FIGURE 42. AN ANNOTATED EXAMPLE SCREENSHOT OF THE EXPERIMENT DISPLAY.....	82
FIGURE 43. FLOW DIAGRAM OF EACH TRIAL	83
FIGURE 44. AN EXAMPLE SCREENSHOT OF THE EXPERIMENT DISPLAY FROM THE BEGINNING OF A TRIAL IS SHOWN, WHERE A CLEARANCE AND QUESTION IS SHOWN TO THE PILOT WITHOUT THE CHART.	84
FIGURE 45. AN EXAMPLE SCREENSHOT OF EXPERIMENT DISPLAY AFTER "CHART" BUTTON IS CLICKED IS SHOWN. PILOTS ARE PRESENTED WITH THE CHART ALONG WITH THE CLEARANCE AND QUESTION.	84
FIGURE 46. AN EXAMPLE SCREENSHOT OF EXPERIMENT DISPLAY AFTER "ANSWER QUESTION" BUTTON IS CLICKED IS SHOWN. PILOTS ARE SHOWN A GRAYED-OUT CHART AND AN INPUT TEXT BOX ALONG WITH THE CLEARANCE AND QUESTION.....	85
FIGURE 47. FLOW DIAGRAM OF THE STUDY PROTOCOL.....	89
FIGURE 48. COMFORT LEVEL FOR RNAV (RNP) APPROACHES AND RNAV DEPARTURES RATED BY PARTICIPANTS ON A SCALE OF 1 (LOW) TO 5 (HIGH).....	91
FIGURE 49. AVERAGE RESPONSE TIMES FOR CURRENT AND MODIFIED CHARTS FOR EACH PROCEDURE TYPE.....	93
FIGURE 50. AVERAGE RESPONSE TIMES FOR CURRENT AND MODIFIED CHARTS FOR EACH CHART MANUFACTURER TYPE.....	94
FIGURE 51. AVERAGE RESPONSE TIMES FOR CURRENT AND MODIFIED CHARTS FOR EACH AIRPORT TESTED IN THE STUDY.....	96
FIGURE 52. AVERAGE RESPONSE TIMES FOR CURRENT AND MODIFIED CHARTS FOR EACH PILOT TYPE.....	97
FIGURE 53. AVERAGE RESPONSE TIMES FOR CURRENT AND MODIFIED CHARTS FOR EACH QUESTION TYPE.	99
FIGURE 54. AVERAGE RESPONSE TIMES FOR EACH PATH-SPECIFIC QUESTIONS FOR APPROACHES.	101
FIGURE 55. AVERAGE RESPONSE TIMES FOR EACH PATH-SPECIFIC QUESTIONS FOR DEPARTURES.	102
FIGURE 56. AVERAGE RESPONSE TIMES FOR EACH GENERAL QUESTION TYPE FOR APPROACHES.....	103

List of Tables

TABLE 1. LIST OF PROCEDURE VARIABLES USED FOR APPROACH PROCEDURES IN THE CHART REVIEW	50
TABLE 2. DATA SAMPLE FOR AN EXAMPLE APPROACH PROCEDURE	50
TABLE 3. LIST OF AIRPORTS ANALYZED FOR APPROACH PROCEDURES	52
TABLE 4. LIST OF PROCEDURE VARIABLES USED FOR DEPARTURE PROCEDURES IN THE CHART REVIEW	60
TABLE 5. DATA SAMPLE FOR AN EXAMPLE DEPARTURE PROCEDURE.....	60
TABLE 6. LIST OF AIRPORTS ANALYZED FOR DEPARTURE PROCEDURES	62
TABLE 7. LIST OF PROCEDURE VARIABLES USED FOR ARRIVAL PROCEDURES IN THE CHART REVIEW	65
TABLE 8. DATA SAMPLE FOR AN EXAMPLE DEPARTURE PROCEDURE.....	66
TABLE 9. LIST OF AIRPORTS ANALYZED FOR ARRIVAL PROCEDURES	67
TABLE 10. LIST OF PROCEDURES TESTED AND THE NUMBER OF PAGES IN MODIFIED CHARTS COMPARED TO CURRENT CHARTS.....	80
TABLE 11. SAMPLE QUESTIONS FOR APPROACH PROCEDURE INTO BOISE AIRPORT.	86
TABLE 12. SAMPLE QUESTIONS FOR DEPARTURE PROCEDURE OUT OF LAS VEGAS AIRPORT.....	87
TABLE 13. PARTICIPANT’S EXPERIENCE AND BACKGROUND	90
TABLE 14. PARTICIPANTS’ FLIGHT EXPERIENCE AT THE AIRPORTS FROM WHICH THE PROCEDURES WERE SELECTED FOR THE EXPERIMENT.....	92
TABLE 15. STATISTICS FOR EACH PROCEDURE TYPE COMPARING CURRENT AND MODIFIED CHARTS.	93
TABLE 16. STATISTICS FOR EACH CHART MANUFACTURER TYPE COMPARING CURRENT AND MODIFIED CHARTS.	95
TABLE 17. STATISTICS FOR EACH AIRPORT COMPARING CURRENT AND MODIFIED CHARTS.	96
TABLE 18. STATISTICS FOR EACH PILOT TYPE COMPARING CURRENT AND MODIFIED CHARTS.	97
TABLE 19. STATISTICS FOR EACH QUESTION TYPE COMPARING CURRENT AND MODIFIED CHARTS.....	100
TABLE 20. STATISTICS FOR EACH PATH-SPECIFIC QUESTION TYPE COMPARING CURRENT AND MODIFIED APPROACH CHARTS.....	101
TABLE 21. STATISTICS FOR EACH PATH-SPECIFIC QUESTION TYPE COMPARING CURRENT AND MODIFIED DEPARTURE CHARTS.....	102
TABLE 22. STATISTICS FOR EACH GENERAL QUESTION TYPE COMPARING CURRENT AND MODIFIED APPROACH CHARTS.	103

Acronyms

AC	Advisory Circular
ACF	Aeronautical Charting Forum
AFS	FAA Flight Standards Service
AGL	Above Ground Level
ALPA	Air Line Pilots Association
AR	Authorization Required
ASRS	Aviation Safety Reporting System
ATC	Air Traffic Control
ATL	Atlanta International Airport, Georgia
AVN	Aviation Standards National Field Office
BOI	Boise Air Terminal, Idaho
BWI	Baltimore/Washington International Airport, Maryland
BZN	Bozeman Airport, Montana
CAASD	Center for Advanced Aviation Systems Development
CDA	Continuous Descent Approach
CFIT	Controlled Flight into Terrain
CFR	Code of Federal Regulations
CLT	Charlotte/Douglas International Airport, North Carolina
CVG	Cincinnati/Covington International Airport, Ohio
DC	District of Columbia
DCA	Reagan Washington National Airport, District of Columbia
DFW	Dallas/Fort Worth International Airport, Texas
DME	Distance Measuring Equipment
EWR	Newark International Airport, New Jersey
FAA	Federal Aviation Administration
FAF	Final Approach Fix
FLL	Fort Lauderdale/Hollywood International Airport, Florida
FMC	Flight Management Computer
FMS	Flight Management System
GPS	Global Positioning Satellite
IAD	Dulles Airport, Virginia
IAF	Initial Approach Fix
IAH	George Bush Houston Intercontinental Airport, Texas
IAP	Instrument Approach Procedure
IAPA	Instrument Approach Procedure Automation
ICAO	International Civil Aviation Organization
IPDS	Instrument Procedure Development System
IF	Intermediate Fix
IFR	Instrument Flight Rules
ILS	Instrument Landing System
IFK	John F. Kennedy New York International Airport, New York
L	Left
LAS	Las Vegas International Airport, Nevada
LAX	Los Angeles International Airport, California
LGA	La Guardia New York Airport, New York
LGB	Long Beach Airport, California
LOC	Localizer

LWS	Lewiston-Nez Perce County Airport, Idaho
MAP	Missed Approach Point
MCO	Orlando International Airport, Florida
MEA	Minimum En Route Altitude
MIA	Miami International Airport, Florida
MIT	Massachusetts Institute of Technology
MOCA	Minimum Obstacle Clearance Altitude
MSP	Minneapolis-St. Paul International Airport, Minnesota
NAS	National Airspace System
NASA	National Aeronautics and Space Administration
NBAA	National Business Aviation Association
NextGen	Next Generation Air Transportation System
NM	Nautical mile
OEP	Operational Evolution Partnership
PARC	Performance Based Operations Aviation Rulemaking Committee
PBI	Palm Beach International Airport, Florida
PBN	Performance Based Navigation
PDK	Dekalb-Peachtree Airport, near Atlanta, Georgia
PDX	Portland International Airport, Oregon
PHL	Philadelphia International Airport, Pennsylvania
PHX	Phoenix Sky Harbor International Airport, Arizona
PSP	Palm Springs International Airport, California
R	Right
RDU	Raleigh-Durham International Airport
RF	Radius-to-fix
RIL	Rifle Regional Airport, Colorado
RNAV	Area Navigation
RNP	Required Navigation Performance
RWY	Runway
SAAAR	Special Aircraft Aircrew Authorization Required
SAN	San Diego International Airport, California
SEA	Seattle-Tacoma International Airport, Washington
SDL	Scottsdale Airport, Arizona
SLC	Salt Lake City International Airport, Utah
SFO	San Francisco International Airport, California
SID	Standard Instrument Departure
SME	Subject Matter Expert
SNA	Santa Ana/Orange County Airport, California
STAR	Standard Terminal Arrival
TEB	Teterboro Airport, New Jersey
TERPS	Terminal Instrument Procedures
TPA	Tampa International Airport, Florida
US	United States
USDOT	United States Department of Transportation
VHF	Very High Frequency
VNTSC	Volpe National Transportation System Center
VOR	VHF Omni-directional Range

Chapter 1

Introduction

The Federal Aviation Administration (FAA) and International Civil Aviation Organization (ICAO) are transitioning to Performance-Based Navigation (PBN) airspace, in order to increase National Airspace System (NAS) capacity and efficiency. PBN routes and procedures, which include Area Navigation (RNAV) and Required Navigation Performance (RNP) procedures, are being developed in order to help achieve this transition [MITRE CAASD, 2010]. RNAV and RNP procedures are designed to take advantage of the advanced navigation technology. RNAV enables aircraft to fly directly from point-to-point on any desired flight path using ground- or spaced-based navigation aids. RNP is RNAV with the addition of onboard monitoring and alerting capability. RNP procedures meet specific requirements for position determination and track conformance, enabling the aircraft to fly accurate routes without flying directly over ground-based navigation aids.

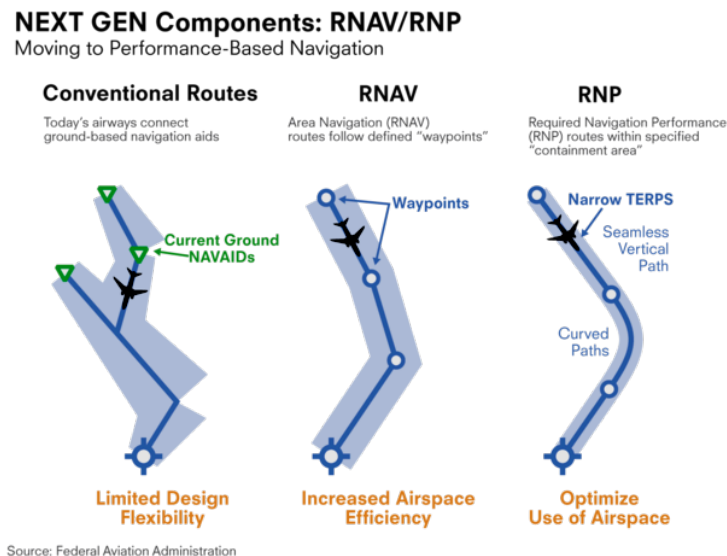

Figure 1. RNAV and RNP routes compared with conventional routes. (Source: FAA)

Figure 1 illustrates different routes from conventional to RNAV to RNP procedures. As seen from the figure, RNAV and RNP procedures facilitate more efficient design of airspace and procedures. They offer operators significant safety improvements, and new levels of flexibility to negotiate terrain, access to airspace, airspace capacity and operational efficiency.

However, the initial implementation of RNAV and RNAV (RNP) procedures has raised several human factors issues. RNAV Standard Instrument Departures (SIDs) and Standard Terminal Arrivals (STARs) and RNAV (RNP) Instrument Approach Procedures (IAPs) often have more waypoints, altitude constraints and other elements than conventional procedures, resulting in charts being cartographically complex.

Figure 2 shows example planviews of conventional, RNAV and RNP IAPs from Peachtree Dekalb Airport (PDK) in Atlanta, GA, into runway 22L. The planviews shown in this figure map one-to-one to Figure 1.

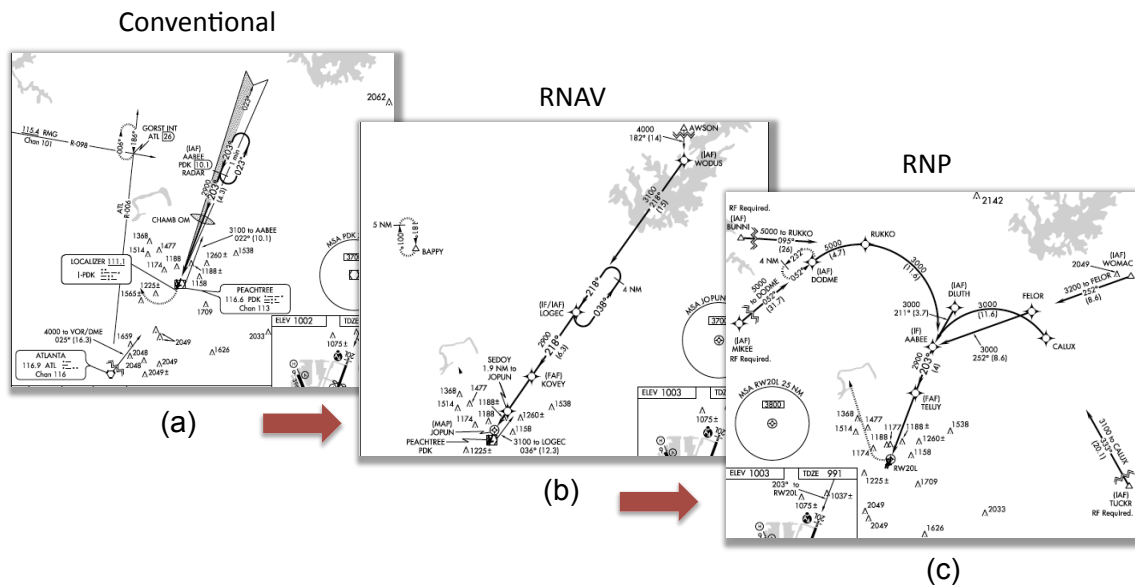

Figure 2. The planview of approach charts at DeKalb-Peachtree airport (PDK) into runway 22L (a) Conventional ILS procedure (b) RNAV (GPS) routes and (c) RNAV (RNP) routes.

Figure 2(a) shows an Instrument Landing System (ILS) procedure as an example of conventional IAP. ILS procedure utilizes ground-based navigation aids that transmit radio waves in one particular direction from the airport. This procedure is typically one straight-line path that allows the aircraft to approach and land at the airport as shown in Figure 2(a). Unlike ILS procedures, where the path followed is conical and the existence of the ground-based signals only exists within that cone, RNAV procedures (Figure 2(b)) utilizes spaced-based navigation aid that allow for greater airspace efficiency with its constant width paths.

Finally, Figure 2(c) represents an example of RNAV (RNP) approach procedure. As seen from the figure, RNAV (RNP) procedures contain strictly defined paths that are typically constructed using curved segments called Radius-to-Fix (RF) legs. In addition, complex RNP procedures can typically contain multiple paths. In Figure 2(c), there are a total of 5 paths beginning from fixes: MIKEE, BUNNI, DLUTH, WOMAC, and TUCKR. The combination of multiple paths and RF legs can create a graphical representation on the RNAV (RNP) procedures that is vastly different from the conventional procedures such as ILS procedures.

The implementation of RNAV and RNP procedures has already begun. Alaska Airlines developed the first RNAV (RNP) approach procedure into Juneau, Alaska in 1996. Since then, over 136 RNAV (RNP) procedures have been developed and deployed in the United States' at the top 50 NAS airports (by operation) alone [MITRE CAASD, 2011]. There are over 600 RNAV and RNP procedures developed in the United States as of 2010 [US DOT AV-2011-025, 2010].

Along with increase in operational safety and the efficient usage of airspace, the utilization of RNAV (RNP) approach procedures has already produced substantial benefits in terms of fuel savings. For example, Southwest Airlines, who has reportedly flown over 5,800 RNP IAP operations, is saving more than \$1 million per month in fuel costs by utilizing the RNP capability [Aviation Week & Space Technology, 2011]. Alaska Airlines who has flown total of 39,700 RNP IAP operations as of 2007 has reportedly saved \$8 million [Honeywell, 2007]. Due to these benefits already being observed, many more RNAV (RNP) procedures are planned to be developed in the next few years [MITRE CAASD, 2011].

Currently in the United States, there are specific requirements that need to be met in order to fly the RNAV (RNP) IAPs. These requirements include special training for flight crew and

specific equipment standards for the aircraft. In order to make pilots and ATC aware of this requirement, it is charted on RNAV (RNP) approach procedures as “Authorization Required” (AR) on the RNAV (RNP) IAP procedures [FAA Order 8260.52]. This authorization was previously referred to and charted as ‘Special Aircraft Aircrew Airworthiness Authorization’ (SAAAR) now shortened to Authorization Required (AR).

1.1 Motivation

Currently, there is limited human factors research available regarding the depiction of advanced PBN procedures. This is primarily due to the short time these procedures have been in place. One document published in 2006 by NASA Langley included a list of chart depiction issues associated with RNAV Standard Instrument Departures (SIDs) and RNAV Standard Terminal Arrivals (STARs). The authors, based on attendance at formal industry group meetings and discussions with subject matter experts, identified chart clutter and high levels of information density contributing to human factors issues such as high heads-down search time, workload, and waypoint confusion [Barhydt et al., 2006a].

Barhydt and Adams also conducted a review of 124 safety reports from the Aviation Safety Reporting System (ASRS) database associated with RNAV SIDs and STARs. These reports were filed between 2000 and mid-2005. The authors found that approximately 30% of the issues encountered by pilots were due to chart and procedure design. Barhydt and Adams listed chart clutter, waypoint proximity on charts, and use of waypoints by pilots as examples of chart and procedure design issues [Barhydt et al., 2006b].

Butchibabu, Midkiff, Kendra, Hansman and Chandra (2010) updated the ASRS review conducted by Barhydt and Adams by examining reports filed between January 2004 and April 2009. The published report is presented in Appendix A. Butchibabu et al. found that approximately 28% of 202 ASRS reports associated with RNAV SIDs and 30% of 69 ASRS reports associated with RNAV STARs were related to procedure and chart design issues [Butchibabu et al., 2010]. This finding is further explained in Section 2.3.

Barhydt et al (2006b) and Butchibabu et al. (2010) have emphasized the need for further human factors research regarding specific charting issues contributing to these safety

reports. Additionally, Barhydt and Adams (2006a) also emphasized the need for chart design guidelines for these advanced PBN procedures.

In addition to these documented studies, issues regarding the depiction of RNAV (RNP) IAPs have also been identified within industry technical and operational committees such as the Aeronautical Charting Forum (ACF) and the Performance Based Operations Aviation Rulemaking Committee (PARC) RNP Charting Working Group (WG). The ACF is an FAA and AeroNav Products led group, which identifies charting issues and provides recommendation for criteria, design and development policies for instrument procedures. The PARC Charting WG is tasked by the FAA to provide a set of recommendations to improve operational usability of PBN instrument procedure charts. Both groups include subject matter experts from pilots, ATC, chart manufacturers, and procedure designers.

ACF and PARC identified concerns over high information density and clutter for the newly implemented RNAV (RNP) AR IAPs [FAA 09-02-220, 2009]. Some of these complex IAPs have multiple Initial Approach Fixes (IAFs) and multiple Intermediate Fixes (IFs), defining several paths to the runway with curved segments. Also, due to the multiple IF segments, it becomes complicated, and often not possible, to depict all of the different vertical profiles in one view [PARC RNP Charting WG, 2010]. This is further illustrated and discussed in Chapter 2, Section 2.1.

1.2 Research Overview

In order to evaluate the identified human factors concerns of RNAV and RNP procedures, the research presented in this thesis aims to achieve two objectives:

- 1) Evaluate the depiction of RNAV departures and arrivals and RNAV (RNP) approach charts for procedure elements that contribute to operational usability issues.
- 2) Investigate potential techniques to reduce clutter.

In order to address the proposed research objective 1, a chart review was conducted on two sets of RNAV and RNP procedures. One set of “Problematic” RNAV (RNP) IAPs, RNAV SIDs and RNAV STARs were identified based on the operational safety reports obtained through

the Aviation Safety Reporting System (ASRS)¹ and the input from industry technical and operational committees such as the ACF and the PARC RNP Charting WG. The second set was identified as the “Baseline” Group, which consisted of procedures from the top 35 OEP airports that were not included in the Problematic set. For the review, an analysis of procedural elements that were depicted on the charts was completed. Both identified sets of charts were reviewed and compared.

Primary findings were that the factors associated with high levels of visual clutter included having multiple flight paths per page for approach and departure procedures, and having complex altitude constraints for arrival procedures. Multiple waypoints per path was also a factor for both arrival and approach procedures. In addition, having RF legs contributed to visual clutter for approach procedures. The details of the review are presented in Chapter 3.

One method to mitigate the high levels of visual clutter on the RNAV and RNP procedure depictions was evaluated. This method was to reduce the number of flight paths shown on a single page by means of separating the depicted paths to multiple pages. An experiment was conducted to investigate this method as a potential technique to reduce visual clutter encountered on complex RNAV departure and RNAV (RNP) approach procedures. FAA AeroNav Products and Jeppesen created a set of modified charts that implemented the de-cluttering technique. The details of the design of the experiment are presented in Chapter 4.

The experiment was designed to compare information retrieval performance (in terms of time and accuracy) between current charts and modified (de-cluttered) charts. Pilots were found to answer questions faster using the modified charts than current charts. This effect was found to be statistically significant with a p-value of less than 0.01. In addition, there was not statistically significant difference between modified and current charts. The results of the experiment are described in Chapter 5.

¹ The safety reports from ASRS was obtained as part of a separate task performed to analyze safety reports involving RNAV and RNP procedures for the study and the details for the analysis are presented in Appendix A.

Chapter 2

Background

Instrument procedures are used during three key phases of flight: departure, arrival and approach. In this study, RNAV (RNP) Instrument Approach Procedures (IAPs), RNAV Standard Instrument Departures (SIDs) and Standard Terminal Arrivals (STARs) are examined. Figure 3 illustrates the relationship between the phases of flight and the instrument procedures.

SIDs are designed to provide a transition from the terminal area to the en route area. STARs serve as a parallel to SIDs, allowing aircraft to descend to the terminal area from the en route environment. Typically, IAPs begin where STARs end and guide an aircraft to the runway where a safe landing can be made [FAA-H-8083-15A].

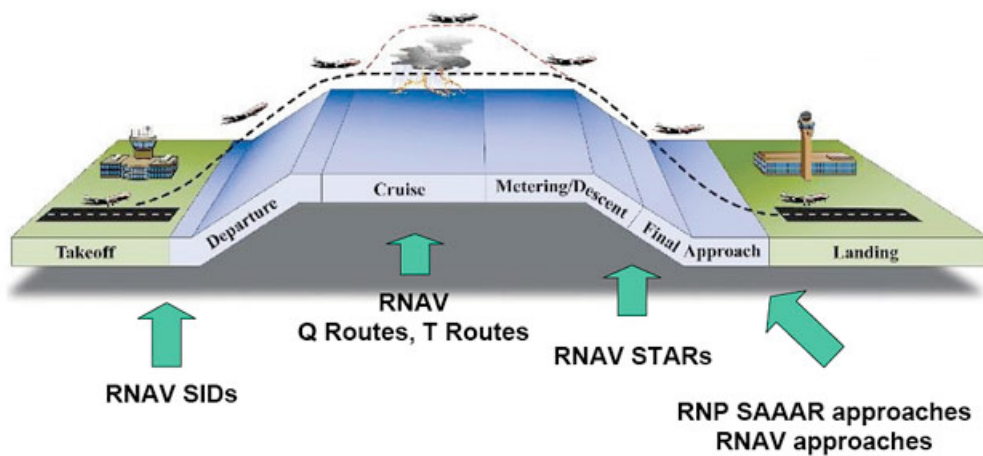

Figure 3. RNAV and RNP procedures availability for each phase of flight [Professional Pilot Magazine, 2010]

This chapter provides an overview of how these instrument procedures are published in chart format. Section 2.1 describes the layout of the different charts for each procedure category. Section 2.2 provides an in depth review of previous studies and evaluations conducted on chart design.

2.1 Current Depiction of Instrument Procedures

Instrument procedure charts are intended to provide the pilot with all information required to fly a given procedure during normal flight operations, as well as during abnormal conditions of flight. For example, the charts can contain information that can be used in the event of lost communications or navigation equipment failure. These charts are published in paper and electronic format.

In the United States, all instrument procedures are designed and implemented by FAA's Flight Technologies and Procedures Division (AFS-400), which is part of the Flight Standard Division's Flight Standard Services group. However, the underlying process in the design of these procedures differs for each type of procedure (i.e., SID, STAR, and IAP). For example, IAPs are developed by the FAA AeroNav Products using the criteria outlined in the Terminal Instrument Procedure (TERP) document [FAA 8260]. In order to design an IAP, FAA AeroNav Products generally gathers information about airspace restrictions and traffic flows at a given location. SIDs and STARS, however, are initially developed by local ATC facility that is most familiar with the traffic flow and airspace restrictions of the area. SIDs and STARS are then reviewed by FAA Aeronav and published.

Currently, there are several chart manufacturers that publish and distribute instrument procedures in both paper and electronic format. The US Government FAA AeroNav Products and Jeppesen Sanderson, Inc manufacture the two most widely used charts in the United States. In the following sections, US Government Charts are referred to as FAA AeroNav charts, while charts manufactured by Jeppesen Sanderson, Inc. are simply referred to as Jeppesen charts. Section 2.1.4 discussed the differences in charts between the two

manufacturers in depth. There are no FAA regulations that define specific requirements for the format of charts.

2.1.1 RNAV (RNP) Approach Charts

The Instrument Approach Procedure (IAP) chart can be divided into six main sections: pilot briefing and procedure notes (1), planview (2), airport diagram (3), profile view (4), landing minimums (5), and margin identification such as procedure ID and Airport name (6) (FAA-H-8083-15A). Figure 4 provides an annotated example RNAV (RNP) approach procedure into the DeKalb-Peachtree (PDK) airport in Atlanta, GA.

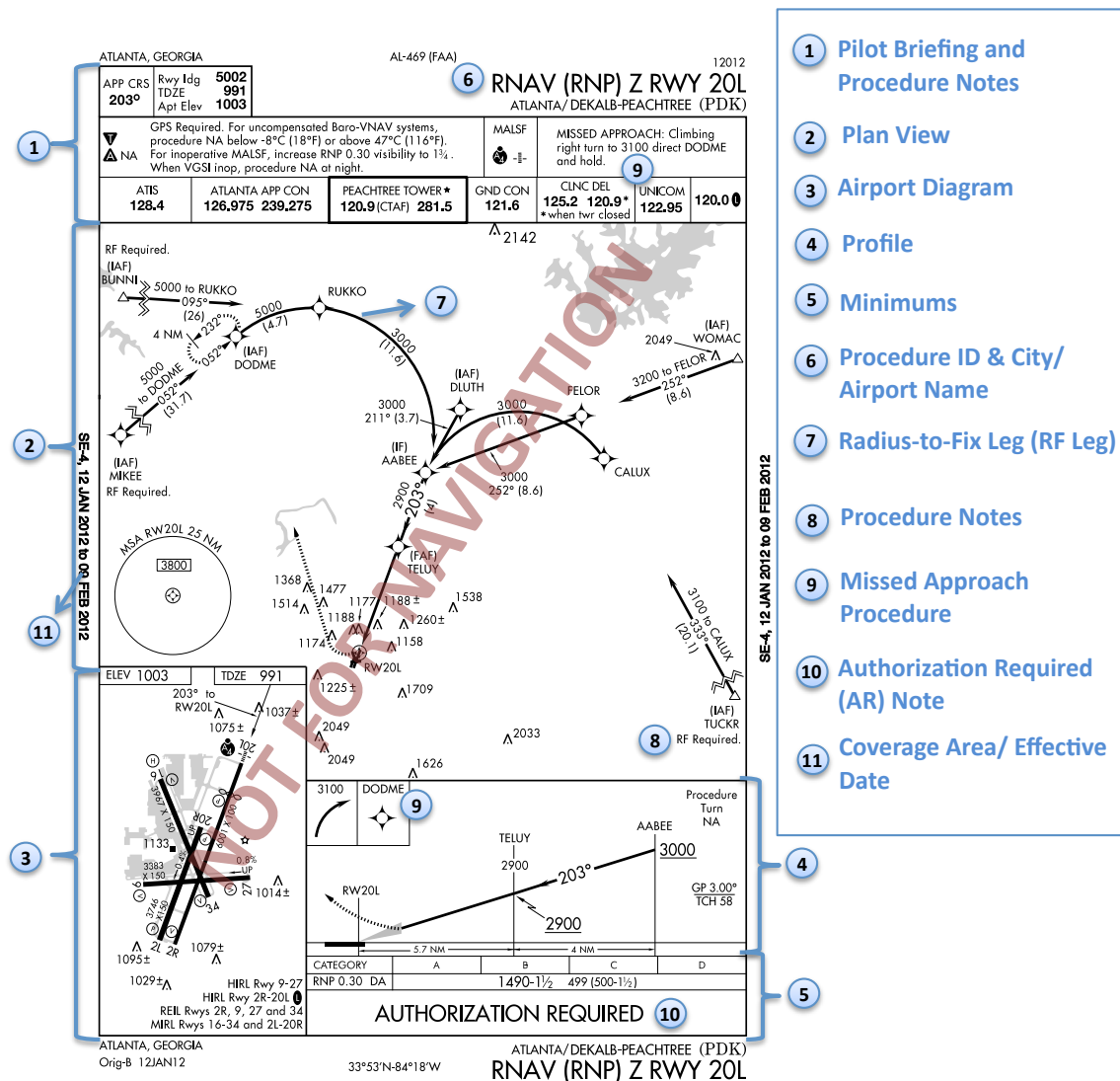

Figure 4. RNAV (RNP) Z RWY 20L, PDK Airport, Atlanta, GA as an example of RNAV (RNP) Approach Procedure

Key elements of a path on the procedure include Initial Approach Fix (IAF), Intermediate Fix (IF), and Final Approach Fix (FAF). These elements combine to create various approach segments, and are typically depicted graphically in the planview and profile view as shown in Figure 5. For each segments, the distance, course, and minimum altitude information is also depicted.

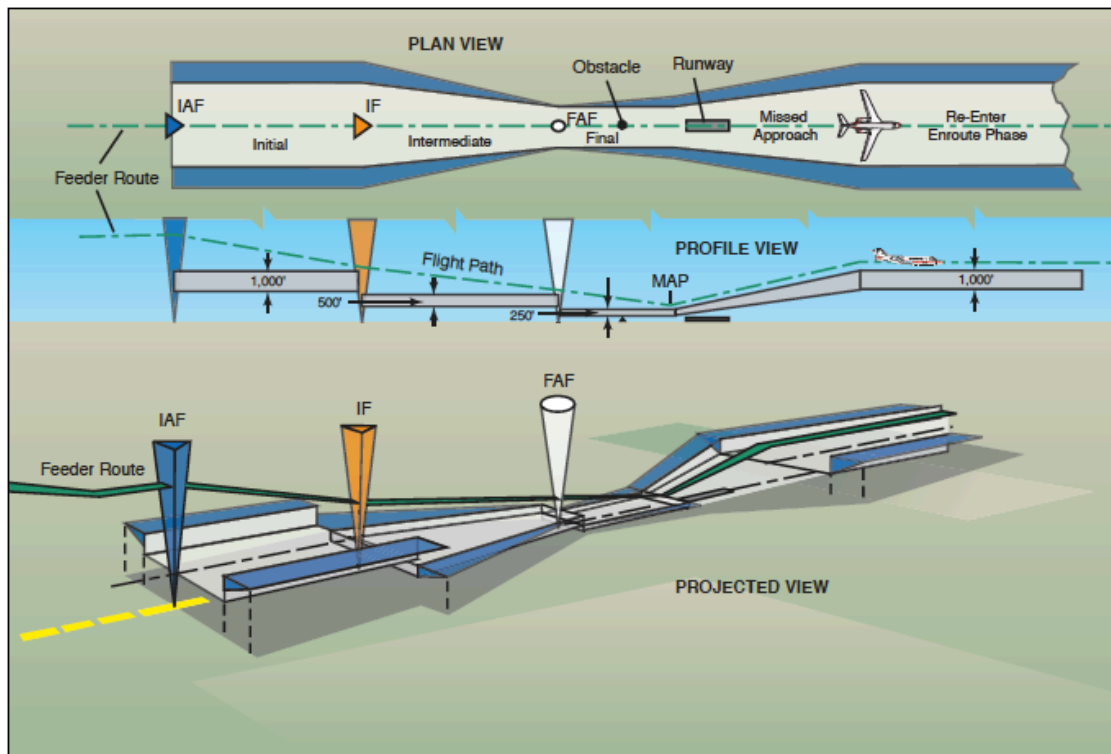

Figure 5. Illustration of the approach segments and transition fixes [FAA-H-9261-1A]

Figure 6 (a) shows an example of conventional approach procedure (ILS or LOC) into Boise Airport. Figure 6 (b) shows an example of RNAV (RNP) AR procedure at Boise Airport. Both example procedures are currently being used at BOI into runway 10R.

The IAF typically represents the beginning of the initial approach segment of the procedure as illustrated in Figure 5. From the example approach procedures depicted in Figure 6, IAF on the ILS procedure is shown by the fix: USTIK, and on RNP procedure is shown by the

fixes: EMETTE, BANGS, UTEGE, EREXE, CANEK, RENOL, CADKI, and PARMO. As seen here, the ILS procedure has one IAF, while the RNAV (RNP) procedure has eight.

The IF represents the completion of the initial approach segment and the commencing of the intermediate approach segment of the procedure. The purpose of the IF is to position the aircraft for a final descent into the airport. As seen from Figure 6, the IF on the ILS procedure is not depicted by a fix. On the RNAV (RNP) procedure, there are five IFs with fixes: EKEME, APISE, JIMMI, ASAYU, and KOLKE.

Finally, the FAF is depicted as a starting point of the final approach segment to the runway. On the ILS procedure, the FAF is where the aircraft's glide slope intercepts the glide path altitude depicted on the chart. FAF is represented by a symbol that looks like a "lightning bolt" and is not commonly depicted by a fix. FAF on the RNAV (RNP) procedure is represented by the fix: ISEBE.

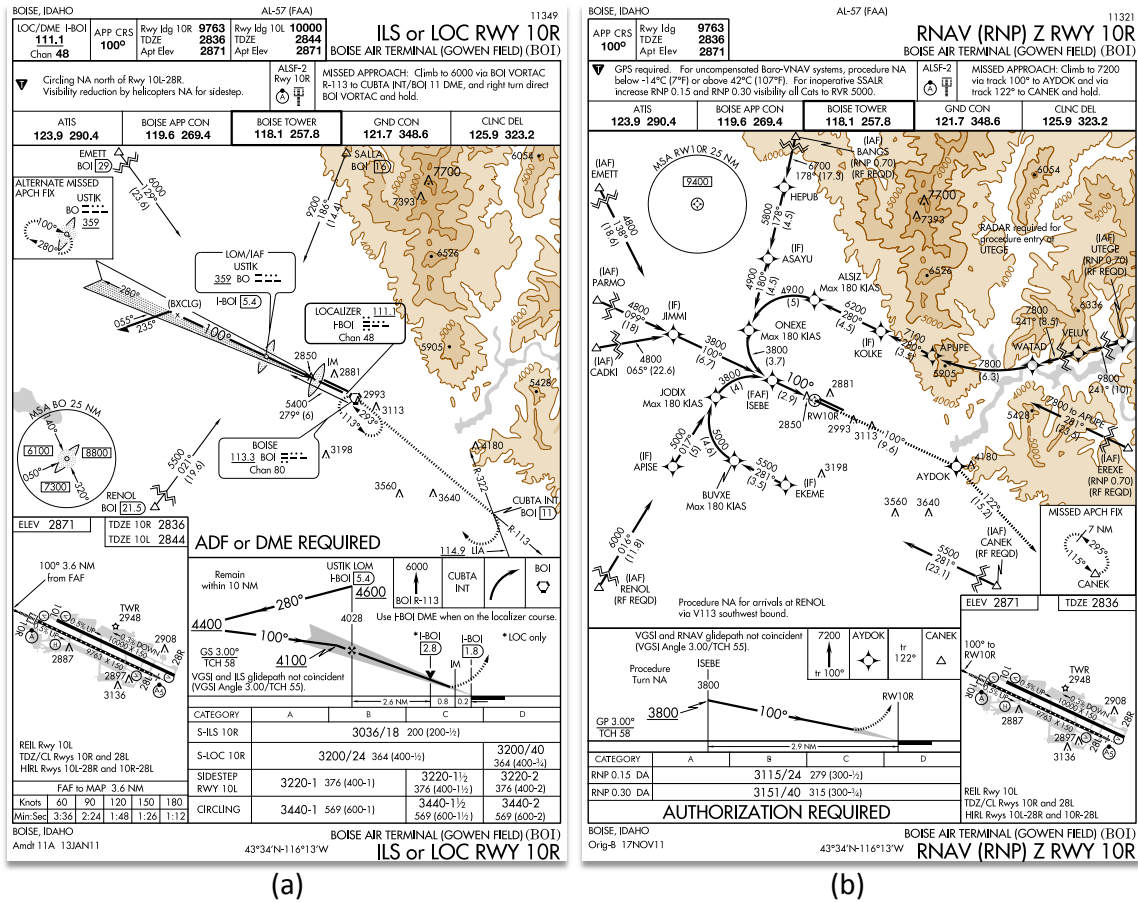

Figure 6. An example of conventional approach procedure (a) and RNP AR approach procedure (b) is shown.

As shown in Figure 6, Boise airport includes high levels of terrain (region depicted in brown). The RNP approach procedure depicted in Figure 6 (b) allows flexibility to navigate terrain by using Radius-to-Fix (RF) legs. RNP procedures are especially beneficial at airports in mountainous terrain as they allow the aircraft to fly curved paths through valleys below the peak altitudes of the surrounding mountains. Conventional procedures such as ILS and VOR/DME rely on ground-based navigation aids and typically restrict the beginning of a descent to 2000 ft above ground level.

One of the major difference between conventional and RNP procedures is that RNP enables more precise path designs with lower minimums compared with conventional procedure. In order to attain this benefit through RNP accuracy and integrity monitoring capability, Radius-to-Fix (RF) legs were developed (# 7 in Figure 4). These RF legs are curved paths

that allow the aircraft to negotiate terrain and airspace while maintaining a shorter and more precise route to the airport via the curved track. The RF capability is required to fly RNAV (RNP) procedure with RF legs as indicated in the notes section of Figure 4 (AC 90-101A).

In addition to the RF capability, the use of '(RNP)' as shown in the procedure title (# 6) and 'Authorization Required' (AR) (# 10)² in Figure 4, alerts crew and ATC that the aircraft must be properly equipped and certified, and the crew must be trained appropriately to fly these procedures (AC 90-101A).

For conventional procedures such as the ILS procedure, one path is typically depicted where the IAF, IF and FAF define the key elements of that path. In addition to these elements, feeder routes are usually depicted to navigate the aircraft from a transition fix in the en route structure to the IAF in the terminal area. As depicted in Figure 6 (a), transition fixes include RENOL, SALLA, and EMETT.

Compared to Figure 6 (a) where only a single approach path is shown, Figure 6 (b), contains multiple IAFs and IFs resulting in multiple paths to be depicted. Here, the IAFs begin in the en route structure to enable the aircraft to take advantage of the RNP capability as far out in the en route area possible. Due to this, all approach procedure segment information (i.e., course, distance, and minimum altitude) is also depicted from the en route structure. The combination of these long multiple paths and the information associated with the paths being depicted on one chart often causes the chart to look more cartographically complex.

In addition, for conventional procedures that typically contain one path, all minimum altitude information related to each approach segment from the IAF or IF is depicted in the profile view (as depicted in Figure 6 (a)). However, in cases where there are multiple paths, the profile view does not show all altitude information for each full path. This is because depicting all paths on one profile view can result in ambiguity for the pilot in determining which path to use. One option is to depict each path on separate profile views however; there is not enough space to show multiple altitude profiles for each of the other paths on one chart. Therefore, new complex RNP procedures received waivers from the FAA such

² "Authorization Required" (AR) was previously referred to as "Special Aircraft Aircrew Authorization Required" (SAAAR). AR is a term used now by both United States and ICAO. Some charts presented in this thesis will have the term SAAAR.

that they only show a limited vertical profile beginning from the Final Approach Fix (FAF) segment that is common to all the trajectories to that runway (FAA TERPS 8260-1). Pilots must refer to the planview for altitude information that is not shown in the limited profile view.

2.1.2 RNAV Standard Instrument Departure (SID) Charts

RNAV Standard Instrument Departure procedures (SIDs) are designed to provide a transition from the terminal area to the appropriate en route structure. Although obstacle protection is considered in the design of all instrument procedures, the primary goal for RNAV SIDs is to reduce the pilot/ATC workload by requiring minimal vectoring and radio communication between the pilot and ATC. SIDs are also beneficial in increasing overall capacity of the NAS by enabling efficient airspace use and effective terminal operations. Similar to RNAV (RNP) IAPs, charts of all RNAV SIDs are publicly available. Pilots are expected to comply with the charted procedure unless ATC has instructed a change in altitude and/or airspeed (FAA-H-8261-1A, Instrument Procedures Handbook).

Figure 7 provides an annotated RNAV SID from the Las Vegas Airport (LAS) in Las Vegas, Nevada. The graphical depiction of the routes includes waypoints, segments, heading and distance information, and altitude and speed constraints and other graphical information pertinent to flying the procedure. The graphical representation of the SID is generally not to scale. RNAV SIDs also contain several notes, which are additional textual information regarding the procedure.

One example of textual notes is the Takeoff Minimums section (# 6 of Figure 7), which describe a minimum climb gradient required to maintain obstacle clearance. According to the FAA Instrument Procedure Handbook, if the aircraft cannot fly the climb gradients specified in the takeoff minimums, the pilots should not accept a clearance to fly that SID (FAA_H_8261-1A). In addition, to avoid obstacles during a departure, the chart may also depict non-standard ceiling and visibility requirements to allow the pilot to “see and avoid” obstacles. For additional obstacle clearance, the Takeoff Obstacle notes (# 11 of Figure 7) are also published. This section typically lists obstacles in the path of each runway departure fix.

The General Notes (# 7 of Figure 7) section typically includes specific equipment and aircraft and avionics performance requirements to fly the RNAV SID. In addition, the

General Notes section may include operational information for non-RNAV equipment (e.g., DME (Distance Measuring Equipment), VOR (VHF Omnidirectional Radio)), and its required performance. The Route Description notes (# 10 of Figure 7) include a textual description of the graphically depicted procedure routes. In some cases, this section may only include the initial departure description until the first transition fix.

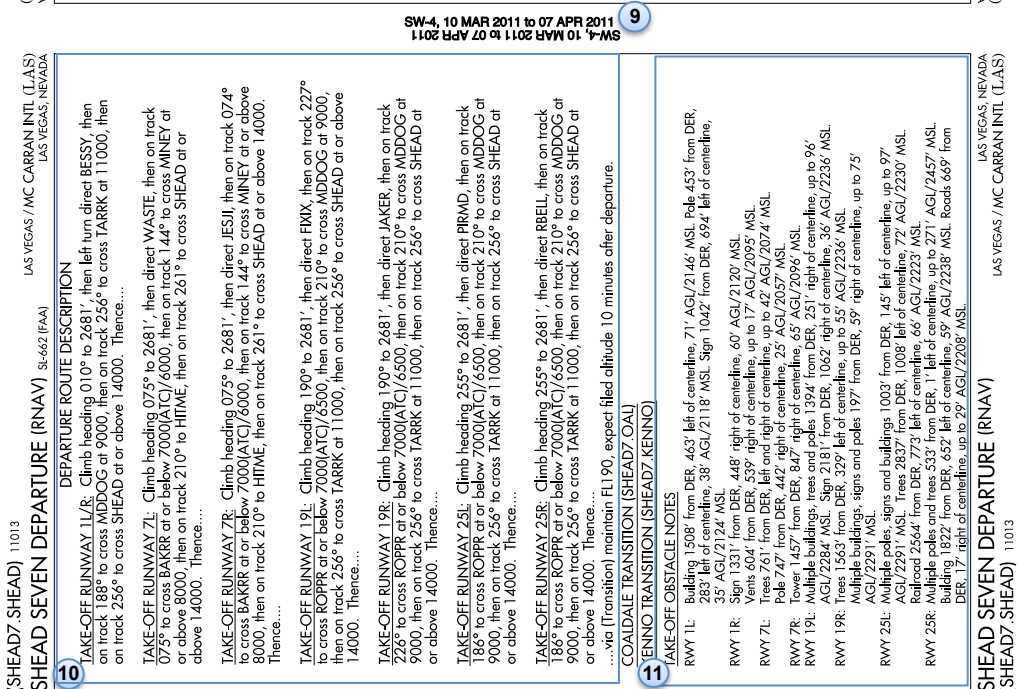
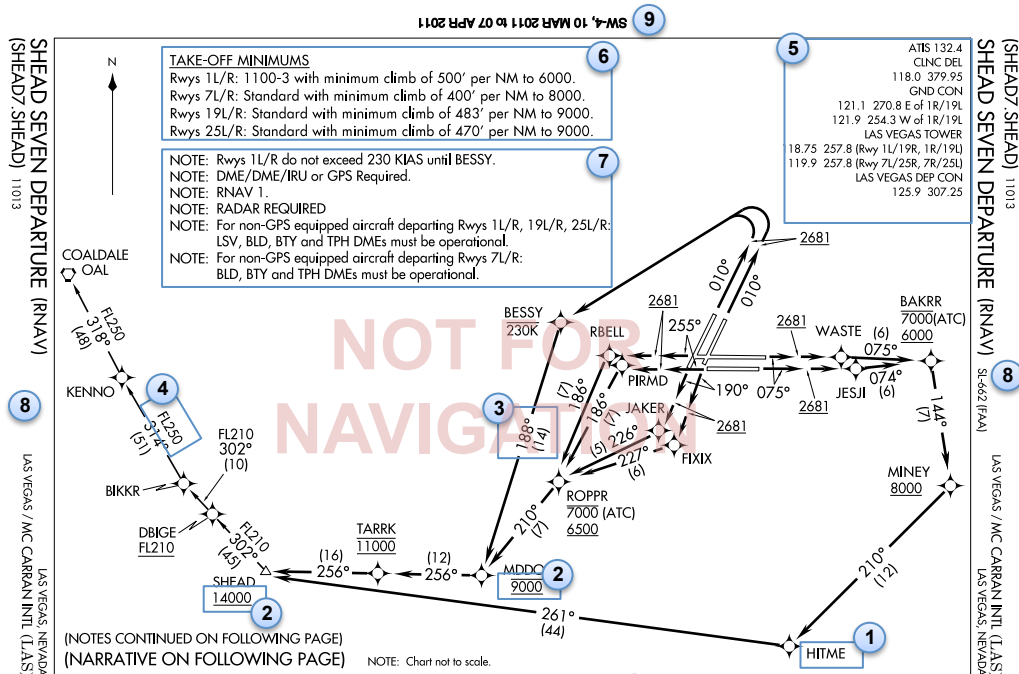

- 1 Waypoint name
- 2 Altitude constraint
- 3 Heading and distance between waypoints
- 4 Minimum enroute altitude
- 5 Communication frequencies
- 6 Takeoff minimum notes
- 7 General notes
- 8 Procedure title and airport information
- 9 Chart coverage date
- 10 Departure route description
- 11 Takeoff obstacle notes

Figure 7. SHEAD SEVEN departure, Las Vegas, Nevada, shown as an example of an RNAV SID.

Figure 8 shows an example of a conventional departure procedure for comparison. Both conventional SID (Figure 8) and RNAV SID (Figure 7) are from the Las Vegas airport. As seen from the figures, the departure are built around ground-based technology. Due to this, all existing ground-based navigation equipment information such as information relating to all VORs (name of VOR, symbol for type of VOR, frequency, mores code, latitude and longitude, etc.) is depicted on the chart.

RNAV SIDs are designed to provide routing from the terminal area to the enroute structure to reduce ATC vectoring and the number of radio transmissions. Comparing Figure 7 to Figure 8, there are fewer waypoints, and paths designed for the conventional LAS VEGAS THREE departure, potentially increasing ATC vectoring. Also, the procedure route description states that “radar vector to transition or assigned route” is to be expected by the pilot. On the other hand, RNAV SIDs have more paths and waypoints, increasing flexibility for an aircraft to depart quickly, using shorter paths and limiting ATC transmissions. However, depicting all information related the paths are necessary to attain this benefit, resulting in an increase in the information density on that chart.

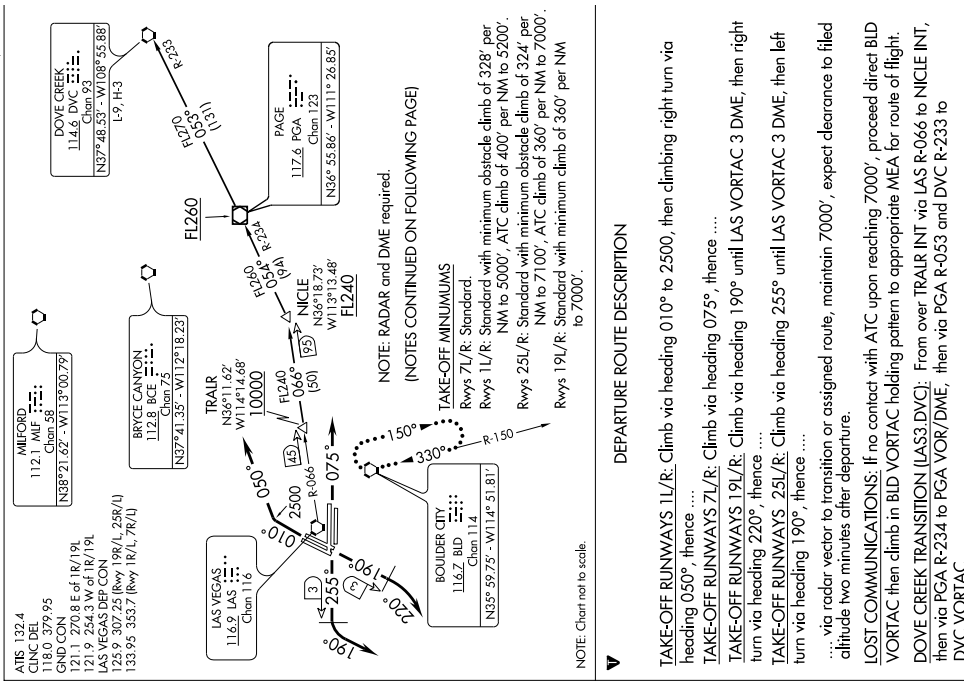
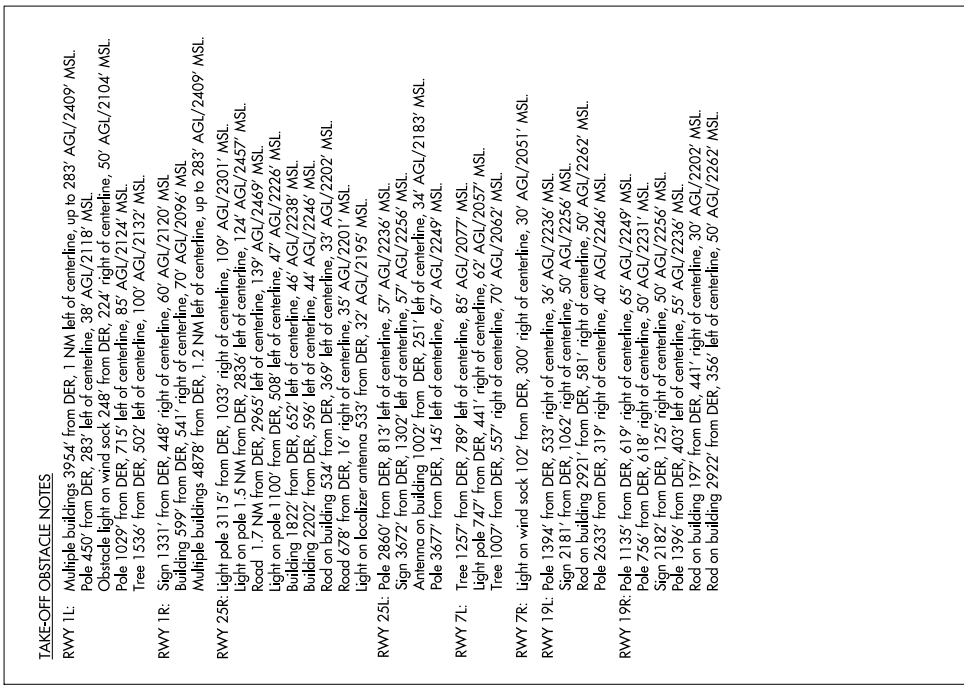

SW-4, 08 MAR 2012 to 05 APR 2012

SW-4, 08 MAR 2012 to 05 APR 2012

SW-4, 08 MAR 2012 to 05 APR 2012

Figure 8. An example of a conventional SID from Las Vegas Airport

2.1.3 RNAV Standard Terminal Arrival (STAR) Charts

STARs are designed as a parallel to SIDs in that they provide a transition from en route environment to the airport environment. Though SIDs enable aircraft to fly from the airport environment to the enroute structure, STARs start from the en route structure and end at a navigation aid or a fix designated by ATC (not the airport environment). Typically, an IAP is flown to guide the aircraft to enter the airport environment.

Both STARs and SIDs reduce pilot-controller workload by minimizing required communication between pilot and ATC. Since the RNAV SIDs and STARs are primarily designed by the ATC facility familiar with the area they often look alike and contain similar information.

Figure 9 shows the KRANN ONE arrival into Boston, MA, as an example RNAV STAR. Similar to RNAV SID, RNAV STAR contains a graphical description of the route depicted by waypoints, headings, distances, and altitude and speed constraints. Like SIDs, STARs are not charted to scale. Typically, STARs also depict holding patterns (# 7 of Figure 9). A pilot will enter a holding pattern if s/he reaches a clearance limit before receiving a further clearance from ATC on the procedure. Each holding pattern will typically depict a series of elements required to fly the hold such as hold fix, direction to and from fix, course or radial, route from which the aircraft is expected to hold.

In addition to the graphical description of the route, RNAV STARs also contain various textual notes related to the procedure. The arrival chart contains a Route Description (# 10 of Figure 9), which describes the graphically charted route in textual format. A General Notes section (# 6 of Figure 9) is also included in the description of STARs to describe equipment and avionics requirements for the procedure. Typically, STARs also contains a section on lost communication procedures, which are included when obstacle clearance is needed to descend safely to the final waypoint without communication with ATC.

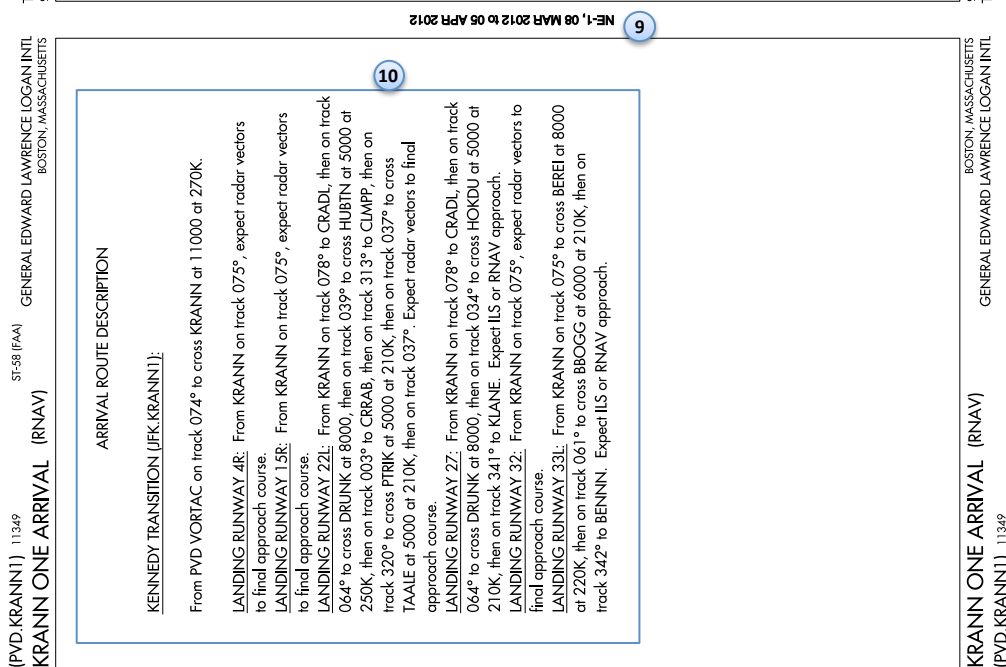
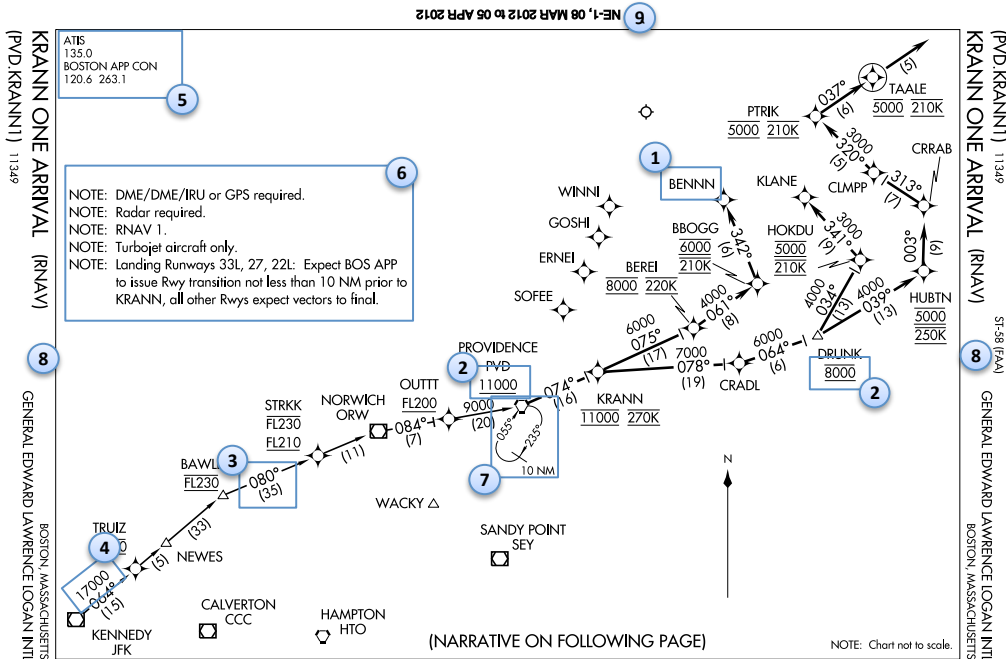

- | | | |
|--|---|------------------------------|
| 1 Waypoint name | 5 Communication frequencies | 9 Chart coverage sate |
| 2 Altitude constraint | 6 General notes | 10 Arrival route description |
| 3 Heading and distance between waypoints | 7 Holding pattern | |
| 4 Minimum enroute altitude | 8 Procedure title and airport information | |

Figure 9. KRANN ONE arrival, Boston, Massachusetts, shown as an example of an RNAV STAR.

Figure 10 shows an example of a conventional arrival procedure to Boston Logan Airport (BOS) for comparison with RNAV STAR described in Figure 9. Both example procedures are currently being used at BOS. As seen from Figure 9, RNAV STARs are more accurately defined compared to conventional STARs using higher number of constraints such as altitude and speed constraints. Similar to conventional SIDS, conventional STARs also depict information regarding the ground based navigation aids.

Similar to RNAV SIDs, RNAV STARs are also designed to reduce ATC vectoring and transmissions by taking advantage of the RNAV capability. Due to this, routes are clearly defined in the published procedure beginning from enroute structure to the airport environment as shown in Figure 9. On the contrary, conventional procedures have much shorter routes and rely heavily on ATC vectoring to descend to the airport environment as indicated in Figure 10.

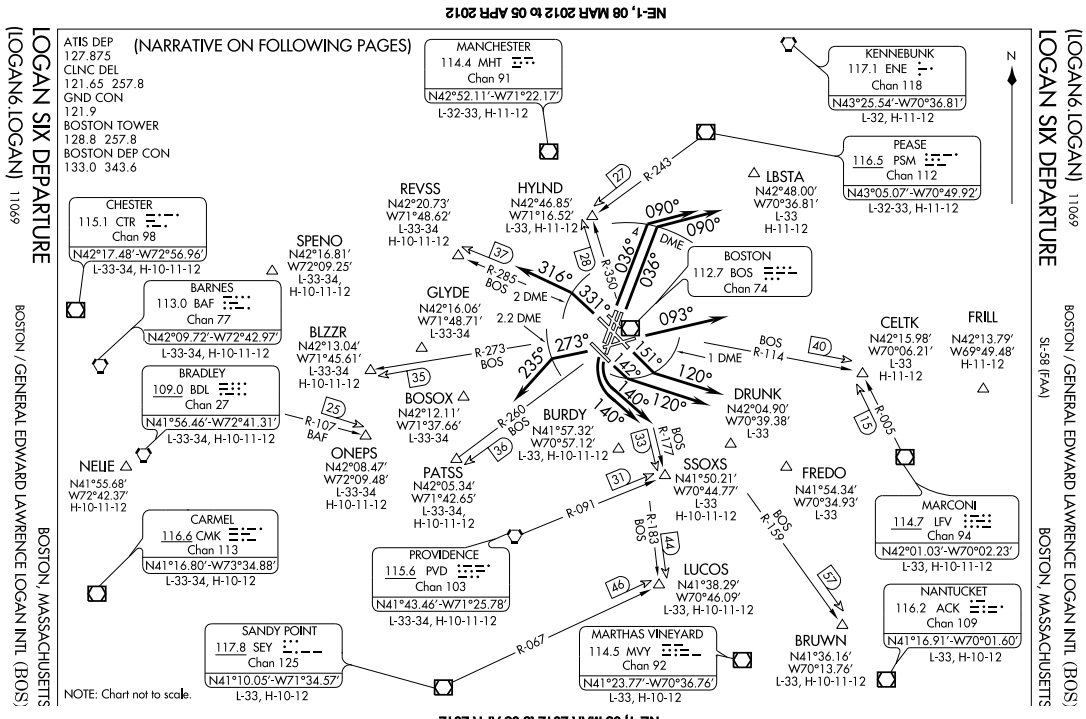

(CONTINUED ON FOLLOWING PAGE)

LOGAN SIX DEPARTURE
 (LOGAN6 LOGAN) 11069
 BOSTON / GENERAL EDWARD LAWRENCE LOGAN INTL (BOS)
 SL-58 (FAA)

DEPARTURE ROUTE DESCRIPTION

JET AIRCRAFT:
 TAKEOFF RWY 4L/R: Climb heading 036° to BOS 4 DME, then turn right heading 090°, thence...
 TAKEOFF RWY 9: Climb heading 093°, thence...
 TAKEOFF RWY 14: Climb heading 142° to BOS 1 DME, then turn left heading 120°, thence...
 TAKEOFF RWY 15R: Climb heading 151° to BOS 1 DME, then turn left heading 120°, thence...
 TAKEOFF RWY 22L/22R: Climbing left turn heading 140°, thence...
 TAKEOFF RWY 27: Climb heading 273° to BOS 2 DME, then left turn heading 235°, thence...
 TAKEOFF RWY 33L: Climb heading 331° to BOS 2 DME, then left turn heading 316°, thence...
NON JET AIRCRAFT: Climb on assigned heading, thence...
 ... Expect radar vectors to assigned route/navaid/fix. Jet aircraft maintain 5000 or lower assigned altitude. Non jet aircraft maintain 3000 or lower assigned altitude. Expect clearance to filed altitude/flight level within ten (10) minutes after departure.

TAKEOFF MINIMUMS:
 Rwy 32, 33R: NA-Environmental.
 Rwy 15L: NA-ATC.
 Rwy 4R: Standard.
 Rwy 4L: 300-1 or standard with minimum climb of 358' per NM to 300.
 Rwy 9: 300-1 1/2 or standard with minimum climb of 257' per NM to 300.
 Rwy 14: 500-3 or standard with minimum climb of 223' per NM to 600, or alternatively, with standard takeoff minimums and a normal 200' per NM climb gradient, takeoff must occur no later than 1900' prior to DER. ATC climb of 500' per NM to 420.
 Rwy 15R: Standard. ATC climb of 431' per NM to 420.
 Rwy 22L: 300-1 or standard if lower reports no tall vessels in the departure area.
 Rwy 22R: 400-2 or standard with minimum climb of 320' per NM to 500.
 Rwy 27: Standard with minimum climb of 474' per NM to 1300.
 Rwy 33L: Standard with minimum climb of 276' per NM to 700. ATC climb of 465' per NM to 400.

Figure 10. An example of conventional STAR at Boston Logan Airport

2.1.4 Chart Manufacturers

Currently, there are two primary chart manufacturers in the United States that publish and distribute instrument procedures in both paper and electronic format. This section will focus on the manufacturers of the two most commonly used charts: FAA AeroNav Products and Jeppesen. The purpose of this section in particular is to describe the various charting techniques implemented by both chart manufacturers to depict complex procedure information.

Figure 11 below illustrate an example of a Jeppesen approach chart into Bozeman Airport. For comparison, Figure 12 shows an example of an approach chart into Bozeman Airport designed by FAA AeroNav. Both charts are reduced to 60% of their original sizes. As seen from the figures, Jeppesen and FAA AeroNav chart manufacturers present the same underlying procedure in the charts. However, the techniques implemented to depict the information on the chart differ.

Both FAA and Jeppesen utilize a standard one-page format that is approximately 5" x 8" to depict approach procedures. The various sections of the chart, such as the briefing strip, plan view, vertical profile (described in detail in Section 2.1.1), are essentially the same for both charts. For departure procedures however, Jeppesen also uses a strip to depict communication frequencies, equipment requirements, airport elevation and transition altitude, while FAA AeroNav does not (Figure 7). Other differences include usage of various chart sizes and number of pages.

The size for both FAA and Jeppesen instrument procedure charts are approximately 5" x 8". However, Jeppesen typically uses "fold-out" charts that are twice the size of a standard chart, roughly 8 ½" x 11" for charts that are highly complex. The larger chart size can be beneficial at airports where high levels of terrain or additional procedural information needs to be depicted such as the approach chart used at Bozeman Airport (Figure 11) or the departure chart used at Las Vegas (Figure 13). Additional space gained in increasing the chart size can enable procedures with high information density to be depicted more clearly.

The number of pages is also a factor in the design of the charts. Typically FAA charts depict arrival and departure procedures in two pages. One page contains the graphical description of the route, while the second page contains textual information that did not fit on the first page around the graphic. Jeppesen charts, however, depict both graphical and textual

information on one page (while increasing size if necessary). Both FAA and Jeppesen typically depict approach procedures on one page. Approach procedure at Boise was one exception to this norm for Jeppesen charts as the procedure was too complex to depict on only one page. Thus, Jeppesen created a second chart with a zoomed in version of the cluttered region to depict the cluttered region more clearly.

FAA chart manufacturing process does not allow for making use of options such as foldouts and increase in chart size. Though techniques including foldouts, increase in chart size and increase in number of pages allow for information to be depicted more clearly by making use of the additional white space gained, they also hold several disadvantages. One disadvantage includes increase in production costs. PARC Charting WG also mentions that these techniques are generally not favored by pilots due to difficulty in managing increased size charts or higher number of pages per chart in the flight deck [PARC, 2009].

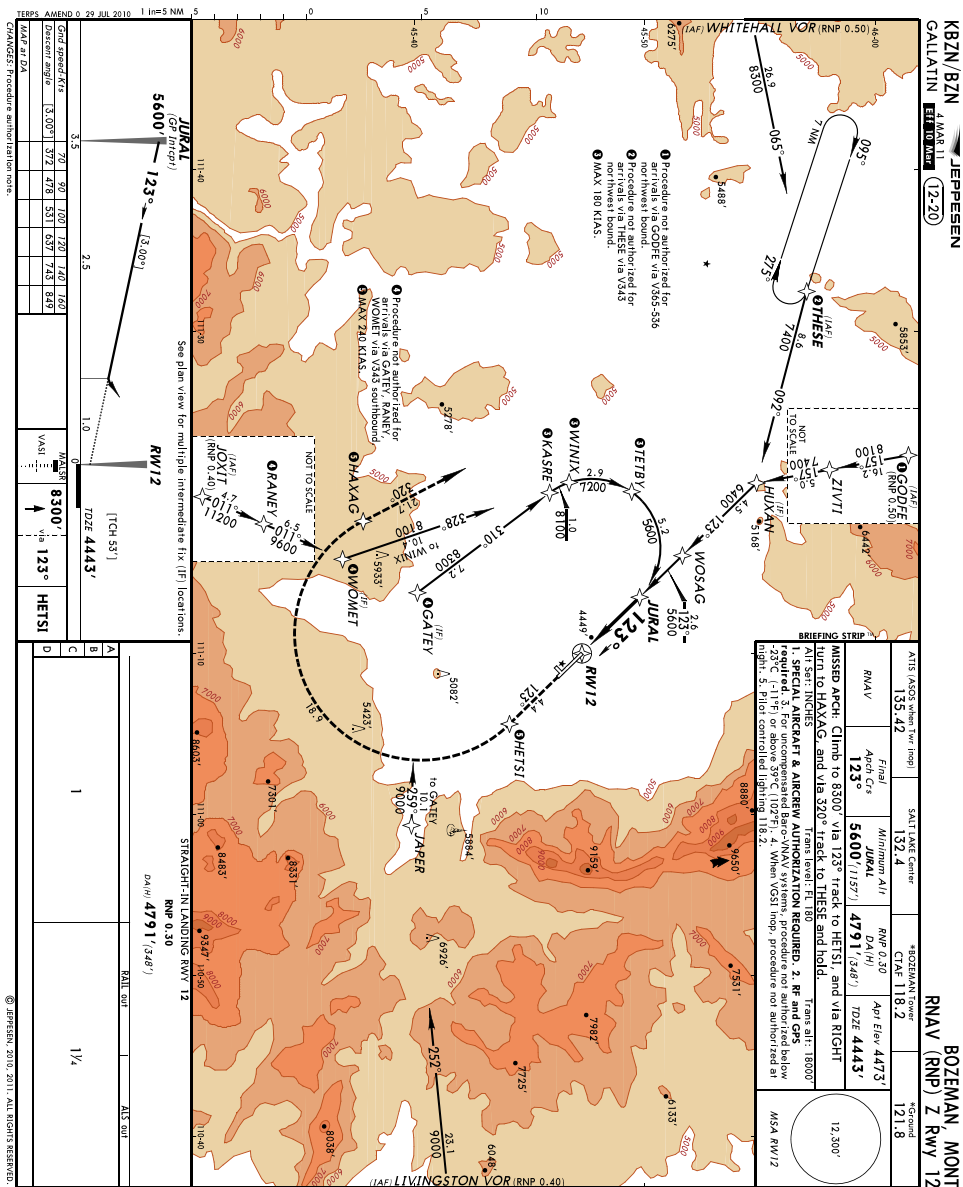

Figure 11. An example of Jeppesen IAP chart into Bozeman Airport

Reproduced with permission of Jeppesen Sanderson, Inc. NOT FOR NAVIGATIONAL USE
 Jeppesen Sanderson, Inc. Copyright © 2011
 Figure reduced to for illustrative purposes only (60 percent of original size)

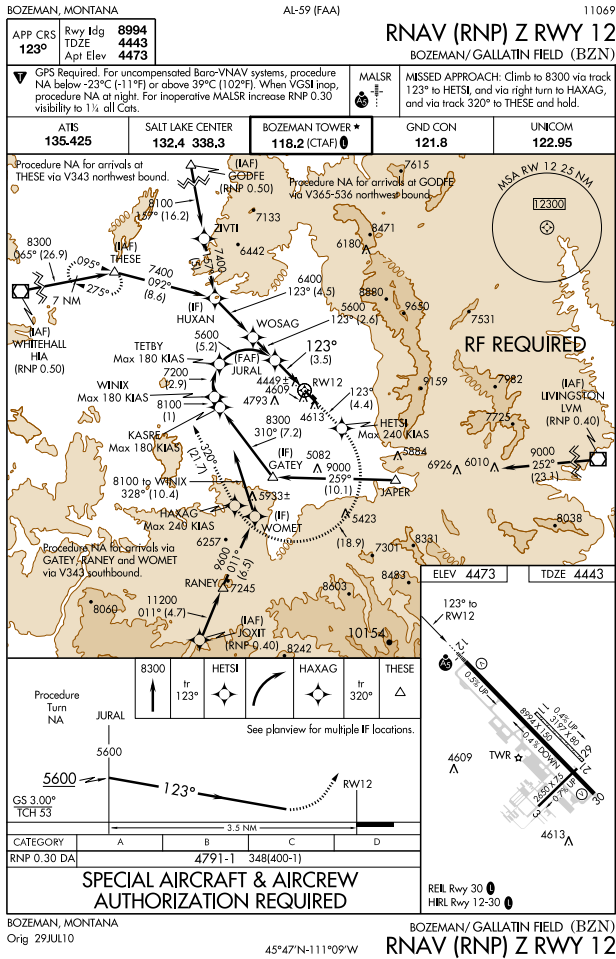

Figure 12. An example of FAA IAP chart into Bozeman Airport.
 Figure reduced for illustrative purposes only (60 percent of original size)

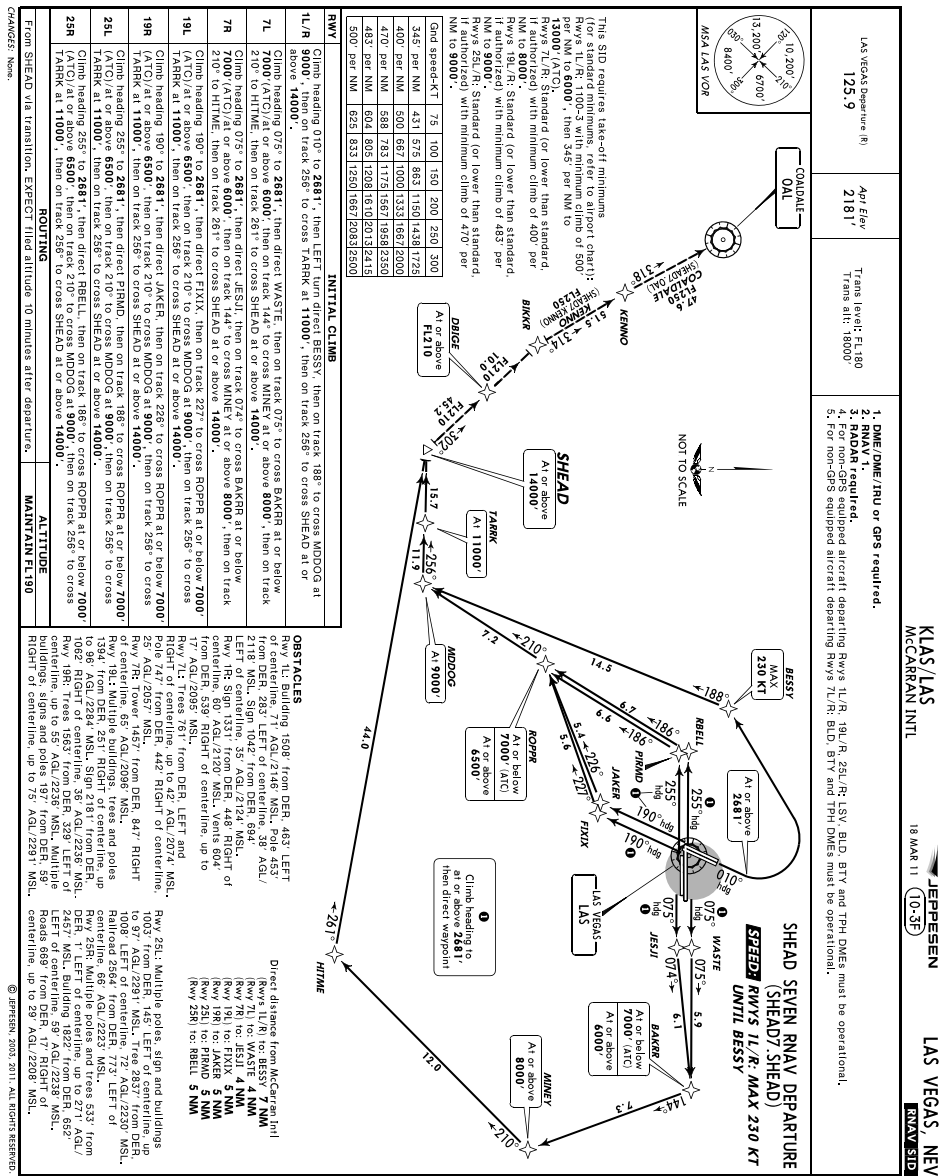

Figure 13. An example of Jeppesen SID chart into Las Vegas Airport

Reproduced with permission of Jeppesen Sanderson, Inc. NOT FOR NAVIGATIONAL USE

Jeppesen Sanderson, Inc. Copyright © 2011

Figure reduced for illustrative purposes only (60 percent of original size)

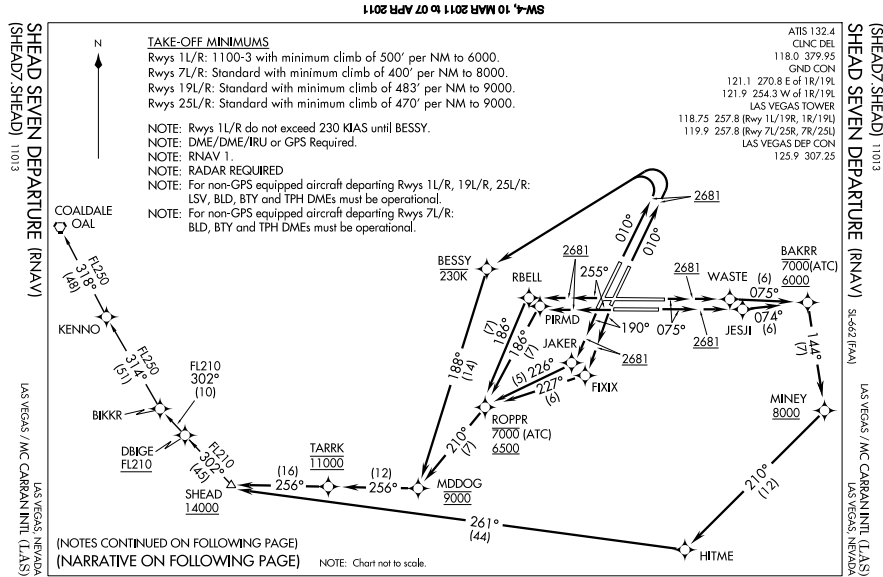

Figure 14. An example of FAA AeroNav Products SID chart into Las Vegas Airport.

Figure reduced for illustrative purposes only (60 percent of original size)

2.2 Previous Studies on Chart Design

The format of instrument procedure charts, particularly IAPs, has evolved through chart manufacturers, human factors studies and organized industry group committees. A number of studies have been conducted by Volpe National Transportation System Center (VNTSC) to evaluate IAP chart design in order to improve the readability of critical procedure navigation and communication information. Multer, Warner, DiSario, and Huntley (1991) examined different methods of presenting the final approach course and communication frequencies. They improved the final approach course by applying graphical techniques such as bolding, boxing [Multer et al, (1991)]

Osborne and Huntley (1992) conducted an experiment to examine the depiction of missed approach procedure information. They varied the amount of information depicted through the use of icons and textual instructions on prototyped charts and compared it against the charts being used in the industry. They used information retrieval performance in terms of speed and accuracy and found that accuracy was worse for instructions with high information content [Osborne et al., (1992)]

Mangold, Eldredge, and Lauber (1992) also reviewed human factors, cartography, chart design literature for efficient information depiction and display. The handbook developed by Mangold et al., is viewed as one of the primary sources for cartography information in the development of IAPs (Osbourne, Huntley, Turner and Donovan, 1995). The handbook identifies the issues encountered by pilots while using charts. Such issues include insufficient lighting, vibration, and turbulence. They also identified the criticality of the approach phase of flight, and the importance of obtaining information quickly and accurately in that phase of flight [Mangold et al., (1992)].

Osbourne, Huntley, Turner and Donovan (1995) conducted a study to examine the briefing strip, which is a strip of information that includes missed approach procedure, communication, and navigation equipment (#1 in Figure 4). They created prototyped charts that included the briefing strip and compared the pilot performance with the charts being used in the industry. The pilot performance was measured using the speed and accuracy with which the pilots retrieved information. In addition, surveys were conducted in this study to understand pilot preference between prototyped charts and charts being used in the industry [Osbourne et. al., (1995)].

Based on the studies conducted by Mutler et al. (1991), Osbourne et al. (1992), Mangold et al. (1992), Osbourne et al. (1995), another study by VNTSC was conducted by Blomberg, Bishop, and Hamilton (1995) to examine the pilot performance of a prototyped chart that included all of the chart features studied thus far related to IAPs. Two prototype charts were created which included briefing strip, approach lighting information, missed approach icons, etc. The pilot's opinions regarding the two prototypes and the current Jeppesen chart were recorded and compared. The findings from the study contributed to the inclusion of the briefing strip and missed approach icons on the currently IAP charts [Osbourne et al., (1995)].

Another study was conducted by Mykityshyn and Hansman (1991) to examine electronically based IAPs (EIAP). The study noted that IAP designs were "too cluttered" making information retrieval for pilots difficult and EIAPs would allow the selection of required information and de-clutter information. The authors conducted an experiment where they compared information retrieval performance of licensed pilots between three experimental IAP charts (*Paper, Monochrome* and *Color*) and three EIAP prototyped charts (*Static, Moving maps* and *EFIS Integrated*). Pilots preferred *Color* IAP charts and also preferred the prototyped information selection and de-cluttering capability to the alternatives. However, information retrieval performance observed in the study showed no significance difference between the three IAP charts and the three EIAPs used in the experiment [Mykityshyn et al., (1991)].

Ricks, Jonsson, and Barry (1996) from NASA conducted a study to determine 1) what types of information were acquired during the approach phase of flight, 2) when in the approach was the information acquired and 3) how these information types should be depicted to augment pilot performance. Ricks et al., performed psychometric scaling techniques and a simulation task to examine the link between pilots' cognitive representation of approach information and their use of the depicted information. Primary findings from the study were that pilots appear to mentally organize information depicted on the approach chart into several specific categories. These categories were later utilized to determine the structure of in the instrument approach procedure chart [Ricks et al., (1996)].

Though IAP chart design has been extensively studied, limited documented human factors studies associated with SIDs and STARs are existent. One reason for this is because SIDs and STARs were developed years after the successful implementation of IAPs. The SIDs and

STARs were primarily developed to expedite ATC procedures and facilitated transition between the enroute and terminal area to accommodate the increase in traffic.

Barhydt and Adams (2006a) from NASA Langley discussed the need for development of human factors guidelines for the design of RNAV SIDs and STARs. Barhydt and Adams identified chart clutter resulting from multiple paths as one of the primary concerns in charting of RNAV STARs and SIDs. Barhydt and Adams (2006b) also reviewed Aviation Safety Reporting System (ASRS) database for operational issues related to RNAV arrivals and departures. They reviewed 124 reports filed between 2000 and mid-2005. Primary findings suggested the need for specific design guidelines for both procedure design and charting [Barhydt et. al., (2006a)].

2.3 Analysis of Safety Reports Related to RNAV and RNP Procedures³

Butchibabu, Midkiff, Kendra, Hansman and Chandra in 2010 updated the analysis performed by Barhydt and Adams (2006b) with a higher number of recent ASRS reports, while outlining detailed human factors issues [Butchibabu et al., 2010]. The goal of the analysis was to understand what performance issues were due to procedure design and charting. The details of this analysis are explained in this section.

2.3.1 Method

Safety reports of interest were identified from the public Aviation Safety Reporting System (ASRS) database. The database contains voluntary self-reported descriptions of actual violation or a “near violation” (i.e., a violation that almost occurred) of a requirement (e.g., an altitude clearance, or published heading for a departure or arrival procedure) typically submitted by pilots. These reports in the database can be searched in a flexible, customizable way. There are limitations to the data contained in ASRS reports, which are described online (<http://asrs.arc.nasa.gov/>). Because of the self-reporting nature of ASRS, reports may contain subjective biases.

³ The published report is shown Appendix A.

The following fields were specified in the ASRS database in order to identify relevant reports Date of Incident, Keyword, Event Anomaly, and Flight Phase. The date of incident was specified from 2004 to mid-2009. The following keywords were included in the search query: RNAV, RNP, Chart, Approach, SID, STAR, DP, IAF, FAF. Event anomaly was specified to: Airspace Violation, ATC issues, Conflict (airborne, NMAC), Deviation – Altitude, Deviation – Procedural, Deviation – Speed, Deviation – Track/Heading, and Flight Phase was specified to: Takeoff, Initial climb, Climb, Descent, Initial Approach, Final Approach, Landing.

A total set of 285 relevant ASRS reports was reviewed to identify human factors issues related to RNAV procedures. Out of 285 reports, 202 were related to RNAV SIDs, 69 were related to RNAV STARs, and 14 were related to RNAV (GPS) approach procedures. No RNAV (RNP) approach procedures were found in the database as they were not full implemented when the reports were extracted in 2009.

Two researchers reviewed the subjective narrative section of each ASRS report independently. The reviewers determined whether the flight deviation that occurred was in the Lateral, Vertical, or Speed domain(s). Lateral issues included deviations in track or heading. Vertical issues pertain to altitude deviations. Reviewers could assign more than one domain to a given report if multiple deviations occurred. The reviewers also iteratively created a list of recurring problems that contributed to the event.

2.3.2 Results

Overall results showed that deviations in the lateral channel were common in ASRS reports related to RNAV departures. Approximately 87% of 202 RNAV departures-related reports had deviations in the lateral channel. For RNAV arrivals and RNAV approaches, common deviations were in the vertical channel. Approximately 43% of 69 RNAV arrivals-related reports and 86% of 14 RNAV approach-related reports indicated altitude deviations as shown in Figure 15.

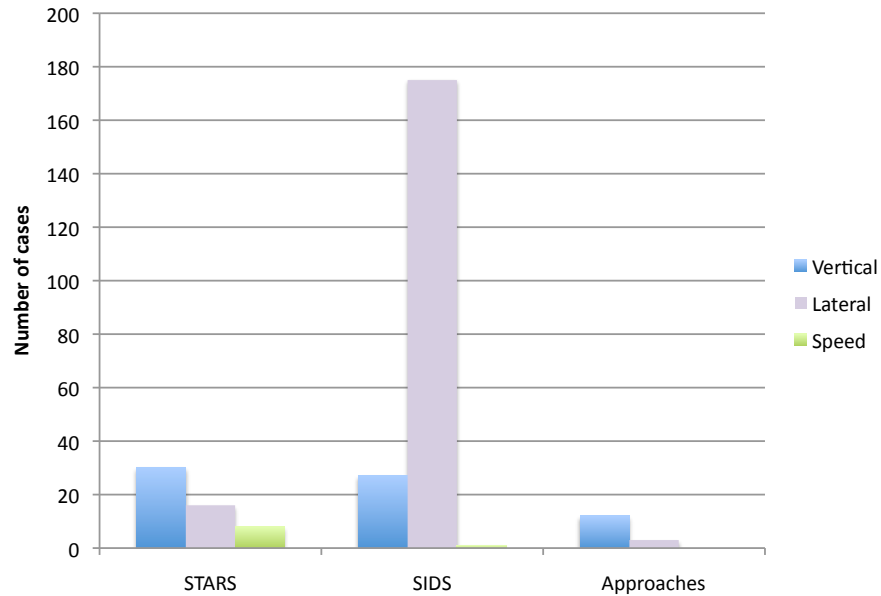

Figure 15. Deviations reported for each procedure type

The list of recurring issues identified for RNAV departures and RNAV arrivals are presented in Figure 16 and Figure 17. Recurring issues related to RNAV approach procedures were not identified due to the low number of procedures that were identified in the database. As mentioned earlier, the most frequent issue with departures was related to flight track/heading, that is, the lateral domain. Figure 16 shows a histogram of departure procedures issues. Four issues were categorized: *ATC Direct To and Resume*, *Climb Direct*, *Dropped Transition Waypoints*, and *Chart & Procedure Design*.

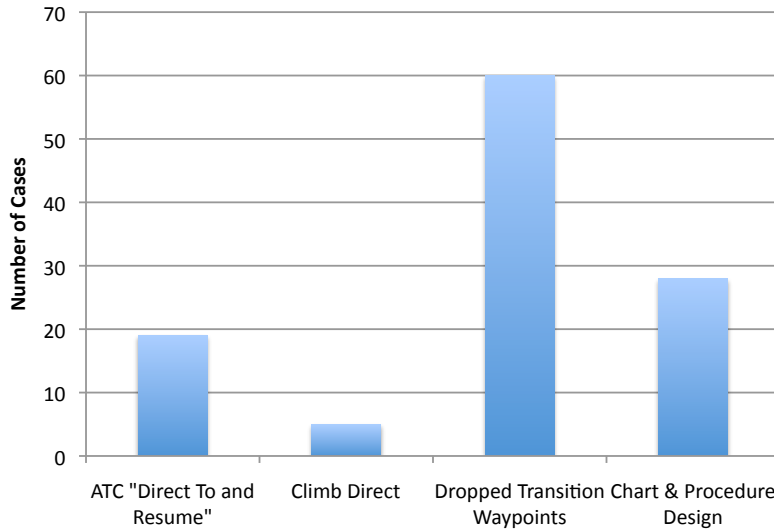

Figure 16. Recurring issues identified for RNAV departure procedures

As seen from Figure 16, approximately 28% of RNAV departure-related reports had issues with chart and procedure design. These issues included pilot deviations related to procedure elements depicted on the chart. Appendix A outlines details related to the other recurring issues encountered in the reports such as *ATC Direct To and Resume*, *Climb Direct* and *Dropped Transition Waypoints*.

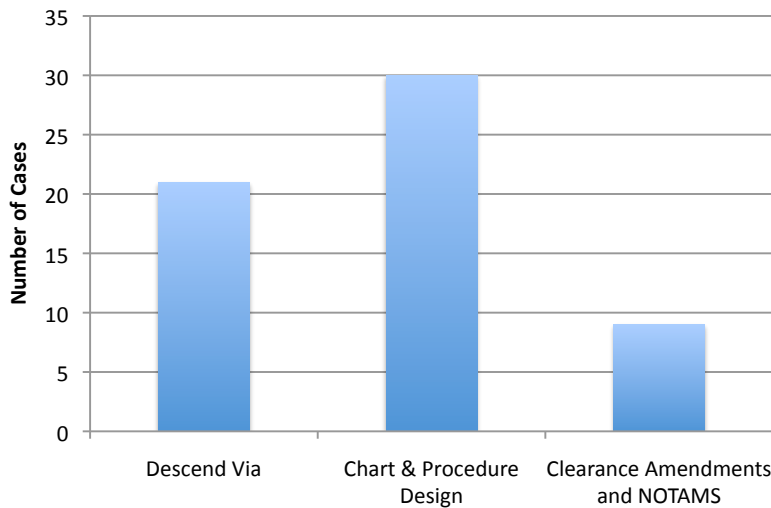

Figure 17. Recurring issues identified for RNAV arrival procedures

The most common issue for arrival procedures –related reports were due to *Chart and Procedure Design*. Approximately 30% of these reports were related to *Chart and Procedure Design* as shown in Figure 17. Other recurring issues encountered include *Descend Via* and *Clearance Amendments and NOTAMS*. These issues are further discussed in the published report shown in Appendix A.

Overall, the ASRS analysis found that 59 out of the 285 ASRS reports were related to *Chart and Procedure Design* issues. However, due to the many limitation associated with the ASRS data discussed above, it was difficult to conclude whether the reports were due to the depiction of the procedure (chart design) or the underlying construction of the procedure (procedure design). Thus, in order to understand charting attributes contributing to operational issues, each chart identified the ASRS may need to be further examined and compared against a pool of charts without operational issues.

2.4 Summary

RNAV SIDs and STARs and RNAV (RNP) IAPs contain more strictly defined paths than conventional procedures. To clearly define these paths, more information such as waypoints, altitude constraints, and headings has to be shown on the chart for each path in the procedure. Several charting techniques have been implemented to depict information more clearly by chart manufacturers as discussed in Section 2.1.4.

In addition, extensive research has been conducted on the depiction of conventional IAPs. However, limited documented research on the depiction of advanced PBN procedures exists. Recent industry committee discussions have raised concerns that there is high information density and clutter on these charts. Research by Barhydt et al. (2006) and Butchibabu et al. (2010) has emphasized the need for evaluating the chart design of these procedures contributing to operational safety issues reported in the ASRS database. Specifically, there is a need to understand what specific procedure elements contribute to the high information density and chart clutter. This is further reviewed in Chapter 3.

Chapter 3

RNAV and RNP Chart Review

In order to objectively identify the procedure variables contributing to operational issues, identified RNAV and RNP procedures that are problematic were reviewed and compared with those that were not problematic. The method used to identify problematic and baseline procedures, and procedure variables used for the comparative analysis are described in Section 3.1 below. Results of the analyses and details about how specific procedures were selected for the review are presented in Sections 3.2, 3.3 and 3.4, which address approach, departure, and arrival procedures respectively. A summary and conclusions of the chart review study are provided in Section 3.5.

3.1 Method

In order to objectively identify the specific procedure variables contributing to operational issues, the following four steps were conducted:

First, for each procedure type (i.e., approaches, departures and arrivals), a group of “Problematic” charts were established for which operational issues were identified. For RNAV departures and arrivals, the charts were identified based on the procedures that were reported in the ASRS reports collected for the analysis described in Section 2.3. However, RNAV (RNP) approach procedures were not fully implemented when the ASRS analysis was conducted in 2009. Thus, the ASRS reports were not used as a source to find Problematic RNAV (RNP) approach procedures. Instead, the Problematic charts identified by industry technical and operational committees were used for approach procedures (Appendix B1 and Appendix B2). Detailed list of airports are described in section 3.2.1, 3.3.1, and 3.4.1 for approach, departure and arrival procedures, respectively.

Second, a group of “baseline” procedures were also identified for each procedure type. The Baseline group was comprised of 35 commercial airports in the United States with

significant activity, called Operational Evolution Partnership (OEP) airports listed in the 2010 MITRE Center for Advanced Aviation Systems Development (CAASD) PBN capability report. If the procedure was already in the Problematic group, it was excluded from the Baseline group.

Third, variables for each procedure type were determined based on an initial inventory of charts. Table 1, Table 4, and Table 7 show the variables reviewed for approach, departure, and arrival procedures, respectively.

Fourth, a comparative analysis was conducted between Problematic and Baseline charts.

United States (US) government charts developed by FAA AeroNav Products were used for this comparative analysis. Although the charts differ between FAA AeroNav and Jeppesen in terms of their graphic design, both chart conventions show the same fundamental procedure design information, and thus, the analysis should be representative of Jeppesen chart versions.

The final set of charts reviewed includes 63 RNAV (RNP) approaches (18 Problematic and 45 Baseline), 52 RNAV departures (37 Problematic and 15 Baseline), and 54 RNAV arrivals (34 Problematic and 20 Baseline). A list of airports from which the charts were extracted are shown in Table 3, Table 6, and Table 9 (for approaches, departures and arrivals, respectively). A complete list of the charts analyzed is provided in Appendix C. All selected procedures were current as of January 12, 2012.

3.2 Approach Procedures

3.2.1 Overview

A total of 13 procedure variables were identified and reviewed for approach procedures. Two variables, number of *paths* and number of *IFs* were reviewed per procedure, while all other variables were recorded per path. Table 2 shows a data sample for an example approach procedure at Boise Airport depicted in Figure 18 for each procedure variable shown in Table 1.

Table 1. List of procedure variables used for approach procedures in the chart review

Approaches (13 Variables)	
Recorded per procedure	Paths IFs
Recorded per path	Waypoints from IAF to MAP RF legs Altitude constraints RF legs for missed approach procedure Waypoints between IF to FAF Distance from IF to FAF Distance between waypoints from IF and FAF Waypoints between FAF to runway Distance from FAF to runway Waypoints in the Missed Approach Procedure Type of fix from which vertical profile begins (IAF/IF/FAF)

Table 2. Data sample for an example approach procedure

Airport	BOI (Boise, Idaho)							
Procedure name	RNAV (RNP) Z RWY 28L							
Number of Paths	8							
Number of IFs	5							
Number of segments in the MAP	1							
Number of RF legs in MAP	0							
IAF names	RENOL	PARMO	CADKI	UTEGE	EREXE	CANEK	BANGS	EMETT
Number of waypoints from IAF to Runway	5	6	6	8	8	7	9	9
Number of waypoints between IF to FAF	3	4	4	5	5	5	5	6
Number of RF legs from IAF to Runway	1	2	2	1	0	0	2	3
Distance from IF to FAF	8.5	14.9	14.9	10	10	10	15.6	20.6
Number of waypoints between FAF to runway	0	0	0	0	0	0	0	0
Distance from FAF to runway	3	3	3	3	3	3	3	3
Number of altitude constraints	0	0	0	0	0	0	0	0
Vertical profile starts with	FAF	FAF	FAF	FAF	FAF	FAF	FAF	FAF

BOISE, IDAHO

AL-57 (FAA)

10322

APP CRS	Rwy Idg	9763
280°	TDZE	2858
	Apt Elev	2871

RNAV (RNP) Z RWY 28L
BOISE AIR TERMINAL (GOWEN FIELD) (BOI)

GPS required. For uncompensated Baro-VNAV systems, procedure NA below -14°C (7°F) or above 42°C (107°F). For inoperative MALSRS increase RNP 0.15 and RNP 0.25 visibility to RVR 6000, and RNP 0.30 to 1½. MALSRS MISSED APPROACH: Climb to 6000 via track 280° to JIMMI and hold, continue climb-in-hold to 6000.

ATIS	BOISE APP CON	BOISE TOWER	GND CON	CLNC DEL
123.9 290.4	119.6 269.4	118.1 257.8	121.7 348.6	125.9 323.2

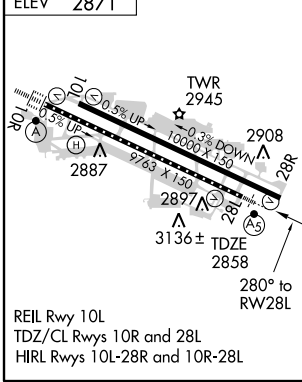
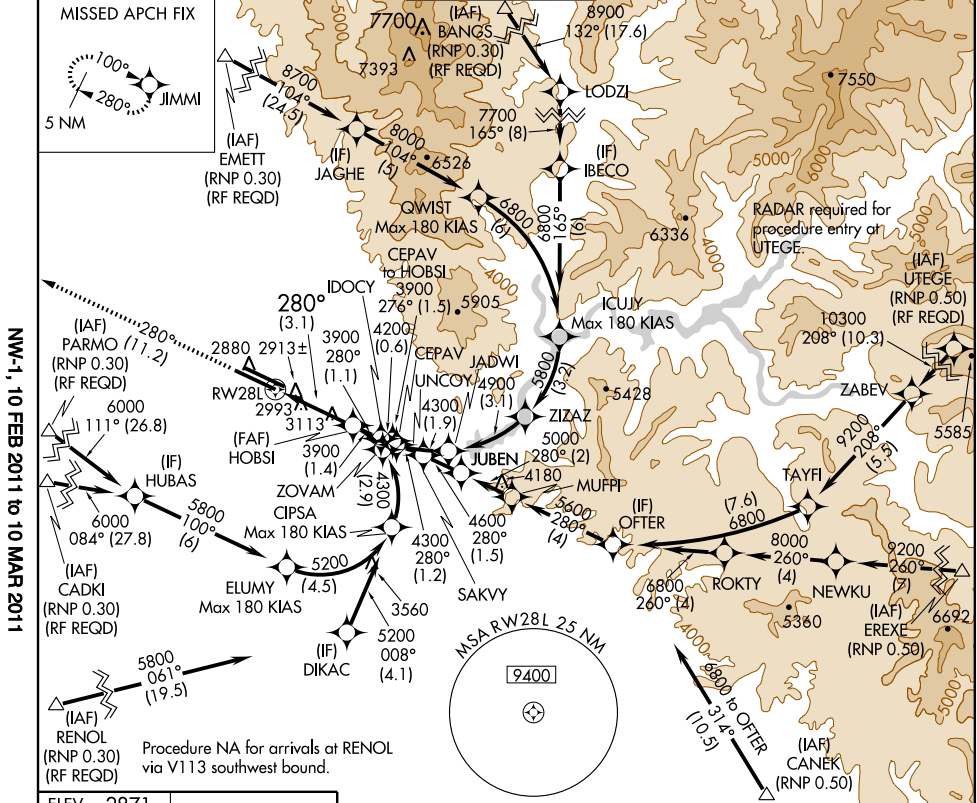

ELEV	2871			
JIMMI	6000			
HOBBSI	3900			
Procedure	Turn NA			
GP	3.00°			
TCH	50			
3.1 NM				
CATEGORY	A	B	C	D
RNP 0.15 DA		3228/40	370 (400-¾)	
RNP 0.25 DA		3250/50	392 (400-1)	
RNP 0.30 DA		3315/60	457 (500-1½)	
SPECIAL AIRCRAFT & AIRCREW AUTHORIZATION REQUIRED				

BOISE, IDAHO
Orig-A 17DEC09

BOISE AIR TERMINAL (GOWEN FIELD) (BOI)
43°34'N-116°13'W
RNAV (RNP) Z RWY 28L

Figure 18. Example RNAV (RNP) Approach Procedure for BOI into Runway 28L

A total of 18 Problematic and 45 Baseline RNAV (RNP) AR approach procedures were analyzed. Airports from which these procedures were studied are shown in Table 3. The individual procedures names analyzed for each airport are shown in Appendix C. As mentioned previously, the Problematic group of approach procedure was identified based on the concerns raised in industry-organized groups such as Aeronautical Charting Forum (ACF) and the PARC RNP Charting Working Group [ACF 09-02-220, 2009]. PARC RNP Charting WG specifically focused on issues with approach procedures at locations such as Boise, Idaho and Raleigh-Durham, North Carolina.⁴

The Baseline group was comprised of all procedure from the top 35 OEP airports. Note that not all OEP airports have published RNP AR approaches, thus there are not 35 airports in the Baseline Airport list. The two groups of procedures analyzed are shown in the Table 3.

Table 3. List of airports analyzed for approach procedures

Problematic (6 airports)	Baseline (12 Airports)
Scottsdale (SDL)	Atlanta (ATL)
Boise (BOI)	Baltimore-Washington (BWI)
Palm Springs (PSP)	Cincinnati-Covington (CVG)
Rifle, Colorado (RIL)	Washington National (DCA)
Bozeman, Montana (BZN)	Dallas-Fort Worth (DFW)
Lewiston, Montana (LWS)	Washington Dulles (IAD)
	Fort Lauderdale (FLL)
	La Guardia (LGA)
	Chicago Midway (MDW)
	Miami (MIA)
	San Francisco (SFO)
	Tampa (TPA)

3.2.2 Results

Figure 19 shows an overview of the analysis between procedures from the Baseline group and the Problematic group. Comparisons between Problematic and Baseline groups were made using independent sample two tailed t-tests with a 95% confidence interval ($\alpha = 0.05$).

⁴ Raleigh-Durham was not included in the Problematic group as it was later simplified as a result of the PARC RNP Working Group recommendations.

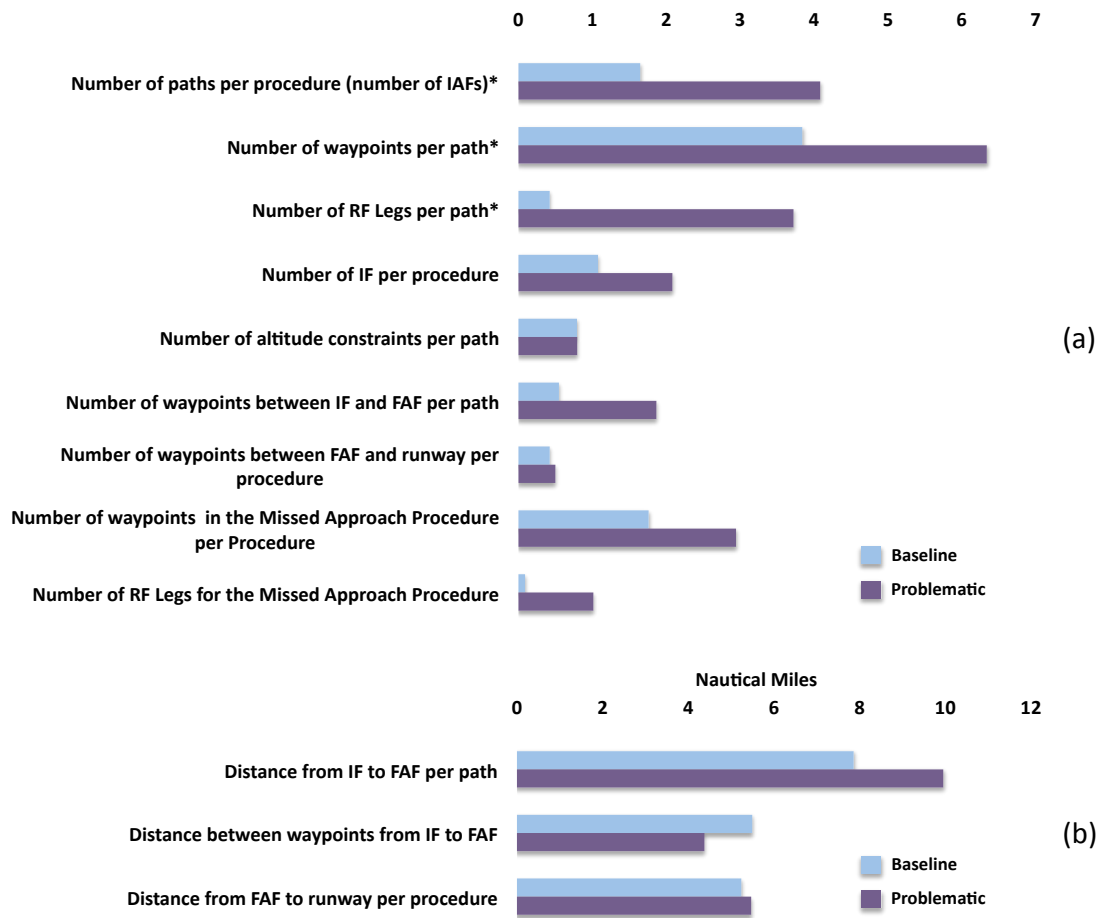

Figure 19. List of procedure elements comparing approaches at Baseline Airports and Problematic Airports A) shows the average number of procedure elements B) shows the procedure elements related to distance

***Statistically significant for 95% confidence ($\alpha = 0.05$)**

According to the analysis, the Problematic group differed from the Baseline group in four primary ways. First, Problematic approaches have a significantly higher number of IAFs, than the Baseline approaches ($t(16) = 3.37, p < 0.05$). For the Problematic group, the mean number of IAFs is 4.1 compared with 1.6 for the Baseline group. Specific averages for each airport are shown in Figure 20. The multiple flight paths may be directly related to the increased information depicted on the chart. This may correlate with the high levels of visual clutter on the planview, because the size of the planview is fixed (unless the physical size of the paper is increased).

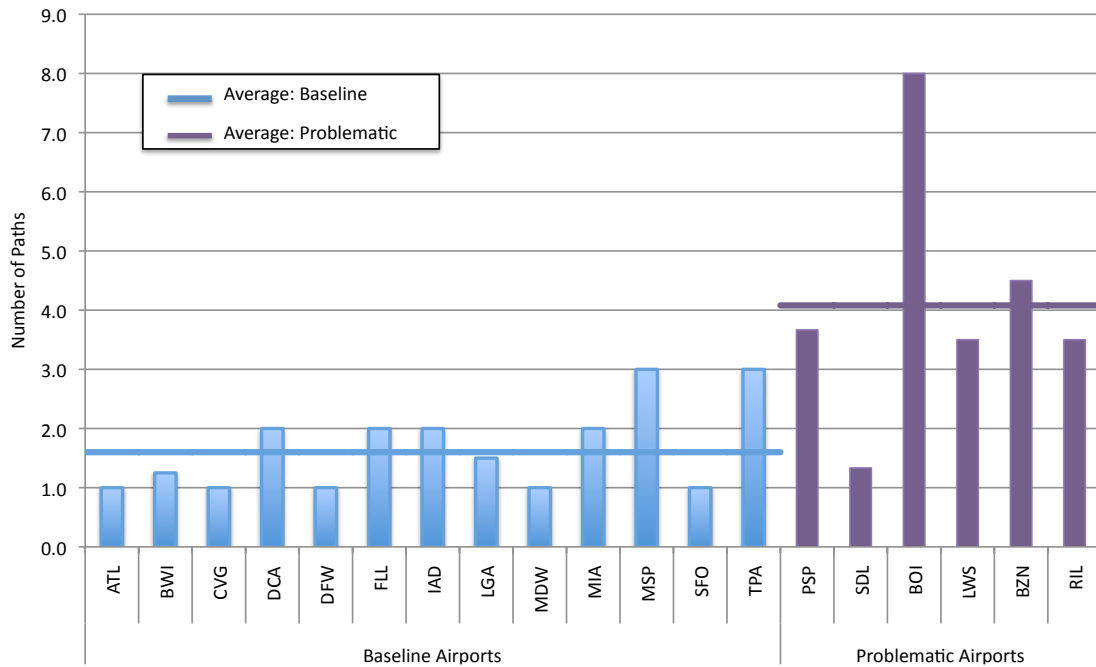

Figure 20. Average number of paths shown for individual airports categorized by Baseline and Problematic.

Second, the analysis showed that when the approach procedure had single path, the profile view information began from the IAF. However, in cases where there were multiple IFs, the procedure showed the altitude profile beginning from the FAF. Figure 21 shows the key procedure fixes (IAF, IF or FAF) from which the vertical profile view begins for each individual airport. The shaded region in the figure indicates that some procedures have profile views starting from either the beginning of the shaded region or the beginning of the boldly colored region. For example, Lewiston airport (LWS) contains some procedures with profile views beginning from IF and some procedures with profile views beginning from FAF. As observed from Figure 21, it is common for RNAV (RNP) procedures to begin from IF, unlike conventional procedures, which typically begins from IAF (described in Chapter 2). However, there are multiple Problematic approach procedures that begin from FAF as these procedures have multiple IFs.

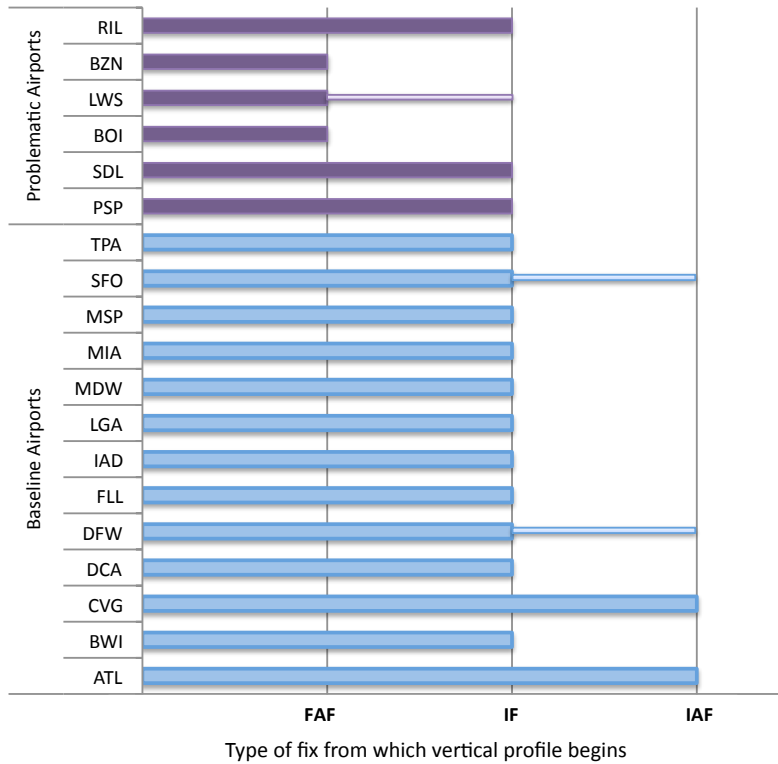

Figure 21. Vertical profile starting fix is shown for individual airport categorized by Problematic Group and Baseline Group. The shaded region shows the range of profile views at the airport

Third, the approaches in the Problematic group has a significantly higher average number of waypoints per path compared to the approaches in the Baseline Group. The Problematic group on average has 6.33 waypoints per path compared to 3.8 waypoints per path for the Baseline group ($t(16) = 6.84, p < 0.01$). The procedures in the Problematic group have a higher number of waypoints compared to any of the procedures in the Baseline group, according to the averages for individual airports shown in Figure 22. An increased number of waypoints could mean a higher number of heading and/or altitude changes resulting in increased information density per path. In addition, pilot workload might be increased because the pilot must monitor all waypoints.

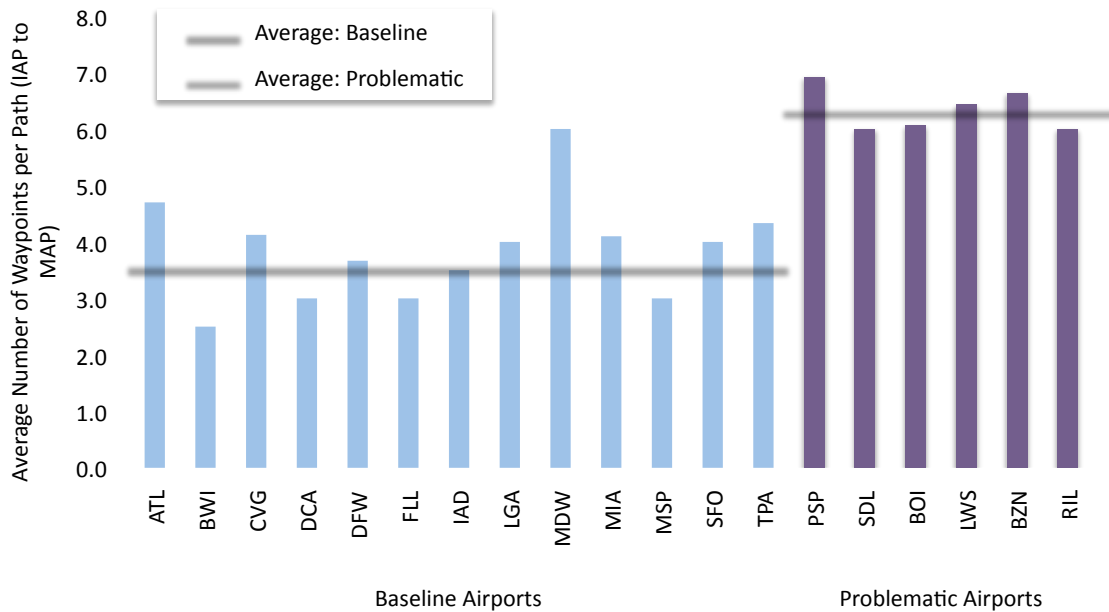

Figure 22. Average number of waypoints per path from IAF to MAP per Airport is shown for Baseline and Problematic Airports.

Finally, the procedures in the Problematic groups have a significantly higher number of RF legs compared to the approach procedures in the Baseline group. On average, the procedures in the Problematic group have 3.7 RF legs per path, while the approaches in the Baseline group have 0.4 RF legs per path ($t(16) = 4.4, p < 0.01$) as shown in Figure 23.

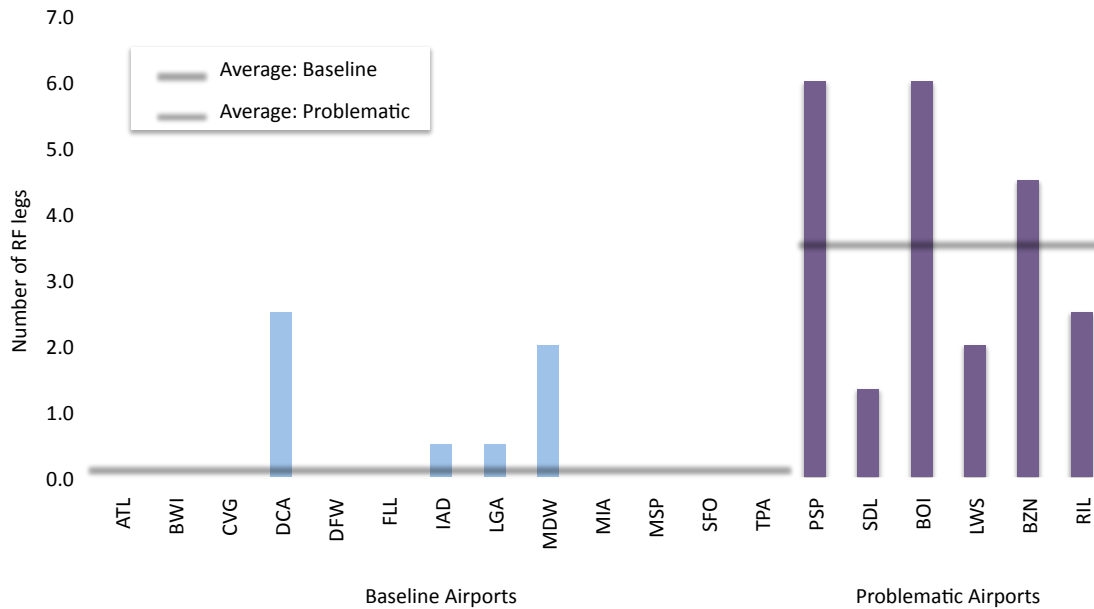

Figure 23. Average number of RF legs per path are shown for individual Baseline and Problematic Airports

In addition to the four primary differences between Problematic group and Baseline group described above, there are other weaker trends that can be observed between the Problematic and Baseline groups of approach procedures. The statistical significance for these variables pass the 90% confidence interval ($\alpha = 0.1$) as opposed to the 95% confidence seen in the four primary trends discussed above. .

First, average number of waypoints for the missed approach procedures per airport is generally higher for the Problematic group compared to the Baseline group as shown in Figure 24. The means are 2.94 segments and 1.8 segments for Problematic group and Baseline group, respectively ($t(16) = 2.35, p < 0.1$). Second, average number of RF legs for the missed approach procedures is 1.0 for Problematic group, which is also higher compared to the 0.1 for Baseline Group ($t(16) = 2.06, p < 0.1$) as shown in Figure 25. Both trends mentioned can contribute to chart clutter and procedure complexity for missed approach procedures.

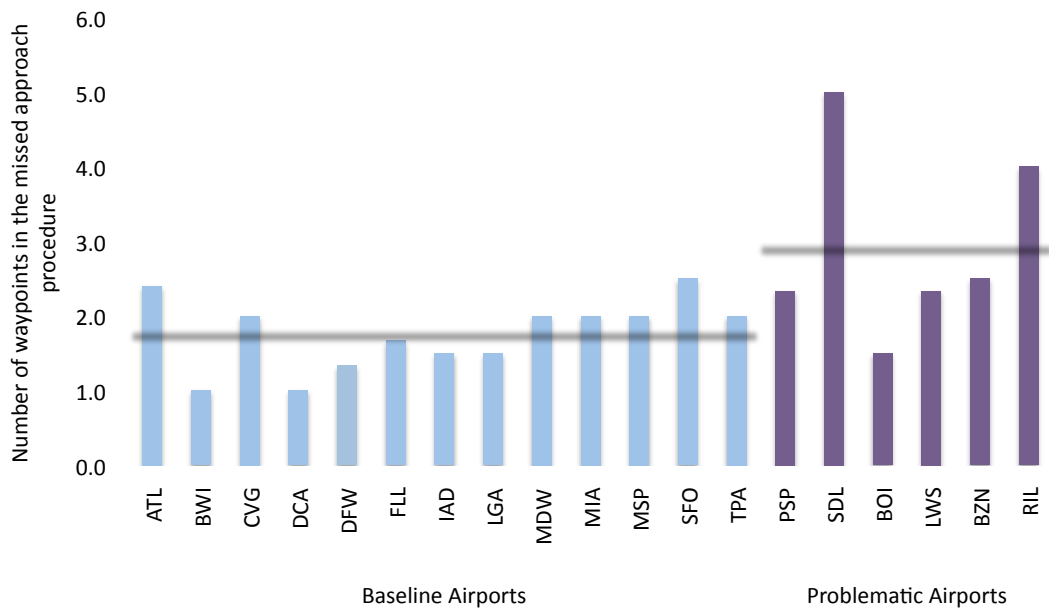

Figure 24. Average number of waypoints in the missed approach procedure is shown for individual airports categorized by Baseline and Problematic

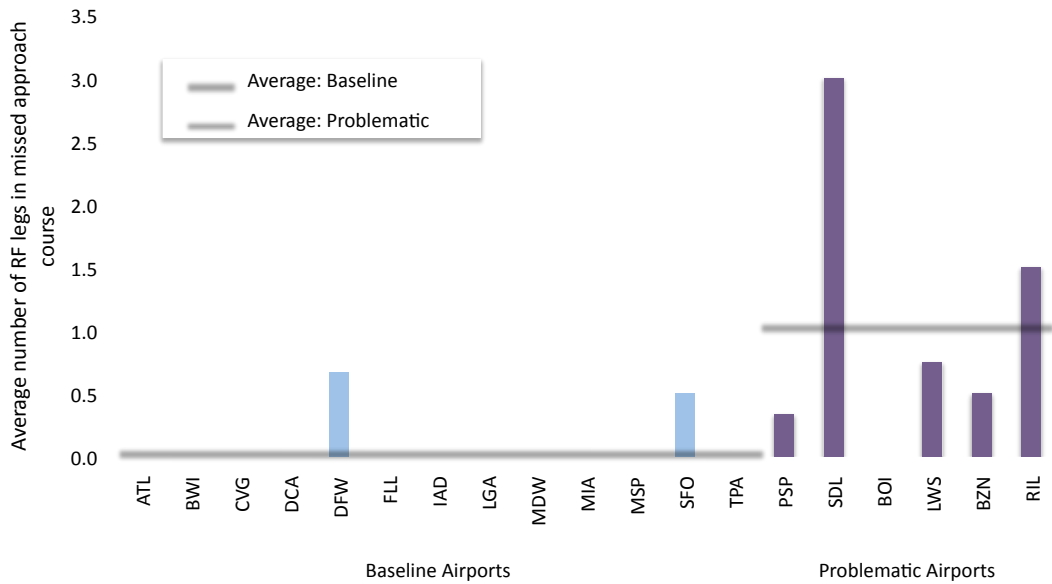

Figure 25. Average number of RF legs in missed approach course is shown for individual airports categorized by Baseline and Problematic

Finally, the average number of waypoints between IF and FAF per path is higher for Problematic group compared to Baseline group, as shown in Figure 26. The mean number of waypoints between IF and FAF are 0.5 and 1.86, for the Baseline group and Problematic group, respectively ($t(16) = 2.55, p < 0.1$). As mentioned, the overall number of waypoints per path is significantly higher for the Problematic approaches compared to Baseline approaches. However, it is important to highlight that this trend exists specifically for waypoints between IF and FAF as there may be increased number of heading and/or altitude changes further into the approach (because waypoints are required at these transition points). This, again, can induce higher pilot workload, as the pilots are required to monitoring these waypoints at more critical phases of the approach procedure.

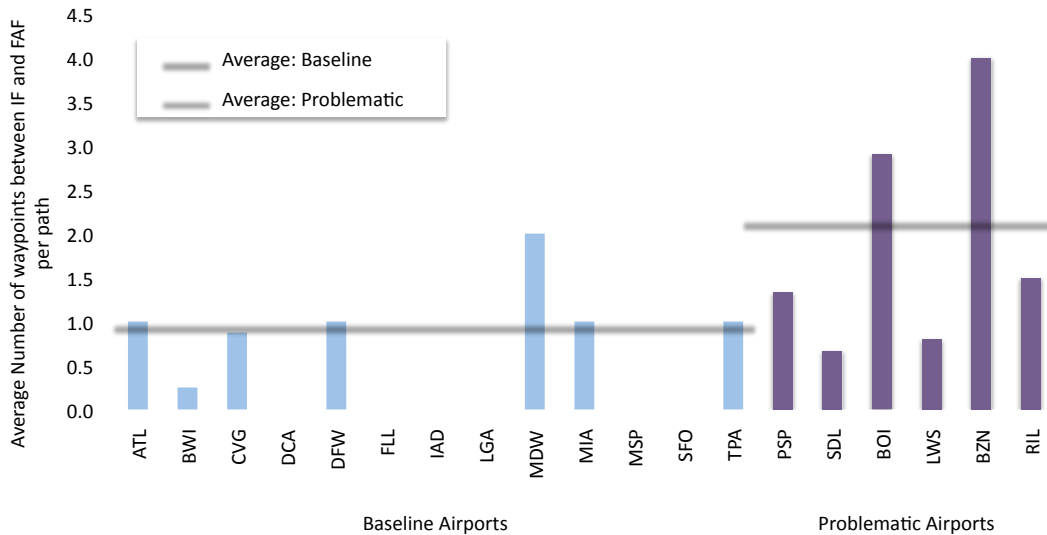

Figure 26. Average number of waypoints between IF and FAF per procedure is shown for individual airports categorized by Baseline and Problematic

3.3 Departure Procedures

3.3.1 Overview

A total of 11 procedure variables were identified and reviewed for departure procedures. Number of *Paths* was analyzed per procedure, while all other variables were analyzed per path. Table 5 shows a data sample for an example departure procedure at Atlanta Airport (Figure 27) for each variable shown in Table 4.

Table 4. List of procedure variables used for departure procedures in the chart review

Departures (11 Variables)	
Recorded per procedure	Paths
Recorded per path	'at or above' altitudes 'at or below' altitudes 'mandatory' altitudes Minimum Enroute Altitudes (MEA) Minimum Obstacle Clearance Altitude (MOCA) 'ATC expect' altitudes Speed restrictions Waypoints Overall distance Distance between waypoints

Table 5. Data sample for an example departure procedure

Airport	ATL (Atlanta)									
Procedure name	BRAVS FIVE									
Number of paths	10									
Flight path names	8L	8R	9L	9R	10	26L	26R	27L	27R	28
At or above altitude	1	1	1	1	1	1	1	1	1	1
Mandatory altitude	0	0	0	0	0	0	0	0	0	0
At or below altitude	0	0	0	0	0	0	0	0	0	0
MEA	1	1	1	1	1	1	1	1	1	0
MOCA	1	1	1	1	1	1	1	1	1	0
'ATC Expect' altitudes	0	0	0	0	0	0	0	0	0	0
Speed restriction	0	0	1	1	1	0	0	1	1	1
Number of heading changes	7	7	5	5	6	7	7	4	4	5
Total flight path length	97	97	74	74	76	105	105	82	82	81
Mean distance overall/waypoint	19	19	25	25	19	21	21	41	41	27

BRAVS SIX DEPARTURE (RNAV)

SL-26 (FAA)

ATLANTA, GEORGIA

ATIS DEP 125.55
 CLNC DEL 118.1
 GND CON
 121.9 381.6 (Rwys 8L-26R, 8R-26L)
 121.75 381.6 (Rwys 9L-27R, 9R-27L)
 121.65 381.6 (Rwy 10-28)
 ATLANTA TOWER
 119.1 381.6 (Rwy 8L-26R)
 125.325 381.6 (Rwy 8R-26L)
 119.3 381.6 (Rwy 9R-27L)
 123.85 381.6 (Rwy 9L-27R)
 119.5 381.6 (Rwy 10-28)
 ATLANTA DEP CON
 125.7 (Rwys 8L-26R, 8R-26L)
 125.65 (Rwys 9L-27R, 9R-27L)
 135.375 (Rwy 10-28)

TAKEOFF MINIMUMS:
 Rwys 8L, 8R, 9L, 9R, 10, 26L, 26R, 28, Standard with minimum climb of 500' per NM to 1527.
 Rwys 27L, 27R, Standard with minimum climb of 500' per NM to 1900.

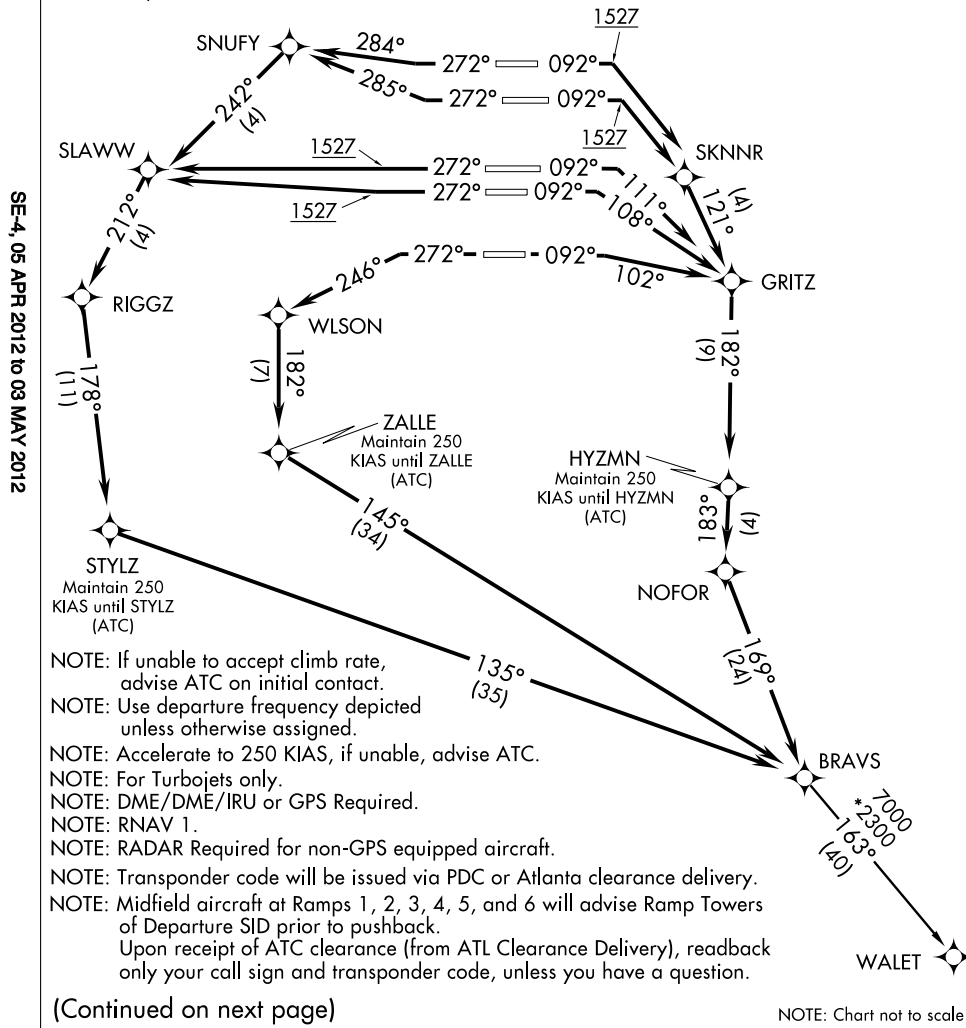

BRAVS SIX DEPARTURE (RNAV)

ATLANTA, GEORGIA

Figure 27. Example RNAV departure procedure at Atlanta Airport

A total of 37 Problematic and 15 Baseline RNAV departure procedures were analyzed. The airports analyzed for this review are shown in Table 6, and the individual procedure names from each airport are show in Appendix C. Problematic group was identified based on results of the ASRS analysis [Butchibabu, et al., (2010)]. For comparison, the Baseline group consisted of two RNAV departures selected at random from each of the top 35 OEP airports. Some airports such as JFK and CLE had only one RNAV departure.

Table 6. List of airports analyzed for departure procedures

Problematic (10 Airports)	Baseline (11 Airports)
Atlanta (ATL)	Cleveland-Hopkins (CLE)
Boston (BOS)	Cincinnati-Covington (CVG)
Baltimore/Washington (BWI)	Newark (EWR)
Dallas-Fort Worth (DFW)	Fort Lauderdale (FLL)
Washington Dulles (IAD)	Dallas-Fort Worth (DFW)
Las Vegas (LAS)	George Bush Intercontinental /Houston (IAD)
Los Angeles (LAX)	John F. Kennedy (JFK)
Miami (MIA)	La Guardia (LGA)
Seattle (SEA)	Phoenix (PHX)
Salt Lake City (SLC)	San Diego (SAN)
	Tampa (TPA)

3.3.2 Results

Figure 28 shows an overview of the comparison between departures from the Baseline group and the Problematic group.

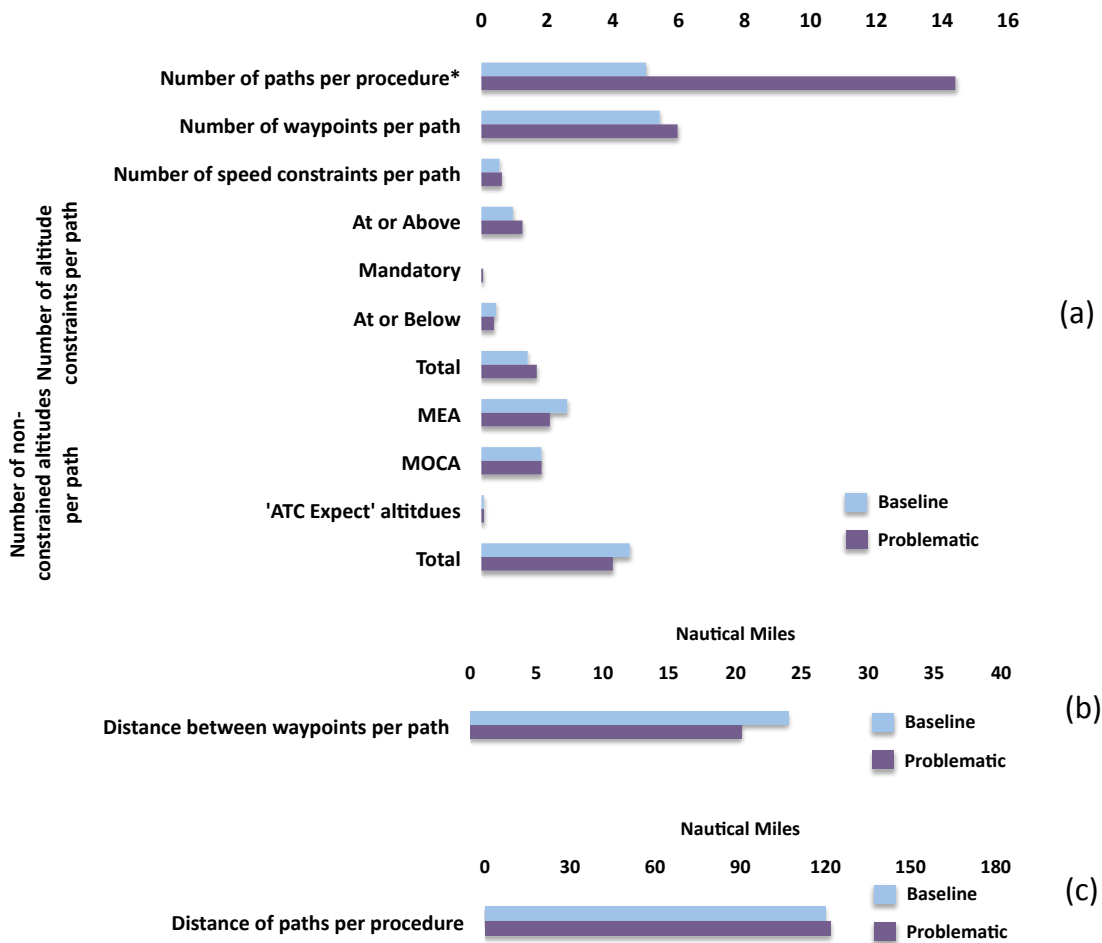

Figure 28. List of procedure elements comparing departures at Baseline Airports and Problematic Airports A) shows the average number of procedure elements B) and C) shows the procedure elements related to distance

*Statistically significant for 95% confidence ($\alpha = 0.05$)

As shown in the Figure 28, one key difference between Problematic group and Baseline group is the average number of paths per procedure compared to Baseline group. Figure 29 shows the individual airport averages for the number of paths shown per procedure. As shown, the average number of paths per procedure is significantly higher for the Problematic group (approximately 14.4) compared to Baseline group (approximately 5.0) ($t(19) = 2.12, P < 0.05$).

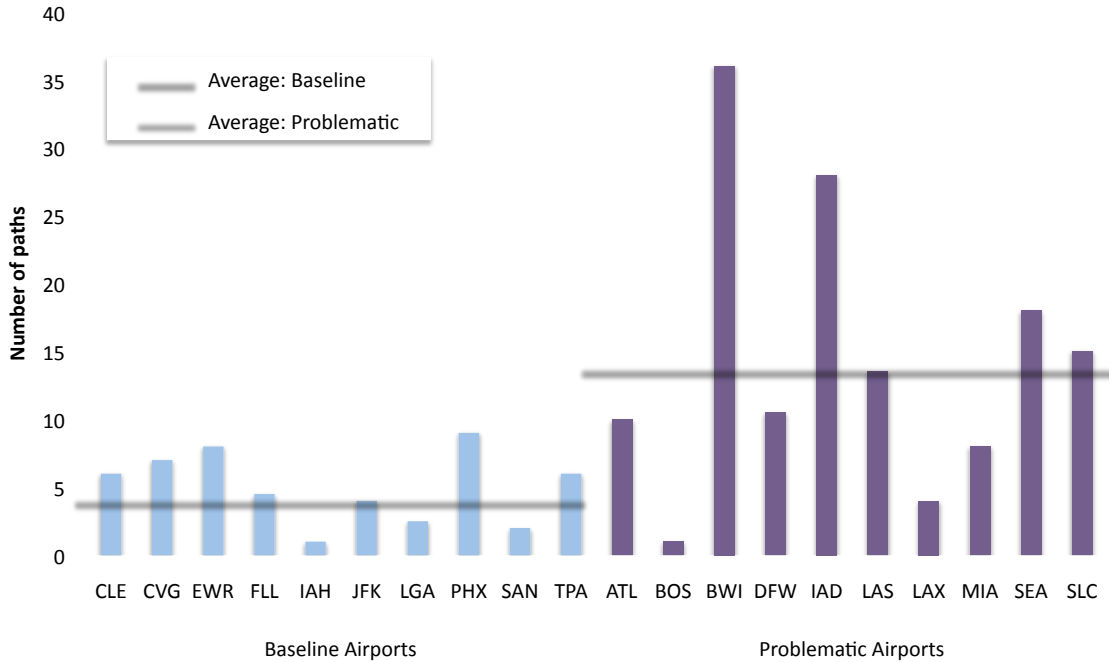

Figure 29. Average number of paths per procedure is shown for each airport categorized by Baseline and Problematic.

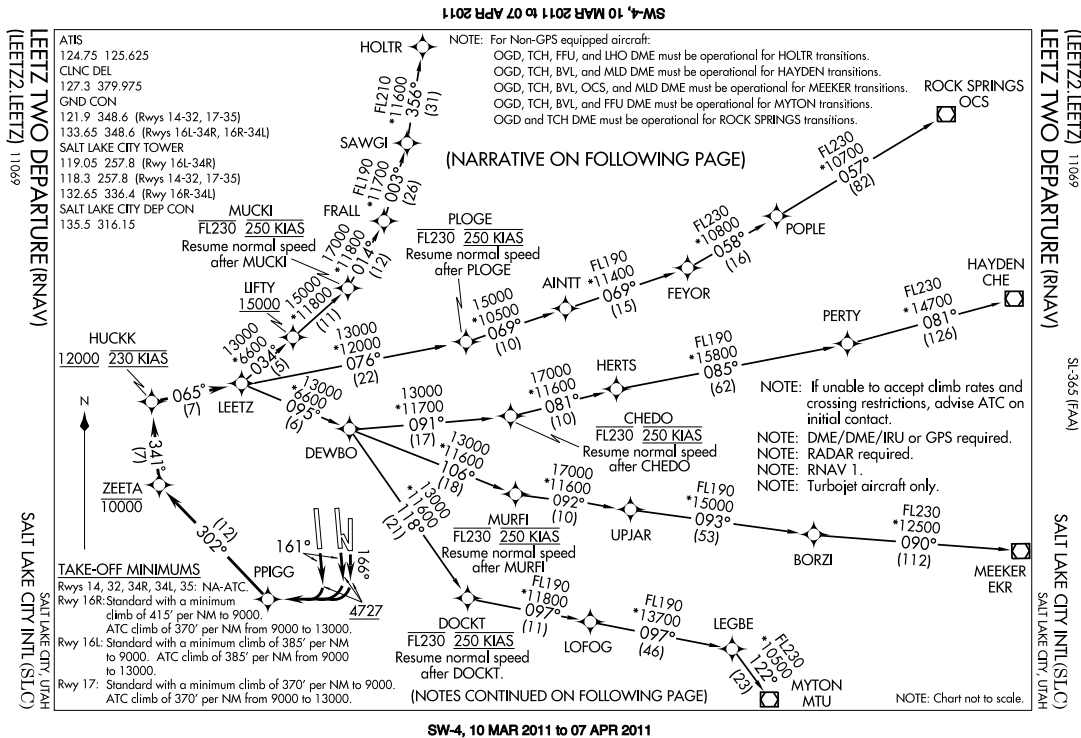

Figure 30. LEETZ TWO RNAV departure at SLC

The number of paths for a departure procedure is recorded as the number of possible combinations an airplane can fly a path which is based on the number of entry and exit points in that procedure. This may not necessarily be the number of paths graphically depicted on the page. For example, the LEETZ TWO departure at SLC, shown in Figure 30, graphically depicts five paths to the final transitions (exit points). However, due to the initial three runway end points (entry points) of the procedure, the total number of paths recorded for the procedure is fifteen. There is more information shown on the charts of procedures with many flight paths than on procedures with few flight paths.

3.4 Arrival Procedures

3.4.1 Overview

A total of 11 procedure variables were identified and reviewed for arrival procedures. Table 8 shows sample data for an example departure procedure at DCA (Figure 31) for each variable shown in Table 7. The average number of *paths* was analyzed per procedure, while all other variables were analyzed per path. As mentioned before, arrival procedures were analyzed similar to the departure procedures. The set of procedure variables for arrival procedures is the same as departure procedure variables with the addition of number of *holding points* per path.

Table 7. List of procedure variables used for arrival procedures in the chart review

Arrivals (12 Variables)	
Recorded per procedure	Paths
Recorded per path	'at or above' altitudes 'at or below' altitudes 'mandatory' altitudes Minimum Enroute Altitudes (MEA) Minimum Obstacle Clearance Altitude (MOCA) 'ATC expect' altitudes Speed restrictions Waypoints Overall distance Distance between waypoints Holding points

Table 8. Data sample for an example departure procedure

Airport	DCA (Washington National)		
Procedure name	ELDEE FIVE		
Total flight paths	3		
Total flight path names	BKW	FIMPA	SHAAR
At or above altitude	1	1	2
Mandatory altitude	4	4	4
At or below altitude	0	0	0
MEA	6	7	6
MOCA	0	0	0
ATC expect altitude	2	2	2
Speed restrictions	0	0	0
Number of heading changes	12	12	9
Number of waypoints	17	17	13
Overall distance per path	244	267	145
Distance between waypoints	14.4	15.7	11.2
Holding points	4	4	3

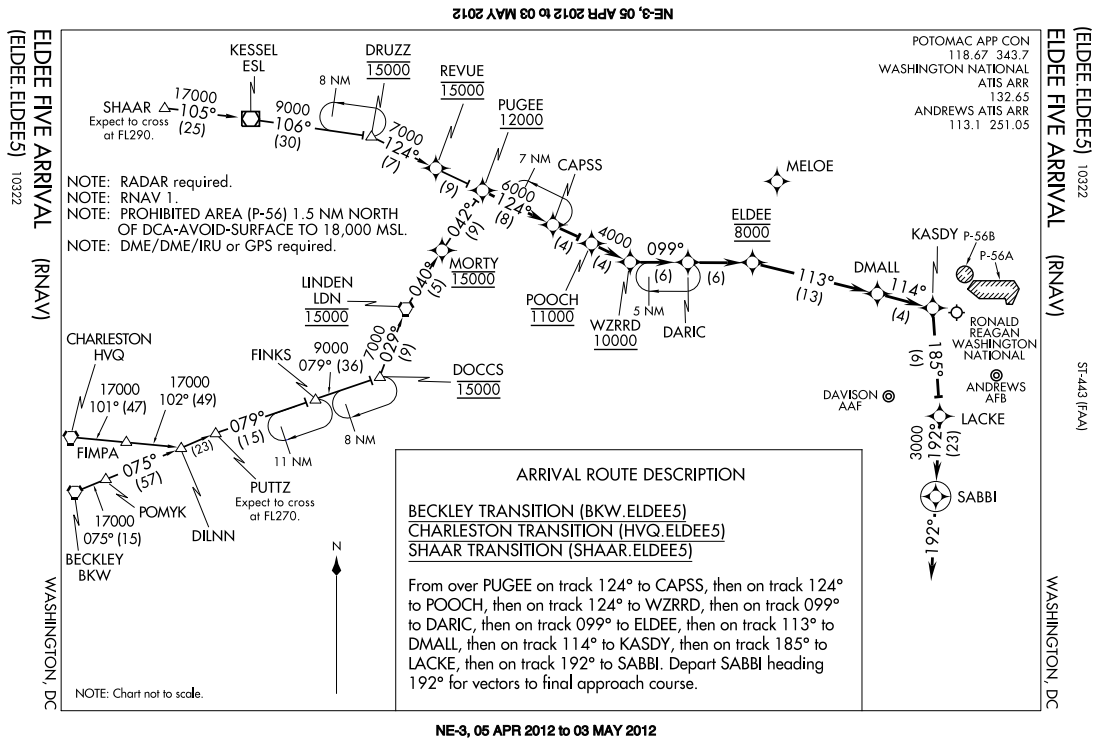

Figure 31. ELDEE FIVE RNAV arrival at DCA

Out of 54 total RNAV arrival procedures analyzed, 34 were identified as Problematic and 20 were identified as Baseline. Airport names from which the procedures were analyzed are shown in Table 9. The process used to select departure procedures was also used to select arrival procedures. The ASRS reports from Butchibabu, et al. (2010) were use to select RNAV arrival procedures for the Problematic group. Two arrivals were selected at random from each of the top 35 OEP airports (MITRE CAASD, 2010) for comparison as the Baseline group. The titles of all procedures for each airport analyzed are shown in Appendix C.

Table 9. List of airports analyzed for arrival procedures

Problematic (13 Airports)	Baseline (11 Airports)
Atlanta (ATL)	Cincinnati-Covington (CVG)
Boston (BOS)	Houston (HOU)
Baltimore/Washington (BWI)	Newark (EWR)
Charlotte (CLT)	John F. Kennedy (JFK)
Washington National (DCA)	Orlando (MCO)
George Bush Intercontinental/Houston (IAH)	Memphis (MEM)
Washington Dulles (IAD)	West Palm Beach (PBI)
Las Vegas (LAS)	Pittsburg (PIT)
Chicago (ORD)	San Diego (SAN)
Philadelphia (PHL)	San Francisco (SFO)
Phoenix Sky Harbor (PHX)	Tampa (TPA)
Salt Lake City (SLC)	
Teterboro (TEB)	

3.4.2 Results

The overall comparison between Problematic and Baseline for each procedure variable analyzed is shown below in Figure 32. Unlike approach and departure procedures, the analysis showed that the average number of paths per procedure was not a factor for arrival procedures. However, there are many other variables for arrival procedures that appear to be statistically significant factors potentially contributing to operationally problematic charts.

First, the number of *altitude constraints* per path is significantly higher for the Problematic group compared to the Baseline group. The total number of altitude constraints, which includes *at or above*, *at or below*, or *mandatory* altitudes, for arrivals in the Problematic group is approximately 3.57 while arrivals in the Baseline group have approximately 0.67 ($t(22) = 3.07, P < 0.01$). This result may be largely due to the increased number of *mandatory*

altitude constraints for Problematic group (approximately 2.75) when compared with the mandatory altitudes for the procedures in the Baseline group (approximately 0.13) ($t(22) = 3.25, P < 0.01$) as shown in Figure 33.

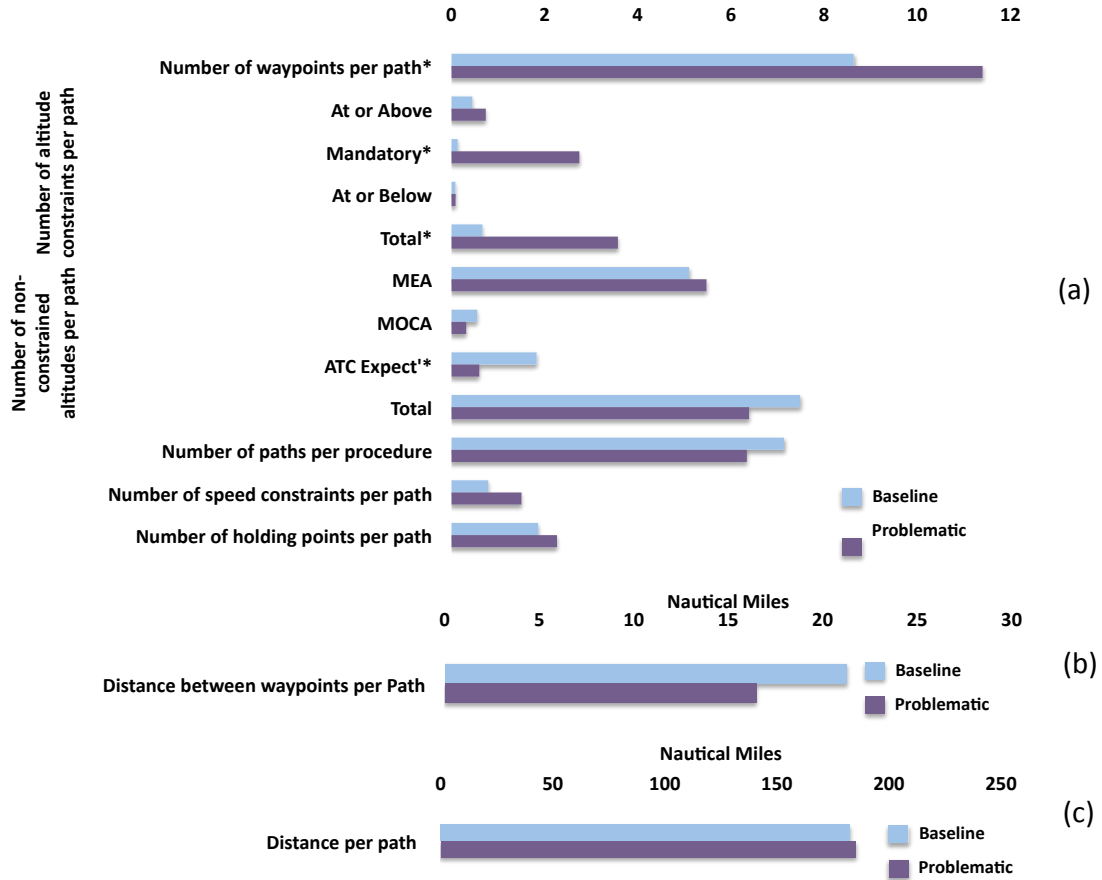

Figure 32. . List of chart elements reviewed for arrivals comparing Baseline Group with Problematic Group A) shows the average number of procedure elements B) and C) show the procedure elements related to distance

*Statistically significant for 95% confidence ($\alpha = 0.05$)

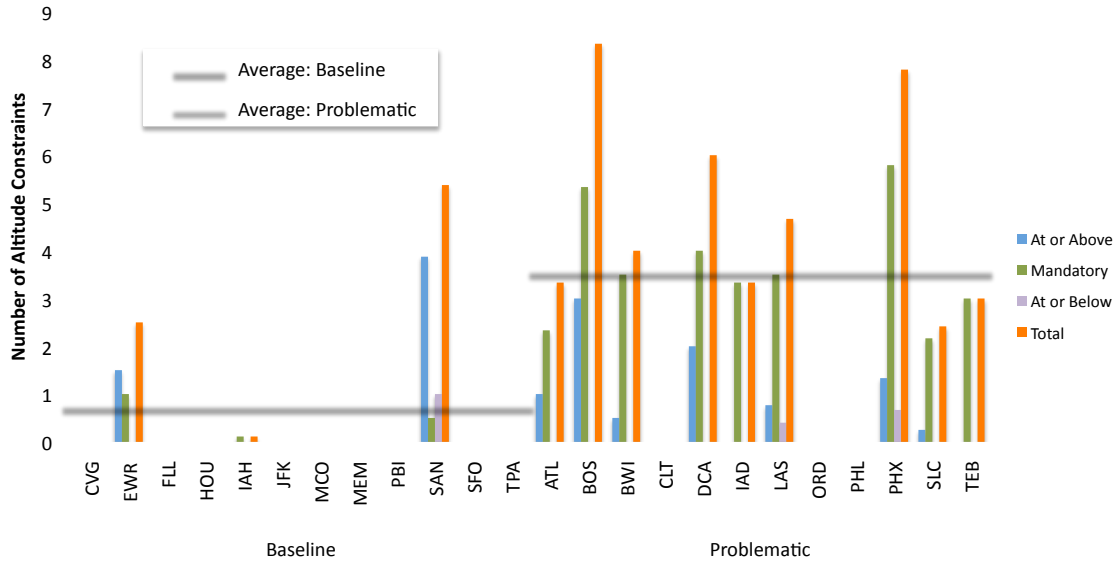

Figure 33. Average number of altitude constraints per path is shown for each airport categorized by Baseline and Problematic.

Second, the average number of ‘*ATC Expect*’ altitudes per path was significantly higher for the Baseline group than the Problematic group, contrary to the results seen with the altitude constraints. ‘*ATC Expect*’ altitudes are depicted on the procedure for pilot planning purposes. These altitudes are not considered crossing restrictions until verbally issued by the ATC. The average number of ‘*ATC Expect*’ altitude per path is approximately 1.82 for the Baseline group while it is approximately 0.60 for the Problematic group ($t(22) = 3.23, P < 0.01$) as shown in Figure 34.

Finally, arrivals in the Problematic group have a significantly higher number of waypoints per path compared to arrivals in the Baseline group ($t_{22} = 3.60, P < 0.01$). The average number of waypoints per path is 11.4 and 8.6 for the arrivals in the Problematic group and Baseline group respectively. The average across individual airports is shown in Figure 35.

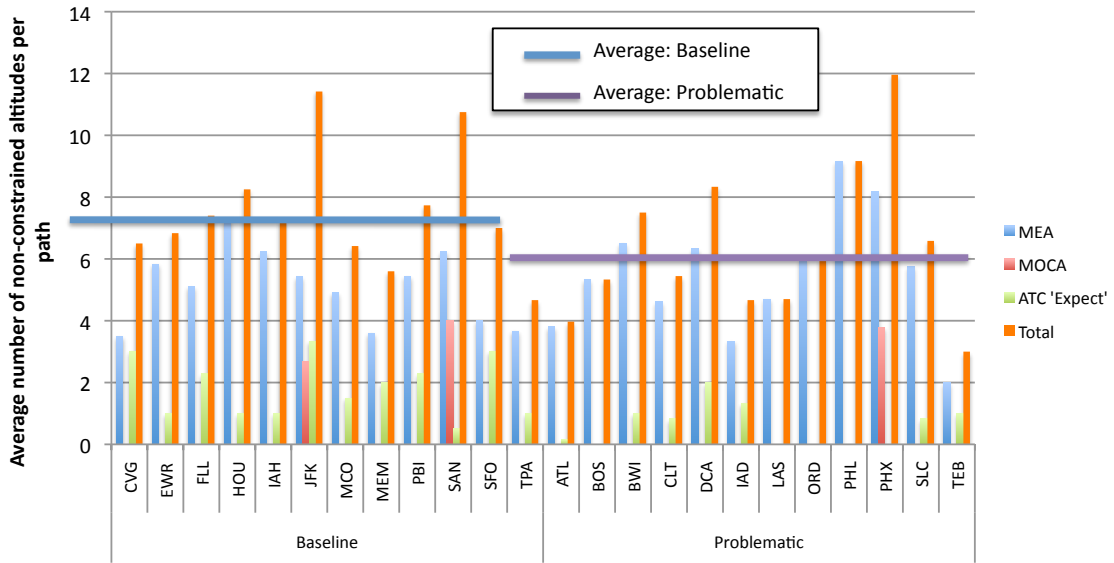

Figure 34. Average number of non-constrained altitudes per path is shown for each airport categorized by Baseline and Problematic.

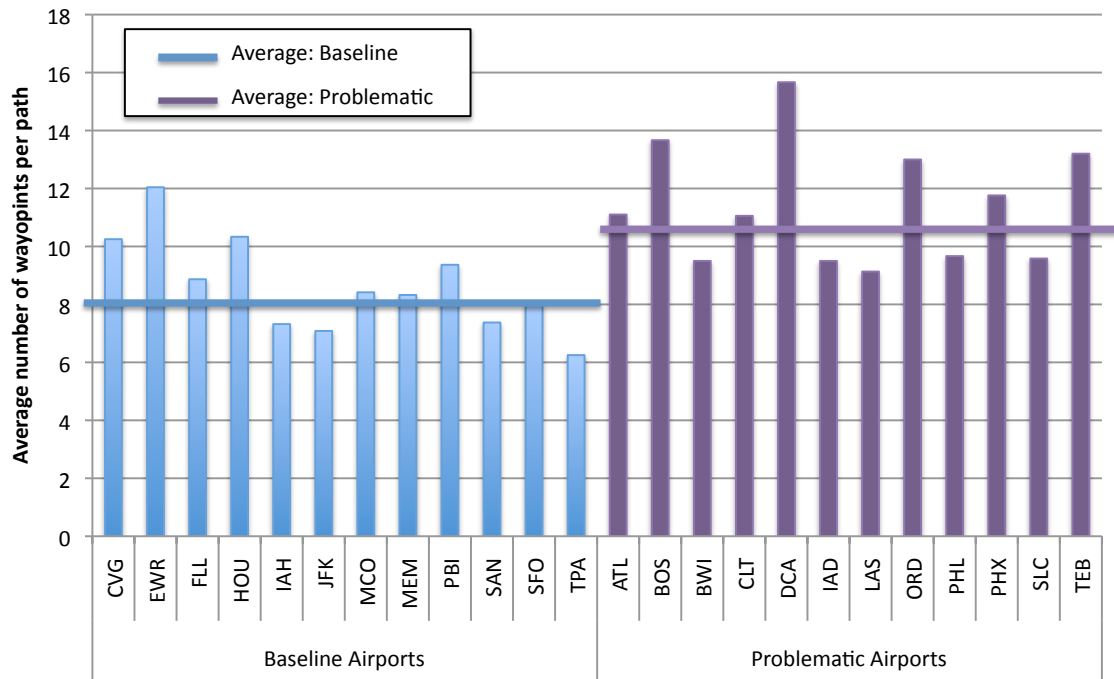

Figure 35. Average number of waypoints per path for arrival procedures is shown for each airport in the Problematic and Baseline group

3.5 Summary and Conclusions of Chart Review

Sixty-three approach, fifty-two departure, and fifty-four arrival procedures were analyzed. The procedures were selected based on a combination of industry discussions, ASRS report frequencies from Butchibabu et al [2010], and the top 35 OEP airports listed in the 2010 MITRE CAASD PBN capability reports.

An analysis of procedure variables was conducted for each individual flight paths. All procedure variables per path were recorded and compared. Factors that were associated with high levels of visual clutter included multiple flight paths per page for approach and departure procedures, and complex altitude constraints for arrivals. Multiple waypoints per path was also a factor for both arrivals and approaches. In addition, RF legs were an additional factor contributing to visual clutter for approaches.

Multiple flight paths are typically shown on the chart to depict all possible flight paths available to the pilot and ATC. However, once ATC has assigned a specific path to the pilot, all other paths may not need to be depicted unless ATC needs to vector the aircraft to another path for traffic separation or weather-related issues. Additionally, previous literature has found that as the amount of “irrelevant” information on display increases, visual search time to locate the target information also increases [Baker, 1960].

In addition, in cases where there were multiple paths, particularly multiple IFs, the profile view does not show the complete altitude profile beginning from IF or IAF. Instead, only the altitude profile for the last common segment was shown in the profile view. This was because there was not enough space to show multiple altitude profiles corresponding to the non-common path segments. When there was only one IF or IAF in the procedure, the full altitude profile beginning from that IF was shown in the profile view.

Chapter 4

Experiment Design of Separating Trajectories

Across Multiple Pages

4.1 Introduction

The Chart Review found that “Problematic” procedures had a significantly higher number of paths than the “Baseline” procedures. The increase in multiple flight paths could result in increased information depicted on the chart. One hypothesis is that this may correlate with the high levels of visual clutter on the chart.

In addition, due to the higher number of paths on the Problematic approach procedures, it was difficult to depict the vertical profile view for all paths. This resulted in incomplete profile views that began from either the IF or FAF (instead of IAF) for all procedures in the Problematic group, as discussed in Chapter 3. This is because depicting all paths on one profile view can result in ambiguity for the pilot in determining which path to use.

One approach to mitigate the potential adverse effects of multiple paths per chart is to reduce the number of paths depicted on one single chart. This can be done by separating paths depicted on one chart to a reduced set of paths on multiple charts. One clear advantage to this method is that less information is now shown on one chart, which potentially reduces visual clutter to improve the information search time to locate critical procedure variables on the chart. Another advantage is that for approach procedures, vertical profile can now begin from a common waypoint that has the potential to show more vertical path information. Examples of this are shown in Figure 36 and Figure 37.

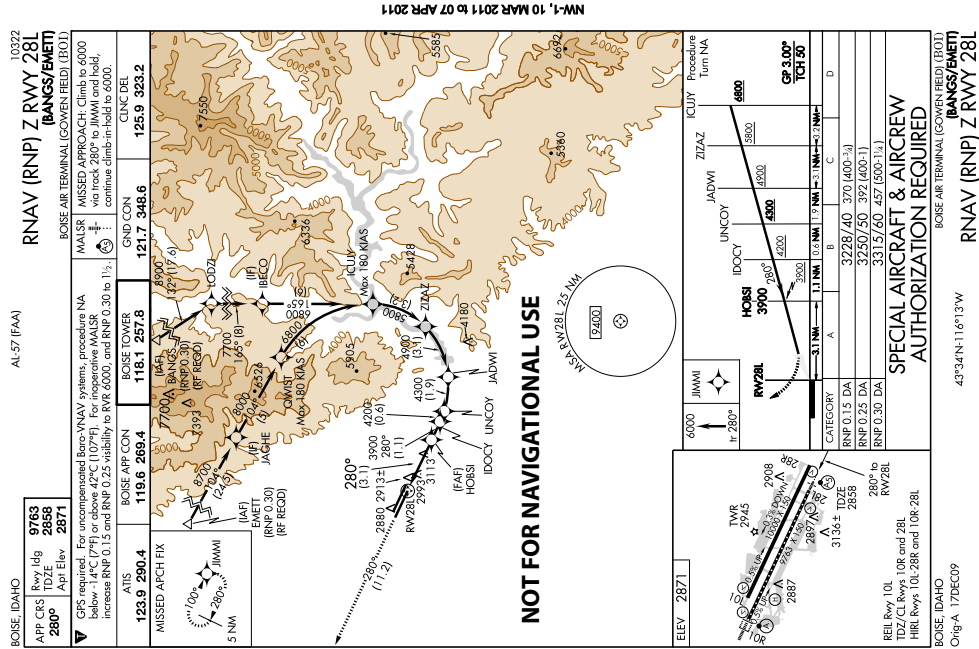

(b)

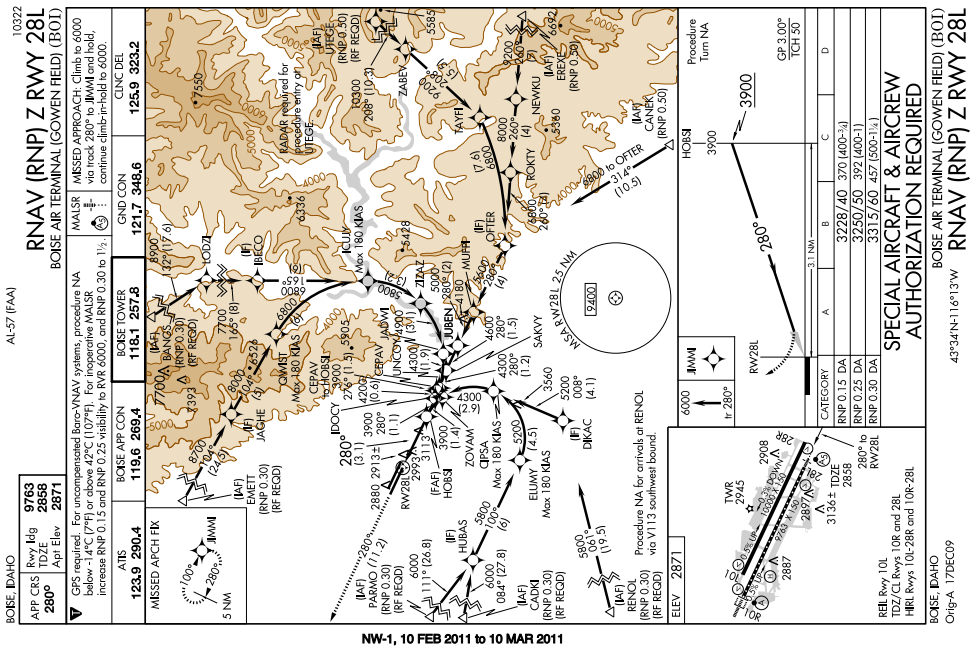

(a)

Figure 36. Example approach charts (a) current chart (b) modified chart

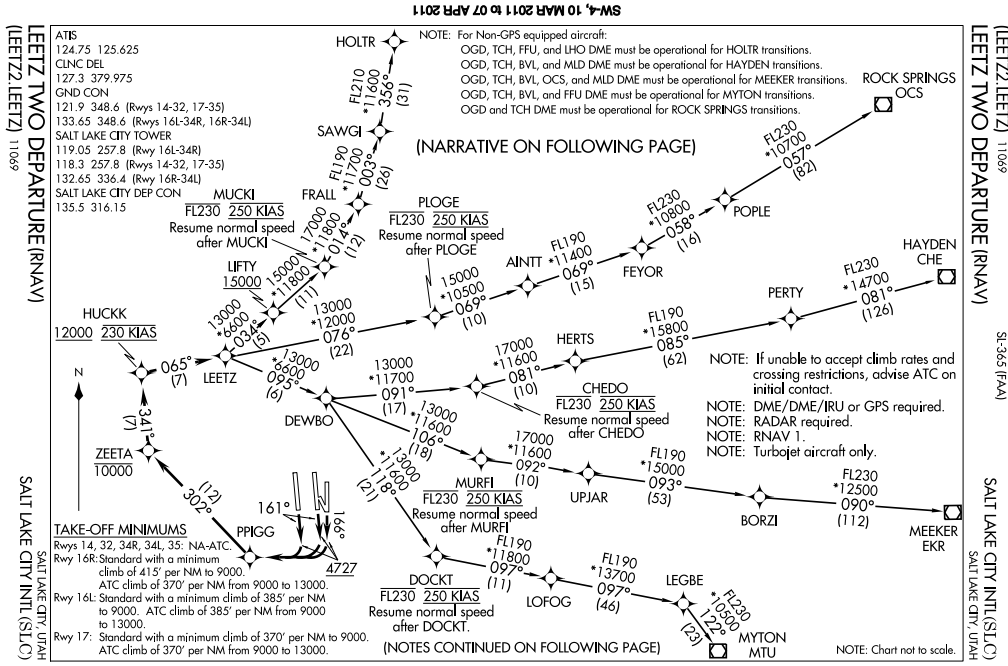

(a)

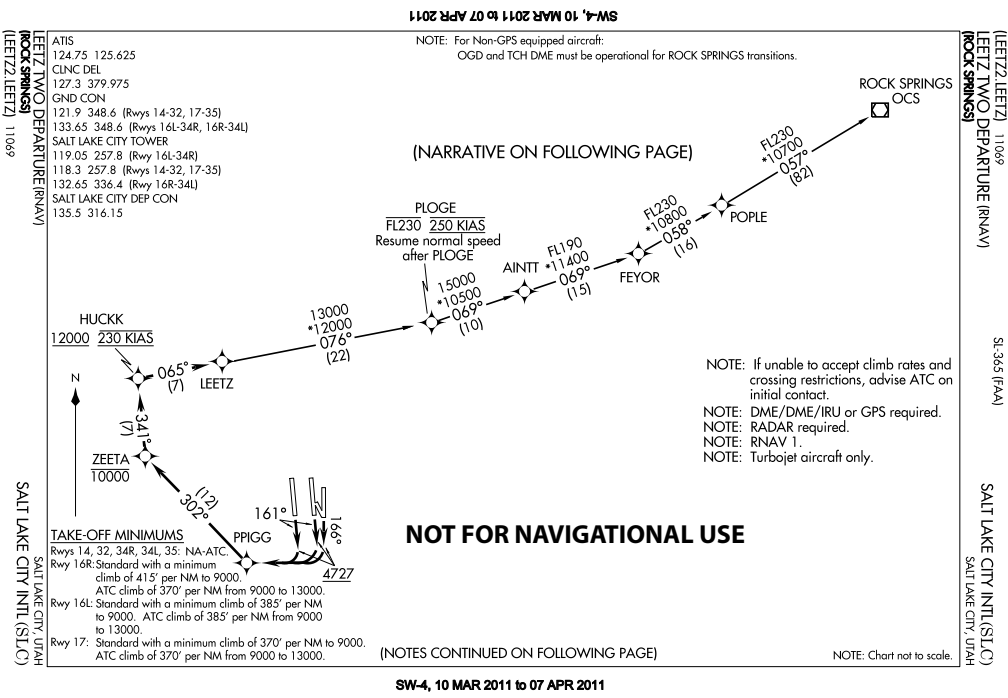

(b)

Figure 37. Example departure procedure (a) current chart (b) modified chart.

There are practical disadvantages to separating paths across multiple pages, however. These include having more paper to carry in the flight deck, the need for chart naming conventions for each chart in the set, and more time spent searching for the correct page within a set of multiple page charts. To mitigate the drawbacks associated with multiple page charts, one individual chart for every path is not created. Instead, paths that have many common segments are grouped. For approach procedures, paths converging prior to the IF are grouped together allowing for more information to be depicted on the profile views.

Modified Charts

Current Chart

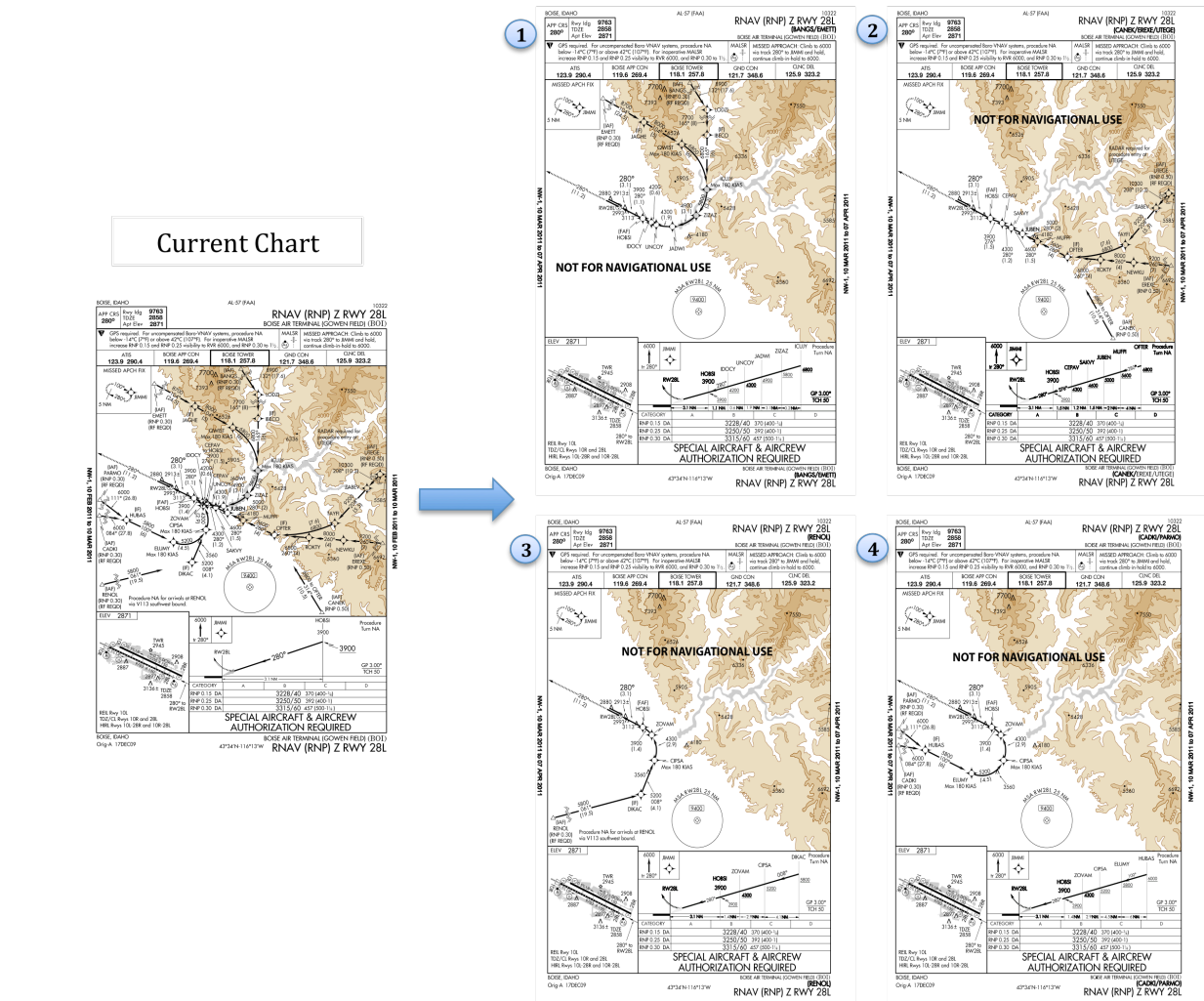

Figure 38. An example of modified approach chart for RNAV(RNP) Z RWY 28L, Boise Airport

An example for modified approach charts is illustrated in Figure 38. There are eight paths depicted for the Boise approach into Runway 28L as shown in Figure 36 (a). Four pages of this procedure were created after grouping paths with common segments together for the modified charts as shown in Figure 36 (b).

An example for departure procedures is illustrated in Figure 39 below. As seen, there are five paths for the departure from Salt Lake City, however only 3 pages were created as paths with common segments are grouped together.

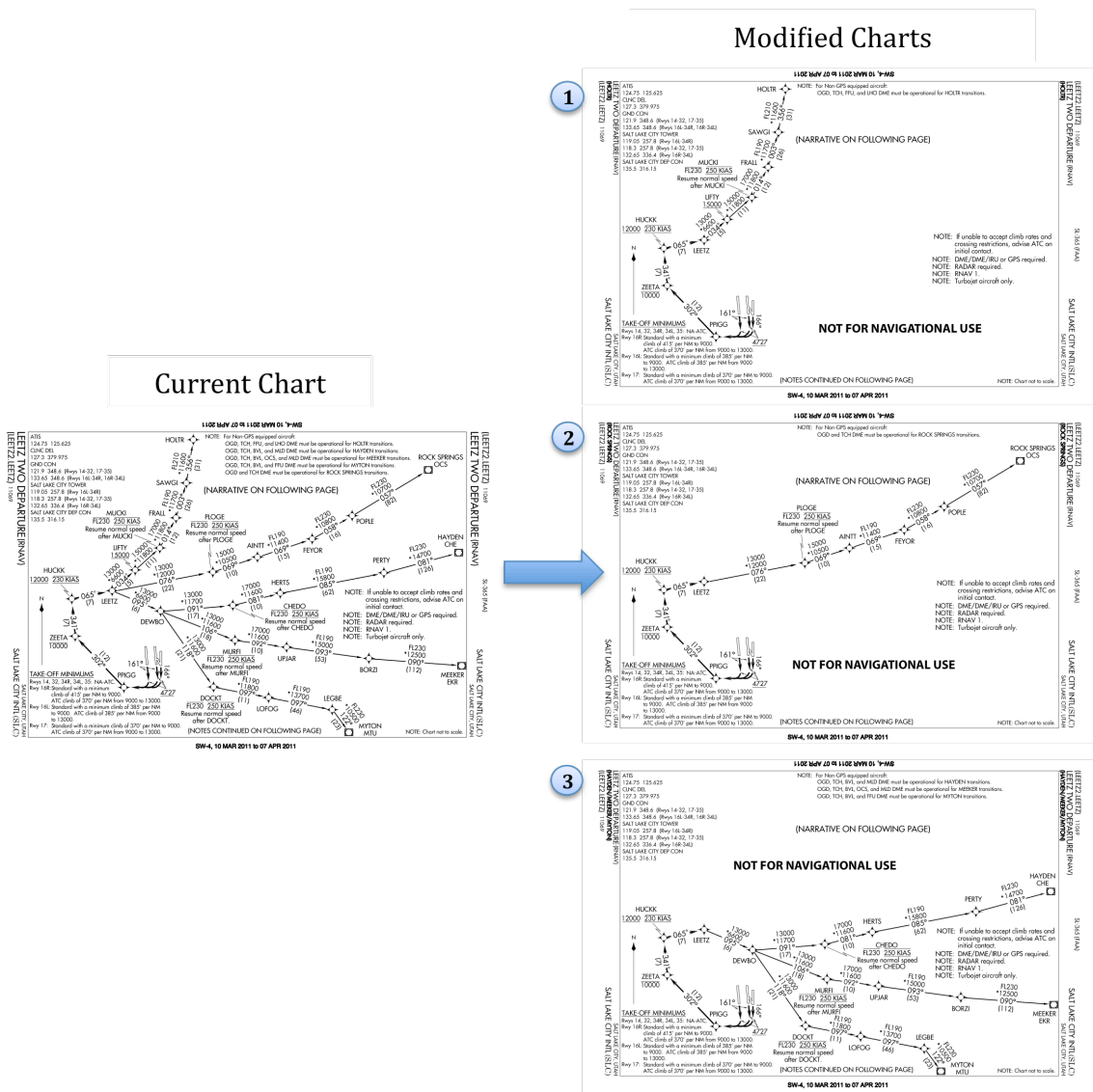

Figure 39. An example of modified charts for the graphical page of LEETZ TWO departure, Salt Lake City Airport

4.2 Multipage Modified Charts

To explore the idea of separating paths across multiple pages, a set of prototype charts were created based on the method described in Section 4.1. These charts were prototyped to contain only a limited number of paths per page and are referred to as “Modified” charts. Pilot performance using Modified charts was compared against the performance using “Current” charts.

Six procedures were modified into multi-page versions and two additional procedures (one RNAV RNP approach and one RNAV departure) were used for the practice trials in their current (original) format. Highly visually cluttered RNAV RNP approach and RNAV departure procedures were selected for the study to best examine the effect. Arrival procedures were not studied, as the number of paths per procedure was not a significant factor for arrivals contributing to operational issues as discussed in Chapter 3.

Of the six procedures modified, three were departures from DFW, SLC and LAS, and three were approach procedures from BOI, BZN and PSP. FAA AeroNav Products and Jeppesen prototyped the Modified charts in coordination with the experimenters. Each manufacturer modified the charts according to their own standard cartographic conventions to keep the charts as realistic as possible. Table 10 shows the number of Current and Modified charts tested in the study.

Figure 36 through Figure 39 show example cases for Current and Modified charts in the FAA chart version. Example cases for charts created using Jeppesen chart version are presented in Figure 40 and Figure 41. Minimal changes were made to the format of the charts. In addition to removing paths that do not share common segments, notes and information unrelated to the charted paths were also removed. In the graphical description of the route in the current charts, there were several paths that were discontinuous and arrows were used to indicate where the path would connect. This is a technique used by chart manufacturers to minimize overlapping of path and hence, information related to the path. For the modified charts however, paths that were previously discontinuous were extended when possible as a result of the deletion of some paths. Zooming and re-centering could further optimize the charts with the additional whitespace gained after removing information, however no such changes to the format of the chart were made.

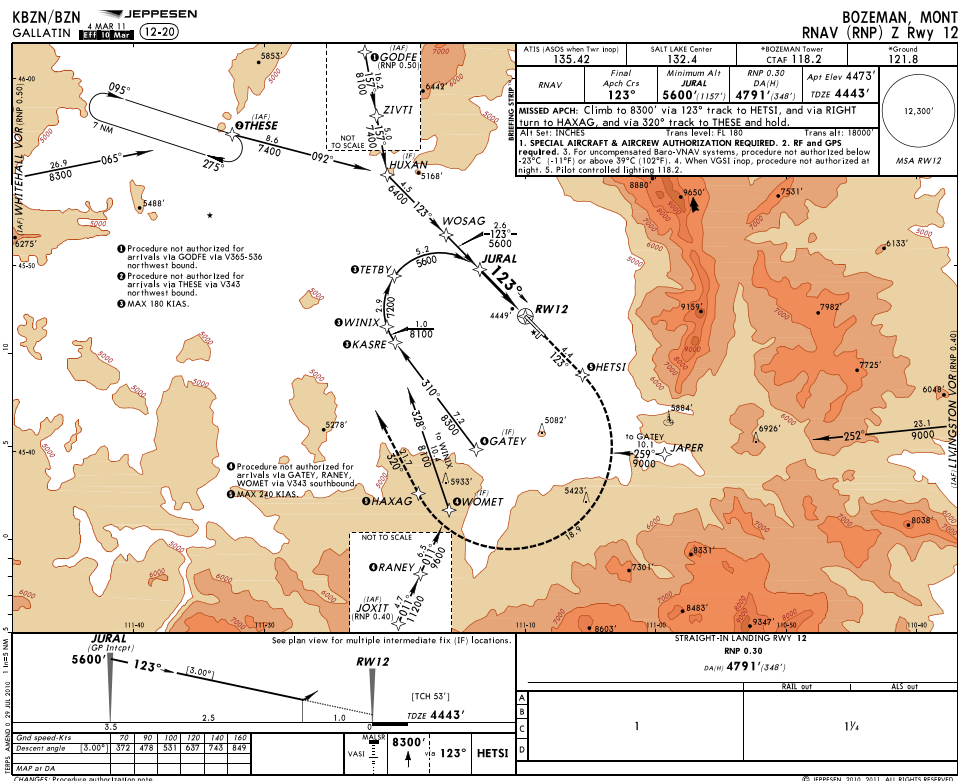

(a)

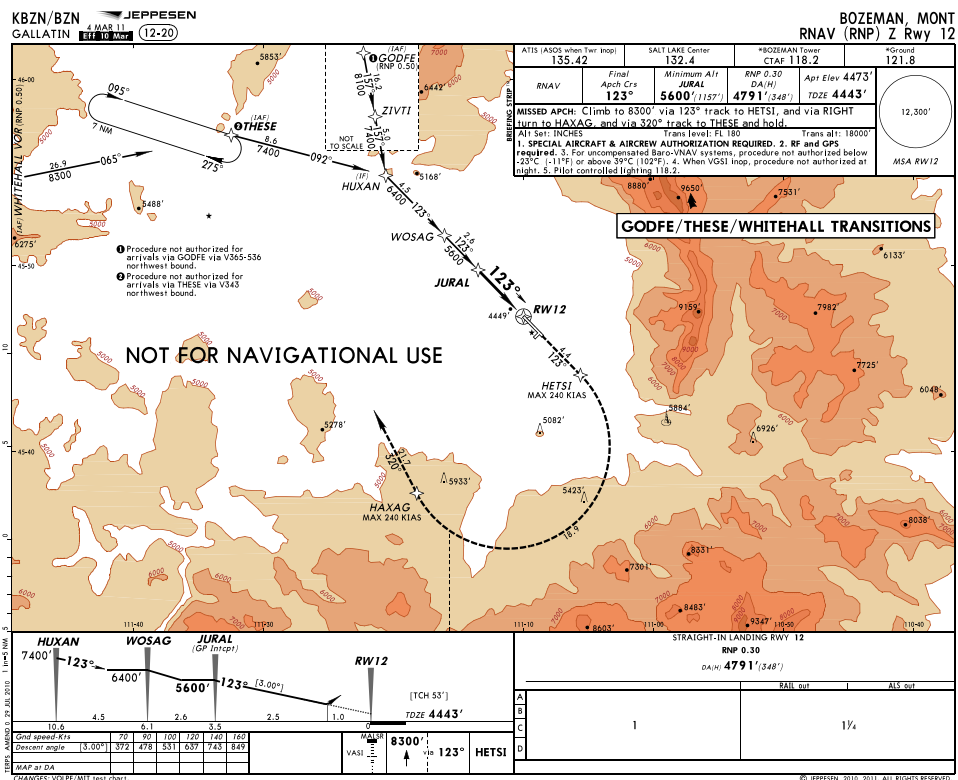

(b)

Figure 40. Example Jeppesen approach procedures (a) Current chart (b) Modified chart

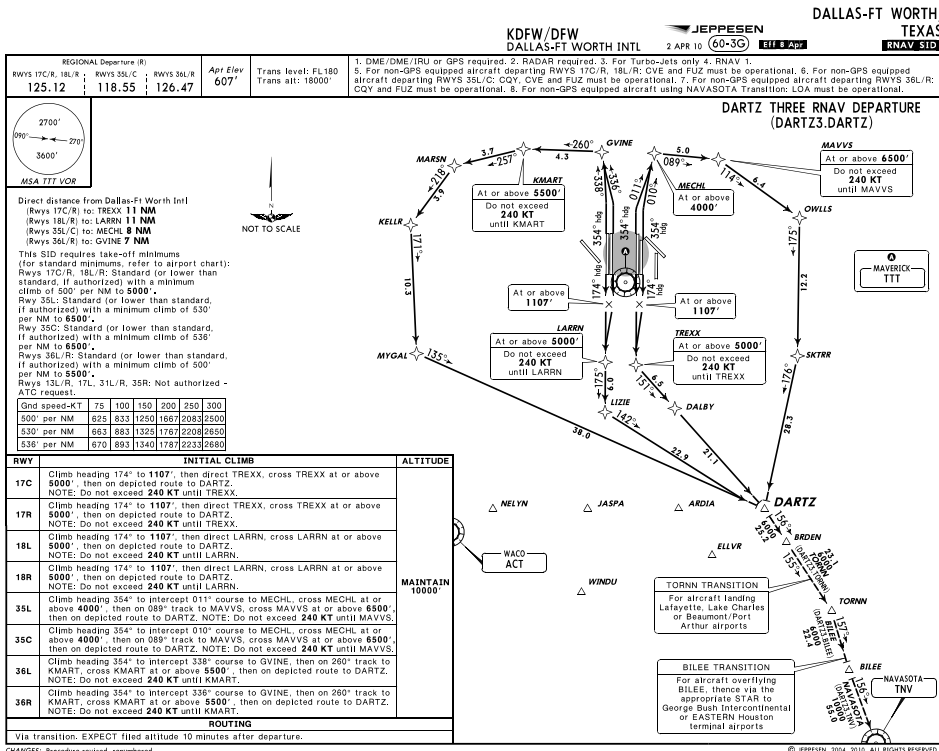

(a)

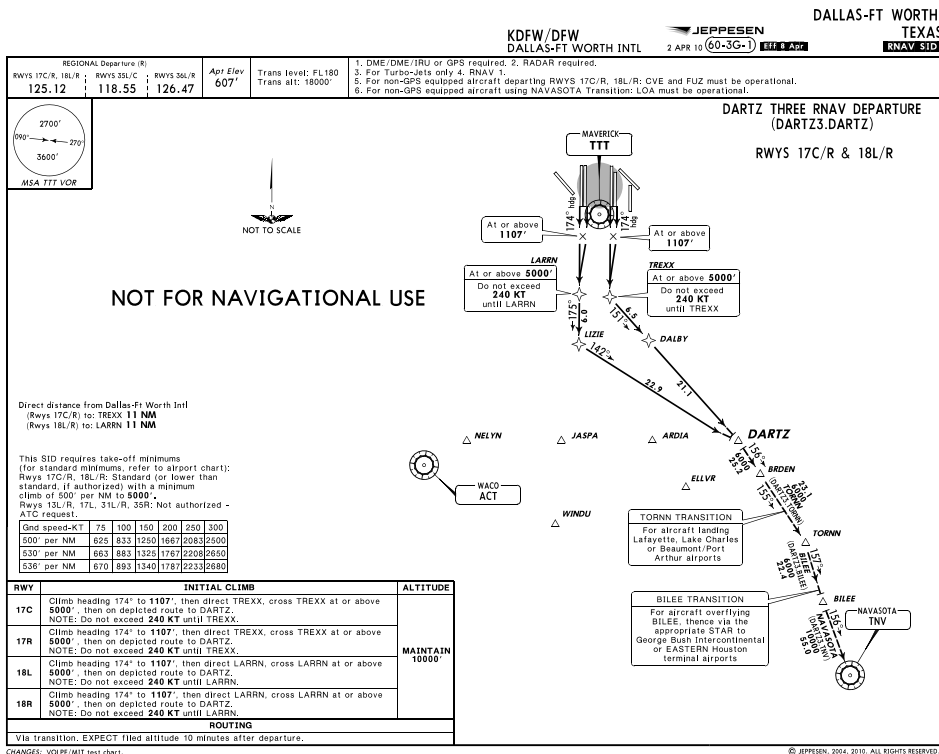

(b)

Figure 41. Example Jeppesen departure procedures (a) Current chart (b) Modified chart

In addition, no changes were made to the original titles of the procedures. However, in order to distinguish the individual pages of the modified charts, distinct names were assigned to each page. For approach procedures, IAF names of each path were assigned. For departure procedures, transition fixes or runway names were assigned. The names were ordered alphabetically (or chronologically for runway names) within each group.

Each chart manufacturer placed these assigned chart names in different areas of the chart based on their standard cartographic conventions. FAA AeroNav chart manufacturers placed the assigned chart name under the original title at the top of the page as shown in Figure 36 (b) with the title “BANGS/EMETTE” and Figure 37 (b) with the title “ROCK SPRINGS”. Jeppesen chart manufacturers inserted the chart names in the plan view for approach procedures as shown in Figure 40 (b) with the title “GODFE/THESE/WHITEHALL” and near the graphic description of the route for departure procedures as shown in Figure 41 (b) with the title “RWYS 17C/R 18L/R.” Regardless of the chart manufacturer, the same names were assigned to both FAA and Jeppesen charts.

Table 10. List of procedures tested and the number of pages in modified charts compared to current charts

Type	Airport	Code	Procedure Name	Pages in FAA Charts		Pages in Jeppesen Chart	
				Current	Modified	Current	Modified
Approaches	Boise, Idaho	BOI	RNAV (RNP) Z RWY 28L	1	4	2**	5**
	Bozeman, Montana	BZN	RNAV (RNP) Z RWY 12	1	3	1	3
	Palm Springs, California	PSP	RNAV (RNP) Y RWY 31L	1	3	1	3
Departures	Dallas-Fort Worth, Texas	DFW	DARTZ THREE	2*	4*	1	2
	Las Vegas, Nevada	LAS	SHEAD SEVEN	2*	4*	1	2
	Salt Lake City, Utah	SLC	LEETZ TWO	2*	6*	1	3
* FAA departure charts have an additional “Narrative” page							
** Jeppesen Approach chart has an additional “Final Approach” page into Boise airport for runway 28L							

4.3 Information Retrieval Task

In order to determine whether pilot performance improved using Modified charts compared to Current charts, an information retrieval experiment was conducted. An information retrieval task performance is a common measure utilized in previous literature to determine pilot performance with charts and maps [Teichner and Mocharnuk (1979), Osbourne et al (1992), Osbourne et al. (1995), and Mykityshn et al. (1991)]. This information retrieval task incorporated a visual search task by asking pilots several questions. The information retrieval performance (i.e., time taken to answer the questions and the accuracy of the answers) was then measured and compared between the current and modified charts.

The information retrieval task was designed to evaluate response time and accuracy for a pilot to search and retrieve information from a chart for a given question. Each pilot was shown both Current and Modified formats of the chart, however the order in which each chart was shown was randomized. The specific study protocol and experiment design is outlined in Section 4.3.

A computer presentation was chosen for the study so that more accurate response time could be achieved. Although the paper-based display could provide higher face-validity for the paper charts, the focus of the experiment was the chart format and understanding the benefits of the de-cluttering technique of removing paths from charts. The results of the experiment could potentially be useful for future design of paper charts, as well as data-driven electronic charts.

The computer simulation was developed using a MATLAB GUI. An example screenshot and description of the task is presented below in Figure 42. The task was presented on a monitor with high resolution (1680 pixels by 1050 pixels), which showed the charts in their original size. In addition to the monitor, all participants were given a standard keyboard and mouse for experiment use. Figure 42 shows labels on an example screen shot from the experiment.

Prior to beginning each experiment session, subjects had the option to take the test using Jeppesen or FAA AeroNav Products charts.

- 1 Chart
- 2 Pseudo-ATC Clearance
- 3 Information Retrieval Question
- 4 Procedure Type & Trial Number
- 5 Action Buttons

2 You are cleared to Boise Air Terminal (BOI) for the RNAV (RNP) Z RWY 28L via PARMO

3 What is the maximum allowed speed at ELUMY?

4 / 56

4

5

Figure 42. An annotated example screenshot of the experiment display

Experiment display for each chart type (i.e., Jeppesen, FAA AeroNav Products) and procedure type (i.e., approaches, departures) vary slightly (Sample Screenshots are shown in Appendix H). If the chart was composed of more than one page (e.g., if there was a second page), the pilot had the option to toggle between the pages using the control buttons (“Graphical” and “Narrative Notes” for FAA departures and “Transition” and “Final Approach” for Jeppesen approaches). The labeled buttons were named according to what the pages are titled on the charts.

Each trial required pilots to look at one chart in Current or Modified format and answer one questions associated with the chart presented. The flow diagram of each trial is presented in Figure 43. In the beginning of the experiment, pseudo-ATC clearance and an information retrieval question (two gray bars, #2 and #3 in Figure 42) associated with a chart are presented to the pilot (Figure 44). The pseudo-ATC clearance was shown so that the pilots could get an orientation for which procedure and flight path s/he was “flying” to retrieve

information related to the path. Details regarding the different types of information retrieval questions are discussed in section 4.3.1.

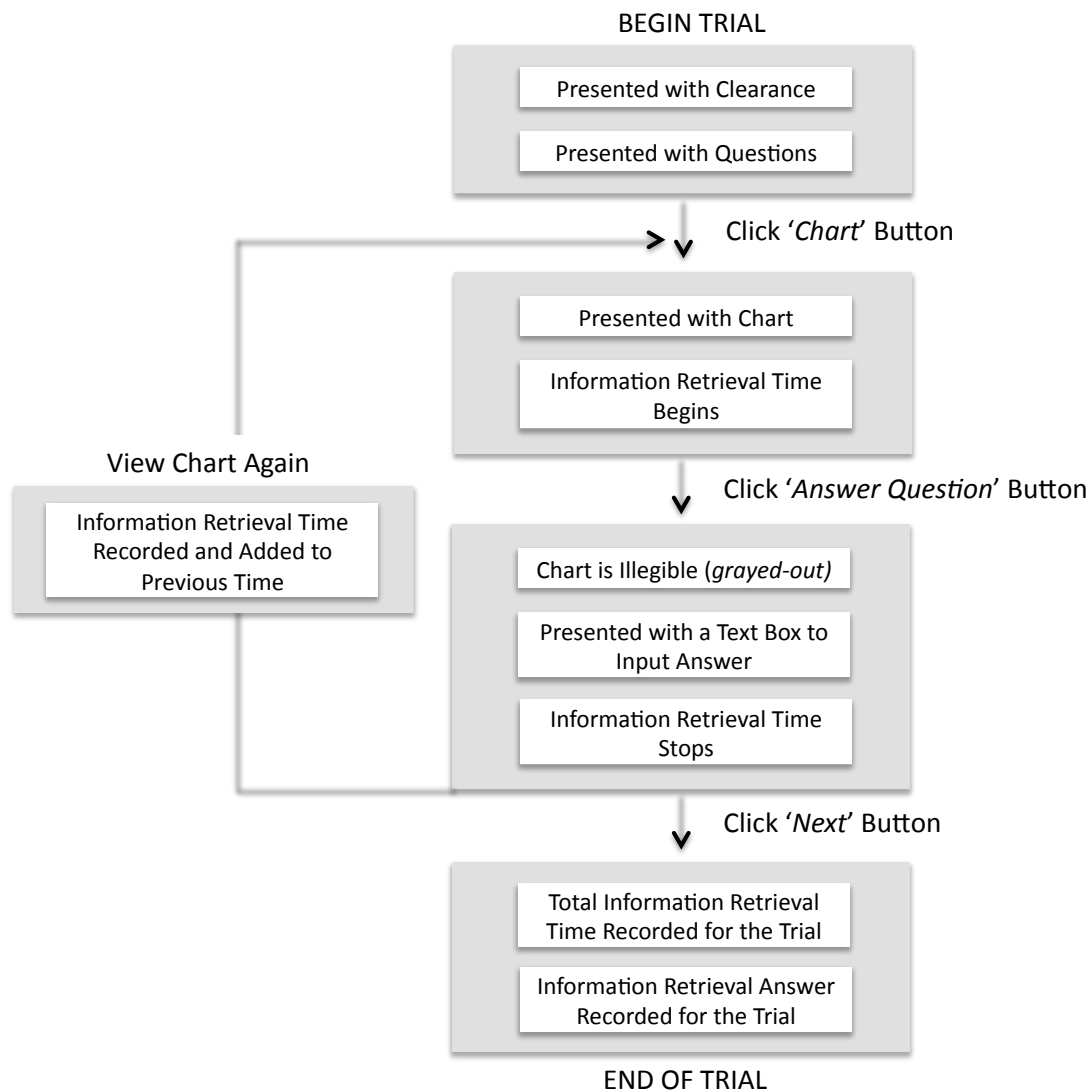

Figure 43. Flow Diagram of Each Trial

As seen from Figure 42, there are three action buttons (#5) to the right of the question. In order to view the chart after reading the clearance and the questions, the subjects click on the “Chart” button to make the chart visible (Figure 45). The amount of time the chart was visible was recorded and is defined as the response time to locate and extract the desired information from the chart. As such, a “faster” response time was used as an indicator of the ease with which information could be extracted from each chart.

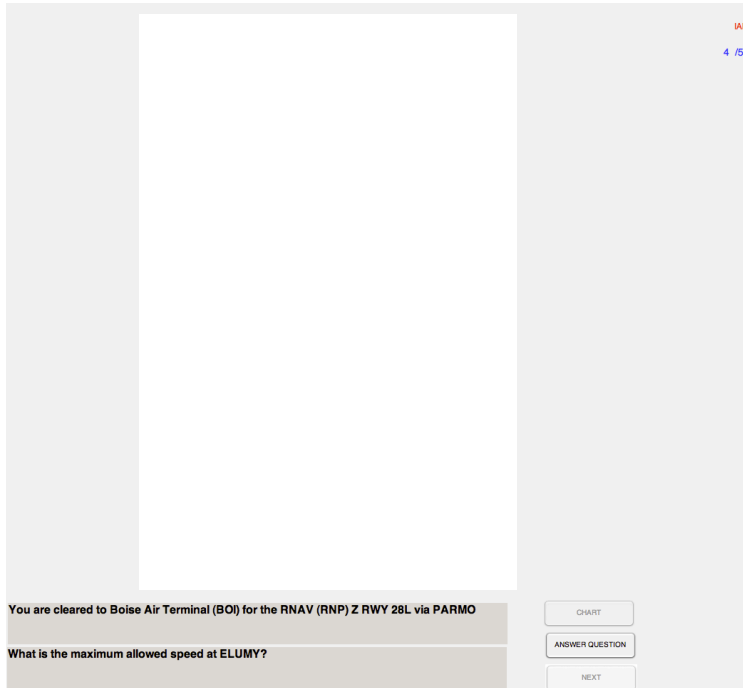

Figure 44. An example screenshot of the experiment display from the beginning of a trial is shown, where a clearance and question is shown to the pilot without the chart.

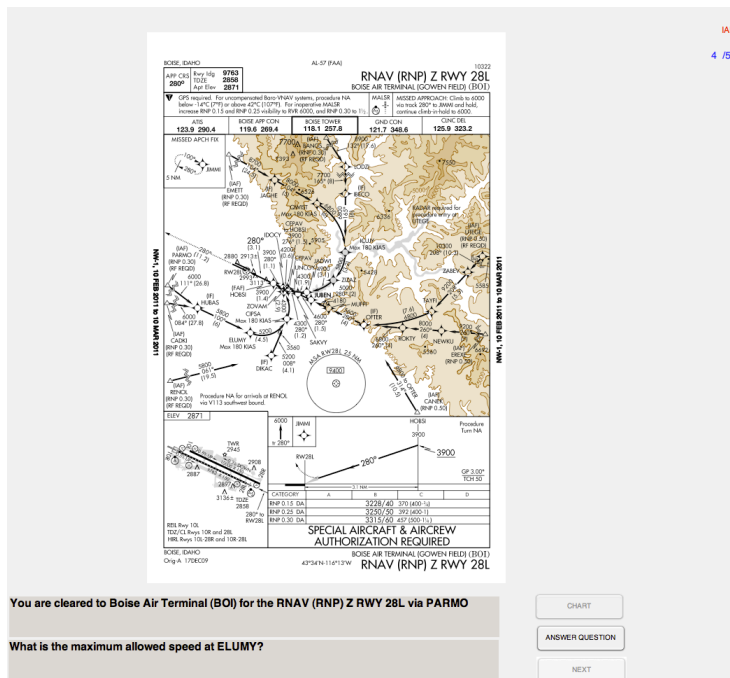

Figure 45. An example screenshot of experiment display after "Chart" button is clicked is shown. Pilots are presented with the chart along with the clearance and question.

After retrieving the information, subjects were instructed to click on “*Answer Question*” button (#5) to type the answer to the question. When the “answer question” button was enabled, the chart was grayed out, prohibiting the pilot from viewing the chart (Figure 46). If the pilot wanted to view the chart again, s/he could press “*Chart*” which would make the chart visible once again as illustrated in Figure 43. The total of the times the chart was visible was recorded as the reaction time to retrieve information from the chart. After answering each question, subjects were instructed to click on “*Next*” to proceed to the next question.

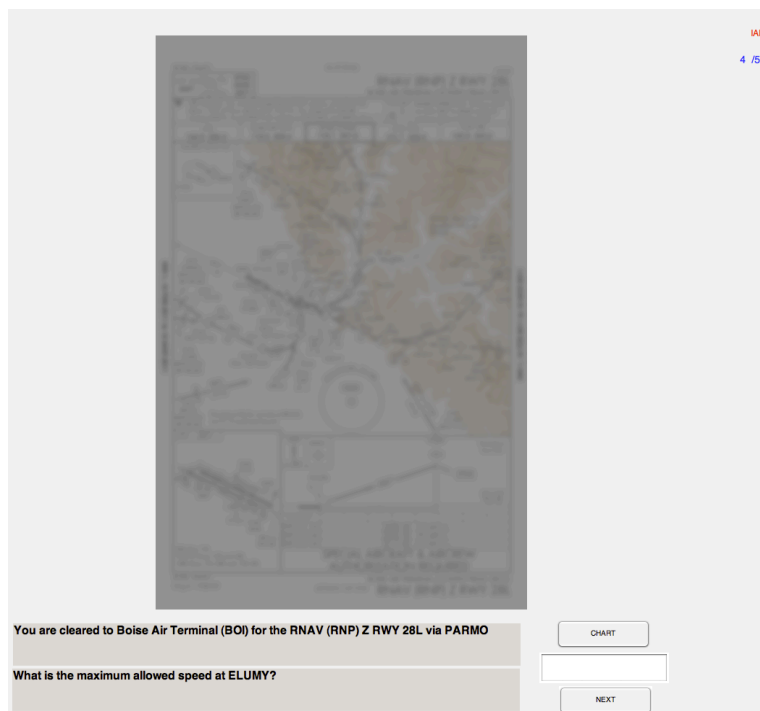

Figure 46. An example screenshot of experiment display after "answer question" button is clicked is shown. Pilots are shown a grayed-out chart and an input text box along with the clearance and question.

In addition to response times to retrieve information, responses to questions were also recorded and scored for accuracy. The response times and accuracy for each chart type and procedure type were evaluated separately. The results of the task are shown in Chapter 5.

4.3.1 Information Retrieval Question

Each trial in the information retrieval task involved answering one question corresponding to one chart. The questions were equally divided between current and modified charts. For each question pertaining to a specific path on a current chart, there was a corresponding question for the modified chart. For example, Boise airport had a total of 24 questions; 12 questions for current and 12 for modified charts.

There were two main types of questions asked: “Path-Specific” and “General”. Path-Specific questions pertained to any one path on the chart (e.g. altitude constraints, heading), while General questions pertained to information that was common among all paths (e.g. communication frequencies, airport elevation) Within path-specific questions, there were five types of questions asked about the path: distance, track, speed, altitude, and notes.

Sample questions for RNAV (RNP) Z RWY 28L IAP into Boise Airport for both Path-Specific and General question are described in the Table 12 below. Answers to each question can be retrieved from Figure 11 and Figure 12. Sample questions for RNAV SHEAD SEVEN departure procedure out of Las Vegas Airport are shown in Table 13 below. Answers to these questions can be retrieved from Figure 7.

Table 11. Sample questions for approach procedure into Boise Airport.

Question Type	Clearance	Question
DISTANCE	You are cleared to Boise Air Terminal (BOI) for the RNAV (RNP) Z RWY 28L via BANGS	What is the distance from JADWI to UNCOY?
TRACK	You are cleared to Boise Air Terminal (BOI) for the RNAV (RNP) Z RWY 28L via EREXE	What is the track from NEWKU to ROKTY?
SPEED	You are cleared to Boise Air Terminal (BOI) for the RNAV (RNP) Z RWY 28L via PARMO	What is the maximum allowed speed at ELUMY
ALTITUDE	You are cleared to Boise Air Terminal (BOI) for the RNAV (RNP) Z RWY 28L via CADKI	What is the minimum altitude required from ZOVAM to HOBSI?
NOTES	You are cleared to Boise Air Terminal (BOI) for the RNAV (RNP) Z RWY 28L via UTEGE	Other than GPS, what other equipment is required for procedure entry of UTEGE?
GENERAL (Inside)	You are cleared for Boise Air Terminal (BOI) for the RNAV (RNP) Z RWY 28L via BANGS	What is the missed approach hold fix?
GENERAL (Outside)	You are cleared to Boise Air Terminal (BOI) for the RNAV (RNP) Z RWY 28L via CADKI	What is the length of the landing runway?

Table 12. Sample questions for departure procedure out of Las Vegas Airport.

Question Type	Clearance	Question
DISTANCE	You are cleared to depart from Las Vegas/Mc Carran International (LAS) via SHEAD SEVEN departure via RWY 7L	What is the distance from MINEY to HITME?
TRACK	You are cleared to depart from Las Vegas/Mc Carran International (LAS) via SHEAD SEVEN departure via RWY 25L	What is the track from PIRMD to ROPPR?
SPEED	You are cleared to depart from Las Vegas/Mc Carran International (LAS) via SHEAD SEVEN departure via RWY 1L	What is the required maximum speed until BESSY?
ALTITUDE	You are cleared to depart from Las Vegas/Mc Carran International (LAS) via SHEAD SEVEN departure via RWY 19R	What is the altitude window constraint at ROPPR?
NOTES	You are cleared to depart from Las Vegas/Mc Carran International (LAS) via SHEAD SEVEN departure via RWY 7L	What is the minimum climb gradient required after departing runway 7L?
GENERAL	You are cleared to depart from Las Vegas/Mc Carran International (LAS) via SHEAD SEVEN departure via RWY 19L	What is the tower frequency for your cleared runway?
DISTANCE	You are cleared to depart from Las Vegas/Mc Carran International (LAS) via SHEAD SEVEN departure via RWY 7L	What is the distance from MINEY to HITME?

On approach charts, a distinction was made between general questions that were inside the planview and those outside of the planview. This distinction was made since the chart modifications to the planview would affect the information retrieval for both General and Path Specific questions inside the planview. Sample questions for Inside Planview and Outside Planview questions are shown in Table 11.

The total number of information retrieval questions presented to each pilot based on procedure type (approach or departure), airport, and question type is described in Appendix A below. The full list of questions and clearances presented to the pilot are shown in Appendix A.

4.4 Study Protocol

Figure 47 shows a schematic of the experiment procedure. At the start of the experiment, each participant was given introductory materials (Appendix E). These materials included an introduction to the study, informed consent form, and background questionnaire. The introduction to the study outlined an overview of the study including the purpose and potential outcome of the study. The informed consent form presented the experiment procedure, potential risks and discomforts, potential benefits, and the rights of research subjects. In addition, the consent form stated the confidentiality agreement, where subjects are told that no individual names and identifies will be recorded with any data or released in any reports. After presenting the consent form, subjects were allowed to withdraw from the experiment if they chose to do so. If they chose to continue with the study, a background questionnaire was presented in which the subject's familiarity with RNAV and RNP procedures and other relevant information about their flight experience was recorded.

As shown in Figure 47, the information retrieval task was then presented to the pilot. Before beginning the task, written instructions were provided on paper to be read (Appendix E). The instructions requested the pilots to respond to the questions as quickly and as accurately as possible. In addition, the instructions explained how the task is structured, specifically, that there are two blocks with a rest period between the blocks. The task was designed such that one block was for approaches while the other was for departures. The order of the two blocks was counterbalanced between subjects.

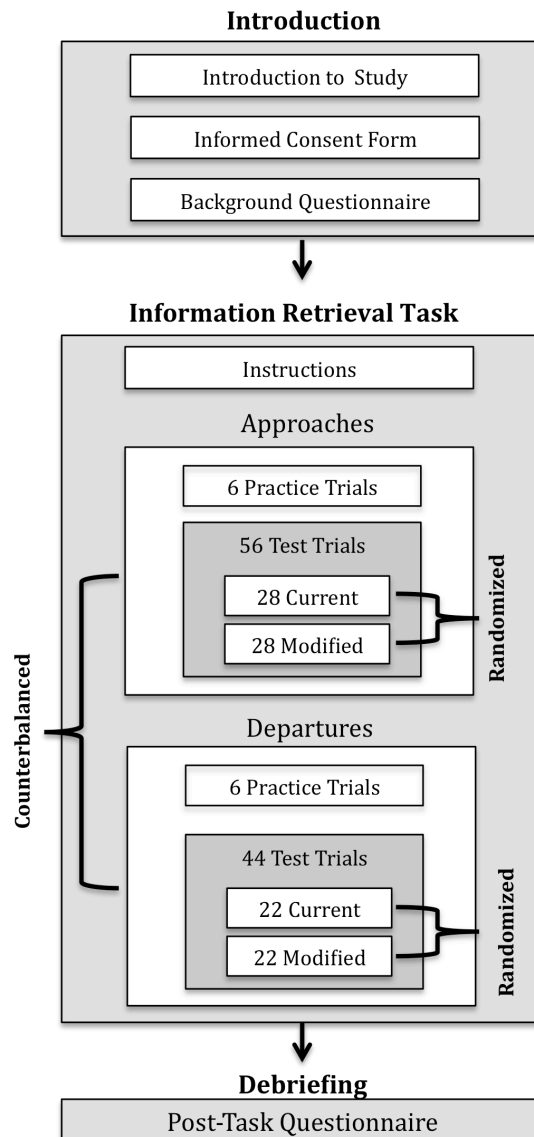

Figure 47. Flow diagram of the Study Protocol

The approach block contained 56 test trials and the departure block contains 44 test trials. Each test trial consisted of answering one question to one presented chart. Within each block, the two chart formats (Current and Modified) were presented in a randomized order. Half of the questions in each block pertained to the current chart while the other half pertained to the modified chart. The chart format is a within subject variable, where each participant answered questions about both Current and Modified charts.

The study concluded with a post-task questionnaire shown in Appendix F. Here, pilots were asked to provide feedback about the experiment and provide any issues encountered when flying RNP approach procedures in their daily operations.

Chapter 5

Experiment Results and Discussion

5.1 Participants

A total of 47 pilots volunteered to participate in the study. Participants were professional pilots from corporate or airline operators in the United States. All subjects were current and licensed instrument-rated pilots. All pilots also had RNP qualification, meaning that the pilot was trained to meet the Authorization Requirement (AR) appropriately to fly these procedures [AC 90-101]. The flight time for all pilots ranged between from 2,200 hours to 24,000 hours, with an average of 11,484 hours. See Table 13 for details regarding the pilot experience and background. Note that 7 airline instructor pilots from a large airplane manufacturing company are included in the Airline Pilot group.

Table 13. Participant's Experience and Background

	Average Flight Hours	Instructors/ Check Airman	Average number of procedures flown in the last active month	
			RNAV (RNP) IAP	RNAV SID
Airline (N = 28)	12,476	14	2.6	3.4
Corporate (N = 19)	10,179	1	2.0	2.7
Total (N = 47)	11,484	15	2.3	3.1

All pilots received simulator training on RNAV procedures within the last 12 months. Table 13 shows the average number of procedures flown in the last active month and the types of RNAV (RNP) approach procedures flown by the pilots on average.

Prior to beginning the experiment, pilots were requested to rate their comfort levels with RNAV departure procedures and RNAV (RNP) approach procedures. Figure 48 shows the score pilots gave on how comfortable they felt with RNAV (RNP) approaches and RNAV departures. For approaches, 34 pilots (72%) rated their comfort level as 4 or 5. For departures, 33 pilots (70%) rated their comfort level as 4 or 5. Out of 47 pilots, 3 pilots have never flown RNAV (RNP) approaches in line operations.

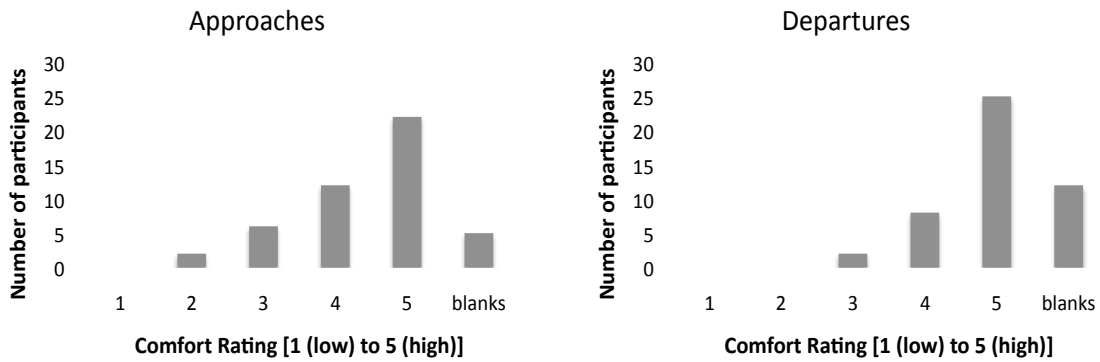

Figure 48. Comfort level for RNAV (RNP) approaches and RNAV departures rated by participants on a scale of 1 (low) to 5 (high).

Table 14 describes the pilot experience at airports from which the procedures for the study were selected. Pilot experience may vary based on the airports most commonly flown by the airline or corporate facilities volunteered in the study.

Table 14. Participants' flight experience at the airports from which the procedures were selected for the experiment

	Airport (airport code)	Airline (N = 28)	Corporate (N=19)	Total (N= 47)
RNAV (RNP) IAP	Boise Air Terminal (BOI)	1	0	1
	Bozeman/Gallatin Field (BZN)	0	0	0
	Palm Springs Intl. (PSP)	13	2	15
RNAV SID	Dallas/Fort Worth Intl. (DFW)	9	3	12
	McCarran Intl. (LAS)	15	7	22
	Salt Lake City Intl. (SLC)	1	5	6

5.2 Accuracy

Each pilot was asked a total of 98 information retrieval questions as discussed in Chapter 4. Each question was graded for accuracy. In general, pilots answered all questions correctly. Overall accuracy across all 47 participants was 99.5% where 34 pilots answered all 98 questions correctly. The lowest score was 94.9% where the pilot missed 5 out of the 98 questions. Comparing pilots' accuracy for IAPs and SIDs between current and modified chart, no systematic trends were found. Also, no effect was found between the chart manufacturer types (FAA vs. Jeppesen), or pilot types (Airline vs. Corporate).

5.3 Response Time

Figure 49 below shows the overall response times across all 47 participants. The average response time for pilots using Modified charts was significantly faster compared to pilots using Current charts. For approaches, the mean response time for current charts was 16.9 seconds while for modified charts was 10.6 seconds. For departures, the mean response time for current charts was 16.2 seconds compared to 13.2 seconds for modified charts. Note that the error bars displayed in the figure represent standard error, which are all less than one second.

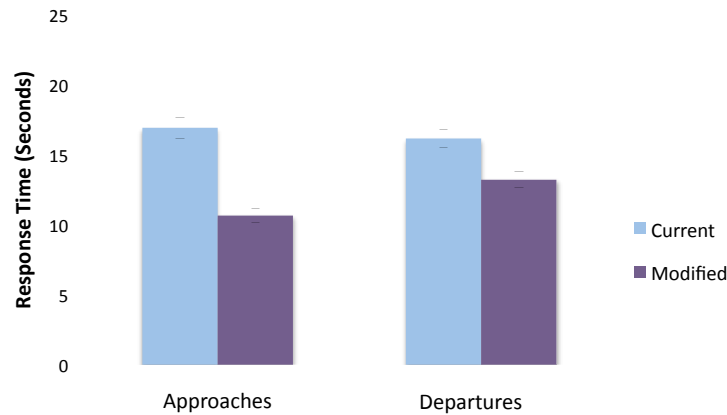

Figure 49. Average response times for Current and Modified charts for each procedure type.

Two-tailed paired t-tests were conducted on the logarithm of response times of Current and Modified charts to account of the skew in the data. Table 15 shows the results of the analysis. For all analysis, departures and approaches were analyzed separately.

Table 15. Statistics for each procedure type comparing Current and Modified charts.

	Current (Seconds)	Modified (Seconds)	Statistical Testing
IAP	22.7	13.5	$t(46) = 9.39, p < 0.01$
SID	11.8	10.3	$t(46) = 3.31, p < 0.01$

As seen from Table 15, the overall effect of removing paths per chart has reduced mean response time for approach procedures by approximately 9 seconds and departure procedures by 1.5 seconds. In critical phases of flight where these procedures are typically flown, this reduction in time could be considered as a large advantage in moving towards chart with fewer paths depicted on the page.

5.3.1. Effect of Chart Manufacturer Type

Two most widely used chart manufacturers, FAA Aeronav Products and Jeppesen, developed the Modified charts in their own standard conventions. Prior to beginning each experiment session, subjects had the option to take the test using Jeppesen or FAA AeroNav Products

charts. All 47 pilots tested in the experiment preferred Jeppesen charts. In order to test FAA developed charts, the experimenters requested 14 volunteered pilots (8 Airline and 6 Corporate) who are Jeppesen chart users to perform information retrieval task using FAA charts. Prior to beginning the task, pilots were given a ten-minute FAA chart refresher course developed by the experimenters (Appendix E). Thus, the results related to FAA chart convention should consider that the pilots are not typical FAA chart users.

Identical information retrieval questions were asked for both FAA and Jeppesen charts. Paired sampled t-tests were conducted between Current and Modified charts to test whether the results are in the same direction for both conventions.

A total of 33 pilots used Jeppesen charts and 14 pilots used FAA charts. As seen from Figure 50 below, pilots had significantly lower response times using Modified charts than Current charts, regardless of chart convention.

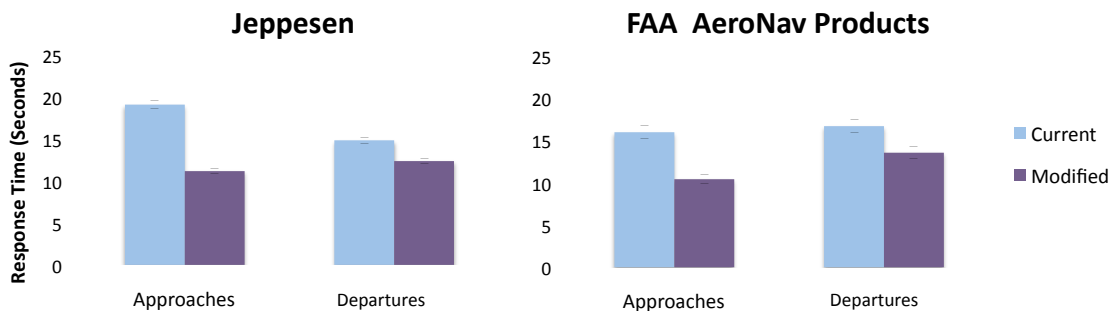

Figure 50. Average response times for Current and Modified charts for each Chart Manufacturer type.

In the Jeppesen chart convention group, for approach procedures, participants performed significantly faster with Modified charts with a mean of 10.4 seconds compared to the Current charts with a mean of 15.9 seconds. For departures, participants had a mean of 13.6 seconds with Modified charts compared to 16.7 for Current charts.

In the FAA chart group, for approach procedures, participants performed significantly faster when using Modified charts with a mean of 11.2 seconds compared to Current charts with a mean of 19.2. Similarly for departures, participants had a significantly lower response time

using Modified charts compared to Current charts. The mean response time for Modified charts was 12.4 seconds while response time for Current charts was 14.9 seconds.

Table 16. Statistics for each Chart Manufacturer type comparing Current and Modified charts.

		Current (Seconds)	Modified (Seconds)	Statistical Testing
FAA	IAP	22.7	13.5	$t(13) = 11.09; p < 0.01$
	SID	11.8	10.3	$t(13) = 2.85; p < 0.01$
Jeppesen	IAP	27.6	14.4	$t(32) = 12.22; p < 0.01$
	SID	14.2	7.3	$t(32) = 6.44; p < 0.01$

Comparison for the response times between FAA and Jeppesen charts was also performed using a One-Way Analysis of Variance (ANOVA) test. The ANOVA tested whether there existed a statistically significant difference between the response times amongst both chart manufacturer (FAA vs. Jeppesen) and chart format (Current vs. Modified). Within the Current chart group, for departures ($F(1,45) = 1.60, p = 0.212$), and for approaches ($F(1,45) = 2.69, p = 0.108$) no statistical significance was found. Similarly within the Modified Chart group, for departures ($F(1,45) = 0.858, p = .359$), and for approaches ($F(1,45) = 0.655, p = 0.422$) also showed no statistically significant effect. Overall, the results concluded that no statistically significant differences for the mean response times existed between the chart conventions.

5.3.2. Effect of Airport

Figure 51 shows the average response times across the airports from which the six procedures were tested in the study. Again, note that the error bars depicted in the figures represent standard error for the response times, which are less than three seconds for all airport types. As seen from the figure, the results are consistent with the overall response times such that pilots performed significantly faster using Modified charts than the Current charts, regardless of procedure.

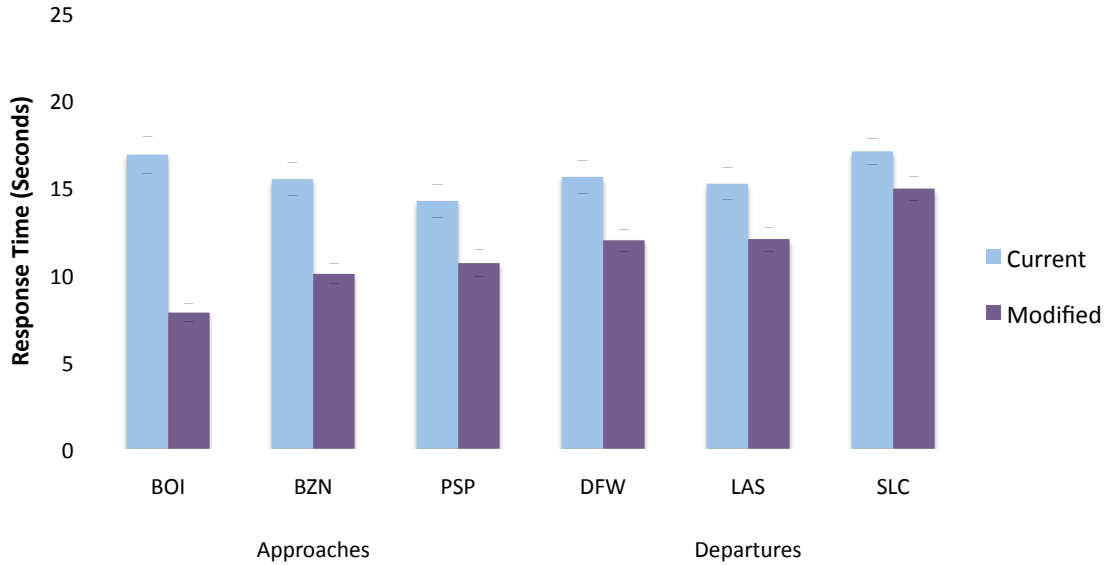

Figure 51. Average response times for Current and Modified charts for each airport tested in the study.

Table 17. Statistics for each airport comparing Current and Modified charts.

Procedure Type	Airport Names	Current (Seconds)	Modified (Seconds)	Statistical Testing
IAP	BOI	16.9	7.8	$t(46) = 19.01, p < 0.001$
	BZN	15.5	10.0	$t(46) = 10.04, p < 0.001$
	PSP	14.2	10.6	$t(46) = 4.81, p < 0.001$
SID	DFW	15.6	11.9	$t(46) = 4.27, p < 0.001$
	LAS	15.2	12.0	$t(46) = 3.78, p < 0.001$
	SLC	17.0	14.9	$t(46) = 3.50, p < 0.001$

Statistical significance of each airport using two tailed paired t-tests of the response times was conducted and the results are shown below in Table 17. All procedures show faster response time using Modified charts than Current charts with p-value less than 0.001. The effect in overall response times was not driven largely by a specific procedure, as all procedures have consistent results. In addition, large reduction in response times is shown for all procedures, minimum being 3.1 seconds for departure procedure at SLC, and maximum being 9.1 seconds for procedure at BOI. Again, this large reduction in information retrieval time can prove to improve overall chart usability and become

beneficial to pilots flying at airports with high levels of terrain like the procedures selected for this study.

5.3.3. Effect of Pilot Type

A further comparison can be made between Current and Modified charts by examining the specific pilot types (i.e., Airline Pilots and Corporate Pilots). Figure 51 below shows the response times for Airline Pilots and Corporate Pilots. As seen from the figure, the trends for the response times both IAPs, as well as SIDs are consistent with the overall trend. Both, Airline and Corporate pilots had significantly lower response times using Modified charts compared to their response times using Current charts. Table 20 shows the specific mean response times and the results from the two-tailed t-tests. As seen from Table 18, the statistical test comparing Modified charts to Current charts for each pilot group yielded p-values less than 0.001.

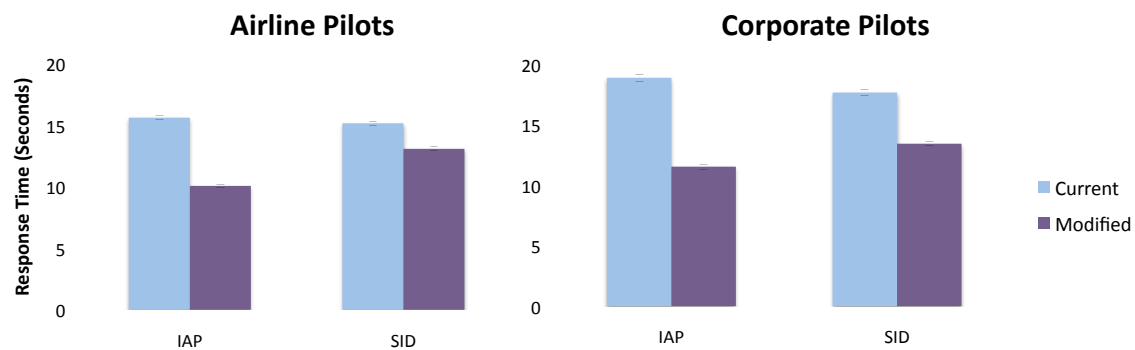

Figure 52. Average response times for Current and Modified charts for each pilot type.

Table 18. Statistics for each Pilot Type comparing Current and Modified charts.

Pilot Type	Procedure Type	Current (Seconds)	Modified (Seconds)	Statistical Testing
Airline	IAP	15.6	10.0	$t(46) = 10.04, p < 0.001$
	SID	15.14	13.1	$t(46) = 4.81, p < 0.001$
Corporate	IAP	18.9	11.5	$t(46) = 3.78, p < 0.001$
	SID	17.7	13.4	$t(46) = 3.50, p < 0.001$

Comparison for the response times between Airline and Corporate pilots was also performed using a one-way ANOVA test. The ANOVA tested whether there existed a statistically significant difference between the response times amongst both pilot type (Airline vs. Corporate) and chart format (Current vs. Modified). There was a statistically significant difference between the response times of Airline and Corporate pilots using Current IAP charts ($F(1,45) = 5.74, p = 0.021$). However, this effect did not exist for SID charts or Modified IAP. For Modified IAP, ($F(1,45) = 1.92, p = 0.175$) no statistically significant effect was found. Within the SID chart group, for Current charts ($F(1,45) = 3.77, p = 0.059$), and for Modified charts ($F(1,45) = 0.103, p = 0.749$) when compared between Airline and Corporate pilots.

5.3.4. Effect of Question Type

As mentioned in Chapter 4, several different types of information retrieval questions were presented to the pilots. All questions were distributed into two main categories: Path-Specific and General. Path-Specific questions pertained to any one path on the chart (e.g., altitude constraints, heading), while General questions pertained to information that was common across all paths (e.g., communication frequencies, airport elevation). Because the number of paths depicted on a chart was reduced for Modified charts, the hypothesis was that information retrieval time to scan for answers to Path-Specific questions would be faster with the modified charts than with the current charts. Likewise, the hypothesis for General questions was that there would be no difference notable in information retrieval time between Modified charts and Current charts. However, certain answers to General questions for approach procedures could also benefit from the chart modifications performed on the planview of the chart. This is further examined in section 5.3.5. Figure 53 below shows the mean response times for both types of questions for each procedure type (i.e., approaches and departures).

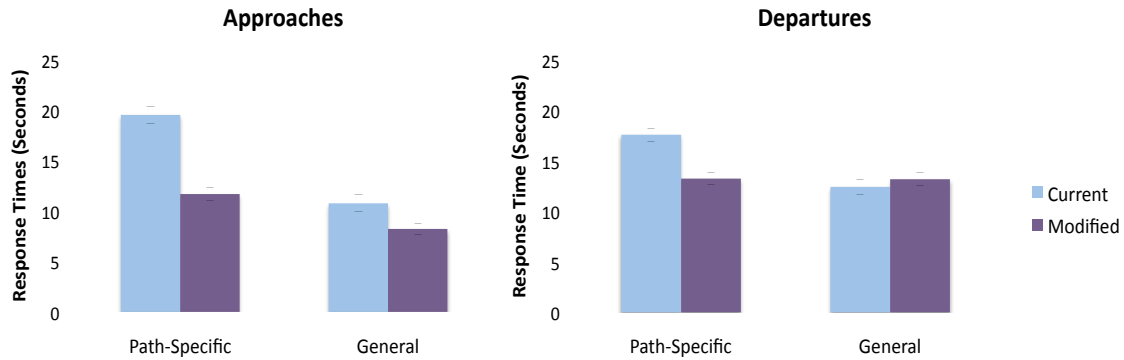

Figure 53. Average response times for Current and Modified charts for each Question type.

For approaches, the response times for Path-Specific questions was significantly faster when using Modified charts, as hypothesized. However, the response times for General questions also showed the same effect (response time for General questions was significantly lower using Modified charts). The response time for Path-Specific questions answered using Current charts have a mean of 11.6 seconds compared to Modified charts which have a mean of 19.5 seconds. The response time for General questions answered using Current charts has a mean of 8.2 seconds compared to Modified charts which has a mean of 10.8 seconds. Results of the two-tailed paired sample t-tests performed are shown in Table 19.

For departures, the response times for Path-Specific questions were significantly faster when using Modified charts compared to Current charts. The response time for Path-Specific questions answered using Current charts have a mean of 17.6 seconds compared to Modified charts which have a mean of 13.3 seconds. However, for General questions, there was no statistically significant difference between Modified chart and Current chart response times. The response time for General questions answered using Current charts has a mean of 13.1 seconds compared to Modified charts which has a mean of 12.4 seconds. Table 19 shows the results of the two-tailed paired sample t-tests.

A further examination of each question type is described further in section 5.3.5 below.

Table 19. Statistics for each Question Type comparing Current and Modified charts.

Procedure Type	Procedure Type	Current (Seconds)	Modified (Seconds)	Statistical Testing
IAP	Path-Specific	19.5	11.6	$t(46) = 15.15, p < 0.001$
	General	10.8	8.2	$t(46) = 6.89, p < 0.001$
SID	Path-Specific	17.6	13.3	$t(46) = 7.48, p < 0.001$
	General	13.1	12.4	$t(46) = 1.09, p = 0.281$

5.3.5 Detailed Evaluation of Question Type Analysis

In this section, different types of Path-Specific and General questions posed to the pilots in the experiment will be examined in depth. As mentioned in Section 4.2, the question types were divided in these categories with the hypothesis that questions that are affected by the chart modifications (i.e., Inside Planview) would have a faster response time when using Modified charts. Likewise, questions that are *not* affected by the chart modifications (i.e., Outside Planview) would not show a difference in the response times when comparing the different chart types (Current vs. Modified).

5.4.1 Path-Specific Questions

As described in Section 4.3.1, five different types of Path-Specific questions were posed in the experiment: distance, track, speed, altitude, and notes. Results for each Path-Specific question are explored below.

5.4.1.1 Approach Procedures

Figure 53 shows the response times for each Path-Specific questions posed in the experiment for RNAV (RNP) IAPs block. On average, pilots answered all path-specific questions significantly faster using Modified charts compared to Current charts. Table 23 below shows the individual means and the two-tailed paired t-test results for each question type. As hypothesized, Path-Specific questions, which are affected by the chart modifications, show a lower response time when using Modified charts.

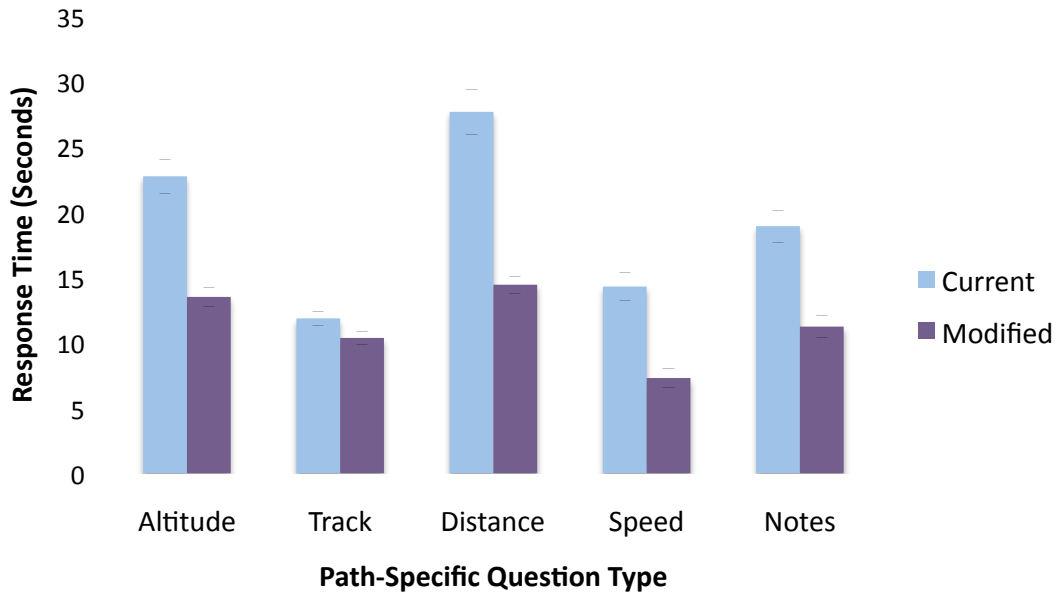

Figure 54. Average response times for each Path-Specific questions for approaches.

Table 20. Statistics for each Path-Specific Question type comparing Current and Modified approach charts.

	Current (Seconds)	Modified (Seconds)	Statistical Testing
Altitude	22.7	13.5	$t(46) = 9.39, p < 0.01$
Track	11.8	10.3	$t(46) = 3.31, p < 0.01$
Distance	27.6	14.4	$t(46) = 8.52, p < 0.01$
Speed	14.2	7.3	$t(46) = 8.82, p < 0.01$
Notes	18.9	11.2	$t(46) = 8.58, p < 0.01$

5.4.1.2 Departure Procedures

Figure 55 depicts the response times for each Path-Specific question posed in the experiment for the departures block. As seen in 5.3.4, pilots answered Path-Specific questions significantly faster using Modified charts compared with Current charts. Looking at specific questions, this trend was notable for questions related to Altitude, Distance, and Notes. However, questions related to “Track” and “Speed” showed no statistically significant difference when compared between Modified and Current chart.

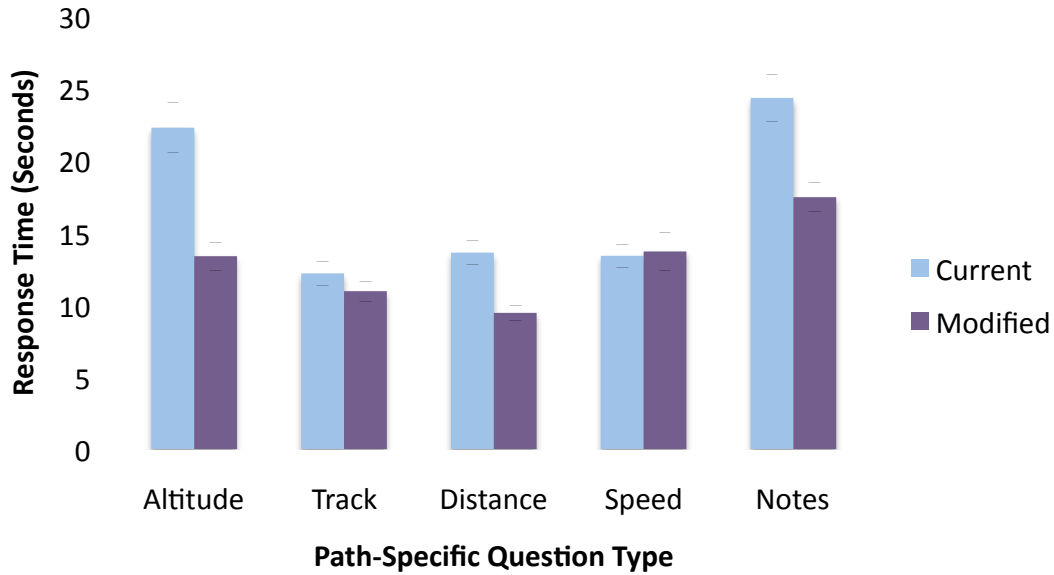

Figure 55. Average response times for each Path-Specific questions for departures.

Table 21. Statistics for each Path-Specific Question type comparing Current and Modified departure charts.

	Current (Seconds)	Modified (Seconds)	Statistical Testing
Altitude	22.2	13.3	$t(46) = 5.21, p < 0.001$
Track	12.1	10.9	$t(46) = 1.50, p = 0.14$
Distance	13.6	9.4	$t(46) = 5.99, p < 0.001$
Speed	13.3	13.7	$t(46) = 0.79, p = 0.43$
Notes	24.2	17.4	$t(46) = 4.95, p < 0.001$

Table 21 above shows the individual means and the results of the two-tailed paired samples t-tests for each question type. As noticed, approximately 4 to 7 seconds of reduction in information retrieval time is noticeable for Path-Specific questions related to Altitude, Distance and Notes. However, this effect is not observable for Track and Speed related questions. This effect was not hypothesized and the reasons are unknown.

5.4.2 General Questions

For approaches in general, answers to all Path-Specific questions can be found inside the planview. However, for General questions, answers to questions can be found inside or outside the planview. Because the paths were removed in the planview for Modified charts,

General questions inside the planview could be affected by the chart modification. Thus, General questions were distributed based on whether the answers to them fell “Inside Planview” or “Outside Planview.”

In this section, Inside Planview and Outside Planview questions within General questions category is explored. As explained before, the hypothesis was that response time for Inside Planview questions would be faster with Modified charts than with Current chart. Likewise, Outside Planview questions would not show a difference in response time when compared between Modified and Current chart.

Figure 56 shows the average response times for Inside Planview and Outside Planview questions. As shown in the figure, if the answers to the questions were Inside Planview, pilots answered General questions faster using Modified charts compared with Current charts. However, no difference was noted between Modified and Current charts when answers to the questions were Outside Planview.

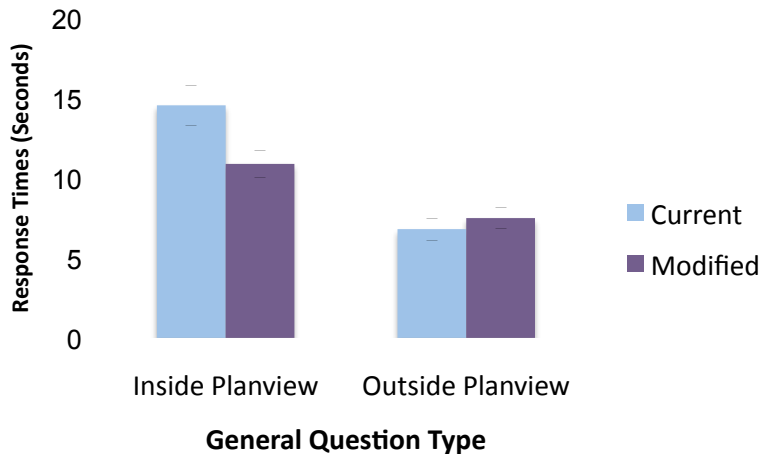

Figure 56. Average response times for each General question type for approaches.

Table 22. Statistics for each General Question type comparing Current and Modified approach charts.

	Current (Seconds)	Modified (Seconds)	Statistical Testing
Inside Planview	14.6	10.9	$t(46) = 3.324, p < 0.01$
Outside Planview	6.8	7.5	$t(46) = 1.524, p = 0.13$

5.5 Subjective Feedback

A post-task questionnaire was presented to pilots after the completion of the information retrieval task. On the questionnaire, pilots had the ability to provide feedback on the experiment and operational feedback regarding their experience using RNAV and RNAV (RNP) procedures.

Fifteen pilots commented on their experience using RNAV and RNAV (RNP) procedures. When asked the question “have you encountered any problems when flying the RNP procedures in your daily operations?” 8 out of the 15 pilot commented on issues with Air Traffic Control authorization. One pilot commented, “ATC is biased to ILS/visual approaches.” Another pilot stated, “ATC does not clear for RNAV and RNAV (RNP) procedures many times.” One pilot also commented that there were a large number of charted altitude restrictions on the SHEAD SEVEN departure from Las Vegas Airport (LAS) (a procedure used in the Experiment) to accommodate ATC.

All pilots agreed that the charts were reasonable and realistic. All pilots also agreed that the experiment display was understandable.

Chapter 6

Summary and Conclusion

6.1. Summary

The FAA and ICAO are transitioning to PBN airspace, in order to increase NAS capacity and efficiency. There are two main types of advanced PBN procedures, RNAV and RNP. RNAV enables aircraft to fly directly from point-to-point on any desired flight path using ground- or spaced-based navigation aids. RNP is RNAV with the addition of onboard monitoring and alerting capability. Both RNAV and RNP procedures allow aircraft to fly accurate routes without relying on ground-based navigation aids. RNAV and RNP procedures facilitate more efficient design of airspace and procedures, offering significant safety improvements and flexibility to negotiate terrain, as well as improving airspace capacity and operational efficiency.

The initial implementation of RNAV and RNAV (RNP) procedures has raised several human factors issues as described in Chapter 1. RNAV Standard Instrument Departures (SID) and Standard Terminal Arrivals (STARs) and RNAV (RNP) Instrument Approach Procedures (IAP) are often more cartographically complex than conventional procedures, with more waypoints, altitude constraints and other variables. In addition, it is common to have multiple RNAV and RNAV (RNP) paths depicted on a single chart, causing increased information density and high levels of visual clutter.

As described in Chapter 2, extensive research has been conducted on the depiction of conventional IAPs. However, limited document research on the depiction of advanced PBN procedures and recent industry committee discussions, have raised concerns that there is high information density and clutter on these charts. Document research by Barhydt et al. (2006) and Butchibabu et al. (2010) has emphasized the need for evaluating the chart design of these procedures contributing to operational safety issues reported in the ASRS

database. Specifically, there is a need to understand what specific procedure variables contribute to the high information density and chart clutter.

Thus, a chart review was conducted on two sets of RNAV and RNP procedures as explained in Chapter 3. One set of “Problematic” RNAV (RNP) IAPs, RNAV SIDs and RNAV STARs were identified based on the operational safety reports obtained through the Aviation Safety Reporting System (ASRS) and documented industry organized forums such as Aeronautical Charting Forum (ACF) and PBN Aviation Rule making Committee (PARC) RNP Chart Saturation Working Group. The second set is identified as the “Baseline” Group, which consists of the top 35 OEP airports that were not included in the ASRS reports or brought to attention in the ACF and PARC meetings by subject matter experts. For the review, an analysis of procedural variables that are depicted on the chart was completed. Both identified sets of charts were reviewed and compared.

A total of sixty-three approach, fifty-two departure, and fifty-four arrival procedures were analyzed. Primary findings from the review concluded that factors associated with high levels of visual clutter included multiple flight paths per page for approach and departure procedures, and complex altitude constraints for arrivals. Multiple waypoints per path was also a factor for both arrivals and approaches. In addition, RF legs were additional factor contributing to visual clutter for approaches.

Multiple flight paths are typically shown on the chart to depict all possible flight paths available to the pilot and ATC. However, once ATC has assigned one specific path to the pilot, all other paths may not be need to be depicted, unless ATC needs to vector the aircraft to another path for traffic separation or weather-related issues. Additionally, previous literature has found that the amount of “irrelevant” information on display increases, visual search time to locate the target information also increases (Baker, 1960).

In addition, in cases where there were multiple paths, particularly multiple IFs, the profile view does not show the complete altitude profile beginning of the IF or IAF. Instead, only the altitude profile for the last, common, segment was shown in the profile view. This was because there was not enough space to show multiple altitude profiles corresponding to the non-common path segments. When there was only one IF or IAF in the procedure, the full altitude profile beginning from that IF was shown in the profile view.

Based on these findings, an experiment was designed to examine the effects of removing paths that are “irrelevant” to the pilot from the chart to simplify the chart. This study evaluated one method to simplify the RNAV (RNP) procedure depiction by reducing the number of paths shown on a single chart page, and adding sufficient chart pages to depict all paths more clearly and with less clutter. An experiment was conducted to evaluate whether these “Modified” charts would impact information retrieval time and accuracy compared with the “Current” charts being used now. A series of Modified charts were designed and prototyped for the experiment. FAA AeroNav Products and Jeppesen created the Modified charts using their own standard conventions. Current FAA AeroNav Products and Jeppesen charts were used as the baseline condition.

Six procedures were selected, including three RNAV departure procedures from Dallas/Fort Worth, Las Vegas, and Salt Lake City airports, and three RNAV (RNP) approach procedures from Boise, Bozeman, and Palm Springs airports. During the experiment, pilots were shown the same procedures in Current and Modified chart format. Details regarding the design of the study are explained in Chapter 4.

Highly visually cluttered RNAV RNP approach and RNAV departure procedures were selected for the study in order to best examine the effect of separating paths across multiple pages. Additional studies may be needed to understand whether this performance benefit remains for less visually cluttered charts. Specifically, a study can be designed to understand how many paths can be depicted on the chart before there is an effect on the information retrieval performance.

Data were collected from 28 commercial airline pilots and 19 corporate pilots with average flight experience of approximately 11,484 hours. Fourteen pilots used FAA AeroNav charts, and 33 pilots used Jeppesen charts.

Overall question response accuracy for all 47 participants was 99.5%. There were no particular differences in accuracy between Modified and Current chart use.

As described in Chapter 5, pilots answered questions significantly faster using Modified charts than Current charts. For approach procedures, the mean response time for Current charts was 16.9 seconds, compared with 10.6 seconds for Modified charts. For departure procedures, the mean response time for Current charts was 16.2 seconds, compared with 13.2 seconds for Modified charts. Response times were also significantly faster for Modified

charts than for Current charts when analyzed for each airport, chart manufacturer (Jeppesen and FAA AeroNav Products), and pilot type (Corporate and Airline).

6.2 Conclusion

The ultimate objective of this study was to improve the usability of complex RNAV and RNP charts to mitigate human factors issues such as increased heads down search time, difficulty in reading critical procedure elements, information interpretation error, and high workload. Increased number of advanced RNAV and RNP procedures will be developed in the future to improve safety, airspace use, and fuel and emission costs. In addition, complex procedures may also contain increased number of paths that can allow aircraft to takeoff and/or land using an optimal route to and from, while negotiating terrain and airspace constraints. As identified by this thesis, increased numbers of paths per procedure results in visually cluttered chart that can cause operational issues. Thus, it is beneficial to consider de-cluttering techniques that could mitigate the operational human factor issues.

The method considered in this study was to depict limited number of paths per page by separating paths across multiple pages. Due to the observable benefit in information retrieval performance, it is evident that this de-clutter technique is an effective method to mitigate clutter and improve chart usability on charts that have increased number of paths. Consequently, this method is not applicable to charts that do not have multiple paths. In addition, simpler and less visually cluttered charts with lower number of paths depicted per procedure may not see the information retrieval performance benefit that is observed in this study with complex charts. A further study may be conducted to determine the number of paths that can be depicted per page before a reduction in information retrieval performance is observed.

Practical applications of the de-cluttering technique should also consider potential drawbacks that can be caused through increase in paper and limited information being shown on the page. Increase in paper may increase time to retrieve the correct chart and cost of production. Limited number of paths depicted on the page may cause pilots to be unaware of other nearby paths that are not depicted but may be available for use.

The study was designed to determine the benefit of one, isolated factor: separating paths across multiple pages to reduce the number of paths shown per page. Thus, the de-cluttering technique used to create the Modified charts was not further optimized by utilizing the additional white space gained from the removal of paths. Example optimization techniques include zooming and re-centering the paths and other procedural information. If such optimization techniques were used, the Modified charts may further improve the information retrieval performance. Practical applications of the de-cluttering technique implemented in the study may use additional optimization techniques to increase chart readability.

Bibliography

- Aeronautical Charting Forum (ACF) (2009). Recommendation Document FAA Control # 09-02-220. Available at <http://aeronav.faa.gov/index.asp?xml=aeronav/acf> (Accessed 16 November 2010).
- Baker, C.A., Morris, D. F., & Steadman, W.C., "Target Recognition in Complex Displays", Human Factors, 1960.
- Barhydt, R. and Adams, C. (2006a) Human Factors Considerations for Area Navigation Departure and Arrival Procedures. Presented at ICAS 2006 – 25th Congress of the International Council of the Aeronautical Sciences, 3-8 Sep. 2006, Hamburg, Germany. Available online at <http://ntrs.nasa.gov/>.
- Baryhdt, R. and Adams, C. (2006b) Human Factors Considerations for Performance-Based Navigation. (NASA/TM-2006-214531). Langley, VA. NASA Langley. Available online at <http://ntrs.nasa.gov/>.
- Blomberg, R., Bishop, E., Hamilton, J. *Evaluation of Prototype Air Carrier Instrument Approach Procedure Charts*. Final Report No. DOT-VNTSC-FAA-95-24.
- Butchibabu, A., Midkiff, A., Kendra, A., Hansman, R.J., & Chandra, D. (2010). Analysis of safety reports involving area navigation and required navigation performance procedures. *Proceedings of the International Conference on Human-Computer Interaction in Aeronautics* (HCI-Aero 2010). 3-5 November, Cape Canaveral, FL.
- Federal Aviation Administration (2010). FAA Needs to Implement More Efficient Performance-Based Navigation Procedures and Clarify The Role of Third Parties. Report Number: AV-2011-025. December 2010.
- Federal Aviation Administration Advisory Circular (AC) 150/15300-13, CHG 6, Appendix 16: New Instrument Approach Procedures, 2000.
- Federal Aviation Administration Advisory Circular 211-2 (1967). Recommended Standards for IFR Aeronautical Charts.
- Federal Aviation Administration (2008) Instrument Flying Handbook. FAA-H-8083-15A. Chapter 8: The National Airspace System. Available Online at http://www.faa.gov/library/manuals/aviation/instrument_flying_handbook/media/FAA-H-8083-15A%20-%20Chapter%2008.pdf.
- Federal Aviation Administration (2008) Instrument Flying Handbook. FAA-H-8083-15A. Chapter 9: The Air Traffic Control System. Available Online at http://www.faa.gov/library/manuals/aviation/instrument_flying_handbook/media/FAA-H-8083-15A%20-%20Chapter%2009.pdf.
- Federal Aviation Administration (2008) Instrument Flying Handbook. FAA-H-8083-15A. Chapter 10: Instrument Procedure Flight Rules (IFR) Flight. Available Online at http://www.faa.gov/library/manuals/aviation/instrument_flying_handbook/media/FAA-H-8083-15A%20-%20Chapter%2010.pdf.
- Federal Aviation Administration (2007) Instrument Procedures Handbook. FAA-H-8261-1A. Chapter 2: Takeoffs and Departures. Available Online at http://www.faa.gov/library/manuals/aviation/instrument_procedures_handbook/media/CH-02.pdf.

- Federal Aviation Administration (2007) Instrument Procedures Handbook. FAA-H-8261-1A. Chapter 4: Arrivals Available Online at http://www.faa.gov/library/manuals/aviation/instrument_procedures_handbook/media/CH-04.pdf.
- Federal Aviation Administration (2007) Instrument Procedures Handbook. FAA-H-8261-1A. Chapter 5: Approach Available Online at http://www.faa.gov/library/manuals/aviation/instrument_procedures_handbook/media/CH-05.pdf.
- Federal Aviation Administration Order 8260.52. United States Standard Required Navigation Performance (RNP) Approach Procedures with Special Aircraft and Aircrew Authorization Required (SAAAR).
- Federal Aviation Administration Order # 8260: Terminal Instrument Procedures (TERPS).
- Federal Aviation Administration Order # 8260-1: Terminal Instrument Procedure (TERPS) Forums Waivers.
- Hansman, R.J. & Mykityshyn, M. (1995) An Exploratory Survey of Information Requirements for Instrument Approach Charts. Final Report No. DOT-VNTSC-FAA-95-6, March 1995.
- Honeywell (2007) RNP SAAAR Economic Benefit Calculator.
- ICAO Doc 8168 Vol II – Procedures for Air Navigation Services: Aircraft Operations (PANSOPS)
- Mangold, S., Eldredge, D., Lauber, E. (1992) Human Factors Design Principles for Instrument Approach Procedure Charts. Volume I – Readability. Final Report No. DOT-VNTSC-FAA-92-9. August 1992.
- MITRE Center for Advanced Aviations Systems Development (2010) Performance Based Navigation Capabilities Report. Available at <http://www.mitreaasd.org/PBNCapabilityReport/>. (Accessed 3 May 2010)
- MITRE Center for Advanced Aviations Systems Development (2011) Performance Based Navigation Capabilities Report. Available at <http://www.mitreaasd.org/PBNCapabilityReport/>. (Accessed 8 Dec 2011)
- Maulter, J., Warner, M., DiSario, R. M., & Huntley, M.S. (1990) Design Considerations for IAP Charts: Approach Charts Track and Communication Frequencies. Report No. DOT/FAA/RD-91/19. VNTSC.
- Mykityshn, M. & Hansman, R.J., (1991) Design and Evaluation of Advanced Electronic Cockpit Displays For Instrument Approach Information. S.M. Thesis, Department of Aeronautics and Astronautics, Massachusetts Institute of Technology. September 1991.
- Ricks, W., Jonsson, J., Barry, J. (1996) Managing Approach Plate Information (MAPLIST): An Information Requirements Analysis of Approach Chart Use. NASA Technical Paper 3561. February 1996.
- Osborne, D.W. & Huntley, M.S. (1992). Design of Instrument Approach Procedure Chart: Comprehension Speed of Missed Approach Instructions Coded in Text or Icons. Report No: DOT/FAA/RD-92/3 VNTSC.

- Osborne, D., Huntley, S., Turner, J., Donovan, C. (1995) The Effect of Instrument Approach Procedure Chart Design on Pilot Search Speed and Response Accuracy: Flight Test Results. Final Report No. DOT-VNTSC-FAA-95-13. June, 1995.
- PARC RNP Charting WG (2009) RNP Chart Saturation and Volume for newly published RNP SAAAR Procedures. August 2009
- PARC RNP Charting WG (2010) Recommendations on RNP SAAAR Instrument Approach Procedure (IAP) Chart Clutter.
- Professional Pilot. Performance-Based Navigation – A Combination of RNAV and RNP (Accessed January 2010).
- Recommendations on RNP SAAAR Instrument Approach Procedure (IAP) Chart Clutter from PARC RNP Charting WG. 12 March 2010.
- Teichner, W.H., & Mocharmuk, J. B. (1979) Visual search for complex targets. Human Factors, 21, 259-275.

Analysis of Safety Reports Involving Area Navigation and Required Navigation Performance Procedures

Abhizna Butchibabu¹, Alan Midkiff¹, Andrew Kendra², R. John Hansman¹, Divya C. Chandra²

¹Massachusetts Institute of Technology
77 Massachusetts Avenue, Cambridge, MA USA
{abhizna, rjhans}@mit.edu, ahmidkiff@aol.com

²United States Department of Transportation
Volpe National Transportation Systems Center
55 Broadway, Cambridge, MA 02142, USA
{Andrew.Kendra, Divya.Chandra}@dot.gov

ABSTRACT

In order to achieve potential operational and safety benefits enabled by Area Navigation (RNAV) and Required Navigation Performance (RNP) procedures it is important to monitor emerging issues in their initial implementation. Reports from the Aviation Safety Reporting System (ASRS) were reviewed to identify operational issues related to RNAV and RNP procedures. This review is part of a broader effort to understand emerging human factors issues for performance based navigation. A total of 285 relevant reports filed between January 2004 and April 2009 were identified and analyzed. For departure procedures, the majority of reports mention heading or track deviations, which are classified as “lateral” issues. For arrival and approach procedures, the majority of reports mention altitude deviations, which are classified as “vertical” issues. The track and heading issues were often associated with dropped transition waypoints in the Flight Management System (FMS). Altitude deviations during arrival and approach procedures were mainly associated with Air Traffic Control (ATC) “descend via” phraseology. The analysis shows that RNAV and RNP procedure issues are integrated with ATC operations, FMS, and procedure design issues.

Keywords

Aviation Safety Reporting System, ASRS, RNAV, RNP, SIDs, STARs, IAPs, Performance Based Navigation, PBN

INTRODUCTION AND MOTIVATION

The Federal Aviation Administration (FAA) and International Civil Aviation Organization (ICAO) are transitioning to performance based navigation airspace. As a result, more Area Navigation (RNAV) and Required Navigation Performance (RNP) procedures are being developed (MITRE CAASD, 2010). RNAV procedures allow the aircraft to fly directly between points in space without relying on ground-based navigation aids. RNP procedures meet specific requirements for position determination and track conformance, allowing the aircraft to fly more precise paths. RNAV and RNP procedures offer operators new levels of flexibility to negotiate terrain, airspace, and environmental considerations, and offer significant safety improvements. Operators see these benefits, and are pushing to develop more of these procedures.

However, there are human factors concerns because RNAV and RNP procedures can result in paths that are complex to fly and typically require the assistance of a Flight Management Computer (FMC) to negotiate precise speed, altitude, and lateral path constraints. A list of related human factors issues was collected and summarized by Barhydt and Adams in a comprehensive research report (2006a). Separately, Barhydt and Adams (2006b) reported on an exploratory study using the Aviation Safety Reporting System (ASRS) database to identify 124 reports filed between 2000 and mid-2005 related to RNAV and RNP departure and arrival procedures at seven specific airports.

Barhydt and Adams were the first research team to systematically examine human factors issues related to RNAV RNP procedures. They broadly categorized key issues as being related to air traffic operations, pilot interpretation of procedures, and procedure design challenges with aircraft automation and charting. The research presented in this paper is part of a larger effort to build upon the work of Barhydt and Adams to understand emerging human factors issues with RNAV and RNP procedures related to procedure design and to understand charting issues for RNAV/RNP procedures in particular.

The goal of this review of events from the ASRS database is twofold. First, we are interested in knowing what performance issues related to procedure design and charting have been documented. Second we are interested in updating the analysis done by Barhydt and Adams by reviewing more current events and documenting human-performance issues.

AVIATION SAFETY REPORTING SYSTEM (ASRS) BACKGROUND

Safety reports of interest were identified from the public Aviation Safety Reporting System (ASRS) database managed by the National Aeronautics and Space Administration (NASA). The database contains voluntary self-reported descriptions of aviation safety events and can be searched in a flexible, customizable way. The outcomes and anomalies found in the ASRS reports are typically an actual violation or a “near violation” (i.e., a violation that almost occurred) of a requirement (e.g., an altitude clearance, or published heading for a departure or arrival procedure). Filing a voluntary ASRS

report grants the reporter a level of immunity for the violation as detailed in AC 00-46D (FAA, 1997).

There are limitations to the data contained in ASRS reports, which are described online (<http://asrs.arc.nasa.gov/>). The public database contains only a subset of the reports submitted for processing, so the frequency of events does not represent the total population of events. Because of the self-reporting nature of ASRS, reports may contain subjective biases. Reporters include air traffic controllers, pilots, and other crewmembers.

METHOD

The following fields were specified in order to identify relevant reports: Date of Incident, Keyword, Event Anomaly, and Flight Phase. The criteria used for these fields are listed in Table 1 below. A total of 2104 reports were extracted based on these search criteria. However, this set contained numerous cases that did not involve RNAV/RNP procedures because of the way the search query was constructed; these cases were discarded manually, yielding a total of 285 relevant reports for analysis.

The final set of relevant ASRS reports was reviewed to identify human factors issues related to RNAV procedures. The reports were grouped based on the type of procedure involved for the analysis: Standard Instrument Departure (SID), Standard Terminal Arrival (STAR), and Instrument Approach Procedure (IAP). The subjective narrative was reviewed carefully in order to extract as much information as possible about the event.

Field	Filter Criteria
Date of Incident	Jan 2004 – Jan 2010
Keyword	RNAV, RNP, Chart, Approach, SID, STAR, DP, IAF, FAF
Event Anomaly	Airspace Violation, ATC issues, Conflict (airborne, NMAC), Deviation – Altitude, Deviation – Procedural, Deviation – Speed, Deviation – Track/Heading
Flight Phase	Takeoff, Initial climb, Climb, Descent, Initial Approach, Final Approach, Landing

Table 1. Criteria used to search the ASRS database.

Each ASRS report was reviewed independently by two researchers. The reviewers determined whether the flight deviation that occurred was in the Lateral, Vertical, or Speed domain(s). Lateral issues included deviations in track or heading. Vertical issues pertain to altitude deviations. Speed deviations are less common than altitude deviations because speed is typically only a constraint below 10,000 ft altitude. Reviewers could assign more than one domain to a given report if multiple deviations occurred.

The reviewers also iteratively created a list of recurring problems that contributed to the event. The first iteration of the list of issues included the four broad categories that were used by Barhydt and Adams (2006b): automation, air traffic control, airline operations, and procedure design. However, this categorization proved to be too general given the large number of cases in the data set (285). Therefore, more specific issues categories were constructed. For example, procedure design issues were subcategorized based on their relation to:

- Chart Format (e.g., single page, fold-out, multiple pages)
- Chart Density (large amount of information on the chart in a small space)
- Graphic (visual depiction of the procedure)
- Notes (confusion with text description or procedure notes)
- Complexity (difficult to fly, e.g., hard bank angles required)
- Waypoint Constraints (depiction of altitude and other constraints at the waypoint)
- Other (miscellaneous chart confusion, unable to categorize)

To complete the analysis, ratings between researchers were reconciled and recurring problems were tallied.

RESULTS AND DISCUSSION

Of the 285 reports identified in this review, 202 pertain to departures, 69 pertain to arrivals, and 14 pertain to instrument approaches. The bulk of reports (235, or 82%) were from Title 14 Code of Federal Regulations (CFR) Part 121 operators (scheduled airline carriers). Just two reports were from Title 14 CFR Part 135 (charter/air taxi) operators and 45 were from Title 14 CFR Part 91 (private) operators. Although we requested reports through 2010, the most recent event retrieved was from April 2009, likely because of the delay in processing reports for the public database.

A large number of the reports in our set (41%) were filed in 2006. This was, coincidentally, the same year that ASRS published its own brief analysis of the Dallas-Fort Worth RNAV departure procedures (NASA, 2006). Many of the reports in our data set (88) are from the Dallas-Fort Worth region as well. This pattern may mean that: (a) Dallas-Fort Worth is an especially problematic region, (b) the ASRS team may have preferentially processed reports of RNAV procedure issues from Dallas-Fort Worth in 2006, or, (c) both.

Overall Results

Figure 1 below shows the number of reports classified in terms of the flight deviation domain, by type of procedure. Of the 202 departure-related reports, 175 involved lateral deviations (87%). For arrival procedures and approach procedures, deviations in the vertical domain were more frequent. Thirty reports out of the 69 arrivals (43%) and 12 out of 14 (86%) approach procedure deviations were in the vertical domain. (Note that because a single event could be assigned multiple domains, the sum of cases shown in Figure 1 is greater than the total number of cases.)

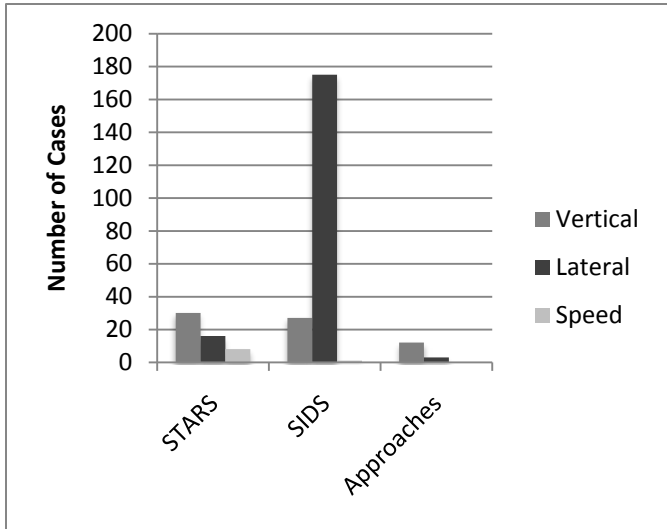

Figure 1. Deviations reported for each type of procedure categorized by Vertical, Lateral and Speed domain.

Figure 2 shows the number of cases for each chart and procedure design issue subcategory, as described earlier. A total of 59 cases of procedure design issues were identified. A single ASRS report could have generated more than one of these issues.

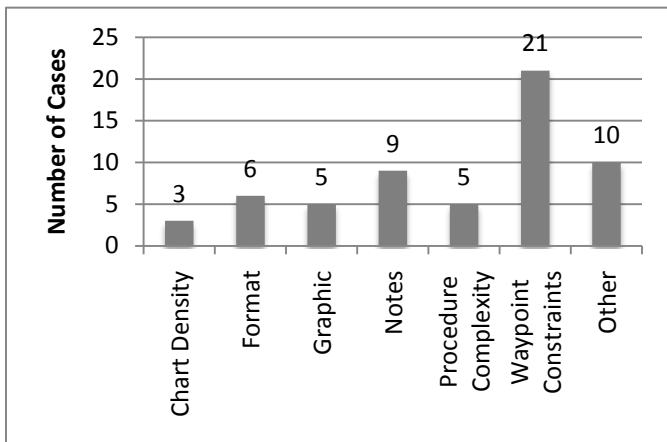

Figure 2. Frequency of procedure design issues across departures, arrivals, and approaches.

Waypoint Constraints were the most common problem across all procedures (21 reports). Examples include (a) confusion about the waypoint constraint and (b) not being able to conform to the depicted altitude or speed restriction. The second most common problem was with notes depicted in the procedure. In many of these cases, pilots reported being confused by the text descriptions of procedures that accompany the visual depiction. In six cases pilots reported issues with multi-page or fold-out chart formats. Less frequently observed issues related to procedure design include chart density, graphic depiction in charts, and procedure complexity.

Departure Procedure Issues

As mentioned earlier, the most frequent issue with departures was related to flight track/heading, that is, the lateral domain.

Figure 3 shows a histogram of departure procedures issues. Four issues were categorized: *ATC Direct To and Resume*, *Climb Direct*, *Dropped Transition Waypoints*, and *Chart & Procedure Design*. A significant number of incidents related to departure procedures were reported by S80 crews, perhaps due to the high percentage of S80 operations out of Dallas-Fort Worth.

The most common issue was *Dropped Transition Waypoints* (30%). This refers to the fact that waypoints were sometimes dropped from the flight path in the Flight Management System (FMS) for unknown reasons. This issue was mentioned in the NASA Callback newsletter (NASA, 2006). The suggested solution was for pilots to check and recheck that all transition waypoints are in the system, especially if Air Traffic Control (ATC) changes a clearance.

Dropped Transition Waypoints may occur in combination with a change in the ATC clearance, such as the *Direct to and Resume*, a last minute change of departure runway, or a *Climb Direct* after departure. These clearances usually result in an off-path vector by ATC during climb out, with a subsequent resumption of the SID from a downstream waypoint. This problem was observed in 24 reports (11%).

During pre-flight, flight crews follow strict procedures in a relatively undistracted environment to check and recheck SID waypoints and waypoint constraints to ensure they match the chart. This task may not be easy if the chart has high information density or clutter. When the programmed route has to be modified in the high-workload dynamic environment present in the terminal area climb out, additional tasks including flying the aircraft, monitoring ATC and traffic, deciphering detailed charts, and other distractions can preclude a thorough recheck of the procedure. In particular the recheck of downstream waypoint constraints may be "hidden" in a subsequent Control Display Unit (CDU) page.

ATC may issue off-path vectoring for the purpose of shortening the path, separating traffic, or some other anticipated benefit. This however, must be balanced against the workload spike associated with in-flight FMS route modifications during dynamic phases of flight, which results in a higher risk of dropping waypoints and other errors. It may be worth investigating the human factors issues and cost/benefit tradeoffs of always requiring the procedures to be "flown as depicted", or evaluating whether procedure/depiction modification would facilitate re-acquisition of the programmed route at *downstream* waypoints, while minimizing trajectory errors.

Chart & Procedure Design issues, which were discussed earlier in the context of all procedures, are also shown in Figure 3 for departure procedures only. Approximately half of the overall *Chart & Procedure Design* issues occurred in departure procedures.

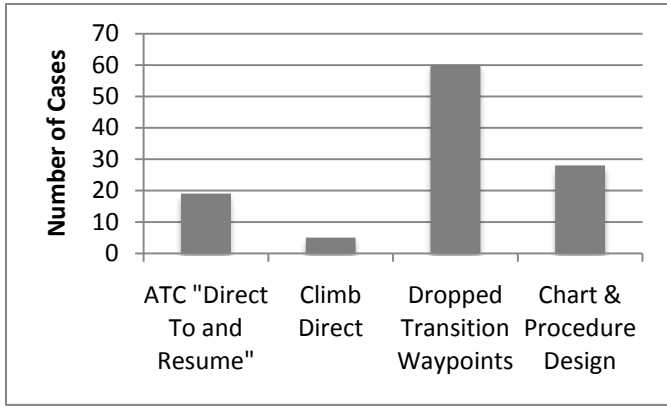

Figure 3. Departure procedure issues

Arrival Procedure Issues

As mentioned earlier, the most common problems with arrivals are related to altitude, that is, the vertical domain. Figure 4 shows a histogram of arrival procedure issues: *ATC "Descend Via" Clearance, Clearance Amendments & NOTAMS, and Chart & Procedure Design.*

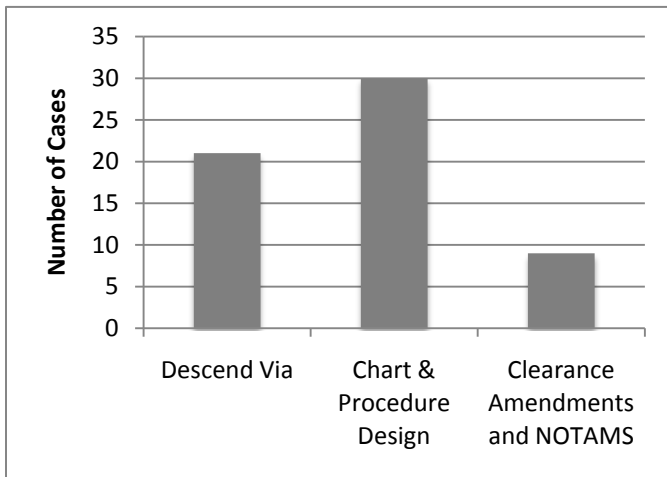

Figure 4. Arrival procedure issues

The most common issue was *Chart & Procedure Design* (43%). This issue was discussed in detail in the previous section. Approximately 50% of reports related to *Chart & Procedure Design* were reported for arrival procedures.

The second most common issue was *ATC "Descend Via" Clearances* (30%). This usually resulted in a pilot deviation for missed crossing restrictions when using ATC phraseology to "descend via" a procedure.

Pilots were confused by the "descend via" phraseology in several reports. As one pilot wrote:

"In talking with many other plts about RNAV ARR/DEP procedures it has become clr to me that there is a lot of confusion in general as to what is expected of flt crews. It seems the more I talk to people who have been airline plts a lot longer than me, I become even more confused with the subject. I keep getting 20 different answers from other plts and ctlrs and plts who have talked to ctlrs. I feel FAA should

really provide some guidance and take away the ambiguity from procs" (ACN 783805, 2008).

Another set of issues are *Clearance Amendments & NOTAMS* where modifications are made to the published procedure by the use of Notice To Airmen (NOTAM) or via ATC vectoring. A clearance amendment given mid-flight (in many cases) has caused pilot distraction or pilot confusion and increased procedural complexity. For example, one pilot reported that:

"the NOTAM changes many of the crossing restrs, and it is typical to get a dsnd via clrcn on this arr. I then read the changes to the capt and he entered them into the FMS. This distracted the capt from entering the new alt into the alt alerter, and me from verifying it... A few minutes I looked up at the mfd and realized we were....and still at FL220. I informed capt, he said he was unaware of receiving the crossing restr. We queried ATC, and were vectored of the arr and given a descent" (ACN 803827 2008).

Approach Procedure Issues

Of the 285 reports in our data set, only 14 pertained to approaches. Twelve of these 14 indicated vertical deviations (85%). Seven of the 14 had a deviation in altitude at the final approach fix. Twelve of the 14 reports were from Part 91 operators. There were no particular identifiable trends among these 14 reports. The reason that so few approaches were identified in this data set may be because RNP approaches are typically specially authorized for particular aircraft and require aircrew training. These are relatively new procedures that receive limited usage by just a few airline operators.

SUMMARY AND CONCLUSIONS

New RNAV and RNP procedures are being developed and integrated into operations at a rapid pace. These new procedures create both opportunity and challenges. The introduction of these complex procedures has resulted in the emergence of several human factor issues.

Two key issues documented in the ASRS database are: (a) for departure procedures, deviations in the lateral domain such as dropped transition waypoints in the FMS and ATC off-path vectoring, (b) for arrival procedures, deviations in the vertical domain where altitude restrictions were not met due to confusion with "descend via" clearances given by ATC and amendments creating modifications to the already complex procedures. Data on approach procedures was too limited to make any strong conclusions.

Although the issues found in this analysis are not all specifically related to RNAV, they are exacerbated by the increasing implementation of RNAV procedures. Going forward, more complex procedures will be developed and resolutions for these issues should be identified for future implementations. The analysis revealed that the reported problems were a combination of pilot, ATC, aircraft automation, and procedure design. Thus, an integrated solution will be required.

ACKNOWLEDGMENTS

This paper was prepared by MIT and the Behavioral Safety Research and Development Division at the Volpe National Transportation Systems Center (Volpe Center). MIT was

funded by the Volpe Center (Contract No. DTR57-07-D-30006). The Volpe Center was funded by the FAA Human Factors Research and Engineering Group (AJP-61) in support of Aviation Safety (AVS). We thank the FAA program manager Tom McCloy and FAA technical sponsor Kathy Abbott for their assistance.

The views expressed herein are those of the authors and do not necessarily reflect the views of the Volpe National Transportation Systems Center, the Research and Innovative Technology Administration, or the United States Department of Transportation.

REFERENCES

1. Barhydt, R. and Adams, C. (2006a) *Human Factors Considerations for Area Navigation Departure and Arrival Procedures*. Presented at ICAS 2006 - 25th Congress of the International Council of the Aeronautical Sciences, 3-8 Sep. 2006, Hamburg, Germany. Available online at <http://ntrs.nasa.gov/>.
2. Barhydt, R. and Adams, C. (2006b) *Human Factors Considerations for Performance-Based Navigation*. (NASA/TM-2006-214531). Langley, VA. NASA Langley. Available online at <http://ntrs.nasa.gov/>.
3. Federal Aviation Administration, Advisory Circular (AC) 00-46D, February 26, 1997. Aviation Safety Reporting Program.
4. National Aeronautics and Space Administration (NASA) Aviation Safety Reporting System Callback newsletter, No. 316, February 2006. Heads Up! — DFW RNAV Departure. Available online at <http://asrs.arc.nasa.gov/publications/callback.html> (Accessed 3 May 2010)
5. MITRE Center for Advanced Aviations Systems Development (2010) *Performance Based Navigation Capabilities Report*. Available at <http://www.mitreaasd.org/PBNCapabilityReport/>. (Accessed 3 May 2010)

Appendix B1: Aeronautical Charting Forum Issue Paper # 10-01-294

AERONAUTICAL CHARTING FORUM Instrument Procedures Group April 27, 2010

History Record

FAA Control # 10-01-294

Subject: RNP SAAAR Intermediate Segment Length and ATC Intervention

Background/Discussion: ATC is increasing the use of direct-to-the-IF to either *expedite* the IAP, or because of *intervention* for spacing, sequencing, etc. The limit imposed on ATC is a 90 degree course change at the IF, thus the presumption for procedure design purposes is a 90-degree course change fly-by at the IF. In most RNAV IAPs, the width and the length of the intermediate segment is sufficient to accommodate a 90-degree course change fly-by of the IF (DTA and recovery to centerline). But, where there is one, or more intermediate segment step-down fixes then the distance between the IF and the first segment step-down may be insufficient to accommodate DTA and recovery to centerline.

Much more significant, though, is the issue of the intermediate segment length and width in RNP SAAAR IAPs. The RNP SAAAR criteria specify a standard intermediate segment with of 2 miles, centerline to edge (2 X 1.0 RNP), and a minimum segment length predicated only on the magnitude of course change (if any) at the IF. This is the pertinent criterion from FAAO 8260.52:

RNP SEGMENT LENGTH. Design segments with sufficient length to accommodate the required descent as close to the OPTIMUM gradient as possible and DTA (see paragraph 1.13) where turns are required. Minimum straight segment (any segment) length is 2xRNP (+DTA as appropriate for fly-by turn constructions). Paragraph 2.8 applies where RNP changes occur (RNP value changes 1 RNP prior to fix). The maximum initial segment length (total of all sub segments) is 50 NM.

If there is no course change at the RNP SAAAR IF the intermediate segment minimum length could be very short, and not nearly able to accommodate an ATC-imposed significant course change at the IF. Further, where obstacles or other critical conditions dictate, the RNP SAAAR intermediate segment width could be as little as 2 X 0.10 RNP (2/10 of 1 nautical mile). (Ref: FAAO 8260.52, Table 1-1)

This issue was presented to the PARC by NBAA and supported by the RNP SAAAR charting working group. The PARC steering committee subsequently supported the issue and requested that NBAA bring it before the ACF-IPG as the proper medium for discussion and resolution of the criteria issues.

Finally, the ACF-IPG has determined in Issue 96-01-166, "Determining Descent Point of Fly-by Waypoints" that descent at the bisector of the fly-by is acceptable. Because of the constraints of RNP containment area widths, descent at the bi-sector is *not* acceptable in RNP SAAAR IAPs except where designed into the procedure; i.e., course change at charted TF-to-TF segments.

Recommendations: The length of the RNP SAAAR intermediate segment must be sufficient to accommodate a “worst case” ATC-directed course change of 90 degrees, which length must include DTA for a 90-degree course change, recovery of Performance Based Navigation (PNB) and recovery of the vertical profile and stabilized flight prior to the final approach segment. Because ATO is currently proposing to provide direct-to-the-IF clearances in both radar and non-radar environments, the design criteria presumption must be a non-radar environment.

Where an RNP SAAAR IAP has multiple intermediate segments, one of these intermediate segments must be a TF leg aligned with the final approach segment (or at least the first portion of the final approach segment) and must be of sufficient length to accommodate the issue set forth in this issue paper. The other intermediate segments in a multiple intermediate segment RNP SAAAR IAP may be of any length; however, ATC needs to be and trained to provide direct-to clearances only to the straight segment IF.

Order 8260.52 criteria needs to be changed to provide criteria to resolve the issue presented in this issue paper. ATO needs to provide training to controllers on which IF is the appropriate IF for direct-to clearances in multiple intermediate segment RNP SAAAR IAPs.

Further, Order 8260.54A criteria needs to be reviewed to determine whether intermediate segment criteria is sufficient to accommodate ATC-directed 90-degree course changes at the IF, particularly where the procedure itself does not have 90-degree course changes at the IF designed into an RNAV IAP. Distance to intermediate segment step-down fixes must also be considered in RNAV IAP design criteria.

Comments: This issue affects FAA Orders 8260.52 and 8260.54A. It also affects present and pending ATC directive material for direct-to-the IF clearances.

Submitted by: Richard J. Boll II

Organization: NBAA

Phone: 316-655-8856

FAX:

E-mail: richard.boll@sbcglobal.net

Date: April 2, 2010

Initial Discussion - Meeting 10-01: New issue introduced by Rich Boll, on behalf of NBAA. ATC is increasing the use of direct-to-the-IF clearances to either expedite the approach or because of ATC required intervention due to traffic sequencing. Current guidance allows up to a 90 degree intercept at the IF for RNAV IAPs. However, NBAA is concerned that applying the 90 degree intercept on RNP SAAAR may compromise obstruction clearance and flyability for RNP approaches with shortened intermediate segments and reduced procedure design widths for obstacle containment. This issue was previously presented to the PARC by NBAA and is supported by the PARC RNP SAAAR charting working group. The PARC steering committee subsequently supported the issue and requested that NBAA bring it before the ACF-IPG as the proper medium for discussion and resolution of the criteria issues. NBAA is recommending that criteria in Orders 8260.52 and 8260.54A be reviewed to ascertain whether intermediate segment length requirements are sufficient for ATC directed 90 degree direct-to clearances. Tom Schneider, AFS-420, briefed the

following update as received from Jack Corman, AFS-420's lead RNAV criteria specialist, who performed a preliminary review of the issue : "Unless the entire Intermediate Segment altitude is at or above the MVA, we cannot guarantee obstacle protection for turns in excess of approximately 60 degrees unless the evaluation area is expanded. Work has started on determining the magnitude of expansion required. When draft criteria is written, it will enter the US-IFPP approach working group coordination process. Expect signed revised criteria in 60-90 days if standard coordination is required." Brad Rush, AJW-372, showed several examples of approaches where allowance for a 90 degree turn at the IF will require increased intermediate segment lengths. Tom stated the issue would be forwarded to the US-IFPP for consideration. **ACTION: AFS-420 (US-IFPP)**

Meeting 10-02: Tom Schneider, AFS-420, briefed the following from Jack Corman, the AFS-420 TERPS RNAV criteria specialist:

"The October 2, 2009 memorandum on RNAV segment length identifies design length limitations in Order 8260.54A. Order 8260.52 contains RNP SAAAR segment length limitations. Both Orders are subject to the "up to 90 degree intercept clearance" authority assumed in 7110.65. However, the Order 7110.65 ATC allowance of clearance direct to join an RNAV approach procedure at fixes following the IAF at intercept angles up to 90 degrees may result in a turn that the designed segment length was not intended to accommodate. In these instances, air traffic will assure obstacle clearance is not compromised through use of radar and other mechanisms. AFS-420 discussed this with ATC at length and they satisfied our concerns when the segment RNP value was 1.0 or greater. If < 1.0, amendment action or statement of ATC accepting obstacle clearance responsibility is required.

The AFS concerns were centered on 2 problems: 1) Inadequate segment length to accommodate the turn, and 2) Descent into unevaluated airspace.

1. Radar monitoring is required. Controllers are trained to take action when they observe gross deviations from prescribed paths. This training and expected reaction is inherent to the radar controller discipline. The controller would intervene to maintain altitudes at or above MVA and provide vectors back toward the course or re-sequence the aircraft. Although Flight Standards may and does provide input, controller responsibilities and the ATC discipline is under the purview of the ATO through Order 7110.65. All changes go through a SMS process with Flight Standards representation to assure safety

2. These are direct clearance to the IF or fixes between the IF and PFAF. The segment width is +/- 2 NM. Turn radius should be in the vicinity of 2.5 to 3.5 NM (example airport at 4000, aircraft at 6000). At a 90 degree turn, the DTA is equal to turn radius. If descent commences at the bisector, and the turn radius was as large as 4 miles, descent out of the intermediate minimum altitude would occur at or just slightly before crossing the segment boundary. The MVA ROC is 1000, intermediate segment ROC is 500. If the area was expanded to evaluate the turn, at least 500 feet ROC would exist. The probability of obstacle conflict is very, very low.

For RNP values <1.0, segment half width would decrease, but the DTA stays the same. We are not yet comfortable with allowing the operation with less than a 2 NM half-width without expanding the OEA and evaluating the area."

Gary Fiske, AJT-28, stated that ATC will radar monitor all "direct to" clearances; however, they do not care what RNP value is designed in the procedure. The MVA altitude at the IF where the turn commences provides 1,000 feet of ROC, twice the intermediate segment requirement of 500 feet. Tom stated this represents a disagreement between ATC and AFS that the US-IFPP must address. **ACTION: AFS-420 (US-IFPP)**

Meeting 11-01: Tom Schneider, AFS-420, briefed the following update as received from Jack Corman, the AFS-420 lead RNAV criteria writer: The following is the US-IFPP's latest proposal, but no one has authorized us to go forward and issue a NOTICE detailing the evaluation. "Where (if) ATC assumes obstacle clearance responsibility with radar monitoring until the aircraft is established on the inbound course, there is no objection. Without ATC accepting obstacle clearance responsibility until the aircraft is established on course, RNP values <1.0 must be successfully evaluated prior to "direct-to" clearance application." Tom noted that at the last meeting the Terminal Service Unit representative (Gary Fiske, AJT-28) stated that "ATC will radar monitor all "direct to" clearances; however, they do not care what RNP value is designed in the procedure. He asserted that the MVA altitude at the IF where the turn commences provides 1,000 feet of ROC, twice the intermediate segment requirement of 500 feet." This represents a disagreement between ATC and AFS that the US-IFPP must address. The Executive Director of the US-IFPP will keep the ACF-IPG apprised of the issue status. **ACTION: AFS-420 (US-IFPP)**

Meeting 11-02: Tom Schneider, AFS-420, briefed the following update as received from John Bordy, AFS-420 (ISI), the specialist assisting in addressing the ATC response as endorsed by Jack Corman, the AFS-420 lead RNAV criteria writer: "The latest iteration of the draft Document Change Proposal (DCP) to Order 7110.65, paragraph 4-8-1 requires ATC to radar monitor any "direct-to" application associated with a clearance for an RNAV (RNP) approach. This requirement will be valid for all RNAV (RNP) approaches, without regard to the RNP value of the segment associated with the fix used for the "direct-to" clearance. AFS-420 is satisfied with the language of the DCP and recommends closure of this item". Terry Pearsall, AJT-28 briefed that the Safety Risk Management Decision (SRMD) was uncontested. The group consensus was to leave the issue open until the change is published in JO 7110.65. AJT-24 will track the DCP change until published. **ACTION: AJT-24.**

Appendix B2: PARC RNP Charting WG Recommendations

PARC RNP Charting WG

Recommendations on RNP SAAAR Instrument Approach Procedure (IAP) Chart Clutter

Introduction

The PARC RNP Charting WG was tasked to review RNP SAAAR charts and provide a set of recommendations that if implemented, should result in uncluttered and operationally usable charts. This tasking was generated as a result of user complaints about the clutter and difficulty in reading RNP SAAAR charts for Boise (BOI) and Raleigh-Durham (RDU). See appendix for examples.

Scope

The WG recommendations apply to fixed wing RNP SAAAR IAP charting. Helicopter charts were not addressed and no recommendations are made for helicopter charting. SID and STAR charting was not evaluated. Procedure design criteria in FAA Order 8260.52 and AC 90-101 requirements were deemed out-of-scope. Information contained in FAA Order 7110.65 and individual charting manufacturers' specifications were also considered out-of-scope.

Overview

The working group determined that inappropriate implementation of criteria can result in chart clutter and other unintended consequences. The group did not identify a deficiency in the 8260.52 criteria that needed addressing to resolve chart clutter issues. The recommendations in this document, if implemented, are intended to reduce chart clutter. Stakeholders involved in the procedure design process e.g. air traffic, lead operators, and procedure design specialists should be aware of the recommendations contained in this document. During discussion issues were identified that were out-of-scope that the group believes need addressing for a successful implementation of RNP SAAAR operations. These issues are documented in the Annex to this paper.

Recommendations

1. Additional Human Factors research required. The group recognized during the deliberations that there was limited research data on how, when, and why pilots use various elements on a chart, particularly when some of those elements are also available on a Navigation Display (Moving Map) or on the Flight Management System (FMS) display. The consensus was that further research was required and it was agreed that one of the principle recommendations should be that the PARC should encourage the FAA to fund and support Volpe human factors research in this area.
2. Charting implications should be considered during procedure design. Procedure designers should consider chart clutter implications at an early stage during the procedure design process. One means of achieving this objective is to use the recommendations in this paper, in conjunction with the use of advanced procedure graphics.

3. Procedures should be able to be depicted uncluttered on a standard size U.S. government chart. Charts larger than the standard U.S. government charts are not to be required or assumed by the procedure designer as a means of alleviating chart clutter.

NOTE: Chart producers retain the option of using larger charts or split charts (where the procedure depiction is broken into two or more pages) when desired.

4. Procedures that split into two separate paths that rejoin at a downstream point shall not be developed. An example of this type of procedure is provided below.

NOTE: This issue pertains more to procedure design and implementation than to chart clutter.

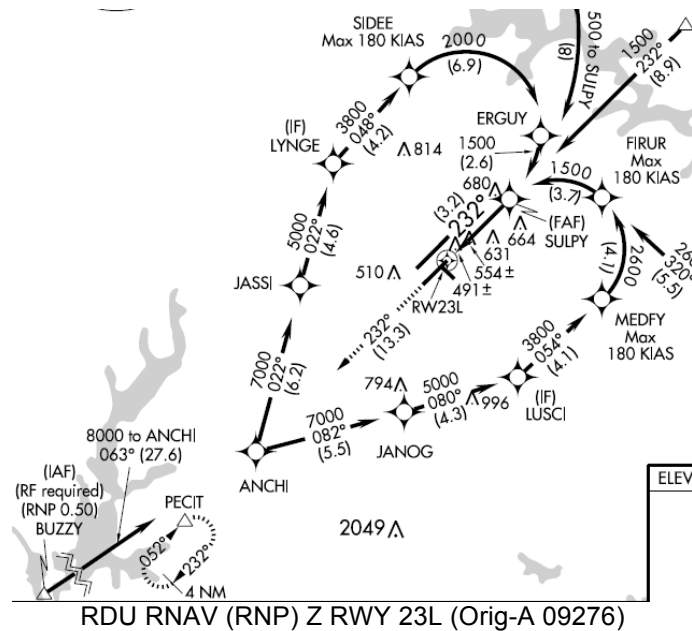

5. RNAV STAR considerations when designing RNP SAAAR IAPs. RNAV STARs should be considered during Instrument Approach Procedure (IAP) design. Developing RNAV STARs in conjunction with RNAV SAAAR approach procedures can reduce the length and/or number of legs on the IAP and thereby reduce approach chart clutter.
6. RNAV STARs developed in conjunction with RNP SAAAR IAPs. STARs designed in conjunction with RNP SAAAR procedures should be available to all users i.e. they should be RNAV-1 or RNP-1.
7. Suffixed Procedure Option (e.g. KPSP RNAV (RNP) Y Rwy 13R, KPSP RNAV (RNP) Z Rwy 13R). When a procedure has an excessive number of transitions or legs it may be divided into two or more suffixed procedures. This option should be used sparingly and only after other more desirable alternatives have been considered (e.g. use of RNAV STAR).

8. A single Intermediate Fix (IF) results in the simplest charting option. During procedure design using a single IF normally results in the simplest charting product. Providing guidelines on when multiple IFs are acceptable or beneficial was deemed out of scope for this charting group.
9. Multiple IFs are restricted to RNP SAAAR procedures.
10. Do not depict an Intermediate Segment in the Profile View when Multiple IFs exist. (Exception: Electronic Charting, see recommendation #12 in this paper.) When multiple Intermediate Fixes (IFs) are required in RNP SAAAR procedures the Profile View will not include a depiction of the Intermediate Segment.

Note: This recommendation should be evaluated during the proposed Volpe research which will review both RNP SAAAR and non-SAAAR RNP approaches.
11. Depict the Intermediate Segment when there is a single IF. The Intermediate Segment should be depicted in the Profile View when there is a single IF.
12. Electronic Charting Options. Electronic, data driven charts have the potential to dynamically display the entire Intermediate Segment Profile View based on the IAF/IF selected. Therefore, even when multiple IFs exist electronic charts can provide the flexibility to depict the single Intermediate Segment Profile View associated with the selected IF. Electronic charts should not be restricted from depicting the applicable Intermediate Segment when the system has the capability to do so.

Annex

This section documents the issues that were considered out-of-scope for charting but that needed to be addressed for a successful implementation of RNP SAAAR.

Issue 1. Direct to IF clearances

ATC can issue clearances to proceed direct to the IF involving a turn of up to 90°. (FAA Order 7110.65 states “Established on a heading or course that will intercept the initial segment at the initial approach fix, or intermediate segment at the intermediate fix when no initial approach fix is published, for a GPS or RNAV instrument approach procedure at an angle not greater than 90 degrees.”) Turn anticipation and subsequent roll-out on course between the IF and PFAF may require up to approximately 1 - 3NM (depending on ground speed and aircraft bank angle).

The group recognized that placing an IF close to the PFAF may lead to operational problems because there is inadequate harmonization between the current guidance in 7110.65 and 8260.52. An IF may be located as close as 0.6 NM from the PFAF in an RNP SAAAR procedure. A Category D aircraft cleared direct to the IF for an approach (on a 90° intercept angle) will not roll out and be within the acceptable cross track tolerance until after the PFAF (and in the Final Segment). This has operational implications because a vertical path (starting no later than the PFAF) is a feature of RNP SAAAR. Thus, in this example the aircraft will either:

- a) Commence the vertical path descent when possibly outside of TERPS protected airspace and not fully established on a segment of the approach or,
- b) The pilot will delay the descent until within acceptable cross track limits and then be high-on-profile (and outside of the +/- 75' tolerance required in AC 90-101).

Additional issues involving the Minimum Vectoring Altitude (MVA) relationship with the IF altitude and other elements also require consideration. An in-depth presentation of the issue was presented to the PARC on Thursday 25 February 2010 by the NBAA. The PARC concluded that this issue will be forwarded to the Instrument Procedures Group (IPG) of the Air Charting Forum (ACF).

Resolution of this issue was beyond the scope of the RNP Charting WG.

Recommendation: The PARC should forward this issue for resolution to the FAA.

NOTE: This issue has previously been raised – see reference ATPAC AOC102-2.

Issue 2. Vectoring to extended straight-in

There was concern that if an aircraft was vectored off a procedure and then vectored to intercept the procedure path prior to the PFAF it could be more difficult to determine the minimum step-down altitudes and location of fixes prior to the PFAF using only the Plan View. This could be problematic if the pilot used a “direct intercept to” function on the FMS and eliminated step-down fixes located in the straight-in Intermediate Segment.

Recommendation: Issue should be forwarded to FAA ATO/AFS to determine whether additional guidance or training is required for Air Traffic Controllers and/or pilots.

Issue 3. Aircraft Displays.

The group recognized that the additional training requirements inherent to RNP SAAAR and the more advanced flight deck displays that typify RNP SAAAR approved aircraft can mitigate the absence of a Profile View depiction of the Intermediate Segment. (A detailed discussion of the AC 90-101 display requirements and acceptable deviations from the requirements was deemed important but beyond the scope of this group). The group believed that the importance of the Intermediate Segment chart depiction was significantly higher when flying procedures on aircraft that lack adequate Navigation Displays, moving maps, and/or FMS'.

Recommendation: The Volpe human factors research should investigate the relationship and/or mitigation provided by ‘advanced’ cockpit displays that provide significant procedural charting information e.g. altitudes at waypoints, etc. A question that needs addressing is whether the absence of an Intermediate Segment Profile View depiction is acceptable for non SAAAR operations. Ideally the research may indicate whether aircraft with moving map displays mitigate the absence of an Intermediate Segment Profile View.

Issue 4. Weighing the benefits between single and multiple IFs.

Weighing the benefits gained from the use of multiple IFs versus a single IF against the increased charting and/or operational complexities of multiple IFs. The group recognized that this issue was out-of-scope. Additionally, the group membership lacked key stake holders to resolve this issue. There were significant differences of opinion on the relative merits and benefits of procedures with multiple or single IFs.

Recommendation: Additional information regarding the use of multiple IFs should be included in procedure design guidance. The PARC should either forward this issue for resolution to the FAA or coordinate with the FAA to delegate the issue to a PARC WG for resolution.

Issue 5: Non-SAAAR application of multiple IFs

It is unclear if FAA Order 8260.54A permits the use of multiple IFs in RNAV (GPS) procedures. Traditionally RNAV (GPS) procedures have been designed with a single IF. Recommendation #9 restricts multiple IFs to SAAAR which may be more restrictive than the criteria in 8260.54A.

Recommendation: After the Volpe human factors research is completed, recommendation #9 should be revisited by the FAA/PARC to determine whether criteria in 8260.54A needs revision or whether the employment of multiple IFs in non-SAAAR procedures is acceptable.

Recommendations submitted to the PARC on 12 March 2010.

Pedro Rivas
PARC RNP Charting WG Lead

Appendix

BOISE, IDAHO

AL-57 (FAA)

APP CRS	Rwy Idg	9763
280°	TDZE	2858
	Apt Elev	2871

RNAV (RNP) Z RWY 28L
BOISE AIR TERMINAL (GOWEN FIELD) (BOI)

GPS required. For uncompensated Baro-VNAV systems, procedure NA below -14°C (7°F) or above 42°C (107°F). For inoperative MALSR increase RNP 0.15 and RNP 0.25 visibility to RVR 6000, and RNP 0.30 to 1½. MALSR MISSED APPROACH: Climb to 6000 via track 280° to JIMMI and hold, continue climb-in-hold to 6000.

ATIS	BOISE APP CON	BOISE TOWER	GND CON	CLNC DEL
123.9 290.4	119.6 269.4	118.1 257.8	121.7 348.6	125.9 323.2

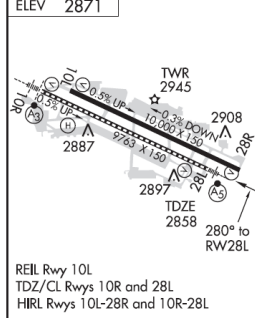
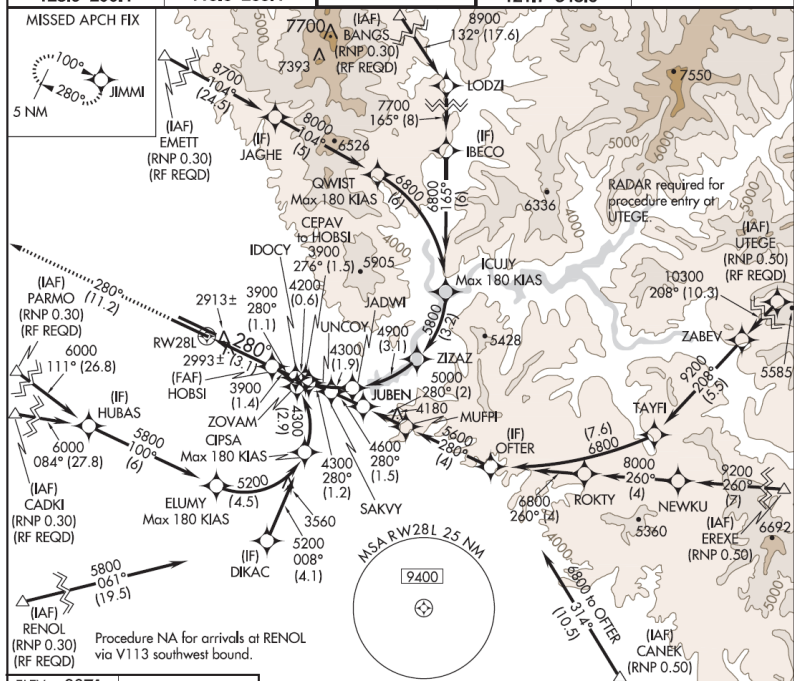

	<table border="1"> <tr> <th>CATEGORY</th> <th>A</th> <th>B</th> <th>C</th> <th>D</th> </tr> <tr> <td>RNP 0.15 DA</td> <td></td> <td>3228/40</td> <td>370 (400-¾)</td> <td></td> </tr> <tr> <td>RNP 0.25 DA</td> <td></td> <td>3250/50</td> <td>392 (400-1)</td> <td></td> </tr> <tr> <td>RNP 0.30 DA</td> <td></td> <td>3315/60</td> <td>457 (500-1¼)</td> <td></td> </tr> </table>				CATEGORY	A	B	C	D	RNP 0.15 DA		3228/40	370 (400-¾)		RNP 0.25 DA		3250/50	392 (400-1)		RNP 0.30 DA		3315/60	457 (500-1¼)	
	CATEGORY	A	B	C	D																			
	RNP 0.15 DA		3228/40	370 (400-¾)																				
RNP 0.25 DA		3250/50	392 (400-1)																					
RNP 0.30 DA		3315/60	457 (500-1¼)																					
<p>SPECIAL AIRCRAFT & AIRCREW AUTHORIZATION REQUIRED</p>																								
<p>REIL Rwy 10L TDZ/CL Rwys 10R and 28L HIRL Rwys 10L-28R and 10R-28L</p>																								

BOISE, IDAHO
Orig Pre-pub

BOISE AIR TERMINAL (GOWEN FIELD) (BOI)
43°34'N-116°13'W **RNAV (RNP) Z RWY 28L**

RALEIGH/DURHAM, NORTH CAROLINA

AL-516 (FAA)

RNAV (RNP) Z RWY 23R

RALEIGH-DURHAM INTL (RDU)

APP CRS	Rwy Idg	10000
232°	TDZE	409
	Apt Elev	435

GPS Required. For uncompensated Baro-VNAV systems, procedure NA below -10°C (13°F) or above 47°C (116°F). For inoperative ALSF, increase RNP 0.15 all Cats visibility to RVR 6000 and RNP 0.30 all Cats visibility to 2.



MISSED APPROACH: Climb to 3000 via track 232° to SCHOO and hold.

ATIS	RALEIGH APP CON	(EAST) RALEIGH TOWER (WEST)	(EAST) GND CON (WEST)	CLNC DEL
123.8	128.3 307.9	127.45 257.8 Rwys 5R-23L and 14-32	119.3 257.8 Rwy 5L-23R	120.1
		121.9 348.6 Rwys 5R-23L and 14-32	121.7 348.6 Rwy 5L-23R	

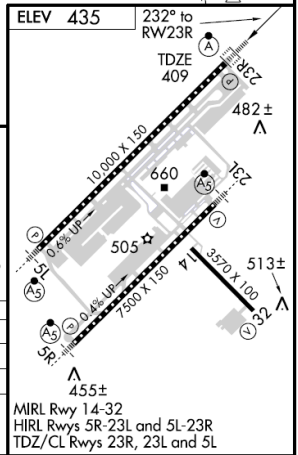
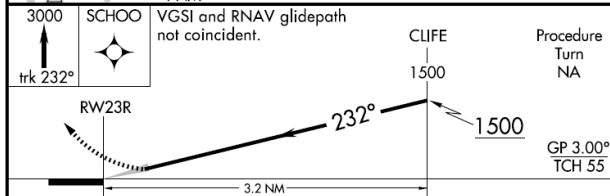
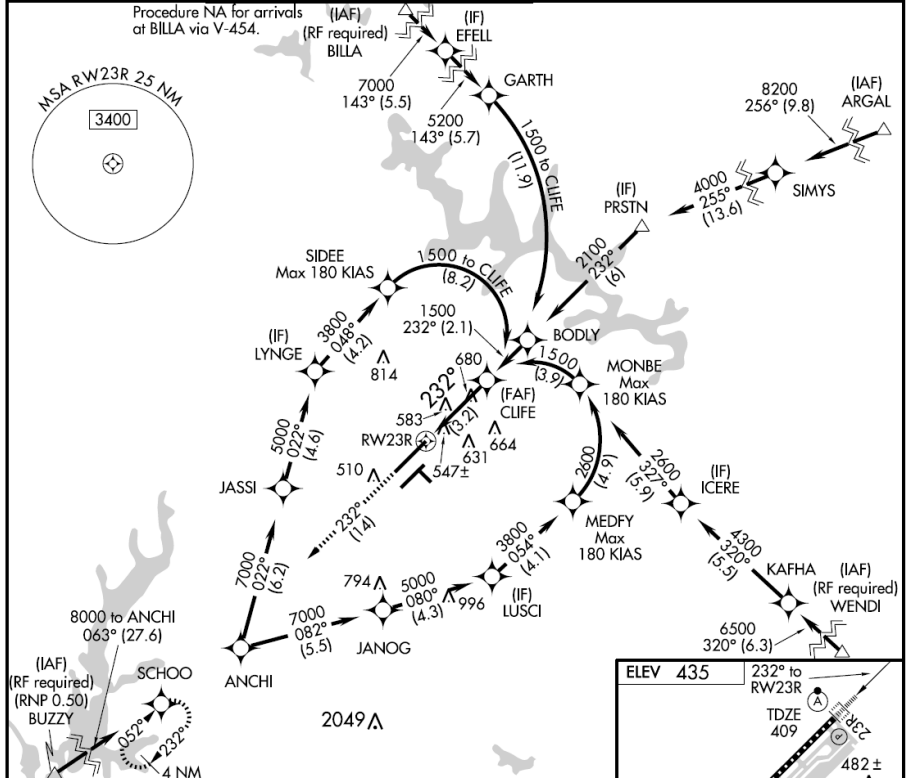

CATEGORY	A	B	C	D
RNP 0.15 DA		780/40	371 (400-¾)	
RNP 0.30 DA		958/1½	549 (600-1½)	

SPECIAL AIRCRAFT AND AIRCREW AUTHORIZATION REQUIRED

RALEIGH/DURHAM, NORTH CAROLINA
Orig 09239

RALEIGH-DURHAM INTL (RDU)
35°53'N-78°47'W **RNAV (RNP) Z RWY 23R**

Appendix C: List of Procedures Analyzed for Chart Review

C1: Approach Procedures Analyzed for Chart Review

Problematic Group (18)	Baseline Group (45)
<p>Scottsdale (SDL) RNAV (RNP) RWY 21 RNAV (RNP) Y RWY 3 RNAV (RNP) Z RWY 3</p> <p>Boise (BOI) RNAV (RNP) Z RWY 10L RNAV (RNP) Z RWY 10R RNAV (RNP) Z RWY 28L RNAV (RNP) Z RWY 28R</p> <p>Palm Springs (PSP) RNAV (RNP) Y RWY 13R RNAV (RNP) Y RWY 31L RNAV (RNP) Z RWY 13R</p> <p>Rifle (RIL) RNAV (RNP) Z RWY 8 RNAV (RNP) Y RWY 26</p> <p>Bozeman (BZN) RNAV (RNP) Z RWY 12 RNAV (RNP) RWY 30</p> <p>Lewiston (LWS) RNAV (RNP) RWY 30 RNAV (RNP) Z RWY 8 RNAV (RNP) Z RWY 12 RNAV (RNP) Z RWY 26</p>	<p>Atlanta (ATL) RNAV (RNP) Z RWY 8L RNAV (RNP) Z RWY 8R RNAV (RNP) Z RWY 9L RNAV (RNP) Z RWY 9R RNAV (RNP) Z RWY 10 RNAV (RNP) Z RWY 26L RNAV (RNP) Z RWY 26R RNAV (RNP) Z RWY 27L RNAV (RNP) Z RWY 27R RNAV (RNP) Z RWY 28</p> <p>San Francisco (SFO) RNAV (RNP) Y RWY 28R RNAV (RNP) Y RWY 10R</p> <p>Baltimore-Washington (BWI) RNAV (RNP) Z RWY 10 RNAV (RNP) Z RWY 15R RNAV (RNP) Z RWY 28 RNAV (RNP) Z RWY 33L</p> <p>Cincinnati-Covington (CVG) RNAV (RNP) Z RWY 18C RNAV (RNP) Z RWY 18L RNAV (RNP) Z RWY 18R RNAV (RNP) Z RWY 27 RNAV (RNP) Z RWY 36C RNAV (RNP) Z RWY 36L RNAV (RNP) Z RWY 36R RNAV (RNP) Z RWY 9</p> <p>Washington National (DCA) RNAV (RNP) RWY 19 RNAV (RNP) RWY 1</p> <p>Dallas-Fort Worth (DFW) RNAV (RNP) Z RWY 13R RNAV (RNP) Z RWY 31L RNAV (RNP) Z RWY 31R</p> <p>Washington Dulles (IAD) RNAV (RNP) Z RWY 1R RNAV (RNP) Z RWY 1C RNAV (RNP) Z RWY 19L RNAV (RNP) Z RWY 19C</p> <p>Fort Lauderdale (FLL) RNAV (RNP) Y RWY 09L RNAV (RNP) Z RWY 09R RNAV (RNP) Z RWY 27R</p>

	<p>La Guardia (LGA) RNAV (RNP) Z RWY 22 RNAV (RNP) Z RWY 04</p> <p>Chicago Midway (MDW) RNAV (RNP) Y RWY 13C</p> <p>Miami (MIA) RNAV (RNP) Y RWY 08R RNAV (RNP) Y RWY 12 RNAV (RNP) Y RWY 26L RNAV (RNP) Y RWY 27 RNAV (RNP) Y RWY 30</p> <p>Tampa (TPA) RNAV (RNP) Y RWY 19L</p>
--	---

C2: Departure Procedures Analyzed for Chart Review

<u>Problematic Group (37)</u>	<u>Baseline Group (15)</u>
<p>Atlanta (ATL) DAWGS FIVE BRAVS SIX CADIT SIX COKEM FIVE DOOLY FIVE GEETK SIX</p> <p>Boston (BOS) WYLYY ONE</p> <p>Baltimore/Washington (BWI) TERPZ TWO</p> <p>Dallas-Fort Worth (DFW) NOBLY THREE TRISS THREE CEOLA FOUR DARTZ THREE FERRA FOUR AKUNA THREE CLARE TWO JASPA TWO LOWGN THREE NELYN TWO PODDE THREE SLOTT THREE SOLDO TWO ARDIA THREE BLECO TWO GRABE THREE</p> <p>Washington Dulles (IAD) STOIC TWO</p> <p>Las Vegas (LAS) BOACH FOUR COWBY FOUR PRFUM TWO SHEAD SEVEN STAAV FOUR TRALR FOUR</p> <p>Los Angeles (LAX) HOLTZ NINE</p> <p>Miami (MIA) WINCO ONE</p> <p>Seattle (SEA) HAROB THREE</p> <p>Salt Lake City (SLC) WEVIC TWO LEETZ TWO</p>	<p>Cleveland-Hopkins (CLE) ALPHE THREE</p> <p>Cincinnati-Covington (CVG) BNGLE THREE HAGOL THREE</p> <p>Newark (EWR) PORTT TWO</p> <p>Fort Lauderdale (FLL) BAHMA TWO THNDR ONE</p> <p>George Bush Intercontinental/Houston (IAH) GUSTI ONE</p> <p>John F. Kennedy (JFK) SKORR THREE</p> <p>La Guardia (LGA) NTHNS ONE TREEO ONE</p> <p>Phoenix (PHX) BARGN ONE SMALL ONE</p> <p>San Diego (SAN) POGGI TWO</p> <p>Tampa (TPA) BAYPO FOUR GANDY FOUR</p>

PECOP TWO	
-----------	--

C3: Arrival Procedures Analyzed for Chart Review

<u>Problematic Group (34)</u>	<u>Baseline Group (20)</u>
Atlanta (ATL) HONIE EIGHT CANUK ONE ERLIN NINE FLCON SEVEN HERKO SIX PEECHY SEVEN	Cincinnati-Covington (CVG) SARGO TWO TIGRR TWO
Boston (BOS) KRANN ONE	Houston (HOU) COACH ONE COLUMBIA ONE
Baltimore-Washington (BWI) RAVNN THREE	Newark (EWR) PHLBO TWO FLOSI ONE
Charlotte (CLT) SUDSY FOUR HUSTN TWO JOHNS THREE ADENA THREE	John F. Kennedy (JFK) PARCH ONE
Washington National (DCA) ELDEE FIVE	Orlando (MCO) BAIRN TWO PIGLT TWO
George Bush Intercontinental/Houston (IAH) TXMEX ONE ROKIT ONE	Memphis (MEM) BEERT FOUR TAMMY THREE
Washington Dulles (IAD) BARIN ONE SHANON TWO	West Palm Beach (PBI) WLACE TWO FRWAY THREE
Las Vegas (LAS) GRNPA ONE KEPEC TWO TYSSN THREE SUNST TWO	Pittsburg (PIT) DEMME ONE JESEY ONE
Chicago (ORD) ROYKO THREE	San Diego (SAN) BAYVU ONE LYNDI TWO
Philadelphia (PHL) GUNNI TWO	San Francisco (SFO) YOSEM ONE
Phoenix Sky Harbor (PHX) GEELA FIVE KOOLY FOUR MAIER FIVE EAGUL FIVE	Tampa (TPA) DADES THREE DEAKK THREE
Salt Lake City (SLC) SKEES THREE QWENN THREE NORDK THREE LEEHY THREE DELTA THREE	

BEARR FOUR	
------------	--

Teterboro (TEB) JAIKE THREE	
---------------------------------------	--

This Page Intentionally Left Blank

Appendix D. Summary Chart Review Data by Airport

D1: Approach Procedures

	Airport code	Number of IAFs	Number of IFs	Number of segments in MAP	Number of RF legs in MAP	Number of waypoints from IAF to Runway	Number of waypoints between IF to FAF	Number of RF legs from IAF to Runway	Distance from IF to FAF	Number of waypoints between FAF to runway	Distance from FAF to runway	Number of altitude constraints	Vertical profile starts with
Baseline	ATL	1	1	2.4	0	4.7	1	0	7.1	0	5.2	0	IAF
	BWI	1.25	1	1	0	2.5	0.3	0	6.9	0	4.9	2.5	IF
	CVG	1	1	2	0	4.1	0.9	0	6.7	0	4.6	0	IAF
	DCA	2	2	1	0	3	0	2.5	4.7	2.5	5.3	0	IF
	DFW	0.7	1	1.3	0.7	3.7	1	0	9.3	0	5.4	0	IF
	FLL	2	1	1.7	0	3	0	0	6.2	0	5.8	2	IF
	IAD	2	1	1.5	0	3.5	0	0.5	9.0	0	4.7	0	IF
	LGA	1.5	1	1.5	0	4	0	0.5	7.3	1	4.9	0	IF
	MDW	1	1	2	0	6	2	2	14.9	1	4.2	3	IF
	MIA	2	1	2	0	4.1	1	0	9.3	0	4.9	0.8	IF
	MSP	3	1	2	0	3	0	0	6.8	0	6.5	0	IF
	SFO	1	1	2.5	0.5	4	0	0	5.8	1	5.6	0	IF
TPA	3	1	2	0	4.3	1	0	8.1	0	6	2	IF	
Problematic	BOI	8	5	1.5	0	6.1	2.9	6	11.8	0	3	0	FAF
	BZN	4.5	3.5	2.5	0.5	6.6	4	4.5	13.4	0	3.6	0	FAF
	LWS	3.5	3.5	2.3	0.8	6.4	0.8	2	6.9	0.7	6.4	0	FAF
	PSP	3.7	1	2.3	0.3	6.9	1.3	6	8	0.7	7.4	3.4	IF
	RIL	3.5	1	4	1.5	6	1.5	2.5	10	1	6.8	0	IF
	SDL	1.3	1	5	3	6	0.7	1.3	9.6	0.7	5.7	1.5	IF

D2: Departure Procedures

	Airport Code	Number of Paths	'At or Above' constraints	'Mandatory' constraints	'At or Below' constraints	MEA	MOCA	'ATC Expect' altitudes	Number of speed restrictions	Number of Waypoints	Total Path Lengths	Mean distance between waypoints
Baseline	CLE	6	1	0	0	1	1	0	0	3	121	40.3
	CVG	7	0.6	0	0	2	2	0	0	6.6	141.5	25.8
	EWR	8	1	0	0	3	3	0.25	0	5	41	8.2
	FLL	4.5	1	0	0	0	0	0.5	0.5	6	69.3	11.6
	IAH	1	0	0	0	4	4	0	0	4	271	67.8
	JFK	4	2	0	0	1	1	0	1	4	18	9
	LGA	2.5	3	0	2.5	3.5	3.5	0	2.5	6.5	55.5	8.7
	PHX	9	0	0	0	5.8	0	0	0.5	8.3	266	31.3
	SAN	2	0	0	2	2	0	0	1	5	85	17
TPA	6	1	0	0	3.8	3.8	0	0	5.8	131.3	20.2	
Problematic	ATL	10	0.7	0	0	1	1	0	0.7	5.9	120.0	25.1
	BOS	1	1	0	0	1	1	0	1	2	11	5.5
	BWI	36	1	0	0	1.7	3.3	0	0.92	5.5	55.7	10.1
	DFW	10.5	2.0	0	0	2.8	0	0	1	7.25	247.5	44.8
	IAD	28	0	0	0	5.5	5.5	0	0	5.5	61.5	11.0
	LAS	13.5	2.5	0.25	0.8	1.8	1.4	0.06	0.2	6.9	204.9	31.6
	LAX	4	1	0	2	1	0	0	0	6.5	140	21.7
	MIA	8	1	0	0	1	1	0	0.5	5	52	10.4
	SEA	18	1	0	0	1	1	0	0	6.3	119.8	18.5
SLC	15	2.3	0.25	1	4.0	4.0	0.8	2	8.7	204.0	25.6	

D3: Arrival Procedures

	Airport Code	Number of Paths	'At or Above' constraints	'Mandatory' constraints	'At or Below' constraints	MEA	MOCA	'ATC Expect' altitudes	Number of speed restrictions	Number of Waypoints	Overall Distance per Path	Distance between waypoints	Number of holding points
Baseline	CVG	1.5	0.0	0.0	0.0	3.5	0.0	3.0	1.5	10.3	278.5	27.9	3.3
	EWR	13.5	1.5	1.0	0.0	5.8	0.0	1.0	2.0	12.0	197.3	16.4	3.7
	FLL	4.0	0.0	0.0	0.0	5.1	0.0	2.3	1.5	8.9	172.4	19.5	2.1
	HOU	10.0	0.0	0.0	0.0	7.3	0.0	1.0	1.0	10.3	222.7	21.3	1.2
	IAH	11.7	0.0	0.1	0.0	6.2	0.0	1.0	1.1	7.3	189.6	26.7	1.0
	JFK	24.0	0.0	0.0	0.0	5.4	2.7	3.3	0.0	7.1	175.2	24.3	2.7
	MCO	2.5	0.0	0.0	0.0	4.9	0.0	1.5	1.0	8.4	126.5	15.3	1.3
	MEM	4.5	0.0	0.0	0.0	3.6	0.0	2.0	0.0	8.3	198.1	23.7	2.9
	PBI	4.0	0.0	0.0	0.0	5.4	0.0	2.3	0.0	9.4	198.7	20.0	2.4
	SAN	3.0	3.9	0.5	1.0	6.3	4.0	0.5	1.0	7.4	108.8	14.9	0.4
SFO	2.0	0.0	0.0	0.0	4.0	0.0	3.0	0.0	8.0	210.5	26.3	0.0	
TPA	5.0	0.0	0.0	0.0	3.7	0.0	1.0	0.4	6.3	111.9	18.6	1.5	
Problematic	ATL	14.8	1.0	2.3	0.0	3.8	0.0	0.2	1.8	11.1	267.1	24.0	2.7
	BOS	3.0	3.0	5.3	0.0	5.3	0.0	0.0	2.7	13.7	191.3	14.1	1.0
	BWI	6.0	0.5	3.5	0.0	6.5	0.0	1.0	0.0	9.5	112.5	12.0	1.5
	CLT	3.0	0.0	0.0	0.0	4.6	0.0	0.8	0.0	11.1	189.7	17.4	2.8
	DCA	3.0	2.0	4.0	0.0	6.3	0.0	2.0	0.0	15.7	218.7	13.7	3.7
	IAD	10.0	0.0	3.3	0.0	3.3	0.0	1.3	1.0	9.5	150.5	15.6	1.8
	LAS	2.6	0.8	3.5	0.4	4.7	0.0	0.0	3.0	9.1	159.2	18.0	1.5
	ORD	2.0	0.0	0.0	0.0	6.0	0.0	0.0	0.0	13.0	178.0	13.7	2.0
	PHL	6.0	0.0	0.0	0.0	9.2	0.0	0.0	1.0	9.7	187.8	19.3	2.0
	PHX	11.0	1.3	5.8	0.7	8.2	3.8	0.0	5.4	11.8	153.4	13.2	2.9
	SLC	9.7	0.3	2.2	0.0	5.8	0.0	0.8	0.2	9.6	203.4	21.0	2.8
TEB	5.0	0.0	3.0	0.0	2.0	0.0	1.0	3.0	13.2	210.2	15.9	2.4	

Appendix E. Clearances and Questions used for the Information Retrieval Task

E1: Clearances and Questions for Approach Procedures

Procedure Name	Question Type	Clearance	Question
BOI: RNAV (RNP) Z RWY 28L	DISTANCE	You are cleared to Boise Air Terminal (BOI) for the RNAV (RNP) Z RWY 28L via EMETT	What is the distance from ZIZAZ to JADWI?
	DISTANCE	You are cleared to Boise Air Terminal (BOI) for the RNAV (RNP) Z RWY 28L via BANGS	What is the distance from JADWI to UNCOY?
	TRACK	You are cleared to Boise Air Terminal (BOI) for the RNAV (RNP) Z RWY 28L via RENOL	What is the track from DIKAC to CIPSA?
	TRACK	You are cleared to Boise Air Terminal (BOI) for the RNAV (RNP) Z RWY 28L via EREXE	What is the track from NEWKU to ROKTY?
	SPEED	You are cleared to Boise Air Terminal (BOI) for the RNAV (RNP) Z RWY 28L via PARMO	What is the maximum allowed speed at ELUMY
	ALTITUDE	You are cleared to Boise Air Terminal (BOI) for the RNAV (RNP) Z RWY 28L via CADKI	What is the minimum altitude required from ZOVAM to HOBSI?
	ALTITUDE	You are cleared to Boise Air Terminal (BOI) for the RNAV (RNP) Z RWY 28L via CANEK	What is the minimum altitude required from SAKVY to CEPAV?
	ALTITUDE	You are cleared to Boise Air Terminal (BOI) for the RNAV (RNP) Z RWY 28L via UTEGE	What is the minimum altitude required from ZABEV to TAYFI?
	NOTES	You are cleared to Boise Air Terminal (BOI) for the RNAV (RNP) Z RWY 28L via UTEGE	Other than GPS, what other equipment is required for procedure entry of UTEGE?
	GENERAL (Inside)	You are cleared for Boise Air Terminal (BOI) for the RNAV (RNP) Z RWY 28L via BANGS	What is the missed approach hold fix?
	GENERAL (outside)	You are cleared to Boise Air Terminal (BOI) for the RNAV (RNP) Z RWY 28L via CADKI	What is the length of the landing runway?
	GENERAL (outside)	You are cleared to Boise Air Terminal (BOI) for the RNAV (RNP) Z RWY 28L via BANGS	What is the ATIS frequency?
	DISTANCE	You are cleared to Boise Air Terminal (BOI) for the RNAV (RNP) Z RWY 28L via UTEGE	What is the distance from MUFPI to JUBEN?
	DISTANCE	You are cleared to Boise Air Terminal (BOI) for the RNAV (RNP) Z RWY 28L via CADKI	What is the distance from ZOVAM to HOBSI?
	TRACK	You are cleared to Boise Air Terminal (BOI) for the RNAV (RNP) Z RWY 28L via BANGS	What is the track from LODZI to IBECO?

	TRACK	You are cleared to Boise Air Terminal (BOI) for the RNAV (RNP) Z RWY 28L via CANEK	What is the track from CANEK to OFTER?
	SPEED	You are cleared to Boise Air Terminal (BOI) for the RNAV (RNP) Z RWY 28L via RENOL	What is the allowed maximum speed at CIPSA?
	ALTITUDE	You are cleared to Boise Air Terminal (BOI) for the RNAV (RNP) Z RWY 28L via EREXE	What is the minimum altitude required from JUBEN to SAKVY?
	ALTITUDE	You are cleared to Boise Air Terminal (BOI) for the RNAV (RNP) Z RWY 28L via EMETT	What is the minimum altitude required from UNCOY to IDOCY?
	ALTITUDE	You are cleared to Boise Air Terminal (BOI) for the RNAV (RNP) Z RWY 28L via PARMO	What is the minimum altitude required from ELUMY to CIPSA?
	NOTES	You are cleared to Boise Air Terminal (BOI) for the RNAV (RNP) Z RWY 28L via RENOL	This procedure is not available for arrivals at RENOL via which victor airway?
	GENERAL (inside)	You are cleared for Boise Air Terminal (BOI) for the RNAV (RNP) Z RWY 28L via CANEK	What is the track from runway to missed approach point?
	GENERAL (outside)	You are cleared to Boise Air Terminal (BOI) for the RNAV (RNP) Z RWY 28L via PARMO	What is the Airport Elevation?
	GENERAL (outside)	You are cleared to Boise Air Terminal (BOI) for the RNAV (RNP) Z RWY 28L via EMETT	What is Ground Control communication frequency?
BZN: RNAV (RNP) Z RWY 12	DISTANCE	You are cleared to Gallatin Field Airport (BZN) for the RNAV (RNP) Z RWY 12 via JOXIT	What is the distance from WOMET to the next waypoint?
	TRACK	You are cleared to Gallatin Field Airport (BZN) for the RNAV (RNP) Z RWY 12 via WHITEHALL	What is the track from THESE to HUXAN?
	SPEED	You are cleared to Gallatin Field Airport (BZN) for the RNAV (RNP) Z RWY 12 via LIVINGSTON	What is the maximum allowed speed at WINIX?
	ALTITUDE	You are cleared to Gallatin Field Airport (BZN) for the RNAV (RNP) Z RWY 12 via GODFE	What is the minimum altitude required from WOSAG to JURAL?
	NOTES	You are cleared to Gallatin Field Airport (BZN) for the RNAV (RNP) Z RWY 12 via JOXIT	What is the minimum RNP value required for procedure entry via JOXIT?
	GENERAL (Inside)	You are cleared to Gallatin Field Airport (BZN) for the RNAV (RNP) Z RWY 12 via LIVINGSTON	What is the missed approach hold fix?
	GENERAL (outside)	You are cleared to Gallatin Field Airport (BZN) for the RNAV (RNP) Z RWY 12 via WHITEHALL	What is the airport elevation?
	GENERAL (outside)	You are cleared to Gallatin Field Airport (BZN) for the RNAV (RNP) Z RWY 12 via THESE	What is the ATIS frequency?
	DISTANCE	You are cleared to Gallatin Field Airport (BZN) for the RNAV (RNP) Z RWY 12 via LIVINGSTON	What is the distance from GATEY to the next waypoint?

	TRACK	You are cleared to Gallatin Field Airport (BZN) for the RNAV (RNP) Z RWY 12 via GODFE	What is the track from ZIVTI to HUXAN?
	SPEED	You are cleared to Gallatin Field Airport (BZN) for the RNAV (RNP) Z RWY 12 via JOXIT	What is the allowed maximum speed at TETBY?
	ALTITUDE	You are cleared to Gallatin Field Airport (BZN) for the RNAV (RNP) Z RWY 12 via WHITEHALL	What is the minimum altitude required from THESE to HUXAN?
	NOTES	You are cleared to Gallatin Field Airport (BZN) for the RNAV (RNP) Z RWY 12 via LIVINGSTON	What is the minimum RNP value required for procedure entry via LIVINGSTON?
	GENERAL (inside)	You are cleared to Gallatin Field Airport (BZN) for the RNAV (RNP) Z RWY 12 via GODFE	What is the missed approach track from HAXAG to THESE?
	GENERAL (outside)	You are cleared to Gallatin Field Airport (BZN) for the RNAV (RNP) Z RWY 12 via THESE	What is the TDZE?
	GENERAL (outside)	You are cleared to Gallatin Field Airport (BZN) for the RNAV (RNP) Z RWY 12 via JOXIT	What is Ground Control communication frequency?
PSP: RNAV (RNP) Y RWY 31L	DISTANCE	You are cleared to Palm Springs Airport (PSP) for the RNAV (RNP) Y RWY 31L via BALDI	What is the distance from BALDI to the next waypoint?
	TRACK	You are cleared to Palm Springs Airport (PSP) for the RNAV (RNP) Y RWY 31L via PALM SPRINGS	What is the track from PSP to HIXOV?
	SPEED	You are cleared to Palm Springs Airport (PSP) for the RNAV (RNP) Y RWY 31L via SBONO	What is the maximum allowed speed at SBONO?
	ALTITUDE	You are cleared to Palm Springs Airport (PSP) for the RNAV (RNP) Y RWY 31L via CLOWD	What is the altitude constraint at WEMIR?
	ALTITUDE	You are cleared to Palm Springs Airport (PSP) for the RNAV (RNP) Y RWY 31L via PALM SPRINGS	What is the altitude constraint at HIXOV?
	NOTES	You are cleared to Palm Springs Airport (PSP) for the RNAV (RNP) Y RWY 31L via TRM	What is the minimum RNP value required for procedure entry via TRM?
	GENERAL (inside)	You are cleared to Palm Springs Airport (PSP) for the RNAV (RNP) Y RWY 31L via BALDI	What is the minimum climb gradient for missed approach to 3000 feet?
	GENERAL (Inside)	You are cleared to Palm Springs Airport (PSP) for the RNAV (RNP) Y RWY 31L via TRM	What is the final approach course?
	DISTANCE	You are cleared to Palm Springs Airport (PSP) for the RNAV (RNP) Y RWY 31L via PALMS SPRINGS	What is the distance from HIXOV to the next waypoint?
	TRACK	You are cleared to Palm Springs Airport (PSP) for the RNAV (RNP) Y RWY 31L via CLOWD	What is the track from RIYOC to TEVUC?
	SPEED	You are cleared to Palm Springs Airport (PSP) for the RNAV (RNP) Y RWY 31L via TRM	What is the maximum allowed speed at TRM?

	ALTITUDE	You are cleared to Palm Springs Airport (PSP) for the RNAV (RNP) Y RWY 31L via SBONO	What is the altitude constraint at RIYOC?
	ALTITUDE	You are cleared to Palm Springs Airport (PSP) for the RNAV (RNP) Y RWY 31L via BALDI	What is the altitude constraint at CUPOL?
	NOTES	You are cleared to Palm Springs Airport (PSP) for the RNAV (RNP) Z RWY 31L via PSP	What is the minimum RNP value required for procedure entry via PSP?
	GENERAL (outside)	You are cleared to Palm Springs Airport (PSP) for the RNAV (RNP) Z RWY 31L via SBONO	What is the decision altitude for RNP 0.30?
	GENERAL (outside)	You are cleared to Palm Springs Airport (PSP) for the RNAV (RNP) Z RWY 31L via CLOWD	What is the ATIS frequency?

E2: Clearances and Questions for Departure Procedures

SLC: LEETZ TWO DEPARTURE	DISTANCE	You are cleared to depart from Salt Lake City (SLC) via LEETZ TWO departure via MYTON	What is the distance from LOFOG to LEGBE?
	TRACK	You are cleared to depart from Salt Lake City (SLC) via LEETZ TWO departure via ROCK SPRINGS	What is the course from FEYOR to POPE?
	SPEED	You are cleared to depart from Salt Lake City (SLC) via LEETZ TWO departure via HOLTR	What is the speed restriction at MUCKI?
	ALTITUDE	You are cleared to depart from Salt Lake City (SLC) via LEETZ TWO departure via MEEKER	What is the altitude constraint at MURFI?
	NOTES	You are cleared to depart from Salt Lake City (SLC) via LEETZ TWO departure via HAYDEN	For non-GPS equipped aircraft, which DME(s) need to be operational?
	GENERAL	You are cleared to depart from Salt Lake City (SLC) via LEETZ TWO departure via MYTON via RWY 17	What is the Salt Lake City Tower Frequency?
	GENERAL	You are cleared to depart from Salt Lake City (SLC) via LEETZ TWO departure via HAYDEN via RWY 16R	What is the minimum climb gradient required up to 9000'
	GENERAL	You are cleared to depart from Salt Lake City (SLC) via LEETZ TWO departure via HOLTR	What is the altitude constraint at HUCKK
	DISTANCE	You are cleared to depart from Salt Lake City (SLC) via LEETZ TWO departure via HOLTR	What is the distance from FRALL to SAWGI?
	TRACK	You are cleared to depart from Salt Lake City (SLC) via LEETZ TWO departure via MEEKER	What is the course form MURFI to UPJAR
	SPEED	You are cleared to depart from Salt Lake City (SLC) via LEETZ TWO departure via ROCK SPRINGS	What is the speed restriction at PLOGE?
	ALTITUDE	You are cleared to depart from Salt Lake City (SLC) via LEETZ TWO departure via HAYDEN	What is the altitude constraint at CHEDO?
	NOTES	You are cleared to depart from Salt Lake City	For non-GPS equipped aircraft, which DME(s) need

		(SLC) via LEETZ TWO departure via MYTON	to be operational?
	GENERAL	You are cleared to depart from Salt Lake City (SLC) via LEETZ TWO departure via ROCK SPRINGS via RWY 16L	What is the GND Control Frequency?
	GENERAL	You are cleared to depart from Salt Lake City (SLC) via LEETZ TWO departure via HOLTR via RWY 17	What is the minimum climb gradient required up to 9000
	GENERAL	You are cleared to depart from Salt Lake City (SLC) via LEETZ TWO departure via HOLTR	What is the altitude constraint at ZEETA?
LAS: SHEAD SEVEN DEPARTURE	DISTANCE	You are cleared to depart from Las Vegas/Mc Carran International (LAS) via SHEAD SEVEN departure via RWY 19L	What is the distance from FIXIX TO ROPPR?
	TRACK	You are cleared to depart from Las Vegas/Mc Carran International (LAS) via SHEAD SEVEN departure via RWY 7R	What is the track required from JESJI to BAKRR?
	TRACK (substitute for SPEED)	You are cleared to depart from Las Vegas/Mc Carran International (LAS) via SHEAD SEVEN departure via RWY 25R	What heading should you maintain after takeoff from Runway 25R?
	ALTITUDE	You are cleared to depart from Las Vegas/Mc Carran International (LAS) via SHEAD SEVEN departure via RWY 7R	What is the altitude window constraint at BAKRR?
	NOTES	You are cleared to depart from Las Vegas/Mc Carran International (LAS) via SHEAD SEVEN departure via RWY 19R	For non-GPS equipped aircraft, which DME(s) must be operational?
	NOTES	You are cleared to depart from Las Vegas/Mc Carran International (LAS) via SHEAD SEVEN departure via RWY 7L	What is the minimum climb gradient required after departing runway 7L?
	GENERAL	You are cleared to depart from Las Vegas/Mc Carran International (LAS) via SHEAD SEVEN departure via RWY 25R	What is the tower frequency for your cleared runway?
	GENERAL	You are cleared to depart from Las Vegas/Mc Carran International (LAS) via SHEAD SEVEN departure via RWY 25L	What is the altitude constraint at MDDOG?

	DISTANCE	You are cleared to depart from Las Vegas/Mc Carran International (LAS) via SHEAD SEVEN departure via RWY 7L	What is the distance from MINEY to HITME?
	TRACK	You are cleared to depart from Las Vegas/Mc Carran International (LAS) via SHEAD SEVEN departure via RWY 25L	What is the track from PIRMD to ROPPR?
	SPEED	You are cleared to depart from Las Vegas/Mc Carran International (LAS) via SHEAD SEVEN departure via RWY 1L	What is the required maximum speed until BESSY?
	ALTITUDE	You are cleared to depart from Las Vegas/Mc Carran International (LAS) via SHEAD SEVEN departure via RWY 19R	What is the altitude window constraint at ROPPR?
	NOTES	You are cleared to depart from Las Vegas/Mc Carran International (LAS) via SHEAD SEVEN departure via RWY 7R	For non-GPS equipped aircraft, which DME(s) must be operational?
	NOTES	You are cleared to depart from Las Vegas/Mc Carran International (LAS) via SHEAD SEVEN departure via RWY 25R	What is the minimum climb gradient required after departing runway 25R?
	GENERAL	You are cleared to depart from Las Vegas/Mc Carran International (LAS) via SHEAD SEVEN departure via RWY 19L	What is the tower frequency for your cleared runway?
	GENERAL	You are cleared to depart from Las Vegas/Mc Carran International (LAS) via SHEAD SEVEN departure	What is the altitude constraint at TARRK?
DFW: DARTZ THREE DEPARTURE	DISTANCE	You are cleared to depart from Dallas-Fort Worth (DFW) via DARTZ THREE departure via 35C	What is the distance from OWLLS to SKTRR?
	TRACK	You are cleared to depart from Dallas-Fort Worth (DFW) via DARTZ THREE departure via 36L	What is the track from KELLR to MYGAL?
	SPEED	You are cleared to depart from Dallas-Fort Worth (DFW) via DARTZ THREE departure via 18L	What is the speed constraint at LARRN?
	ALTITUDE	You are cleared to depart from Dallas-Fort Worth (DFW) via DARTZ THREE departure via 17C	What is the altitude constraint at TREXX?
	NOTES	You are cleared to depart from Dallas-Fort Worth (DFW) via DARTZ THREE departure via 36L	For non-GPS equipped aircraft departing Runways 36L, which DME(s) must be operational?

	GENERAL	You are cleared to depart from Dallas-Fort Worth (DFW) via DARTZ THREE departure via 35L	What is the Departure control frequency?
	DISTANCE	You are cleared to depart from Dallas-Fort Worth (DFW) via DARTZ THREE departure via 17R	What is the distance from TREX to DALBY?
	TRACK	You are cleared to depart from Dallas-Fort Worth (DFW) via DARTZ THREE departure via 18L	What is the track from LARRN to LIZIE?
	SPEED	You are cleared to depart from Dallas-Fort Worth (DFW) via DARTZ THREE departure via 35L	What is the speed constraint at MAVVS?
	ALTITUDE	You are cleared to depart from Dallas-Fort Worth (DFW) via DARTZ THREE departure via 36R	What is the altitude constraint at KMART?
	NOTES	You are cleared to depart from Dallas-Fort Worth (DFW) via DARTZ THREE departure via 35C	What is the minimum climb gradient required for departure from Runway 35C?
	GENERAL	You are cleared to depart from Dallas-Fort Worth (DFW) via DARTZ THREE departure via 18R	What is the Departure control frequency?

This Page Intentionally Left Blank

Procedure Type	Airport	Code	Procedure Name	Total Questions	Questions per Question Type		
Approaches	DeKalb Peachtree, Georgia (Practice)	PDK	RNAV (RNP) Z RWY 20L	6	Path-Specific	Altitude	1
						Distance	1
						Track	1
						Speed	1
						Notes	1
					General	1	
	Boise, Idaho	BOI	RNAV (RNP) Z RWY 28L	24	Path-Specific	Altitude	6
						Distance	4
						Track	4
						Speed	2
						Notes	2
					General	6	
	Bozeman, Montana	BZN	RNAV (RNP) Z RWY 12	16	Path-Specific	Altitude	2
						Distance	2
						Track	2
						Speed	2
Notes						2	
General					6		
Palm Springs, California	PSP	RNAV (RNP) Y RWY 31L	16*	Path-Specific	Altitude	4*	
					Distance	2	
					Track	2	
					Speed	2	
					Notes	2	
				General	4		
Departures	Los Angeles, California (Practice)	LAX	HOLTZ NINE	6	Path-Specific	Altitude	1
						Distance	1
						Track	1
						Speed	1
						Notes	1
					General	1	
	Dallas-Fort Worth, Texas	DFW	DARTZ THREE	12	Path-Specific	Altitude	2
						Distance	2
						Track	2
						Speed	2
						Notes	2
					General	2	
	Las Vegas, Nevada	LAS	SHEAD SEVEN	16	Path-Specific	Altitude	2
						Distance	2
						Track	2
						Speed	2**
Notes						4	
General					4		
Salt Lake City, Utah	SLC	LEETZ TWO	16	Path-Specific	Altitude	4	
					Distance	2	
					Track	2	
					Speed	2	
					Notes	2	
				General	6		
Note: All questions are divided equally between modified and current charts							
*Two questions were not analyzed due to a spelling mistake							
**One track question is substituted for a speed question							

Appendix F: Experiment Materials Presented to the Participant

F1: Introduction to Study

Thank you for participating in the *Chart Format Study* conducted by Massachusetts Institute of Technology and the United States Department of Transportation Volpe Center

Participants in the study must be current and licensed instrument-rated pilots. We expect that you have some experience flying RNAV procedures, and it is also expected you are either qualified, or in training, to fly RNP procedures. If your flight experience does not meet these qualifications, please let the experimenter know at this time.

Overview

The experiment contains three sections:

1. Introduction to study
2. Information Retrieval Task
3. Post-Experiment Questionnaire

In the information retrieval task, you will answer some questions about the RNAV/RNP charts presented. Two types of chart formats will be presented in random order: one is what is currently used and the other is one we have modified. We will measure the time and accuracy with which you answer the questions.

Before beginning the experiment, the experimenter will give you a Consent Form and a Background Questionnaire.

At the end of the experiment, you will be given a post-experiment questionnaire to provide feedback on the experiment. The experiment is expected to take over an hour. You will get opportunities to take short breaks throughout the session.

Outcome

Results of this study will be considered by the FAA in developing guidance for the design of instrument procedures and associated charting.

This research is funded by the FAA Human Factors Research and Engineering Group (AJP-61) in support of Aviation Safety (AVS) and the Flight Technologies and Procedures Division (AFS-470).

F2: CONSENT TO PARTICIPATE IN NON-BIOMEDICAL RESEARCH

Evaluating Impact of Chart De-Cluttering by Separating Paths Across Multiple-Charts

You are invited to participate in a research study conducted by R. John Hansman, Abhizna Butchibabu, and Alan Midkiff, from the Department of Aeronautics and Astronautics at the Massachusetts Institute of Technology (M.I.T.) and Divya Chandra, Andrew Kendra, and Rebecca Grayhem from the John A. Volpe National Transportation Center, United States Department of Transportation. You should read the information below, and ask questions about anything you do not understand before deciding whether or not to participate.

· PARTICIPATION AND WITHDRAWAL

Your participation in this study is completely voluntary and you are free to choose whether to be in it or not. If you choose to be in this study, you may subsequently withdraw from it at any time without penalty or consequences of any kind.

· PURPOSE OF THE STUDY

The purpose of this study is to examine the design of instrument procedures and associated charting for Area Navigation (RNAV) and Required Navigation Procedures (RNP).

· PROCEDURES

You will be shown two types of charts: current and modified. You will use these charts to find information requested by the experimenter. Please answer the questions as quickly and as accurately as you can. We will be recording your time to find the requested information. You will see both departures approach procedures.

You will have a chance to practice answering chart questions before we start collecting data, and there will be rest breaks during the study.

The study will take approximately one hour to complete, with breaks. You will also be given an opportunity to provide feedback on the study. Please feel free to ask any questions during the practice trials or breaks.

· POTENTIAL RISKS AND DISCOMFORTS

The risks involved in your participation are low and do not exceed those you would experience in a normal flight training atmosphere.

· POTENTIAL BENEFITS

Participation provides an opportunity to aid in the development of recommendations for the design of instrument procedures and associated charting.

· CONFIDENTIALITY

Any information that is obtained in connection with this study and that can be identified with you will remain confidential and will be disclosed only with your permission or as required by law.

Your participation in this study is completely voluntary. Your participation is strictly confidential, and no individual names or identities will be recorded with any data or released in any reports. Only arbitrary numbers are used to identify pilots who provide data. You may terminate your participation in the study at any time.

· **IDENTIFICATION OF INVESTIGATORS**

If you have any questions or concerns about the research, please feel free to contact R. John Hansman at rjhans@mit.edu or call (617) 253-3371 or contact Abhizna Butchibabu at abhiznab@mit.edu or call (848) 219-7999.

· **EMERGENCY CARE AND COMPENSATION FOR INJURY**

If you feel you have suffered an injury, which may include emotional trauma, as a result of participating in this study, please contact the person in charge of the study as soon as possible.

In the event you suffer such an injury, M.I.T. may provide itself, or arrange for the provision of, emergency transport or medical treatment, including emergency treatment and follow-up care, as needed, or reimbursement for such medical services. M.I.T. does not provide any other form of compensation for injury. In any case, neither the offer to provide medical assistance, nor the actual provision of medical services shall be considered an admission of fault or acceptance of liability. Questions regarding this policy may be directed to MIT's Insurance Office, (617) 253-2823. Your insurance carrier may be billed for the cost of emergency transport or medical treatment, if such services are determined not to be directly related to your participation in this study

· **RIGHTS OF RESEARCH SUBJECTS**

You are not waiving any legal claims, rights or remedies because of your participation in this research study. If you feel you have been treated unfairly, or you have questions regarding your rights as a research subject, you may contact the Chairman of the Committee on the Use of Humans as Experimental Subjects, M.I.T., Room E25-143B, 77 Massachusetts Ave, Cambridge, MA 02139, phone (617) 253 6787.

SIGNATURE OF RESEARCH SUBJECT OR LEGAL REPRESENTATIVE

I understand the procedures described above. My questions have been answered to my satisfaction, and I agree to participate in this study. I have been given a copy of this form.

Name of Subject _____

Name of Legal Representative (if applicable)

Signature of Subject or Legal Representative

Date

SIGNATURE OF INVESTIGATOR

In my judgment the subject is voluntarily and knowingly giving informed consent and possesses the legal capacity to give informed consent to participate in this research study.

Signature of Investigator

Date

F3: Background Questionnaire

Participant ID _____

Flight Background

Total flight hours (approximate) _____

Are you a check airman or do you provide flight/simulator instruction for your company?

- Yes No

Which charts would you like to use for the experiment (pick one)?

- Jeppesen US Government

RNAV/RNP Experience

1. Are you currently qualified for RNP approaches?

- Yes No In Training

2. When was your last simulator training on RNP procedures?

- In Training Now
 Within 2 months
 2 to 6 months ago
 6 to 12 months ago
 12 or more months ago

3. When was the last time you flew an RNP procedure in line operations?

- Within 1 month
 Within 6 months
 6 to 12 months
 Over 12 months
 Never flew RNP procedures in line operations

4. a) How many SIDs did you fly in your last active month (as a flight crew)?

- 0 < 1 1 to 2 3 to 4 5 to 10 Over 10

b) How many RNAVSIDs did you fly in your last active month (as a flight crew)?

- 0 < 1 1 to 2 3 to 4 5 to 10 Over 10

Rate your comfort with RNAV SIDs (1 = low to 5 high) _____

5. a) How many STARs did you fly in your last active month (as a flight crew)?

- 0 < 1 1 to 2 3 to 4 5 or more

b) How many RNAV STARs did you fly in your last active month (as a flight crew)?

- 0 < 1 1 to 2 3 to 4 5 or more

Rate your comfort with RNAV STARs (1 = low to 5 high) _____

6. a) How many IAPs did you fly in your last active month (as a flight crew)?

- 0 < 1 1 to 2 3 to 4 5 or more

b) How many RNAV (RNP) IAPs do you fly per month on average (as a flight crew)?

- 0 < 1 1 to 2 3 to 4 5 or more

Rate your comfort with RNAV (RNP)IAPs (1 = low to 5 high) _____

7. What types of RNP approaches do you generally fly (check all that apply)?

- Simple (straight-in/overlay)
- Complex (with RF legs)
- Complex with Terrain (with RF legs & terrain critical)

F4: Instructions for Information Retrieval Task for US Government Charts

As mentioned earlier, you will use RNAV/RNP charts to answer questions. The task will use a computer display. You will view the chart and answer the questions regarding the chart presented. Try to answer the questions as quickly and as accurately as you can.

The task is divided into blocks of trials. One block will concern SIDs, and the other will concern IAPs. You will be allowed several short breaks throughout the two blocks. Before beginning the test trials, you will be given the opportunity to practice and ask questions.

The overall experiment stages are shown in the table below:

Block 1	Practice SID or IAP
	Break
	SID or IAP questions
	Break
	SID or IAP questions
Break	
Block 2	Practice IAP or SID
	Break
	IAP or SID questions
	Break
	IAP or SID questions

Practice Trials

There are a total of 6 practice trials per procedure type (SID or IAP) that will give you an opportunity to practice the task before your responses are recorded.

You will become familiar with the display interface during the practice trials. If you have any questions about the task or the interface, please ask them during the practice scenarios.

Information Retrieval Task

Please look at the image on the handout to see an example layout for trials regarding SIDs and IAPs.

Information Provided

In the top right corner there is a trial counter, which will keep track of your progress within the block.

The chart will be presented in the center of the screen. Below the chart you will receive a clearance that will provide you with some context to help you answer the question. The question will appear below the clearance.

Viewing the chart

You will view the presented chart(s) to find the answer to the question. Please note the buttons used to view the chart(s) for SIDs and IAPs in the image on the handout. Please click on these button(s) after you have understood the question. For each question, the time taken to view the chart will be recorded.

Answering the question

After you have found the answer from the chart, you will click on the 'ANSWER QUESTION' button to type the answer into the text box. At this point the chart will be no longer visible and the timer will stop. If you forget your answer and need to refer to the chart again, you may do so, but the timer will resume again. You will not be timed when you are typing your response.

When answering the questions, please do not enter the units. For example, if the answer is 4000 ft, please enter only "4000."

When you are ready to proceed to the next question, please click 'NEXT.'

You must answer each question before clicking 'NEXT.'

F5: Post-Experiment Questionnaire

Have you flown RNAV/RNP procedures at the following airports in the past year?

BOI SLC DFW LAS PSP BZN

Have you encountered any problems when flying the RNP procedures in your daily operations?

Feedback on the experiment

Yes No

- Were the questions you received reasonable?
- Were the charts used reasonable?
- Was the experiment display used understandable?

Do you have any suggestions for how to improve our experiment?

Please provide any additional comments regarding the experiment below.

Appendix G: FAA Chart Refresher for Jeppesen Chart Users Participating in the Experiment



FAA Chart Refresher

Part 1: Instrument Approach Procedures (IAP)

Part 2: Standard Instrument Departures (SID)



Part 1: Instrument Approach Procedures (IAP)



Procedure Titles and Airport Identification

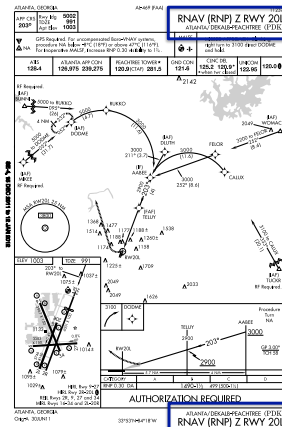
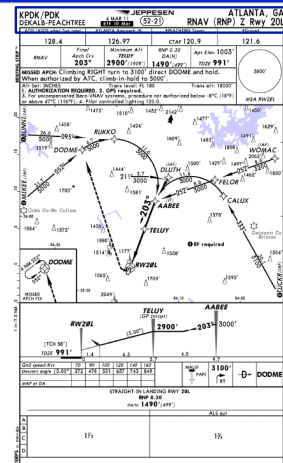

3



Briefing Strip

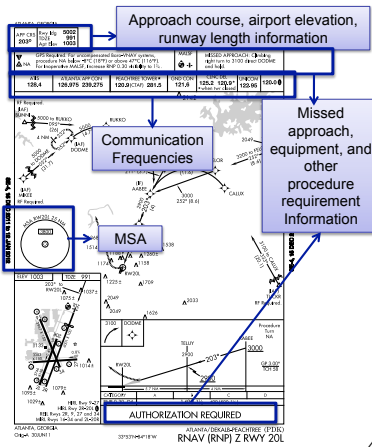
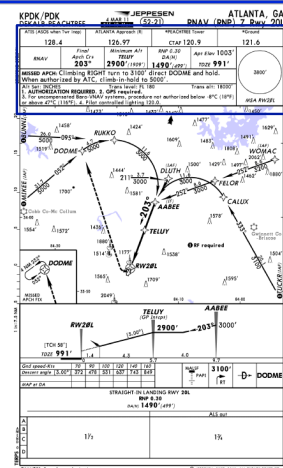

4



Altitude Constraints, Segment Distance, Heading and off-scale segments

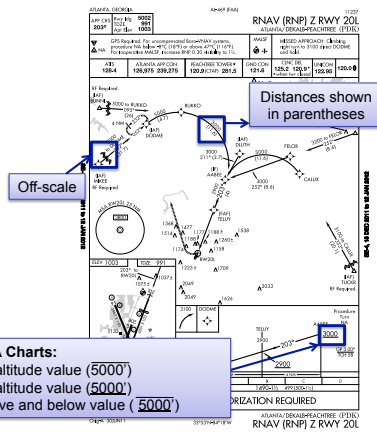
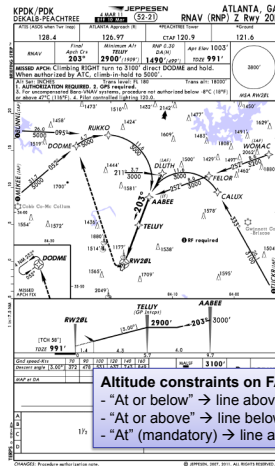

Notes

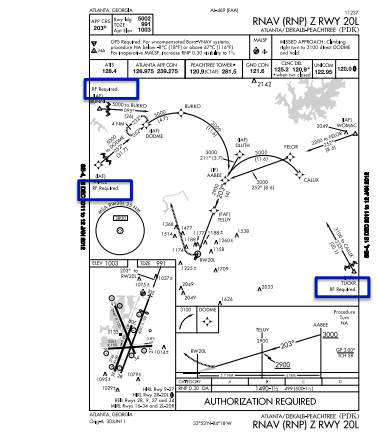
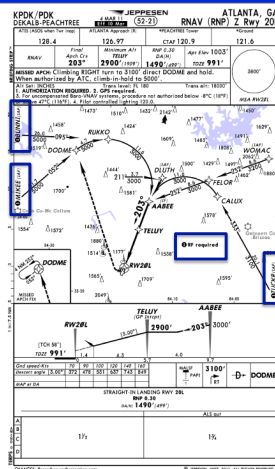



Missed Approach Icons

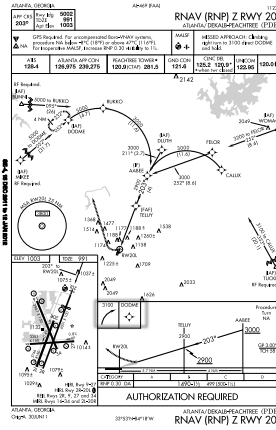
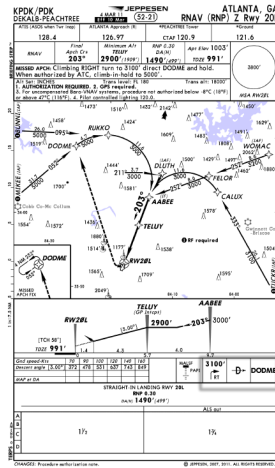

7



Decision Altitude and RVR

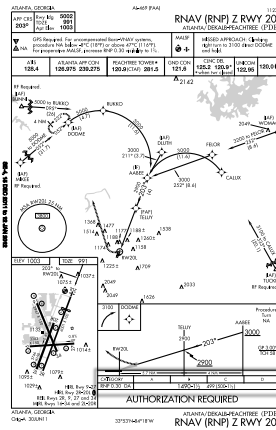
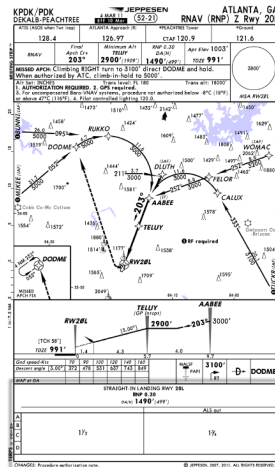

8



Airport Diagram

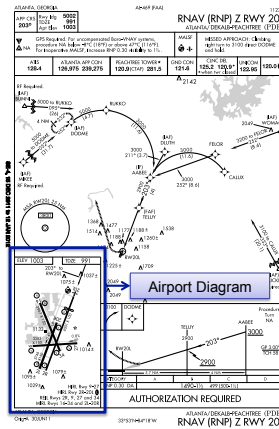
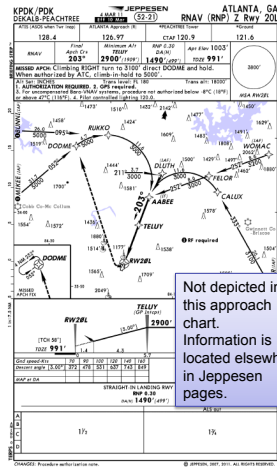

9



Part 2: Standard Instrument Departures (SID)



Number of Pages



FAA departure procedure charts may have 2 pages

Second page on FAA procedure charts typically shows text departure route description and obstacle notes

Jeppesen Charts

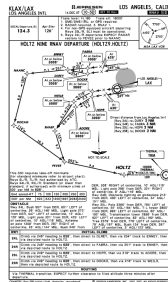

FAA Charts

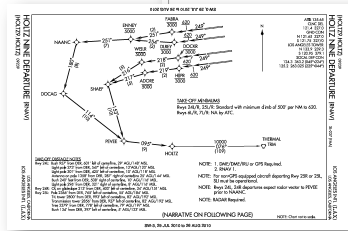

Procedure Titles and Airport Identification

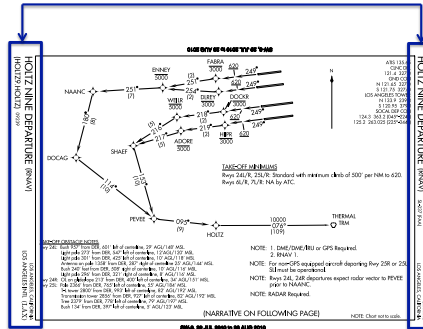
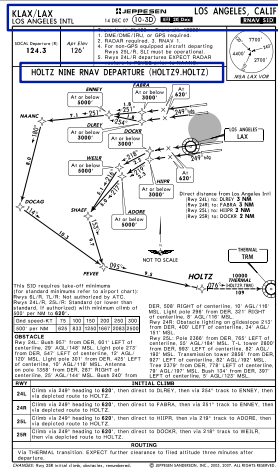



Briefing Strip Information MSA, Communication Frequencies, Equipment Notes

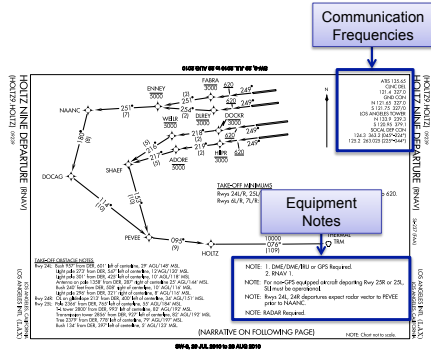
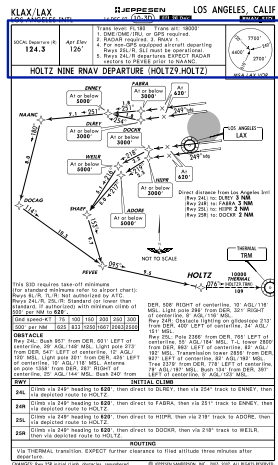

Take-off Minimums and Obstacle Notes speed and climb rate table, notes

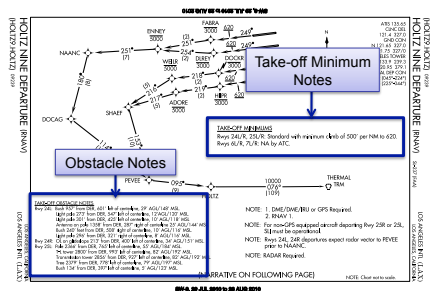
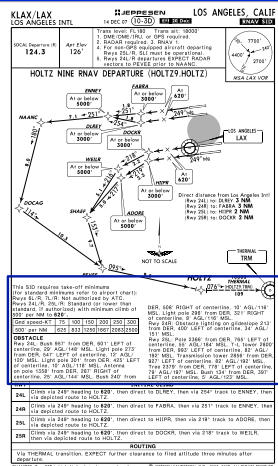



Initial Climb and Routing Notes

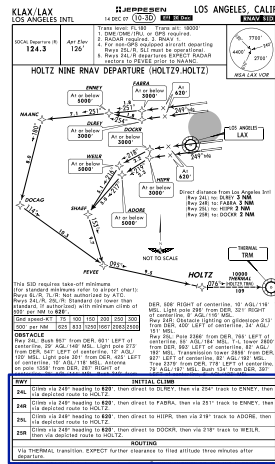

Second Page of the chart

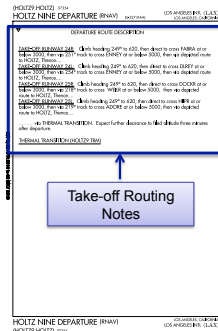

Altitude Constraints, Segment Distance and Heading

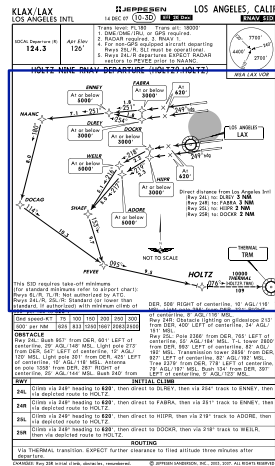

Altitude constraints on FAA Charts:

- "At or below" → line above altitude value (5000)
- "At or above" → line below altitude value (5000)
- "At" (mandatory) → line above and below value (5000)

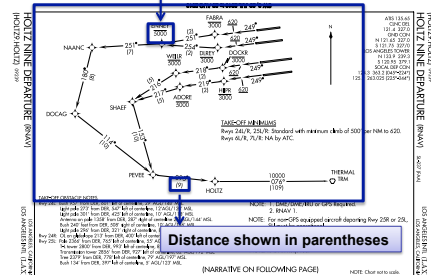



Direct Distance from Runway to Initial Fix

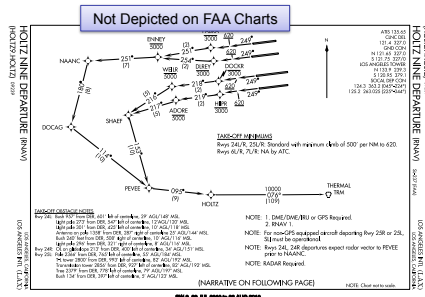
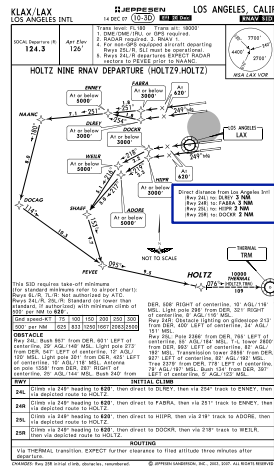

17



End of Refresher

Any questions?

Appendix G: Charts used for the Information Retrieval Task

G1: FAA Current Charts

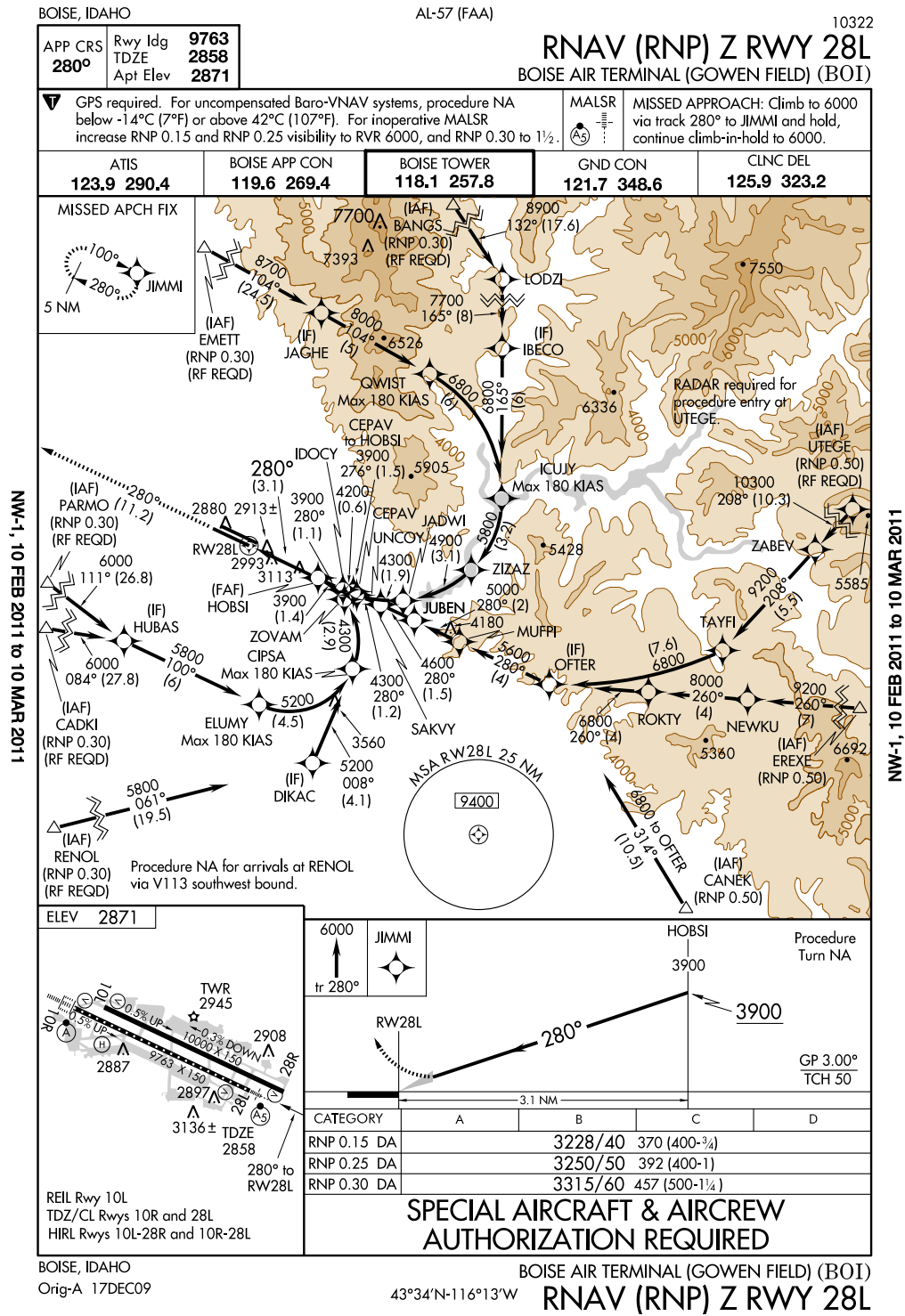

BOZEMAN, MONTANA

AL-59 (FAA)

11069

APP CRS 123°	Rwy Idg 8994
	TDZE 4443
	Apt Elev 4473

RNAV (RNP) Z RWY 12

BOZEMAN/GALLATIN FIELD (BZN)

GPS Required. For uncompensated Baro-VNAV systems, procedure NA below -23°C (-11°F) or above 39°C (102°F). When VGSi inop, procedure NA at night. For inoperative MALSr increase RNP 0.30 visibility to 1 1/4 all Cats.



MISSED APPROACH: Climb to 8300 via track 123° to HETSI, and via right turn to HAXAG, and via track 320° to THESE and hold.

ATIS 135.425	SALT LAKE CENTER 132.4 338.3	BOZEMAN TOWER ★ 118.2 (CTAF) 0	GND CON 121.8	UNICOM 122.95
------------------------	--	--	-------------------------	-------------------------

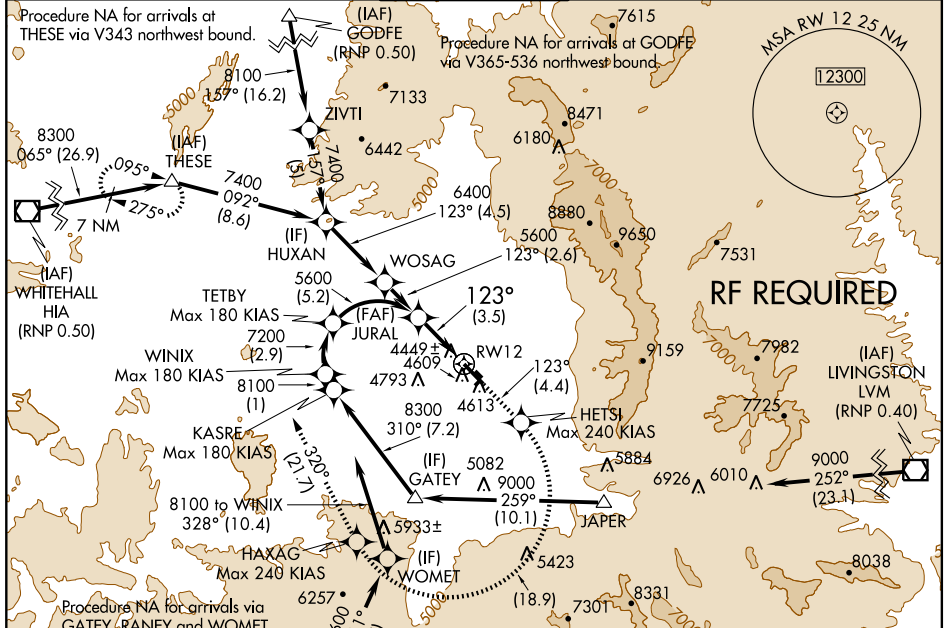

NW-1, 10 MAR 2011 to 07 APR 2011

NW-1, 10 MAR 2011 to 07 APR 2011

ELEV 4473	TDZE 4443
-----------	-----------

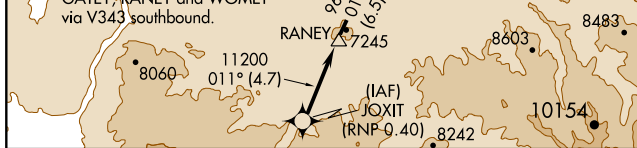

Procedure Turn NA	JURAL	8300	HETSI	HAXAG	THESE
		↑	✦	↶	△
		tr 123°		tr 320°	
					See planview for multiple IF locations.
		5600			
		GS 3.00°			
		TCH 53			

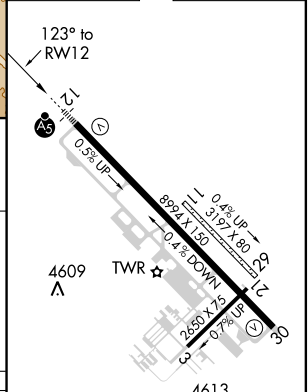

CATEGORY	A	B	C	D
RNP 0.30 DA		4791-1	348(400-1)	

SPECIAL AIRCRAFT & AIRCREW AUTHORIZATION REQUIRED

REIL Rwy 30 0
HIRL Rwy 12-30 0

BOZEMAN, MONTANA
Orig 29JUL10

BOZEMAN/GALLATIN FIELD (BZN)
RNAV (RNP) Z RWY 12

45°47'N-111°09'W

PALM SPRINGS, CALIFORNIA

AL-545 (FAA)

10210

APP CRS	Rwy Idg	8500
309°	TDZE	430
	Apt Elev	477

RNAV (RNP) Y RWY 31L

PALM SPRINGS INTL (PSP)

GPS required. Procedure NA when control tower closed.
NA For uncompensated Baro-VNAV systems, procedure NA below 2°C (35°F) or above 38°C (102°F).
 Missed approach requires minimum climb of 340' per NM to 3000.
 Visibility reduction by helicopters NA.

MISSED APPROACH: Climb to 1800, then climbing right turn to 4000 direct TRM VORTAC and hold.

ATIS	SOCAL APP CON*	PALM SPRINGS TOWER*	GND CON	CLNC DEL	UNICOM
118.25	126.7 370.95 (W-N) 135.275 251.1 (NE-SW)	119.7 (CTAF) 0 377.05	121.9	128.35	122.95

SW-3, 10 FEB 2011 to 10 MAR 2011

SW-3, 10 FEB 2011 to 10 MAR 2011

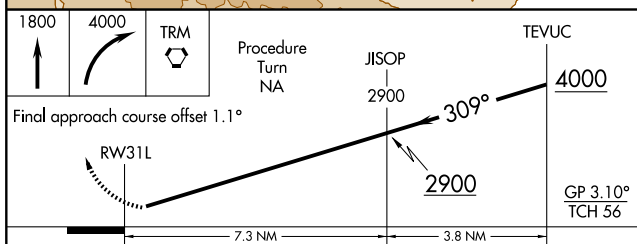
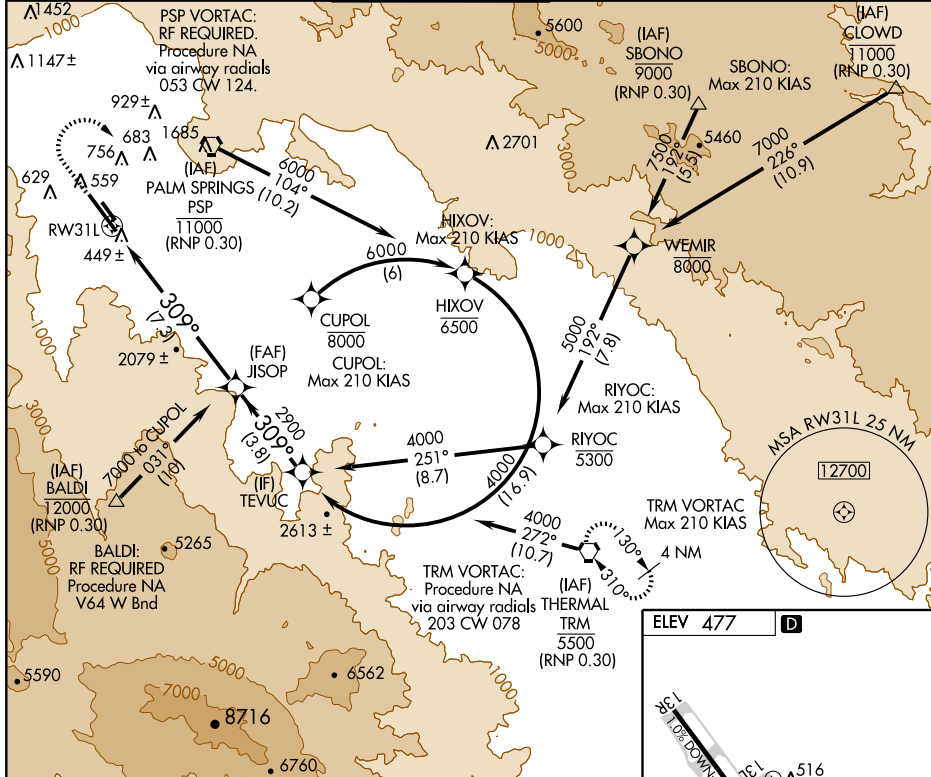

CATEGORY	A	B	C	D
RNP 0.30 DA		734-1	304 (300-1)	

SPECIAL AIRCRAFT & AIRCREW AUTHORIZATION REQUIRED

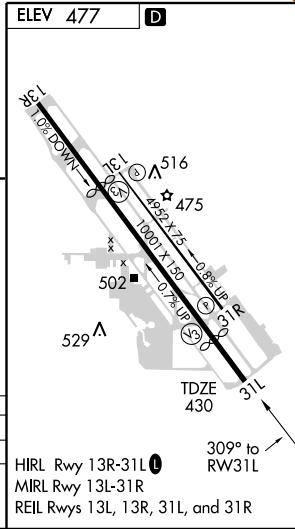

PALM SPRINGS, CALIFORNIA
 Amdt 1A 11MAR10

33°50'N-116°30'W

RNAV (RNP) Y RWY 31L

PALM SPRINGS INTL (PSP)

SW-4, 10 MAR 2011 to 07 APR 2011

LEETZ TWO DEPARTURE (RNAV)
(LEETZ2.LEETZ) 11069

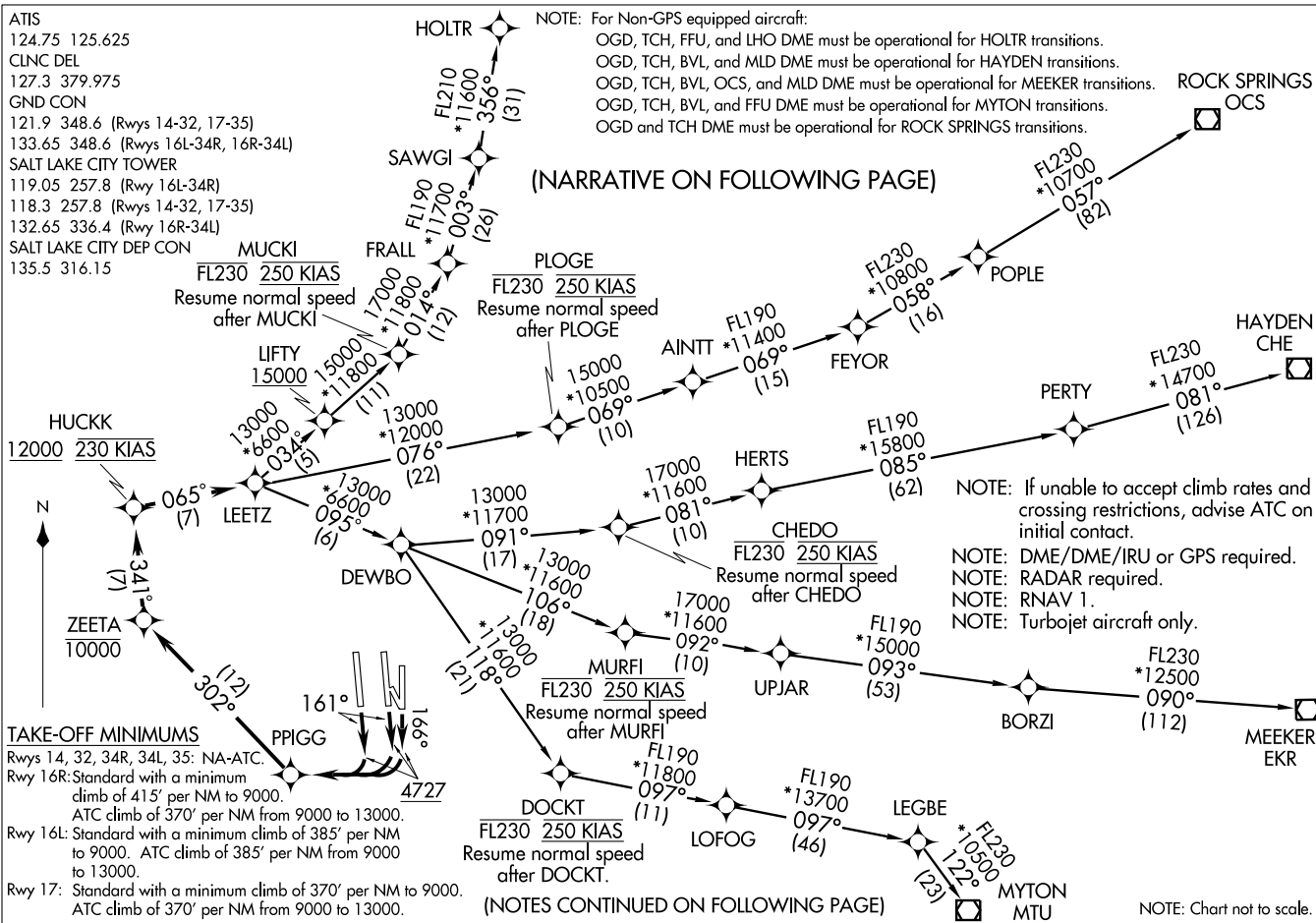

SW-4, 10 MAR 2011 to 07 APR 2011

(NARRATIVE ON FOLLOWING PAGE)

(NOTES CONTINUED ON FOLLOWING PAGE)

(LEETZ2.LEETZ) 08325

SL-365 (FAA)

SALT LAKE CITY INTL (SLC)
SALT LAKE CITY, UTAH

LEETZ TWO DEPARTURE (RNAV)



DEPARTURE ROUTE DESCRIPTION

TAKE-OFF RUNWAYS 16R/16L: Climb heading 161° to 4727, then right turn direct PPIGG, then via depicted route to LEETZ, thence....

TAKE-OFF RUNWAY 17: Climb heading 166° to 4727, then right turn direct PPIGG, then via depicted route to LEETZ, thence....

....via (transition) maintain FL230 or lower filed altitude. Expect filed altitude 10 minutes after departure.

HAYDEN TRANSITION (LEETZ2.CHE)

HOLTR TRANSITION (LEETZ2.HOLTR)

MEEKER TRANSITION (LEETZ2.EKR)

MYTON TRANSITION (LEETZ2.MTU)

ROCK SPRINGS TRANSITION (LEETZ2.OCS)

TAKE-OFF NOTES CONT.

TAKE-OFF OBSTACLES

Rwy 16L, 16R, and 17: Multiple light poles beginning 988' from DER, 689' right of centerline, up to 34' AGL/4254' MSL.

Rwy 17: Vehicle on road 434' from DER, 518' right of centerline, 17' AGL/4237' MSL.

SW-4, 10 FEB 2011 to 10 MAR 2011

SW-4, 10 FEB 2011 to 10 MAR 2011

LEETZ TWO DEPARTURE (RNAV)
(LEETZ2.LEETZ) 08325

SALT LAKE CITY, UTAH
SALT LAKE CITY INTL (SLC)

(DARTZ3.DARTZ) 10098

DARTZ THREE DEPARTURE (RNAV)

DALLAS FORT WORTH INTL (DFW)
SL-6039 (FAA) DALLAS-FORT WORTH, TEXAS

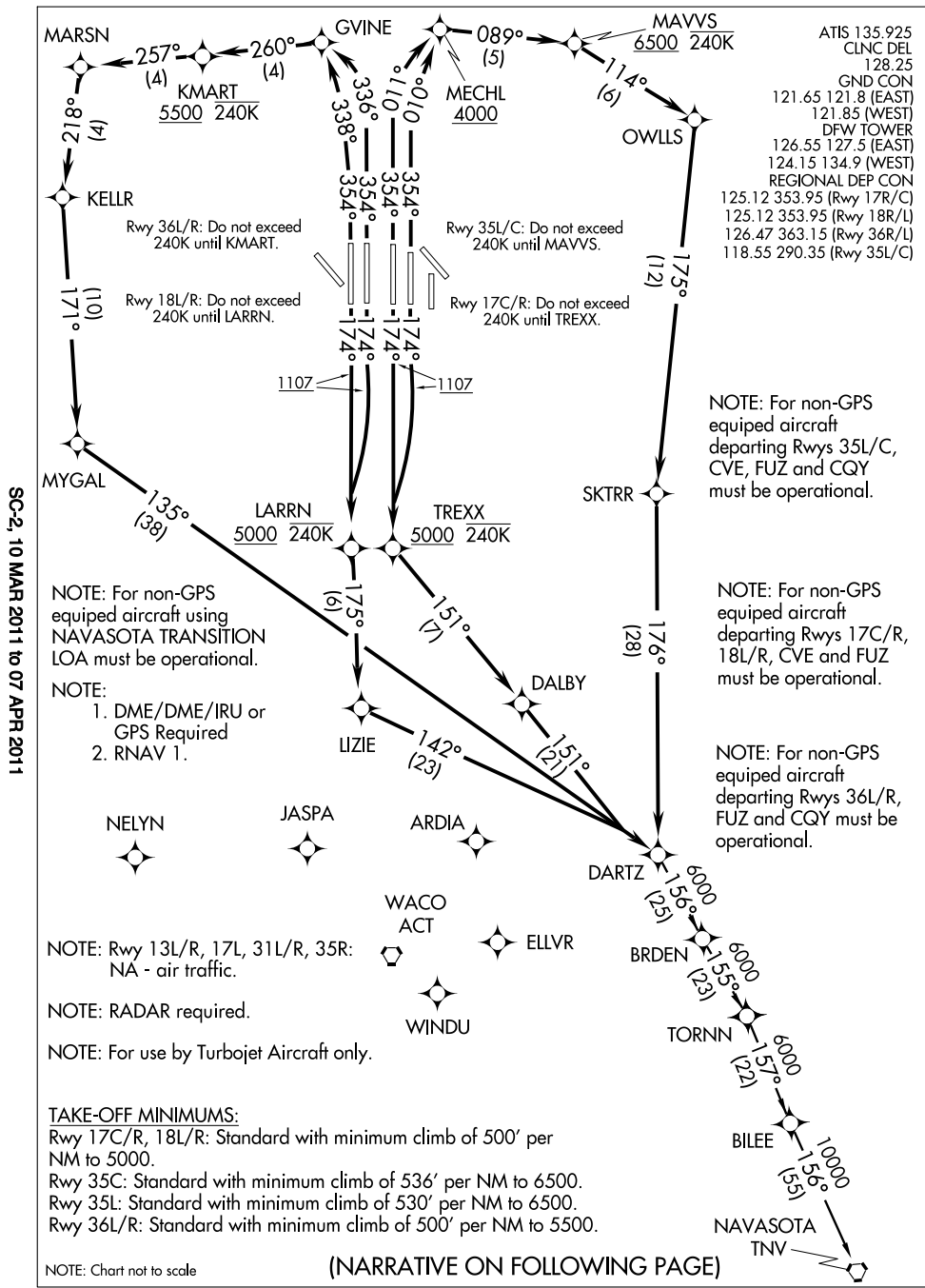

SC-2, 10 MAR 2011 to 07 APR 2011

SC-2, 10 MAR 2011 to 07 APR 2011

DARTZ THREE DEPARTURE (RNAV)
(DARTZ3.DARTZ) 10098

DALLAS-FORT WORTH, TEXAS
DALLAS FORT WORTH INTL (DFW)



DEPARTURE ROUTE DESCRIPTION

TAKE-OFF RUNWAY 17C: Climb heading 174° to 1107, then direct TREXX, cross TREXX at or above 5000, then on depicted route to DARTZ, Thence

TAKE-OFF RUNWAY 17R: Climb heading 174° to 1107, then direct TREXX, cross TREXX at or above 5000, then on depicted route to DARTZ, Thence

TAKE-OFF RUNWAY 18L: Climb heading 174° to 1107, then direct LARRN, cross LARRN at or above 5000, then on depicted route to DARTZ, Thence

TAKE-OFF RUNWAY 18R: Climb heading 174° to 1107, then direct LARRN, cross LARRN at or above 5000, then on depicted route to DARTZ, Thence

TAKE-OFF RUNWAY 35C: Climb heading 354° to intercept course 010° to MECHL, cross MECHL at or above 4000, then on track 089° to MAVVS, cross MAVVS at or above 6500, then on depicted route to DARTZ, Thence

TAKE-OFF RUNWAY 35L: Climb heading 354° to intercept course 011° to MECHL, cross MECHL at or above 4000, then on track 089° to MAVVS, cross MAVVS at or above 6500, then via depicted route to DARTZ, Thence

TAKE-OFF RUNWAY 36L: Climb heading 354° to intercept course 338° to GVINE, then on track 260° to KMART, cross KMART at or above 5500, then on depicted route to DARTZ, Thence

TAKE-OFF RUNWAY 36R: Climb heading 354° to intercept course 336° to GVINE, then on track 260° to KMART, cross KMART at or above 5500, then on depicted route to DARTZ, Thence

. via (transition). Maintain 10,000. Expect filed altitude within 10 minutes after departure.

TORNN TRANSITION (DARTZ3.TORNN): (For aircraft landing Lafayette, Lake Charles or Beaumont/Port Arthur airports)

BILEE TRANSITION (DARTZ3.BILEE): (For aircraft overflying the Bilee intersection, thence on the appropriate STAR to George Bush Intercontinental or Eastern Houston terminal airports.)

NAVASOTA TRANSITION (DARTZ3.TNV)

SC-2, 10 MAR 2011 to 07 APR 2011

SC-2, 10 MAR 2011 to 07 APR 2011

(SHEAD7.SHEAD) 11013

SHEAD SEVEN DEPARTURE (RNAV) SL-662 (FAA)

LAS VEGAS / MC CARRAN INTL (LAS)
LAS VEGAS, NEVADA

SW-4, 10 MAR 2011 to 07 APR 2011

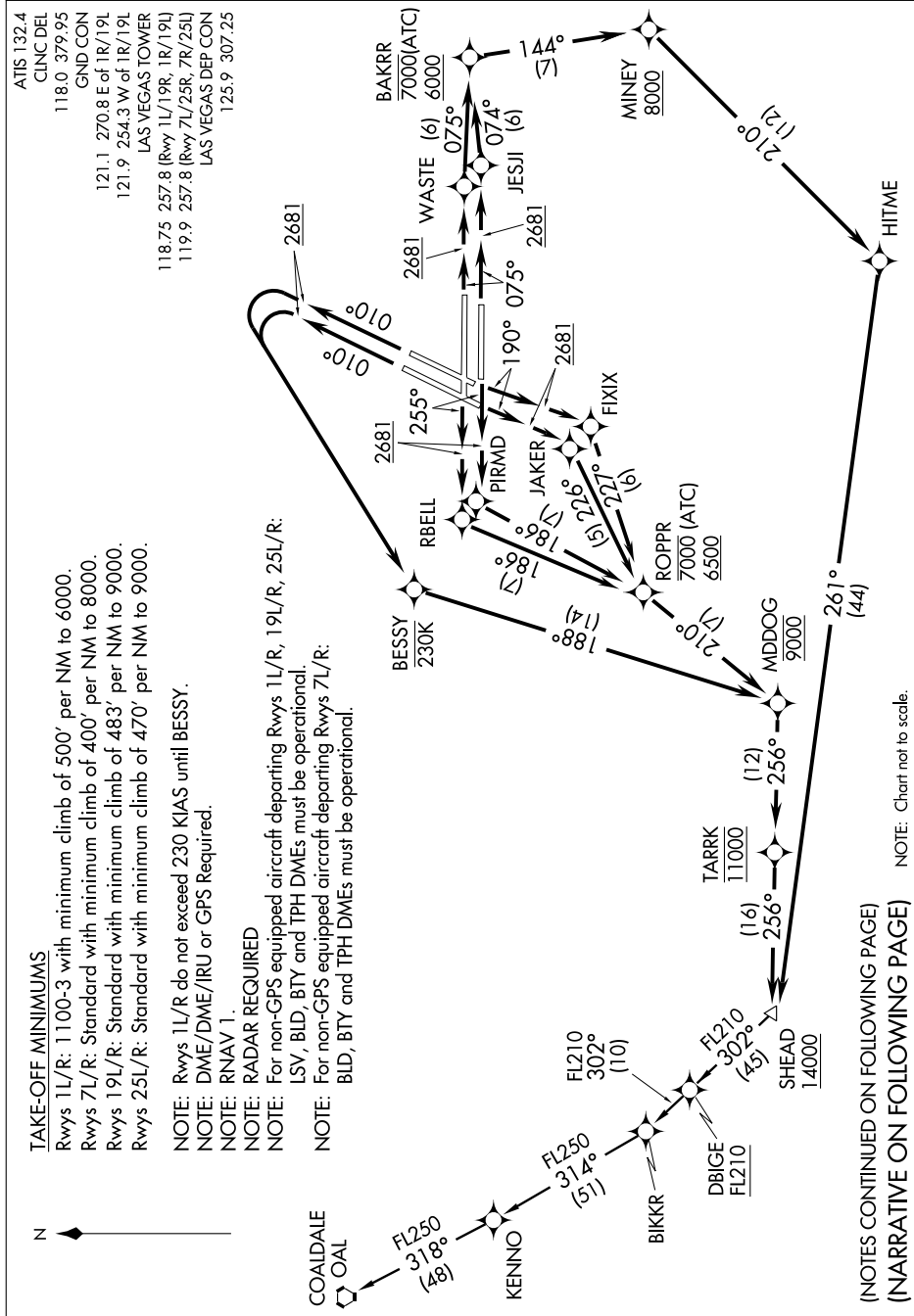

SHEAD SEVEN DEPARTURE (RNAV)
(SHEAD7.SHEAD) 11013

LAS VEGAS, NEVADA
LAS VEGAS / MC CARRAN INTL (LAS)

SW-4, 10 MAR 2011 to 07 APR 2011

(SHEAD7.SHEAD) 11013

SHEAD SEVEN DEPARTURE (RNAV) SL-662 (FAA)

LAS VEGAS / MC CARRAN INTL (LAS)
LAS VEGAS, NEVADA

DEPARTURE ROUTE DESCRIPTION

TAKE-OFF RUNWAY 1L/R: Climb heading 010° to 2681', then left turn direct BESSY, then on track 188° to cross MDDOG at 9000, then on track 256° to cross TARRK at 11000, then on track 256° to cross SHEAD at or above 14000. Thence....

TAKE-OFF RUNWAY 7L: Climb heading 075° to 2681', then direct WASTE, then on track 075° to cross BAKRR at or below 7000(ATC)/6000, then on track 144° to cross MINEY at or above 8000, then on track 210° to HITME, then on track 261° to cross SHEAD at or above 14000. Thence....

TAKE-OFF RUNWAY 7R: Climb heading 075° to 2681', then direct JESJI, then on track 074° to cross BAKRR at or below 7000(ATC)/6000, then on track 144° to cross MINEY at or above 8000, then on track 210° to HITME, then on track 261° to cross SHEAD at or above 14000. Thence....

TAKE-OFF RUNWAY 19L: Climb heading 190° to 2681', then direct FIXIX, then on track 227° to cross ROPPR at or below 7000(ATC)/6500, then on track 210° to cross MDDOG at 9000, then on track 256° to cross TARRK at 11000, then on track 256° to cross SHEAD at or above 14000. Thence....

TAKE-OFF RUNWAY 19R: Climb heading 190° to 2681', then direct JAKER, then on track 226° to cross ROPPR at or below 7000(ATC)/6500, then on track 210° to cross MDDOG at 9000, then on track 256° to cross TARRK at 11000, then on track 256° to cross SHEAD at or above 14000. Thence....

TAKE-OFF RUNWAY 25L: Climb heading 255° to 2681', then direct PIRMD, then on track 186° to cross ROPPR at or below 7000(ATC)/6500, then on track 210° to cross MDDOG at 9000, then on track 256° to cross TARRK at 11000, then on track 256° to cross SHEAD at or above 14000. Thence....

TAKE-OFF RUNWAY 25R: Climb heading 255° to 2681', then direct RBELL, then on track 186° to cross ROPPR at or below 7000(ATC)/6500, then on track 210° to cross MDDOG at 9000, then on track 256° to cross TARRK at 11000, then on track 256° to cross SHEAD at or above 14000. Thence....

....via (Transition) maintain FL190, expect filed altitude 10 minutes after departure.

COALDALE TRANSITION (SHEAD7.OAL)

KENNO TRANSITION (SHEAD7.KENNO)

TAKE-OFF OBSTACLE NOTES

RWY 1L: Building 1508' from DER, 463' left of centerline, 71' AGL/2146' MSL. Pole 453' from DER, 283' left of centerline, 38' AGL/2118' MSL. Sign 1042' from DER, 694' left of centerline, 35' AGL/2124' MSL.

RWY 1R: Sign 1331' from DER, 448' right of centerline, 60' AGL/2120' MSL. Vents 604' from DER, 539' right of centerline, up to 17' AGL/2095' MSL.

RWY 7L: Trees 761' from DER, left and right of centerline, up to 42' AGL/2074' MSL. Pole 747' from DER, 442' right of centerline, 25' AGL/2057' MSL.

RWY 7R: Tower 1457' from DER, 847' right of centerline, 65' AGL/2096' MSL.

RWY 19L: Multiple buildings, trees and poles 1394' from DER, 251' right of centerline, up to 96' AGL/2284' MSL. Sign 2181' from DER, 1062' right of centerline, 36' AGL/2236' MSL.

RWY 19R: Trees 1563' from DER, 329' left of centerline, up to 55' AGL/2236' MSL. Multiple buildings, signs and poles 197' from DER, 59' right of centerline, up to 75' AGL/2291' MSL.

RWY 25L: Multiple poles, signs and buildings 1003' from DER, 145' left of centerline, up to 97' AGL/2291' MSL. Trees 2837' from DER, 1008' left of centerline, 72' AGL/2230' MSL. Railroad 2564' from DER, 773' left of centerline, 66' AGL/2223' MSL.

RWY 25R: Multiple poles and trees 533' from DER, 1' left of centerline, up to 271' AGL/2457' MSL. Building 1822' from DER, 652' left of centerline, 59' AGL/2238' MSL. Roads 669' from DER, 17' right of centerline, up to 29' AGL/2208' MSL.

SW-4, 10 MAR 2011 to 07 APR 2011

SW-4, 10 MAR 2011 to 07 APR 2011

SHEAD SEVEN DEPARTURE (RNAV)
(SHEAD7.SHEAD) 11013

LAS VEGAS, NEVADA
LAS VEGAS / MC CARRAN INTL (LAS)

G2: FAA Modified Charts

BOI RNAV (RNP) Z RWY 28L (Page 1)

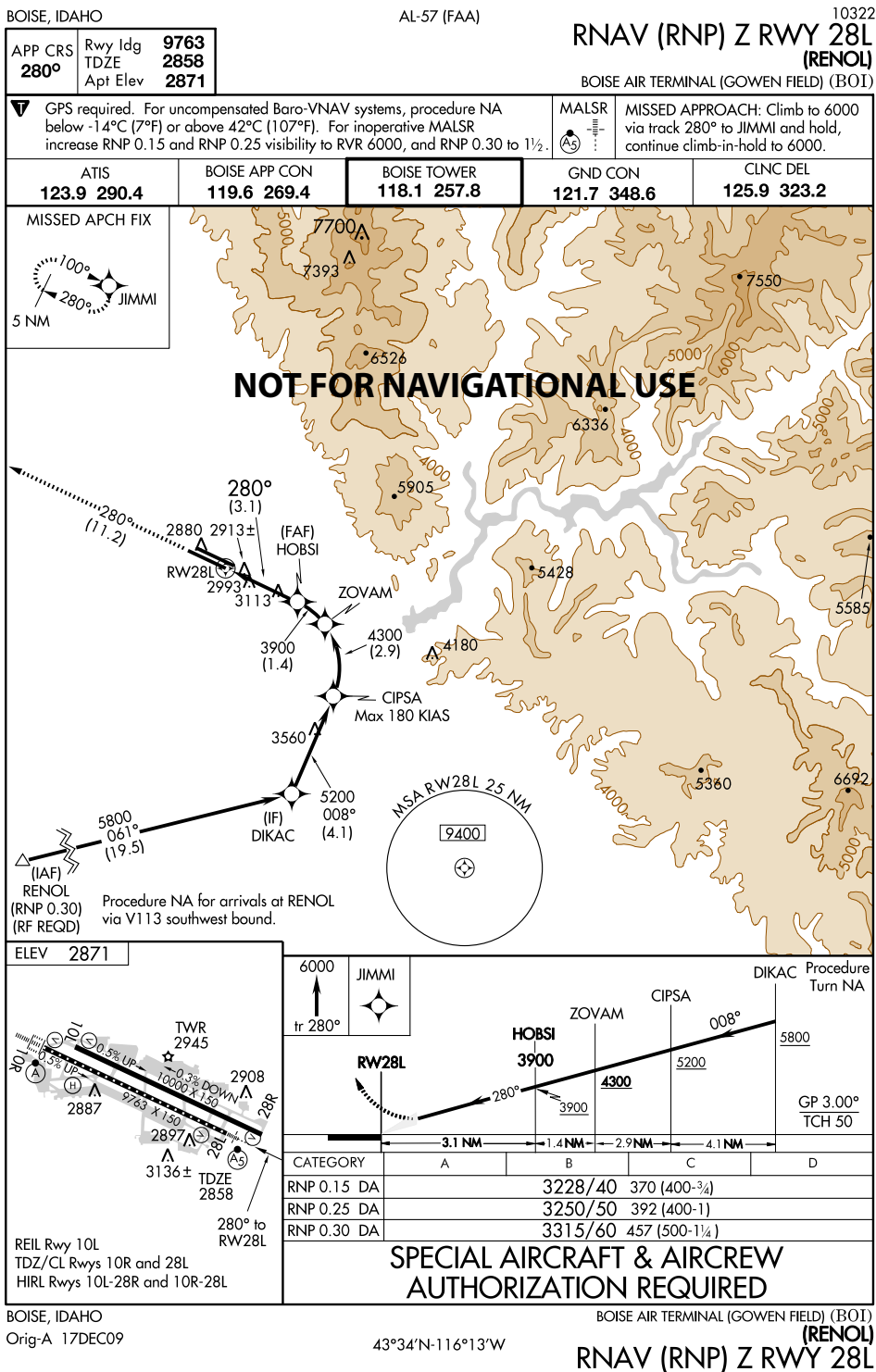

BOI RNAV (RNP) Z RWY 28L (Page 2)

BOISE, IDAHO

AL-57 (FAA)

10322

APP CRS 280°	Rwy Idg 9763
	TDZE 2858
	Apt Elev 2871

RNAV (RNP) Z RWY 28L
(CANEK/EREXE/UTEGE)

BOISE AIR TERMINAL (GOWEN FIELD) (BOI)

GPS required. For uncompensated Baro-VNAV systems, procedure NA below -14°C (7°F) or above 42°C (107°F). For inoperative MALSR increase RNP 0.15 and RNP 0.25 visibility to RVR 6000, and RNP 0.30 to 1½.

MALSR MISSED APPROACH: Climb to 6000 via track 280° to JIMMI and hold, continue climb-in-hold to 6000.

ATIS 123.9 290.4	BOISE APP CON 119.6 269.4	BOISE TOWER 118.1 257.8	GND CON 121.7 348.6	CLNC DEL 125.9 323.2
----------------------------	-------------------------------------	-----------------------------------	-------------------------------	--------------------------------

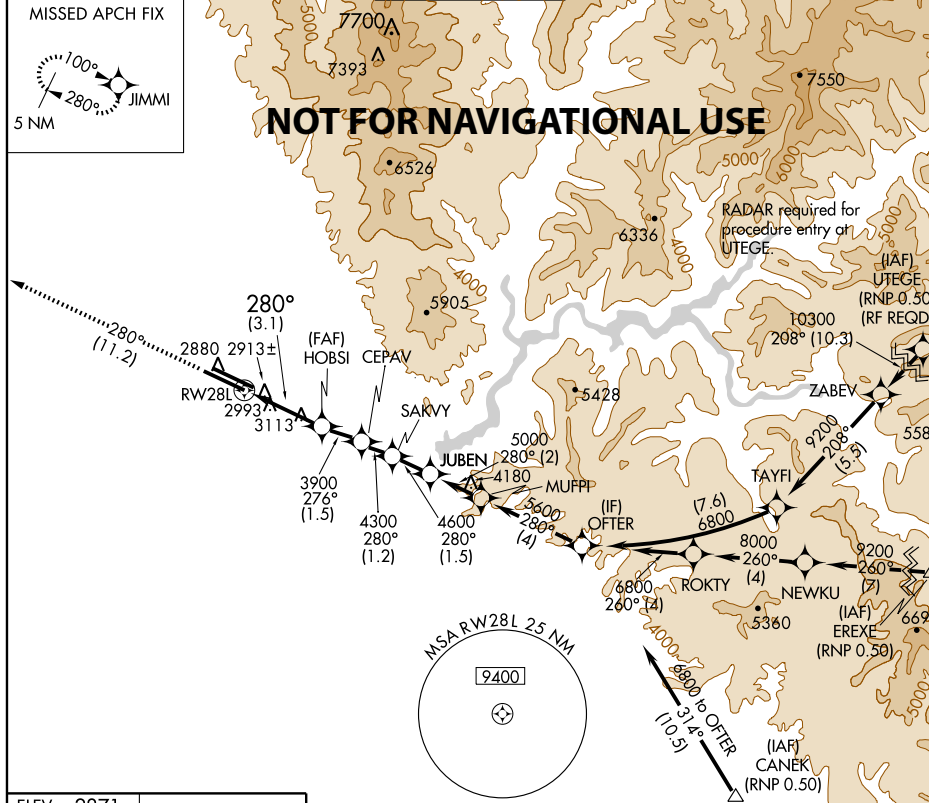

NW-1, 10 MAR 2011 to 07 APR 2011

NW-1, 10 MAR 2011 to 07 APR 2011

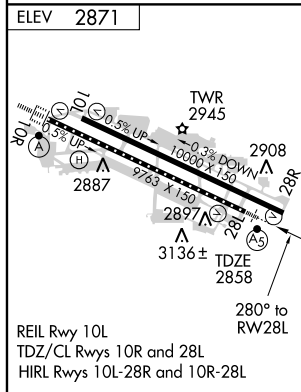

REIL Rwy 10L
TDZ/CL Rwys 10R and 28L
HIRL Rwys 10L-28R and 10R-28L

ELEV 2871	6000	JIMMI	Procedure Turn NA
tr 280°	↑	✦	
RW28L	HOBSI 3900	CEPAV	SAKVY
	JUBEN 5000	MUFP	OFFER 6800
	3.1 NM	1.5 NM	1.2 NM
		1.5 NM	2 NM
			4 NM
CATEGORY	A	B	C
RNP 0.15 DA		3228/40	370 (400-¾)
RNP 0.25 DA		3250/50	392 (400-1)
RNP 0.30 DA		3315/60	457 (500-1½)
SPECIAL AIRCRAFT & AIRCREW AUTHORIZATION REQUIRED			

BOISE, IDAHO
Orig-A 17DEC09

43°34'N-116°13'W

BOISE AIR TERMINAL (GOWEN FIELD) (BOI)
(CANEK/EREXE/UTEGE)
RNAV (RNP) Z RWY 28L

BOI RNAV (RNP) Z RWY 28L (Page 3)

BOISE, IDAHO

AL-57 (FAA)

10322

APP CRS	Rwy Idg	9763
280°	TDZE	2858
	Apt Elev	2871

RNAV (RNP) Z RWY 28L
(CADKI/PARMO)

BOISE AIR TERMINAL (GOWEN FIELD) (BOI)

GPS required. For uncompensated Baro-VNAV systems, procedure NA below -14°C (7°F) or above 42°C (107°F). For inoperative MALSRS increase RNP 0.15 and RNP 0.25 visibility to RVR 6000, and RNP 0.30 to 1½.

MALSRS MISSED APPROACH: Climb to 6000 via track 280° to JIMMI and hold, continue climb-in-hold to 6000.

ATIS	BOISE APP CON	BOISE TOWER	GND CON	CLNC DEL
123.9 290.4	119.6 269.4	118.1 257.8	121.7 348.6	125.9 323.2

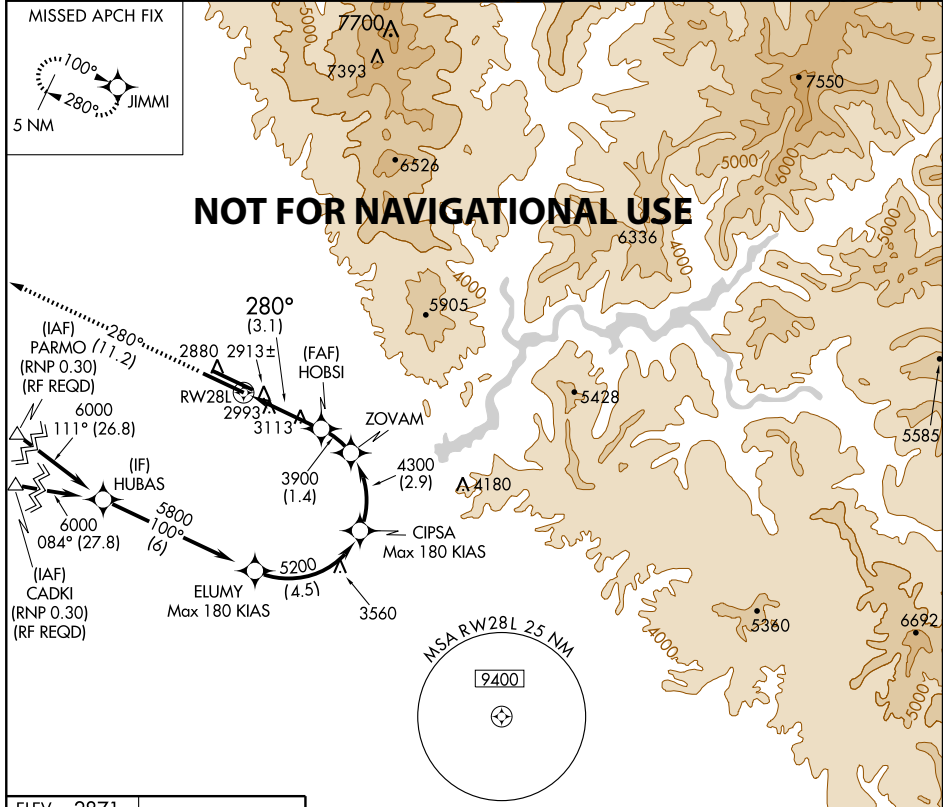

NW-1, 10 MAR 2011 to 07 APR 2011

NW-1, 10 MAR 2011 to 07 APR 2011

ELEV 2871

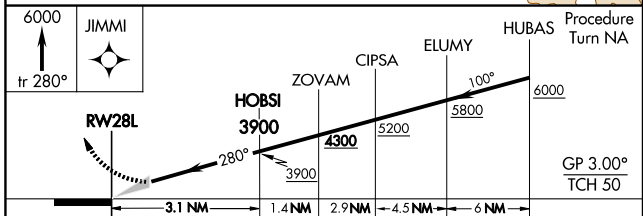
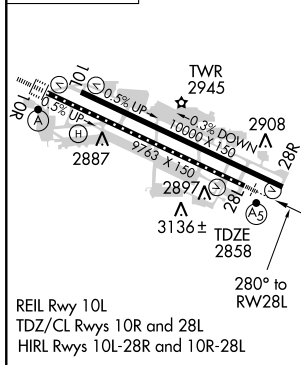

CATEGORY	A	B	C	D
RNP 0.15 DA		3228/40	370 (400-¾)	
RNP 0.25 DA		3250/50	392 (400-1)	
RNP 0.30 DA		3315/60	457 (500-1¼)	

**SPECIAL AIRCRAFT & AIRCREW
AUTHORIZATION REQUIRED**

BOISE, IDAHO
Orig-A 17DEC09

43°34'N-116°13'W

BOISE AIR TERMINAL (GOWEN FIELD) (BOI)
(CADKI/PARMO)
RNAV (RNP) Z RWY 28L

BOI RNAV (RNP) Z RWY 28L (Page 4)

BOISE, IDAHO AL-57 (FAA) 10322
RNAV (RNP) Z RWY 28L
(BANGS/EMETT)
 BOISE AIR TERMINAL (GOWEN FIELD) (BOI)

GPS required. For uncompensated Baro-VNAV systems, procedure NA below -1.4°C (7°F) or above 42°C (107°F). For inoperative MALSR increase RNP 0.15 and RNP 0.25 visibility to RVR 6000, and RNP 0.30 to 1½. MALSR MISSED APPROACH: Climb to 6000 via track 280° to JIMMI and hold, continue climb-in-hold to 6000.

ATIS 123.9 290.4	BOISE APP CON 119.6 269.4	BOISE TOWER 118.1 257.8	GND CON 121.7 348.6	CLNC DEL 125.9 323.2
----------------------------	-------------------------------------	-----------------------------------	-------------------------------	--------------------------------

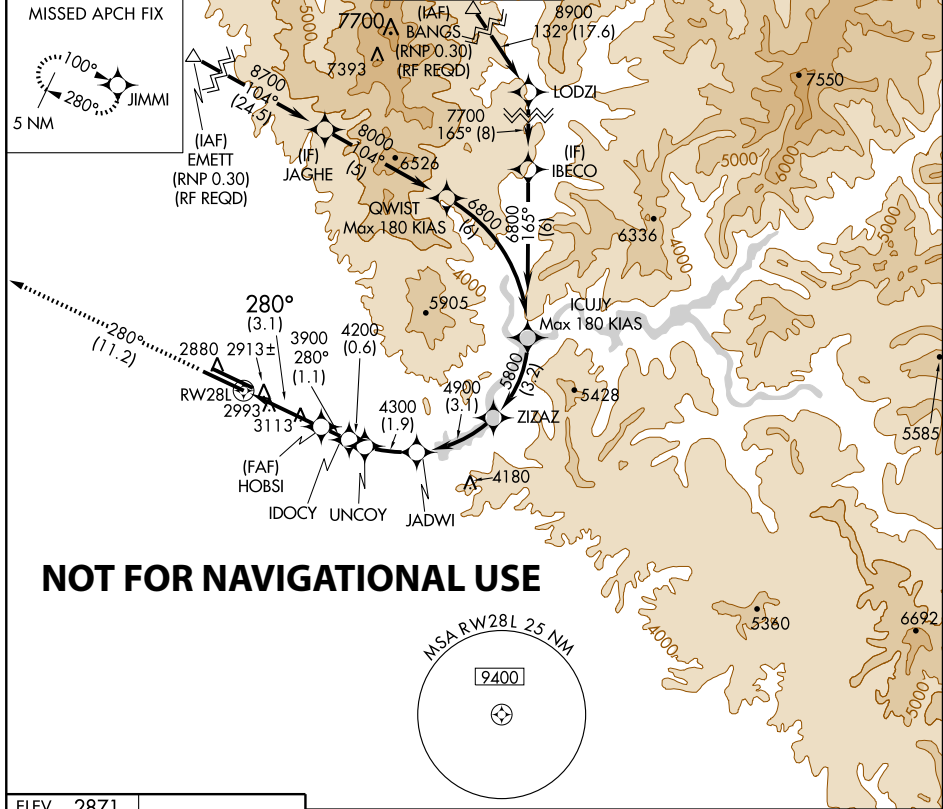

NW-1, 10 MAR 2011 to 07 APR 2011

NW-1, 10 MAR 2011 to 07 APR 2011

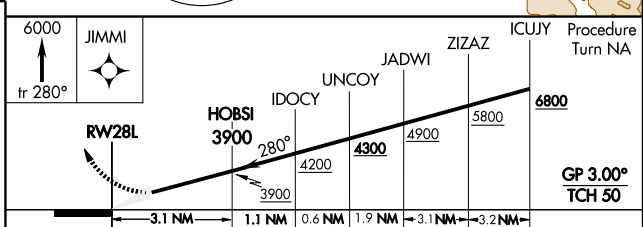
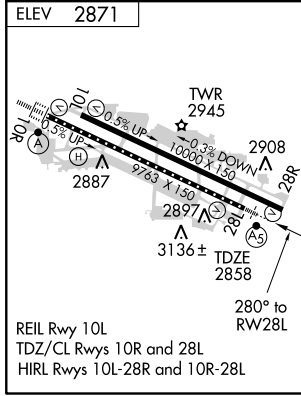

CATEGORY	A	B	C	D
RNP 0.15 DA		3228/40	370 (400-¾)	
RNP 0.25 DA		3250/50	392 (400-1)	
RNP 0.30 DA		3315/60	457 (500-1¼)	

**SPECIAL AIRCRAFT & AIRCREW
 AUTHORIZATION REQUIRED**

BOISE, IDAHO BOISE AIR TERMINAL (GOWEN FIELD) (BOI)
 Orig-A 17DEC09 43°34'N-116°13'W **RNAV (RNP) Z RWY 28L**
(BANGS/EMETT)

BZN RNAV (RNP) Z RWY 12 (Page 1)

BOZEMAN, MONTANA

AL-59 (FAA)

11069

APP CRS 123°	Rwy Idg 8994
	TDZE 4443
	Apt Elev 4473

**RNAV (RNP) Z RWY 12
(LIVINGSTON)**

BOZEMAN/GALLATIN FIELD (BZN)

GPS Required. For uncompensated Baro-VNAV systems, procedure NA below -23°C (-11°F) or above 39°C (102°F). When VGSI inop, procedure NA at night. For inoperative MALSR increase RNP 0.30 visibility to 1/4 all Cats.



MISSED APPROACH: Climb to 8300 via track 123° to HETSI, and via right turn to HAXAG, and via track 320° to THESE and hold.

ATIS 135.425	SALT LAKE CENTER 132.4 338.3	BOZEMAN TOWER ★ 118.2 (CTAF) 0	GND CON 121.8	UNICOM 122.95
------------------------	--	--	-------------------------	-------------------------

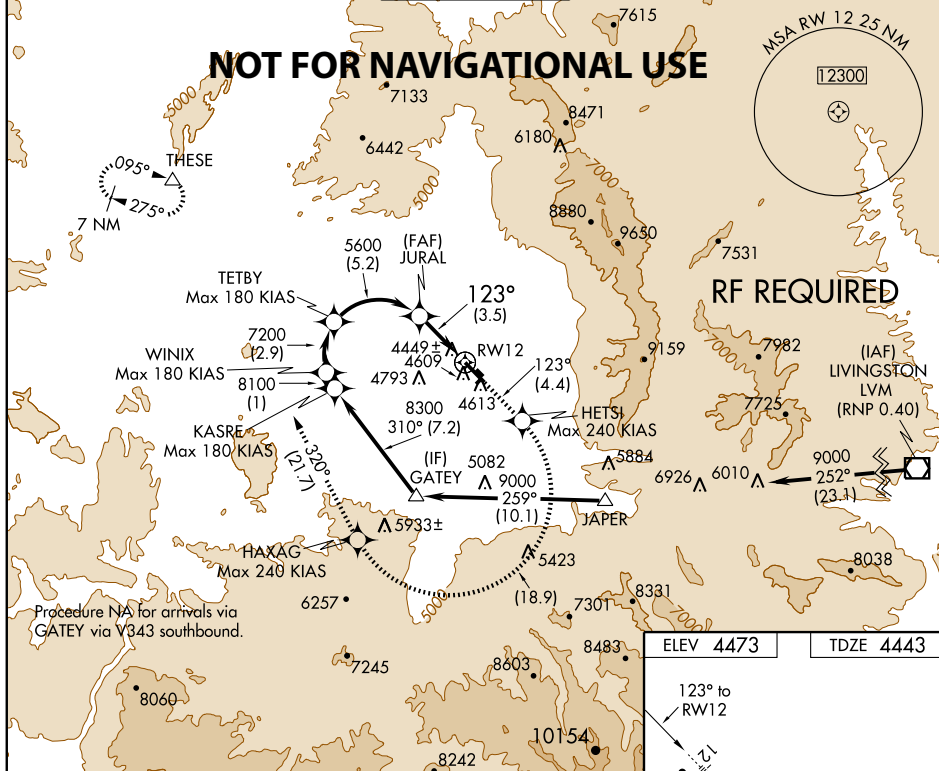

NW-1, 10 MAR 2011 to 07 APR 2011

NW-1, 10 MAR 2011 to 07 APR 2011

Procedure Turn NA	8300	HETSI	HAXAG	THESE
	↑	tr 123°	↪	tr 320°

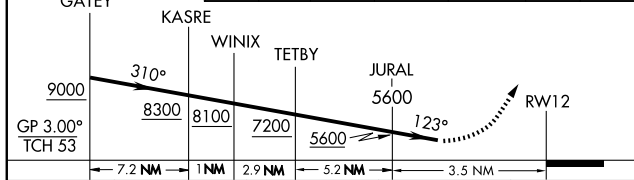

CATEGORY	A	B	C	D
RNP 0.30 DA	4791-1 348(400-1)			

**SPECIAL AIRCRAFT & AIRCREW
AUTHORIZATION REQUIRED**

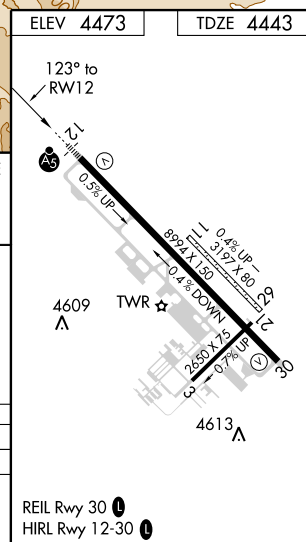

BOZEMAN, MONTANA

Orig 29JUL10

45°47'N-111°09'W

BOZEMAN/GALLATIN FIELD (BZN)

**RNAV (RNP) Z RWY 12
(LIVINGSTON)**

BZN RNAV (RNP) Z RWY 12 (Page 2)

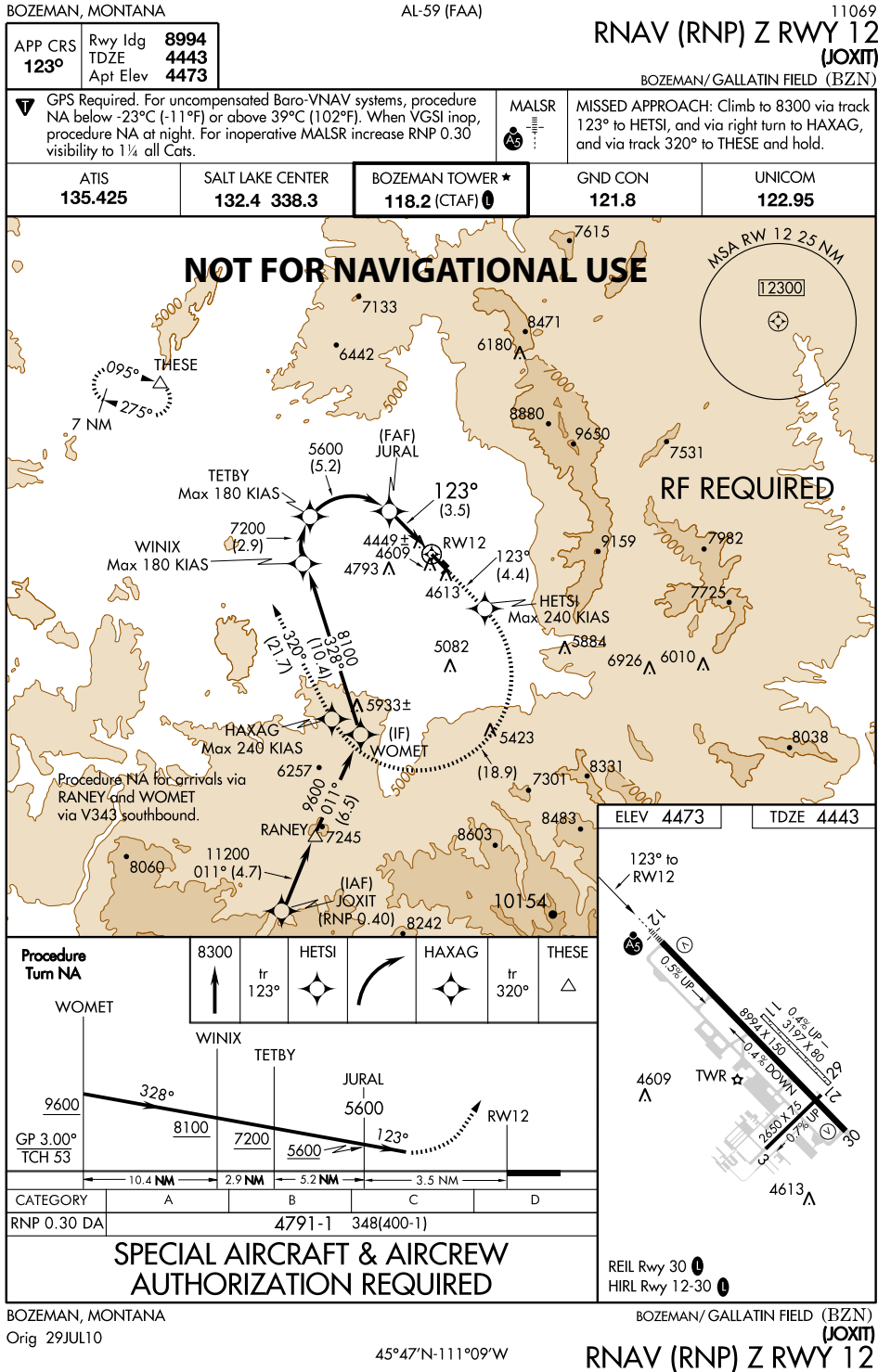

BZN RNAV (RNP) Z RWY 12 (Page 3)

BOZEMAN, MONTANA		AL-59 (FAA)	11069	
APP CRS 123°	Rwy Idg 8994	TDZE 4443	RNAV (RNP) Z RWY 12 (GODFE/THESE/WHITEHALL) BOZEMAN/GALLATIN FIELD (BZN)	
GPS Required. For uncompensated Baro-VNAV systems, procedure NA below -23°C (-11°F) or above 39°C (102°F). When VGSI inop, procedure NA at night. For inoperative MALSRL increase RNP 0.30 visibility to 1 1/4 all Cats.		MALSRL 	MISSED APPROACH: Climb to 8300 via track 123° to HETSJ, and via right turn to HAXAG, and via track 320° to THESE and hold.	
ATIS 135.425	SALT LAKE CENTER 132.4 338.3	BOZEMAN TOWER ★ 118.2 (CTAF) 0	GND CON 121.8	UNICOM 122.95
NOT FOR NAVIGATIONAL USE		ELEV 4473	TDZE 4443	
Procedure Turn NA HUXAN: 8300 WOSAG: 7400 JURAL: 5600 RW12: 4609		HETSJ: tr 123°	HAXAG: tr 320°	THESE: tr 123°
GP 3.00° TCH 53		CATEGORY: A, B, C, D RNP 0.30 DA: 4791-1, 348(400-1)		
SPECIAL AIRCRAFT & AIRCREW AUTHORIZATION REQUIRED				
BOZEMAN, MONTANA Orig 29JUL10		BOZEMAN/GALLATIN FIELD (BZN) (GODFE/THESE/WHITEHALL) RNAV (RNP) Z RWY 12		

NW-1, 10 MAR 2011 to 07 APR 2011

NW-1, 10 MAR 2011 to 07 APR 2011

PSP RNAV (RNP) Y RWY 31L (Page 1)

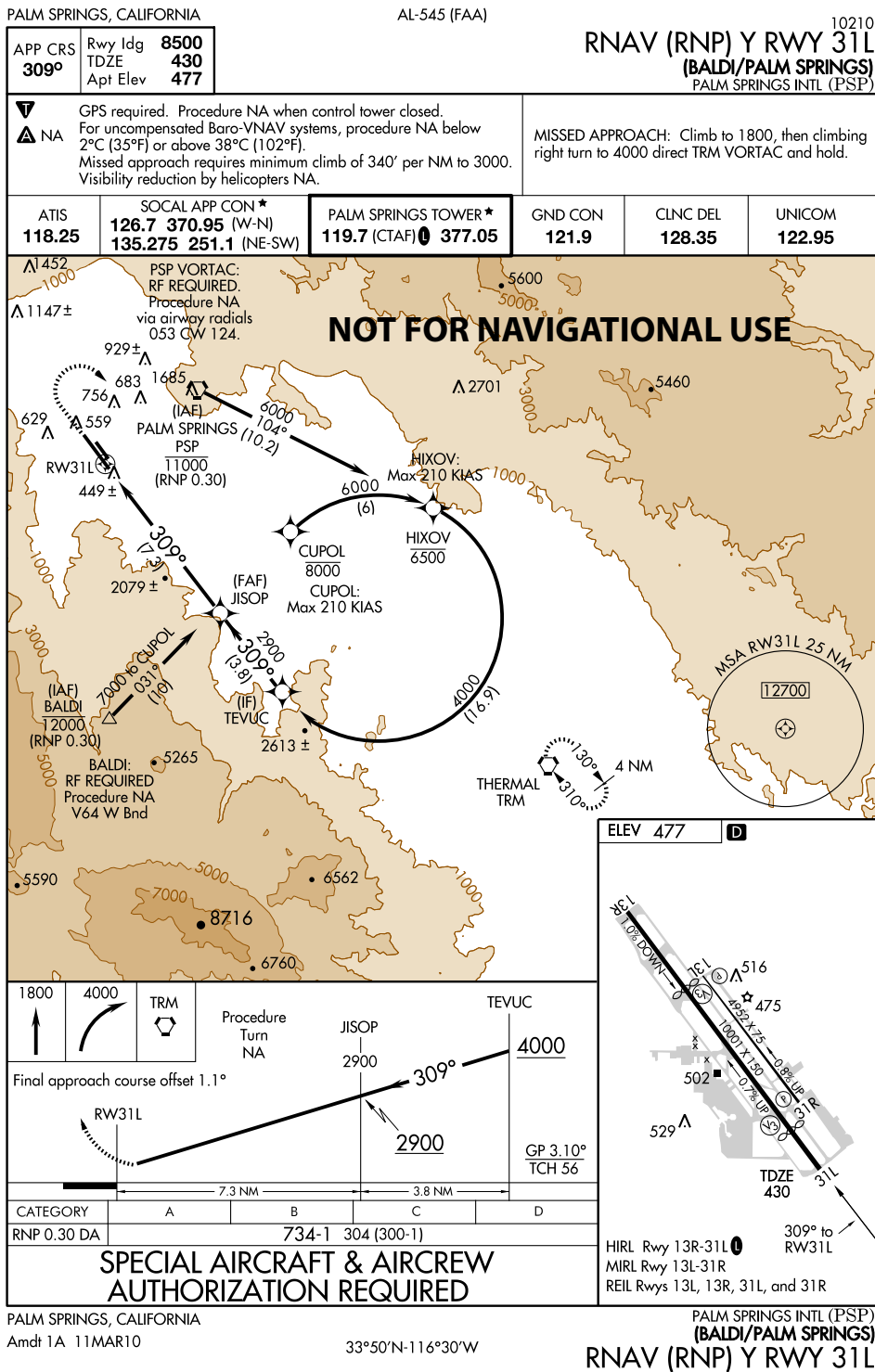

PSP RNAV (RNP) Y RWY 31L (Page 2)

PALM SPRINGS, CALIFORNIA

AL-545 (FAA)

10210

APP CRS 309°	Rwy Idg 8500
	TDZE 430
	Apt Elev 477

RNAV (RNP) Y RWY 31L
(CLOWD/SBONO)
PALM SPRINGS INTL (PSP)

GPS required. Procedure NA when control tower closed.
NA For uncompensated Baro-VNAV systems, procedure NA below 2°C (35°F) or above 38°C (102°F).
 Missed approach requires minimum climb of 340' per NM to 3000.
 Visibility reduction by helicopters NA.

MISSED APPROACH: Climb to 1800, then climbing right turn to 4000 direct TRM VORTAC and hold.

ATIS 118.25	SOCAL APP CON * 126.7 370.95 (W-N) 135.275 251.1 (NE-SW)	PALM SPRINGS TOWER * 119.7 (CTAF) 377.05	GND CON 121.9	CLNC DEL 128.35	UNICOM 122.95
-----------------------	--	--	-------------------------	---------------------------	-------------------------

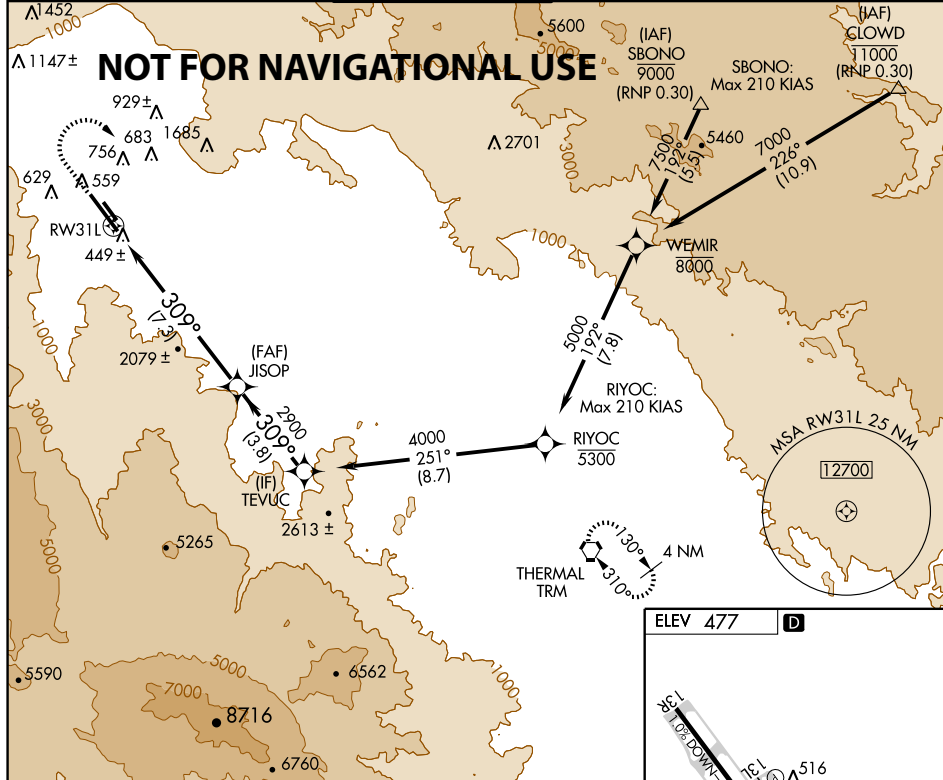

SW-3, 10 MAR 2011 to 07 APR 2011

SW-3, 10 MAR 2011 to 07 APR 2011

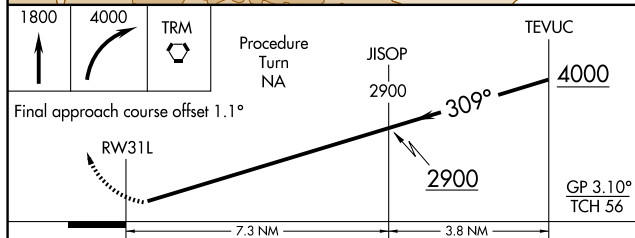

CATEGORY	A	B	C	D
RNP 0.30 DA		734-1	304 (300-1)	

SPECIAL AIRCRAFT & AIRCREW AUTHORIZATION REQUIRED

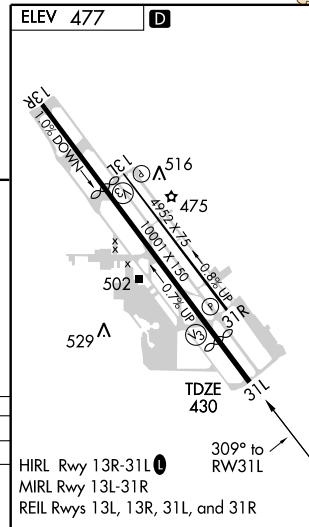

HIRL Rwy 13R-31L
 MIRL Rwy 13L-31R
 REIL Rwy 13L, 13R, 31L, and 31R

PALM SPRINGS, CALIFORNIA

Amdt 1A 11MAR10

33°50'N-116°30'W

PALM SPRINGS INTL (PSP)

(CLOWD/SBONO)

RNAV (RNP) Y RWY 31L

PSP RNAV (RNP) Y RWY 31L (Page 3)

PALM SPRINGS, CALIFORNIA

AL-545 (FAA)

10210

RNAV (RNP) Y RWY 31L (THERMAL)

PALM SPRINGS INTL (PSP)

APP CRS 309°	Rwy Idg 8500
	TDZE 430
	Apt Elev 477

▽ GPS required. Procedure NA when control tower closed.
▲ NA For uncompensated Baro-VNAV systems, procedure NA below 2°C (35°F) or above 38°C (102°F).
 Missed approach requires minimum climb of 340' per NM to 3000.
 Visibility reduction by helicopters NA.

MISSED APPROACH: Climb to 1800, then climbing right turn to 4000 direct TRM VORTAC and hold.

ATIS 118.25	SOCAL APP CON * 126.7 370.95 (W-N) 135.275 251.1 (NE-SW)	PALM SPRINGS TOWER * 119.7 (CTAF) 0 377.05	GND CON 121.9	CLNC DEL 128.35	UNICOM 122.95
-----------------------	--	--	-------------------------	---------------------------	-------------------------

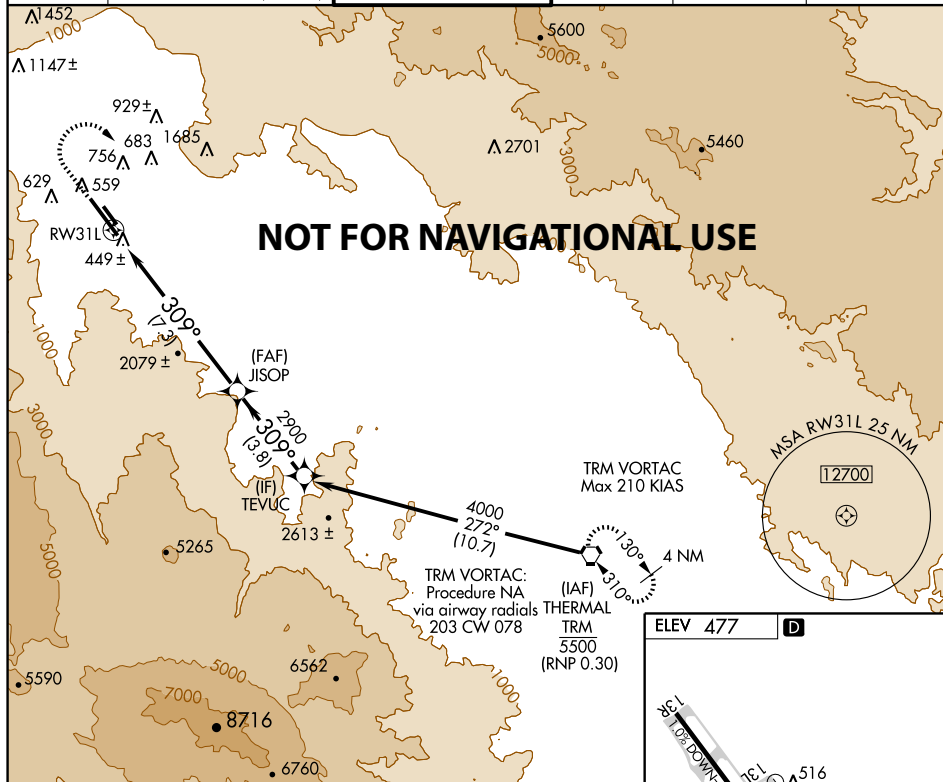

SW-3, 10 MAR 2011 to 07 APR 2011

SW-3, 10 MAR 2011 to 07 APR 2011

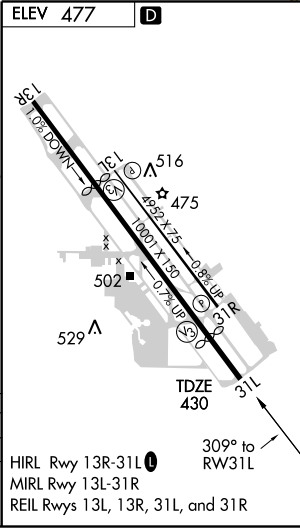
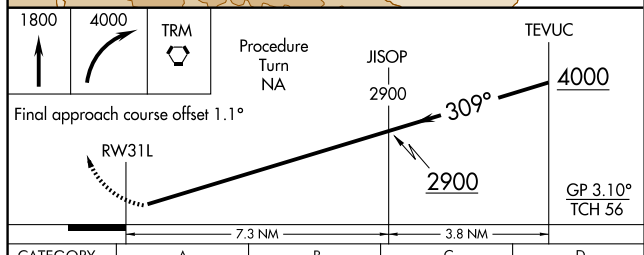

CATEGORY	A	B	C	D
RNP 0.30 DA		734-1	304 (300-1)	

**SPECIAL AIRCRAFT & AIRCREW
AUTHORIZATION REQUIRED**

HIRL Rwy 13R-31L
 MIRL Rwy 13L-31R
 REIL Rwy 13L, 13R, 31L, and 31R

PALM SPRINGS, CALIFORNIA

PALM SPRINGS INTL (PSP)

Amdt 1A 11MART0

33°50'N-116°30'W

RNAV (RNP) Y RWY 31L (THERMAL)

(LEETZ2.LEETZ) 11069
 LEETZ TWO DEPARTURE (RNAV)
 (ROCK SPRINGS)

SL-365 (FAA)

SALT LAKE CITY INTL (SLC)
 SALT LAKE CITY, UTAH

SW-4, 10 MAR 2011 to 07 APR 2011

NOTE: For Non-GPS equipped aircraft:
 OGD and TCH DME must be operational for ROCK SPRINGS transitions.

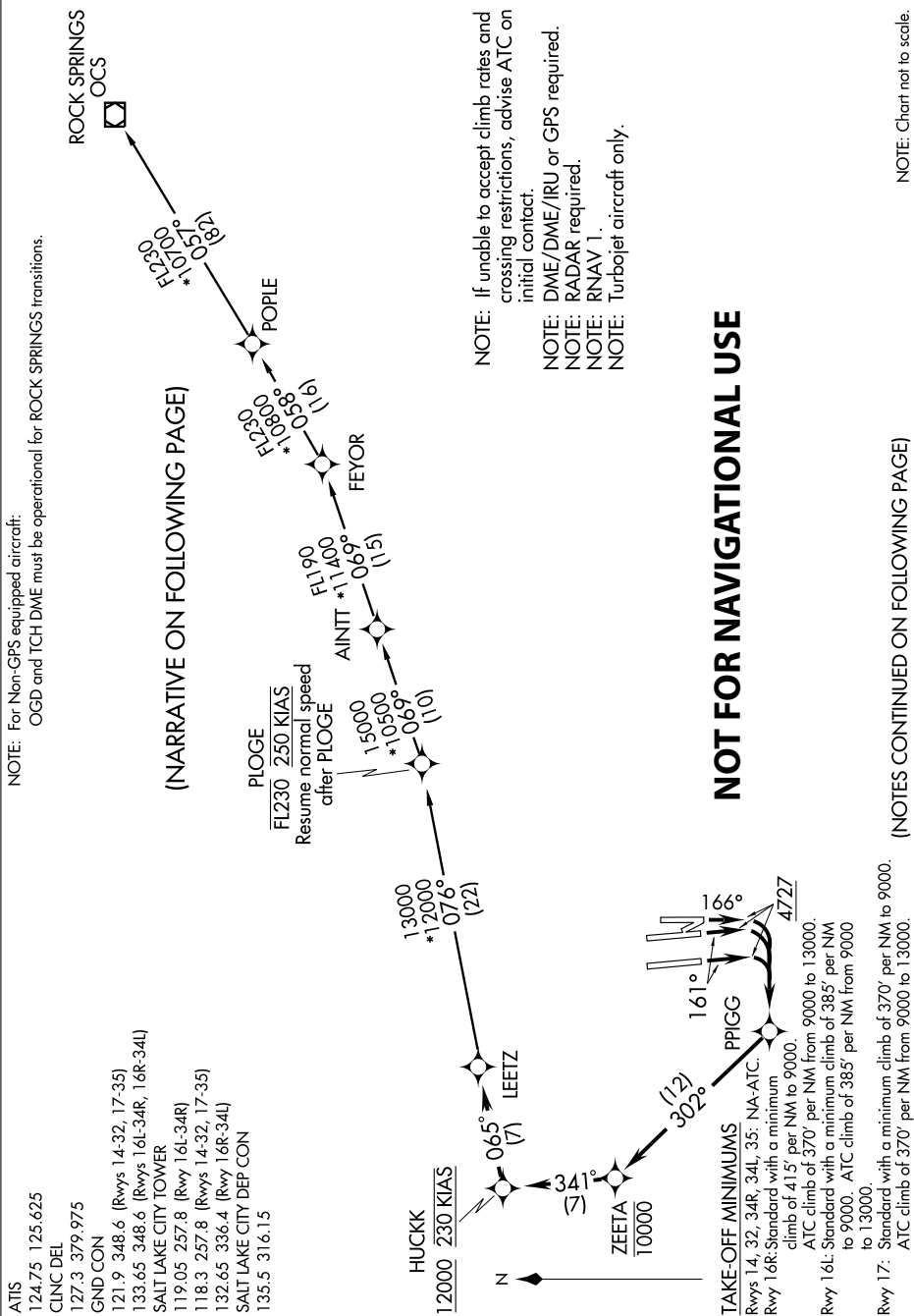

LEETZ TWO DEPARTURE (RNAV)
 (ROCK SPRINGS)
 (LEETZ2.LEETZ) 11069

SALT LAKE CITY, UTAH
 SALT LAKE CITY INTL (SLC)

(NOTES CONTINUED ON FOLLOWING PAGE)

SW-4, 10 MAR 2011 to 07 APR 2011

SW-4, 10 MAR 2011 to 07 APR 2011

NOTE: For Non-GPS equipped aircraft:
 OGD, TCH, FFU, and LHO DME must be operational for HOLTR transitions.

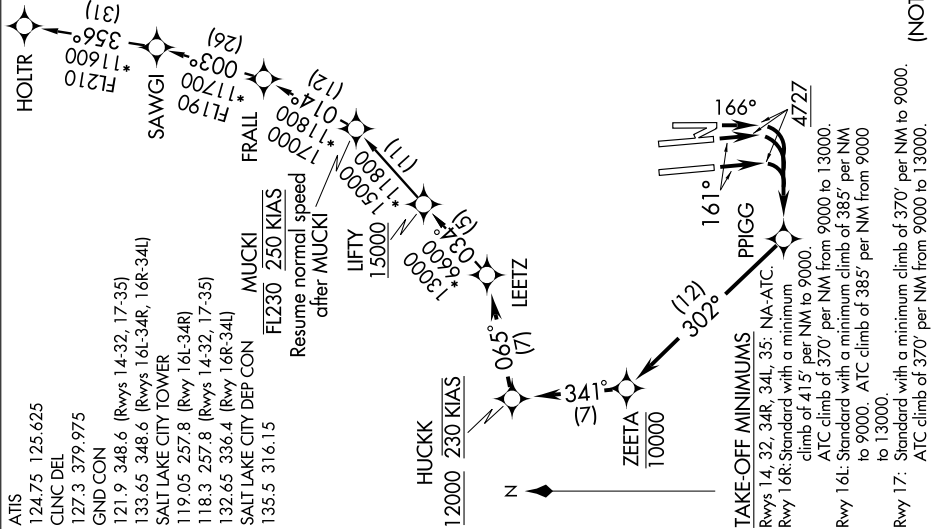

NOTE: If unable to accept climb rates and crossing restrictions, advise ATC on initial contact.
 NOTE: DME/DME/IRU or GPS required.
 NOTE: RADAR required.
 NOTE: RNAV 1
 NOTE: Turbojet aircraft only.

NOT FOR NAVIGATIONAL USE

NOTE: Chart not to scale.

(NOTES CONTINUED ON FOLLOWING PAGE)

SW-4, 10 MAR 2011 to 07 APR 2011

SW-4, 10 MAR 2011 to 07 APR 2011

NOTE: For Non-GPS equipped aircraft:
 OGD, TCH, BVL, and MID DME must be operational for HAYDEN transitions.
 OGD, TCH, BVL, OCS, and MID DME must be operational for MEEKER transitions.
 OGD, TCH, BVL, and FFU DME must be operational for MYTON transitions.

(NARRATIVE ON FOLLOWING PAGE)

NOT FOR NAVIGATIONAL USE

ATIS
 124.75 125.625
 CLNC DEL
 127.3 379.975
 GND CON
 121.9 348.6 (Rwys 14-32, 17-35)
 133.65 348.6 (Rwys 16L-34R, 16R-34L)
 SALT LAKE CITY TOWER
 119.05 257.8 (Rwy 16L-34R)
 118.3 257.8 (Rwys 14-32, 17-35)
 132.65 336.4 (Rwy 16R-34L)
 SALT LAKE CITY DEP CON
 135.5 316.15

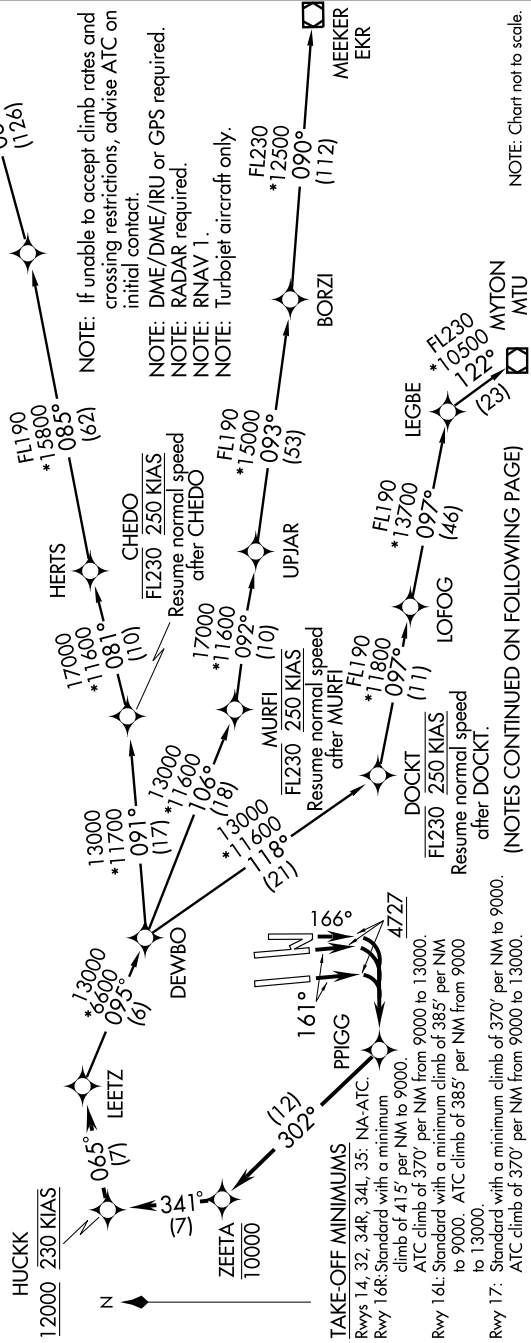

NOTE: Chart not to scale.

(NOTES CONTINUED ON FOLLOWING PAGE)

SW-4, 10 MAR 2011 to 07 APR 2011

(SHEAD7.SHEAD) 11013
 SHEAD SEVEN DEPARTURE (RNAV)
 (RWYS 7L/R, 25L/R)

SL-662 (FAA) LAS VEGAS / MC CARRAN INTL (LAS)
 LAS VEGAS, NEVADA

SW-4, 10 MAR 2011 to 07 APR 2011

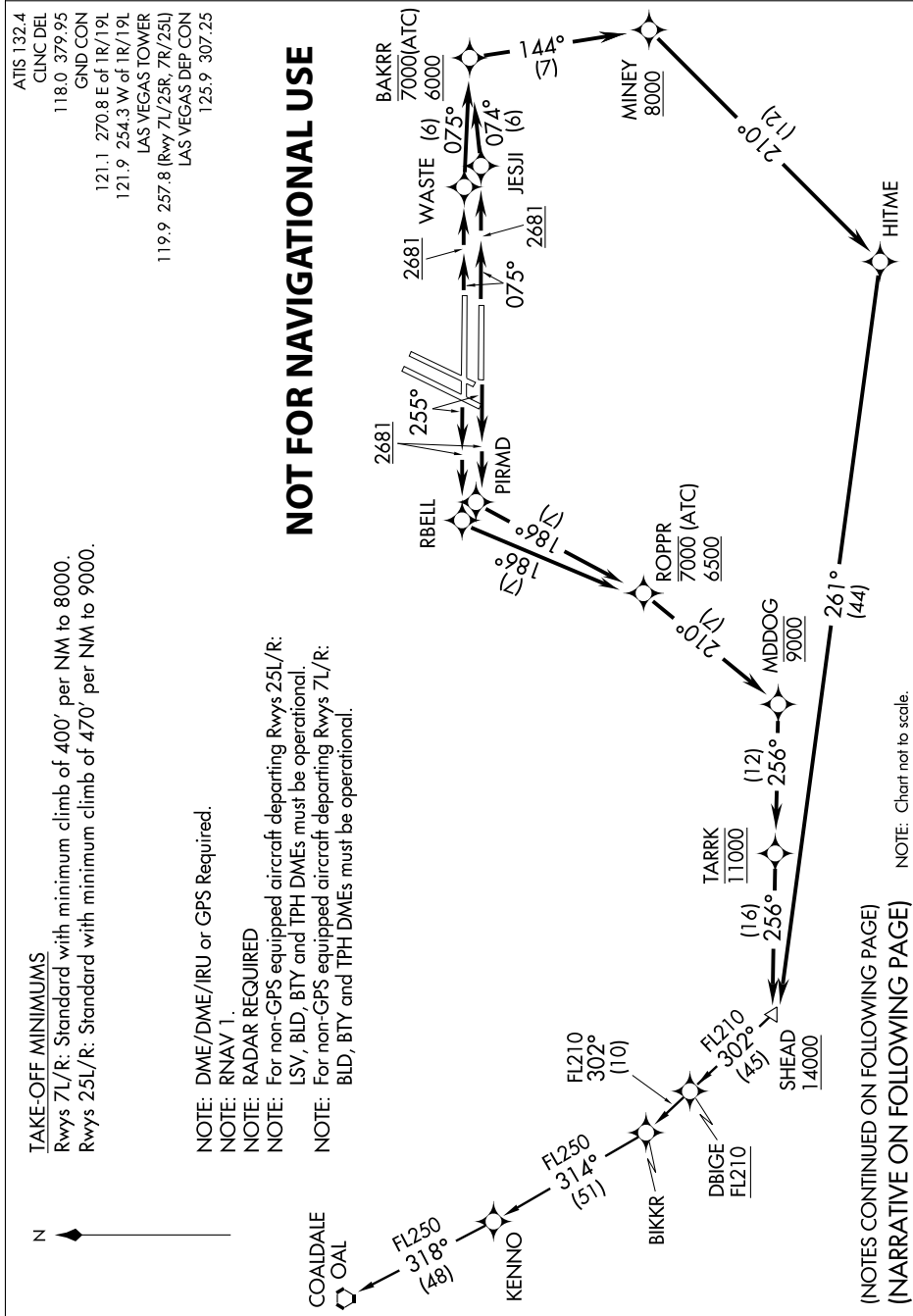

SHEAD SEVEN DEPARTURE (RNAV)
 (RWYS 7L/R, 25L/R)
 (SHEAD7.SHEAD) 11013

LAS VEGAS, NEVADA
 LAS VEGAS / MC CARRAN INTL (LAS)

SW-4, 10 MAR 2011 to 07 APR 2011

(SHEAD7.SHEAD) 11013
 SHEAD SEVEN DEPARTURE (RNAV)
 (RWYS 1L/R, 19L/R)

SL-662 (FAA)

LAS VEGAS / MC CARRAN INTL (LAS)
 LAS VEGAS, NEVADA

SW-4, 10 MAR 2011 to 07 APR 2011

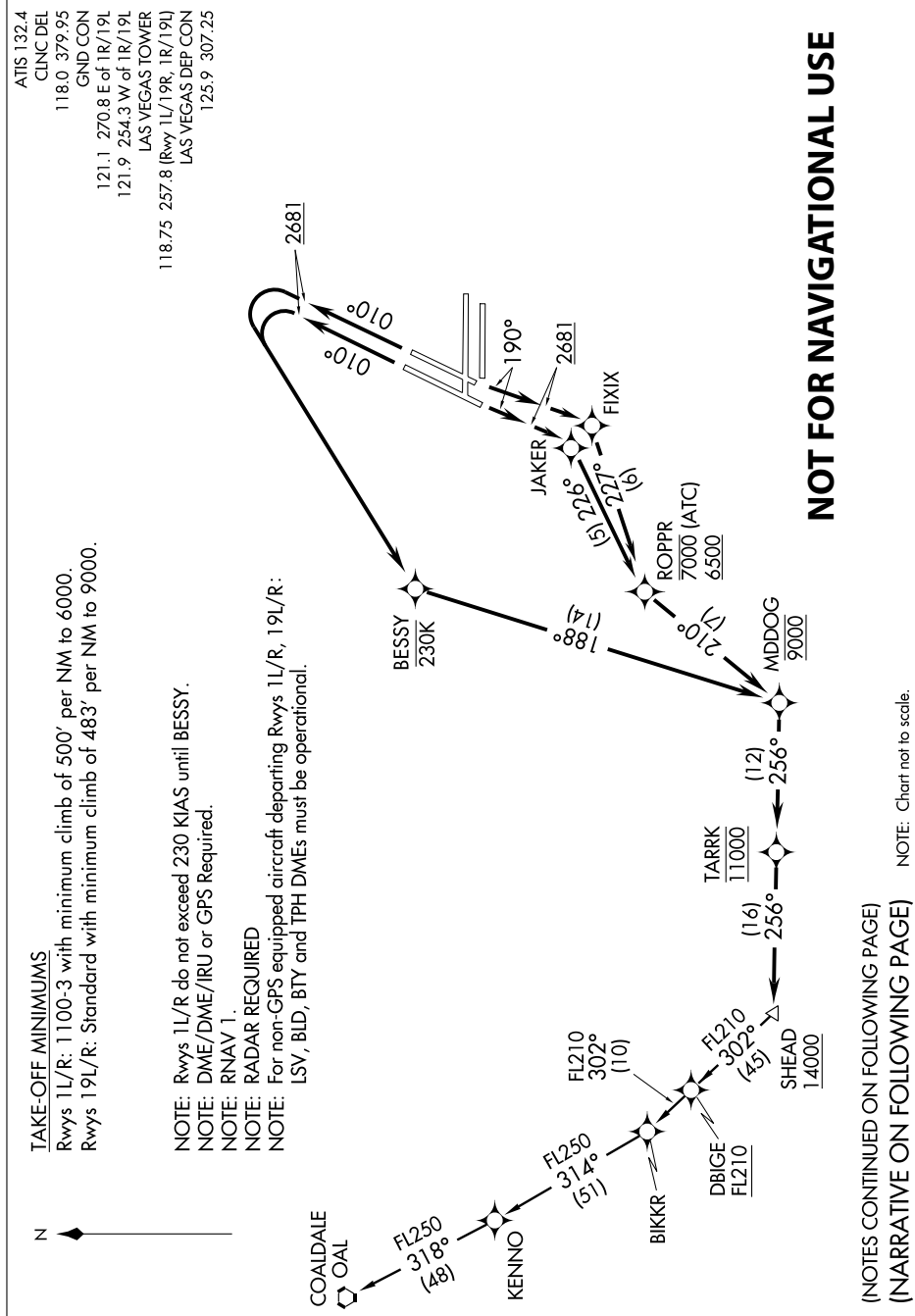

TAKE-OFF MINIMUMS

Rwys 1L/R: 1100-3 with minimum climb of 500' per NM to 6000.
 Rwys 19L/R: Standard with minimum climb of 483' per NM to 9000.

NOTE: Rwys 1L/R do not exceed 230 KIAS until BESSY.

NOTE: DME/DME/IRU or GPS Required.

NOTE: RNAV 1.

NOTE: RADAR REQUIRED

NOTE: For non-GPS equipped aircraft departing Rwys 1L/R, 19L/R:
 LSV, BLD, BTY and TPH DMEs must be operational.

SHEAD SEVEN DEPARTURE (RNAV)
 (RWYS 1L/R, 19L/R)
 (SHEAD7.SHEAD) 11013

LAS VEGAS, NEVADA
 LAS VEGAS / MC CARRAN INTL (LAS)

SW-4, 10 MAR 2011 to 07 APR 2011

(DARTZ3.DARTZ) 10098
 DARTZ THREE DEPARTURE (RNAV)
 (RWYS 35L/C, 36L/R)

DALLAS FORT WORTH INTL (DFW)
 SL-6039 (FAA) DALLAS-FORT WORTH, TEXAS

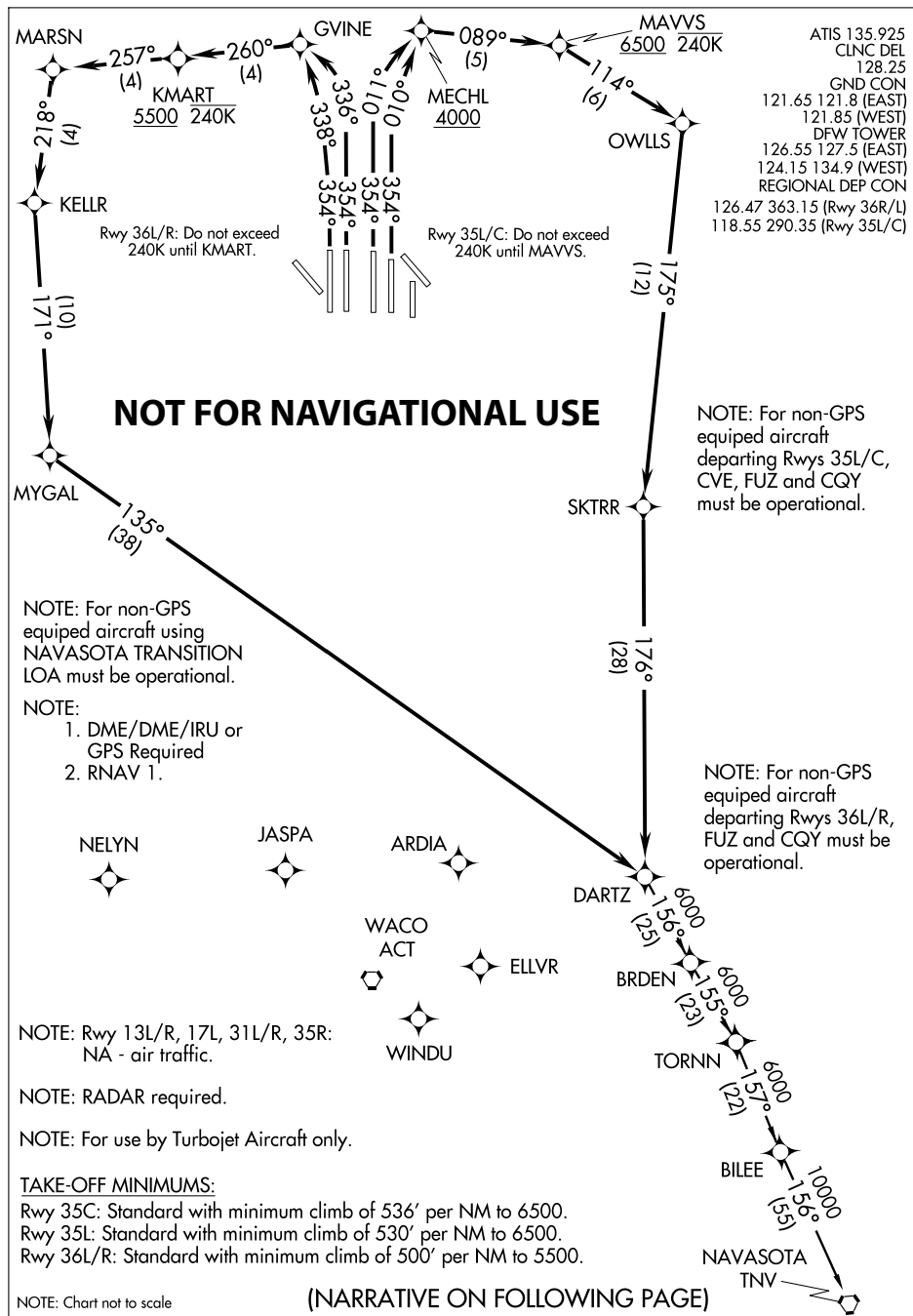

SC-2, 10 MAR 2011 to 07 APR 2011

SC-2, 10 MAR 2011 to 07 APR 2011

DARTZ THREE DEPARTURE (RNAV)
 (RWYS 35L/C, 36L/R)
 (DARTZ3.DARTZ) 10098

DALLAS-FORT WORTH, TEXAS
 DALLAS FORT WORTH INTL (DFW)

(DARTZ3.DARTZ) 10098
 DARTZ THREE DEPARTURE (RNAV)
 (RWYS 17C/R, 18L/R)

DALLAS FORT WORTH INTL (DFW)
 SL-6039 (FAA) DALLAS-FORT WORTH, TEXAS

NOT FOR NAVIGATIONAL USE

ATIS 135.925
 CLNC DEL 128.25
 GND CON 121.65 121.8 (EAST)
 121.85 (WEST)
 DFW TOWER 126.55 127.5 (EAST)
 124.15 134.9 (WEST)
 REGIONAL DEP CON 125.12 353.95 (Rwy 17R/C)
 125.12 353.95 (Rwy 18R/L)

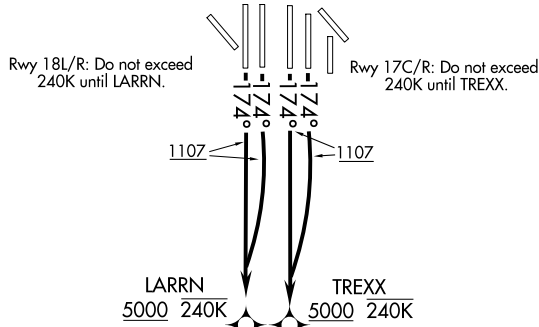

NOTE: For non-GPS equipped aircraft using NAVASOTA TRANSITION LOA must be operational.

- NOTE:
 1. DME/DME/IRU or GPS Required
 2. RNAV 1.

NOTE: For non-GPS equipped aircraft departing Rwy's 17C/R, 18L/R, CVE and FUZ must be operational.

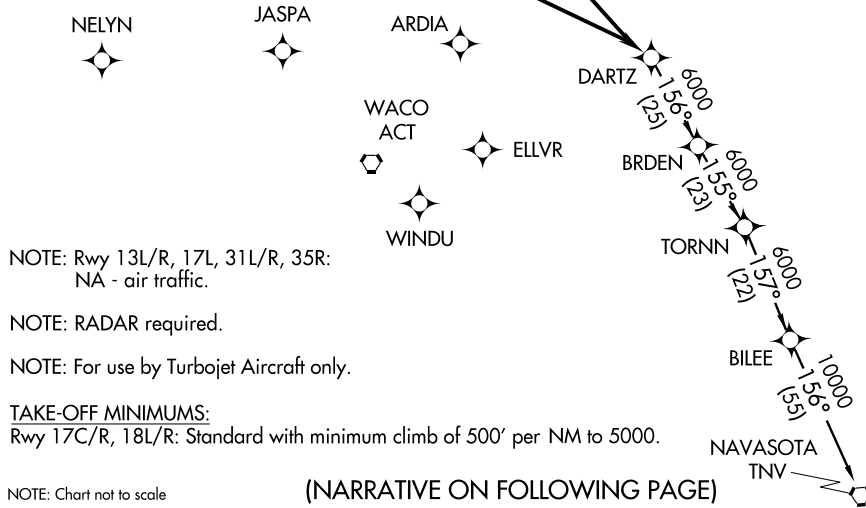

NOTE: Rwy 13L/R, 17L, 31L/R, 35R: NA - air traffic.

NOTE: RADAR required.

NOTE: For use by Turbojet Aircraft only.

TAKE-OFF MINIMUMS:
 Rwy 17C/R, 18L/R: Standard with minimum climb of 500' per NM to 5000.

NOTE: Chart not to scale

(NARRATIVE ON FOLLOWING PAGE)

DARTZ THREE DEPARTURE (RNAV)
 (RWYS 17C/R, 18L/R)
 (DARTZ3.DARTZ) 10098

DALLAS-FORT WORTH, TEXAS
 DALLAS FORT WORTH INTL (DFW)

SC-2, 10 MAR 2011 to 07 APR 2011

SC-2, 10 MAR 2011 to 07 APR 2011

G3: Jeppesen Current Charts

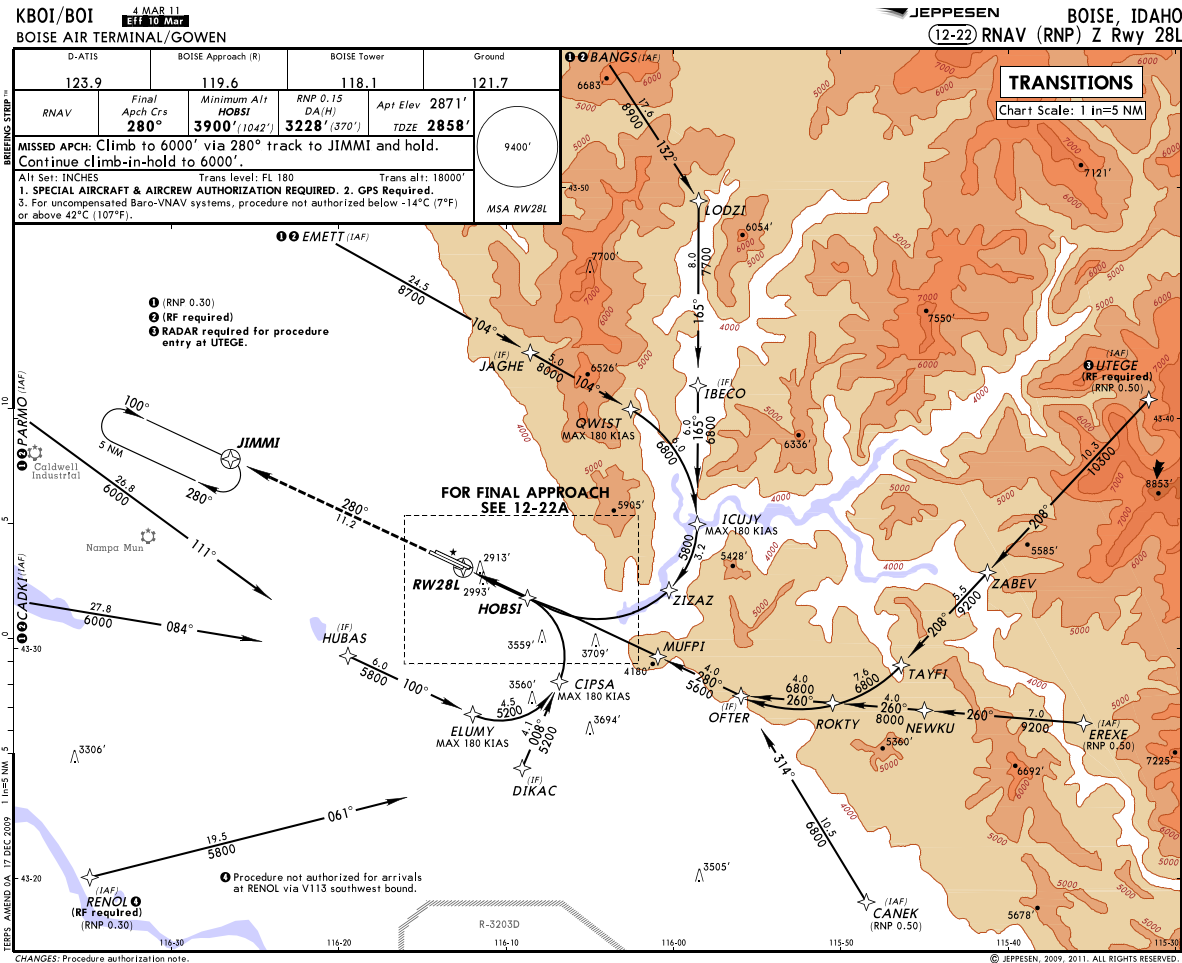

Reproduced with permission of Jeppesen Sanderson, Inc. NOT FOR NAVIGATIONAL USE
 Jeppesen Sanderson, Inc. Copyright © 2011
 Figure reduced for illustrative purposes only

KBOI/BOI

BOISE AIR TERMINAL/GOWEN

JEPPESEN BOISE, IDAHO
 4 MAR 11 Eff 10 Mar (12-22A) RNAV (RNP) Z Rwy 28L

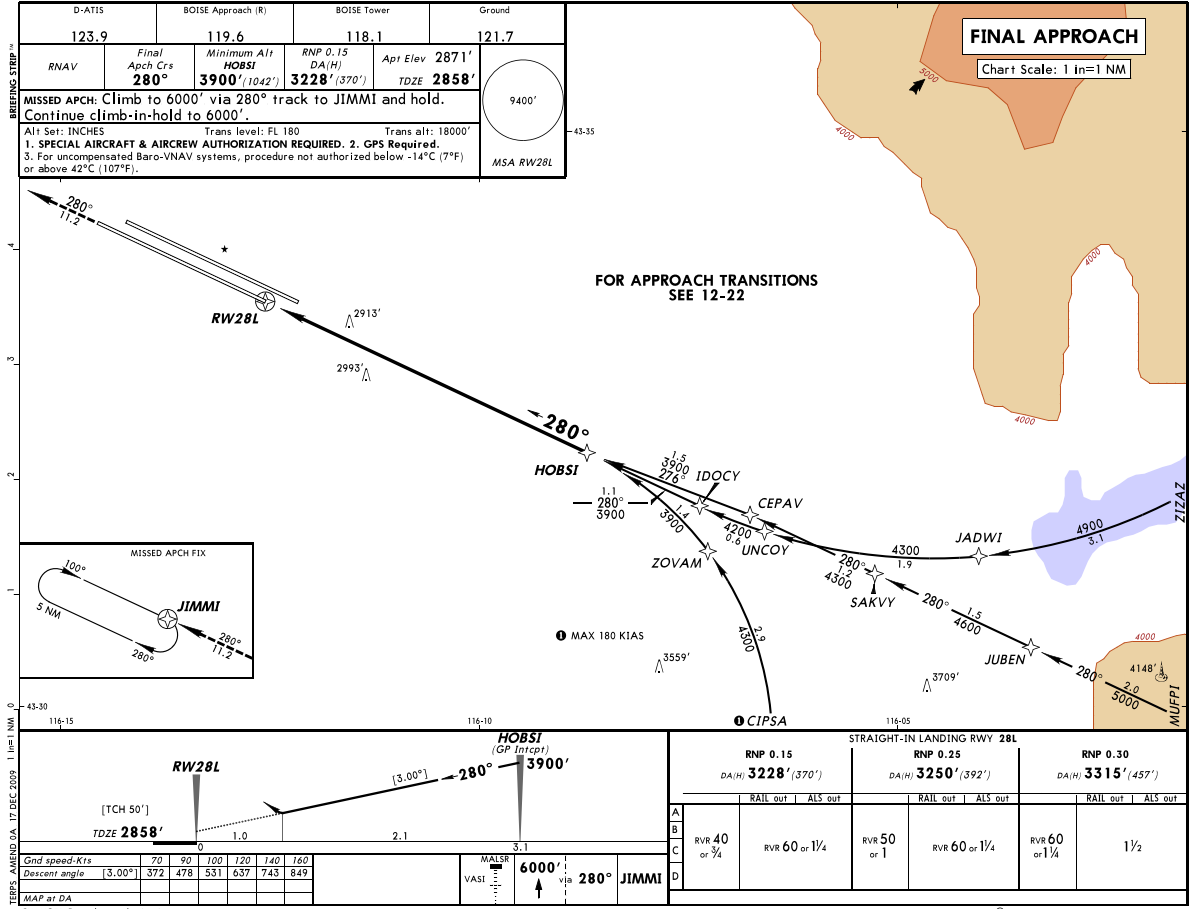

Reproduced with permission of Jeppesen Sanderson, Inc. NOT FOR NAVIGATIONAL USE
 Jeppesen Sanderson, Inc. Copyright © 2011
 Figure reduced for illustrative purposes only

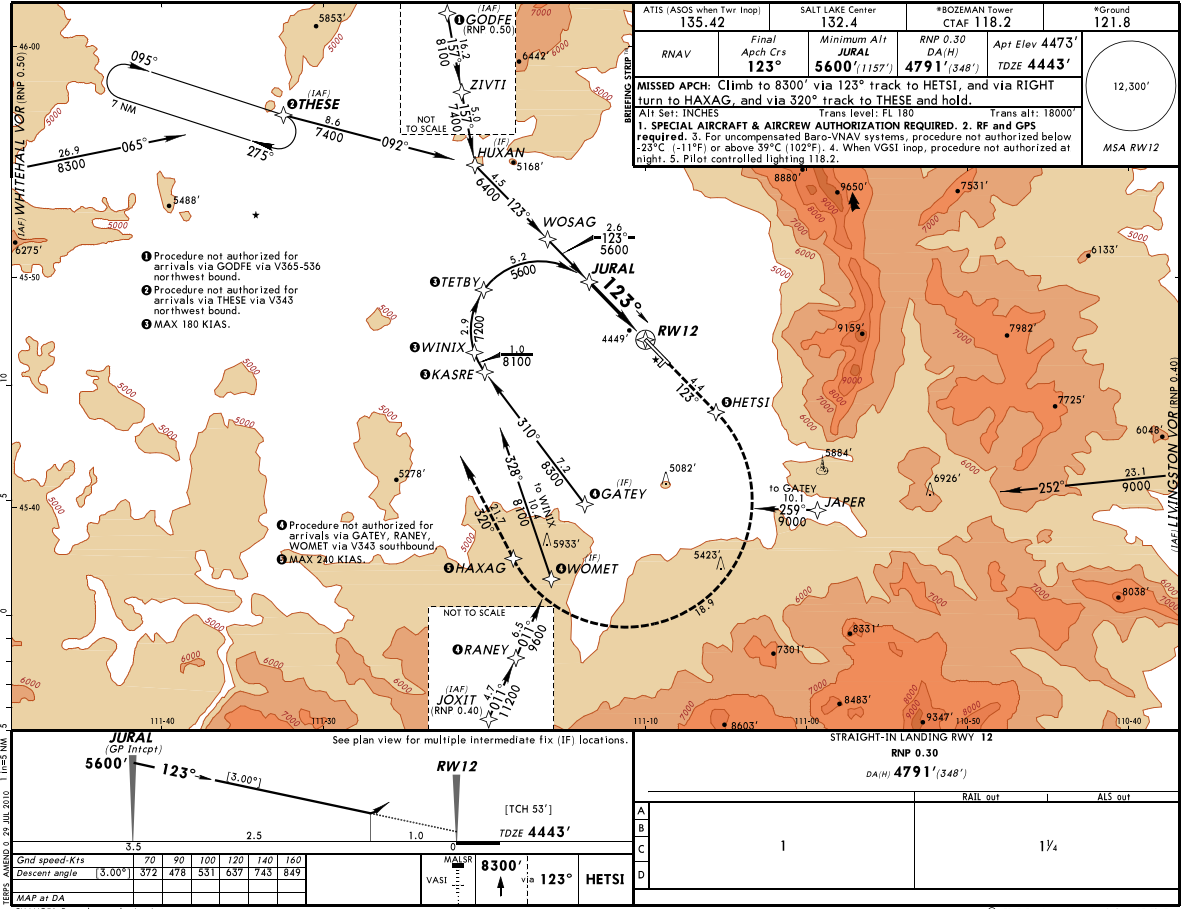

Reproduced with permission of Jeppesen Sanderson, Inc. NOT FOR NAVIGATIONAL USE
Jeppesen Sanderson, Inc. Copyright © 2011
Figure reduced for illustrative purposes only

KPSP/PSP
PALM SPRINGS INTL

JEPPESEN
4 MAR 11
Eff 10 Mar (12-22)

PALM SPRINGS, CALIF
RNAV (RNP) Y Rwy 31L

ATIS (ASOS when Twr inop)	*SOCAL Approach (R) West-North Northeast-Southwest	LOS ANGELES Center (R)	*PALM SPRINGS Tower	*Ground
118.25	126.7 135.27	128.15 when App inop.	CTAF 119.7	121.9
RNAV	Final Apch Crs 309°	Minimum Alt JISOP 2900' (2470')	RNP 0.30 DA(H) 734' (304')	Appt Elev 477' TDZE 430'
MISSED APCH: Climb to 1800', then climbing RIGHT turn to 4000' direct TRM VOR and hold. Missed approach requires minimum climb of 340'/NM to 3000'.				12,700' MSA RW31L
Alt Set: INCHES Trans level: FL 180 Trans alt: 18000'				

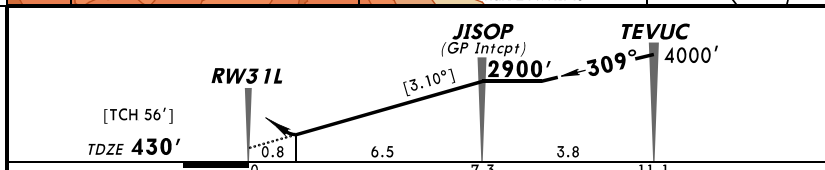
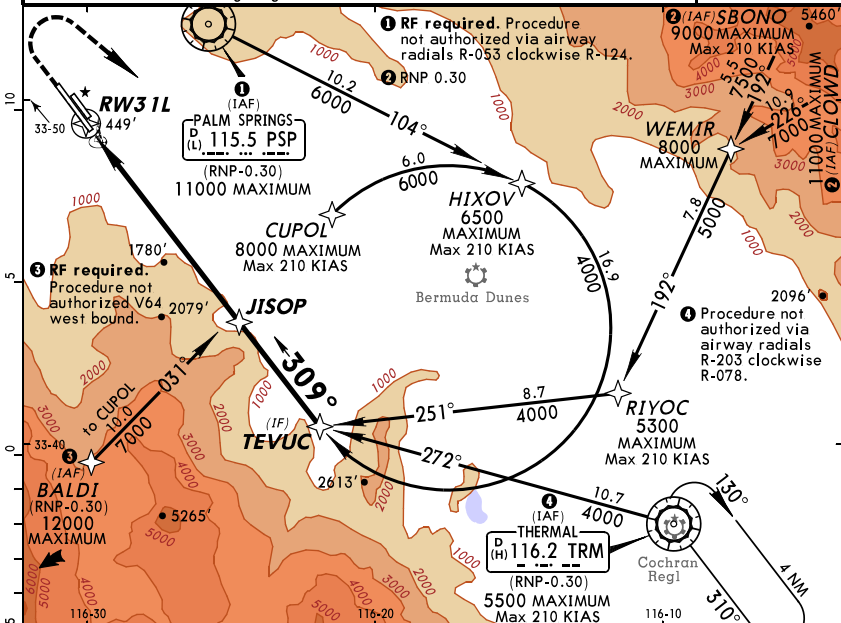

Gnd speed-Kts	70	90	100	120	140	160			
Descent angle [3.10°]	384	494	548	658	768	878	REIL	1800'	4000'
MAP at DA							VASI-L	↑	RT

STRAIGHT-IN LANDING RWY 31L
RNP 0.30
DA(H) **734'** (304')

A	
B	
C	
D	1

CHANGES: Procedure authorization note. © JEPPESEN, 2005, 2011. ALL RIGHTS RESERVED.

Reproduced with permission of Jeppesen Sanderson, Inc. NOT FOR NAVIGATIONAL USE
Jeppesen Sanderson, Inc. Copyright © 2011
Figure reduced for illustrative purposes only

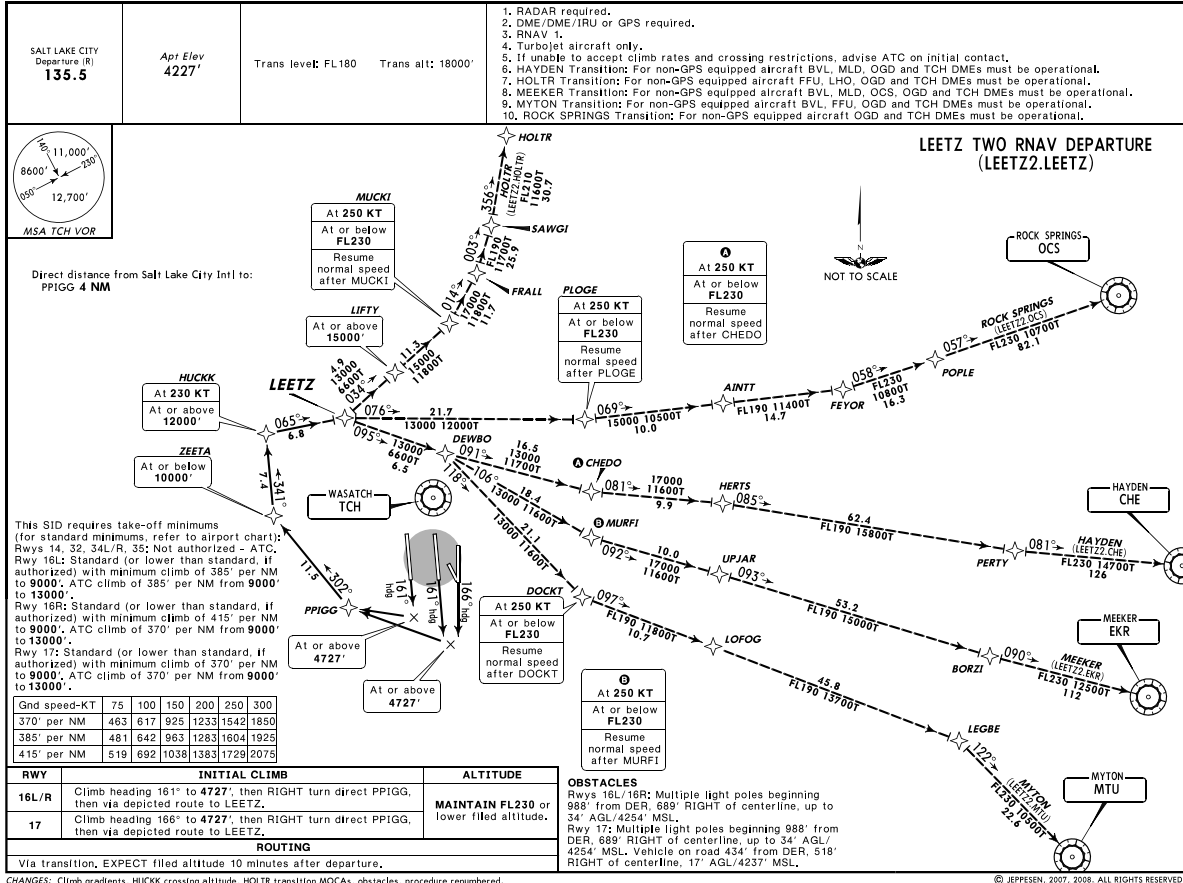

Reproduced with permission of Jeppesen Sanderson, Inc. NOT FOR NAVIGATIONAL USE
Jeppesen Sanderson, Inc. Copyright © 2011
Figure reduced for illustrative purposes only

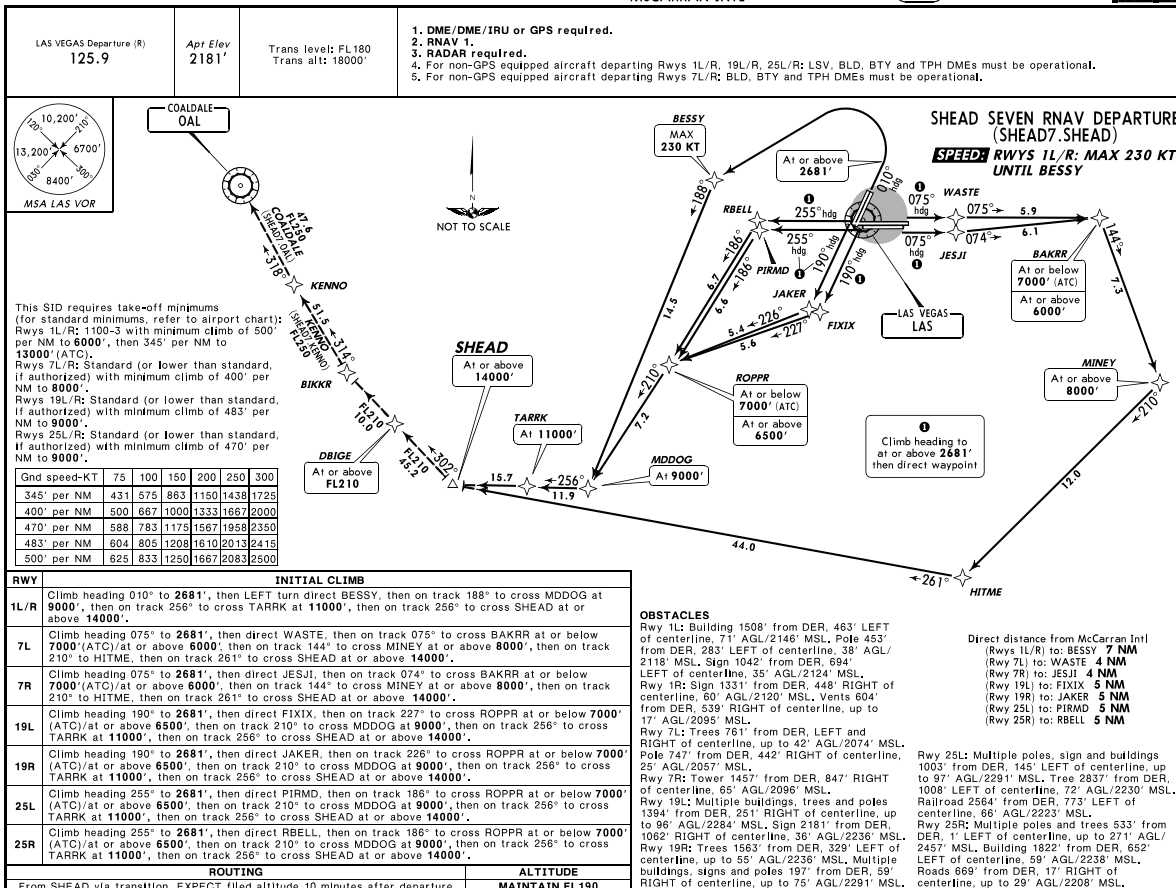

CHANGES: None.

© JEPPESSEN, 2003, 2011. ALL RIGHTS RESERVED.

Reproduced with permission of Jeppesen Sanderson, Inc. NOT FOR NAVIGATIONAL USE
Jeppesen Sanderson, Inc. Copyright © 2011
Figure reduced for illustrative purposes only

1. DME/DME/IRU or GPS required, 2. RADAR required, 3. For Turbo-Jets only 4. RNAV 1, 5. For non-GPS equipped aircraft departing RWYS 17C/R, 18L/R; CVE and FUZ must be operational, 6. For non-GPS equipped aircraft departing RWYS 35L/C; CQY, CVE and FUZ must be operational, 7. For non-GPS equipped aircraft departing RWYS 36L/R; CQY and FUZ must be operational, 8. For non-GPS equipped aircraft using NAVASOTA Transition: LOA must be operational.

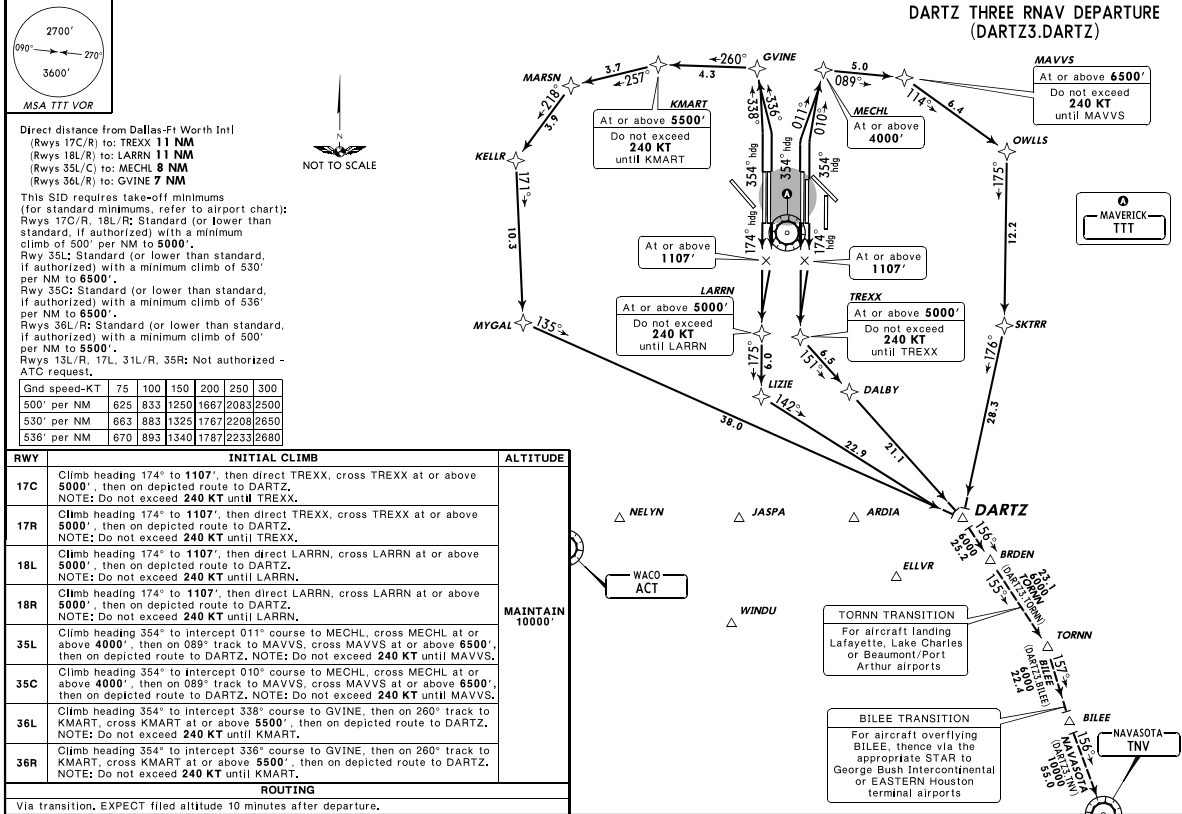

Reproduced with permission of Jeppesen Sanderson, Inc. NOT FOR NAVIGATIONAL USE
 Jeppesen Sanderson, Inc. Copyright © 2011
 Figure reduced for illustrative purposes only

G3: Jeppesen Modified Charts

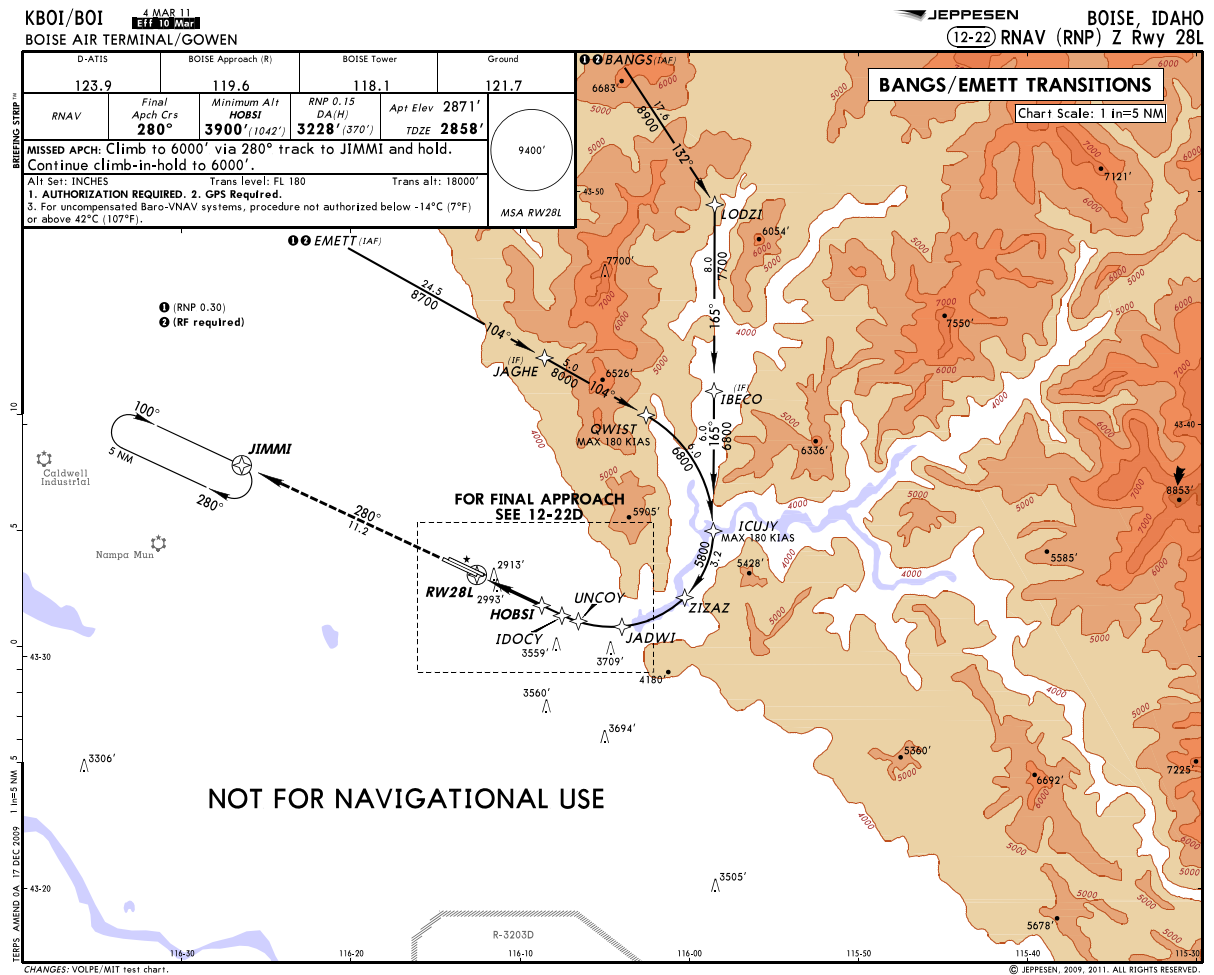

Reproduced with permission of Jeppesen Sanderson, Inc. NOT FOR NAVIGATIONAL USE
 Jeppesen Sanderson, Inc. Copyright © 2011
 Figure reduced for illustrative purposes only

KBOI/BOI ^{4 MAR 11}
 BOISE AIR TERMINAL/GOWEN

JEPPESEN BOISE, IDAHO
 (12-22A) RNAV (RNP) Z Rwy 28L

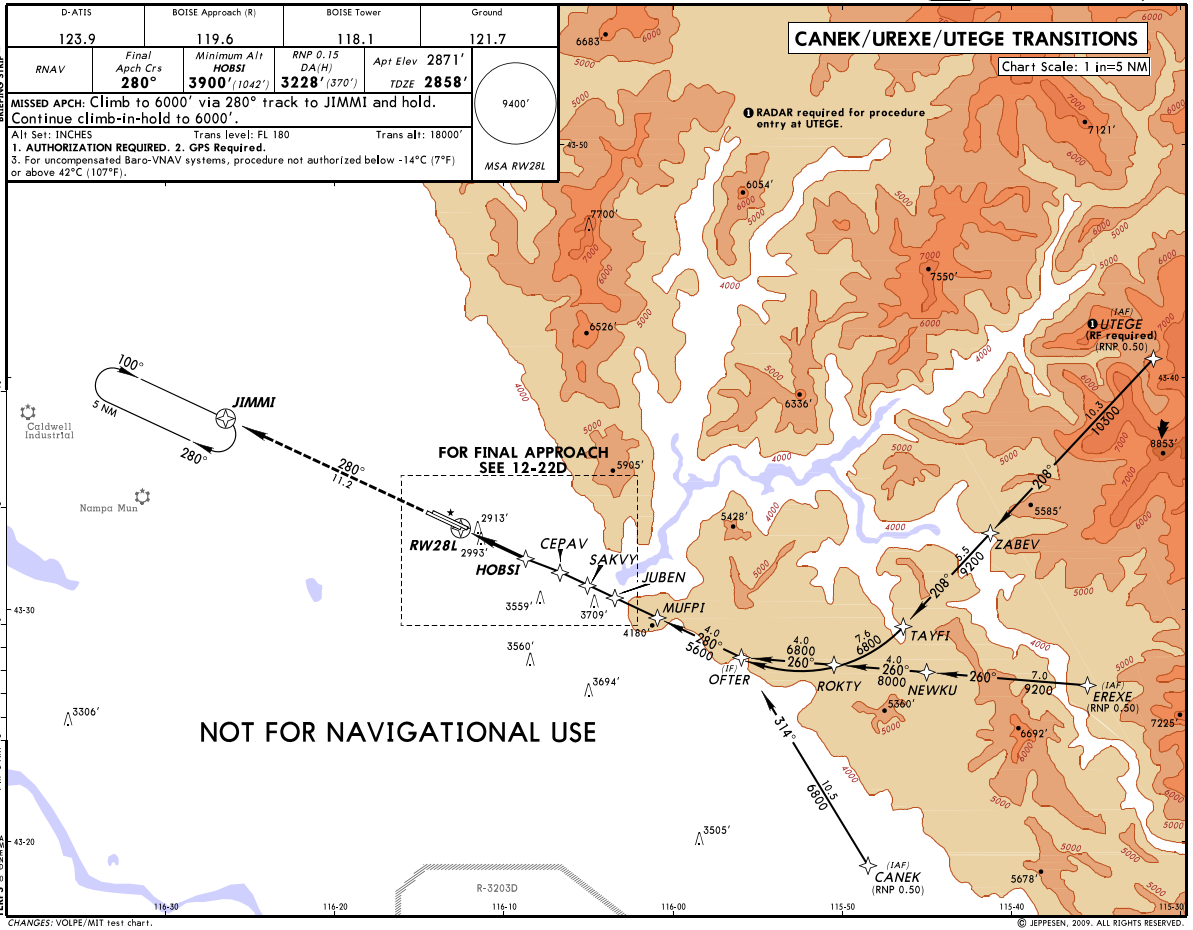

Reproduced with permission of Jeppesen Sanderson, Inc. NOT FOR NAVIGATIONAL USE
 Jeppesen Sanderson, Inc. Copyright © 2011
 Figure reduced for illustrative purposes only

KBOI/BOI 4 MAR 11
 BOISE AIR TERMINAL/GOWEN
 Eff 10 Mar

JEPPESEN BOISE, IDAHO
 (12-22B) RNAV (RNP) Z Rwy 28L

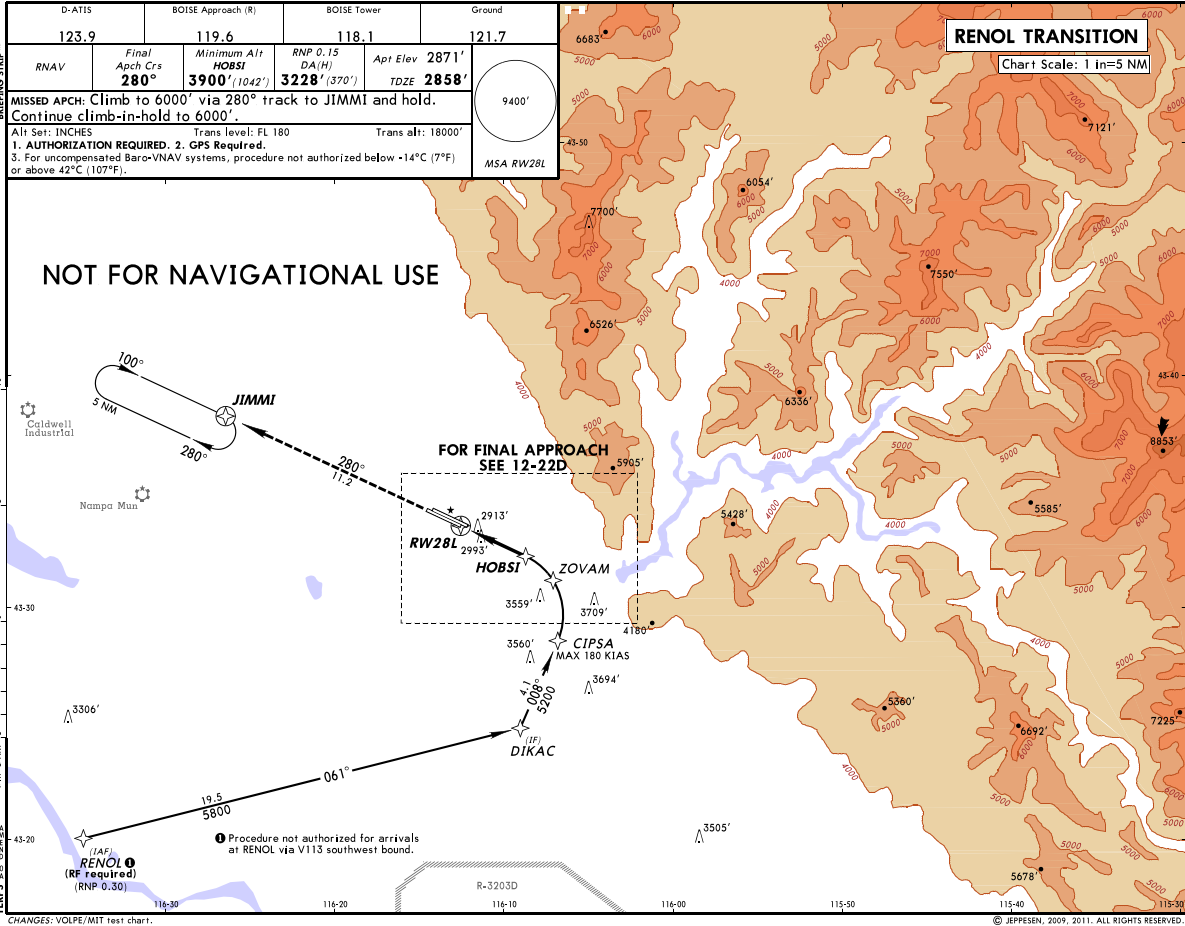

Reproduced with permission of Jeppesen Sanderson, Inc. NOT FOR NAVIGATIONAL USE
 Jeppesen Sanderson, Inc. Copyright © 2011
 Figure reduced for illustrative purposes only

KBOI/BOI 4 MAR 11
 BOISE AIR TERMINAL/GOWEN

JEPPESEN BOISE, IDAHO
 (12-22C) RNAV (RNP) Z Rwy 28L

D-ATIS	BOISE Approach (R)	BOISE Tower	Ground
123.9	119.6	118.1	121.7
RNAV	Final Apch Crs 280°	Minimum Alt HOBSE 3900' (1042')	RNP 0.15 DA(H) 3228' (370')
MISSED APCH: Climb to 6000' via 280° track to JIMMI and hold. Continue climb-in-hold to 6000'.		Api Elev 2871'	TDZE 2858'
All Set: INCHES		Trans level: FL 180	Trans alt: 18000'
1. AUTHORIZATION REQUIRED. 2. GPS Required. 3. For uncompensated Baro-VNAV systems, procedure not authorized below -14°C (7°F) or above 42°C (107°F).			

CADKI/PARMO TRANSITIONS
 Chart Scale: 1 in=5 NM

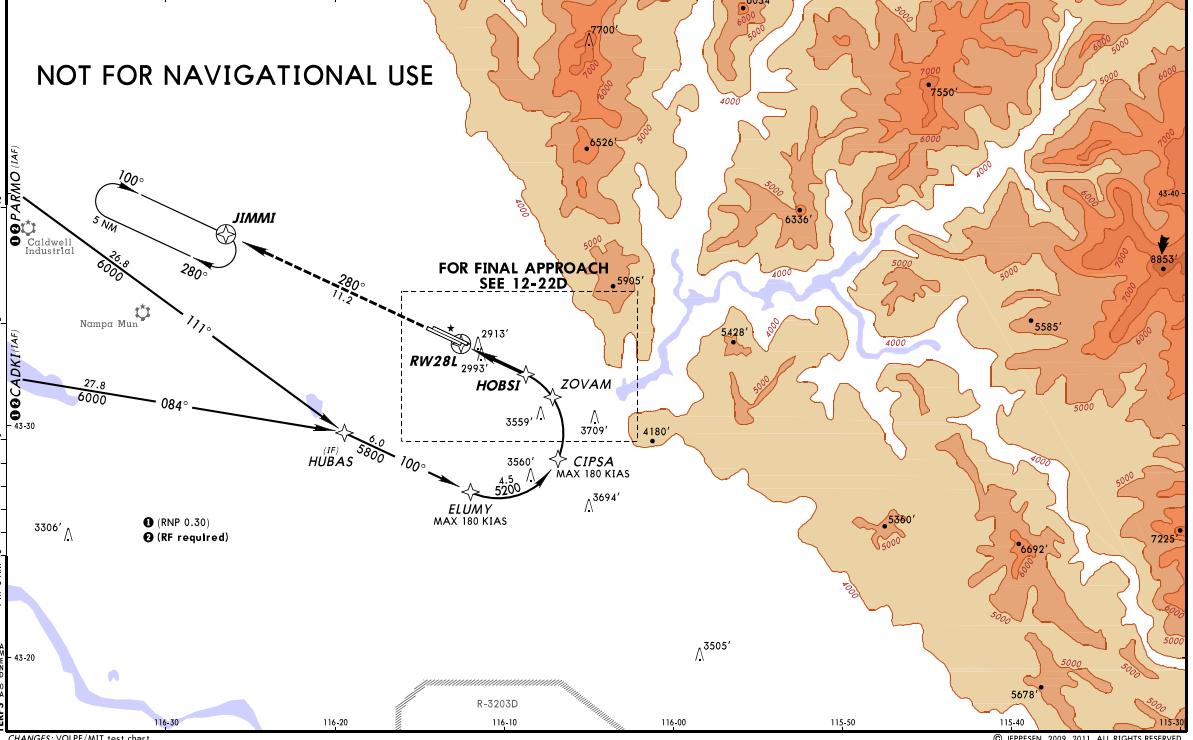

KBOI/BOI 4 MAR 11
 BOISE AIR TERMINAL/GOWEN

JEPPESEN BOISE, IDAHO
 (12-22C) RNAV (RNP) Z Rwy 28L

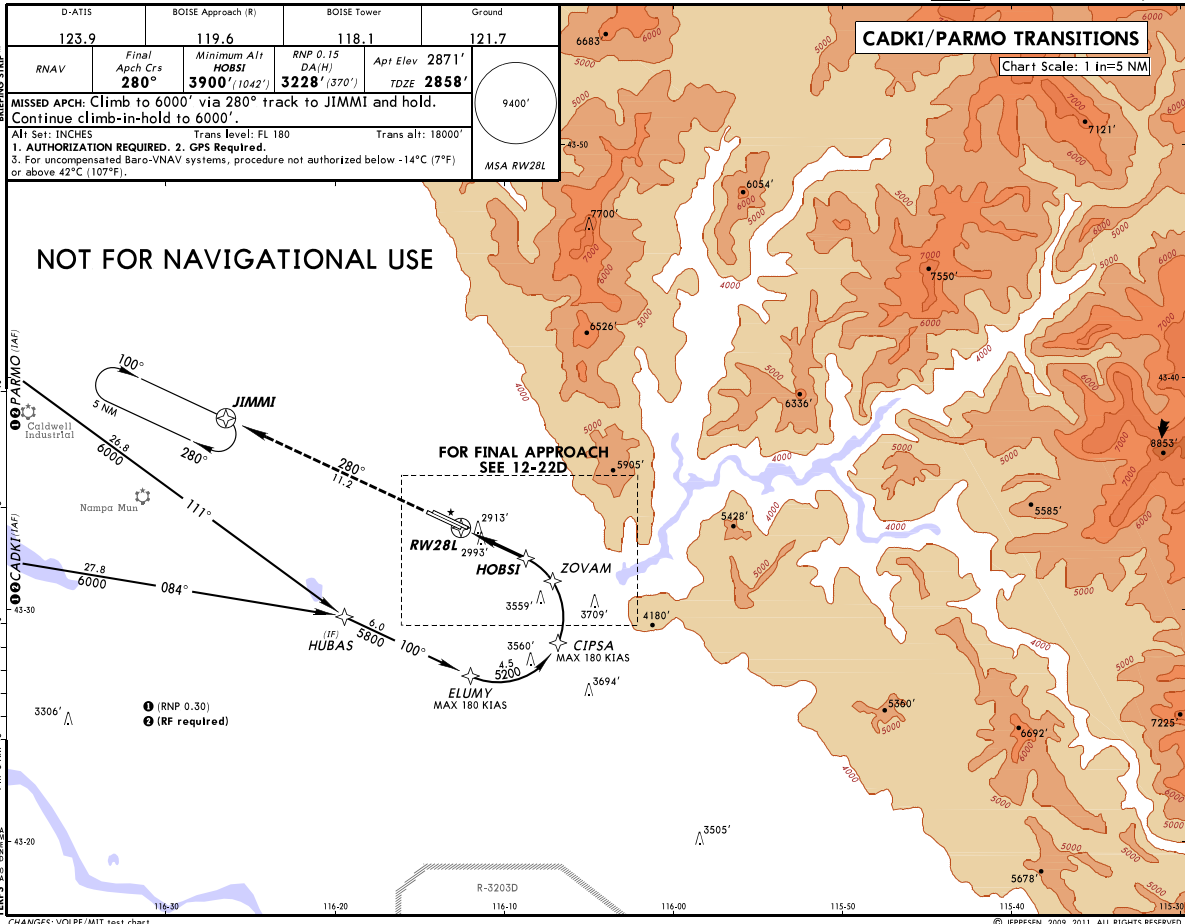

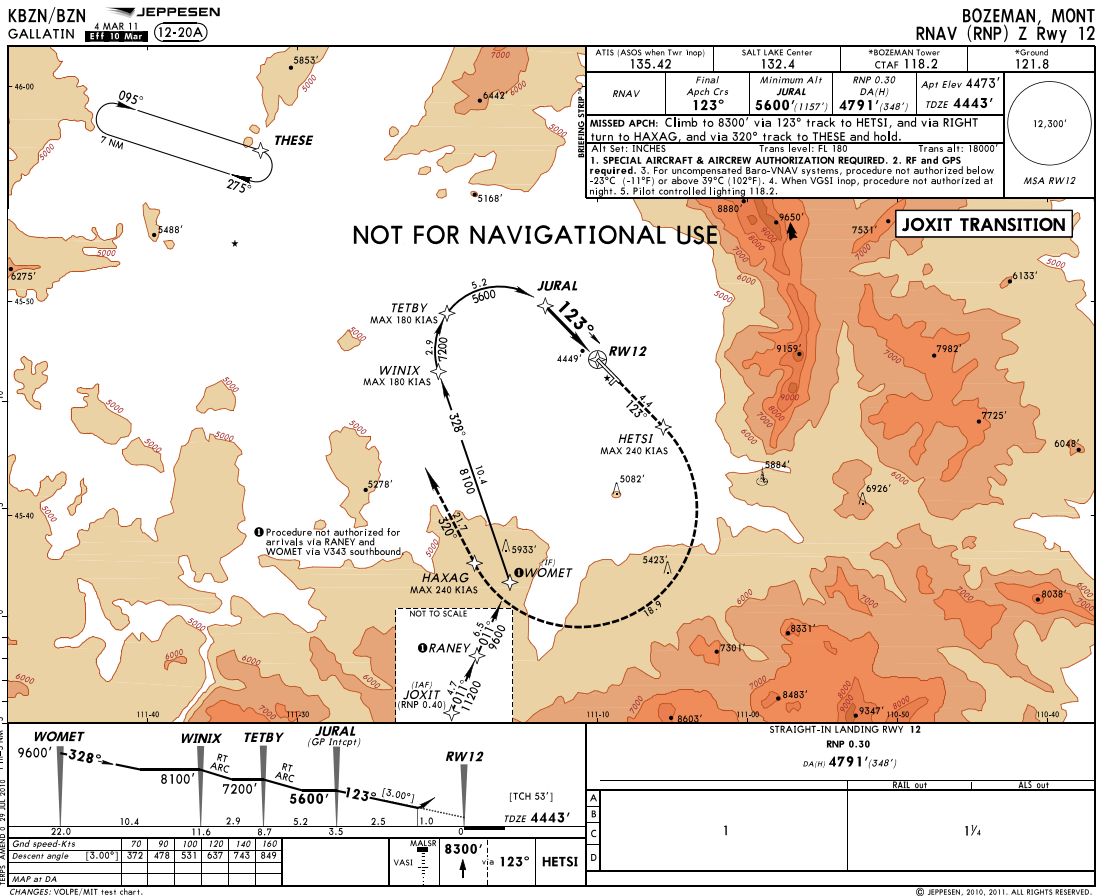

Reproduced with permission of Jeppesen Sanderson, Inc. NOT FOR NAVIGATIONAL USE
 Jeppesen Sanderson, Inc. Copyright © 2011
 Figure reduced for illustrative purposes only

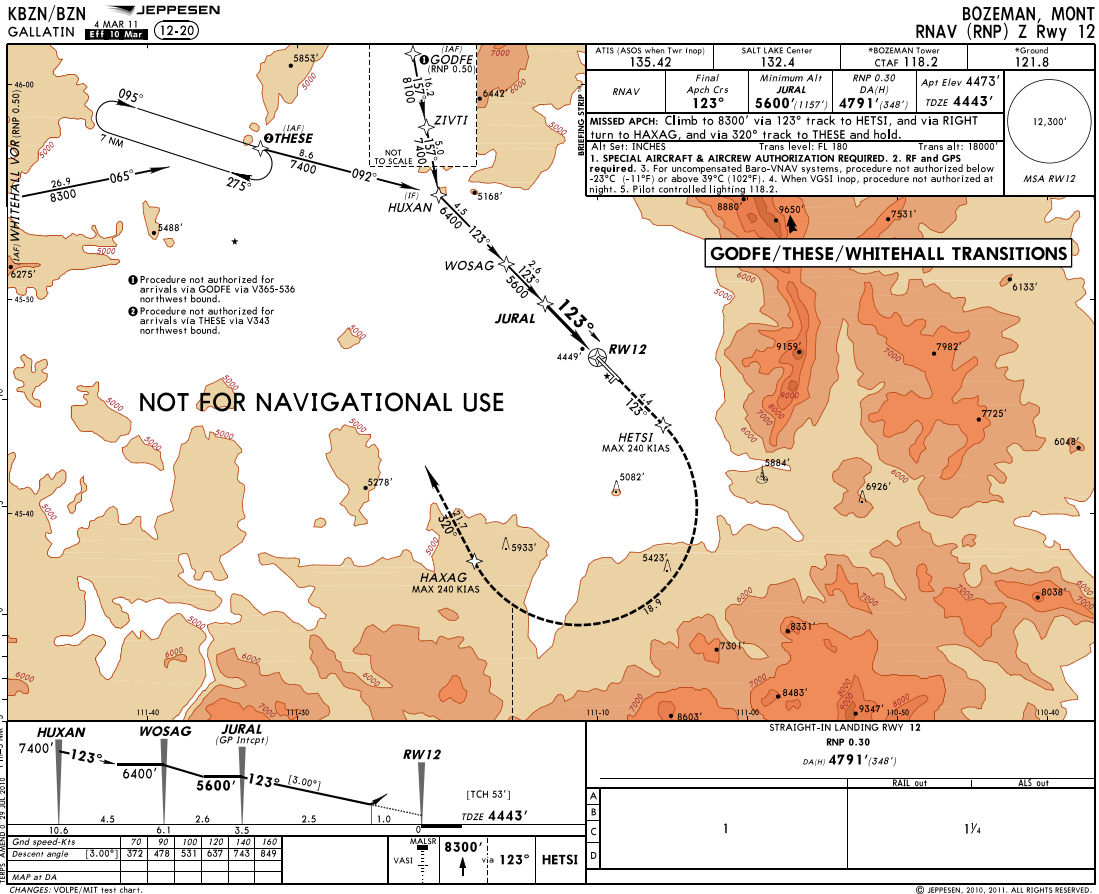

Reproduced with permission of Jeppesen Sanderson, Inc. NOT FOR NAVIGATIONAL USE
 Jeppesen Sanderson, Inc. Copyright © 2011
 Figure reduced for illustrative purposes only

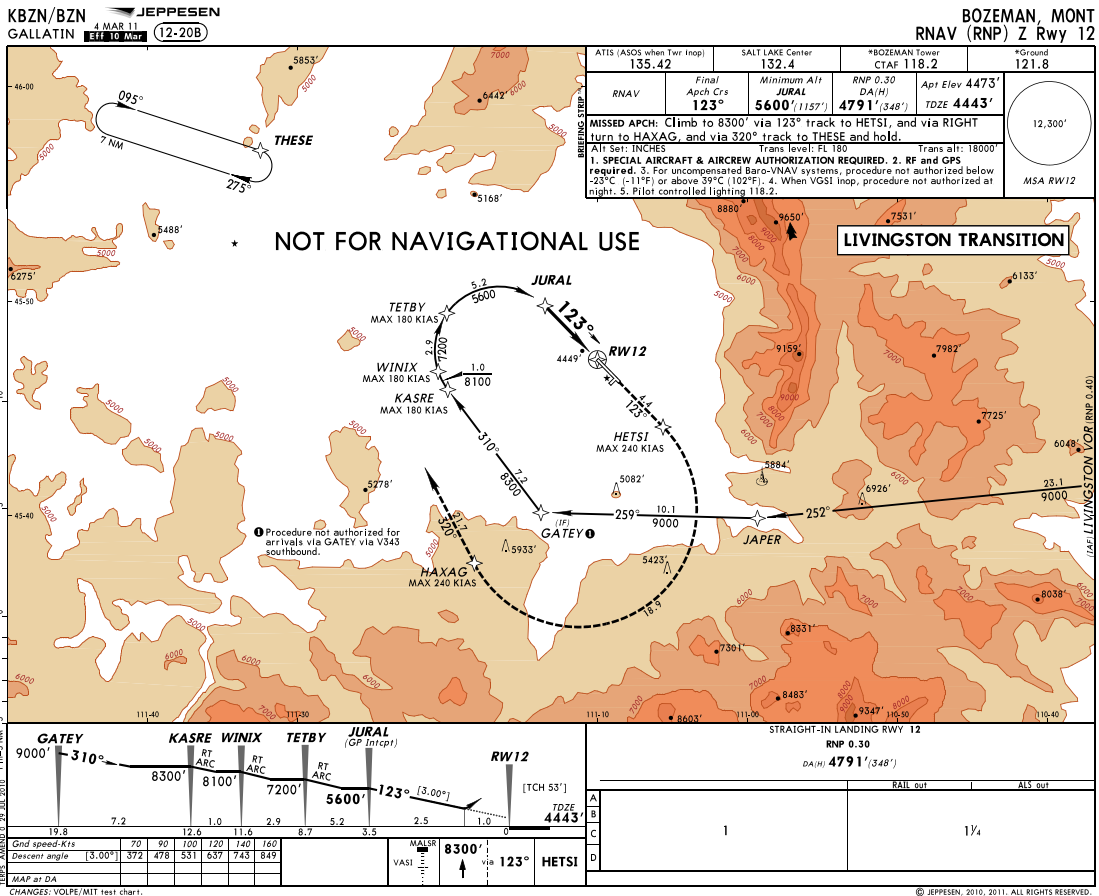

Reproduced with permission of Jeppesen Sanderson, Inc. NOT FOR NAVIGATIONAL USE
 Jeppesen Sanderson, Inc. Copyright © 2011
 Figure reduced for illustrative purposes only

KPSP/PSP PALM SPRINGS INTL **JEPPESEN** **PALM SPRINGS, CALIF**
RNAV (RNP) Y Rwy 31L

ATIS (ASOS when Twr Inop)	*SOCAL Approach (R)	LOS ANGELES Center (R)	*PALM SPRINGS Tower	*Ground
118.25	West-North 126.7	Northeast-Southwest 135.27	128.15 when App Inop.	CTAF 119.7
RNAV	Final Apch Crs 309°	Minimum Alt JISOP 2900' (2470')	RNP 0.30 DA(H) 734' (304')	Apt Elev 477' TDZE 430'
MISSED APCH: Climb to 1800', then climbing RIGHT turn to 4000' direct TRM VOR and hold. Missed approach requires minimum climb of 340'/NM to 3000'.				12,700'
Alt Set: INCHES Trans level: FL 180 Trans alt: 18000' 1. SPECIAL AIRCRAFT & AIRCREW AUTHORIZATION REQUIRED. 2. GPS required. 3. For uncompensated Baro-VNAV systems, procedure not authorized below 2°C (35°F) or above 38°C (102°F). 4. Procedure not authorized when control tower closed. 5. Visibility reduction by helicopters not authorized. 6. Final approach course offset 1.10°. 7. Pilot controlled lighting 119.7.				MSA RW31L

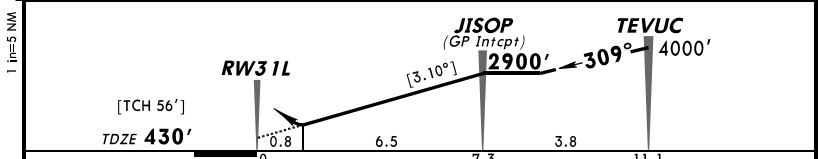
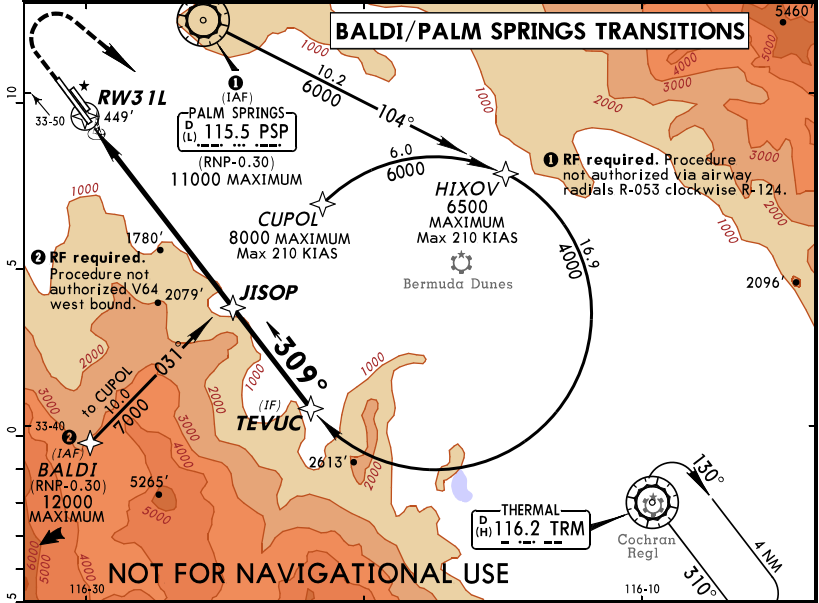

Gnd speed-Kts	70	90	100	120	140	160	REIL	1800'	4000'	TRM
Descent angle [3.10°]	384	494	548	658	768	878	VASI-L	↑	RT	116.2
MAP at DA										

STRAIGHT-IN LANDING RWY 31L
 RNP 0.30
 DA(H) 734' (304')

A	
B	
C	
D	1

CHANGES: VOLPE/MIT test chart. © JEPPESEN, 2005, 2011. ALL RIGHTS RESERVED.

Reproduced with permission of Jeppesen Sanderson, Inc. NOT FOR NAVIGATIONAL USE
 Jeppesen Sanderson, Inc. Copyright © 2011
 Figure reduced for illustrative purposes only

KPSP/PSP PALM SPRINGS INTL **JEPPESEN** **PALM SPRINGS, CALIF**
RNAV (RNP) Y Rwy 31L

ATIS (ASOS when Twr Inop)	*SOCAL Approach (R)	LOS ANGELES Center (R)	*PALM SPRINGS Tower	*Ground
118.25	West-North 126.7 Northeast-Southwest 135.27	128.15 when App Inop.	CTAF 119.7	121.9

RNAV	Final Apch Crs 309°	Minimum Alt JISOP 2900' (2470')	RNP 0.30 DA(H) 734' (304')	Apt Elev 477'	12,700'
MISSED APCH: Climb to 1800', then climbing RIGHT turn to 4000' direct TRM VOR and hold. Missed approach requires minimum climb of 340'/NM to 3000'.				TDZE 430'	

Alt Set: INCHES Trans level: FL 180 Trans alt: 18000'
1. SPECIAL AIRCRAFT & AIRCREW AUTHORIZATION REQUIRED. 2. GPS required.
 3. For uncompensated Baro-VNAV systems, procedure not authorized below 2°C (35°F) or above 38°C (102°F). 4. Procedure not authorized when control tower closed.
 5. Visibility reduction by helicopters not authorized. 6. Final approach course offset 1.10°. 7. Pilot controlled lighting 119.7.

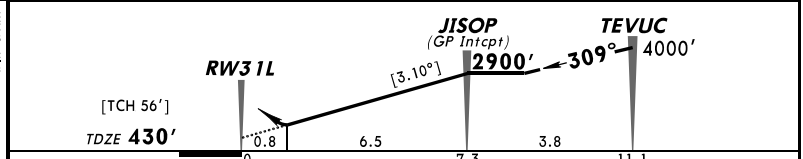
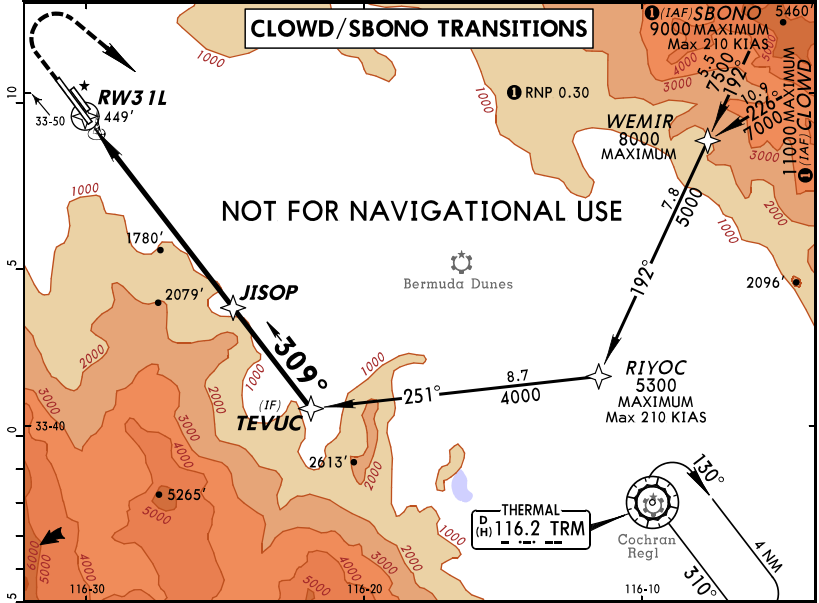

Gnd speed-Kts	70	90	100	120	140	160	REIL 1800'	VASI-L 4000'	D-TRM 116.2
Descent angle [3.10°]	384	494	548	658	768	878			
MAP at DA									

STRAIGHT-IN LANDING RWY 31L
 RNP 0.30
 DA(H) **734'** (304')

A	1
B	
C	
D	

CHANGES: VOLPE/MIT test chart. © JEPPESEN, 2005, 2011. ALL RIGHTS RESERVED.

Reproduced with permission of Jeppesen Sanderson, Inc. NOT FOR NAVIGATIONAL USE
 Jeppesen Sanderson, Inc. Copyright © 2011
 Figure reduced for illustrative purposes only

KPSP/PSP
PALM SPRINGS INTL

JEPPESEN
4 MAR 11
Eff 10 Mar (12-22B)

PALM SPRINGS, CALIF
RNAV (RNP) Y Rwy 31L

ATIS (ASOS when Twr inop)	*SOCAL Approach (R)	LOS ANGELES Center (R)	*PALM SPRINGS Tower	*Ground
118.25	West-North 126.7 Northeast-Southwest 135.27	128.15 when App Inop.	CTAF 119.7	121.9
RNAV	Final Apch Crs 309°	Minimum Alt JISOP 2900' (2470')	RNP 0.30 DA(H) 734' (304')	Apt Elev 477' TDZE 430'
MISSED APCH: Climb to 1800', then climbing RIGHT turn to 4000' direct TRM VOR and hold. Missed approach requires minimum climb of 340'/NM to 3000'. Alt Set: INCHES Trans level: FL 180 Trans alt: 18000' 1. SPECIAL AIRCRAFT & AIRCREW AUTHORIZATION REQUIRED. 2. GPS required. 3. For uncompensated Baro-VNAV systems, procedure not authorized below 2°C (35°F) or above 38°C (102°F). 4. Procedure not authorized when control tower closed. 5. Visibility reduction by helicopters not authorized. 6. Final approach course offset 1.10°. 7. Pilot controlled lighting 119.7.				12,700' MSA RW31L

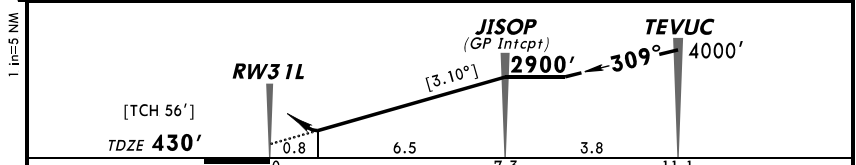
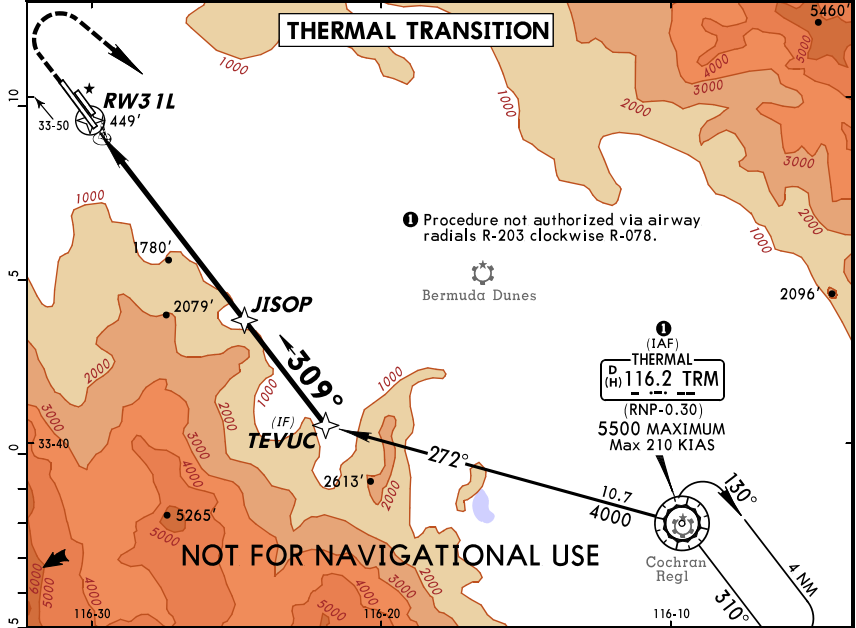

Gnd speed-Kts	70	90	100	120	140	160	REIL	1800'	4000'	TRM
Descent angle [3.10°]	384	494	548	658	768	878	VASI-L	↑	RT	116.2
MAP at DA										

STRAIGHT-IN LANDING RWY 31L										
RNP 0.30										
DA(H) 734' (304')										
A										
B										
C										
D	1									

CHANGES: VOLPE/MIT test chart. © JEPPESEN, 2005, 2011. ALL RIGHTS RESERVED.

Reproduced with permission of Jeppesen Sanderson, Inc. NOT FOR NAVIGATIONAL USE
Jeppesen Sanderson, Inc. Copyright © 2011
Figure reduced for illustrative purposes only

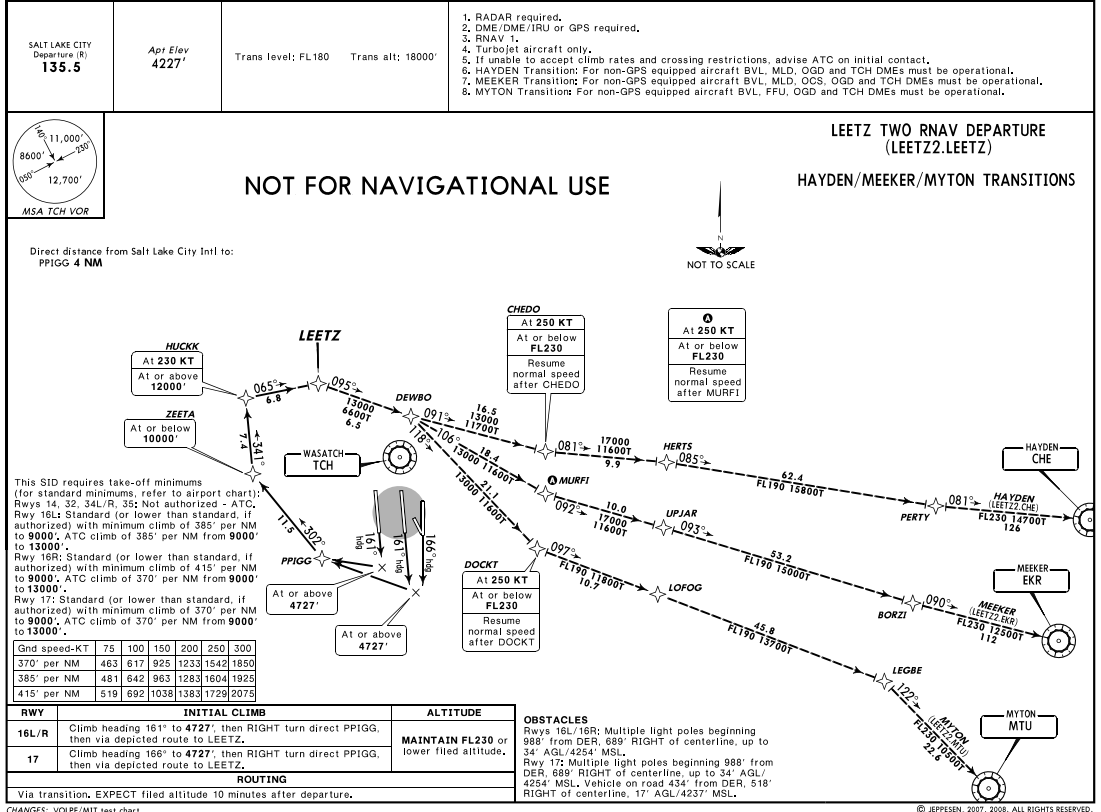

Reproduced with permission of Jeppesen Sanderson, Inc. NOT FOR NAVIGATIONAL USE
 Jeppesen Sanderson, Inc. Copyright © 2011
 Figure reduced for illustrative purposes only

KSLC/SLC
SALT LAKE CITY INTL

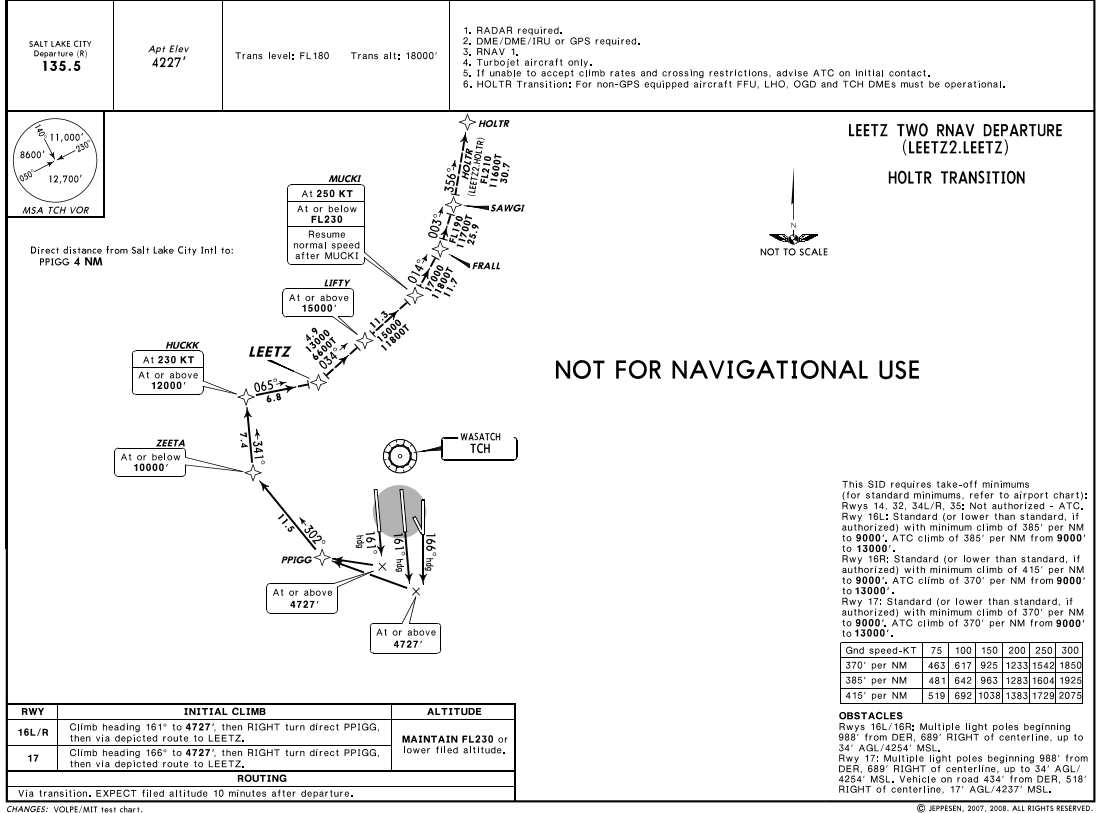

Reproduced with permission of Jeppesen Sanderson, Inc. NOT FOR NAVIGATIONAL USE
Jeppesen Sanderson, Inc. Copyright © 2011
Figure reduced for illustrative purposes only

SALT LAKE CITY Departure (R) 135.5	Apr Elev 4227'	Trans level: FL180 Trans alt: 18000'	1. RADAR required. 2. DME/DME/IRU or GPS required. 3. RNAV 1. 4. Turbojet aircraft only. 5. If unable to accept climb rates and crossing restrictions, advise ATC on initial contact. 6. ROCK SPRINGS Transition: For non-GPS equipped aircraft OGD and TCH DMEs must be operational.
---	--------------------------	--------------------------------------	--

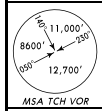

NOT FOR NAVIGATIONAL USE

LEETZ TWO RNAV DEPARTURE
(LEETZ2.LEETZ)
ROCK SPRINGS TRANSITION

Direct distance from Salt Lake City Intl to:
PPIGG 4 NM

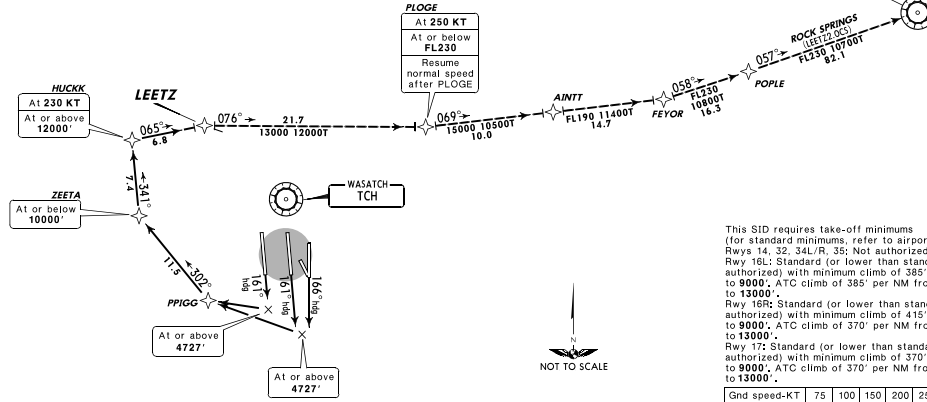

This SID requires take-off minimums (for standard minimums, refer to airport chart):
Rwys 14, 32, 34L/R, 35: Not authorized - ATC.
Rwy 16L: Standard (or lower than standard, if authorized) with minimum climb of 385' per NM to 9000'. ATC climb of 385' per NM from 9000' to 13000'.
Rwy 16R: Standard (or lower than standard, if authorized) with minimum climb of 415' per NM to 9000'. ATC climb of 370' per NM from 9000' to 13000'.
Rwy 17: Standard (or lower than standard, if authorized) with minimum climb of 370' per NM from 9000' to 13000'.
Gnd speed-KT 75 100 150 200 250 300
370' per NM 463 617 925 1233 1642 1850
385' per NM 481 642 963 1283 1604 1925
415' per NM 519 692 1038 1383 1729 2075

RWY	INITIAL CLIMB	ALTITUDE
16L/R	Climb heading 161° to 4727', then RIGHT turn direct PPIGG, then via depicted route to LEETZ.	MAINTAIN FL230 or lower filed altitude.
17	Climb heading 166° to 4727', then RIGHT turn direct PPIGG, then via depicted route to LEETZ.	
ROUTING		
Via transition, EXPECT filed altitude 10 minutes after departure.		

CHANGES: VOLPE/MIT test chart.

© JEPPesen, 2007, 2008. ALL RIGHTS RESERVED.

Reproduced with permission of Jeppesen Sanderson, Inc. NOT FOR NAVIGATIONAL USE
Jeppesen Sanderson, Inc. Copyright © 2011
Figure reduced for illustrative purposes only

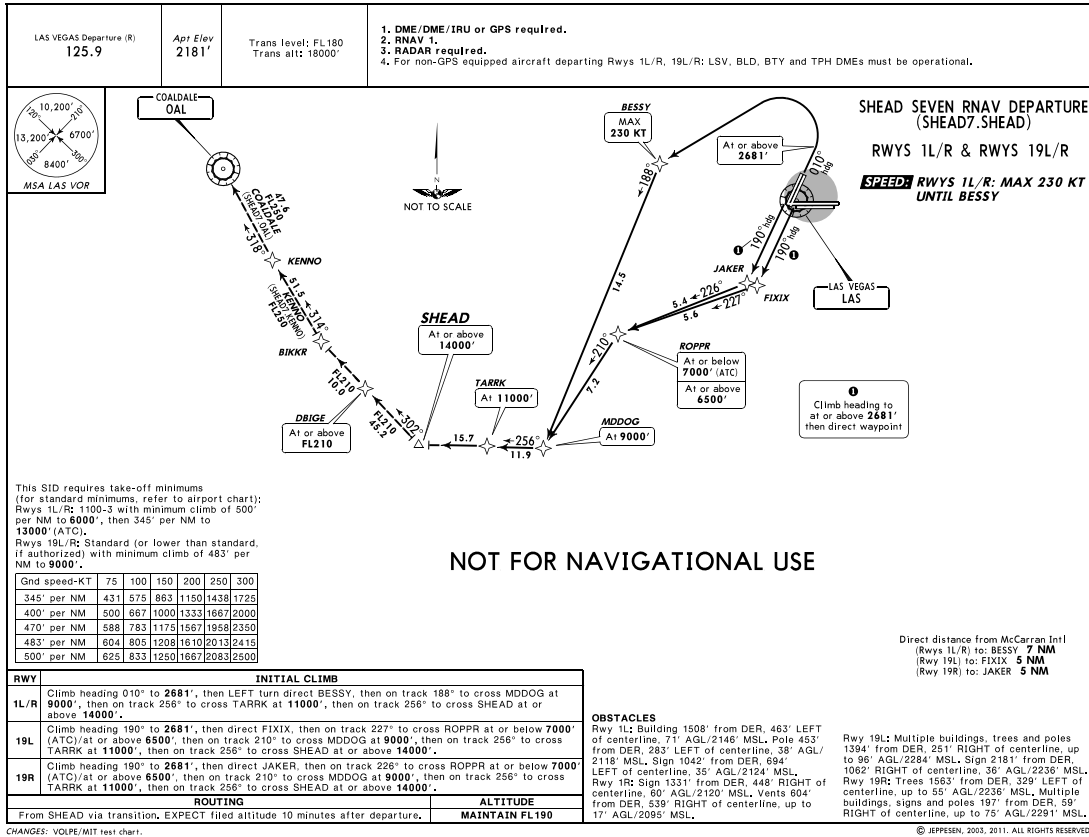

This SID requires take-off minimums (for standard minimums, refer to airport chart):
Rwys 1L/R: 1100-3 with minimum climb of 500' per NM to 6000', then 345' per NM to 13000' (ATC).
Rwys 19L/R: Standard (or lower than standard, if authorized) with minimum climb of 483' per NM to 9000'.

Gnd speed-KT	75	100	150	200	250	300
345' per NM	431	575	863	1150	1438	1725
400' per NM	500	667	1000	1333	1667	2000
470' per NM	588	783	1173	1567	1958	2350
483' per NM	604	805	1208	1610	2013	2414
500' per NM	625	833	1250	1667	2083	2500

RWY	INITIAL CLIMB
1L/R	Climb heading 010° to 2681', then LEFT turn direct BESSY, then on track 188° to cross MDDOG at 9000', then on track 256° to cross TARRK at 11000', then on track 256° to cross SHEAD at or above 14000'.
19L	Climb heading 190° to 2681', then direct FIXIX, then on track 227° to cross ROPPR at or below 7000' (ATC) at or above 6500', then on track 210° to cross MDDOG at 9000', then on track 256° to cross TARRK at 11000', then on track 256° to cross SHEAD at or above 14000'.
19R	Climb heading 190° to 2681', then direct JAKER, then on track 226° to cross ROPPR at or below 7000' (ATC) at or above 6500', then on track 210° to cross MDDOG at 9000', then on track 256° to cross TARRK at 11000', then on track 256° to cross SHEAD at or above 14000'.
ROUTING	
From SHEAD via transition, EXPECT filed altitude 10 minutes after departure.	
ALTITUDE	
MAINTAIN FL190	

OBSTACLES

Rwy 1L: Building 1508' from DER, 463' LEFT of centerline, 71' AGL/2146' MSL, Pole 453' from DER, 285' LEFT of centerline, 35' AGL/2118' MSL, Sign 1042' from DER, 694' LEFT of centerline, 35' AGL/2124' MSL.
Rwy 19L: Sign 1331' from DER, 448' RIGHT of centerline, 60' AGL/2120' MSL, Vents 604' from DER, 539' RIGHT of centerline, up to 17' AGL/2095' MSL.

Rwy 19R: Multiple buildings, trees and poles 1394' from DER, 251' RIGHT of centerline, up to 96' AGL/2284' MSL, Sign 2181' from DER, 1062' RIGHT of centerline, 36' AGL/2236' MSL.
Rwy 19R: Trees 1563' from DER, 329' LEFT of centerline, up to 55' AGL/2236' MSL, Multiple buildings, signs and poles 197' from DER, 59' RIGHT of centerline, up to 75' AGL/2291' MSL.

Reproduced with permission of Jeppesen Sanderson, Inc. NOT FOR NAVIGATIONAL USE
Jeppesen Sanderson, Inc. Copyright © 2011
Figure reduced for illustrative purposes only

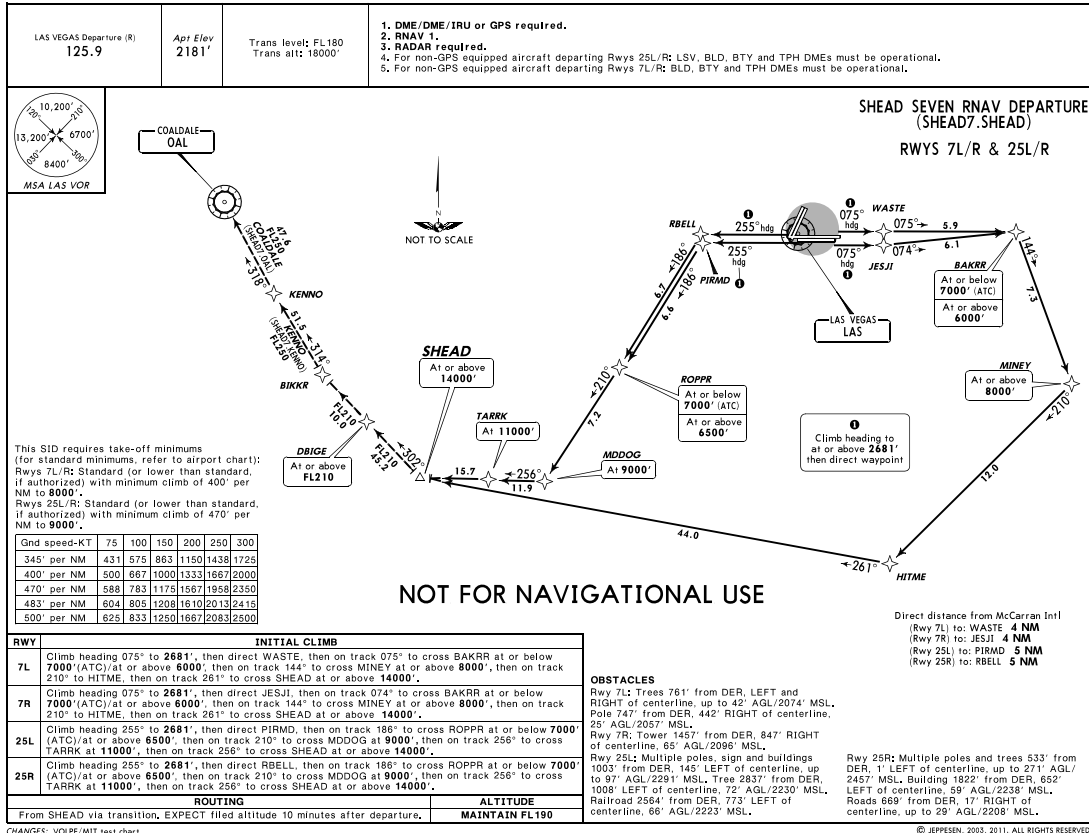

Reproduced with permission of Jeppesen Sanderson, Inc. NOT FOR NAVIGATIONAL USE
 Jeppesen Sanderson, Inc. Copyright © 2011
 Figure reduced for illustrative purposes only

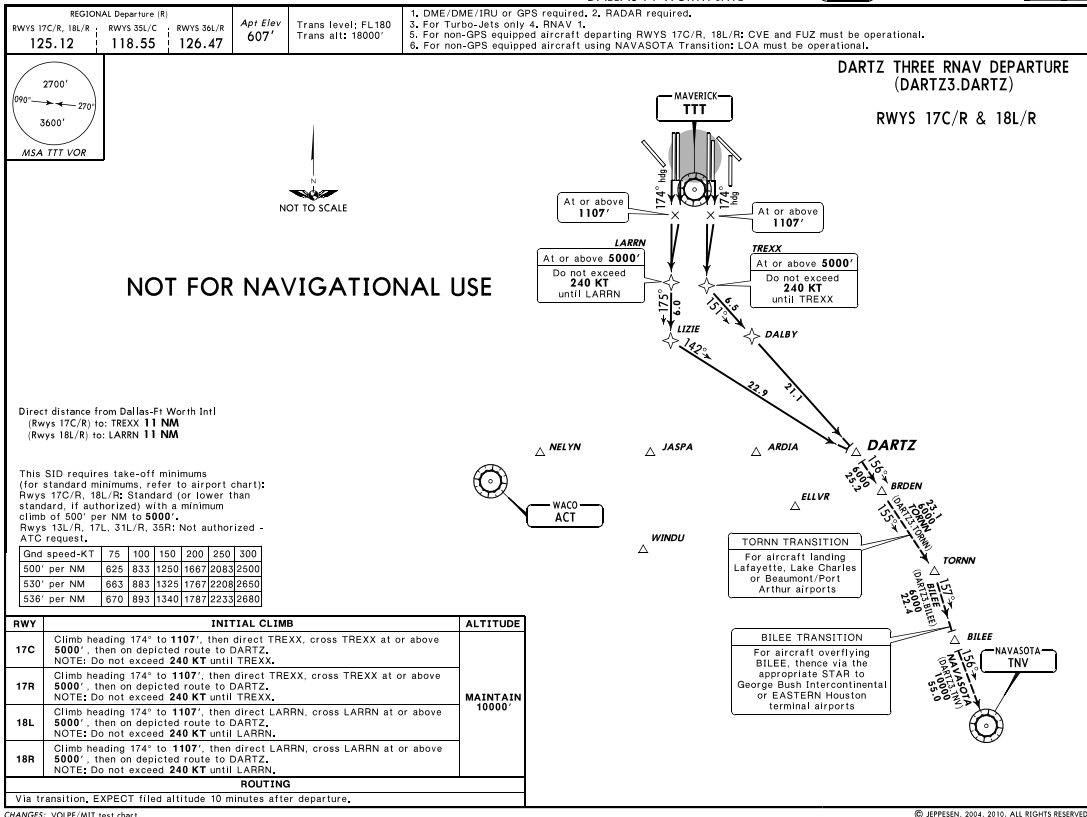

Reproduced with permission of Jeppesen Sanderson, Inc. NOT FOR NAVIGATIONAL USE
Jeppesen Sanderson, Inc. Copyright © 2011
Figure reduced for illustrative purposes only

KDFW/DFW
DALLAS-FORT WORTH INTL

JEPPESEN
2 APR 10 (60-3G-2) EFF 8 APR

DALLAS-FORT WORTH,
TEXAS
RNAV SID

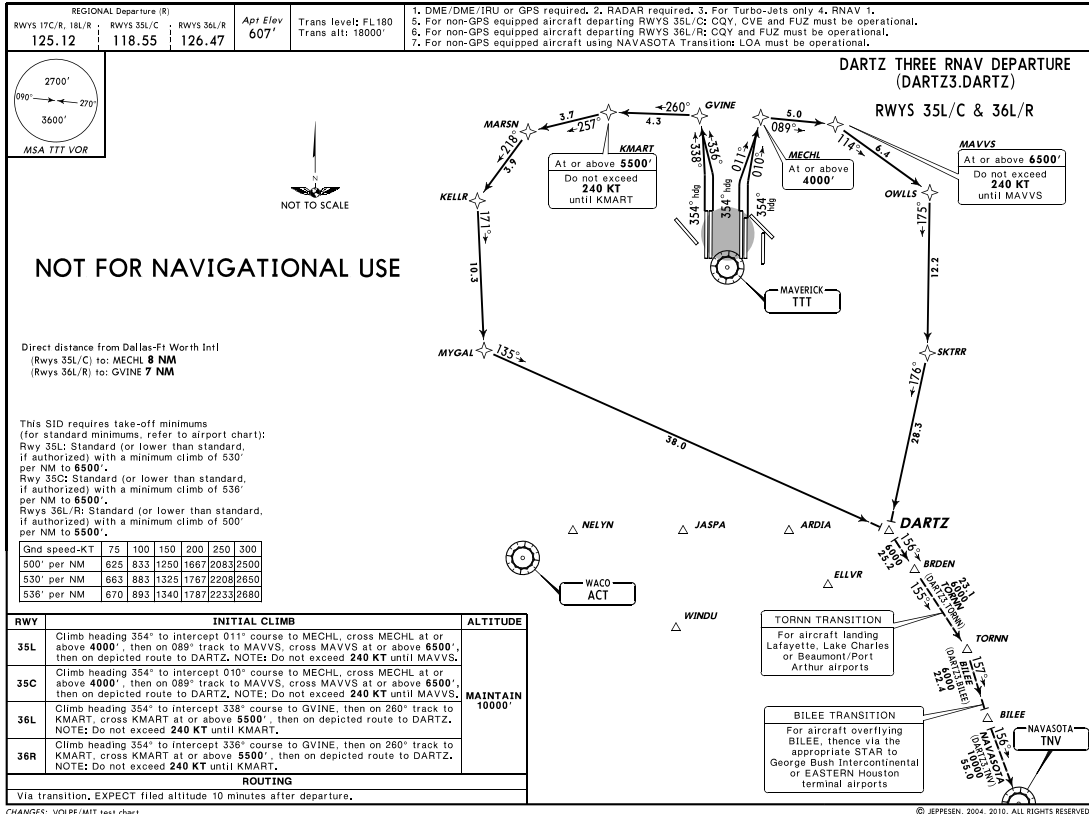

Reproduced with permission of Jeppesen Sanderson, Inc. NOT FOR NAVIGATIONAL USE
Jeppesen Sanderson, Inc. Copyright © 2011
Figure reduced for illustrative purposes only