

LIVABILITY AND VARIFORMITY: A STUDY OF A
CONCRETE COMPONENT SYSTEM FOR HOUSING

By

Loren Ahles

B.E.D., University of Minnesota, 1974
B. Arch., University of Minnesota, 1975

Submitted in Partial Fulfillment of
the Requirements of the Degree of
Master of Architecture, Advanced Studies

Massachusetts Institute of Technology
June, 1977

AUTHOR _____
Department of Architecture
12 May, 1977

CERTIFIED _____
Eduardo Catalano
Professor of Architecture
Thesis Advisor

ACCEPTED _____
Eduardo Catalano, Chairman
Departmental Committee
on Graduate Students



12 May, 1977

Dean William Porter
School of Architecture and Planning
Massachusetts Institute of Technology
77 Massachusetts Avenue
Cambridge, Massachusetts

Dear Dean Porter:

In partial fulfillment of the requirements
for the degree of Master of Architecture,
Advanced Studies, I hereby submit this
thesis entitled:

**LIVABILITY AND VARIFORMITY: A STUDY OF A
CONCRETE COMPONENT SYSTEM FOR HOUSING**

Respectfully,

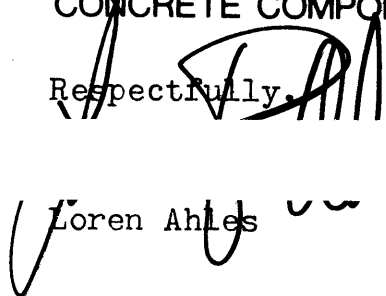
Loren Ahles

LETTER OF SUBMITTAL

I would like to thank these people who
contributed much to make this thesis
possible:

Eduardo Catalano
Professor of Architecture
Thesis Advisor
Massachusetts Institute of Technology

Peter Blewett
Graduate Student
Massachusetts Institute of Technology

Merle Hansen
Graduate Student
Massachusetts Institute of Technology

Martha Yunker
Architect

ACKNOWLEDGEMENTS

LIVABILITY AND VARIFORMITY: A STUDY OF A CONCRETE COMPONENT SYSTEM FOR HOUSING

Loren Ahles

Submitted to the Department of Architecture on 12 May, 1977, in partial fulfillment of the requirements for the degree of Master of Architecture, Advanced Studies.

This thesis is an investigation of a housing system comprised of industrially produced, precast concrete, structural components arranged in non-orthogonal geometric configurations producing variety and freedom of personal living space. It attempts to study the possibilities and limitations in the use of currently produced structural components and existing living patterns when applied to a non-orthogonal building geometry.

The thesis consists of four main parts: The first is a general investigation relating to qualitative guidelines for the design of housing environments. The second is a proposal of non-orthogonal living spaces as a variation from the constant similarity within contemporary housing environments. The third is a study of the use of standardized precast concrete components so as to take advantage of their capabilities and to propose a new direction for their use. The fourth is the application of the structural concept in a design for housing, demonstrated by interior unit planning and building configurations.

Part one presents qualitative guidelines as a means of formulating and evaluating housing design. These guidelines are represented as housing rights and apply to the individual dwelling unit, the unit cluster and the neighborhood complex.

Part two deals with geometries generated by using a two-directional framing system and diagonal bearing surfaces. Graphic explanation of the geometry, the resultant geometric shapes and the range of sizes allowed by the geometry are shown.

Part three is concerned with the use of precast, hollow core, concrete planks. The manufacturing, transportation and erection processes are presented. There is a comparison of current plank production models and a demonstration of angular end cutting for cored planks. Framing variations with structural components, structural details for the precast system and bearing wall post-tensioning are demonstrated.

Part four is a demonstration of the design proposal. Support systems such as HVAC, plumbing and electrical distribution are included. Unit planning and building morphology comprise the major portion of this section. The housing system is applied to three sites for the purpose of relating site capacity to various configurations.

Thesis Advisor



Eduardo Catalano
Professor of Architecture

ABSTRACT

TITLE PAGE	1	SUBSYSTEMS	43
LETTER OF SUBMITTAL	3	Core Components	
ACKNOWLEDGEMENTS	5	Cores	
ABSTRACT	7	Exterior Spaces	
TABLE OF CONTENTS	9	Roof Sections	
INTRODUCTION	11	Bathroom Options	
PROGRAM GOALS	12	Interior Stairs	
GEOMETRIC CONCEPT	16	Exterior Infill Panels	
Area Fluctuations		Panel Variations	
Framing Variations		Partial Elevations	
Basic Geometric Shapes		UNIT PLANNING & CLUSTER MORPHOLOGY	57
STRUCTURAL SHAPES	25	Unit Area Study	
Structural Components		Unit Planning	
Plank Comparison		Unit Clustering	
Component Production		Building Morphology	
Component Transportation		SITE APPLICATION	93
Component Erection		CONCLUSIONS	101
Post-tensioning Diagram		ADVISEMENTS	103
Beam & Bearing Wall Reinforcing			
Construction Details			

CONTENTS

It is the concern in this thesis to design not only an industrialized housing system, but to design a housing system which is sensitive in variety, diversity and complexity for those who would inhabit it.

It is not enough to provide only a system, because too often in the design of systems in architecture, the system is the only goal. This attitude omits any concern for the object of its own conception. Systems cannot be thought of, or visualized as, products in themselves. Rather, a system is only a system of parts which should be used to satisfy human environmental and psychological needs. Many industrialized housing systems in the past have been created with most of their design attention directed towards perfecting the intricacies of their specific personalities, using the needs of people only as a guide. The result has been a sophisticated, precisely detailed, specialized hybrid which can exist only with a major construction effort to justify its existence economically, and with the needs of its inhabitants simply as a measure to dimension its parts. When the design of a system replaces its concern for what it can offer people, it truly becomes a machine. It is not a "machine for living" as LeCorbusier offered, but a hybrid derived from this with no similar regard for living. These systems suggest, rather, living for the sake of life in a machine.

It is my intent to organize a system of relatively small and manageable parts, adaptable not only to the requirements of human shelter, but also to the qualitative

needs of human existence. The production of these parts should not be so specialized as to restrict the location of their use or to require a tremendous volume to achieve economic feasibility. The number of parts should be finite to the extent of being naive and offer, or allow, a wide range of possibilities in their organization. The individual parts should be simple in shape and in assembly, but offer durability and permanence in use. The organization of these parts should be systematic and repetitive, but not so obviously predictable as to limit its application. The system of parts should not exclude the acceptance and incorporation of other suitable solutions within the scope of the total design. The organization of the parts should offer an alternative to the standard orthogonal geometries, but maintain organization and efficiency within the dwelling unit. It is not implied that rectilinear schemes are not successful, instead, that there are variations in geometry which need to be investigated and evaluated with respect to their appropriateness as a dwelling environment. The goals of non-orthogonal geometries are to provide fluidity in building shapes, flexibility in cluster formation and adaptation to various site limitations.

It is not my intention to promote the context of this thesis as the new answer to housing organization, but only to present it as a serious exploration into a different solution for economical, humane, housing environments.

INTRODUCTION

In any housing design there are a great number of guidelines and regulations which influence the design development. The documented regulations available are building codes, fire codes, health and safety regulations, minimum space standards and zoning ordinances. All of these regulations address themselves to a quantitative analysis of housing and seem to have very little impact on the quality of the living environment. As a result these guidelines receive much attention while little is paid the needs and aspirations of the people who must live within the smallest rooms and cheapest walls and walk along the narrowest possible hallways.

It is no surprise that building codes have tried to document and organize the tangible, quantitative aspects of real structures. It is easier to agree on a set of minimum areas, fire ratings or plumbing requirements than it is to define the qualities which compose a physically and emotionally satisfying place to live. These quality relationships have to do with privacy, identity, growth, spaciousness, belonging and security. There must be a new form of code which addresses these quality relationships. Such a code would supplement and balance the quantitative regulations.

It has been proven that physical form and organization have a tremendous effect on personal behavior and social well-being. Quantitative guidelines have little or no

effect on personal behavior or social well-being. In order to obtain a certain level of satisfaction and livability within a dwelling environment, one must rely on documented and proven patterns composing the socio-physical environment. These patterns must be understood in physical terms having environmental consequences, but they should not relate specific minimum dimensions, volumes, material qualities or locations. However, they do describe, visualize and define characteristics of a design which are so basic that to exclude their consideration would lower the quality of living within the dwelling and in the local environment. It may be said that a dweller has a right to quality in environment as well as safety, economy and functionality.

A set of qualitative guidelines could provide aid in many areas relating to the design, development, implementation and evaluation of housing environments. Such a set could become a checklist in the design process. It would be a means of evaluating and analyzing past solutions as a basis for renovation and rehabilitation. As with any other code or creed, the qualitative guide should be open to criticism and revision. It should be a flexible document which responds to the needs and aspirations of all people, a performance standard based on the demands of human nature.

PROGRAM GOALS

INDIVIDUAL UNITS

- The interior and exterior of a new building should reflect the cultural values and the living patterns of prospective residents.₄
- The size of the dwelling unit should be determined by the total basic requirements for each individual family.₄
- The minimum dwelling unit should be designed so it can be continuously upgraded and enlarged.₄
- The territory of the dwelling unit should be clearly distinct from public spaces.₄
- In mid and highrise buildings, each unit should be distinguishable and comprehensible from the exterior and from interior circulation.₄
- The dwelling units should provide an emphasis on personality, individuality and changeability within its boundaries.₂
- The dwelling unit should be open to air and view in at least two directions, to permit light and natural ventilation in a majority of habitable spaces.₄
- There should be direct access to private, furnishable outdoor garden, court, terrace, balcony or roof space open to the sky.₄
- The entrance to the dwelling should have a sense of gateway.₄
- The units should be designed to minimize dependence on mechanical climate control.₄
- The sizes of rooms and spaces within the unit should not limit their use to one specific activity.₉
- The rooms and spaces need not be neutral in terms of form, but should be perceived as simple volumes.₉
- The doors, windows and other elements should be placed to afford variety in room use.₉
- The unit plan should allow different functions to be allocated to different spaces or locations.₉
- The kitchen should be of adequate size to allow for the addition of other utility equipment.₉
- Unit planning should reflect variety and ease of interconnection between spaces.₉
- Unit planning should provide adequate division or separation between activities.₉
- Rooms and spaces should be large enough to allow freedom in furniture arrangement.₂
- Windows should be large enough to provide connection with the exterior and to allow observation from, and expression of, the individual units.₂
- Kitchen and dining spaces should be large and open enough to promote their use as a vital family space.₂

UNIT CLUSTER

- Dwellings should be organized in clusters related to the optimum grouping of residents for neighborliness and play.₄
 - Clusters should be recognizable from the exterior.₄
 - Clusters should be designed in harmony with the culture of their locality.₄
 - Clusters should be supported by communal facilities and amenities in proportion to their size and location within the neighborhood.₄
 - Entrances to clusters or groupings should provide or promote character, identity and a sense of territoriality.₄
- Clusters should not be thought of as isolated elements from the community.₄
- A cluster should provide a semi-public common space to promote dialogue between inhabitants; this common space should benefit and be protected from the prevailing climate.₄
 - Sun movement and intensity should relate directly to cluster organization.₂
 - Dwelling units within a cluster should be organized to provide changes in view and organization.₂
 - Clusters should allow varied grouping and apartment-type organization.₂
 - Storage for each unit should be provided within the cluster.₂

- Natural landscape features of the site of the cluster should generate a unique design response.₄
- Each cluster should have a comprehensible number of families, whether it is a part of a low or a high density neighborhood.₄
- Each cluster should be organized to encourage cooperation between the residents, and to foster a sense of identity and belonging for its inhabitants.₄
- Public utilities and services provided to the cluster should complement efficiently those available within the dwelling.₄

CLUSTER NEIGHBORHOOD

- The number of families living in a neighborhood may vary from 600 to 2000, representing approximately 2000 to 8000 people, depending on density, family composition and life style.₄
- The neighborhood should provide accommodation for persons and families of varied ages, incomes and social backgrounds.₄
- Resident participation in the decision-making process and in the day-to-day administration, organization and maintenance of the life activities of the neighborhood should be encouraged.₄
- The neighborhood should include sufficient mixed land uses to provide local enterprise and employment.₄
- The physical form and organization of the

neighborhood should grow from a regard for the basic life style and culture of the people.₄

- The historical uniqueness of a development site should be understood and preserved.₄
- The buildings or clusters of the neighborhood should provide individual identities as a means of giving a sense of place and orientation to inhabitants.₂
- The clusters should be enmeshed in the fabric of the neighborhood.₄
- The cluster neighborhood should capitalize on unique topographical and ecological features.₄
- Site planning should reflect informality of activity and behavior.₂
- The composition of inhabitants should be mixed with respect to income, age, race and ethnic group.₂
- The basic community facilities should be incorporated within the site, eg. shopping, child care, laundry, recreation room.₂
- Community facilities should promote expansion and interaction both day and night.₂
- Land for family gardens should be available to approximately 50% of the units.₂
- When possible, existing streets should be preserved to promote integration with surrounding communities. Likewise, entrances to and circulation through the site should promote use by inhabitants of the neighboring community.₅

- Streets, especially commercial streets, should be an important element of the site development, providing public meeting areas, promoting safety and integrating the neighborhood.₅
- Public transportation should be available within an eight minute walk from the center of the site.₂
- The site should have identifiable zones and boundaries for public, semi-public and private spaces in order to define responsibility for maintenance.₂
- The site should accept and complement the existing neighborhood in use, character and scale.₂
- Open spaces should present a hierarchy of size, scale, use and character in the site circulation.₂
- Public spaces should promote the use of planting and three-dimensional treatment of ground as buffers between activities.₂
- Direct, maintainable walks should be provided from all points of departure to all points of arrival so as to minimize disruption and damage to green areas.₂
- The low income resident should not be isolated from the rest of the community.₄

The geometric concept of the structural system is based on a two-directional, rectilinear grid. The base dimension, or module, for the grid is derived from the nominal width of the chosen floor planks. In this structural demonstration 4'-0 wide planks were chosen. Planks, bearing walls and perpendicular beams accept lengths at 4'-0 intervals. Plank ends may also be cut at 45° to the edge. This cutting produces a new diagonal module of 5'-8.

Bearing walls are located on the orthogonal grid forming a rectangular space with the corners not enclosed. Beams span between bearing wall ends at 45° completing the basic octagon shape. Planks may span in either of two directions across the octagon. Shapes of the planks may either conform to the perimeter structure, or cantilever out from the bearing wall or beam a maximum distance of 8'-0.

This organization can produce a wide variety of structural shapes, but these can be refined into a family of seven polygonal shapes, including the octagon. These shapes are derived by manipulating the length and the orientation of wall panels and beams around the basic orthogonal shape. These seven structural shapes together form the basis for particular living units.

All the shapes can fluctuate in area within the pre-determined structural limitations. They may be combined to produce variety in building morphology and adaptability in building planning.

GEOMETRIC CONCEPT

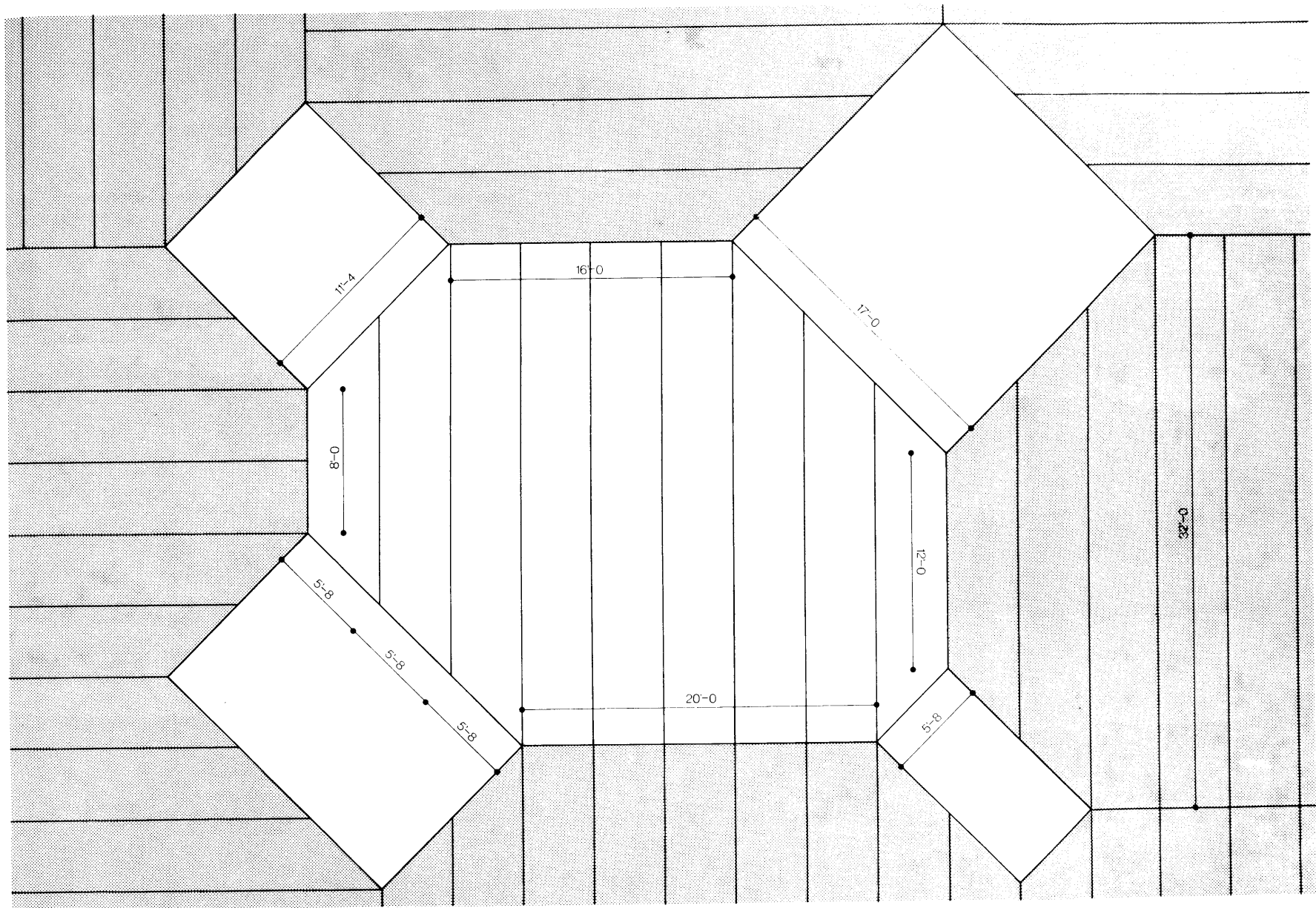

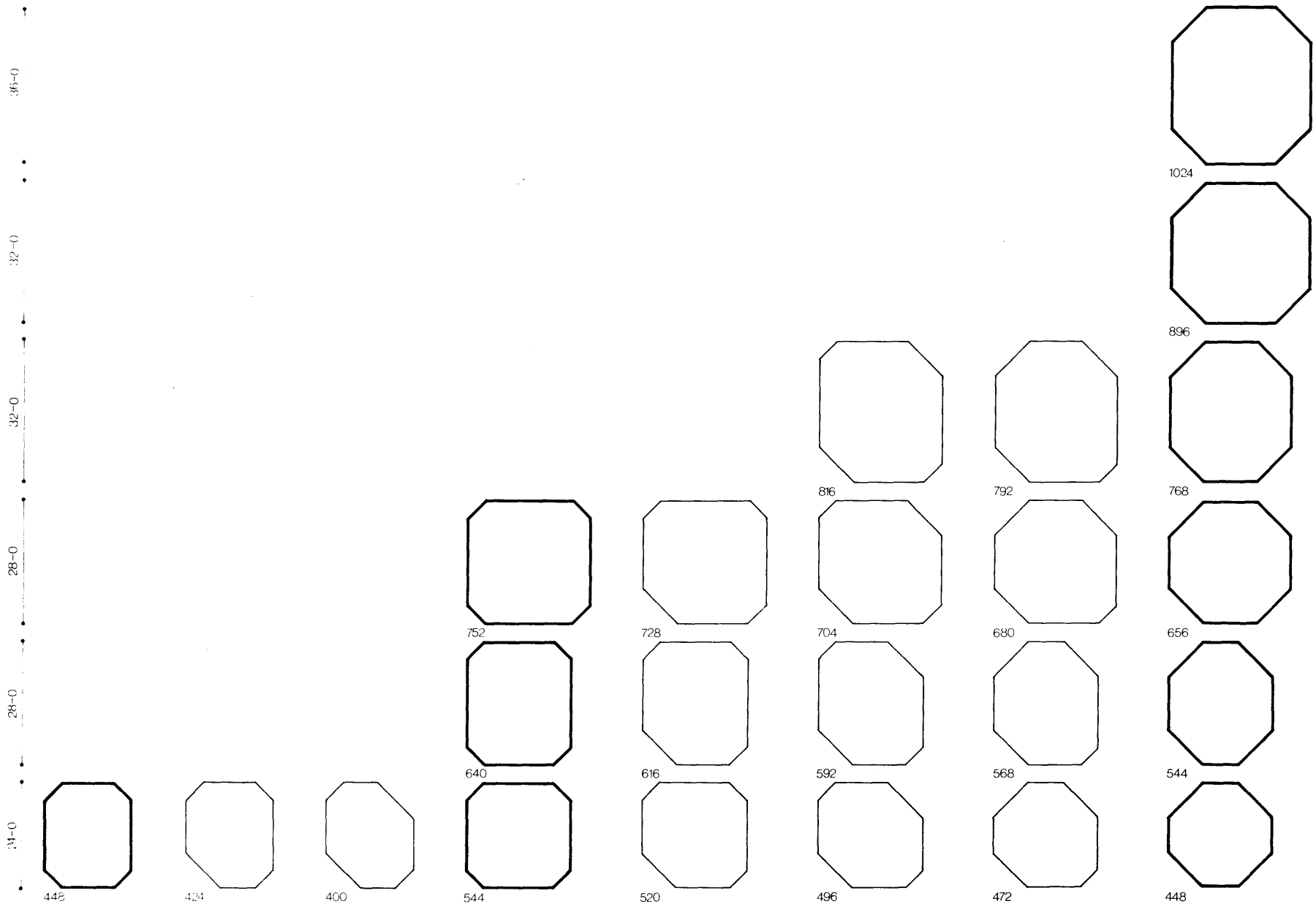

SIZE RANGE FOR OCTAGONS

AREA FLUCTUATIONS

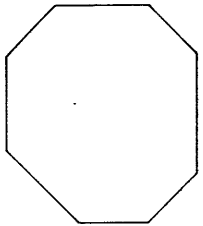

984

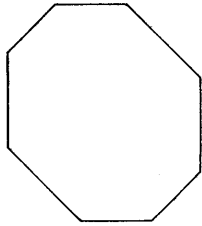

944

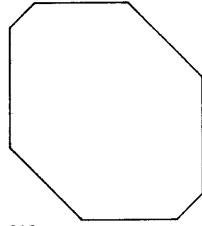

992

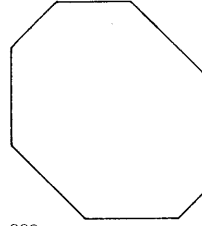

968

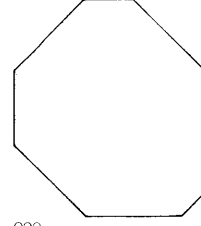

928

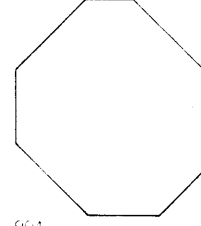

904

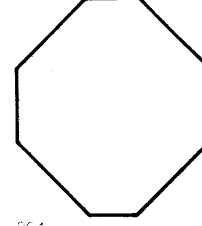

864

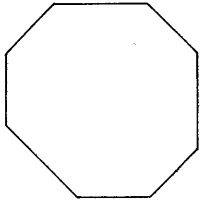

856

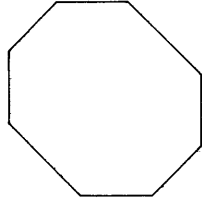

816

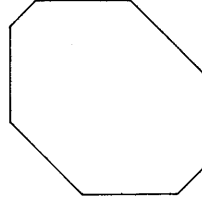

864

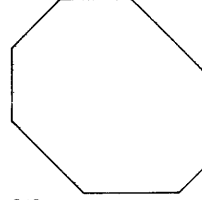

840

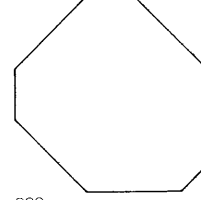

800

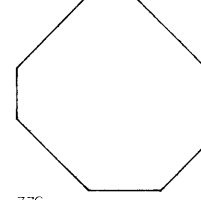

776

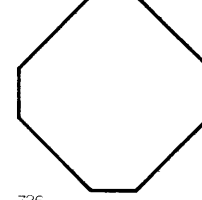

736

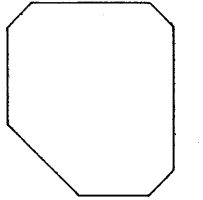

800

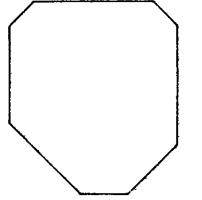

776

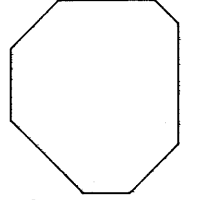

752

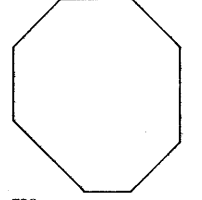

728

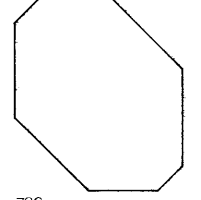

736

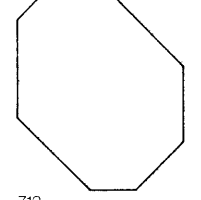

712

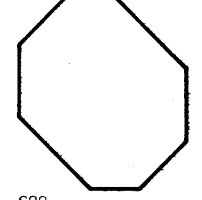

688

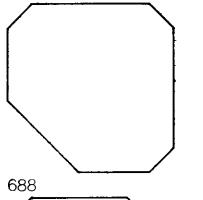

688

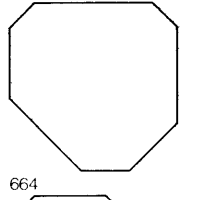

664

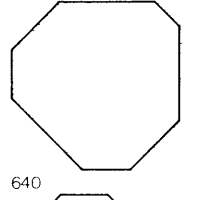

640

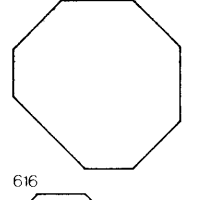

616

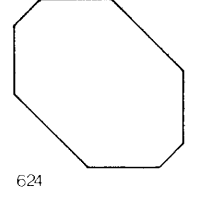

624

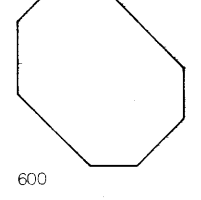

600

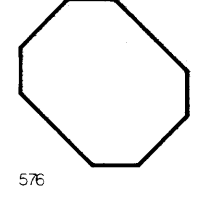

576

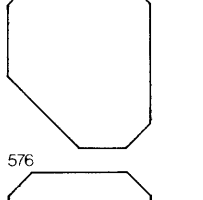

576

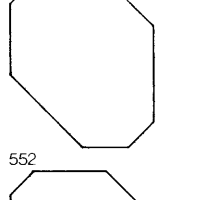

552

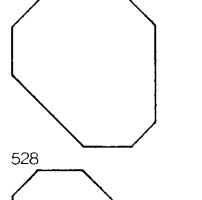

528

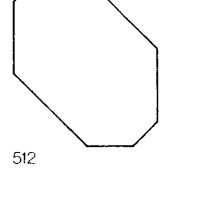

512

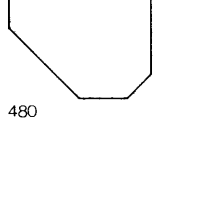

480

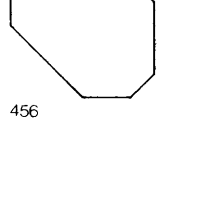

456

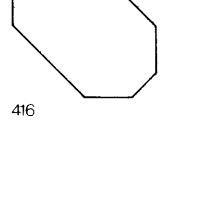

416

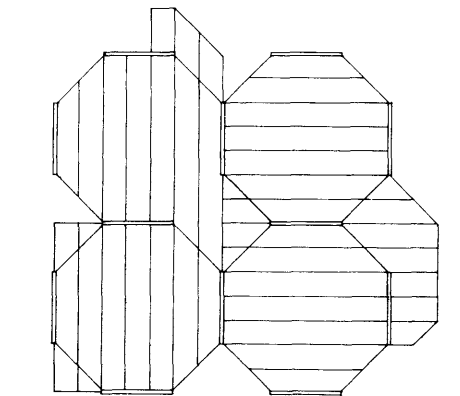
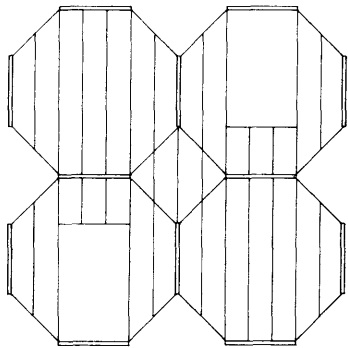
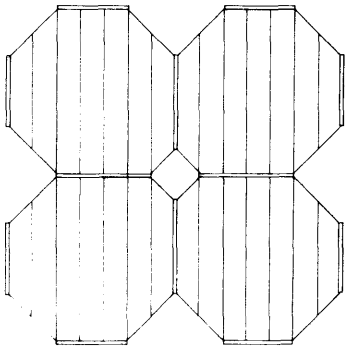
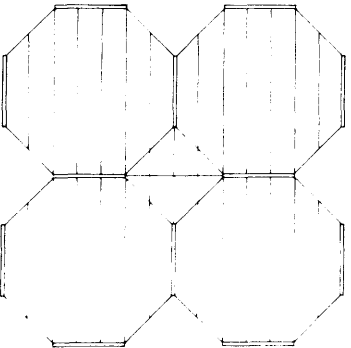
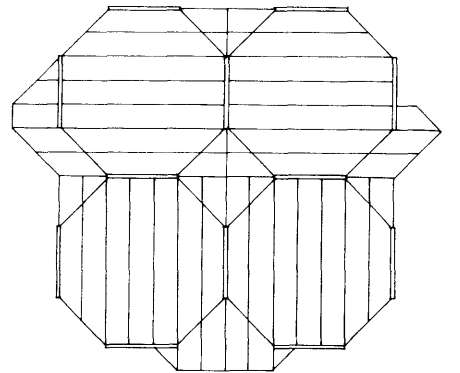
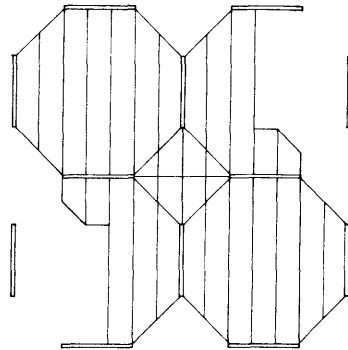
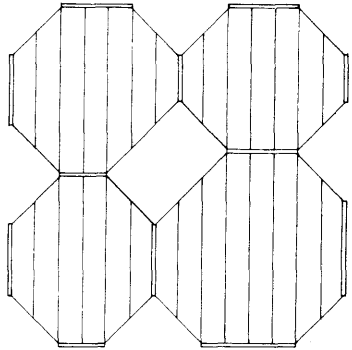
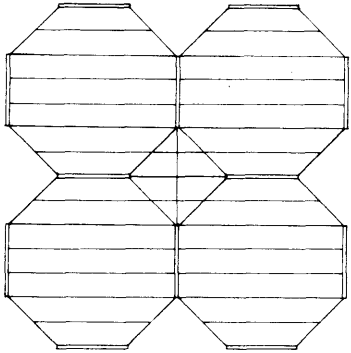
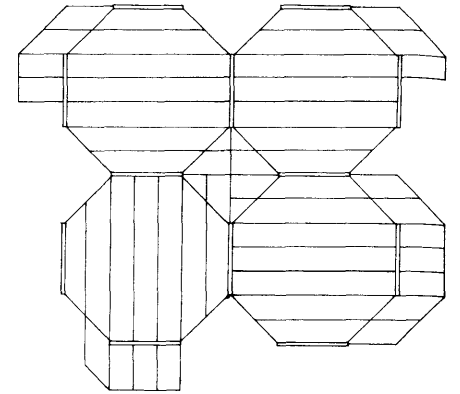
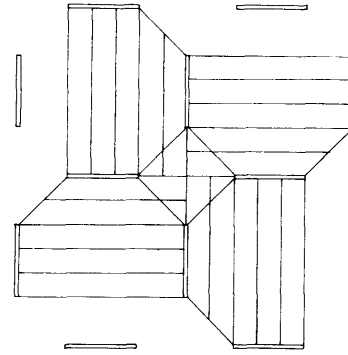
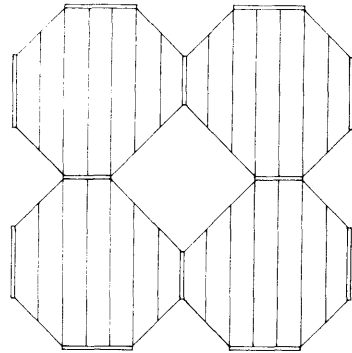
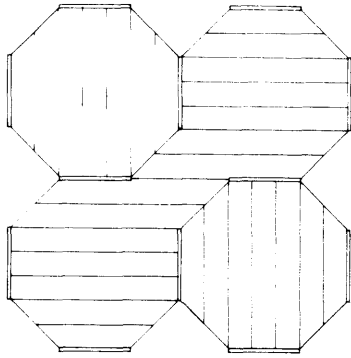

SPAN DIRECTIONS

RESULTING RECTANGLES

INTERIOR OPENINGS

CANTILEVERS

FRAMING VARIATIONS

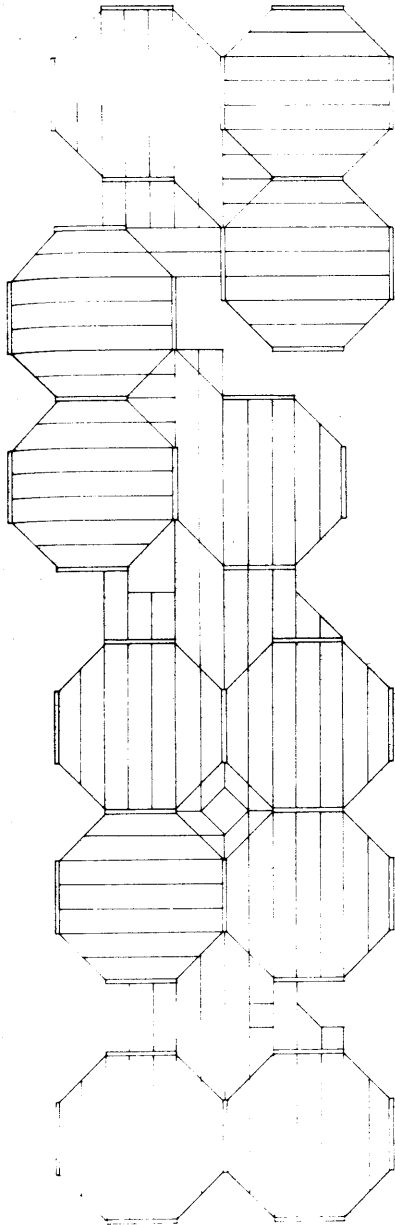

INFILL

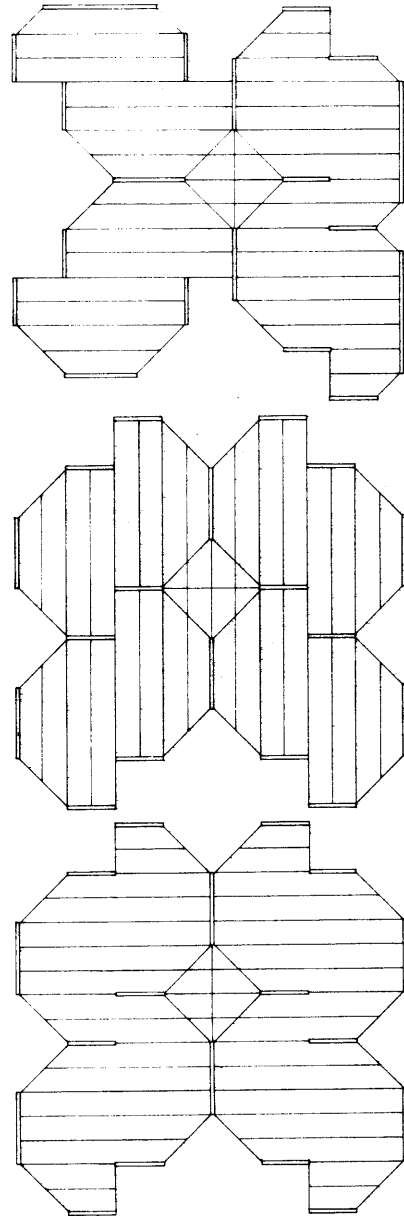

SPLIT OPTIONS

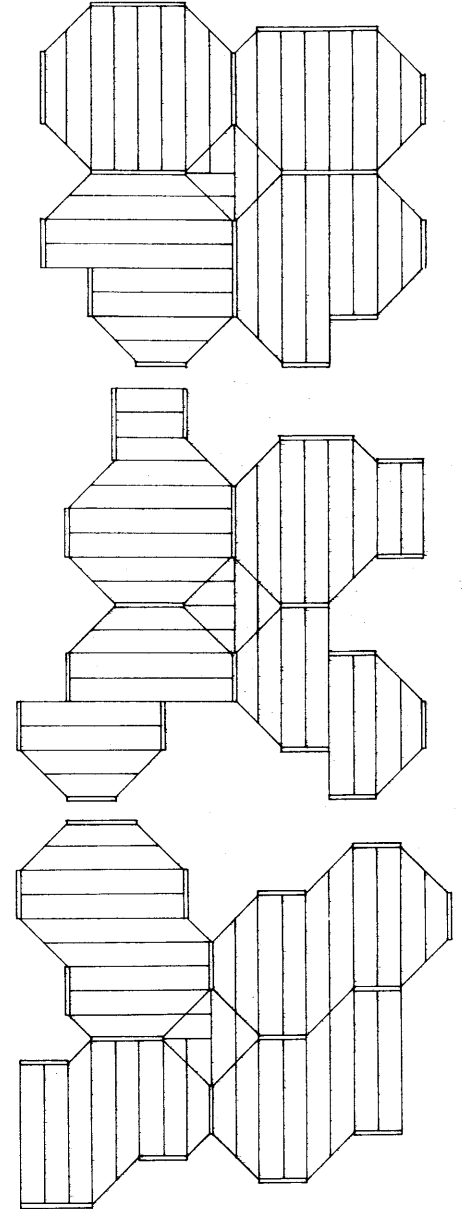
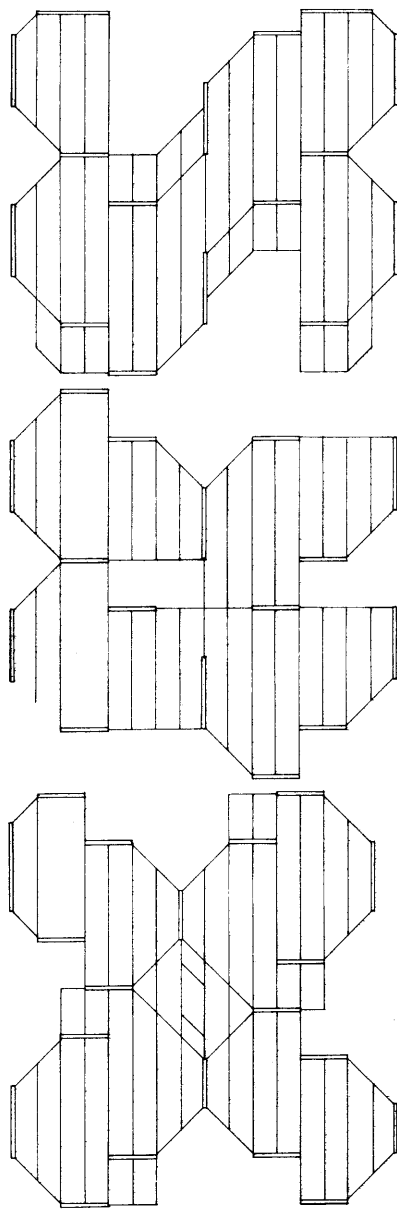

ALTERNATIVE SHAPES

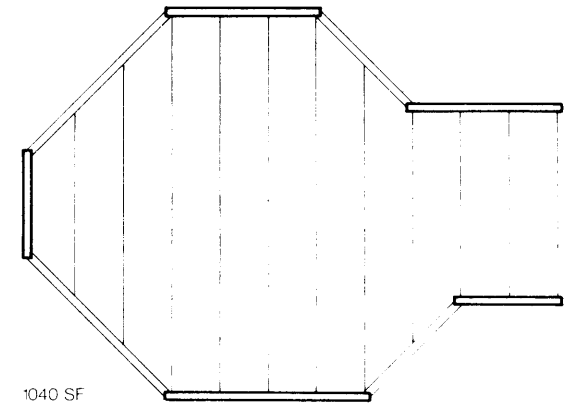
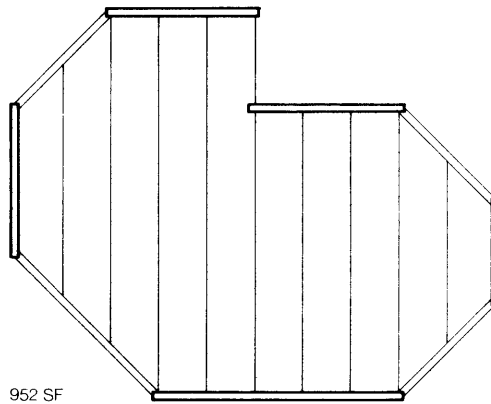
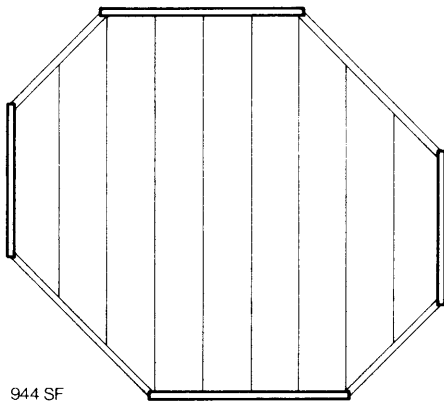
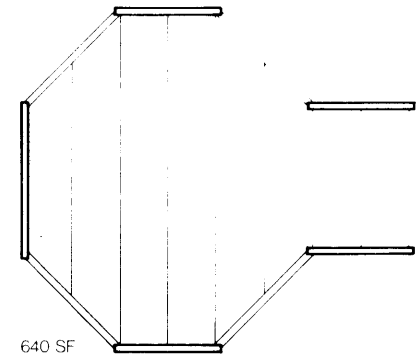
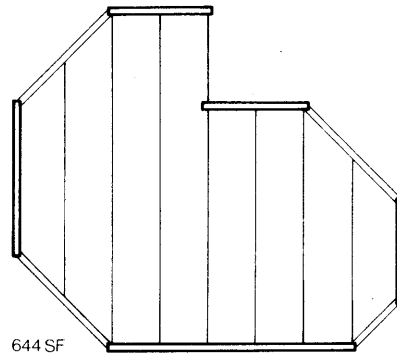
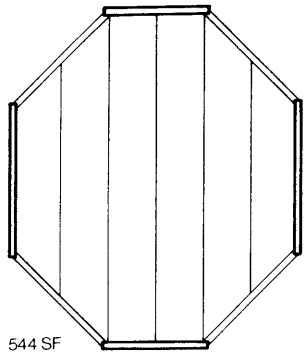

448/1024 SF

773/1221 SF

512/1216 SF

BASIC GEOMETRIC SHAPES

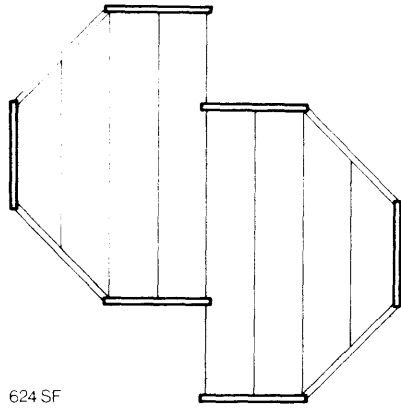

624 SF

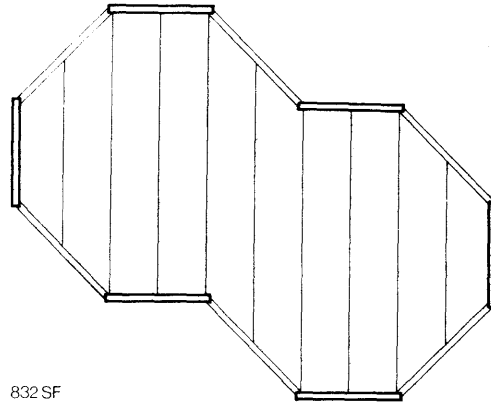

832 SF

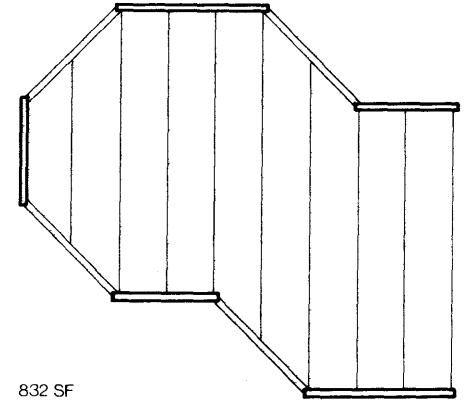

832 SF

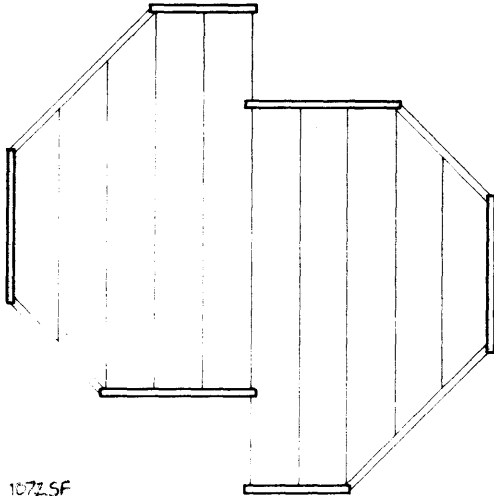

1072 SF

624 / 1408 SF

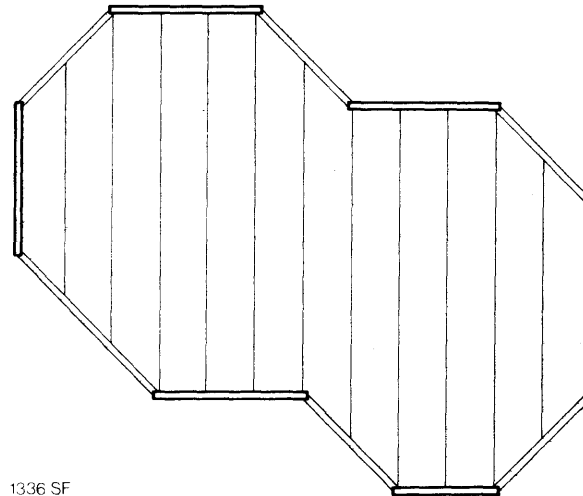

1336 SF

832 / 1376 SF

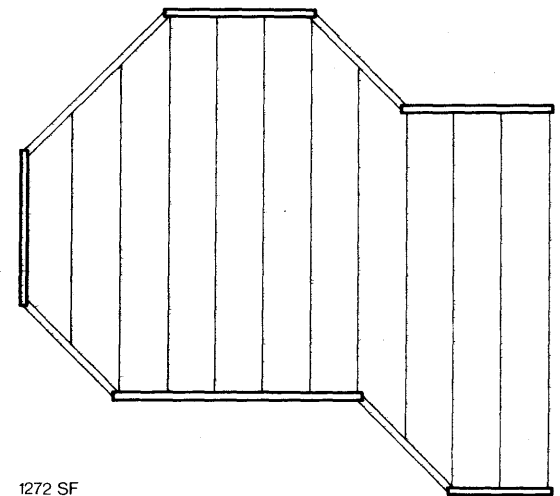

1272 SF

704 / 1400 SF

The structural system consists of concrete load-bearing wall panels and reinforced concrete beams which support precast, prestressed, hollow core floor planks. The beams, when placed at the diagonal between the ends of the bearing walls, stabilize the structure against lateral load in low and midrise buildings. Core structure braces the surrounding structure in highrise buildings.

The precast, reinforced concrete bearing walls are 8", 10" and 12" thick depending on the height of the structure. The walls are designed in four lengths: 8'-0, 12'-0, 16'-0 and 20'-0. Two inch diameter, vertical, post-tensioning sleeves are cast within the wall. The sleeves begin 2'-0 in from the end of the wall and are at intervals of 4'-0. The wall panels may be post-tensioned every one, two or three floors from the foundation up to form a practically monolithic wall diaphragm over the total number of stories. The wall panels must be supported by each other continuously over the full height of the building. But, panels can cantilever 4'-0 from the one below, provided 4'-0 is no more than one-fourth of the total length of the cantilevering wall.

Precast, reinforced concrete beams are 8" thick and 18" deep. The beams are divided into two sets: diagonal span and perpendicular span. Diagonal beams span between ends of bearing walls at a 45° angle, over lengths of 5'-8, 11'-4 and 17'-0. Diagonal beams require pointed ends to allow two beams to bear on the end of one wall. The second set of beams span at a 90° or 180°

angle between ends of bearing walls, over lengths of 8'-0, 12'-0 and 16'-0. Welding plates connected to the reinforcing are cast into the ends of the beams, and exposed plates are cast into the face of the beam seats. Thus, beams are welded to wall panels to secure them.

The floor planks can be any common hollow core, precast or extruded, prestressed floor planks available. Depending on the span and/or live load, the planks are 8", 10" or 12" thick. The planks are available in a variety of widths depending on the production design. The width of the plank provides the module for the structural system, resulting in dimensioning of the lengths of bearing walls and the diagonal lengths of beams. The planks can be cut to length and at any angle up to 45°. Planks are from 12'-0 to 40'-0 long at 4'-0 intervals. They are used in five shapes derived from various combinations of square and diagonal ends. The planks can cantilever to 5'-0 on their own, but assisted by reinforcing strands in the topping the cantilever can be increased to 8'-0 for a 32'-0 span. The longitudinal edges of the planks are chamfered so that adjacent planks form a groove, which is grouted to form a shear key between the individual planks. The hollow core planks, grouted shear key, and a 1" to 2" topping provide a level, homogeneous floor structure. Openings can be cut in extruded planks by sawing rectangular openings or by core drilling round openings. Openings cannot be located so as to interrupt an interior web and cut the reinforcing strand.

STRUCTURAL SYSTEM

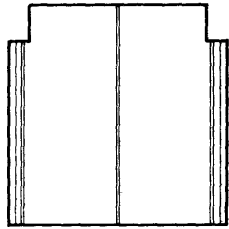

BW 8'-0

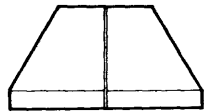

RW 8'-0



B 5'-8



B 8'-0

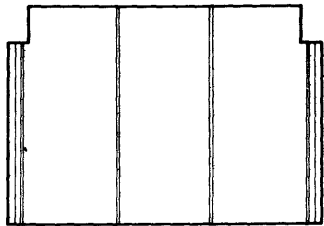

BW 12'-0

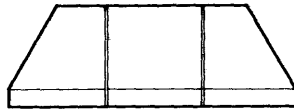

RW 12'-0



B 11'-4



B 12'-0

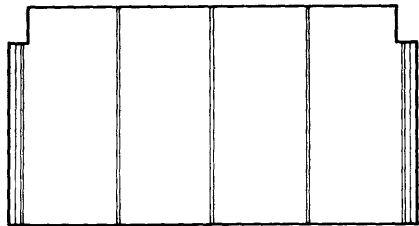

BW 16'-0



RW 16'-0

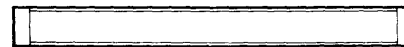

B 17'-0

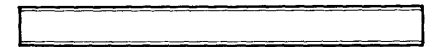

B 16'-0

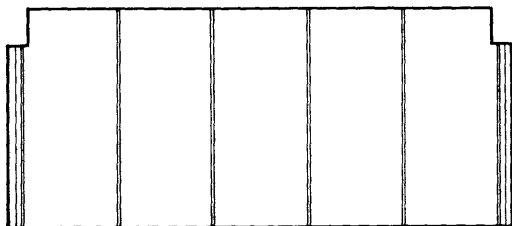

BW 20'-0

BEARING WALLS

ROOFTOP WALLS

BEAMS

STRUCTURAL COMPONENTS

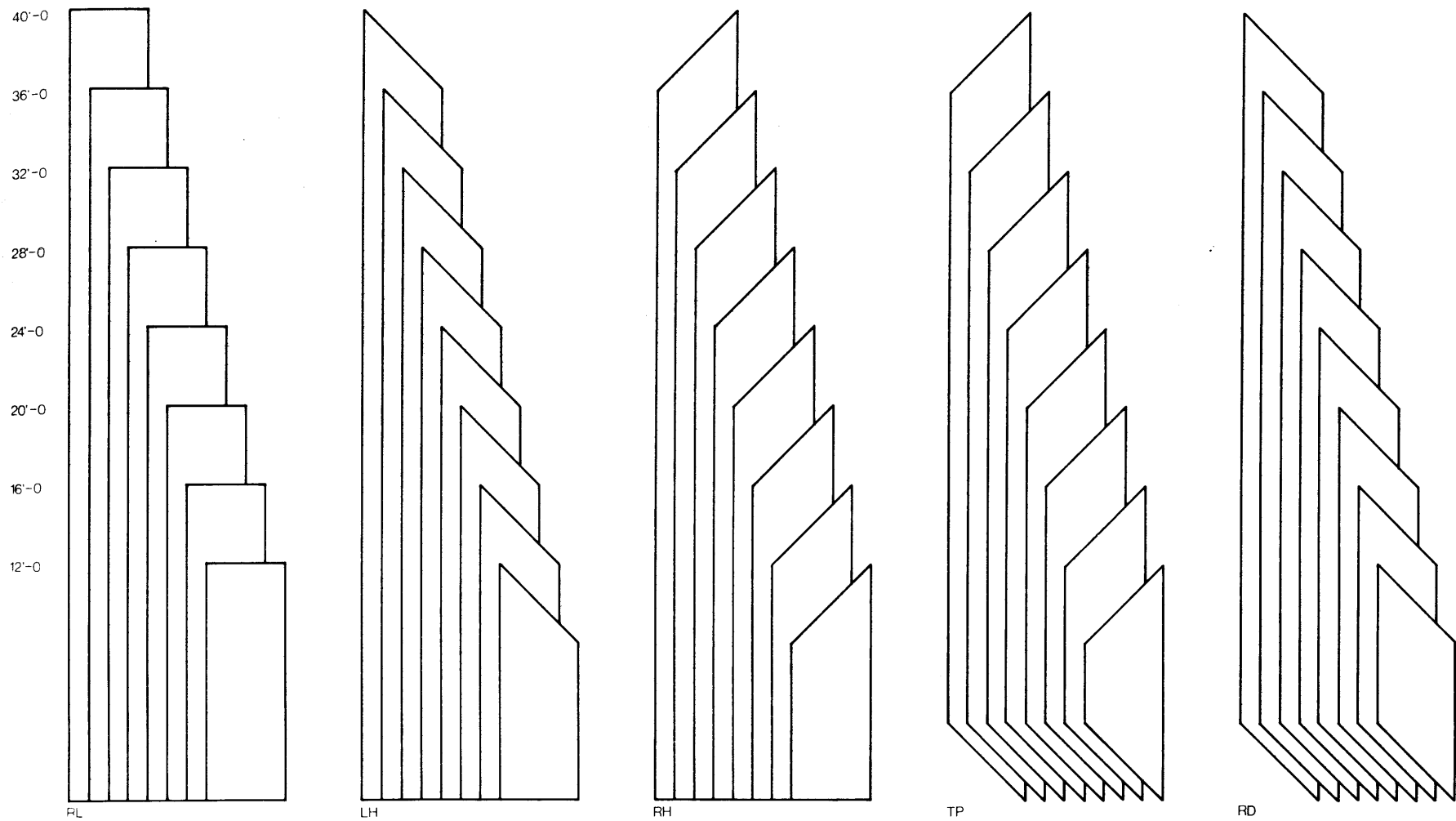

PRECAST PLANKS

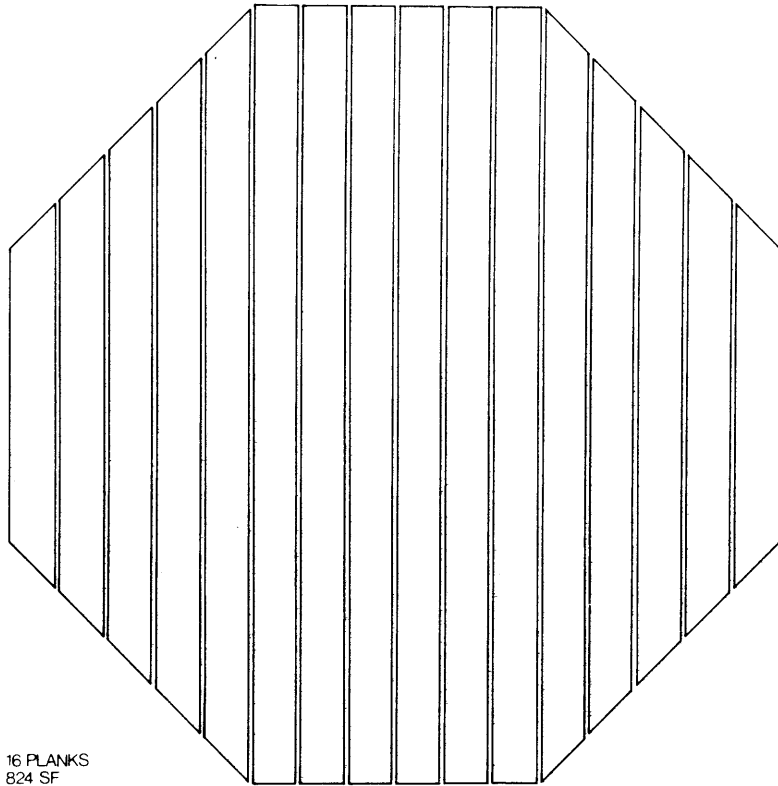

16 PLANKS
824 SF

32'-0

MAXIMUM SPAN 32'-0
 MAXIMUM CANTILEVER 4'-0
 DEAD LOAD, PLF 120
 SECONDARY WIDTHS 1'-4

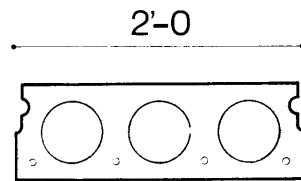

2'-0

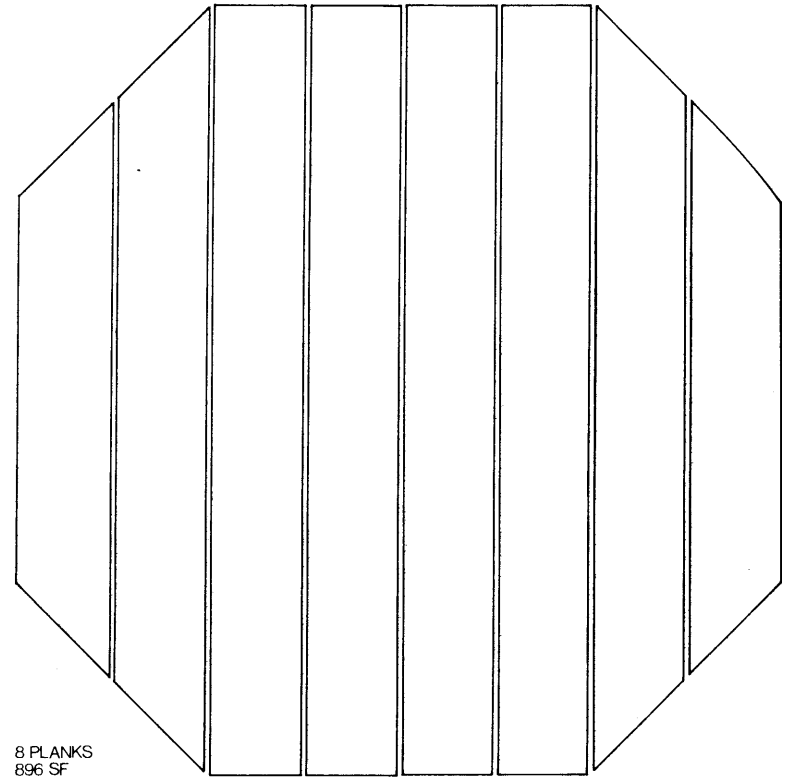

8 PLANKS
896 SF

32'-0

MAXIMUM SPAN 36'-0
 MAXIMUM CANTILEVER 5'-0
 DEAD LOAD, PLF 188
 SECONDARY WIDTHS 8'-0

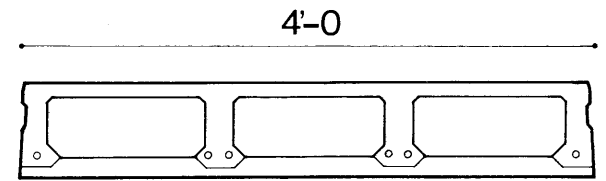

4'-0

STANDARD PRECAST PLANKS

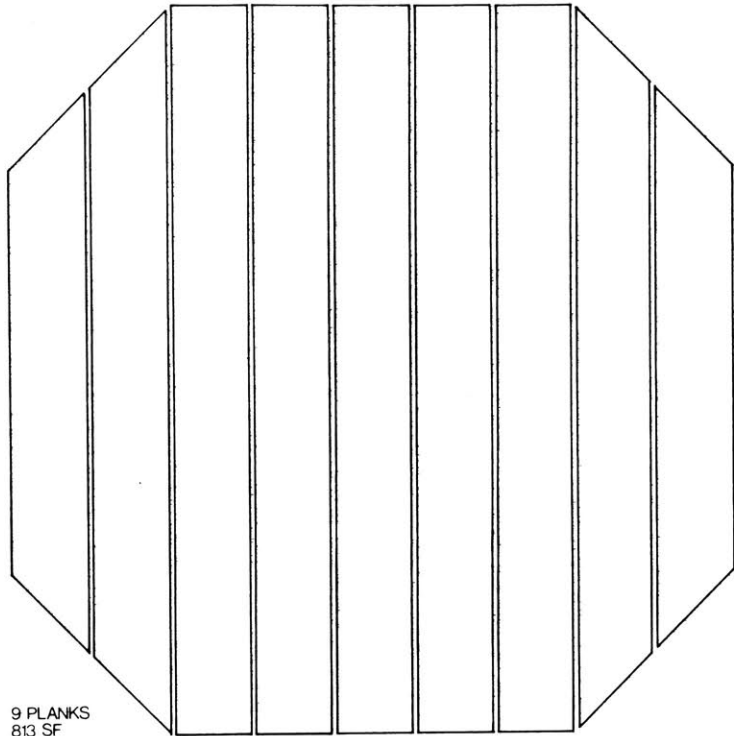

9 PLANKS
813 SF

30'-0/9 M

MAXIMUM SPAN	34-0
MAXIMUM CANTILEVER	4-0
DEAD LOAD, PLF	322
SECONDARY WIDTHS	1-8

3'-4/1M

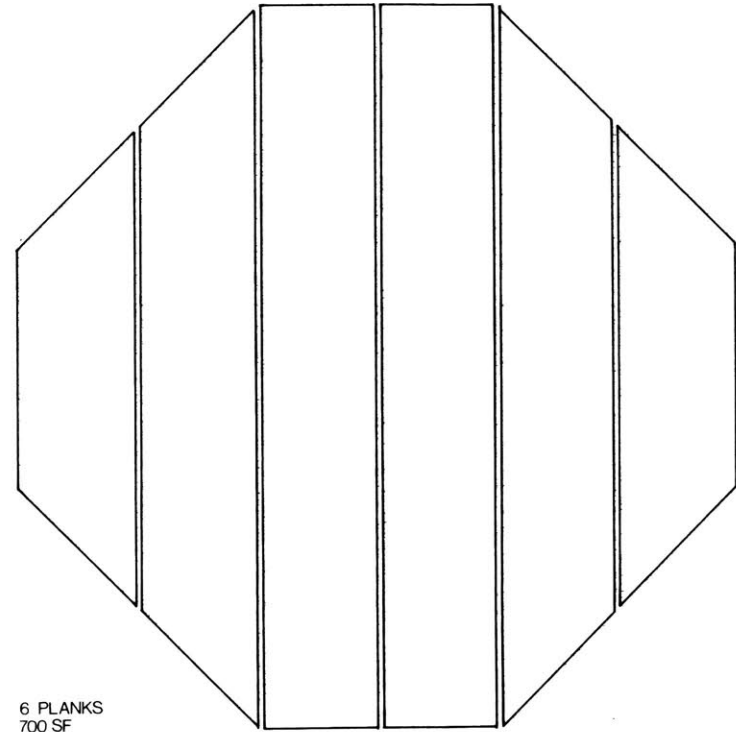
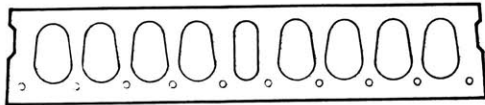

6 PLANKS
700 SF

30'-0/9 M

MAXIMUM SPAN	34-0
MAXIMUM CANTILEVER	4-0
DEAD LOAD, PLF	483
SECONDARY WIDTHS	2-6

5'-0/15M

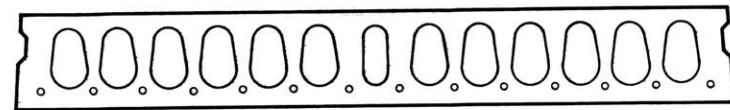

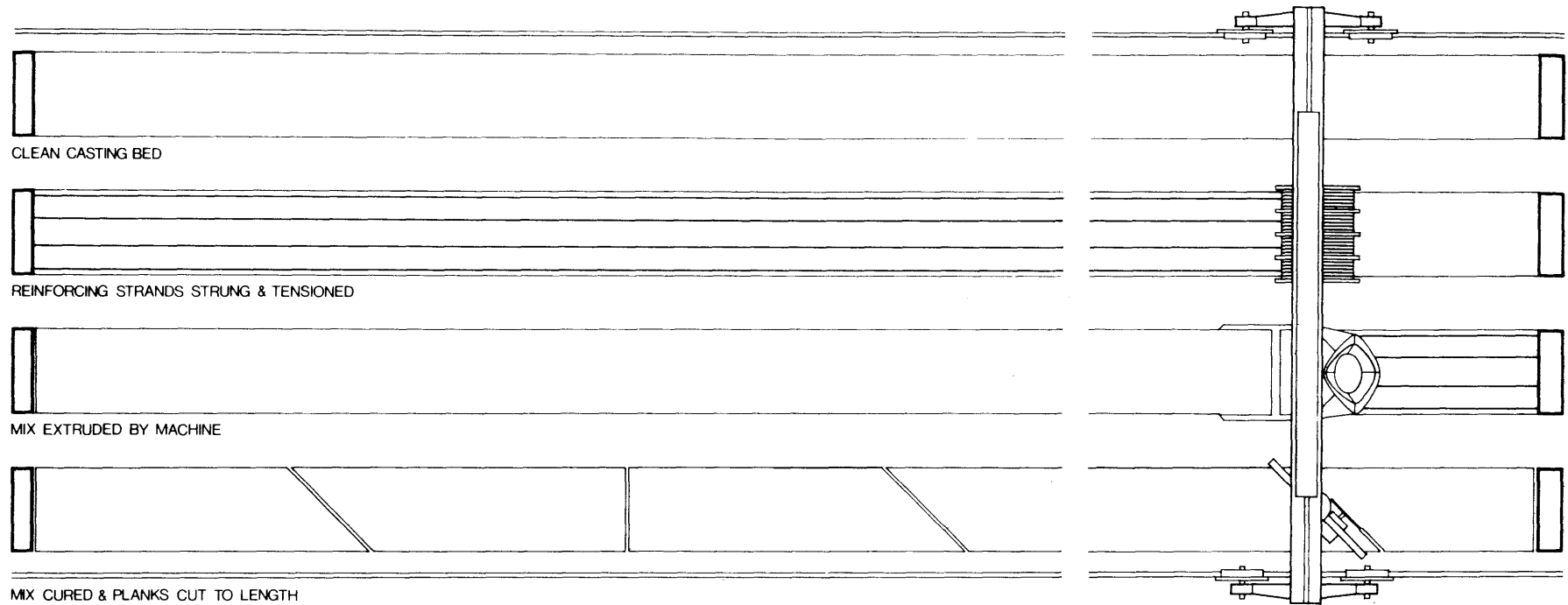

Bearing walls may be either cast in vertical battery molds or horizontal bed molds. Both of these molds are made of steel which gives stability, reuseability, cleanability and ability to be vibrated. Although battery molds can be used, bed molds are less expensive for lower productions. Bed molds are desirable if only one side of the wall requires a particular finish. It is also easier to place reinforcing steel and to pour mix in bed molds.

Beams are cast with the depth of the beam vertical to allow prestressing and to facilitate loading from the steel mold. Beam molds can be blocked to cast a beam which

is shorter or has a different end condition. The hollow core floor planks are machine-extruded on long casting beds. Reinforcing strands are stretched along the full 600', and the machine forms, pours and screeds the concrete while moving along the bed. There are usually at least four beds in operation to allow fabrication while previous pours are curing. Planks are sawn to length after the concrete has set adequately to hold the reinforcing bars. Planks may be cut at any angle between 90° and 135° to the edge, and may be specified with a rough top surface to ease bonding with the topping.

COMPONENT PRODUCTION

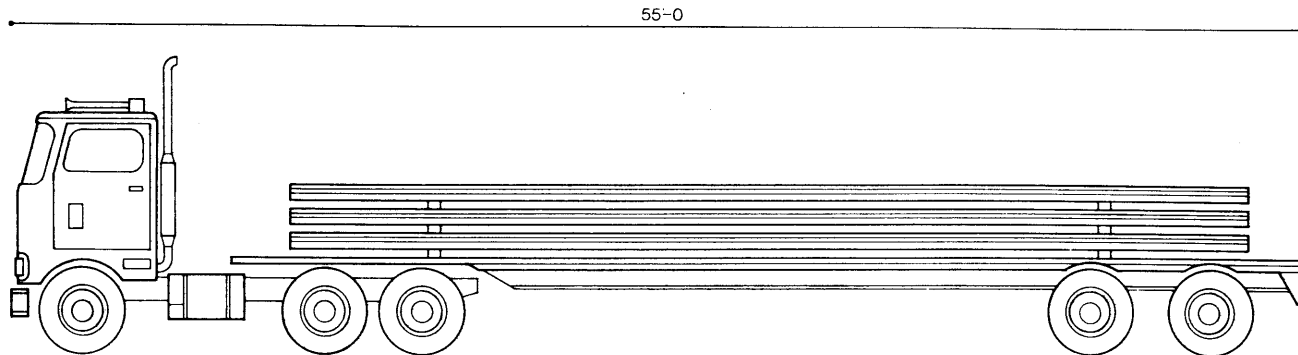

40'-0 PLANKS

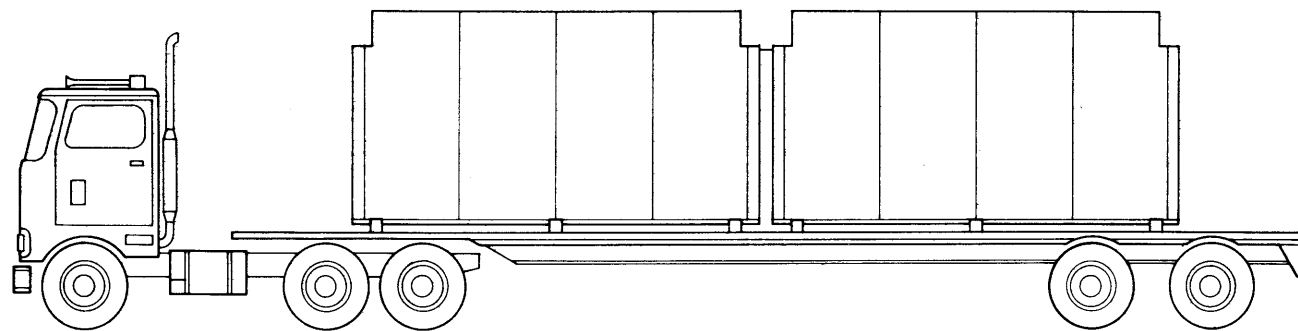
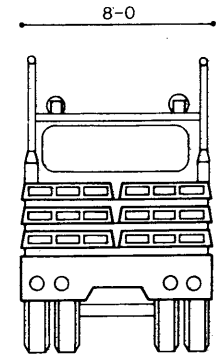

16'-0/9'-0 BEARING WALLS

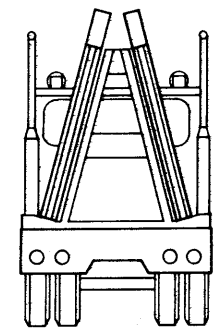

Transportation of the structural components is usually by truck over public roadways. The size and weight limitations of a load are set by individual state laws. The maximum load size without a permit is a width of 8'-0, a length of 60'-0, a height of 13'-6 from the road bed and a weight of 36.5 tons.

The size, weight and shape of all structural components in this system allow them to be transported without a special road permit. The largest, heaviest component is the 20'-0 reinforced bearing wall. A trailer of 4'-0 plus the 9'-0 height of the bearing wall is 13'-0, 6" less than the

maximum allowable height. One truck may carry up to eight short bearing walls in one load. The weight of the thickest 20'-0 bearing wall is 12 tons plus the weight of the truck and trailer is a total of 24.5 tons, 12 tons less than the maximum. The width of two cored planks loaded side by side is 8'-0 which is the maximum allowable width. With the length of the longest being 40'-0, the total length of truck cab and load is 55'-0, 5'-0 less than the 60'-0 maximum allowable length.

The ability to transport components without a special permit allows economy in transportation and flexibility of delivery.

COMPONENT TRANSPORTATION

Erection of this concrete bearing wall system consists of a simple repetitive procedure. Footings and foundation walls are cast in place. Post-tensioning rods are connected by a coupler to an anchor which is cast in the foundation. A wall panel is lowered into position while the post-tensioning rods are threaded into sleeves. Once the wall is in place and temporarily braced and leveled, the beams are lowered into position, leveled and welded. The floor planks are lowered into position next. The centers of the planks are jacked up to achieve similar cambers. Couplers are installed between plank ends. The ends of the planks and the gap at the top of the bearing between the planks can be grouted. Planks and shear keys are grouted and the next bearing wall is lowered over the post-tensioning rods of the floor below. The rods are pulled with a hydraulic jack to a uniform tension and are cinched with a threaded lock nut. The procedure is repeated for succeeding floors. Interior finishes are applied to structurally secure floors.

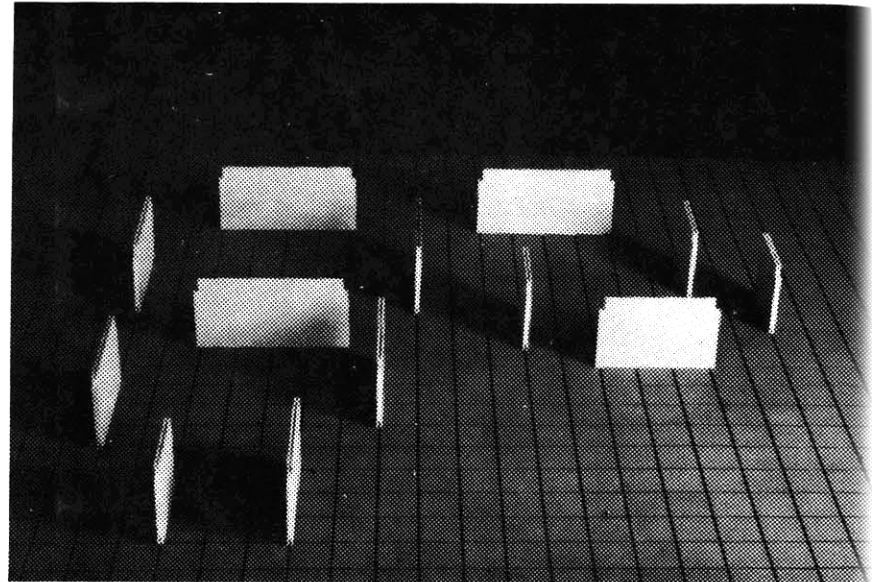

1

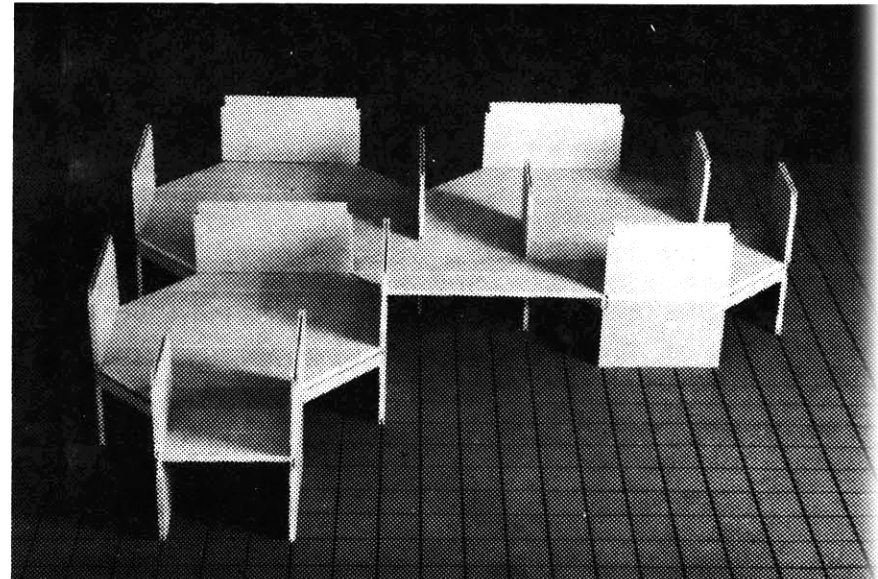

4

COMPONENT ERECTION

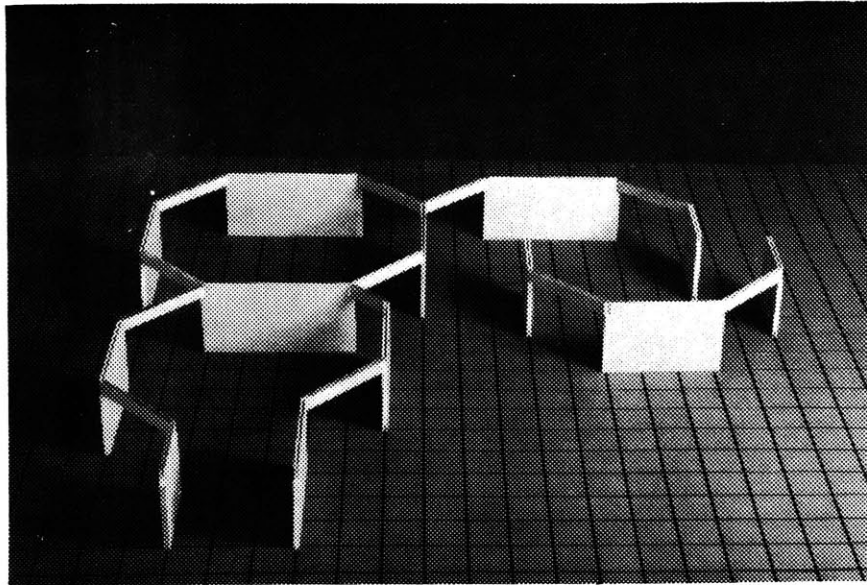

2

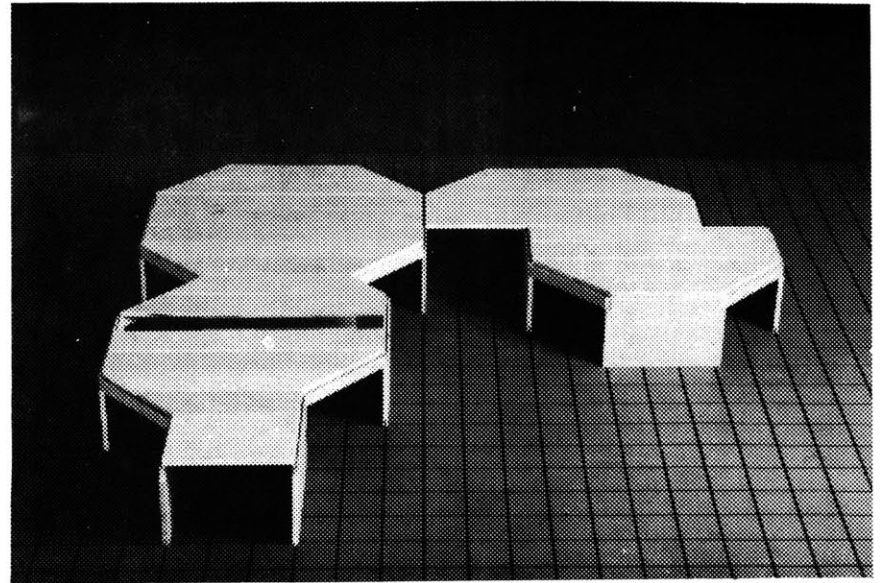

3



5

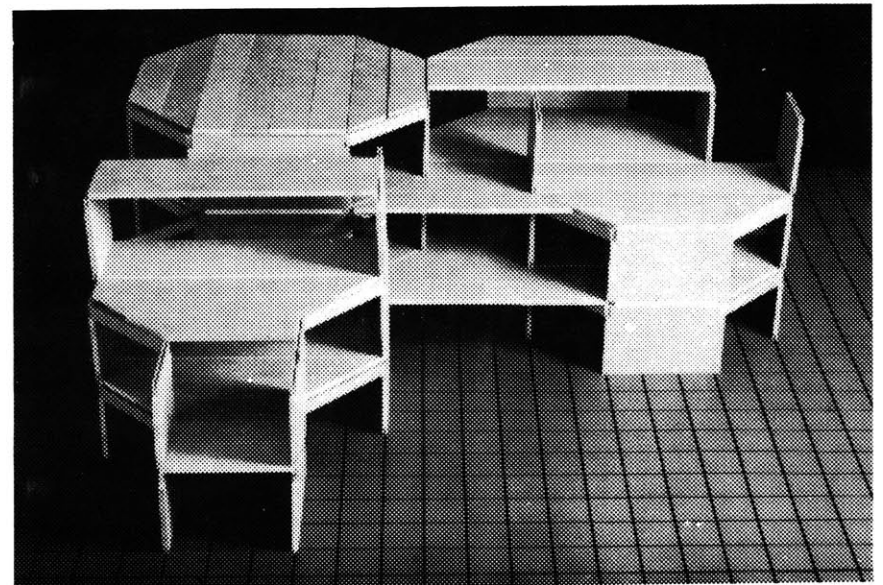

6

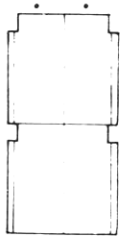

B8

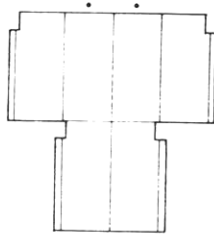
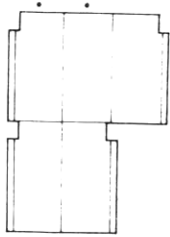

B12

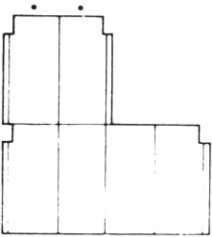
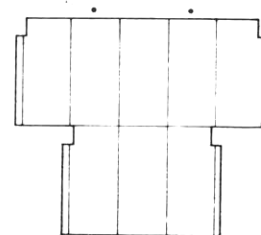
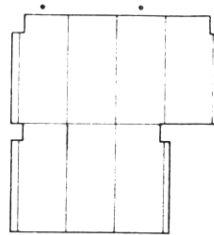
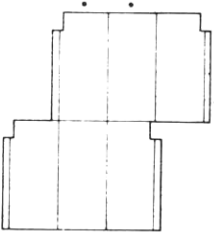
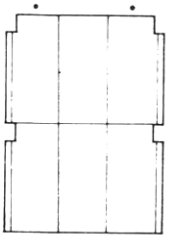

B16

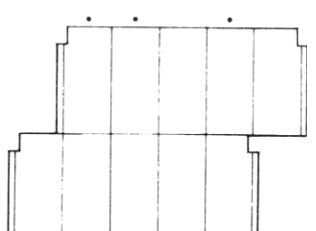
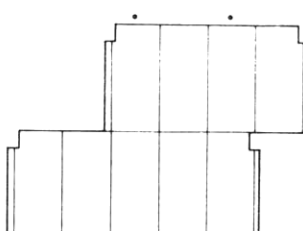
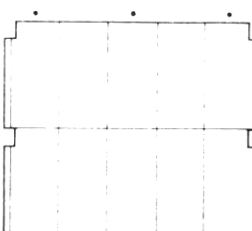
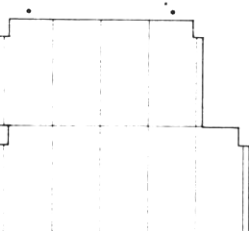
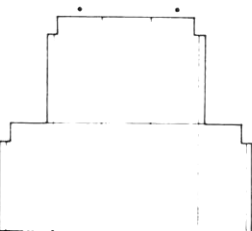
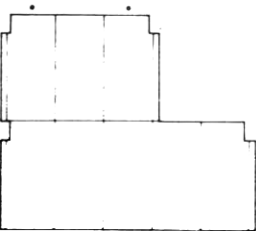
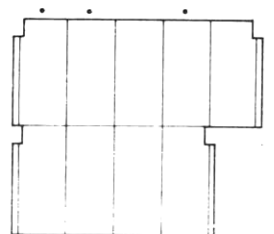
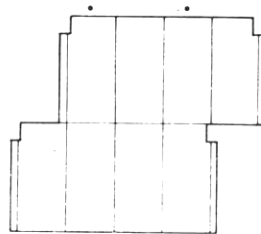
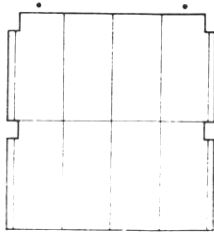
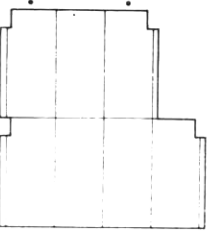
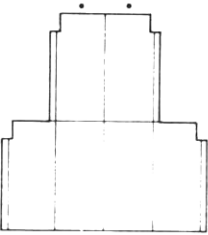

E29

BEARING WALL STACKING

POST-TENSIONING ROD LOCATION •

POST-TENSIONING DIAGRAM

U

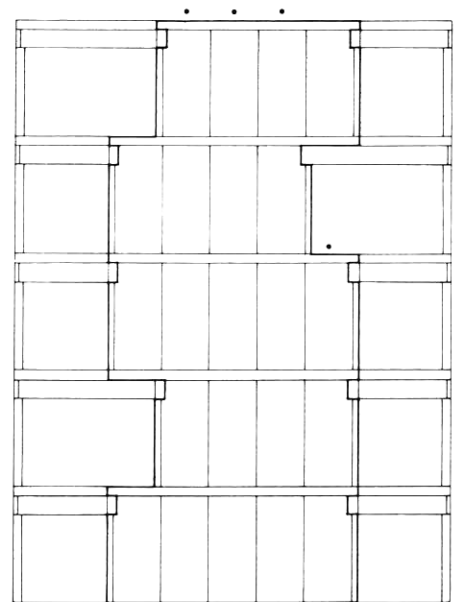
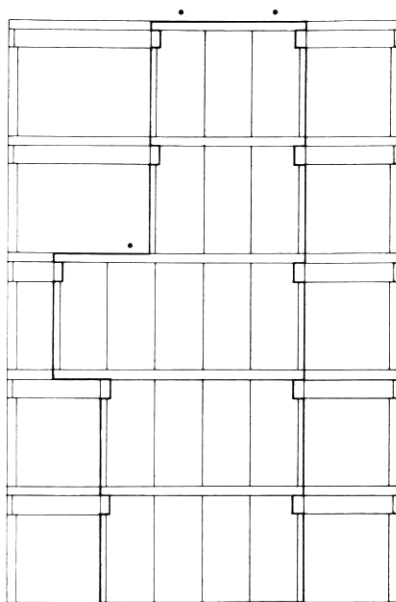
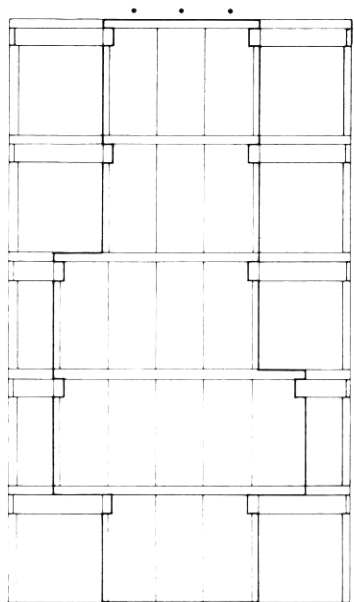
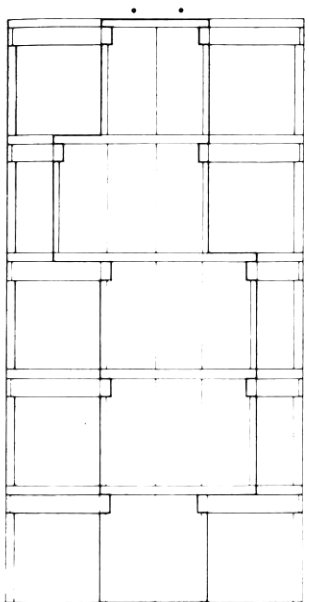
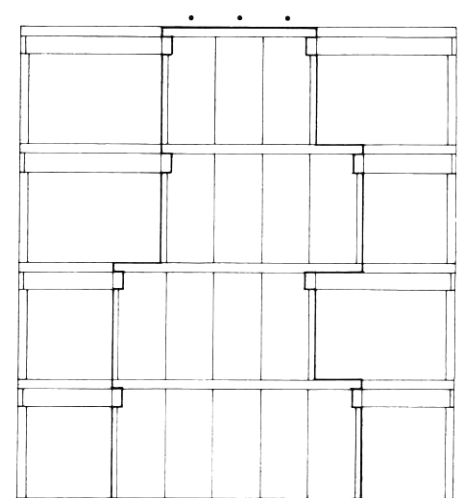
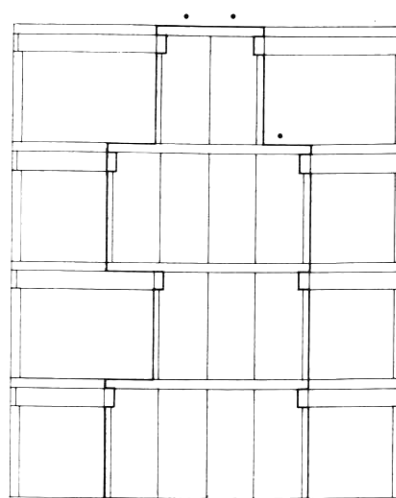
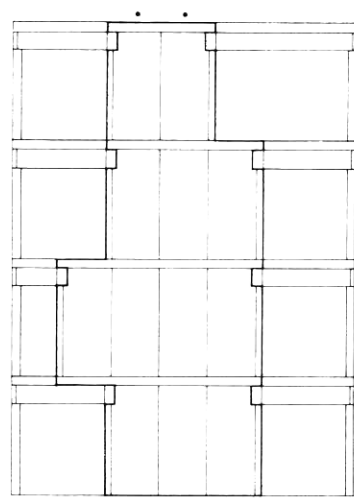
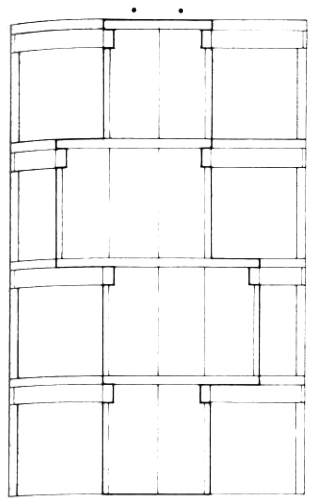

B2
B12
BEARING WALL ELEVATION

B16

B20

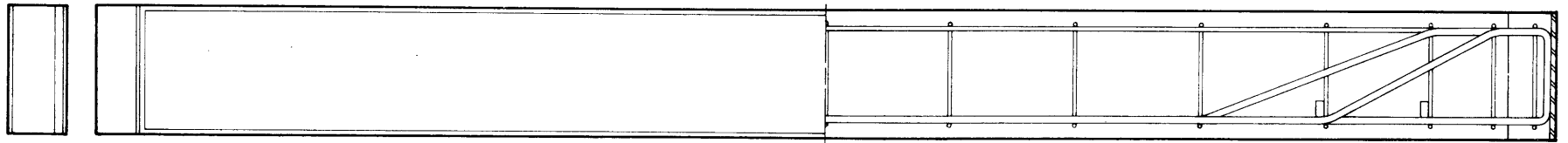

17'-0 DIAGONAL BEAM

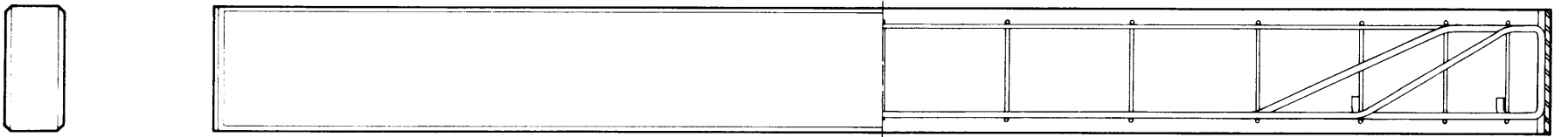
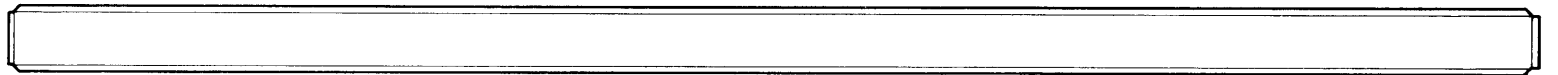

16'-0 PERPENDICULAR BEAM

REINFORCING

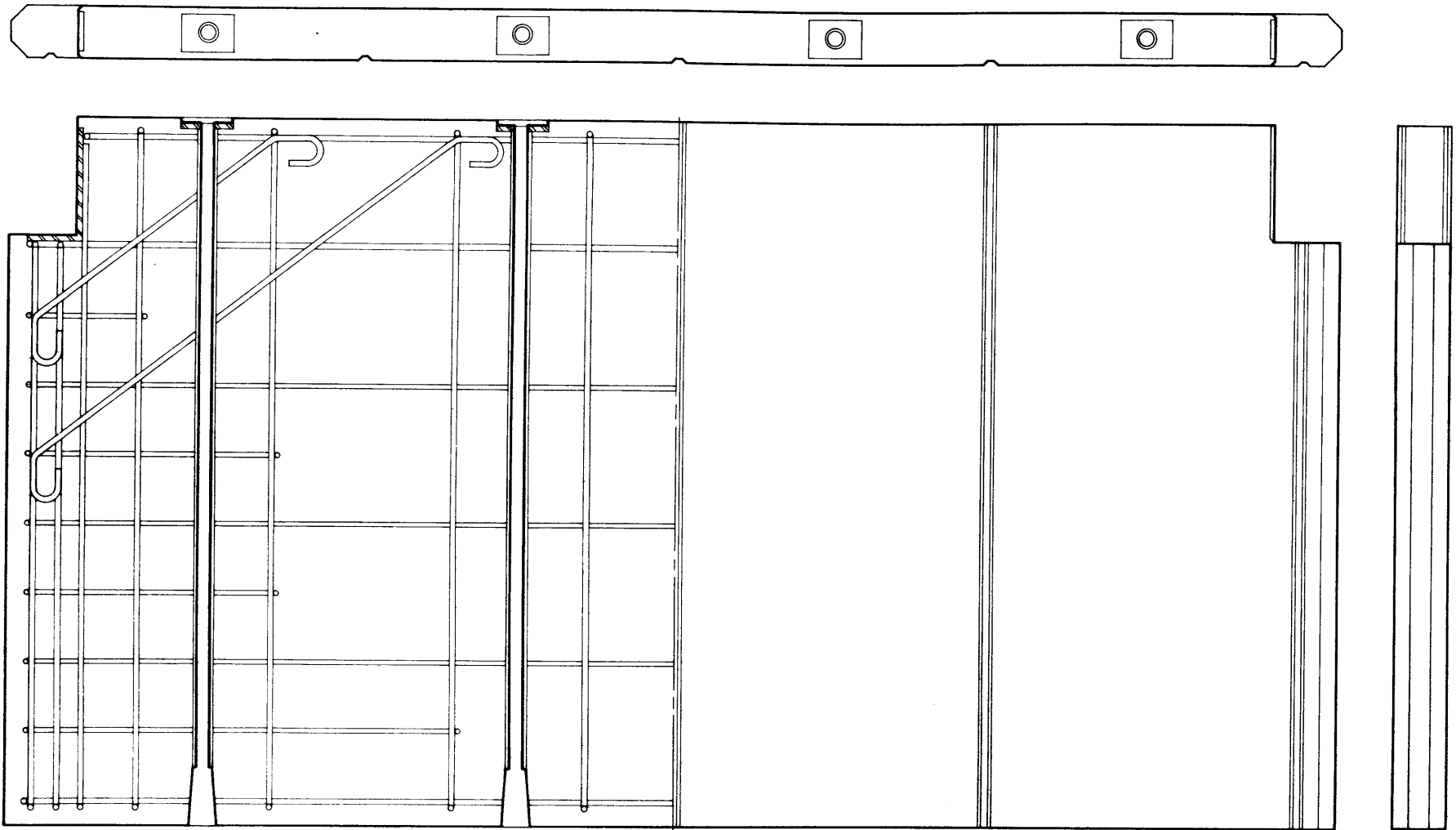

16'-0 BEARING WALL

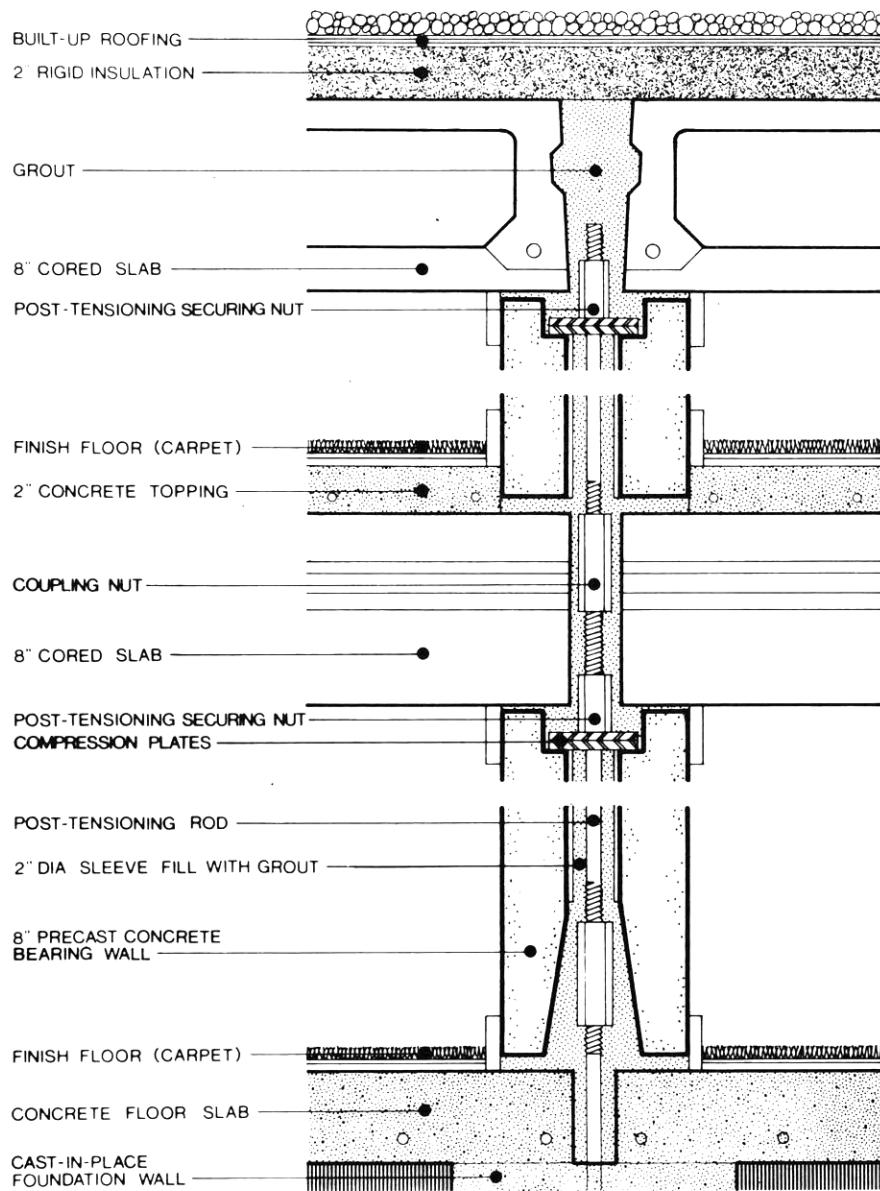

SECTION AT INTERIOR BEARING WALL

CONSTRUCTION DETAILS

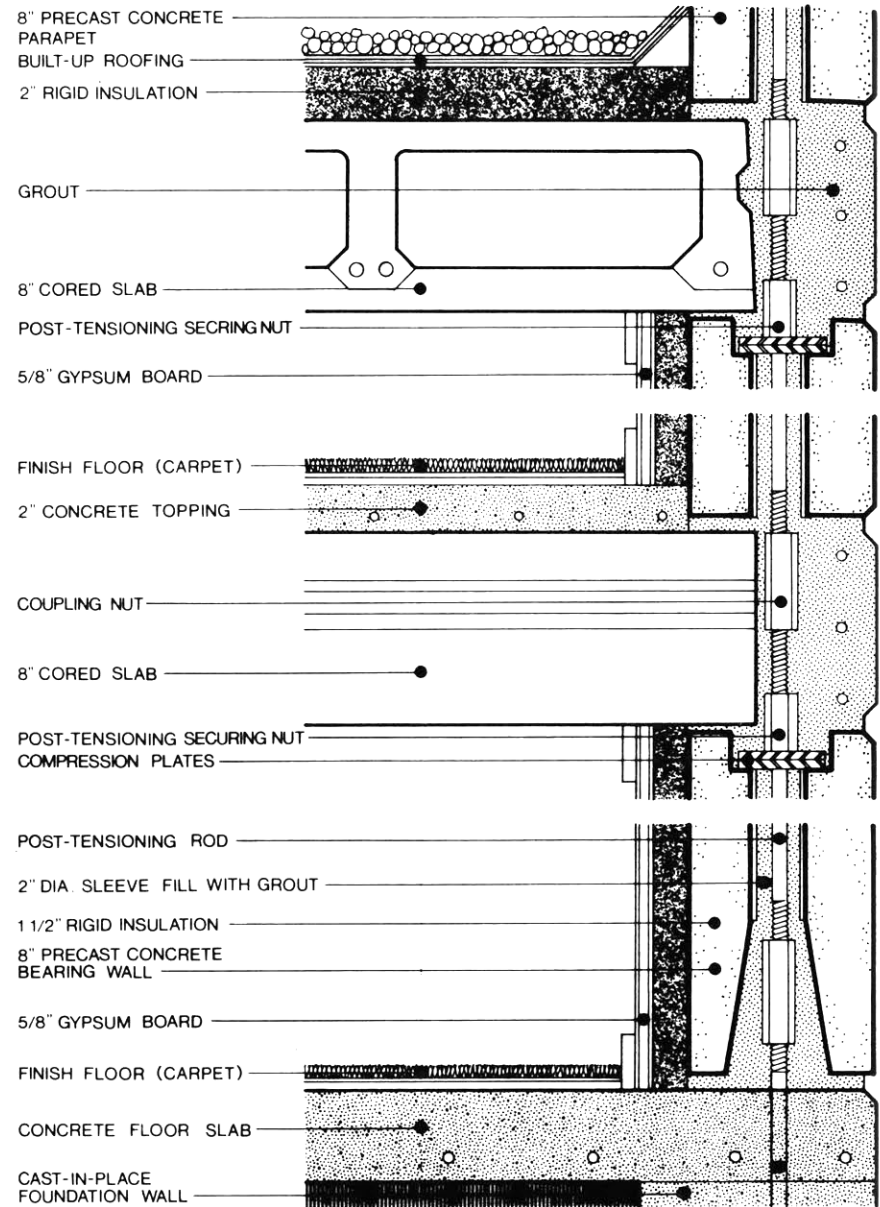

SECTION AT EXTERIOR BEARING WALL

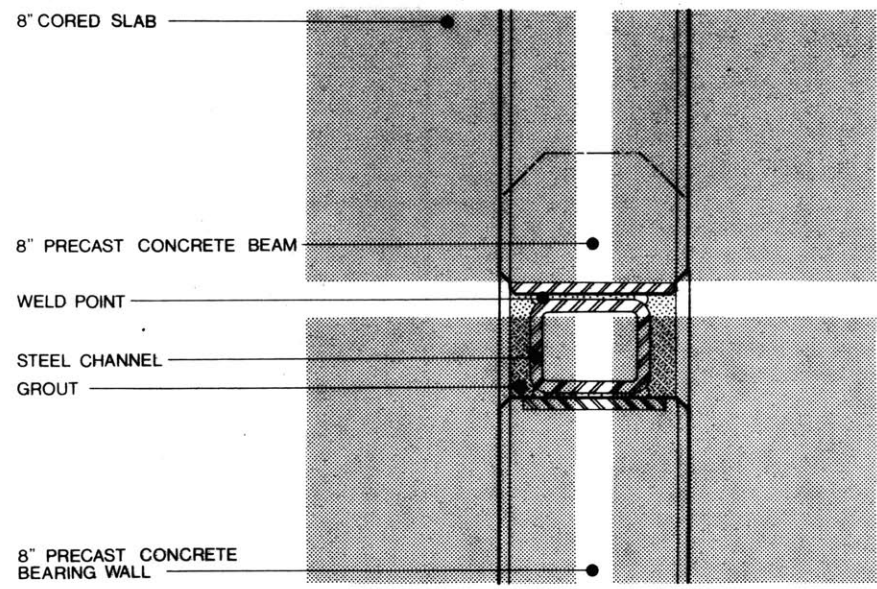
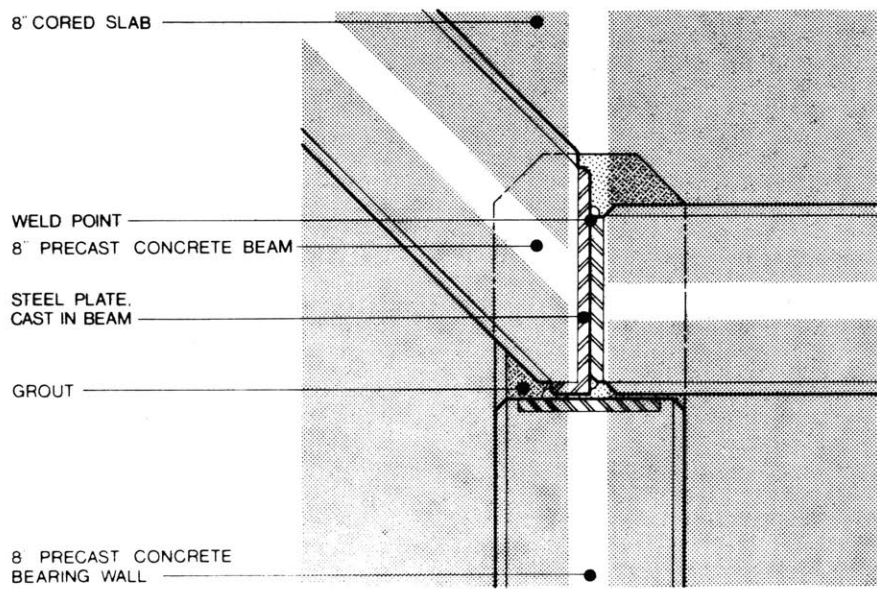
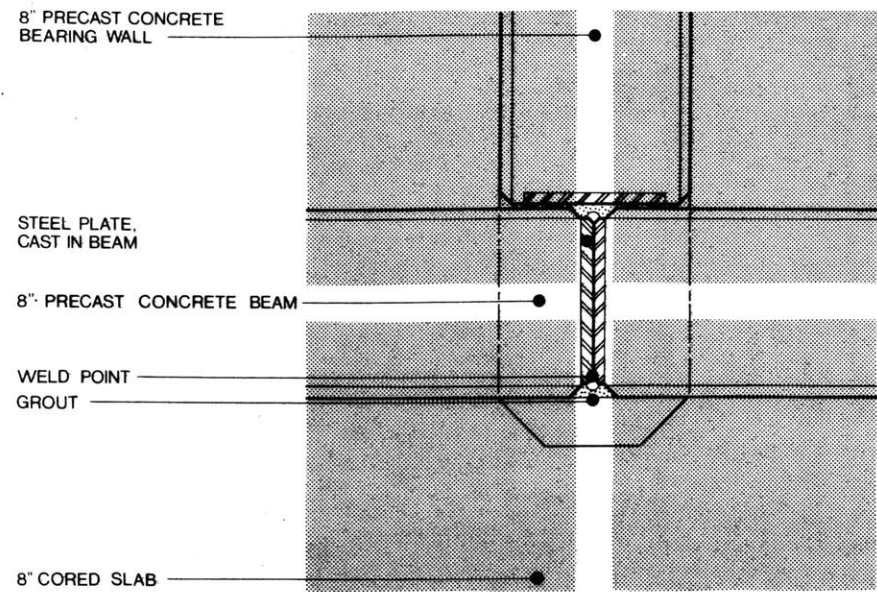
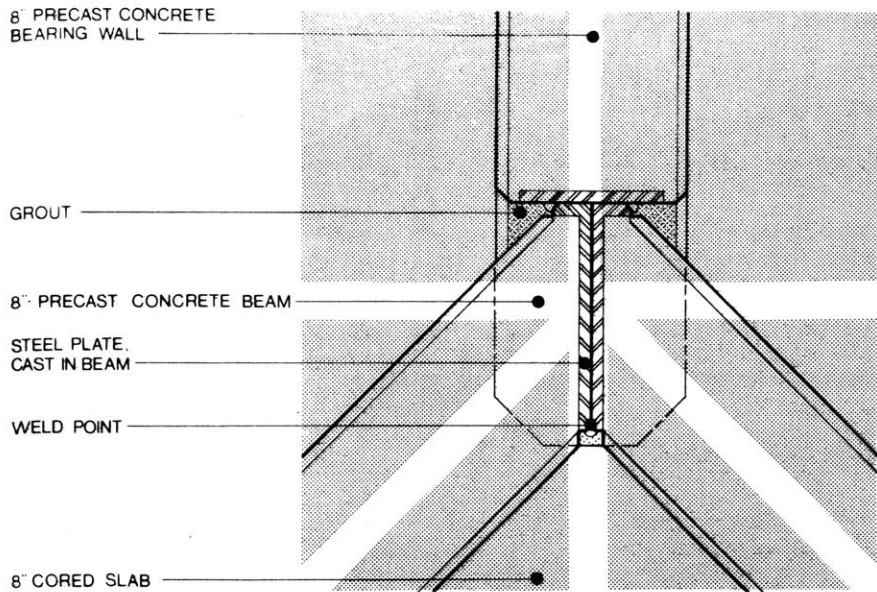

BEAM & BEARING WALL SEAT OPTIONS

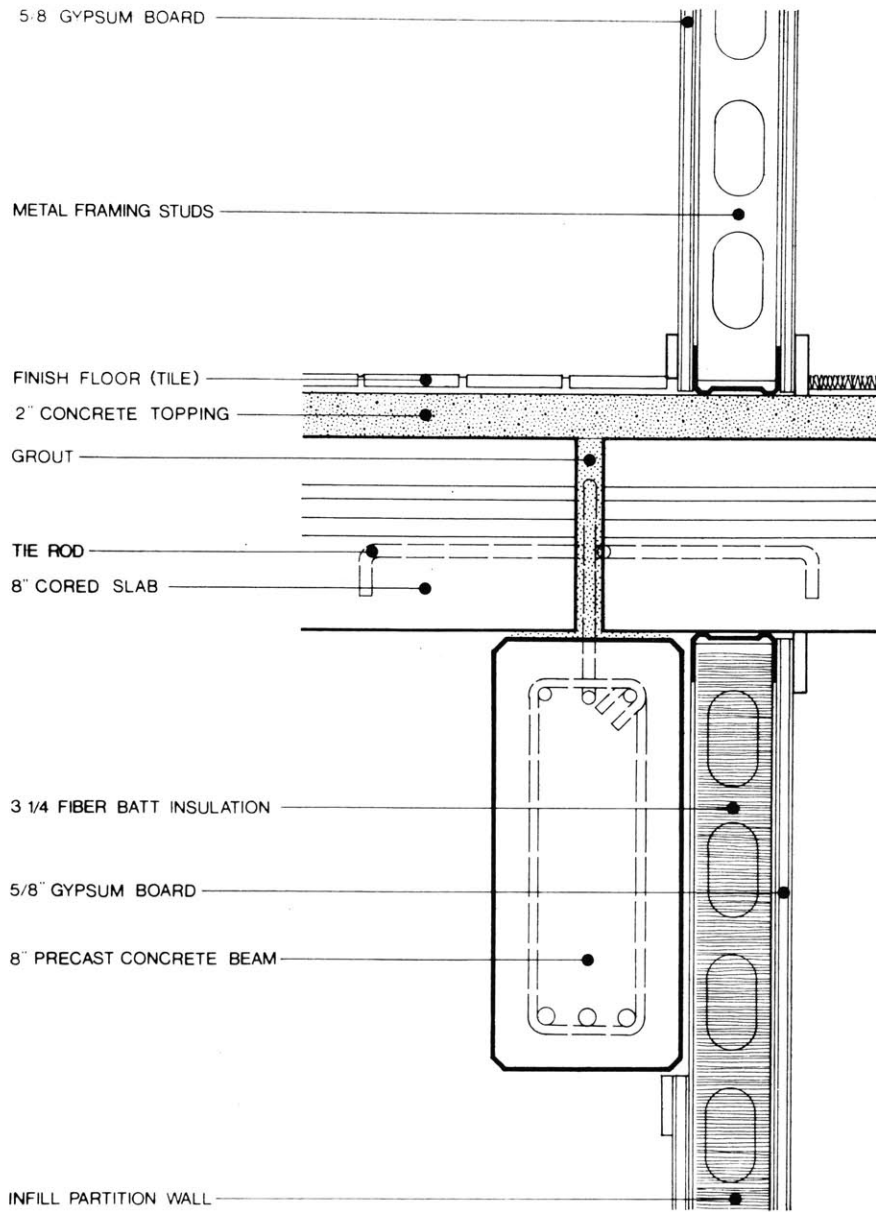

INTERIOR BEAM & PARTITION WALL

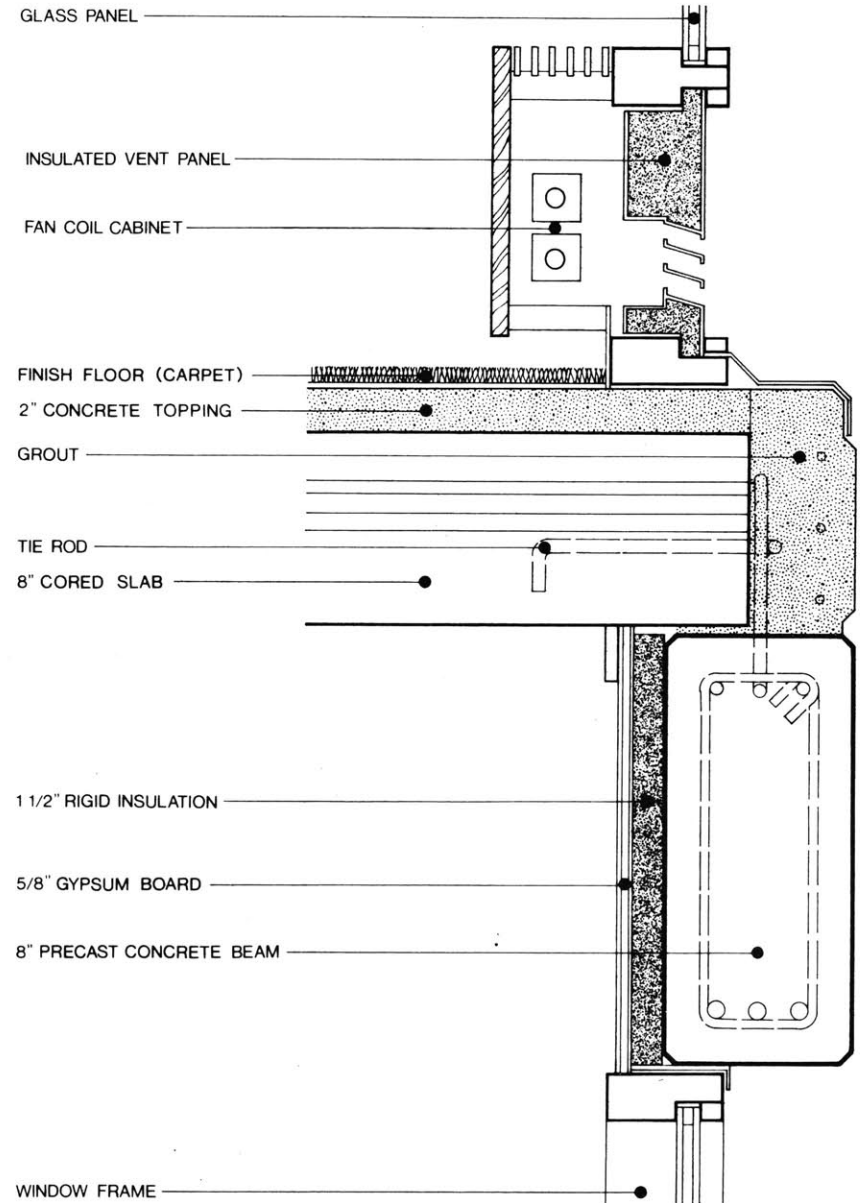

EXTERIOR BEAM & INFILL PANEL

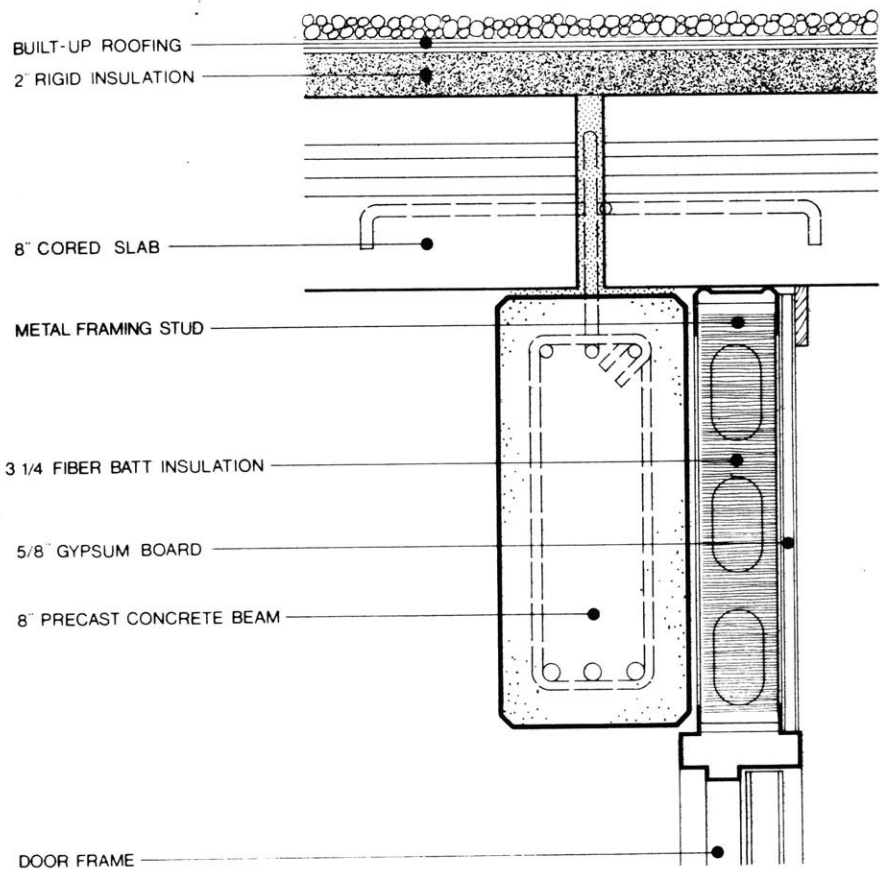

INTERIOR BEAM AT ROOF

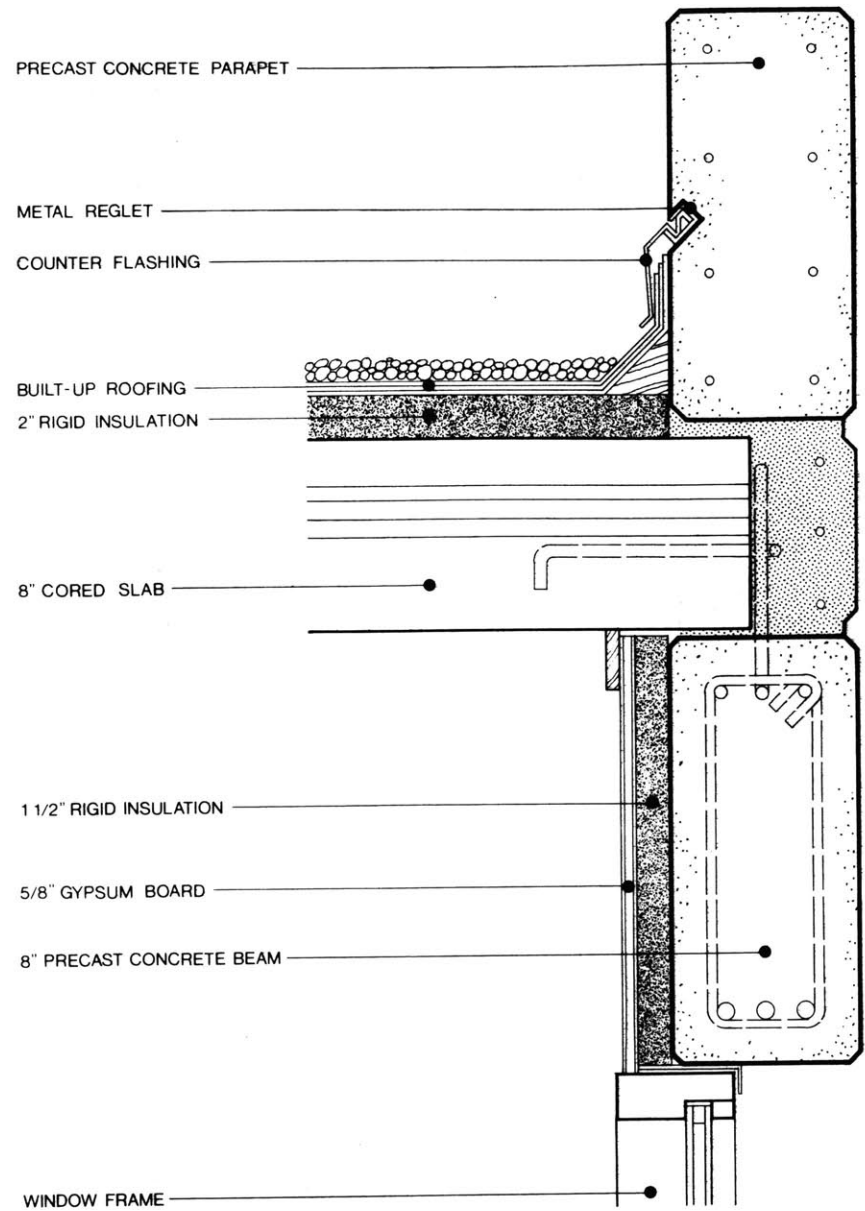

EXTERIOR BEAM AT PARAPIT

1'-1.5"

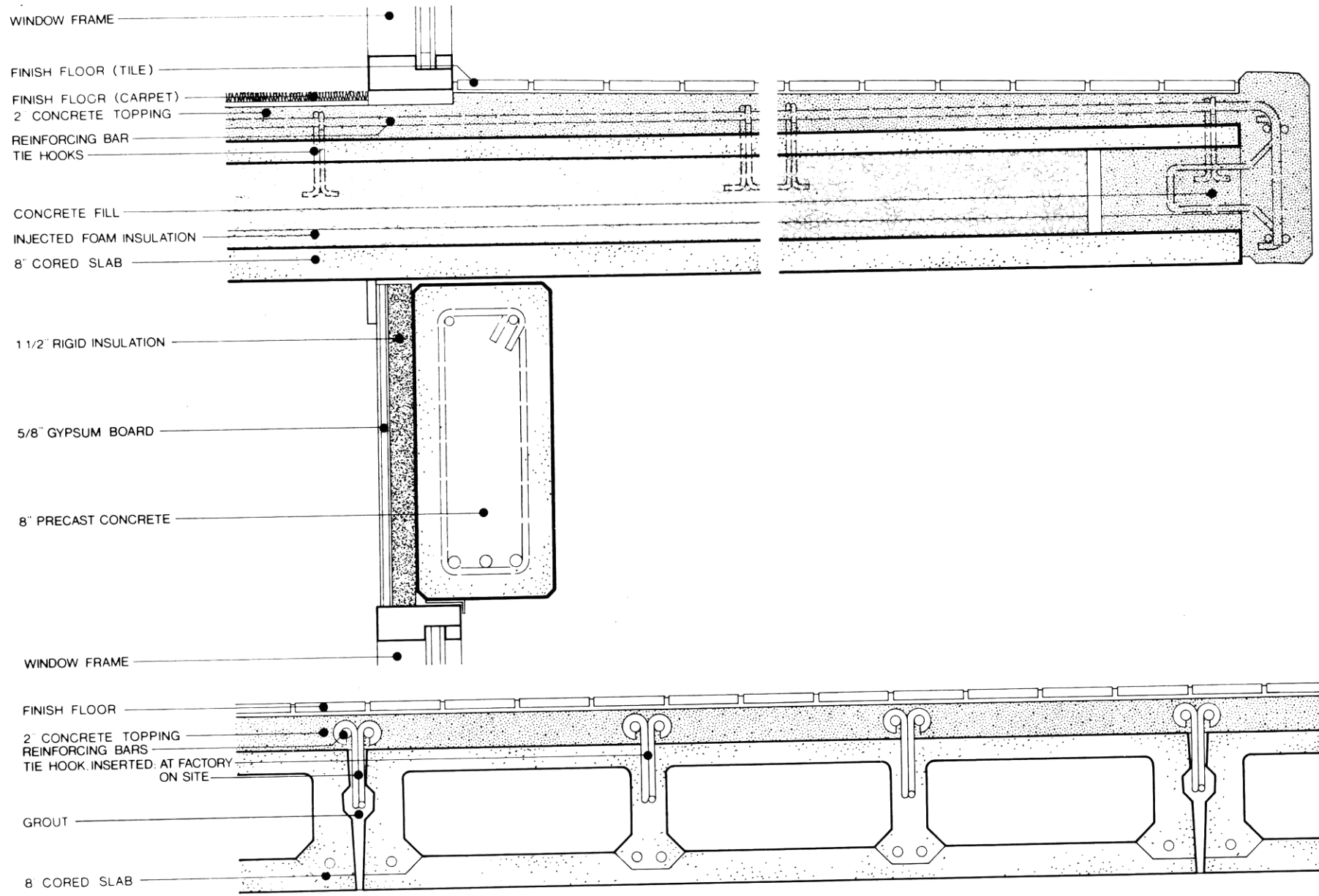

CANTILEVER AT EXTERIOR BEAM

1'-1.5"

CORES: Core components are similar to those of any mid or highrise building. The cores are of two types relating to the two basic structural situations. The first is ordered on the 4'-0 module and the second on the diagonal 5'-8 module.

BATHROOMS: Typical rectilinear bathrooms do not apply themselves well to the interior planning of these units. The bathroom examples shown are derived from two basic prototypes. They both have a 135° angle allowing them to fit within the unit at its perimeter.

OPENINGS: Window frames are metal allowing a wide range of infill panel possibilities. There are five modular widths and seven options for horizontal mullion location. The widths may be combined to fill all possible openings. Because of the possibility of close opening proximity and the variability of opening orientation, brise-soleil fins may be applied to direct views and control sun exposure.

INTERIOR PARTITIONS: Since the bearing wall, beam and plank system is structurally self-sufficient, the remaining interior walls and partitions can take a variety of forms. Metal-gypsum board stud-wall partitions are suggested because of their ease of assembly, stability, adaptability and ease of connection to concrete floors, walls and ceilings.

HEATING: A number of unit heating systems may be applied to this design. These consist of closet HVAC systems, window fan coil units, convection baseboard units or

electric baseboard units. Convection baseboard and fan coil units depend on hot and/or cold water distribution to the perimeter of the units. This may require a shaft at the front of the units leading directly from the mechanical space. Electrical baseboard heating units have low initial cost, but prove to be expensive to operate. It would be advantageous to use individual unit, closet HVAC heating systems. The mechanical space occupies approximately 4sf and is often completely enclosed by partitions. Air would be forced through spaces from diffusers in the mechanical closet or by short duct runs within a false ceiling or within race ways in the cored slabs.

PLUMBING: Hot and cold water and waste pipes are distributed and collected vertically from stacks of paired units. Unit and building plumbing is conventional in design and application. It is entirely feasible to use packaged bathroom-kitchens, but the package units must be lifted to the space before the covering floor structure is in place. It is more realistic to standardize fixture placement and orientation and to use a conventional plumbing wall.

ELECTRICAL: Power is distributed to each unit through electrical conduits within the chase for each stack of apartments. Power wires travel from the stack to each switch and wall plug through conduits laid in the topping. Plugs may be located in interior partitions or flush-mounted in the topping. Telephone wires, television cables and security and smoke alarm systems may also be conveyed in the vertical chase.

SUBSYSTEMS

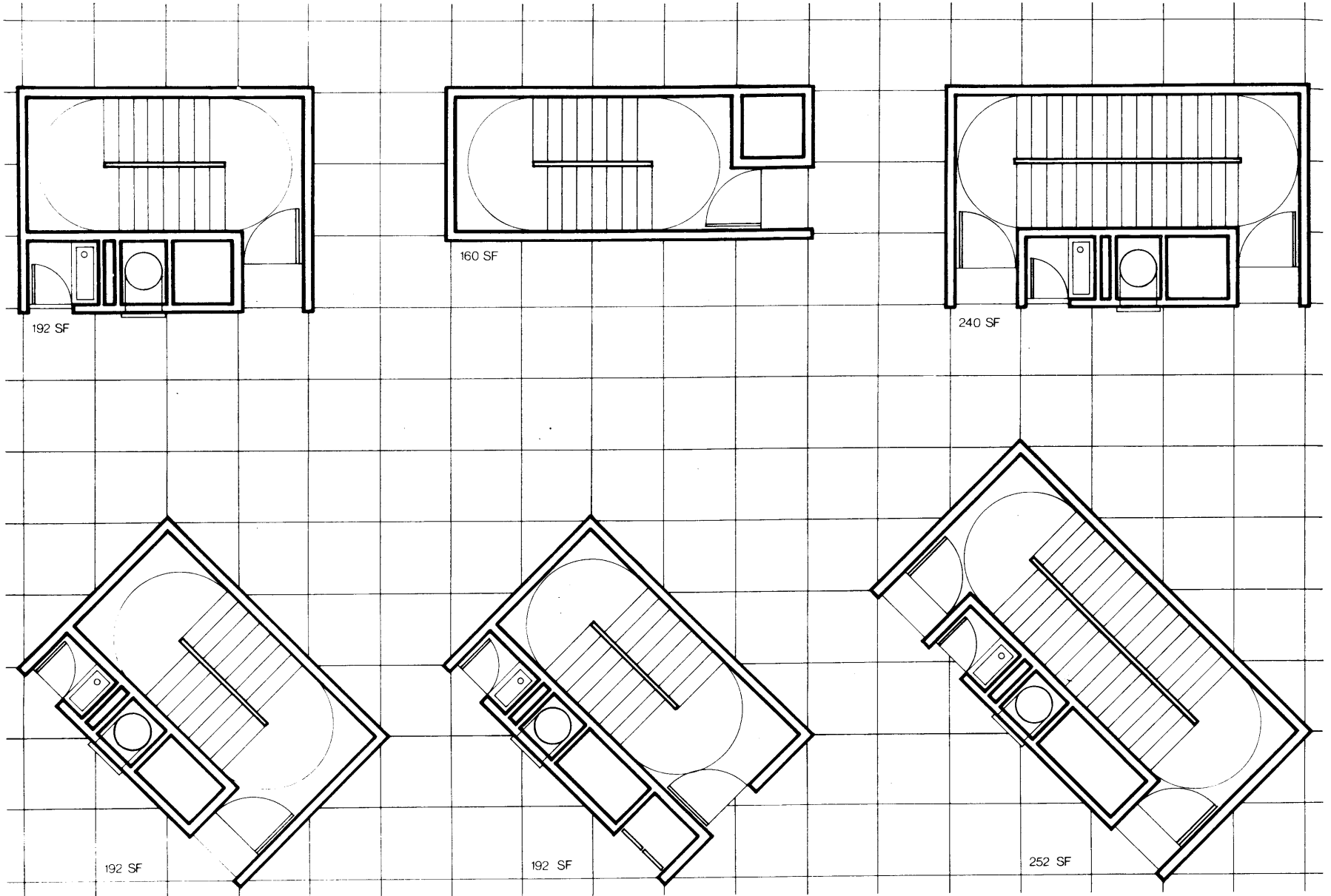

EXIT STAIRS

CORE COMPONENTS

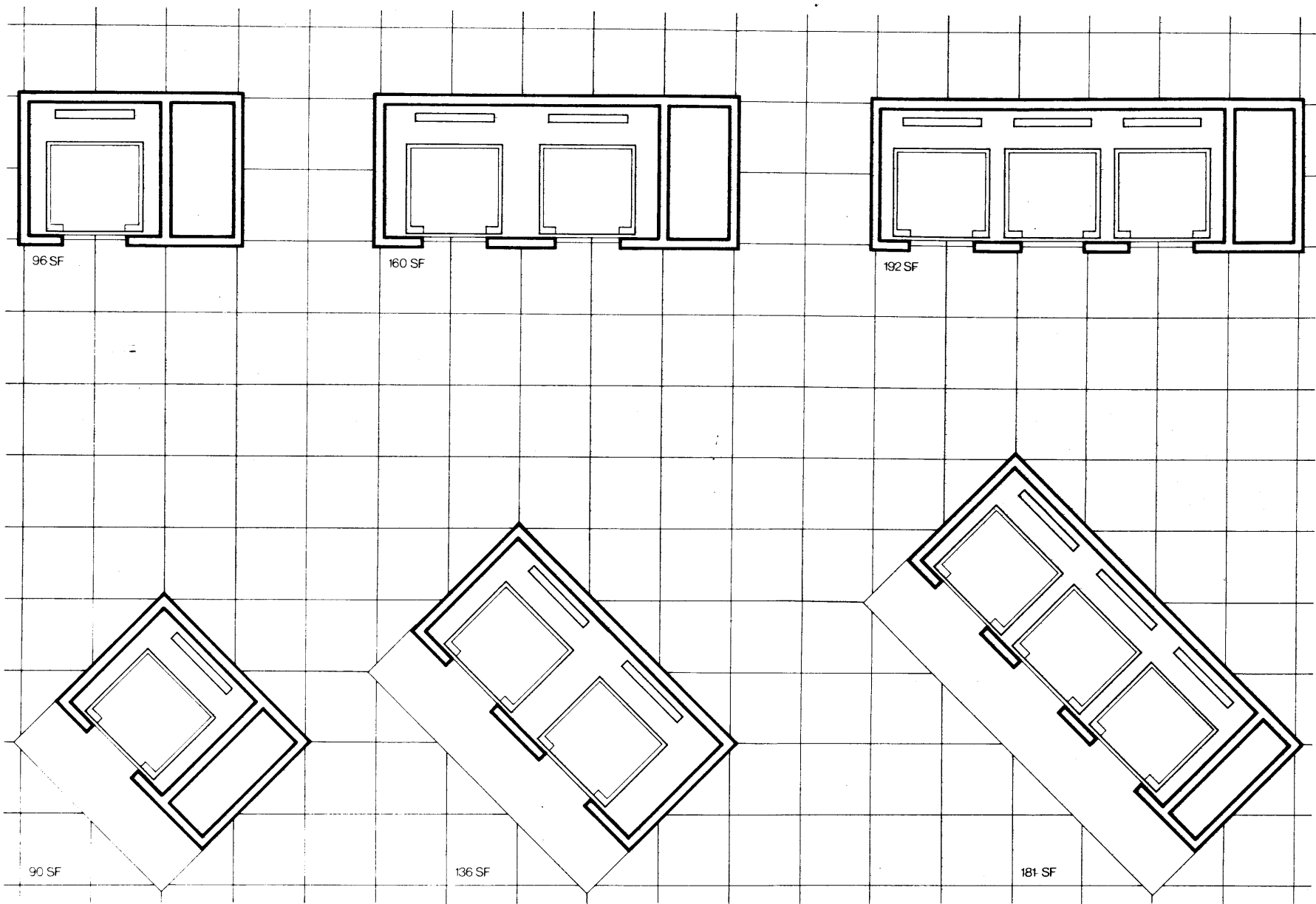

ELEVATORS

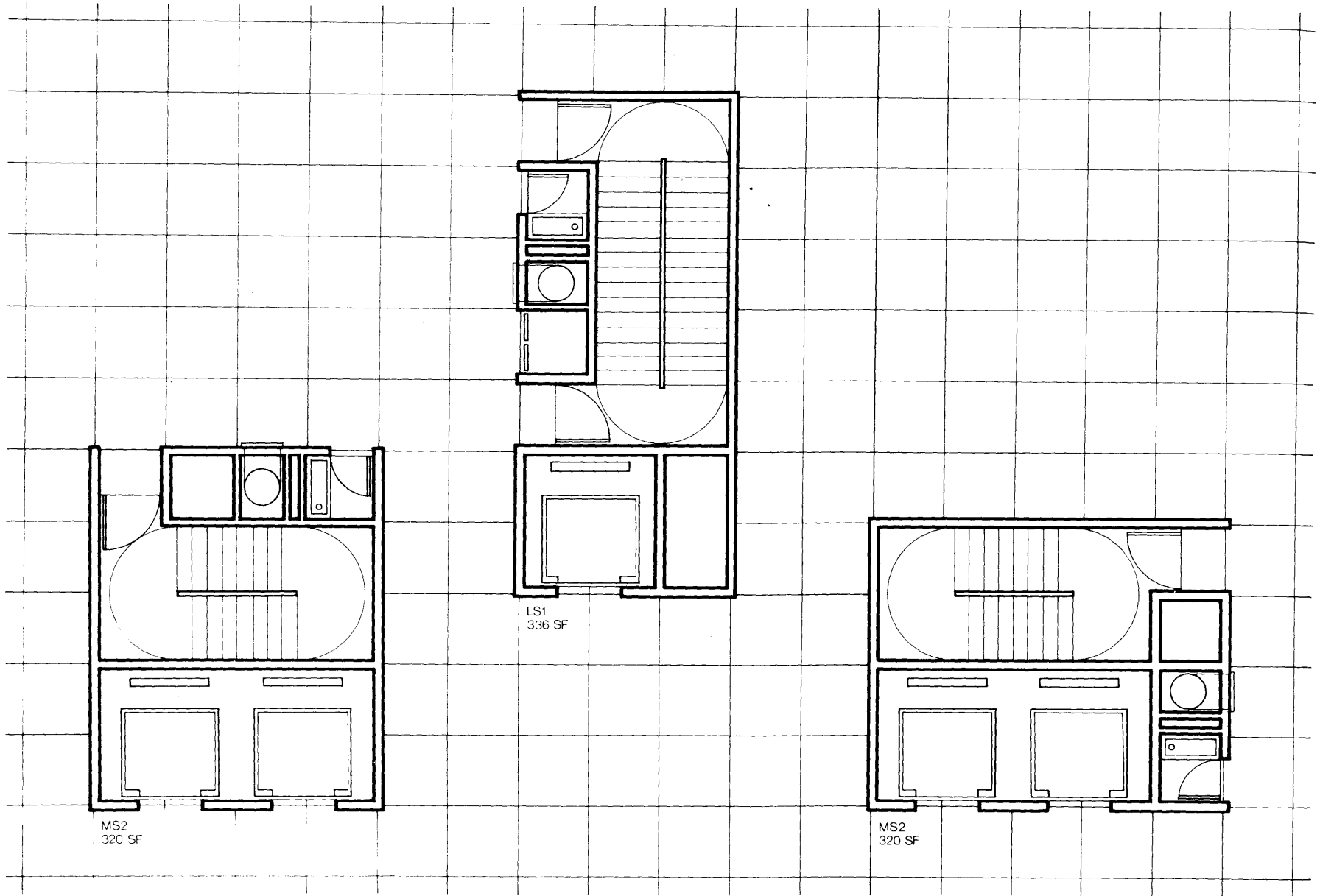

MIDRISE 4-10 STORIES

CORES

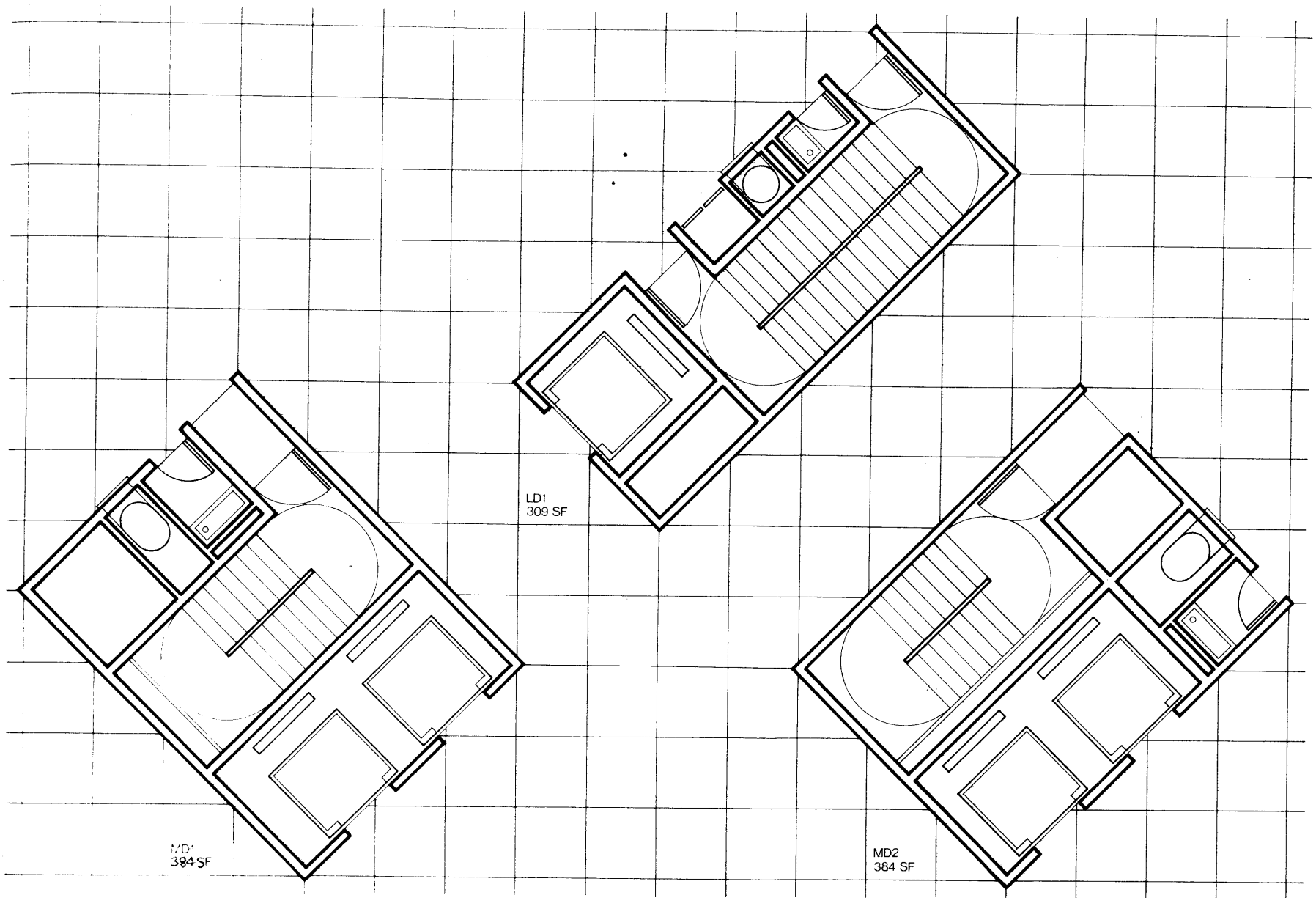

MD1
384 SF

LD1
309 SF

MD2
384 SF

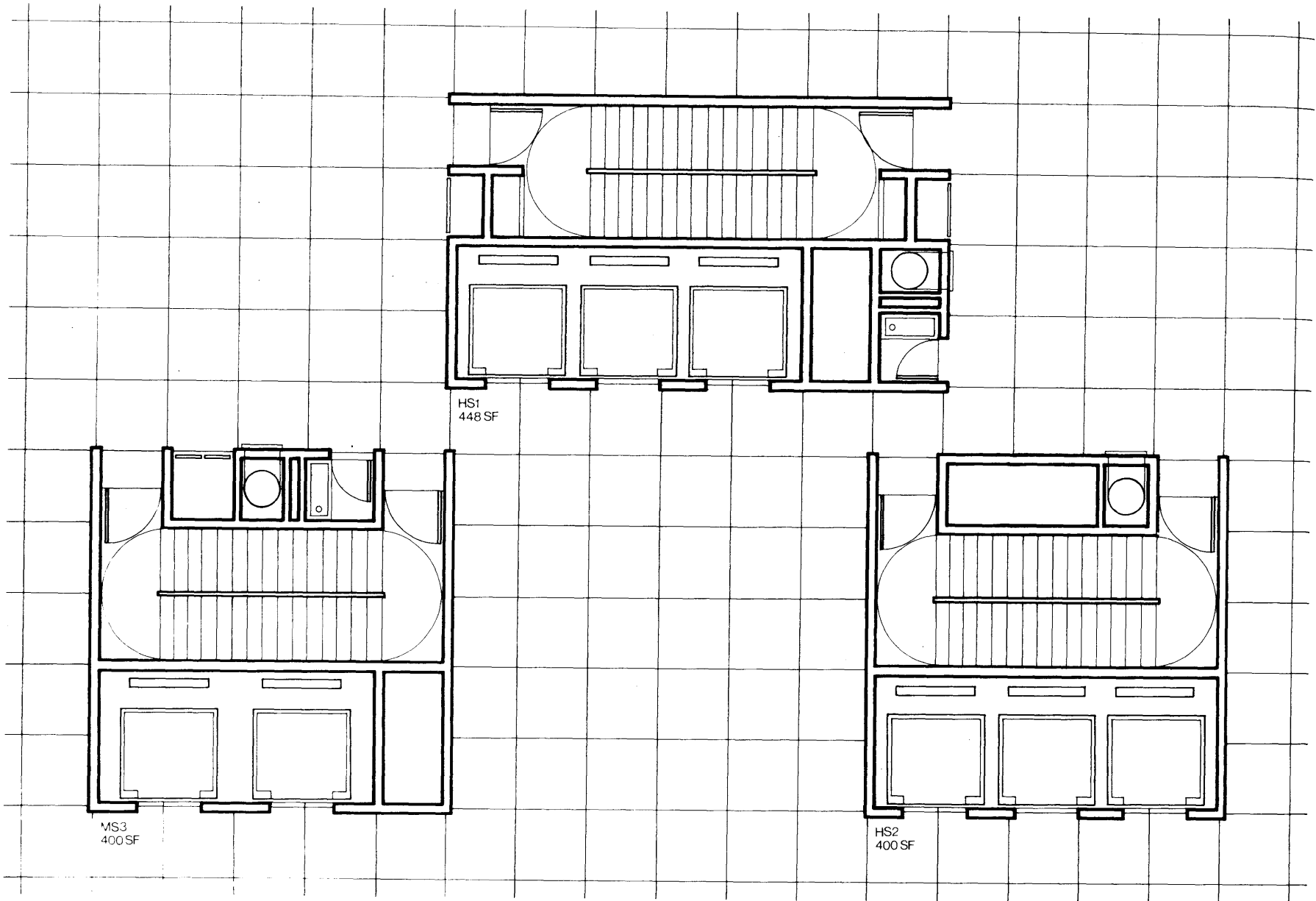

HIGHRISE 10-18 STORIES

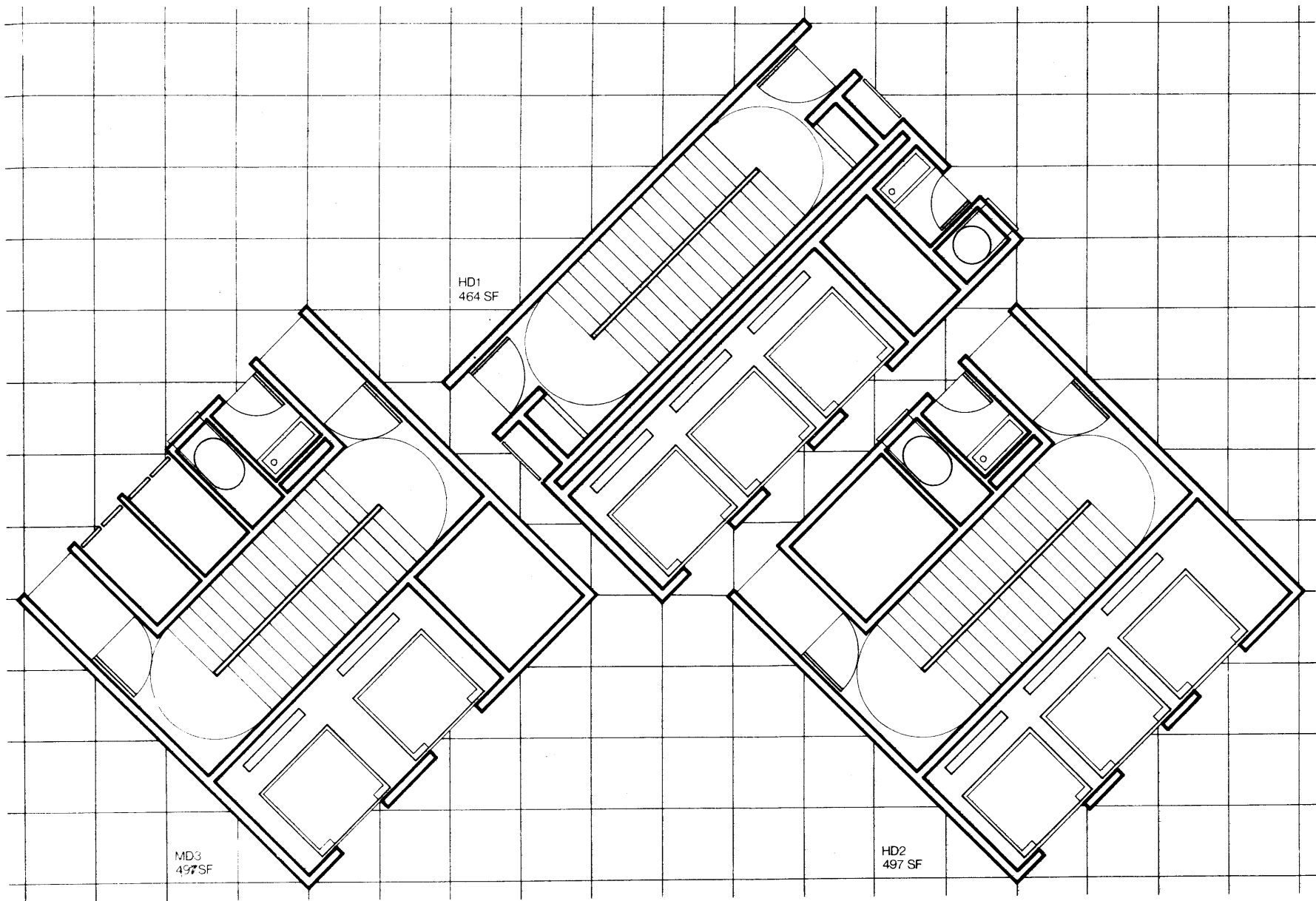

1"-8'

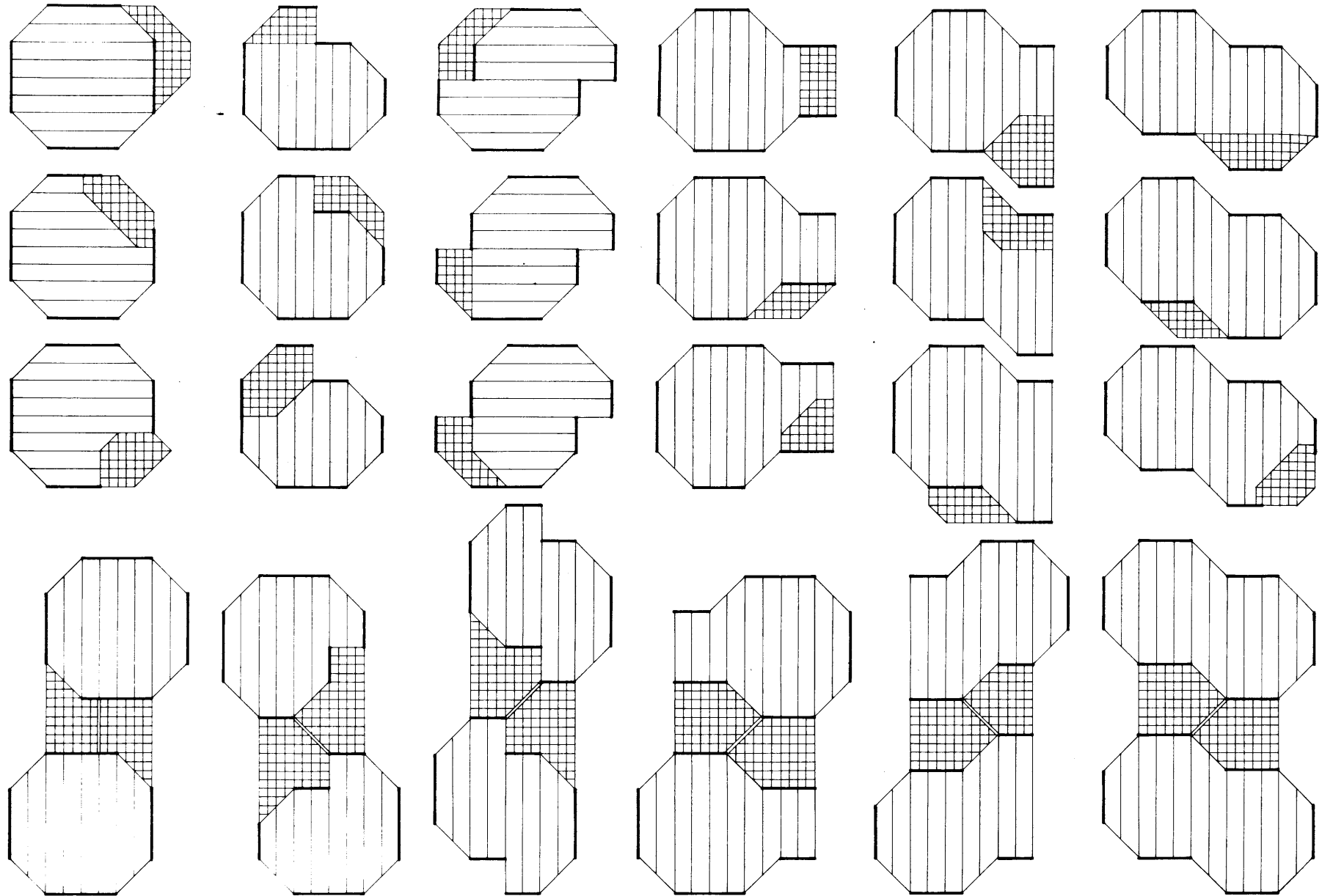

EXTERIOR SPACES

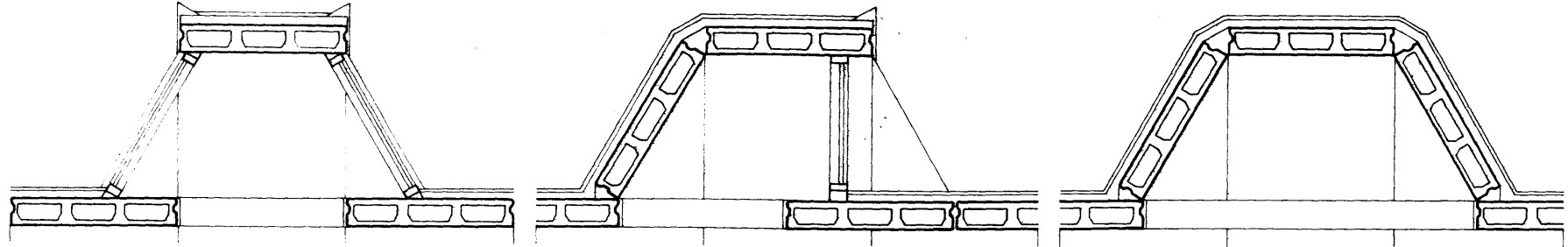

SINGLE PLANK EXTENSION

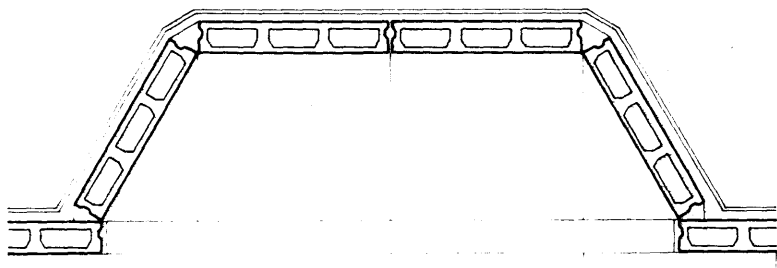
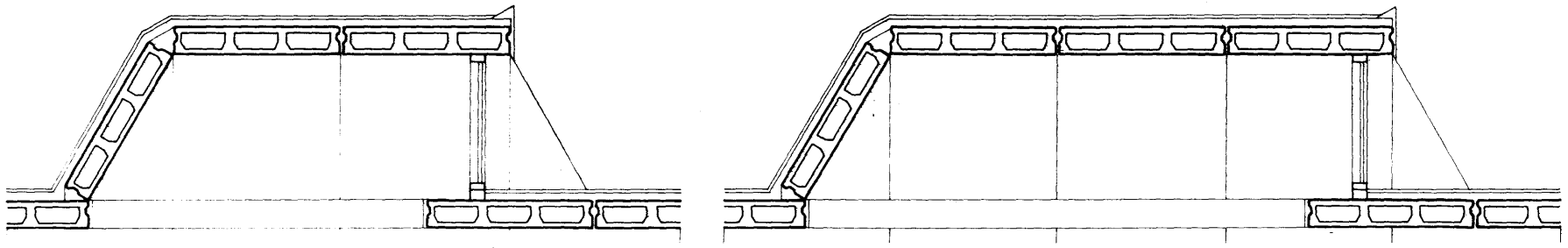
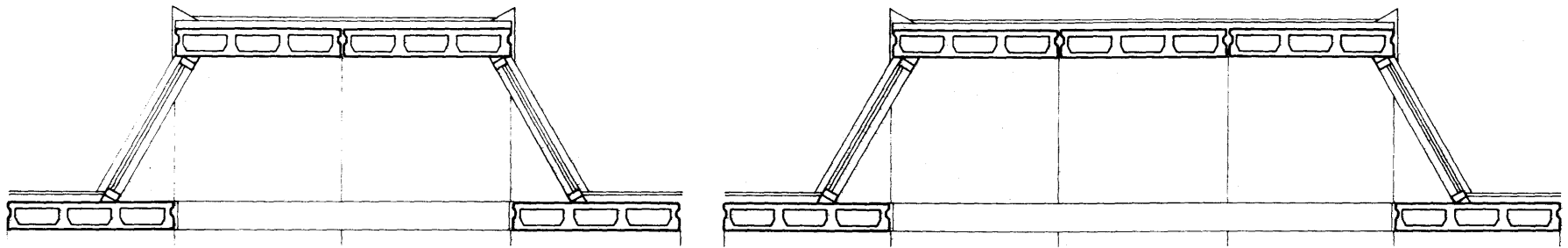

DOUBLE PLANK EXTENSION

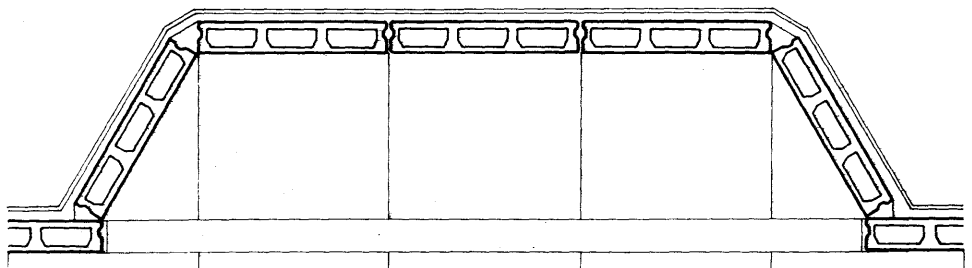

TRIPLE PLANK EXTENSION

ROOF SECTIONS

1"=4'

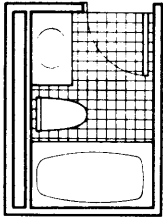

40 SF

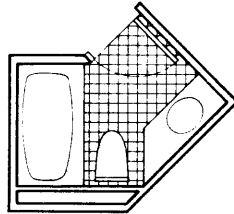

39 SF

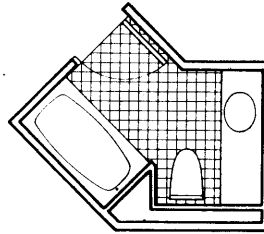

52 SF

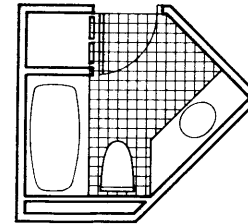

58 SF

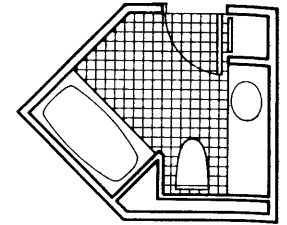

66 SF

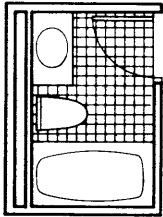

40 SF

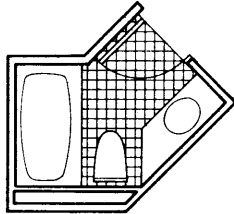

39 SF

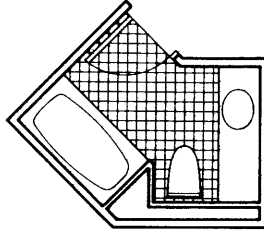

52 SF

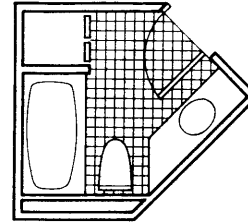

58 SF

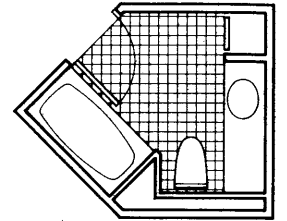

66 SF

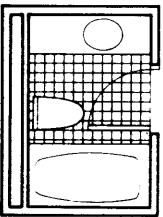

40 SF

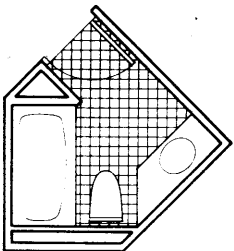

50 SF

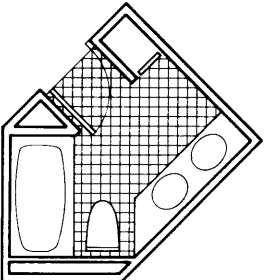

60 SF

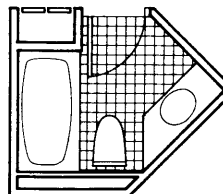

48 SF

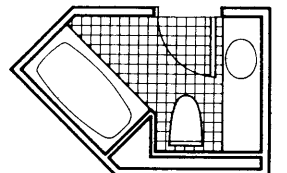

49 SF

BATHROOM OPTIONS

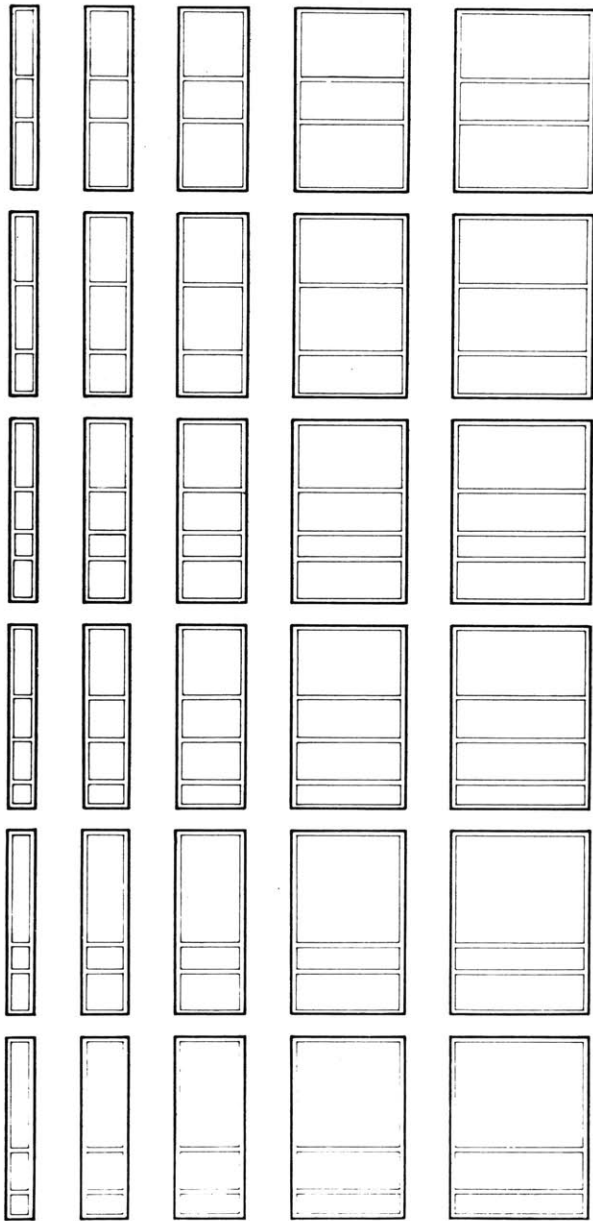

1-0 1-10 2-10 4-6 5-8
 PANEL SIZES & DIVISIONS

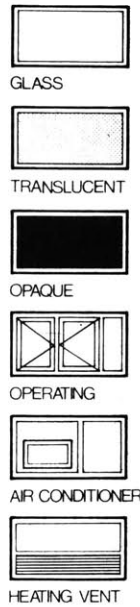

PANEL COMPOSITION

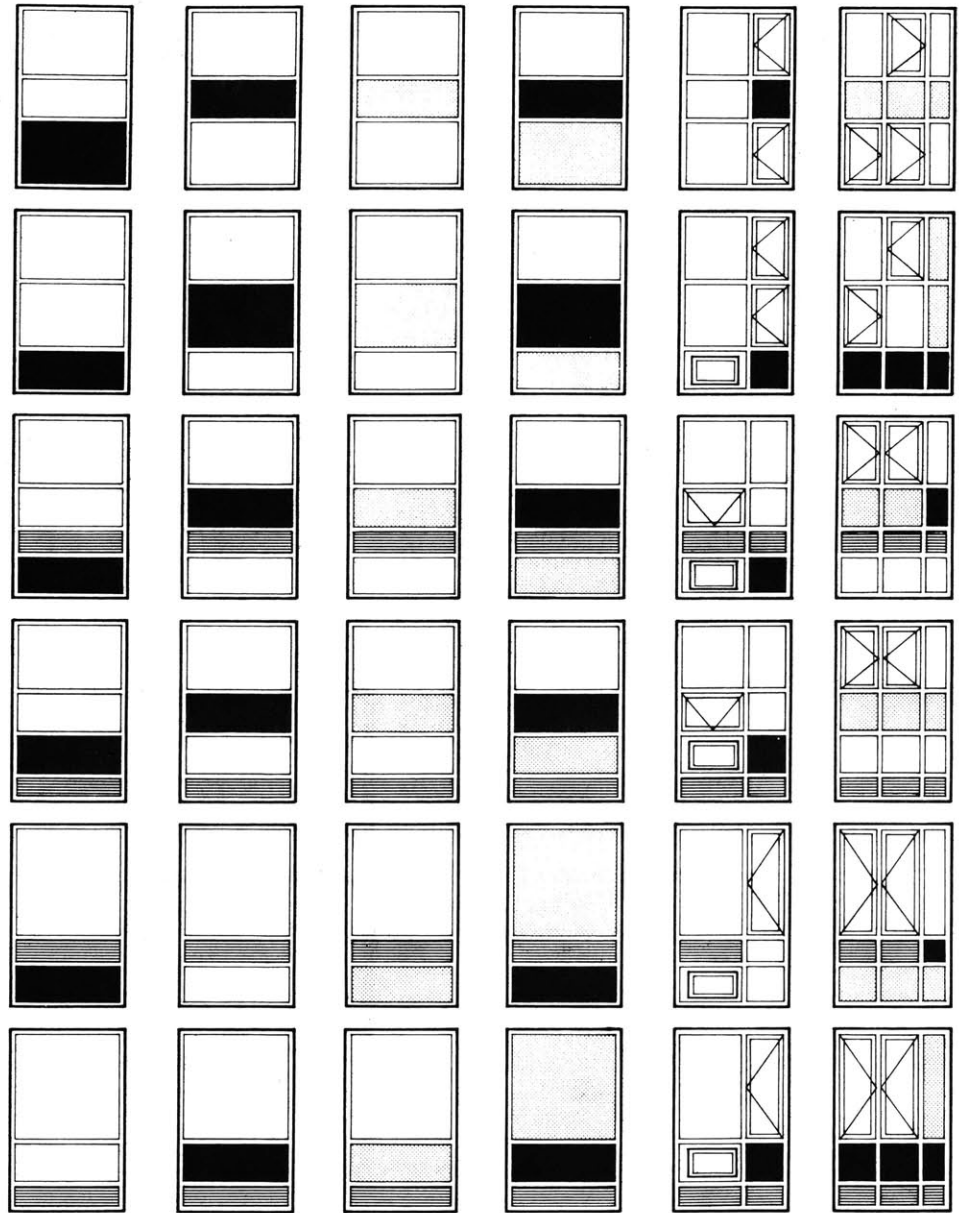

EXTERIOR INFILL PANELS

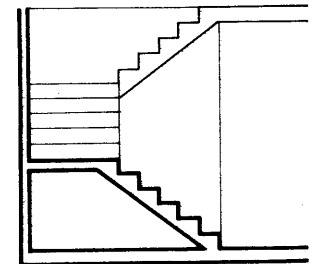
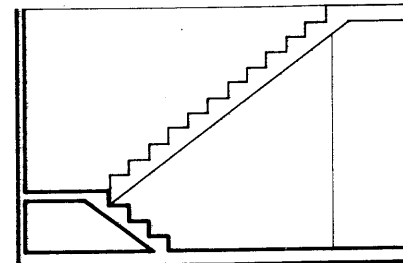
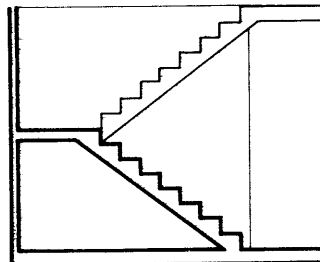
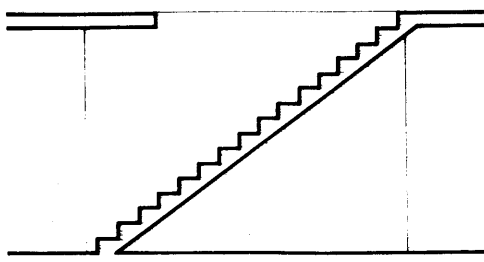
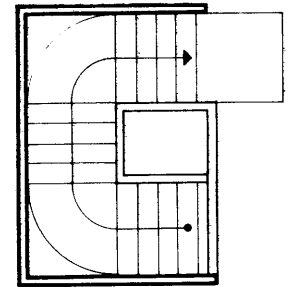
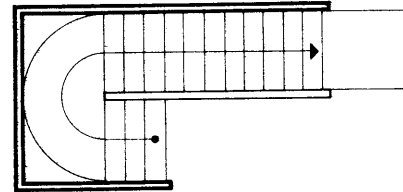
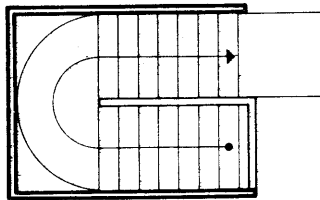
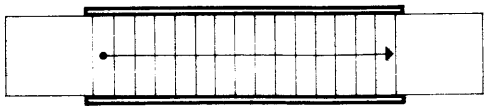
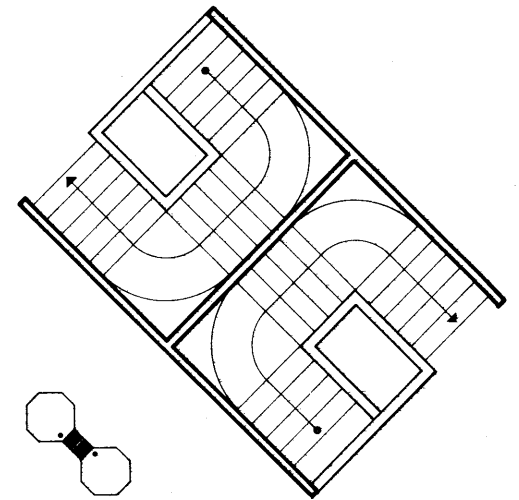
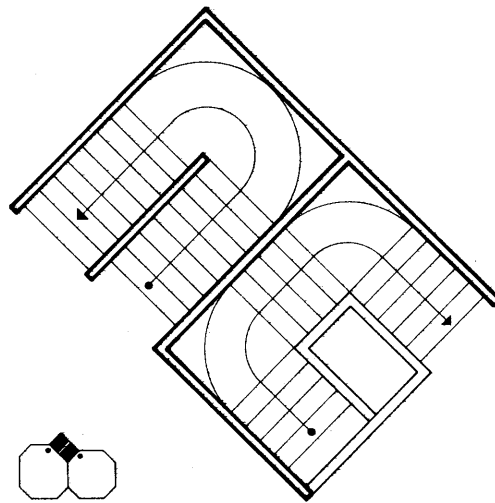
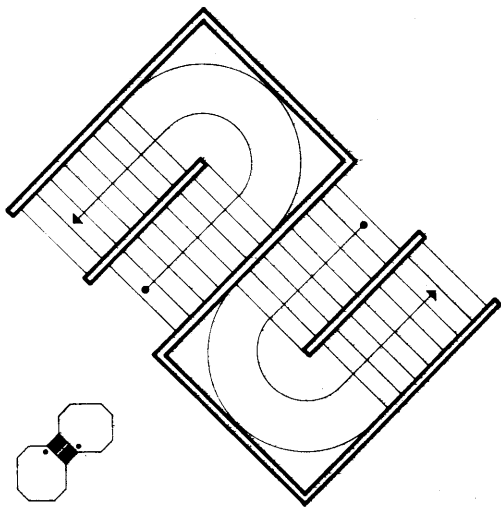

INTERIOR STAIRS

1"-8'

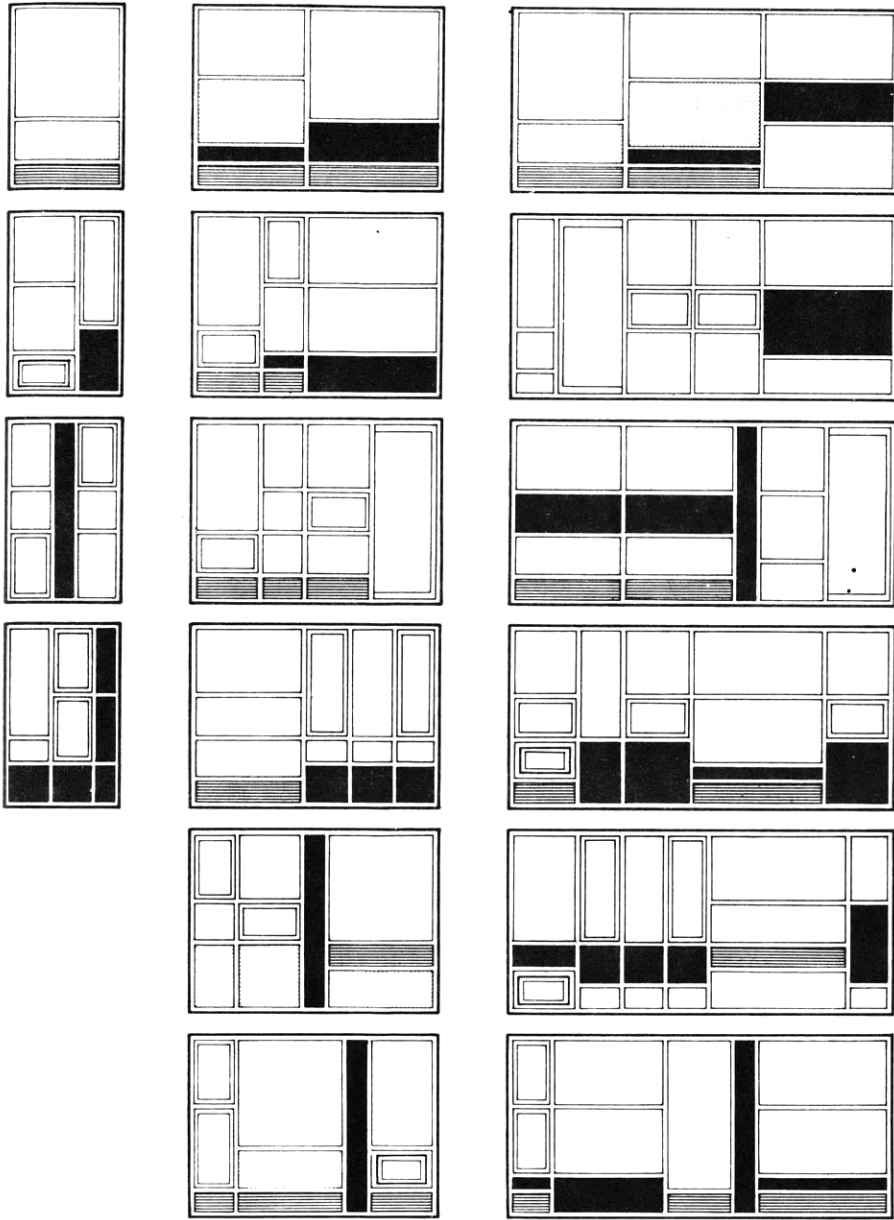

5'-8
DIAGONAL INFILL

PANEL VARIATIONS



4'-0
PERPENDICULAR INFILL

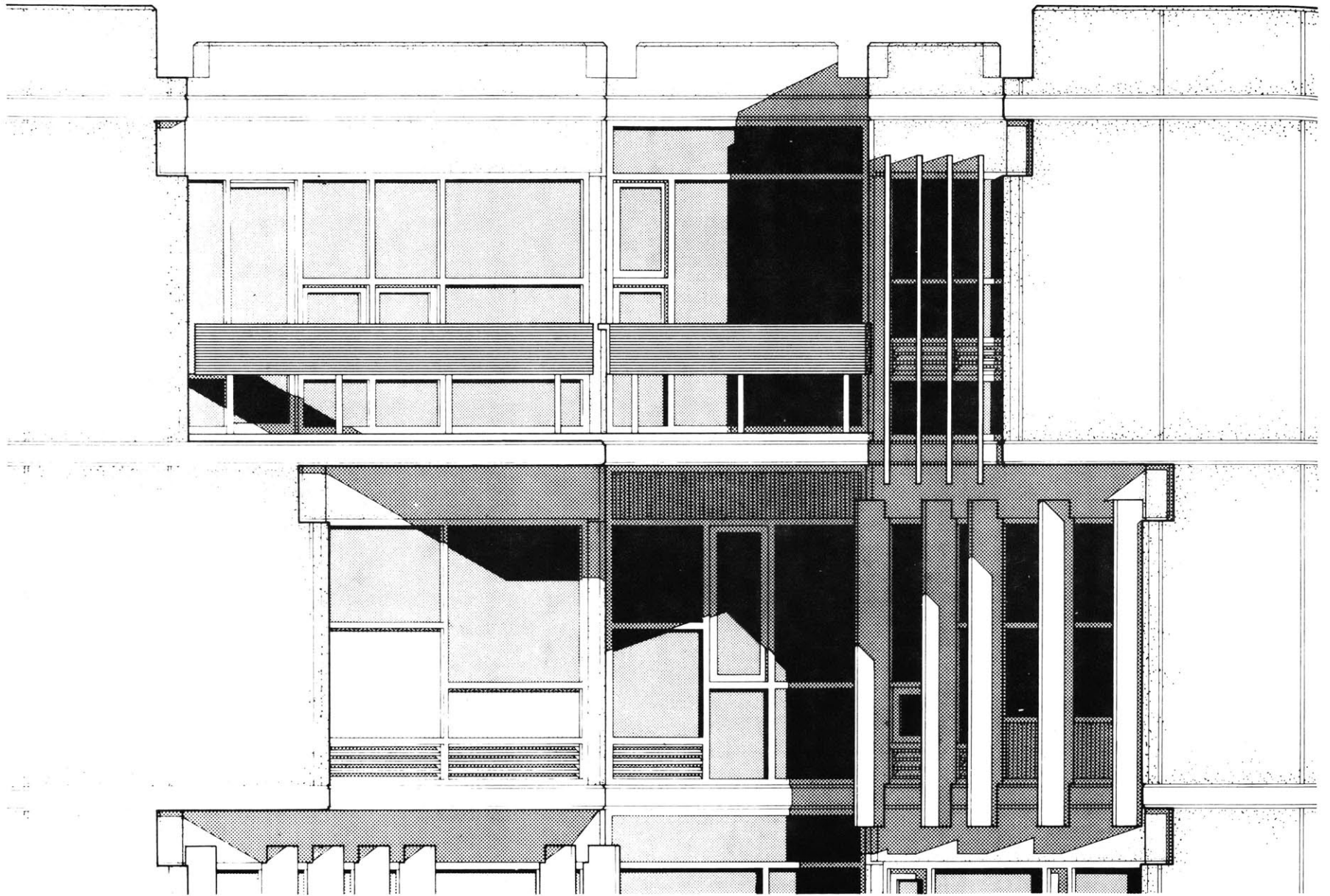

PARTIAL ELEVATION

In the conflict between the quality of the environment and the availability of resources we are drawn to the industrialization of the building process in the hope that it may stimulate a solution. In recent years a great number of industrially produced solutions have been proposed to help meet the needs of rapidly growing urban populations. These solutions have introduced the advantages of modern manufacturing in an effort to increase the volume of production and to decrease labor costs. These solutions have also caused concern for the poor quality of the environment which has been achieved.

There is an inherent danger within the industrialized building process. This process is based on repetition and standardization. Too often the result is a monotonously repetitive and standardized inhumane environment. The result is that

every unit has the same interior plan, orientation and finishes, and every group of units the same organization, form and scale. Also, because of transportation restrictions on factory-assembled dwelling units, the spaces within units suffer from fixed dimensions and opening locations.

A housing system must allow within the dwelling unit a sense of spaciousness, adaptability, identity. To achieve these goals the system must at some point afford a freedom in planning, becoming only a means to a desired goal. The constraints which form the system must not dictate automatically the composition and organization of the built environment. Because of these aspects there is a need for industrially produced systems which are more neutral in their influence and more variable in their composition and application.

UNIT PLANNING & CLUSTER MORPHOLOGY

This table represents a proposal for increasing the size of dwelling units incrementally from the proposed minimum square footages to more generous areas.

Minimum square footages are established for each room or space and added together to make up the dwelling unit. These minimums are formulated from minimums established by three governmental agencies: H.U.D., U.D.C. and H.R.A. Too often architects and builders receive these minimums as desirable goals in the design of housing. Because of this the minimum areas do a disservice to the quality of interior planning.

The minimum areas represent a starting point for establishing a range of area sizes within a unit type. Each room or space is assigned an increment of increase. The increment is derived as a division between the absolute minimum square footage required and the comfortable average square footage desirable for the same space. This addition of square footage to the minimum produces a range of five increasing volumes, with the fifth being an

area which is generous for the function of the space.

The minimum square footage for each space increases in one, two, three and four bedroom units. The increments that increase these minimums change with respect to the average square footage required for each space. Circulation allowance also increases with respect to unit type. Studios and one bedroom units, being the least formal, require less circulation. And four bedroom units, being more formal, require more circulation. Circulation is reflected as a percentage of the total unit square footage.

This study allows the designer and the builder to focus more on the production of average size units. This results in greater livability and adaptability within the unit. It also promotes variety in unit types so that a potential inhabiting family may choose a two bedroom unit with a size appropriate to their needs. There is also the possibility of choice between a large two bedroom unit or a smaller three bedroom unit.

- I • Increment Increase
- M • Minimum Square Footage
- A • Average Square Footage
- G • Generous Square Footage

UNIT AREA STUDY

	STUDIO				ONE					TWO					THREE					FOUR								
	I	M	A	G	I	M	A	G	I	M	A	G	I	M	A	G	I	M	A	G								
LIVING SPACE	30	190	220	250	20	140	160	180	200	220	20	160	180	200	220	240	20	200	220	240	260	280	20	200	220	240	260	280
DINING SPACE					15	85	100	115	130	145	15	85	100	115	130	145	10	100	110	120	130	140	10	100	110	120	130	140
KITCHEN	15	100	115	130	8	60	68	76	84	92	10	70	80	90	100	110	8	100	108	116	124	132	8	100	108	116	124	132
BEDROOM PRI.					10	110	120	130	140	150	10	110	120	130	140	150	10	110	120	130	140	150	10	110	120	130	140	150
BEDROOM SEC.																												
BEDROOM SEC.																												
BEDROOM SEC.																												
BATHROOM	25	35	38	40	25	35	38	40	43	45	5	40	45	50	55	60	7.5	48	56	63	71	78	6	56	62	68	74	80
CLOSET SPACE	2	12	13	14	2	16	18	20	22	24	3	25	28	31	34	37	4	34	38	42	46	50	5	40	45	50	55	60
CIRCULATION PER.					5%	21	24	28	30	33	8%	46	52	58	64	70	10%	78	86	94	102	110	10%	97	106	115	124	133
TOTAL UNIT AREA		337	388	434		467	528	589	649	709		626	706	784	863	942		86	948	1036	1124	1212		1072	1170	1268	1366	1464

INCREMENTAL UNIT AREAS

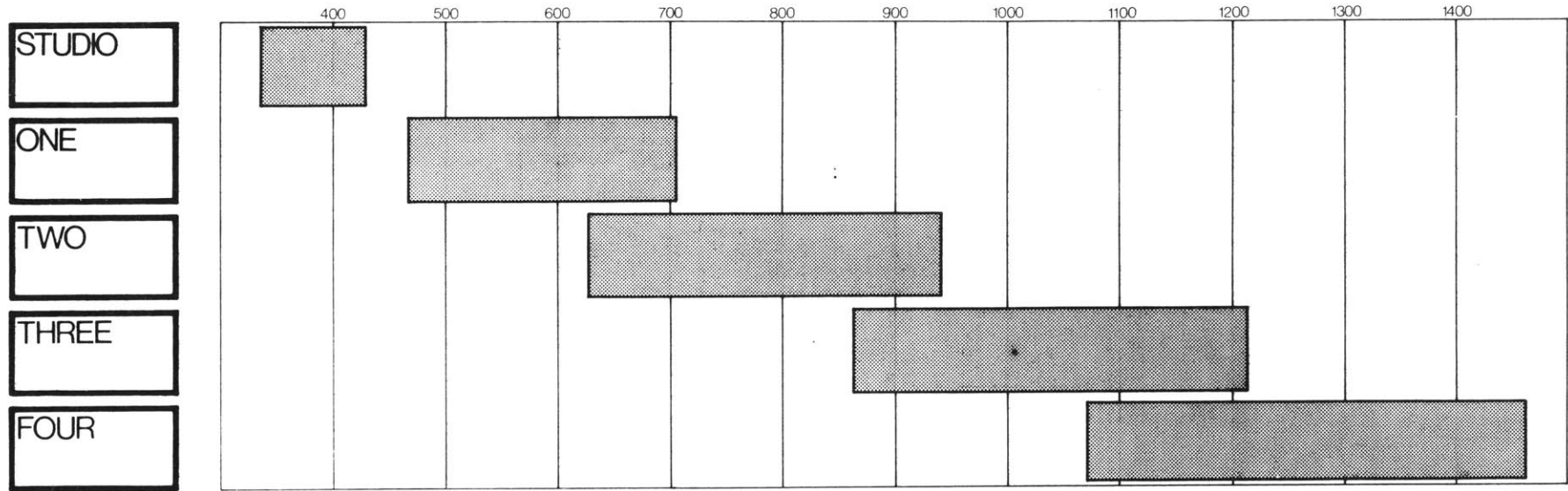

UNIT AREA RANGES

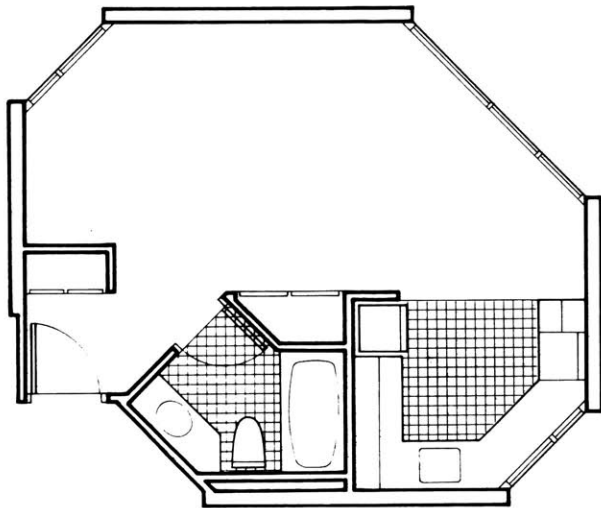

400 SF
STUDIO UNITS

UNIT PLANNING

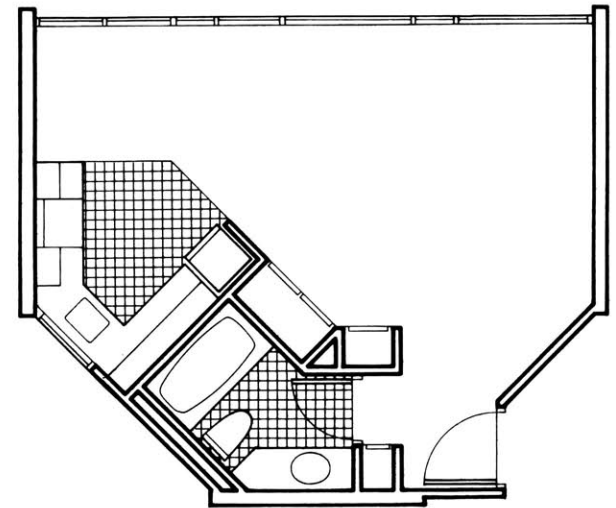

416 SF

1"=8'

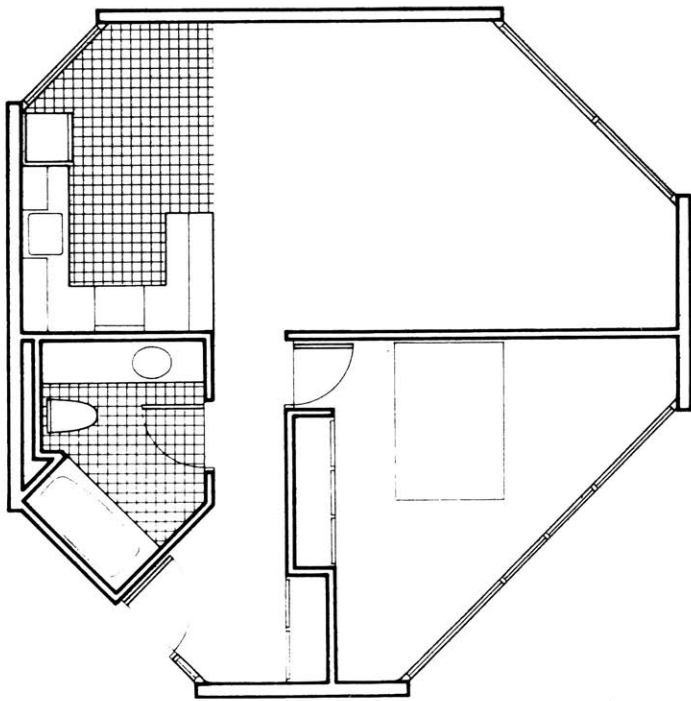

640 SF
ONE BEDROOM UNITS

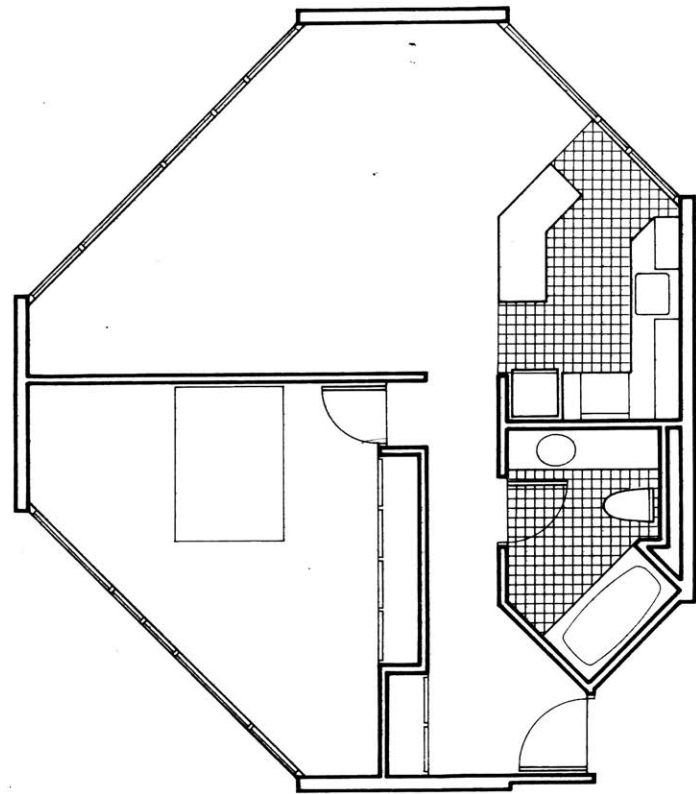

688 SF

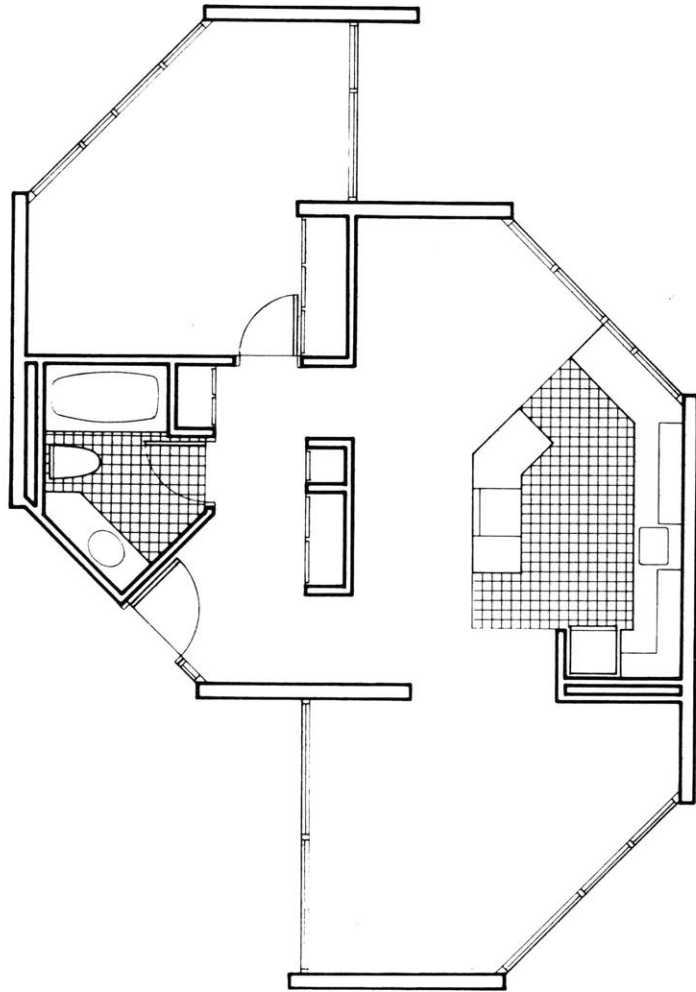

752 SF

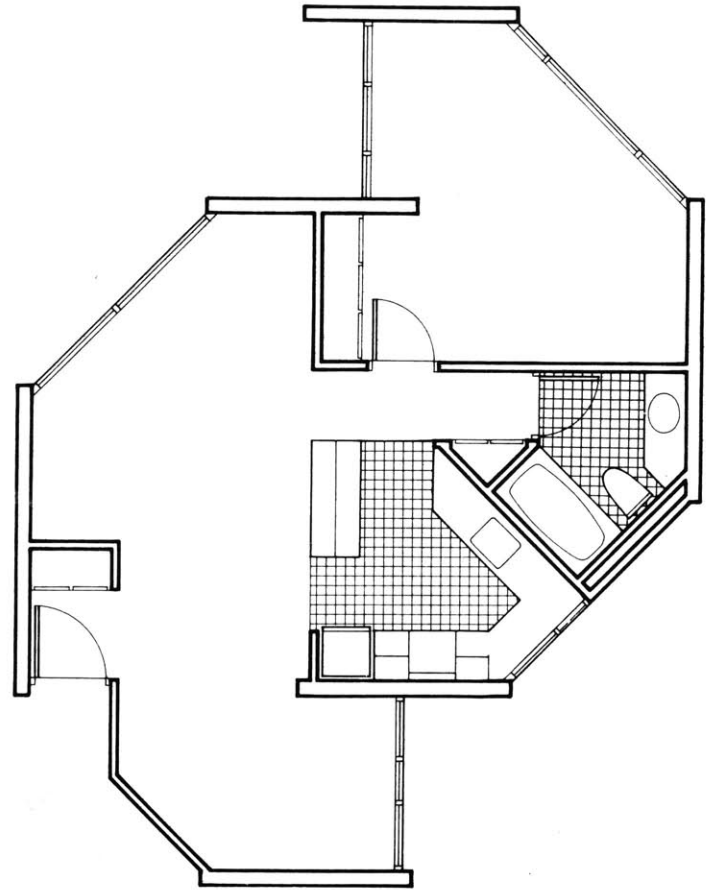

688 SF

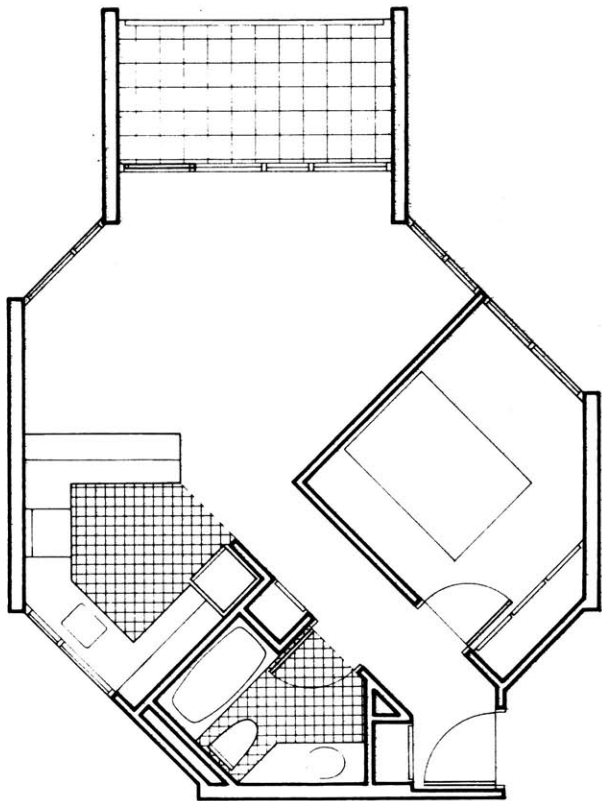

568 SF

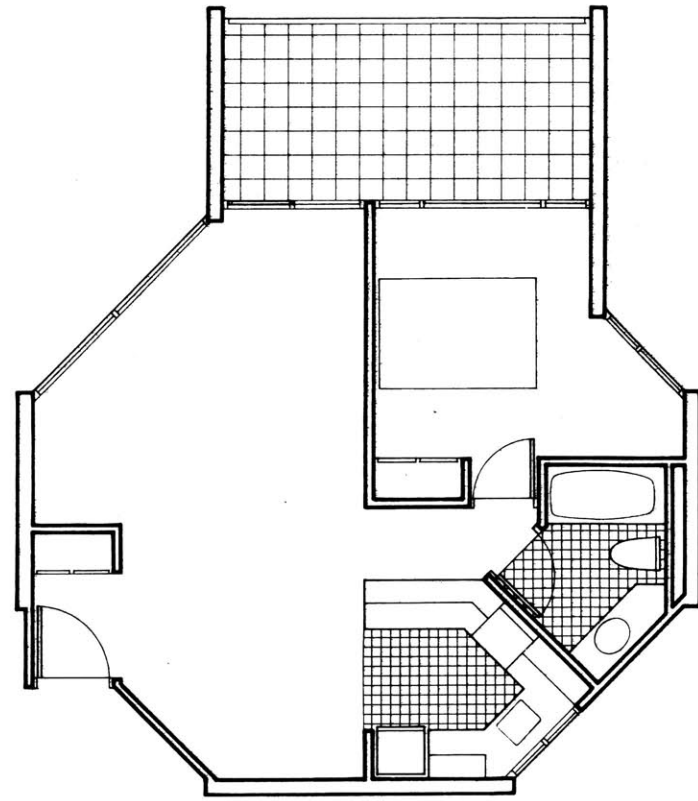

680 SF

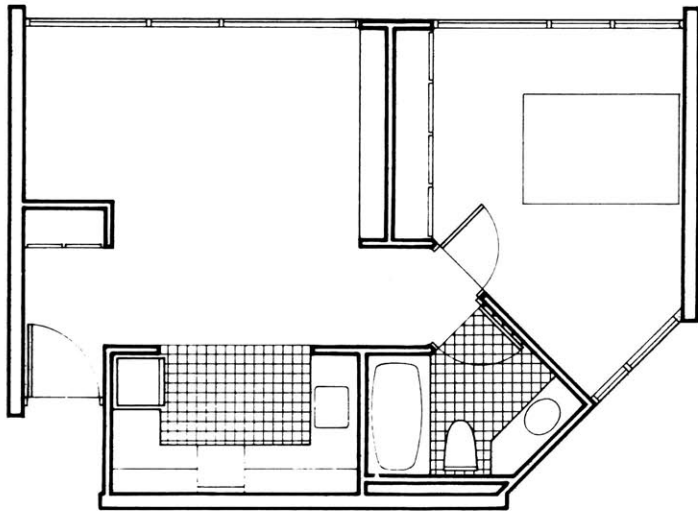

520 SF

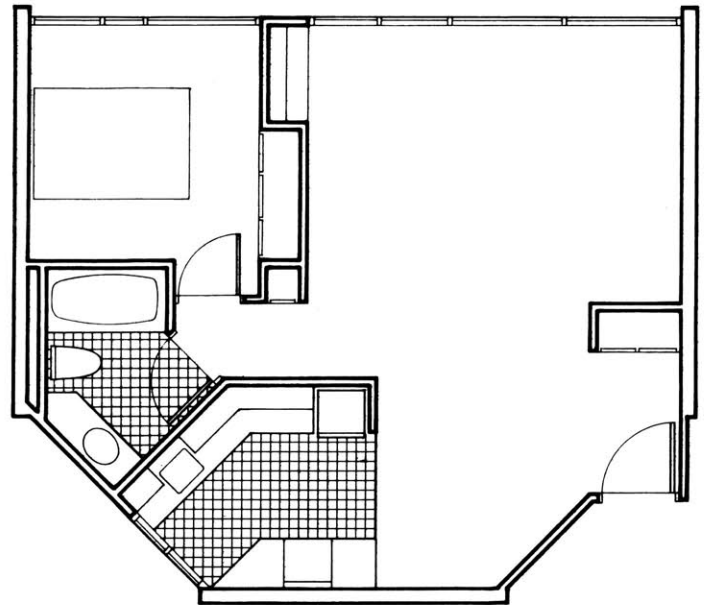

544 SF

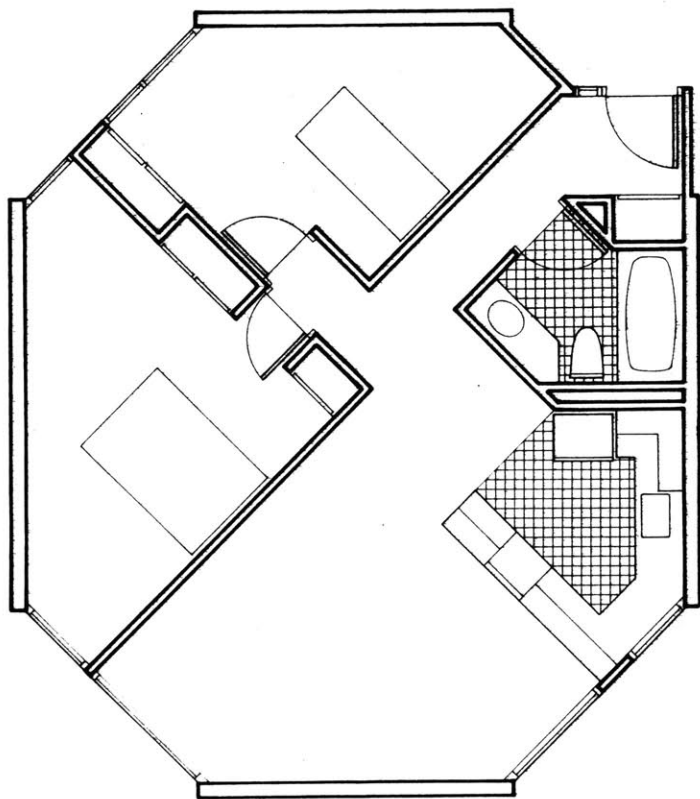

768 SF
TWO BEDROOM UNITS

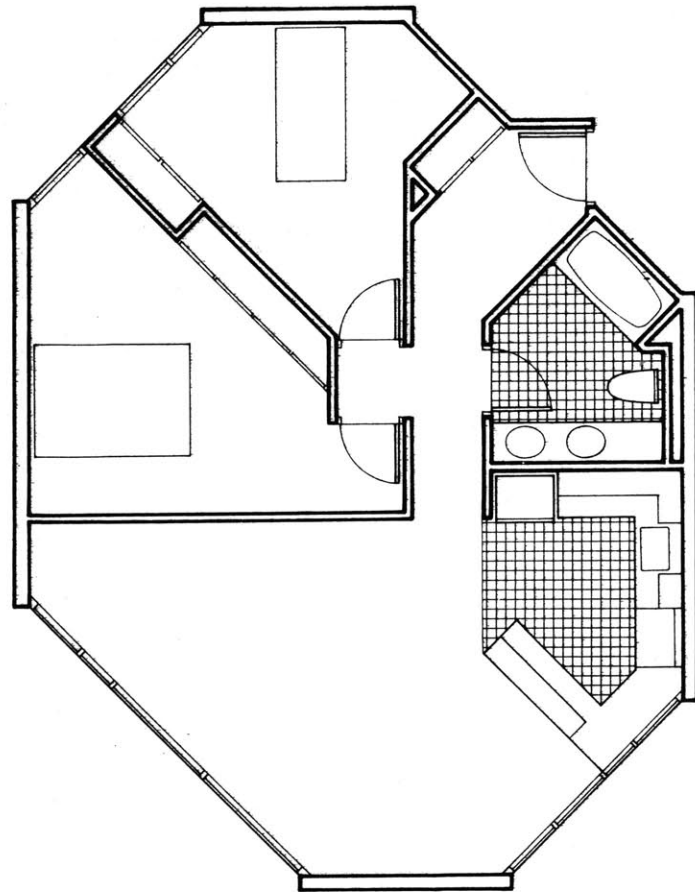

816 SF

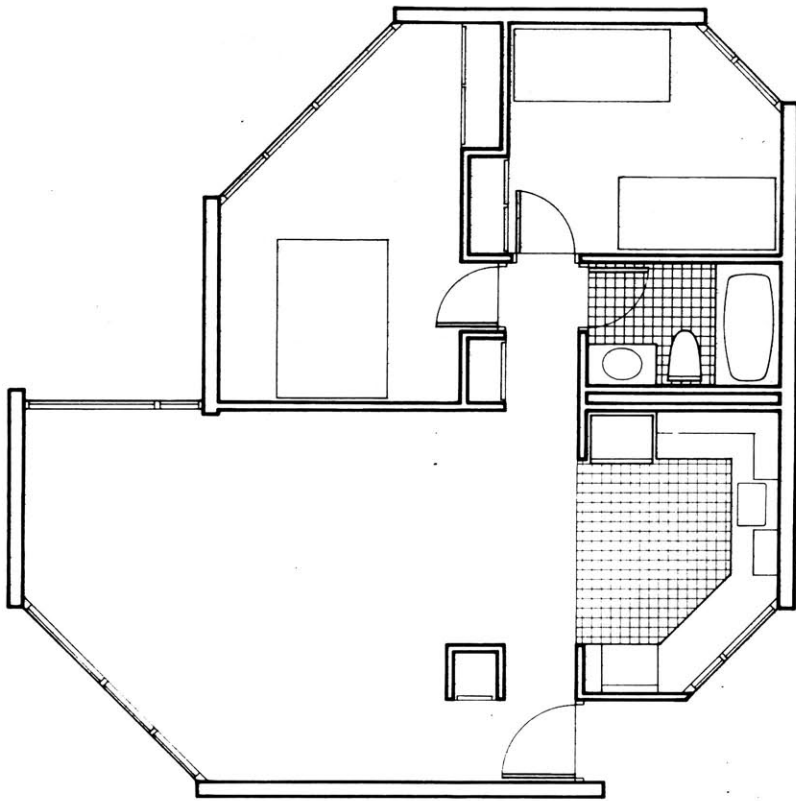

768 SF

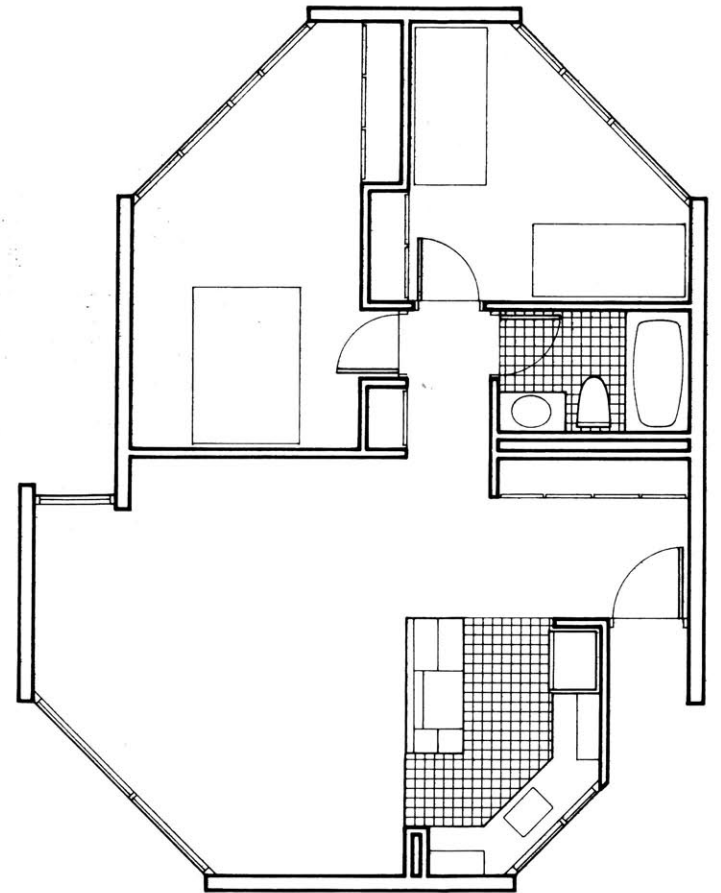

800 SF

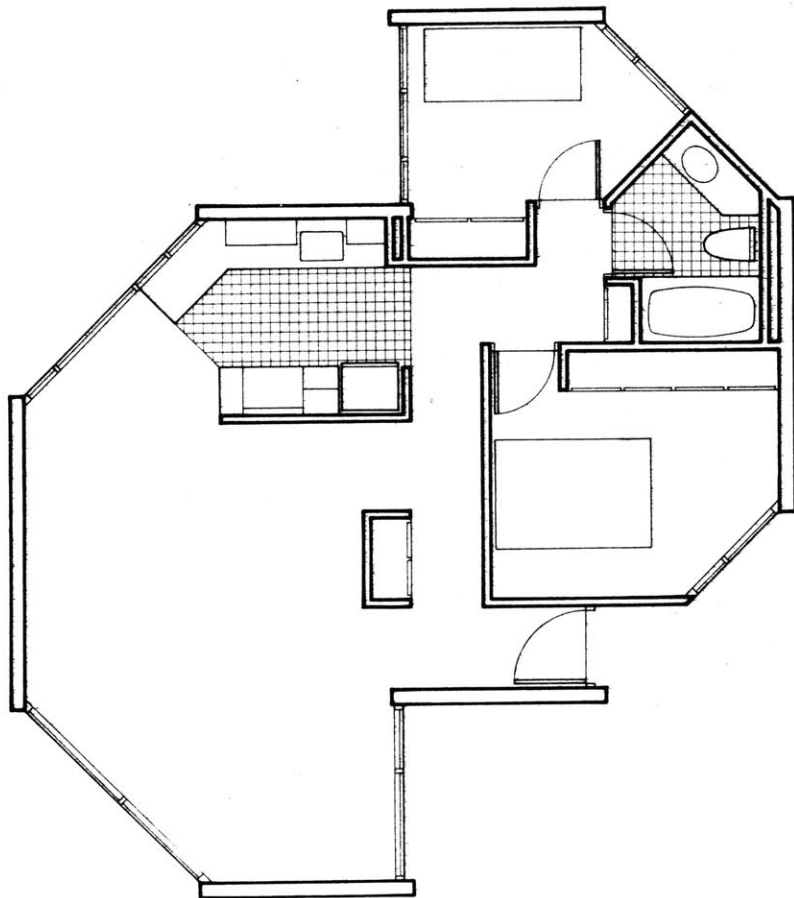

768 SF

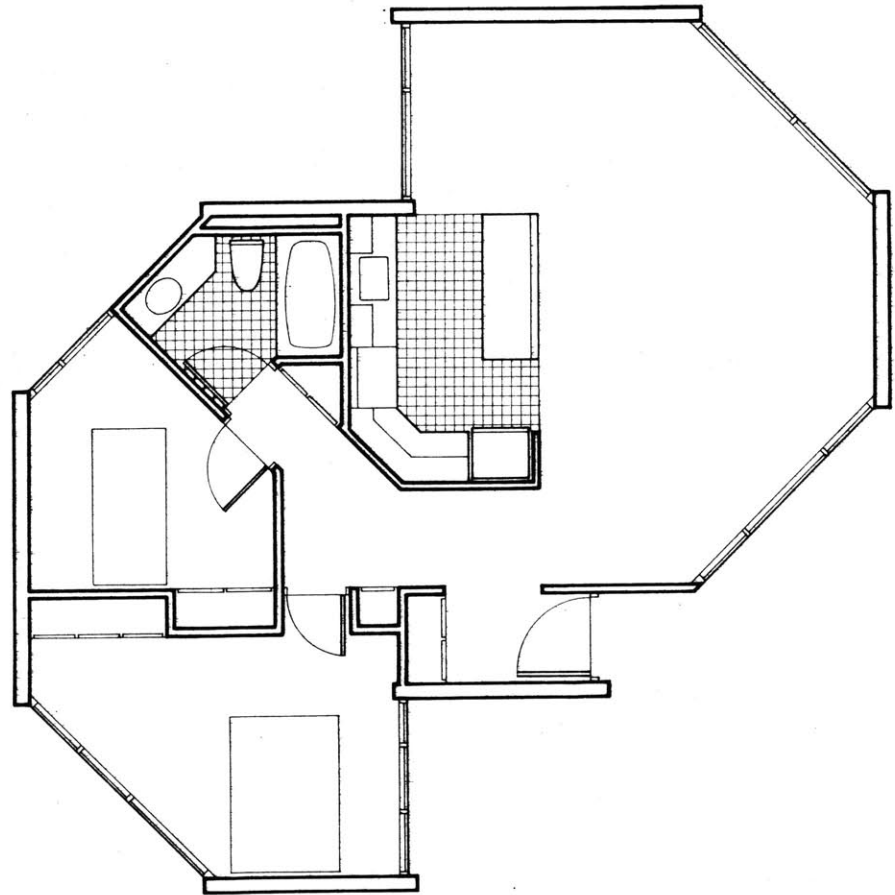

840 SF

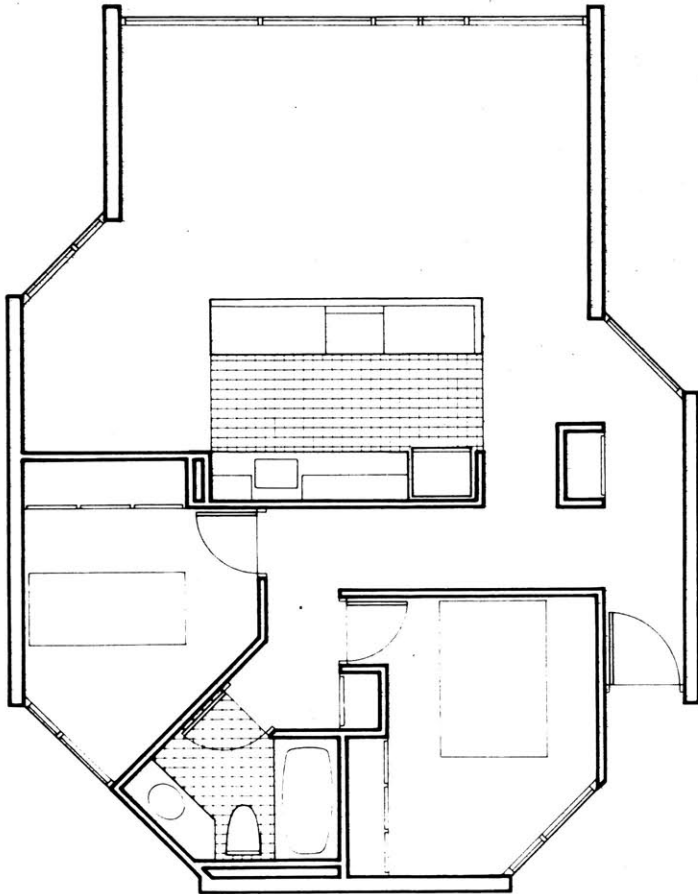

848 SF

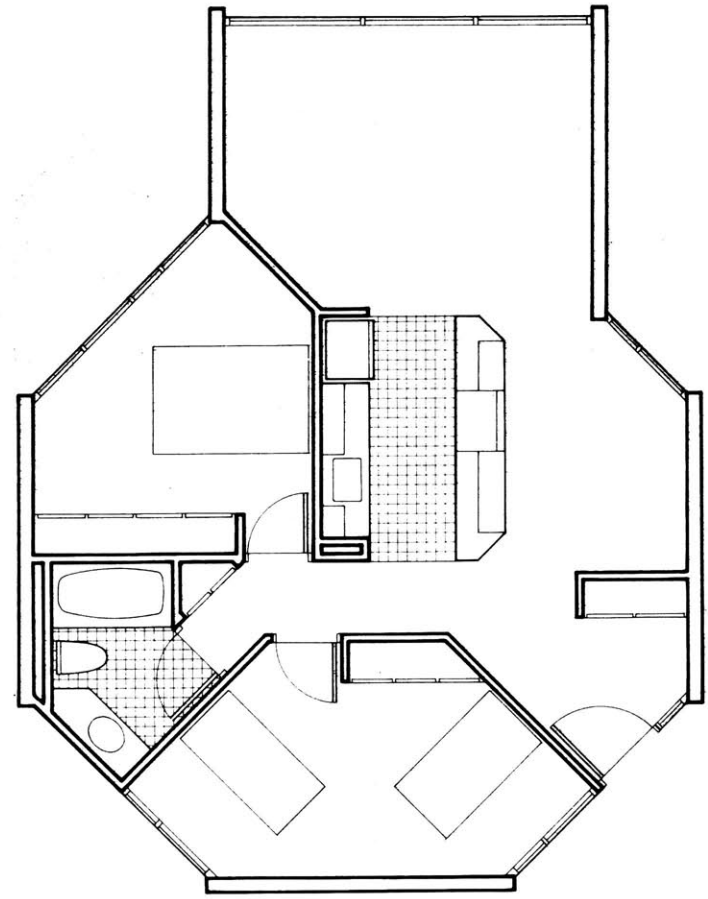

794 SF

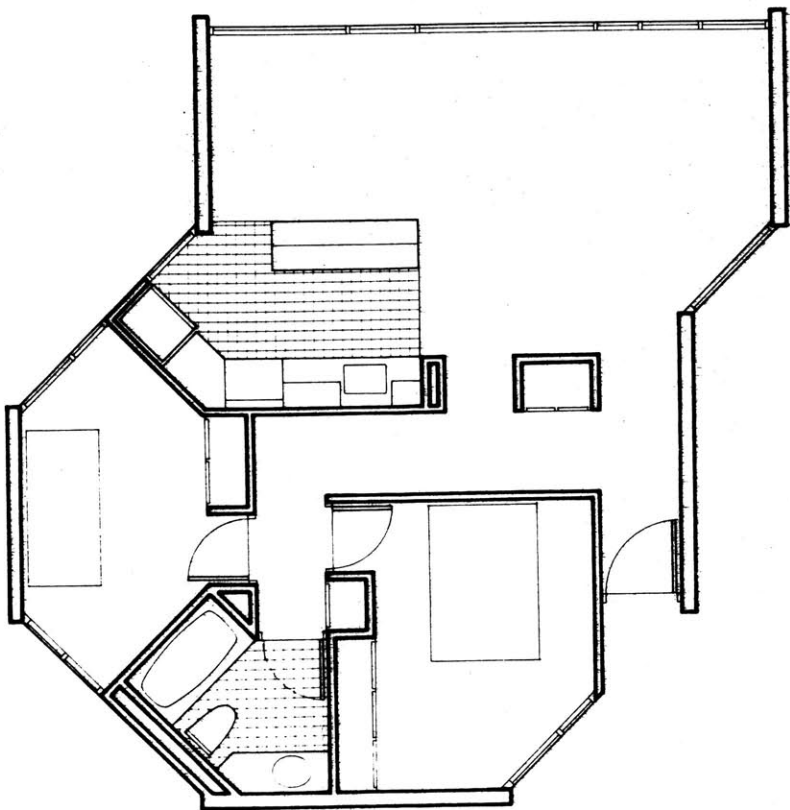

804 SF

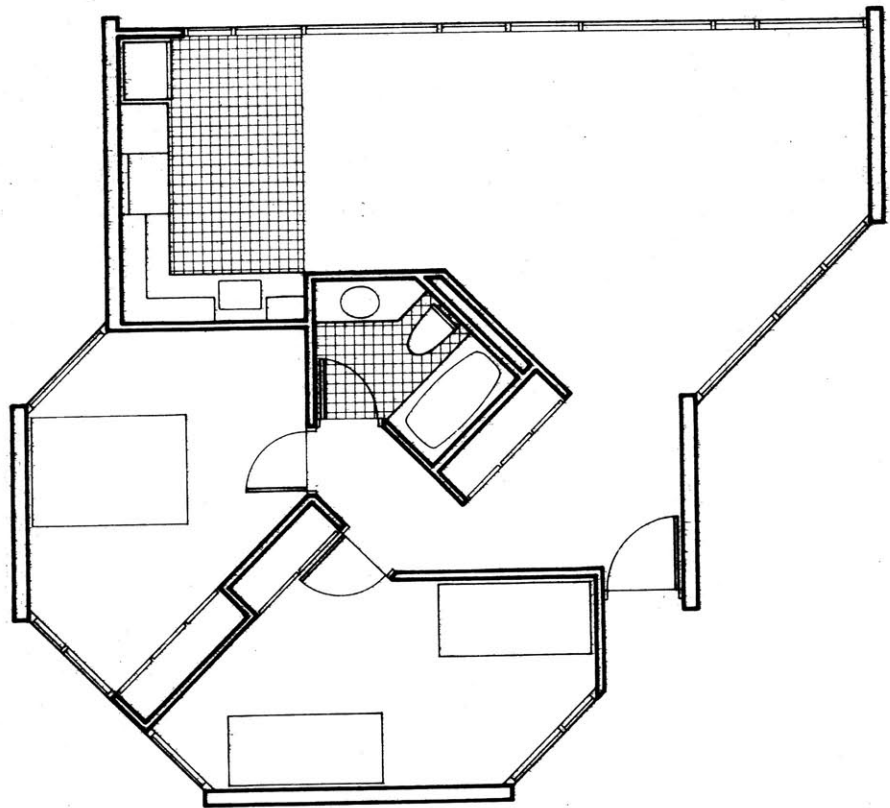

872 SF

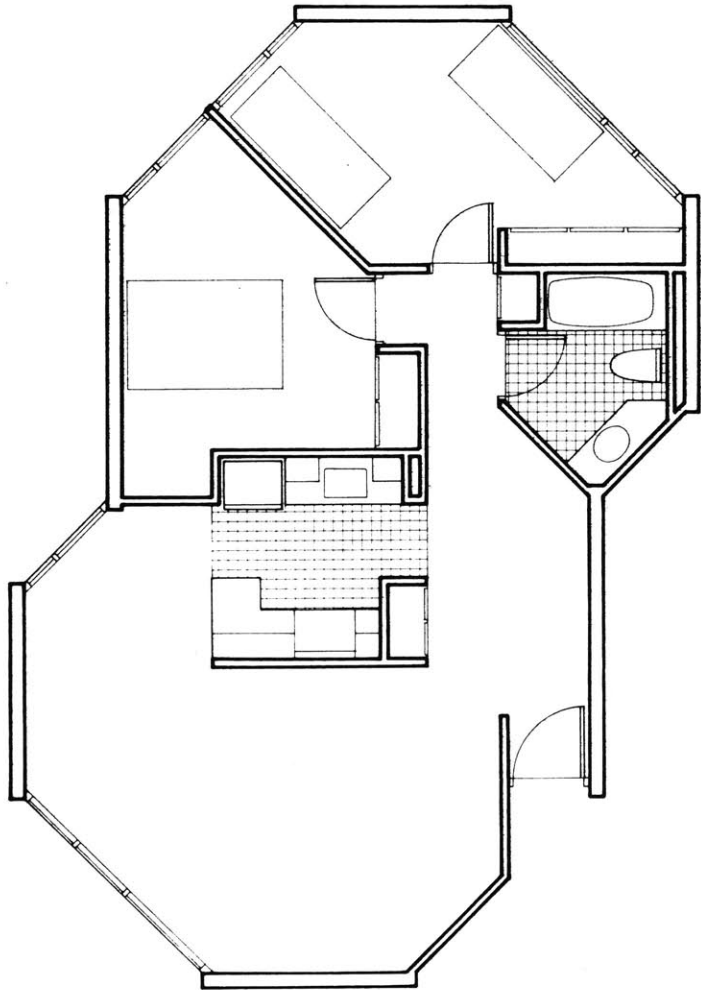

832 SF

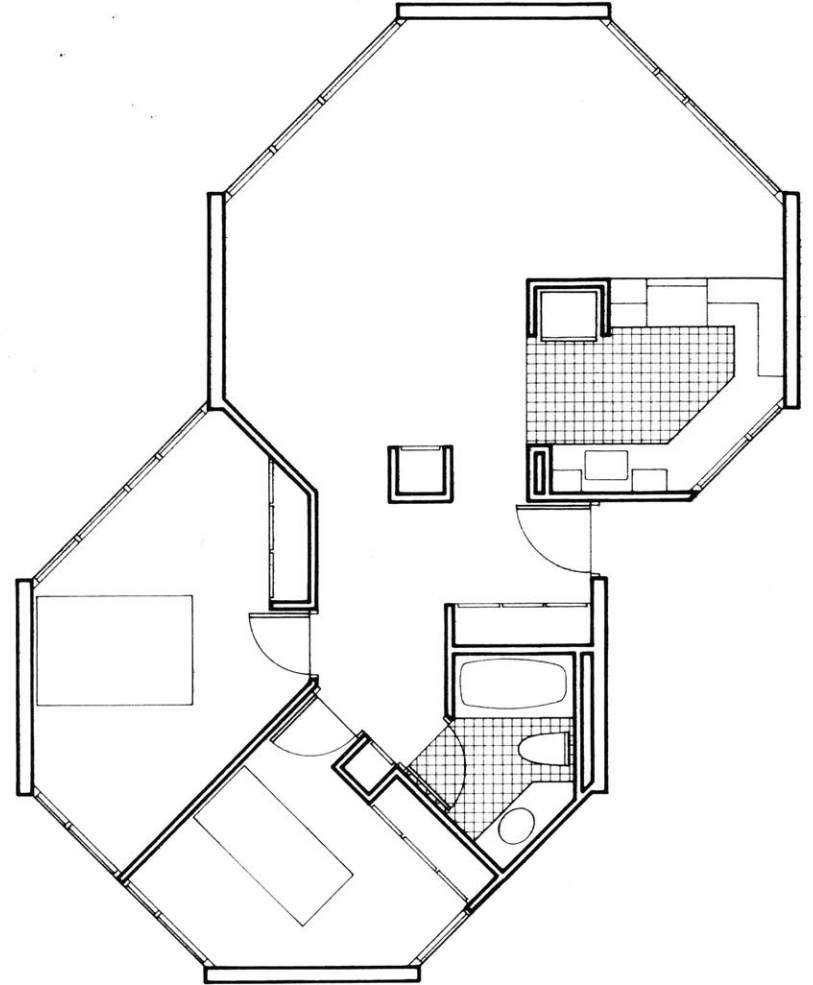

832 SF

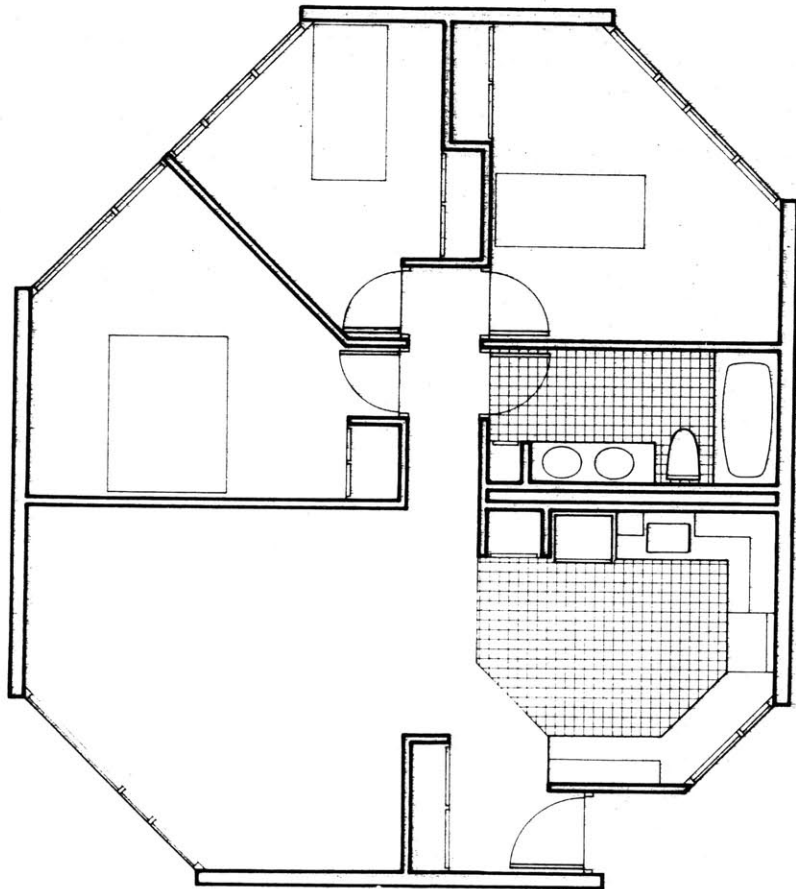

964 SF
THREE BEDROOM UNITS

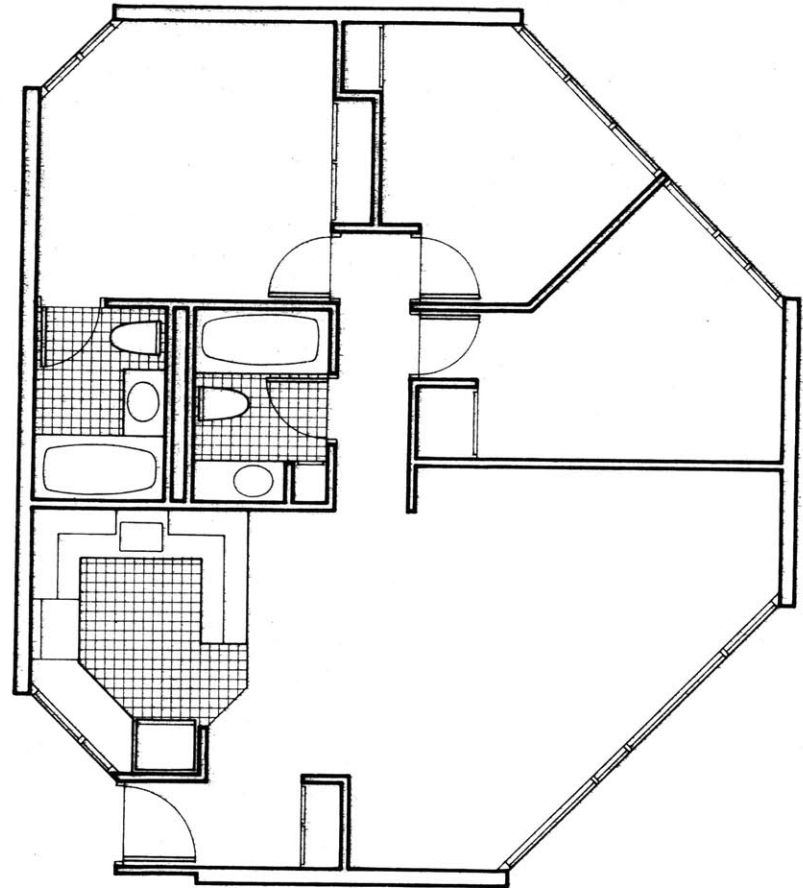

968 SF

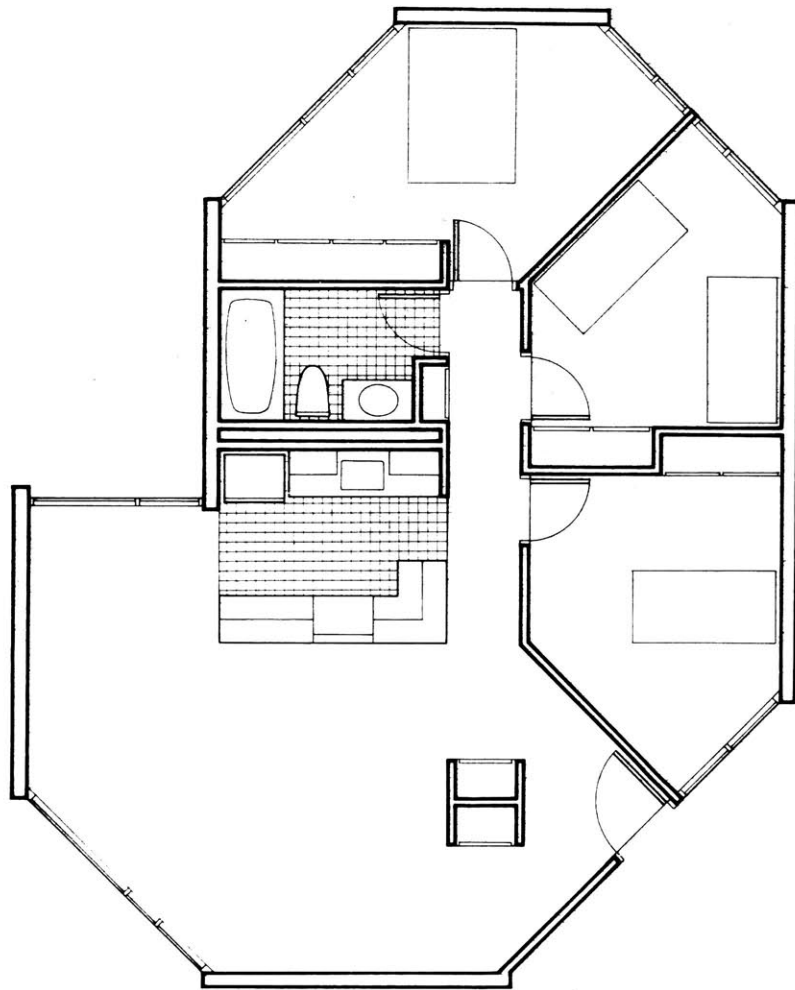

952 SF

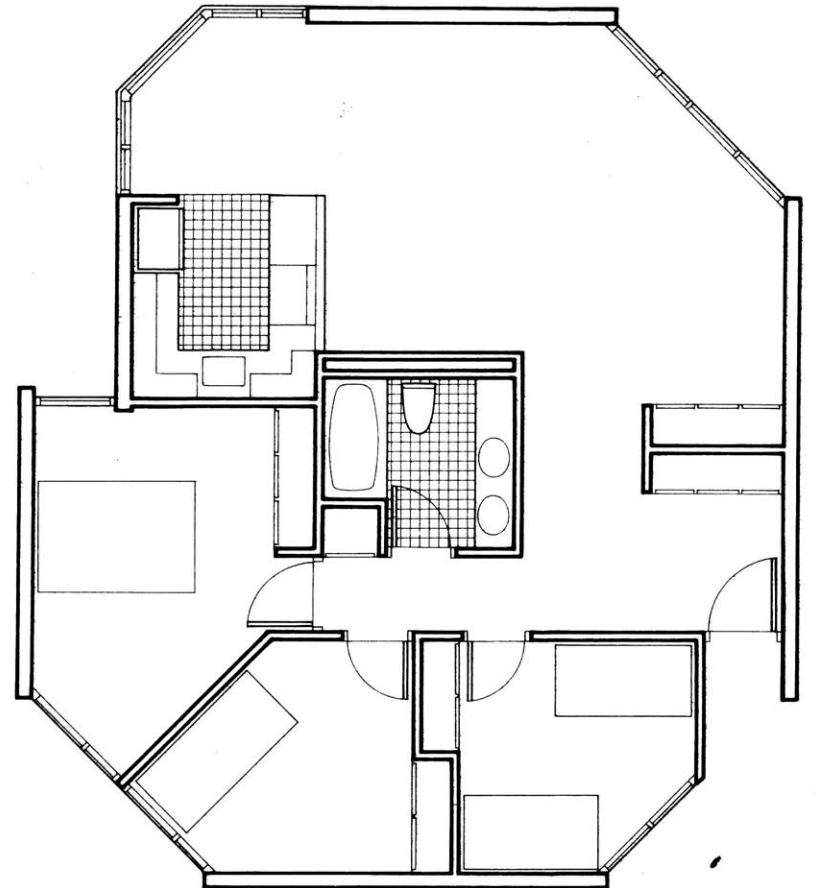

984 SF

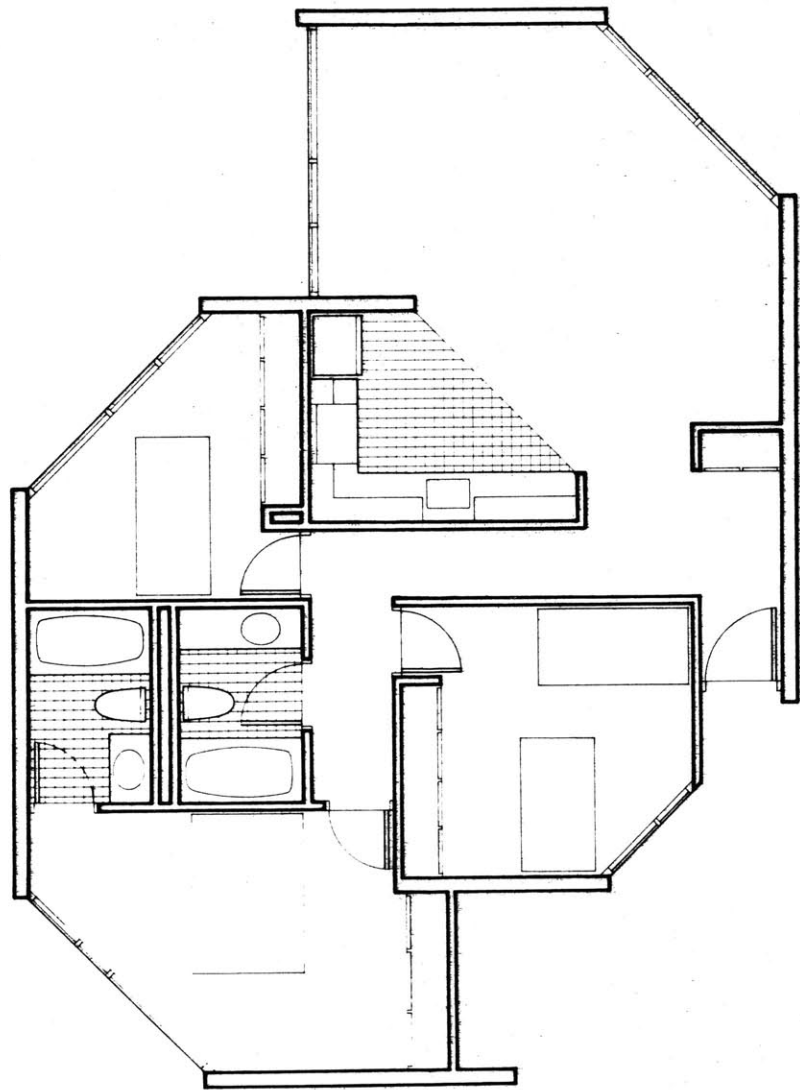

1008 SF

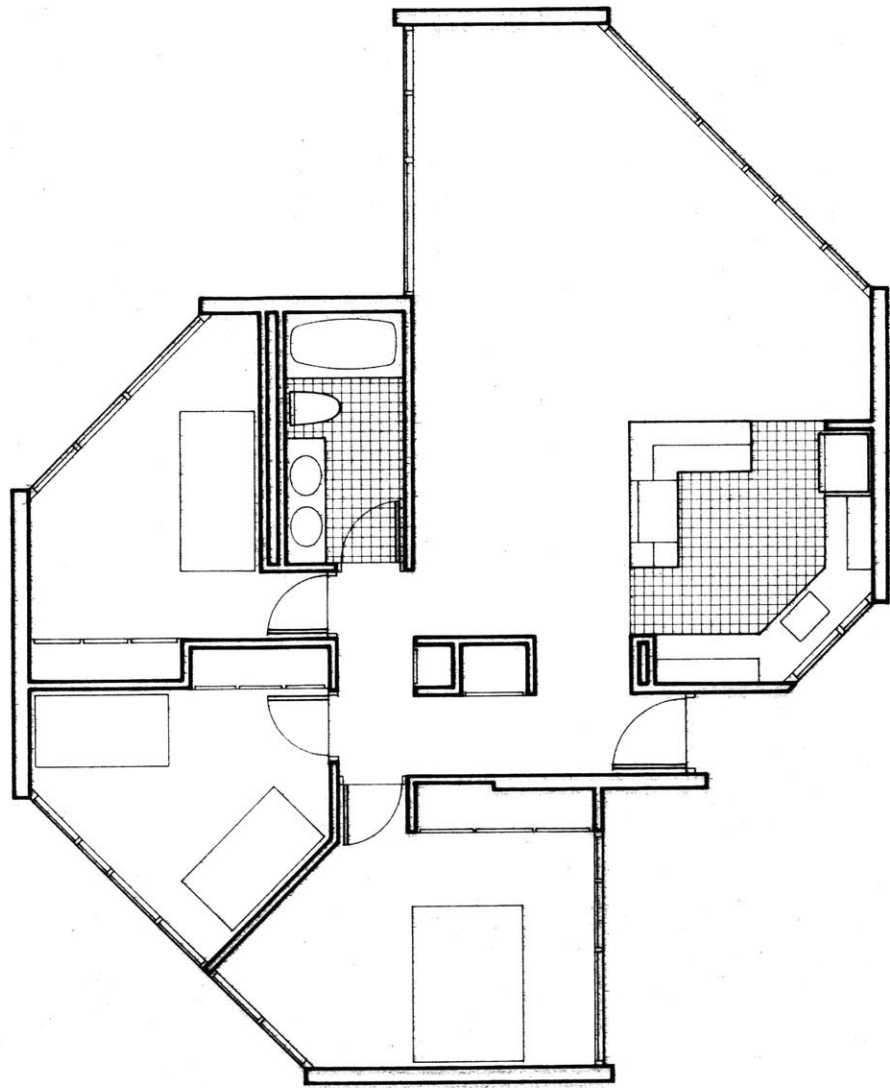

1066 SF

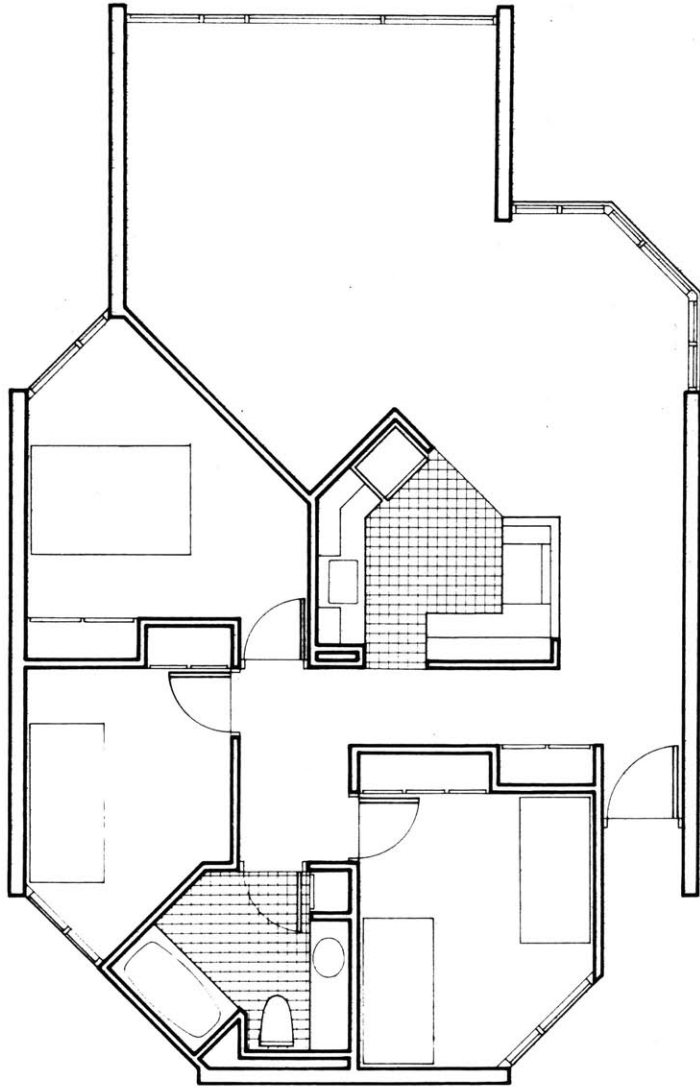

1056 SF

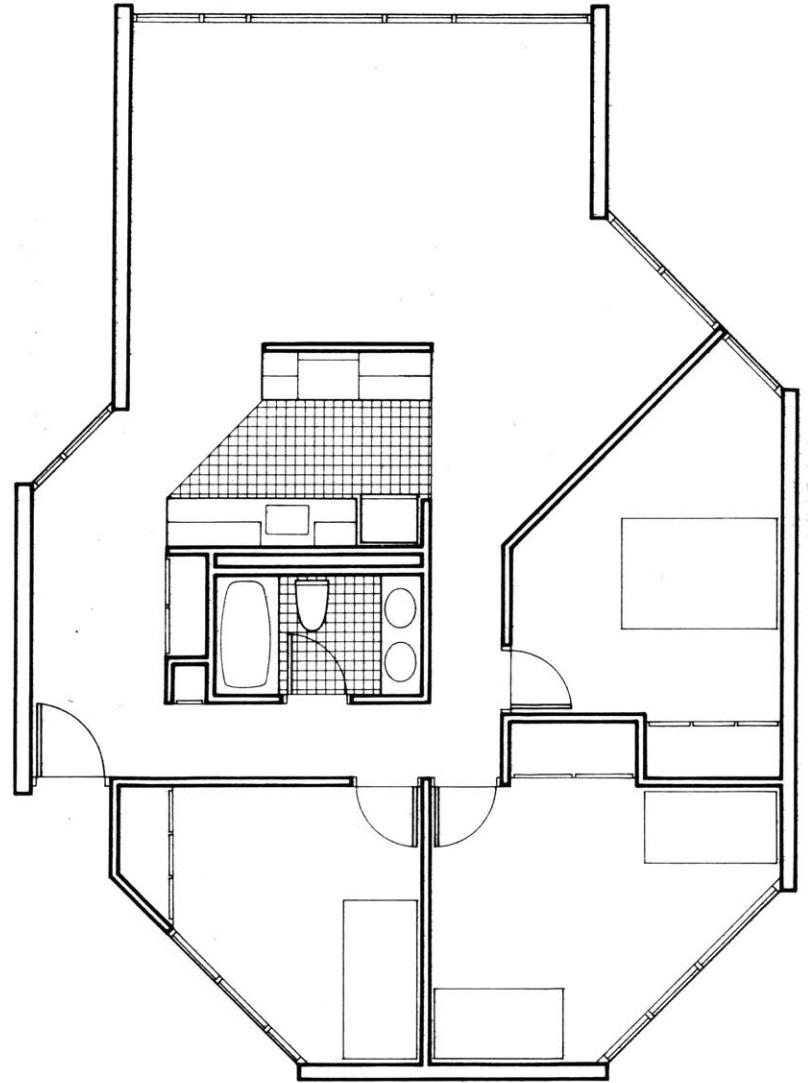

1136 SF

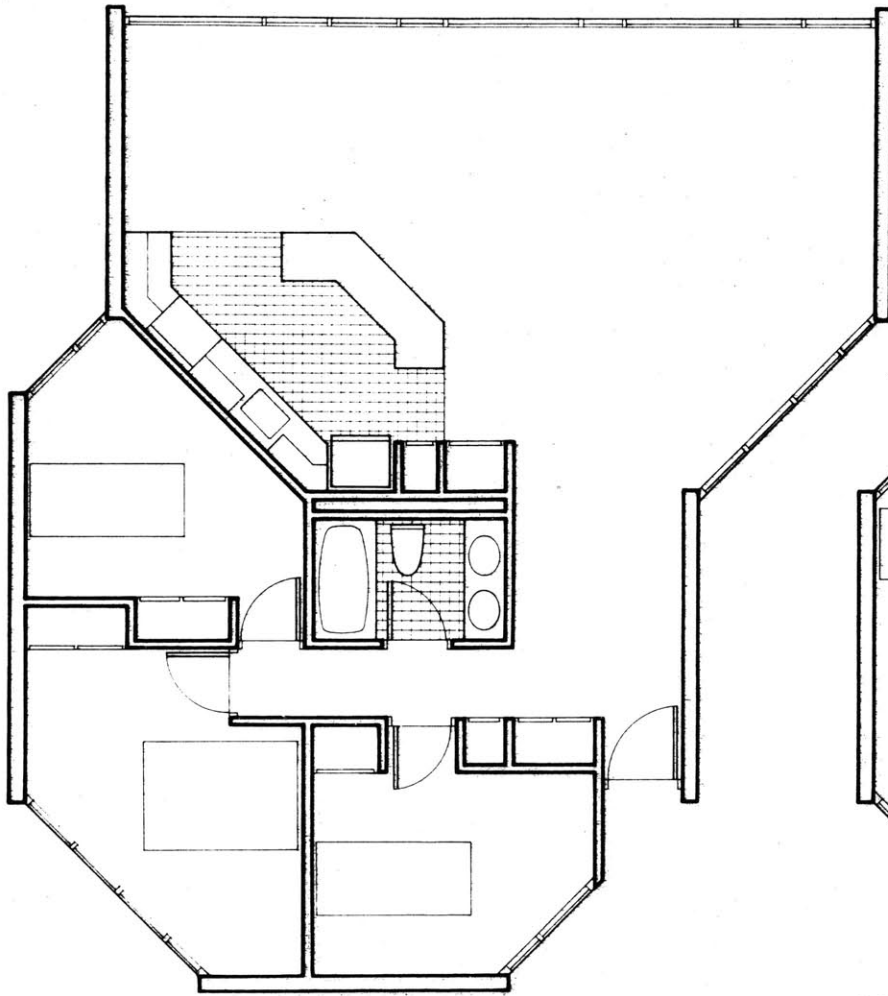

1128 SF

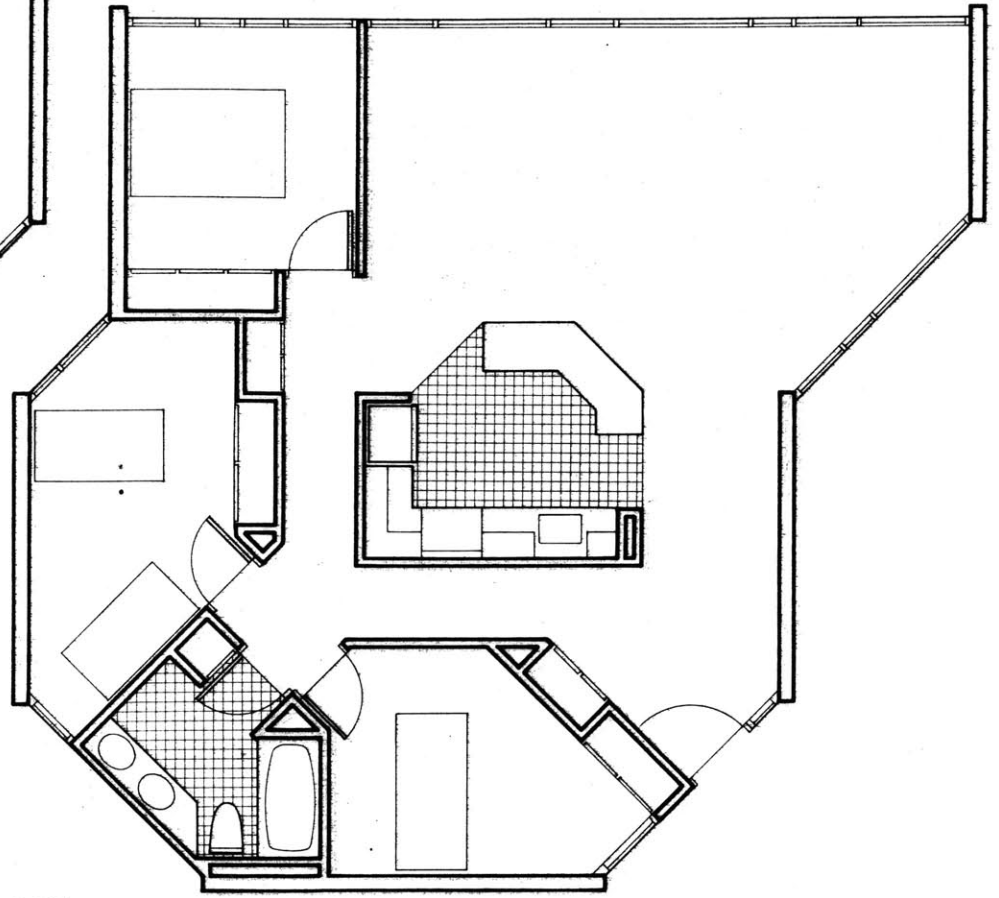

1216 SF

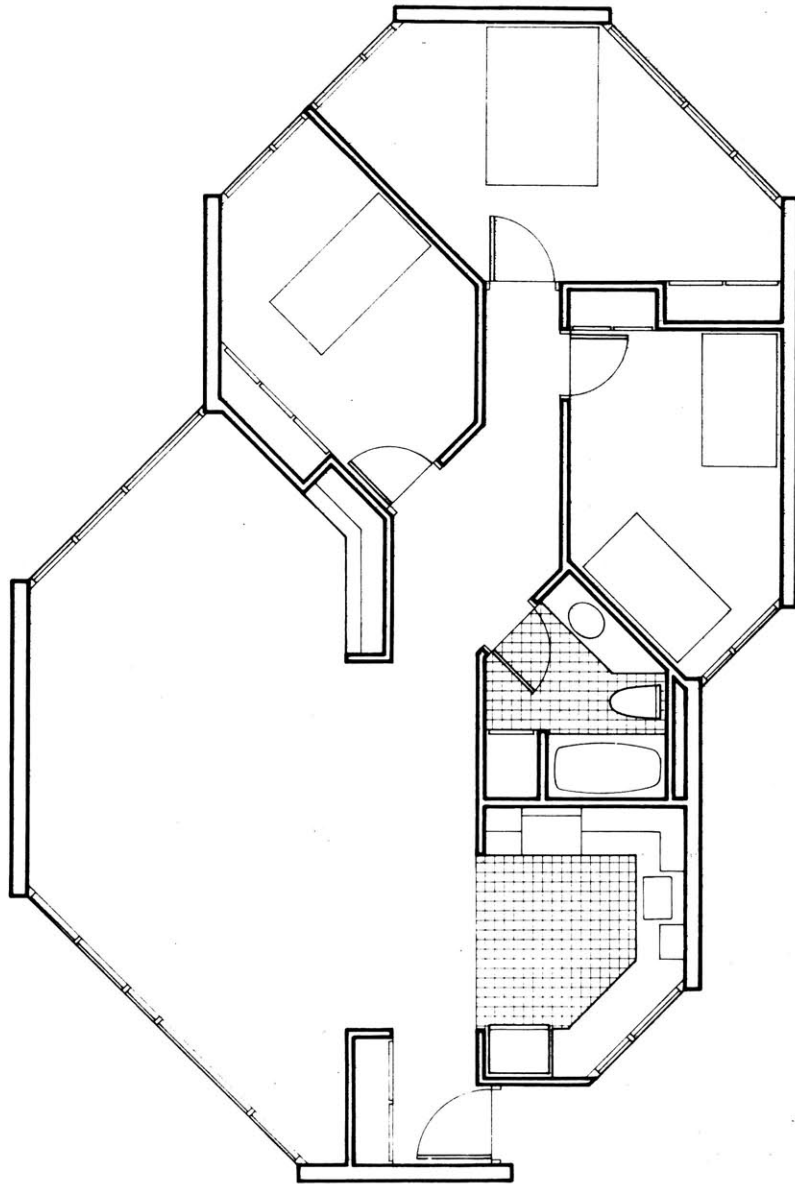

1120 SF

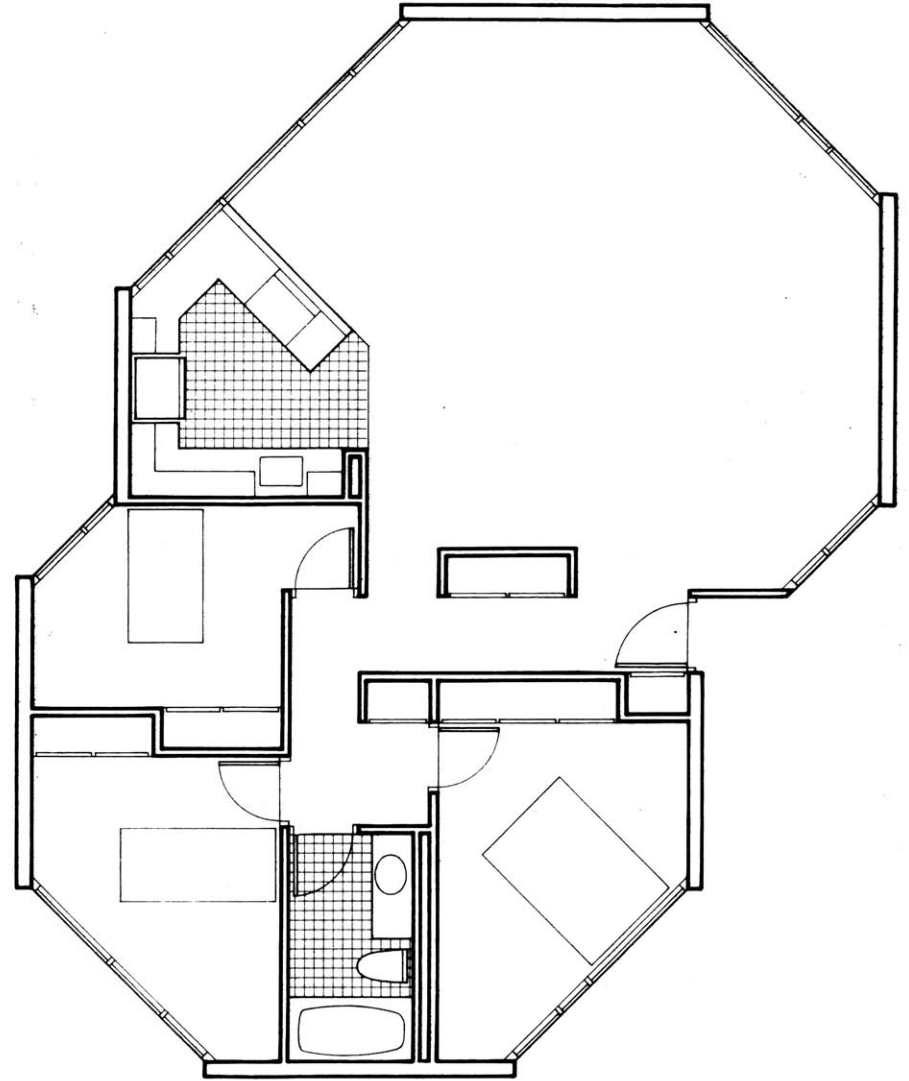

1168 SF

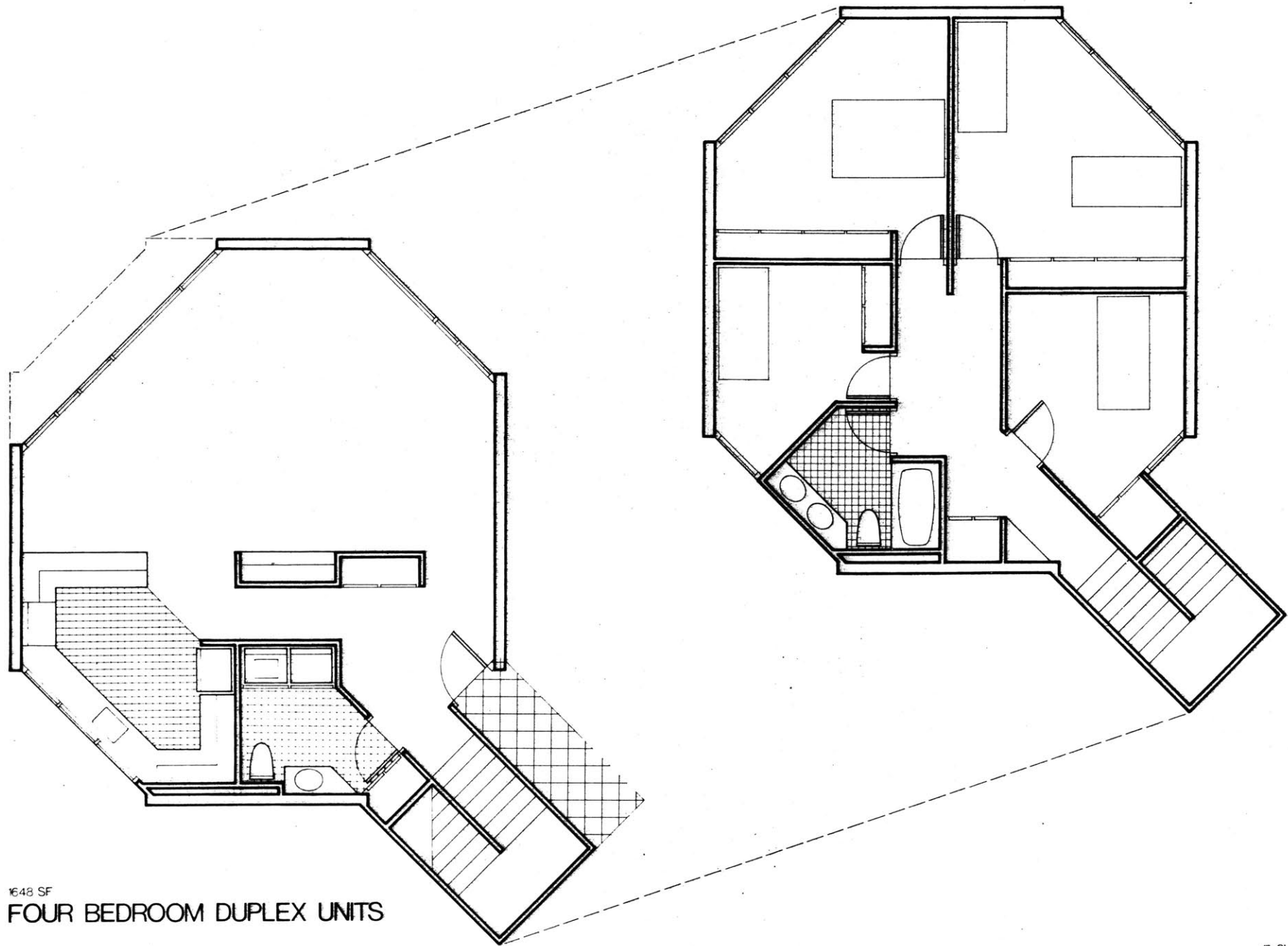

1648 SF
FOUR BEDROOM DUPLEX UNITS

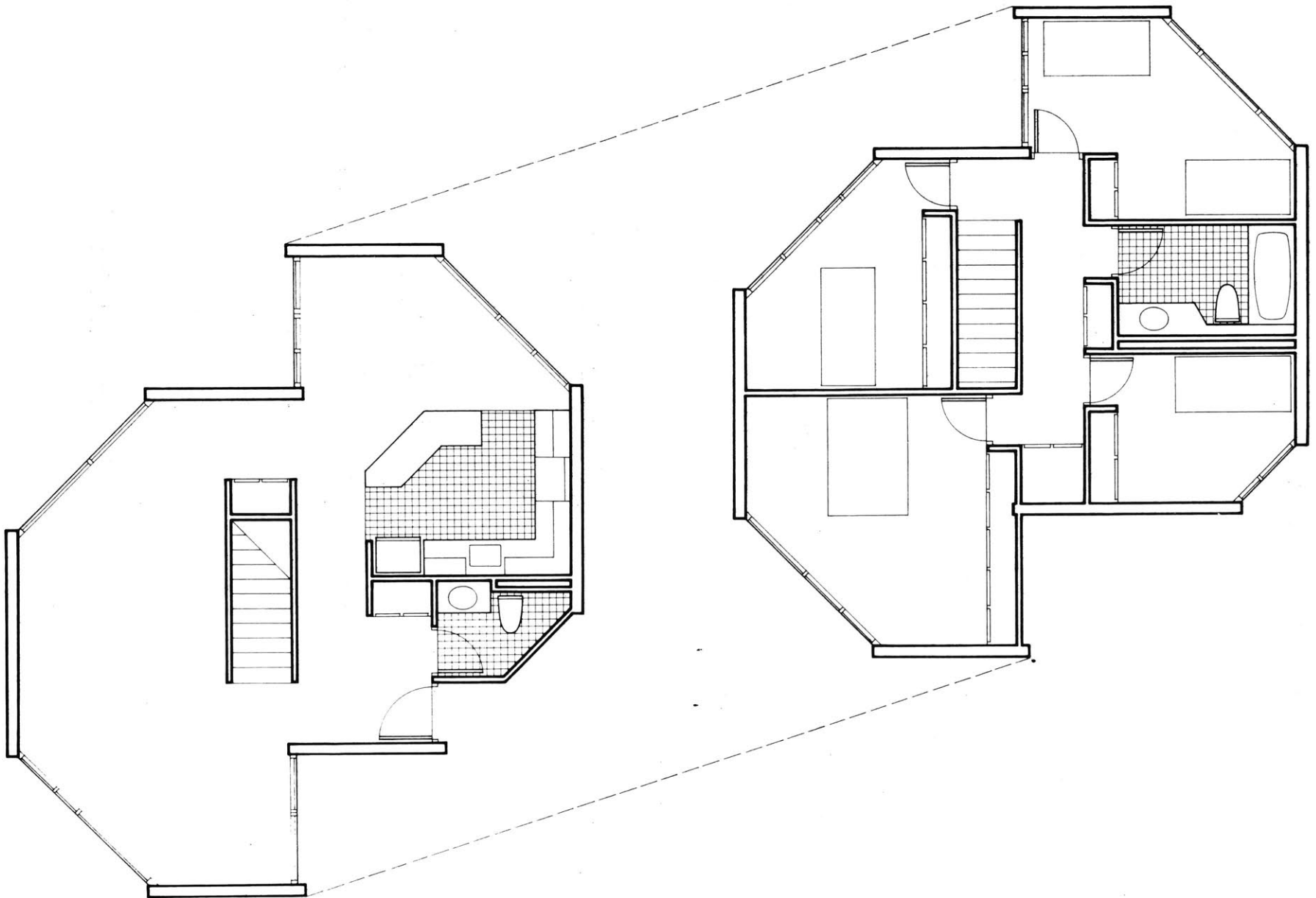

156C SF

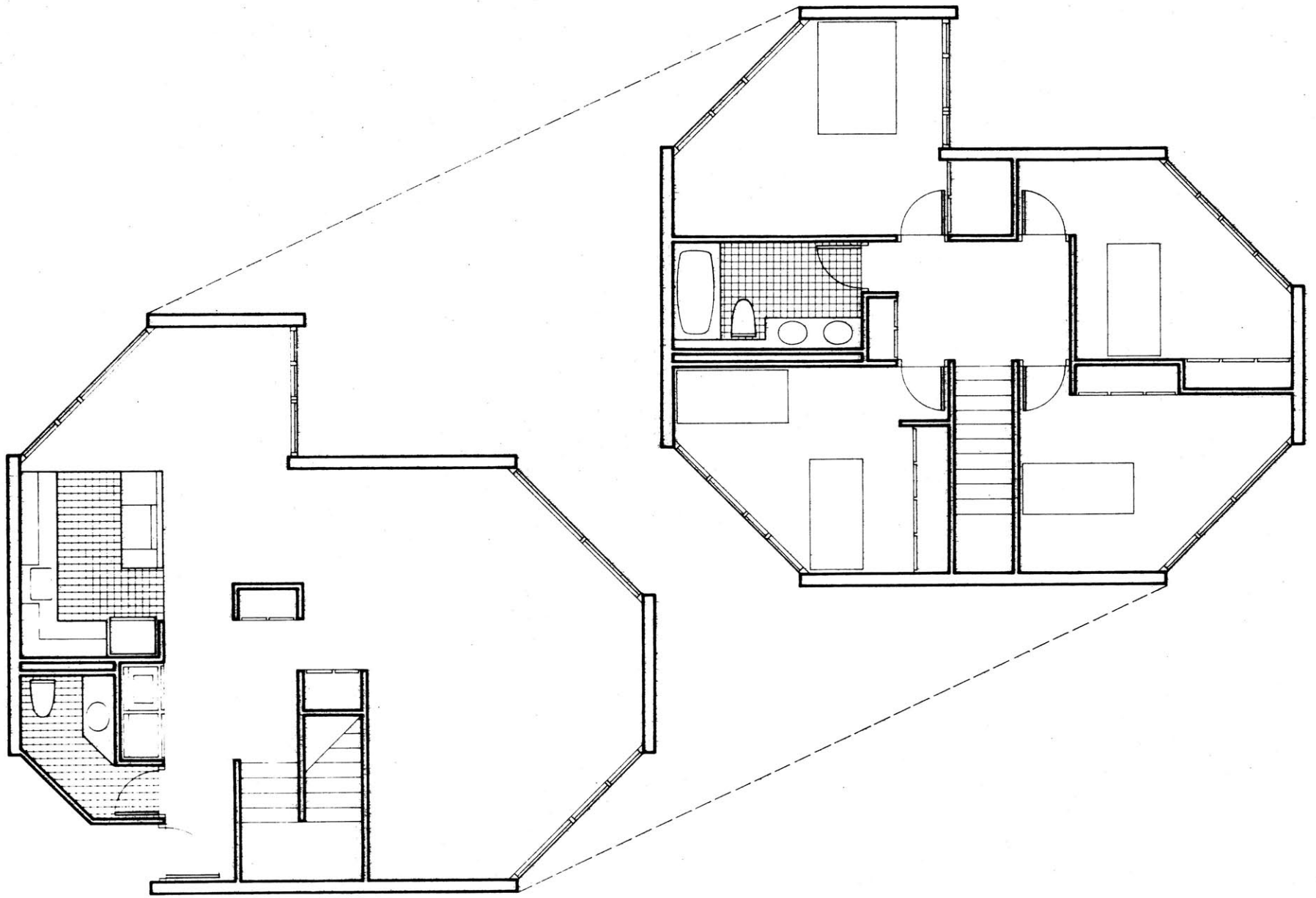

1728 SF

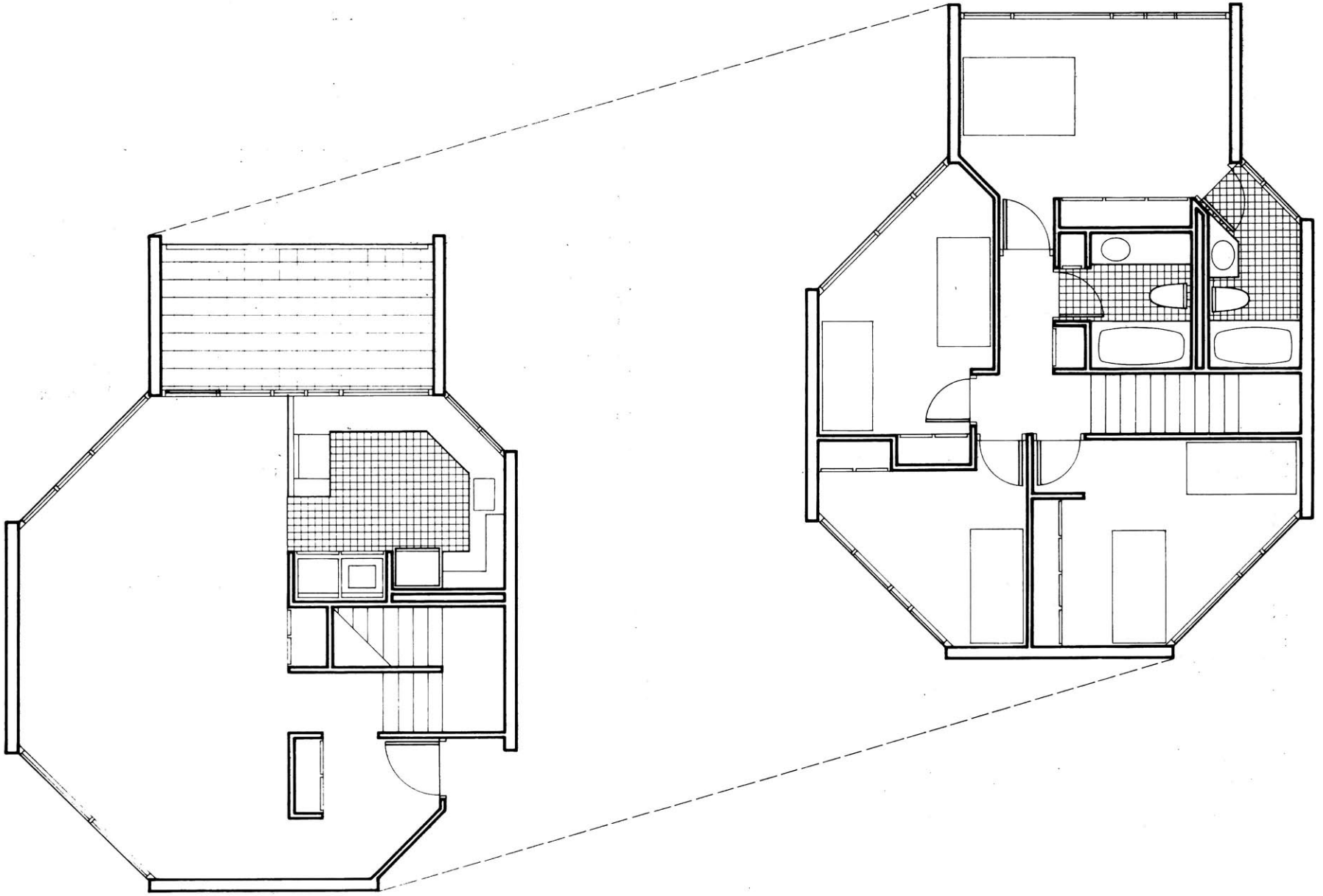

1616 SF

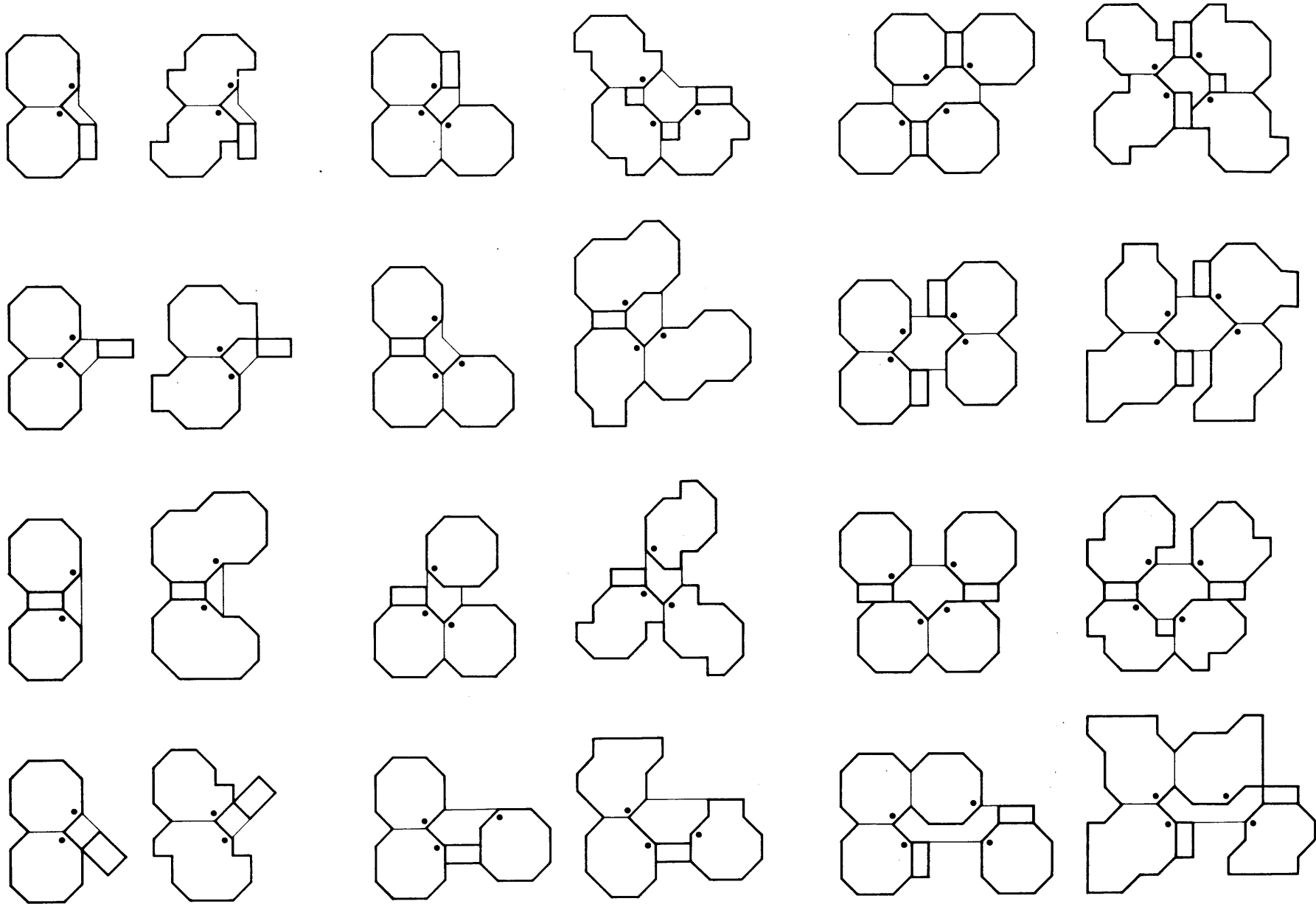

2-4 STORIES

UNIT CLUSTERING

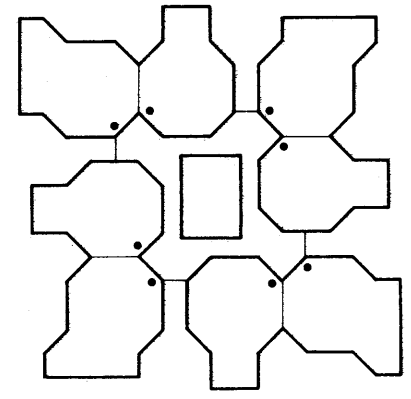
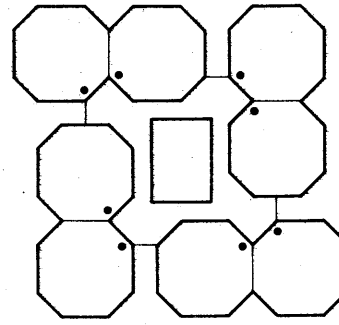
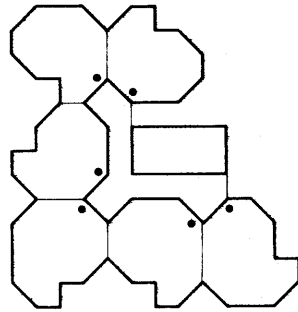
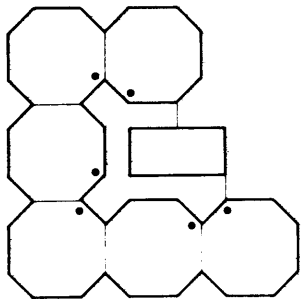
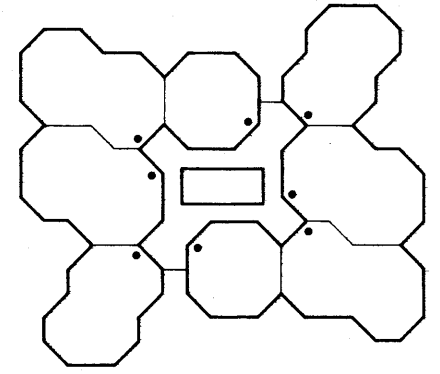
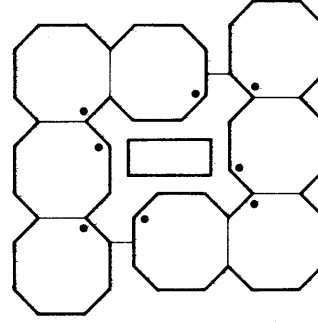
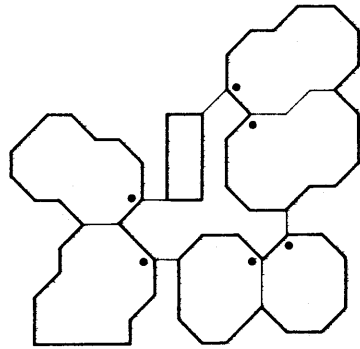
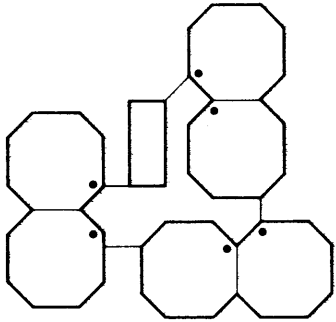
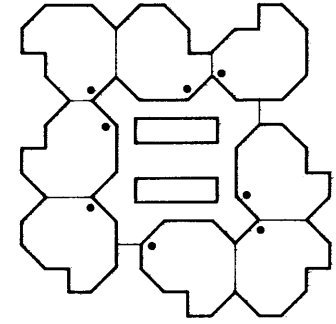
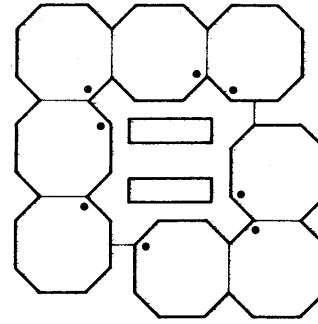
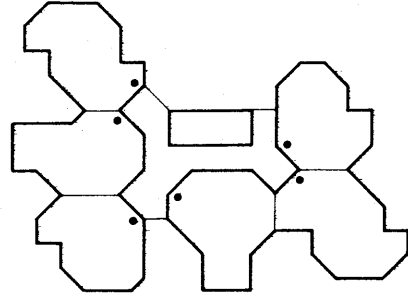
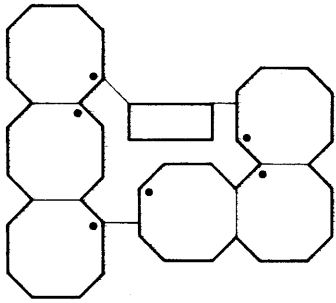

4-8 STORIES

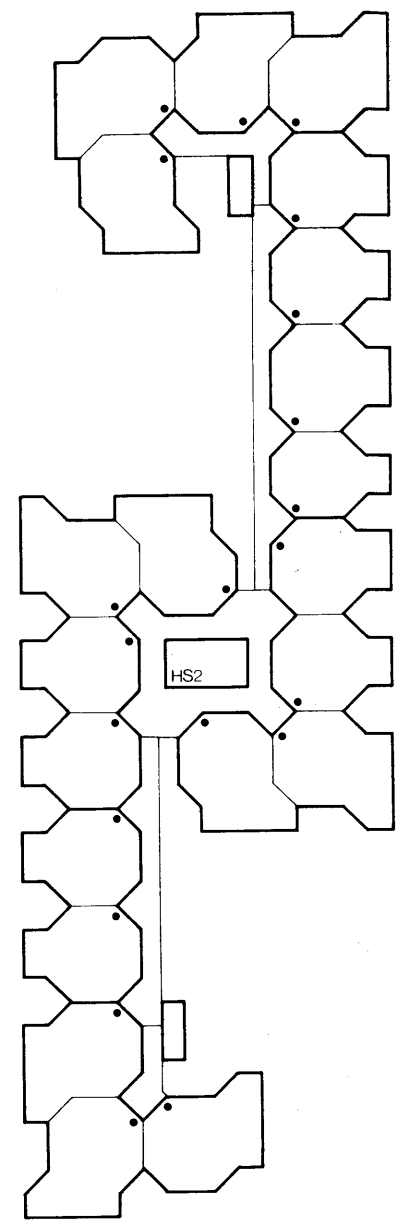
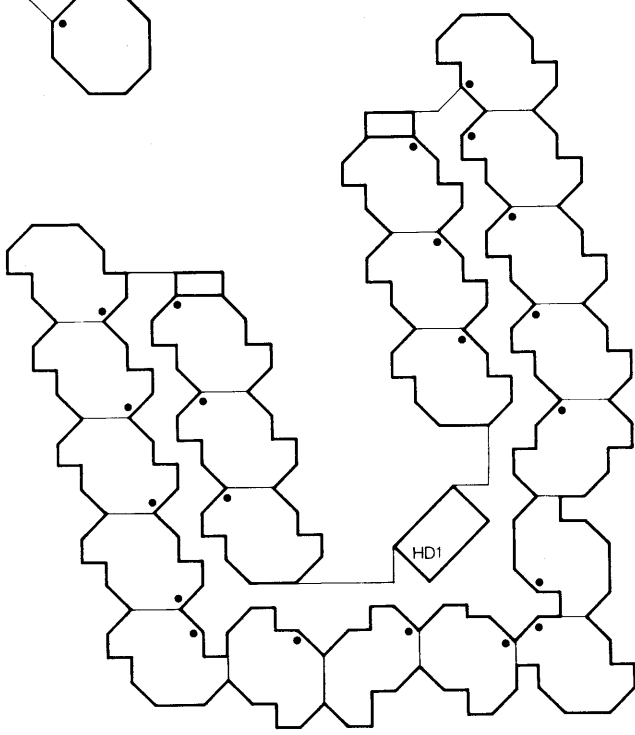
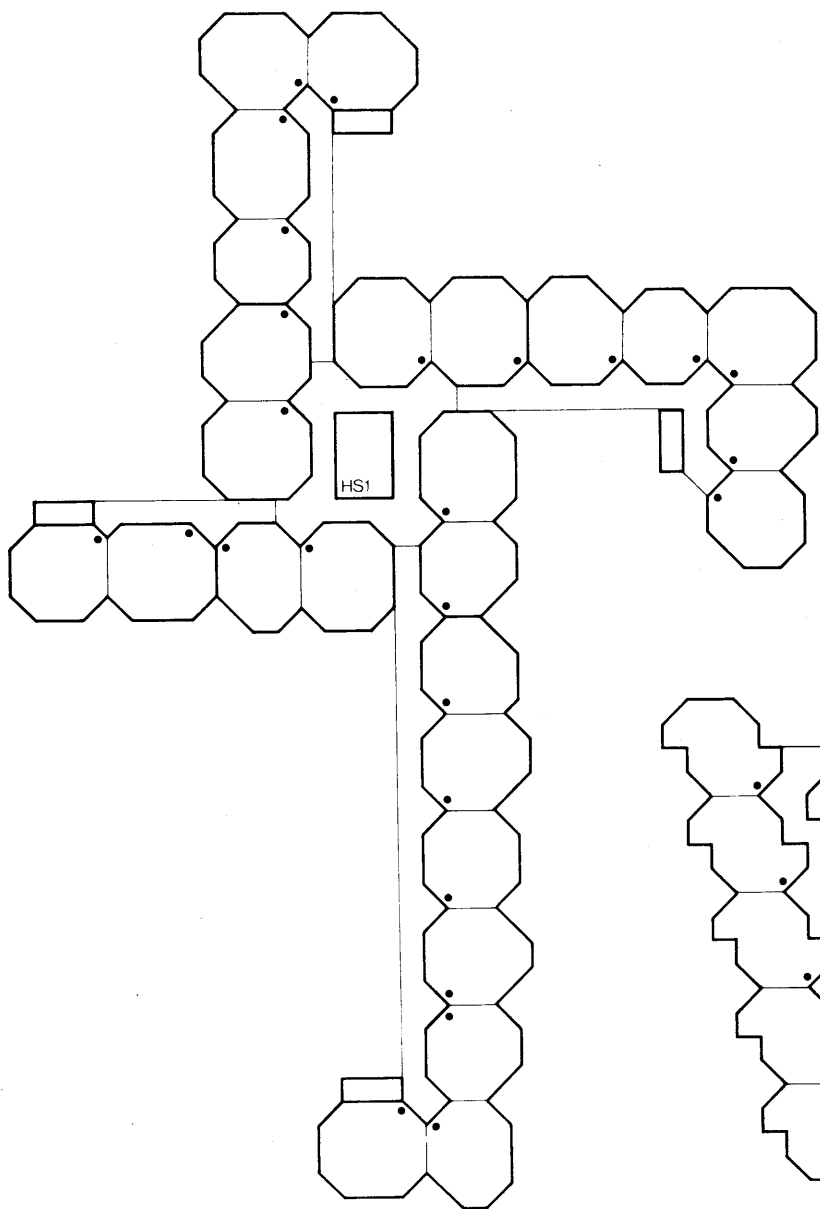

6-12 STORIES

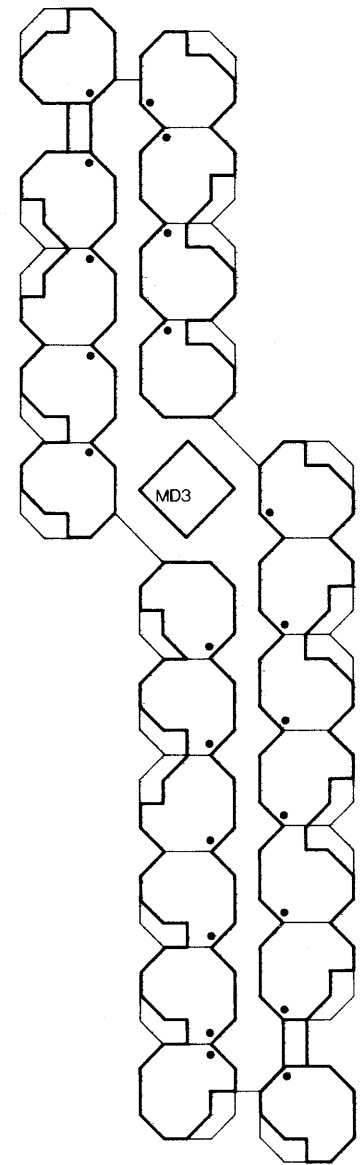
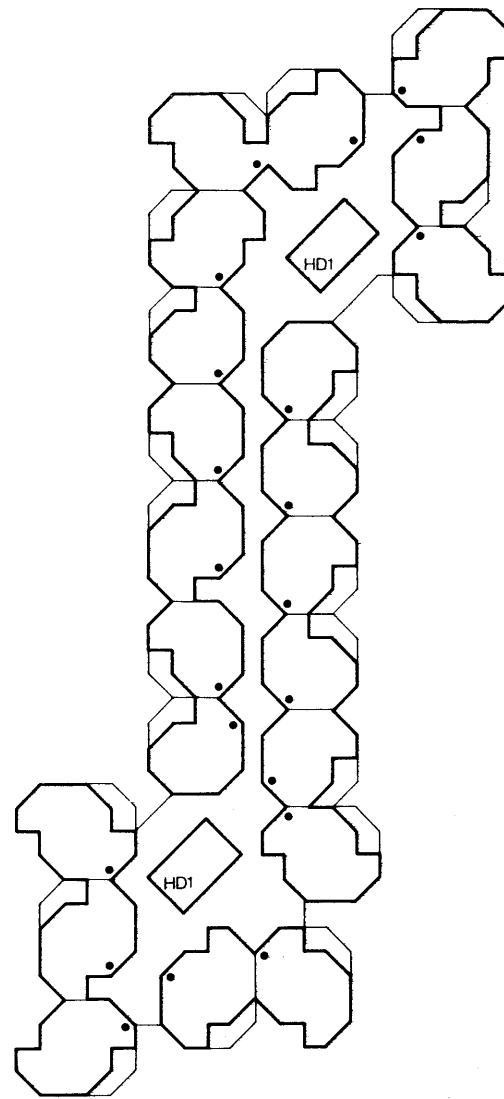
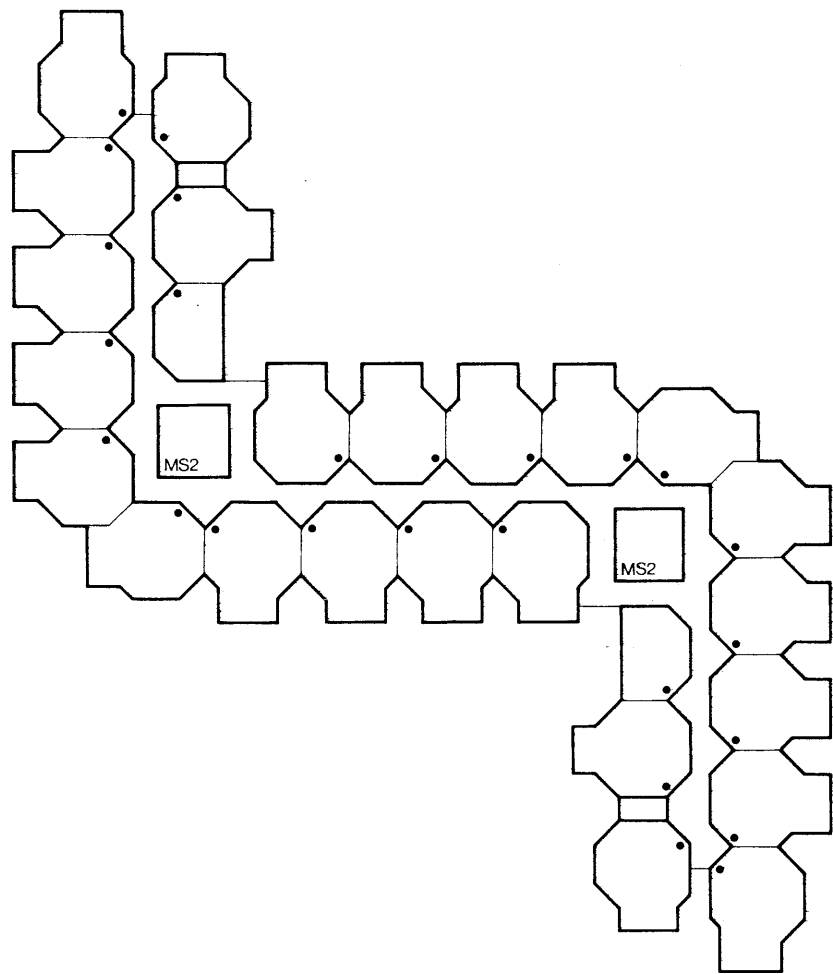

10-20 STORIES

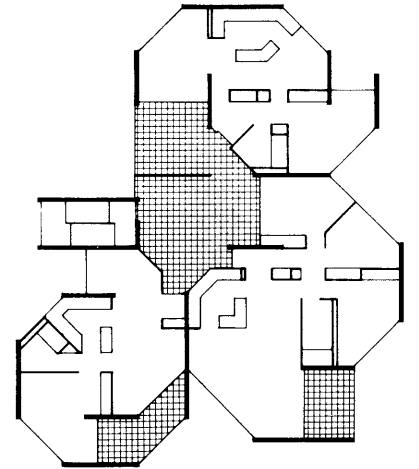
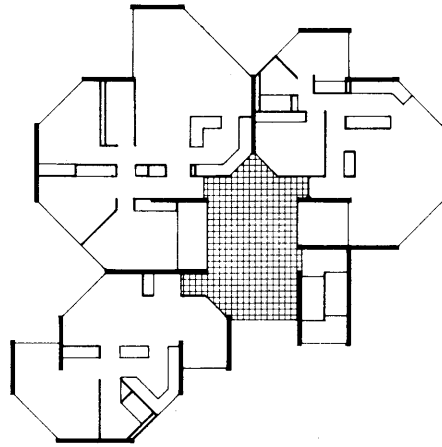
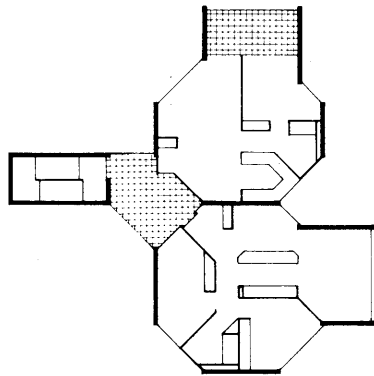
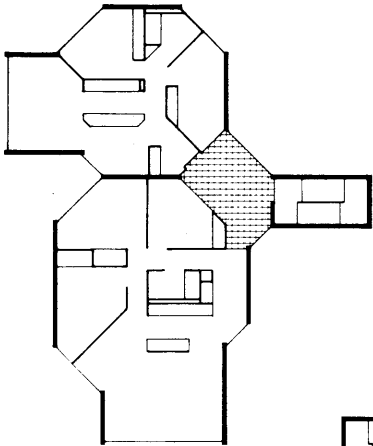
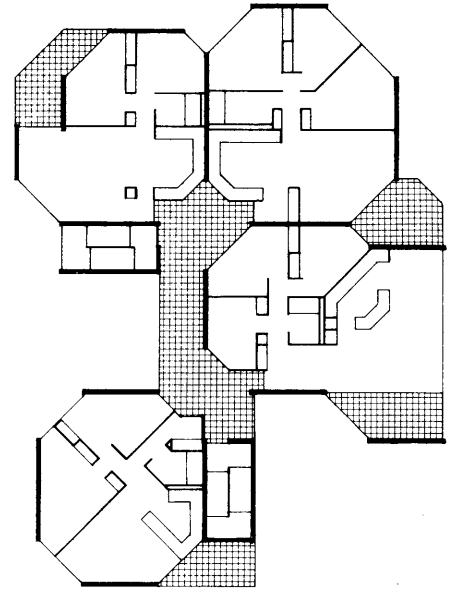
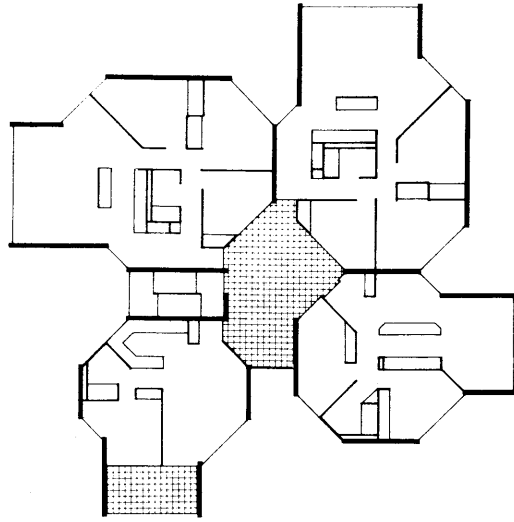
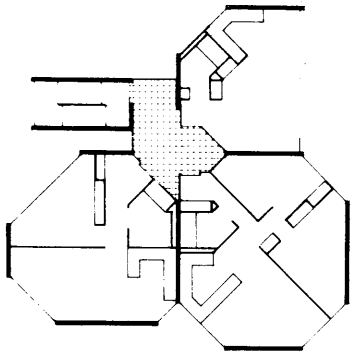

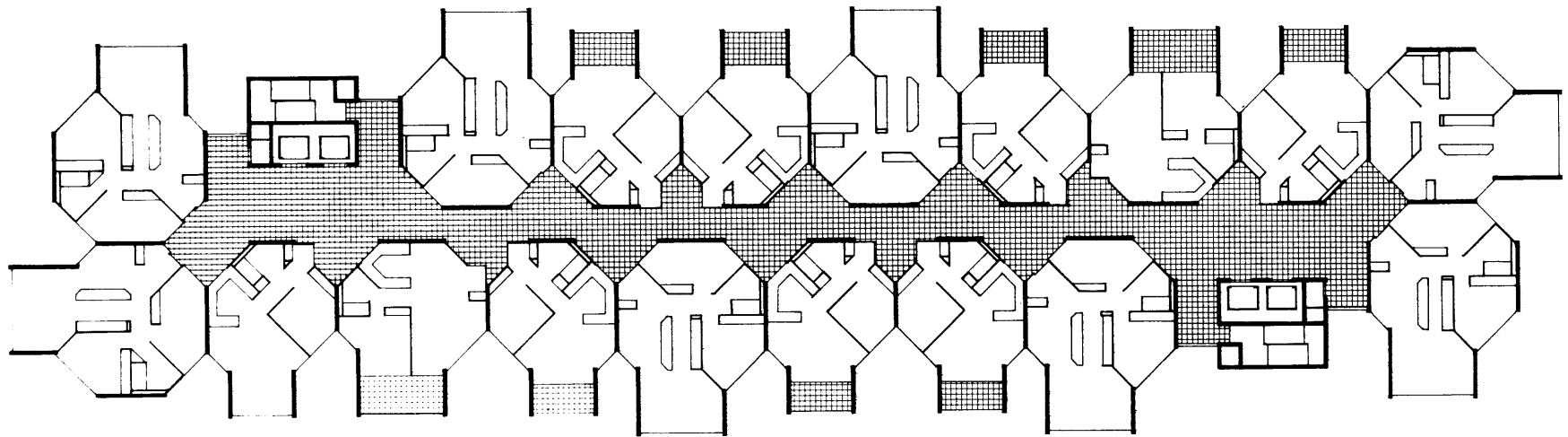
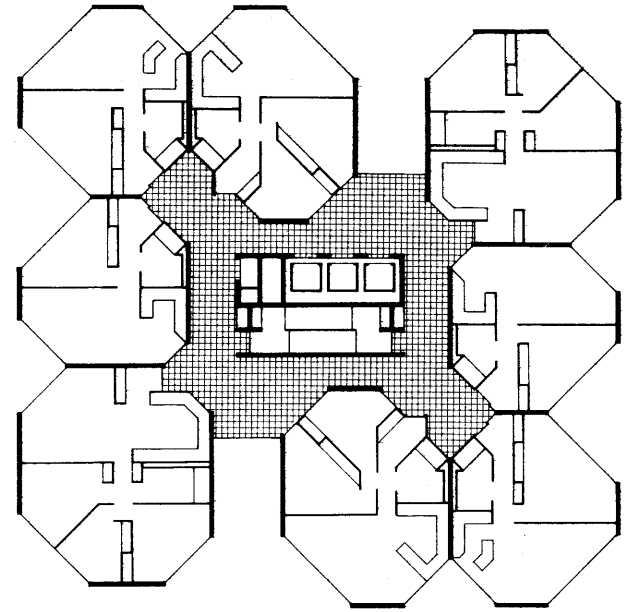
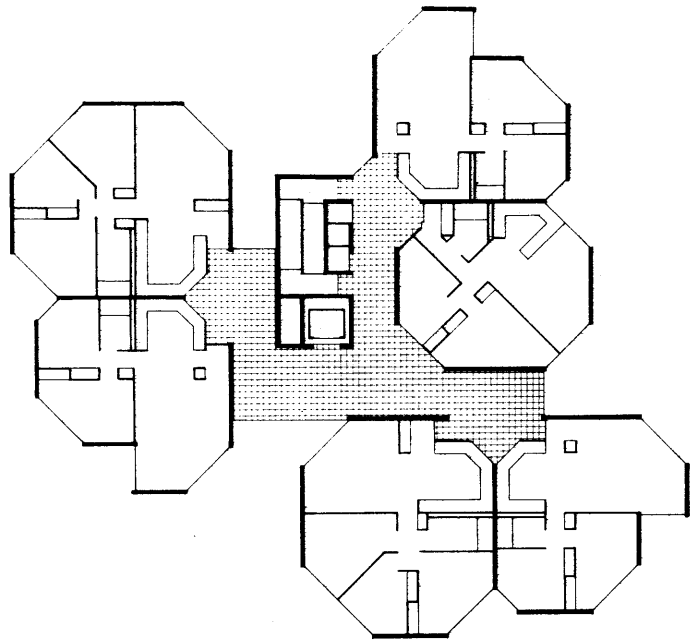

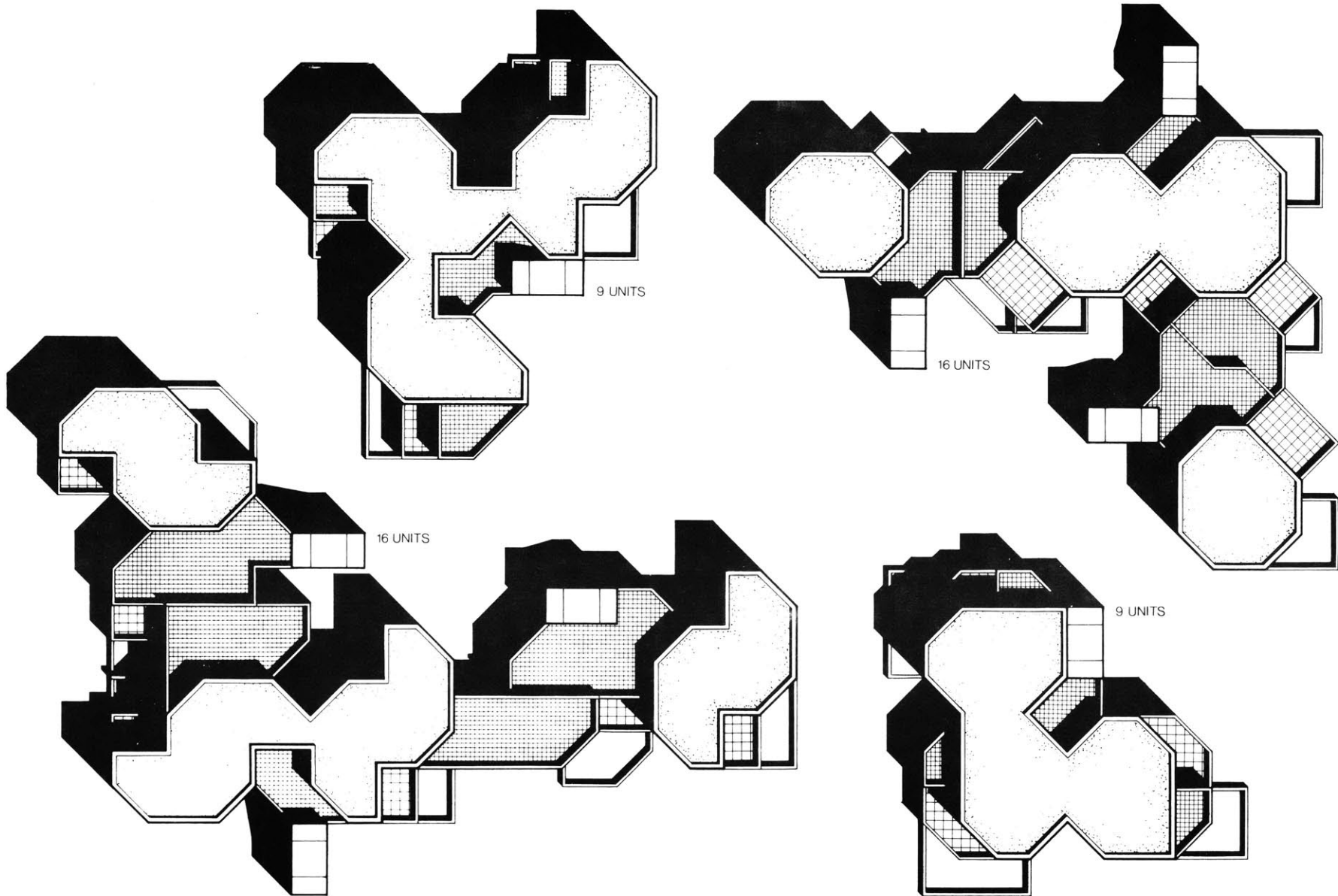

THREE STORY CONFIGURATIONS
BUILDING MORPHOLOGY

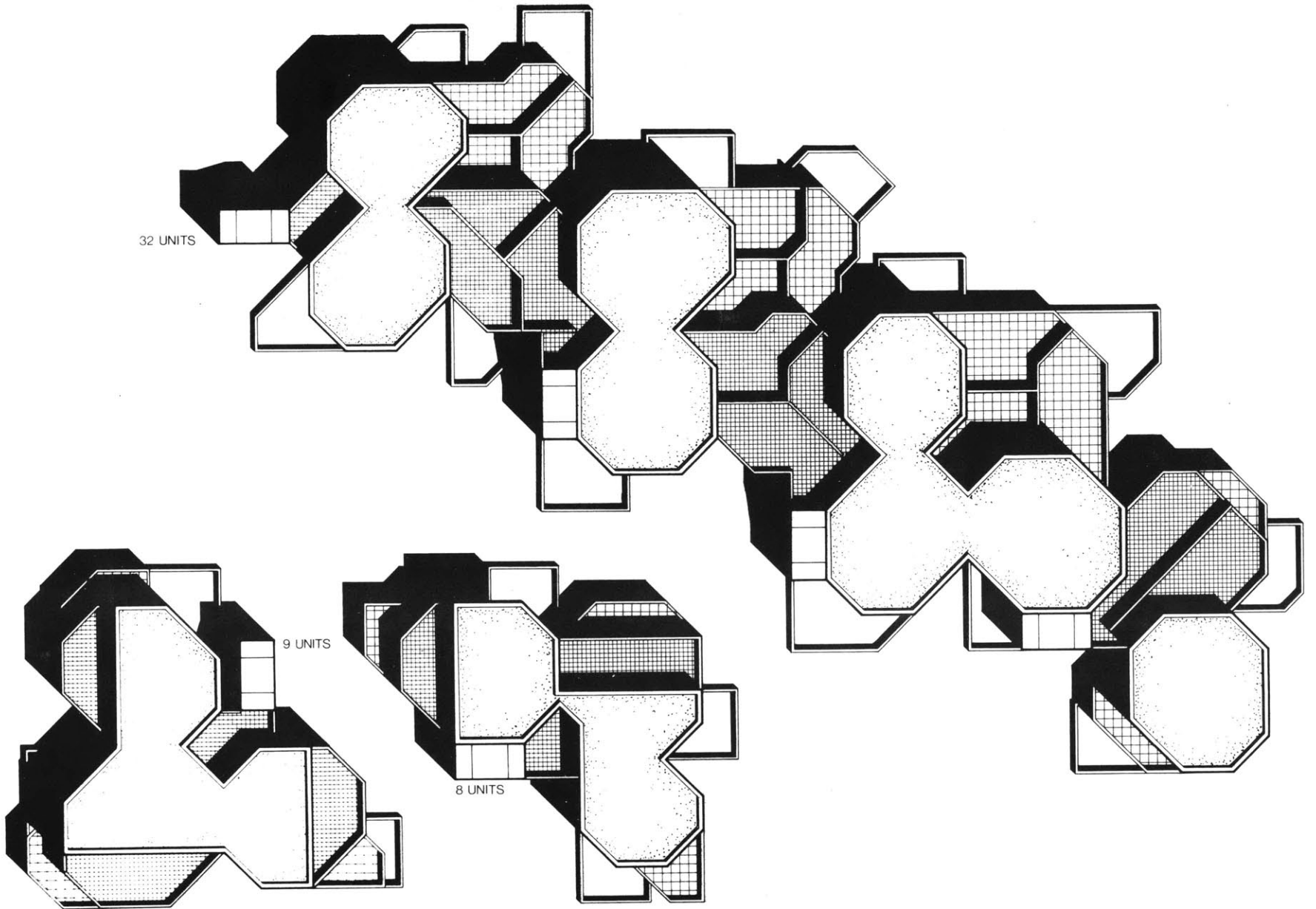

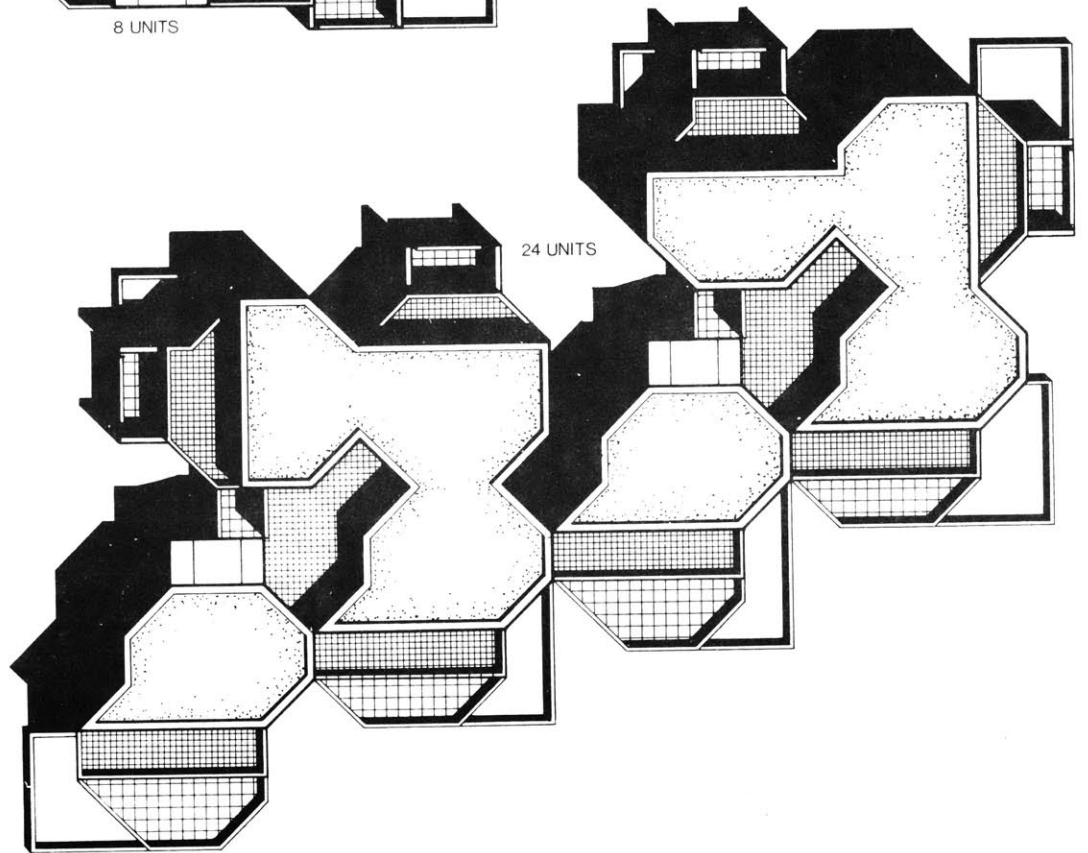
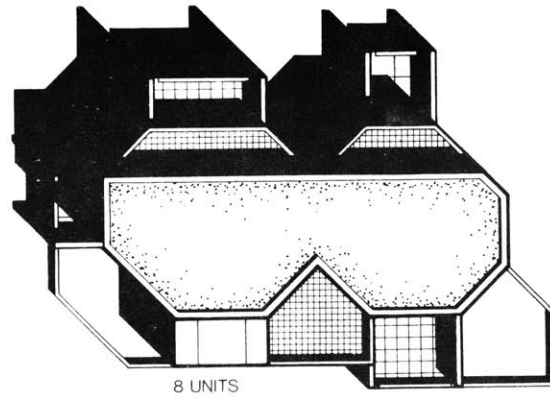
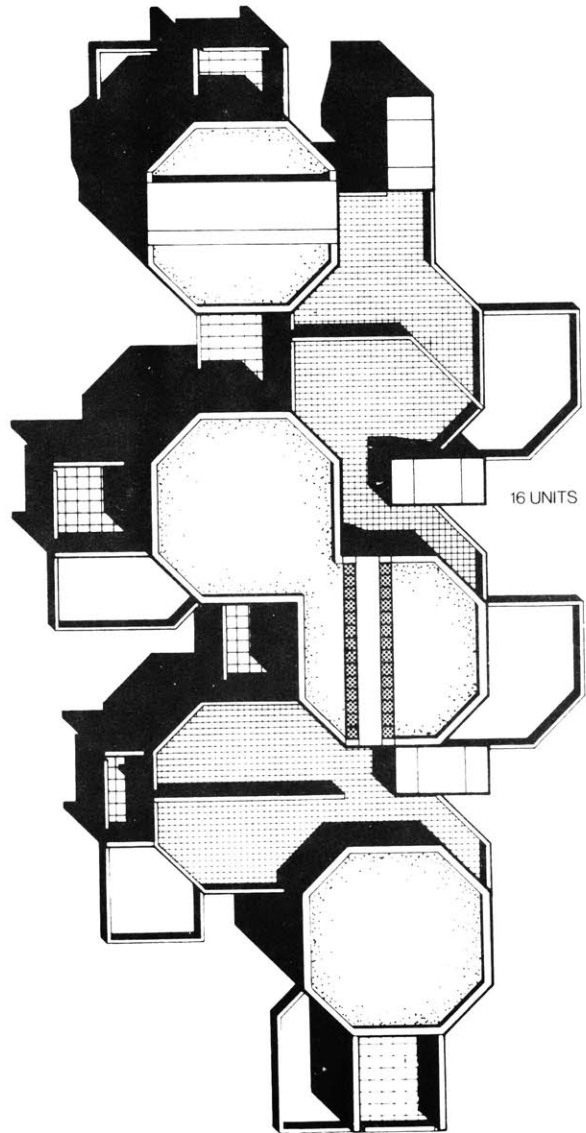

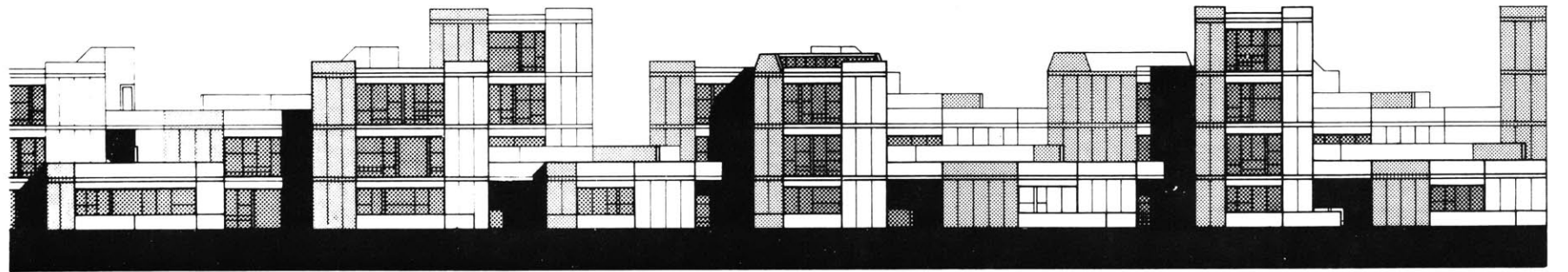
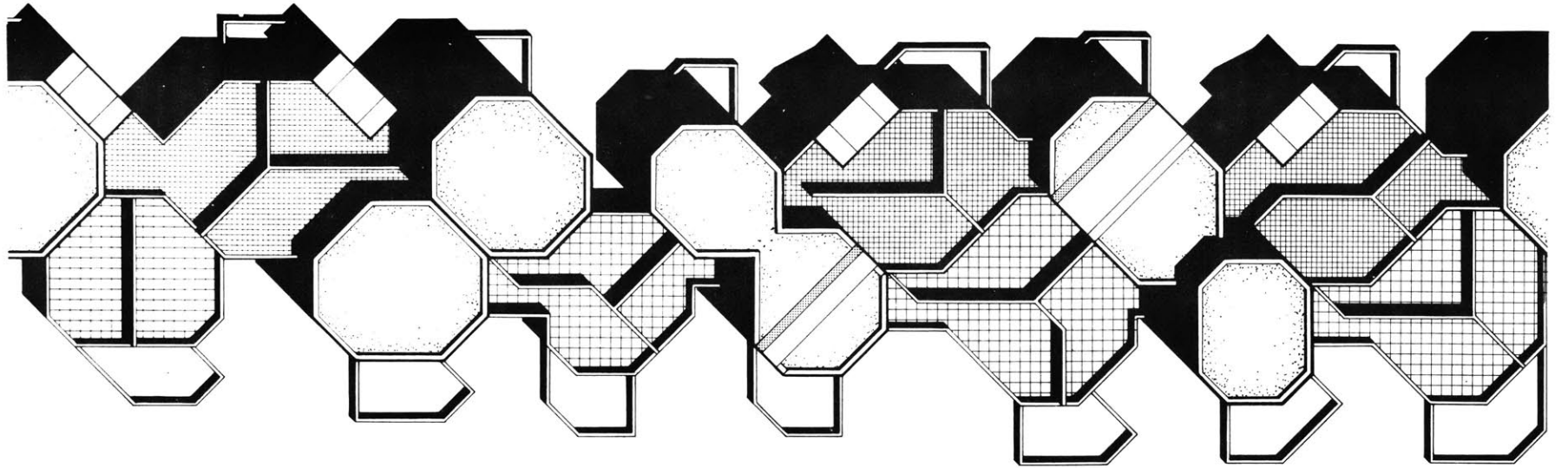

There is a need to apply any building system to a variety of specific site situations. Only in this way can the possibilities and limitations of that system be fully examined and evaluated. Within any city there is a wide range of available situations to which a housing framework may be applied. These potential sites require varying building density, shape and structure.

I have chosen three urban sites of similar size, but of totally different character and surroundings. These sites should allow demonstration of the full range of the system. The solutions presented are not intended as earnest proposals for each specific site. The individual sites provide a hypothetical model made up of restrictions and opportunities by which the application of the system is ordered.

The first site is composed of cleared portions of two residential/warehouse blocks. Large segments of the blocks are still occupied so the new housing would be providing infill structure to aid in firming up a disintegrating neighborhood. The site contains two large warehouse buildings to the northeast and many small houses to the south. There is a neighborhood super market within one-half block from the site. A large housing complex is across the street to the south. Parking would be handled on existing streets and on the site.

The second site is located on a river, in an urban suburb. The site faces the river to the east, but is separated by a four lane primary roadway. To the north is a married students housing complex for a private university. An old established neighborhood of single and double family houses borders the site to the east, and a factory to the south. The site is one mile from available commercial facilities, which requires a certain amount of these to be contained within the development. Parking must be provided on the site. New structures should be no more than 80'-0 high.

The third site is a wharf within the harbor of a major city. The wharf is vacant and is a prime location for housing. It is within a ten minute walk from the central business, commercial and entertainment core of the city. On the next wharf to the north there are already two 24-story apartment towers. To the south are a number of active warehouse and dock facilities. An elevated central highway passes 100' to the west, creating a barrier between the harbor front and the city core. The ocean provides great views and openness to the east. There is a shortage of other open land around the city core so this particular site would be expensive to obtain, requiring a high density living situation to maximize use of the site. Parking facilities are provided by large city parking structures within easy walking distance.

SITE APPLICATIONS

*

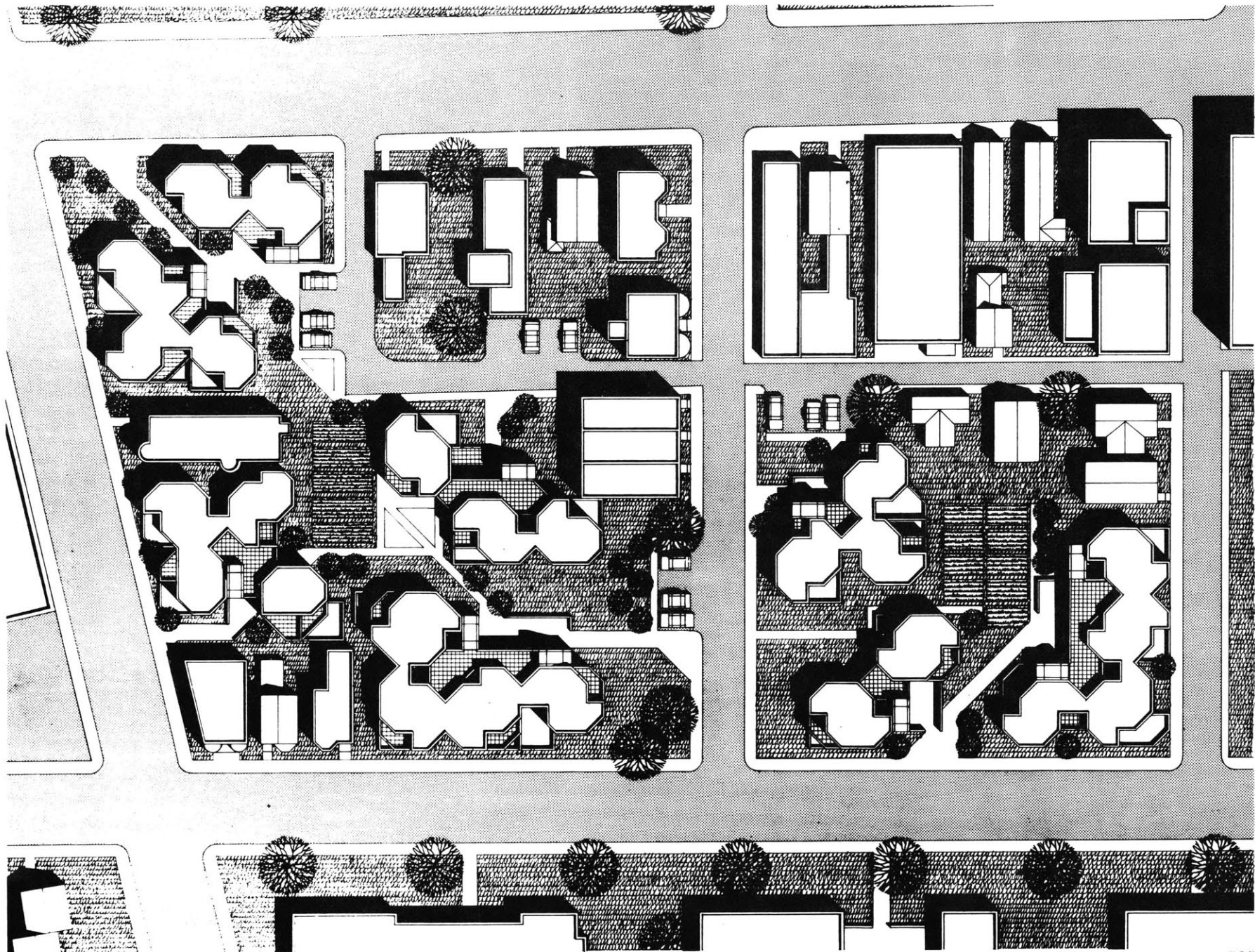

75 UNITS

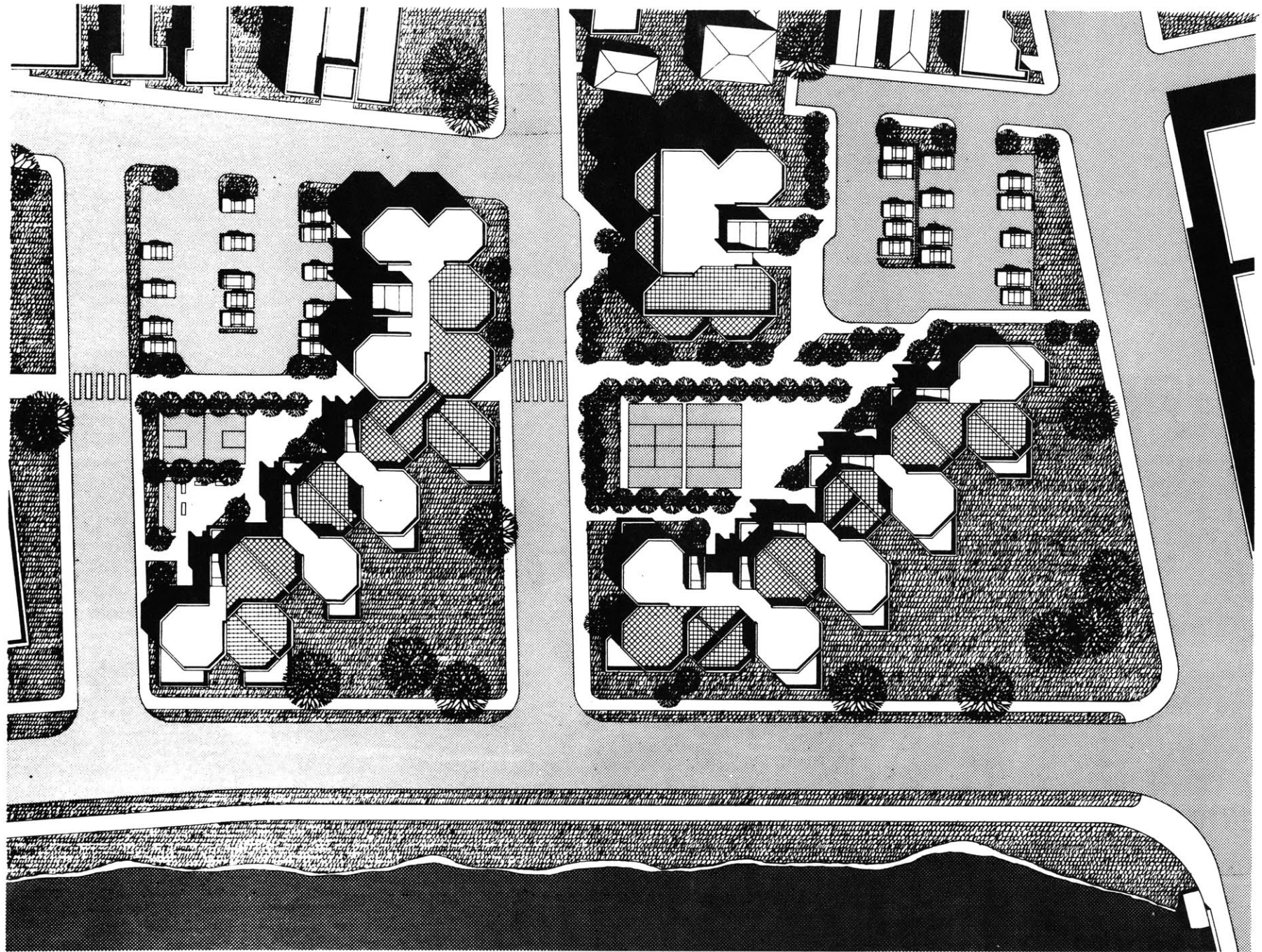

106 UNITS

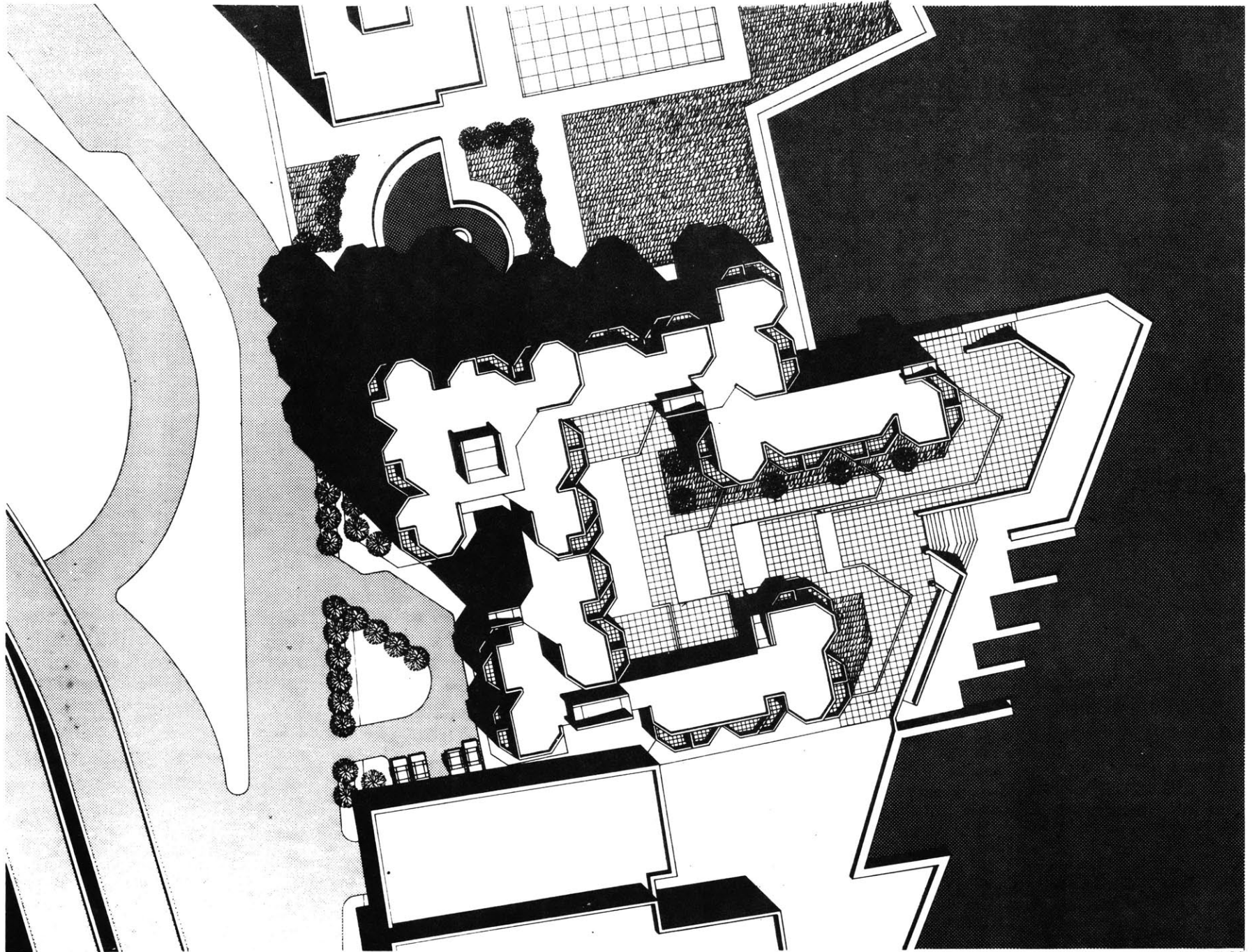

240 UNITS

There is a need to make critical comments on this study. And it is more important to discuss the weaknesses and the limitations of the system than to restate its strengths and potentials. There are a number of shortcomings inherent in the system which create limitations in its application. However, I do not think the imperfections in the system should eliminate it from consideration.

The first weakness proved to be the basic inflexibility of the load-bearing walls. Although units on upper floors can be varied by cantilevering of bearing walls, the walls must remain on the same grid location. The implications of this are that unit types must remain the same as the first on all succeeding floors. One bedroom must stack vertically on one bedroom. If the lower units are two, three and four bedroom types, the stacking floor areas may decrease producing a smaller unit type.

The second limitation within the system has to do with the diagonal openings between bearing walls. Each unit contains at least four of these openings in the structure, and each opening is oriented in a different direction. Because one of the openings is required for the entrance, three openings remain for windows. The three remaining openings require a certain distance from

neighboring windows to insure privacy. This requirement makes it difficult to achieve high densities while maintaining adequacy of view and privacy. In formulating a specific design, great attention must be paid to orientation of openings in creating clusters of units. It should be noted also that some of the shapes, notably the split octagon, have greater potential to generate an interlocking, overlapping geometry. This ability can enhance cluster formation and give greater privacy to openings and unit outdoor spaces.

There also seems to be a problem in unit interior planning, relating to some of the basic structural shapes. In shapes forming circular or extended circular volumes, as the octagon or extended octagon, the entrance is on the perimeter. Thus, the entrance is far from the centroid of the unit, promoting linear circulation within the units. In shapes of divided volume, as the split octagon, the entrance may be located closer to the center of the unit. This allows a nodal, centralized circulation pattern. The rooms and spaces are located on the perimeter with circulation minimized in the center. This is not a peculiar problem related only to this system as it can occur in most units that enter off a common lobby or corridor.

CONCLUSIONS

1. Alexander, Christopher, "Major Changes in Environmental Form Required by Social and Psychological Demands," Japan Center for Area Development Research, J.C.A.D.R., Tokyo, Japan, 1969.
2. Catalano, Eduardo, "Housing Design Guidelines," Systems and Industrialization Studio, Massachusetts Institute of Technology, 1976.
3. Cornell University, "The New Building Block," Cornell Press, Ithaca, New York, 1969.
4. Government of Iran, Habitat Bill of Rights, National Committee of Human Settlements, The Ministry of Housing and Urban Development, Tehran, Iran, 1976.
5. Jacobs, Jane, The Death and Life of Great American Cities, Vintage Books, New York, New York, 1961.
6. Kell, Duane A. and Craig E. Rafferty, "A Housing System: A Study Based On the Production Capabilities of the Mobile Home Industry," Massachusetts Institute of Technology, 1972.
7. Masters Class, Department of Architecture, Massachusetts Institute of Technology, "Housing Systems: Seven Studies for Factory Produced Concrete and Steel Modular Units," Massachusetts Institute of Technology, 1972.
8. Massachusetts Institute of Technology, "Feasibility Study of Industrialized Housing Systems," Massachusetts Institute of Technology, 1969.
9. Rabeneck, Andrew, David Sheppard, Peter Town, "The Structuring of Space in Housing: An Alternative to Present Design Practice," Progressive Architecture, June, 1975.
10. "Spancrete Five," San-Vel Concrete Corporation, 1974.
11. "Span-Deck Technical Handbook," Span-Deck Incorporated, 1974.
12. Ting, Kay Louise, "Concrete Box-Units for Housing," Massachusetts Institute of Technology, 1975.