

DESIGNING A RESIDENTIAL ENVIRONMENT:
RECYCLING THE SHATTUCK SCHOOL
AS THE FOCUS OF A NEW RESIDENTIAL DEVELOPMENT

by

Lorna June Giles

S. B. - Massachusetts Institute of Technology

1975

Submitted in partial fulfillment of the

requirements for the degree

Master of Architecture

at the

Massachusetts Institute of Technology

June 1977

Signature of Author _____

Department of Architecture, May 1977

Certified by _____

Anne Vernez-Moudon, Assistant Professor of Architecture
Thesis Advisor

Accepted by _____

Wayne V. Andersen, Chairman, Departmental Committee for Graduate Students





Room 14-0551
77 Massachusetts Avenue
Cambridge, MA 02139
Ph: 617.253.2800
Email: docs@mit.edu
<http://libraries.mit.edu/docs>

DISCLAIMER OF QUALITY

Due to the condition of the original material, there are unavoidable flaws in this reproduction. We have made every effort possible to provide you with the best copy available. If you are dissatisfied with this product and find it unusable, please contact Document Services as soon as possible.

Thank you.

The images contained in this document are of the best quality available.

DESIGNING A RESIDENTIAL ENVIRONMENT:
RECYCLING THE SHATTUCK SCHOOL AS
THE FOCUS OF A NEW RESIDENTIAL DEVELOPMENT

Lorna June Giles

Submitted to the Department of Architecture on May 12, 1977 in partial fulfillment of
the requirements for the degree of Master of Architecture

ABSTRACT

Due to the serious decline in the national birthrate there are a variety of school buildings that are unused, and have become prime candidates for recycling projects. These buildings are in need of some general repair, but are usually structurally sound and could be used to fill some of the needs of their community. In response, this thesis is a prototypical study dealing with the recycling (adaptive re-use) of such a building for housing application.

The model used in this study is the one hundred year old Shattuck School, located in Norwood, Mass., a suburban setting about 15 miles south-west of Boston, Norwood has a need for the low-to-moderate income multi-family housing which this study proposes.

Several issues arise in dealing with the adaptive re-use of this school and its site. Some of these are the integration of this development with the surrounding neighborhood in terms of scale, massing, form, and density, as well as the resolution of a program to provide variety and amenities along with the basic needs.

The existing conditions for the site and school building are examined. These constraints cause this to be primarily a site problem, and for this reason conceptual studies are done at the site level. A concept is chosen then developed into a scheme. Finally the school building itself is conceptually analyzed to show alternative possibilities for its development.

Thesis Supervisor

Title

Assistant Professor of Architecture
Anne Vernez-Moudon

TABLE OF CONTENTS

	Page
ABSTRACT.	2
INTRODUCTION	4
EXISTING CONDITIONS	7
PROBLEM DEFINITION	12
PROGRAM	20
CONCEPTUAL ANALYSIS - SITE	22
PROPOSED SITE PLAN	33
HOUSING MODULES.	43
THE SCHOOL BUILDING.	59
CONCLUSIONS	73
BIBLIOGRAPHY	74
APPENDIX.	75

INTRODUCTION

This thesis is a prototypical study dealing with the recycling (adaptive re-use) of the Shattuck School in Norwood, Massachusetts. The building itself is small; three stories with 6,000 square feet per story. It is situated on a four acre site at the top of a flattened hill. The school is of masonry bearing wall construction.

The issue of recycling stems from a deep concern about the destruction of unused buildings which may be in need of some general repair but on the whole are structurally sound. Because of the serious decline in the national birth rate, there are a variety of school buildings that fall into this category; some are empty, others under utilized. The potential of these older schools built perhaps a century or so ago but no longer used for their originally intended purpose is the subject of this thesis.

Perhaps those located in communities needing additional or different types of housing can be integrated with the community's existing housing to provide a viable alternative living environment where the school building itself can be used as part of a new development symbolizing both the community's respect for and remembrance of the past.

This project is intended to demonstrate the possible uses of the one hundred year old Shattuck School as a model. I am proposing the conversion of the school into residential units to be combined with new housing construction on the site. This arrangement will provide multi-family mixed housing (families, singles, elderly) for low to moderate income persons. This type of housing is lacking in Norwood and in many other suburban towns today.

Many governmental and institutional bodies have either proposed or implemented fair share housing plans since 1970. Fair share housing plans typically determine where housing, especially low and moderate income units, should be built within a region. This is according to such criteria as - broadening the economic mix in communities, and the placement of housing in environmentally suitable locations. The Metropolitan Council (for Minneapolis-St. Paul Area), The Miami Valley Regional Planning Commission (for the Dayton Area), and The Washington Council of Government (for the Washington D. C. Area) are a few examples of agencies which have implemented such plans; the latter two having elicited widespread approval and acceptance by the suburbs.

Massachusetts has also implemented such a plan. An equal share strategy is used which says that all areas within a region should have the same obligation to establish equitable minimum percentages of low and moderate income housing. Between 1971-73 almost 50,000 low and moderate income units were constructed in Massachusetts under subsidy programs for HUD, Massachusetts Department of Community Affairs, Massachusetts Housing Finance Agency, and others. A considerable amount of this construction has taken place in suburbs, which has significantly broadened Massachusetts' suburban housing mix.

Norwood is now being considered by the Massachusetts Department of Community Affairs for conversion into housing of this type. The Shattuck School site is being studied for an elderly housing application. The character of the new development seems to be a key issue where the new development needs to be integrated with the larger neighborhood community. Most housing projects are viewed as self-contained entities, even if they are on a street and surrounded by

other housing. In most cases there is stigma attached to housing "projects".

In a mixed development, interaction between families, singles and elderly on the site would hopefully be stimulated. There should be a constructive environment where resources could complement necessities and where participation in communal activities is stressed.

In order to implement such a program, one must

- design to encourage interaction and/or privacy.
- design homes with room for personalization, possibly growth, and change according to personal taste or "life style".
- design different types of spaces for communal use, somewhat defined regarding intended use.
- provide a wide range of options in unit type, size, location, and character.

Existing Conditions

Norwood is a town located 15 miles south West of Boston. The map in Figure 1 shows the downtown area and its relationship to the Shattuck School (upper middle). Just above the center of that map is the major artery, Washington Street, which houses the commercial/retail district. Most of Norwoods shopping and entertainment (restaurants, and movie theatres, offices) is in this area. The hospital, library, and municipal building (town hall) are also located along Washington Street. Nahatan Street is a secondary artery which runs the length of the map, crossing Washington Street in Norwood Square. The fire and police stations are located on Nahatan Street, as well as several churches, and schools, including the Shattuck School.

Figure 2 focuses on the Shattuck School site and its relationship to the buildings surrounding it. The area is almost totally residential with the exception of a food and dairy market, beauty parlor, and a plumbing, heating and appliances store directly across from the school on Fulton Street. Further down Nahatan Street there is a delicatessan and a Catholic school.

Figure 3 shows a site model of the school as it exists with its surrounds.

Figure 4 is a group of photographs showing the scale and style of the local housing in Norwood. These examples are taken from the area directly adjacent to the Shattuck site, and are representative of the norms for housing there.

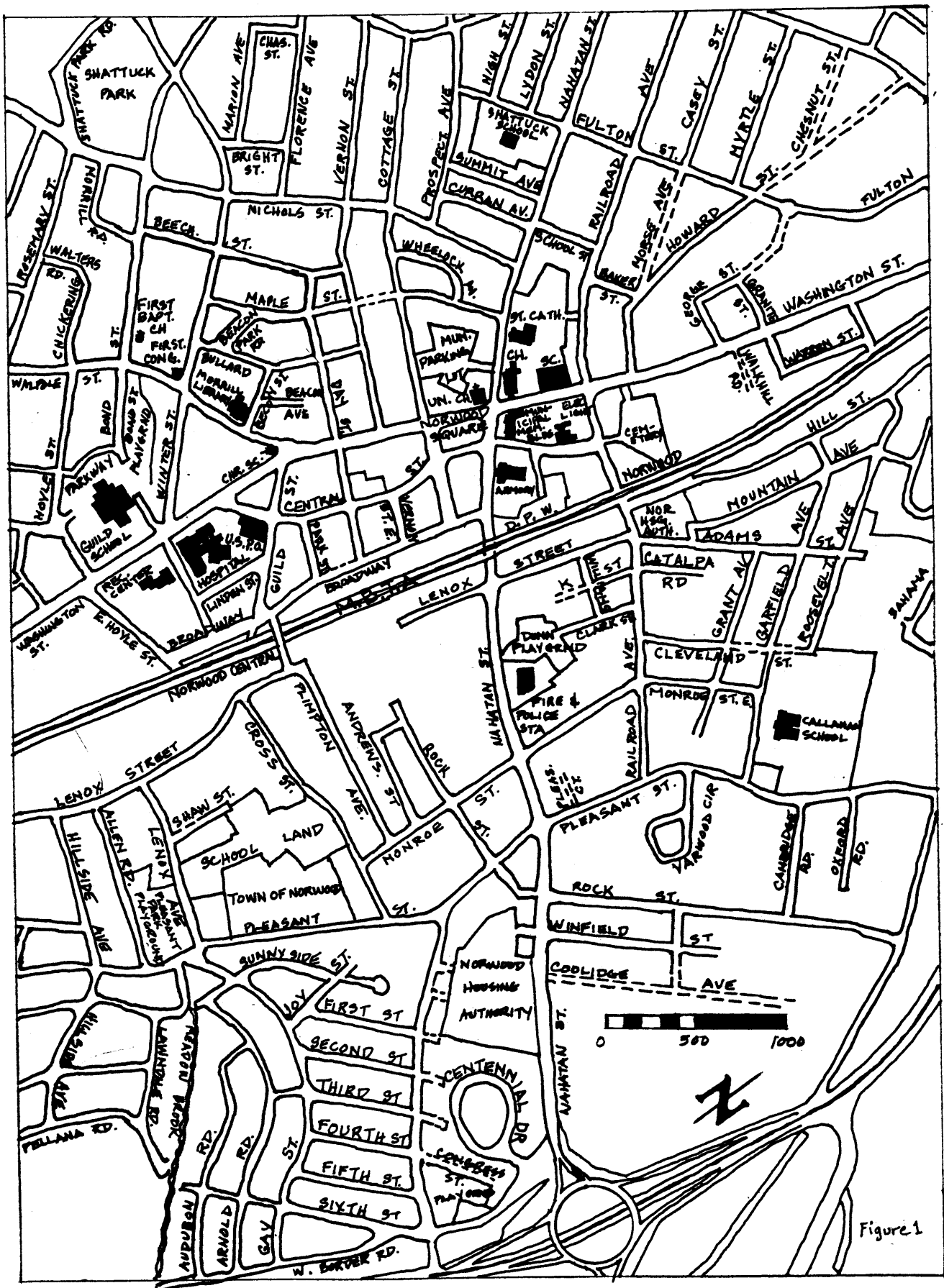

Figure 1

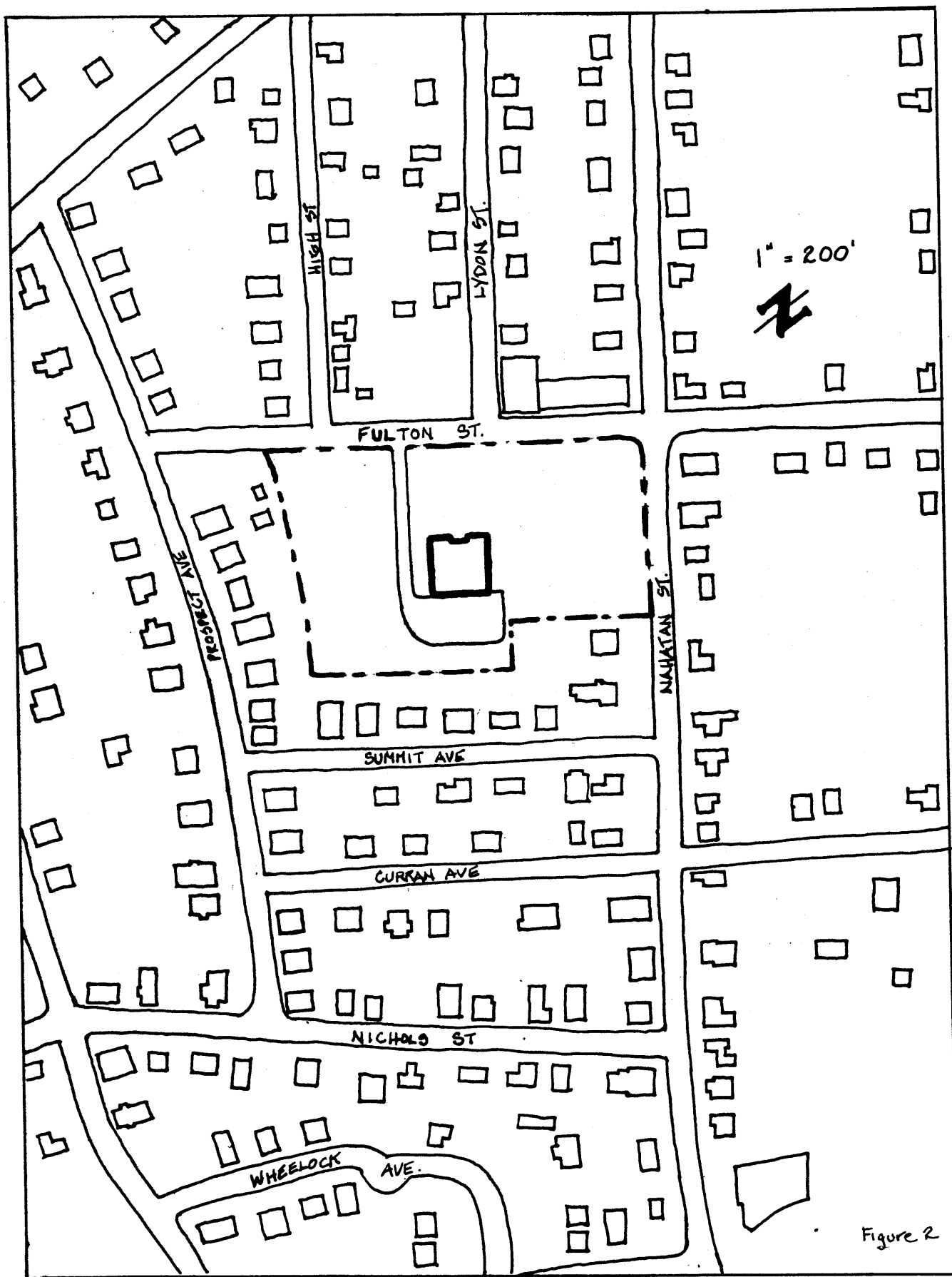

Figure 2

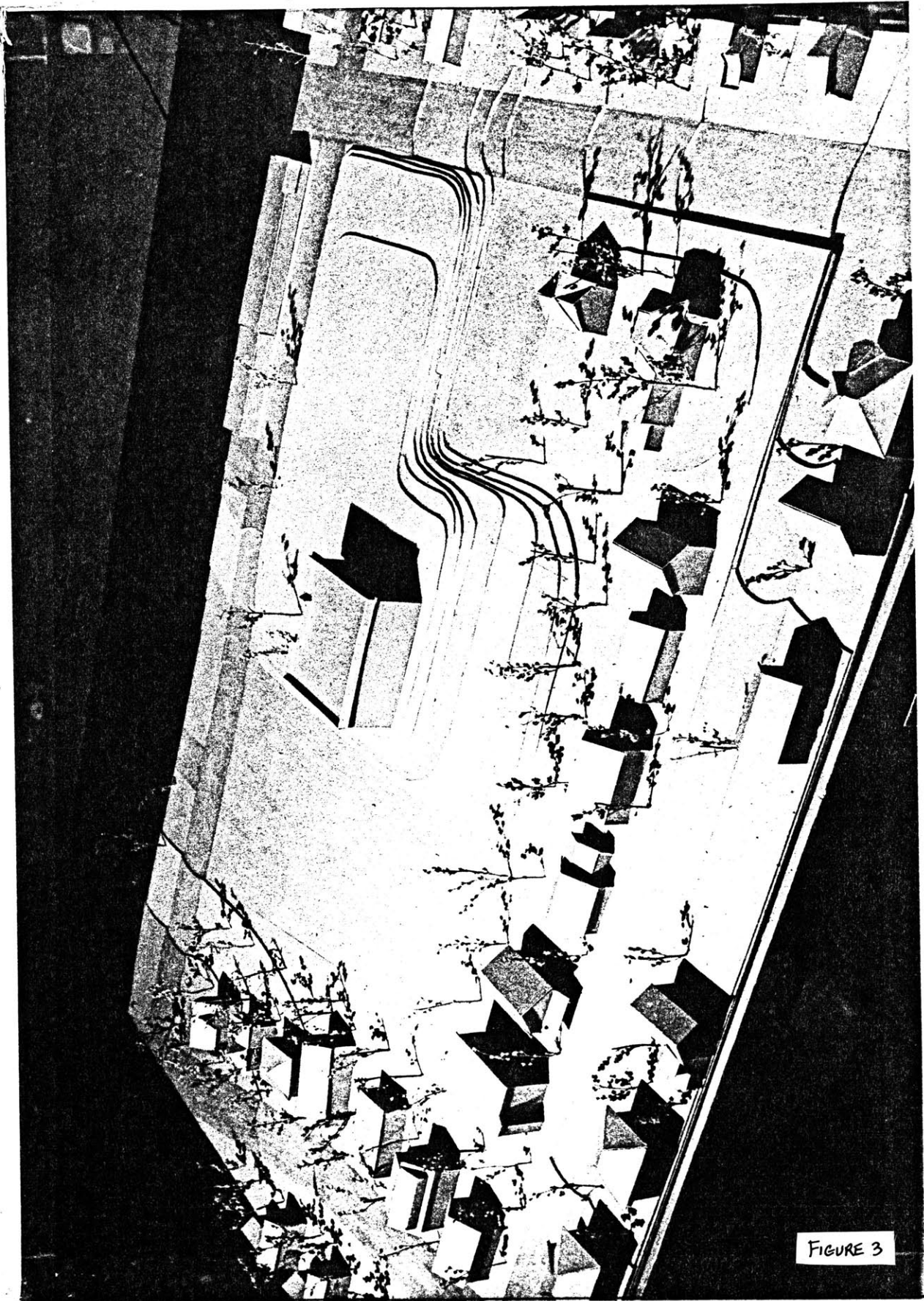

FIGURE 3



NORWOOD TYPE HOMES

FIGURE 4

Problem Definition

After viewing the existing conditions of this particular site, the problem becomes primarily a site problem, rather than a recycling problem, due to these issues:

- 1.) Scale and massing - the school is surrounded on two adjacent sides by low density residential elements of rather small scale (see Figures 1 and 4) while the school's mass (a low square building) is of an entirely different scale.

Further, the school is set on a hill, far back from the street which emphasizes its monumental character and makes the perceived scale difference between it and the surrounding residential elements even greater. See Figure 3.

- 2.) Scale and formal image - the school's image is perceived as non-residential. A possible approach to this problem is to soften or alter its exterior in order to make it more desirable as housing within the community. (Figures 5-8.)
- 3.) Density - the housing density in Norwood ranges between 4 and 6 dwellings per acre. In order to accommodate low to moderate income housing the site density needs to be increased to about 15 dwellings per acre (a medium density by MHFA standards). Blending the proposed density with the existing density of the surrounds is important.
(Figure 2.)
- 4.) Uses and Program - the school itself can be used in many ways: as a

community center, an athletic center, or even as an extension of the commercial activity across the street. Housing however, is also a feasible alternative use, given Norwood's need for multi-family housing. The D. C. A. seems supportive of this reasoning since they are actually proposing a similar use. The housing approach is used in this study for that reason.

The program chosen is a very general one, allowing the necessary freedom to explore different site arrangements and housing types. The provision of open space is important, since maintaining a similarity between this development and the surrounding community is one of the goals. Figure 2 shows the large amounts of open space present in residential blocks in the school's vicinity.

Figs. 5-8 show photographs of the Shattuck School as it exists. The different views are keyed on the diagram below.

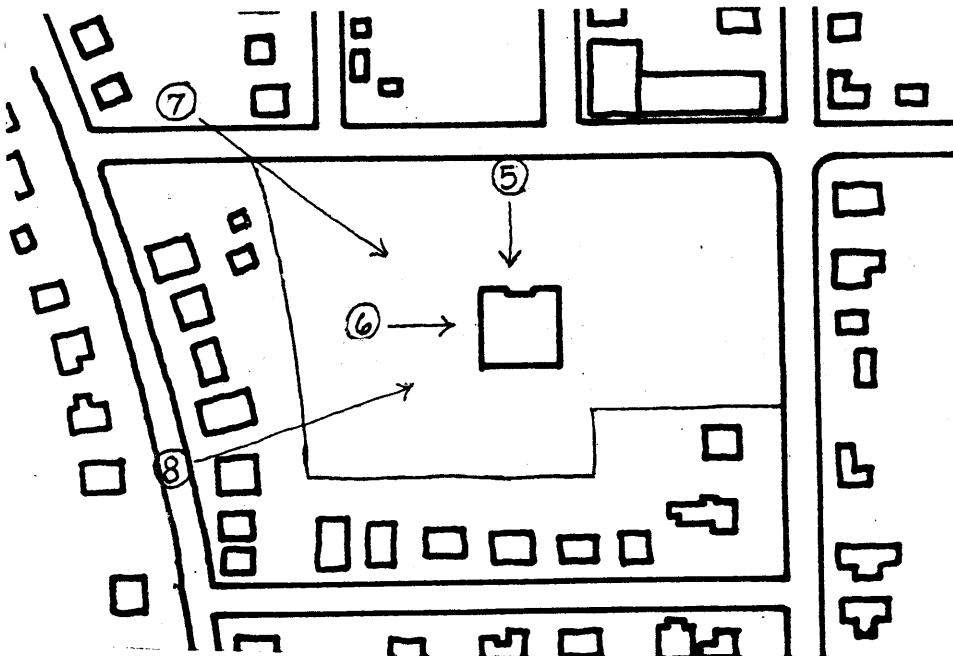

Figs. 9 and 10 show the existing plans and sections of the Shattuck School.



FIGURE 5



FIGURE 6

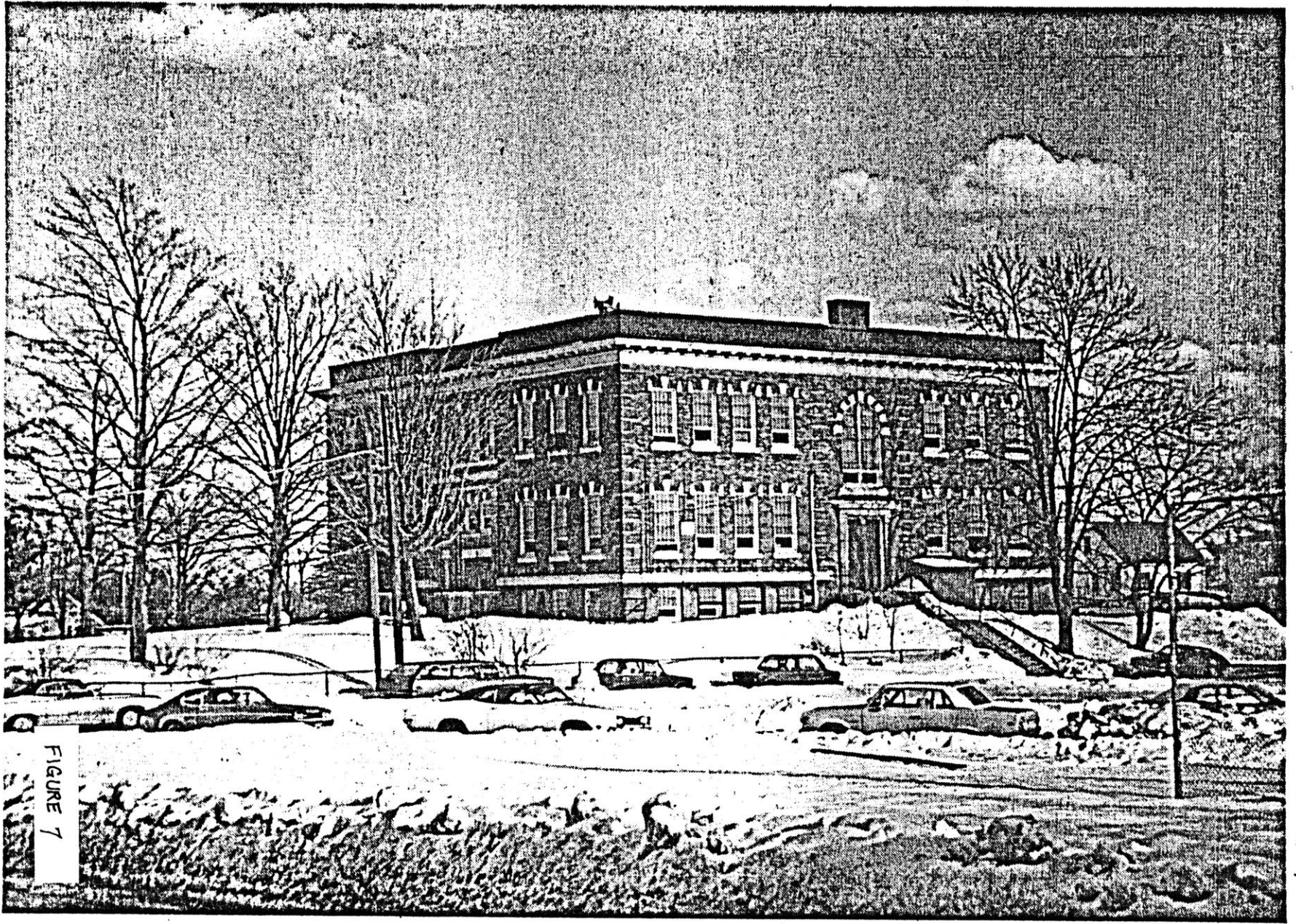
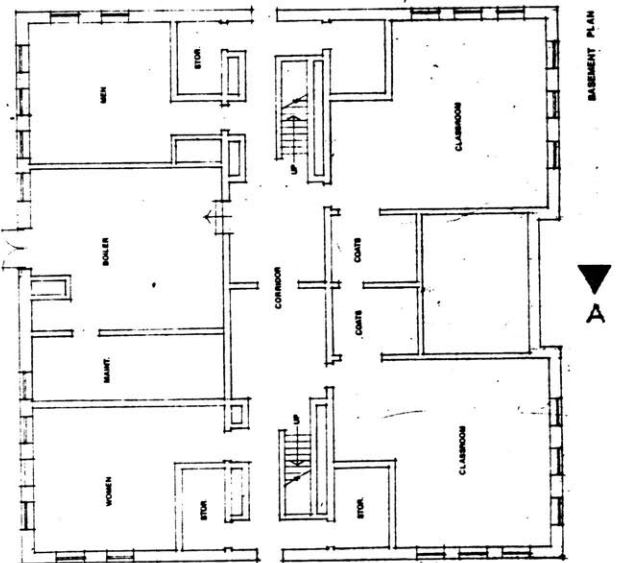
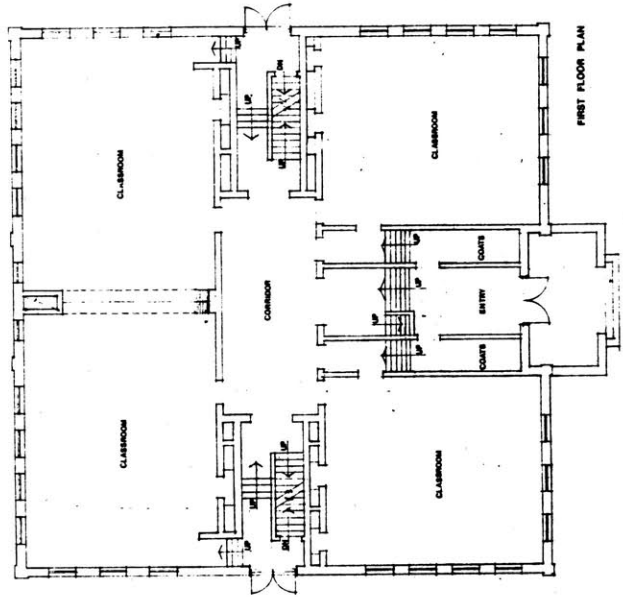
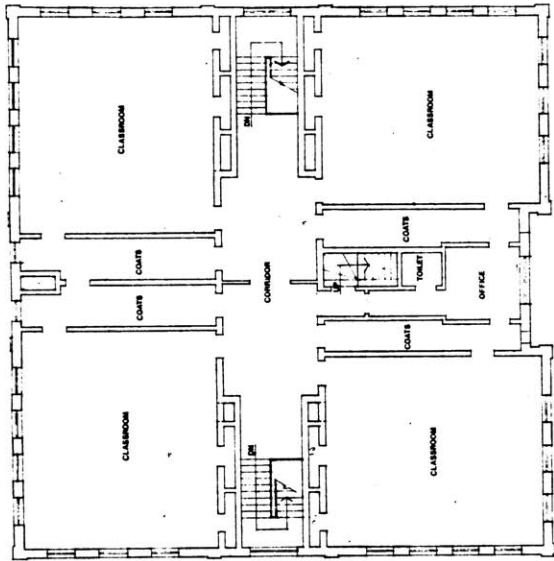

FIGURE 7



FIGURE 8



▼
A

▼
A

SCHOOL PLANS
EXISTING
FIGURE 9

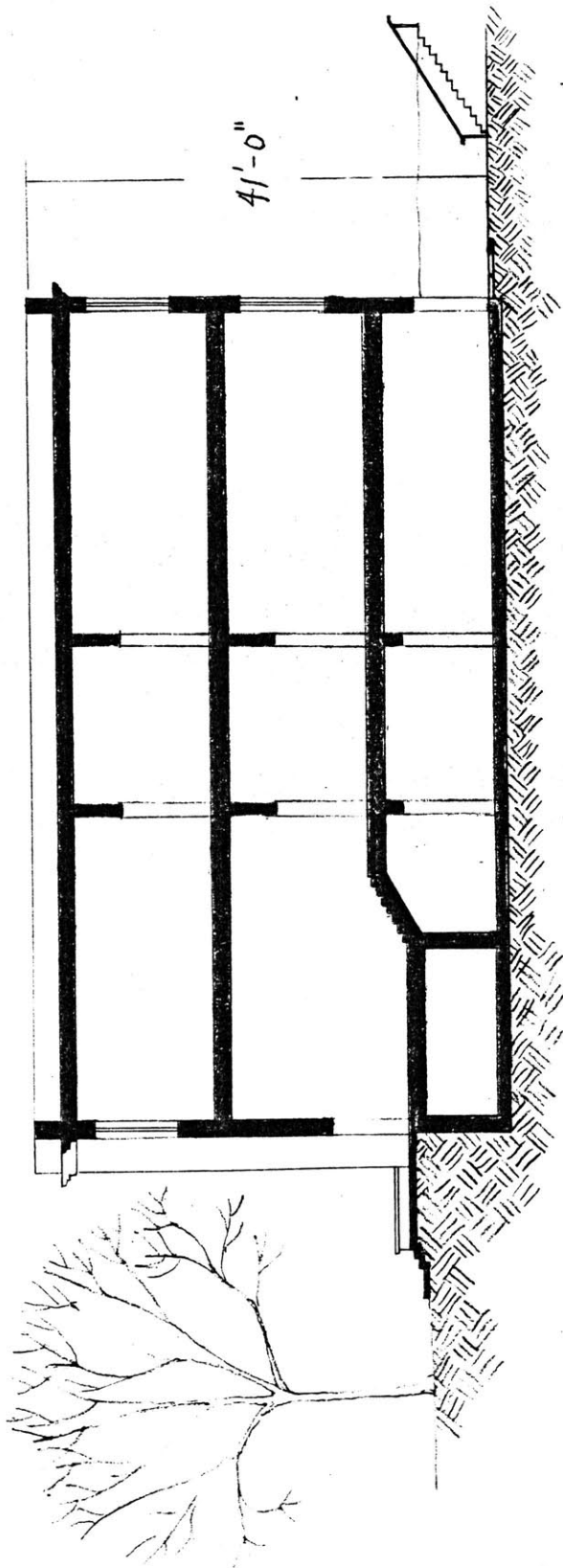

41'-0"



SECTION A-A
FIGURE 10

The Program

Since a net density of 15 dwelling units per acre is desired on this four acre site, the total number of units needed is 60.

School building:

- dwelling units: 15-20, both flats and duplexes ranging in size from studio to 3 bedroom
- communal space: Function Room (multi-purpose) and Kitchen
Laundry
Sitting & Chatting Semi-Private Area
Childrens Indoor Play
Lobby; Mail Area
- Manager Office and Apartment
- Mechanical Space
- Tenant Storage

New Construction on the site:

- dwelling units: 35-45 units, flats, duplexes, and triplexes ranging in size from 1 bedroom to 5 bedroom
(some % of this geared towards elderly occupation)
- communal space: Outdoor Play - hard surface, green
Quiet Sitting Area
Barbeque Area
Garden Area - for tenant use
Pedestrian pathways
Parking Area

Along with this general program, certain basic provisions for each dwelling unit are considered. These are:

- light, and air circulation - south light in living areas wherever possible, as well as the possibility of cross ventilation.
- private outdoor space - wherever possible, giving extra opportunity for personalization, gardens, recreation, display, and generally pride in one's home.
- vehicular access - wherever possible for convenience as well as for emergency purposes.
- parking near or at the dwelling units for at least 75% of the units; on the street around the site for the remaining 25%.

Conceptual Analysis - Site

In this section, conceptual diagrams are used to illustrate site planning possibilities. Four basic variables exist within the program constraints regarding site arrangement. They are:

I) Vehicular circulation through the site - how to penetrate the site in order to bring cars to the units for both access and parking. The vehicular circulation method chosen for this particular site to a large extent, dictates the way the other variables can be handled. Site penetration can be handled in two ways: inserting a through street or using cul-de-sacs. There are variations on either theme.

The first method provides the option of placing housing anywhere on the site since a road can access everywhere. Cul-de-sacs, generally leave some area unpenetrated, suggesting open space, (undisturbed by traffic), rather than housing (only having pedestrian access possible).

Another factor involved with choice of vehicular circulation is the "quality" of the street which can vary between public "city-like", semi-private street or drive, private lane or alleyway.

Handling the vehicular circulation using a through street can provide a street which is either city like, or semi-private, depending on its width and the materials used for paving. In order to offer a quality more like a private lane, one might have to place gates on the entrances.

If one used the cul-de-sac approach, just by that type of streets nature (i. e. dead end sign, streets termination clearly in sight) one is assured a quality which is at least semi-private if not completely private.

II) Type of housing - the variables in type:

- a) detached houses
- b) row housing
- c) clusters

Detached houses would yield a lower density, the maximum yield being 8 dwellings per acre net, while row houses or clusters can yield higher densities (12 dwelling units per acre net, minimum).

In striving to maintain the feeling of the Norwood housing pattern, detached houses with lower densities should be located around the sites perimeter to continue the existing fabric. Rows, clusters or other more dense forms should be located inside the site.

III) Relationships between housing - the housing on the site can relate to the city streets, internal streets, or open spaces.

IV) Open space - this can vary in its arrangement or location. It can be:

- centralized for either semi-private or semi-public use.
- split into separate parcels forming smaller communal entities for each separate area's domain.
- parcels which are linked in order to encourage communal use by the whole site community without feelings of territoriality.

Housing and open space possibilities can be explored based upon a choice of vehicular circulation method. The alternative studies follow. Figures 12, 13, and 14 all use alternative "through street" approaches.

Scheme 1a (Figure 12) illustrates a concept where the housing around the site edges is of the same low density type as is Norwood's norm (single family detached).

It relates outward towards the housing adjacent to the site. Space is left in front of the school, to preserve the school's main entrance and view from the street.

Inside the site, the density increases. There are two rows of housing which relate to each other across the semi-private street. Denser housing which relates to the semi-private street and school on its front, and relates back-to-back with the existing housing that is adjacent to the site, and another dense strip of housing which relates to the semi-private street, and to existing housing backs comprise the remaining groups of housing.

One issue in this concept, is that of scale difference. The housing at the rear of the school is separated from the school by a semi-private street, and there is a four foot level change between the street and the school. Placing the new housing and street in this fashion tends to increase rather than compensate for the difference in scale between the school and the housing.

Scheme 1b (Figure 13) - This concept makes use of a "through street" that is bent. This street configuration helps the street have a more private quality. As the street appears shorter, and its many curves are factors which would discourage the motorist who is lost, or looking for a short-cut.

Around exterior edges is low density, Norwood type housing again. This time it relates inward; having a low density cluster around one edge which relates to a large open space. There is housing at the semi private street entrance to

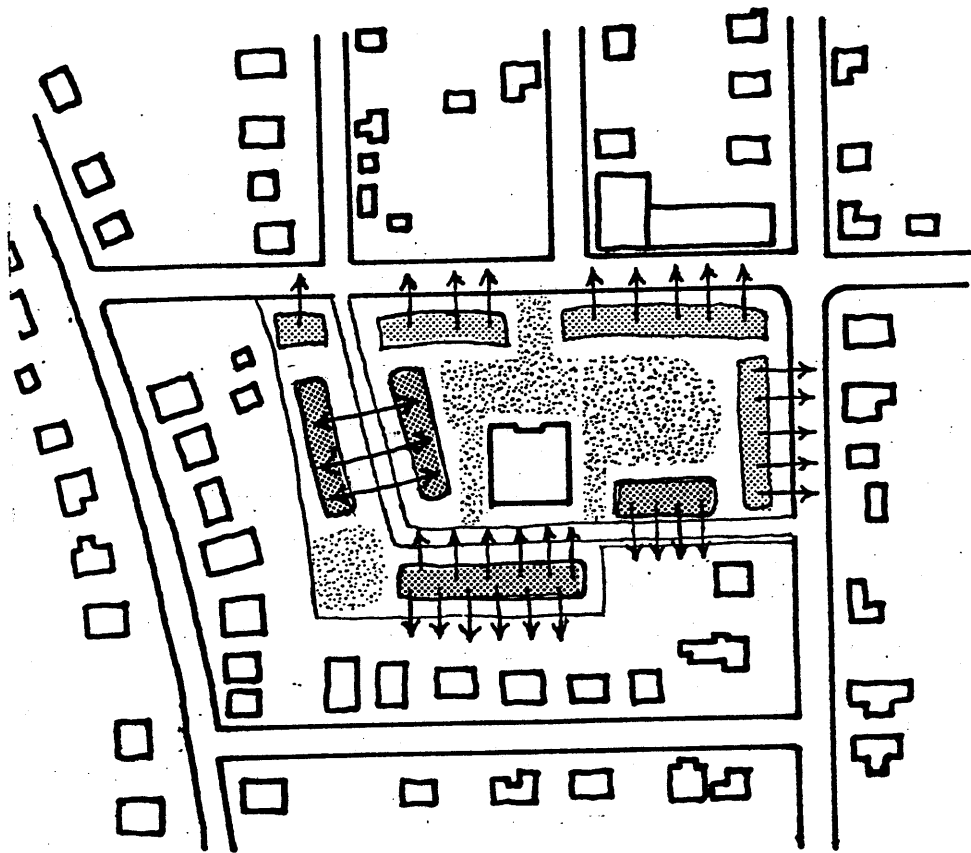
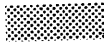



FIGURE 12

-  LOW DENSITY HOUSING
-  HIGHER DENSITY HOUSING
-  COMMUNAL OPEN SPACE

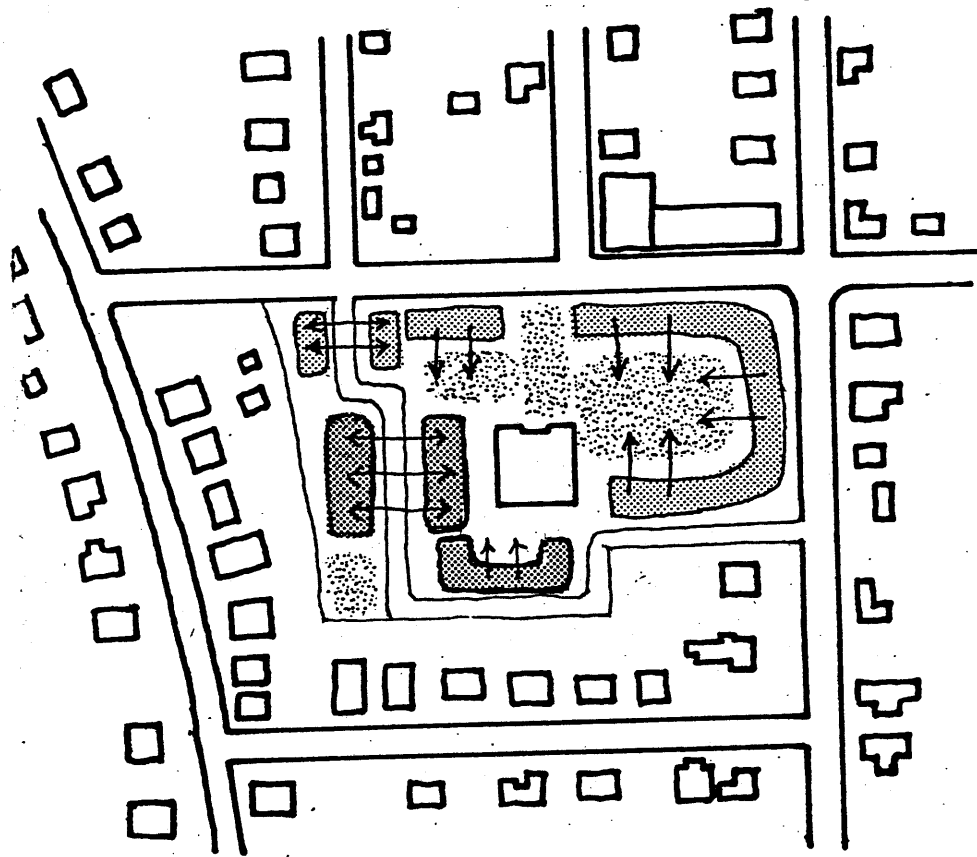





FIGURE 13

-  LOW
-  HIGHER.
-  OPEN SPACE

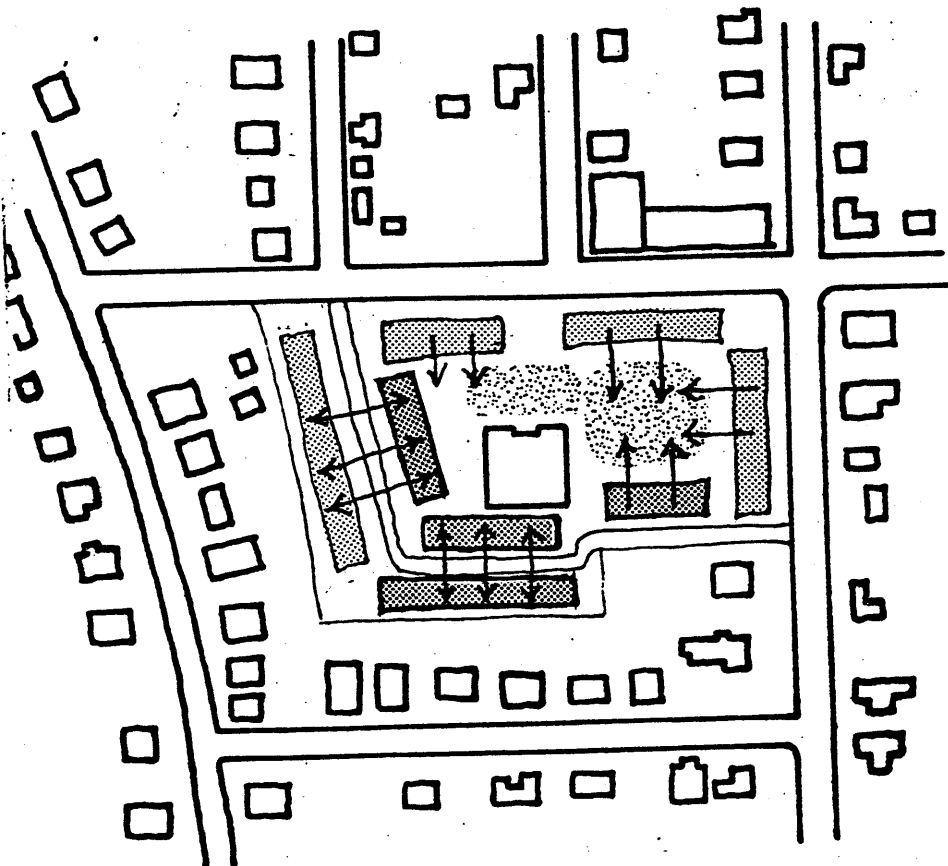

FIGURE 14

block the view into the site. Once inside, there are two strips of denser housing relating to each other across the semi private street, and a different form of dense housing clustered in back of the school. This scheme includes a "plaza" type space at the front entrance to the school, and several separate parcels of open space scattered around the site.

Scheme 1c (Figure 14) - This scheme also uses a bent through street. This one is not as successful at insuring privacy, since its still comparatively straight.

Here too, the housing is arranged in an introverted manner: only the forms are changed. There is low density. Norwood type housing along three edges. At the sides and rear of the school, the density increases.

There is open space in the front of the school only, centralized in two different use spaces.

The major advantage of all these schemes is that they allow the possibility of housing around all of the sites edges (with vehicular access). Another, is that the street can be one-way; no turn around is necessary. For that reason it doesn't have to be very wide, thus giving through streets an opportunity to take on a more private quality.

The disadvantages are that this street configuration (1) doesn't lend itself to dense clusters very well (2) doesn't make large open space in the rear a comfortable alternative; and (3) makes privacy difficult.

Next; Figures 15, 16, 17 and 18 show variations on vehicular circulation method two; the cul-de-sacs.

Scheme 2a (Figure 15) - Shows 3 different cul-de-sacs, one in front of the school building, allowing cars to penetrate as far as the school building; and one each at the other exterior edges.

The housing here relates inward. On the exterior edges is low density Norwood scale/type housing. Inside, density increases and at the roads ends are dense clusters.

The open space is in linked parcels. A "plaza" in front of the school: a smaller parcel to the right and linkage around the school to the rear of the site which has the main communal area for the site residents.

Scheme 2b (Figure 16) - Is similar to 2a in street pattern and open space (except for the plaza). The housing, however is different here. Along the city street edges, the housing relates outward, and is of low density Norwood type/scale. Inside the site the form and density change.

Scheme 2c (Figure 17) - Allows for a somewhat symmetrical treatment of the site. Two cul-de-sacs, one from each edge, enter the site. Around the edges the housing is of low density, and relates outward. Nearest the school, the density increases.

There is a park like open space in front of the school, and a large open space in the rear of the school.

Scheme 2d (Figure 18) - has the same street pattern as 2c, but the housing type/form differs. Along Fulton Street, the front site edge, is low density housing, while inside the site dense clusters surround the cul-de-sacs.

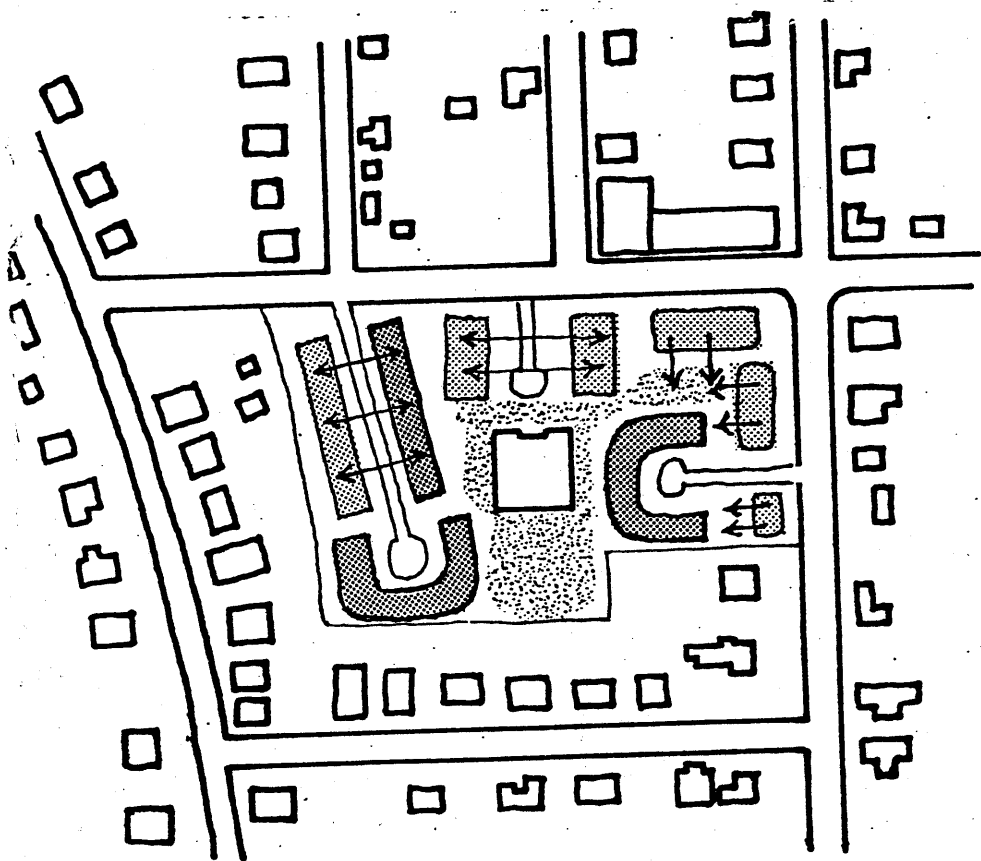





FIGURE 15

-  LOW
-  HIGHER
-  OPEN SPACE

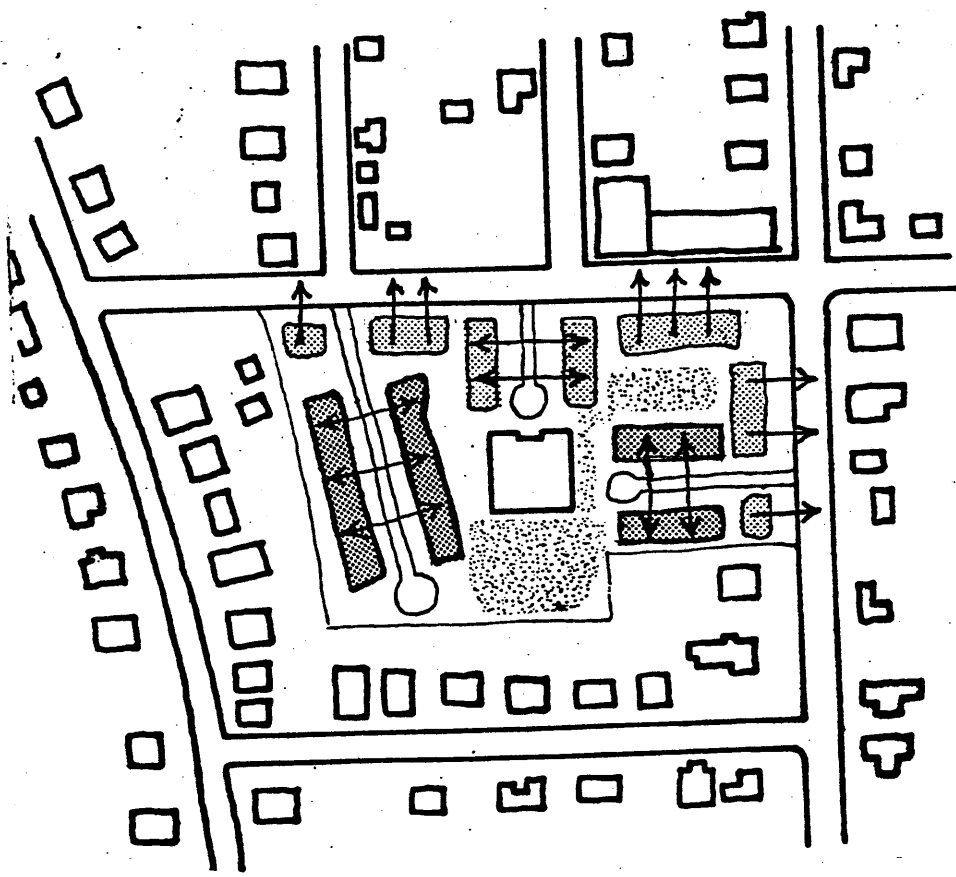

FIGURE 16

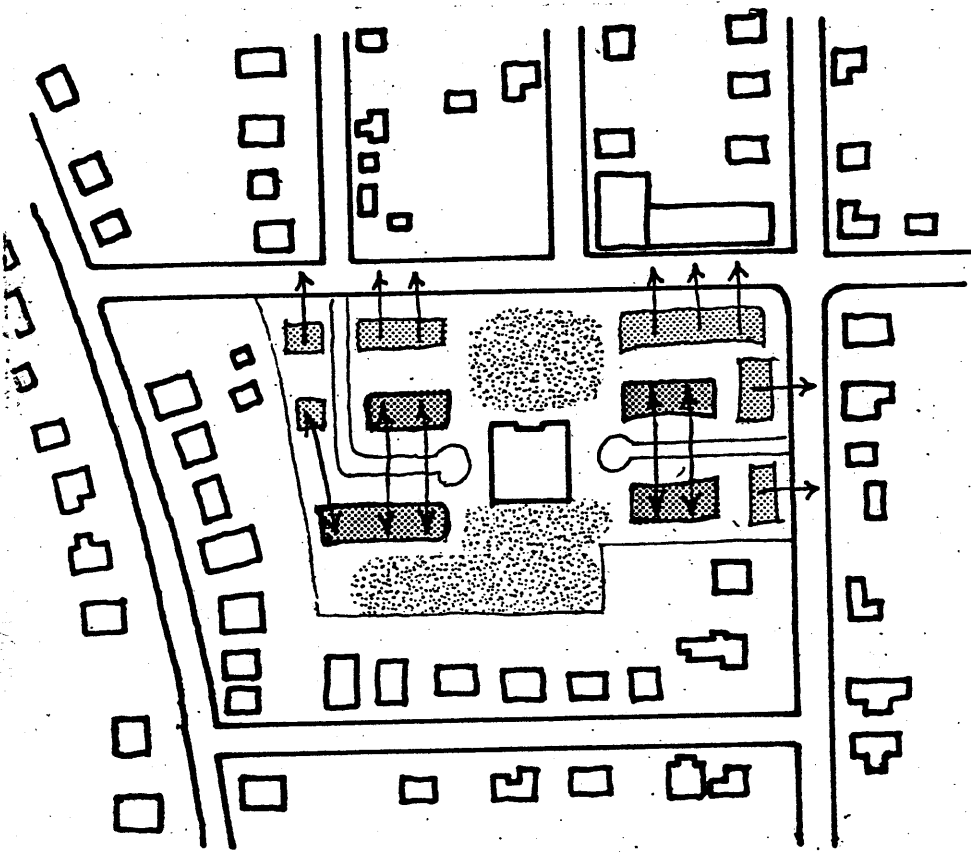





FIGURE 17

-  LOW
-  HIGHER
-  OPEN SPACE

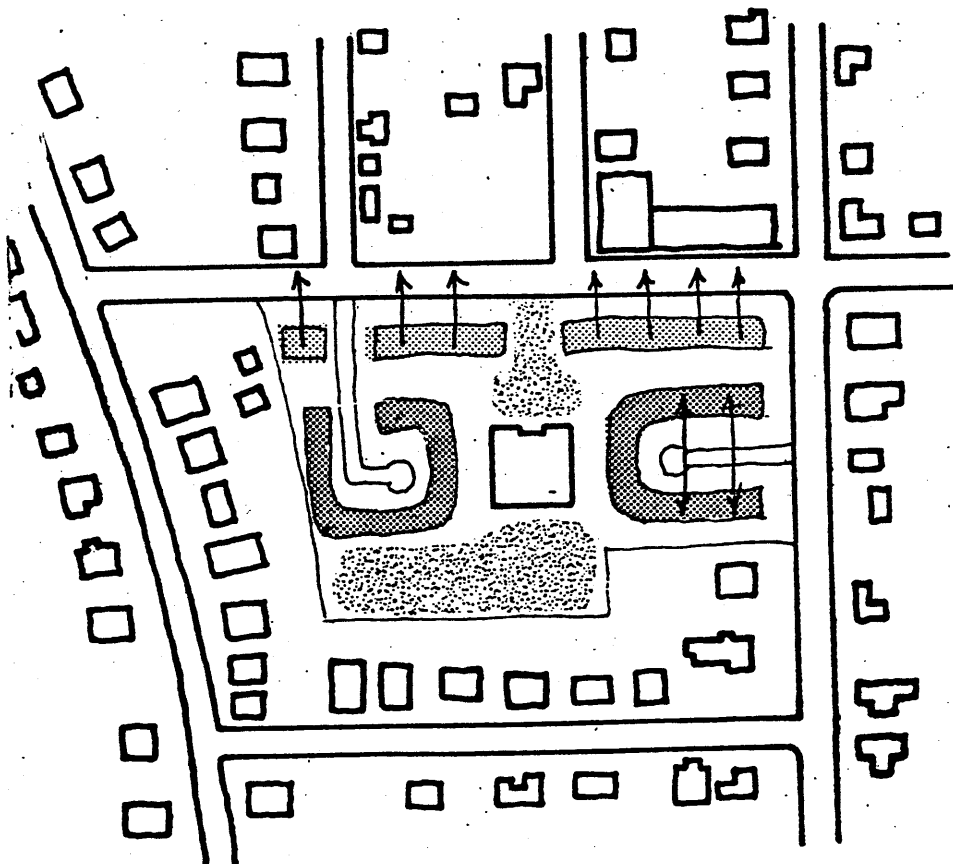

FIGURE 18

There is a smaller plaza at the front entrance to the school, and a large open space at the rear.

Scheme 2e (Figure 19) - makes use of only one cul-de-sac penetrating the site along its left boundary. The housing could be of the Norwood type (i. e. detached) but, perhaps of a bit higher density. At the end of the cul-de-sac, is a dense cluster.

The open space in this scheme surrounds the school, being a plaza in front and a large space, on the right side of the school, both of which can be viewed by the larger community. Here, the outside is invited in to share this largest open space. There are smaller spaces at the other sides of the school which would be for more semi-private use.

Schemes 2a, 2b, and 2e - allow for a wide range of housing types. The street pattern is one which would allow a semi private/private street quality, as well as a sheltered open space area well back from the city streets. They make possible a standard Norwood treatment on the site edges, while permitting something entirely different in type and form, inside the site, to occur.

Schemes 2c and 2d illustrate a disadvantage, because the cul-de-sacs used in those instances don't penetrate the site far enough. This makes achieving the desired density (60 dwelling units for this four acre site) more difficult, unless higher density types like rows or clusters are used. This is due to the fact that a low rise development is desired to continue the local fabric.

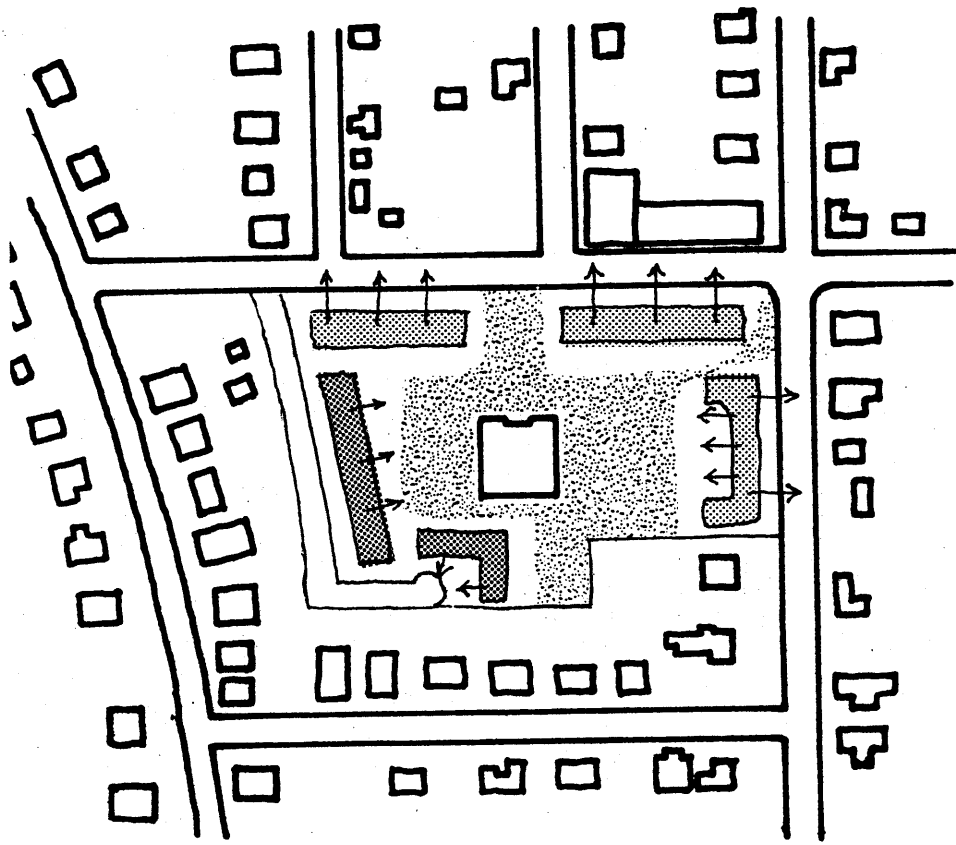





FIGURE 19

-  LOW DENSITY HOUSING
-  HIGHER DENSITY HOUSING
-  COMMUNAL OPEN SPACE

PROPOSED SITE PLAN

The site scheme which developed is a combination of conceptual diagrams 2a and 2b (Figures 15 and 16). The reasons for choosing such a scheme are: (1) the schemes utilizing dead end streets have the advantage of being more private than those using through streets (see discussion of site alternatives). (2) This street pattern encourages the formation of small clusters of housing at the cul-de-sac's ends, which become smaller living groups. Along the cul-de-sacs, row or detached units can appear depending on the desired density. (3) Having cul-de-sacs arranged in this manner allows the formation of a large semi-private rather than semi-public open space that is sheltered from the street while in view of most of the site residents.

The housing in this scheme is of the three types discussed: single detached, short rows, and cluster. In front of the school are homes arranged symmetrically, to reinforce the formality of the school's situation. They reduce the perceived difference in scale between the school and the surrounding housing, since height-wise they are about equal. The roofs are flat and the massing of these homes is similar to that of the school (square proportions).

Around the city street edges are Norwood type homes (single family detached) to continue in the local fabric. The more formal face of these homes relates outward to the existing neighborhood homes. There is a dense cluster at the termination of the left cul-de-sac and a broken cluster at the termination of the one at the right. On the right, half of the broken cluster follows the contour of the site, with housing built on the edge of a seven foot drop. Building out to the edge, allows for

drive in parking underneath these homes. See Figures 20 through 27

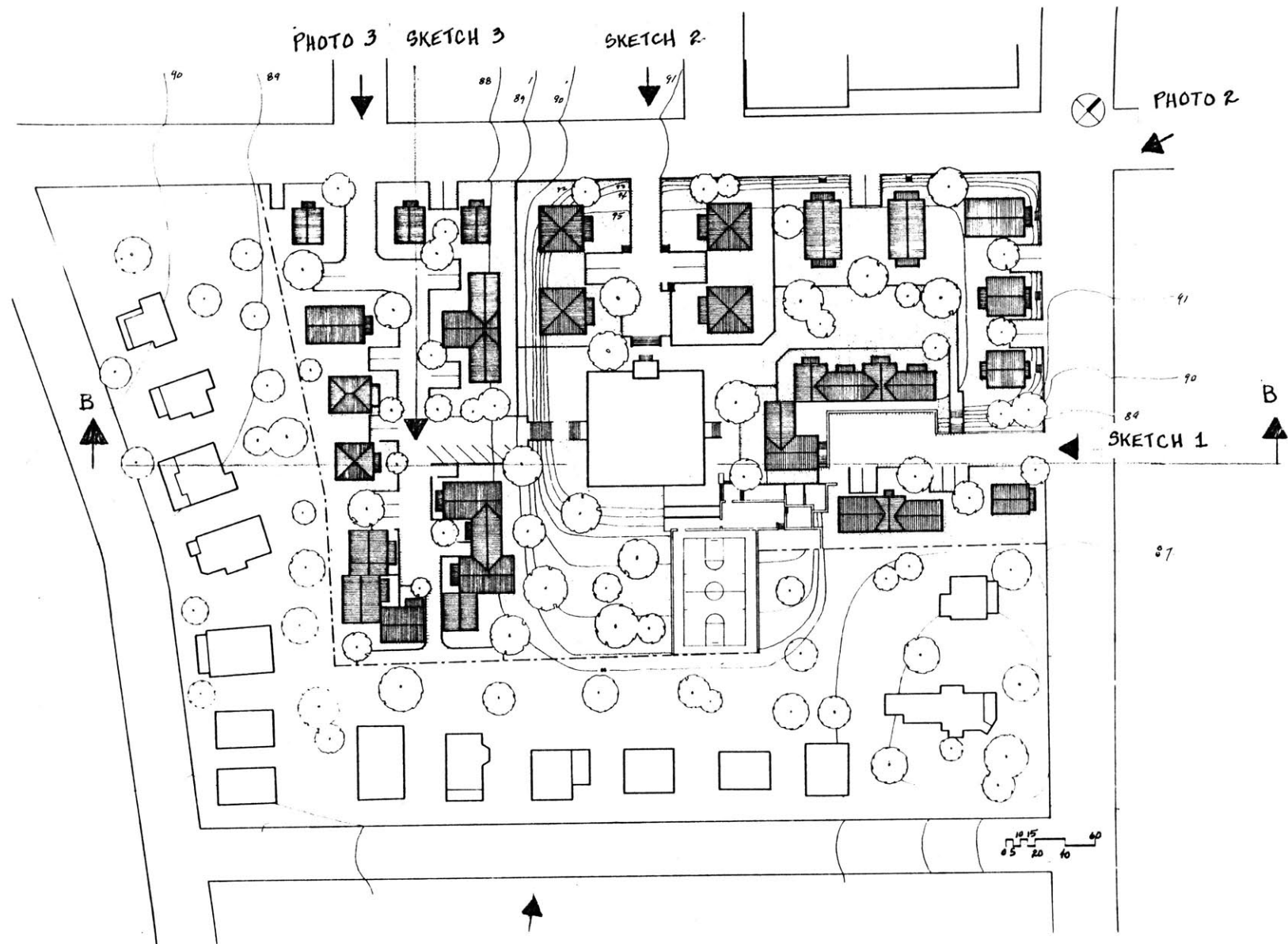

PROPOSED SCHEME
FIGURE 20

PHOTO 1



SECTION B-B
FIGURE 21



SKETCH 1
FIGURE 22



SKETCH 2
FIGURE 23



SKETCH 3
Figure 24

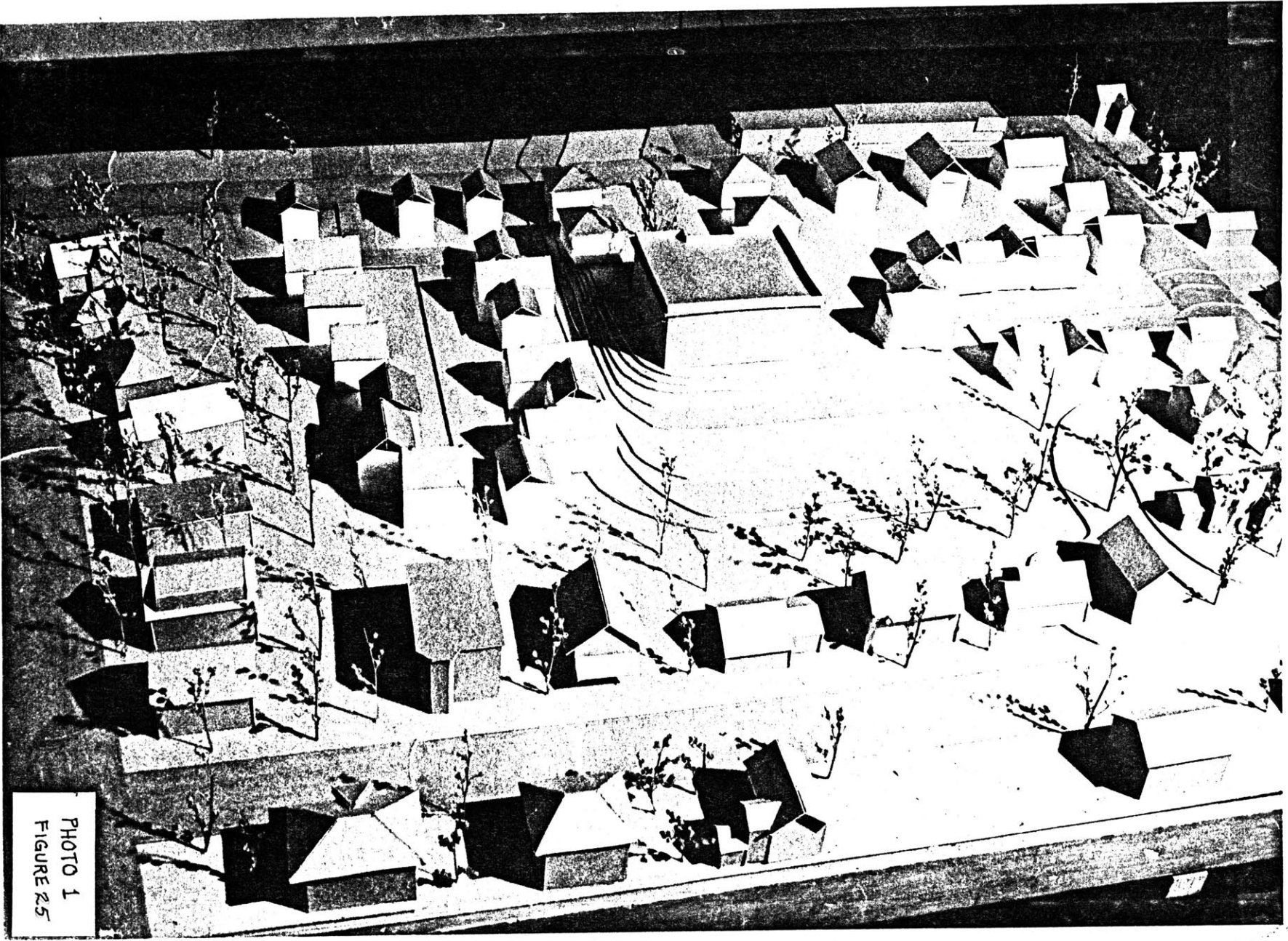

PHOTO 1
FIGURE 25

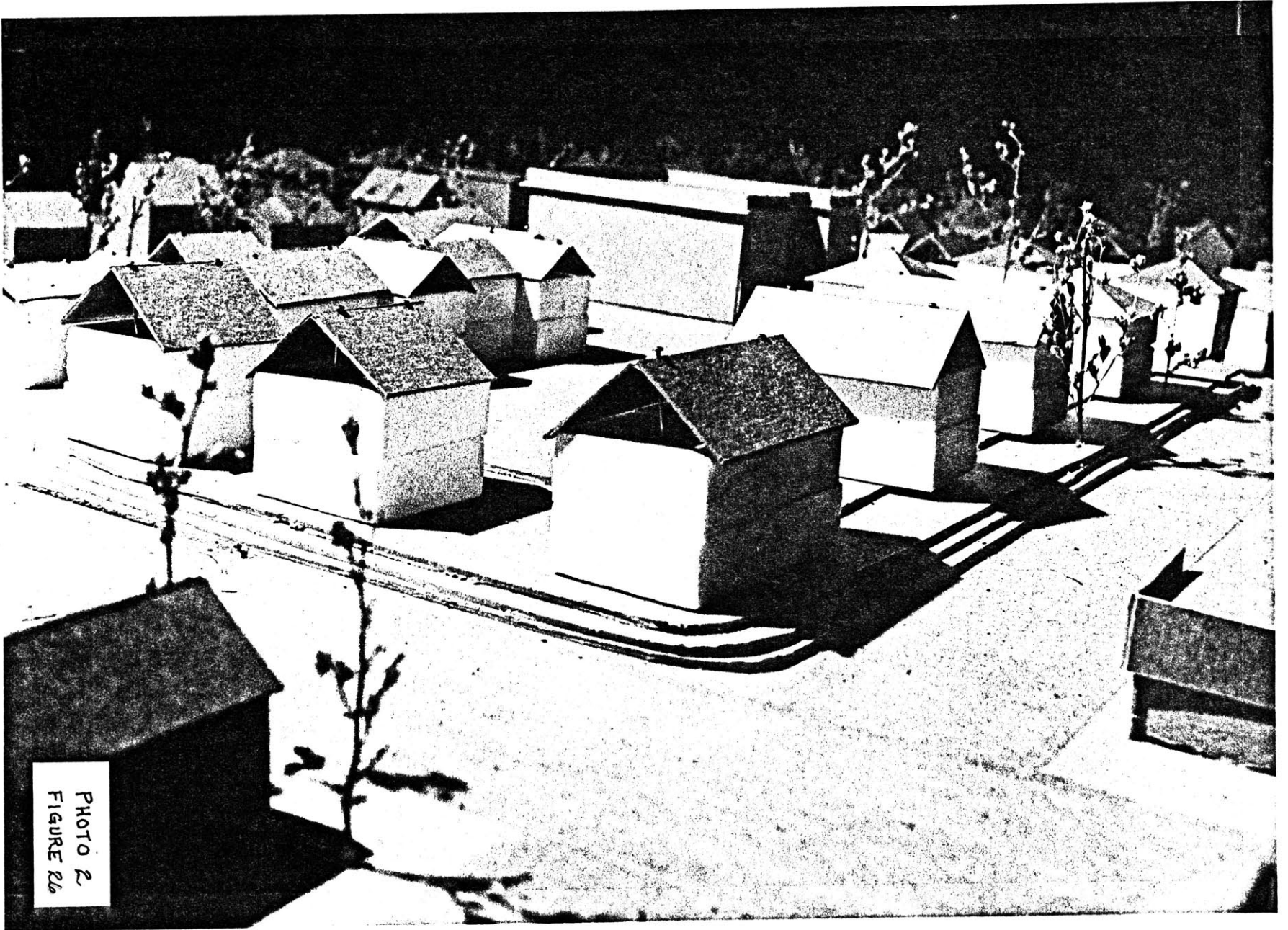

PHOTO 2
FIGURE 26

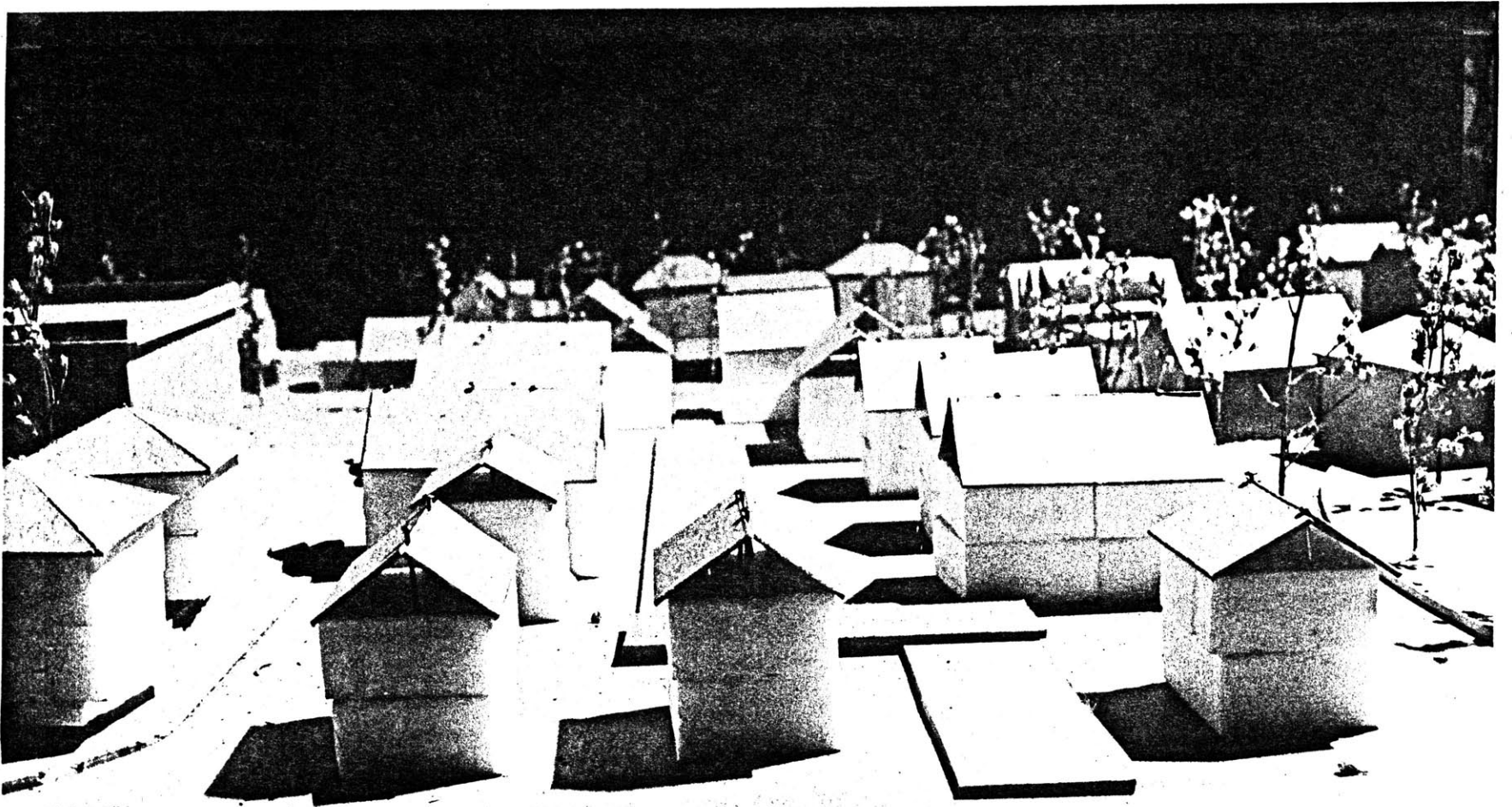

PHOTO 3
FIGURE 27

HOUSING MODULES

There are basically 3 types of dwelling units which make up the housing for the development.

- Apartment type - which would be located within the recycled school building.
- Flats - which are stacked in 2 story (or 2 1/2) homes. These could be detached, rows, or clusters in type.
- Duplexes or triplexes - which are usually of the detached single family type.

See Figure 28 for chart showing unit type breakdown.

In order to initially plan for the different types and sizes of dwellings which were to be added to the site, a system of basic square footages for dwellings was used. The dimensions of these modules were chosen on the following basis:

- First, the different widths (frontages) of the homes in the existing Norwood setting (20-30 ft.) were surveyed; the variety being between 20 and 30 ft.
- Secondly, given the desire to accommodate many different family sizes and types, a basic range for unit sizes (from 500 sq. ft. - 2,000 sq. ft.) was chosen.

The above information was combined such that it would be possible to offer dwellings which would be similar in character and dimension to those already existing in the neighborhood; resulting in the choice of 6 basic modules:

20' x 25'	25' x 30'
20' x 30'	30' x 30'
25' x 25'	25' x 40'

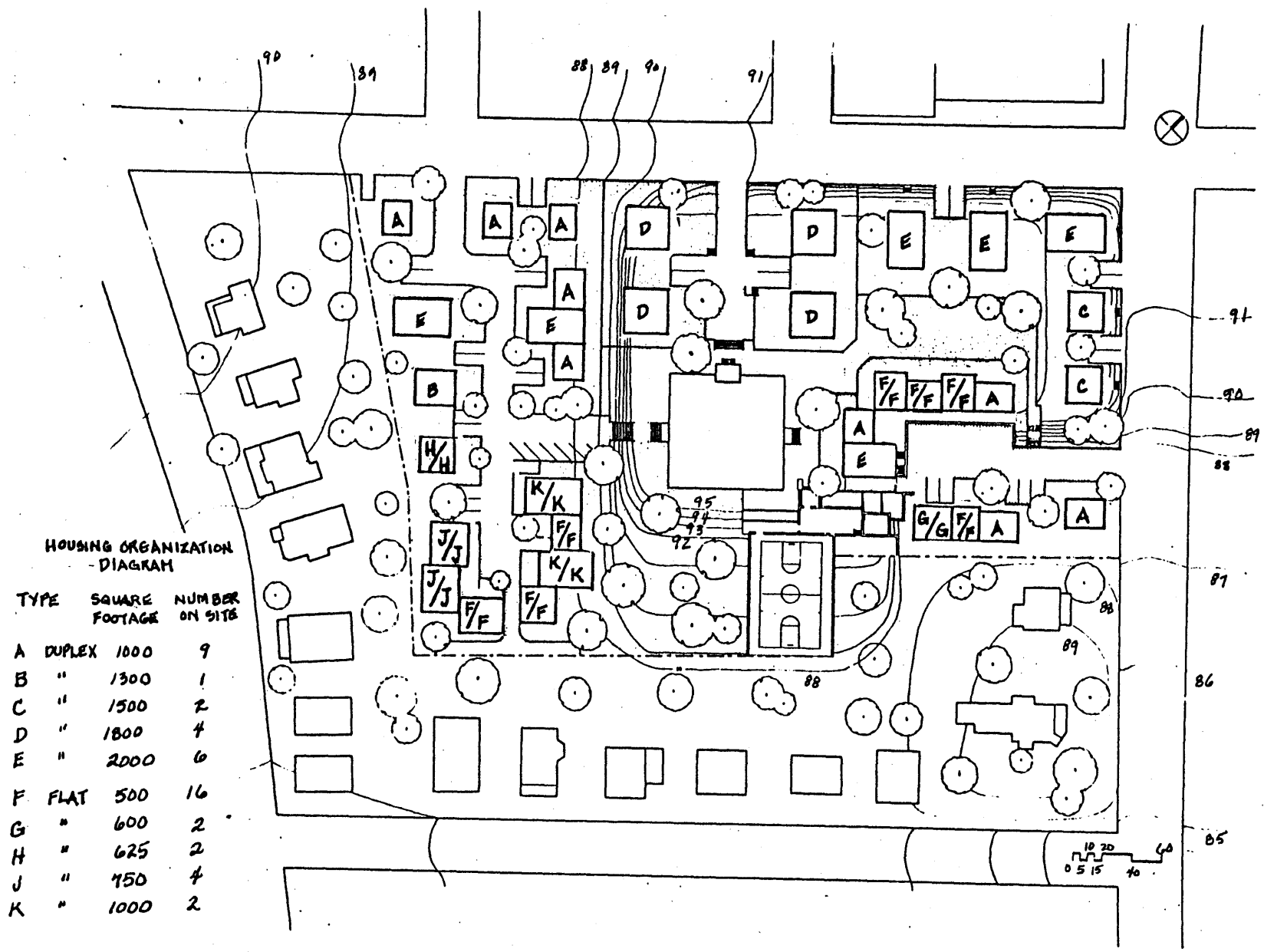

HOUSING ORGANIZATION
- DIAGRAM

TYPE	SQUARE FOOTAGE	NUMBER ON SITE
A	DUPLEX 1000	9
B	" 1300	1
C	" 1500	2
D	" 1800	4
E	" 2000	6
F	FLAT 500	16
G	" 600	2
H	" 625	2
J	" 750	4
K	" 1000	2

FIGURE 28

ff

These modules served as planning aids to generate different types and sizes of dwellings such as duplexes or stacked flats.

In using these modules it becomes necessary to be aware of the type of plan possible in for instance a 20' x 25' module representing a flat, or two of those stacked to indicate a 1000 square foot duplex unit. This is necessary to know where light has to get in, where entrance is possible, and in general what basic organization for public rooms (living), private rooms (bedrooms), services (kitchens and baths) and circulation. Therefore some possible organizational diagrams for each module, either flat or duplex are generated. These diagrams were generated such that light and air can be restricted to only two parallel walls (either two), without penalty to the unit. This allows the units to be attachable for row or cluster formations. In many cases however these modules are unattached and can expect exposure on all four sides. The entrances are indicated.

These are not intended to be final plans, or even a real picture of the final shape of the buildings. At this level of detail however, they indicate:

- 1) The intention towards providing variety even in dwelling units of one size.
- 2) Indications regarding positioning of services (plumbing), the public living spaces, private spaces, and circulation.

Having initially used these modules in locating the different unit types on the site, designing actual plans for the units would have been a step higher in the level of detail. (This study does not reach that level, however.)

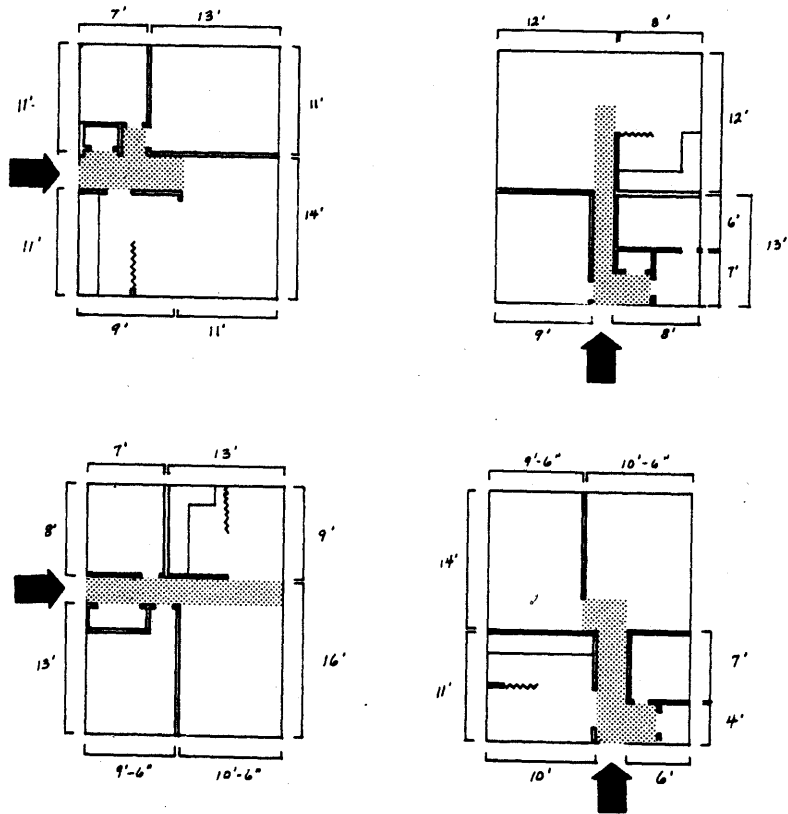

500 SQUARE FEET
 20' x 25' FLAT MODULE

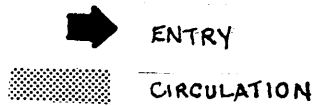
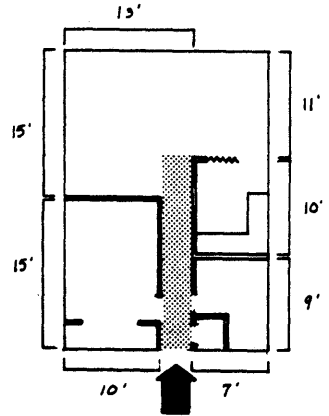
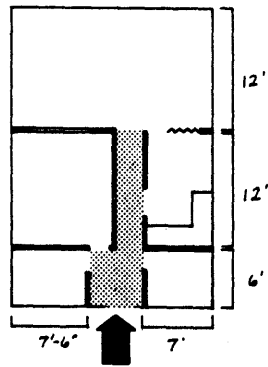
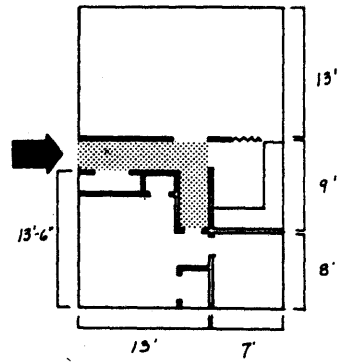
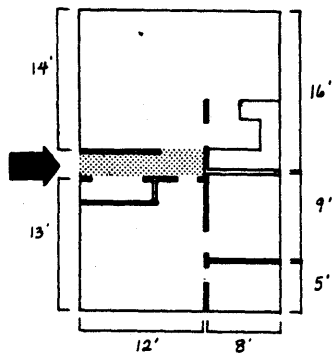
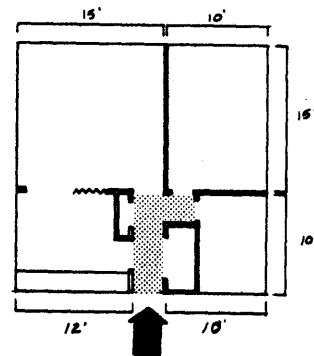
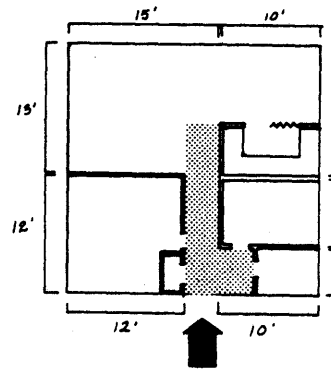
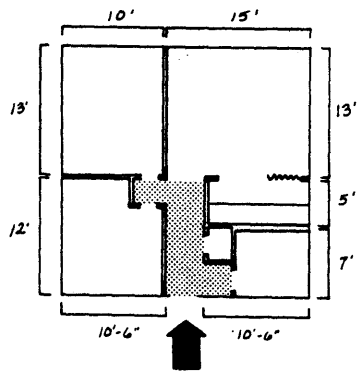

FIGURE 29



600 SQUARE FEET
20' x 30' FLAT MODULE

FIGURE 30



625 SQUARE FEET
 25' x 25' FLAT MODULE

FIGURE 31

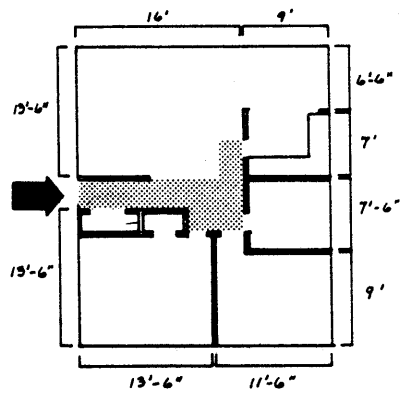
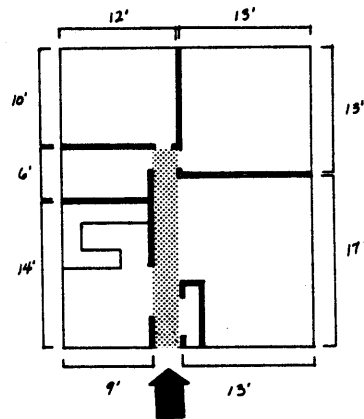
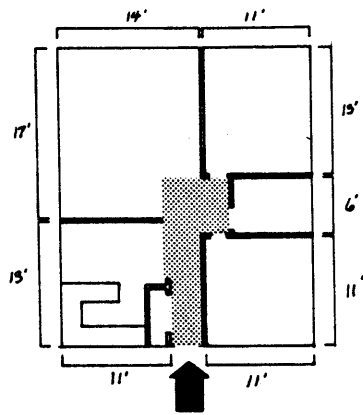

750 SQUARE FEET
25' x 30' FLAT MODULE

FIGURE 32

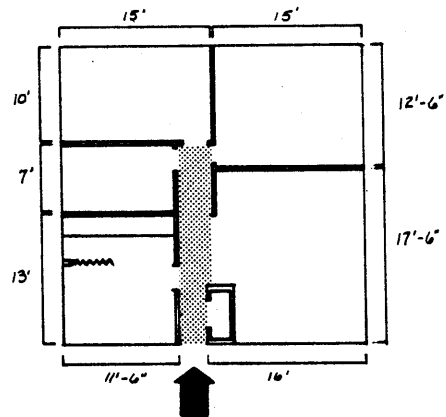
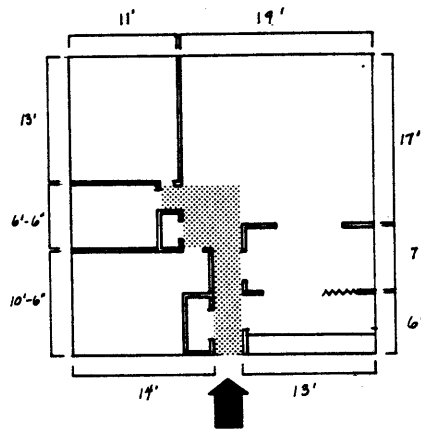
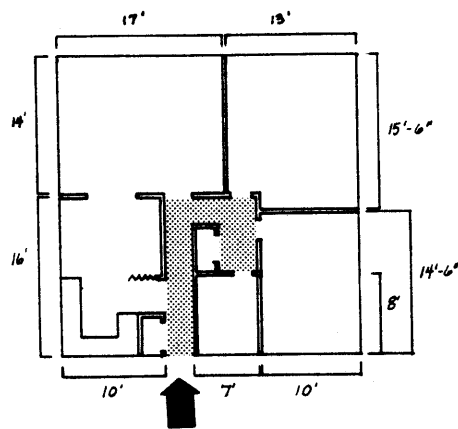

900 SQUARE FEET
 30' x 30' FLAT MODULE

FIGURE 33

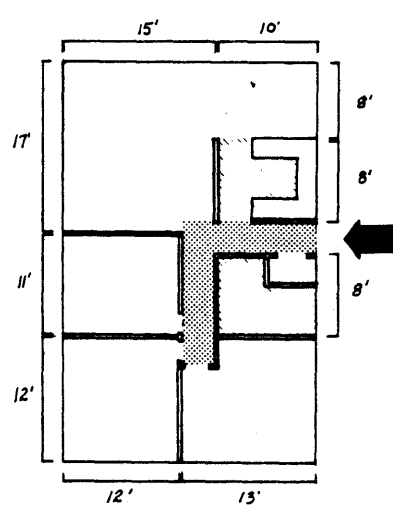
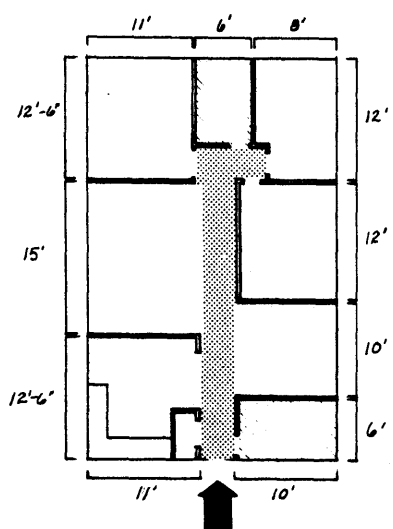

1000 SQUARE FEET
25' x 40' FLAT MODULE

FIGURE 34

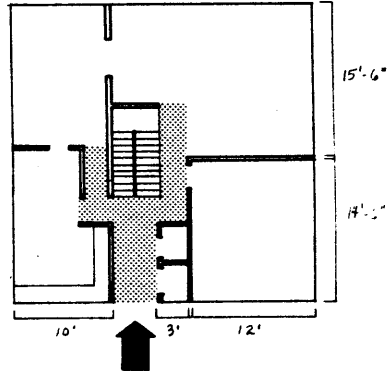
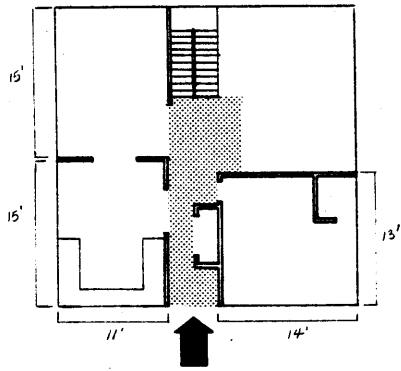
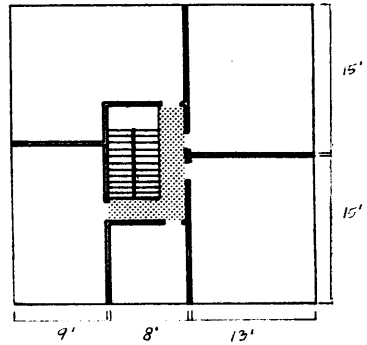
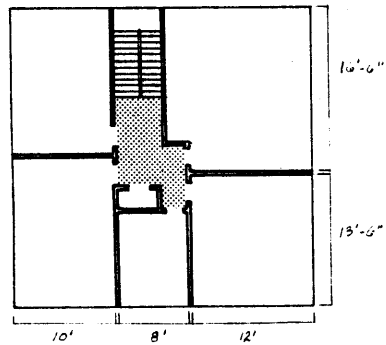

1800 SQUARE FEET
30' x 30' DUPLEX MODULE

FIGURE 35

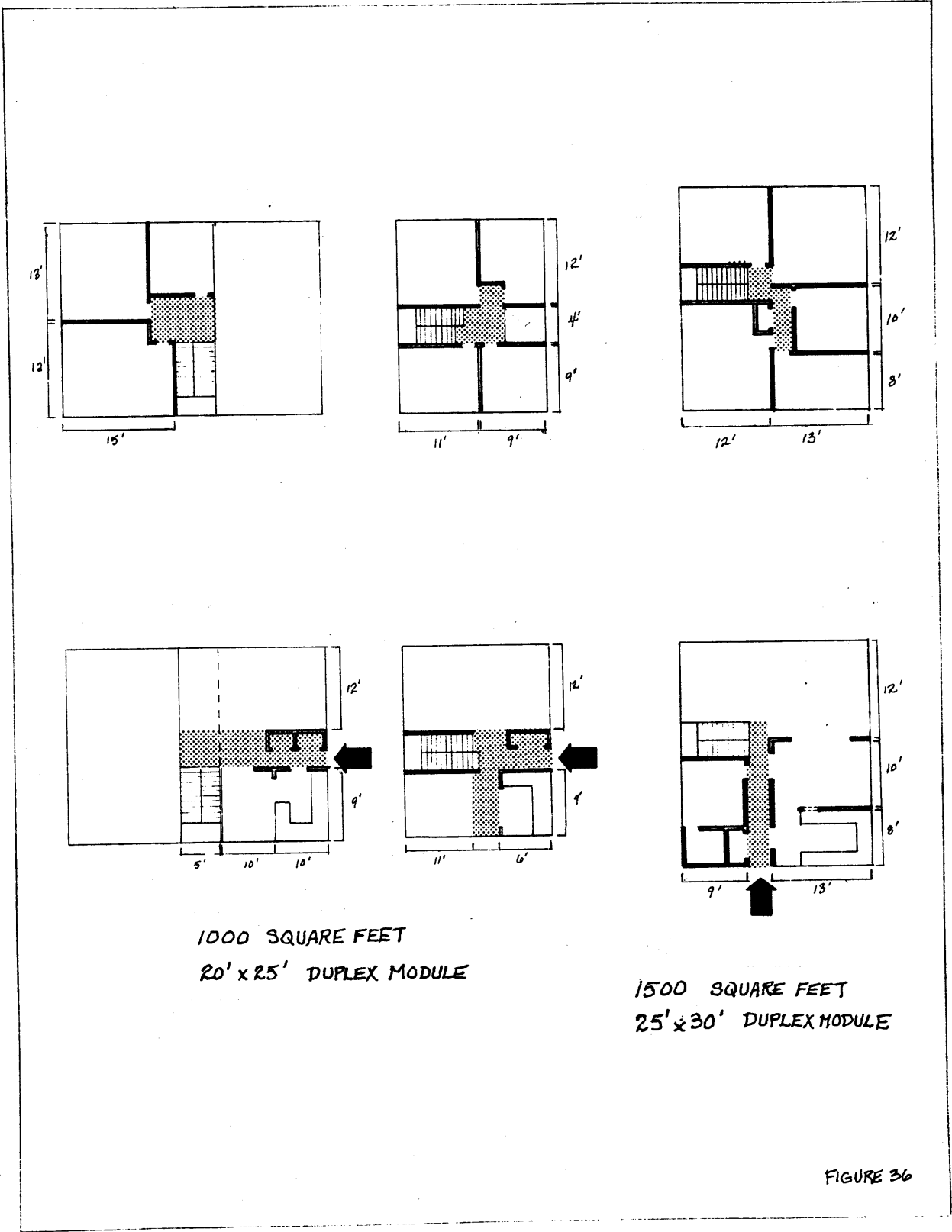

For all of the dwelling units on the site, there has been some amount of private outdoor space provided; usually more for larger family homes (Figure 39) Looking at the organizational diagram, it is clear that most of the family-type housing (3 bedrooms and up) would correspond to the site's street edges. Inside the site are stacked flats which would probably suit the needs of small families or singles; the flats on-grade would be suitable for elderly occupation. The cluster at the left is probably best for elderly, having both a view of street activity and recreation, as well as a sense of being a smaller communal entity.

The circulation, both vehicular and pedestrian is shown in Figures 37 and 38 There are 3 cul-de-sacs, allowing every home direct vehicular access: one at the front of the school, another at the right side and a third, along the left side. The third is bent to allow even more of a feeling of privacy, and in bending allows Norwood type housing to follow all the way down Fulton Street while inside the site something different is happening. The cul-de-sac at the right, leads to a pedestrian path at the side of the school. Both of these cul-de-sacs would expect little traffic, and therefore would promote a feeling of communality and ownership, with the street acting as a catalyst to neighboring.

Finally, open space is distributed in 3 parts: The main space is at the rear of the school and is at one side, a green area with places for sitting, chatting, barbequeing, and the like; further to the right is a series of hard-surfaced play areas on different levels, the largest of which is a basketball court. The others provide spaces of varying sizes, for smaller hard-surfaced uses; backboard for tennis, handball: room for jump rope, jacks, watching or just sitting.

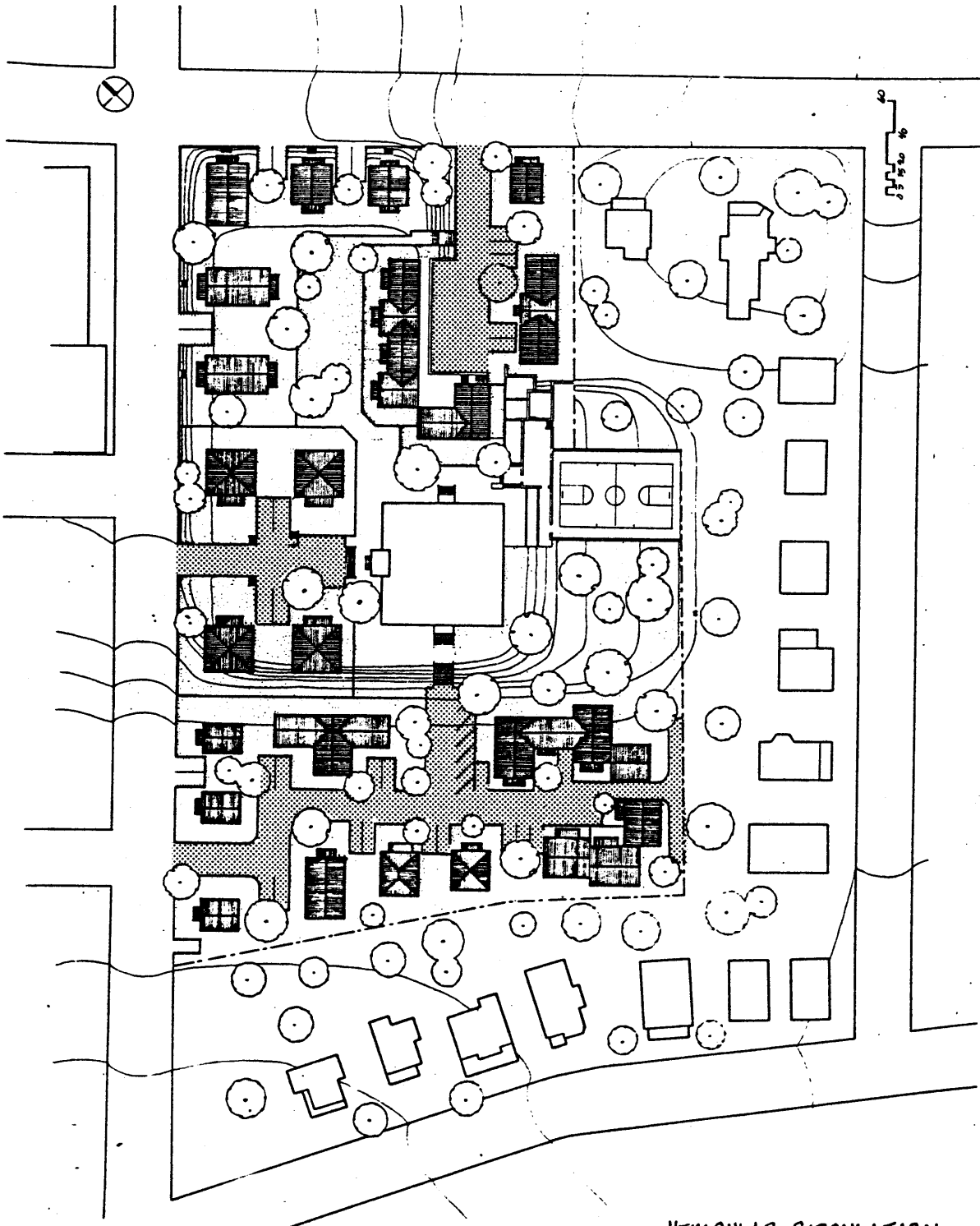

VEHICULAR CIRCULATION
FIGURE 37

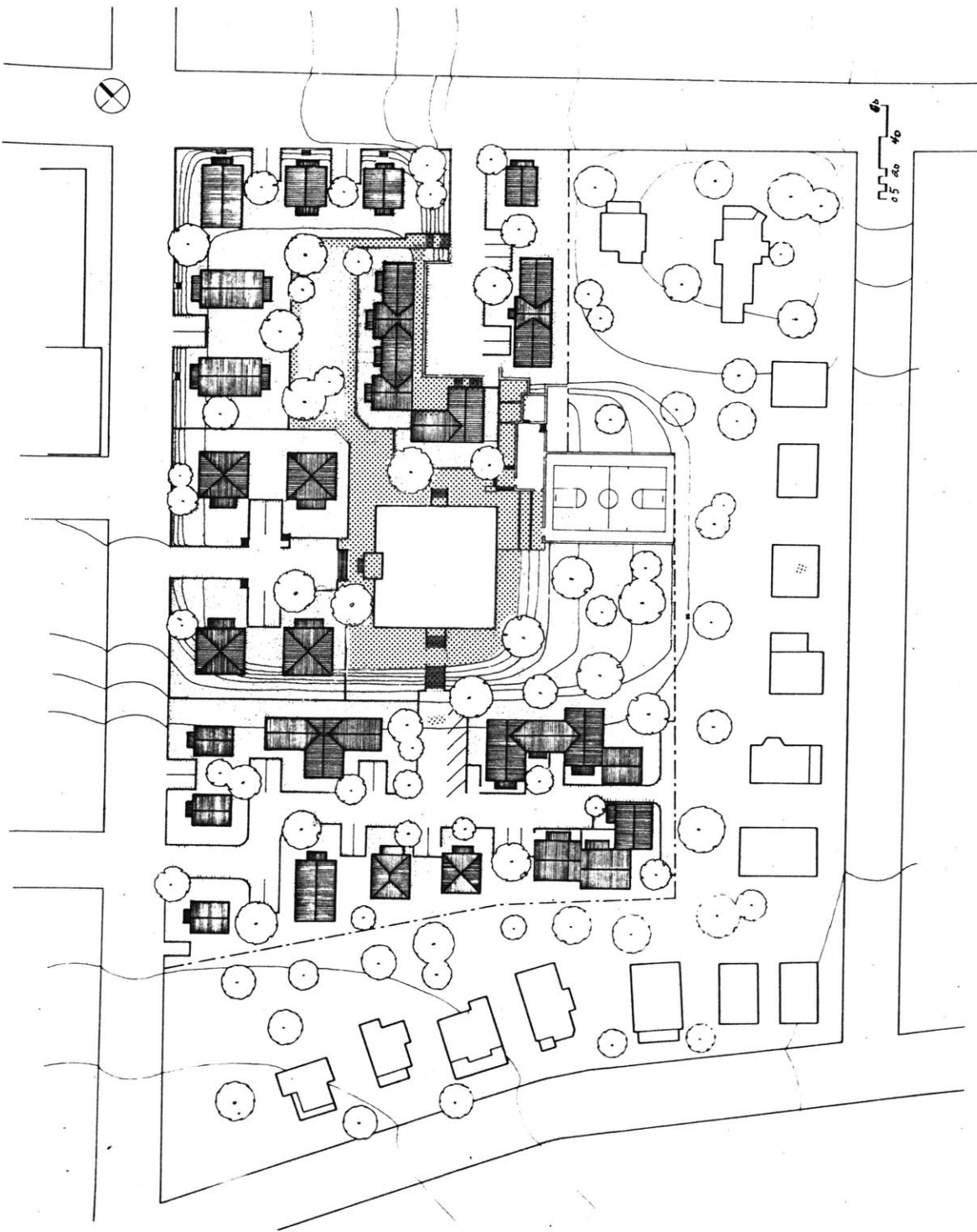

PEDESTRIAN CIRCULATION
FIGURE 38



PRIVATE OUTDOOR SPACE ■■■
VERSUS
COMMUNAL SPACE ■■■
FIGURE 39

In the front of the school is a plaza type space, acting as a buffer for the school, as well as providing pedestrian circulation to and around the school.

(The school will house some communal spaces for the residents of the site.)

To the right is an open area for quiet sitting and for tenant gardening which could add to the beautification of the site, while providing a constructive activity for bringing the residents together.

THE SCHOOL BUILDING

The recycling of the Shattuck School could be handled in several different manners. Some of the alternatives are shown in this section.

There are basically three ways to look at this problem.

- 1) Preserve everything about the existing building - only making the changes necessary to allow a large number of dwelling units to be accommodated within the existing framework of bearing walls and floors.
- 2) Nothing is sacred; tear down to the structural shell if necessary; perhaps change the facade altogether.
- 3) Preserve what exists, yet add on to it. Perhaps a new story, or wing.

With variations on each theme.

The first approach is similar to the one a normal developer might take; attacking the problem with the objective of fitting x number of units into the building while making as little change or addition as possible. Even with that concept in mind, however, there would still be some trade-offs. For instance, because the floor-to-ceiling heights are 10', 12', and 12', it would be possible to gut the building, and squeeze in 4 stories with 8' floor-to-ceiling height to gain additional apartments. Another method giving similar results would be the addition of a floor on top of what already exists.

The desired range in unit size will limit the number of units per floor, and hence the total number of units. Figure 40 shows these possibilities in plan and section. The choice between flats exclusively, and mixtures is demonstrated in Figure 41.

MAXIMUM UNIT APPROACH

PLANS FOR ALL LEVELS

8 units per floor

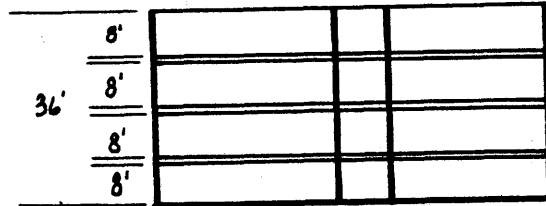
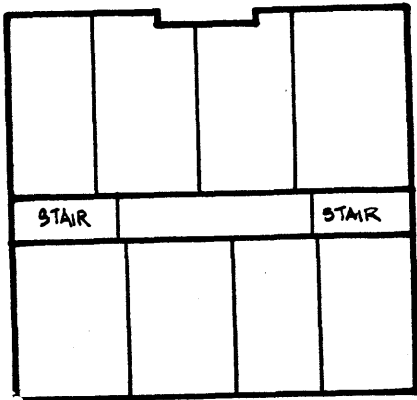

USE OF SHELL GUTTED

7 units per floor

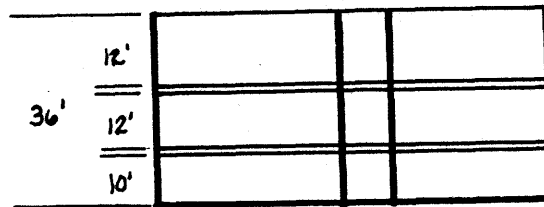
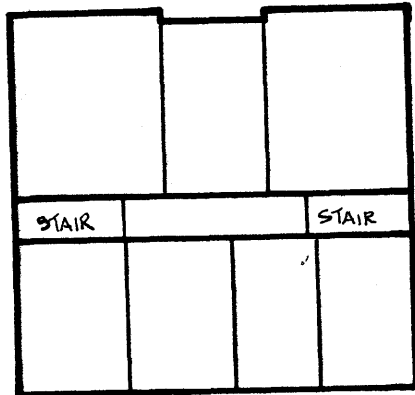

USE OF EXISTING FLOORS

6 units per floor

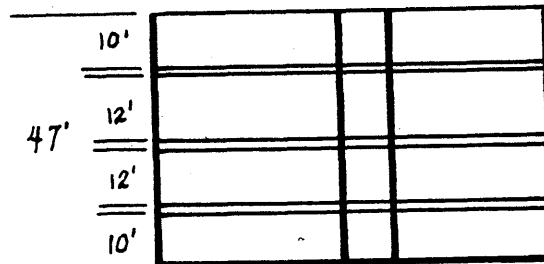
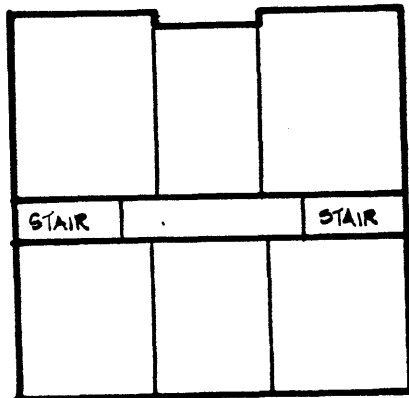

ADDITION OF ONE STORY TO EXISTING.

SCALE : 1" = 40'

➡ INDICATES ENTRY AT THE FIRST LEVEL ONLY

FIGURE 40

UNIT TYPE ALTERNATIVES

FLATS AND DUPLEXES
MIXED IN THE
GUTTED SHELL

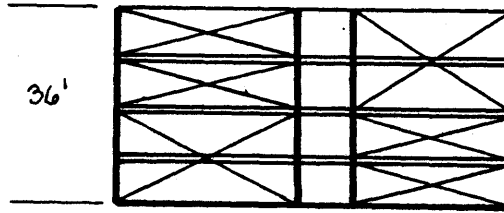

FLATS IN THE
EXISTING BUILDING

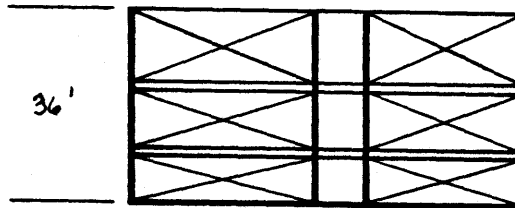

FLATS AND DUPLEXES
IN THE EXISTING BUILDING
WITH THE ADDED STORY

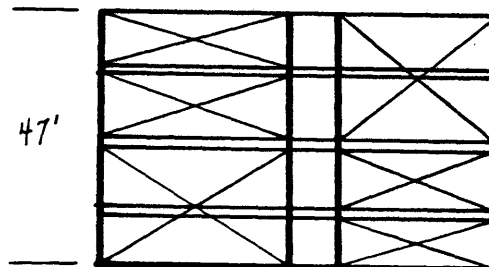

SCALE: 1" = 40'

FIGURE 41

MAXIMUM UNIT APPROACH
 SIX UNITS PER FLOOR
 (USING EXISTING STRUCTURE)

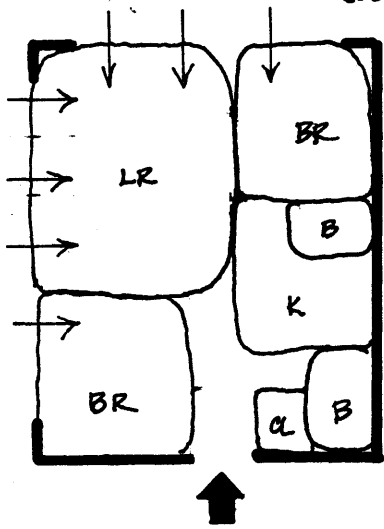

28' x 34'
 952 SQUARE FEET

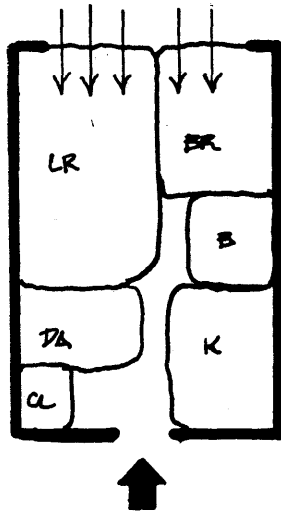

21' x 34'
 714 SQUARE FEET

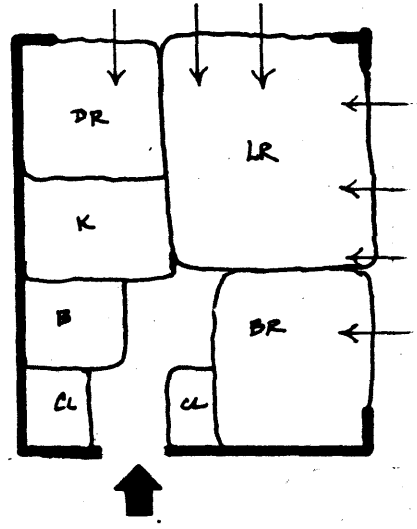

28' x 34'
 952 SQUARE FEET

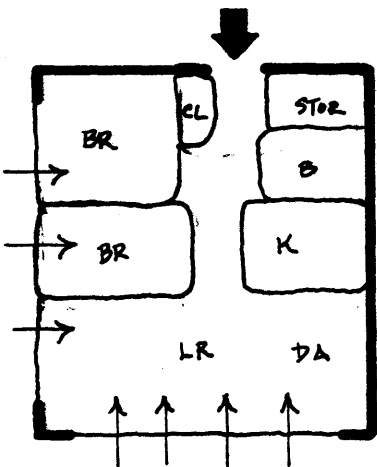

27' x 30'
 810 SQUARE FEET

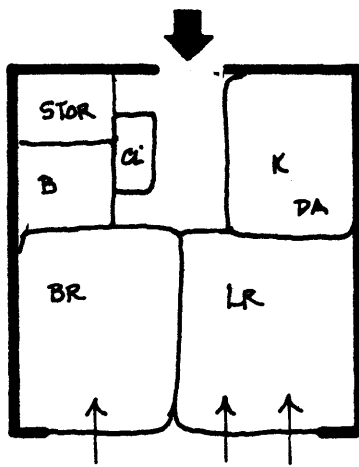

28' x 30'
 840 SQUARE FEET

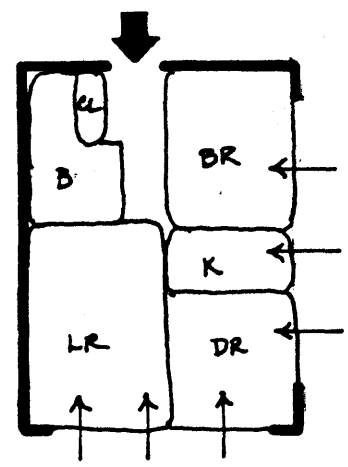

22' x 30'
 660 SQUARE FEET

→ EXISTING WINDOW
 → ENTRY

SCALE: 1" = 16'

FIGURE 43

MAXIMUM UNIT APPROACH
EIGHT UNITS PER FLOOR
(USING EXISTING STRUCTURE)

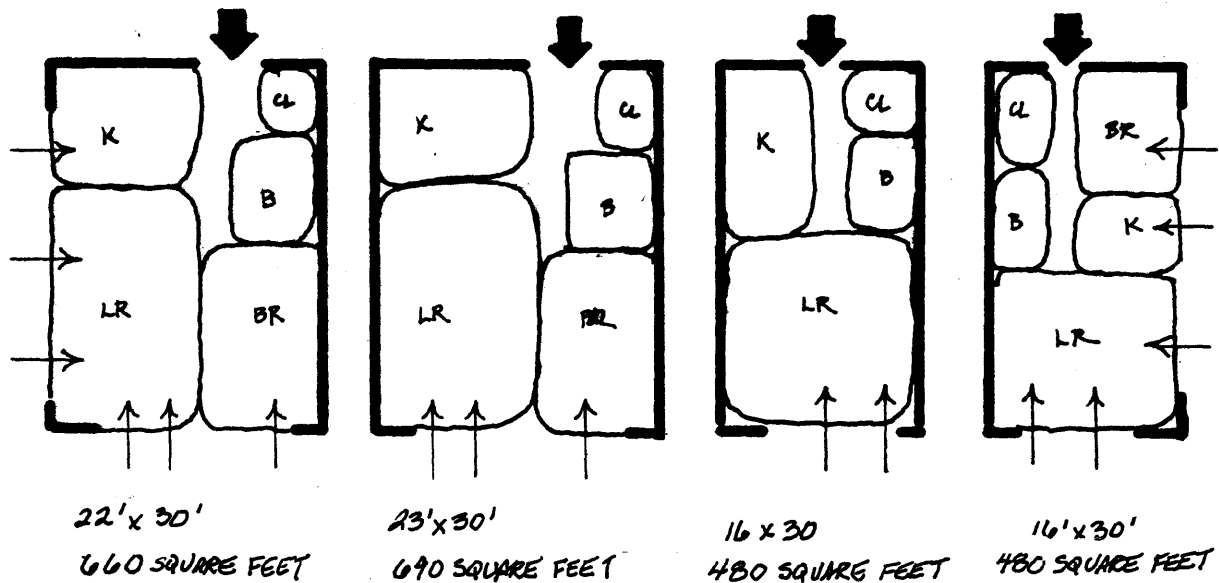
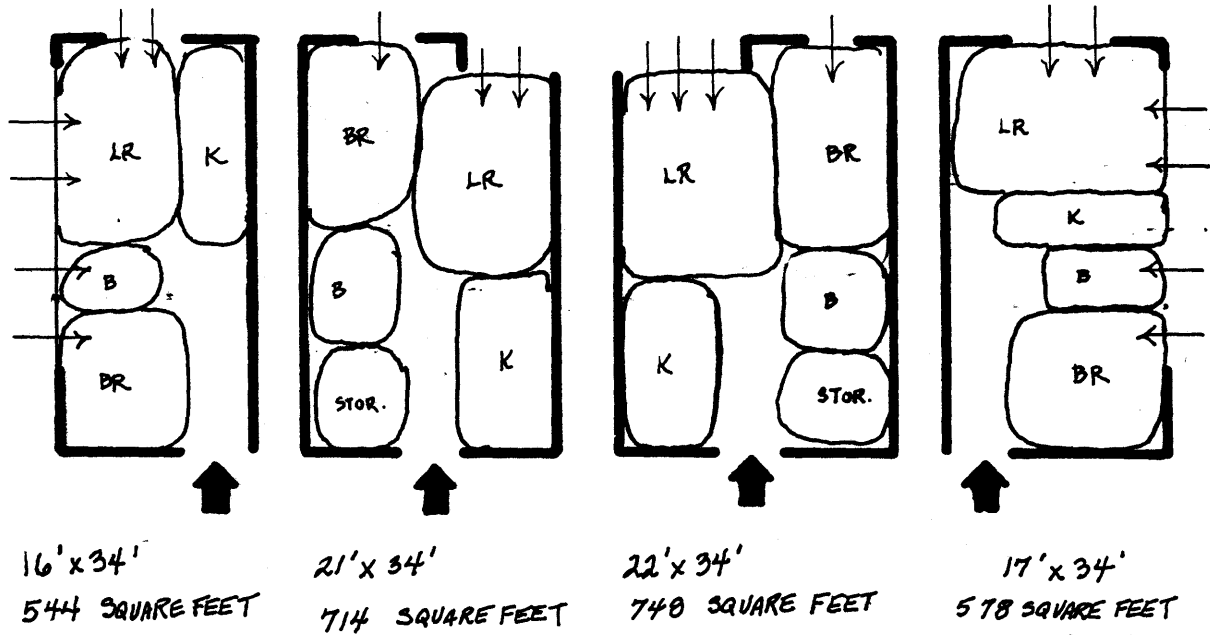

→ EXISTING WINDOW
➡ ENTRY

SCALE: 1" = 16'

FIGURE 44

Figures 45 through 47 show a progression of unit arrangements possible when varying amounts of space are subtracted from the useable floor area to serve as communal space. There are different methods of acquiring this communal space, some only involving a decrease in unit depth while others decrease the number of dwelling units possible on each floor.

There is also the option of providing private outdoor space in the form of balconies. This is achieved by creating a new building skin perhaps of glass inside the original one, and retaining the original window openings. (Figure 48). Any mixture of the above concepts is possible.

PROVIDING COMMUNAL SPACE

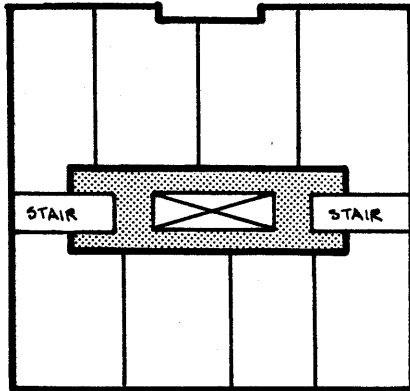

ALL LEVELS

ADDITION OF A SMALL LIGHT WELL
TO LIGHT A CENTRAL CORRIDOR.
GIVES THE COMMUNAL AREA
AN ADDED AMENITY

THE COMMUNAL AREA AND
LIGHT WELL ARE BOTH
CONTAINED WITHIN THE
EXISTING BEARING WALLS.

SCALE : 1" = 40'

FIGURE 45

PROVIDING COMMUNAL SPACE

(SHIFTING BEARING WALL LOCATION)

ADDING A LARGER LIGHT-WELL
AS WELL AS MORE
COMMUNAL AREA.

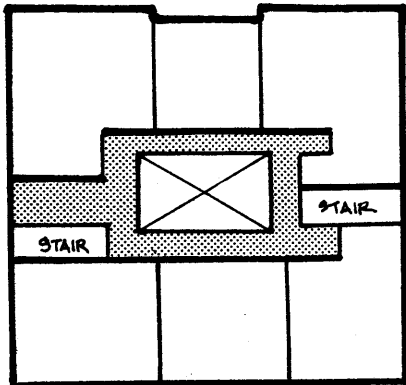

SECOND
LEVEL

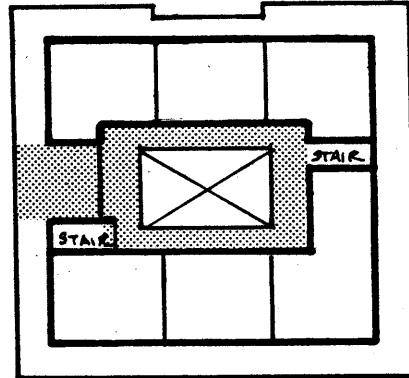

THIRD (ADDED) LEVEL

OR

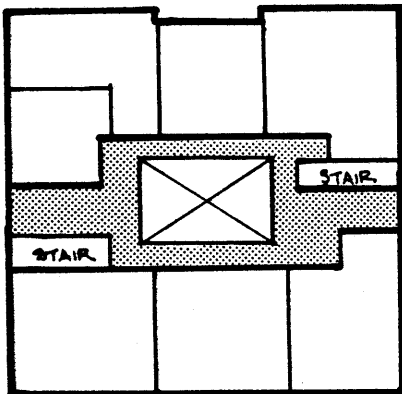

SECOND
LEVEL

INTERIOR UNITS GET
AN ADDITIONAL EXPOSURE
TO DIFFUSE LIGHT AND AIR.

AND

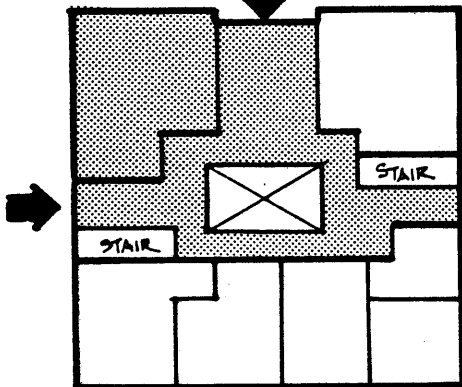

FIRST
(ENTRY)
LEVEL

WITH
BASEMENT
LEVEL

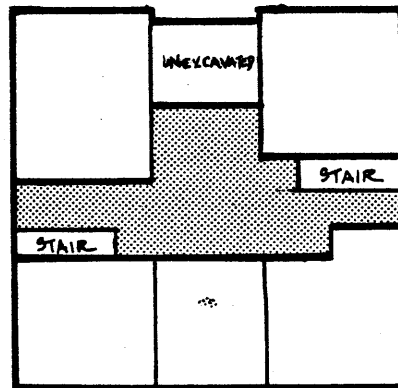

OR

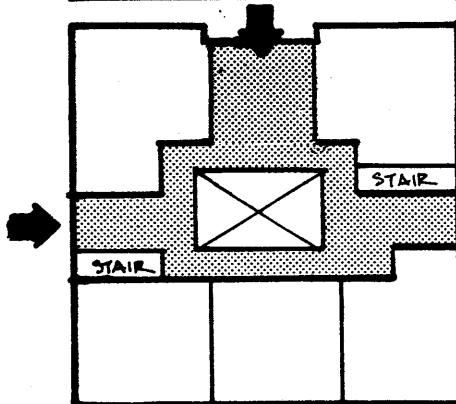

FIRST
(ENTRY)
LEVEL

WITH
BASEMENT
LEVEL

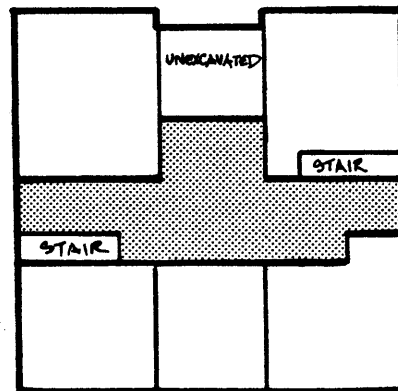

SCALE: 1" = 40'

FIGURE 46

PROVIDING COMMUNAL SPACE ON THE BUILDING'S EXTERIOR EDGE (by removing units)

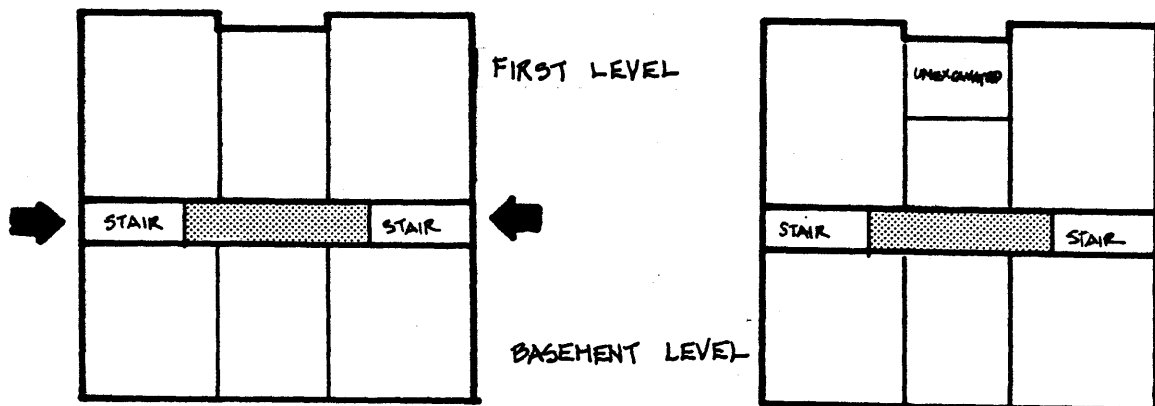
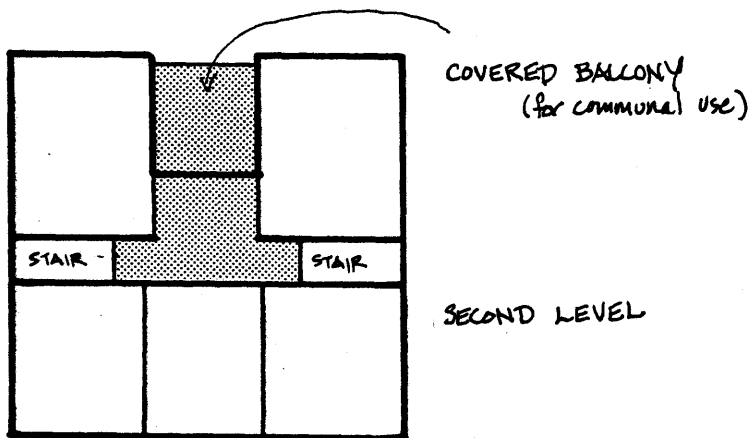
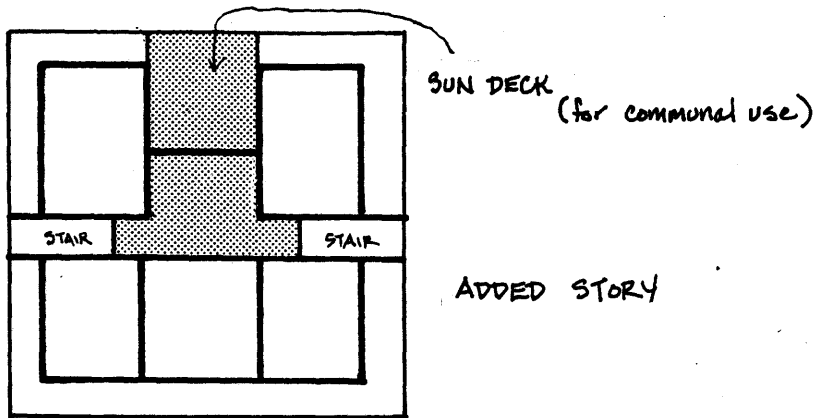

SCALE: 1" = 40'

FIGURE 47

PROVIDING EACH UNIT (Above basement level) WITH PRIVATE OUTDOOR SPACE

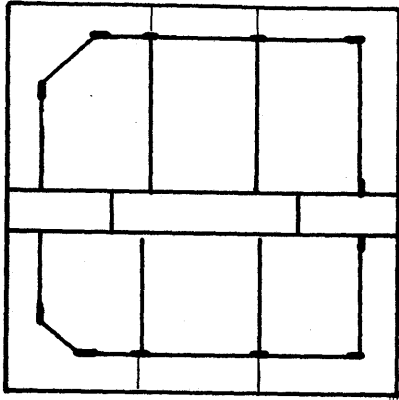

ADDED STORY

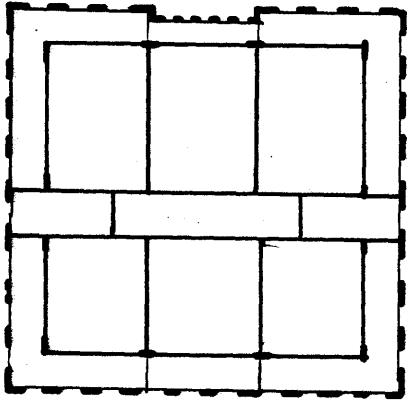

SECOND LEVEL

NEW BUILDING SKIN

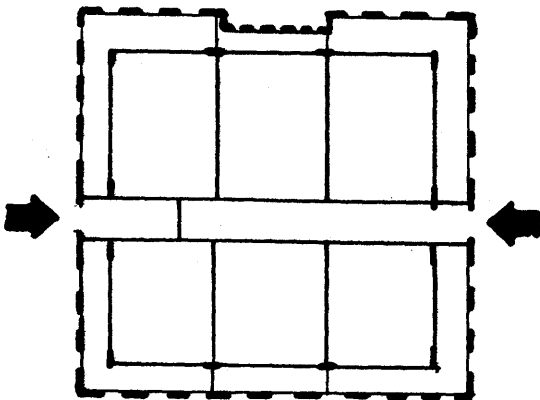

FIRST (ENTRY LEVEL)

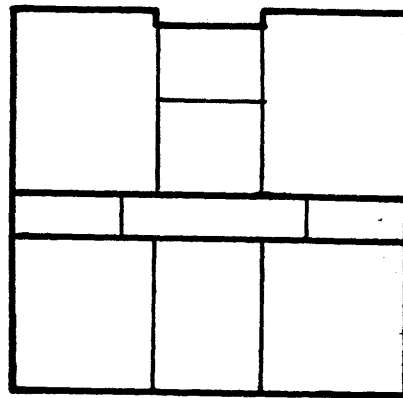

BASEMENT LEVEL

FIGURE 48

Figures 49 through 50 show other types which were generated regardless of the existing conditions, other than exposure. Different width and depths are given different possible light and air, and units were accordingly organized. With these types, it would be possible to use, perhaps the gutting approach, plug some of these in, and even combine them, to generate a whole new variety of types.

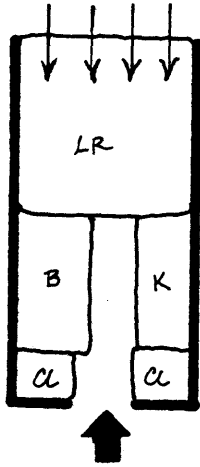

16' x 30'
480 SQUARE FEET

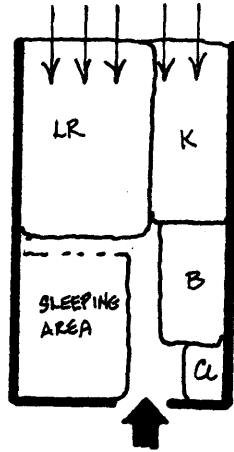

18' x 30'
540 SQUARE FEET

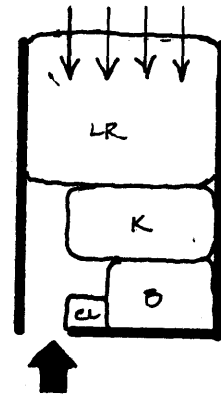

16' x 24'
384 SQUARE FEET

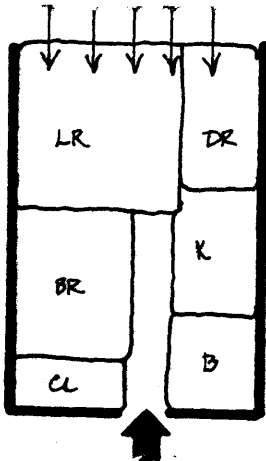

20' x 30'
600 SQUARE FEET

UNIT TYPES
GENERATED
REGARDLESS
OF EXISTING
STRUCTURE

SINGLE-SIDE
EXPOSURE
(MIDDLE UNITS)

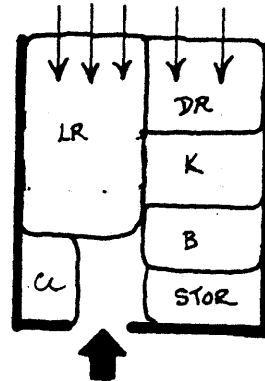

20' x 24'
480 SQUARE FEET

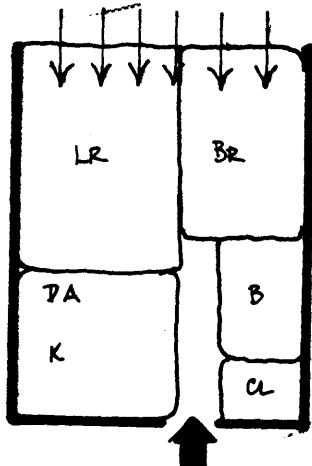

24' x 30'
720 SQUARE FEET

24' x 24'
576 SQUARE FEET

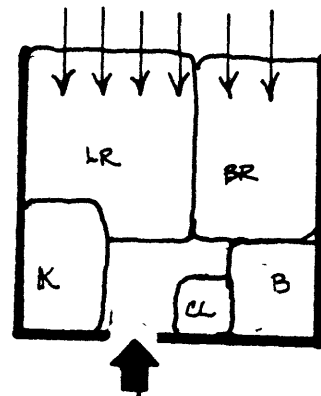

→ FACE OF EXPOSURE

➡ ENTRY

SCALE: 1" = 16'

Figure 49

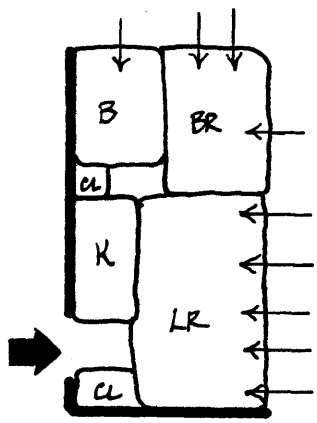

16' x 30'
480 SQUARE FEET

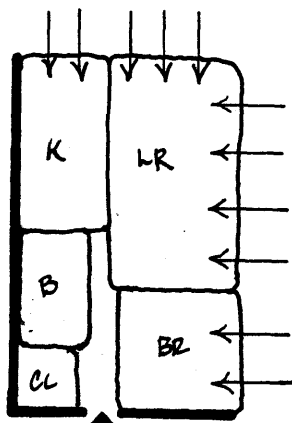

18' x 30'
540 SQUARE FEET

UNIT TYPES
GENERATED
REGARDLESS
OF EXISTING
STRUCTURE
TWO ADJACENT
SIDE EXPOSURE
(CORNER UNITS)

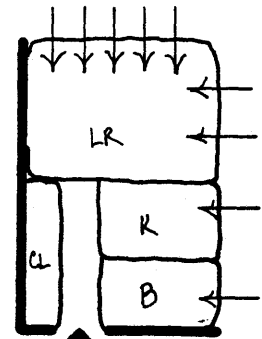

16' x 24'
384 SQUARE FEET

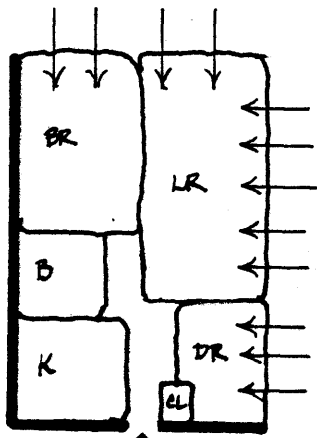

20' x 30'
600 SQUARE FEET

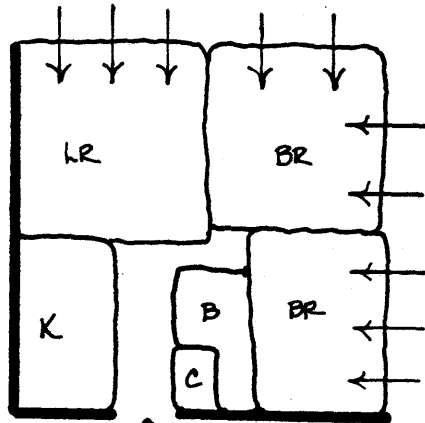

30' x 30'
900 SQUARE FEET

→ FACES OF EXPOSURE
➔ ENTRY
SCALE: 1" = 16'

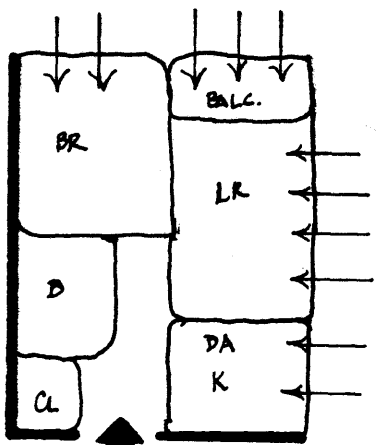

24' x 30'
720 SQUARE FEET

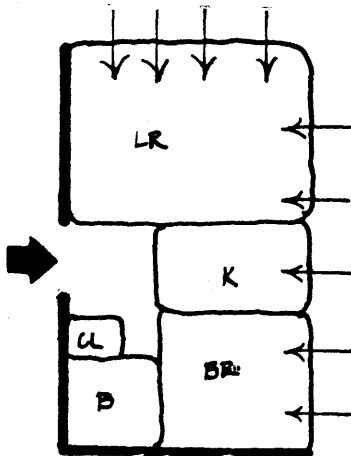

20' x 34'
680 SQUARE FEET

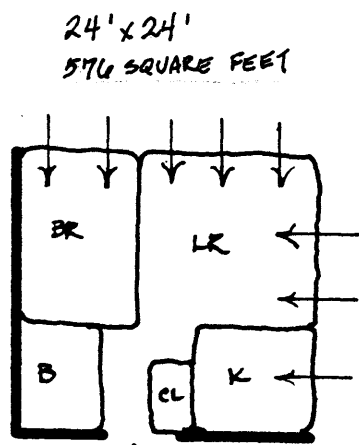

24' x 24'
576 SQUARE FEET

FIGURE 50

For an explanation of the norms and standards used in generating unit plans,
see Appendix.

CONCLUSIONS

The initial objectives for the development of this particular site were reached at the site level in terms of achieving

- the desired housing density of 15 dwelling units/acre
- a variety in housing types (detached, clusters, and row)
- private outdoor space for most dwelling units
- on site parking as specified
- variations in types of communal space
- resolution of the scale difference between school and new housing, continuity with the local housing fabric and density.

Other objectives, such as the opportunity for personalization, growth, and change, relate to the housing itself and only reached by work at a more detailed level. Specific plans, sections, and elevations should be worked out. This would be necessary in order to thoroughly resolve the integration of the school with the surrounding housing in terms of materials and forms used. Some of the interfaces, in example school/communal space, housing/communal space could be further defined.

This thesis can do more than just demonstrate the ability to develop a solution to this specific problem. It can be used as a guide for those attempting to propose the adaptive re-use of any unused school for housing purposes in other suburban towns.

BIBLIOGRAPHY

BOOKS:

- 1) Easter Hill Village: some social implications of design
Clare Cooper
Free press, New York c.1975
- 2) The Community Builders Handbook
Edt. by J. Ross McKeever
Urban Land Institute c. 1968
- 3) Remodeling Old Houses Without Destroying Their Character
George Stephen
Alfred A. Knopf, New York c. 1972
- 4) Norwood: The Centennial History of a Massachusetts Town
Bryant F. Tolles Jr.
c. 1973
- 5) Housing the Family
Great Britain Department of the Environment
Cahners Books, Boston c.1973

ARTICLES:

- 1) "Low Income Housing in the Suburbs Battle"
House and Home, Jan. 1973 p,32
- 2) "Fair Share Housing Distribution: Will it open the Suburbs
to Apartment Development ?" Listokin, David
Real Estate Law Journal, Spring 1974 p. 739
- 3) "Strategies for Integration - On Opening Up the Suburbs"
Nathan Glazer, The Public Interest Fall 1974, p.89
- 4) "Notes on Low-Rise High Density Housing"
Peter Rich, Arena, London, March 1966

APPENDIX

FOREWORD

One of the Federal Housing Administration's primary objectives is to encourage improvement in our nation's housing standards and conditions. The FHA Minimum Property Standards for Multifamily Housing represent a significant stride forward in that direction. They are designed to foster ideas and techniques that will result in better and more economical housing for American families.

FHA gratefully acknowledges the assistance rendered by many industry leaders, by other Government agencies, and by professional advisers in the preparation of these new standards.

PURPOSE

These Minimum Property Standards for Multifamily Housing are intended to encourage the provision of housing projects that meet the special needs of urban families and to protect the interests of the Federal Housing Administration in the projects.

Their chief emphasis is on features of planning, design and construction that will make for continued desirability, soundness, safety, and low maintenance and replacement cost in the housing produced.

APPLICATION

- * These standards apply to projects designed and used for normal multifamily occupancy as set forth in the various sections of the National Housing Act, both unsubsidized insured housing and subsidized housing programs including low rent public housing. They apply in the specific manner set forth in M200-3, page 25.
- * Standards for multifamily programs designed for special occupancies such as nursing homes and housing for the elderly, and guides for mobile home courts are contained in separate publications. Standards for individual 1 and 2 family dwellings and for developments of 1 and 2 family dwellings are also contained in separate publications.

These standards apply primarily to the property within its property lines. They are also concerned with improvements off the site to the extent necessary to provide streets for vehicular access, and essential services and facilities at the site.

The absence of specific minimums in any of the following standards must be interpreted within the intent of the general objectives outlined or implied, and will be so interpreted and further defined for each project by the FHA field office.

* M402-3 Minimum Room Sizes

Tables 4-1 and 4-2 set forth minimum room sizes and least dimensions for such rooms. Areas and dimensions shown are minimum and do not necessarily indicate optimum space for required living functions or placement of furniture. In a specific project, larger rooms may be necessary to assure continued market acceptance. In addition to minimum areas and least dimensions, rooms shall have an appropriate functional relationship with other rooms within the living unit and shall be suitable for their intended use.

TABLE 4-1 *

MINIMUM ROOM SIZES FOR SEPARATE ROOMS

Name of Space(1)	Minimum Area (Sq. Ft.)					Least Dimension
	LU with 0-BR	LU with 1-BR	LU with 2-BR	LU with 3-BR	LU with 4-BR	
LR	NA	160	160	170	180	12'-0"
DR	NA	100	100	110	120	8'-4"
K	NA	60	60	70	80	5'-4"
Kette(2)	30	40	NA	NA	NA	3'-6"
BR (primary)(3)	NA	120	120	120	120	9'-4"
BR (secondary)	NA	NA	80	80	80	8'-0"
Total area, BR's	NA	120	200	250	380	----
OHR(4)	NA	80	80	80	80	8'-0"

Notes:

(1) Abbreviations:

LU = Living Unit	K = Kitchen	OHR = Other Habitable Room
LR = Living Room	Kette = Kitchenette	0-BR = LU with no separate Bedroom
DR = Dining Room	NA = Not Applicable	SL = Sleeping Area
DA = Dining Area	BR = Bedroom	

(2) See M402-4.2.

(3) Primary Bedrooms shall have at least one uninterrupted wall space of at least 10 feet.

(4) Other habitable room (OHR) includes rooms such as dens, music rooms, libraries, family rooms, etc. See M402-4.5 for additional provisions.

CHAPTER IV

BUILDING PLANNING

M400 OBJECTIVE

To provide building structures and facilities for a healthful residential environment having: (1) accommodations which provide space and facilities for living and housekeeping; (2) characteristics commensurate with the anticipated rentals; (3) adequate light, ventilation, and privacy; (4) convenient public access and circulation; (5) any accessory services needed; (6) all necessary provisions for human safety.

M401 VARIATIONS

See paragraph M202.

M402 SPACE STANDARDS

M402-1 Objective

To provide each living unit with sufficient space and essential facilities, arranged and equipped for suitable living, sleeping, cooking, dining, sanitation, and storage for the use of the occupants; and to provide adequate space, conveniently located, for necessary utilities and service functions for the common use of occupants.

M402-2 General

M402-2.1 Unless otherwise noted, measurements are based upon dimensions between finish floor surface and rough ceiling surface, and between rough wall or rough partition surfaces.

M402-2.2 The area occupied by closets (or private stairs) within living units shall not be included in the determination of required room area.

* M402-2.3 The floor area of an alcove, or recess off of a room, having a least dimension less than required for the room, shall be included only if it is not more than 10 percent of the minimum room size permitted and is useful for the placement of furniture.

* M402-2.4 The projection of columns, ducts, or pipe spaces into a room shall be carefully considered in relation to probable furniture placement. Only small projections appropriately located shall be acceptable.

TABLE 4-2 *

MINIMUM ROOM SIZES FOR COMBINED SPACES

Combined Space(1)(2)	Minimum Area (Sq. Ft.)				
	LU with 0-BR	LU with 1-BR	LU with 2-BR	LU with 3-BR	LU with 4-BR
LR-DA	NA	210	210	230	250
LR-DR	NA	240	240	260	280
LR-DA-SL	250	NA	NA	NA	NA
LR-DA-K(3)	NA	270	270	300	330
LR-SL	210	NA	NA	NA	NA
K-DA(4)	100	120	120	140	160
K-DR(4)	NA	150	150	170	190
Kette-DA(4)	80	90	NA	NA	NA

Notes:

- (1) See Note (1) Table 4-1 for abbreviations of Rooms and Combined Spaces. Refer to Table 4-1 for minimum dimensions required. The minimum dimensions of a combined room shall be those of the individual single rooms involved, except for the overlap or combined use of space.
- (2) For two adjacent spaces to be considered a combined room and be eligible for the reduced areas permitted, the clear opening between the spaces shall be adequate to permit common utilization of the spaces for the different functions. In general, the horizontal opening between spaces shall be at least 8'-0", except that between kitchen and dining functions, the clear horizontal opening may be reduced to 6'-0". Spaces not providing this degree of openness shall meet minimum room sizes required for separate rooms.
- (3) A combined LR-DA-K shall comply with the following: (a) the food preparation-cooking area shall be screened from the living room sitting area; (b) the Kitchen shall be at least 60 sq. ft.; (c) the clear opening between the Kitchen and the Dining Area shall be at least 4 ft.-0 in.; and (d) the Kitchen shall be convenient to the Dining Area for serving.
- (4) These required minima apply when only eating space is in kitchen. When adequate eating space is provided elsewhere in living unit, kitchen or kitchenette minimum areas apply.