

COMPLEX MATERIALS HANDLING AND ASSEMBLY SYSTEMS
Final Report
June 1, 1976 to July 31, 1978

Volume I

EXECUTIVE SUMMARY

by

Stanley B. Gershwin
John E. Ward
Michael Athans

This research was carried out in the M. I. T. Electronic Systems Laboratory (now called the Laboratory for Information and Decision Ssystems) with support extended by National Science Foundation Grants NSF/RANN APR76-12036 and DAR78-17826.

Any opinions, findings, and conclusions or recommendations expressed in this publication are those of the authors, and do not necessarily reflect the views of the National Science Foundation.

Laboratory for Information and Decision Systems
Massachusetts Institute of Technology
Cambridge, Massachusetts 02139

ABSTRACT

This report is a summary of research performed at the Massachusetts Institute of Technology Laboratory for Information and Decision Systems under National Science Foundation Grants APR76-12036 and DAR78-17826 since July, 1976. Details are reported in Volumes II - IX, and in 18 other papers, reports and theses referred to herein.

Topics discussed include analytic modeling of transfer lines and assembly systems having unreliable elements and finite buffers, equivalence between queueing models of transfer lines and assembly networks, computational complexity, periodic scheduling, and in-process routing decisions. It also contains the beginnings of the synthesis of the techniques developed for these separate problems into an overall analytically-based methodology for design and analysis of flexible automated manufacturing systems.

Acknowledgements

The research reported here has been carried out with the generous support of the National Science Foundation under Grants APR76-12036 and DAR78-17826. We have been fortunate to have the guidance of Dr. Bernard Chern, Program Manager, and Dr. Richard Schoen, Section Head (and Acting Program Manager). In addition to the authors, many faculty members, research staff members, students, and visitors have contributed significantly to this effort. These personnel are listed in Section 6. We have also been guided by a Steering Committee whose members are listed in Section 7.

TABLE OF CONTENTS

	<u>Page</u>
ABSTRACT	i
ACKNOWLEDGEMENTS	ii
TABLE OF CONTENTS	iii
LIST OF FIGURES	vi
LIST OF TABLES	viii
PREFACE	ix
1. INTRODUCTION	1
1.1 Purposes of this Report and of the Research	1
1.2 Selection and Organization of Research Issues	1
1.3 Research Approach	3
2. RELIABILITY AND FINITE BUFFERS	7
2.1 Introduction	7
2.2 Classification of Machine and Material Models	11
2.3 Solutions	15
2.4 Numerical Results	18
2.4.1 Two-Machine Results	18
2.4.2 Three-Machine Results	35
2.5 Equivalence	44
2.6 Conclusion	48
3. ROUTING, SCHEDULING, AND COMPLEXITY THEORY	50
3.1 Introduction	50
3.2 Traveling Salesman Formulations	51
3.2.1 The Computation Complexity of Problems and the Efficiency of Algorithms	52
3.2.2 Summary of Our Research	55

TABLE OF CONTENTS (continued)

3.3	Periodic Scheduling	64
3.3.1	Introduction	64
3.3.2	Principal Definitions and Results	68
3.4	Flow Optimization	74
3.5	Summary	86
4.	SYNTHESES	90
5.	PLANT VISITS	94
5.1	Kingsbury Machine Tool Corporation, Keene, NH	95
5.2	Raytheon (Headquarters, Lexington, MA)	100
5.3	Raytheon - Marine Products, Manchester, NH	101
5.4	Raytheon Missile Systems (Andover, MA)	101
5.5	Raytheon Data Systems (Norwood, MA)	102
5.6	Xerox Corporation (Rochester, NY)	103
5.7	Sundstrand Machine Tool Corporation, Belvedere, IL	106
5.8	General Motors Technical Center, Warren, MI	107
5.9	Electronic Associates, Inc., West Long Branch, NJ	108
5.10	AMP, Inc., Harrisburg, PA	109
5.11	GTE Laboratories, Waltham, MA	111
5.12	Scott Paper Company, Philadelphia, PA	112
5.13	AMF Harley-Davidson, York, PA	113
5.14	AVCO Corporation, Lycoming Division, Williamsport, PA	114
5.15	Sundstrand Aviation Division, Rockford, IL	114
5.16	Kearney and Trecker, Milwaukee, WI	115
5.17	Pratt and Whitney Aircraft, E. Hartford, CT (also Middletown, CT)	115
5.18	Visits to MIT and Other Interactions	117

TABLE OF CONTENTS (continued)

6.	PERSONNEL	119
7.	STEERING COMMITTEE	120
8.	PROJECT DOCUMENTS	121
8.1	Reliability and Finite Buffers	121
8.1.1	Published Paper	121
8.1.2	Conference Proceedings	121
8.1.3	MIT ESL/LIDS Reports	121
8.2	Routing and Scheduling	122
8.2.1	Published Papers	122
8.2.2	Conference Proceedings	123
8.2.3	MIT ESL/LIDS Reports	123
8.3	Syntheses	123
8.4	Other Documents	124
8.4.1	Conference Proceedings	124
8.4.2	MIT ESL/LIDS Reports	124
8.4.3	Bachelor's Theses	125
9.	OTHER REFERENCES	126

LIST OF FIGURES

		PAGE
Figure 1.1	Organization of Flexible Manufacturing System Studies	4
Figure 2.1	Transfer Line.	8
Figure 2.2	Assembly Network.	8
Figure 2.3	Assembly - Disassembly Network.	9
Figure 2.4	Taxonomy of A/D Network Models.	12
Figure 2.5	Steady-state line efficiency for two-machine lines with the same first machine and different second machines -- Deterministic Processing Time Model.	20
Figure 2.6	Steady-state line efficiency plotted against the efficiency in isolation of the second machine, for two-machine lines with identical first machines. The curves are for $N = 0, 4, 10, 20, 30, 40, 50, \infty$. Deterministic Processing Time Model.	21
Figure 2.7	The probability that the first machine in a two-machine line is blocked, plotted against storage capacity -- Deterministic Processing Time Model.	22
Figure 2.8	The probability that the second machine in a two-machine line is starved, plotted against storage capacity -- Deterministic Processing Time Model.	23
Figure 2.9	Expected in-process inventory plotted against storage capacity, for two-machine lines with identical first machines -- Deterministic Processing Time Model.	25
Figure 2.10	Expected in-process inventory as a fraction of storage capacity plotted against storage capacity, for two-machine lines with identical first machines -- Deterministic Processing Time Model.	26
Figure 2.11	Effect of Machine Speed on Production Rate and Average In-Process Inventory -- Exponential Processing Time Model.	28
Figure 2.12	Effect of Machine Failure Rate on Production Rate and Average In-Process Inventory -- Exponential Processing Time Model.	29
Figure 2.13	Effect of Machine Repair Rate on Production Rate and Average In-Process Inventory -- Exponential Processing Time Model.	30
Figure 2.14	Effect of Storage Size on Production Rate and Average In-Process Inventory -- Exponential Processing Time Model.	31

LIST OF FIGURES

		PAGE
Figure 2.15	Production Rate vs. Service Rate of the First Machine -- Erlang Processing Time Model.	33
Figure 2.16	Production Rate vs. Service Rate of the Second Machine -- Erlang Processing Time Model.	33
Figure 2.17	Production rate for discrete two-machine line.	34
Figure 2.18	Performance measures plotted against storage capacity N -- Continuous Material Flow Model.	34
Figure 2.19	Average in-process inventory plotted against storage capacity N -- Continuous Model.	36
Figure 2.20	Performance measures plotted against processing speed of stage 1, μ_1 -- Continuous Model.	36
Figure 2.21	Steady-state line efficiency for a three-machine transfer line with a very efficient third machine.	38
Figure 2.22	Steady-state line efficiency for a three-machine transfer line with a very efficient first machine.	39
Figure 2.23	Steady-state line efficiency for a three-machine transfer line with identical machines.	40
Figure 2.24	Variations in the failure probability of one machine affecting line efficiency.	41
Figure 2.25	Variations in the failure probability of one machine affecting expected in-process inventory.	43
Figure 2.26	Parts and holes.	46
Figure 2.27	A Two-Buffer, Three-Machine Equivalence Class.	49
Figure 3.1	A Simple Example of a Two-Machine Flowshop Problem.	59
Figure 3.2	Optimal Schedule for Zero Buffer.	60
Figure 3.3	Optimal Schedule for Unity Buffer.	60
Figure 3.4	A Four-Machine Flexible Flowshop.	65
Figure 3.5	An Example of FFS Scheduling Problem.	72
Figure 3.6	A Two-Workstation System.	78

LIST OF FIGURES

		PAGE
Figure 3.7	Optimal Split λ as a Function of μ_1	81
Figure 3.8	Optimal Average Queue Lengths as a Function of μ_1 with $Q = 10$.	83
Figure 3.9	Optimal Production Rates as Functions of μ_1 .	84
Figure 3.10	Queue Occupation for Four-Machine Six-Piece System.	88
Figure 4.1	Small Decision Network	91
Figure 4.2	Preliminary Results from the Discrete Decision Network.	92

LIST OF TABLES

Table 2.1	Part-Hole Duality	47
Table 3.1	Monte Carlo Simulation Results	63
Table 3.2	t_{ij}^k Matrices and Operational Requirements for Six Part Example	85
Table 3.3	Optimal Strategy Assignments	87

Preface

This report is a summary of research performed at the Massachusetts Institute of Technology Laboratory for Information and Decision Systems under National Science Foundation Grants APR76-12036 and DAR78-17826. The great volume of disparate material generated in the course of these projects has resulted in a rather lengthy summary. We have therefore further summarized it as follows.

Our goal has been the complete understanding of the systems aspects of flexible manufacturing systems (FMS's). The most important features of such systems are the unreliability of processors, the finiteness of buffers, and the need for routing and scheduling. To understand systems of such complexity, we first studied two kinds of simpler models.

First we studied transfer lines, i.e. production systems which have unreliable processors and finite buffers. This study was later expanded to include assembly (and disassembly). Routing and scheduling decisions do not appear here. Various model formulations have been treated and two- and three-stage systems have been analyzed numerically. Results are presented below, in Chapter 2.

The purpose of these models has been to represent the filling and emptying of storages as a result of the failures and repairs of processors and the variations of processing times. These models will be useful to designers and purchasers of such equipment to answer such questions as: which of the machines under consideration should be used for a given processing stage? (that is, which offers the best trade off between cost, reliability, and production rate?) and where should buffers be located and how large should they be?

The concept of equivalence has been discovered. Systems of quite different layout -- such as a three-machine transfer line and an assembly network consisting of two processing machines, one assembly machine, and two buffers -- can have essentially identical behavior. In particular, their production rates are equal and their average levels of in-process inventory are related in a simple way.

Second, we have studied models of systems in which routing and scheduling decisions are required but in which stochastic effects like machine failures are not important. Two kinds of formulations were investigated: one where discrete parts are represented individually, and one where material flow is represented continuously. In the former, issues of

computational complexity are significant, and heuristic techniques based on the travelling salesman problem and on periodicity have been devised to reduce the computation. In the latter, the routing problem is formulated as a nonlinear programming problem.

We have only just begun to study the synthesis of these two problem areas. Exact solutions have been obtained for systems with a single routing decision, with two finite buffers, and with three machines which may or may not be unreliable.

1. INTRODUCTION

1.1 Purposes of this Report and of the Research

The purpose of this report is to summarize the research work done at the MIT Laboratory for Information and Decision Systems (formerly the Electronics Systems Laboratory) in the area of manufacturing and materials handling systems between June 1, 1976 and October 15, 1980 under National Science Foundation Grants APR76-12036 and DAR78-17826.

The research has been aimed at improving the low productivity in the manufacturing sector of the U.S. economy, which has been declining over the last several years. This decline has received a great deal of attention recently. Because of the need to improve productivity and because of recent advances in computer hardware, we concluded early in this period that the manufacturing area presented an opportunity for research and applications of modern control and systems theory.

Our goal has been to understand generic issues, of interest to a wide range of industries, rather than to solve specific problems of immediate benefit.

We have surveyed the literature and visited many manufacturing facilities. As a result, we have chosen to direct our efforts along certain lines and we have developed a corresponding research approach. In Section 1.2, we describe how our efforts are organized and in Section 1.3 we demonstrate the approach that we have been following in each research area. Sections 2, 3, 4, and 5 briefly describe our technical work and plant visits. In Sections 6 and 7 we list the MIT personnel involved in the project and the members of the Steering Committee. Our reports, published papers, conference proceedings and other documents are listed in Section 8. Details on all areas of research can be found in these documents.

1.2 Selection and Organization of Research Issues

The main interests and capabilities of the MIT Laboratory for Information and Decision Systems are in the areas of optimization, control, dynamic systems, network analysis, mathematical modeling, and operations

research. We have concluded that these areas are relevant to certain crucial problems in manufacturing:

- (1) The relatively little time workpieces (in batch production systems) are actually processed, compared with the great time they are in storage or being transported.
- (2) The need to find the best use of modern computer and automated materials handling equipment in manufacturing facilities, particularly flexible manufacturing systems.

There are, of course, many other pressing problems, such as the design of material processing equipment. However, our talents and resources suggest that we concentrate on systems problem areas.

This decision requires that we treat manufacturing systems as composed of discrete components which have certain properties. Other than studying these properties - such as processing time distributions, reliability behavior, and storage capacities - we do not treat the components in detail.

Our goal has been the complete understanding of systems aspects of flexible manufacturing system (FMS's). This includes the optimal operation (including routing and scheduling) as well as the optimal design (i.e., component selection to best perform a given manufacturing task) of an FMS. An FMS is a discrete part manufacturing system which is capable of automatically performing operations on a set of different parts with minimum changeover time. It has the following characteristics:

1. The production process can be represented by an automated network of flow of parts or material to be processed;
2. A variety of alternative production paths can be followed through the network, depending upon the work order to be processed or upon the availability of production units or work stations to process the work order;
3. The work orders to be processed are variable in size, nature, and economic value (batch manufacturing);
4. The production units or work stations can perform automatically a

multiplicity of functions under the control of a central computer or a local microprocessor or minicomputer;

5. Interspersed among the production units are automatic inspection or quality measuring stations.

We have not yet realized this goal. However, we have made progress in isolating important areas and studying them in great depth.

Consider Fig. 1.1, which represents the organization of our studies. The features of an FMS that we felt are most important are:

- (1) The unreliability of processing machines. Machines fail or require maintenance at random or scheduled times, and they become unavailable for a length of time which may be random or known in advance.
- (2) The finiteness of buffer storage space. Buffers fill up or become empty, and this may cause adjacent machines to be idle.
- (3) The need for routing and scheduling. The full capability of an FMS can only be realized if machines are not allowed to be idle. Since a computer controls the transportation system, and thus the routing and scheduling of parts, it should be possible to minimize idleness.

As we point out in Section 1.3, our approach has been to isolate the simplest nontrivial manifestation of these features, to isolate it, to analyze it, and to then extend the analysis. Consequently, we have divided our research into areas where:

- (1) there are unreliable machines and finite buffers, but no routing or scheduling decisions; and
- (2) routing and scheduling decisions must be made, but machines are reliable and (in most cases) buffers are infinite.

The further subdivision of these areas is discussed in later sections. It should be noted that some of our current and future work is aimed at reuniting the issues of reliability, finite buffers, and on-line operational decisions.

1.3 Research Approach

Our choice of research approach has been heavily influenced by our commitments to results of general rather than specific interest, and to long range rather than immediate payoff. It has led us to isolate

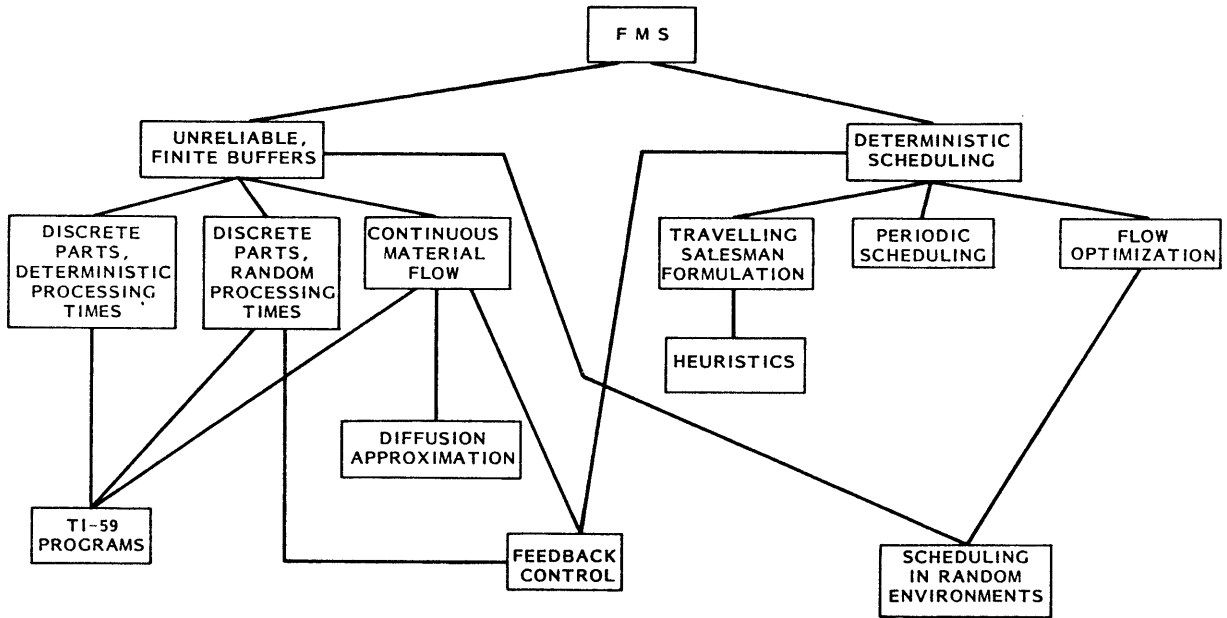

Figure 1.1 Organization of Flexible Manufacturing System Studies

issues of general importance from their particular settings, and to study them in ways that are intended to shed light on important areas, although not necessarily solve problems with immediate economic effect. For example, in studying unreliable systems with finite buffers, we have concentrated on several abstract models of a transfer line. In one model, machines fail in a particular way, and buffers have limited capacity. However, it lacks many features that appear in real transfer lines, to say nothing of FMS's. For example, machines are assumed to have the same deterministic processing time. Different production stages may not process workpieces in different cycle times. Failures are random, so that a scheduled maintenance is not considered. They are geometrically distributed and they affect machines separately. Power failures, for example, that affect the whole system are not considered. An unlimited, ever-present supply of raw material is assumed, and there is constant demand for finished goods.

All these features are important, but they would complicate an already difficult analysis. The choice of model to study is a matter of judgment, and we believe that the model we have chosen has the most qualitatively and quantitatively important features. Later study, by our group or others, can extend the model to improve its realism, but we believe that such a refinement must build on work like ours.

After an abstract model has been selected, it is analyzed mathematically. Because such models are often intractable, it may be modified so that solutions can be obtained. Part of what makes this work difficult is the need to choose a representation which is both faithful to reality (at least in some important respects) and can be studied with mathematical tools that exist or that are developed for the purpose.

The next step is to construct a simulation and compare results. This step is a substitute for testing our results in a factory setting which would be expensive. A simulation is intermediate between mathematics and reality because it can include many features of real systems which cannot be included in analytic models. Simulation can also be used to suggest the structure of the solution to a problem.

Finally, extensions are proposed and the cycle is repeated. The extensions may be intended to make the model more realistic (such as generalizing the exponential processing time transfer line model by considering Erlang processing times) or more general (such as considering assembly machines along with our transfer line models).

2. RELIABILITY AND FINITE BUFFERS

2.1 Introduction

An important attribute of the components of manufacturing systems is their reliability. Because of imperfections in design, normal wear, and random effects that would be prohibitively expensive to eliminate in advance, there are periods of time when components are not available. A component may be undergoing routine maintenance, or it may be under repair for failure. For various reasons (e.g., the difficulty of diagnosing a failure), the length of time that a component cannot perform its intended task can be modeled as a random variable.

Storages are present in many kinds of systems. They have the effect of decoupling the system so that changes from normal operating conditions at one part of the system have minimal effect on the operation of other parts of the system. While this is often useful, the precise effect of such storages on system-wide behavior is only partially understood.

We have made progress in formulating, solving, and understanding a special class of system with storage - the flow shop or transfer line. This class is illustrated in Figure 2.1. Workpieces enter the first machine and are processed. They are then stored in the first storage and proceed to the second machine and so forth. They leave the system after the k 'th machine.

Systems of this form are used in the manufacture of automobile parts (Koenigsberg, 1959). They are used in the finishing of paper products (Gordon-Clark, 1977), and in chemical processes, where the "workpieces" are chemical batches and the machines are reactors (Stover, 1956).

We have also considerably extended this analysis to treat networks involving machines that perform assembly or disassembly operations. A network performing assembly and unitary operations (where the latter are operations on single parts, such as those in Fig. 2.1) appears in Figure 2.2, while a network in which assembly, unitary, and disassembly operations exist appears in Fig. 2.3. (This network includes a machine that does both assembly and disassembly.)



Figure 2.1 Transfer Line. Squares represent machines and circles represent buffer storages.

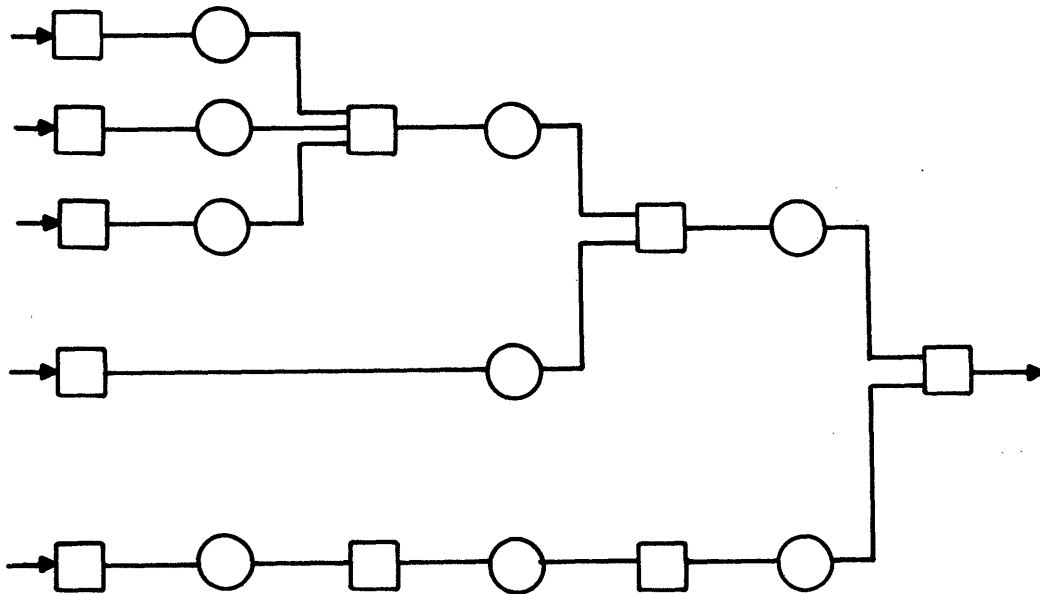

Figure 2.2 Assembly Network

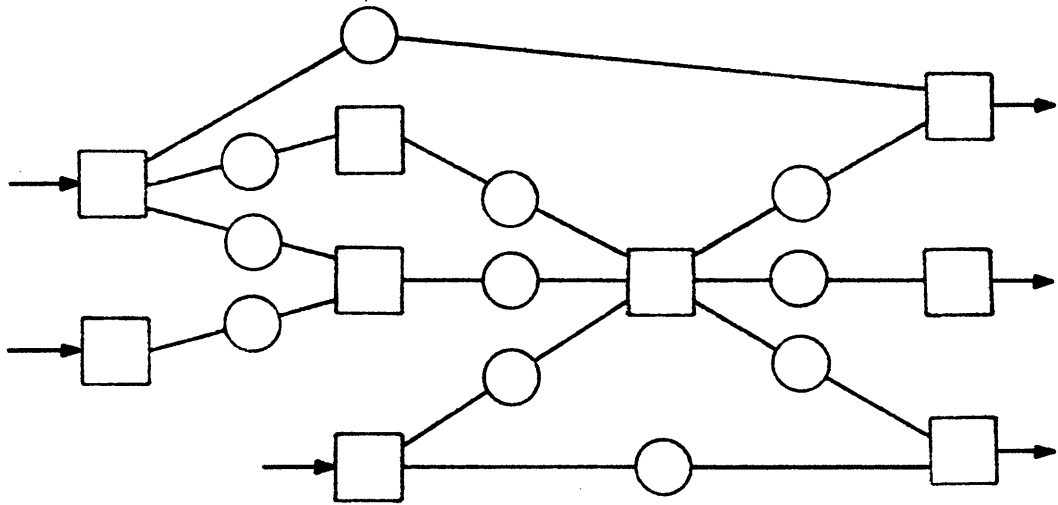

Figure 2.3 Assembly / Disassembly Network

An important feature that all these networks share, and that allows the generalization of the analysis from transfer lines to assembly/dis-assembly (A/D) networks, is the fact that there are no choices to be made. The same kind of part, or set of parts, is always presented to each machine, and the machine always does the same thing to it. Only one kind of part ever appears in each buffer.

One way in which buffers decouple systems is to isolate the effects of machine failures. When a machine downstream of a buffer fails, the buffer can provide space for partially manufactured pieces produced upstream, and thus allow upstream machines to continue operating. In the absence of such buffering, the upstream machines would have to stop, reducing overall productivity. Even when storages are present, a protracted failure can cause one or more storages to fill up. Similarly, a buffer can provide workpieces for the downstream part of the line when an upstream machine fails. Buffers also decouple systems in which the processing times are random. In such systems, a long processing time can act as a failure and, in the same way, cause other machines to be idle.

It is clear that storages that can hold more in-process inventory have a greater decoupling effect and thus provide a greater effective production rate (efficiency). However, increasing the sizes of such buffers leads to increased costs in the amount of space devoted to storage and in the inventory itself. In order to choose the best trade-off between these costs and the improvement in efficiency, it is necessary that efficiency be calculated as a function of storage size.

Formulas for efficiency in the absence of buffers and in the presence of buffers of unlimited capacity are well known (Buzacott, 1967). Also, efficiency can be calculated easily in systems with two machines and a single storage of any size (Artamonov, 1977; Buzacott, 1967a; Buzacott, 1967b; Okamura and Yamashina, 1977; Rao, 1975; Rao, 1977; Sevast'yanov, 1962). The behavior of longer systems has been formulated in many ways (Sheskin, 1976; Hildebrand, 1968) and studied by approximation (Buzacott, 1967b; Buzacott 1972; Masso and Smith, 1974) and simula-

tion (Hanifin, Liberty, and Taraman, 1975; Anderson and Moodie, 1969; Barten, 1962, Freeman, 1964; Kay, 1972; Ho et al., 1979) but no analytic technique has been successfully obtained as yet. For a more complete survey of the analytic literature, see Schick and Gershwin (1978)*, Gershwin and Schick (1980a, 1980b)* and Gershwin and Berman (1980)*.

Our studies of these systems have two purposes. First, we feel that they can be of immediate economic importance in helping to design systems. High production rates are desirable, but they can only be achieved by increasing processing speed, reliability, or storage sizes, which may be expensive. These measures may also increase the amount of in-process inventory. Our studies can help to evaluate these trade-offs, Second, they can be of long range importance because they appear to be the first to use probabilistic models and obtain exact solutions to systems with more than one finite buffer, and the first to study assembly and disassembly with queueing techniques. We anticipate that our work will lead to the analysis of more general systems, such as those with routing or scheduling choices.

2.2 Classification of Machine and Material Models

Figure 2.4 shows how the models of A/D systems we have studied are related. In all our studies, we have created Markov process representations of these systems, in which the state is given by

$$s(t) = (n_1(t), \dots, n_{k_B}(t), \alpha_1(t), \dots, \alpha_{k_M}(t)) \quad (2.1)$$

where k_B is the number of buffers, k_M is the number of machines, $n_i(t)$ is a variable representing the amount of material in buffer i , and $\alpha_j(t)$ is a binary variable representing the repair state of machine j . The storage level variables satisfy

$$0 \leq n_i(t) \leq N_i, \quad i = 1, \dots, k_B \quad (2.2)$$

where N_i is the capacity of buffer i . (We use $x_i(t)$ to represent buffer level in continuous material systems.)

The machine state variable has the following meaning:

*References marked with an asterisk are documents describing work performed at the MIT Laboratory for Information and Decision Systems under National Science Foundation Grants APR76-12036 and DAR78-17826.

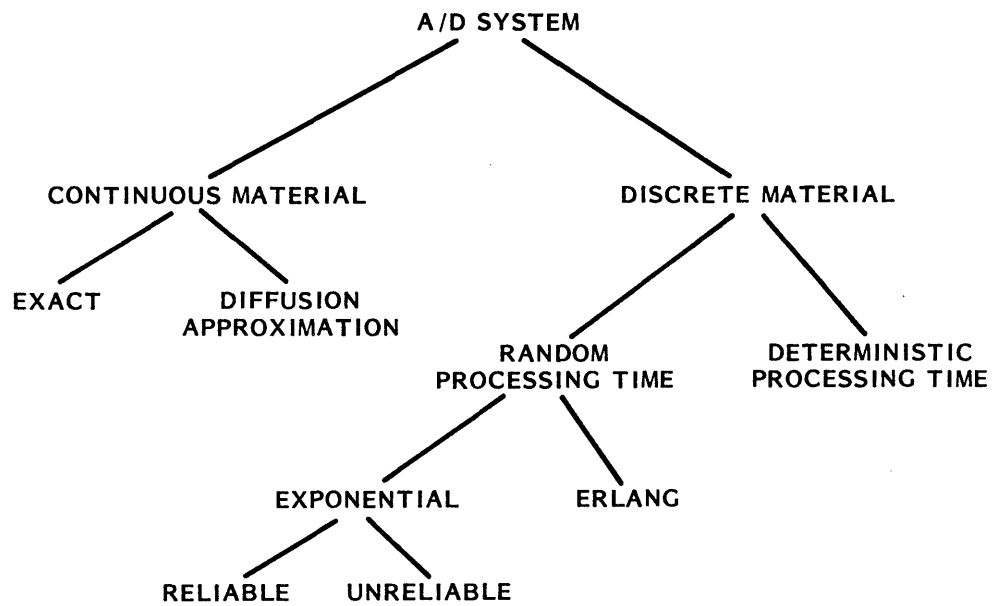

Figure 2.4 Taxonomy of Assembly/Disassembly (A/D) Models

$$\alpha_j = \begin{cases} 0 & \text{if machine } j \text{ is under repair} \\ 1 & \text{otherwise.} \end{cases} \quad j=1, \dots, k_M \quad (2.3)$$

(In one study, machines are reliable, so the $\alpha_j(t)$ variables do not appear in $s(t)$. See Ammar and Gershwin (1980a)*.)

We have sought steady state probability distributions, from which measures of performance can be calculated. These measures include the production rate and the average in-process inventory level in each buffer. Other quantities, such as the expected time until a given quantity is produced and its second moment, can be obtained by other means from a Markov process formulation.

We have presented exact solutions for models that represent the flow of continuous material in Schick and Gershwin (1978)* and Gershwin and Schick (1980b)*. These systems have two machines and a single buffer. The machines are unreliable with both failure times and repair times described by exponential probability distributions. (We refer to these systems simply as "continuous systems.") Some of our current effort is devoted to extending this analysis to larger systems.

The continuous model is characterized by three parameters for each machine and one for each buffer. The buffer parameter is its capacity N_i : the amount of material buffer i can hold. The rate at which machine i processes material is μ_i . The rate that machine i fails is p_i . That is, the probability of a failure during a time interval of length δt , which is short, is $p_i \delta t$. Note that the mean time between failures (MTBF) is then $1/p_i$. The rate of machine i repairs is r_i .

This kind of model is appropriate to water purification plants, petroleum refineries, etc., where the material to be processed actually is continuous, or where a very large number of discrete parts are being produced. The relationship between continuous systems and one model of a discrete system is analyzed in the reports cited.

Some of our research efforts are devoted to analysis and numerical solutions of three-machine continuous systems. Additional effort is devoted to alternative continuous network models and to diffusion representations, which are approximations to these models. Reports on these areas are in preparation.

Our other efforts are devoted to the analysis of systems with discrete material. That is, the material to be processed consists of

separate workpieces, each operated on individually. The major distinction is between systems with deterministic processing time and random processing time.

The former model (abbreviated as "deterministic") is appropriate when the set of pieces being treated are all the same, and where automated machines perform the operations. An example is in high volume mass production by transfer line. In the models we have considered (in Schick and Gershwin, 1978; Gershwin and Schick, 1979a, 1979b, 1980a; Gershwin and Ammar, 1979; Ammar, 1980)*, all machines take the same length of time to perform an operation; failure and repair time distributions are geometric.

The deterministic model is characterized by a set of two numbers for each machine and one for each buffer. The probability machine i fails during an operation is p_i ; the probability machine i is repaired during the time to perform an operation is r_i ; and the capacity of buffer j is N_j .

Machines with random processing times are appropriate when either

- (i) there is a mix of parts to be produced, and it is appropriate to represent the mixture as random; or
- (ii) the processors, perhaps because human operators are present, do not take a fixed length of time.

Both causes may be present. We have studied systems with exponential processing time (in Gershwin and Berman, 1978 and 1980; Gershwin and Ammar, 1979; Ammar and Gershwin, 1980)* and with the more general Erlang distribution for processing time (Gershwin and Berman, 1978; Berman, 1979)*. In all our work, failure and repair distributions are exponential, although there is at present work in progress on reliable exponential systems. We refer to these systems as exponential (reliable or unreliable if a distinction is necessary) or Erlang.

The exponential processing time model is characterized by three numbers for each machine, as well as a capacity value for each buffer. Machines are specified by μ_i , the rate at which pieces are completed while machine i is working, p_i , the rate at which machine i fails, and r_i , the rate at which repairs to machine i take place.

2.3 Solutions

Our studies began with transfer lines (Fig. 2.1) because they have the simplest possible structure. We have obtained analytic solutions, and studied qualitatively, continuous, deterministic, exponential, and Erlang two-machine transfer lines and deterministic three-machine transfer lines. In addition, as we show below, the latter applies equally well to deterministic three-machine assembly and disassembly networks. Our current work is aimed at refining our three-machine solution technique; applying it to other three-machine models, and extending it to larger systems.

To find the steady-state probability distribution of a discrete state Markov process, it is necessary to solve a set of M linear transition equations in M unknowns, where M is the number of states of the chain. In the A/D network problem, M is large, so an efficient method is required.

This problem does have a structure that can be exploited. Due to that structure, it is possible to find ℓ vectors ξ_j ($j=1, \dots, \ell$), each of which satisfies at least $M-\ell$ of the transition equations. The number of equations which are unsatisfied for at least one vector is ℓ . Consequently if the probability vector is expressed as a linear combination of these vectors

$$\underline{p} = \sum_{j=1}^{\ell} c_j \xi_j \quad (2.4)$$

then it is guaranteed to satisfy the $M-\ell$ equations each ξ_j satisfies. In order to satisfy the remaining equations, the coefficients c_j must be appropriately chosen.

To do this requires solving ℓ linear equations in ℓ unknowns. Since ℓ is much smaller than M , this is relatively easy to do. For example, in the two-machine deterministic transfer line, $M = 4(N+1)$ where N is the capacity of the buffer and $\ell=2$. In the two-machine exponential transfer line M is the same but $\ell=4$.

In the deterministic three-machine line, $M=8(N_1+1)(N_2+1)$ (where N_i is the capacity of buffer i) and $\ell=4(N_1+N_2)-10$. Clearly, when N_1 and N_2 are large, ℓ is much smaller than M . However, the ℓ equations in the ℓ unknowns c_1, \dots, c_ℓ are poorly behaved for large ℓ . It has been necessary to use extended precision (32 decimal place) arithmetic to obtain 5 decimal place precision in analyzing transfer lines with large

storages. Even though ℓ increases more slowly than M , the number of system states, the value of ℓ still limits the size of the problem that can be treated. This increase prevents the method, as currently formulated, from being usefully applied to longer line. Effort is being devoted to overcoming these limitations.

This suggests a general technique for solving large scale structured Markov chain problems. It should be considered a philosophy however, rather than a mechanical tool. Applying this technique to specific problems necessitates a great deal of analytical work. The benefit of the method is that it uses the structure of the system to substantially reduce the size of the linear system to be solved. At the same time, there is a loss of sparsity and as a result, the problem may become ill-conditioned.

A method of this type applies to continuous systems. In that context, however, the ξ vectors are functions and thus infinite dimensional. The method has worked in the two-machine context; longer lines pose technical difficulties.

In all systems, it has been necessary to classify states. This classification is presented in detail in Gershwin and Schick (1980a)*. Internal states are those in which all storages are at intermediate levels; boundary states are all others. In deterministic systems, internal states satisfy

$$2 \leq n_i \leq N_{i-2}, \quad i=1, \dots, k_B \quad (2.5)$$

In random processing time systems, internal states are those where

$$1 \leq n_i \leq N_{i-1}, \quad i=1, \dots, k_B \quad (2.6)$$

In continuous systems,

$$0 < x_i < N_i, \quad i=1, \dots, k_B \quad (2.7)$$

characterizes internal states.

In all the systems we have studied, the $M-\ell$ equations satisfied by the ξ vectors are those associated with internal states. (In continuous systems, there are an infinite number of such equations and states.) The component of the ξ vector associated with each internal state in the discrete models (other than the Erlang model) can be written

$$\xi(s,u) = \prod_{i=1}^{k_B} x_i^{n_i} \prod_{i=1}^{k_M} y_i^{\alpha_i}, \quad (2.8)$$

where s is given by (2.1) and

$$U = (x_1, \dots, x_{k_B}, y_1, \dots, y_{k_M}) \quad (2.9)$$

is a vector of parameters. In the continuous case,

$$\xi(s,U) = \exp \left[\sum_{i=1}^{k_B} \lambda_i x_i + \sum_{i=1}^{k_M} \alpha_i y_i \right] \quad (2.10)$$

where

$$U = (\lambda_1, \dots, \lambda_{k_B}, y_1, \dots, y_{k_M}) \quad (2.11)$$

is the parameter vector.

The $k_B + k_M$ parameters satisfy a set of $k_M + 1$ equations called the parametric equations. The first is of the form

$$\prod_{i=1}^{k_M} f(y_i, r_i, p_i) = 1 \quad (2.12a)$$

or

$$\sum_{i=1}^{k_M} f(y_i, r_i, p_i) = 0 \quad (2.12b)$$

The rest of the equations are of the form

$$\mu_i \frac{\prod_{j \in D(i)} x_j}{\prod_{j \in U(i)} x_j} = g(y_i, r_i, p_i), \quad i=1, \dots, k_M \quad (2.13a)$$

or

$$\mu_i \left(\sum_{j \in D(i)} \lambda_j - \sum_{j \in U(i)} \lambda_j \right) = g(y_i, r_i, p_i), \quad i=1, \dots, k_M \quad (2.13b)$$

where $D(i)$ is the set of buffers directly downstream of machine i . That is, $D(i)$ is the set of buffers that receive material from machine i . The set of buffers that send material to machine i is $U(i)$.

The significant point is that the structure of the equations is the same, even if the functions (f and g) or the equations chosen (a or b) depend on the model. The solution of one model is thus the starting point for the solutions to others. Furthermore, as long as the U parameters satisfy (2.12) - (2.13), all internal equations are satisfied, regardless of the type of the system, the number of buffers, or the size of the buffers.

The boundary states can be classified. In the three-machine case, there are transient states (whose steady state probability is zero), edge states (in which one buffer is at a boundary value and the other is internal), and corner states (in which neither buffer is internal). Larger systems have a correspondingly more involved boundary structure.

An extension to (2.8) exists so that $\xi(s,u)$ can be written for all states. While these functions can be stated compactly for edges, corner expressions tend to be complicated, at least in the deterministic case. It would be desirable to simplify these expressions because that would facilitate extensions to larger systems. Ammar (1980)* suggests some changes to the expressions of Gershwin and Schick (1979b and 1980a)* and proposes conjectures for larger systems.

2.4 Numerical Results

In this section, we present numerical results from the solutions of these models. It should be emphasized that the quantities calculated (production rates, average in-process inventories, probabilities of starvation and blockage) are all determined from the steady state probability distribution. Two-machine results are presented in Section 2.4.1; three-machine results appear in Section 2.4.2.

2.4.1 Two-Machine Results

Deterministic Processing Time Model

A set of examples from Schick and Gershwin (1978)* illustrates the effects of increasing buffer sizes and making machines more efficient. Five sets of two-machine results were calculated: the first machines of all lines were the same; the buffer sizes varied over the same range for all lines. The second machines of the lines differed; the efficiency

varied from a low value in case 1 to a high value in case 5. The system bottleneck is machine 2 in cases 1 and 2, and machine 1 in cases 4 and 5. Both machines are equally efficient in case 3. This is well illustrated by the graphs of line efficiency and probability of blocking and starving appearing in Figures 2.5 - 2.8.

The line efficiency is plotted against storage capacity for each of the five cases in Figure 2.5. In cases 3 - 5, the value of $E(\infty)$ is the same, since the least efficient machine is the first. In cases 1 - 2, on the other hand, the least efficient machine is the second one. Thus, $E(\infty)$ changes as e_2 is varied. This effect is clearly seen in Figure 2.6, where the line efficiency is plotted against the efficiency in isolation of the second machine, e_2 , for various values of storage capacity. The production rate increases with e_2 until $e_2 = e_1 = .5$, after which the first machine acts as a bottleneck and the production rate approaches an asymptote. Thus, beyond a certain point, increasing the efficiency of the second machine becomes less and less effective. This result agrees with those for the flow through a network of queues conducted by Kimemia and Gershwin (1980)*. In general, when a given attribute is limiting, the flow through the network increases linearly with that attribute; as the attribute increases, it is no longer limiting, some other attribute is, and the flow rate reaches an asymptote.

It is noteworthy that for a certain range of e_2 , it appears that providing small amounts of storage can improve the production rate as much as increasing e_2 ; for example, $e_2 = 0.67$ and no storage gives approximately the same efficiency as $e_2 = 0.6$ and $N=4$, or $e_2 = 0.5$ and $N=10$. This is significant, because improving the efficiency of a machine may involve a great deal of research and capital investment or labor costs, and may thus be more expensive than providing a small amount of buffer capacity. It is especially important that this effect is strongest when the machines have approximately the same efficiency, i.e., when the line is balanced. Since this is most often the case in industry (although deliberately unbalancing a line may at times be profitable - see Rao, 1975; Hillier and Boling, 1966), the fact that increasing buffer capacity is most effective when the line is balanced is of great importance.

Figures 2.7 and 2.8 are also revealing in that they show the dependence of forced-down times on the efficiency of the second machine and the storage capacity. The probability that the first machine is blocked ($p(N,1,0)$) is plotted against storage capacity in Figure 2.7.

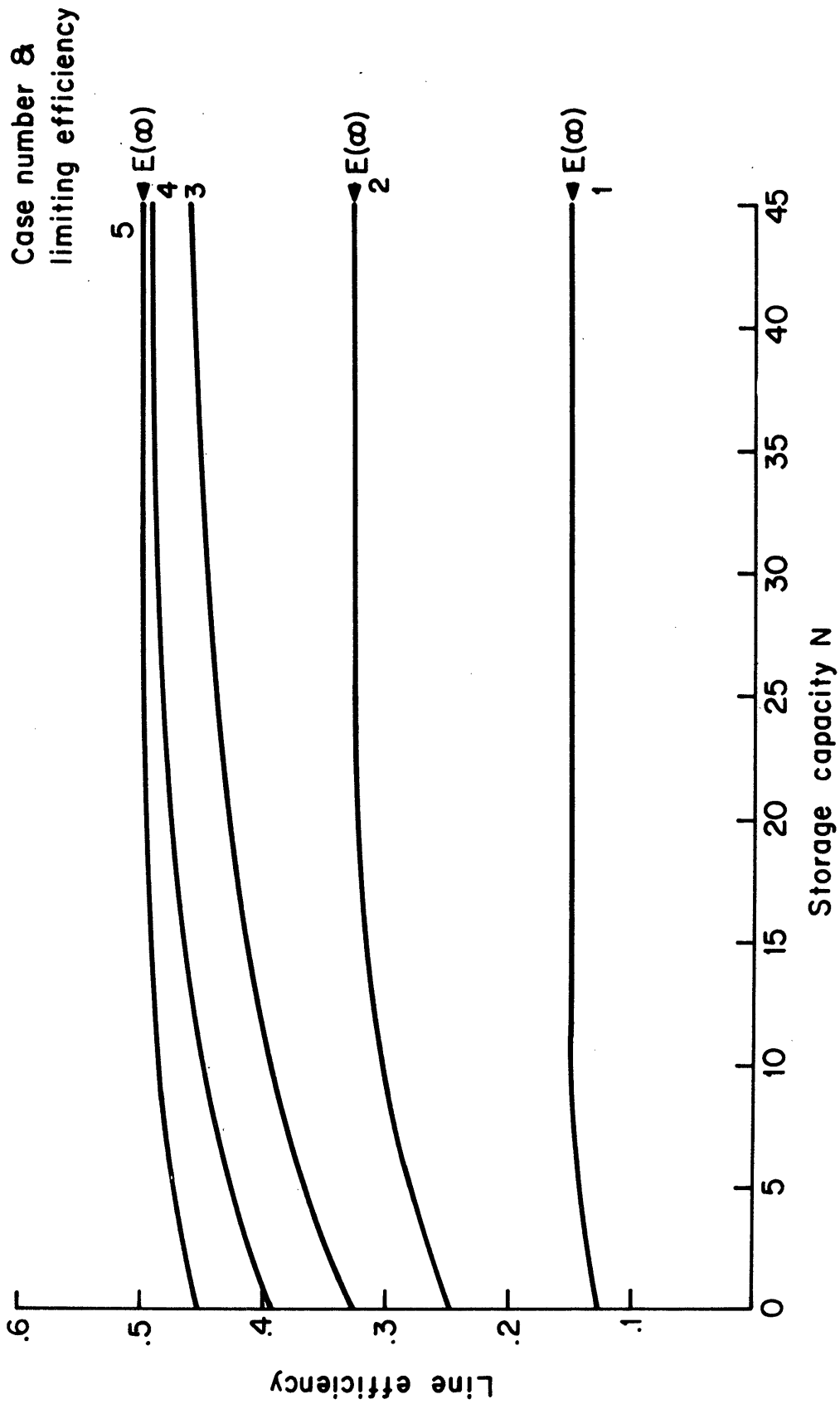

Figure 2.5 Steady-state line efficiency for two-machine lines with the same first machine and different second machines -- Deterministic Processing Time Model.

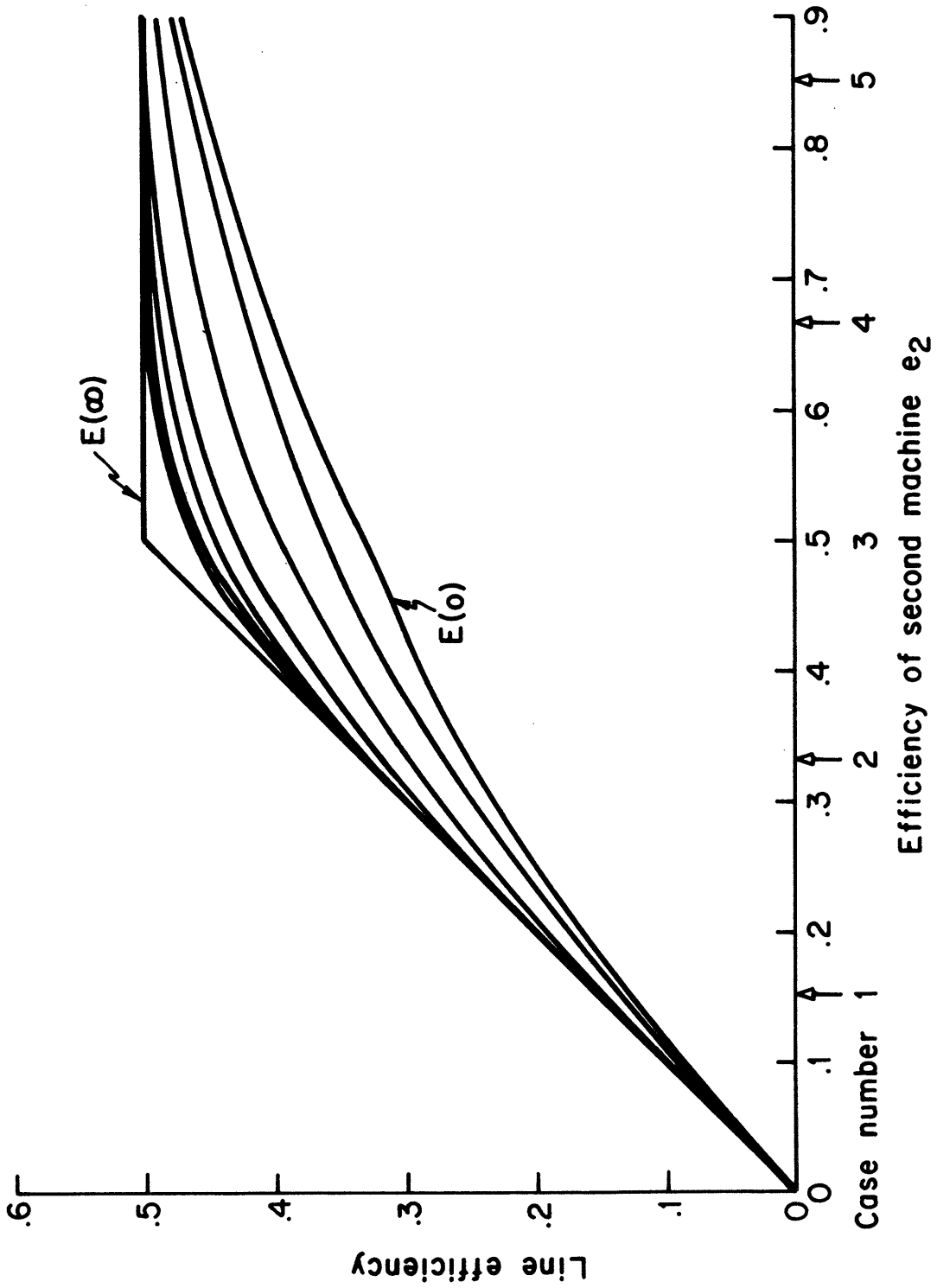

Figure 2.6 Steady-state line efficiency plotted against the efficiency in isolation of the second machine, for two-machine lines with identical first machines. The curves are for $N = 0, 4, 10, 20, 30, 40, 50, \infty$. Deterministic Processing Time Model.

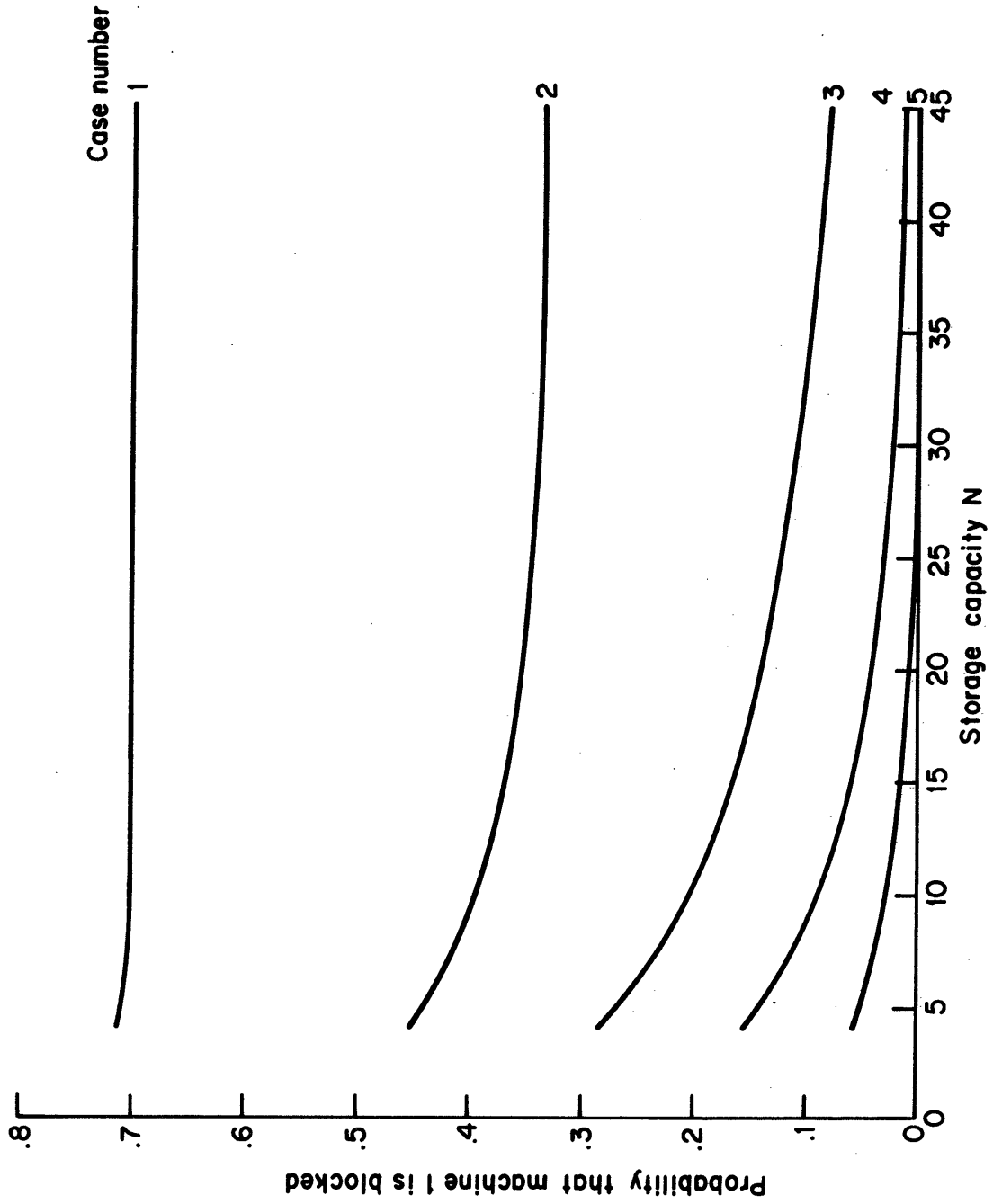

Figure 2.7 The probability that the first machine in a two-machine line is blocked, plotted against storage capacity -- Deterministic Processing Time Model.

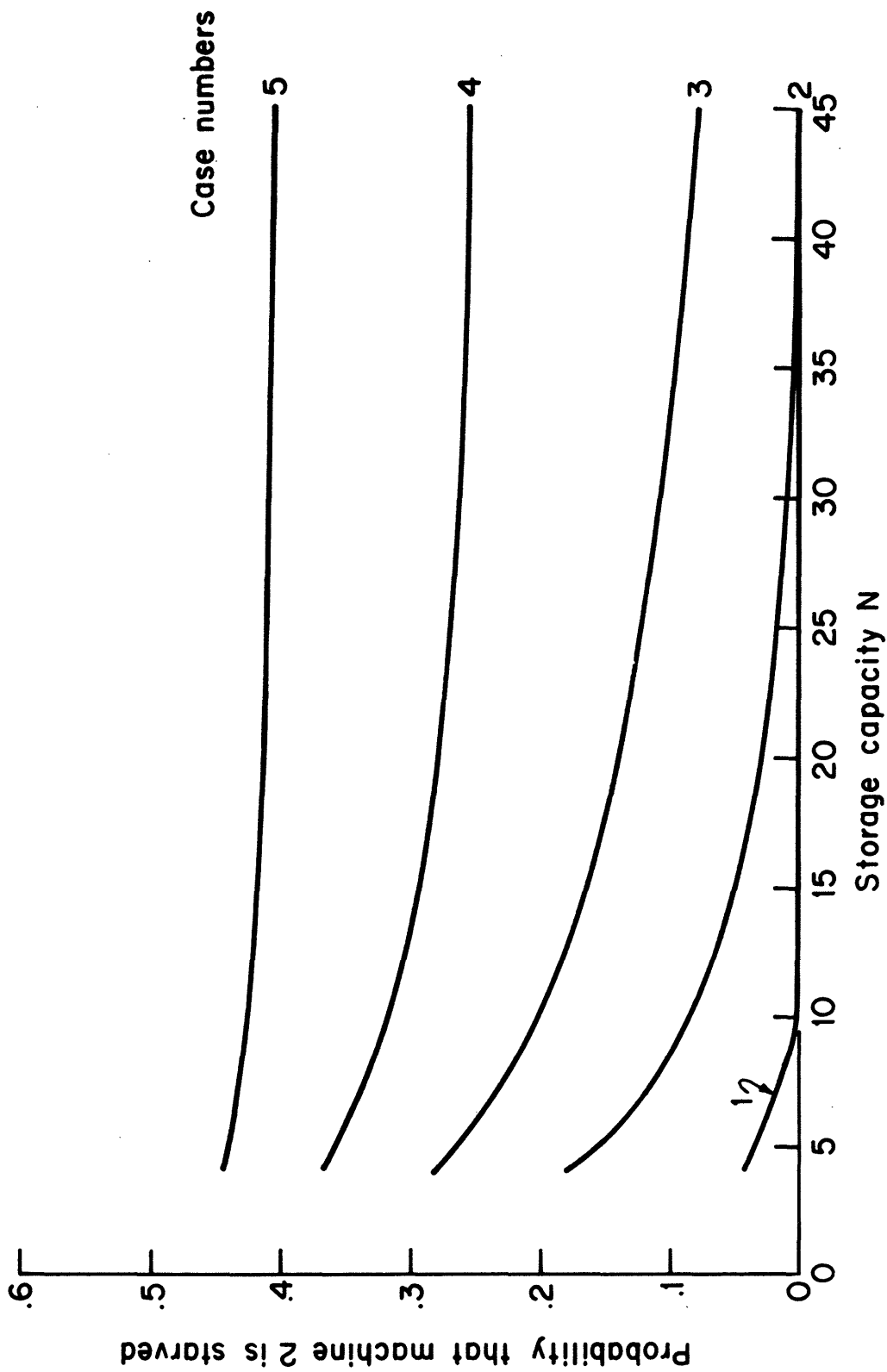

Figure 2.8 The probability that the second machine in a two-machine line is starved, plotted against storage capacity -- Deterministic Processing Time Model.

This probability approaches a positive asymptote when the second machine is least efficient, and hence the bottleneck. It approaches zero when the first machine is least efficient, so that as the storage capacity is allowed to increase without bound, the first machine is fully utilized because it is the system bottleneck. This result agrees with the findings of Secco-Suardo (1978)* and Kimemia and Gershwin (1980)*: as the speed (and thus the production rate in isolation) of a machine increases, the average size of the queue decreases.

Conversely, the probability that the second machine is starved ($p(0,0,1)$) is plotted against the storage capacity in Figure 2.8. It approaches a positive asymptote when the first machine is limiting. When the second machine is the system bottleneck, this probability approaches zero as storage increases.

The cost of providing storage may or may not increase linearly with capacity. However, the cost incurred by maintaining in-process inventory is not linear with buffer capacity because the expected in-process inventory does not increase linearly as capacity increases.

Okamura and Yamashina (1977) observe that for large enough buffer capacities, an increase in the capacity does not necessarily imply an increase in the expected number of pieces in the storage. This is illustrated by the results presented in Figures 2.9 and 2.10.

In Figure 2.9, the expected number of pieces in the storage is plotted against storage capacity. In cases 1 and 2, the first machine is more efficient than the second, and the expected in-process inventory increases with storage capacity. In case 3, the two machines have equal efficiencies, and the expected inventory increases linearly with storage capacity. In cases 4 and 5, the second machine is more efficient than the first, and the expected inventory approaches an asymptote. This is even more evident in Figure 2.10, where the expected in-process inventory as a fraction of the storage capacity is plotted against storage size. These curves approach limiting values.

Exponential Processing Time Model

Several cases were run by Gershwin and Berman (1980)* to illustrate the behavior of this model.

The graphs of the production rates ($P^{(1)}$ and $P^{(2)}$) and average in-process inventories ($n^{-(1)}$ and $n^{-(2)}$) in the first two cases are

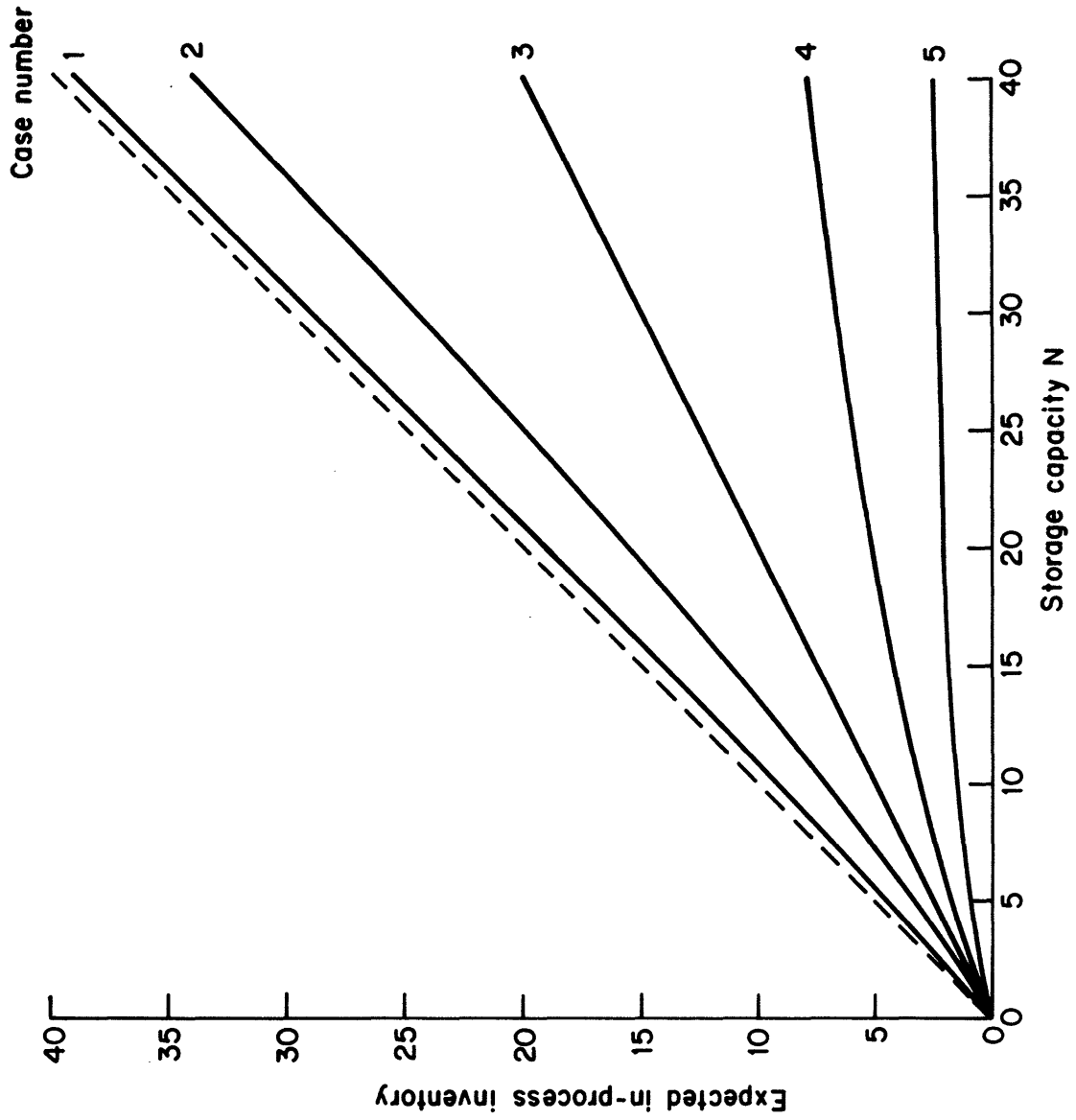

Figure 2.9 Expected in-process inventory plotted against storage capacity, for two-machine lines with identical first machines -- Deterministic Processing Time Model.

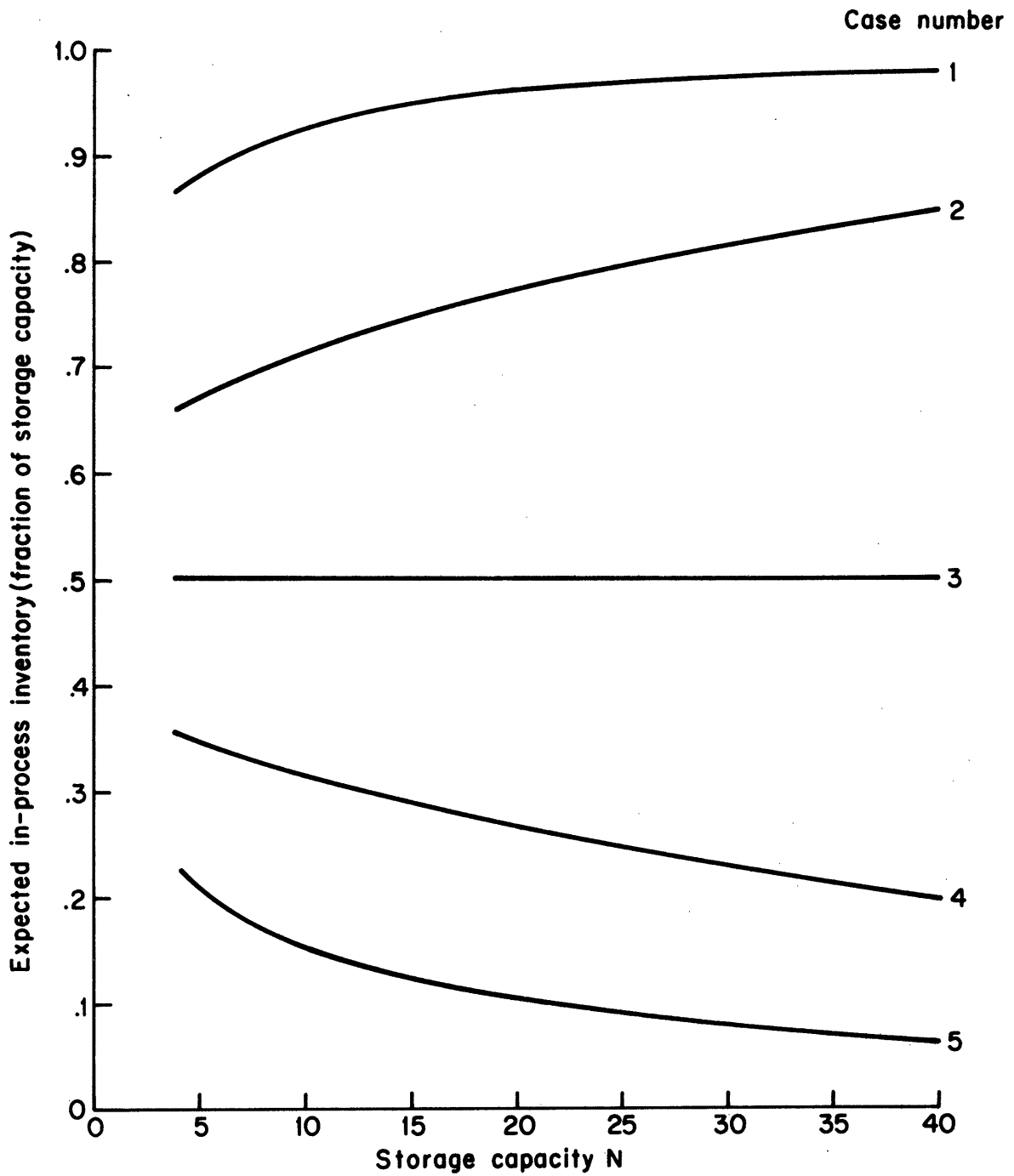

Figure 2.10 Expected in-process inventory as a fraction of storage capacity plotted against storage capacity, for two-machine lines with identical first machines -- Deterministic Processing Time Model.

plotted in Figure 2.11. The superscripts refer to case numbers.

In case 1, as μ_1 , the rate of service for machine 1, increases, the production rate P increases to a limit. That is, there is a saturation effect, and no amount of increase in the speed of machine 1 can improve the productivity of the system. Note that as the first machine is speeded up, the average amount of material in the storage, \bar{n} , increases.

In case 2, in which μ_2 is varied, the production rate for P increases. When the second machine is very fast, it frequently empties the storage. Consequently \bar{n} decreases and machine 2 is often starved.

In cases 3 and 4 failure rates p_i are varied. System production rates $P^{(3)}$ and $P^{(4)}$ and average in-process inventories are plotted in Figure 2.12.

In both cases, as p_i increases, production rate decreases. As before, when the second machine is more productive, \bar{n} is small, and when the first machine is more productive, \bar{n} is large.

Figure 2.13 contains the graphs of production rates and average in-process inventories for cases 5 and 6, in which r_1 and r_2 are varied. Again, as a machine becomes more productive (r_i increases), the system's production rate increases. As in the previous cases, when the first machine becomes more productive, \bar{n} increases and when the second becomes more productive, \bar{n} decreases.

The model's behavior, in these six cases, have the following characteristics in common: as any machine becomes more productive, due to μ_i or r_i increasing or p_i decreasing, the system's production rate increases. The average in-process inventory increases when the first machine becomes more productive, and it decreases when the second machine becomes more productive.

In Figure 2.14 are plotted the production rate and average in-process inventory for case 7, in which the storage size, N , is varied from 2 to 20.

As N increases, the production rate appears to increase to a limit. This limit seems to be the production rate in isolation of the least productive machine (ρ_1). (See Buzacott (1967b)). Note also that as $N \rightarrow \infty$, \bar{n} approaches a finite limit. This is evidently because machine 2 is the more productive stage in this system.

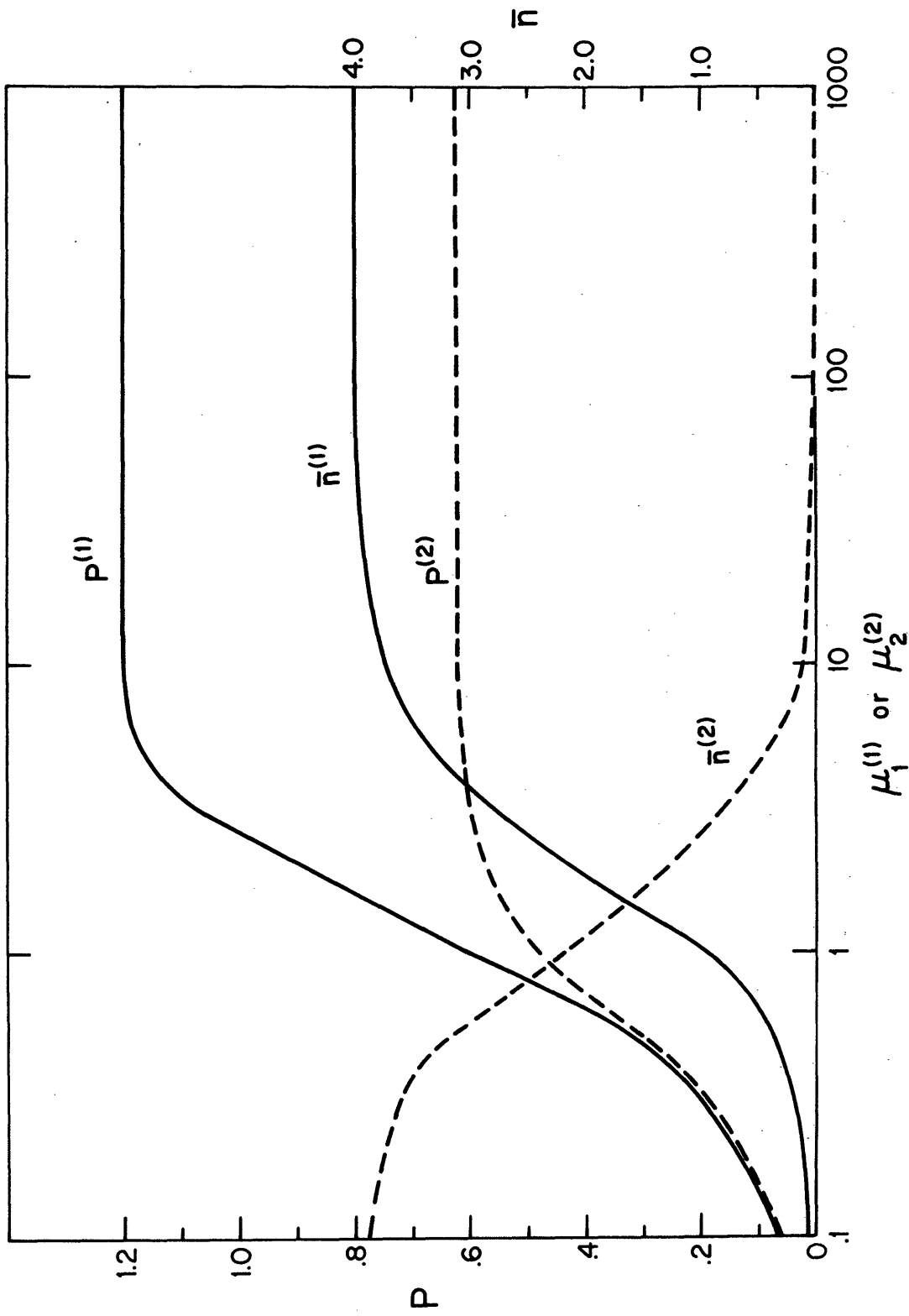

Figure 2.11 Effect of Machine Speed on Production Rate and Average In-Process Inventory --- Exponential Processing Time Model.

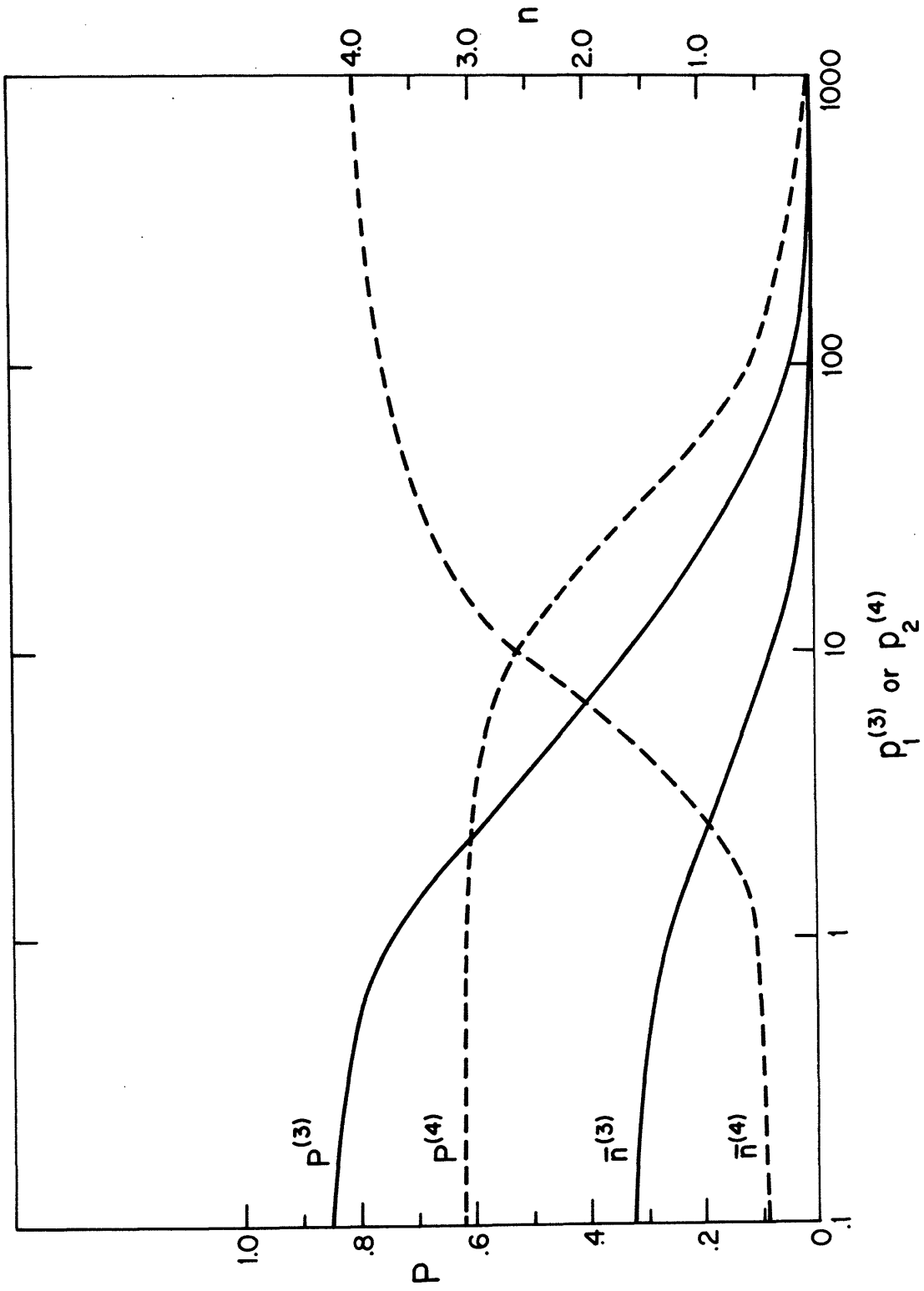

Figure 2.12 Effect of Machine Failure Rate on Production Rate and Average In-Process Inventory -- Exponential Processing Time Model.

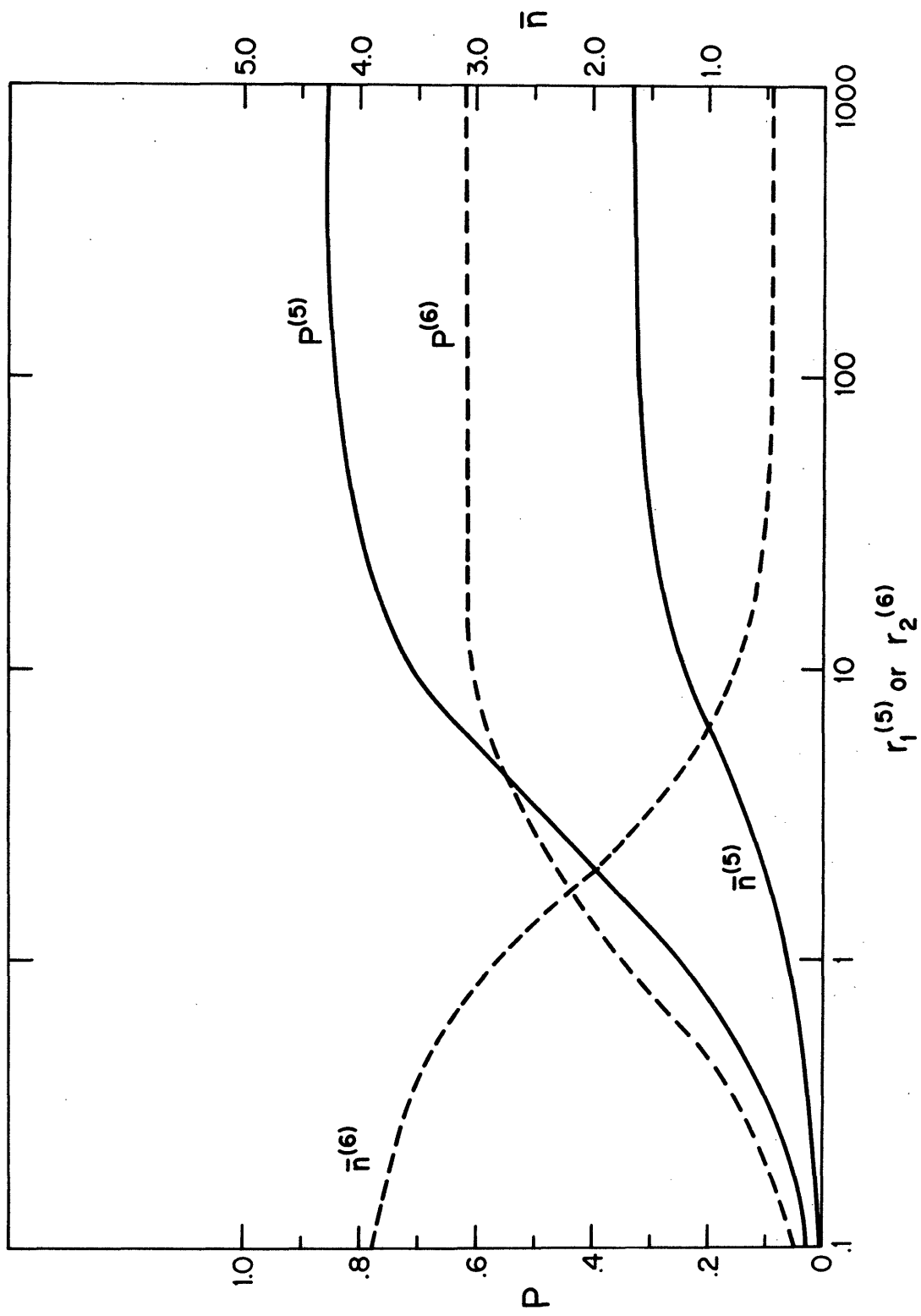

Figure 2.13 Effect of Machine Repair Rate on Production Rate and Average In-Process Inventory --- Exponential Processing Time Model.

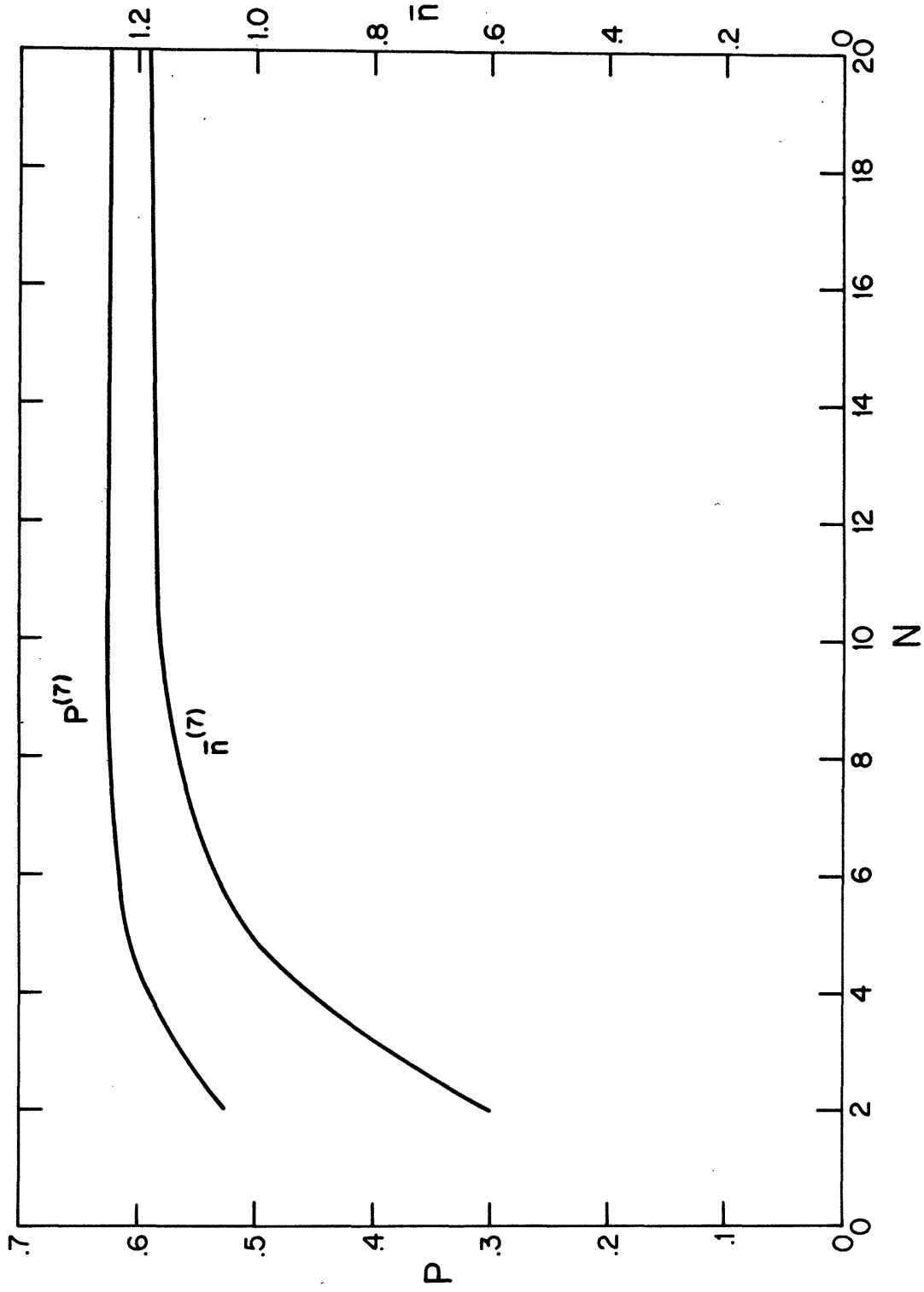

Figure 2.14 Effect of Storage Size on Production Rate and Average In-Process Inventory --
Exponential Processing Time Model

The purpose of these numerical experiments is to demonstrate that the model behaves reasonably well. Because production rate and mean in-process inventory are easy to calculate, the model should be a useful tool for manufacturing engineers to use in evaluating alternative configurations of two-stage transfer lines.

Erlang Processing Time Model

A set of numerical experiments were displayed by Berman (1979)*. This case is a generalization of the exponential processing time model. Figures 2.15 and 2.16 show how the production rate and average in-process inventory vary with the speed of the first machine. This behavior is similar to the other graphs, but it is interesting to see that these curves are slightly s-shaped.

The δ -transformation

The δ -transformation was introduced in Schick and Gershwin (1978)* and Gershwin and Schick (1980)* for computing the production rate of some discrete systems with large storage capacities. The algorithm is based on the observation that the production rate is nearly preserved by the δ -transformation; thus, the production rate of a deterministic processing time system with a large storage capacity may be approximated by that of a system with a small storage capacity, if the systems' parameters are related in a certain way. The advantage of this approach stems from the fact that the computational effort required to compute the production rate of a discrete system (as well as the memory requirements, for production lines consisting of more than 2 stages) increases with its storage capacity.

Figure 2.17 illustrates the behavior of the production rate of a deterministic processing time system as $\delta \rightarrow 0$ such that $1/\delta$ is an integer. It is noteworthy that the limit of the discrete production rate as $\delta \rightarrow 0$ is the production rate of the continuous system. Furthermore, the range of the production rate over $0 \leq \delta \leq 1$ varies by only about 1.7%, which would be a reasonable approximation for some applications.

Continuous Model

The production rates, forced down times (expected fractions of time during which the first stage is blocked or the second is starved) and average in-process inventories of some continuous systems are plotted in

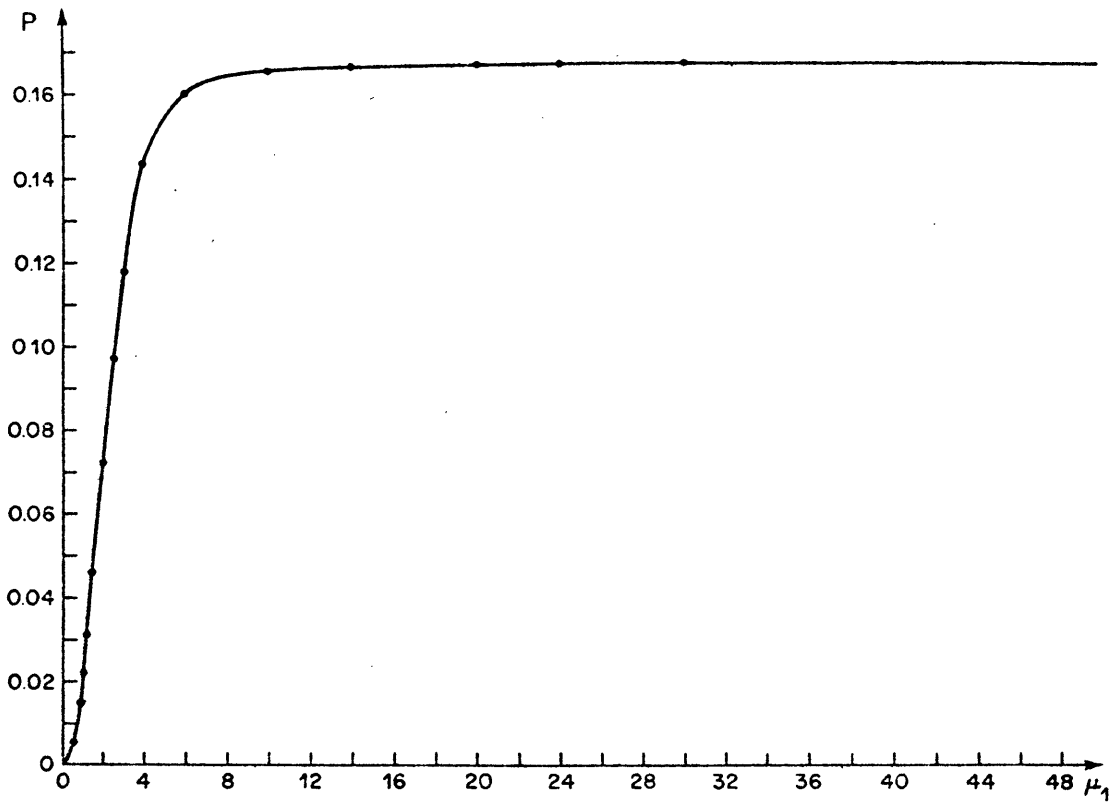

Figure 2.15 Production Rate vs. Service Rate of the First Machine -- Erlang Processing Time Model

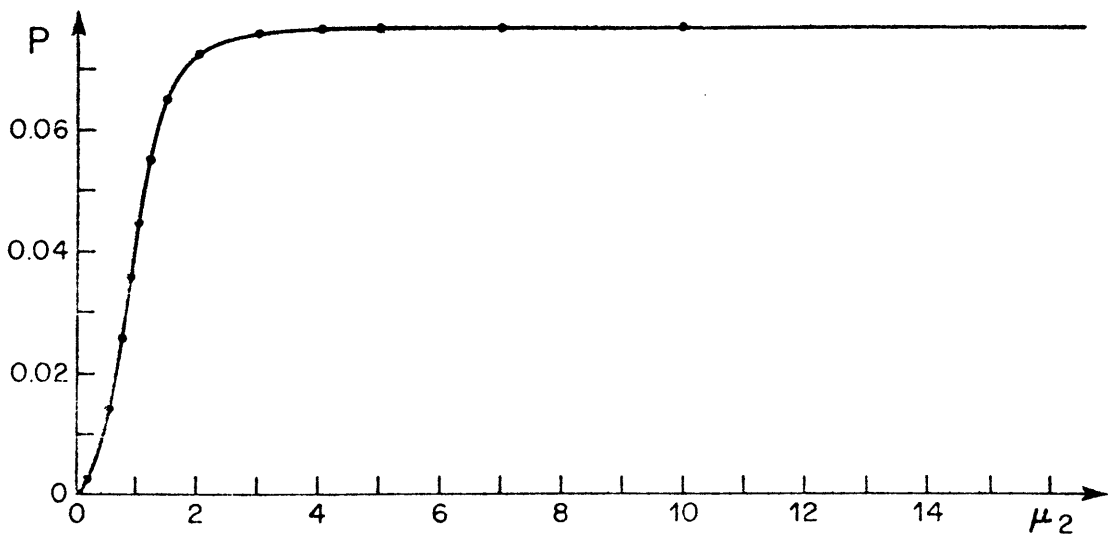

Figure 2.16 Production Rate vs. Service Rate of the Second Machine -- Erlang Processing Time Model

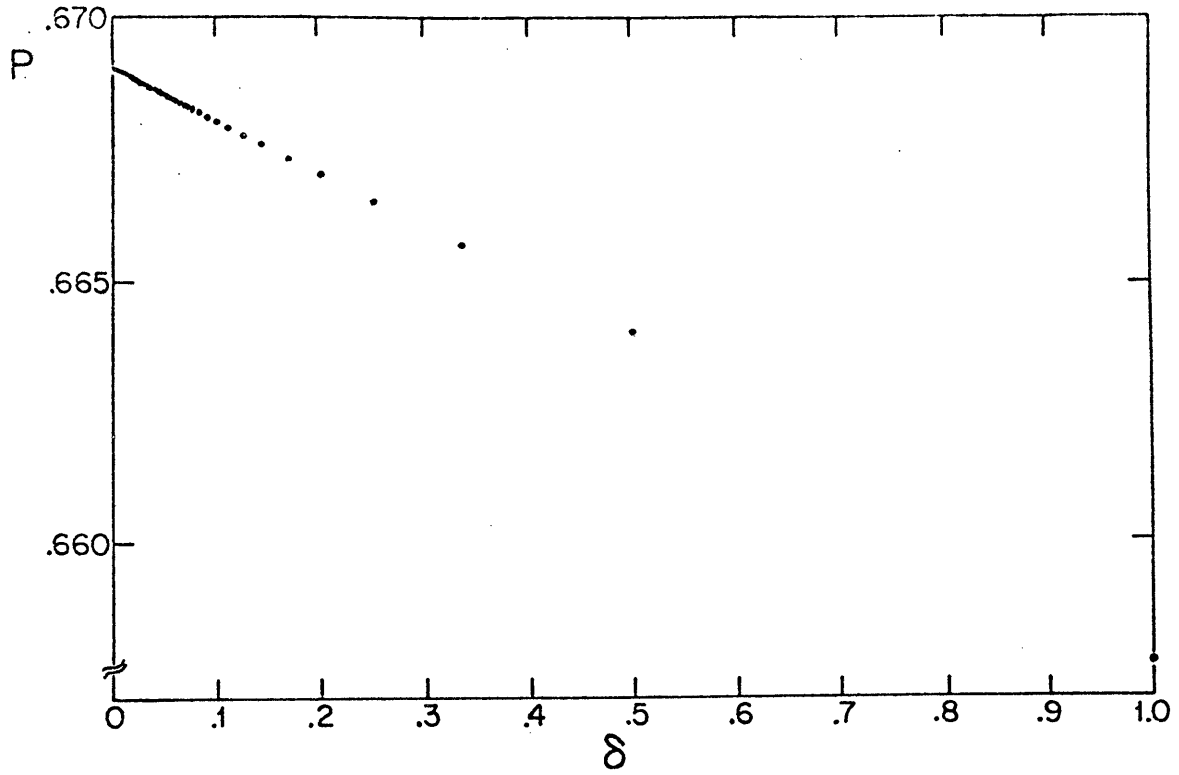

Figure 2.17 Production rate for discrete 2-machine line, where $p_1 = .05\delta$, $r_1 = .2\delta$, $p_2 = .05\delta$, $r_2 = .15\delta$, $N = 4/\delta$ as $\delta \rightarrow 0$ such that $1/\delta$ is an integer.

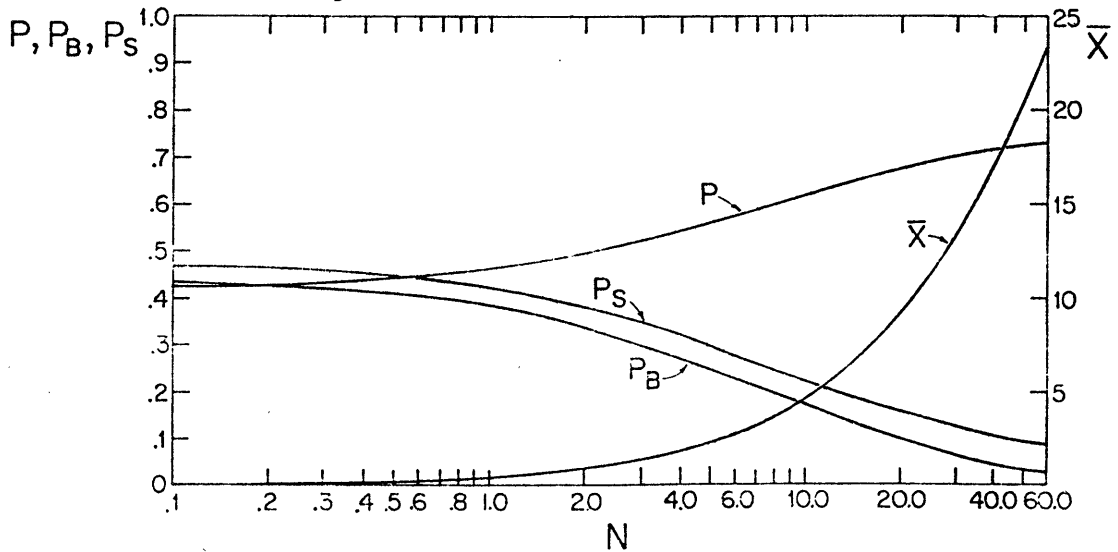

Figure 2.18 Performance measures plotted against storage capacity N -- Continuous Material Flow Model.

Figures 2.18 - 2.20.

In Figure 2.18, the storage capacity N varies in the range $[.1, 60]$. The production rate is seen to approach asymptotes as $N \rightarrow 0$ and $N \rightarrow \infty$. The first stage has the lowest production rate in isolation. Thus, it becomes the bottleneck as $N \rightarrow \infty$. It is shown in Schick and Gershwin (1978)* that the forced down probability of a bottleneck stage in a discrete line approaches 0 as $N \rightarrow \infty$. Accordingly, p_B tends toward zero as the storage increases in Figure 2.18.

If the first stage in the line is less productive than the second, the average in-process inventory reaches a limit (Schick and Gershwin (1978))* . This is not evident in Figure 2.18, where \bar{x} appears to be increasing without bound. However, this is only because \bar{x} does not level off for the storage capacity range $[.1, 60]$. The average in-process inventory for the same system parameters is plotted in Figure 2.19 (Curve 1) for the range $[.1, 1000]$. Here, it is clear that \bar{x} approaches a limit as $N \rightarrow \infty$. This also implies that the average fraction of the buffer storage utilized approaches zero as $N \rightarrow \infty$. The average in-process inventory for a system where stages 1 and 2 have been switched is also plotted on Figure 2.19 (Curve 2). Here, \bar{x} increases without bound, since the upstream stage is now more productive than the downstream stage. Furthermore, the average in-process inventories for the original and reversed production lines are complementary, i.e., add up to N (see Schick and Gershwin (1978), Ammar (1980), and Ammar and Gershwin (1980))* .

Finally, the performance measures are plotted against μ_1 , the processing speed of the first stage, in Figure 2.20. As μ_1 increases, the average in-process inventory increases. This is natural since the upstream stage puts more material into the storage than the downstream stage can remove, for large μ_1 . As a result, p_S decreases while p_B increases.

The production rate of the system, P , increases with μ_1 for small μ_1 until the second stage becomes limiting, at which time P approaches an asymptote. The asymptote is the production rate in isolation of stage 2.

2.4.2 Three-Machine Results

Three-machine results are available only for the deterministic processing time model. Some results were calculated by Schick and Gershwin (1978)* . They appear in Figures 2.21 - 2.23 where the line efficiency is plotted against the capacity of one of the storages, while the other is held to two or three values.

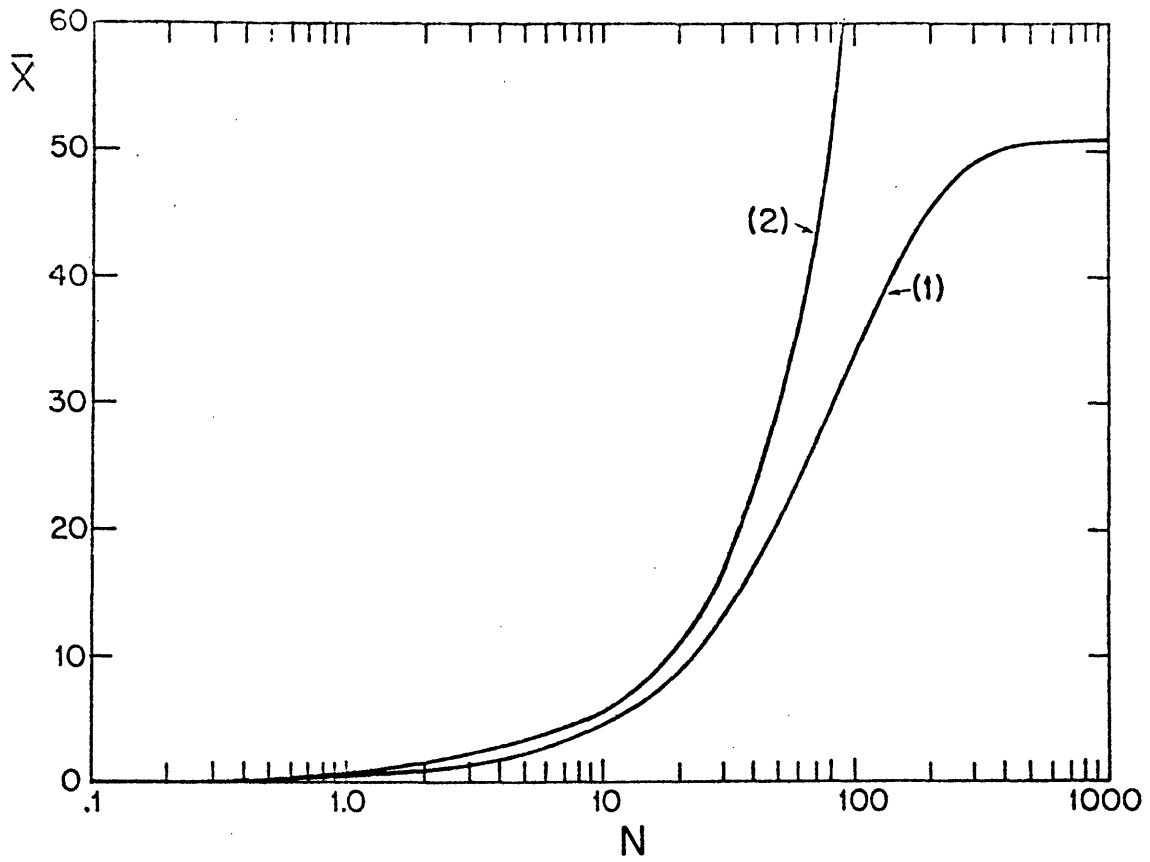

Figure 2.19 Average in-process inventory plotted against storage capacity N -- Continuous Model.

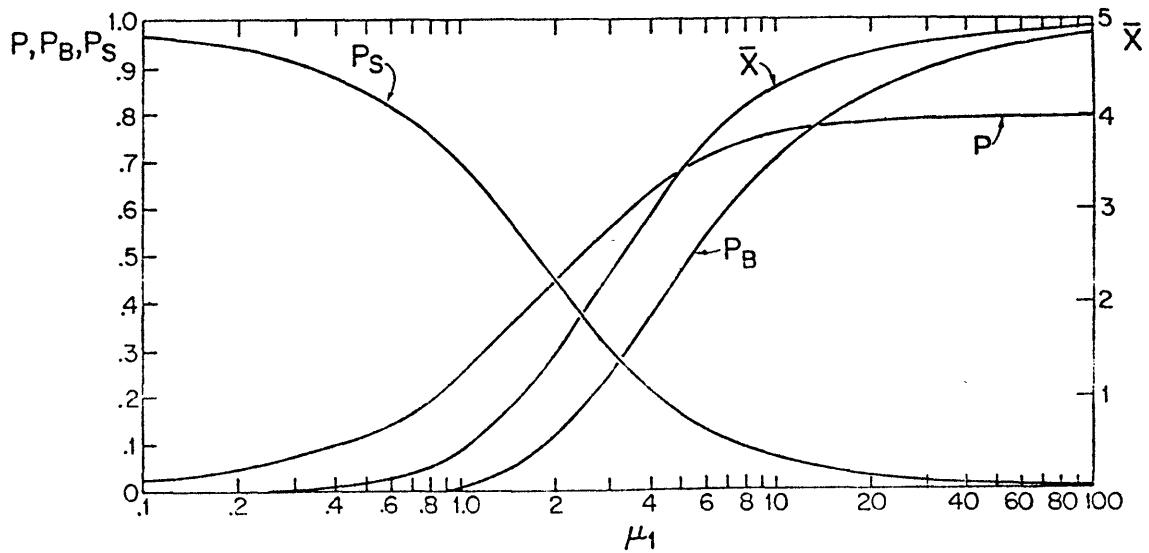

Figure 2.20 Performance measures plotted against the processing speed of stage 1, μ_1 -- Continuous Model.

In Figure 2.21, the last machine is most efficient, so that workpieces produced by the second machine are most often instantly processed by the third machine. Thus, the second storage is often nearly empty, and little is gained by providing it with a large capacity. On the other hand, the efficiency in isolation of the first machine is close to that of the downstream segment of the line (i.e., the portion of the line downstream of it, consisting of machine 2, storage 2, and machine 3). Thus, it is not profitable to provide storage space between machines 2 and 3, though it is useful to provide a buffer between machines 1 and 2.

In Figure 2.22, the first machine is most efficient. Thus, the first storage is often nearly full, and the downstream segment of the line operates most of the time as if in isolation. On the other hand, the efficiency of the third machine is close to that of the upstream segment of the line (machines 1 and 2, storage 1). Thus, little is gained by providing the first storage with a large capacity, although it is useful to have a large storage between machines 2 and 3.

In Figure 2.23, all machines have equal efficiencies in isolation, and the effects of added storage capacity are most clearly visible in this case. Furthermore, it is observed that the production rate is symmetrical with respect to the orientation of the system. See Section 2.5.

These examples indicate once again that storages act best as buffers to temporary fluctuations in the system. If the efficiencies of machines are very different, storages do not improve production rate; if the line is well balanced, the temporary breakdowns are to a certain extent compensated for by buffer storages.

Pomerance (1979)* performed a large number of numerical experiments with three-machine lines. She made a similar observation about system symmetry which influenced the development of the equivalence concept summarized in Section 2.5.

Figure 2.24 shows how variations in the failure probability of machine 3, p_3 , affect line efficiency, E . The curves represent different values of the failure probability of machine 2, p_2 . All other input parameters are constant, as indicated. Note that the first machine has a high efficiency in isolation ($e_1 = .8$), and should not be a bottleneck.

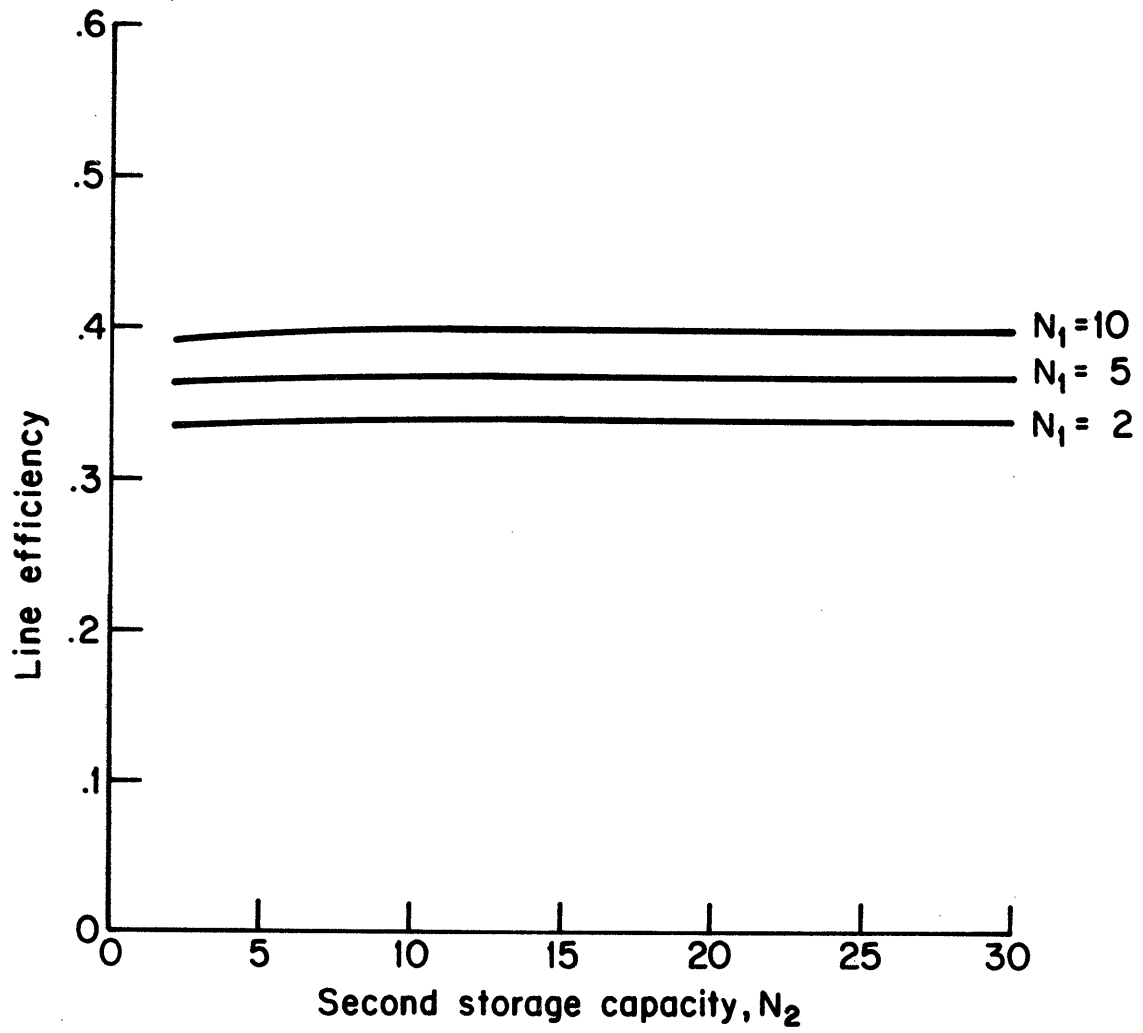

Figure 2.21 Steady-state line efficiency for a three-machine transfer line with a very efficient third machine.

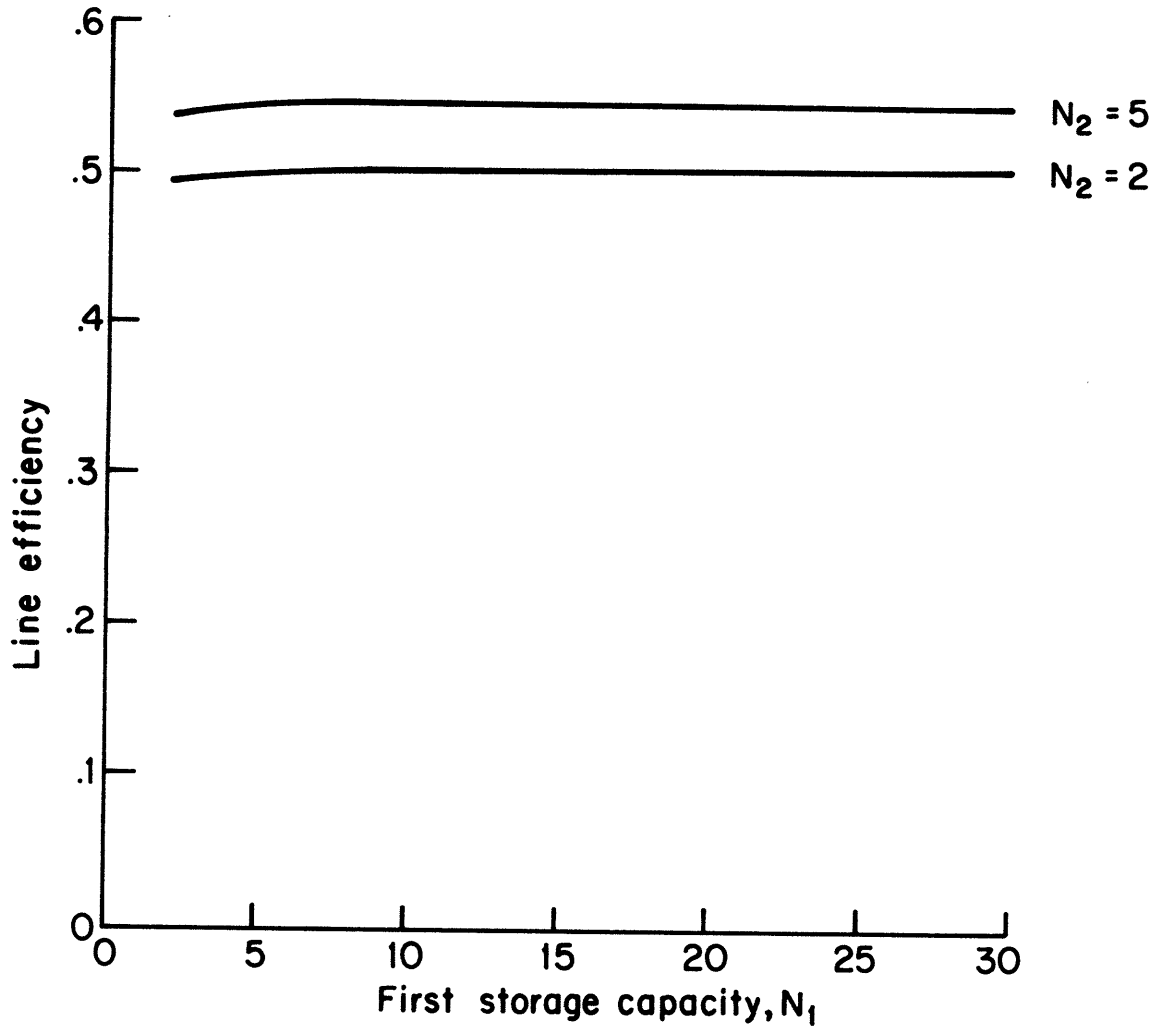

Figure 2.22 Steady-state line efficiency for a three-machine transfer line with a very efficient first machine.

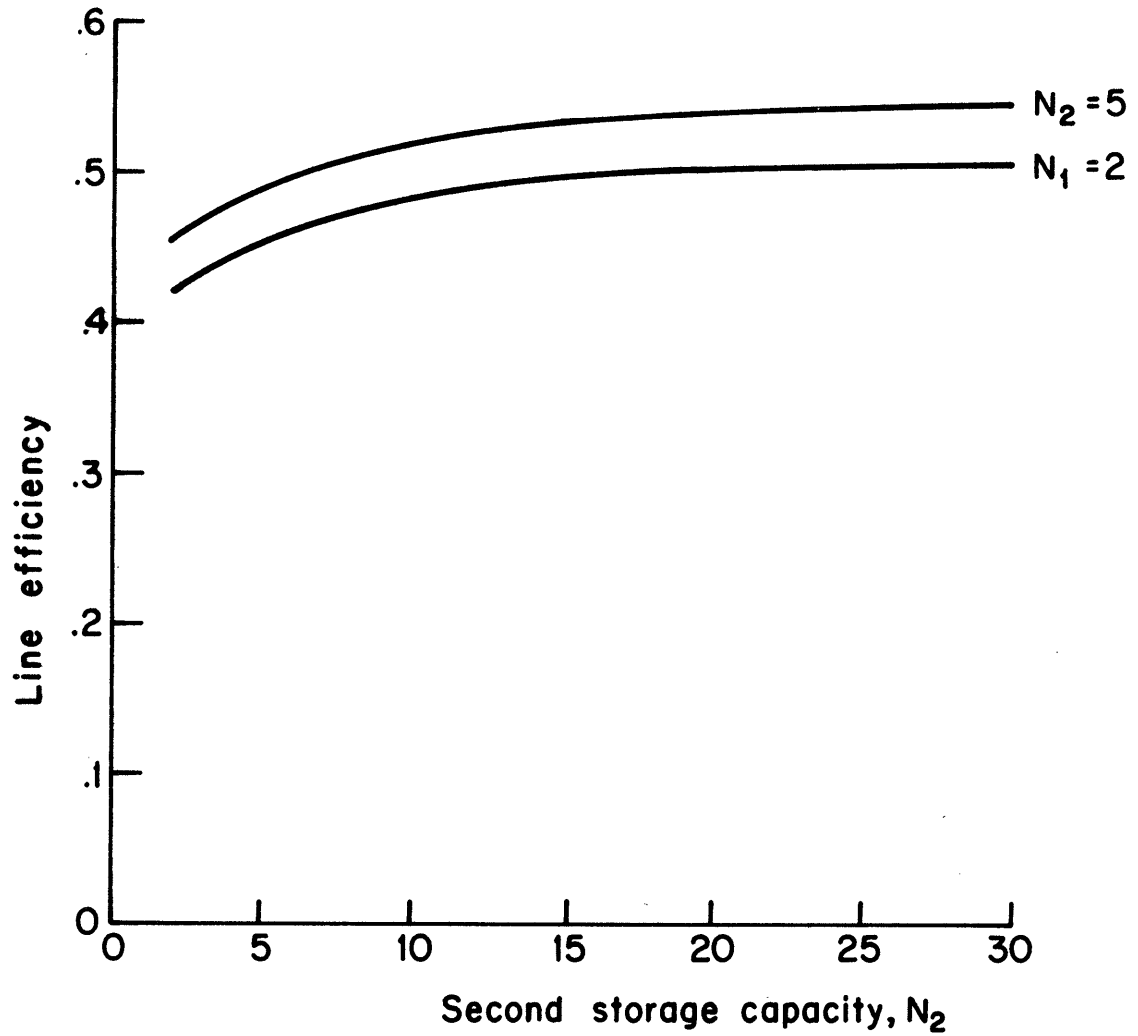

Figure 2.23 Steady-state line efficiency for a three-machine transfer line with identical machines.

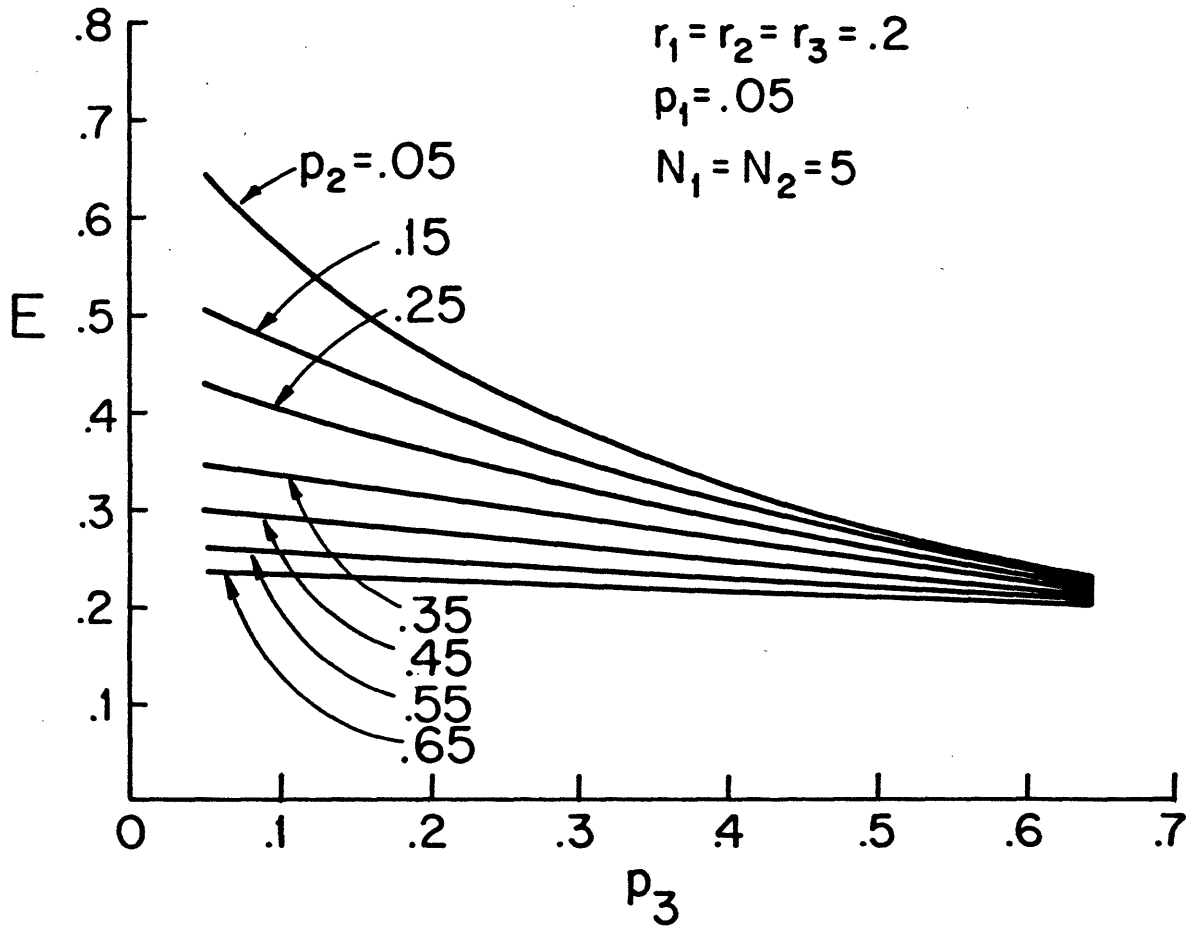

Figure 2.24 Variations in the failure probability of one machine affecting line efficiency.

An increase of .1 in p_3 produces the greatest change in E when p_2 and p_3 are low. There are two explanations. First, going from .05 to .15 is simply a larger percentage change than going from .55 to .65. Second, when the efficiencies in isolation of all machines are high, as is the case for low values of p_2 and p_3 , the line is very efficient. As p_3 increases, the production rate of machine 3 will become less than that of the other machines. The first two machines will be limited by the third machine; they are not permitted to produce workpieces faster than machine 3 can remove them from the line. When p_2 or p_3 is high, the corresponding machine is a bottleneck.

The rate at which a workpiece enters storage 1 is the rate at which it is processed by machine 1. It leaves storage 1 when machine 2 accepts it, undergoes processing by machine 2 and is deposited in storage 2 until machine 3 accepts it. Its entrances into storage 1 will be delayed if and only if machine 1 is blocked or failed. Its entrances into storage 2 is subject to delays encountered at machine 1 as well as failure or blockage of machine 2. In a balanced line, we expect that since it is more difficult for workpieces to enter the second storage than the first, \bar{n}_2 will be less than \bar{n}_1 . In unbalanced lines, we expect that the effect on the storage levels of different machine production rates (in isolation) will be much stronger than the effect on storage levels caused by the inherent potential delay workpieces are subject to.

Figure 2.25 shows how the variation of p_2 and p_3 affects expected in-process inventory, I . We see that as the third machine becomes less efficient, I increases. The explanation we offer is that in each case, the first machine is very efficient, and for low p_2 , the second machine has high efficiency. This indicates that workpieces will rapidly enter the line.

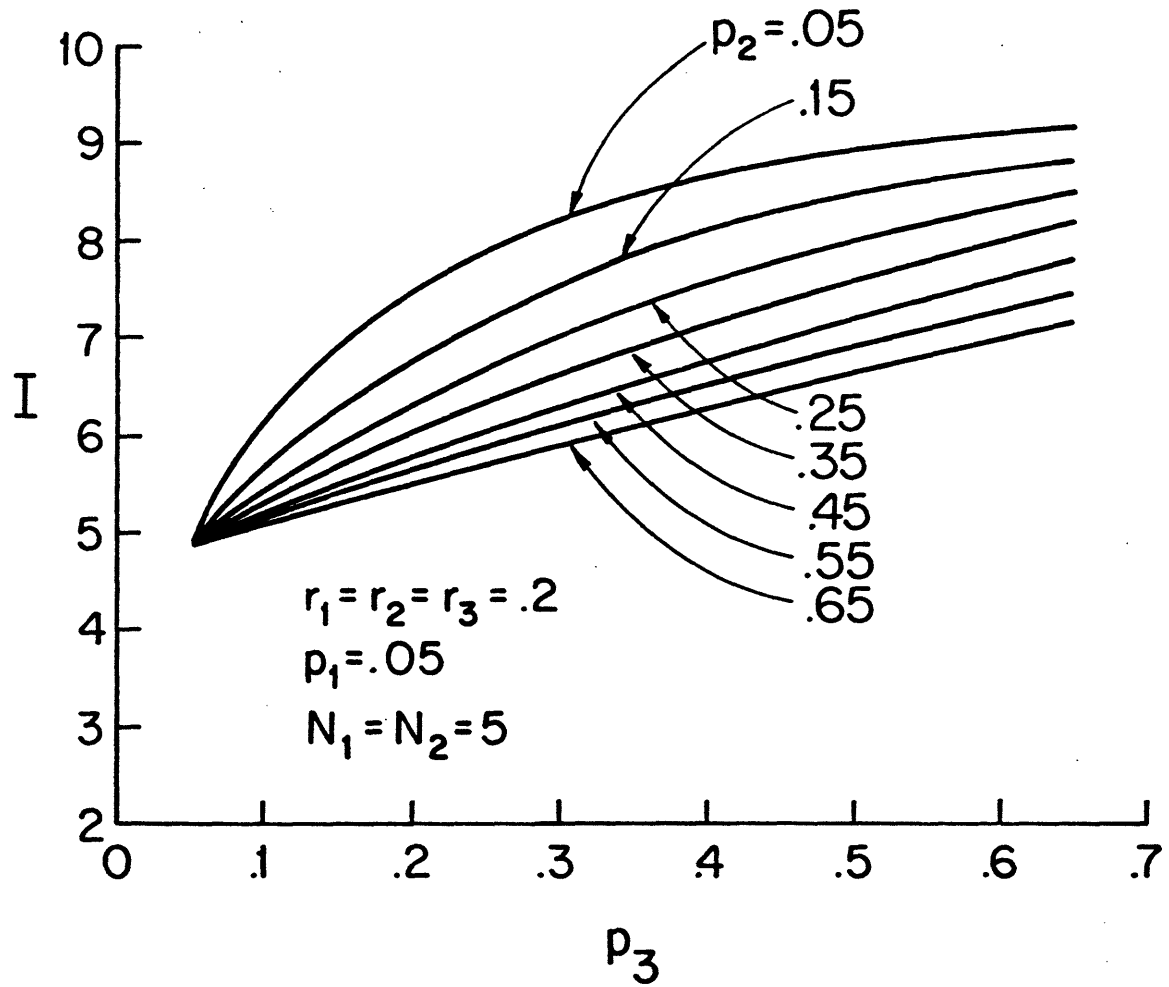

Figure 2.25 Variations in the failure probability of one machine affecting expected in-process inventory.

The decreasing efficiency of machine 3 tends to cause machine 2 to be blocked long enough to block machine 1. The relationship between machine 3 and machine 1 is indirect, and we expect it to be much weaker than the relationship between machine 2 and machine 1. Thus it is reasonable to consider the rate at which workpieces enter the line as a function of machine 1, storage 1 and machine 2. However, as machine 3 becomes less efficient, fewer workpieces will leave the line in a given observation period. They will be delayed in the storages. We expect that the level of storage 2 will increase more than the level of storage 1. This is confirmed by Pomerance (1979)*.

For constant p_3 , we see that increasing p_2 decreases I . As the second machine becomes less efficient, and the first machine is invariant, we expect \bar{n}_1 to rise. We expect \bar{n}_2 to decrease, because machine 3 has the same rate of removing workpieces, but machine 2 deposits them less frequently. Since I , which is the sum of \bar{n}_1 and \bar{n}_2 , is decreasing, we conclude that \bar{n}_2 decreases faster than \bar{n}_1 increases when machine 2 becomes less efficient. We suggest the cause is that a less efficient second machine accentuates the inherent potential delay workpieces are subject to.

2.5 Equivalence

A major advance in the analysis of manufacturing networks is the concept of equivalence. Ammar (1980)* and Gershwin and Ammar (1980)* present some fundamental equivalence properties for queueing models of manufacturing networks. The basic tool used for arriving at these properties is the analysis of hole (or empty space) motion in the network. Specifically, it is shown that networks can be grouped into equivalence classes, where members of the same class can have different layouts. The relationships among the performance measures of members of the same

class are exhibited. These results are of interest to designers of manufacturing systems as well as other systems that can be modeled as networks of queues.

The reversibility property of transfer lines is one that has been the subject of some recent research (Hillier and Bolling, 1977; Dattatreya, 1978; Muth, 1979). It states that the reversal of the order of operations in a transfer line leaves the production rate unchanged. Ammar and Gershwin show that transfer line reversibility is a consequence of equivalence. However they also show that, although production rate is unaffected by line reversal, another performance measure, the mean in-process inventory, does change. In Ammar(1980)*, the A/D network considered is deterministic (i.e., deterministic processing time, geometric repair and failure times) while the system considered by Ammar and Gershwin (1980)* is the reliable exponential model.

The equivalence concept depends on the concepts of a hole and of duality. A hole in a manufacturing network is defined as an empty space. Thus a buffer of capacity N that contains n parts has $N-n$ holes.

In a manufacturing network, holes or empty spaces move in the opposite direction of parts. (See Fig. 2.26). At the start of a cycle, a machine takes one part from each of its upstream buffers which increases the number of empty spaces or holes in them by one. Also at the end of a cycle when a machine deposits the disassembled product into its downstream buffers it is decreasing the number of holes in each of these buffers by one. Thus every end of cycle is an event of part production, while every beginning-of-cycle is a hole production event. Since every end-of-cycle must have a corresponding beginning of cycle, every part production event corresponds to a hole production event.

Note that a full buffer has no holes, and an empty buffer is full of holes. Hence a machine starved of parts is blocked by holes and also a machine blocked by parts is starved of holes. Also note that where we assume an infinite supply of parts, this is equivalent to having an infinite room for holes. Similarly an infinite room for parts is equivalent to an infinite supply of holes. Table 2.1 summarizes the part-

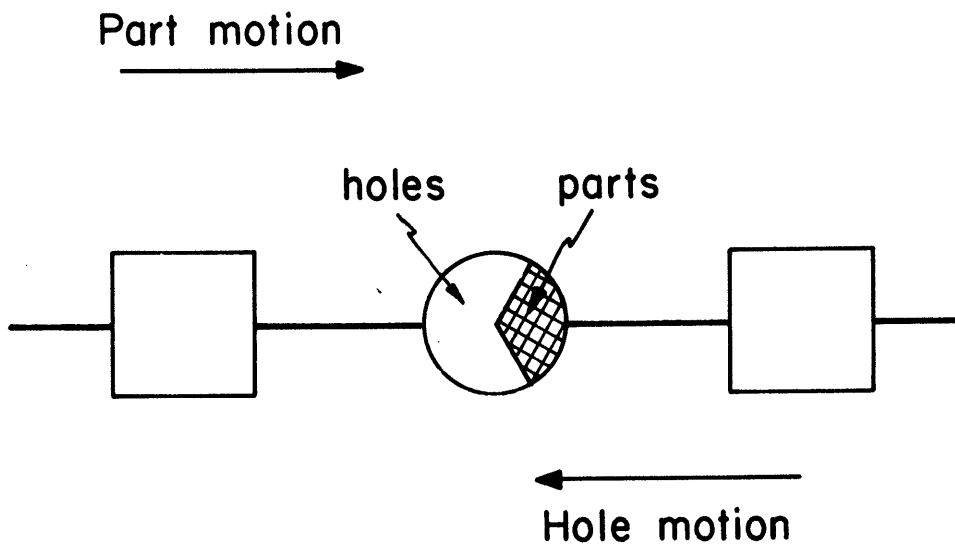

Figure 2.26 Parts and Holes

hole duality ideas introduced here.

Parts	Holes
n	N-n
room	supply
supply	room
starvation	blockage
blockage	starvation

Table 2.1 Part-Hole Duality

A manufacturing network (M) is i-dual to another network (M') if part motion in buffer i of M' corresponds to hole motion in buffer i of M, and if otherwise the networks M and M' are identical. Note that this condition requires buffer i to have the same capacity in both networks.

It is shown that networks that are i-dual to one another have essentially the same probabilistic behavior. That is, they would be identical if the states of one were relabelled. The concept is extended to equivalence by forming the set of all systems that are i-dual to a given system, for some i. That set is enhanced by adding all other systems that are i-dual to some system in it, and continuing the process until it terminates (as it must if the original network was finite).

Systems that are equivalent have the same production rate. Corresponding buffers have average in-process inventories that satisfy either

$$\bar{n}'_i = \bar{n}_i \quad (2.14a)$$

or

$$\bar{n}_i + \bar{n}'_i = N_i \quad (2.14b)$$

where \bar{n}_i, \bar{n}'_i are the average in-process inventories of buffer i in systems

M and M' , and N_i is their capacity.

An example of an equivalence class is shown in Figure 2.27. Machines labelled with the same number are assumed to have the same speed and reliability parameters, and buffers with the same label have the same capacity. The four systems are the forward (F) and reversed (R) transfer lines, and the assembly (A) and disassembly (D) networks. Systems that are i-dual have labelled double arrows between them, with the label indicating the value of i .

Equivalence is important because it provides insight into systems of this kind, and possibly other kinds of systems as well. It also saves computational effort: only one computer program is required for all the systems in Fig. 2.27, not three. In addition, the storage allocating simulation procedure of Ho et al. (1979) applies to networks consisting of two transfer lines leading to a single assembly machine, and not only to transfer lines, which was all Ho and his colleagues had intended.

2.6 Conclusion

While not all problems have been solved, a significant advance has been made in the study of assembly/disassembly systems. A collection of models has been formulated that cover a wide variety of manufacturing settings. Relationships among these models have been explored. A procedure for getting exact solutions has been applied to smaller networks and refinements are under study to allow it to be applied to larger systems. The concept of equivalence establishes relationships among systems of widely differing layout.

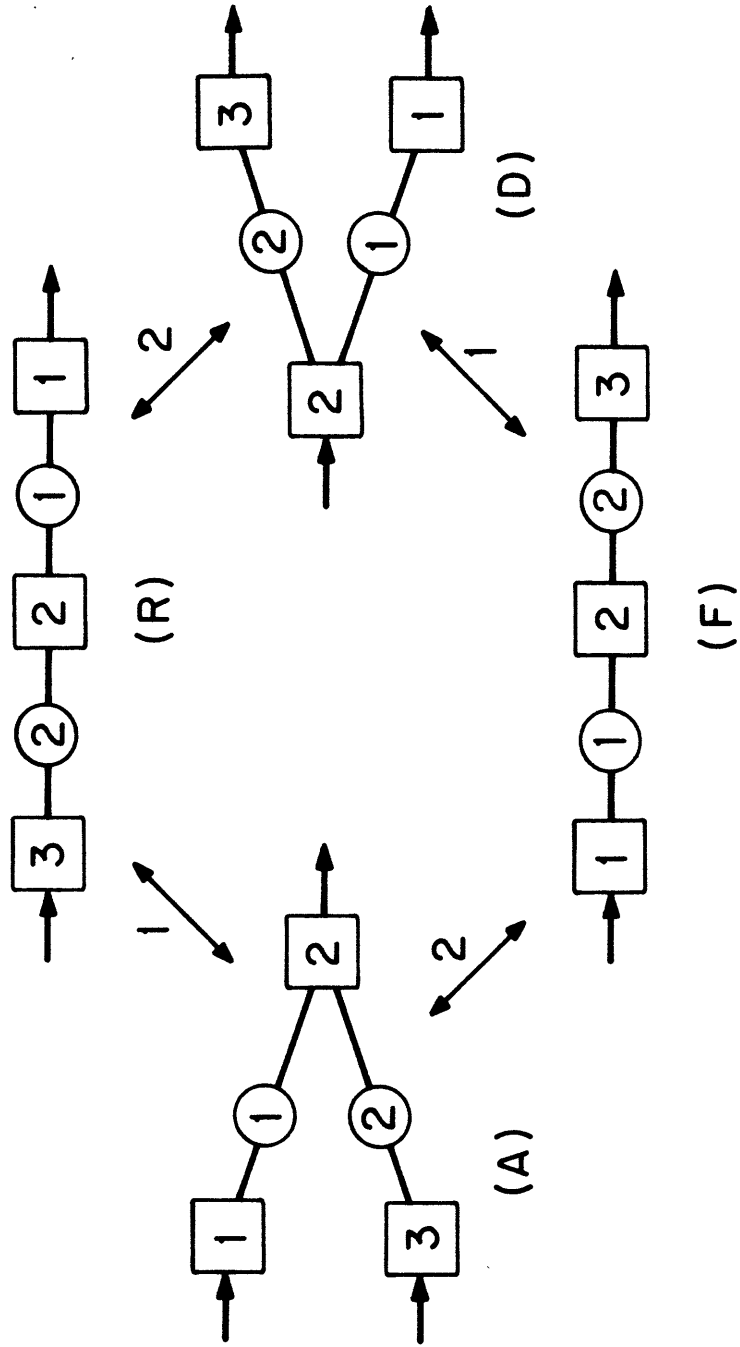

Figure 2.27 A Two-Buffer, Three-Machine Equivalence Class

3. ROUTING, SCHEDULING, AND COMPLEXITY THEORY

3.1 Introduction

An important conclusion that was reached, based on our industrial visits, was that the scheduling of tasks to machines is a problem of general interest. Supervisors at the factory floor repeatedly mentioned that schedules were often unrealistic or inefficient, resulting in excessive idle time of expensive machines, and that the effect on machine utilization of intermediate buffers was not fully understood. It was widely admitted that in a batch manufacturing environment the problems of flowshop scheduling became very complicated as the number of different jobs to be executed, especially those requiring different machining and setup times, increases. As a consequence, a decision was made to study the available literature on flowshop scheduling, with special emphasis upon the effects of buffers in reducing the time to complete a set of jobs. In particular, we investigated the dependence of production schedule lengths and machine utilization upon the existence, size, and physical nature (first-in-first-out or flexible-in-out) of buffers. We soon discovered that during the past five years a tremendous amount of work had been carried out in scheduling theory, primarily by computer science researchers in the general area of complexity theory. The connection between scheduling theory and complexity theory is of great interest and usefulness, as a means to quantify the complexity of flexible manufacturing systems.

As a consequence, a part of the research effort to date has been directed to understanding the available results of deterministic scheduling theory, and its interrelations with system science, operations research, and computer science. We were able to appreciate the existing theoretical and algorithmic results in the context of flexible manufacturing networks, and we have obtained some significant results, which are of theoretical and practical importance.

The conceptual models used in scheduling theory are simple in structure, and consequently they are meaningful for a large variety of appli-

cations. Briefly, the general models studied in scheduling theory assume that one has a set of tasks or jobs that have to be executed, and a set of machines or resources that have to be used in executing these tasks. In almost all cases the models are deterministic, that is, the information describing the tasks and the machines is assumed to be known in advance. This data includes a table of the jobs that have to be carried out, any operational precedence constraints that must be obeyed, the times that each task requires in different machines, and the number of resources, namely machines and buffers, that are available for completing the job. Typical problems examined in the literature include the minimization of the time required to complete a set of jobs, and scheduling to meet due dates or deadlines.

The chief difficulty with this class of problems is their computational complexity. We have taken three approaches to mitigate this difficulty. In the first two (in Sections 3.2 and 3.3), we have used the tools and formulations in the complexity and scheduling literature, adapted them to our purposes, and extended them. In the third, in Section 3.4, we have adapted methods that have been widely used in transportation and communication network problems.

3.2 Traveling Salesman Formulations

The most recent advances in the scheduling literature are due to the fact that a large number of classical problems can be reformulated and re-examined in the context of the theory of algorithms and computation. We shall review critically the central ideas in this section. The outcome of this literature search, and our own research, includes the identification of an efficient optimal algorithm for scheduling, heuristic suboptimal algorithms that require less computation time and include guaranteed performance bounds, efficient enumerative and iterative methods, as well as mathematical descriptions of the complexity of a wide variety of scheduling and sequencing problems.

We believe that a fundamental study of combinatorial structures is an appropriate vehicle for providing deeper insight in the general area

of alternate manufacturing configurations, especially in the batch production mode. We do realize that there are several unresolved issues, but we feel that scheduling, since it is the area best understood and since it has been successfully related to other combinatorial problems, is an important area for future reserach.

It is interesting to note that several versions of scheduling and flowshop problems can be related to famous combinatorial problems such as:

(1) The Traveling Salesman Problem (TSP): given a graph, whose edges have costs, determine the tour that visits all the nodes exactly once following a path of minimal cost.

(2) The Partition Problem: given a list of integers, can it be partitioned into two sets with equal sums?

(3) Euler's Problem: find a path which traverses all edges of a graph.

(4) The Matching Problem: find the maximum subset of edges in the graph with the property that no two edges share the same node.

This connection of scheduling in flowshops with problems in complexity theory, particularly with the traveling salesman problem, will become evident in the description of the research conducted to date. As a result of the rapid expansion of the theory of algorithms during the past decade, a number of open theoretical questions in scheduling theory have been identified, important not only in manufacturing applications but in other branches of applied combinatorics as well. Two excellent survey articles (Lewis and Papadimitriou, 1978, and Graham, 1978) have recently appeared in Scientific American, which vividly illustrate the facinating issues of scheduling problems, the theoretical difficulties, and their potential applications to several important problems.

3.2.1 The Computation Complexity of Problems and the Efficiency of Algorithms

In order to investigate the computational complexity of a problem,

the meaning of the "problem" and or "computation" must be formally defined.

A problem can be considered as a question that has YES or NO answer. Normally the problem has several parameters, in other words free variables. A selection of numerical values for the parameters is called an instance of the problem. The size of the instance is the length of the data string which is used to represent the values of the parameters. This string serves as the input data for a computer program which is constructed to solve the problem. Simple mathematical abstractions, for example, automata, have been created and analyzed in order to make precise the notion of an algorithm, to determine the limits of computer capabilities, and to study the real time and memory requirements of programs (e.g. Turing machines are equivalent in computational power to any computer, in the sense that any program on a Turing machine can be performed, say, on an IBM 370 and vice versa).

The computer time required by an algorithm, expressed as a function of the size of the instance of the problem, (i.e., the amount of input data) is called the time complexity of the algorithm. The limiting behavior of the complexity of an algorithm, as size increases (for example as the number of jobs or the number of machines increases in a flowshop) is called the asymptotic time complexity. It is important to realize that the complexity of problems can often be characterized in a manner independent of particular algorithms and particular applications.

A distinct line has been drawn between easy and hard problems. Easy problems are characterized as being those which can be solved efficiently by algorithms whose asymptotic time complexity is a polynomial function of the input data. For the hard problems, all algorithms developed to date have a worst-case behavior whose asymptotic time complexity is an exponential function of the amount of input data. The hardest of these problems have been related to each other in a revealing fashion by the notion of NP-completeness, which we shall outline. A comprehensive discussion can be found in the literature (Lewis and Papadimitriou, 1978).

Problems that are known to have polynomial time solutions, such as Euler's Problem, are said to be members of the class P. Other problems, such as the Travelling Salesman Problem belong to the class NP (signifying nondeterministic polynomial), which contain the class P. In order for the problem to qualify for membership in the class NP, there need not be an efficient means of answering the YES or NO questions. What is required is that whenever the answer is YES, there be a short and convincing argument proving it. Another way of defining NP is as the class of YES or NO problems that can be solved efficiently by guessing. If one is given an instance of a problem in the class NP for which the answer happens to be YES, then, with luck, one may discover a solution fairly quickly by making a sequence of guesses; if the answer is NO, guessing cannot possibly yield an answer any faster than an exhaustive search algorithm could. For the Travelling Salesman Problem, where we ask whether it is possible to make a tour of all nodes with cost less than a given number C, answering YES can be done convincingly by exhibiting such a tour, which one could have guessed. Answering NO is more difficult, because, in order to be convincing, we must list all possible tours and demonstrate that they have cost more than C.

It is logical to consider as the hardest of these NP problems those for which, if an efficient algorithm existed, it could be used as a subroutine to solve all problems in the class NP efficiently. These remarkable problems are the so-called NP-complete problems.

In his original work, Cook (1971) proved that the satisfiability problem for Boolean expressions is NP-complete. (The satisfiability problem is: given a Boolean expression, does an assignment of truth to values 0 and 1 to its variables exist that makes the expression true?) Since then Karp (1972) (and many other researchers) have greatly extended this class of NP-complete problems with many practical problems. For the significance of these results, we present the following remarks.

(a) Proving that a new problem is hard, in other words, proving that a problem is NP-complete, is generally achieved by efficiently reducing it to an already known NP-complete problem. Its membership

in NP is usually easy to check, and since all problems in NP reduce to the known NP-complete problems this completes the argument. Thus, determining NP-completeness is significant because this would provide the borderline between easy and hard problems, and would have significant impact on the amount of real-time calculations, say, for flowshop scheduling in a batch manufacturing environment.

(b) If a problem has been shown to be NP-complete, then its computational complexity grows rapidly with the size of the parameters. For example, suppose that we have a scheduling problem that involves 20 tasks. Suppose that the optimal algorithm grows factorially. Even if we can assume that a computer could compare 1,000,000 schedules per second, the fact that $20!$ schedules must be compared implies that the computer would take over 76,000 years to arrive at the optimal solution. Thus an extremely important area for research is to develop fast heuristic algorithms that provide approximate and suboptimal solutions for NP-complete optimization problems. It is equally important to determine upper bounds for these fast heuristic algorithms, so that one is guaranteed that the use of this heuristic algorithm will yield a solution that is no worse than a prespecified multiple of the truly optimal solution, which may be impossible to obtain. In the following sub-section we shall present such bounds for a class of flowshop problems with buffers.

3.2.2 Summary of Our Research

Our research in scheduling theory and computational complexity has involved a very careful evaluation of the existing literature, with due attention to problems that are clearly relevant to flexible manufacturing. Detailed documentation of our results can be found in Papadimitriou and Kanellakis (1978, 1980)*, Kanellakis (1978)*, and Kanellakis and Papadimitriou (1979, 1980)*.

Our research has been concerned with classical flowshops involving an arbitrary number of machines, m , and an arbitrary number, n , of jobs, with and without intermediate buffers. Each job is represented by m

positive integers, which denote the setup and execution time requirements on the first machine, second machine, third machine and so on.

We assume that the following conditions are satisfied:

(a) No machine ever executes two jobs at the same time. If a job starts on a machine, it continues until it finishes (no preemption).

(b) No job starts on any machine before its operation on the previous machine ends.

(c) All jobs are executed on all machines in the same order. This is called permutation scheduling.

(d) The problem is to schedule the jobs in this flowshop such that the completion time (makespan) is as short as possible.

Zero-Buffer Flowshops

Zero-buffer flowshops can be transformed into the so-called Asymmetrical Travelling Salesman Problem. Each job defines a node in a graph, or equivalently a city, in the Travelling Salesman Problem. Each node is interconnected to each other node by a directed arc whose cost can be calculated given the time that each job i has to spend in machine j . The asymmetry of the problem arises by the fact that the cost of going from node 1 to node 2 is different from the cost of going from node 2 to node 1. The solution to the Asymmetrical Travelling Salesman Problem requires finding a tour that visits each node precisely once with a minimal total cost. This defines the optimal schedule for the classical flowshop with zero intermediate buffers. It is obvious that the problem gets complicated as the number of jobs, n , or the number of machines, m , increases. We have been interested in finding the inherent computational complexity for this class of problems, since this has obvious consequences for the amount of real time computation necessary to optimally schedule jobs in a flowshop subsystem in a general flexible manufacturing network.

Examination of the previous literature showed that the two-machine case is an easy problem and can be efficiently solved. On the other hand, if the number of machines, m , is a parameter, the problem is

known to be NP-complete (Lenstra, 1976). The complexity of the problem was an open question if the number of machines, m , is fixed, as is the case in manufacturing problems. Our main result in this area is summarized by the following theorem.

Theorem 1. The optimal scheduling problem is NP-complete for four or more machines.

The proof of the above theorem is extremely involved. It uses extensively the general techniques presented by Garey *et al.* (1976). We shall make certain important remarks associated with this problem.

Since the two-machine problem is easy, and we proved that the four or more machine problem is hard, the only open question is whether or not the three-machine, zero-buffer flowshop problem is NP-complete. We have been unable to obtain a proof one way or another.

The Symmetric Travelling Salesman Problem is known to be NP-complete. On the other hand, there are several heuristic algorithms that can be used to obtain approximate solution for symmetric travelling salesman problems (Lin and Kernighan, 1973, and Cristofides, 1976). However, efficient heuristic algorithms for the asymmetric travelling salesman problem have not received much attention (Thompson, 1975). We have been able to devise a heuristic algorithm for the asymmetric travelling salesman problem based on an extension of the Lin-Kernighan algorithm involving ideas of neighborhood search. Numerical experience indicates that its performance is comparable to the Lin-Kernighan algorithm for the symmetric case. This is documented in Kanellakis and Papadimitriou (1979, 1980)*.

Theorem 1 implies that exact schedules for four-machine zero-buffer or larger flowshops precludes any direct optimization. This reinforces our approach of using a more hierarchical approach to the problem.

We also believe that Theorem 1 represents an important contribution to the complexity theory literature.

Effects of Buffers

The second phase of our research in this area has been concerned with the effects of buffers in the overall flowshop problem. We remark that buffers are extremely important in the improvement of production rates when the machines are unreliable (Section 2). It should be intuitively obvious, and it can be proven mathematically, that the introduction of buffers in a classical flowshop problem results in shorter schedules. We shall illustrate this by a simple example, because this also will help illustrate the general results that we have been able to obtain on the effects of buffers on flowshops. Figure 3.1 shows a very simple two-machine flowshop where the two machines are separated by a buffer. In Case I we do not have a buffer, and in Case II the buffer has unit capacity. We are interested in finding the best schedule for the listed four jobs whose processing times are also shown in Figure 3.1.

Figure 3.2 shows the optimal schedule for the zero-buffer case, which was obtained by translating the problem to an asymmetrical travelling salesman problem and finding the optimal solution. As shown in Figure 3.2 the best sequence of jobs is 1, 3, 2, 4. The optimal schedule requires 19 units of time. Note that, in the absence of buffers, the machines remain idle over a portion of the interval. Machine 1 is idle between times 7 and 11, while machine number 2 is idle during the time interval from 2 to 5 and from 6 to 7. Thus, even the optimal schedule (in the absence of buffers) does not utilize the machines fully. Obviously, for more jobs and more machines, the idle time will increase.

Figure 3.3 shows the benefit of introducing a buffer of unit capacity between two machines, the same jobs can now be completed in 15 time units. Note that the optimal schedule has changed, and now is 1, 2, 3, 4. The reduction in the overall time for completion is due to the fact that job 3 can stay in the buffer during the time interval from 7 to 14.

Once more we were interested in understanding the computational complexity of problems in which buffers are introduced between machines.

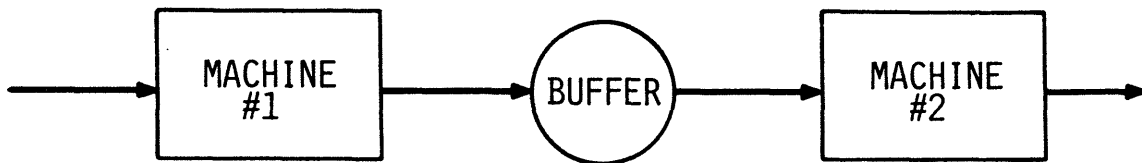

Buffer size = b ; Case I: $b = 0$, Case II: $b = 1$

JOB NO.	MACHINE #1 TIME	MACHINE #2 TIME
$i = 1$	$0 \approx \tau_{11}$	$2 = \tau_{21}$
$i = 2$	$2 = \tau_{12}$	$12 = \tau_{22}$
$i = 3$	$5 = \tau_{13}$	$1 = \tau_{23}$
$i = 4$	$8 = \tau_{14}$	$0 \approx \tau_{24}$

FIND BEST SEQUENCE OF JOBS TO MINIMIZE TIME

Figure 3.1 A Simple Example of a Two-Machine Flowshop Problem

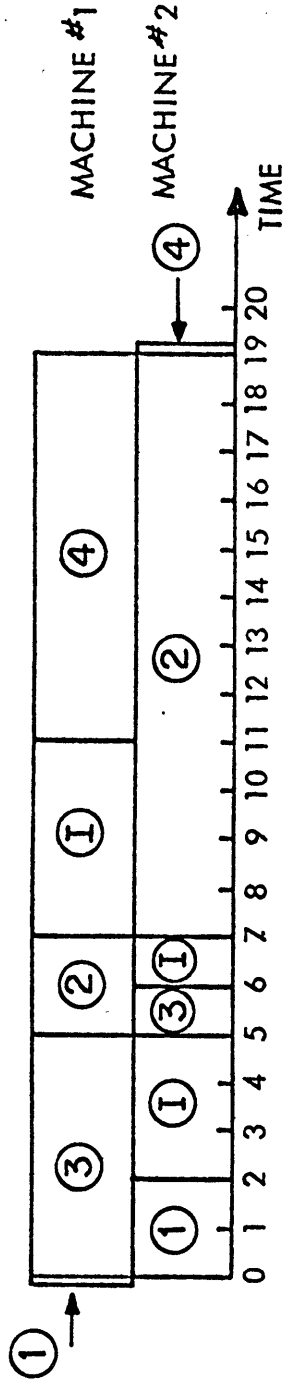

Figure 3.2 Optimal Schedule for Zero Buffer; I denotes "idle".

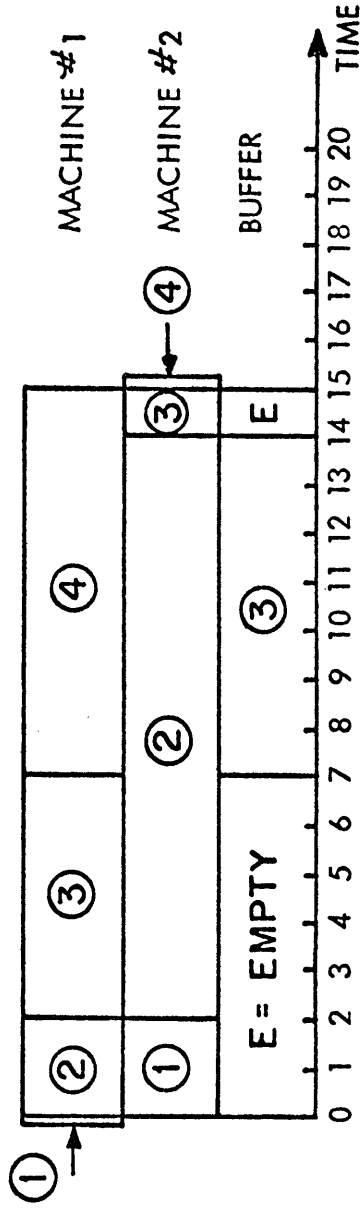

Figure 3.3 Optimal Schedule for Unity Buffer

We have obtained several results for the two-machine problem. The main results are summarized in the following theorem.

Theorem 2. For all non-zero finite buffer sizes, the two-machine flowshop problem with intermediate buffer is NP-complete.

We believe that this theorem is a contribution to the literature on computational complexity. NP-completeness has been proved for first-in-first-out buffers. However, it is clear that the problem is even more complicated when one introduces more flexible buffers. Thus, although the introduction of buffers is beneficial from the point of view of reducing the time to complete a set of jobs, the computational requirements for scheduling a large number of jobs are extremely high.

Considerable effort was devoted in deriving heuristic suboptimal algorithms with guaranteed accuracy for the two-machine, arbitrary size buffer, flowshop. Such a heuristic algorithm has been developed and it proceeds in the following way.

- 1) Solve the asymmetrical travelling salesman problem which results from the assumption that the buffers have zero size.
- 2) Compress the resulting schedule so as to take advantage of the finite buffer size.

Guaranteed bounds have been determined for this heuristic algorithm. Let b denote the size of the buffer. Then an upper bound for the performance of this heuristic algorithm is given by

$$\frac{\hat{T} - T^*}{T^*} \leq \frac{b}{b + 1} \quad ; \quad b \leq 1$$

T^* : optimal schedule time

\hat{T} : heuristic schedule time

Thus for unit buffer size, the maximum error is 50%. If the buffer size is 2, the maximum error is 67%. If the buffer size is 3, the maximum error is 75%. In general, this heuristic algorithm is always guaranteed to produce a schedule that is at most twice as long as the optimal.

Furthermore, the heuristic algorithm is extremely fast.

It should be noted that the above bounds are tight, in the sense that we can find job sets for which this heuristic algorithm attains the upper bound. These are special cases, and in fact are constructive in the sense that they give a clear cut indication of what classes of jobs should not be mixed in the same batch.

On the other hand, it is informative to evaluate the performance of a heuristic algorithm in a statistical way. This heuristic algorithm was tested by Monte Carlo simulations for different size jobs for the two-machine unit-buffer flowshop. The results are shown in Table 3.1, and they demonstrate that the degradation in the time of completion is on the average 5% greater than optimal, with a standard deviation of about 10%. Thus, statistically speaking, this heuristic algorithm performs much better than its worst case. This indicates the need for statistical methods to be introduced in the field of scheduling and complexity theory.

In summary, our literature search into the solved and unsolved problems in complexity theory (Coffman, 1976, Graham et al., 1978), as well as our research efforts to date, have given us a good feeling for the relative sizes in terms of jobs and machines of both classical and nonclassical flowshop problems that can be attacked in real time. Some system problems can be solved exactly; others require approximation techniques such as those presented here, or in the next sections, or have yet to be devised.

The significant contributions are the two algorithms which can be efficiently implemented. The guaranteed accuracy method for the two-machine flowshop provides a good solution with little computation. The Asymmetric Travelling Salesman heuristic has very good performance (in accuracy and computation time) for graphs with up to 100 nodes and is applicable to a wide class of problems, far more than just flowshops.

Table 3.1 Monte Carlo Simulation Results (10 cases for each # of jobs)

# of jobs	Mean Error	Standard Deviation %	Worst case %
4	1.5	5.1	15
5	2.4	8.1	24
6	6.3	9.7	20
7	3.7	5.7	15
8	1.8	2.9	6
9	2.7	4.1	10
10	3.1	4.0	8
11	1.5	5.6	12
12	4.5	4.2	7
13	3.1	4.0	8
14	3.1	3.7	7
15	3.2	3.3	6
16	2.8	4.6	9
17	3.0	3.0	5
18	2.1	3.0	10
19	3.1	4.5	5
20	1.5	2.2	6
21	2.7	3.4	7

3.3 Periodic Scheduling

3.3.1 Introduction

The results summarized in Section 3.2 clearly indicate that approximate methods are required for the routing and scheduling of workpieces in real flexible manufacturing systems. In this section we summarize the results of Hitz (1979)*, who renders the problem tractable by

(1) observing that although the number of workpieces required may be quite large, the number of types of workpieces may be relatively small; and

(2) studying an important special case of an FMS.

The work described in Hitz (1979)* deals with some aspects of the problem of scheduling production in a simple type of flexible manufacturing system that might be called a Flexible Flow Shop (FFS). This is a serial arrangement of multipurpose machines connected by a fixed conveyor system. The conveyors are equipped with appropriate sensors and switching devices so that the transport of parts from machine to machine is fully mechanized. The first and last machines in the FFS are loading and unloading stations where parts are loaded onto, or removed from, fixtures or pallets necessary for alignment in the machines or on the conveyor. Each internal machine of the system is assumed to be capable of performing a range of similar operations, or sequences of operations. Moreover, it will be assumed that a changeover from one operation to another can be performed automatically and at negligible cost. However, only one part at a time can be processed at each machine. Typical examples of such machines might be N/C machine tools or computer-controlled assembly robots. At each internal machine of the FFS, the conveyor system has by-pass links so that it is possible for parts to visit only some of the machines in their passage through the system. For additional system flexibility, each of the machines has an entry buffer of specified capacity; in the sequel, these buffers will be assumed to operate with a first-in first-out discipline. A schematic diagram of a typical FFS is shown in Fig. 3.4.

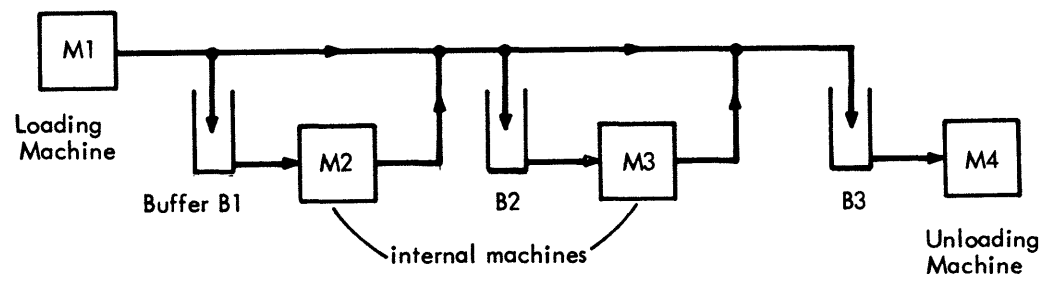

Figure 3.4 A Four-Machine Flexible Flowshop

Suppose now that such a system is to be used to produce a specific range of part types in a prescribed constant ratio, and in sufficient volume to keep the system occupied for a reasonably long time. Each part type requires a prescribed sequence of operations, and we shall assume that this can be expressed by specifying the sequence of machines to be visited by each type, and the processing time required on each machine. This means, in particular, that whenever an operation can be carried out on more than one machine, an actual part type has been split into a number of "artificial" ones, each of them associated with a distinct feasible machine sequence, and that appropriate production ratios for the artificial part types have been determined independently by considering the balance of work among machines. (See Section 3.4 for one method of doing this.) Hitz discusses only flow shops, i.e., serial arrangements of machines. However, it may be possible to convert a large class of job shops to flow shops for the purpose of using his methods.

In the literature on production scheduling, it is usually assumed that a setup cost is incurred in a changeover of a machine or production line from one part type to another. The production scheduling problem is then to determine the sizes and sequence of the batches in which the part types should be made so as to strike the best balance between setup costs and costs of holding in-process and finished inventory. In the flexible manufacturing systems considered here, however, setup or changeover costs are negligible so that an optimal mode of production will minimize work in progress by producing the required part types simultaneously rather than in a sequence of batches. The buffers in the system have the purpose of reducing machine idle time due to unequal processing times, and of providing a cushion against short-term machine breakdowns; their function is not to reduce the number of setups required.

We are thus led to the following production scheduling problem:

Given a description of the system (number of machines, buffer capacities, travel times between machines) and of the desired production (number of part types, machine

sequence for each part type, processing times on the machines, production ratios required), determine in what sequence and at what intervals parts would be loaded into the system (i.e., the first machine) so that

- (i) the output of finished parts is as large as possible, subject to the constraint that part types are produced in the prescribed ratio, and
- (ii) The steady state of maximum production in the prescribed ratios is reached as quickly as possible after startup or a momentary disturbance.

Hitz considers a deterministic version of this problem. All processing and travel times are assumed known and fixed, and all machines are considered completely reliable. He also assumes that processing and travel times are integral multiples of some fundamental time step.

With these assumptions, the problem can be formulated as a special type of jobshop scheduling problem. There is an extensive literature on this problem; excellent recent discussions of methods for scheduling both flowshops (e.g., transfer lines) and general jobshops can be found in Coffman (1976), Lageweb et al. (1977, 1978), together with extensive references to earlier work. Except in a very few simple cases, both flowshop and jobshop scheduling are well known to belong to the category of hard-to-solve NP-complete combinatorial problems which seem to be characterized by such a dearth of structure that the only feasible exact solution methods found so far are implicit enumeration type tree searches. Particularly in the case of the jobshop problem, these searches often require a massive computational effort for problems of even moderate size. This seems at least in part due to the choice of optimization criterion. Hitz reports that in all studies he has seen, the scheduling problem is stated as finding either the shortest total time (makespan) or the shortest average time weighted by jobs, in which a flowshop or jobshop can process a given fixed set of jobs.

Hitz feels that this is an unnecessarily strict optimization criterion. An important special case is where the total number of parts to be produced by the FFS in one run is so large that the system can be considered to be in an optimal state of operation whenever it pro-

duces parts in the prescribed ratio and at a steady maximum rate, both averaged over suitable time intervals. The additional time saving possible by using schedules which minimize makespan or average weighted finishing time, for the total set of parts in the run, will usually be very small.

Hitz (1979)* focuses on the problem of characterizing and computing loading sequences, or schedules, for the FFS which result in optimal steady state output, subject to constraints on the duration of startup transients, and on available buffer storages. It is shown that substantial computational savings can be obtained by replacing the minimization of makespan (or mean weighted finishing time) with the requirement that the bottleneck machine or machines be fully occupied once they have started working.

A precise definition of what is meant by an optimal loading sequence is given. The simple but basic result is established that loading sequences which lead to optimal steady state production, without constraints on buffer capacities or on the duration of start-up transients, form a very large class and are trivially easy to compute.

Constraints on the length of transients as well as buffer storage are introduced, and an implicit enumeration algorithm for computing optimal loading sequences is described. Some initial computational results are reported for the particular case of unit buffer capacity at all machines.

Extensions of these ideas are presented and it is suggested how they might be incorporated in a closed-loop system of controlling production in a flexible manufacturing system.

3.3.2 Principal Definitions and Results

Consider an FFS with K machines linked by a conveyor system such that the travel time $\tau_{j\ell}$ from the machine j to the input buffer of machine ℓ is known and fixed for all $1 \leq j < \ell \leq K$. Suppose that M part types are to be produced. Let p_{ij} denote the known fixed processing time required for a part of type i on machine j ; $p_{ij} = 0$ means that

a part of type i bypasses machine j . Suppose further that the part types are to be produced in the ratios r_i , $i=1,2,\dots,M$; of the total number α of parts produced since startup, $r_i\alpha$ parts are required to be of type i . Hitz assumes that the r_i are rational fractions. In some cases, particularly where the various part types are required for assembly into a larger unit, a tighter constraint may be appropriate: of every N consecutive parts produced by the system, n_i are required to be of type i , where $n_i = r_i N$, and where N is a reasonably small number. This leads to the notion of a "Minimal Part Set" (MPS).

Definition: A Minimal Part Set is a set of integers $\{n_1, n_2, \dots, n_M\}$ such that

$$n_i = r_i \sum_{i=1}^M n_i \stackrel{\Delta}{=} r_i N, \quad i = 1, 2, \dots, M \quad (3.1)$$

and

$$\text{g.c.d. } \{n_1, n_2, \dots, n_M\} = 1 \quad (3.2)$$

where g.c.d. (\cdot) is the greatest common divisor of its arguments.

Equation (3.2) indicates that n_1, \dots, n_M have no divisor in common other than 1.

Clearly, the system satisfies the production ratio constraints if in every set of N consecutive completed parts, n_i are of type i , $i=1,2,\dots,M$. Moreover, it is impossible to be certain that the constraints are satisfied without checking at least the last N parts produced. Thus the minimum time required to produce the N parts is, in a sense, the shortest possible response time of the system. Ideally, this will be equal to the time T required by the bottleneck (or most heavily loaded) machine or machines to process their share of work in an MPS. This time is called a period; it is given by

$$T = 1 \leq j \leq k \quad \left\{ T_j = \sum_{i=1}^M n_i p_{ij} \right\}$$

The scheduling problem is to determine a loading sequence $\{(\sigma_1, t_1), (\sigma_2, t_2), \dots\}$, (where (σ_ℓ, t_ℓ) means that a part of type σ_ℓ is loaded into

machine 1 at time t_0), which will cause the system to produce parts in the prescribed ratio and at the maximum possible rate. Clearly, the best steady state operation obtains when the system completes a minimal part set in every period T . This suggests the use of a periodic loading sequence of the form

$$\{(\sigma_1, t_1), (\sigma_2, t_2), \dots, (\sigma_N, t_N), (\sigma_1, t_1+T) \dots (\sigma_N, t_N+T), (\sigma_1, t_1+2T) \dots\}$$

where $t_1 < t_2 < \dots < t_N$, $t_N - t_1 < T$ and where $\{\sigma_1, \sigma_2, \dots, \sigma_N\}$ is some permutation of the items in a minimal part set. Any such sequence is called maximal periodic. It is convenient to use the same phrase for sequences in which the strict inequalities $t_i < t_{i+1}$ are relaxed to $t_i \leq t_{i+1}$; such sequences can occur when subsequences merge at a conveyor junction inside the system (see F2 below). In that case, the t_i will not be instants at which the part enters the system but instants at which it passes the point where the sequence is observed.

Suppose now that the FFS has the following features:

- F1: Each machine has a FIFO buffer of unlimited capacity.
- F2: The conveyor system can carry an arbitrary number of pieces on each position. This means that no part emerging from a machine will be delayed in its journey to the next machine by traffic on the conveyor. It also implies that several parts may arrive at a machine buffer simultaneously. In order to maintain deterministic behaviour throughout the system, it is assumed that parts sharing a conveyor position and destined for the same machine leave the conveyor and enter the machine's buffer according to some arbitrary but fixed rule, e.g., LIFO.

For a system with these features, any one of a large class of loading sequences will result in optimal steady-state production, as the following theorem shows.

Theorem: In a flexible flow shop with features F1 and F2, any maximal periodic loading sequence results, after a finite interval of time, in an output sequence which is itself maximal periodic.

The theorem assures us that if the system has unlimited buffer capacity at each machine, and if only steady-state output is of interest,

the scheduling problem has a simple solution: any maximal periodic loading sequence will do. After a finite time, an initially empty system will produce a minimal part set in every period.

Of course, a poor choice of loading sequence may result in a long transient. During this transient, the system will produce parts at less than the maximum possible rate, and since the sequence of parts will usually be permuted in its passage through the system, there is no assurance that an integral number of minimal part sets will be produced during the transient. Thus the output will in general satisfy the production ratio constraints only if the production during the transient is ignored.

It is possible to overcome this difficulty, as well as reduce the duration of the transient phase, by a partial preprocessing of parts which fills the machine buffers to an appropriate level prior to start-
int the maximal periodic loading sequence. This yields a heuristic scheduling algorithm which is discussed in more detail in Chapter 4 of Hitz (1979)*

Definition: A maximal periodic loading sequence will be called optimal if, when it is applied to an initially empty FFS, the following hold:

- (i) specified constraints on buffer capacity are satisfied
- (ii) the output sequence of completed parts is maximal periodic from the instant at which the first part leaves the system.

An example of an FFS scheduling problem is given in Fig. 3.5, together with an optimal schedule which satisfies the constraint of unit buffer capacity at each machine. On the chart, two-digit numbers are used to identify individual parts. For example, "52" refers to the second part of type 5. This particular part is loaded at time 16, leaves machine 1 at time 18, bypasses machine 2 to arrive at the buffer of machine 3 at time 28, waits there for 3 time steps while part 31 is processed, leaves machine 3 at time 36, and so on. It leaves the system at time 74.

(a) Problem Data:No of machines $K = 6$ No of part types $M = 5$ Minimal Part Set = $\{2,2,1,1,3\}$; Period $T = 42$ Travel times $\tau_{j\ell}$

ℓ	j				
	1	2	3	4	5
2	5				
3	10	6			
4	16	12	7		
5	21	17	12	6	
6	25	21	16	10	5

Operation times

Part type	Machine					
	1	2	3	4	5	6
1	4	6	0	0	10	2
2	4	7	5	4	0	2
3	2	0	10	9	0	1
4	2	4	7	0	4	1
5	2	0	5	7	6	1
Total	26	30	42	38	42	13

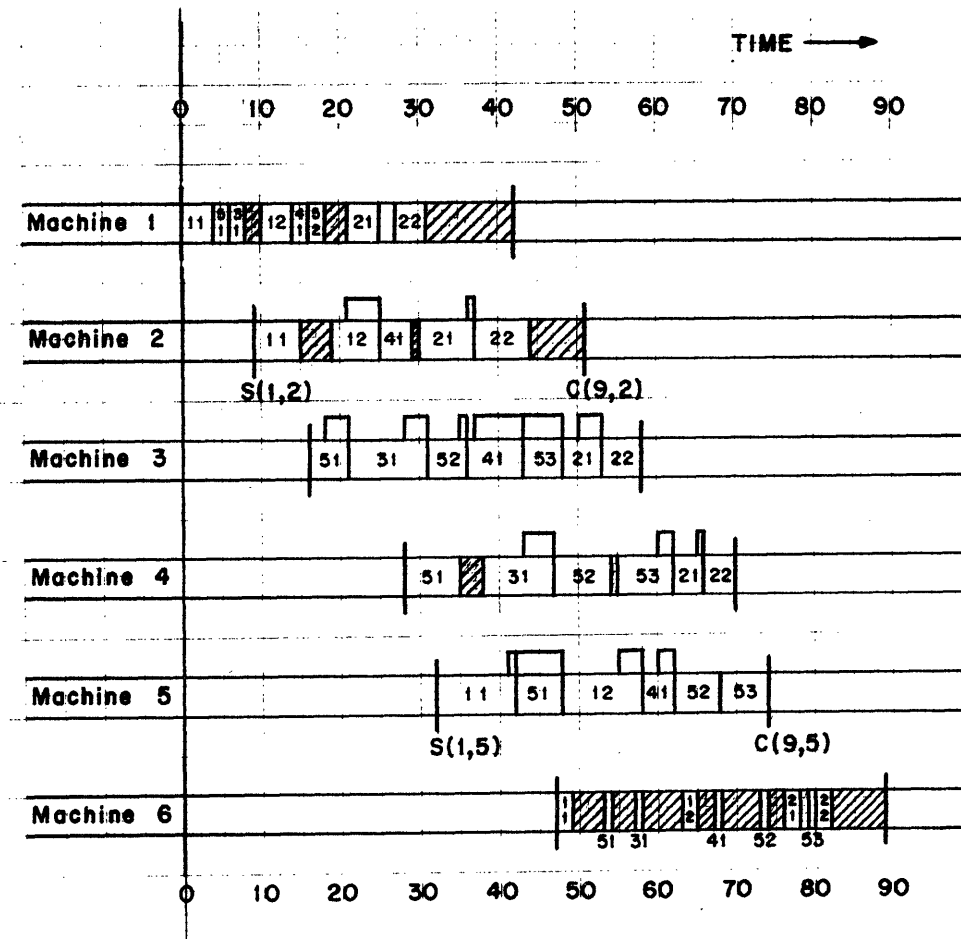
(b) Gantt Chart of Optimal Schedule

Optimal schedule $\sigma = \{(1,0), (5,4), (3,6), (1,10), (4,14), (5,16), (2,21), (5,25), (2,27)\}$. Rectangular blocks above machine bars indicate occupied buffer shaded areas are idle times in one period.

Figure 3.5 An Example of FFS Scheduling Problem

Hitz (1980)* describes an extension and refinement of the algorithm presented in his earlier report. The algorithm was implemented on a DEC 11/70 minicomputer and tested on an extensive range of problems involving six and eight machines, five part types, and between 15 and 25 items per period. The results indicate that in complex problems involving a diversity of machine routes and processing times, as well as very limited buffer storage, optimal schedules can be prohibitively time-consuming to find. However, even in such cases, consistently good suboptimal schedules can be found with computing times of the order of 20 - 30 secs, and such schedules appear to be considerably better than those obtained with simple myopic scheduling heuristics.

The results support the claim that for slow deterministic flexible flow shops with decentralized buffer storage, a control strategy employing implicit enumeration techniques to compute loading sequences not only for normal operation, but also for the recovery from disturbances, should be feasible and yield substantial benefits over simpler scheduling rules.

3.4 Flow Optimization

An important problem which has a fundamental effect on the production rate and utilization in an FMS is that of workpiece routing. If the production mix of parts is specified and the location at which all the operations can be performed is known, the optimal sequence of work station visits (the route for each of the parts) should be chosen. The common industrial practice is to route the parts in such a way that the workloads at the workstations are equal (Olker, 1978; Solberg, 1979). It is shown by way of an example in (Kimemia and Gershwin, 1980)* that this is not always the optimal policy. As indicated earlier in this section, the machine or job-shop problem has had considerable attention in the past (Coffman, 1976). Given a set of jobs each comprising of several specified tasks, and a set of machines, the optimal production schedule according to some criterion is computed. The computational requirements for solving job-shop problems grow rapidly with the number of jobs and machines (Section 3.2). The periodic scheduling algorithm (Section 3.1) is a heuristic method for evaluating schedules that maximize the production rate of an FMS. However, before the periodic schedule can be evaluated, the routing of all the parts must be established.

Extensive simulation studies of FMS's have been done (Hutchinson and Hughes, 1977; Lenz and Talavage, 1977). They allow detailed investigation of the effects of parameter variation and routing policies. Simulations can be costly in terms of computation, particularly when the number of options to be tested is large. Analytical techniques can reduce the cost by narrowing the number of options to be tested and also by allowing optimal operating policies to be chosen for each system configuration under test.

In Kimemia and Gershwin (1980)*, a network flow optimization approach is taken. Rather than analyze the movement of individual parts, the aggregated flow is considered. Network-of-queues analysis is used to account for congestion effects. It is assumed that the workstations are perfectly reliable and that they have infinite sized buffers.

Steady state network-of-queues models have been found to be in good agreement with the observed performance of an actual FMS (Solberg, 1979).

Workpiece routing is only part of a much larger decision making problem (Hutchinson, 1977). At the strategic level, the group of parts to be manufactured together is first chosen. Group technology (Houtzeel, 1979), which is a method of classifying parts by their processing requirements, is a useful tool and may in the future be part of an automated system of process planning.

Once the part mix is chosen, the configuration of operational capabilities at the workstations must be selected. In the metal cutting industry this involves deciding how all the tools needed by the parts should be distributed amongst the machining centers. This effectively defines the locations at which all of the operations can be performed.

After the part mix, system configuration and part routings have been chosen, the tactical problem of controlling the movement of individual workpieces remains. The flow optimization method produces the optimal flow rates of all the workpieces at all stages of their manufacturing process. The flow rates give the real time controller operating points which, if properly maintained, ensure a good overall system performance.

Kimemia and Gershwin (1980)* use a very simple scheduling technique to do this, and obtain excellent results. Even better results can be expected from the methods described in Sections 3.2 and 3.3.

At the design stage, analytic tools which enable the designer to study the effects of parameter variation on system performance are needed. Flow optimization provides a means of studying how such factors as routing, station processing times and operational configuration affect production rates and station utilizations. It is then possible to make trade-off studies among the various different designs available.

Modelling and Optimization of Flexible Manufacturing Systems

An FMS consists of M workstations producing P different part types (also called piece types). Each piece of type i requires K_i operations

for its completion. A particular operation can be performed at one or more different workstations. The time to complete operation k on a type i part at station j is a random variable with mean t_{ij}^k . An operation is composed of a set of simple operations, such as drilling tapping or milling, that are completed during a single workstation visit.

The most important variables in the flow optimization representation of a manufacturing system are x_{ij}^k , the flow type i parts through station j which are experiencing operation k .

An important performance measure is the utilization $u_j(x)$ of the workstations, which is defined as the proportion of time that a workstation is operating on a piece. The utilization is a function of the assignments $x = (x_{ij}^k)$ and is given by (Kimemia and Gershwin, 1980)*

$$u_j(x) = \sum_{i=1}^P \sum_{k=1}^{K_i} x_{ij}^k t_{ij}^k \quad j=1, \dots, m \quad (3.3)$$

The methods of network-of-queues analysis can now be applied so as to express other system performance measures as functions of x . Optimization problems are then formulated which maximize the production rate (or perhaps another index of performance) subject to constraints imposed by the structure of the system.

For an FMS modeled as an open network of queues, the following non-linear problem determines the optimal distribution of flows:

$$\text{maximize} \quad \beta_1 \sum_{i=1}^P \sum_{j=1}^m x'_{ij} - \beta_2 \sum_{j=1}^m q_j(x) \quad (3.4)$$

subject to

$$\sum_{j=1}^M x'_{ij} = \alpha_i \sum_{i=1}^P \sum_{j=1}^m x'_{ij}, \quad i=1, \dots, P \quad (3.5)$$

$$u_j(x) \leq 1, \quad j=1, \dots, m \quad (3.6)$$

$$x_{ij}^k \geq 0, \quad \begin{array}{l} i=1, \dots, P, \\ k=1, \dots, K_i, \\ j=1, \dots, m \end{array} \quad (3.7)$$

In this problem, P is the number of part types, K_i is the number of operations required by type i , and m is the number of machines. The quantity $q_j(\cdot)$ is a nonlinear function of the flows and represents the average in-process inventory at station j . The parameters β_1 and β_2 are specified weighting parameters to indicate the relative importance of keeping production rate high and in-process inventory low.

The parameters α_i are ratios, which indicate, through (3.5), the amount of production that is devoted to type i parts. These quantities are specified, and they must satisfy

$$\sum_{i=1}^P \alpha_i = 1 \quad (3.8)$$

$$\alpha_i \geq 0. \quad (3.9)$$

Note that when $\beta_2 = 0$, this is a linear programming problem.

Kimemia and Gershwin (1980)* show how the special structure of this problem can be exploited to produce an algorithm which appears to be computationally feasible for large systems.

Two-Machine Two-Part Example

As an example of the application of network flow optimization techniques to flexible manufacturing systems, consider the hypothetical two-workstation system of Fig. 3.6. The system consists of two similar machining centers each with a capacity of 60 tools. Two different part types are to be produced by the system. The first requires the application of 20 tools and the second requires 70 tools. (The two part types may use some tools in common.) Assume that half the tools for the second part type are loaded into the first station and the other half at station 2. All 20 tools for the first part type are loaded into both workstations.

The first part type can therefore be machined at either workstation while the second must visit both stations. The compound operation performed by the 35 tools at station 1 for part type 2 is labelled "operation 1" and the one performed by the other 35 tools at station

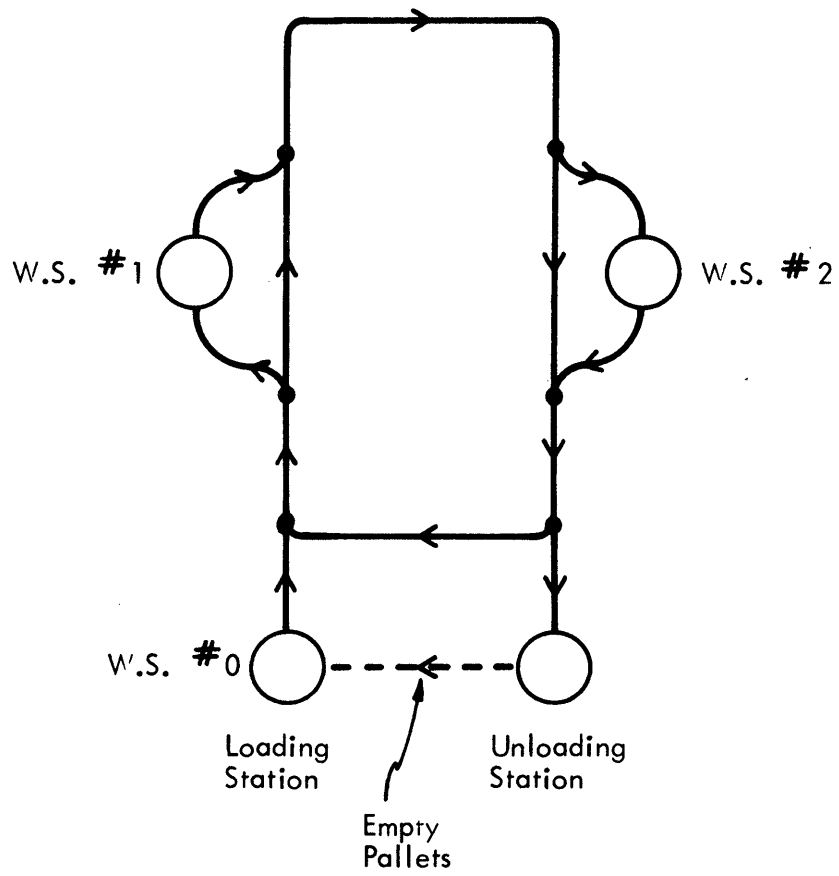

Figure 3.6 A Two-Workstation System

2 are "operation 2". Part type 1 requires only one operation, labelled "operation 1".

The ratio requirement is that two type 2 pieces should be produced for each type 1. This, $\alpha_1 = 1/3$ and $\alpha_2 = 2/3$.

Assume that the nature of the operations is such that the time that a workpiece spends at a station can be modelled as an exponentially distributed random variable whose mean ($1/\mu_j = t_{ij}^k$) depends only on the station index j . The random description of the operation may account, for example, for adaptive control systems at the workstations which continuously vary feed and spindle rates to compensate for tool and workpiece condition. It may also describe the random availability of the machines.

Define the vectors x_i , each representing the flow of type i parts, as: $x_i = (x_{i1}^1, x_{i2}^1)'$ and $x_2 = (x_{21}^1, x_{22}^2)'$. We can express any flow vector as a weighted sum of three vectors, each representing a unit flow rate into the system. They are $\hat{x}_1^1 = (1,0)^T$ (unit flow rate through station 1); $\hat{x}_1^2 = (0,1)^T$ (unit flow rate through station 2) for the first part type; and $\hat{x}_2^1 = (1,1)^T$, for the second. Any flow vector can be expressed as

$$x = \begin{pmatrix} w_{11}\hat{x}_1^1 + w_{12}\hat{x}_1^2 \\ w_{21}\hat{x}_2^1 \end{pmatrix} \quad (3.10)$$

with the appropriate choice of scalars w_{11} , w_{12} and w_{21} .

With these assumptions, the system can be modelled as an open network of queues. The average queue length at each station is the same as that of an isolated M/M/1 queue with the same arrival and service rates. The variables w_{11} , w_{12} and w_{21} are equal to the flow rates of the parts on each of the three available paths. Thus the arrival rate at station 1 is $(w_{11} + w_{21})$ and at station 2 $(w_{12} + w_{21})$. The average queue lengths can be expressed as a function of the w_i 's using the standard M/M/1 formula (Kleinrock, 1975).

$$q_1(w) = \frac{(w_{11} + w_{21})}{\mu_1 - (w_{11} + w_{21})} \quad (3.11)$$

$$q_2(w) = \frac{(w_{12} + w_{21})}{\mu_2 - (w_{12} + w_{21})} \quad (3.12)$$

The service rates of stations 1 and 2 are μ_1 and μ_2 respectively.

The optimization problem is to maximize the overall production rate while keeping the average in-process inventory below a set level Q . This is expressed as

$$\text{maximize } w_{11} + w_{12} + w_{21} \quad (3.13)$$

$$\text{subject to } q_1(w) + q_2(w) \leq Q \quad (3.14)$$

$$w_{21} = \frac{\alpha_2}{\alpha_1} (w_{11} + w_{22}) \quad (3.15)$$

$$w_{11}, w_{12}, w_{21} \geq 0 \quad (3.16)$$

This problem differs from (3.4) - (3.7) in that the limitations of queue size appear in a constraint (3.14) rather than the cost function. The behavior and numerical solutions of these two problems are similar, however. All other changes are simplifications that make use of the problem structure to reduce the number of variables and constraints.

The problem is solved here with $Q = 10$. The speed of μ_2 of workstation 2 is fixed at 5 pieces per hour, and that of μ_1 is varied from 2 to 10 pieces per hour. The results are compared to the asymptotic case when there is no limit on Q .

The proportion λ of type 1 parts sent to workstation 1 (referred to as the optimal split) is shown in Fig. 3.7 for $Q = 10$ and $Q = \infty$. The difference between the two is small. There are three operating regimes.

When μ_1 is small compared to μ_2 , the optimal split is zero and all type 1 pieces are sent to workstation 2. Similarly if μ_1 is large compared to μ_2 , the optimal split is unity and all type 1 parts go to station 1. This would indicate in this case that when the difference in

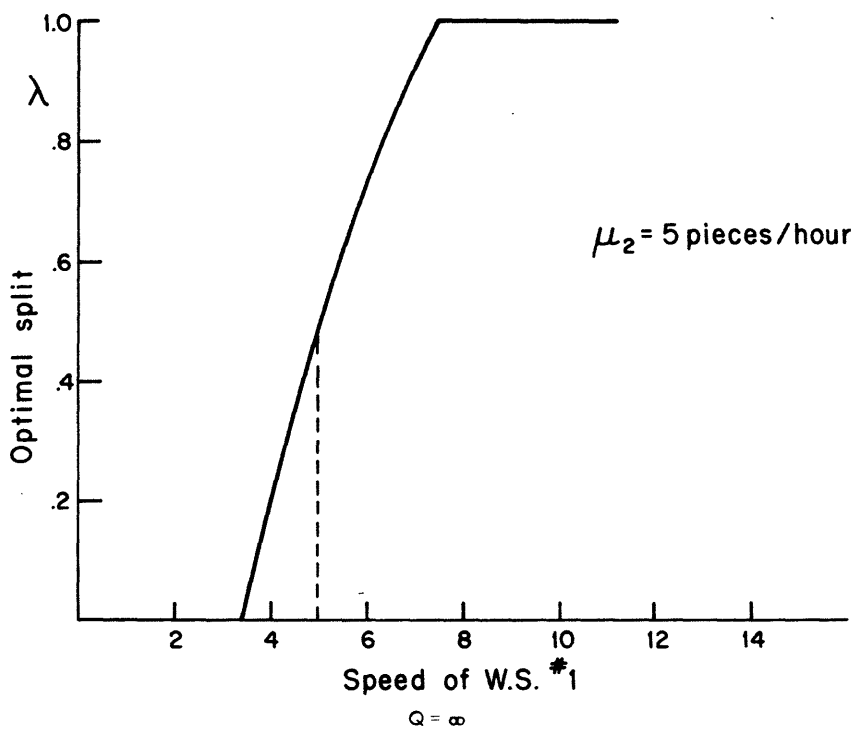
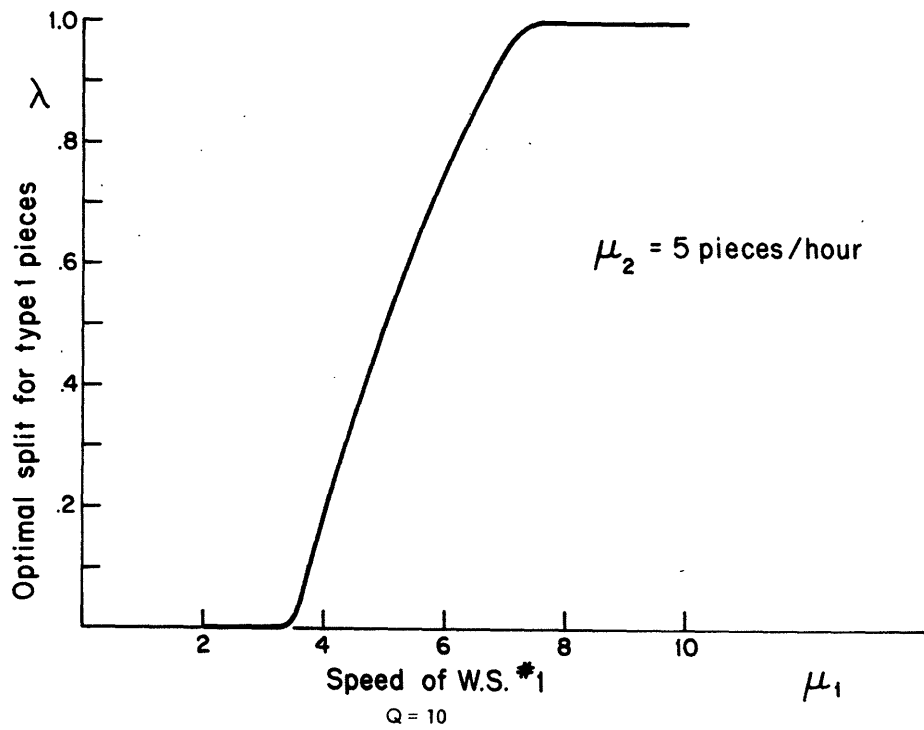

Figure 3.7 Optimal Split λ as a Function of μ_1

speed between the two workstations is great, it is not worthwhile making the slower station flexible. Even if it has the capability of performing operations on type 1 parts, it is not utilized. On the other hand, this flexibility may be valuable when the faster machine is unavailable due to a failure or to routine maintenance.

The range where μ_1 is about $\pm 40\%$ of μ_2 , the optimal split changes rapidly from zero at the lower speed to unity at the higher speed.

The three regions are evident in the effect on utilization and average queue lengths shown in Fig. 3.8 and Fig. 3.9. The change in the optimal split keeps the utilizations of the two stations close to each other. For this system, at least, the optimization produces approximately balanced workloads at the two stations when their speeds μ_1 and μ_2 are not widely different. When one station is much faster than the other, it is no longer optimal to have balanced loads at the two stations.

Research has been done on the economics of single operations and there are expressions that relate the cost of performing an operation at an isolated work-center to parameters such as feed rates (Halevi, 1980). The two-machine example shows that changing the parameters of one station affects the performance of the whole system. If tradeoff studies are to be made, it is important that each candidate configuration should have an optimal operational assignment, because otherwise the results would not be valid.

For example, if μ_1 can be set at either 4 or 6 pieces per hour, using a fixed value of $\lambda = .2$ would show the faster setting producing only a 6% improvement in the production rate. However, using the optimal values of λ ($\lambda = .19$ for $\mu_1 = 4$ and $\lambda = .75$ for $\mu_1 = 6$) shows the true improvement to be 22%.

Four-Machine Six-Part Problem

The flow optimization method can be applied to larger systems. Consider Table 3.2 which shows the operational requirements for 6 parts to be produced on 4 workstations. All operation times are deterministic. In this example, the total number of possible paths for all pieces is

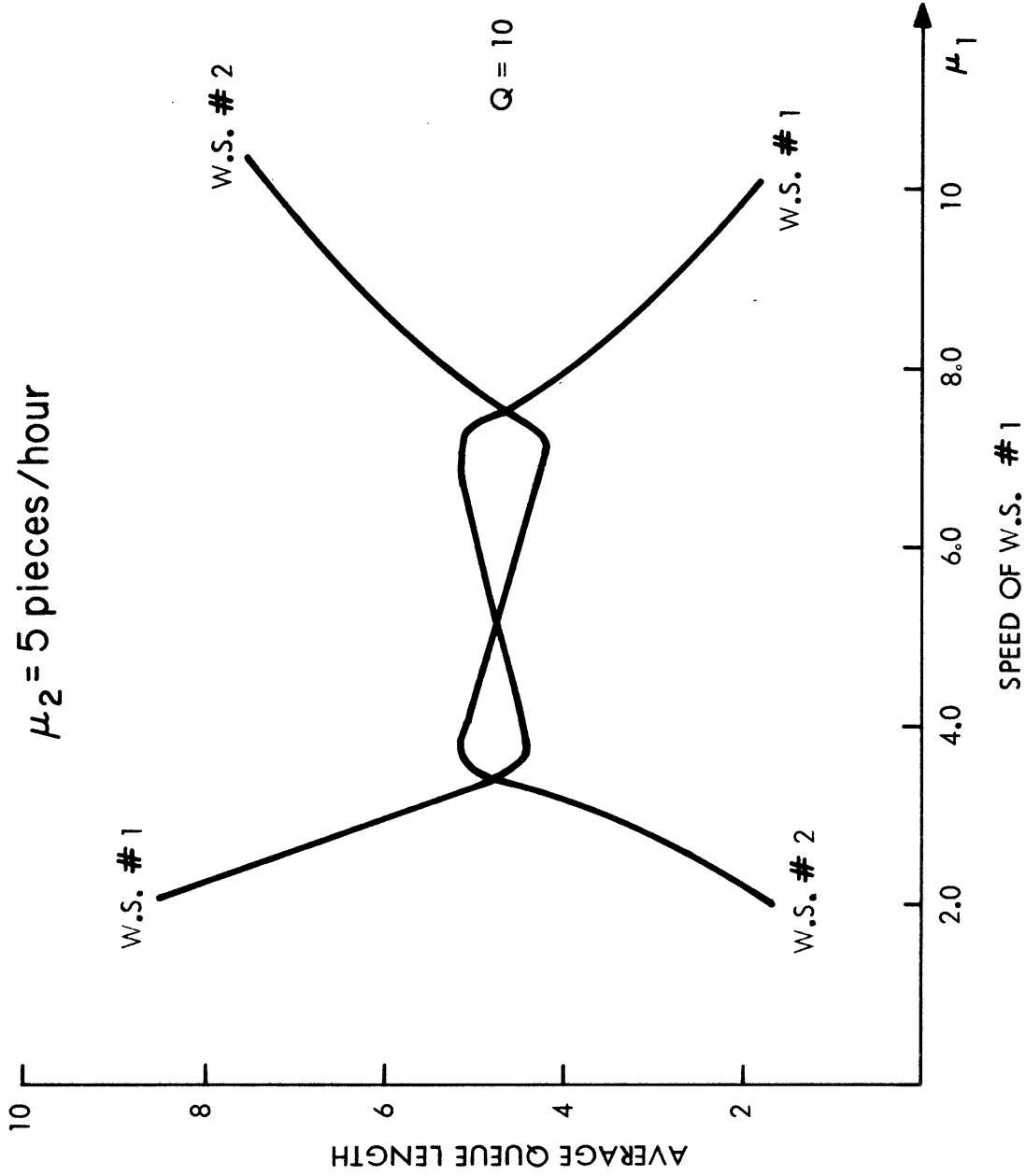

Figure 3.8 Optimal Average Queue Lengths as a Function of μ_1 with $Q = 10$.

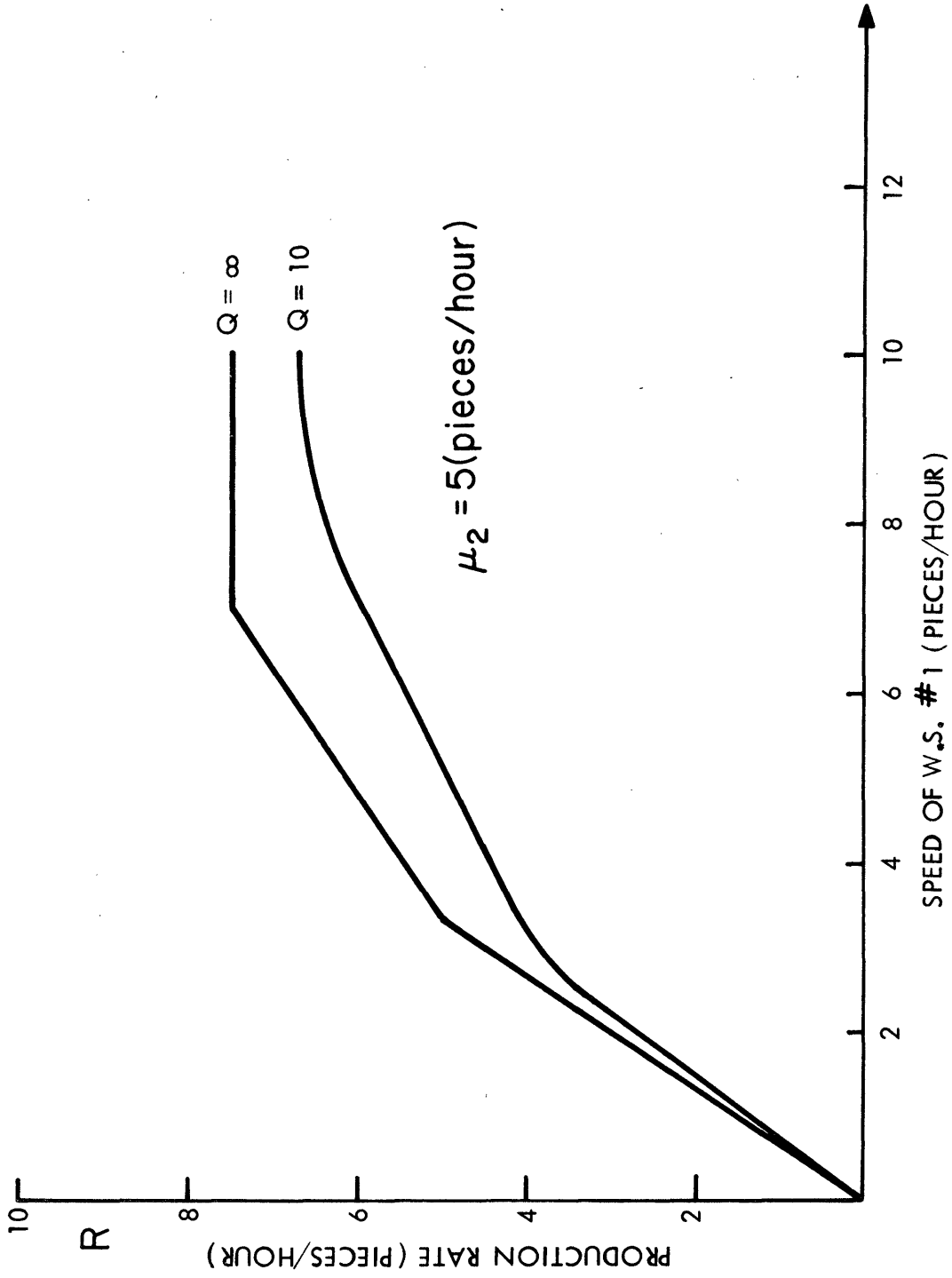

Figure 3.9 Optimal Production Rates as Functions of μ_1 .

k-operation \	1	2	3	4
1	0.95	1.0	1.1	1.0
2	5.9	4.8	5.6	6.0
3	3.5	3.7	3.2	∞

t_{1j}^k - part type 1

op-k \	1	2	3	4
1	3.0	3.4	3.2	3.9
2	2.0	2.8	1.9	2.8

t_{6j}^k - part type 6

j-workstation

k-operation \	1	2	3	4
1	3.9	4.2	4.1	3.6
2	2.9	2.7	2.3	2.5
3	1.0	0.9	1.1	1.1
4	5.4	6.1	5.6	6.0

t_{2j}^k - part type 2

j-workstation

k-operation \	1	2	3	4
1	∞	3.0	3.2	3.1
2	4.3	4.4	4.3	4.6

t_{3j}^k - part type 3

j-workstation

k-operation \	1	2	3	4
1	1.4	∞	1.4	1.6

t_{4j}^k - part type 4

j-workstation

operation \	1	2	3	4
1	2.0	2.9	∞	3.0
2	3.7	3.9	3.0	3.9
3	4.9	5.9	5.0	5.9

t_{5j}^k - part type 5

part	1	2	3	4	5	6
ratio requirement	0.2	0.3	0.1	0.1	0.1	0.2

Table 3.2 t_{ij}^k Matrices and Operational REquirements for 6 Part Example.

too large to be enumerated in advance as we could for the two-part problem above. Formulation (3.4) - (3.7) with $\beta_2 = 0$ produces a linear program with $56 x_{ij}^k$ variables. There are four inequality constraints and 15 equality constraints due to flow conservation and the ratio requirement.

The problem is solved by a standard linear programming code and the results implemented on a discrete simulation of an FMS (Kimemia and Gershwin, 1980)*. The results are shown in Table 3.3 and Fig. 3.10. In this example, few paths are required for the solution. Here, the optimal assignments lead to balanced workloads at the stations. Table 3.3 shows the routes and optimal flow rates for each of the six parts.

The results of Fig. 3.10 show the effect of implementing the optimal flow rates on a discrete simulation over 1500 time steps. This was accomplished by loading pieces at regular intervals onto each route (The length of the interval is equal to the reciprocal of the flow rate) so as to maintain the desired flow rates. This scheduling algorithm is not only simple to calculate, but is also easy to implement.

The production rate of the simulation is within 4% of that predicted by the optimization result. The optimal assignment satisfies all the workstation capacity constraints as equalities indicating full utilization of the stations. The simulation results show station utilizations ranging from .91 to .97. The differences between the simulation and optimization results may be accounted for by the initial transient period and because the simulation run starts with an empty system.

Also illustrated in Fig. 3.10 are the queue occupancies at the four workstations. They are most affected by the scheduling algorithm and do not enter into the linear optimization problem. It should be emphasized that in the simulation, there are no workstation failures and that all operation times are deterministic.

3.5 Summary

The research summarized here has been aimed at manufacturing systems in which routing and scheduling decisions are required in real time.

Results

Part	strategies	τ_{ij}	Operations Machine Total time	flow rate pieces/min	split
1				.06225	.65
				.03295	.35
2				.02813	.20
				.0856	.60
				.02913	.20
3				.04760	1.0
4				.04760	1.0
5				.04760	1.0
6				.09520	1.0

Production rate .4760

Table 3.3 Optimal Strategy Assignments

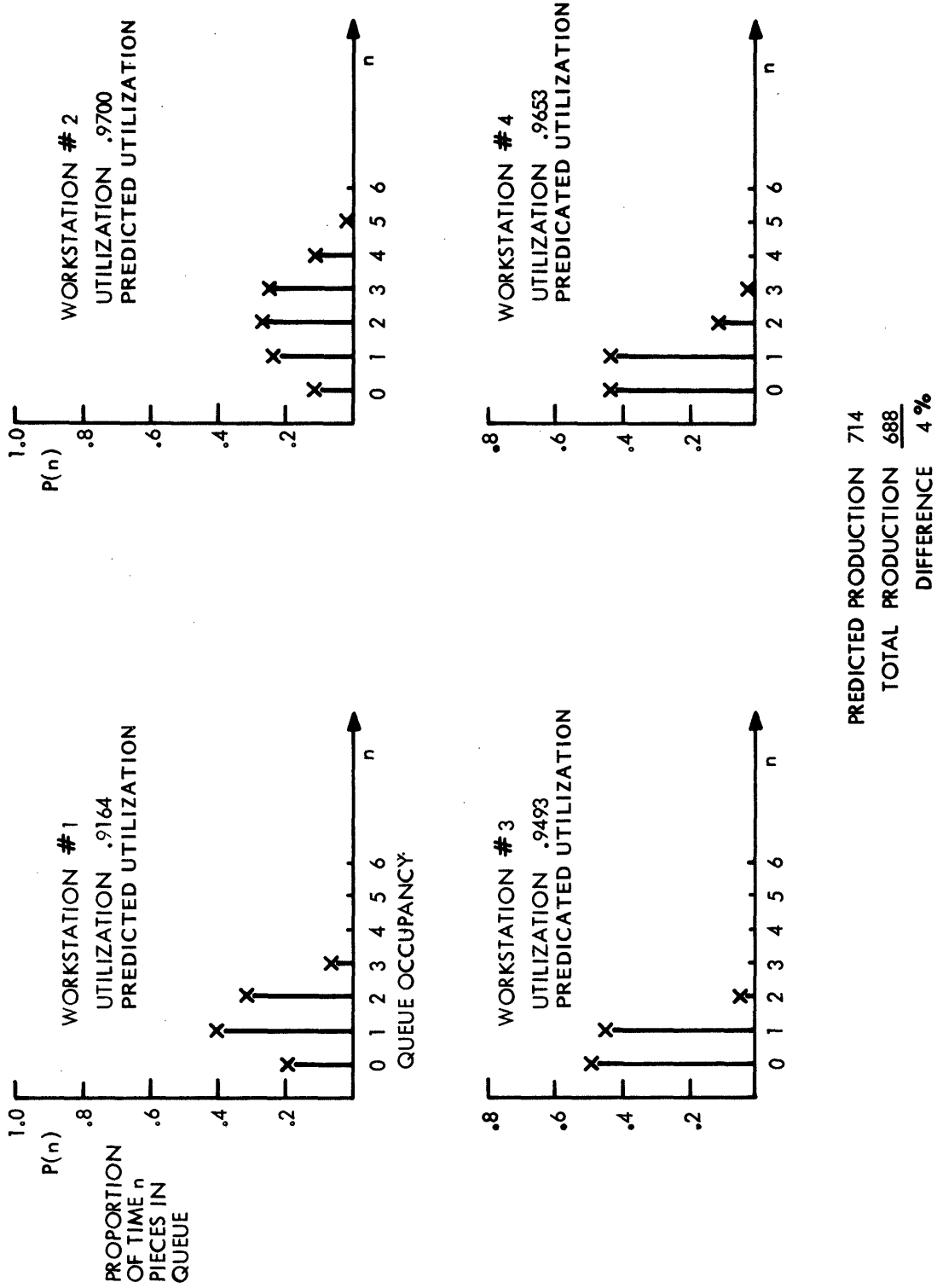

Figure 3.10 Queue Occupation for Four-Machine Six-Piece System

In Sections 3.2 and 3.3, individual parts and decisions are represented; in 3.4 they are aggregated into flows. A hierarchical approach to the planning and operating an FMS, based on these tools, is described in Section 3.4.

The problems described here lack one significant feature: they do not explicitly represent machine failures, such as are described in Section 2. The following section describes our efforts to synthesize these two areas.

4. SYNTHESES

Some of our current work is aimed at synthesizing the areas described in Sections 2 and 3. That is, we seek methods of controlling the movement of material in systems in which processing stages fail and buffers are finite. This control must respond to the current state of the system. That is, before any decision is made, it is necessary that the state of the system - the machine repair conditions and the buffer levels be known.

Alternate versions of this synthesis are under construction. Two (Hahne, 1980; Tsitsiklis, 1980)* seek the optimal control of the network in Fig. 4.1. Materials enter machine M_0 from the outside. A process takes place, and the material can then be routed to buffer B_1 or buffer B_2 . After buffer B_i , material goes to machine M_i , $i=1,2$, and then it leaves the system.

The three machines have exponential failure and repair distributions, and the buffers have finite capacity. The models differ in that one has discrete material and machines with exponential processing times; the other has continuous material.

Preliminary results from the discrete case are presented in Fig. 4.2. It should be noted that no decision is necessary, or even meaningful, if machine M_0 is under repair, or if it is blocked. Consequently only the part of the state space where M_0 is operational ($\alpha_0 = 1$) is shown, and when the buffers are full ($n_1 = N_1 = 6$ and $n_2 = N_2 = 6$), a null decision (0) is indicated.

Each point in Fig. 4.2 represents a value of the state in which M_0 is operational. As before $\alpha_i = 1$ means machine i is operational and $\alpha_i = 0$ means it is under repair. The number of pieces in buffer i is n_i .

There are two kinds of states for which decisions are meaningful: those for which the optimal decision is B_1 and those for which it is B_2 . The two sets are indicated in Figure 4.2.

Current effort is aimed at developing numerical techniques for generating optimal decisions as well as understanding the qualitative

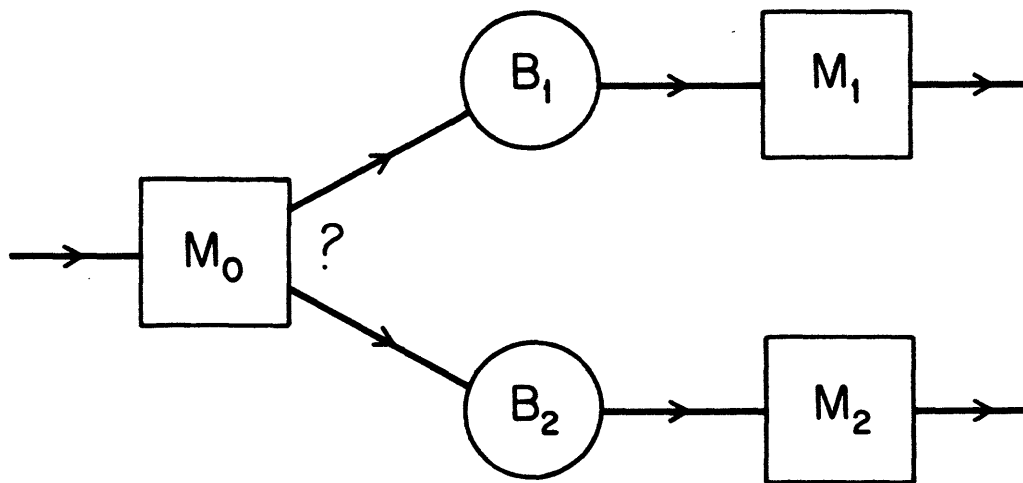

Figure 4.1 Small Decision Network

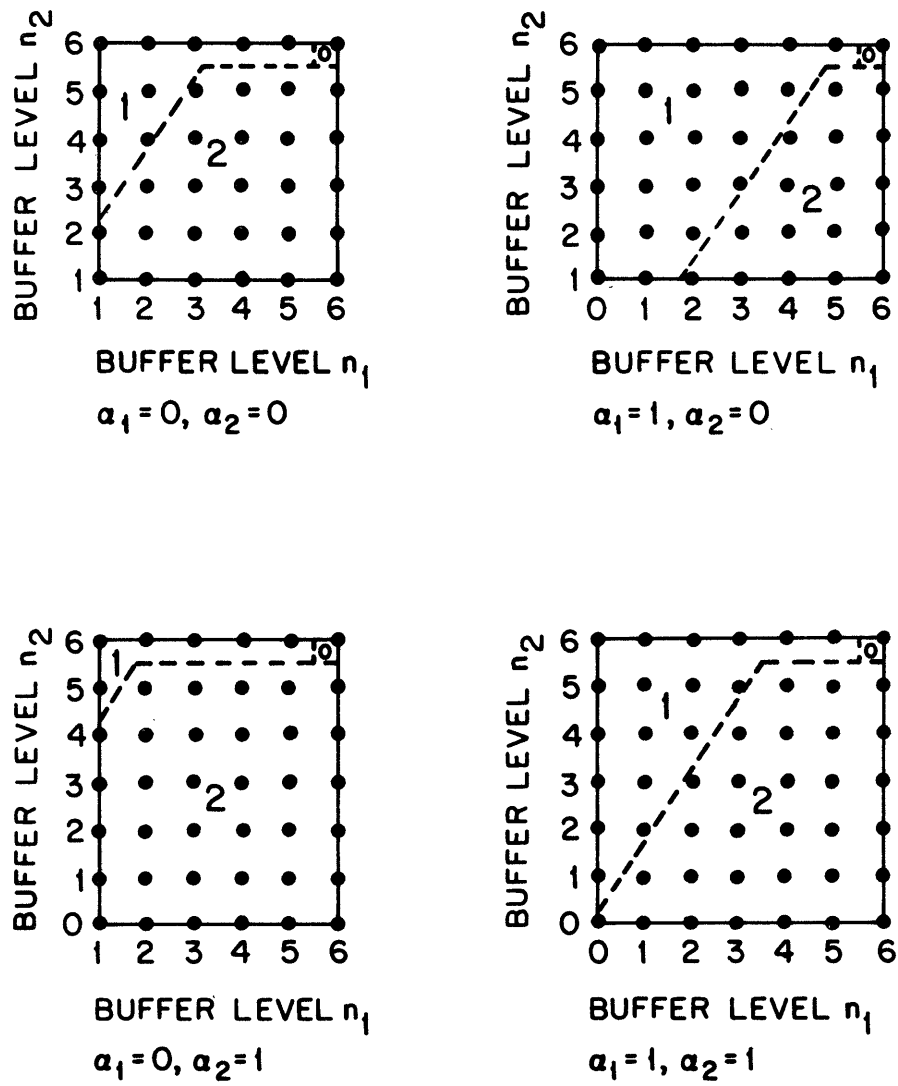

Figure 4.2 Preliminary Results from the Discrete Decision Network

behavior of these problems.

Related work currently in progress is a study of the hierarchical decision structure mentioned in Section 3.4. It is hoped that the flow optimization technique can be extended to include a representation of failures.

5. PLANT VISITS

A. Introduction

Under the current and preceding grants, the project team has endeavored to maintain contact with appropriate industrial organizations. In early 1976, before Grant APR76-12036 was initiated, a number of companies had been identified that we felt would possibly be interested in interacting with the project. The list was selected from personal contacts, known activities or interest in applying flexible automation to batch manufacturing, and consultation with the M.I.T. Industrial Liaison and M.I.T. Associates programs which have working relations with almost 200 companies in the U.S. and abroad. An initial group of 16 companies was chosen, representing a broad spectrum of metal-working machinery, consumer and military electro-mechanical products, electronic assembly and miscellaneous specialty products, and a formal inquiry was sent to the manufacturing administration of each one soliciting comments on the proposed research, and an expression of interest in active interactions. Eight of the 16 companies responded favorably, in some cases enthusiastically:

Kingsbury Machine Tool Corporation

The Raytheon Company

Xerox Corporation

AMP, Inc.

General Motors Corporation

Kodak

USM Corporation

Digital Equipment Corporation

As soon as the grant was under way, a program of initial visits to each of these companies was started. The purpose of the initial visits was to review the goals of the project and work under way with company personnel, to see and discuss manufacturing operations that the company felt might be impacted by flexible automation, and to discuss what the company felt were critical problems in manufacturing that needed to be solved in the future. Of particular interest to the M.I.T. group in these visits were such topics as: materials handling, scheduling, in-process

inventory, inspection philosophy, and overall planning. More detailed visits were anticipated later as data needs in process modelling and analysis were identified.

Under Grant APR76-12036, from August 1976 through July 1978, project members made a total of 16 plant visits, as follows:

Kingsbury Machine Tool Corp., Keene, N.H. (two visits)
 Raytheon Company (Office of Manufacturing), Lexington, MA
 Raytheon, Marine Division, Manchester, N.H.
 Sunstrand Corporation, Rockford, IL
 Raytheon Missile Division, Andover, MA
 Xerox Corporation, Rochester, N.Y.
 Raytheon Data Systems, Norwood, MA
 General Motors Technical Center, Dearborn, MI
 Electronic Associates, Inc., West Long Branch, N.J.
 AMP, Inc., Harrisburg, PA (two visits)
 General Telephone & Electronics, Waltham, MA
 Scott Paper Co., Philadelphia, PA
 AMF Harley-Davidson, York, PA
 AVCO Corporation, Lycoming Div., Williamsport, PA

Since July 1978, four additional visits have been made under the follow-on grant, DAR78-17826:

Sunstrand Aviation Division, Rockford, IL
 Kearney and Trecker, Milwaukee, WI
 Kingsbury Machine Tool Co., Keene, N.H.
 Pratt & Whitney Aircraft, East Hartford, CT

Almost all of the visits have been documented in detail for internal use in the project and some have been described in interim progress reports distributed to the project mailing list. In what follows, these 20 on-site interactions with 17 companies are briefly summarized, and other forms of interaction are listed.

5.1 Kingsbury Machine Tool Corporation, Keene, N.H.

Our host at Kingsbury on September 1, 1976, was Robert H. Eisengrein, Manager of Systems. M.I.T. attendees were M. Athans, J.E. Ward, and P. Kanellakis. Kingsbury makes a broad line of multi-head, fixed-tool machines in both transfer line and rotary dial configurations, and has

recently gone into multi-part dial machines and automatic assembly machines. Discussions centered on both Kingsbury's own manufacturing activities in making its product line, and on possible trends in new machine configurations.

Kingsbury's own manufacturing is vertically integrated, including their own foundry in the same plant. Although many common parts are produced each year (a modular design approach is used), quantities are such that production is entirely on a batch basis. Facilities include a mixture of N/C machining centers, general-purpose tools and multi-tool machines (i.e., gang drills). Some of the latter have low utilization, but have long since been written off. The number of parts in process (sitting around the factory floor) was quite large, perhaps typical of a batch-machine shop.

Kingsbury generates about 30,000 new part drawings per year, each of which has to be processed by manufacturing methods to develop routing and schedule sheets. An effort was launched in summer, 1976, to part-code, using a group technology system, both to eventually filter out redundant new designs and to reduce the manufacturing methods work on new parts types by taking advantage of routing/scheduling information already developed for similar parts. At the time of our visit, about 1000 parts had been processed, and the number of codes seems to be asymptotically approaching about 40% of parts processed, indicating that less than half of the part types are functionally different from a manufacturing process viewpoint.

The bulk of the metal-cutting machines that Kingsbury makes are "hard" automation; i.e., they are transfer lines configured and tooled for high-volume production of a single part type, using a number of simultaneously acting multi-spindle heads. Either linear or rotary machine configurations are used, depending on the circumstances or the wishes of the customer. In these machines, the parts are passed (indexed) from station to station, and operations are performed in parallel at all stations by moveable tool heads.

We were shown two different transfer line systems being assembled for two different auto makers, both to make carburetors. One was an in-line (linear) system in three separate 80-foot sections and the other consisted of three separate rotary index (dial) machines. In the linear machine,

pallets carrying the parts are indexed from station to station by an oscillating transfer bar which runs the length of the machine. At the end of each advance cycle, the pallets are pushed up off the bar and clamped under the work table for machining. During machining, the bar retreats one station in preparation for the next advance cycle. The one section of this line that we examined had 80 stations, not all of which had tool heads (no-op stations are left for later additions to the machining operations performed, or where the extra space is needed for angled heads at a particular station). Each of the three sections of the line operates independent of the others and is fed from its own overhead parts hopper and spiral gravity track. Index time for each section is about seven seconds. The rotary system, which had just completed final factory tests and was about to be shipped, seemed to take up a lot less floor space although the number of operations was presumably about the same. In the rotary machines, the parts are carried from station to station by the rotation of the machine table.

We also saw a very complex rotary dial machine that assembles three pinion gears (plus their shafts, washers and locking pins) into a planetary carrier. This subassembly for an automotive transmission is produced at a rate of 4,000 assemblies per hour. About half of the workstations were concerned with checking that parts were correctly oriented, that the shaft holes were present, etc.

A followup visit was made to Kingsbury on April 3, 1978, by five project personnel. S.B. Gershwin, J.E. Ward, K. Hitz, Y. Horev and J. Kimemia met with Mr. Robert H. Eisengrain; topics discussed included a brief review of a conceptual design for a loop-type flexible machining system that Kingsbury is discussing with potential customers, a flexible palletized rotary index machine, a carousel-type assembly machine, and discussion of the availability of reliability data for machines in factory service.

Recently, Kingsbury had introduced a new machine configuration, the 600 series, which provides flexibility. This is a rotary machine with multi-spindle tool heads (eight, typically), but there is only a single spindle motor and only one tool head is in operation at a time. Also, the workpiece is at a fixed location and is fed in and out to perform cuts. (It may also be rotated between cuts to present various surfaces.) A two-part

configuration which we saw makes either half of a large gearcase at the flip of a switch. Mr. Eisengrein said that he expected more demand for this sort of flexibility in the future -- i.e., machines possessing the production capacity advantages of multi-spindle heads, but not dedicated to one part. He felt that the single-spindle capacity of most N/C tools limits their applicability to special or low-volume situations.

The 600 series is best adapted to boring/drilling/reaming/tapping operations. Limited surface milling is possible, but only on surfaces parallel to the in-out feed, unless a work holder with a three-axis translation capability is used (basically another machine). Kingsbury feels that it is better to perform such operations on a separate N/C miller and use the 600-series machines only for the multi-spindle operations to which they are best suited. Thus has arisen the concept of a flexible loop-type system incorporating both N/C millers and 600 series machines.

One proposed configuration that has been discussed with potential customers has a single pallet conveyor loop serving eight machines; four N/C millers and four 600 series. The machines would all be on the inside of the loop, permitting a common store of tool heads for the 600 series machines and interchangeability of heads among them. On one specific set of about 15 part types studied, the system would have enough in-place tool heads to handle about three part types at a time without tool-head changes. Mr. Eisengrein said that he was most interested in the applicability of our modelling techniques to the analysis of the operation of this type of system.

We also saw a flexible rotary dial machine, just being completed for a customer, in which parts were fixtured on pallets and the tool-head motions were selectable from a set of pre-programmed operations. This machine will make any of 17 different parts requiring some combination of boring, facing and drilling, but it was not clear whether all of these parts could be made with the same set of tool heads. The parts seen on fixtured pallets were iron castings that were portions of compressed-air manifolds, some with end flanges, some with side flanges.

We also visited the Kingsbury Assembly Machine (KAM) division, located nearby. During a brief tour of this facility, we saw a carousel-type machine for assembling and pressure-testing relief valves and a machine for simultaneously installing brass fittings on both ends of short hydraulic hoses (length-adjustable by controlling the separation of the two halves of the machine).

An observation is that assembly machines as presently designed tend to be single-purpose because of the specific tooling and operations sequences required; also, each feeder for a component part can handle and orient only parts of that specific geometry. Although such dedicated machines could, of course, be included as stations in flexible machining and assembly networks in the future, it is unlikely that all the component parts would be made in the same system. Many parts used in assemblies are small standard hardware items such as pins, screws, washers, etc. or are specialty items (bearings, etc.) purchased from an outside vendor. Another factor is that machined parts are usually deburred before assembly an operation often requiring lengthy tumbling (periods of hours) of batch lots of the same part type, and perhaps manual operations for critical internal edges. More flexible assembly techniques using robots are on the horizon, but their interconnection with machining networks may be a long way off, for the reasons stated.

A third visit with Mr. Eisengrein at Kingsbury took place on November 15, 1979. Participating were J.E. Ward and five students: E. L. Hahne, M. H. Ammar, L. Ekchian, M. M. Ibrahim and J. Kimemia.

Mr. Eisengrein spent some time describing the current types of transfer-line machines that Kingsbury is building for customers, both in the areas of metal-cutting and automatic assembly. He mentioned that the trend is away from long, synchronous machines to asynchronous machines made up of a number of independent sections separated by buffers. Various companies using the older synchronous machines with many stations (up to 500 or more) have found it difficult to keep such lines producing more than about half the time. Typical downtimes for one cause or another vary from 30 to 60 percent of shift time, on the average.

Breaking such long lines up into smaller sections separated by buffers (float banks) can easily raise productivity by 20 percent or more, since a failure in one section does not prevent other sections from continuing to operate so long as buffer capacities permit. During our later plant tour, we saw several transfer lines being constructed that were broken up in this way.

Mr. Eisengrein expressed continuing interest in our work on the effects of buffers in transfer lines and flexible systems, and supplied us with data on reliability experience for one of their machines that had been equipped with a monitoring system in the customer's plant. He also described an innovative combination machining and assembly system specified by a particular customer, and that they were in the process of bidding on. This system would have parallel machine lines converging on a single multi-station assembly machine. The customer was specifying buffers in all transfer paths between machines.

5.2 Raytheon (Headquarters, Lexington, MA).

The initial meeting at Raytheon on October 22, 1976, was with Mr. Frank H. McCarty, Corporate Director of Manufacturing Engineering, and a number of associates. Mr. Robert L. McCormack, Vice President of Manufacturing, and Mr. William M. Pease also attended, part-time. The M.I.T. attendees were: L. A. Gould, S. B. Gershwin, J. E. Ward, and P. Kanellakis.

Mr. McCarty described the activities of the various Raytheon divisions and suggested that four of them would be of interest to us: Marine Products (Manchester, N.H.), Missile Systems (Andover/Shawsheen, MA), Raytheon Data Systems (Norwood, MA) and Caloric (Topton, PA). These cover a broad spectrum of product types and manufacturing volume. Mr. McCarty's group interacts with the various divisions on manufacturing problems, design of new facilities and considerations of manufacturability in design of new products. Regular Manufacturing Council meetings are held with representatives from corporate and division groups responsible for manufacturing engineering, advanced methods (new materials and processes), and plant engineering. Mr. McCarty offered to make all arrangements with his counterparts in these divisions.

5.3 Raytheon - Marine Products, Manchester, N.H.

Our host at Manchester was Jean E. Rheaume, Manager of Industrial Engineering/Plant Engineering. Other Raytheon personnel were Mr. Frank McCarty of Lexington, and Jack Doran, Manager of Industrial Engineering, Missile Systems Division (Andover, MA). M.I.T. attendees were: M. Athans, L. A. Gould, N. H. Cook, J. E. Ward, and S. B. Gershwin. The visit included a complete plant tour.

Manchester produces some 470 products, with 500 to 5000 annual volume being typical of most catalog items. These include radars, depth sounders, power supplies, and marine radios, all primarily electronic in nature. The facility fabricates all sheet metal, all magnetic components, and PC boards in-house. Most PC-board component insertion is by hand, although one small semi-automatic IC (integrated circuit) inserter was in use. The facility is fairly compact and there seemed to be vast quantities of work in progress (batch lots) stored just about everywhere. Some lazy Susan assembly tables were in use; long push-along assembly tables were also available, but not in use at the time of the visit. In the sheet metal shop, an N/C punch press is used to nibble-cut all panel openings, replacing other types of machining that would normally be necessary. Electronic testing is largely automated, using both commercial testers and units of Raytheon's own design.

5.4 Raytheon Missile Systems (Andover, MA)

The Missile Systems Division was visited January 19, 1977 by M. Athans, J. E. Ward and S. B. Gershwin. Mr. Jack Doran, Manager of Industrial Engineering, was our host and Messrs. Frank McCarty (Lexington) and Frank Moscuza (Manufacturing Engineering, Raytheon Data Systems) were also present. The primary product of the Andover facility at the time was the Hawk Missile system; the missiles (about 15/day) and some parts of the ground system, although the facility was gearing up for the larger Patriot missile. All metal fabrication and radome construction was performed at the Shawsheen plant a few miles away; both facilities were toured.

At the Shawsheen fabrication facility, we were joined by Mr. Jerry Bellmore, Floor Support Industrial Engineer, who has a staff of 19 people handling day-to-day production problems on the floor, and who interacts with the process planning group (24 people). Batch sizes released are typically one-month's requirements and typical flow-through time is six months from release to completion; i.e., parts for a half-year's production are on the floor at any

time. A number of N/C machining centers were being used plus many standard general-purpose tools and a number of dedicated, multi-spindle machines set up for particular operations. In some cases, one operator takes a batch down a line of dedicated machines, completing all parts in the batch on one machine before moving to the next one. These are generally older machines for which utilization is not so important. Many machines seemed to be idle, and it was learned that the machinist/machine ratio is about 0.7 at the present production level. Typical changeover time for a machine from one part to another ranges from one to six hours. Great emphasis is placed on scrap rate because of the value of the parts, and problem areas are quickly pinpointed by Mr. Bellmore's group for attention.

All electronic fabrication and mechanical assembly is performed at the modern Andover facility, which is quite spacious and well laid out. Most of the brief time available to us was spent in the circuit board area, where automatic insertion machines are used for both ICs and axial-lead passive components. (There is, however, still a lot of hand component-insertion for components that the present machines cannot handle.) Many assembly jobs are stored in "kit" form (all the parts for one assembly) and drawn out to be worked on, then returned to stores to await other operations.

5.5 Raytheon Data Systems (Norwood, MA)

Our hosts at Raytheon Data Systems, March 27, 1977, were Mr. Frank Moscuzza, Automated Manufacturing Planning, and Chuck Emory (Manufacturing Manager and Materials Manager). M.I.T. personnel were: J.E. Ward, S. B. Gershwin, L. A. Gould and A. W. Drake. The products manufactured are primarily computer terminal systems, consisting of a central controller and associated input-output stations plus some minicomputers of Raytheon's own design. No metal fabrication is performed in-house, so the operations are entirely printed-circuit board fabrication and assembly, electromechanical assembly, and test.

Approximately 450 large PC boards with about 200 ICs are produced per day. Automatic insertion machines handle much of the IC insertion; the remainder of the ICs and passive components, such as resistors, capacitors, coils, connectors, etc., are inserted manually. The normal lot size is 200 boards of a type, and a line is dedicated to one type of board at a time. A kitting section prepares parts bins and production aids for each run ahead of time, so that a fast line changeover can be achieved.

Scheduling and inventory-control problems were discussed. System delivery times were running about 60 days at the time of the visit and their goal was to get this down to 30 days (a plant expansion was under way). Mr. Moscuza was particularly interested in improving the materials-handling situation; material was making many trips in and out of various in-plant storage facilities. He was planning to eliminate the incoming storage facility by moving material directly from incoming inspection to the operating area where it was due to be used, and pacing vendor deliveries to limit the amount of on-line storage space required. At the time of the visit, a four-week piece part inventory was being maintained (16 weeks is a typical order lead-time for such parts) and a one-week inventory of large discrete items, such as cabinets, power supplies, etc., that take up a lot of space. The latter is controlled by contracting with suppliers for staged deliveries on an on-call basis.

5.6 Xerox Corporation (Rochester, N.Y.)

On January 24, 1977, J. E. Ward visited Xerox and met with: Mr. W. Robert Fischer, Manager, Manufacturing Research and Technology; John Gosztyla, a Xerox engineer, and Tod Kayama, a resident liaison engineer from Fuji-Xerox in Japan.

Initial discussions were on a general level about our work and goals, about present Xerox manufacturing operations, and automation directions that Xerox sees in the future. In this regard, Messrs. Gosztyla and Kayama described a study they have just started on the cost of making certain classes of parts, and of the economies that might be obtained in the future by some combination of changes in materials, redesigning to aid fabrication, new manufacturing methods, etc. Their starting point was aluminum castings, of which there are 30-odd in each Xerox machine, and which Mr. Fischer felt represented a growing problem in Xerox manufacturing operations. He said that parts take several weeks to flow through the manufacturing operations, and that he would like to reduce this in-process inventory, both because of the cost involved in the in-process material and because of the obsolescence factor when design changes are made.

Mr. Kayama briefly described a flexible N/C machining system that has been in operation at Fuji-Xerox in Japan since 1973. This system, developed

by Toyoda Machine Works, Ltd., incorporates five DNC machining centers (four single-spindle types with 40-tool magazines and one ganghead type automatically changing among 48 different gangheads with up to 20 spindles each), all interconnected by a loop-type pallet conveyor system. By the end of 1974, the flexible DNC line was machining total requirements for 13 different aluminum castings at considerable savings in manpower.

There are three different assembly buildings in Rochester, each dedicated to certain models, and one large metal fabrication shop that does all sheet metal and machining work. The metal shop and one of the final assembly buildings were toured. All electronic fabrication and sub-assembly (circuit boards, etc.) is done in the El Segundo, California, plant.

A large part of the fabrication activity concerns sheet metal parts, which have very close tolerances because of the optical nature of a copier. For example, a typical flatness requirement on a stamped machine base-plate (about 24 by 50 inches) is 0.004". Two Unimate robots are installed in the press area, making such large sheet metal parts, each feeding two presses. The robots were justified on the basis of safety in press loading, and reduction in press personnel; such large sheets require two people in hand-press loading. On the general question of robots, Mr. Fischer said he felt that a robot could be justified whenever its capital cost was less than four man-years' labor cost. He said robots are most likely to be slower than humans doing the same job, but make up for this in working continuously without break.

A large number of N/C machines were in use, several with pallet changers for setting up a new workpiece while the previous one is being machined. There were also several shuttle lines interconnecting up to three multi-spindle machines for sequential operations on large parts. These are "hard" automation transfer lines using conventional machine tools, and the setups (machine tools and tooling) are changed from time to time as models change in the Xerox line of copiers; one setup was just being torn down.

Xerox also has two specially designed transfer lines. One of these, designed by Xerox and built by Kingsbury Tool Company, is a 15-station machine that performs some 200 drilling and facing operations on a particular casting. Changeover for another part would be a lengthy process. The other transfer machine is of more conventional type and seemed to have more flexibility, but was not examined in detail. One "hard" automation system involving a number of interconnected machines produces a five-part assembly from raw bar stock at very high speed. The assembly is a paper-feed roller that is required in very high volume -- 17 are used in a typical copier -- and consists of a steel rod, about 3/8 inch in diameter and 20 inches long, with four grooved aluminum rollers one inch in diameter by one inch long staked along it at 4-inch intervals.

Also visited was the flexible automatic fabrication/assembly line acquired in 1976 to produce the family of diffuser rolls used in Xerox copiers. This machine consists of six operational stations performing boring, assembly, brazing, turning/grinding and broaching operations, a non-synchronous loop conveyor (about 20' by 150') and three parts-transfer robots. The conveyor line does not connect to any of the stations, and parts are transferred between the line and the workstations by the robots. Each robot has its own control system and serves two stations. The diffuser rolls in the parts family are all of the same configuration -- a cylindrical tube with two brazed end caps (with bearing journals) -- but vary in length and/or diameter, and the various sizes are handled automatically. Each of the stations (three of which are of CNC type, and the robots operates independently under its own control system) but all operations are coordinated by a master programmed logic controller (PLC).

The assembly area visited was that for the large-series copiers. The machines are assembled on dollies that are pushed from station to station on the final assembly line. Sub-assemblies are produced in side areas in batch mode with workers moving from one area to another to work on different sub-assemblies in sequence. There were no automated operations in the assembly area.

5.7 Sundstrand Machine Tool Corporation, Belvedere, Illinois

N. H. Cook and J. E. Ward visited Sundstrand on December 2, 1976, and met with: Mr. Dave Hutchinson, General Manager; Mr. Charles Reynolds, Supervisory Applications Engineers, Mr. Mike Davis, Chief Engineer, Mr. Gary Hunt and Mr. Thomas Shifo, Sales Manager. The primary interest in this visit was to see and discuss the new Sundstrand Pallet Shuttle System, a standard product offering derived from the earlier Sundstrand shuttle system installed at the Caterpillar Tractor Company. The major difference between the systems is that the former purchased shuttle car has been replaced by one of Sundstrand design and construction. Features of the new car are a positive rack-and-pinion N/C drive with 0.0005" accuracy (using an on-board LSI-11 computer), a redesigned cross shuttle mechanism that can turn end-for-end and thus does not require the car to move between removing a finished part from a machine and loading a new part, and an overhead trolley with time-division multiplex communications. The earlier car operated on a raised track which formed a barrier the length of the system, and had connections beneath the car where they were subject to contamination from dirt and chips. Also, some time was lost in properly aligning the car at each stop because the control was not as precise.

After visiting the prototype system and seeing a demonstration of the shuttle-car operation, some time was spent in discussion of flexible machining systems. The present system is designed for large parts (up to a 36-inch cube, weighing up to 20,000 pounds), which typically have 20-45 minute cycle times once loaded into an N/C machine tool. Each part, mounted on a pallet, resides in a tool, on the car (one of two cars if it's a large system), or at a load/unload station -- thus the car(s) must have enough time to visit stations in the sequence necessary to keep all machine tools busy. It was stated that cycle times less than about 10 minutes would cause problems in keeping machines fed with new parts and that jobs had to be laid out to avoid such a short cycle time for any machine. One possibility, if parts are small, is to fixture two or three on one pallet. The question of buffer queues at machines (there are none now) was discussed and it was stated that this is generally too expensive to implement, requiring basically a pallet changer (similar to the one mounted on the shuttle car) at each tool.

Sundstrand would probably use a powered, free conveyor for smaller scale machines with short cycle times.

Some general ideas of cost (in 1976) were obtained. The car system costs about \$300,000 and pallets about \$6,500 each. Including system layout and installation charges of about \$450,000, a system with six \$400,000 machining centers would cost about \$3,250,000. Fixed costs per part were also discussed: including jigs, fixtures and part programming, an average figure is \$60,000.

5.8 General Motors Technical Center, Warren, MI.

M. Athans visited the General Motors Technical Center on March 28, 1977, and met with Frank Daley, Director, Manufacturing Development, Richard C. Beecher, Department Head, Assembly Processing and Material Handling, and Mr. Phil West. The purpose of this meeting was to discuss possible future visits at General Motors in regard to our manufacturing research.

One topic of discussion concerned the help that General Motors might be able to provide in identifying both short- and long-term problems in the area of manufacturing systems, particularly of scheduling algorithms, line balancing, and real-time rescheduling due to machine failures. Mr. Daley indicated the willingness of G.M. to cooperate to the greatest extent possible with our team. He felt that the problems were attempting to address were truly significant, both in the short and the long range. He reiterated that there is not enough research that is being carried out at this time in this class of complex problems.

Mr. Daley indicated that work planning at General Motors is loosely divided between the tactical level (the day-to-day, on-the-floor management of schedules, tasks, and deadlines, carried out under Mr. Beecher's direction) and the long-term planning problems carried out under the direction of Mr. West. Daley also said that General Motors has just as much interest in the batch manufacturing area as in the high-volume transfer line area. In his mind, so far as General Motors is concerned, it was hard to draw a line between high-volume manufacturing and batch manufacturing. He felt that any progress in this general area can be extremely important, since between 1977 and 1985, General Motors may have to spend, at the minimum, 10 to 50 billion dollars in the whole area of restructuring their manufacturing systems.

Mr. West indicated that members of his staff are responsible for drawing up schedules and line-balancing procedures for several factories. They tend to adopt a somewhat hierarchical approach to this class of problems. He mentioned, but without details, work that deals with scheduling tasks on 180 machines which are quite similar in nature. Unfortunately, no documentation of the existing work was available for outside distribution although West said that members of his staff would be happy to talk with us about this class of problem. With respect to planning and scheduling, they try to work in the time frame of an 8 - 10 week schedule, but they find that, due to the breakdown of machines and materials shortages, all the schedules have to be recomputed often. Their methodology for handling this class of scheduling problems will be of interest to us, when it is possible to go into details.

5.9 Electronic Associates, Inc., West Long Branch, N.J.

A visit was made to Electronic Associates on April 15, 1977. Our host was Mr. Fred Martinson, Vice President, Manufacturing; M.I.T. people making the trip were: J. E. Ward, N. H. Cook, S. B. Gershwin and I. C. Schick.

Mr. Martinson described EAI as a company with \$25M annual sales and about 750 people, 250 of them in manufacturing. The market for analog computers, the primary product of a few years ago, has tailed off and the company has developed other products: hybrid and digital computers, flight trainers for private aircraft, power-plant simulators (@ \$2-4 million each), currency changers, etc.

The company also does contract work on electronic assembly (about \$2m per year) and specialty engineering/construction work. The plant is highly integrated and has in-house facilities for most of the fabrication operations needed: printed circuit board fabrication, sheet metal fabrication, metal parts making, painting, etc. In the assembly area, it has semi-automatic IC insertion equipment (manual card positioning), and plans to acquire axial-lead component insertion equipment in the future. Circuit testing is done on computer-controlled testing equipment.

Aside from a plant tour, most of the time was spent in discussion of scheduling and material control. Mr. Martinson said that EAI is quite automated in data processing in manufacturing, having started in 1962 with a

parts file which now has 70,000 entries. They hold a material review once a week, and schedules are reviewed monthly. Inventory is controlled in three categories: A (expensive), B (medium cost) and C (all the rest). Cycle counts are taken four times/year, twice/year, and once/year, respectively, to monitor the accuracy of inventory records.

Messrs. Ted Lund and Harry Hayman of the Materials Group met with us following the plant tour and described the various scheduling and production control computer programs in use. They have developed four different systems which operate independently, but which in the future they would like to tie together, namely:

- Production Control
- Inventory Control
- Work in Progress
- Purchase Commitment

Each of the systems produces reports as necessary for the various managers who integrate the results by manual methods such as charts, schedule boards, etc. For materials, there is an 'explosion' of the files once per week in such categories as order signal cards, inventory, daily activity, by project, by week, etc. Three Material Analysts, each responsible for 5,000 items, use these outputs to decide on purchases and follow up on them, replacing a staff of some 15 expeditors formerly needed. The Materials Requirements Planning (MRP) System enables them to coordinate materials for all production activity and decide when to release lots of which size.

5.10 AMP, Inc., Harrisburg, PA.

The first of two visits to AMP was made on June 6-7, 1977, by Messrs S.B. Gershwin, A. J. Laub, and J. E. Ward. Our AMP host was Earl J. Hagan, Manager, Materials Engineering. Six different AMP facilities in a 30-mile radius of Harrisburg were visited in the two days, including: an inter-plant warehouse (one of several), the application tooling development activity, a plastics molding plant (one of several), a connector-assembly plant (one of several), an application machine assembly plant and a metal stamping plant (one of several).

Basically, the divisions of AMP that we visited make enormous numbers of small parts, ranging from a small fraction of an inch up to a few

inches in size. Typical output for a stamping plant is one billion terminals per month. In AMP's Terminal Products Division, one of 15 divisions, there are 2,500 active part numbers and 25,000 in AMP as a whole. The bulk of the terminal devices (95%) are produced in strip form, wherein the parts are not completely punched out of the metal strip from which they are formed. The remainder (5%) are punched out of the strips and packed for sale in discrete form. The strip (carrier) form is packaged on reels and used in further AMP assembly operations - for instance, assembling pins into plastic connector bodies, and is also the major form in which the products are used by others - avoiding the need for parts feeders for discrete parts. AMP designs, builds and leases specialized application machines that use the reel-form product and operate at very high speeds -- for example, cutting wires accurate to length, stripping both ends and crimping terminals on both ends at rates of to 5,700 complete terminated wires per hour.

The emphasis on the carrier-strip form of product in the production and use of AMP terminals makes all such operations of continuous flow type in batch runs, i.e., machines do the same thing for the length of a reel of carrier strip, minimum. Also, the tooling required in stamping and application machines, while modular, is quite complex and changeover usually requires a series of adjustments on trial runs to obtain proper operation. Thus, the opportunities for flexible operations at less than reel lots, perhaps several thousand identical operations, are not evident.

Opportunities for flexible operations do arise, however, in customer applications where a number of different AMP products may be assembled into things a customer is making, in a variety of combinations. Milt Ross, Manager of Application Tooling Development, has for some time been examining flexible networks of application machines, where the flexible handling is of the customers' parts, not the AMP products, and at least one transfer-line applicator in which three product lines flow into one has been delivered to a customer.

Based on our visit to the connector assembly plant, there also seem to be more opportunities for flexible operations in some of the AMP component assembly operations - such as electrical connectors - where the order lot sizes may be fairly small and the total number of product types quite

large. A substantial part of the production in the more complex products seems to be in response to specific orders for which a fast response is usually required.

A second visit was made to AMP on June 22, 1978, in response to a request for possible M.I.T. help with the design of a new flexible automated line for assembly of a high-volume electronic part having over 300 product variations. Our host for discussions and a tour of the existing assembly process was Ralph W. Mitchell, Manager of Resource Planning for the Connector and Electronic Products group. The Project personnel were: S. B. Gershwin, J. E. Ward, K. L. Hitz, and J. Kimemia.

Detailed information was obtained on planned new automatic-feed machines under development by AMP, and on product mix statistics. Several suggestions were made by project personnel for in-process part identification coding techniques to permit computer tracking of all operations on a part-by-part basis.

Following this visit, a proposal for a preliminary study of control and scheduling algorithms suitable for on-line computer control, and of coding and tracking techniques, was prepared and submitted to AMP. Due to various subsequent organizational changes within AMP, a funding decision on this proposal was deferred several times. AMP personnel visited M.I.T. on November 3, 1978 and again March 31, 1980, to discuss their progress in the interim and the proposed scope of work. However, AMP informed M.I.T. on April 8, 1980. that they had decided not to proceed with the proposed study at M.I.T.

5.11 GTE Laboratories, Waltham, MA

In response to an inquiry about our project from Dr. John S. Ambrose, Director of Product Planning, S. B. Gershwin and J. E. Ward met with him, Dr. Richard Dworak, Research Manager for Experimental Development, and Dr. E. Bryan Carne, Director of Electronic Technology Laboratory on July 6, 1977. GTE Laboratories perform corporate research and development functions for GTE, which manufactures a wide variety of consumer and business products too numerous to mention here, in addition to operating 21 telephone companies.

Discussions centered around the concepts of flexibility in manufacturing,

a matter of great current interest within GTE (they used the term "short-run production"). They described a robot that has been in operation for several years in a TV tube plant, manipulating hot tubes emerging from a furnace line, and placing them on other conveyors for carriage to the final packaging. We were also shown models and designs for movable robots being developed, in which the robot manipulator hangs inverted from an overhead structure like a giant X-Y plotter, and can be carried at high speed over considerable distances (working areas tens of feet to a side). Possible visits to production plants were discussed. They suggested the TV tube plant in Ottawa, Ohio, and the GTE Automatic Electric plant in Illinois as particularly appropriate and offered to make arrangements whenever we were ready to visit.

5.12 Scott Paper Company, Philadelphia, PA

On October 20, 1977, S.B. Gershwin, J. E. Ward, I. C. Schick, and A. J. Laub visited Scott Paper's Philadelphia facility and met with Dr. Matthew P. Gordon-Clark and associates to discuss control problems in a three-machine, two-buffer transfer line operating in the plant.

The particular operation concerns a rolled-paper product-finishing line in which raw paper stock in very large "parent" rolls is first wound off onto smaller rolls ("logs") of the desired diameter in one machine. These are then cut to final product length in a second machine, completing the fabrication steps, and the finished rolls flow to a wrapping machine. The wrapped output of several of these three-machine lines operating in parallel flows to a common, manual packing line. Product handling between these operations is automatic and includes buffering. These three operations constitute an asynchronous transfer line, with all the problems of upset when one or more machines fail for any reasons. Upsets can come from electrical or mechanical machine failures, breakage, or jamming of the product in the machines or interconnecting material-handling equipment, and changeover and rethreading of the parent rolls at the input. Given statistics on failures and repair times, the problem is to optimize the separate operation rates for the three machines, the intermediate buffering required and the line manning. This latter can affect repair times if more than one failure exists at the same time; also, there is a connection between operation rates and failure rates. The system also often operates in a partial failure state in which some percentage of the product is rejected and removed

from the line at a machine, affecting downstream flow rates. The determination of the reject threshold beyond which overall production rate would be improved by stopping the line to repair the difficulty is another interesting problem.

This visit was most interesting because of the similarity of this process to our own transfer-line models. The state-space approaches being taken by us and by Scott were discussed and compared. Contacts have continued with the Scott group, and permission was obtained to use the process as an example in I.C. Schick's Master's thesis (Schick and Gershwin, 1978)*.

5.13 AMF Harley-Davidson, York, PA

This visit was made on June 21, 1978, by four project members, to see and discuss the innovative conveyORIZED motorcycle assembly and material delivery system installed in the York plant in 1973, when production moved from Milwaukee. We were hosted by: Ralph G. Swenson, President; George C. Klein, Vice President, Operations; Arthur W. Donofrio, Director of Industrial Engineering; and C. M. Oussoren, Manufacturing Engineering Manager. M.I.T. visitors were J.E. Ward, S. B. Gershwin, K. L. Hitz and J. Kimemia.

The unique feature of the plant is a "warehouse in the sky", which eliminates almost all floor-level parts delivery and workstation or stockroom storage. A two and one-half days' supply of all parts needed for assembly is carried on six high, overhead, continuously moving conveyors totalling 3-1/2 miles in length and with a capacity of 500,000 pounds. These conveyors dip to floor level at appropriate workstations on the assembly line. The latter is itself a 750-foot, continuously moving, overhead conveyor which has 66 workstations at which the conveyor dips to working height.

In addition to the description and observation of the assembly system, discussions with our hosts concerned scheduling strategies for the line, which makes three different motorcycle models to order, with a very large selection of options (there are over 6,500 different parts and up to 1,300 per completed assembly). Although they had intended to be able to schedule assemblies in almost random sequence, they have found it better to pre-group each day's work and provide each workstation crew with a list of the parts that they will need to pick off the parts conveyors as they go by.

A consideration here is that the round-trip circuit time of each parts conveyor is about 1-1/2 hours.

5.14 AVCO Corporation, Lycoming Division, Williamsport, PA

This visit on June 23, 1978, was made by four project personnel to see and discuss a Kearney and Trecker flexible machining system (FMS) being used for production of crankcases for small piston engines for aircraft. Our host was Cliff McCracken, Director of Manufacturing Engineering.

At the time of our visit, the tow cart line had six stations in operation and was making the two crankcase halves for a horizontally opposed 4-cylinder engine. The full computer control was not yet operational and some parts movements were being manually initiated. Work was under way on foundations for an additional seven machines to make up the full 13-machine line (nine N/C machining centers and four multi-spindle head indexers). When the full line is operational, additional parts will be scheduled, including a 6-cylinder engine crankcase.

We learned that this is a turn-key system and that AVCO Lycoming was depending on the vendor, at least in the beginning, for scheduling analysis and computer software. They hope eventually to build up their own expertise in these areas. They also plan to acquire additional FMS lines for different types of parts, such as cylinder heads, which are now produced by job-shop techniques.

5.15 Sundstrand Aviation Division, Rockford, IL

This visit, April 26, 1979, was made by S. B. Gershwin and J. E. Ward at the invitation of Mr. G. W. Guirl in regard to possible assistance in improving the efficiency of an operating FMS originally installed in 1967 (the first in the U.S.). As a result of the visit, a proposal for an M.I.T. study of the line operation and possible improvements was prepared and submitted to Sundstrand on June 8, 1979. Various telephone interactions took place over the succeeding eight months and it appeared that the proposal would be funded. In January 1980, however, M.I.T. learned that Sundstrand had decided to perform the study in-house.

The problem which Sundstrand would like to solve is that idle time on individual machines has been averaging about 50%, primarily a result of the

inspection and qualification process for each new part type entered. M.I.T. had suggested study of an overlapping technique for part qualification, which if successful, might reduce average idle time to 20% or less. The financial benefit of such a productivity improvement would be very great, since the value added per individual machine-hour is \$200 to \$500.

5.16 Kearney and Trecker, Milwaukee, WI

In October, 1979, S. B. Gershwin visited John J. Hughes, Manager of Automation Engineering, to discuss flexible manufacturing systems. Information was obtained on K&T tow-line FMS's now operating and under installation and plans for changes in implementation of control functions. K&T primarily uses simulation techniques to study line operation and control strategies, as they have reported in various papers.

5.17 Pratt and Whitney Aircraft, E. Hartford, CT (also Middletown, CT)

This visit was made on February 1, 1980, by seven project personnel. The main purpose was to see and discuss a prototype automated lost-wax casting mold system implemented as a 10-station transfer line, with a robot at each station performing the operations of slurry dipping and sand coating. We were particularly interested in learning more about the material handling in this system and the control strategies. Our hosts for the visit were Frank J. Fennessy, Manager, Manufacturing Research & Development; Donald P. Willard, Manufacturing R&D, and Geroge J. Rogers, Manufacturing R&D.

Mr. Fennessy described the automated casting line as a pilot facility to develop the technique as a production tool. It has three main parts:

- a) The preparation of a wax model having on its outside surface the desired outside shapes of the two blade halves and incorporating the desired inside shapes on the surfaces of a ceramic core ("strong-back") molded into the wax. These are largely manual processes used in assembling the strongback into a plastic carrier, and molding the wax in standard lost-wax molding machines.
- b) The ceramic mold line, which is a 10-station automatic line with robots performing all operations, builds up a ceramic-slurry/sand coating in a staged series of dipping, sanding, and drying operations. The "green" coating developed is about 3/16-inch thick. After air-curing and removal of the wax in a microwave oven, the

ceramic shells are fired in a furnace to be ready for the casting operation. Handling in the curing, wax-melt and firing operations is manual.

- c) The casting unit is an impressive installation three stories high and about 100 by 50 feet in size. All operations and handling internally are automatic, once the shells are loaded.

Our main interest was in the robot mold line. Each robot has a "hand" in the form of a chuck which grips each plastic wax core carrier by a projecting rod on the axis of symmetry. The chuck can continuously rotate the carrier as it is dipped in the slurry or held under the sand shower. Robots pick the carriers off hooks on the conveyor and return them to empty hooks when finished with operations. A central computer controls each robot and tells it which carrier to pick up, what to do with it for how long, and where to deliver it. Thus, the computer is in complete charge of material movement of the mold line and can control the work rates at each stage to keep things flowing smoothly. We questioned what would happen if one station went down -- i.e., if a robot failed. The answer was that, in almost all cases, its work would be automatically assigned to other stations having the same slurry; that is, if station 4 went down, and stations 5 and 6 had the same slurry, parts would have an extra dip (with an intermediate dry cycle) applied by either station 5 or station 6, until station 4 was repaired. Rates of other stations would be automatically adjusted to compensate as necessary for the increased workloads on stations 5 and 6. Time between successive dip/dry cycles must be fairly closely controlled, however. Thus, buffering (in the transfer-line context that we have been studying) is not used to decouple stations.

The mold line and casting unit each have dual CDC System 17 process controllers. For each pair of computers, one computer is active and the other is on hot standby. A total of 3,800 parameters are measured or controlled. A larger CDC Cyber 170 "number cruncher" collects, manages, and analyzes process data. Pieces are tracked throughout on a serial-number basis, together with the process parameters that they encountered at each

stage on their trip through the system, so that final quality can be correlated with process parameters. The impression was that this was a very large overhead in computing horsepower for the production rate involved. (This is, however, a development project; it is possible that the size of the computers can be reduced when the processes are perfected and production systems are built.)

On a plant tour, we also had an opportunity to see a number of other new processes being developed, including electron-beam drilling and a hot isostatic press (HIP) facility, which consists of a number of pre-heat chambers, a press chamber (gas pressure), and a cool-down chamber -- all interconnected by a transporter. Relative parts times in the different chambers are different and there are some scheduling issues still under investigation.

Although we did not see or discuss transfer-line or flexible automation systems of the type we have been studying, the visit was most worthwhile for the insight gained into high-technology metal fabrication processes. The two ACF and HIP processes both produce stronger, lighter parts than have hitherto been possible and thus reduce engine weight and improve performance. The level of computer control being applied to the robot mold line and the casting unit was also impressive. These produce very high value-added products from very expensive materials and product quality is an overriding consideration, both for cost and service-reliability reasons. Pratt & Whitney has decided that computer control is the only way to meet these objectives.

5.18 Visits to M.I.T. and Other Interactions

Since the initiation of the project in 1976, personnel from industry have met with project members at M.I.T. for substantial discussions on 19 occasions. The companies involved were:

The Timpkin Co.	Control Data Corp.
United Shoe Machinery Co.	Scott Paper Co.
Eaton Corp.	Nippon Electric Co.
The Boeing Co.	Telemecanique (France)
Siemens Aktiengesellschaft (West Germany)	AMP, Inc.
Terradyne, Inc.	Warner and Swasey
Federal-Mogul Corp.	Combustion Engineering
Lord Electric Co.	Fiat (Italy)
Wright-Patterson AFB (re ICAM)	Brown-Boveri (W. Germany)
Hewlett-Packard Co.	Weyerhaeuser Corp.

Two visitors from industry have spent considerable time in residence with the project:

Jan.-June 1978: Giovanni Secco-Suardo, FIAT

Sept.-Dec. 1979: Albert Morelli, FACOM (France)

As a result of interactions with Scott Paper Company, including the plant visit on 1/11/78, S. B. Gershwin has been acting as a consultant to the company on the modelling and analysis of the buffered transfer-line described in Section 5.12 above.

During 1978-79, the Laboratory held subcontracts from two companies that were prime contractors, respectively, on Tasks I and II, and Task III, of the Air Force program "ICAM Decision and Support System (IDSS)":

Higher Order Software, Cambridge, MA

Hughes Aircraft Co., Fullerton, CA

The Laboratory's participation in the IDSS program was a direct result of its manufacturing research program under NSF Grant APR76-12036 and DAR78-17826.

The IDSS is a part of the overall Air Force ICAM project to improve productivity in aerospace manufacturing and is intended to be a cohesive set of computer simulation and modelling programs for analysis of manufacturing systems. Active participation was through the first phases of the respective programs, October 1978 through March, 1979, and included work on an architectural representation for the mathematical modelling process, IDSS planning, and suggestions for models to be included in IDSS.

A substantial number of mail and telephone requests for information and/or reports on the projects' work have been received on a fairly regular basis. There are currently 72 industrial recipients representing 49 different companies on the projects' standard report distribution list. (There are also several recipients in academic institutions.) In addition, the M.I.T. Industrial Liaison Program (M.I.T./I.L.P.) regularly circulates information on project reports to its 250-member organizations, and distributes additional report copies to a selected list. The ILP also acts as a co-sponsor of project workshops for industry under the grant, and handles mailings and registrations.

6. PERSONNEL

The following M.I.T. personnel have devoted a significant amount of effort to the research projects summarized here.

Faculty

Michael Athans
 Nathan H. Cook
 Leonard A. Gould
 Bernard Levy

Research Staff

Oded Berman
 David A. Castanon
 Elizabeth R. Ducot
 Stanley B. Gershwin
 Steven C. Glassman
 Alan J. Laub
 John E. Ward

Students

Mostafa H. Ammar	Irvin C. Schick
Leon Ekchian	Wei-Tek Tsai
Ellen Hahne	John N. Tsitiklis
Yehiam Horev	R. Paul Wiley
Magid Ibrahim	
Paris Kanellakis	
Ejaz A. Khan	
Joseph G. Kimemia	
Rami Mangoubi	
Brenda Pomerance	

Visitors

Konrad Hitz (University of Newcastle, New South Wales, Australia)
 Giovanni M. Secco-Suardo (Centro Richerche FIAT, Torino, Italy)

7. STEERING COMMITTEE

This research has been greatly helped by the presence of a Steering Committee consisting of experts in the field of manufacturing from industry and from other academic institutions. They have observed presentations and have provided advice and direction. The membership of this Committee, which has changed over time, has included:

Moshe M. Barash, Purdue University

Robert H. Eisengrein, Kingsbury Machine Tool Corporation

John J. Hughes, Kearny and Trecker Company

Frank H. McCarty, Raytheon Company

Loren K. Platzman, Georgia Institute of Technology

Don T. Phillips, Texas A&M University

Joseph P. Sweeney, AMP Incorporated

Albert B. Von Rennes, Bendix Research Laboratories

8. PROJECT DOCUMENTS

8.1 Reliability and Finite Buffers

8.1.1 Published Paper

Gershwin, S.B. and O. Berman (1980), "Analysis of Transfer Lines Consisting of Two Unreliable Machines with Random Processing Times and a Finite Storage Buffer," AIEE Transactions, 12, 4.

8.1.2 Conference Proceedings

Ammar, M.H. and S.B. Gershwin (1980a), "Equivalence Relations in Queueing Models of Manufacturing Networks," Proceedings of the Nineteenth IEEE Conference on Decision and Control.

Gershwin, S.B. and M.H. Ammar (1979), "Reliability in Flexible Manufacturing Systems," Proceedings of the Eighteenth IEEE Conference on Decision and Control.

Gershwin, S.B. and I.C. Schick (1979a), "Analytical Methods for Calculating Performance Measures of Production Lines with Buffer Storages," Proceedings of the Seventeenth IEEE Conference on Decision and Control.

8.1.3 MIT ESL/LIDS Reports

Ammar, M.H. (1980), "Modelling and Analysis of Unreliable Manufacturing Assembly Networks with Finite Storages," MIT Laboratory for Information and Decision Systems Report LIDS-TH-1004. (Master's thesis).

Ammar, M.H. and S.B. Gershwin (1980b), "A Partially Formulated Method for Solving Three-Machine Transfer Lines," MIT Laboratory for Information and Decision Systems Report LIDS-TM-1046.

Berman, O. (1979), "Efficiency and Production Rate of a Transfer Line with Two Machines and a Finite Storage Buffer," MIT Laboratory for Information and Decision Systems Report LIDS-R-899.

Gershwin, S.B. and O. Berman (1978), "Analysis of Transfer Lines Consisting of Two Unreliable Machines with Random Processing Times and a Finite Storage Buffer," MIT Laboratory for Information and Decision Systems Report ESL-FR-834-7.

Gershwin, S.B. and I.C. Schick (1979b), "Analysis of Transfer Lines Consisting of Three Unreliable Machines and Two Finite Storage Buffers," MIT Laboratory for Information and Decision Systems Report ESL-FR-839-9.

Gershwin, S.B. and I.C. Schick (1980a), "Modelling and Analysis of Two- and Three-Stage Transfer Lines with Unreliable Machines and Finite Buffers," MIT Laboratory for Information and Decision Systems Report LIDS-R-979.

Gershwin, S.B. and I.C. Schick (1980b), "Continuous Model of an Unreliable Two-Stage Material Flow System with a Finite Interstage Buffer," MIT Laboratory for Information and Decision Systems Report LIDS-R-1039.

Schick, I.C. and S.B. Gershwin (1978), "Modelling and Analysis of Unreliable Transfer Lines with Finite Interstage Buffers," MIT Laboratory for Information and Decision Systems, Report ESL-FR-834-6; (Master's thesis of I.C. Schick).

Ward, J.E. (1980), "TI-59 Calculator Programs for Three Two-Machine One-Buffer Transfer Line Models," MIT Laboratory for Information and Decision Systems Report LIDS-R-1009.

8.2 Routing and Scheduling

8.2.1 Published Papers

Kanellakis, P.-C. and Papadimitriou, C.H. (1980), "Local Search for the Asymmetric Traveling Salesman Algorithm," OR 28,6.

Papadimitriou, C.H. and P.C. Kanellakis (1980), "Flowshop Scheduling with Limited Temporary Storage," Journal of the ACM, 27,3 p. 533-549.

8.2.2 Conference Proceedings

Kimemia, J. and Gershwin, S. B. (1979), "Network Flow Optimization in Flexible Manufacturing Systems," Proceedings of the Seventeenth IEEE Conference on Decision and Control.

Secco-Suardo, G. (1979), "Workload Optimization in an FMS Modelled as a Closed Network of Queues," Annals of the CIRP, Vol. 28, No. 1, pp. 381-383.

8.2.3 MIT ESL/LIDS Reports

Hitz, K. L. (1979), "Scheduling of Flexible Flowshops," MIT Laboratory for Information and Decision Systems Report LIDS-R-879.

Hitz, K. L. (1980), "Scheduling of Flexible Flowshops - II," MIT Laboratory for Information and Decision Systems Report LIDS-R-1049.

Kanellakis, P.-C. (1978), "Algorithms For a Scheduling Application of the Asymmetric Traveling Salesman Problems," MIT Electronic Systems Laboratory Report ESL-R-834-5 (also printed as ESL-TH-823).¹

Kanellakis, P.-C. and C. H. Papadimitriou (1979), "Local Search for the Asymmetric Traveling Salesman Algorithm," MIT Laboratory for Information and Decision Systems Report LIDS-P-927.

Kimemia, J. G. and S. B. Gershwin (1980), "Multicommodity Network Flow Optimization in Flexible Manufacturing Systems," MIT Laboratory for Information and Decision Systems Report ESL-FR-834-2.²

Papadimitriou, C. H. and P.-C. Kanellakis (1978), "Flowshop Scheduling with Limited Temporary Storage," MIT Electronic Systems Laboratory Report ESL-p-808.

Secco-Suardo, G. (1978), "Optimization of a Closed Network of Queues," MIT Electronic Systems Laboratory Report ESL-FR-834-3.

8.3 Syntheses

Hahne, E. H. (1980), "Dynamic Routing in an Unreliable Manufacturing Network with Limited Storage," in preparation: Master's thesis.

-
1. Master's thesis.
 2. Master's thesis of J.G. Kimemia

Tsitsiklis, J.N. (1980), "Optimal Dynamic Routing in Unreliable, Continuous Queueing Networks," in preparation (M.S. thesis).

8.4 Other Documents

8.4.1 Conference Proceedings

Athans, M., L.A. Gould, and J.E. Ward (1976), "Complex Materials Handling and Assembly Systems," Fourth NSF/RANN Grantee's Conference on Production Research and Technology.

Athans, M., J.E. Ward, S.B. Gershwin (1977), "Progress in Flexible Automation and Materials Handling Research," Fifth NSF Grantee's Conference on Production Research and Technology.

Gershwin, S.B., M. Athans, J.E. Ward (1978), "Progress in Flexible Automation and Material's Handling Research 1978," Sixth NSF Grantee's Conference on Production Research and Technology.

Gershwin, S.B., M. Athans, J.E. Ward (1979), "Progress in Mathematical Methods for Manufacturing Systems, 1979," Seventh NSF Grantee's Conference on Production Research and Technology.

8.4.2 MIT ESL/LIDS Reports

Athans, M., N.H. Cook, S.B. Gershwin, I.C. Schick, J.E. Ward (1977), "Complex Materials Handling and Assembly Systems - First Interim Progress Report," MIT Electronic Systems Laboratory Report ESL-IR-740.

Athans, M., N.H. Cook, S.B. Gershwin, Y. Horev, P.C. Kanellakis, J. Kimemia, I.C. Schick, J.E. Ward (1977), "Complex Materials Handling and Assembly Systems - Second Interim Progress Report," MIT Electronic Systems Laboratory Report ESL-IR-771.

Gershwin, S.B., M. Athans, J.E. Ward (1980), "Complex Materials Handling and Assembly Systems, Volume I, Executive Summary," MIT Laboratory for Information and Decision Systems Report ESL-FR-834-1.

8.4.3 Bachelor's Theses

Kahn, E.A. (1977), "Modelling and Optimization of a Complex Manufacturing Process," Bachelor of Science Thesis, MIT Department of Electrical Engineering and Computer Science.

Pomerance, B. (1979), "Investigation of a 3-Machine Transfer Line," Bachelor of Science Thesis, MIT Department of Electrical Engineering and Computer Science.

9. OTHER REFERENCES

Documents prepared with the support of National Science Foundation grants APR76-12036 and DAR78-17826 are listed in Section 8. References in the text to these documents appear with an asterisk (*). Other literature cited in this report is listed here.

- Artamonov, G. T. (1977), "Productivity of a Two-Instrument Discrete Processing Line in the Presence of Failures," Cybernetics, Vol. 12 No. 3, March 1977.
- Anderson, D. R. and C. L. Moodie (1969), "Optimal Buffer Storage Capacity in Production Line Systems," International Journal of Production Research, Vol. 7, No. 3, pp. 233-240, 1969.
- Barten, K. (1962), "A Queueing Simulator for Determining Optimum Inventory Levels in a Sequential Process," Journal of Industrial Engineering, Vol. 13, No. 4, pp. 245-252, July-August 1962.
- Buzacott, J. A. (1967a), "Markov Chain Analysis of Automatic Transfer Line with Buffer Stock," Ph.D. Thesis, Department of Engineering Production, University of Birmingham, 1967.
- Buzacott, J. A. (1967b), "Automatic Transfer Lines with Buffer Stocks," International Journal of Production Research, Vol. 5, No. 3, p. 183-200, 1967.
- Buzacott, J. A. (1972), "The Effect of Station Breakdowns and Random Processing Times on the Capacity Flow Lines with In-Process Storage," American Institute of Industrial Engineers Transactions, Vol. 4, No. 4, pp. 308-312, December 1972.
- Coffman, E. G., Jr. (editor) (1976), Computer and Job-Shop Scheduling Theory, Wiley, New York.
- Cook, S. A. (1971), "The Complexity of Theorem Proving Procedures," Proceedings of the Third ACM Symposium on Theory of Computing, pp. 151-158.

- Cristofides, N. (1976), "Worst Case Analysis of a New Heuristic for the Travelling Salesman Problem," in Algorithms and Complexity (J. Traub, ed.), Academic Press.
- Dattatreya, E. S. (1978), "Tandem Queueing Systems with Blocking," Ph.D. Thesis, Department of Industrial Engineering and Operations Research, University of California, Berkeley.
- Freeman, M. C. (1964), "The Effects of Breakdowns and Interstage Storage on Production Line Capacity," Journal of Industrial Engineering, Vol. 15, No. 4, pp. 194-200, July-August 1964.
- Garey, M. R., D. S. Johnson, and R. E. Tarjan (1976), "The Planar Hamiltonian Circuit Problem is NP-Complete," SIAM Journal on Computing, No. 4, pp. 704-719, 1976.
- Gordon-Clark, M. (1977), Private Communication.
- Graham, R. L. (1978), "The Combinatorial Mathematics of Scheduling," Scientific American, March 1978.
- Graham, R. L., E. L. Lawler, J. K. Lenstra and Rinnoy Kan (1978), "Optimization and Approximation in Deterministic Sequencing and Scheduling: A Survey," to appear in Annals of Discrete Mathematics.
- Hanifin, L. E., S. G. Liberty, and K. Taraman (1975), "Improved Transfer Line Efficiency Utilizing Systems Simulation," Society of Manufacturing Engineers, Technical Paper MR75-169, 1965.
- Hildebrand, D. K. (1968), "On the Capacity of Tandem Server, Finite Queue, Service Ssystems," Operations Research, Vol. 16, pp. 72-82, 1968.
- Hillier, F. S. and R. W. Boling (1966), "The Effect of Some Design Factors on the Efficiency of Production Line with Variable Operation Times," Journal of Industrial Engineers, Vol. 17, No. 12, pp. 651-658.
- Hillier, F. S. and R. W. Boling (1977), "Toward Characterizing the Optimal Allocation of Work in Production Line Systems with Variable Operation Times," Advances in Operations Research, Proceedings of EURO II, Marc Reubens, Editor, North-Holland, Amsterdam.

- Houtzeel, A. (1979), "The Many Faces of Group Technology," American Machinist, January 1979.
- Hutchinson, G. K. (1977), "The Control of Flexible Manufacturing Systems: Required Information and Algorithm Structures," IFAC Symposium on Information - Control Problems in Manufacturing Technology, Tokyo, Japan, October 1977.
- Hutchinson, G. K. and J. J. Hughes (1977), "A Generalized Model of Flexible Manufacturing Systems, Proceedings of Multi-Station, Digitally Controlled Manufacturing Systems Workshop, University of Wisconsin, Milwaukee, January 1977.
- Karp, R. M. (1972), "Reliability Among Combinatorial Problems," Complexity of Computer Computation, (R. E. Miller and T. W. Thatcher, eds.), Plenum Press, pp. 85-109.
- Kay, E. (1972), "Buffer Stocks in Automatic Transfer Lines," International Journal of Production Research, Vol. 10, No. 2, pp. 155-165.
- Koenigsberg, E. (1959), "Production Lines and Internal Storage - A Review," Management Science, Vol. 5, pp. 410-433, 1959.
- Lageweb, B. J., J. K. Lenstra, and A. H. G. Rinnoy Kan, "A General Bounding Scheme for the Permutation Flow Shop Problem," Operations Research, Vol. 26, No. 1, January-February 1978.
- Lenstra, J. K. (1976), "Sequencing by Enumerative Methods," Math. Cent. Amsterdam.
- Lenz, J. E. and J. J. Talavage (1977), "General Computerized Manufacturing Systems Simulator," Proceedings of the Conference on the Optimal Planning of Computerized Manufacturing Systems, Purdue University, November 1977.
- Lewis, H. R., and C. H. Papadimitriou (1978), "The Efficiency of Algorithms," Scientific American, January 1978.
- Lin, S., and B. Kernighan (1973), "An Effective Heuristic Algorithm for the Traveling Salesman Problem," Operations Research, Vol. 21, pp. 498-516.
- Masso, J. and M. L. Smith (1974), "Interstage Storages for Three Storage Lines Subject to Stochastic Failures," American Institute of Industrial Engineers Transactions, Vol. 6, No. 4, pp. 354-358, December 1974.

- Muth, E. J. (1979), "The Reversibility Property of Production Lines," Management Science, Vol. 25, No. 2.
- Okamura, K., and H. Yamashina (1977), "Analysis of the Effect of Buffer Storage Capacity in Transfer Line System," American Institute of Industrial Engineers Transactions, Vol. 9, No. 2, June 1977.
- Olker, R. (1978), "Application of the Minicomputer to Control a Large-Scale Flexible Machining System," in Understanding Manufacturing Systems, Vol. 1, Kerney and Trecker, 1978.
- Rao, N. P. (1975), "On the Mean Production Rate of a Two-Stage Production System of the Tandem Type," International Journal of Production Research, Vol. 13, No. 2, pp. 207-217.
- Rao, N. P. (1977), "Two-Stage Production Systems with Intermediate Storage," American Institute of Industrial Engineers Transactions, Vol. 7, No. 4, pp. 414-421.
- Sevast'yanov, B. A. (1962), "Influence of Storage Bin Capacity on the Average Standstill Time of a Production Line," Theory of Probability and Its Applications, pp. 429-438.
- Sheskin, T. J. (1976), "Allocation of Interstage Storage Along an Automatic Production Line," American Institute of Industrial Engineers Transactions, Vol. 8, No. 1, pp. 146-152, March 1976.
- Stover, A. M. (1956), "Application of Queueing Theory to Operation and Expansion of a Chemical Plant," Naugatuck Chemical Company, Naugatuck, Connecticut.
- Thompson, G. L. (1975), "Algorithmic and Computational Methods for Solving Symmetric and Asymmetric Traveling Salesman Problems," Working Paper, Workshop on Integer Programming, Bonn, Germany.