

BUILDING AS SYSTEMS

SUBMITTED IN PARTIAL FULFILLMENT OF THE
REQUIREMENTS FOR THE DEGREE OF MASTER
IN ARCHITECTURE,

MASSACHUSETTS INSTITUTE OF TECHNOLOGY.

~~AT~~

RUNGSAN TORSUWAN
BACHELOR OF ARCHITECTURE (HONS.)
CHULALONGKORN UNIVERSITY,
BANGKOK, THAILAND, 1963.

PROFESSOR LAWRENCE B. ANDERSON
HEAD DEPARTMENT OF ARCHITECTURE,
MASSACHUSETTS INSTITUTE OF TECHNOLOGY.

June 1965.

BUILDING AS SYSTEMS

M. ARCH. 1965

MASSACHUSETTS INSTITUTE OF TECHNOLOGY

RUNGSAN TORSUWAN

20 Hemenway St., Apt. 28
Boston, Mass.

June 1965

Pietro Belluschi, Dean
School of Architecture and Planning,
Massachusetts Institute of technology

Dear Dean Belluschi:

In partial fulfillment of the requirements
for the degree of Master of Architecture, I
thereby submit this thesis entitled,
"Building as Systems."

Respectfully,

A handwritten signature in black ink, appearing to be 'RT' or similar initials, written over a horizontal line.

Rungsan Torsuwan

ACKNOWLEDGEMENTS:

I wish to thank the following whose assistance and advice contributed substantially to the included thesis project:

Thesis Supervisor

Professor Eduardo F. Catalano

Structures

Professor Wacław Zalewski

Mr. Leon Groisser

TABLE OF CONTENT

TITLE OF THESIS	
LETTER OF SUBMISSION	
ACKNOWLEDGEMENTS	
TABLE OF CONTENT	
ABSTRACT OF THESIS	
THE PROGRAM	
INTRODUCTION	1.
SYSTEM	2.
APPROACH	4.
GROWTH SYSTEM	5.
BUILDING AS A GROWTH SYSTEM	6.
THE SOLUTION	8.
SITE PLAN	12.
THE STRUCTURE SYSTEM	14.
THE FORM WORK	17.
ASSEMBLY	18.
COLUMNS	19.
THE CORE SYSTEM	21.
ELEVATORS	22.
STAIRS	23.
TOILETS AND CLOSETS	24.
THE ELECTRICAL AND TELEPHONE	
SYSTEM	25.
HORIZONTAL CIRCULATION	26.
THE AIR CONDITIONING SYSTEM	27.
INTERIOR PARTITION	33.

EXTERIOR WALL ELEMENTS	34.
EXTERIOR EXPRESSION	34.
CONCLUSION	35.
BIBLIOGRAPHY	36.

ABSTRACT OF THESIS

The aim of this thesis is to study a building for academic research activities in the fields of science and technology as a system in constructuin and function.

Architecture today is undergoing new changes. There are new concepts in buildings to keep in pace with the expansions needed. The growth of our society has made it necessary for the interval flexibility of expansion.

Buildings of the past cannot offer any real basis of study. It has now become necessary to explore into new scientific methods of inquiry and rationality.

The first part of my thesis treats the study of systems in general and the system of growth by studying nature, historical, and the use of systems as a basis to design the building.

The thesis is concluded with the design of the N.A.S.A. project research building.

THE PROGRAM

The purpose of this program is to study a prototype building of about 600,000 square feet gross floor area- as an integrated system of space, structure and services- to be used for the development of scientific and technological ideas for furthering the exploration of space.

It is required two kinds of spaces:

Simple flexible space where scientists and administrative personal work independently or in groups.

Complex flexible space for laboratories and workshops- to develop three dimensional pieces or components for experimental work, as a preliminary stage before industrial plants undertake the final production of those components. The latter space requires spans not smaller than 40 feet and a very flexible system of services; thus providing working conditions that go far beyond the one used that was described above.

The physical relation between both types of spaces varies with the kind of projects developed. It is difficult to predict at a given time the necessary areas and location for each activity. It is possible to determine only the location of the basic plant, such as mechanical rooms, general service rooms, general workshops, and certain permanent activities. However other activities will change from time to time or unforeseen ones may be needed for special projects.

In order to satisfy these conditions, the building should have:

- a floor area with no less than 30,000 sq. ft. (gross).

- Maximum continuity of its divisible space.

- Modular division of this space.

- Modular supply of services.

- Simplification and concentration of the vertical services through the use of efficient cores growth. The development of a cohesive system of expansion of an area as well as the services that vary in height from floor to floor.

- Demountability of some of its structural parts.

The building should be conceived as a total system
of:

life

growth

circulation

services

construction

Its construction to be based on the use of reinforced
concrete, should be conceived as a total prefabrication
system of components and with total standardization
of its form works.

INTRODUCTION

Our society is growing to larger and larger dimensions. Building for today and for the future must be able to grow. Architects must understand all conditions and forces that are shaping them. We must understand systems of nature, systems of life and our future needs. An understanding of the industrial, materials and scientific-technological that are shaping our design. The construction is the main solution. We have to study and understand it.

By understanding the basic design, architects would be able to apply them and evolve them to a synthesis of integrity and purpose.

Architecture then must be based on a new concept of science and technology as a system in construction, function, economic and future expansions needed.

SYSTEMS

A system is an organic order united by some form of inter-action and interdependence of the parts to the whole. A system can have subsystems and subsystems, such as the human body. A system is the collective parts, each with its own function working together to produce a more important complex function and result.

Nature always has the system in itself, the system of growth, the system of life and the system of living. Even the human fertilization also has the system. Beginning by the fertilization of the mother's egg cell by one of the father's sperm cell will start the birth of a human life. After a period of the growth system there becomes a baby.

Man able to use the system concept to organize their effort such as the government, the military, the industrial, the law, the scientific, the business,

the education, the economic system, and the social system even the small family are all working as system.

APPROACH

The purpose of this thesis is to apply the systematic as a basis to design the buildings for the development of scientific and technological ideas for furthering the exploration of space.

The building must be designed as systems _ system of growth and system of structure,

and other sub-systems:

utility service system.

space flexibility system.

circulation system.

electrical system.

communication system.

mechanical system.

artificial illumination system.

The building is for scientific and technological use, and the increasing demands of needs make the growth system become more important.

GROWTH SYSTEM

Nature creates the growth system, from atom to atoms and cell to cells. Every atom or cell in itself has their own function system. The increasing of the growth is happening to the universe all the time. Nature also creates system of growth based on a mathematical system. The cross section of the tree is the good example to show their growth system. The curve of the increasing ring is always similar to the other. The beauty of the shell which lies in its law of growth, has been reduced to a mathematical formulation.

The cross section of a Twig on plate 1. shows the system of mathematical growth. Plate 2. shows the mathematic growth system of the X-ray diffraction pattern of berly. Plate 3. and 4. all show the nature of the mathematical growth system of the Arachnoidsus Ehrenbergii and the raft of tiny unifrom soap bubbles.

Photomicrograph of a Cross Section of a Twig by I. W. Bailey,
Harvard University.

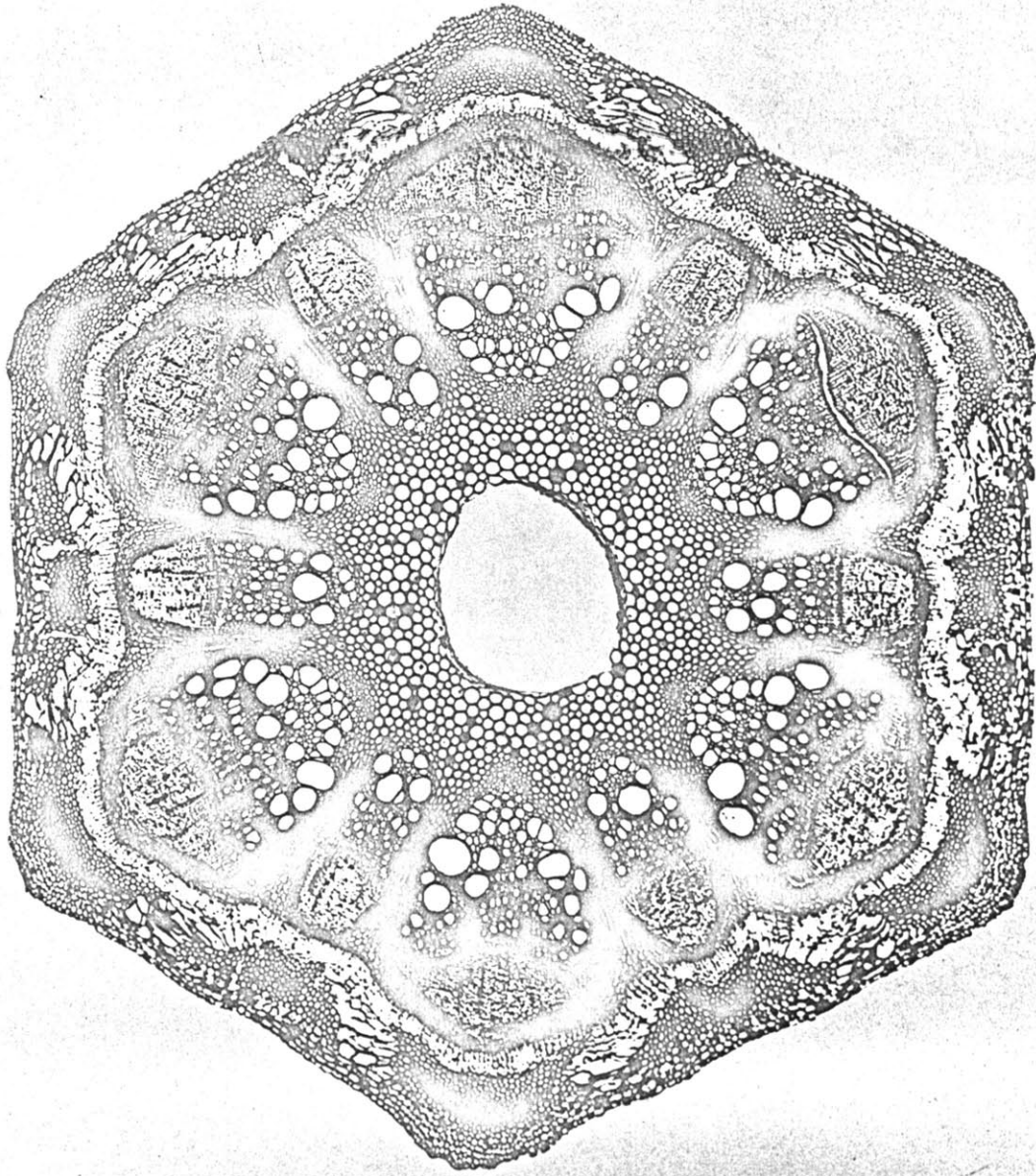

X-ray Diffraction Pattern of Beryl.
(Photo Lane, Eastman Kodak Company)

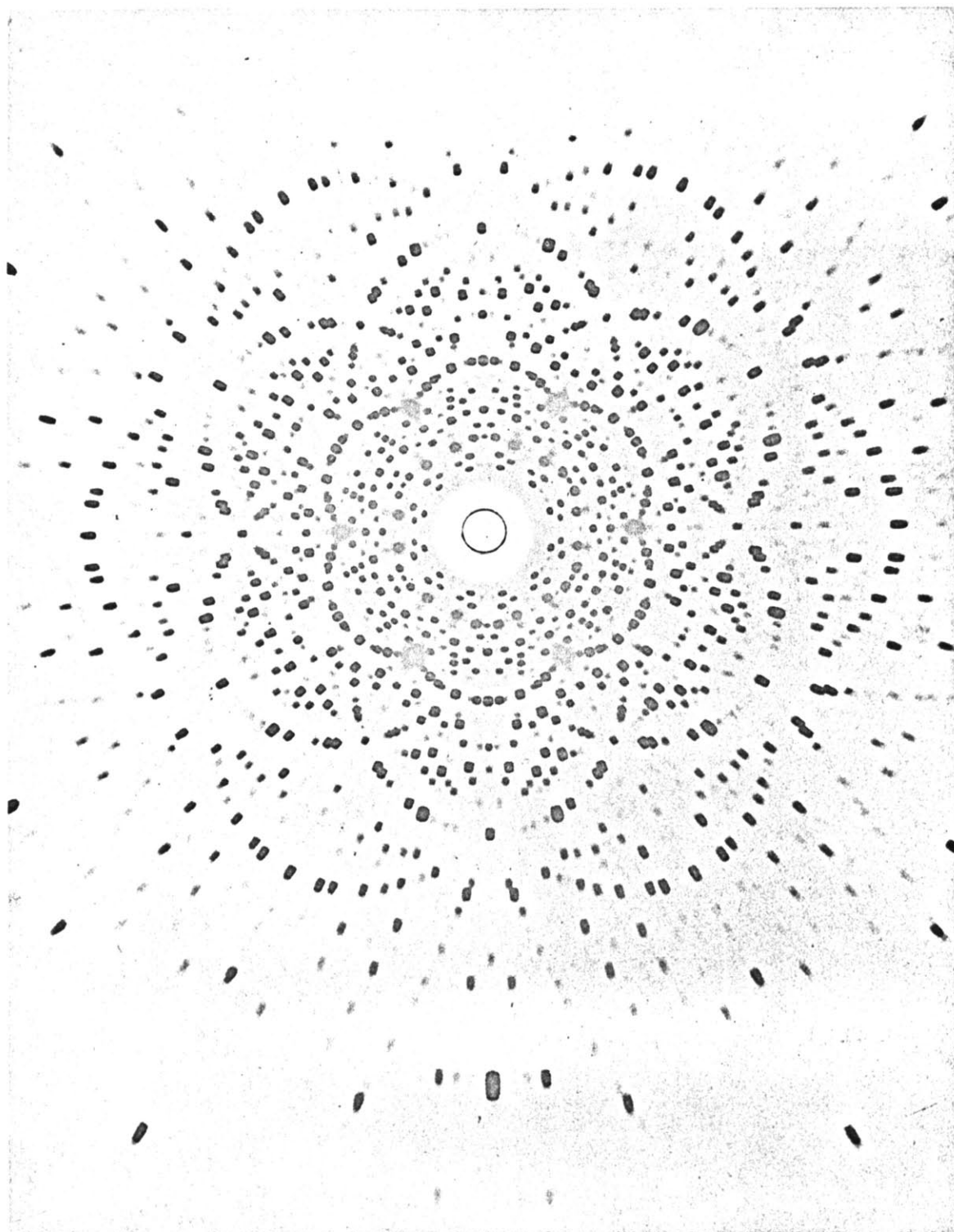

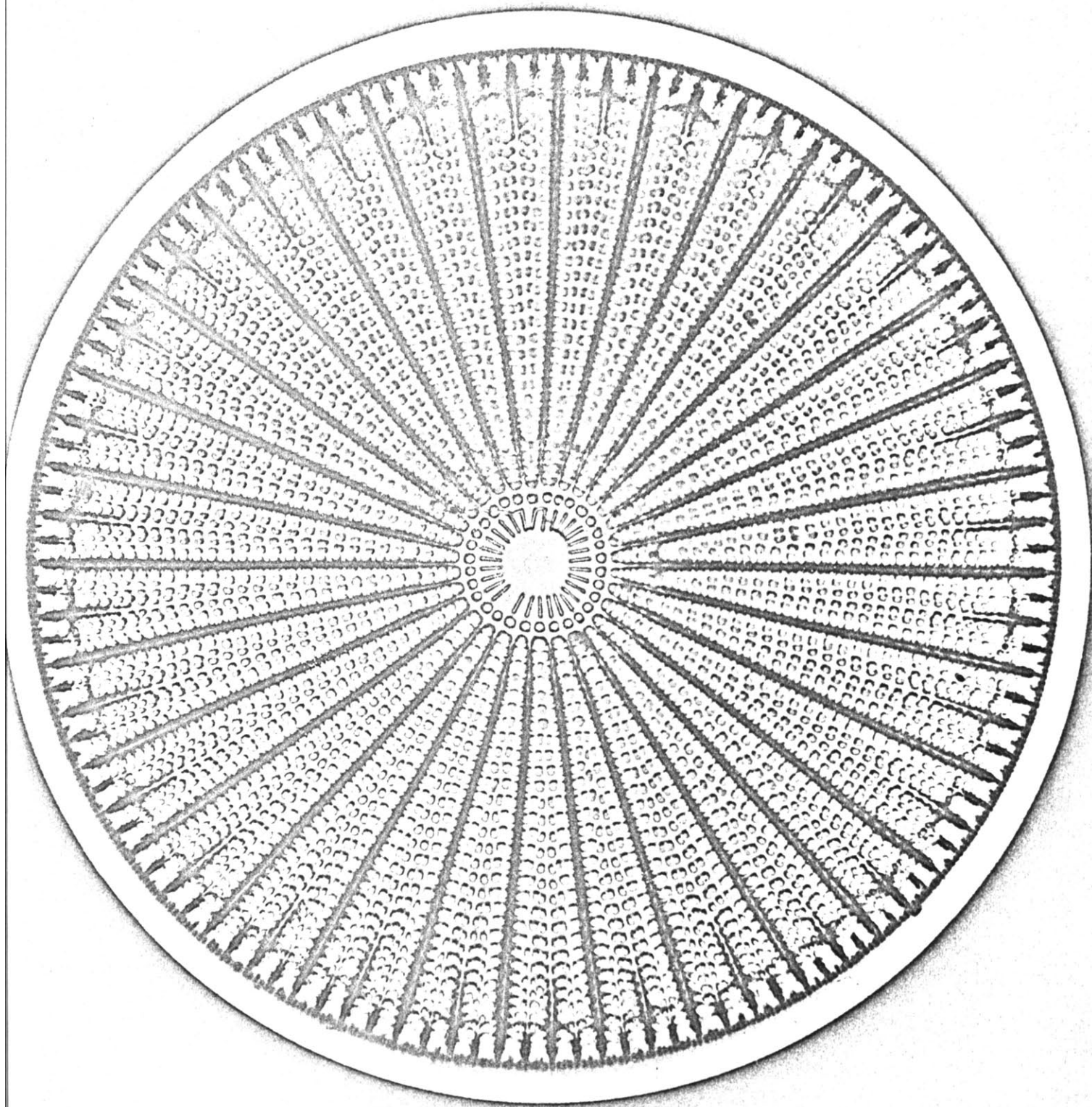

BUILDING AS A GROWTH SYSTEM

Architects create many systems for growth mostly based on the modular system which are the most flexible for the building. The modular in the architecture are not only meant for growth, but also to produce harmony and unity in building. The modular can provide measure which can be used for mass production.

" It is well known that Le Corbusier distinctly believes in the older system of proportion, newly dressed up by him and his team. The elements of his modular are traditional and extremely simple: square, double square, and divisions into extreme and mean ratios. These elements are blended into a system of geometrical and numerical ratios." I.

As a growth system, architects use this modular system to design their building, beginning by the rectangular expansion to the octagonal expansion until the circular expansion. Most of the systems are expansions from the inside to the outside or

I. From the Visual Arts Today by Gyorgy Kepes,
page 216 first to the seventh paragraph.

the outside to the inside or are combined both to expand from the outside.

The expansions not only take place in the horizontal, but also in the vertical direction.

The pictures that are shown on the next pages are showing the modular system and the ability of the growth system.

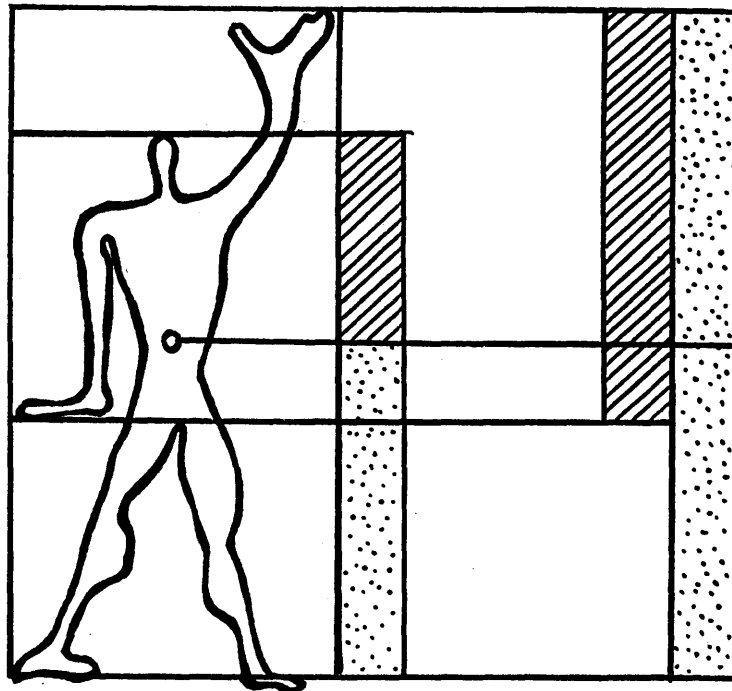

Le Corbusier's Modulor.

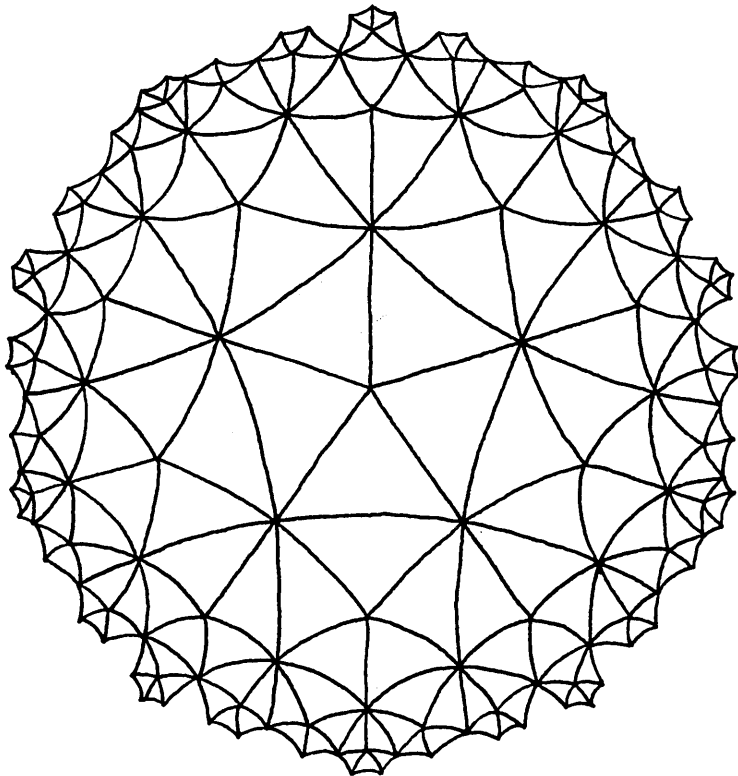
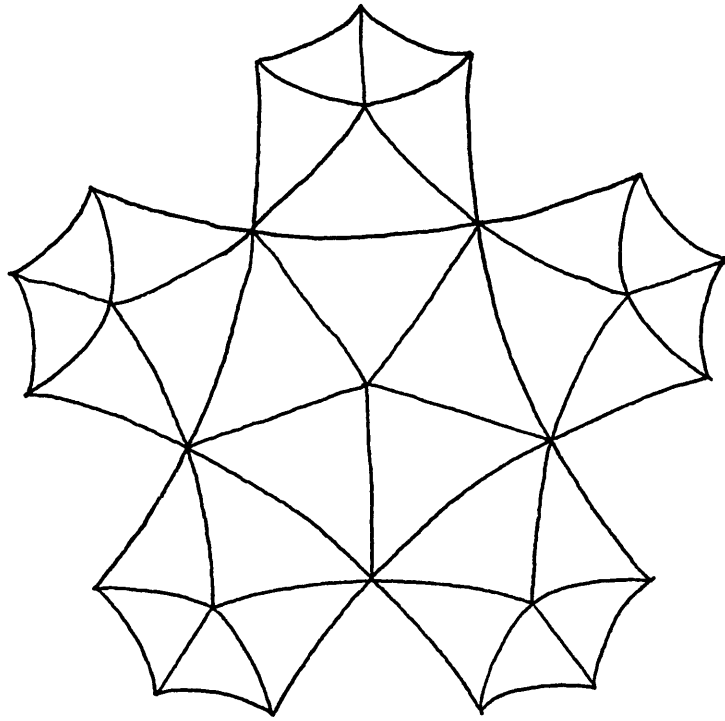

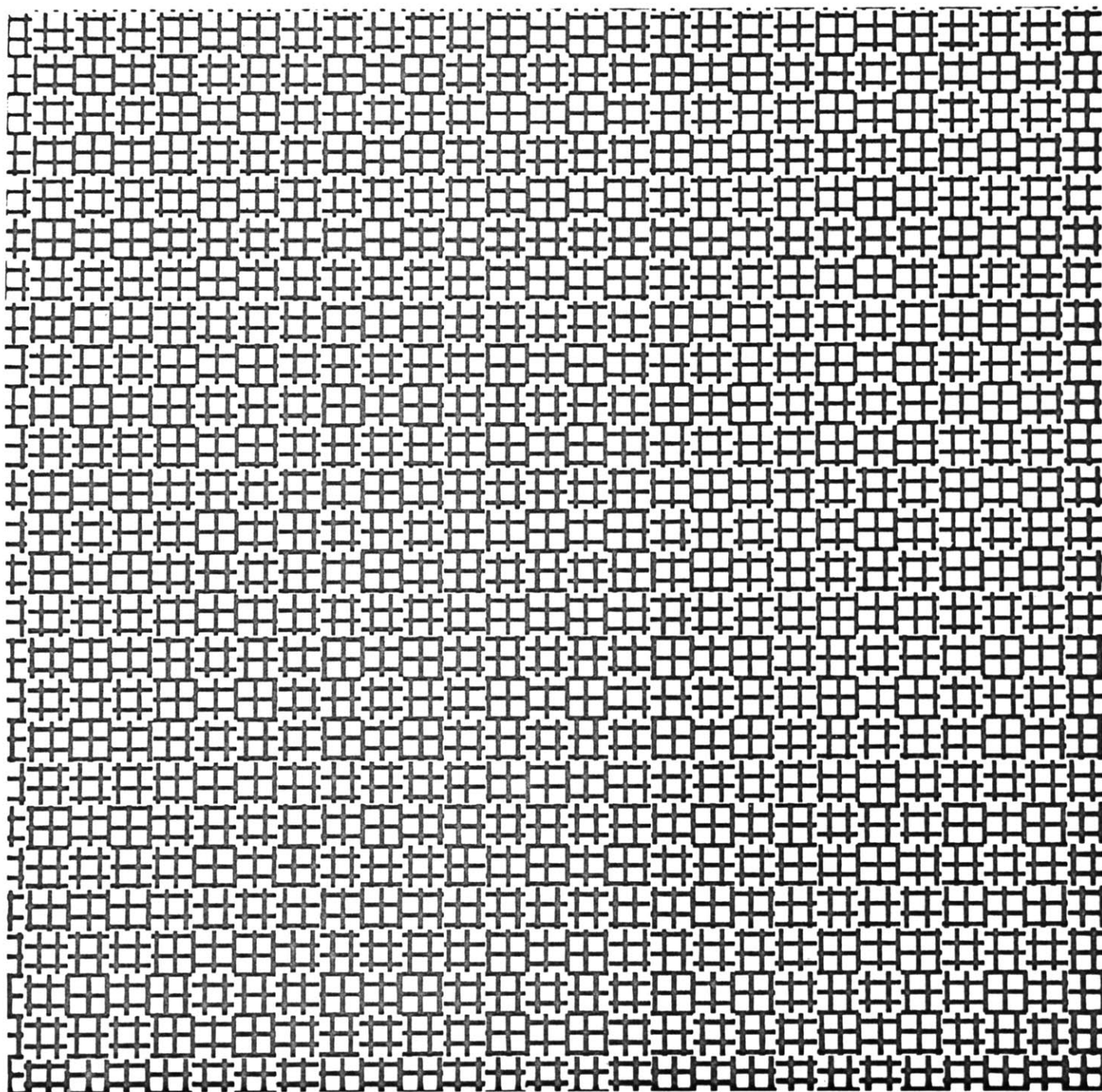
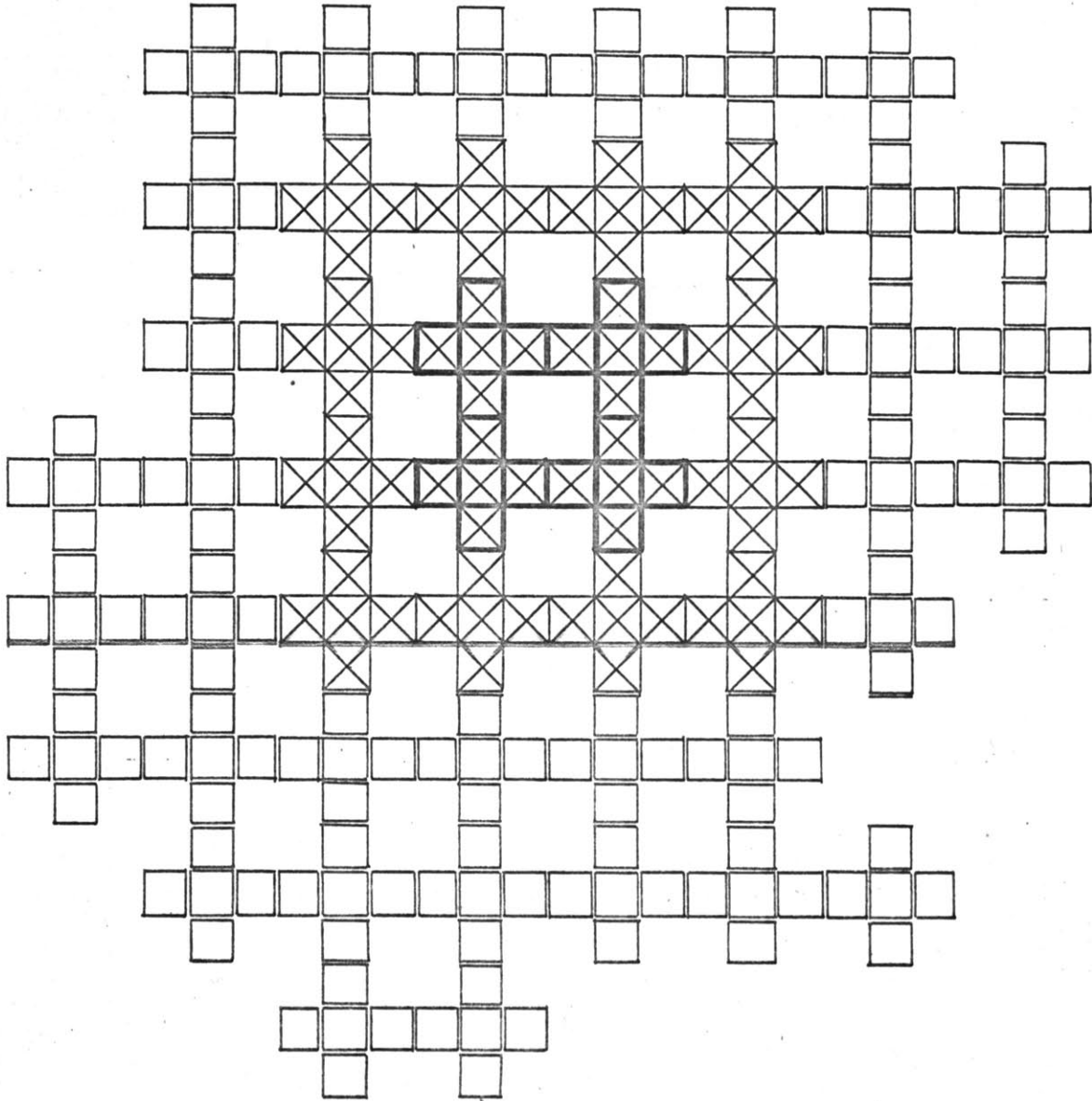
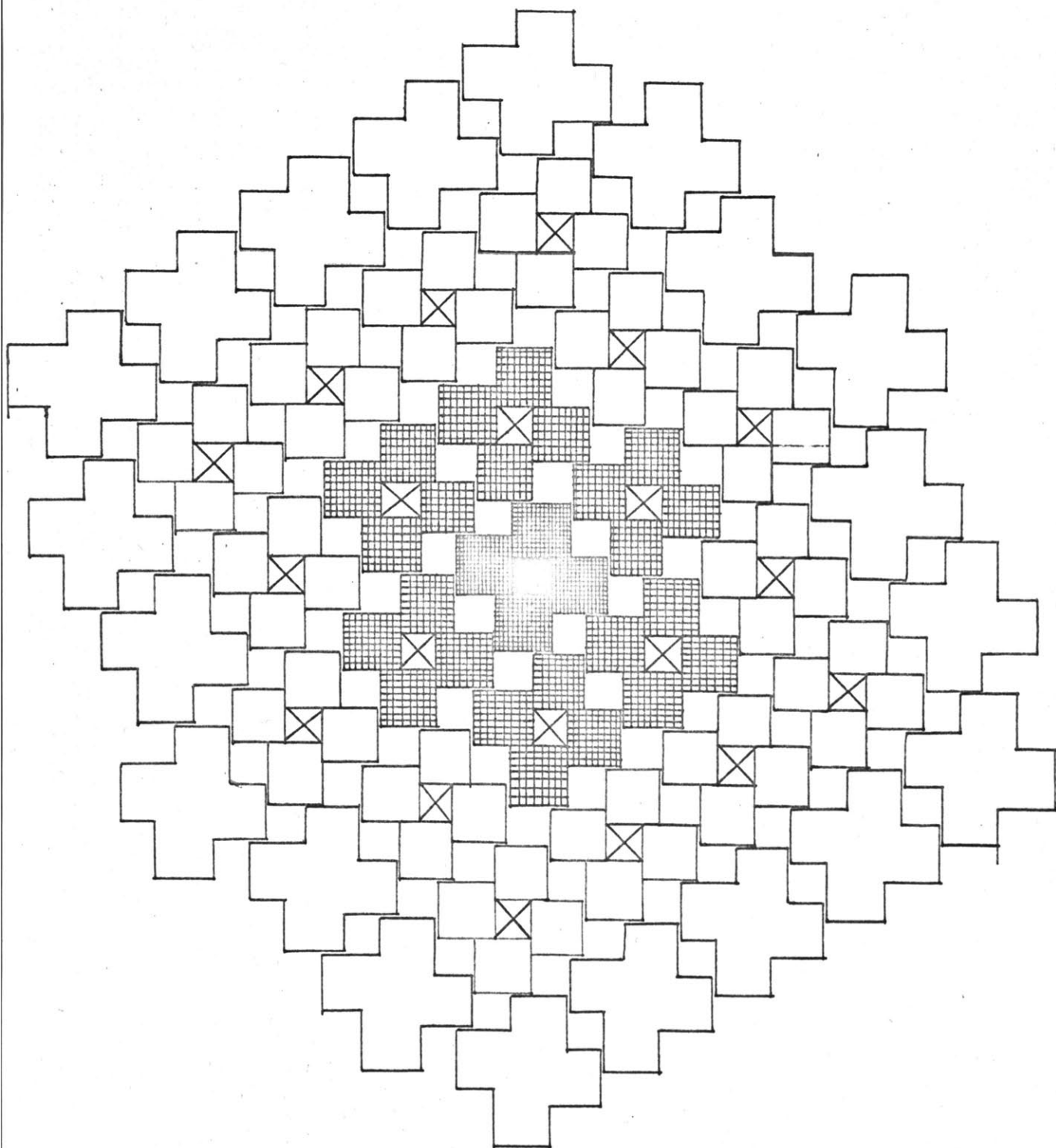

Fig. 10. François Morellet (born 1926). *Dashes 0°-90°*, 1960. Oil on canvas, 80 x 80 cm. Private Collection.



THE RECTANGULAR GROWTH SYSTEM PATTERN



THE CIRCULAR GROWTH SYSTEM PATTERN.

THE SOLUTION

The design of a prototype building is to be used for the development of scientific and technological ideas for furthering the exploration of space.

For such research facility there are two kinds of Major spaces, working spaces and service spaces.

service space are:

vertical and horizontal pedestrian circulation,
vertical and horizontal mechanical services,
electrical and plumbing supply,
business and public telephone supply,
wash rooms and maintenance storage areas,
mail services,
parking facilities and
mechanical rooms.

In the working spaces there are two kinds of spaces required,

simple flexible space and
complex flexible space.

There are still some spaces that we count as the complex space, such as the library, the hall, the administrative office, the lecture hall, the lounges and the cafeteria.

The temporary and permanent system.

The temporary system:

Utility service system.

1. Direct air and fume exhaust.
2. Special temperature control requirements.
3. Utilities of the afluid or gaseous state transfered in pipes or conduit.
4. Additional electric power supply.
5. Closed circuit television system.
6. Business and public telephone supply.
7. Vertical mail service and etc..

The permanent system:

1. Space flexibility system.
2. Structural system.
3. Circulation system.
4. Electrical system.
5. Communication system.
6. ~~Air~~-conditioning system.
7. Artificial illumination system.

In order to satisfy the condition of growth the building should be divided into small units. Every unit must have all the facilities in itself, both service spaces and working spaces, both temporary system and permanent system. The structure becomes more important. Each unit must have a self structure. Four, five or six units combined into one building. This depends on the condition of the site area. The unit can be high or low also depending on the condition of the site. Sometimes the building may be only one unit as a tower if the site is necessary.

The expansion is adding one or two units depending on how much area the expansion needed. In order to have the ability to expand a small area, the unit should be small enough, but not too small for its self-structure and its self-function. To have the ability to expand to most directions this is the best system for the research building. Therefore I will stay on the circular expansion system of this thesis.

The flexible spaces around the center core must be able to change either by decreasing or by increasing

the floor area, by moving or adding partitions. To prevent confusion of the moving or of the rebuilding of the new partitions, it must be regulated by some control. This control can be done by a grid upon which to build partitions. All spaces will grow in a variable quantity from the basic unit of the module of the grid. This module of the grid can be exposed by the floor structure, that is the best way to design.

A module dimension should be:

smallest desirable width for inter-department
circulation 5 feet,
smallest flexible rooms for personnel working
room 10' by 10',
the different room sizes is obtained by
using a 5 feet module.

Therefore we select the 5 feet square as a module.

SITE PLAN

In order to satisfy all requirements, a unit as a pinwheel is the most flexible. The core and the service spaces at the center and the working spaces all around. One unit consists of one center core and four small working space units as the pinwheel system. Every small working unit has their structure separated from the other. The most flexible for growth system, the span should be 45 feet in order to have 15 feet cantileaver. That is the smallest dimension for the cantileaver to be able to provide the working rooms 10' by 10'.

Four units as a building and the center of these four units will provide a center court by the pinwheel system. This center court can be used for the main hall, and the open court of the upper floor also becomes a center horizontal circulation.

The advantage of the pinwheel system is when the time of expansion comes, the joint between

the expansion unit and the main building is 30 feet long. That means that the moving of the exterior surfaces will be only 30 feet long for every time of expansion.

THE STRUCTURAL SYSTEM

The structure is the most permanent system in the building. The space flexibility demands on the exposed floor structure and the five feet square grid are satisfied with a two way grid slab system.

"The remaining concrete in a strong two way grid and approaches the 100% design efficiency, to form a ceiling or floor that will carry the heaviest loads, yet will retain a pleasing and functional pattern. The grid system is adaptable to any floor or ceiling plan and offers a functional modular design with wide open areas and a minimum of columns. Grid ceiling need not be finished or can be painted or sprayed with acoustic materials, if desired."

-1.

The utilities service system demands access openings within the structural depth in both directions. This condition is satisfied by holes in the grids

1. Grid System, Grid Floor Slab Corporation, 1965.

of the slab, which necessitates the increasing of the structure depth. In order to service all the utilities system in the grid floor system, the structural depth increases from 2 feet to 4 feet 6 inches for a span of 45 feet. The modular system of the unit, and the structure system, also for economic purposes, the building is satisfied with the precast concrete system. The structure and every construction element should be able to precast from the industry. Therefore we can use a few form work and a few for labor.

According to Professor Waclaw Zalewski, the structures are designed in the economic and technological system. The unnecessary concrete is cut out and solves the form as the structural way. The precast concrete floor has to be cast into small pieces to solve the problem of shipping and forming. The floor members are shaped by the way of moving out the form work in the industry.

To reduce the number of scaffoldings and the number of concrete joints. The floor units should cast a whole bay of 75 feet in length

and repost-tension one way from the industry
and post-tension in the other way at the site.
One floor unit weighs about 10 tons. The
details of the shearing parts around the columns
will have to be cast in place.

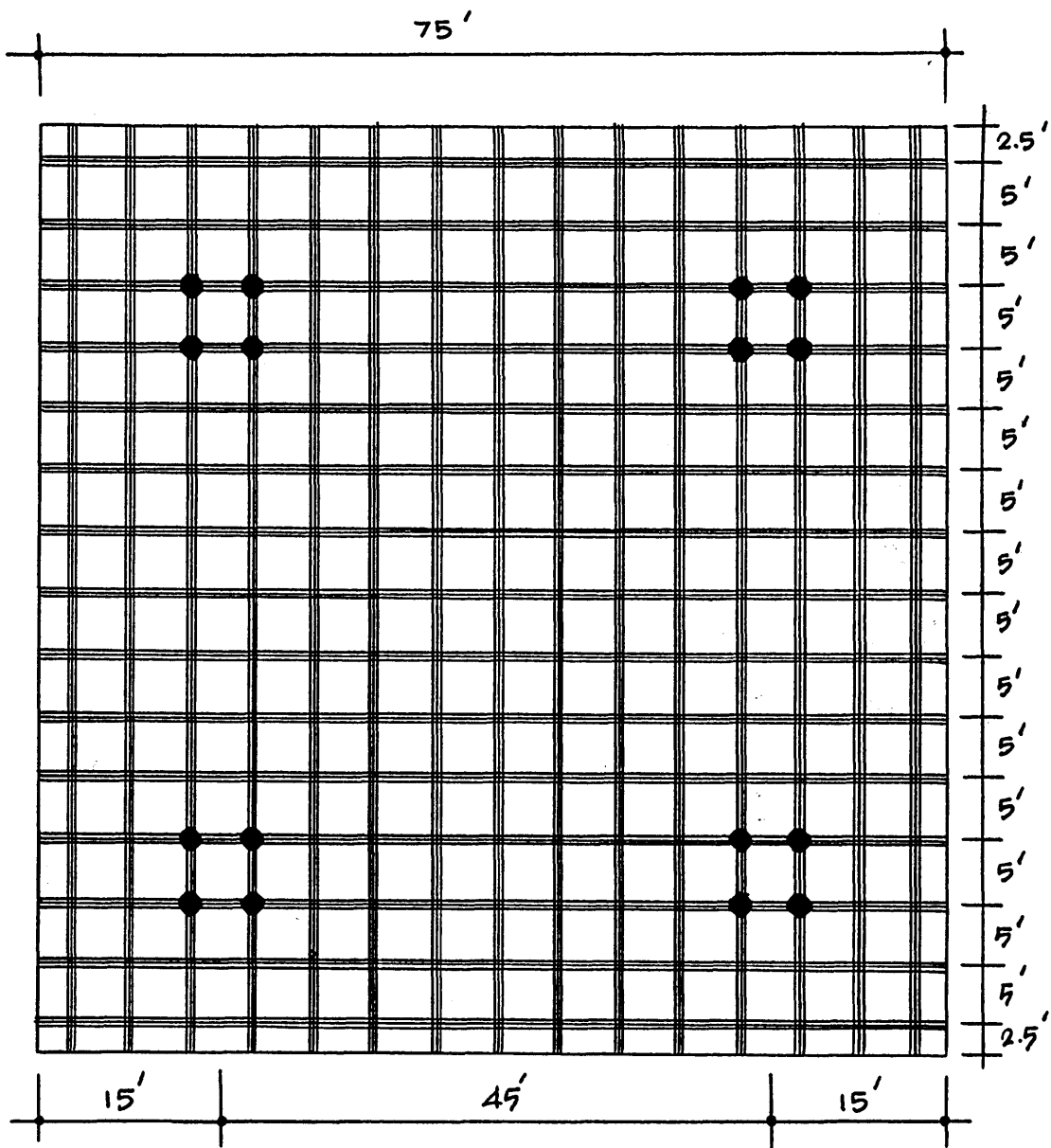

FLOOR SLAB STRUCTURE

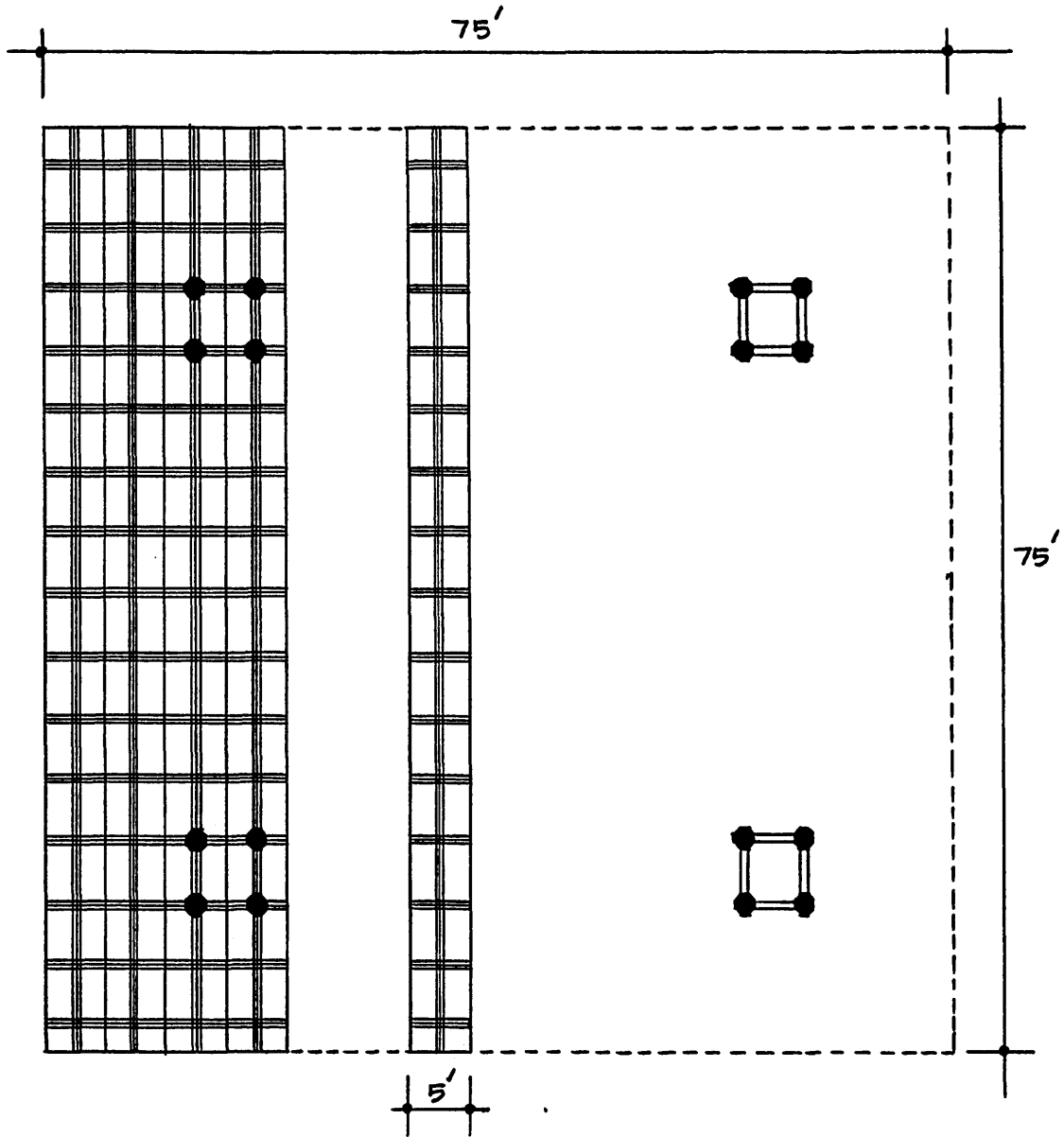

DIMENSION OF FLOOR SLAB UNIT

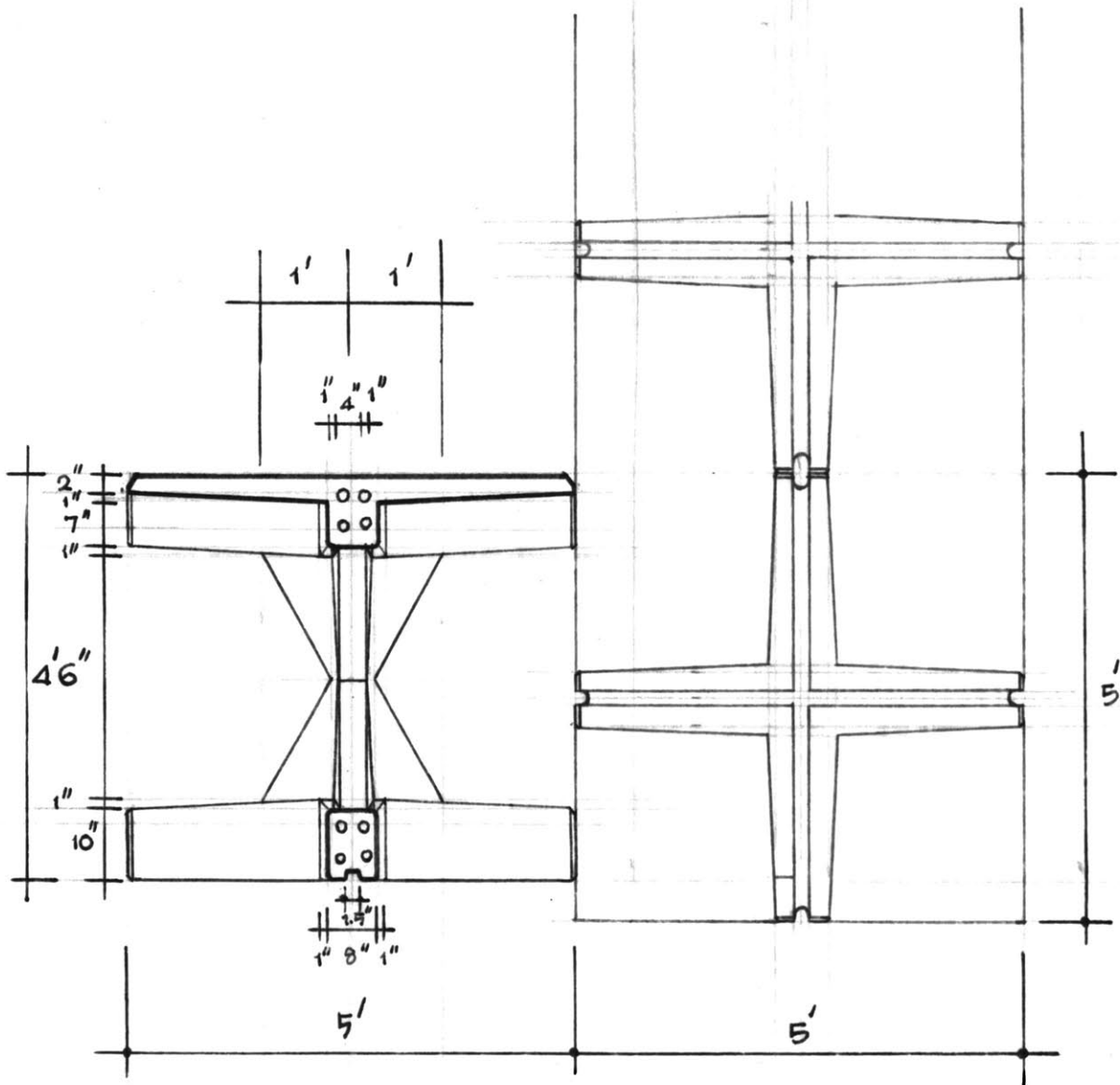

SHAPE AND DIMENSION OF THE FLOOR

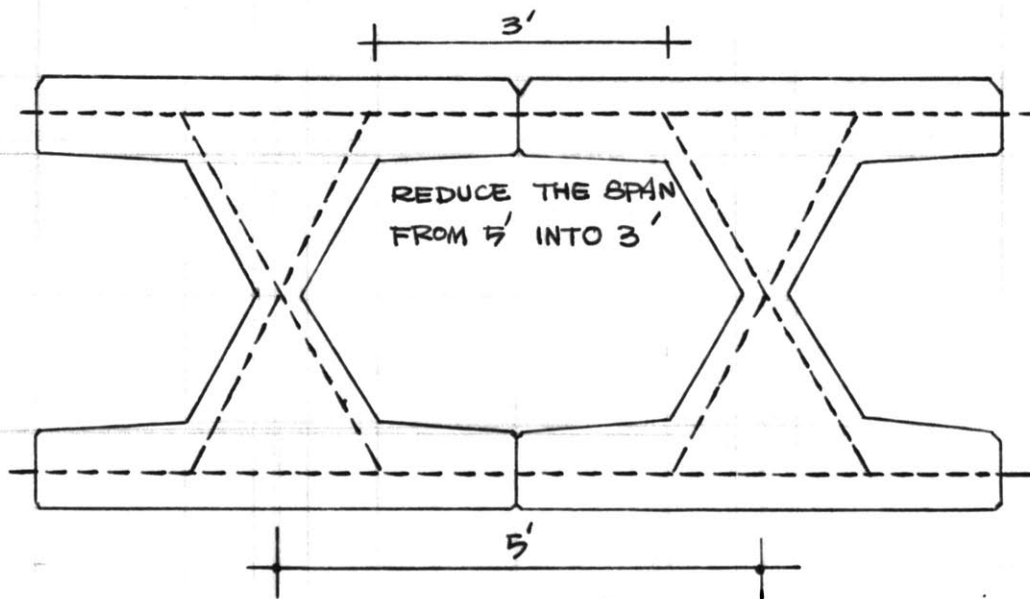

STRUCTURE BEHAVIOR DIAGRAM

POST-TENSION AT THE SITE

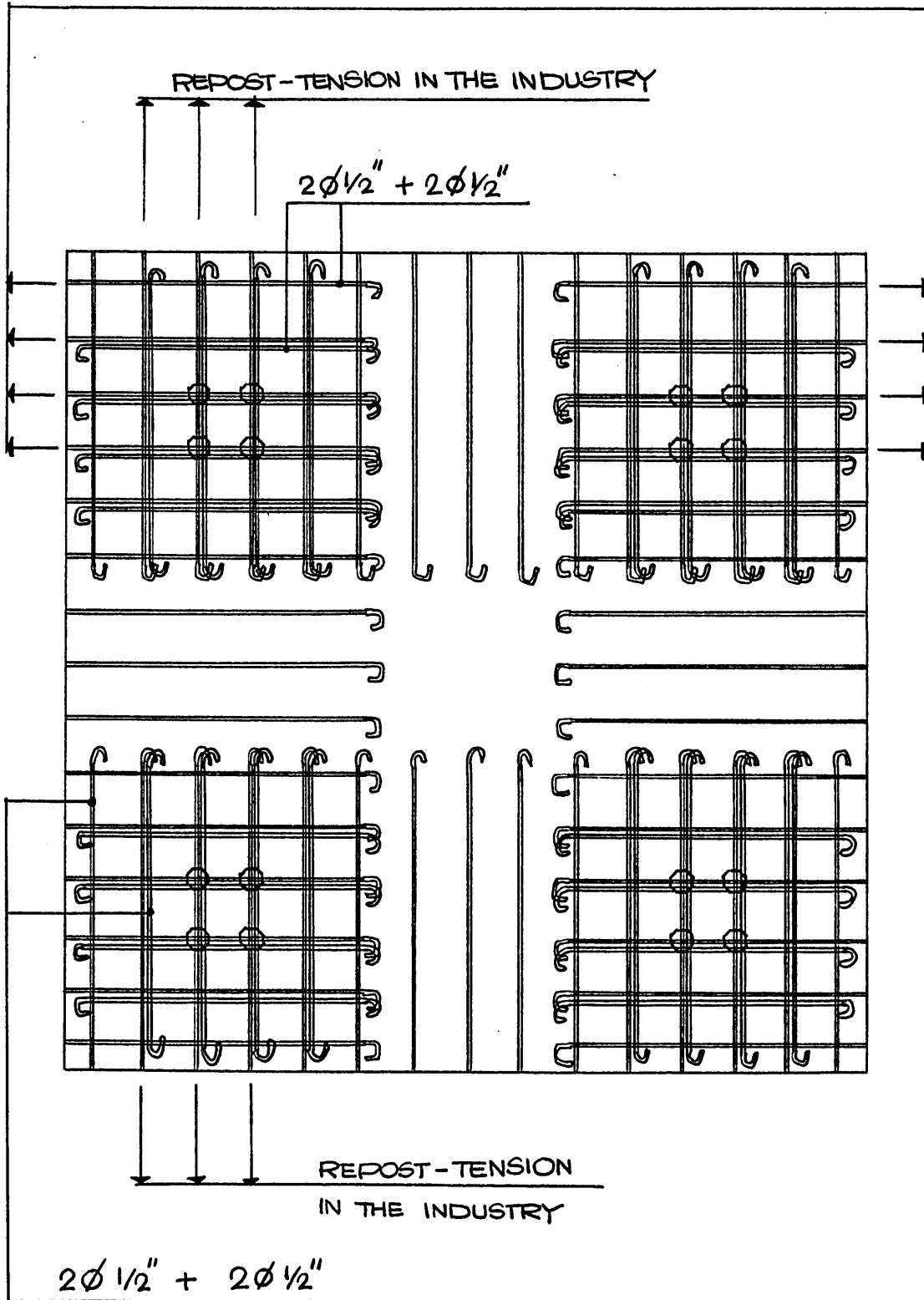

UPPER PART REINFORCEMENT

POST-TENSION AT THE SITE

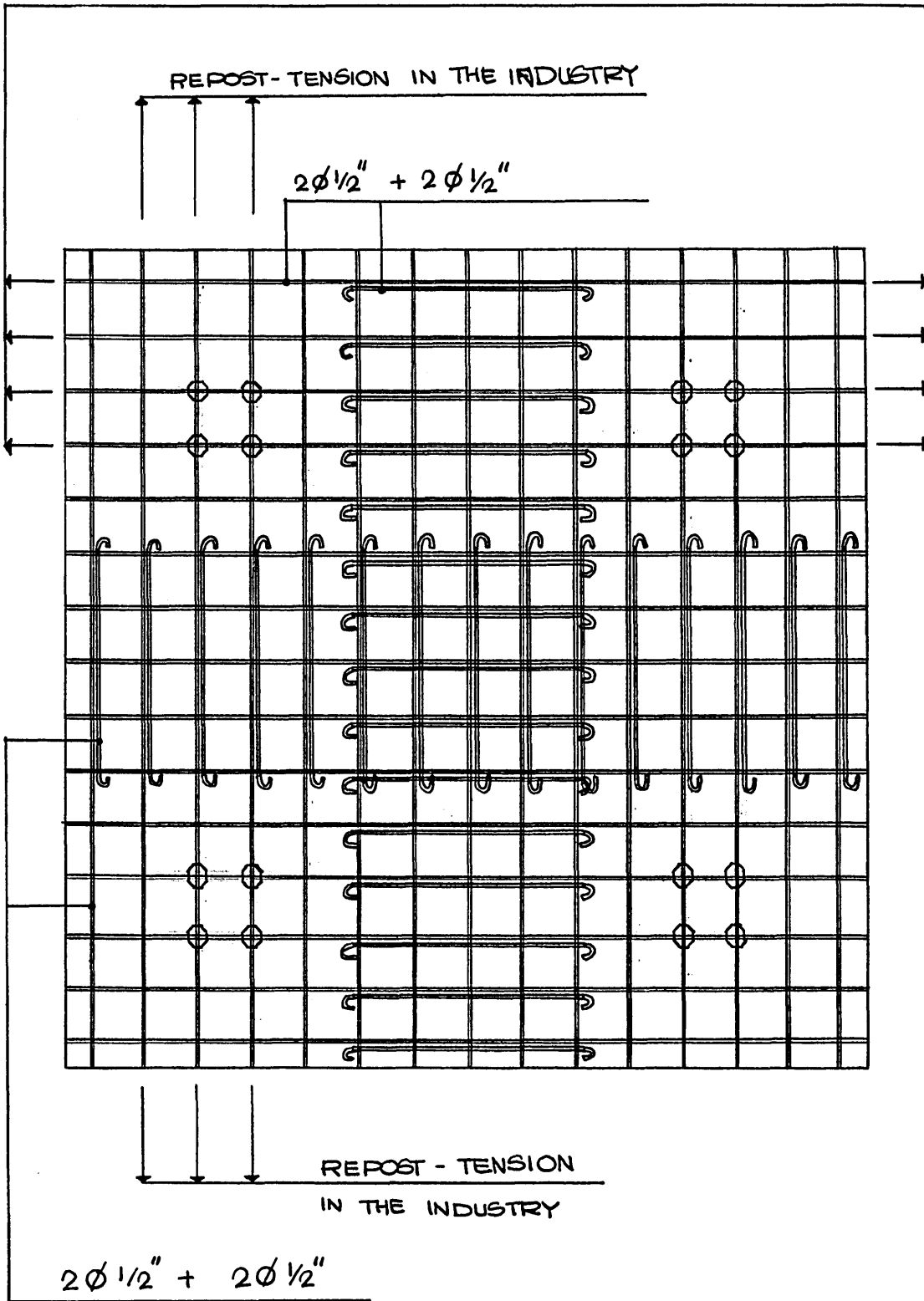

BOTTOM PART REINFORCEMENT

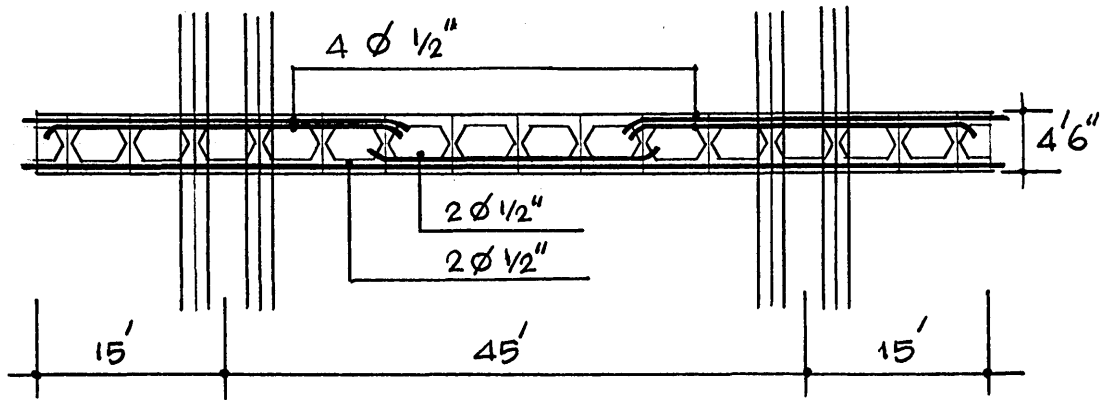

THE REINFORCEMENT AT THE COLUMN PART

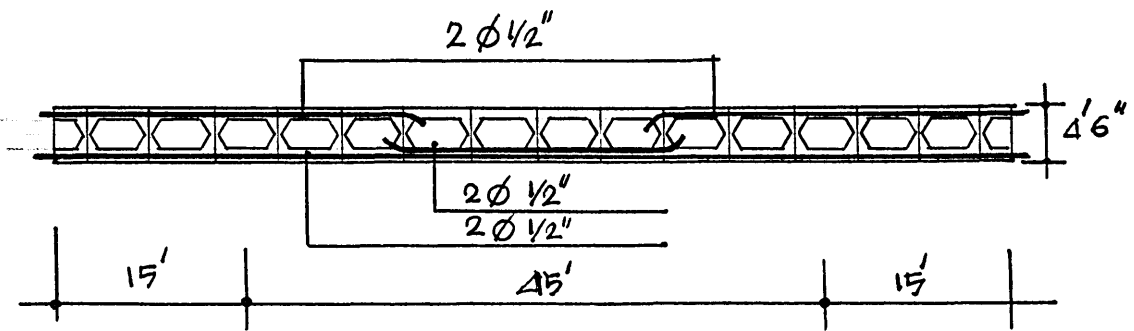

THE REINFORCEMENT AT THE MIDDLE SPAN

THE FORM WORK

By solving the form work, the 75 feet floor unit is designed only 5 feet wide as shown in the drawing. The form-works are moving out from both sides of the floor unit in the horizontal direction. To prevent its cracking by moving, the form-works are designed into every 5 feet module instead of 75 feet long. The material can use steel that is more economical and that last a long time.

For cast in situ structure, the form-work has to be more complicated because of the hold system in the floor structure. Instead of using only two forms as the precast system, the forms have to be one big 5' by 5' form and 4 small forms for the holds in one module, and moving out from the ceiling by the men. The material that are to be used for the forms must be light weight in order for them to be carried by the men. The scaffoldings are needed for all structure area. These are all expensive conditions for the cast in the situ structure.

The structural form of 5' module floor structure is the permanent dimension in every structure element- it is all the same and it is changed by the post-tension reinforcement, and cast in place in the holds for the shearing modules and joints of the columns and the floor.

ASSEMBLY

For assembly we need only two lines of scaffoldings at the columns and then fix the columns in place at the same time. The 75 feet long of the 5 foot module floor slab, that post-tension on one direction already from the industry, is just layed down from one side to the other side by the crain, and by using the hydrolic jacks adjust the joints around the middle of the span for post-tension in another direction. All the drawing in the next page will show the system clearly.

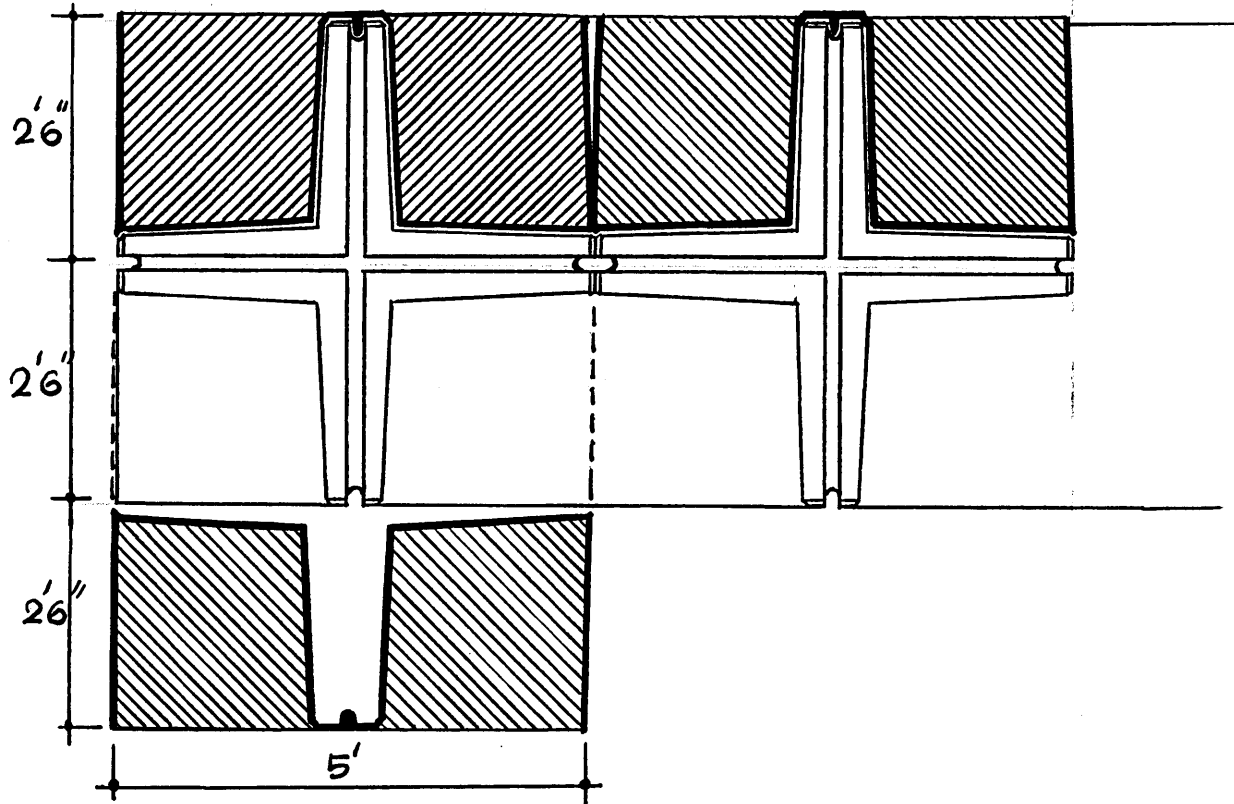
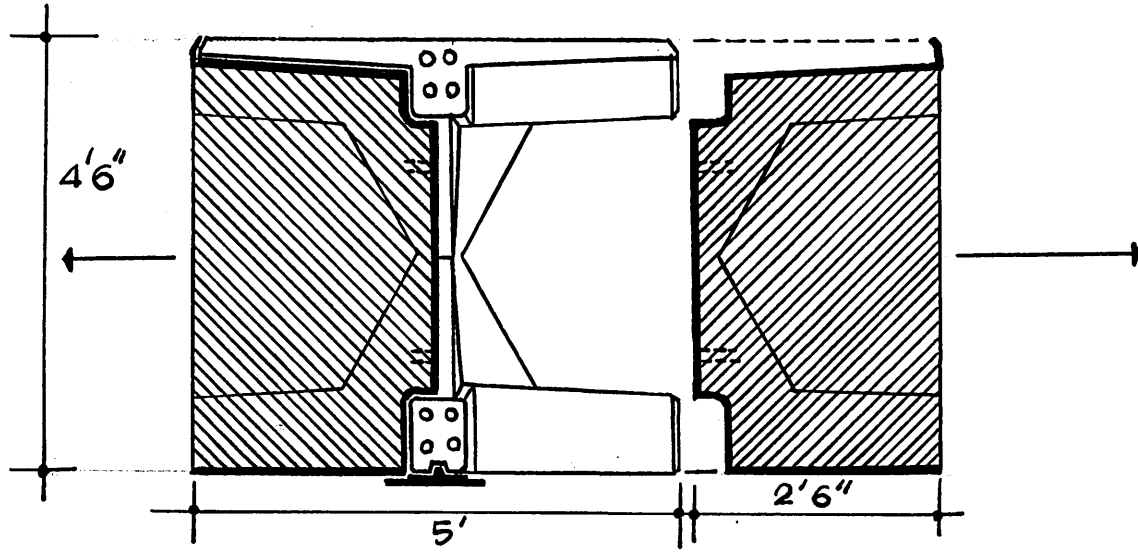

FORM WORK

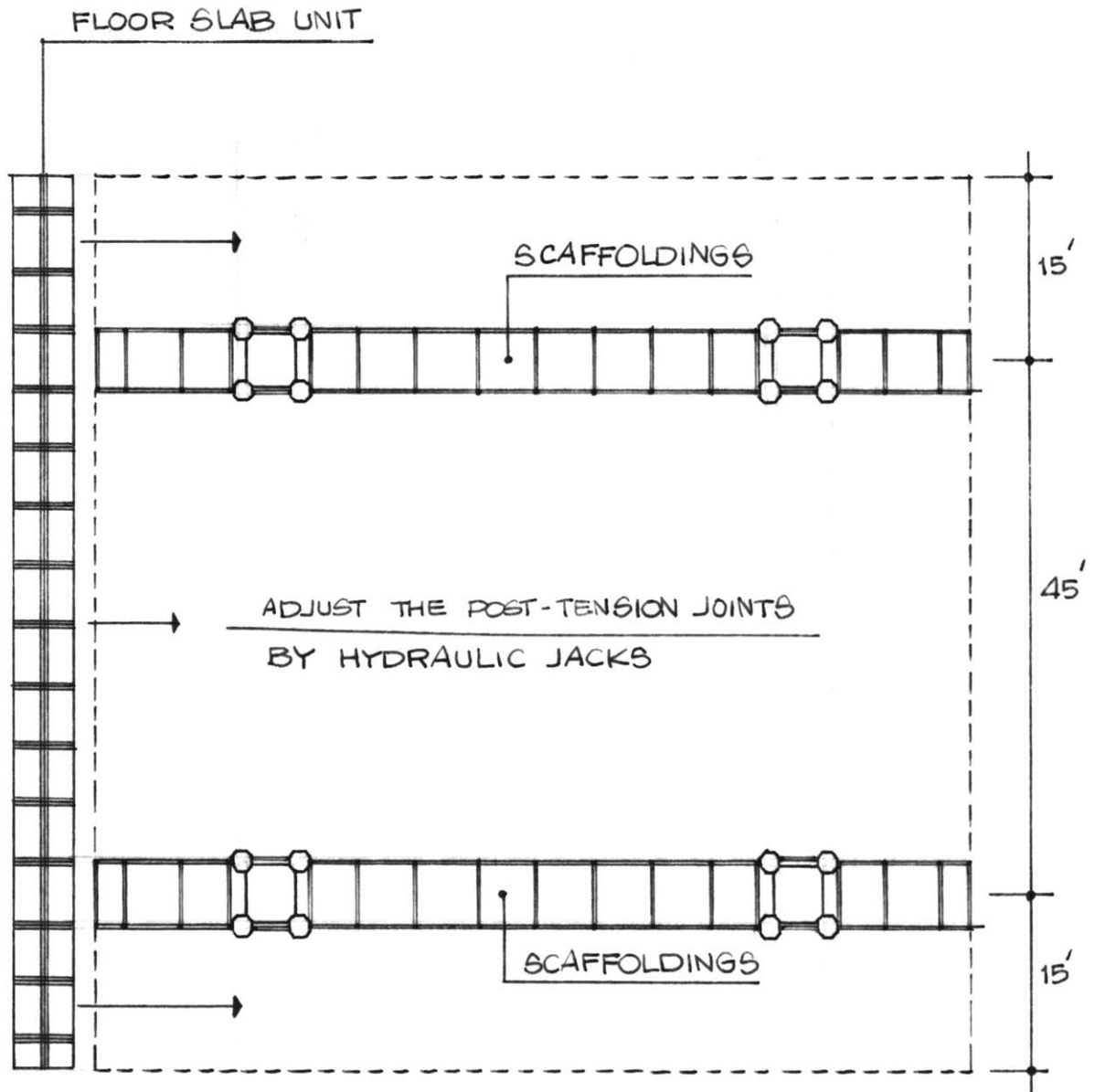

ASSEMBLY SYSTEM

COLUMNS

The precast concrete columns are used for the vertical utilities supply.

such as:

The air conditioning duct both supplies and returns,

The drainage pipe dimension 6"

The hot water pipe dimension 4"

The cold water pipe dimension 2"

The ventilation pipe dimension 2"

gas line

compress air line

vacuum line and

steam line

Therefore it is necessary to have the columns five feet by five feet as one module of the grid floor system. One column becomes four small columns and creates space inside. By calculating the concrete area of a small column for the first floor we need 5 sq. ft. and in order to have the permanent dimension I will design the column's dimension to be only 3 sq. ft. and I will decrease the reinforcement of every floor above.

The shape of the column in the drawing is the result of the grid floor slab system and the way to continue the column with the slab and another column of the upper floor.

The structure of the core is separated in itself by using the walls around the core as the structural system.

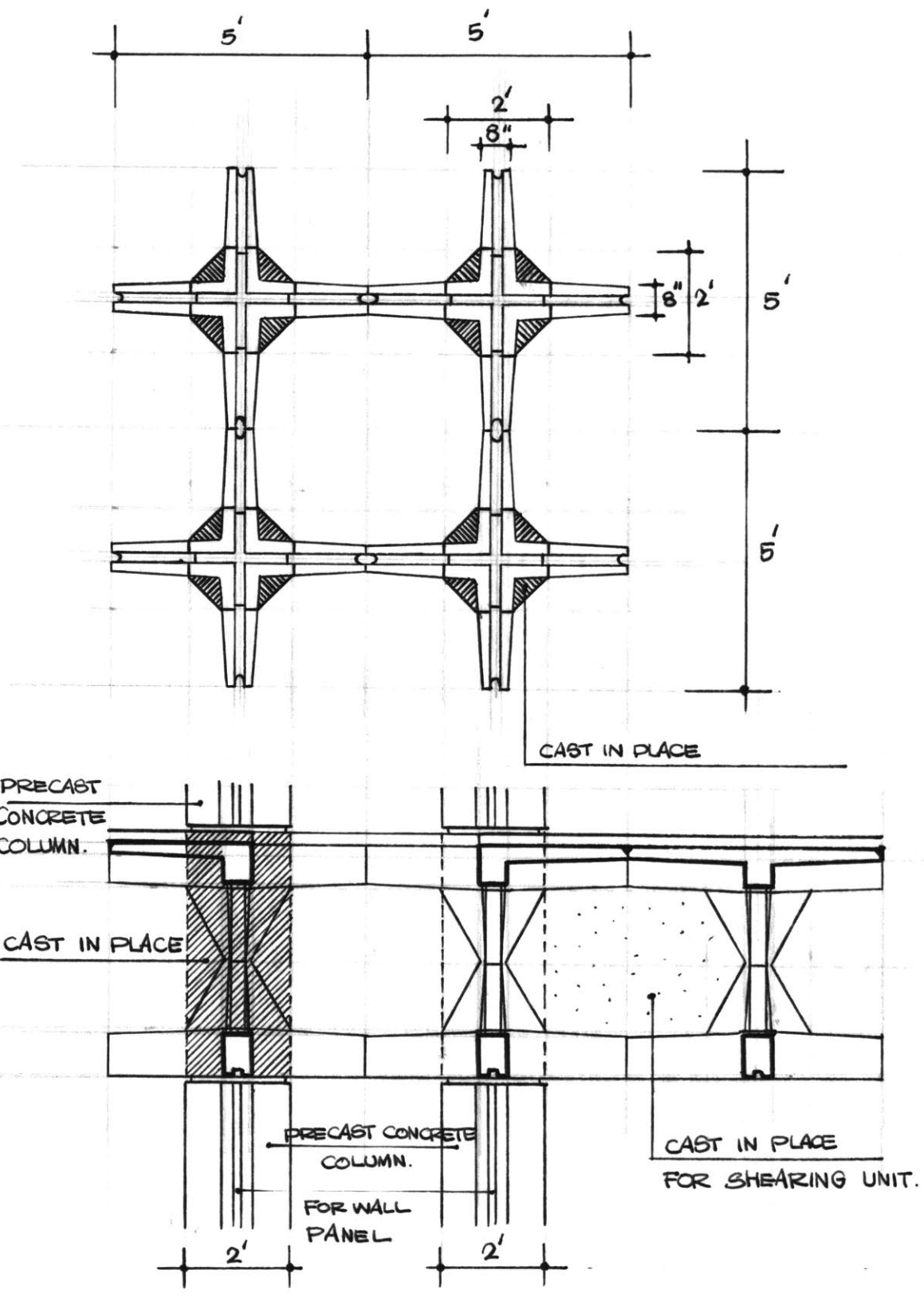

COLUMN

THE CORE SYSTEM

One of the most permanent part of the building and the center of life of the building is the core. The core not only provides the vertical circulation and the utilities service, but it also creates the horizontal circulation and the meeting center of the building of the hall and of the open court.

In an academic research building the core can be divided into two groups, the unicore and the multicores.

In order to have the requirements of the growth system and to prevent any over design in the cores, the cores of the unit system must be the unicores. The cores can serve only the unit themselves and this will provide the horizontal circulation or the minor hallway again.

ELEVATORS

The building is nine stories high and the total area of the flexible space served by the elevators is 607,5000 sq. ft.. The building is devided into cores by the influence of the growth system, and the requirements of the elevators are ten stories high. In the academic research building there are 12 elevators. Therefore they are zoned with 3 elevators serving one unit of the building. The cabin dimension of the elevator provides 6' by 7'. At any time in the expansion, the elevators in the the new core can have 3 elevators, or they can be cut down to one or two elevators. This of course depends on how high the new expansion is.

Only one service elevator is provided at the back of the building in order to serve the service road.from the back side of the main building. The cabin dimensionsof the service elevator can provide 7' by 12'. The other three cores that havn't any service elevator can be combined for storage spaces.

STAIRS

By the building code, the space around the building cannot be more than 150 feet from the fire stair, and by research a 10 story high building needs at least 4 fire stairs. The main point in the design of the fire stairs is that every space around the building will be able to be served by another fire staircase in case of fire at the fire stairway.

The main significant stairway that we have is in the main hall, when the open space of the upper floor is big enough. Anyhow this main staircase is still only suitable for the low building of four or five stories. It is not usefull for a high building at all.

TOILETS AND CLOSETS

The number of toilets are based on the assumed population in the building. We assume 500 people per floor with one toilet per 30 persons, 50 per cent for men and 50 per cent for women. The total need of the toilet should be not less than-

	Men	Women
urinals	6	-
W.C.	9	9
lavs.	7	7

All of these toilets have to be divided into four cores. Each core must have two toilet rooms, one for men and one for women.

The building code in the tropical countries, state that every toilet room should be facing on the outside of the building for ventilation, but this does not seem at all necessary for the temperate countries that are unable to use the natural ventilation system except in the summer time.

Janitor's closet is necessary for each core and the closet should not be less than 60 sq. ft..

One or two drinking fountains disguised as pieces of furniture can be placed at each core.

THE ELECTRICAL AND TELEPHONE SYSTEM

One electrical and telephone closet is needed for each core, and serve the capacity of one unit. The lighting is designed to fit in the five by five square feet of grid floor system as the checkerboard in every 10 feet. The electrical and the telephone wires all running in the grid floor structure with 110 and 220 AC electrical lines that are supplied to each alternating module. Every module is provided with a square lighting fixture that may contain two or four fluorescent light tubes.

Electrical and telephone outlets are on the floor at every ten feet. The public telephones are provided for each core disguised as peices of furniture near the elevators, with a mail shute which comes through from the top to the basement below.

HORIZONTAL CIRCULATION

The location of the permanent cores provide the major horizontal circulation around the cores. These corridors are very usefull and are to be used as the center of circulation for each unit. It is the center meeting between the working space and the service activities. By looking at the plan, the columns around the cores automaticaly create the major corridors which are 12' by 6" wide.

The main open court of the upper floor also creates the minor circulation from core to core and this corridor becomes the center of the building. On the first floor this minor circulation becomes the main hall and the major point which is reached by the entrances of the building.

The other flexible corridors are provided from the major corridor to all of the working spaces. These corridors are flexible to be changed when the flexible working spaces are changed. The width of these corridors are always flexible depending on the function that is needed.

THE AIR CONDITIONING SYSTEM

The air conditioning system is one of the most important and permanent system in the building. The function is to ventilate and to maintain a desired temperature level in the building.

The advantage of the structural system is the using of the columns for running the pipes and the air duct. The air duct sizes are unable to have any air duct large enough to supply the ten story high building.

According to the list that we have-

L.V. 1000 C.F.M. - $2^2 = 1$.

H.V. 3000 to 4000 C.F.M. - $3^3 = 9$.

$4^4 = 16$.

(usually for an outside part of the building

1st system L.V. for the inside of the building

H.V. for the outside of the building

2nd system H.V. for all of the building

3rd system L.V. for all of the building and

it needs a radiator for heat

around the outside part of

the building for the winter time.

Outside		Inside	
90	-	75	summer
-20	-	70	winter

Duct dimensions

Velocity of air : Supply air

low velocity : 1000 C.F.M.

high velocity : maximum : 4000 C.F.M.

advisable: 3000 C.F.M.

Return air

always : 1000 C.F.M.

For Interior Zones : low velocity

1 C.F.M. per sq. ft. of floor area.

duct at low velocity

: 1 sq. ft. per 1000 sq.ft. floor area

For Exterior Zones : high velocity

due to additional cooling or heating needs

4 to 5 C.F.M. per sq. ft. of floor area.

duct at high velocity

: 1 to 1.20 sq.ft. per 1000

sq.ft. of floor area.

Interior zone should not cover a peripheric band window not less than 10 to 15 ft.

Do not forget to leave a space for spare ducts insulation 1" around the supply duct and a few inches to place and to support the ducts from the structure.

The high velocity system even needs a smaller size duct but it is more expensive than the low velocity system. The best air conditioning system is the low velocity for the inside and the high velocity for the outside of the building. But when we are looking at the building that is providing the growth system; it seems to difficult to change the high velocity when the expansion takes place. Therefore I will use the low velocity for the whole building. This expansion is not only problem free, but it is also more economical.

by calculation the space inside the column has only 18.7 sq. ft. area. Then the space for the air duct will not be more than 15.7 sq.ft.. We then need 1" around the duct for insulation and to support the duct from the structure. Therefore the duct size would not be bigger than 14 sq. ft..

Four columns will serve

one structure unit per floor $75' \times 75' = 5625$ sq.ft.

One column will serve only $= 1406$ sq.ft.

duct dimension 1 sq.ft. will serve $= 1000$ sq.ft.

Then 1406 sq.ft. will need duct dimension 1.4 sq.ft

One column will need supply duct

and the return duct $= 1.4$ sq.ft.

The total area of the duct

per column per floor $= 28$ sq.ft.

The space inside the column has only 14 sq. ft..

The duct is only big enough to supply and return
5 floors.

Therefore if we need a column for the air conditioning and the piping system, it is necessary to divide the mechanical room into two levels, one is in the basement feeding to the five floor above.

The advantage of using the columns for the air-conditioning and piping system is to run the horizontal air ducts smaller and slope the pipes more shallow. Therefore the depth of the grid floor system would be reduced to about one foot.

Instead of having the supply ducts in every column, I will use the supply duct in another column, that will make it easier to place the duct and it will save more of the insulation materials.

Because of the low velocity system, we need the radiators around the outside part of the building to provide heat during the winter. One radiator per every two window bays, 10 ft.. The radiators are placed erect on the floor and are to be hidden by the exterior wall panels.

The air handling units,

The refrigeration unit,

Boilers,

Pumps and

Generators

are all located in the basement.

Also the main electric closet

the main telephone closet and

the main mailbox

are all located in the basement.

On the top floor we only locate

the air handling units

the refrigeration unit and

the boilers.

The fresh air will be taken in from the outside of the building by another fresh air chimney near the building. This chimney can be designed in a sculpture form or in some other form that has the relationship with the main building.

The cooling towers are located on the top of each core, and freeing the roof space for exterior research and activities.

INTERIOR PARTITION

The most flexible element in the building is the interior partition. So we have to design the load more lightly in order for the people to be able to move it. The partitions are solid and can be done as a module by the use of the same grid floor module 5'. Every module partition is five feet by eight feet high, and two more feet can be used at the top part to be filled in by the glass to reach the underside of the grid-ceiling. Another kind of the module partition is five feet by ten feet high- from the floor to the underside of the grid ceiling. This kind of partition can be used for some rooms whose function needs the solid wall.

The solid element may be any material that is not very heavy- wood, metal or masonry. The partitions that are necessary are 6" thick- in order to have the insulation, accoustic material, and to have enough open space inside the partition panels for the running of some pipes if necessary.

The spaces of the holes inside the floor slab also can be filled in by some precast concrete panels and by the plastering in of the areas if the utilities penetrate the spaces.

EXTERIOR WALL ELEMENTS

All exterior walls are precast concrete and glass windows, every precast concrete wall is designed for hiding the radiators. The verticle fins are not only for sunshade but they also provide the five feet module windows, both for human scale and for the interior partition to take place.

EXTERIOR EXPRESSION

The building is ten stories high including the mechanical at the top floor. The expression of the pinwheel system can cut down the 345 feet long facade of the building and makes it become more on the human scale. Every element of the building is the result of the growth system, the structural system, and the economic system. That makes the building become more alive in the fact that it can be expanded in any direction, and it has unlimited area. The ten stories high, the four or the two stories high will never change the form of the main building.

CONCLUSION

In conclusion, after the period of studying this thesis "Building as Systems", all of the problems are solved and are over ambitious. The design becomes clear.

All the contributions and advantages of this thesis-

- A. The systematic approach as a basis for designing the building.
- B. The modular system of the unit gives unlimited expansion.
- C. The grid floor structural system is the most advantageous for a scientific and technological development building.
- D. The modular structure provides the horizontal and vertical flexibility.
- E. An architectural expression of the structure uniquely tailored to precast concrete construction, can provide a visual richness of scale and an exposed structure system.

BIBLIOGRAPHY

Kepes, Gyorgy. editor. Structure in Art and in Science. New York: George Braziller, Inc., 1965.

Kepes, Gyorgy. editor. The Visual Arts Today. Middletown, Connecticut: Wesleyan University Press, 1960.

Reinforced Concrete Construction " Grid System "
Grid Flat Slab Corporation, Boston, Mass. 1965.

" Drama of Life before Birth " Life, April 30, 1965
p.p. 54-72A.

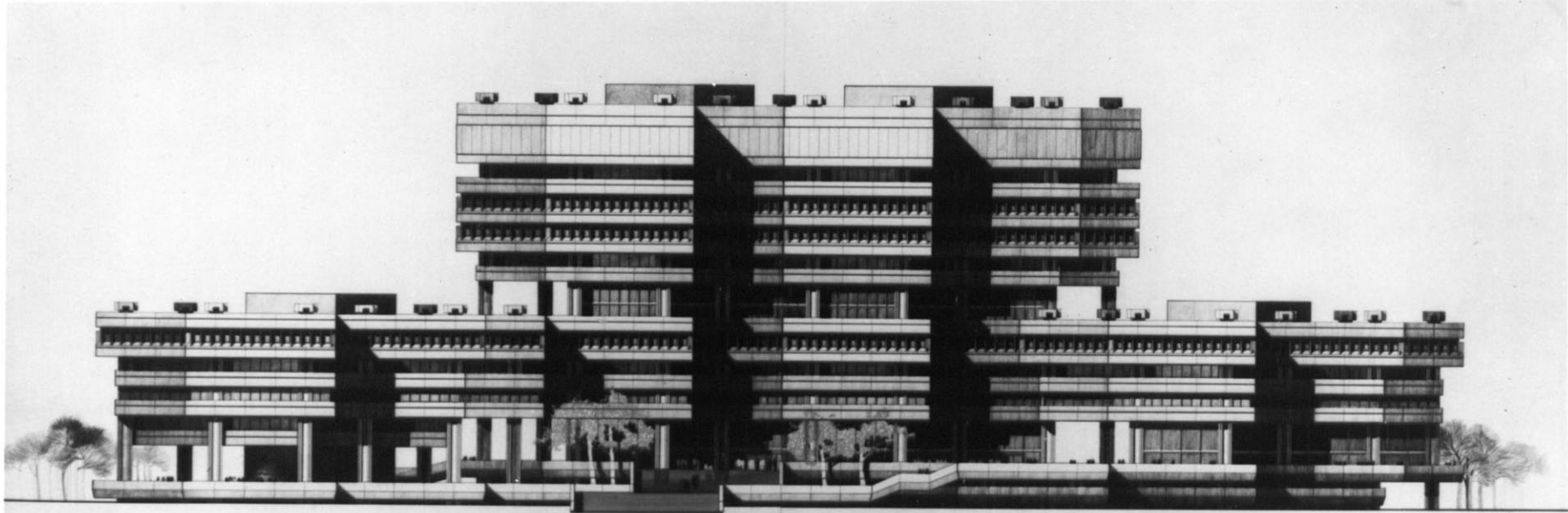

ELEVATION
1:100

BUILDING AS A SYSTEM
MASTERS IN ARCHITECTURE
N. I. T.
JUNE 1965
ALAN S. FRIEDMAN

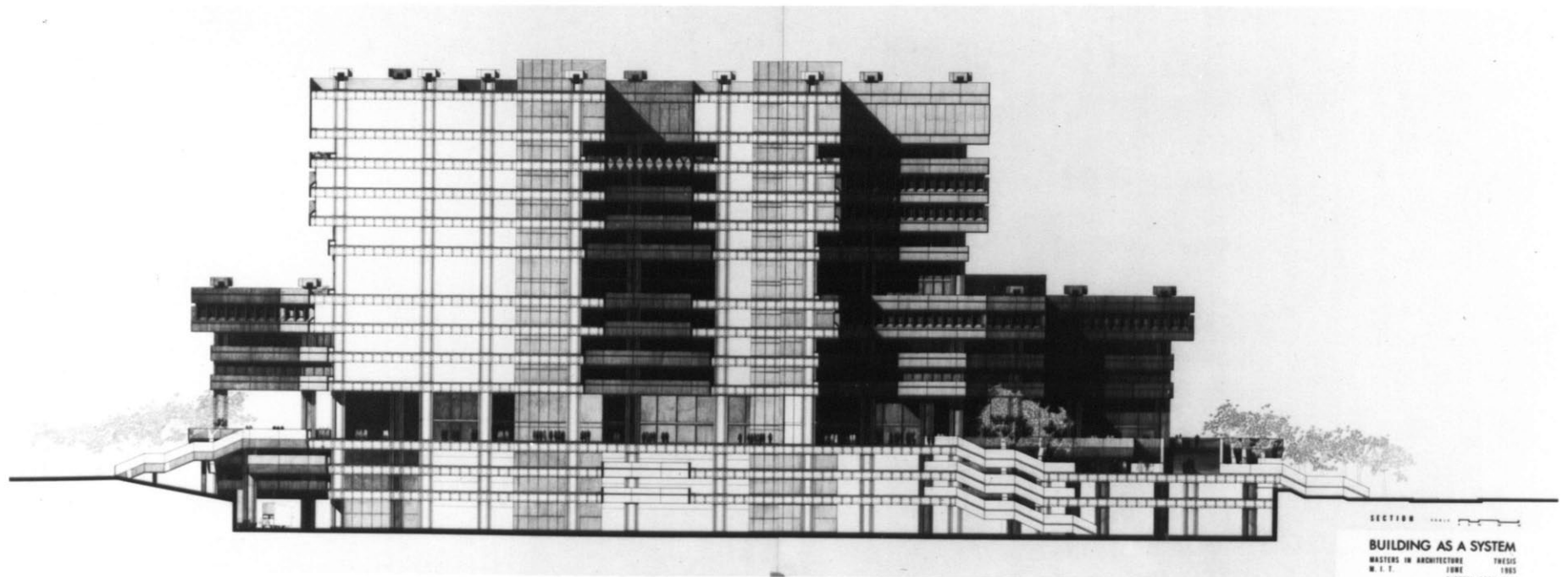

SECTION

BUILDING AS A SYSTEM

MASTERS IN ARCHITECTURE THESIS
M. S. F. JUNE 1965
KUNGLIGA TEKNISKA HOGSKOLEN

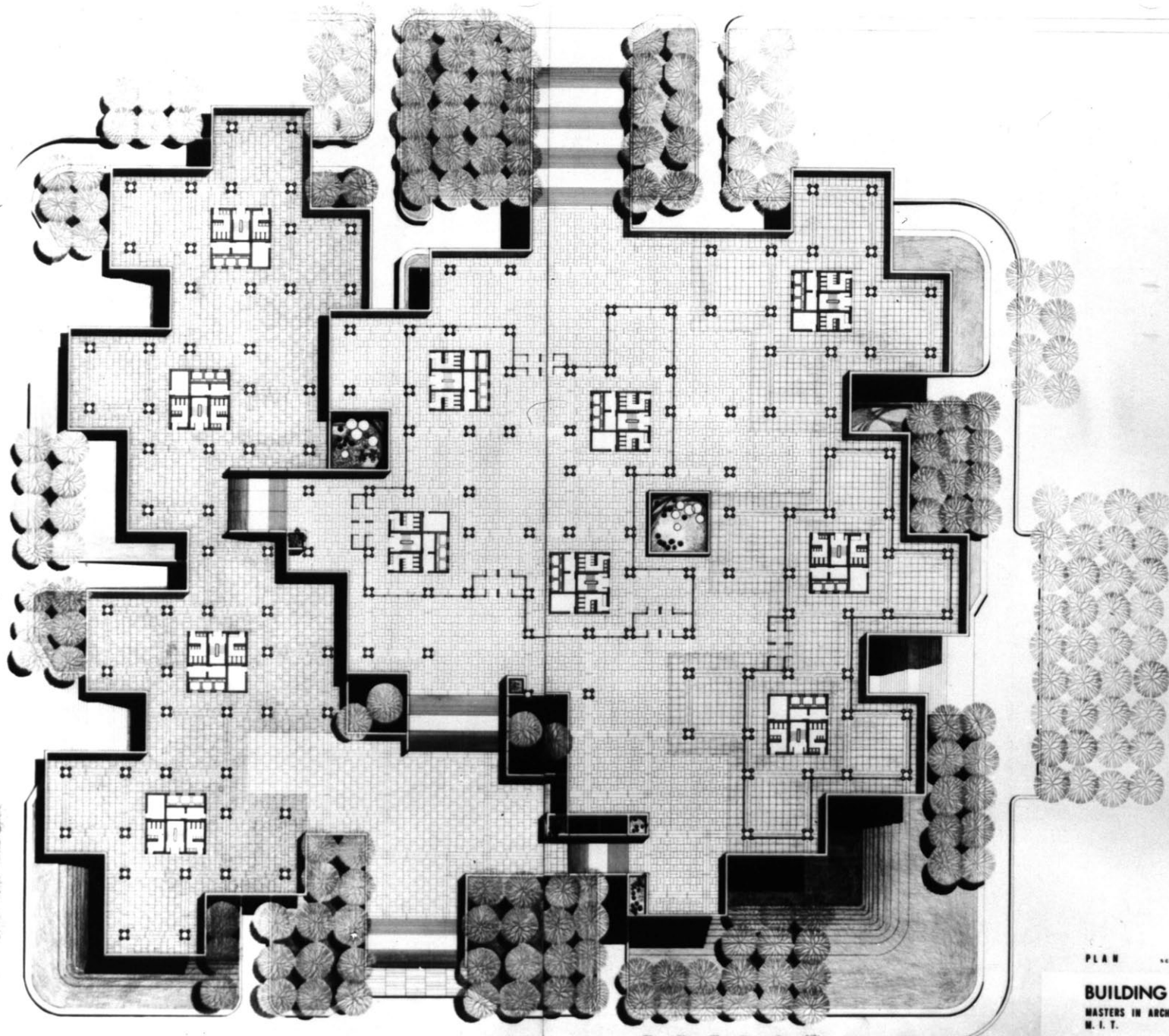

PLAN SCALE 1/8" = 1'-0"

BUILDING AS A SYSTEM
MASTERS IN ARCHITECTURE THESIS
M. I. T. JUNE 1965
KUNGSAN YONGSWAN

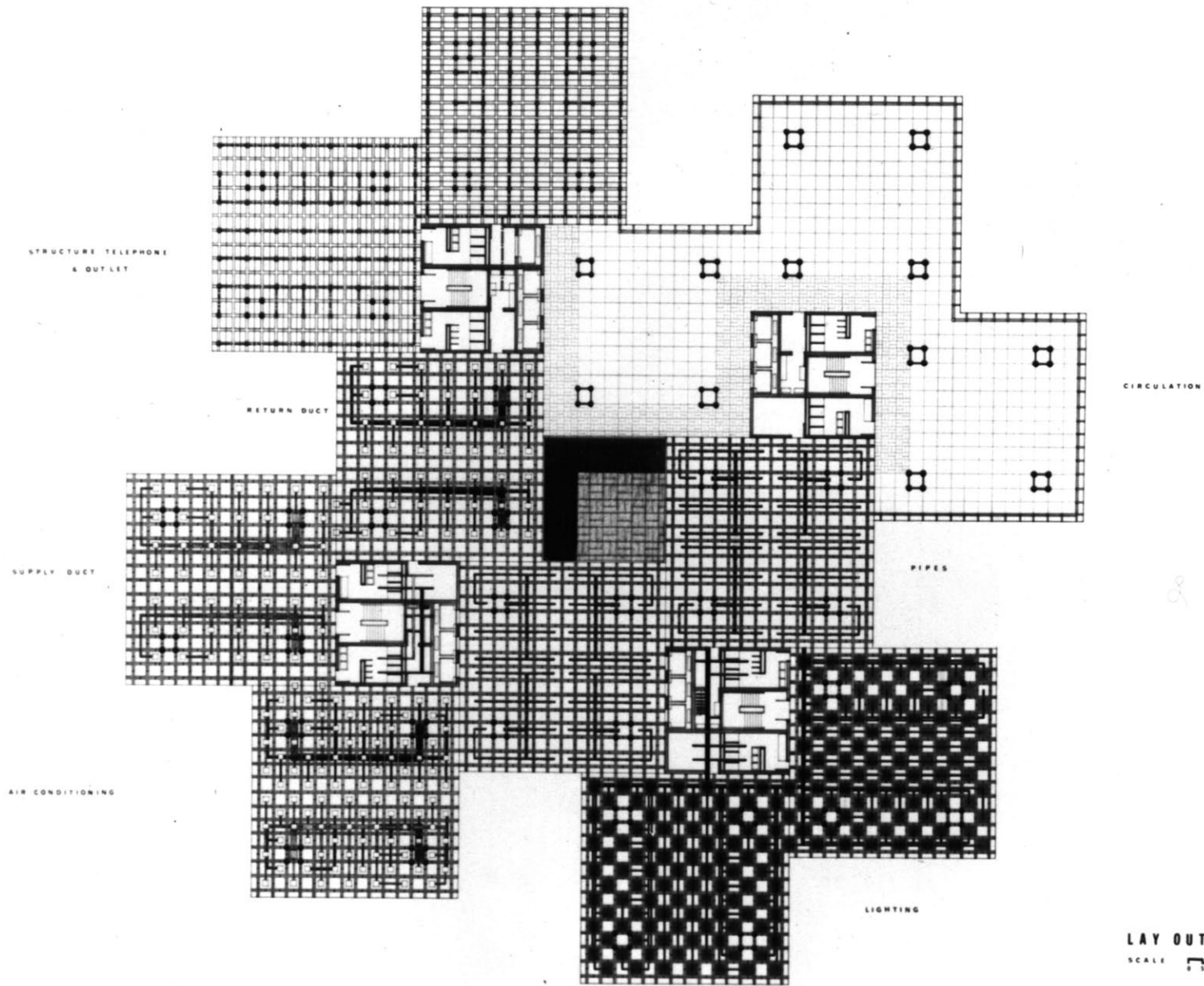

BUILDING AS A SYSTEM
 MASTERS IN ARCHITECTURE THESIS
 M. I. T. JUNE 1965
 RJNGSAN TORSUWAN

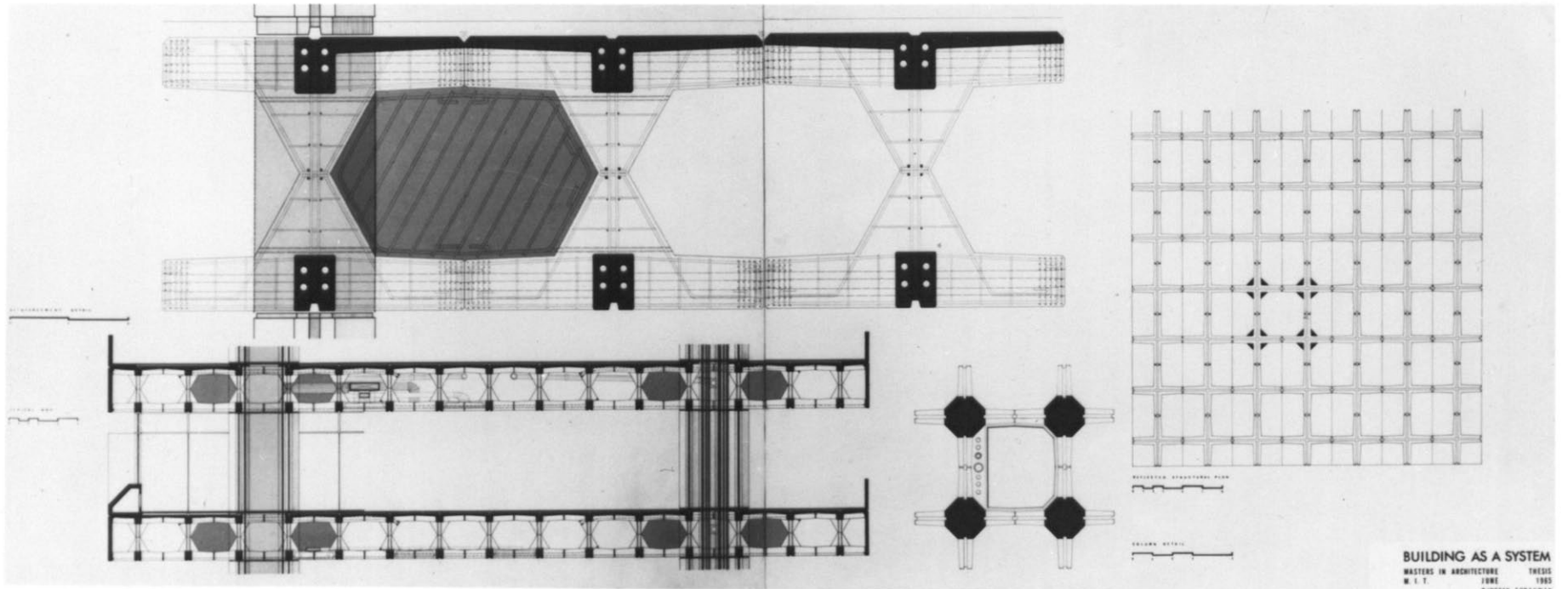

BUILDING AS A SYSTEM
WALTERS IN ARCHITECTURE THESIS
M. I. T. JUNE 1985
RUSSELL TROSKAN

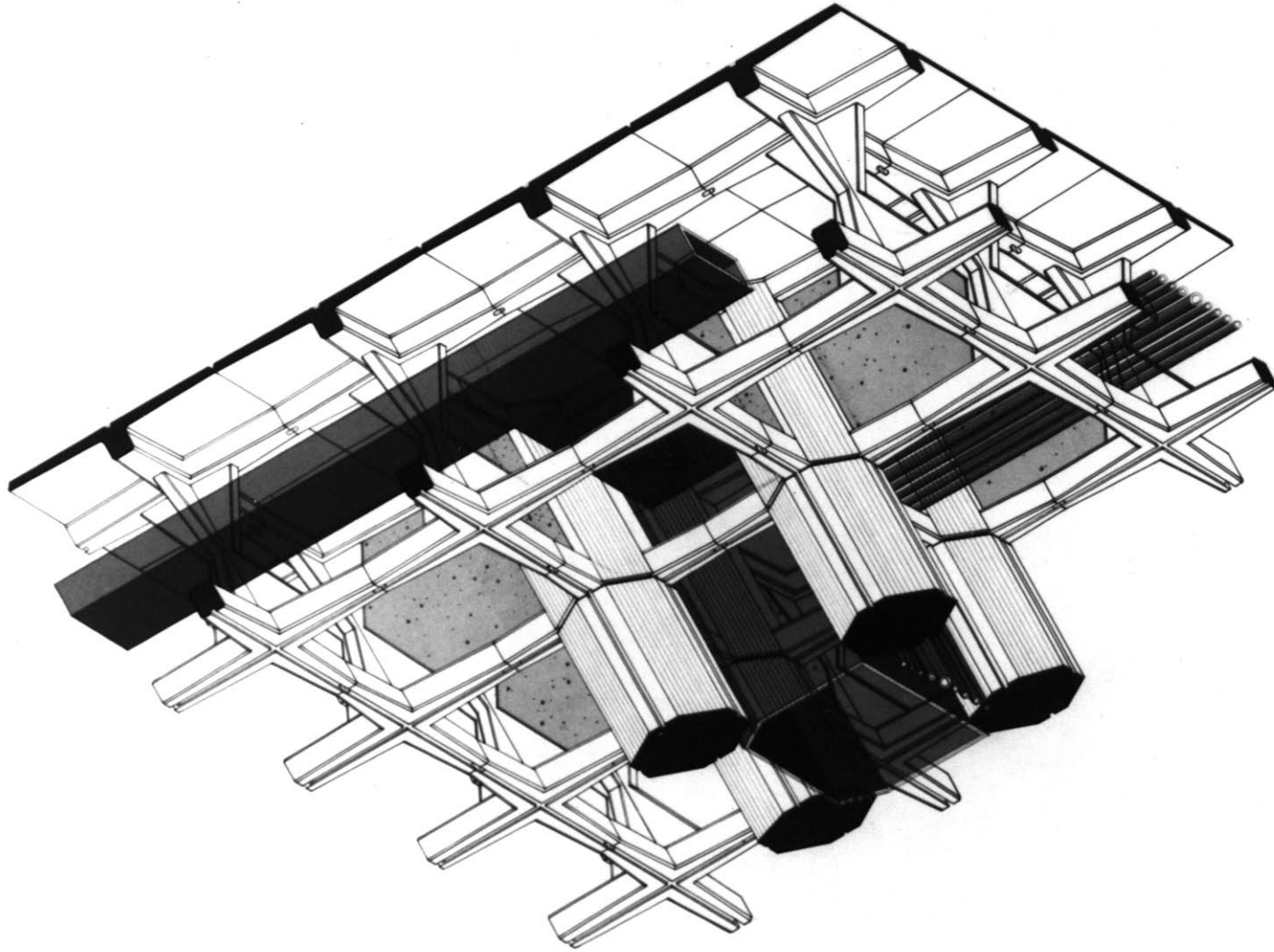

BUILDING AS A SYSTEM
MASTERS IN ARCHITECTURE THESIS
M. I. T. JUNE
RUNGSAN TORSU

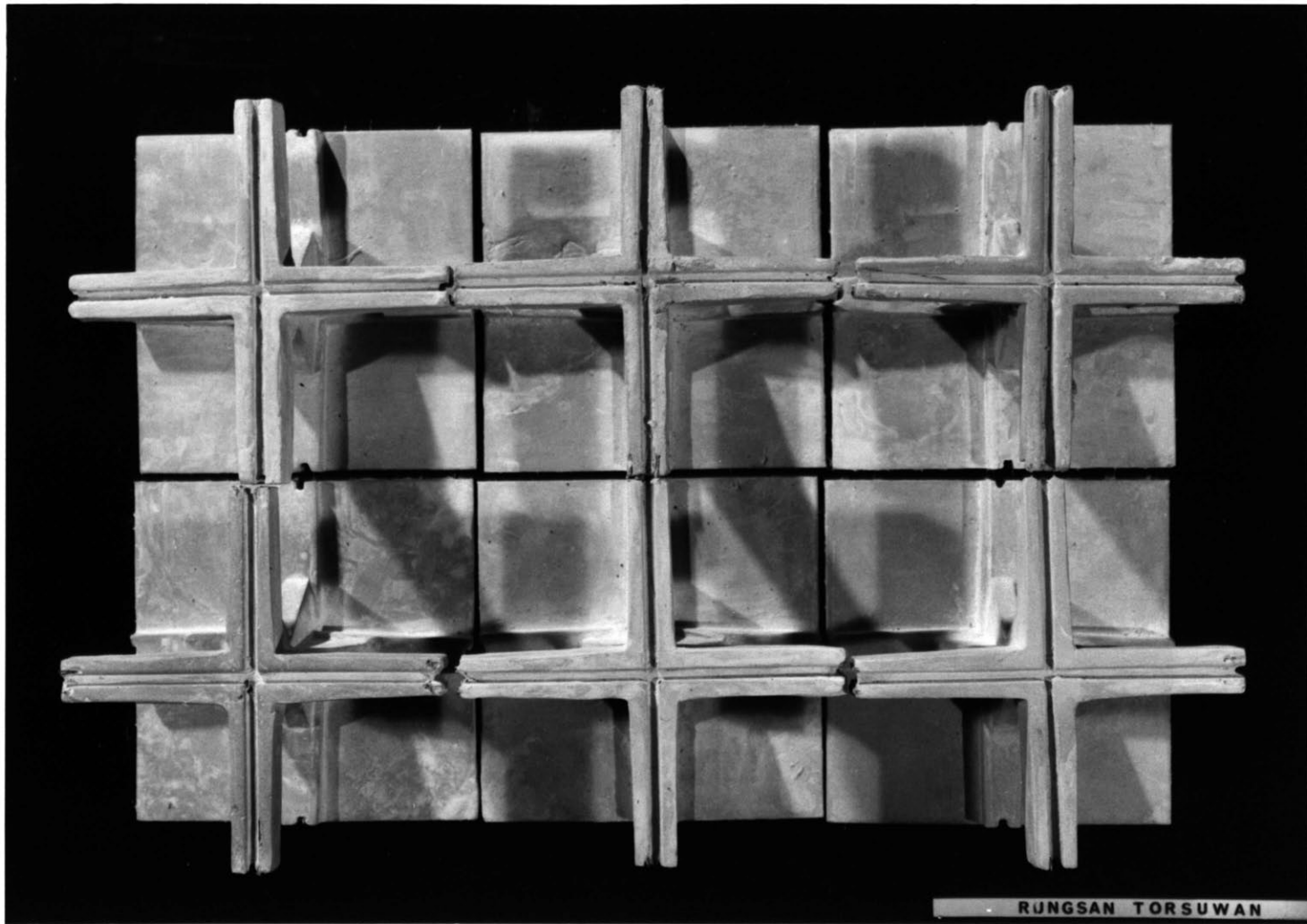

RUNGSAN TORSUWAN

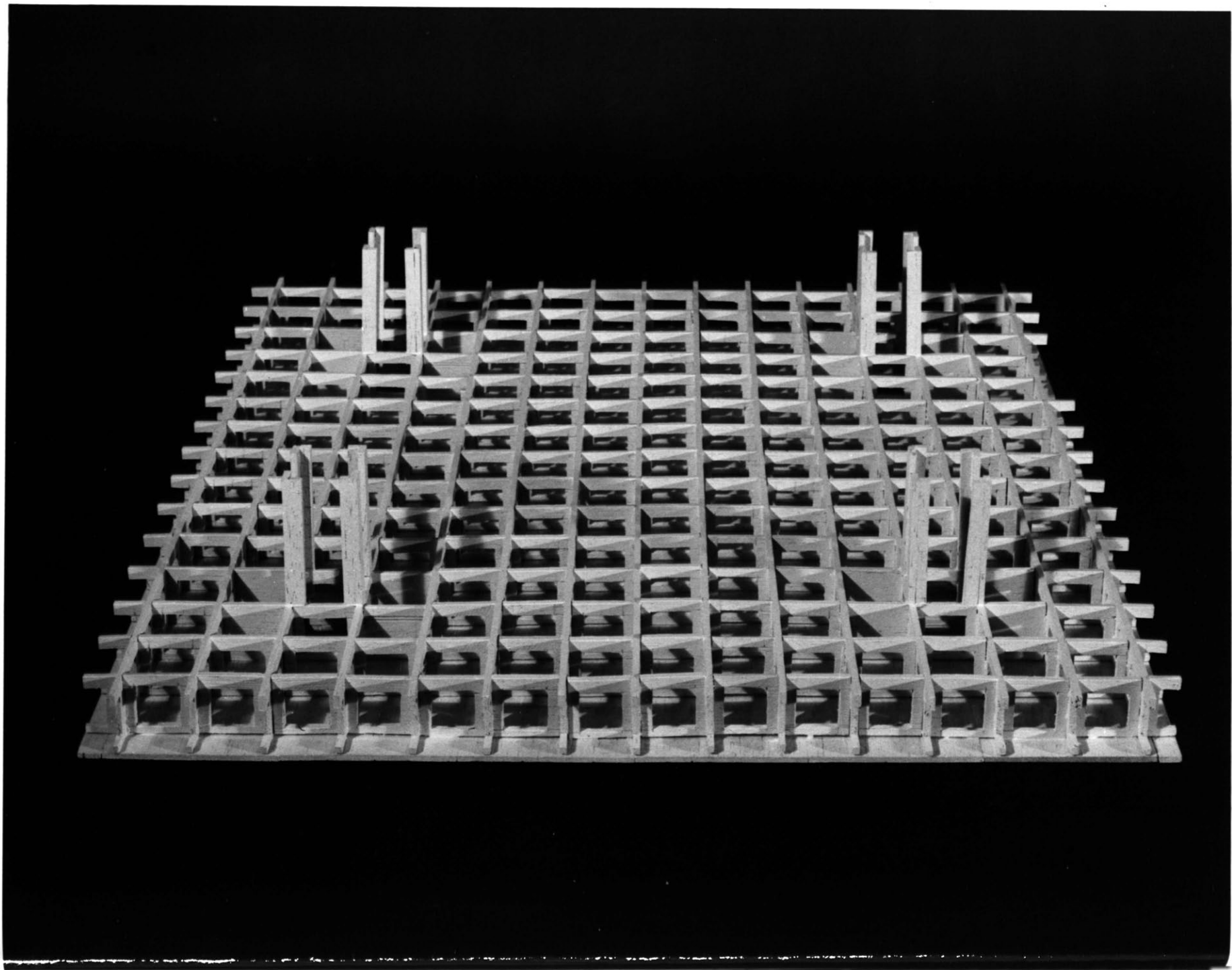

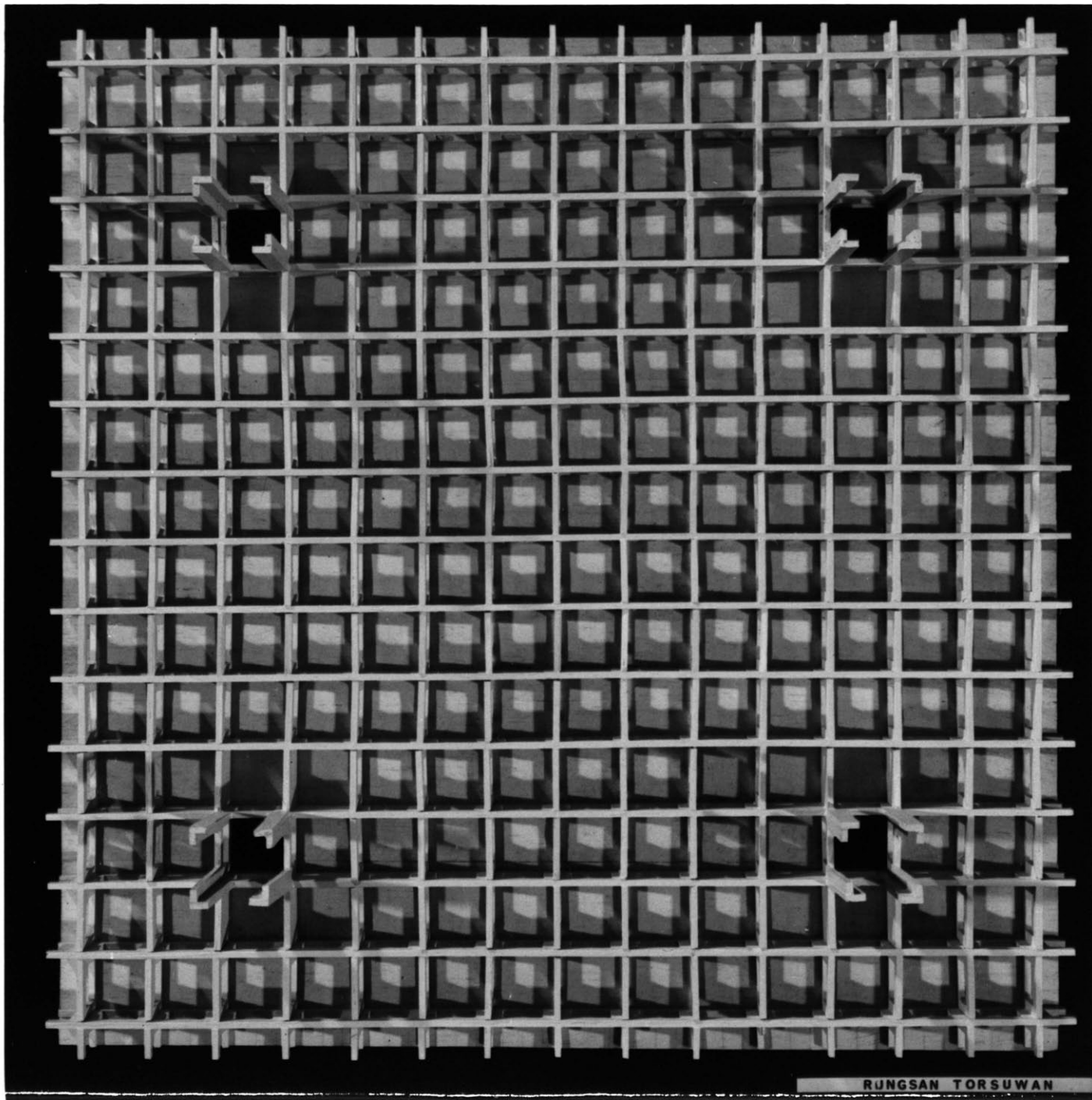

RUNGSAN TORSUWAN

