

WALKING ON DAYLIGHT:
the application of translucent floor systems
as a means of achieving natural daylighting in
mid and low rise architecture

By
JAMES WIDDER

Bachelor of Architecture with distinction
University of Minnesota
Minneapolis, Minnesota
1978

SUBMITTED TO THE DEPARTMENT OF ARCHITECTURE
IN PARTIAL FULFILLMENT OF THE REQUIREMENTS
OF THE DEGREE MASTERS OF SCIENCE
IN ARCHITECTURE STUDIES AT THE
MASSACHUSETTS INSTITUTE OF TECHNOLOGY

JUNE, 1985

© James Widder 1985

The author hereby grants to M.I.T.
permission to reproduce and to distribute publicly copies
of this thesis document in whole or part.

Signature of
the author

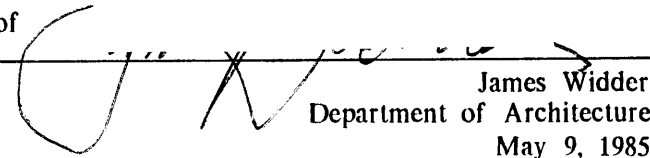
James Widder
Department of Architecture
May 9, 1985

Certified by

Timothy E. Johnson
Principal Research Associate
Thesis advisor

Accepted by

Julian Beinart
Chairman Departmental
Committee for Graduate Students

MASSACHUSETTS INSTITUTE
OF TECHNOLOGY

Rotch JUN 03 1985

LIBRARIES

WALKING ON DAYLIGHT: the application of translucent floor systems as a means of achieving natural daylighting in mid and low rise architecture

by James Widder

Submitted to the Department of Architecture on May 9, 1985 in partial fulfillment of the requirements for the degree of Masters of Science in Architecture Studies

ABSTRACT

This thesis is concerned with the introduction of quality daylight to buildings by means of translucency in the horizontal planes or floors within the building. Since people began to build, the concept of translucency in the vertical planes, the walls of a building, has served as the basis for continual invention in structural systems and the translucent component or window itself. This thesis pursues the application of translucent floor systems as an alternative or additional means of achieving daylighting in this same vein.

This thesis begins by tracing and elaborating on the early historical precedence for this application. It then proceeds to explore the properties of the various types of daylight admitted through horizontal openings and its behavior in relationship to the properties of the translucent floor construction. Through a series of physical daylight modeling techniques, basic relationships are established between the parameters of the translucent floor system and the resultant quality and quantity of daylight in the building. The basic structural systems employed in this technology are investigated and evaluated with respect to translucency of the system. The compatibility of floor translucency to various programmatic and organizational characteristics of the building is assessed. This thesis concludes by demonstrating the application of the translucent floor system to achieving daylighting in three prototypical architectural projects covering a diverse range of building types.

Thesis Advisor: Timothy Johnson
Title: Principal Research Associate

ACKNOWLEDGEMENTS

I would like to express my gratitude to the following people and companies without whose support and assistance this thesis would never have come to fruition:

The Pittsburgh Corning Corporation which donated glass block for full scale testing purposes.

The Circle Redmont Corporation which provided invaluable technical assistance and donated material for testing.

Professor Harvey Bryan for his thoughtful advice and architectural guidance.

Professor Timothy Johnson for his constant guidance and enlightening suggestions throughout the writing of this thesis.

TABLE OF CONTENTS

ABSTRACT _____ 2

ACKNOWLEDGEMENTS _____ 3

INTRODUCTION _____ 7

Chapter 1
A LIGHT FROM THE PAST _____ 12

- Wooden Hatches
- Material Properties
- Cast Iron
- Glass Lenses
- Glass and Concrete
- Plate Glass
- Local Examples
- Formal Qualities
- Recent Examples
- Glass and Steel House
- Propylaeum

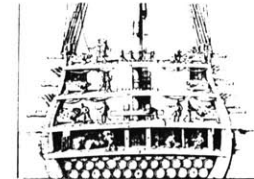

Chapter 2
NATURE OF DAYLIGHT _____ 23

- Clear Sky Condition
- Partly Cloudy Sky Condition
- Overcast Sky Condition
- Daylight Reflection
- Daylight Transmission
- Interior Reflectance
- Daylight Refraction

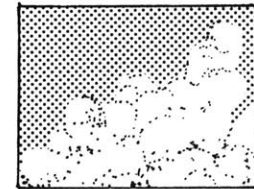

Chapter 3

MODELING DAYLIGHT PROPERTIES OF TRANSLUCENT FLOOR SYSTEMS_32

Modeling Program

Modeling Methods

Modeling Procedure

Modeling Apparatus

Experimental Procedure

Daylight Standard

Modeling Results

The Relationship of Daylight Factor to Wall Reflectance and Room

Cavity Ratio

The Relationship of Daylight Factor to Light Transmission of

Floor Light

The Relationship of Daylight Factor to Aperture of Floor Light

and Skylight

The Wall or Corner Effect

Light Shelf Profiles and Finishes

Floor and Side light Combinations

Light Between the Walls

Conclusions



Chapter 4

TRANSLUCENT FLOOR STRUCTURAL SYSTEMS_____ 55

Glass and Concrete

Glass lenses

Composite Testing

Strengthened Plate Glass and Structural Steel

Conclusions

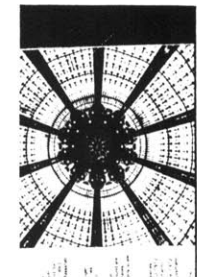

Chapter 5	
CONCEPTS OF INTEGRATION WITH ARCHITECTURE	67
Architectural Systems	
Space for Daylight	
Daylight and Space	
Scheduling and Daylight	
Daylight and Building Economics	
Mechanical and Electrical Systems	
Artificial Lighting	
Life and Fire Safety	
Floor and Ceiling Finishes	
Acoustical Properties	
Solar Gain and Thermal Comfort	
Conclusions	
 Chapter 6	
ARCHITECTURAL PROTOTYPES	85
Urban Rowhouses	
Lowrise Commercial Office Building	
Freeport Middle School	
 CONCLUSIONS	115
 FOOTNOTES	124
 APPENDIX A	126
 BIBLIOGRAPHY	157

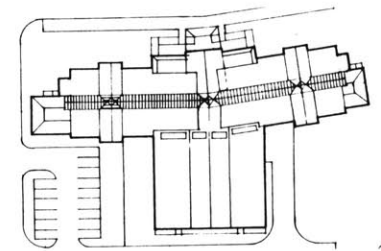

INTRODUCTION

Daylight is one of the fundamental shapers of architectural form. The play of light along a building's surfaces, both inside and out, and the quality of this penetration is the medium in which architecture is experienced.

Daylight does not stop at the wall, because openings are carved away to see out and to bring daylight and fresh air in. In some case the wall is eliminated altogether and only the frame is expressed creating vast openings of view and light. The fenestration, or the way in which architects seek to carve these openings is essential to the development of style, composition, symbolism and luminous and thermal engineering.

Daylight does not stop at the roof because openings are carved away in this surface as well to let the light pour into the space within the shell of architecture. When the roof is carved away, out or back and the next floor and a certain number of succeeding floors are likewise carved away, a great light court, cortile or atrium is formed.

The great sacrifice with such a form has always been the trading of space for daylight. Although the atrium or light court has been successfully employed throughout history and is certainly very satisfying architecturally, the pressing densities



Fig. 1. Galleria Umberto, Naples, E. di Mauro, 1887-1891

of modern urban and suburban centers, the increasing demand for affordable space and the need for light set the stage for a different, revolutionary form of integration of light, structure and space.

The goal of real resource conservation in low and midrise commercial and institutional architecture has also shifted the focus from thermal comfort to the visual quality and the luminous environment for work, study, living and recreation. The selection of roof and wall fenestration and the associated component systems is critical in achieving the goal of a high quality visual and luminous environment. The most drastic impact on energy conservation in this context is achieved through the reduction in electrical costs for lighting needs and a return to a more practical application of natural daylighting principles in planning and architecture.

How does the architect reconcile a path back to practical daylighting methods with the pressing demands of affordability, building economics, suburban and urban densities and the need for light "and" space, not light at the expense of space? This thesis considers the possibility of integrating space and light in the floor of skylit rooms or corridors and for succeeding floors as a viable means of achieving natural daylighting which takes into account these various demands.

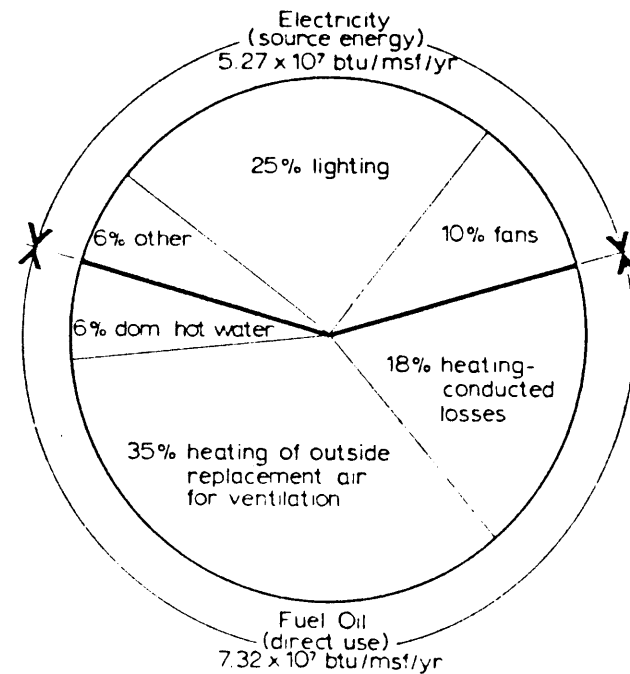

Fig. 2. The average energy use pattern (in BTU per year) for 499 oil-fired schools in New York city public school system.

The concept of translucency in the floor is by no means a new idea. Since the early nineteenth century and the development of structural and tempered glass, cast iron grating and associated technology, this approach has been applied many ways, sometimes in conjunction with the more conventional daylighting techniques of the atrium or light court. This thesis will explore and elaborate on the historical precedence for translucent floor technology and will trace its evolution through modern architecture and its diminished use during the rise of artificial lighting.

Beginning with a problem or program statement, the thesis creates a series of hypotheses, which are then tested and modeled. In addition, the issues of integration with other architectural systems and within various appropriate building types are explored and evaluated. More specifically, the technological innovation which this specific thesis pursues arises from the integration of the following program statements:

1. The need to introduce daylight to buildings and allow maximum penetration.
2. The need to maximize usable floor area brought on either by economic considerations, increasing densities or both.
3. The desire to create a unique visual quality of the interior environment.

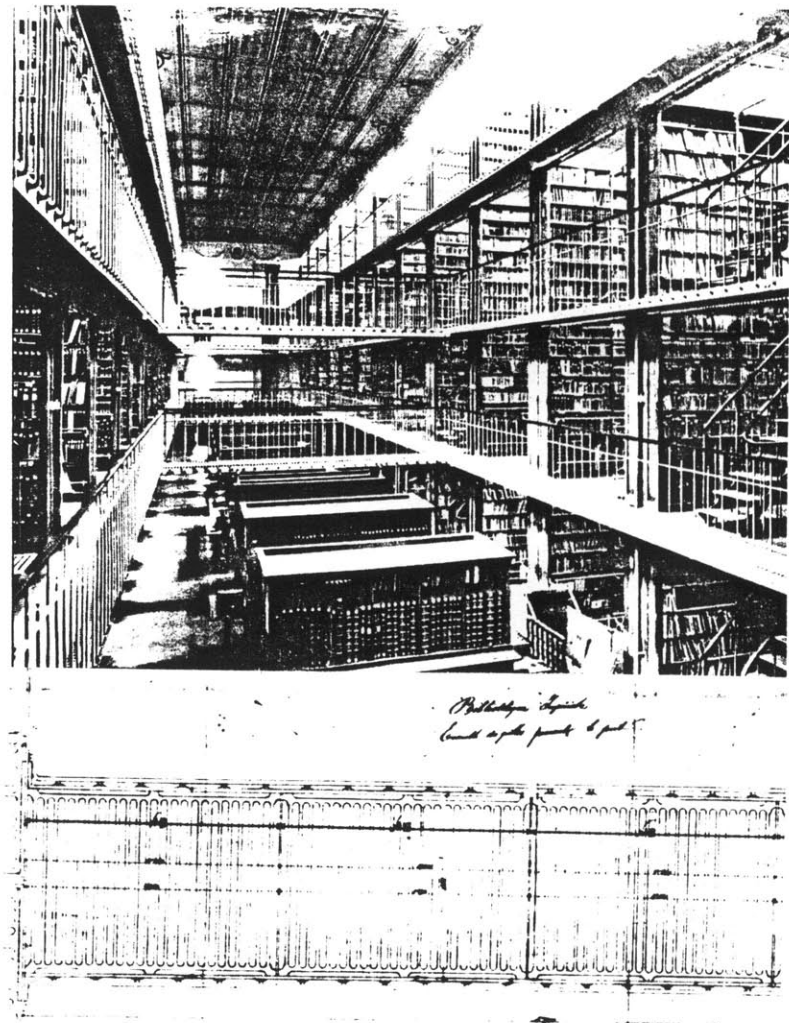

Fig. 3. A plan detail and view of the cast iron floor grating in the stack rooms of the Bibliotheque Nationale, Paris, 1868, by Henri Labrouste.

4. The need to allow for greater visual and acoustical privacy than traditional toplighting alternatives.

5. The need to resolve fire safety issues regarding traditional daylighting concepts of the atrium or light shaft.

Clearly, translucent floor technology should not be viewed as a complete replacement of traditional daylighting concepts, but rather as an alternative when programmatic requirements make the latter unworkable or difficult to accomplish. In most cases this technology may be an addition to conventional concepts of daylighting, serving to augment the performance of these systems.

With these program statements in mind, this thesis begins to explore the historical precedence of the translucent floor system and the various conditions which gave rise to it. In order to understand the potential of this technology, the nature of daylight is considered. The various kinds of distinct sky conditions and their inherent properties are reviewed in general and as they relate to toplighting and floor lighting concepts. The various daylight properties of light transmission, reflectance and refraction are reviewed with respect to translucent floor systems as well as traditional daylighting systems.

This review of the first principle theories of daylight forms the basis for the physical modeling method and procedure.

Within an interchangeable physical model, a number of various floor and skylight apertures and orientations, room reflectances and light redirecting device combinations are tested. These combinations are evaluated and compared on the basis of their relative interior daylight intensities measured in absolute footcandles or a daylight factor. The evaluation of the many combinations leads to an understanding of various design principles in the application of floor lights.

Finally, in applying the floor light to the complex collection of systems which make architecture, the various interfaces of these systems are explored and evaluated. This exploration ultimately leads to a series of architectural design examples which demonstrate an integrated solution for the application of translucent floor technology in various appropriate building types.

Chapter 1

A LIGHT FROM THE PAST

Over the millenia, whenever both space and light were at a premium, the concept of translucent paving emerged as a feasible invention. Whether it was in the congested markets of old England or the confined decks of ancient sailing vessels, inventors struggled to pass essential daylight through traffic bearing surfaces to the spaces beneath.

WOODEN HATCHES

Prior to the development of sophisticated cast iron and glass making technology in the beginning of the nineteenth century, the earliest recorded application of light transmitting decking occurred in the design of wooden sailing vessels of Europe and America. The two-way wood grating system consisting of interlaced and notched wood beams spaced two to four inches apart was placed at various hatches along the uppermost deck to daylight and ventilate the decks beneath. During heavy weather these gratings were covered with tarpaulins to prevent the entry of sea water.⁽¹⁾

MATERIAL PROPERTIES

It is not surprising that there is no earlier precedence for this technology as, with the exception of wood as a material, no other natural materials, i.e. cut stone, or brick,

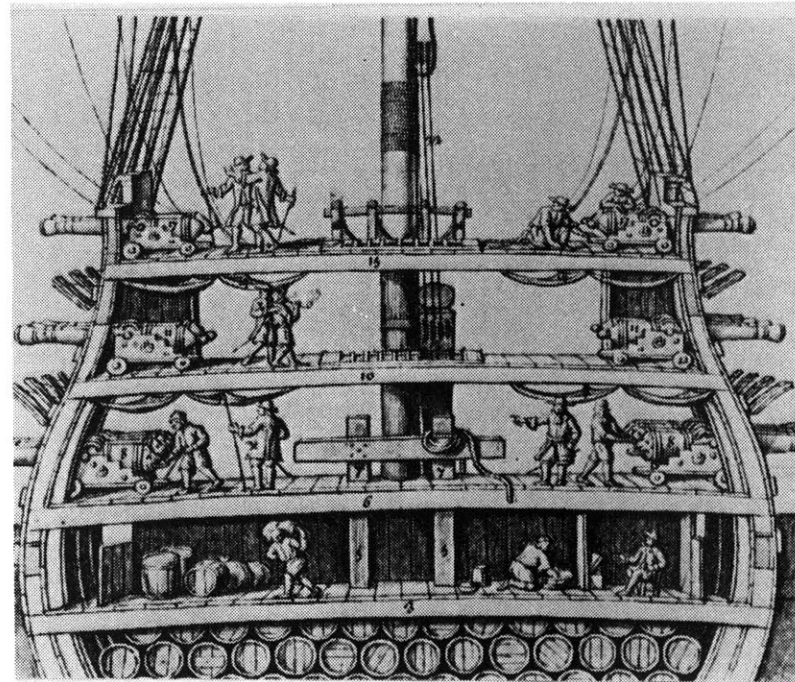

Fig. 4. Early wooden sailing vessel of seventeenth century European fleet showing wooden grid in hatchway for daylighting.

could obtain the efficiency of structure which would allow for the sufficient transmission of light through load bearing floors.

CAST IRON

In the early nineteenth century, with the revolution in the production of cast iron building components, there emerged another material which possessed the necessary structural properties to allow for the combining of translucency and structure.⁽²⁾ The original application of cast iron grating for this purpose did not yet provide for complete enclosure of the space below but rather relied on the mere open perforations to provide for the necessary transmission of light. It should be noted however, that this feature provided for the added function of ventilation through the floor components. Nevertheless, this type of translucent grating was extensively used to provide for the maximum penetration of daylight to the spaces beneath. The most notable example of this application is in the Bibliotheque Nationale in Paris, 1858-68. Here Henri Labrouste, the architect, used simple cast iron grids for the floors in the stack room, thus admitting light to the shelves from top to bottom.⁽³⁾

GLASS LENSES

Well before this time however, Pallat and Greene of England had invented "glass illuminators" "... for admitting daylight into the internal parts of ships and buildings..."⁽⁴⁾ Major advances in the refining, annealing and, pressing of

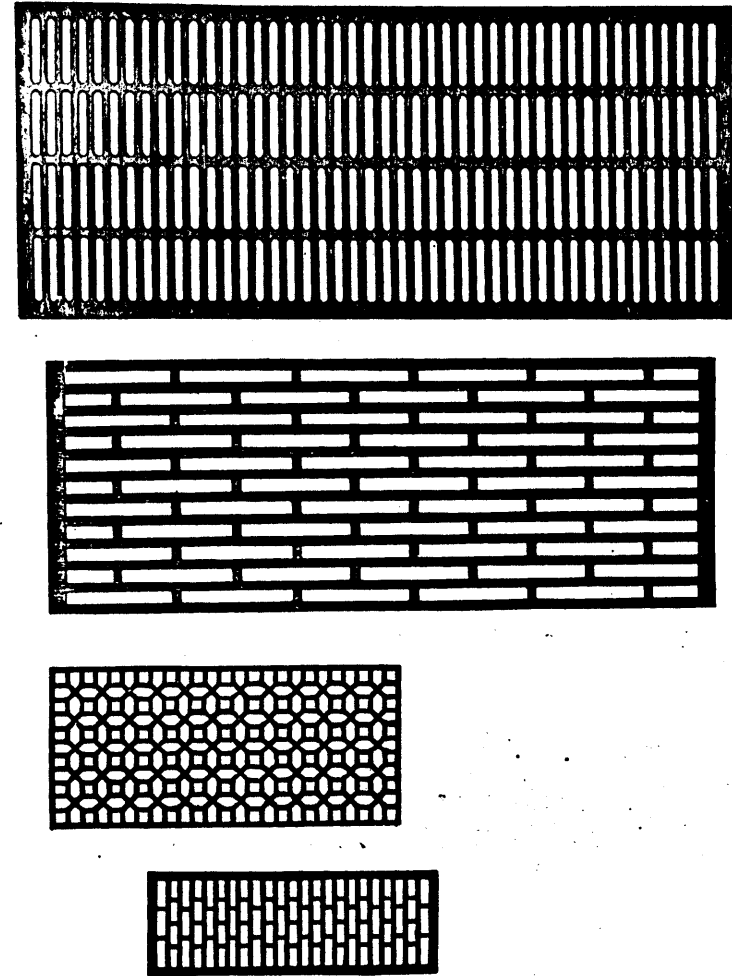

Fig. 5. Various cast iron grate patterns from the mid nineteenth century used for ventilation and daylighting.

glass lenses had, by this time, brought glass as a material to a point suitable for use as translucent paving. Several types of glass paving prisms were developed which took advantage of the light redirecting property of glass.⁽⁵⁾

GLASS AND CONCRETE

Much of the early work in this area was advanced by the German architect Frederick Keppler, the inventor of the "Keppler System" for a glass and concrete floor and roof construction in 1907.⁽⁶⁾ With this invention he founded the Deutsche Luxfer Prismen Gesellschaft company which was responsible for further improvements on the original system. Specifically, this system consisted of two-way reinforced concrete ribs cast in situ about the glass lenses. The overall depth of these original lenses varied from 40 to 65 mm and representing the total thickness of the assembly. Later improvements on this system led to even thinner lenses with the reinforced concrete ribs cast about and projecting beneath the glass lenses.

Almost concurrent with Keppler's work is the development of the French system for translucent paving "Le beton translucide" by Joachim in 1908. In contrast to the German system where the use of relatively shallow lenses led to a system which insulates the glass from the structural concrete frames, the French method, employing deep lenses, led to the development of paving and skylight systems in which the glass is fully stressed in compression.⁽⁸⁾ Some of the many

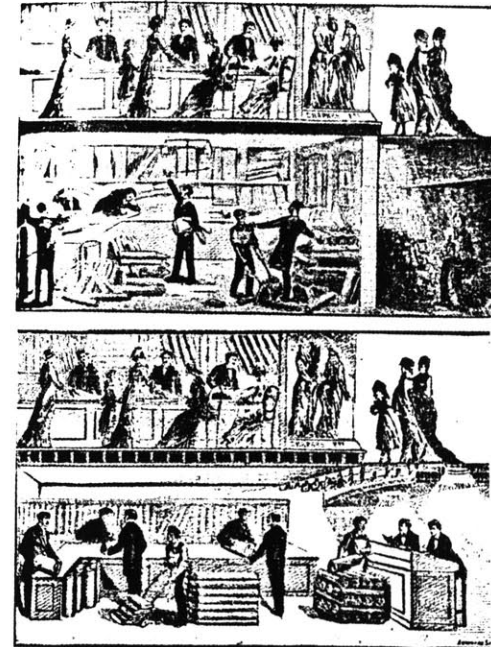

Fig. 6. An illustration of the application of Brothers and Eckstein's glass illuminators in 1897.

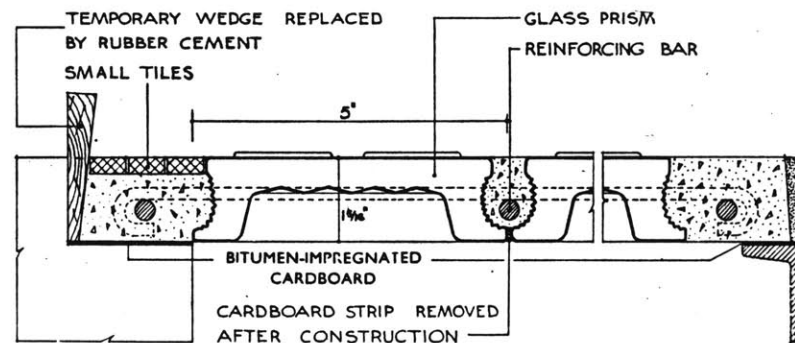

Fig. 7. Construction detail of the original "Keppler" system for glass and concrete floors.



Fig. 8. The Staircase with translucent flooring in the galleries, the Flats in the Rue De Prony, Paris, 1911 by Joachim.

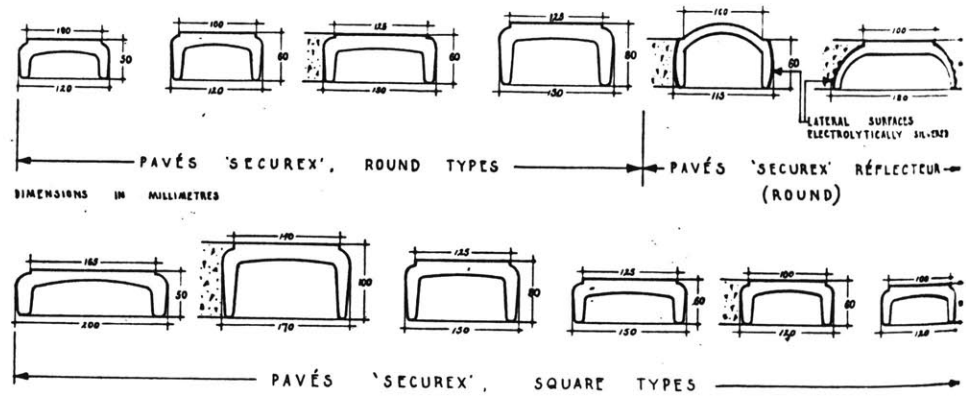

Fig. 9 A variety of glass lenses used by the French in 'le beton translucide' applications around 1910.

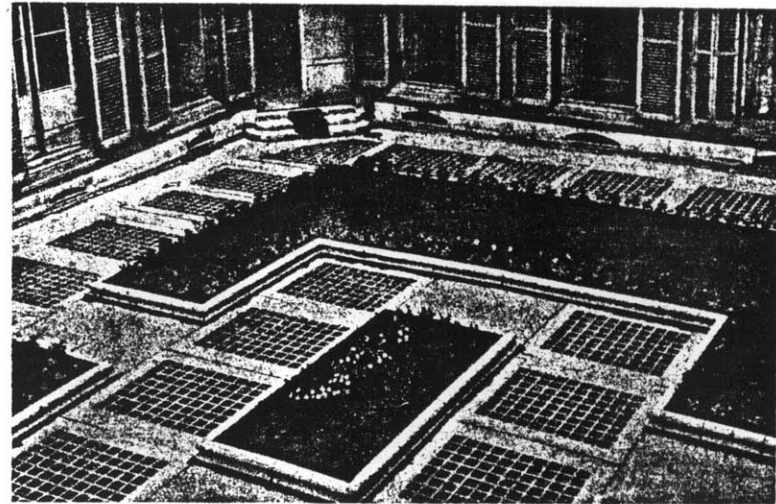

Fig. 10. The translucent pavers in the courtyard of the Credit Foncier de France, 1910.

examples of the employment of the French system include the Gare Saint-Lazare in Amsterdam where lighting of the underground passages of the Nord-Sud is achieved, the Restaurant Ratinaud, Paris, 1911, and the flats in the Rue De Prony, Paris, 1912.

PLATE GLASS

While much of the progress in translucent paving systems centered around the cast or pressed lens placed in reinforced concrete or cast iron frames, there remained other techniques for applying glass to the role of translucent pavement. Probably inspired by Labrouste's novel application of cast iron, many of the library stack rooms as well as some reading rooms, built in the early part of the Twentieth century in Europe and America, utilized a special type of annealed plate glass as the flooring between the cast iron columns of shelving. The plate glass ranged from 1/2" to 3/4" in thickness, often textured with a surface grit or pattern to prevent slipping and supported at their joints by rolled or cast iron beams spanning between the columns of shelving. To prevent localized stress points at the bearing surfaces, the glass plates are set in a bedding of bitumen or other elastic compound. As in the case of Labrouste's earlier example these stack rooms were topped by a magnificent array of skylights as well as extensive sidelighting in many cases.

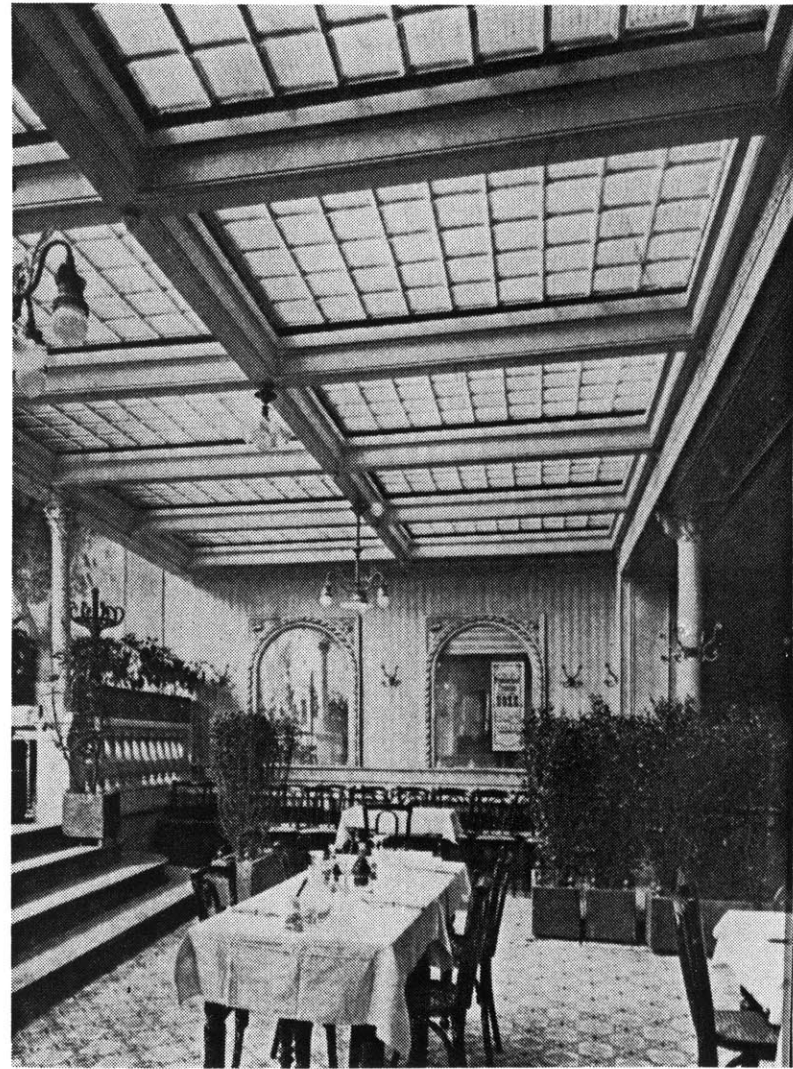

Fig. 11. The Diningroom of the Restaurant Ratinaud by Joachim, Paris 1911. The entire natural lighting was from the luminous ceiling which served as a dance floor above.

LOCAL EXAMPLES

Examples of this application are far too numerous to list, however some local examples include the Boston Athenaeum originally designed in 1847 and later remodeled in 1913, the Widener and Divinity School libraries at Harvard University. Inspection of these installations by the author revealed that with the exception of the addition of electric lighting, the closing off of the important toplighting in one case and, the slight decrease of transmission with wear and age in all cases, the translucent paving is still functioning well in its original capacity.

FORMAL QUALITIES

Apart from the utility of translucent paving for achieving daylighting in buildings, architects have continued to be inspired by the diaphanous quality of this structural and lighting concept. Intuitively, it is an ambiguous concept which is at once solid and void. In 1914 architect Bruno Taut, driven by the idealism of his poetic colleague Paul Scheerbart of the Sturm group, designed the Glashaus for the Cologne exposition.⁽⁹⁾ This building was an exercise in the potential of glass as a building material at that particular point in time. The floors were of glass and concrete construction similar to the French method illuminating a beautiful stained glass ceiling beneath, the roof and walls were also of glass lenses culminating in an incredible translucent stair which winds up and around both sides of



Fig. 12. The fantastic luminous stairs in the Glashaus of the Cologne Exposition by Bruno Taut, 1914.

the pavilion. As much as this pavilion was an exercise in glass as a building material, at the same time it was an expression of Taut's vision of an architecture which is simultaneously both frame and content.'⁽¹⁰⁾ Another architect moved by the unique characteristic of this concept was Giuseppe Terragni of the Italian Rationalist school. In the execution of his design for the Danteum (Rome, 1938) a monument to the epic writer Dante, he sought the use of transparent flooring as an expression of "heavenliness" or paradise in the portion of the monument devoted to those topics in Dante's writings. The forest of one hundred columns which fill the room appear to soar to the sky when in reality they pass through an intervening floor which can be experienced by the viewer. The unique feeling of walking on air or floating which transparent paving would evoke is crucial to the atmosphere of this room.

RECENT EXAMPLES

These several projects noted by no means constitute a complete listing of the many projects which have employed translucent paving over the past several hundred years. They are, rather, representative of the diversity and scope in the evolution of this technology to present time. Some of the more recent projects which have utilized a translucent flooring system in one form or another range from residences to museums. The reasons for creating translucency in the floor are different for each specific project. In some

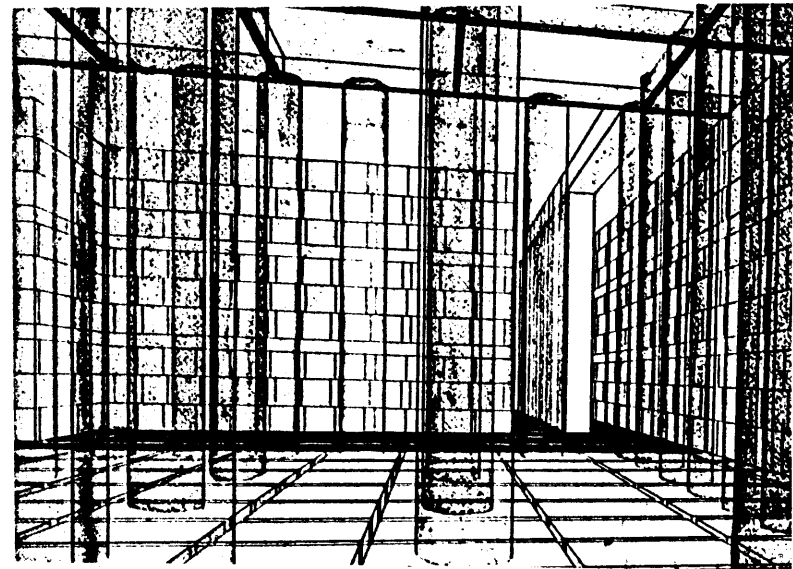
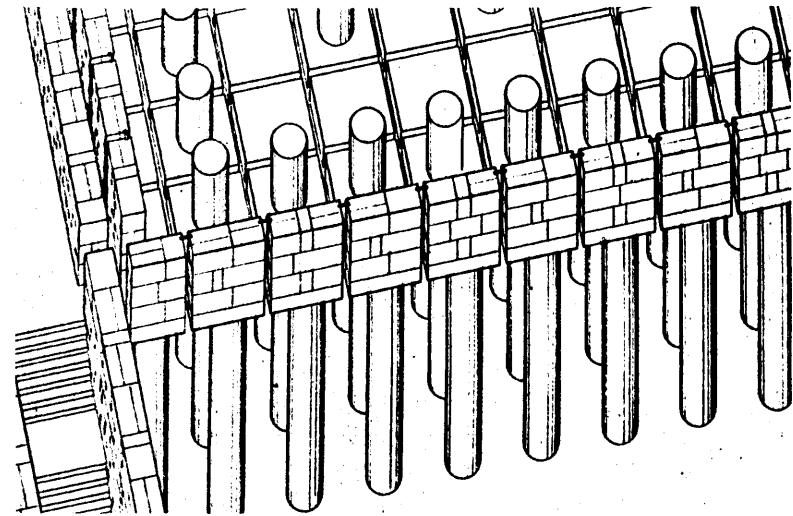

Fig. 13. An isometric view and sketch of the Paradiso portion of the Danteum by Terragni employing translucency in the floor for aesthetic reasons. 1938

cases it is primarily to allow an abundance of daylight to reach further down in to the building and in others it is more of an aesthetic expression of the concept of translucency between building pieces.

GLASS AND STEEL HOUSE

The "Steel and Glass House" (Krueger Residence, Chicago Ill. 1979-80) by Krueck and Olsen employs hollow glass block as a flooring material on a bridge which is adjacent to an exterior curtainwall and spans over the livingroom from one side of the house to the other. The bridge occupies a strip in the house which is likewise topped by a continuous skylight. In an interview with one of the members of the project team it was learned that the translucent bridge was utilized to express the separation of the various parts of the house through the quality of transparency. Here the ambiguous characteristic of translucent paving is brought in to play to function as a solid surface for circulation while simultaneously serving the aesthetic function of a void in the massing of the architecture. This is one of the especially attractive features of this technology.

On a somewhat more pragmatic level, the construction detail of the glass block floor consists of a two-way grid of no. 3 or no. 4 reinforcing steel bars in which the 6"x6"x3"

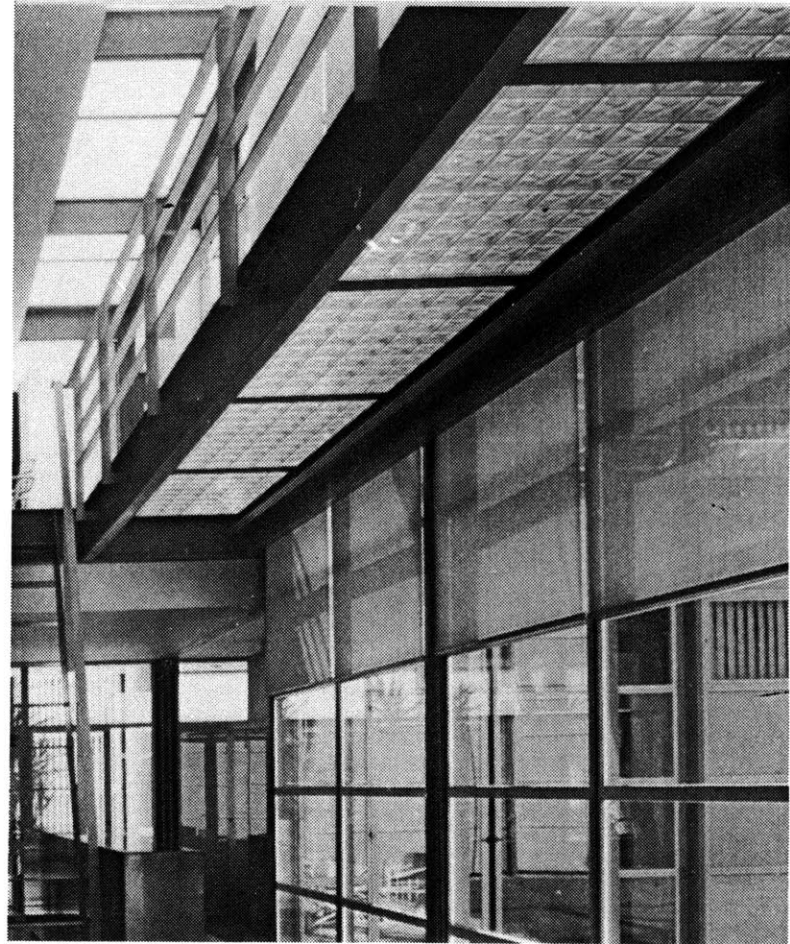

Fig. 14. The glass block flooring in the bridge of the "Glass and Steel House" by Krueck and Olsen, Chicago Ill. 1980

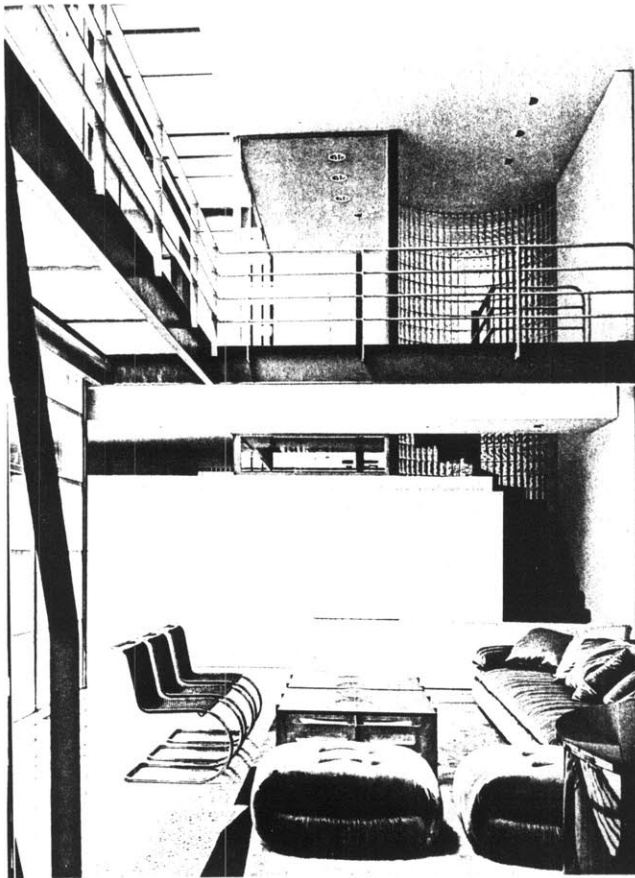

Fig. 15 The Livingroom and translucent bridge in the "Glass and Steel House."

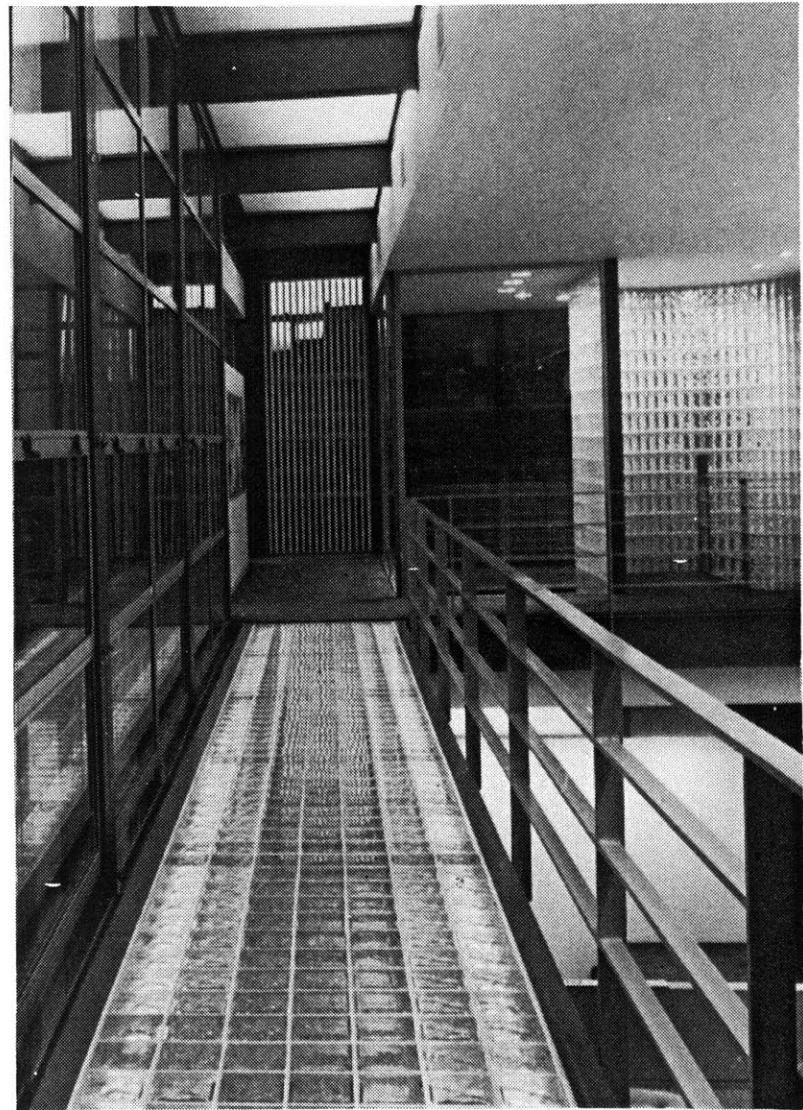

Fig. 16. A view down the glass block paved bridge of the "Glass and Steel House", Krueck and Olsen, Chicago Ill., 1980

hollow glass block is set and grouted solid. A light steel frame is welded to and encloses this grid acting as a compression ring prior to setting the block.

PROPYLAEUM

A special quality of daylight filters down into the lower gallery at the Propylaeum of the Dayton Art Institute (Dayton, Ohio, 1983)by Levin Porter Associates. In this project the concept of translucency is exercised to, in essence, borrow daylight from the large skylit entry hall directly above. This quality simultaneously achieves a rich ceiling and floor pattern in both the lower gallery and the entry hall respectively.

The floor lights used in this project are a descendent of the Keppler system discussed earlier in this chapter utilizing a prefabricated reinforced concrete frame in which the glass lenses are set. These frames inturn rest on ledges in the surrounding concrete structure. The specific lenses used in these floor lights are pressed with a prismatic diffuser pattern on the underside of the lens so as to prevent direct vision as well as to better spread the available daylight around the room.

The technology of the floor light is one which has found application, for the most part, in unique design situations requiring the special characteristics of this concept. It is to

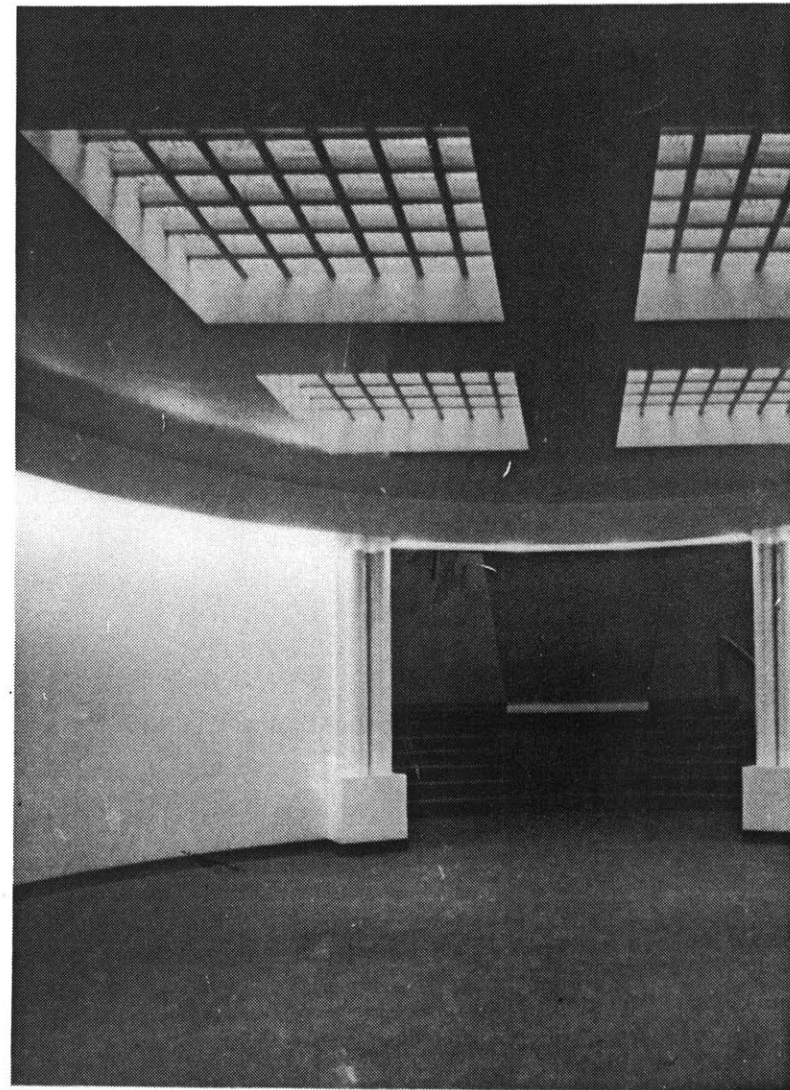

Fig. 17. Lower gallery beneath floor light in the Propylaeum, Dayton, Ohio, Levin Porter Assoc., 1983.

the credit of the early pioneers of this technology that it has found it's way into as much of the architecture as has been presented. As we begin to discover the properties of daylight and the potential of toplighting in buildings the means of employing the floor light will begin to become clear. Futhermore, as some of the age old tradeoffs of making space for light are elaborated, the economy and utility of some of the precedents, which have been presented, will be further realized. It is a light from the past which can light the way to the future.



Fig. 18. Floor lights in entry hall of the Propylaeum, Dayton Ohio, Levein Porter Assoc., 1983.

Chapter 2

THE NATURE OF DAYLIGHT

The nature of the skies is constantly changing. Whether it is the time of day which determines the azimuth and the altitude of the sun in the sky or the the local weather conditions being cloudy or clear, each of these components affect the quality and quantity of daylight. It is this constantly changing characteristic which people rely on for a sense of time and environment and it therefore has an important place in buildings. Although daylight is constantly changing, certain common kinds of daylight can be catagorized. There are three basic kinds of distinct daylighting conditions: clear, partly cloudy and uniformly overcast skies.(11)

CLEAR SKY CONDITION

The clear sky condition is typically seperated into two daylighting components. The first component is direct beam radiation, which emanates from the disk of the sun and is directly related to the position of the sun with repect to the position of openings in the buildings. The second component is diffuse or scattered light which is spread in varying degrees across the rest of the sky. This second component in the clear sky condition predictably participates in toplighting and floor lighting approaches, but it is rather small in comparision to the direct beam component. The

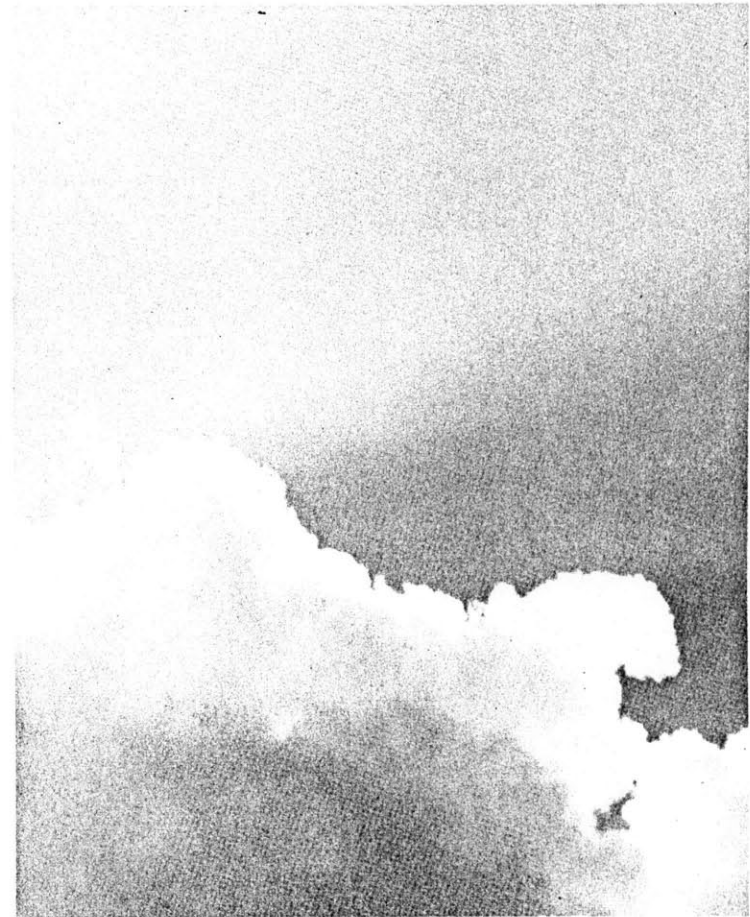

Fig. 19. Two components of daylight: clear sky and clouds.

direct beam component, on the other hand, does participate in these daylighting approaches, but is difficult to predict as its contribution is a function of position and diffuser configuration. The clear sky condition is by far the brightest absolute kind of daylight if the sun is participating in the measurement. The United States Weather Service defines a clear sky condition as one where no more than three out of ten parts of the sky is clouded.⁽¹²⁾ It is characterized by a diffuse sky component which is typically brighter at the horizon than at the zenith and varies only slightly with respect to the position of the sun.

The direct beam component in the clear sky condition is the primary factor affecting external heat gain in buildings. Depending on the time of year, the building type and the orientation of the openings in the building this gain can promote or detract from the thermal comfort of the interior environment. In the case of the horizontal openings related to toplighting concepts this solar gain, especially during the Summer, tends to detract from thermal comfort unless measures are taken to control its penetration at these times. The measures which are effective in controlling solar gain are numerous and will be addressed in Chapter 5. The important principle to note at this point is that any measures taken to reduce solar gain will likewise reduce the transmission of the diffuse component as well.

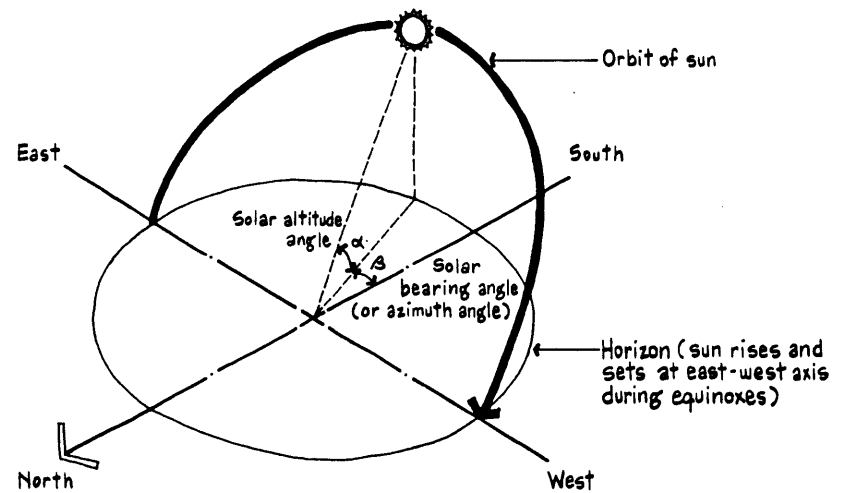

Fig. 20. Diagram of sun path across the sky.

PARTLY CLOUDY SKY CONDITION

The partly cloudy sky condition is the most widely ranging and rapidly changing in daylight intensity of all sky conditions. This sky condition is made up of direct beam and/ or diffuse components depending on the visibility of the sun disk in relation to the observer. The United States Weather Service defines this sky condition as one in which four to seven of ten parts of the sky are clouded. Depending upon the degree of cloudiness, this sky condition can favor toplighting and floor lighting schemes over side lighting.

OVERCAST SKY CONDITION

The overcast sky condition, defined by the United States Weather Service as one in which more than nine of ten parts of the sky are clouded, has the most uniform and slowest changing daylight intensity of the various sky conditions. The overcast sky condition consists purely of the diffuse component and is typically considered the minimum daylighting condition that will be experienced in the design of buildings. In contrast, however the diffuse component of an overcast sky is approximately three times brighter at the zenith than at the horizon and consequently is relatively brighter than the diffuse component of either of the other two sky conditions on the horizontal plane. The graph in Fig.21 gives an idea of the relative magnitude of this increased brightness. It is this property of the overcast sky

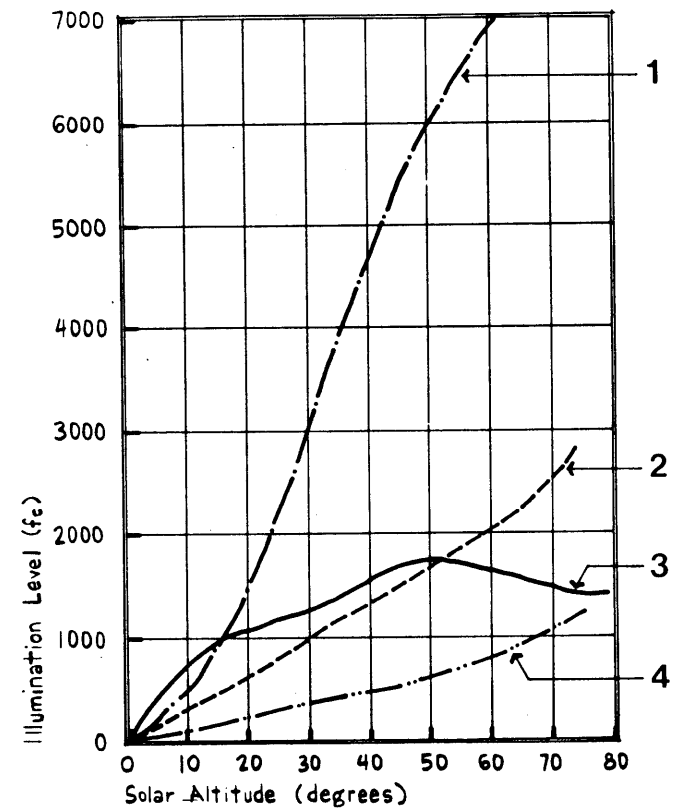

Fig. 21. Graph of average illuminance (in fc) for clear and overcast sky conditions with respect to solar angles. Key: 1. direct sun on horizontal surface, 2. overcast sky on horizontal surface, 3. clear sky on vertical surface, 4. overcast sky on vertical surface.

which makes toplighting and floor lighting the superior daylighting concepts in climates which are predominantly overcast such as England, Europe and various parts of the United States.

The selection of the appropriate daylighting concept in the design of a building is closely tied to the prevailing sky conditions which occur in that particular region. The types and frequency of these various sky conditions are largely dependent on regional climatic patterns. As difficult as specific weather conditions are to forecast on account of their high degree of variability, probabilities of occurrence of the various sky conditions can be plotted based on long term historical weather data. The Maps of the continental United States adjoining this text show the probability of occurrence of various sky conditions by location as high (more than 180 days); medium (180 to 100 days); or low (less than 100 days). The specific daylighting approach selected should take into consideration the probability of the various sky conditions and their inherent properties. There are two components involved in the arrival of daylight at the intended task in a building: the first involves the properties of the source or in this case the sky condition and the second involves the properties of the receiver or in this case the building fenestration and form.

DAYLIGHT REFLECTION

There are two optical principles which relate to the

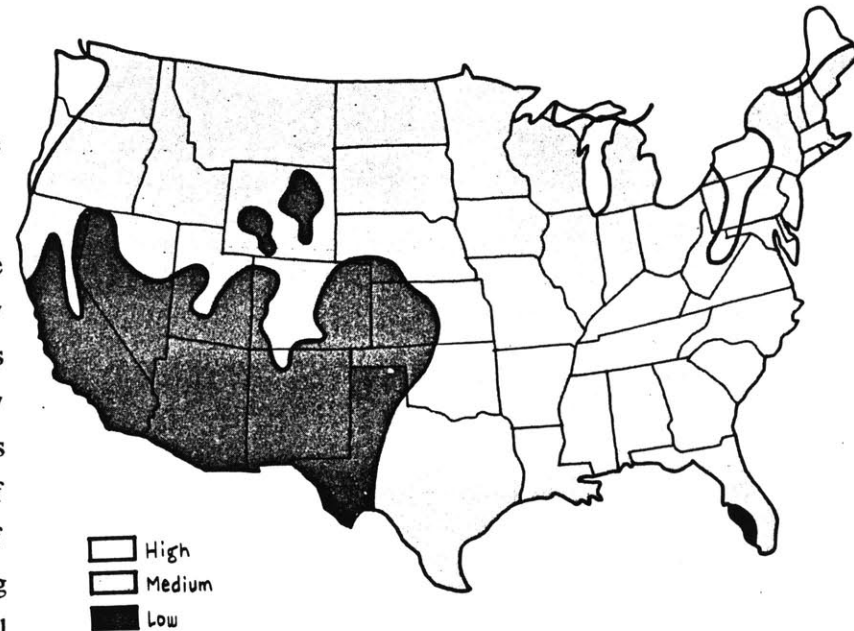

Fig. 22. Map of the United States showing yearly occurrences of cloudy sky condition.

properties of the building fenestration on both the interior and exterior as well as the roof and elevations. The first optical principle which affects the travel of the incident daylight on the building fenestration is that of reflection, as either diffuse or specular, off of the immediate profiles of the window and skylight openings. In most cases it is diffuse reflection as specular reflection tends to cause serious glare problems in this application. When these profiles become substantial, the effect of this first reflection can have a significant impact on the initial distribution of daylight. The most common example of the employment of this principle is in the large extended window sills and light shelves used in vertical applications to reflect light up onto the ceiling of the room. In terms of the skylight, the initial reflection of daylight, off of surrounding roof surfaces in the case of the monitor configuration or off of shading louvers in the open well configuration, are both common applications of this principle. In terms of the translucent floor system per se, this principle becomes more of a consideration on the interior of the building. However, it is important in optimizing the performance of the initial skylight opening.

DAYLIGHT TRANSMISSION

The second and most common principle regarding the building fenestration is the transmission of daylight or the ratio of incident to transmitted light through a given

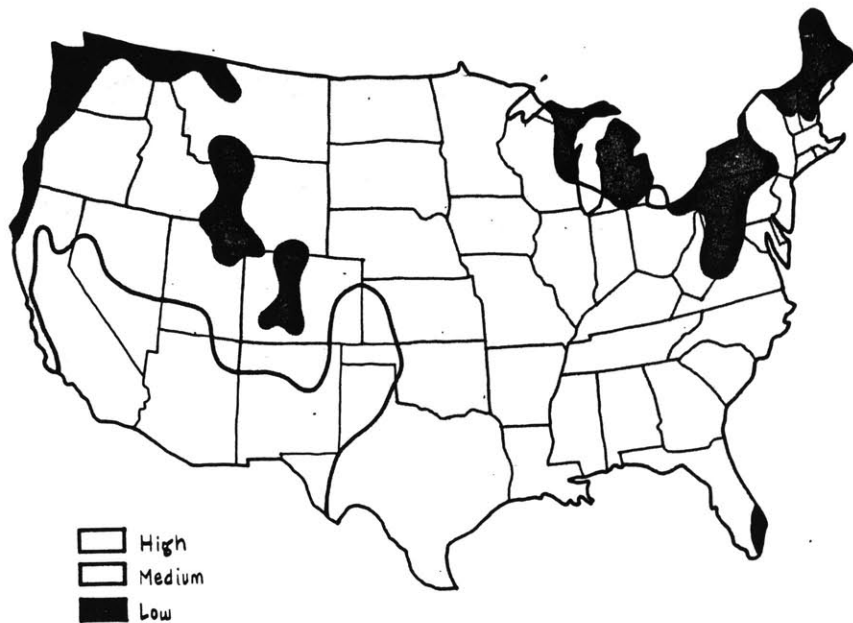

Fig. 23. Map of the United States showing yearly occurrences of clear sky condition.

translucent or transparent material. The light which is not transmitted through a material is either reflected or absorbed. Of the light which is transmitted through the translucent material, there are two distinct types: diffuse and specular. Table 1 & 2 gives the transmission coefficients for various glazing materials as well as those for typical floor light lenses.

In addition to the transmission of light through these various translucent materials, a certain amount of light is absorbed by the structure which is required to support, either vertically or horizontally, the translucent material itself. This structural transmission loss is typically ten to twenty percent in most window and skylight systems, but it becomes much more significant in the consideration of floor lights and translucent floor systems. This increased light transmission loss arises directly from the increased dead and live loads which floor surfaces are subject to in comparison to the roof or wall and consequently the larger sections and ratios of structure. When attempting to optimize the transmission of daylight through the floor light system, the tendency is to utilize the maximum structural capacity of the glass itself in place of additional opaque components such as steel or concrete.

INTERIOR REFLECTANCE

Once the daylight has been transmitted through the exterior fenestration as either diffuse or specular (direct beam) light,

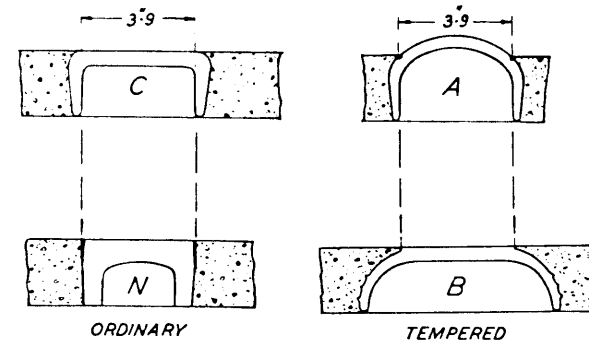

TYPE	EFFECTIVE APERTURE	LATERAL SURFACES	TRANSMISSION FACTOR
A	3.9 in. diameter	Untreated	0.40
		Painted white	0.51
		Silvered	0.70
B	3.9 in. diameter	Untreated	0.64
		Silvered	0.76
N	3.9 in. diameter	Untreated	0.46
		Painted white	0.58
		Silvered	0.58
C	3.9 in. square	Untreated	0.55

Table 1. Light transmission values of several glass lens types.

Type	Transmittance (%)
Clear plate glass, tempered glass, wired glass, clear plastic*	80-90
Patterned glass, frosted glass	70-75
Heat-absorbing glass	65-85
Clear double-pane glass	65-80
Glass block	40-75
Tinted glass, bronze	50
Tinted glass, gray	40

Table 2. Light transmission values of typical glazing materials.

another optical principle of daylight begins to influence the travel and distribution of daylight within the building interior. This is the principle of reflectance of light off interior floor, wall and ceiling surfaces. Like transmitted light, reflected light can be either diffuse or specular in nature. The degree and type of reflectance of interior surfaces is directly related to their orientation to the source, color, shape and texture. It is beyond the scope of this thesis to develop the concept of room cavity ratios for daylighting purposes, but it will suffice to say that this ratio is a unique characteristic of each specific room derived from a function of the size of the room, the location of the daylight source and the combined reflectances of its surrounding surfaces. This concept, as it relates to surface reflectances and orientations, determines the diminishing of daylight in its propagation through successive floor lights.

DAYLIGHT REFRACTION

The final optical principle which is of interest in the understanding of the travel of daylight into and through a building is the principle of refraction. Refraction is simply the bending or scattering of light which occurs in the transmission between two different mediums, specifically glass and air. Both translucent and transparent materials refract, that is they have the capacity to change the initial direction of light. However, the degree of refraction which takes place in transparent materials when the surface is roughened

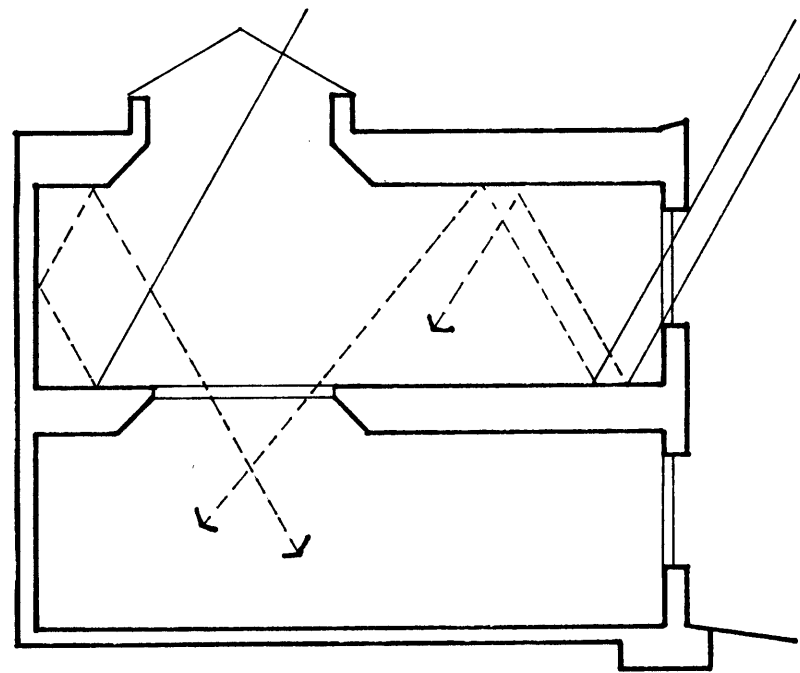

Fig. 24. Schematic building section diagramming the travel of reflected daylight into and through the interior.

is relatively slight and on a much smaller scale than other translucent materials. In fact, the degree of light or image refraction of a material is the basis on which the terms transparent and translucent are defined. The capacity to refract and change the direction of light makes these materials useful in spreading daylight to various portions of a room which would not normally see as much of the sky.

There are two distinct types of refracting materials in the discussion of daylighting. The first type is diffuse refraction and is similar to all of the other types of diffusion which have been mentioned. In this case, all of the diffusion takes place in the material and is made up of many compounded refractions occurring within the material, resulting in a fairly uniform distribution of emitted light. Some examples of this type of material are cathedral glasses, Kalwall and opal glasses. The glazing materials which exhibit this type of refraction are typically used to obscure views in window and borrowed lights and diffuse direct beam sunlight in skylight applications. Although this type of refraction is utilized in some floor light applications, such as library stack room systems, it does not distribute the diffused light in any optimal pattern to overcome the light distribution deficiencies of the particular space. These lenses rely on random uniform diffusion of the light and although they are an improvement over transparent lenses, they do not employ the more effective nature of specular refraction.

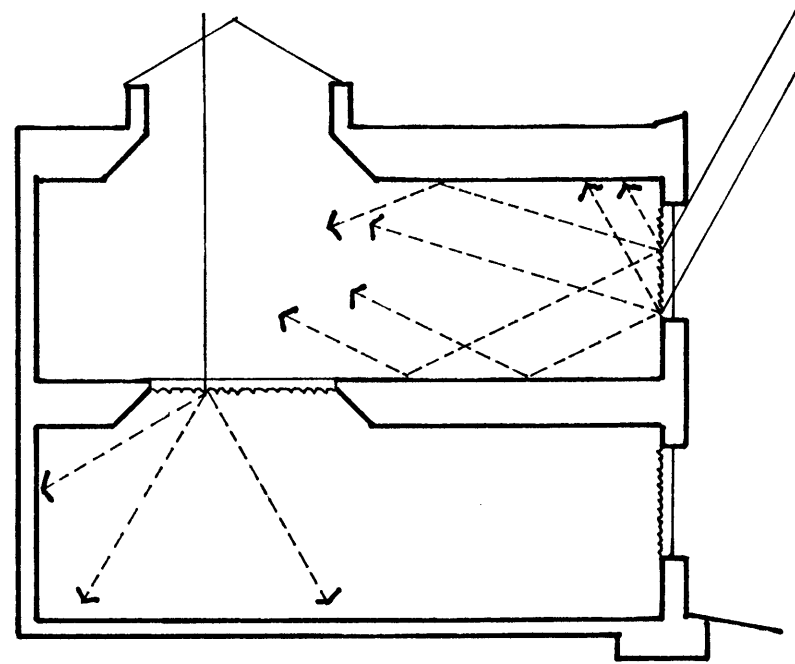

Fig. 25. Schematic building section diagramming the effect of light refracting materials in window and floor openings.

The second type of light refraction is specular refraction characterized by prismatic glasses or lenses. Unlike diffuse refraction, this type of refraction involves only one distinct redirection of the light. Based on the relative angles of the incident and exitent surfaces of the lens, this type of refraction can diffuse, focus or leave unchanged the initial image of the light. Materials with this property have the ability to distribute daylight in an optimal pattern in order to overcome the daylight distribution deficiencies of a particular room shape. Although some patterned plate glasses have been produced with this feature, most of the research and production in this area has been devoted to pressed glass blocks and lenses for both wall and floor paver applications. The extra thickness which is required to achieve this refraction probably accounts for the concentration of these properties in this specific building material. Most of the contemporary floor lenses employ specular refraction for light distribution purposes by providing a prismatic pattern pressed into the underside of the lens.

These many properties of the source of daylight and the receiver or building form a basis for the understanding of the travel, quality and quantity of daylight within a theoretical context. In order to see the combined effect of each of these properties in a building setting, a physical modeling program must be undertaken. As the physical modeling program is discussed in this thesis, most of these

theoretical properties will be evaluated as to their contribution to the design and engineering of translucent floor technology.

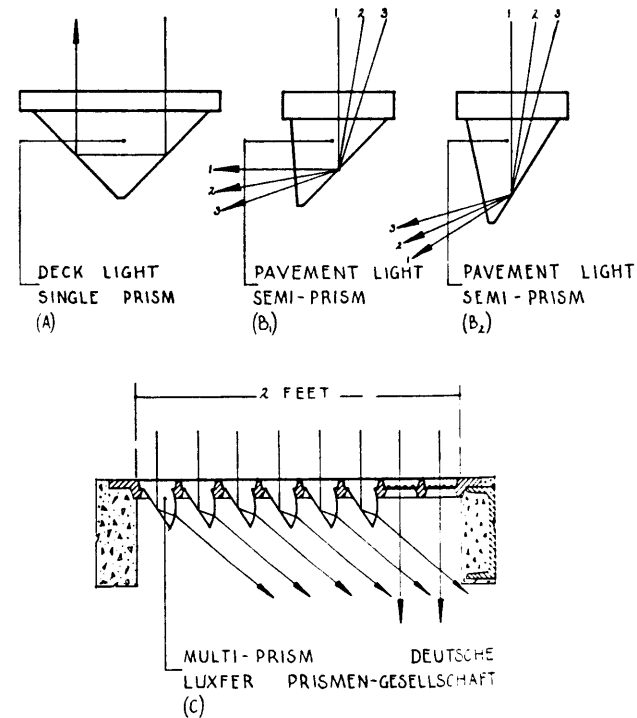

Fig. 26. Several prismatic lens profiles employing daylight refraction.

Chapter 3

MODELING DAYLIGHT PROPERTIES OF TRANSLUCENT FLOOR SYSTEMS

MODELING PROGRAM

In order to begin to apply the floor light to specific architectural designs, it is first necessary to model the quality and quantity of penetrating daylight as a function of various building and floor light characteristics. The building and floor light characteristics which are important to include in this modeling study are the following:

1. The aspect ratio or well index of the skylight and floor light combinations.
2. The room cavity ratio of spaces in which the sky and floor light are placed.
3. The wall, ceiling and floor reflectances of the rooms in which the sky and floor lights are placed.
4. The configuration and orientation of sky and floor light construction.
5. The transmission properties of the floor light construction.



Fig. 27. Interior of daylight model with 6'-0" x 6'-0" floor light.

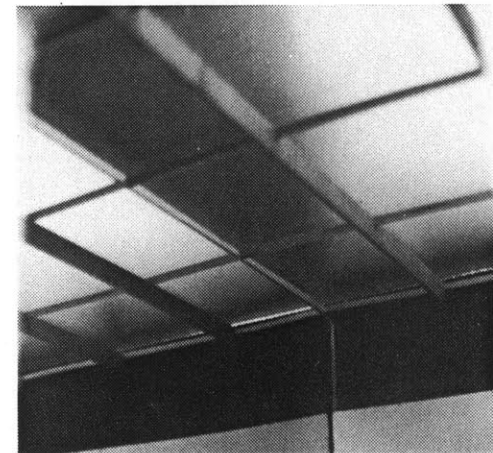

Fig. 28. Interior of daylight model with steel and glass floor light.

6. The refraction and diffusion properties of the floor light construction.

7. The light distribution characteristics of various floor light and light shelf configurations.

8. The reflectance and light distribution characteristics of floor and skylight well profile.

MODELING METHODS

There are several methods of daylight modeling available for the purpose of determining the effects of these various factors. The construction of a physical model is probably the oldest and most versatile method for simulating the quality and quantity of the penetrating daylight within a building. A somewhat more theoretical and limited method of daylight modeling is the two dimensional graphical construction and associated daylighting formulae. The Lumen method and the point method are two examples of this type of graphical construction and calculation method. Although this method is effective in quantifying the daylight distribution of relatively simple daylighting devices, it is not possible to assess increasingly complicated features such as diffusion, refraction and light shelves as well as the more qualitative aspects relating to these characteristics. During the past ten to fifteen years with the growth and development of computer technology, a number of daylight modeling programs have been developed through a mechanization of the graphical

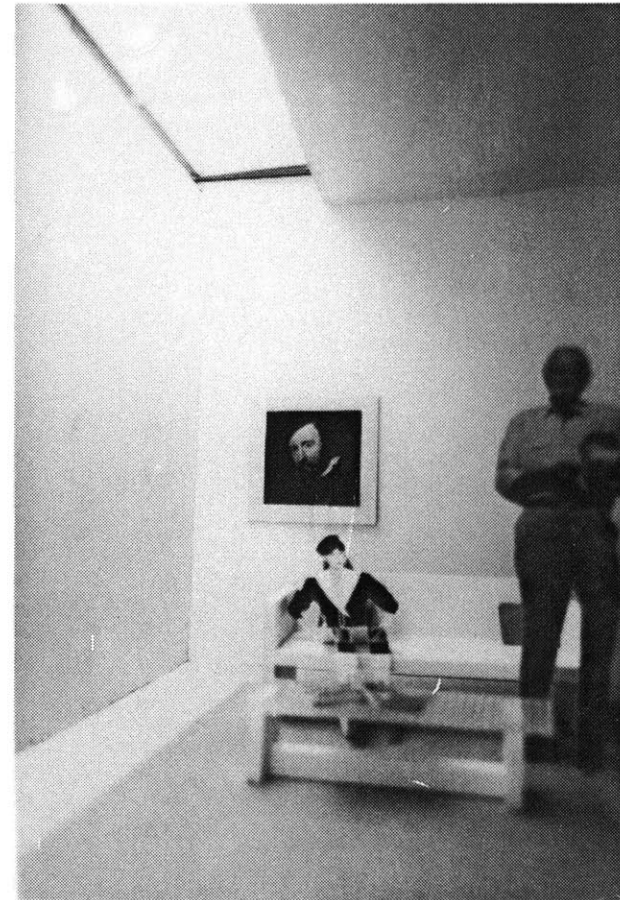

Fig. 29. Physical light model used in analysis of rowhouse.

construction method, which are effective design tools for quantifying interior daylight levels resulting from windows and skylights. Unfortunately, these programs, like the graphical construction modeling method, are limited in their capacity to model diffusion and refraction properties of various glazing materials as well as the more qualitative aspects of interior daylight patterns. The physical daylight model is the only method which is capable of simulating the refraction and diffusion characteristics of the floor light technology being modeled in this thesis. Consequently, the physical modeling method is utilized in the investigation of the light distribution properties of these various building and floor light characteristics.

MODELING PROCEDURE

The physical model employed in this daylighting simulation is constructed in such a way as to allow for the manipulation of the building and floor light characteristics outlined in the beginning of this section. Specifically, this model, constructed at a scale of 1"=1'-0", simulates a 16'-0" x 16'-0" shaft with four interchangeable floors spaced 12'-0" floor to floor. Within this light tight shaft, each of the three intervening floors and the floor lights in them can be readily varied as well as all the wall reflectances of the four wall surfaces. The base interior wall surfaces are painted flat black with a reflectance of 10% to simulate a very high room cavity ratio. In order to simulate the reduction of room cavity



Fig. 30. Physical light shaft model showing one floor light combination.

ratios, quantity or size of floor, or sky lights and room size, the base wall reflectances can be increased to matte white (80% reflectance) or a mirrored surface (100% reflectance). In other words, the addition of mirrored surfaces on the walls of the individual rooms could simulate a multifold increase of room size and size or number of floor or skylights in the room.

The size of the three intervening floor light apertures, the initial skylight, and the floor light construction are consistently varied throughout the modeling so as to steadily increase the absolute light level or daylight factor. The skylight aperture is varied from an initial 4'-0" x 4'-0" opening size proceeding to be increased to 6'-0" x 6'-0", 8'-0" x 8'-0", 12'-0" x 12'-0", and finally a full 16'-0" x 16'-0" opening. In all of the above cases the skylight is centered over the room below and maintains the same ceiling well profile. Similarly, the floor light apertures investigated are varied from an initial series of 2'-0" x 2'-0" apertures through most, but not all, of the range of various aperture combinations through: 6'-0" x 6'-0", 12'-0" x 12'-0", and finally a full 16'-0" x 16'-0" floor light. As the floor light apertures are increased, the transmission of the floor light construction is also increased towards maximum theoretical levels in order to explore the maximum effectiveness of this technology.

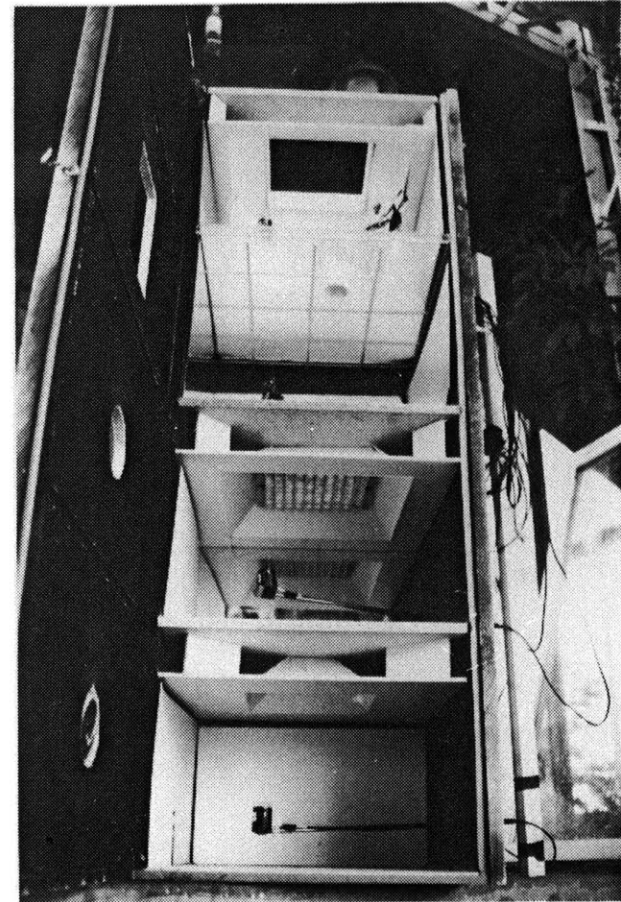

Fig. 31. Physical light shaft model showing an additional combination of floor lights.

Beyond the sky and floor light aperture combinations, a number of other more specific floor light configurations are investigated as to the quality and quantity of daylight. The first variation in configurations explores the light distribution characteristics of multiple, equally spaced, small floor lights over a single larger floor light of the same total area. It should be noted at this point that references to floor levels on the model in both the data and this description are based on proximity to the initial skylight rather than the conventional ground floor. Consequently, referenced floor levels should be thought of as the first, second, and third floor beneath the initial skylight. On the first floor of the model, the multiple floor lights are equally spaced out from the side walls and centered about the room. The multiple floor lights on the second floor are placed nearer to the corners in order to take advantage of the line of sight to the initial skylight above and the "corner effect" discussed later in the conclusion of the section.

The second building-specific variation explores the light distribution characteristics of various floor and side light or window configurations in order to bring daylight into a space below. The daylight distribution, quality and quantity is evaluated as a function of the location of a 3'-0" x 6'-0" floor light relative to the foot of a 4'-0" x 6'-0" side light or window opening. In this investigation, several other

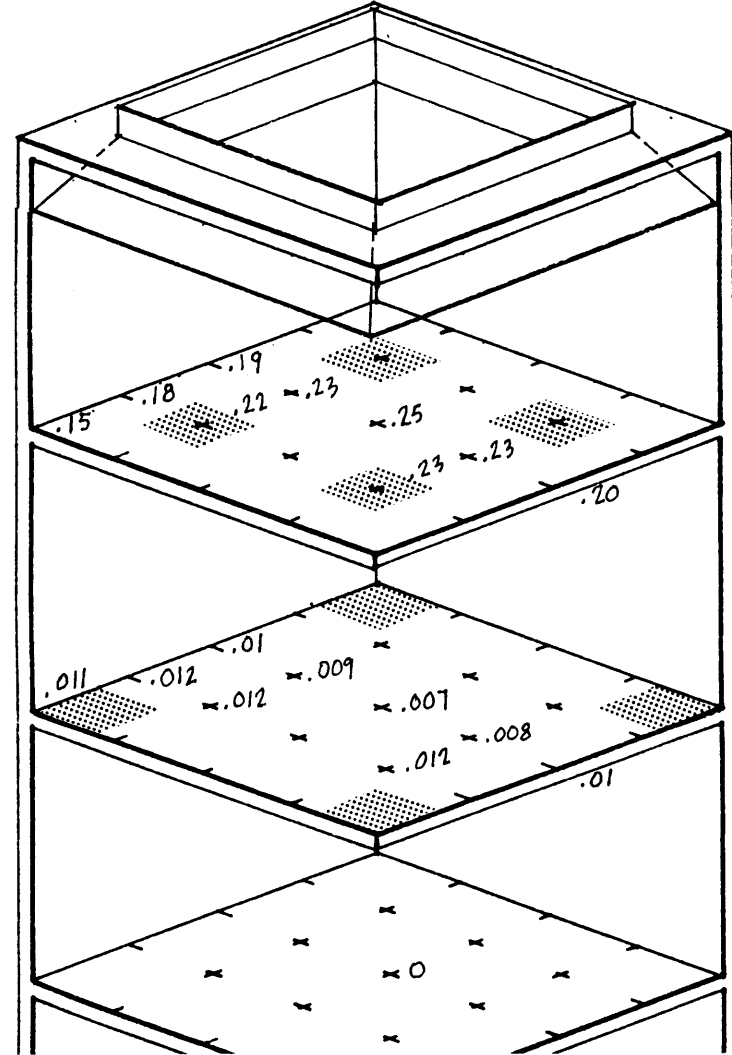

Fig. 32. Isometric diagram of daylight model showing orientation, location and resultant footcandles of multiple floor lights.

variables are introduced such as window orientation, room reflectance and light shelf profiles.

The third building specific floor light variation is in conjunction with the final chapter dealing with the exploration of several architecturally specific and integrated floor light configurations. Here the continuous, linear corridor floor light system utilized in the Freeport Middle School is further studied and the relationship of daylight distribution to type, placement and orientation of light shelves is explored. In conjunction with the development of a prototypical lowrise commercial or institutional project, a two-way continuous collinear skylight and floor light grid is modeled to explore the quantity and quality of the daylight distribution. Finally, a floor light configuration similar to the school building type is explored as an application to introduce some core lighting to the urban rowhouse. This configuration investigates the collinear and continuous floor and skylight combination placed adjacent to intervening party walls along the building.

MODELING APPARATUS

The base daylighting model itself is constructed of 1/2" particle board with fixed wall panels on three sides and a light tight access door on the fourth side allowing for manipulation of the side wall reflectances, floor light and skylight apertures. The various floor light and skylight well profiles are constructed of opaque white foam core or

illustration board and are adhered to the underside of the floor. Various types of glass are utilized in the simulation of the floor light assemblies. The 6'-0" x 6'-0" floor light is simulated by an actual sample of the Westerwald Ag. prismatic glass lens (model B 16). The reinforced concrete support structure, in this case, is simulated by a 6" x 6" Basswood grid hung beneath the lens. The transmission of this assembly approximates the 50-60% transmission range which can be expected from this type of construction. The 12'-0" x 12'-0" floor light is simulated by a piece of patterned, light diffusing glass with a transmission of 75%. The reinforced concrete support structure, in this case is simulated by a 12" x 12" x 6" deep Basswood grid laid on top creates an overall transmission of 65%. In order to simulate various types of floor light construction, the 16'-0" x 16'-0" floor lights are modeled using patterned, light diffusing glass with a transmission of 75%. In contrast to the smaller lights, the support structure simulates the much higher transmission of a structural steel support system and is modeled by a 4'-0" x 4'-0" x 10" or 3" deep Basswood grid creating an overall transmission of 70%. This value is probably the highest possible transmission that can be expected with this technology.

The daylight measurement equipment employed in these investigations utilizes a multiple channel data acquisition system, the HP 3421A Data logger package and seven

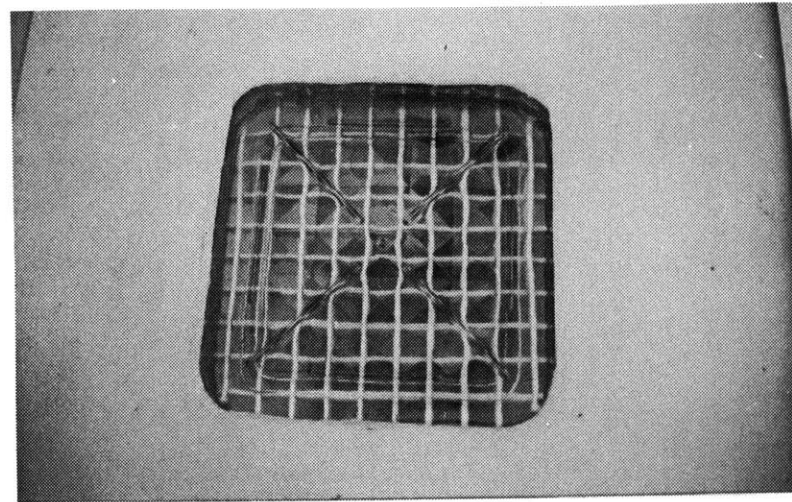

Fig. 33. Floor light model of 6'-0" x 6'-0" aperture with Basswood grid simulating reinforced concrete support structure.

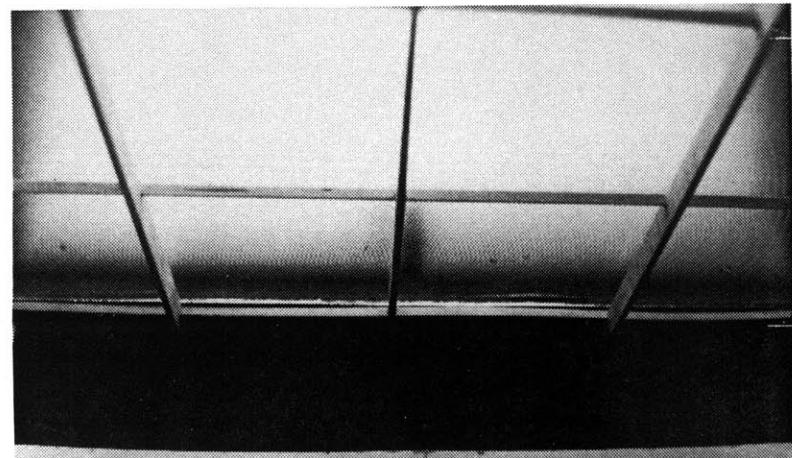

Fig. 34. Floor light models of 16'-0" x 16'-0" aperture with 4'-0" O.C. simulated structural steel support structure.

photometers with cal connectors. Four of the seven photometers are attached to a movable, four pronged instrument frame which allows the photometers to be held at the work surface and moved simultaneously from outside the model to the same known location on each of the four floors of the daylight model. The remaining three photometers are placed on top of the light model to sample the ambient daylight level between each of the interior readings. Although the data logger samples data as close to simultaneously as possible, there is still a margin of error introduced as a result of the real time difference of one to two seconds between each of the readings. The daylight levels measured in millivolts and converted to footcandles are collected in sequence on a thermal paper printer and attached to a graphic record of the specific sizes of skylight and floor light apertures, wall reflectances, and transmission for later comparison. Each pass of the data acquisition equipment represents one specific location within the model and consists of seven data points, one from each of the seven photometers. The simple movement of the photometer support frame between passes allows for the near simultaneous collection of up to four data points at various points within the model.

EXPERIMENTAL PROCEDURE

The experimental procedure employed during the physical modeling was founded in the following steps:



Fig. 35. Physical light modeling apparatus including: model, data acquisition equipment and multiple photometer armature.

1. Construct a light tight scale model of the proposed floor and skylight configuration.
2. Model all wall, floor, and ceiling reflectances, apertures, well profiles, floor light construction and transmission true to scale and quality of full size application.
3. Place the model in actual daylight conditions as far as possible from surrounding buildings and obstructions of the horizon.
4. Position light photometers at same known point and work plane (30" off of floor) on two to four floor levels within the model.
5. Record interior and ambient daylight levels in foot candles in a manner as close to simultaneously as possible. Also record time of day and sky condition.
6. In order to calculate the daylight factor for each data point within the model, take the ratio of the interior daylight level over the ambient daylight level in footcandles. The daylight factor for interior locations is the only type of daylight measurement which is comparable between two different model configurations given the same sky condition.
7. Change some variable in the physical model such as wall reflectance, room ratio, floor light transmission or well index.

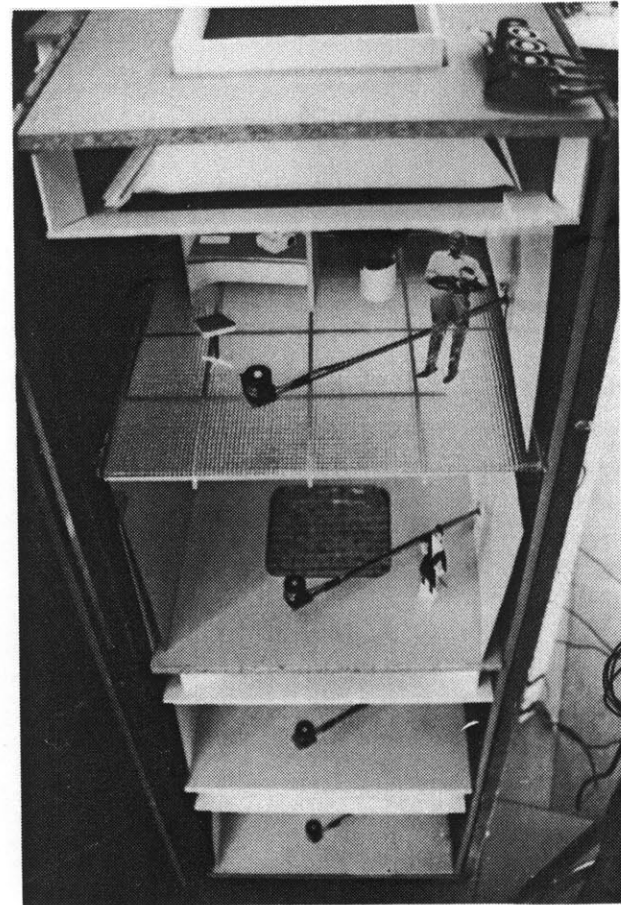

Fig. 36. Physical light shaft model showing multiple floor lights, ambient photometer and multiple meter armature.

8. Repeat procedure from step 4 and compare daylight factor for same locations noting relative change.

9. Repeat step 8 until established standard for daylight factor has been achieved or approached as nearly as possible.

All of the physical daylight model testing was done under ambient daylight conditions. It was pointed out in chapter 2 on the nature of daylight, that the light level from the sky is constantly changing. With this in mind, inasmuch as was possible, most of the tests were conducted under overcast skies. The reasons for this qualification are:

1. That this sky condition offers a zenith which is three times as bright as the horizon, tending to favor this toplighting application.

2. The use of the daylight factor as a means of comparison was developed to be applied only under uniformly overcast sky conditions. Nevertheless, some of the testing was conducted under partly cloudy and clear sky conditions as a comparison to the overcast sky condition. In these cases the ambient photometers were shaded from the direct sun in order to measure only the diffuse sky component. The daylight factors which are derived from this shaded ambient photometer data are typically lower than those derived from overcast sky conditions. Consequently, in interpreting the

absolute daylight factors from models tested with shaded photometers it should be noted that these factors would be higher in overcast daylight.

DAYLIGHT STANDARD

In order to guide the evaluation and modeling procedure, it is first necessary to establish criterion for the quality and quantity of daylight resulting from the various combinations of floor lights. In terms of the quality of the daylight, it is difficult to make generalizations without knowing the specific application. However, there are two qualities which are generally essential in any application. The first quality is that the daylight be free of direct or contrast glare conditions. The best way to judge this quality in daylight is by placing a scale figure in the model nearest the possible glare condition and attempting to read texture or lettering on the figure. If this can be done, then there is probably not a serious glare problem. The second quality of daylight which is generally applicable for all purposes, is the evenness of distribution. A rule of thumb in judging this quality is that daylight factors figured at various points throughout a room should be within a factor of two of each other. If the daylight factors for any of these points exceeds this factor, then that portion of the room would probably be perceived as being dark relative to the rest of the room.

It is equally difficult to make generalizations regarding the quantitative criterion for appropriate interior daylight factors as these are a function of average ambient illuminance, task and time of year. These values will tend to vary greatly depending on building location, and scheduling. A school building, for instance, is typically used for only nine months of the year and therefore this period is weighted in selecting the standard ambient sky illuminance. Whereas an office building, used year round, tends to include the summer months and consequently is evaluated based on a higher standard ambient sky illuminance value.

In order to make the results of this modeling as generally applicable as possible, a standard ambient sky illuminance in the range of 700- 900 foot candles was selected as the criterion for judging quantitative daylight factors. As indicated in Table. 3, this is the range of overcast sky illuminance which can be expected 85% of the time between 8:00 am and 4:00 pm at the respective range of latitudes across the United States.⁽¹³⁾ Given this range for the standard sky illuminance, the suggested minimum daylight factors for various types of spaces are given in Table. 4.⁽¹⁴⁾ These quantitative criteria now establish a standard upon which the results of this modeling can be evaluated.

MODELING RESULTS

The isometric diagram and table in fig. 37 shows a typical model variation and the resultant daylight factors used to

North latitude (degrees)	Illumination level (fc)	Example locations
46	700	Montréal; Minneapolis; Portland, Oreg.
42	750	New York; Chicago; Eureka, Calif.
38	800	Washington, D.C.; Denver; San Francisco
34	850	Clemson, S.C.; Albuquerque; Los Angeles
30	900	New Orleans; San Antonio; Ensenada, Mex.

Table 3. Average external illumination levels (in fc) from overcast sky conditions, available about 85% of the day from 8am to 4pm for various locations in the United States.

Type of space	DF (%)	A_w/A_f (%)
Art studios, altars (if strong emphasis is desired)	4-6	20-30
Laboratories (e.g., work benches)	3	15
General offices, banks (e.g., typing, accounting), classrooms, gymnasiums, swimming pools	2	10
Lobbies, lounges, living rooms	1	5
Corridors, bedrooms	0.5	2.5

Table 4. Suggested minimum daylight factors for various types of spaces.

FLOOR LIGHT PHYSICAL MODELING TEST 19

SKY CONDITION: overcast 2000-2500 fc
 TIME OF DAY: 3:05 PM

WALL N E S W
 ORIENTATION
 SKYLIGHT SIZE= 12'-0"x 12'-0" T=65%
 WALL
 REFLECT. 80% 80% 80% 80%
 1ST FLOOR LIGHT SIZE= 12'-0"x 12'-0" T=70%
 WALL
 REFLECT. 80% 80% 80% 80%
 2ND FLOOR LIGHT SIZE= 6'-0"x 6'-0" T=50%
 WALL
 REFLECT. 10% 10% 10% 10%
 3RD FLOOR LIGHT SIZE= 2'-0"x 2'-0" T=75%
 WALL
 REFLECT. - - - -
 FLOOR REFLECTANCE= 45%
 (Typical all floors)

	1ST	2ND	3RD	4TH
CEILING				
REFLECT.=	30%	50%	70%	75%
CEILING				
HEIGHT=	8'-6"	11'-0"	11'-0"	8'-6"

REMARKS: Increased skylight aperture. Decreased floor light apertures on 1st, 2nd and 3rd floors. Wall reflectances similar to test 17 with decreased room cavity ratios on 1st and 2nd floor. Good daylighting levels on 1st and 2nd floor with insufficient levels on the 3rd and 4th floors.

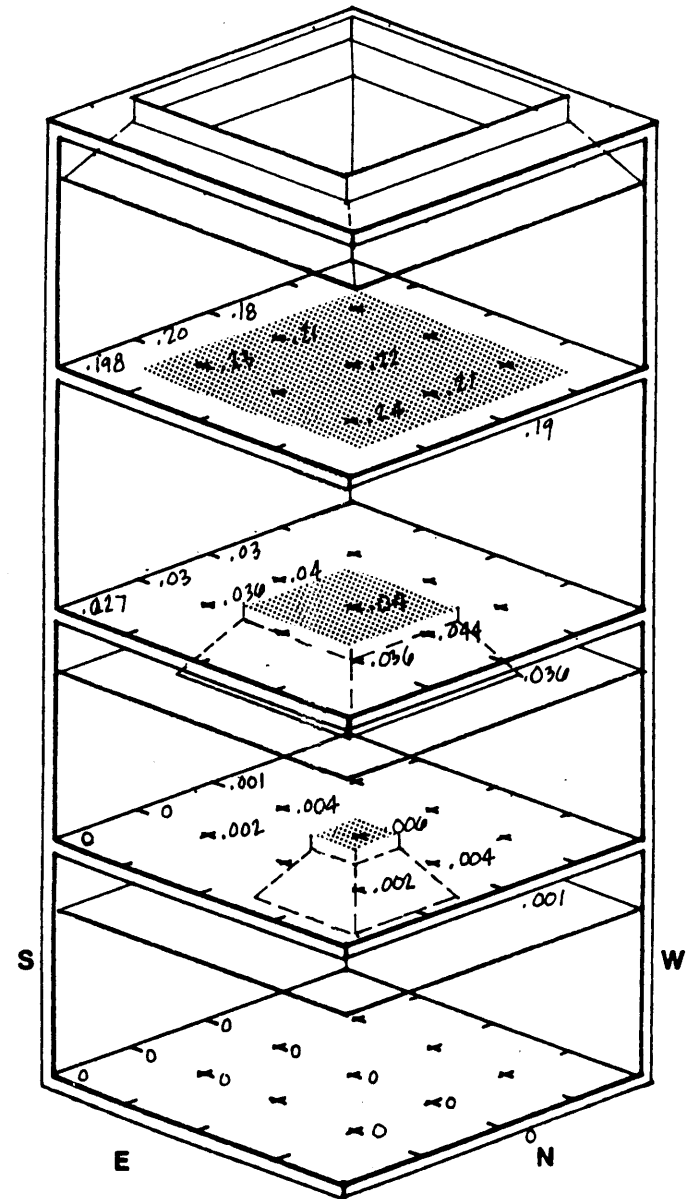

Fig. 37. A typical model variation from Appendix A.

compare model variations. In Appendix A, the sequence of daylight model isometric diagrams, accompanying tables and remarks represents the range of and results from the testing. The measurements were taken during the daylight hours as indicated in each test beginning on 3-6-85 up until 3-23-85. In each of the tables accompanying the diagrams the letter "T" is an abbreviation for transmission and "REFLECT." is an abbreviation for reflectance. The North and East walls have been removed in the isometric drawing in order to diagram the interior floor lights and list the specific daylight factors resulting from each combination. Each of the specific test combinations may be interpreted individually given the various parameters in the table or when taken as a group can be used to derive general relationships between aspect ratio or well index, wall reflectance, room cavity ratio, floor light and skylight transmission, aperture size and resulting daylight factors.

THE RELATIONSHIP OF DAYLIGHT FACTOR TO WALL REFLECTANCE AND ROOM CAVITY RATIO

There is a direct relationship between the daylight factor on various levels of a series of collinear, stacked skylight and floor lights and the relative size or cavity and wall reflectance of the rooms which contain them. The relationship follows that as either the room cavity ratio is decreased or the surrounding wall reflectances are increased, the resulting

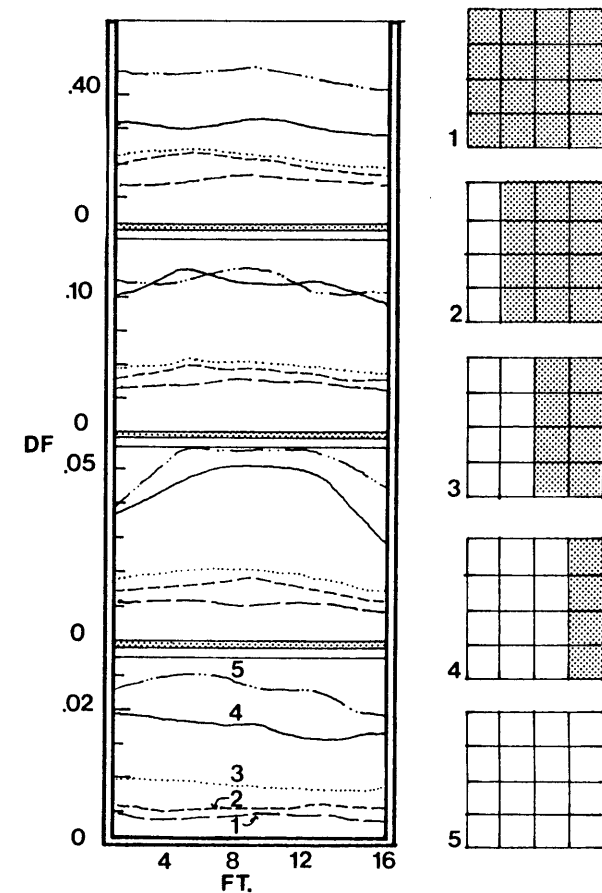

Fig. 38. Section of physical daylight model similar to Test 28-29 showing graphs of daylight factor on each level with respect to location in feet. Shaded grids on right denote degree of wall reflectance (white = 80% and black = 10%) and are keyed to graphs by number.

daylight factors will be increased throughout the room and for succeeding floors down from the initial skylight.

Because of the type of model utilized for testing, in that variations in wall reflectance were used to simulate various room ratios, it is difficult to separate the individual effects of these two variables. However, it is possible to establish from existing literature that as the room cavity ratio is decreased, the reflectances of the surrounding wall surfaces become increasingly effective. In other words, it is hard to distinguish the effects resulting from a small room painted a dark color and a large room painted a light color. However, it is possible to say that a light color or high wall reflectance will be more effective in a small room.

The diagram in fig. 38 and the graph in fig. 39 are an attempt to quantify this relationship based on data gathered during testing. This graph may be used to predict resultant daylight factors, in the immediate vicinity of the floor light, for rooms containing a stacked, collinear floor light system with a transmission of 70% on the basis of average wall reflectance.

THE RELATIONSHIP OF DAYLIGHT FACTOR TO LIGHT TRANSMISSION OF FLOOR LIGHT

There is a direct relationship between the light transmission of the floor light system and the resulting daylight factors in the adjacent or surrounding rooms. The relationship is

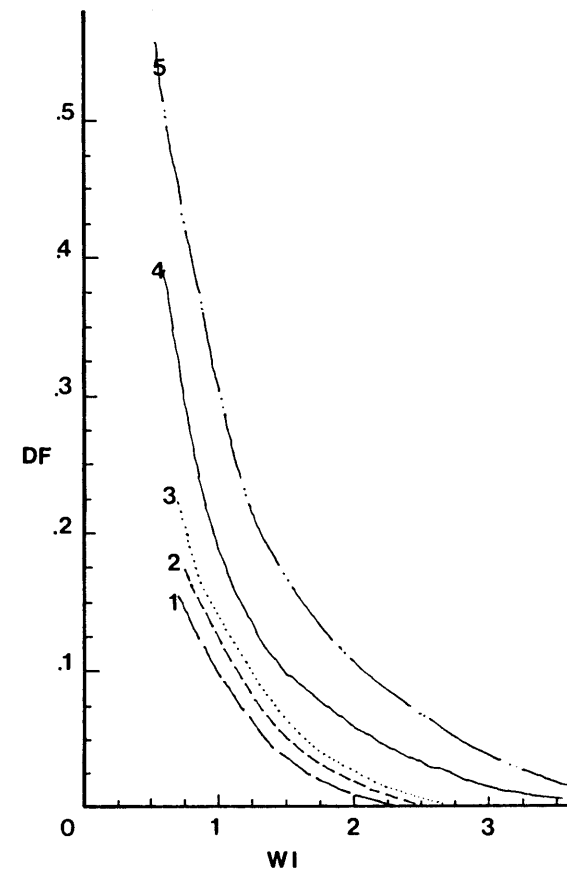

Fig. 39. Graph of average daylight factors (DF) from section of physical model (fig. 38) of the varied wall reflectances as a function of well index (WI). Numbers on graphs are keyed to earlier shaded grids.

such that as the transmission of the floor light assembly is increased, either by reducing the area of structure or increasing the transmission of the lens itself, the daylight factors in the adjacent or surrounding rooms will likewise increase.

The graph in figure 40 is a result of some of the data gathered during testing. This graph may be used to predict the resultant daylight factors in rooms containing floorlights of various transmission values.

THE RELATIONSHIP OF DAYLIGHT FACTOR TO APERTURE OF FLOOR LIGHT AND SKYLIGHT

The relationship of floor light and skylight aperture to daylight factor, in effect, expresses the same principle as the relationship of well index or aspect ratio to the latter. This is true in that aperture size is a factor in the calculation of either of the other two. For this reason a relationship need only be established to one factor and the others can be simply determined by the formula in which they are related. The characteristic which is most applicable and inclusive is the factor of well index, which considers aperture size, well height, and simple rectilinear well configuration in the equation:

$$\text{well index(WI)} = (.5H) \left(\frac{W + L}{W \times L} \right)$$

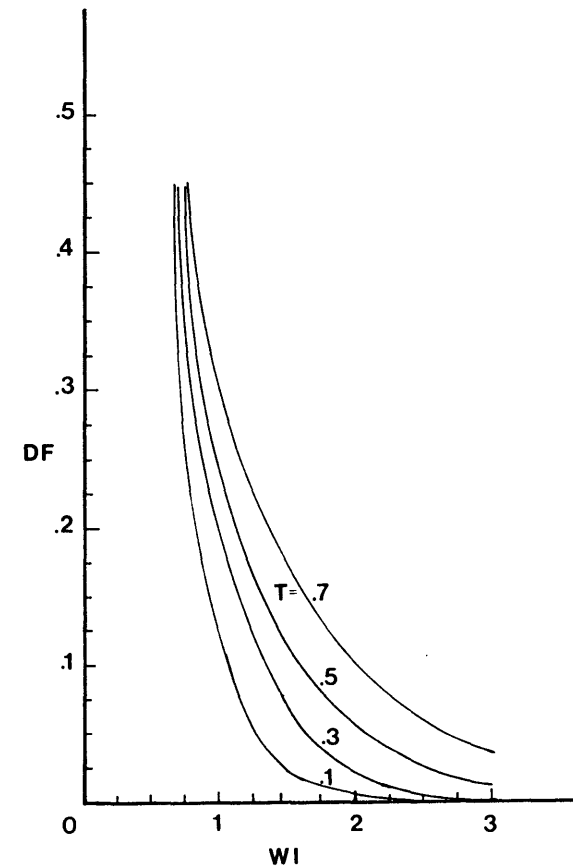

Fig. 40. Graph of daylight factor (DF) vs. well index (WI) for different floor light transmission values (T) from 70% to 10%.

Where: H= well height
W= well width
L= well length

The graph in fig. 41 depicts the relationship of the well index to the resulting daylight factors, given an average wall reflectance of 80% and a floor light transmission of 70%. This graph would tend to move down and to the left as wall reflectance decreases, room cavity ratio increases or floor or skylight transmission decreases, as shown in the earlier graphs.

THE CORNER OR WALL EFFECT

There is a direct relationship between the proximity of the floor and skylight system to surrounding wall planes and corners and the resulting daylight factor below the floor light. As the edge of the floor light is moved nearer to surrounding walls and then towards an inside corner, the daylight factor in the room below is increased. This relationship results from the configuration of the daylight source or skylight, the wall plane and the floor light, in effect funneling the daylight to the room below. It should be noted that this relationship is effective until the floor light actually reaches the corner, at which point the effect seems to be reversed. This may be the result of the increasing occlusion of the source by the surrounding walls which in the corner finally overcomes the benefits of funneling.

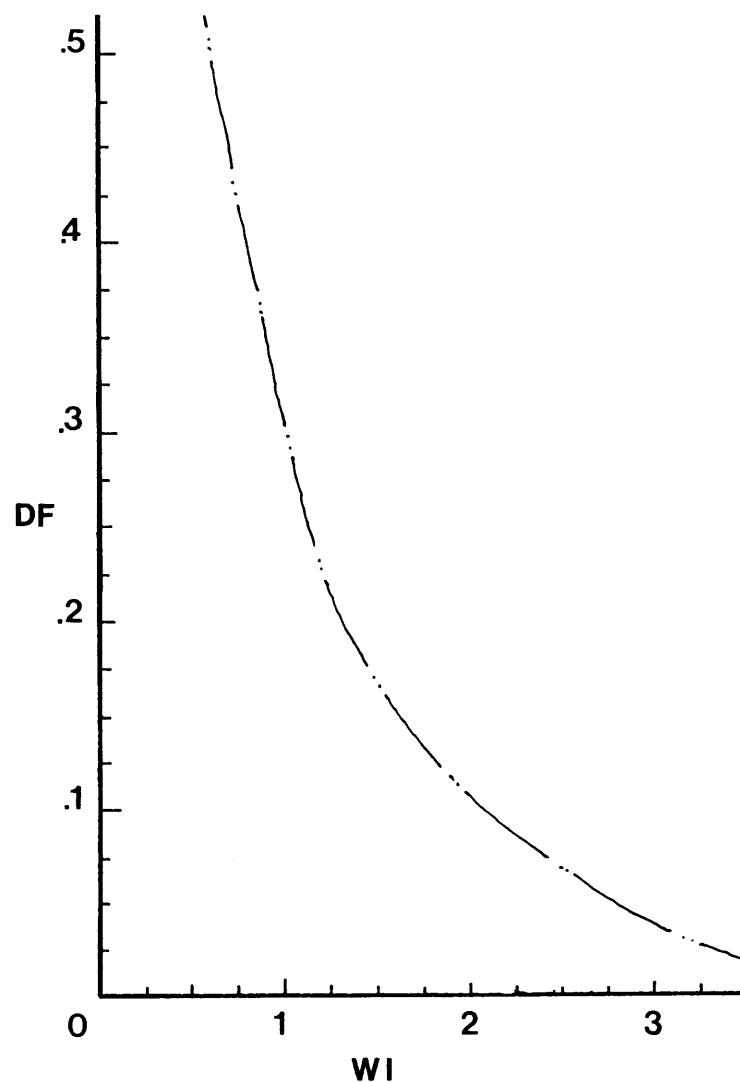

Fig. 41. Graph of daylight factor (DF) vs. well index (WI) given an average wall reflectance of 80% and floor light transmission of 70%.

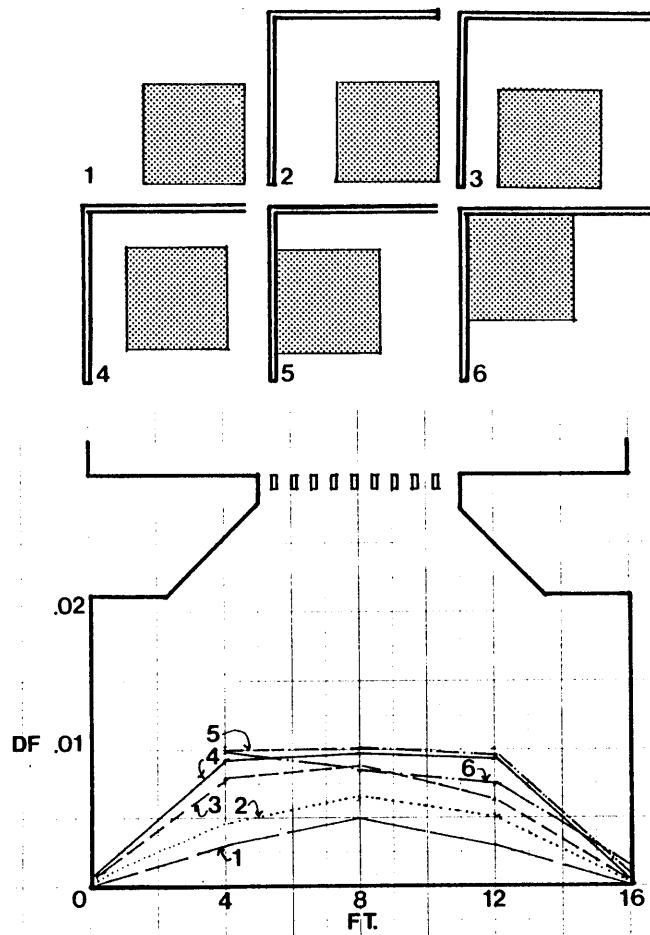

Fig. 42. Graph of location in cross section of modeled room (FT.) (scale: 3/16"=1'-0") vs. daylight factor for six positions of a 6'-0" x 6'-0" floorlight and a 6'-0" x 6'-0" skylight in the room above with respect to perimeter walls. KEY: same as fig. 43.

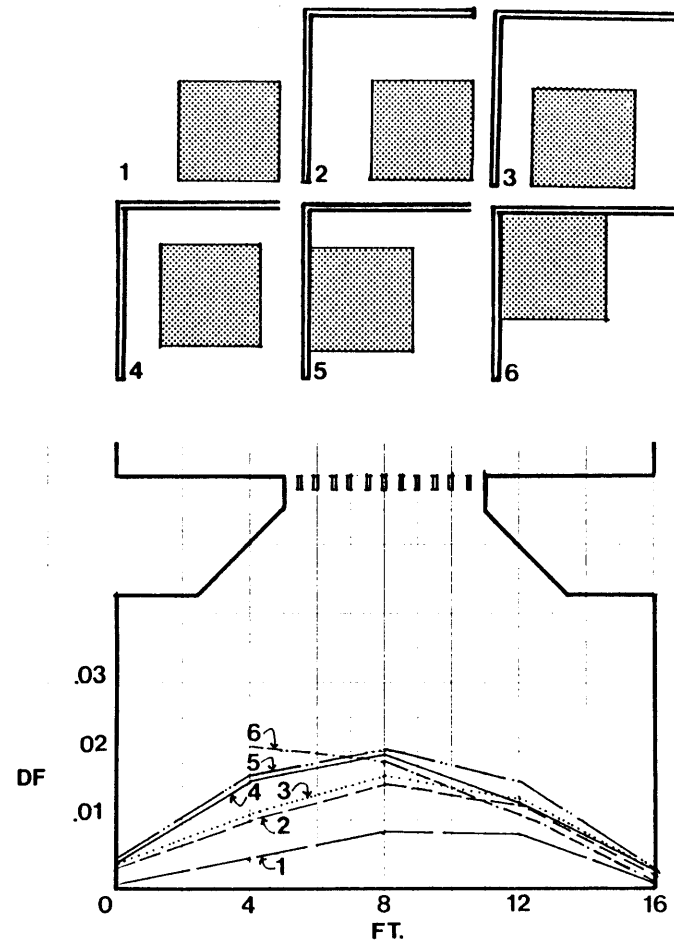

Fig. 43. Graph of location in cross section of modeled room (FT.) (scale: 3/16"=1'-0") vs. daylight factor for six positions of a 6'-0" x 6'-0" floorlight and a 8'-0" x 8'-0" skylight in the room above with respect to perimeter walls. KEY: 1. middle of room 2. 4'-0" from both walls 3. located 2'-0" and 4'-0" respectively from walls 4. located 2'-0" and 2'-0" respectively from walls 5. abutt one wall and 2'-0" from other wall 6. abutt both walls in corner.

LIGHT SHELF PROFILES AND FINISHES

When it is necessary to place walls adjacent to floor lights in order to achieve "funneling" or separation, the placement, profile and finish of light shelves above these walls can improve daylight distribution in the adjacent rooms. This relationship proves important in architectural applications in which— like the Freeport Middle School— there is an attempt to provide uniform bilateral lighting in a traditional double loaded corridor organization.

The light shelf profiles which prove most effective are those with a high surface reflectance and a profile which is splayed in the direction of the receiving room. The daylight factor in the receiving room increases as: (3) the light shelf is added, (4) increases in reflectance, and (5) is splayed toward the receiving room. It should be noted that although the light shelf is effective at passing daylight deeper into the receiving room, the elimination of the intervening wall, if possible, provides the highest daylight factor at that point in the overall building plan. Of course, it is no longer a separate room at this point.

FLOOR AND SIDE LIGHT COMBINATIONS

The skylight is the most effective, but not the only method of introducing the daylight source to a floor light. The windows or side lights along the perimeter of a building can also be used in conjunction with a floor light in order to allow the penetration of daylight deeper in to the building

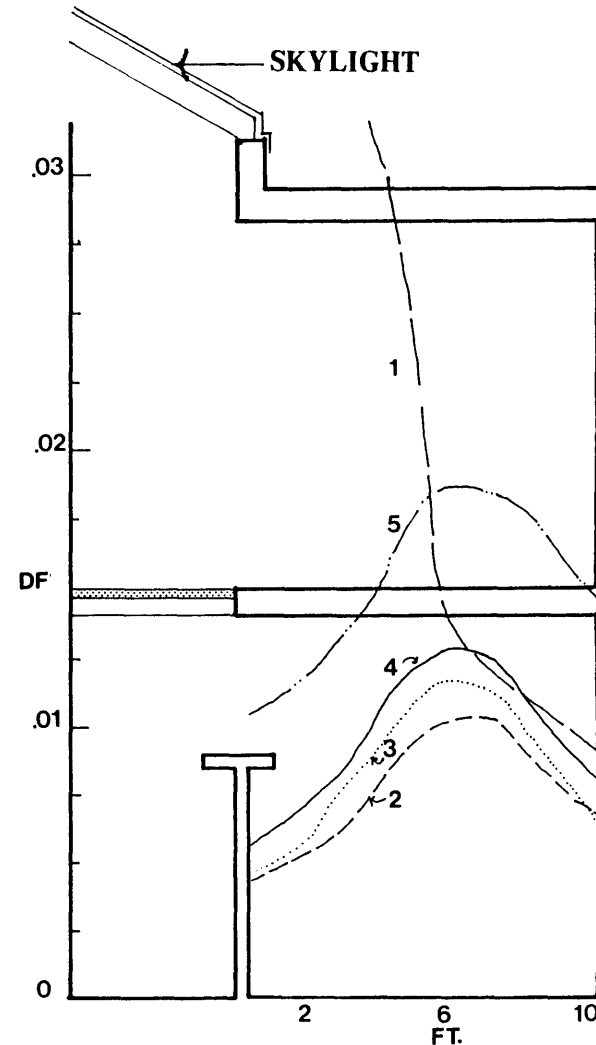

Fig. 44. Graph of room location in feet (FT) vs. daylight factor (DF) for several different light shelf and partition configurations, keyed to diagrams in fig. 45. Plotted over transverse section of typical bilateral corridor lighting scheme as modeled. Scale: (3/16"=1'-0"). Shaded material in drawing denotes portions of translucent floor; Typical all drawings.

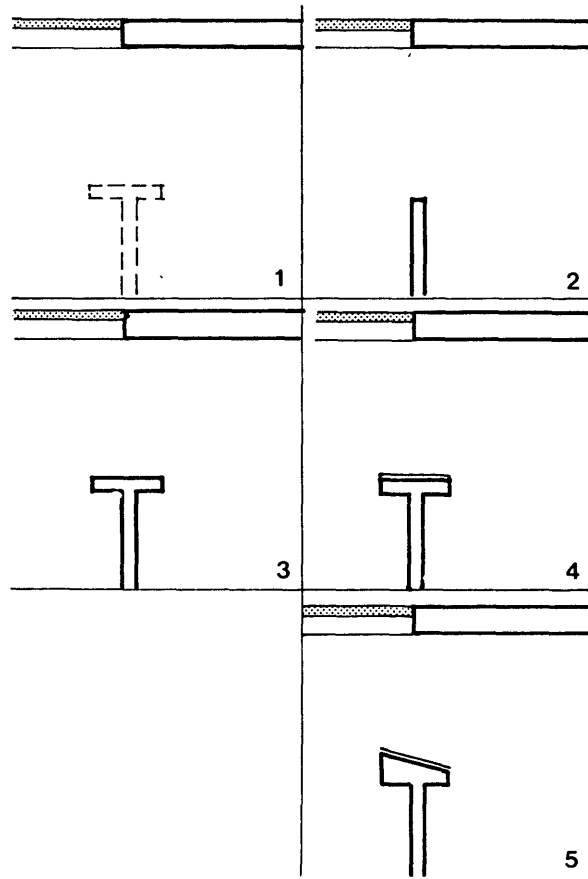

Fig. 45. Diagrams of a number of light shelf and partition configurations graphed in Fig. 44. KEY: 1.No partition or light shelf. 2. continuous 7'-0" high partition without light shelf. 3. continuous 7'-0" high partition with 2'-0" wide, level, white (80%), light shelf. 4.same as 3 with addition of mirror surface (100%). 5. same as 4 except light shelf is tilted 15 degrees toward receiving room.

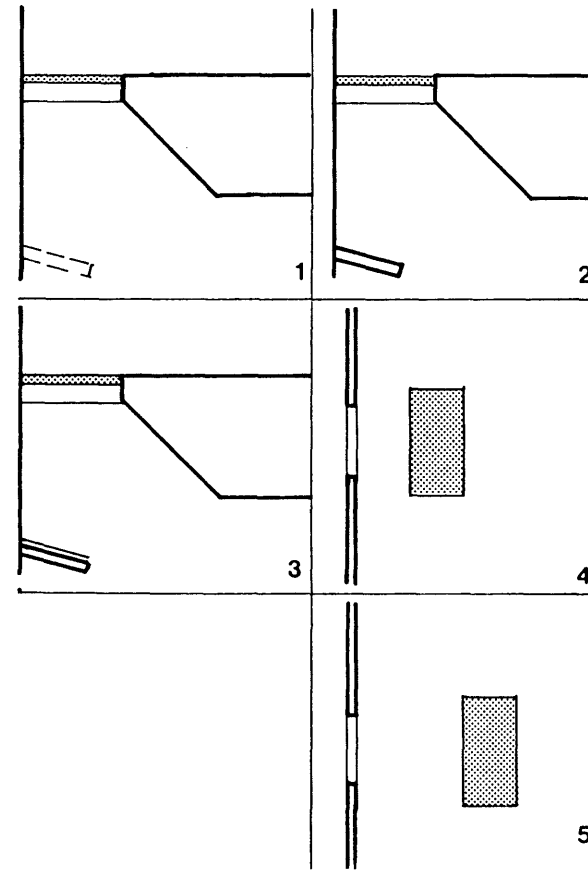

Fig. 46. Diagrams of five light shelf and floorlight variations plotted in Fig. 47. KEY: 1. unmodified well profile 2. with 2'- 0" wide white light shelf tilted 10 degrees to back of room. 3. same as 2 with addition of mirror surface (100%) on light shelf. 4. floorlight moved 3'-0" back from foot of window without light shelf. 5.floorlight moved 6'-0" back from window.

or provide daylight to subgrade spaces. There is a direct relationship between the location and orientation of the floor light to the source window, the addition and profile of a light shelf and the resulting daylight factor and its distribution in the room beneath. The relationship is such that as the floor light is moved in a straight line back from the foot of the window, the resulting daylight pattern is distributed further back into the room, but the daylight factor is decreased. Secondly, when a floor light is located at the foot of a window, the addition of a light shelf to the floor light system only serves to occlude the available daylight. This results in various distribution patterns, but decreases daylight factors overall.

This method of floor light application has some potential as an alternative to the troublesome exterior window well in both residential and commercial building types which utilize subgrade spaces. This alternative allows for the earth berming of the lower edges of the ground floor to reduce heat loss by eliminating the need for costly window wells. An example of the application of this method is included in the ground floor of the residential rowhouse prototype presented in the last chapter.

LIGHT BETWEEN THE WALLS

In conjunction with the development of a specific application to urban rowhouses in the last chapter, a linear sky and floor light combination placed adjacent to intervening party

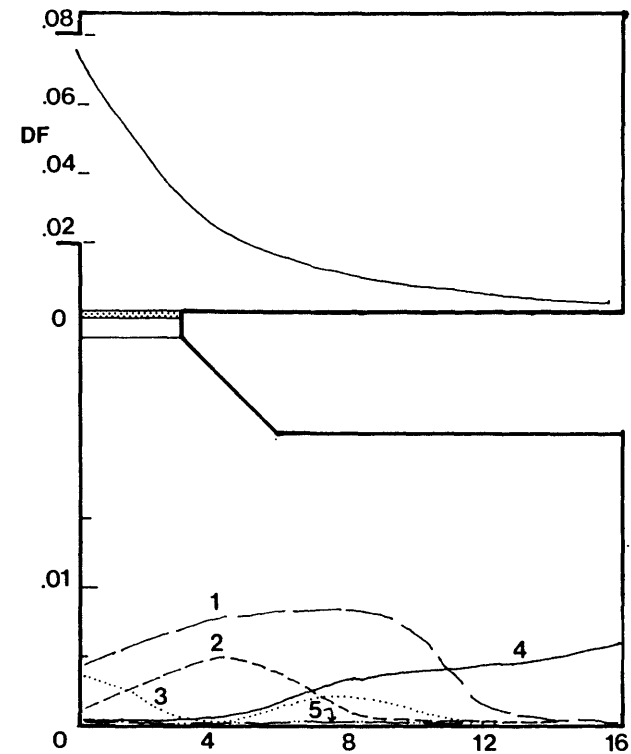

Fig. 47. Graph of location in cross section of modeled room (FT.)(scale: 3/16"=1'-0") vs. daylight factor (DF) for several different light shelf variations, side light and floor light locations (1-5) as keyed to diagrams in Fig. 46.

walls was studied. In order to develop the appropriate light well proportions for this application, the configuration was modeled with various skylight apertures.

It appears that there is a direct relationship between the size of the skylight aperture and the daylight factors via the floor light in the rooms below. This relationship is such that as the aperture of the initial skylight is increased, the resulting daylight factors in the room below via the floor light are also increased. The graph in fig. 48 results from the modeling of a 32'-0" long floor light and skylight in a 16'-0" wide space where the skylight is increased in width from 3'-0" to 4'-6" and finally 6'-0". Based on this graph a selection of the appropriate skylight aperture can now be made depending on the criterion for the level of core daylighting.

CONCLUSIONS

The basic daylighting relationships involved in the application of translucent floor systems have now been established through this physical modeling procedure. In many cases these relationships have been generalized so as to be applicable to a number of different situations and building types. Based on these general relationships and the actual modeling results in Appendix A, the following conclusions can be drawn in regard to the physical modeling and application of the translucent floor system:

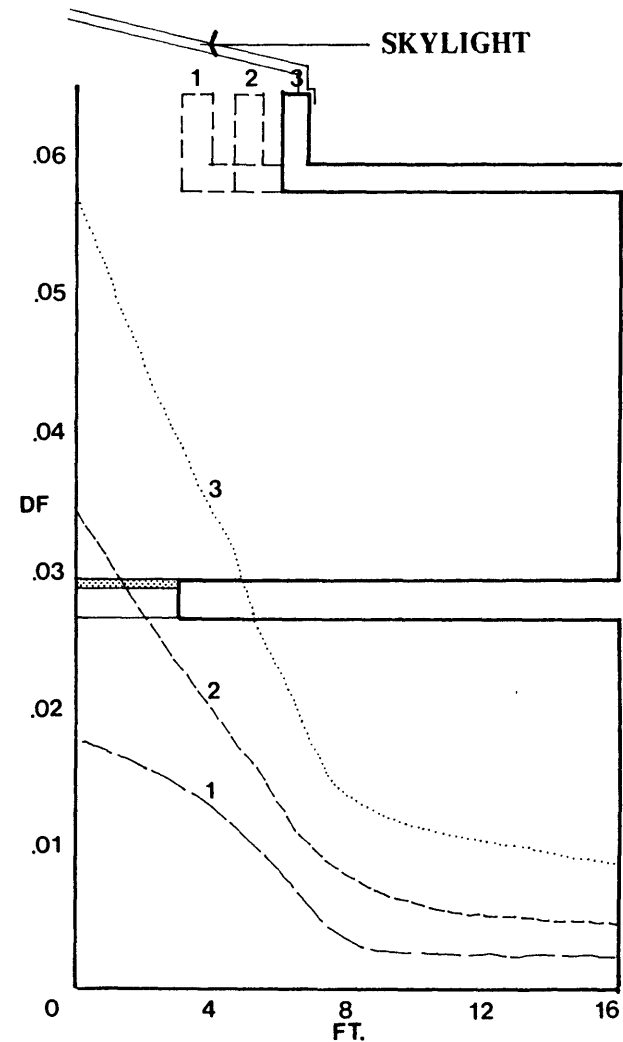

Fig. 48. Graph of location in cross section of modeled room (FT) (scale: 3/16"=1'-0") vs. daylight factor (DF) for three different continuous linear skylight apertures. KEY: 1. 3'-0" wide skylight 2. 4'-6" wide skylight 3. 6'-0" wide skylight. Shaded portion of drawing denotes areas of translucent floor.

1. Well indexes in excess of 3, regardless of floor light transmission, approach the limits of the daylighting effectiveness of the translucent floor system.
2. It is more effective to increase floor light aperture size relative to and moving down from the initial skylight than to maintain original skylight aperture or reduce it.
3. Increasing initial skylight aperture is the most effective way of improving daylight levels given the same floor light configuration.
4. With the exception of the initial skylit room, the quality of the daylight resulting from the translucent floor is glare free and in most cases evenly distributed within the room.
5. The quality of daylight distribution increases with each successive pass through the next translucent floor light down.
6. Small multiple floor lights and side light combinations are typically ineffective for daylighting other than circulation zones beyond one floor down from initial skylight.
7. Long, linear, stacked floor lights and skylights are more effective for daylighting than square apertures for the same area, but distribution suffers.
8. Although outdoor ambient modeling is effective in simulating sky illuminance distribution and actual daylight

conditions, for the purposes of multifold comparisons made during this modeling, the use of an artificial sky room which is a known constant may have been preferable.

It has become clear that in addition to other building characteristics, the transmission of the translucent floor system is a major factor in the feasibility and effectiveness of this concept. This chapter has been devoted to the modeling of the "light" characteristics of the floor light with little discussion of the other role of this technology. Equally as important, and closely interrelated, is the role as "floor" and the structural characteristics and properties which are primary to this function.

Chapter 4

TRANSLUCENT FLOOR STRUCTURAL SYSTEMS

The relationship of floor light transmission to structural integration is probably the most important aspect of the design and engineering of this daylighting technology. In many ways this horizontal application of glass lights or lenses within a structural frame or mullion is not unlike the the more familiar vertical application or window of which there are many examples. It is even more comparable to the skylight or conventional "horizontal window" which begins to approach the criterion for the floor system. The principles are, for the most part, the same. It is the magnitude of the loads and impact forces which are unique to this horizontal, load bearing application and distinguish it from the vertical translucent surface.

The magnitude of liveloads considered in the design of windows can vary from 20 psf to as high as 100 psf in some highrise applications. Although these loads seem somewhat comparable to horizontal liveloads, the consideration of impact and point loading proves to be the distinguishing factor. Nevertheless, the profile, depth and material of the intermediate mullions and the thickness, type and strength of the glass light form an integral pattern which serves to

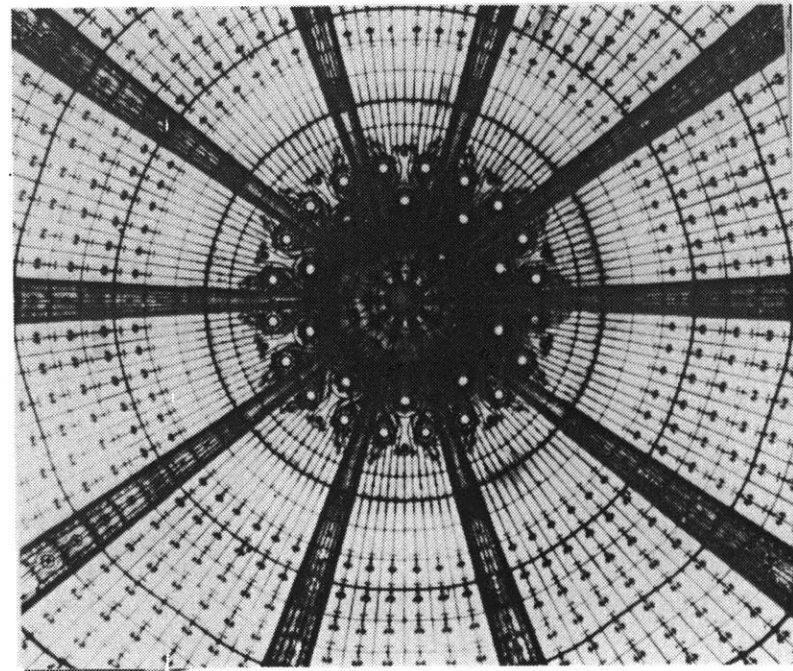

Fig. 49. A literal diagram of structure to glass ratio in nineteenth century domed skylight.

withstand these loads. The resolution of this pattern is a significant factor in the visual quality of the fenestration and the continuity of the architecture as a whole. This relationship is attested to by the ornate tracery of the rose windows of the gothic chathedrals or the wonderful domed and valted skylights of the late nineteenth century. On a somewhat more pragmatic note, the diagram in fig. 50 serves to illustrate this relationship between glass and structure in the selection of maximum mullion spacing for curtainwall systems.

GLASS AND CONCRETE

There are various types of structural systems which are applicable to horizontal, load bearing as well as vertical translucent surfaces. The first and most common system is the reinforced concrete rib or grid supporting individual glass lenses or blocks. This system can be employed as either a simple support structure merely supporting the isolated glass lenses or as a more interesting composite structure in which the compressive strength of the glass is coupled, through the grout, with the tensile force in the reinforcing steel. The incredibly high compressive strength of glass, in the range of 80,000 psi, suggests that it is a good candidate for this purpose. In the case of the isolated system, the glass lenses can either be set in place afterwards or cast in situ. However, with the composite system, the

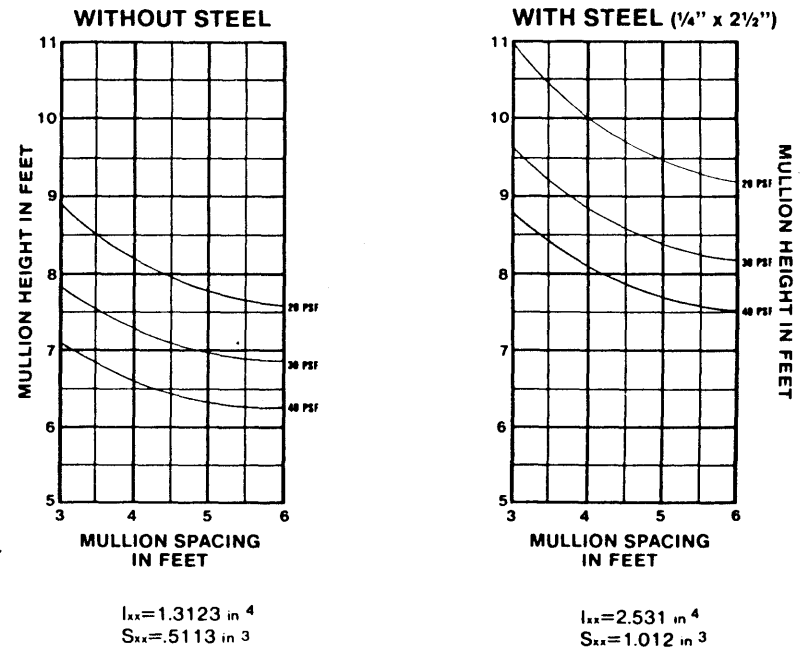

Fig. 50. Graphs of typical mullion spacings for curtainwall systems as a function of wind load.

lenses must be cast in situ with the reinforcing steel in place.

One of the characteristic material properties of glass and concrete is the lack of good adhesion at the interface of these two materials. This tendency for poor adhesion gives rise to another distinguishing characteristic of the composite lenses, which is the deformed surface features created in order to improve the adhesion of the concrete grout and the glass lens. This texture or deformation assures the necessary coupling of the compression in the lens and the tensile forces in the reinforcing steel.

Another peculiar behavior associated with this type of structural system during casting is the shrinkage stresses brought on by the curing of the concrete. These stresses, left unaccounted for, can easily fracture the glass lenses. In order to keep shrinkage in the concrete to a minimum, it must be cured slowly with a covering of a moist sand, sacking or the addition of a low shrink admixture to the concrete mix. In addition, for what little shrinkage does result, the glass lenses must be spaced apart by a strip of some compressible material, often cardboard. This strip is removed after full curing and replaced with caulk or a grouting material. Obviously, this procedure is unnecessary in the case of the isolated glass lens placed after casting.

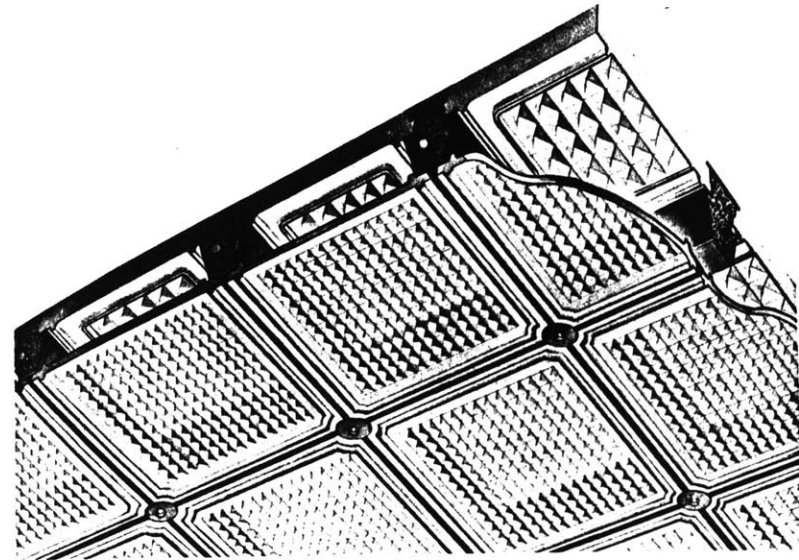

Fig. 51. Construction section of the improved Keppler System showing the deformed lens profile.

When this type of structural system is applied to skylights which do not require a flat level surface, as with the early work by the French, much of the reinforcing steel can be eliminated as the shape approaches a compression shell. Here the compressive strength of the glass is fully utilized as an integral part of the structure. However, in the application to floor systems, these shapes, except in very shallow vaults, are not practical. The most we can hope for is a partial participation of the glass lens in the structural system.

In order to maximize the light transmission of this system as a floor structure, the reinforced concrete ribs or mullions must be reduced to their minimum profiles. Consequently, the quality control in the placement of reinforcing steel and the concrete mix must be very high to assure a safe structure. It is for this reason that most of the commercial applications of this system employ precasting techniques which can be completed in a controlled factory environment. Although there is some economy to this factory precasting, the cost and possible damage of shipping as well as handling difficulties must be considered as some of the tradeoffs for this possible economy. Where skilled construction labor is dependable, as is the case in Europe, the field casting of this system is common.

GLASS LENSES

The sizes of the lenses which are typically used in the glass and concrete structural systems range from 4" x 4" (11.7cm



Fig. 52. The vaulted glass lens and concrete skylight over the Chantiers Station, Versailles, 1931.

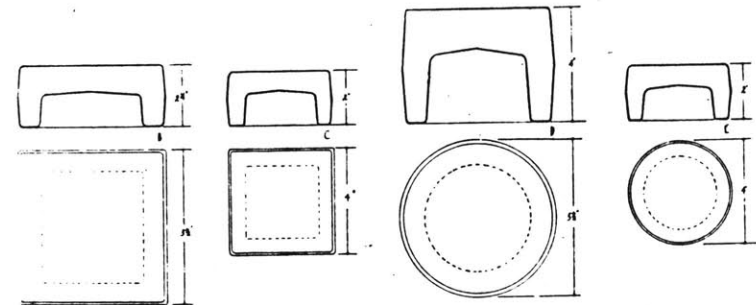
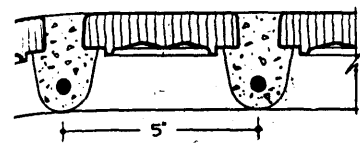
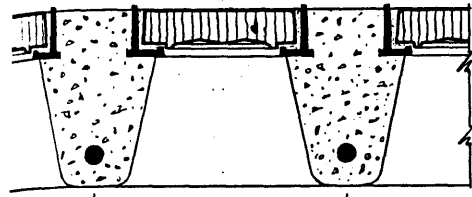

Fig. 53. Examples of various lens shapes and thicknesses.



FOR PAVEMENT TRAFFIC
 TYPE 16/238 - 5" CENTRES 2 3/8" THICK
 TYPE 16/262 - 5 1/2" " 2 3/8"



FOR RUBBER TYRED VEHICLES
 TYPE 16/425 R - 6 1/2" CENTRES 4 1/8" THICK

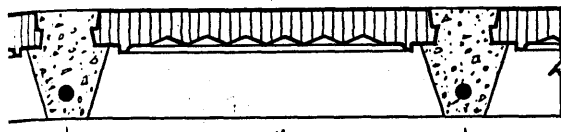

FOR ROOFS CANOPIES ETC.
 TYPE 34/281 - 10 1/4" CENTRES 2 3/4" THICK
 TYPE 34/325 - 10 1/4" " 3 1/4"
 TYPE 34/350 - 10 1/4" " 3 1/2"
 TYPE 34/400 - 10 1/4" " 4"

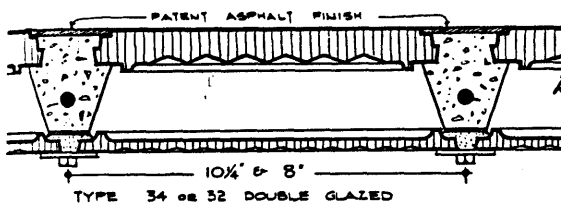

TYPE 34 OR 32 DOUBLE GLAZED

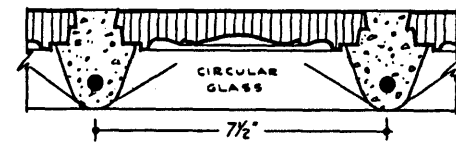

FOR FLOORS & ROOFS
 TYPE R 32/250 - 7 1/2" CENTRES 2 1/2" THICK
 TYPE R 34/325 - 10 1/4" " 3 1/4"

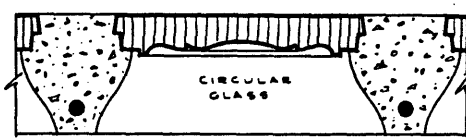

FOR DOMES CANOPIES ETC.
 TYPE RC 32/300 - 8 1/2" MIN. CENTRES 3" THICK
 TYPE RC 34/350 - 11 1/2" " 3 1/4"

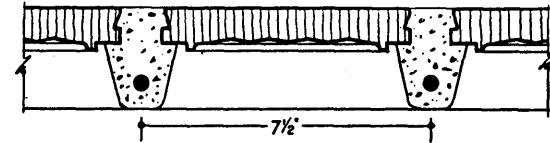

FOR FLOORS & ROOFS
 TYPE 32/250 - 7 1/2" CENTRES 2 1/2" THICK
 TYPE 32/300 - 8" " 3"
 TYPE 32/350 - 8" " 3 1/2"
 TYPE 32/400 - 9" " 4"

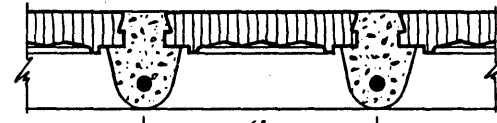

FOR FLOORS & ROOFS
 TYPE 17/238 - 6" CENTRES 2 3/8" THICK
 TYPE 17/425 - 7 1/2" " 4"

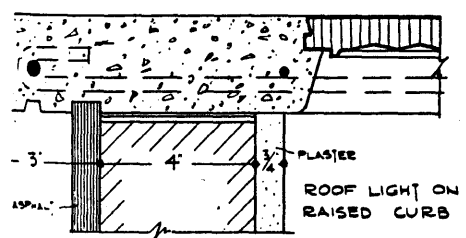
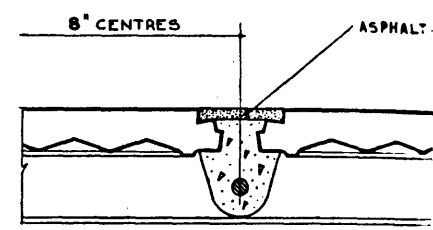
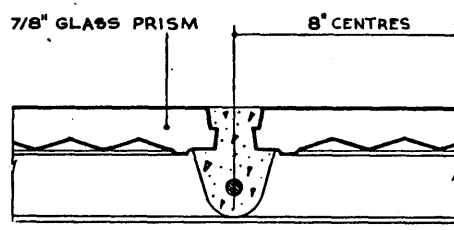

PLASTER
 ROOF LIGHT ON
 RAISED CURB

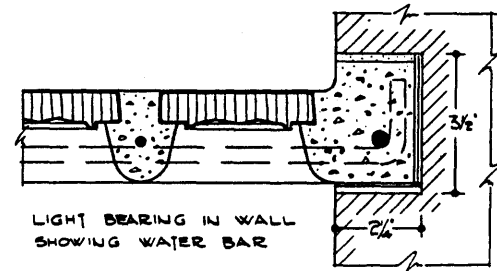

LIGHT BEARING IN WALL
 SHOWING WATER BAR

Fig. 54. Examples of various lens shapes, thicknesses and composite construction sections.

x 11.7cm) to 8" x 8" (20 cm x 20 cm) with various sizes inbetween. These lenses range from 1/2" to 1 1/4" (3 cm) in thickness and come in bottle or water white glass. The standard shape of the flat, glass lens is typically square or round, however some elongated rectangular shapes have been produced. Most of the early glass lenses for use in reinforced concrete systems provided an extended flange or lip around the edges. This flange was and is used for two purposes. The first purpose was to elevate the prism portion of the lens to the top finish of the concrete rib during field casting without increasing the thickness of the lens itself. The second purpose, still called for today, is to reinforce the edge of the lens and better distribute extremely heavy floor loads into the supporting concrete ribs. Now that most lenses are applied to precast grids, this flange detail is no longer required for the purpose of centering, however, it is still employed as a reinforcing detail in heavy duty applications.

COMPOSITE TESTING

In order to attempt to quantify and understand the propeties of the composite glass lens and reinforced concrete structural system, a full scale test panel was designed, fabricated and tested. Because of the limitations of testing equipment and handling, the test panel was limited to a dimension of 3'-6" long by 1'-4" wide and 3" deep. The panel consisted of 10- 8"x8"x3" Vistabrick [®] glass lenses, which were



Fig. 55. Steel frame and glass blocks of composite test panel prior to grouting.

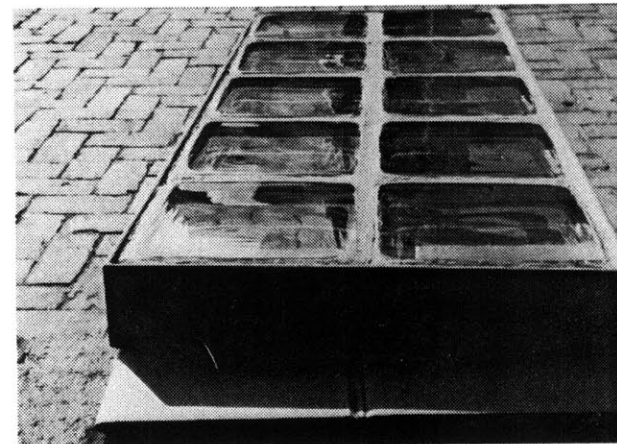

Fig. 56. Completed composite test panel showing comparatively narrow grout joints.

supplied by the Pittsburgh Corning Corporation, a welded steel frame with a 8"x8", no. 3 reinforcing steel bar grid, and a non-shrink, high strength grouting material under the trade name of Thorogrip.

The lenses were grouted into the 3/16"x 3", 36 ksi steel frame in order to better approximate the composite coupling of compressive and tensile forces which would exist in a larger panel section bounded and constrained on all four sides. The assumption was made that without this compression ring of either steel or reinforced concrete, the compressive capacity of the glass lenses would not be utilized because of the low adhesion values of the glass and grout. This test panel also represents a possible variation in composite systems with the employment of the steel frame compression ring.

The test panel was allowed to cure for 14 days before testing. The tests were conducted on a Baldwin 60 k loadtesting machine in the structural testing laboratory of the Department of Civil Engineering at MIT. The panel was tested in simple bending over a span of 2'-8" with a line load at mid span ranging from 0 - 10k. Curve 1 in the graph in fig. 57 shows the load vs. deformation curve exhibited by the composite steel frame panel during testing. This curve shows that the panel exhibits elastic deformation in the load range of 0- 5 k at which point it begins to yield at the mid span joints of the glass lens and grout. In

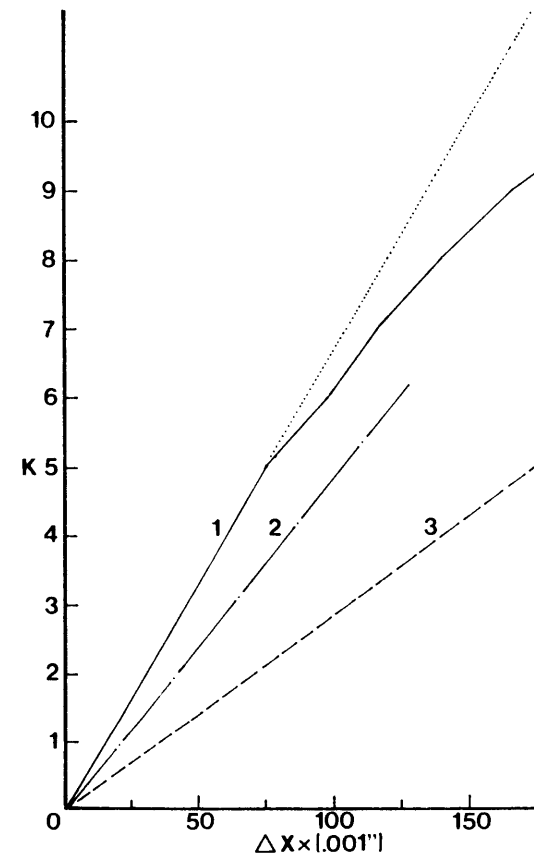

Fig. 57. Graph of test panel deflection $\Delta X \times .001$ inches vs. line load applied at mid span. KEY: 1. composite panel including steel frame. 2. steel frame members separately. 3. reinforced glass block with resistance of steel frame members subtracted out.

order to separate out the bending characteristics of the steel frame compression ring from the composite panel, the steel frame members were loaded separately. The load vs. deformation curve which these frame members exhibit separately is plotted below the composite curve (curve2). The net bending resistance of the composite assembly is plotted as a third curve which would be exhibited if the steel frame were not present (curve3). It is possible to calculate the safe maximum one-way, simple span for this composite based on a combined live and dead load of 150 PSF and a maximum deflection of $1/360$. Given an EI (modulus of elasticity x moment of inertia) for the composite panel of 13,000,000 psi (the difference between curve1 and curve2), the maximum safe span would be 5'-2". Based on this span it is possible to derive the placement of secondary structural members and determine the overall light transmission of multiple panel assemblies.

In addition to the performance of this composite panel in simple bending, the test also provided data on the shear resistance of the glass lens and grout joint. The local configuration of the test panel was such that the concentrated line load, applied to the top of the panel, was never in direct contact with the steel side frames of the compression ring. This situation assures that the full concentrated load rested on the glass lens and grout joint itself and not the steel side frame. The concentrated line load test passed a 5

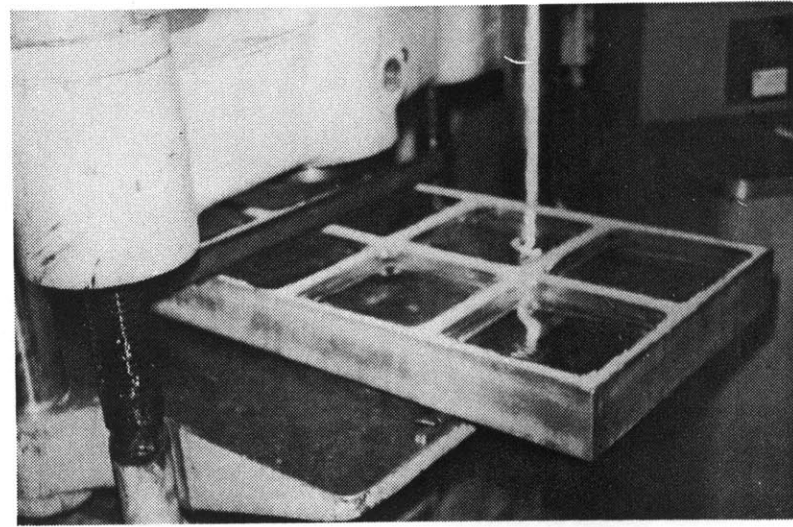

Fig. 58. Test Panel in place on platform under concentrated line load.

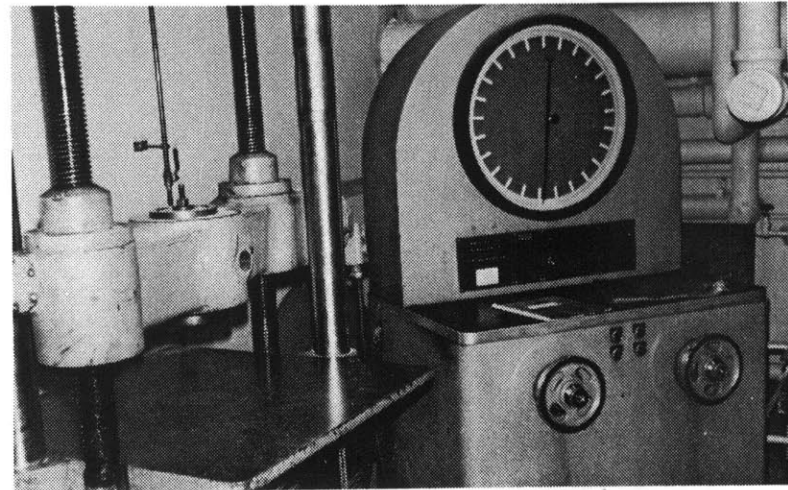

Fig. 59. Structural testing apparatus showing the 60k Baldwin load testing gauge and platform.

kip load through the glass lens and grout joint to the rest of the panel structure before any local failure was observed. The shear resistance at these joints is very encouraging considering the limited engagement of the lens profile. This test suggests that even slight deformations in the edges of the the glass lens are effective in transmitting shear stresses through to the grout and steel rib.

Because of the limited financial, material and time resources involved in this thesis, this test is quite limited in its scope of application. However, it probes an area, despite its limitations, which is rich with the potential for improvements in the understanding of the mechanics of the translucent, reinforced concrete and glass, composite floor system. Furthermore, this test panel and the type of composite system it suggests, results in a light transmission of 70%. The existing glass and concrete floor light panels which are currently available in this country through the Circle Redmont Corp. and in Europe through the Westerwald Ag. offer maximum light transmission values in the range of 40% to 50%. The improved light transmission value offered by this experimental composite represents a 30% improvement over the values of existing floor light panels.

It should be noted that due to the experimental and limited nature of this composite testing program, neither the Pittsburgh Corning Corporation, through its provision of product samples, nor the author recommends the application



Fig. 60. A view looking down through test panel.

of this panel detail in any actual building situations. This testing exercise is only meant to explore the potential of the composite panel concept and must undergo much more extensive testing before any recommendations regarding implementation are possible.

STRENGTHENED PLATE GLASS AND STRUCTURAL STEEL SYSTEMS

Another type of structural system which is employed in this technology is the cast iron or structural steel frame or grate. This system is related to the non-composite reinforced concrete system in that it merely supports the glass lens and does not derive any added strength from the presence of the glass. In reviewing this structural system, it is important to keep in mind the evolution of cast iron to steel and the resultant impact on the integration with the glass lens and the light transmission properties of the system. Although both cast iron and steel allow for a multifold improvement in the light transmission values of this system, it is ultimately with the steel structure that the greatest strength is achieved. It is this increased tensile and bending strength over reinforced concrete which allows a further reduction in structure profiles and consequently a marked improvement in the light transmission values.

Consistent with the development of metalurgy some of the early examples of this system include the cast iron plates in which relatively small glass lenses were grouted. These cast

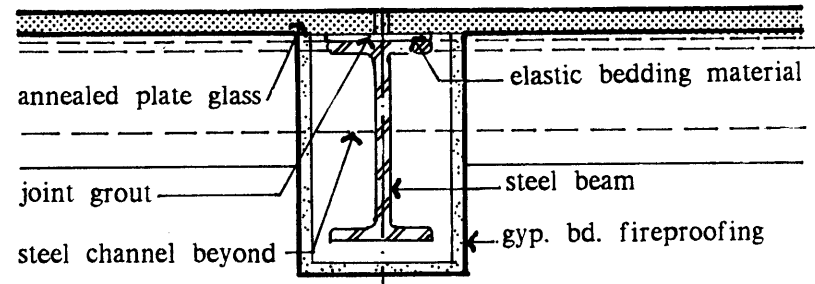

Fig. 61. Construction section of plate glass and structural steel floor light system. (scale: 1 1/2" = 1'-0")

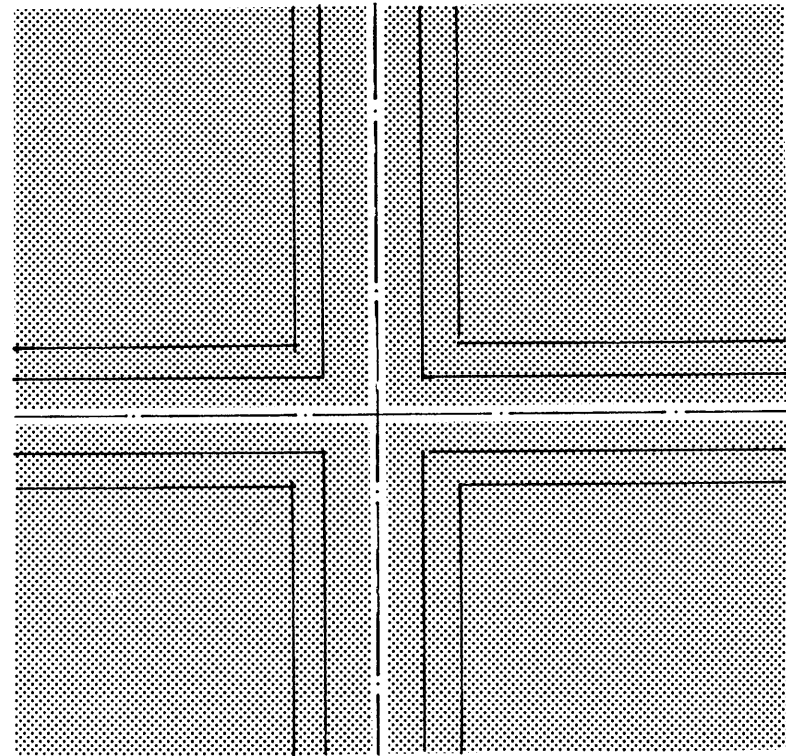

Fig. 62. Plan detail of plate glass and structural steel floor light system. (scale: 1 1/2" = 1'-0")

iron systems were applied to stair risers, manhole covers and various types of sidewalk vault illuminators, but there are few examples of any bonafide architectural applications. It is not until the rolling of iron and finally steel into relatively efficient structural shapes that the potential of this system is fully exploited. The increases in light transmission values possible in this system would only be partially achieved if it were not for a concurrent improvement in the strength and durability of the glass lens. As processes of chemical and heat strengthening emerged in the plate glass industry, the capacity to produce much larger lenses became possible. It is now possible to achieve spans of 3'-0" or 4'-0" with strengthened plate glass lenses as thin as 5/8" under floor live loads of up to 100 p.s.f.. Recent developments in glass strengthening such as safety laminates promise to further increase the potential spans of the translucent lens element.

The combination of high strength structural steel shapes and the strengthened plate glass lens begin to approach the limits of the increased light transmission values possible in this structural system. The safe spans of the glass lens have been maximized and the reduction of the profiles of the primary structural members have reached their safe minima. Although this structural system has been applied in limited architectural contexts, such as the library stack and reading rooms, cited earlier in chapter 1, there are no insurmountable problems

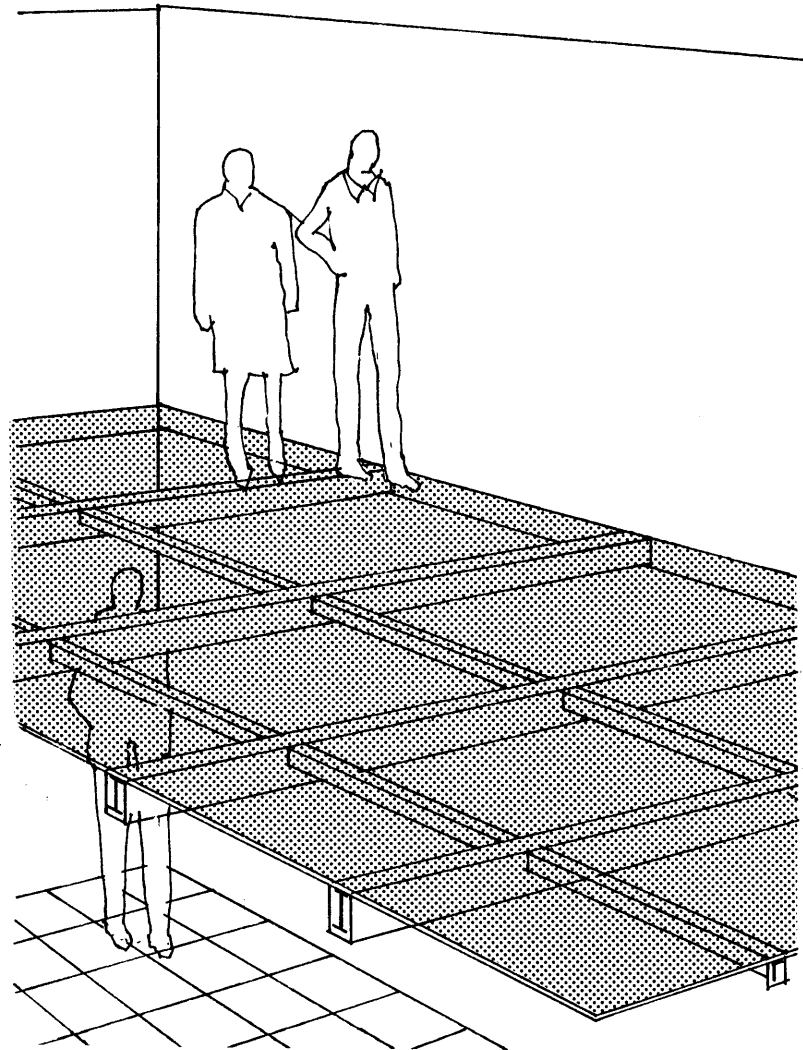

Fig. 63. Sketch of a typical plate glass and structural steel translucent floor system. Shaded portions of drawing denote extent of translucent lens.

which prevent its application to a much wider range of building types for the purposes of daylighting and the visual quality of the interior environment.

CONCLUSIONS

In regard to the investigation and testing of the integration of structural systems in the translucent floor the following conclusions can be drawn:

1. The light transmission of the translucent floor is directly related to the type and degree of integration of the structural system.
2. The composite action of the glass lens and the steel reinforcing offers the highest light transmission values for the glass and concrete structural system.
3. Glass and concrete panel fabrications require high quality control and precautions against shrinkage stresses in the glass lens.
4. Plate glass and steel systems offer the highest possible light transmission but are not as durable as the smaller lens in the glass and concrete system. They are also not as fire resistant as the glass and concrete system as will be discussed in the next chapter.

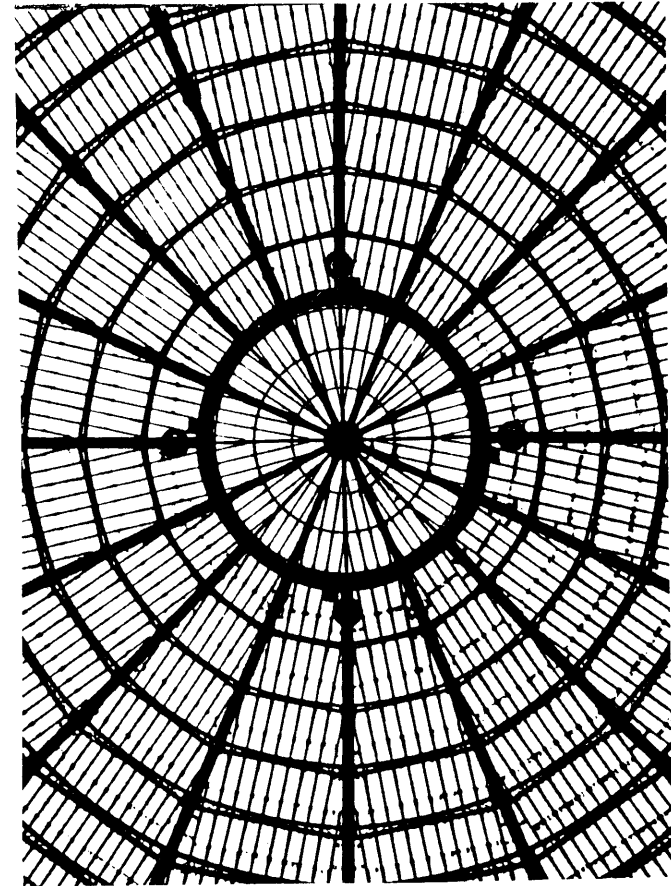

Fig. 64. The domed skylight of the Galleria Umberto, Naples.

Chapter 5

CONCEPTS OF INTEGRATION WITH ARCHITECTURE

Buildings are not solely vessels to distribute daylighting. They are made up of many different overlapping systems and functions, all of which must be resolved into one harmonious whole. Before the translucent floor system finds its appropriate place among these many other systems, it is important to look at a number of interfaces with other isolated building systems and functions. While looking at the interfaces with these other systems, this technology will be evaluated with respect to its compatibility with each system.

ARCHITECTURAL SYSTEMS

In terms of general organization, most architecture can be broken down into five broad system categories: structure, circulation space or corridor, programmatic activity space or room, environmental or mechanical and lighting. There are certainly other sub-systems which can be further defined as they relate to these basic categories, but for the purposes of simplicity and understanding, the analysis will be limited to those outlined. The Preceding chapter has evaluated many of the issues related to the integration of daylighting and structure in the translucent floor system and that discussion will suffice for the purposes of this chapter. In terms of

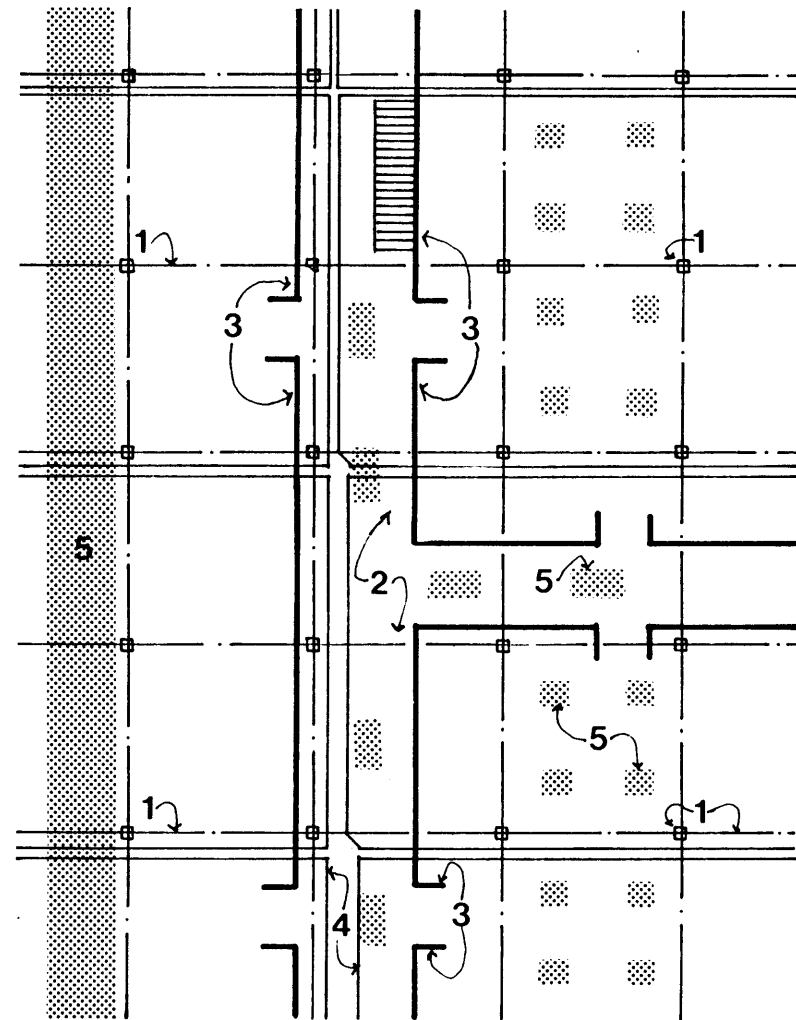

Fig. 65. Typical schematic plan overlay of five primary architectural systems. KEY: 1. structure, 2. circulation, 3. programmatic activity or room, 4. Mechanical, 5. Artificial and Natural lighting.

building organization, the other architectural systems most fundamental to the integration of this technology are the placement of circulation spaces or corridors, programmatic activity space or rooms and daylighting.

SPACE FOR DAYLIGHT

Traditionally, beyond the perimeter of a multi-story building, where toplighting becomes the only way to get daylight into the building, there has been a duality of systems. There is a creation of space for light and space for circulation and programmatic activities. The duality of these two combined organizational and technological systems gives rise to a proportion and density of building form which is prototypical. If circulation and activity zones can be thought of as solid and daylighting zones as void, then the daylit building becomes a pattern of solid and void, interwoven but still separate overlapping systems.

So far, these zones are merely adjacent and the function of the circulation and programmatic activity zones does not interfere with that of the daylighting zone to any great degree. The light atrium is a good example of this zonal relationship. Most of the atrium space is reserved for the distribution of daylight, while the periphery, floor and walls of the atrium are lined with the circulation and activity zones which share the daylight from this space.

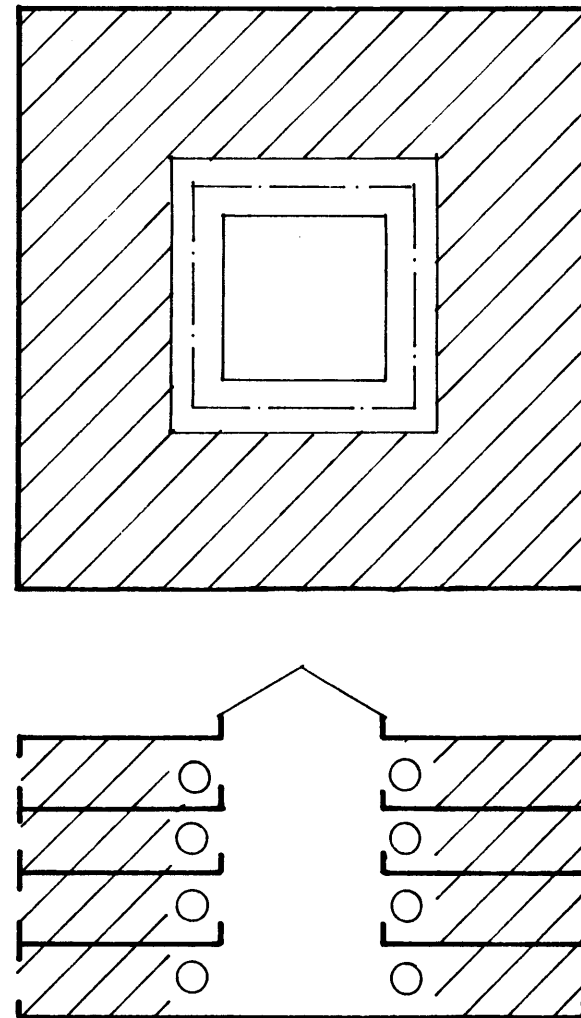

Fig. 66. Schematic building plan and section depicting the proportion of floor area to atrium of traditional toplighting concept. Cross hatching denotes usable floor area; circles and dot-dashed line denote circulation paths.

DAYLIGHT AND SPACE

In contrast, the application of the translucent floor system for daylight distribution, represents an integration of at least two of these zones, daylighting and room or corridor, in the most fundamental way. This overlap of systems on the floor plane poses new considerations in the design of buildings.

In order to merge these two zones, their activities and functions must be viewed in terms of the relationship of the relevant parameters of each system. In the case of translucent floor systems and the room or corridor zones, these parameters are the relative translucency of these functions with respect to traffic volume, density of equipment or furniture, occupancy capacity and visual privacy.

The room, taken here to mean a definable program function, is characterized by focus, requiring some degree of visual privacy, sustained occupancy and the presence of furniture or equipment. Each of these characteristics implies a diminishing of translucency. Obviously, focus and sustained occupancy, typical of a work station or conference room, fill a given space for a relatively long time duration. In addition, the presence of opaque furniture necessitated by these activities further increases the opacity of these spaces to light. The tendency towards opacity of these spaces tends to conflict with the function of daylight distribution and consequently discourages the placement of floor lights in these zones. In addition, the degree of focus and visual

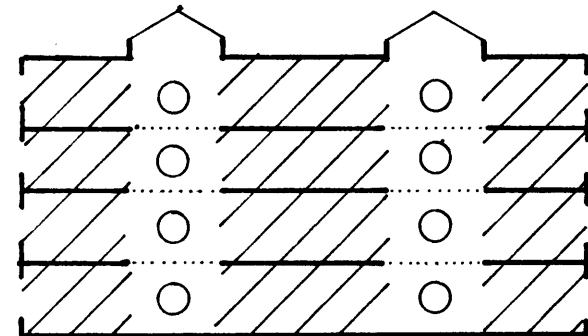
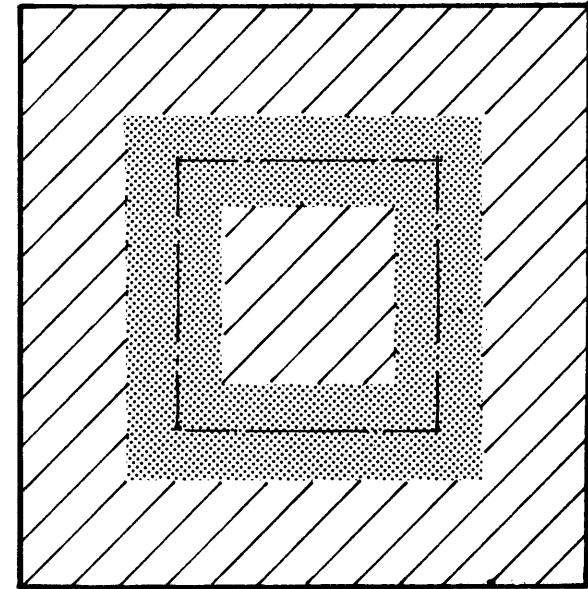

Fig. 67 Schematic building plan and section depicting the overlap of daylight and circulation in the shaded portion of the plan.

privacy required in certain programmatic functions is more prone to be disrupted by fluctuations in daylight level resulting from movement overhead. It is important, however, to be sure to reduce each program function to its smallest possible activity module to locate the various degrees of translucency within the space. For example, a programmed general office space is often made up of many individual work stations which are intermeshed within a general circulation pattern. Likewise, a large conference room, though a focused room environment furnished with a table and chairs, is skirted by a peripheral circulation space to provide access to the activity module itself. It is hard to develop any absolute rule for the compatibility of translucent floor systems to specific room uses. It should rather be left to the judgement of the architect and the owner given the specific circumstances of the project. This kind of design judgment is not unlike the placement of vertical translucent materials in similar situations.

The corridor per se, on the other hand, is characterized by movement, absence of furniture, distraction, and brief occupancy. As compared with the programmatic function or room, no one space is occupied for any extended period of time. This is in fact a code definition of a corridor or egress space. In terms of translucency, these characteristics tend to give this zone a relatively high value. For example, this form of functional translucency might be measured in

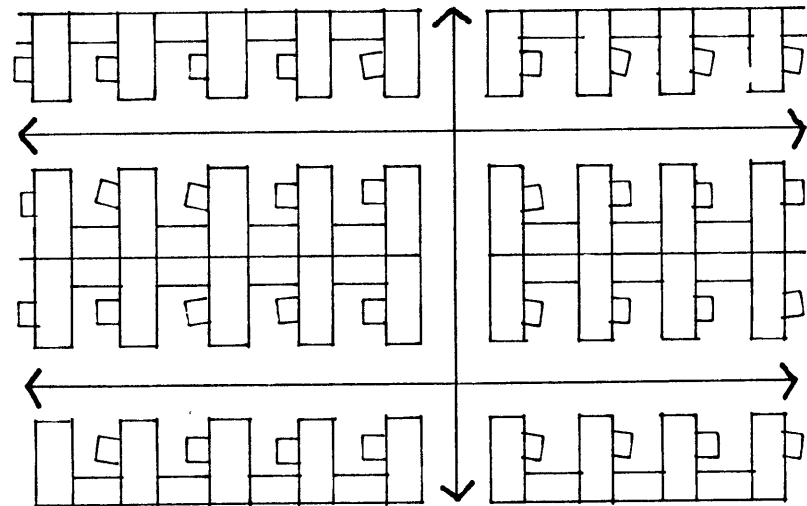

Fig. 68. Schematic plan of a typical general office area diagramming the intermeshed circulation pattern within the layout of the work stations.

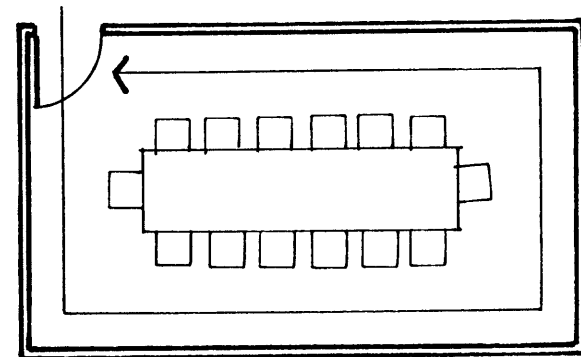

Fig. 69. Schematic plan of a typical conference room diagramming the peripheral circulation path within the room.

terms of person hours per square foot of floor area. In addition to this high functional translucency, the activity which occurs in circulating, which is already distracting by nature, is less prone to be disrupted by subtle variations in daylight levels resulting from traffic overhead.

SCHEDULING AND DAYLIGHT

The degree of institutional scheduling, such as class schedules in school buildings or coffee and lunch breaks in commercial and government buildings, is another important consideration in determining the compatibility of programmatic functions, circulation zones and translucent floor daylighting. The concept of regular alternating occupancy between circulation and programmatic activity zones allows for the coordination and placement of translucent floor technology in the circulation zones to provide effective daylighting in various rooms. In the case of the school building, for example, the placement of translucent floor systems in the corridors allows daylighting of the classrooms during class periods, when there is little traffic in the hall. On the other hand, between classes, when the halls are full of circulating students, the translucency of the hall diminishes to levels adequate for circulation. The resultant drop in daylight levels in the classroom during these periods is inconsequential as no class is in session.

This concept of alternating occupancy can follow longer cyclical periods than the school hour. In the case of one of the early examples of translucent flooring, the Restaurant

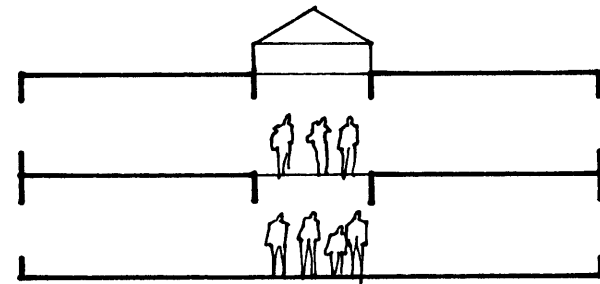
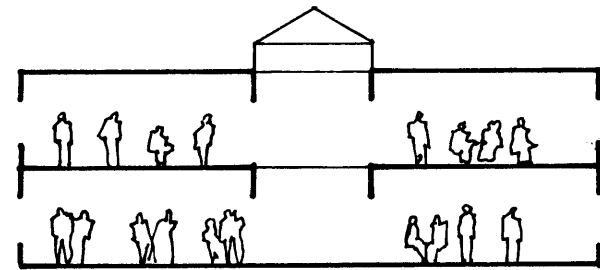

Fig. 70. Schematic building sections showing the concept of alternating occupancy between corridor and room function.

Ratinauld, Paris, 1911, the dance floor in the level above the restaurant employed a translucent floor. During the daylight hours for breakfast and lunch, the dance floor is not in use and serves to provide daylight to the dining room below, while at night, the floor is filled with dancers and the candle light from beneath makes for a delightful effect. It is not always the case that this type of scheduling concept exists in the architectural program, but when it does it creates a favorable environment for the application of the translucent floor.

DAYLIGHT AND BUILDING ECONOMICS

The integration of floor space and daylight manifest in the translucent floor has some profound implications in terms of building economics and daylighting. Where the traditional atria or light well offers some amenities of daylight and community space, at the same time, they must trade off access and floor area to do so. As much as developers want to add the atrium and raise the cost per square foot of the lease based on the improvement of the amenity, they also see the vast area of leasable floor area which must be cut out of each floor to achieve it. The translucent floor light integrates the amenities of daylighting, community space and the economics of leasable floor area. Instead of one large four story atrium of say, 5,000 s.f., the application of the translucent floor in this case would allow the creation of

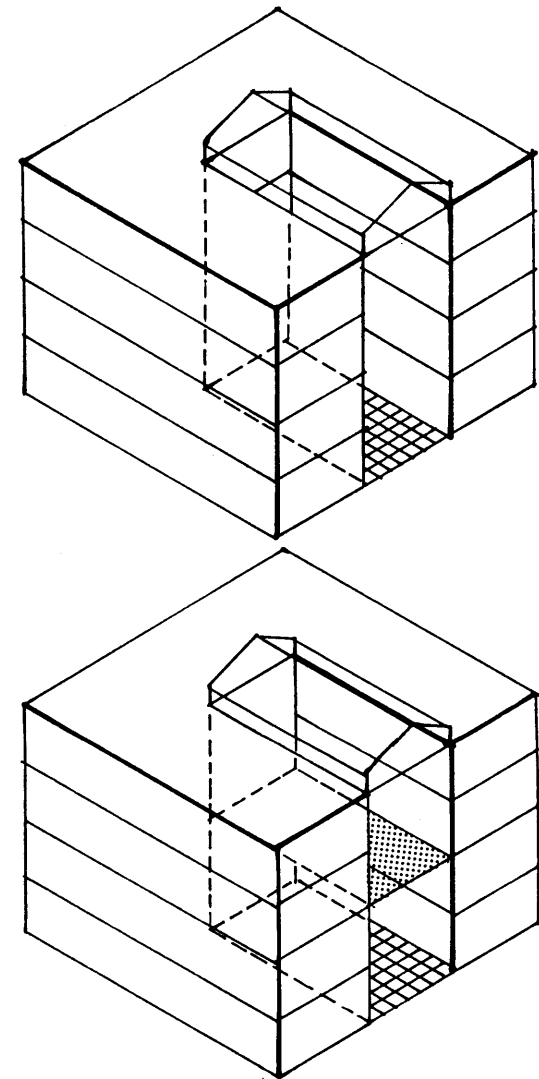

Fig. 71. Isometric building diagrams showing multifold increase in usable atrium space. Top: traditional single atrium configuration. Bottom: double stacked translucent atrium spaces.

two or three atria at 5000 s.f. each resulting in a total of 10,000 s.f. to 15,000 s.f. of leasable floor area.

MECHANICAL AND ELECTRICAL SYSTEMS

The preceding section has covered the compatibility of the translucent floor to the programmatic activities upon the floor. The next question of integration deals with the mechanical and electrical systems which traditionally fall between the floor and ceiling. In the case of the translucent floor, the ceiling and the floor are integrated into one system leaving no room in these areas for the mechanical plenum or electrical chase.

One method of integrating these systems with the translucent floor system is to expose them beneath the floor light utilizing their surfaces as diffuser elements for the further distribution of the daylight. The rounded surfaces of the elements used in these systems are ideal for the even spreading of light across the adjacent ceiling areas or the sides of the floor light well.

Another method of integrating these systems with the translucent floor is similar to the traditional atrium or skylight penetration through the ceiling or floor. Like these other daylighting concepts, the translucent floor does not represent all of the ceiling or floor area, but rather, only portions of this total area. Consequently, the plenum or horizontal chases of the mechanical and electrical systems

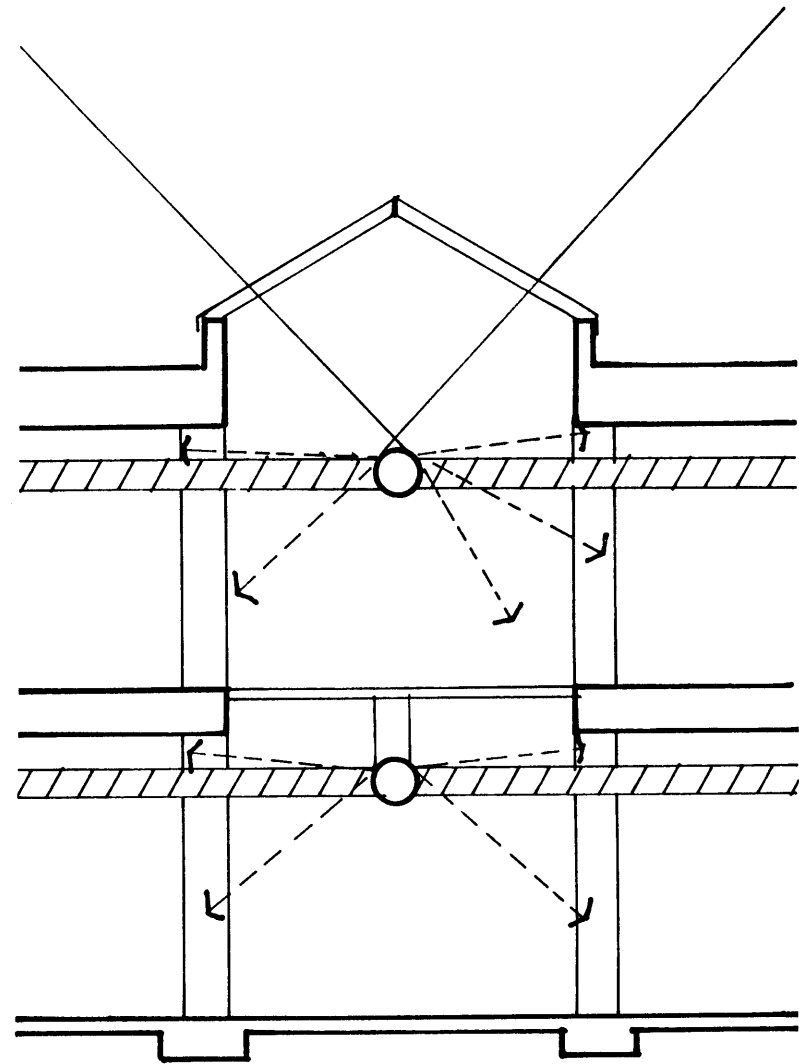

Fig. 72. Schematic building section with exposed mechanical ductwork acting as diffuser element in daylighting system.

can be concealed within the areas of traditionally hung ceilings and coordinated with the floor light openings in the same fashion as is done with other types of daylight openings. It is not surprising that the integration of the translucent floor system with these other systems finds ample precedence in the other traditional toplighting concepts. After all, these concepts are all based on similar principles and are merely different ways of achieving the same end under varying degrees of building density.

ARTIFICIAL LIGHTING

The integration of the translucent floor light with the artificial lighting systems is similarly not unlike other toplighting schemes. One of the economies of providing the translucent light shaft in a building is the improved efficiency and effectiveness of higher intensity lighting. These high intensity lights are placed in the same location as the initial daylight source and can either contribute to the daylight levels during especially dark days (below the established daylight standard) or totally replace it during evening use. Although there is not as much economy in doing so, individual floor light well cove lighting is another method of providing an integration with artificial lighting. However, unlike the traditional cove lighting concept, in the application to the translucent floor light, this concept projects light both to the floor above as well as below. The advantage of this method is the increased selectivity and

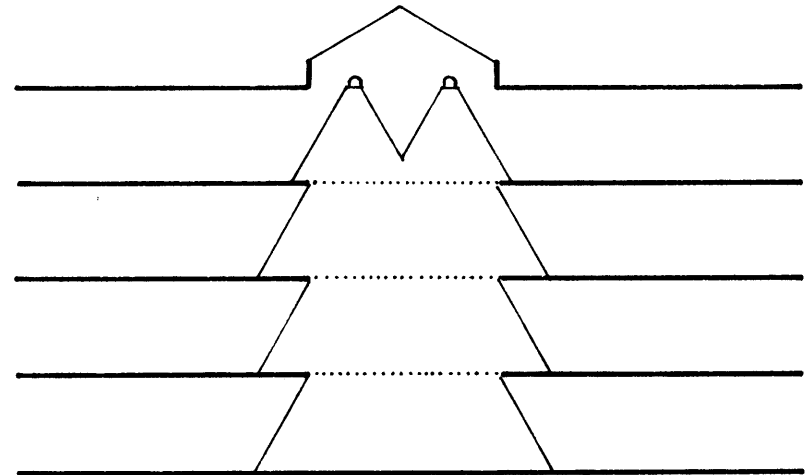

Fig. 73. Schematic building section showing location of high intensity artificial lighting to assist or replace natural daylighting over translucent floor areas.

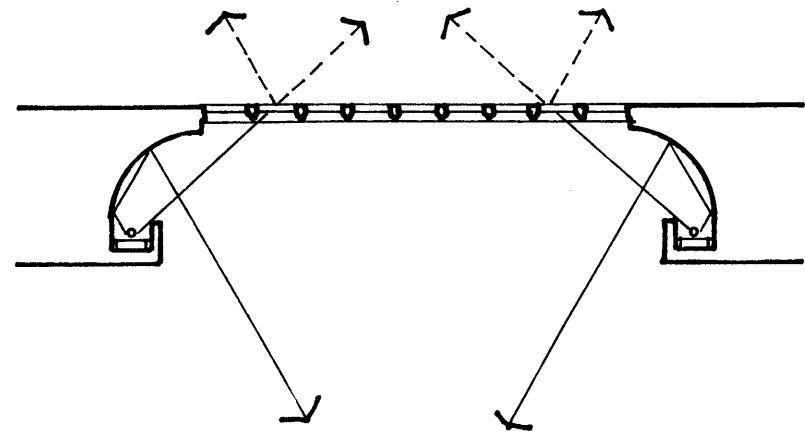

Fig. 74. Translucent floor cove lighting detail.

more localized control of artificial lighting levels on various floors throughout the building.

LIFE AND FIRE SAFETY

Much of the initial planning which goes into a building involves acceptable standards of life and fire safety with respect to the various systems within the building. In the area of multistory open shaft toplighting or atria daylighting concepts, these standards in the form of state and regional building codes, pose a number of serious constraints regarding their form, volume, extent and proximity to other parts of the building. Many of these constraints can seriously jeopardize the daylighting effectiveness of these open light shaft concepts.

The translucent floor system represents an integrated approach to the resolution of these life and fire safety code issues with respect to light shafts within the building. The construction of the floor light effectively integrates the properties of fire separation and resistance with those of translucency. The precast reinforced concrete translucent floor panel currently marketed in Europe and the U.S. has received fire resistance classifications of 90 min. in the U.S. and 2 hrs. in Europe. With these fire resistance ratings, the translucent floor panel can replace the opaque one hour wall assemblies separating most adjacent spaces from the atrium and replace them with the required fire resistance in the floor assembly. In limiting the penetration

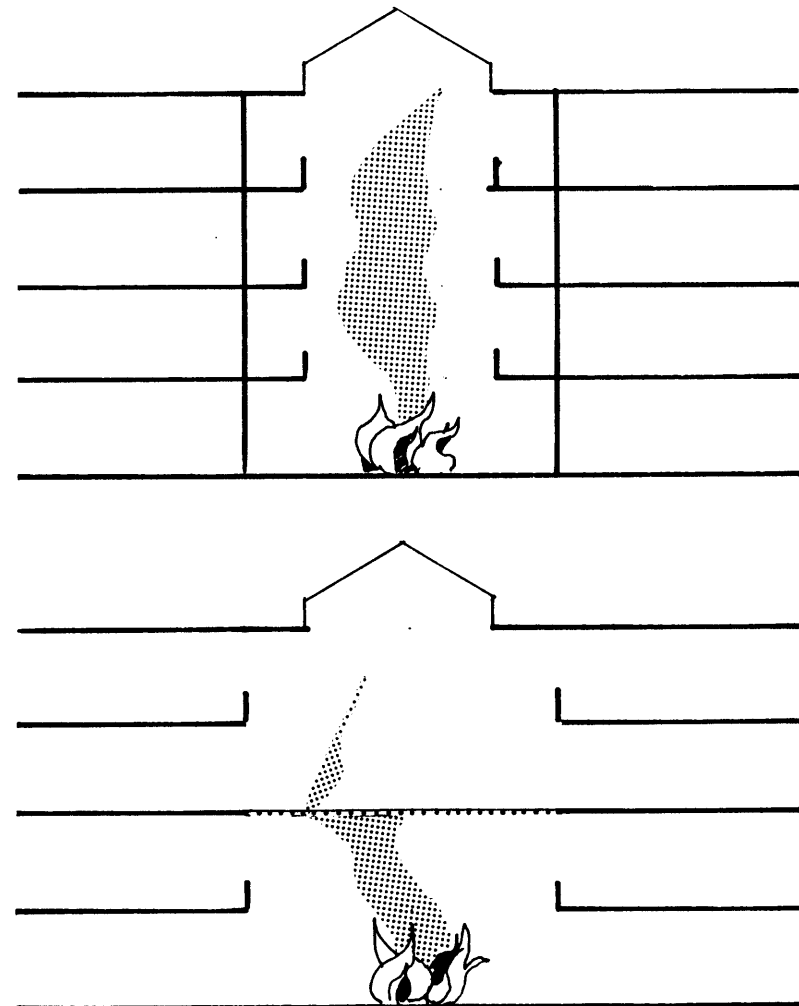

Fig. 75. Two comparative schematic building sections diagramming fire safety implications of atria and translucent floor system. Top: traditional atrium with required provision of 1 hr. fire separation. Bottom: double stacked translucent atria providing fire separation in floor plane.

of the open light shaft to only two stories and yet allowing the further penetration of the daylight through the floor, the floor light has allowed the full daylight potential of the atrium to be achieved. Unfortunately, these fire resistance ratings do not apply to the plate glass floor systems mentioned earlier and the further potential of this type of floor system is not as yet capable of this kind of integration. Nevertheless, improvements in the composite reinforced concrete light transmission characteristics suggested in the preceding chapter are capable of this integration and offer a further potential for this application.

FLOOR AND CEILING FINISHES

The system of architectural finishes in the floor, ceiling and walls are the final refined words through which the architecture speaks its visual language. In most cases the architectural finish is merely a superficial coating to the structure beneath. In the translucent floor system, however the floor and ceiling finishes become integral parts of the daylighting system and together they transcend the floor and ceiling plane as we know them.

In the translucent floor, the patterns of floor and ceiling decoration take on a new and more powerful architectural meaning, for the language of light has now entered the vocabulary. The quality of translucency, both up from the floor and down from the ceiling, has added a new dimension to these architectural finishes. The variations in

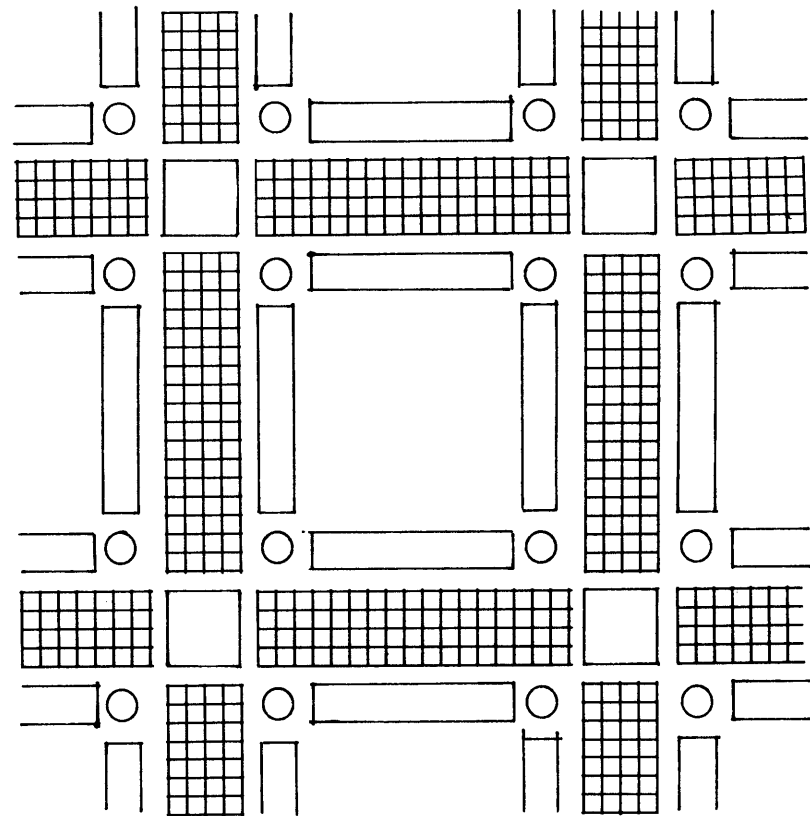

Fig. 76. An example of the variety of possible translucent paving patterns in the floor and ceiling.

color, texture and paving pattern are limitless and offer the architect a new world of alternatives to the lay-in acoustical tile ceilings and carpeted floors. All the variety of building fenestration can now be applied to the floor and ceiling as well as the walls.

The integration of the translucent lens into the floor finish has been instrumental in determining the various dimensions and textures of available floor lenses. Given the slippery characteristics of polished glass surfaces, the consideration of safety traction on floor lights has established a maximum paver size. This paver size is of a dimension such that the footprint of the pedestrian always overlaps some portion of the concrete rib, thereby providing some slip resistance. In addition, most paver surfaces are sandblasted or provide a raised pattern in order to further reduce this hazard. In the case of the plate glass translucent floor systems, where the lens size exceeds this slip resistant dimension, various types of textured surfaces are provided to alleviate this hazard.

ACOUSTICAL PROPERTIES

Another aspect to consider in the application of the translucent floor as an architectural finish and floor construction is the impact on the acoustical properties of the rooms and corridors in which it is placed. The tendency of adding a lot of hard surfaces like glass and concrete to a space is to increase the sound reflectance of the surfaces and consequently the reverberation time of the space. This outcome can be a

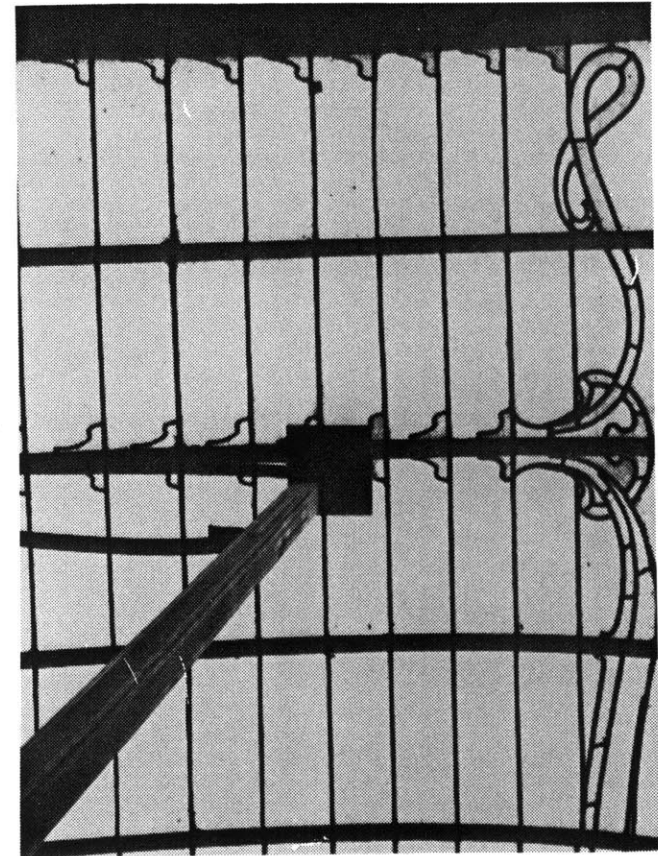

Fig. 77. An example of decorative translucency in the skylight which is now applicable to the floor.

problem if it severely affects speech intelligibility or acoustical privacy in the space. The degree to which translucent floor systems will do this is largely a result of their size and placement relative to the space they are in. In most cases the area of the translucent floor system is rarely more than half of the room size, allowing for more sound absorptive surfaces on the remaining portions of the room. In the case of spaces with larger ratios of translucent flooring, such as the school project in the next chapter, the addition of vertical sound absorbing panels at regular intervals throughout the space would be an effective way of reducing the problems associated with this condition. The application of these sound absorbing panels in appropriate places would also be effective in improving acoustical privacy between work stations in various open office settings.

The sound transmission coefficient (STC) of the translucent floor construction, is another aspect to consider in the evaluation of the acoustical properties of this application. In the case of the glass and concrete floor construction, the STC is not much worse than the thin concrete floor structure it replaces, however the elimination of the interstitial dead air space and the suspended acoustical ceiling treatment is significant and may lead to unacceptable STC values between some spaces. It should be noted, however, that in the spaces that require high levels of acoustical privacy it is also probably the case that the visual privacy issue of the

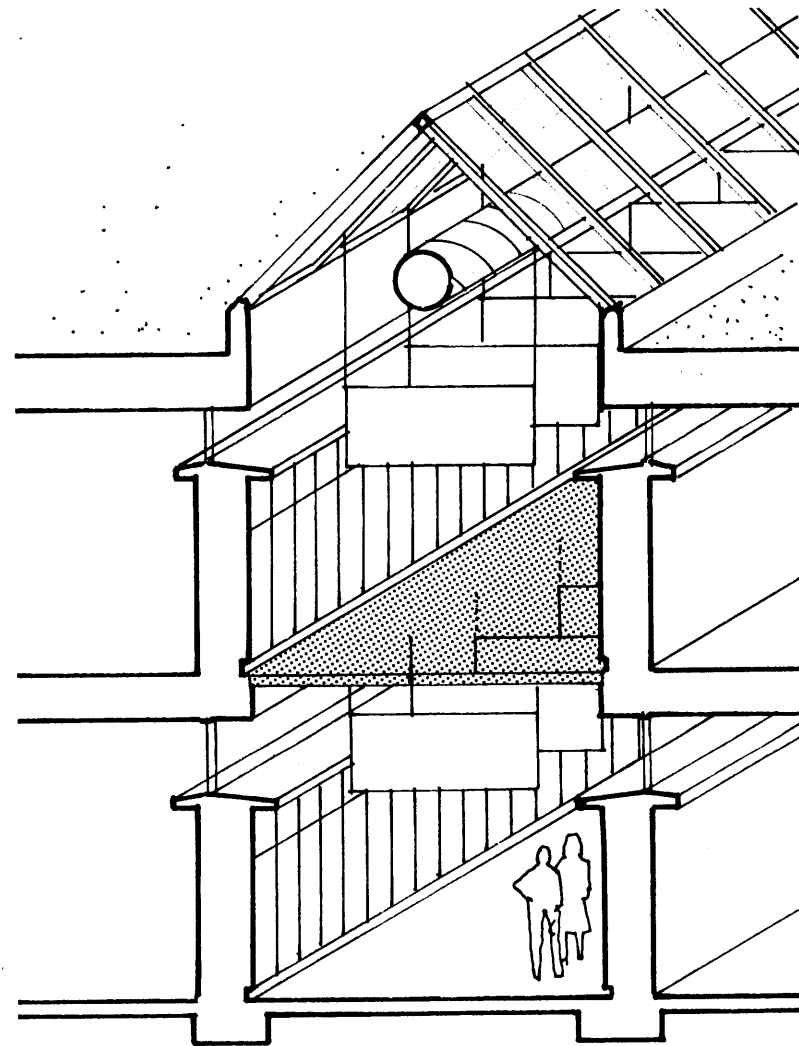

Fig. 78. Axonometric of Freeport Middle School luminous spine with the application of suspended sound absorbing panels to control excessive reverberation brought on by hard floor and ceiling surfaces.

translucent floor light would likewise eliminate it from consideration. The STC of the plate glass and steel floor light is somewhat worse than the more massive glass and concrete construction, but again, if the visual privacy and distraction considerations of the translucent floor are acceptable within a space then it is probably also the case that some loss in acoustical privacy is acceptable.

It should be kept in mind during this critique of the translucent floor that problems of acoustical privacy are common to all forms of shaft toplighting systems and are difficult to eliminate given the fact that sound and light behave in a similar fashion. This is to say that given a multistory toplighting scheme, whether open or closed shaft, a certain loss of acoustical privacy is to be expected. However, an important distinction is that the translucent floor offers somewhat better STC ratings than the open or glazed light shaft.

SOLAR GAIN AND THERMAL COMFORT

In chapter 2 during the discussion of clear sky conditions the potential thermal comfort implications of toplighting and horizontal openings were introduced. In order to provide adequate thermal comfort in the initial skylit room of the translucent floor daylighting system certain measures must be taken to control solar gain.

The degree to which this solar gain must be controlled depends on building type and location. Buildings which have significant internal heat gains and large core zones such as commercial and institutional buildings, require control of solar gain throughout most of the year. On the other hand, residential building types in temperate climates typically require solar control measures during the late Spring, Summer and early Fall. In any case, all building types require some solar shading during the cooling season. This is when the altitude of the sun and the horizontal orientation of the skylight tend to maximize the impact on thermal comfort of the skylit room.

There are a number of solar shading options available for this purpose. The oldest and most simple method of shading the skylight is the application of exterior louvers over the skylight. These louvers are oriented in such a way as to provide shade during the periods when solar gain is undesirable. This method is effective but not nearly as efficient as some of the more recent innovations. The more recent innovations in sun control incorporate the solar shading in the plane of the glazing itself. There are three sun control glazings which are in various stages of development and are applicable to the skylight in this case. The first method is the electro-optic glazing technology (ELO) which is presented in William Bartovics work on "The Thermal Performance of Fixed and Variable Transmitters in Commercial

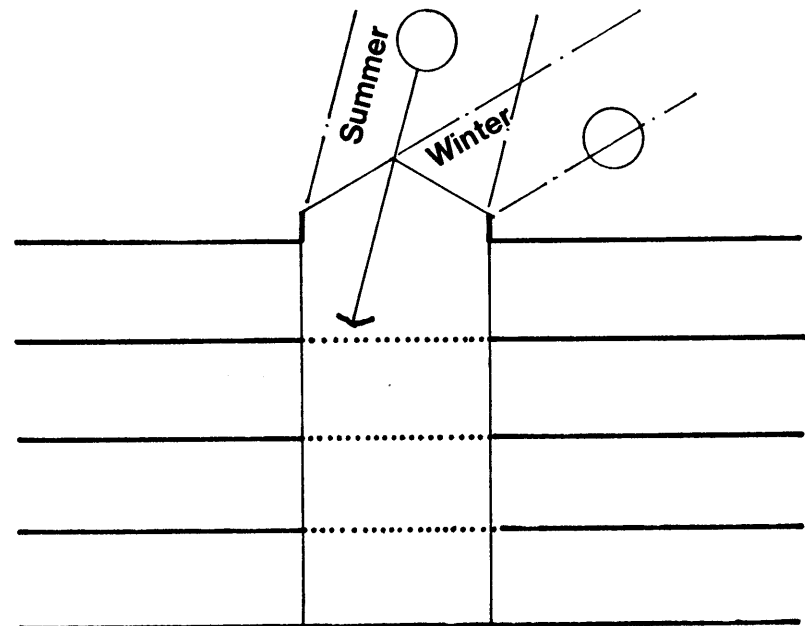

Fig. 79. Schematic building section diagramming the increased solar aperture and potential gain of horizontal openings during the cooling season.

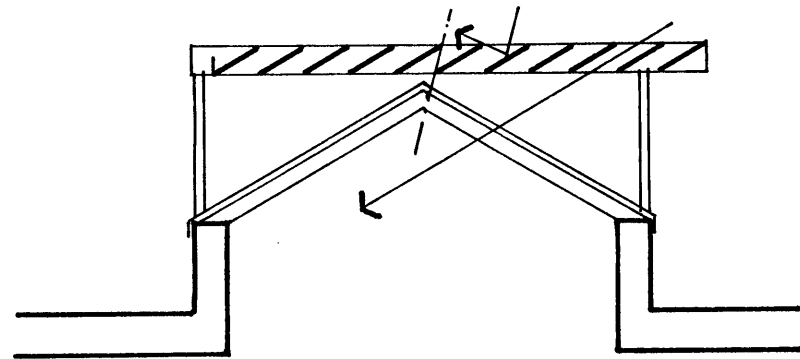

Fig. 80. Exterior shading louvers over skylight to control solar gain during cooling season.

Architecture." This glazing can be electronically switched to maximize or minimize solar gain without drastically affecting the visible daylight transmission. Electric fields are applied to the glass to affect the absorption of the heat content of the light (far-infrared) and prevent its penetration into the interior. When the electric fields are switched on the light transmission is in the range of 20%-30%. In contrast, when the fields are switched off the glass returns to a higher light transmission value in the range of 50%-60%.(15) The second type of sun control glazing utilizes a low emissivity coating on the interior of double-glazing to reflect out the the heat content of the daylight while allowing the transmission of the visible range of the spectrum. This glazing type currently marketed under the trade name of Gaurdian, has a fixed light transmission value of 65% while providing the necessary solar shading to preserve the thermal comfort on the interior. The third type of glazing employs narrow built-in louvers positioned and fixed between the glazings in double-glazed units. This method represents an integration and miniaturization of the external shading louvers presented in the beginning of this section. The orientation and spacing of these louvers is determined by the orientation of the skylight glazing and the latitude of the building location. The light transmission of this glazing type ranges from 50%-75% depending on the type of double-glazing in which it is incorporated.(16)

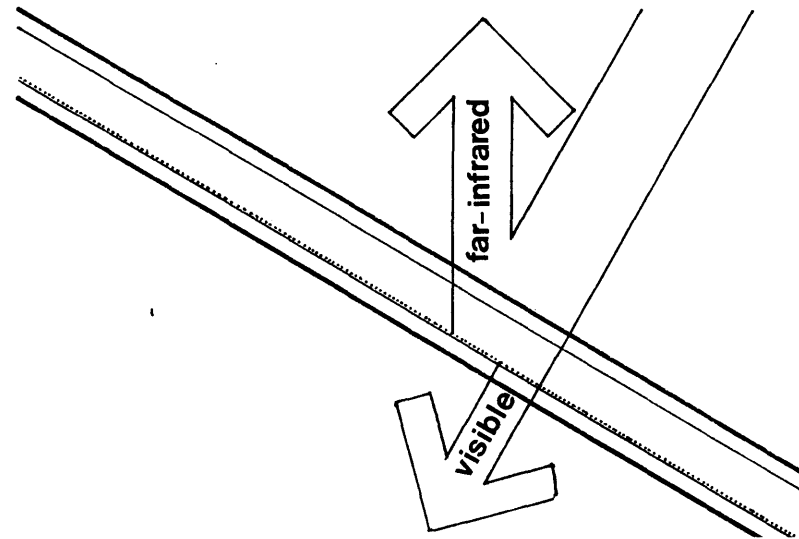

Fig. 81. Low emissivity coated Gaurdian Glass.

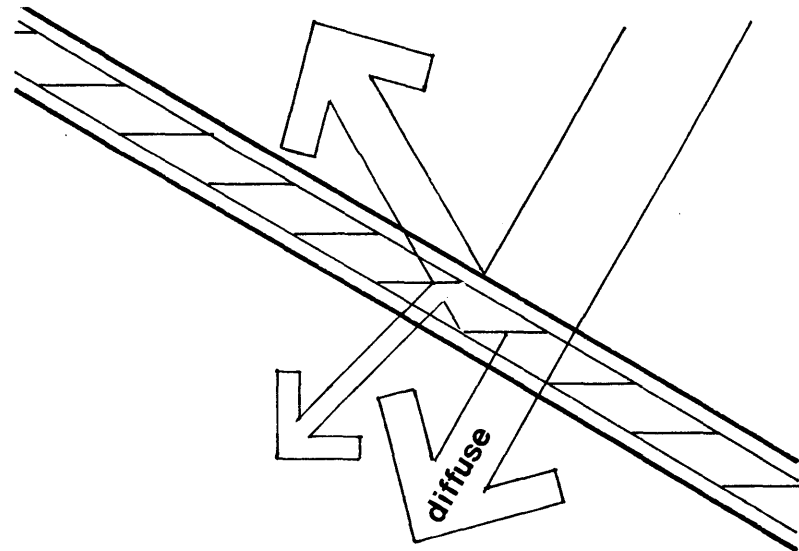

Fig. 82. Louvered glass at 30 degree slope.

Further discussion of the properties of these sun control glazings is beyond the scope of this thesis. This brief discussion will suffice for the purposes of addressing the shading requirements of the initial skylights employed in the translucent floor toplighting concept as a means of maintaining thermal comfort. Any of these sun control glazings are applicable to the initial skylight. For the purpose of comparison of the various translucent floor configurations throughout this thesis, a light transmission of 65% in the initial skylight was considered as representative of the employment of these sun control measures in the daylighting system.

CONCLUSIONS

This review of the various concepts of integration of the translucent floor system and the other systems associated with architecture has shown that in most cases integration requires the compromising of the maximum daylighting effectiveness to achieve the compound goals of the new system. An example of this type of compromise is present in the location of floor lights with respect to programmatic activities. In order to serve the combined function of floor and lighting systems, the location of the floor light shaft must seek out translucent zones within the building program rather than serve the space directly. However, in one distinct component, the floor light achieves the integration of structure, light, and finish. The architectural quality of

this accomplishment as well as some of the other advantages mentioned certainly outweigh the compromise in the quantity of daylight which is sometimes required.

In conclusion, as the architect seeks to integrate the translucent floor system into his or her architecture, the following recommendations should be considered:

1. As with the placement of any translucent material, either vertically or horizontally within the building, the requirements of visual privacy and degree of focus of the programmatic activities involved should be evaluated in the programming phase.
2. There is a clear compatibility between access or circulation space and translucency. Building reception and elevator lobbies, corridors and interwoven circulation paths within programmatic activities should be considered as prime locations for this type of daylighting system.
3. When constraints imposed by fire and life safety codes jeopardize the effectiveness of traditional open shaft daylighting systems, the application of the translucent floor should be evaluated as a possible resolution of this situation.
4. The decorative qualities of the translucent floor lens as a ceiling and floor finish can be employed to enhance the quality of a space in addition to quantitative daylight considerations.

5. The type of structural system employed in the translucent floor has a direct relationship on light transmission and fire resistance and should be selected on the basis of the requirements of these properties.

6. The initial skylight in the translucent floor daylighting system must employ sun control measures to preserve the thermal comfort of the skylit room or corridor during the cooling season.

In many architectural design situations generalized recommendations are of some use, but sometimes the most effective types of recommendations can be derived from specific architectural examples involving the application of the particular technology. The following chapter presents three prototypical examples of the application of the translucent floor system and can be used in addition to this chapter in deriving further recommendations regarding its application to architecture.

Chapter 6

ARCHITECTURAL PROTOTYPES

Beyond the recommendations and conclusions of the preceding chapters, there is no more convincing evidence of the successful application of the translucent floor system than the specific exercise of application per se. It is only in this way that quantitative assumptions and, most importantly, the qualitative implications in architectural design can be tested within the complex assembly of systems. The following three architectural prototypes cover a fairly wide range of building types: educational, commercial and residential. In each prototype I have explored an approach to the application of the translucent floor which is unique and, I believe, appropriate.

URBAN ROWHOUSES

The Urban Rowhouses is not a site specific-project, but rather a generic prototype which is characteristic of hundreds of specific rowhouse projects across this country and Europe. Although during the physical modeling of this application the prevailing sky conditions in the Boston area became the daylight standard, based on the graphs derived in chapter 3, the architect can adjust the particular translucent floor configuration to suit other daylight standards. There are two notable problems which make this building type an appropriate

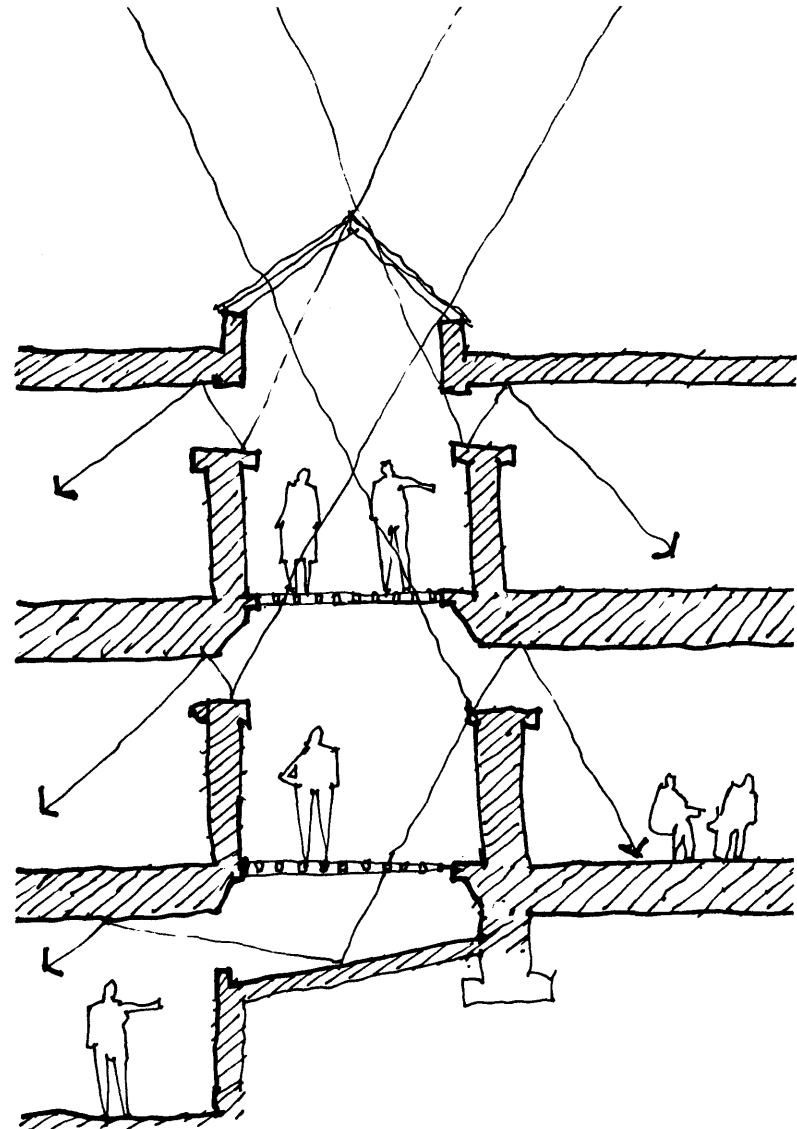

Fig. 83. Initial conceptual sketch of luminous spine in the Freeport Middle School.

candidate for the application of the translucent floor light. To begin with, the core portion of the traditional urban rowhouse suffers from a serious "gloom" or daylight deficiency in comparison to the side lit perimeter rooms which front on the limited perimeter of the unit. In addition, the pressing urban densities and land values which are characteristic of the sites in which this building type arise, make it difficult to provide a traditional ample light court to achieve this end.

This specific prototype involves a two bedroom rowhouse unit of 1280 GSF with an optional full basement. A series of eight units are depicted on a straight street frontage, but the number of units and overall size is mainly a function of shape and extent of the street frontage. A feature which is typical of most rowhouse building plans is the load bearing party wall separating each individual unit for reasons of fire separation and privacy. Given the beneficial "wall effect" of the translucent floor system and the efficient placement of circulation adjacent to one wall or the other, these concepts began to suggest the creation of a stair well and hall light shaft. The light shaft begins with an initial skylight adjacent to the party wall and continues down with the placement of translucent flooring in the hall, overlapping into the bedrooms at either end of the second floor.

During the physical daylight modeling, the concept for this daylighting configuration was explored in a related model.

The testing involved in the development of the "light between the wall" relationships established a known daylight factor profile and average value which can be applied to this and other related building configurations as long as some of the slight differences are correlated to the original configuration. The important consideration to note is the direction, whether increasing or decreasing the daylight factor, of the modification to the original model. This consideration is based on the assumption that, in attempting to estimate "sufficient" core brightening based on related modeling, it is better to achieve increases in daylight factors with respect to the original model, than to estimate the results of decreases and risk falling below the standard of "sufficient". In this case the modification to the original model configuration involved an increase in the transmission value by adding the stair well opening and an enlargement of the overall floor light and well opening. Based on the graphs and relationships developed in chapter 3, it is possible to roughly approximate the change in daylight factors resulting from these modifications. The graph of the approximation of the resultant daylight factors is plotted over the building sections in figure 87 with the scale off to the left hand side of the sections.

The brightening of the core zone diagrammed in building section AA can now be shared by the rest of the spaces to create balanced bilateral daylighting in the perimeter rooms

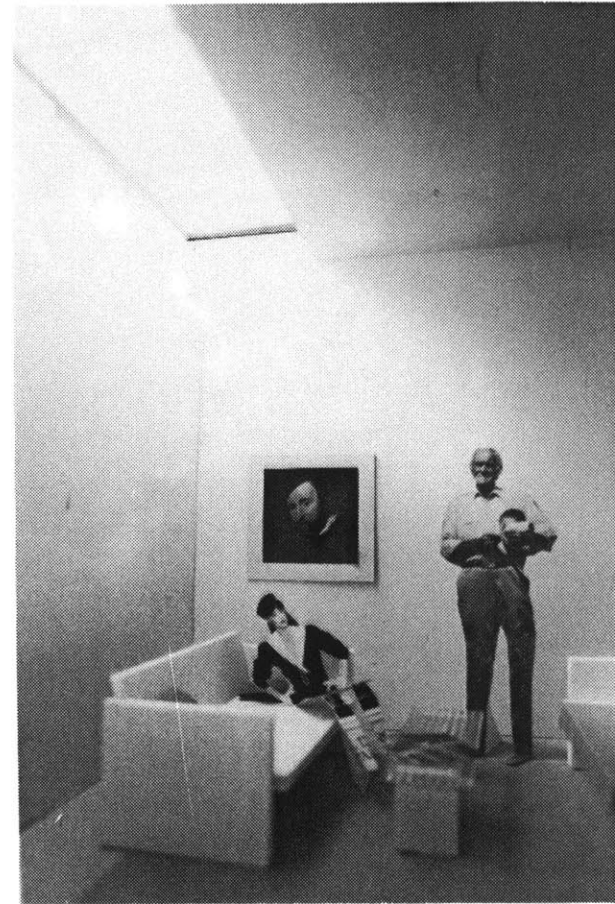

Fig. 84. View of the initial rowhouse light model with the floor light as a continuous 3'-0" strip across the back of the living room.

and, with the exception of some dark corners, to eliminate the core "gloom" which was characteristic of the traditional urban rowhouse. A close analysis of the profile of this graph confirms that the distribution of daylight in the core zone is now nearly within a factor of two of the perimeter levels which marginally achieves the qualitative standards established in chapter 3; a more technical way of describing the elimination of "gloom". The spread of daylight across the unit in the transverse direction, however, is still excessively varied with the back of the kitchen somewhat darker than the passage between the front and back of the unit. A light shelf located in the pass through to the kitchen would be one alternative to consider in lessening this condition. Another possibility would be to push the header over this opening up into the rest of the floor construction, thus enlarging the wall opening and better utilizing the ceiling cavity.

The absolute daylight factors throughout the first floor plan are in excess of the minimum 1% daylight factor standard established in chapter 3 for dwellings. In climates where the standard is in the range of 2-3 %, however, somewhat larger floor light apertures and larger interior wall openings would be required to provide sufficient core daylighting employing this concept. In addition, the daylight factors represented in this graph are based on an initial skylight transmission of 65%, which assumes the use of a low emmissivity glass and

some dirt depreciation. In climates where glare control is less essential or other types of glare control are used, this value may be as high as 75%, resulting in a commensurate increase in daylight factors.

In general, the application of translucent floor toplighting in this situation is most effective at balancing the daylight levels in conjunction with traditional side lighting, rather than providing completely sufficient daylight levels to the core alone. Based on the architectural integration issues presented in chapter 5, the translucent floor, in this case, is placed at a point in the core of the plan which takes advantage of the required stair well and the relatively high translucency of the circulation zone. This practical integration, although required by the nature of the translucent floor, may represent some distribution tradeoffs when compared with the initial "light between the walls" daylight model.

In terms of the formal architectural quality of this application, the highlighting of the linear circulation passage between the front and the back of the unit with the luminous glow of the ceiling achieves a clear expression of the organization of the the unit and the hierarchy of spaces. The view upon entering the unit, looking down the hall, shows the luminous ceiling at once containing the horizontal continuity of the passage while at the same time hinting of the space and light above. Only the unique integration of the translucent

floor can achieve this authentic joining of surface and light in one component.

The combination of side lights or windows and floor lights is applied in the optional basement spaces associated with this rowhouse building type. In lieu of the troublesome and marginally effective exterior window well, floor lights are placed near the foot of the perimeter windows to borrow light to the basement space below. This application, in conjunction with some floor lighting at the core zone, results in sufficient daylight factors for typical basement functions. As is typical with the translucent floor, the distribution of daylight, through successive passes of diffusion and interreflection, is relatively even and glare free.

These are by no means the only ways to apply the floor light to residential design. However, this method is uniformly applicable to the planning conditions which are representative of the urban rowhouse. The concept of introducing light between the walls as bilateral daylighting in a large room is suggested in the initial daylight model. In addition, when applied in conjunction with other floor openings and the translucency of circulation, as explicitly presented in these drawings, either approach can be effective in improving the quality and quantity of light in the urban rowhouse.

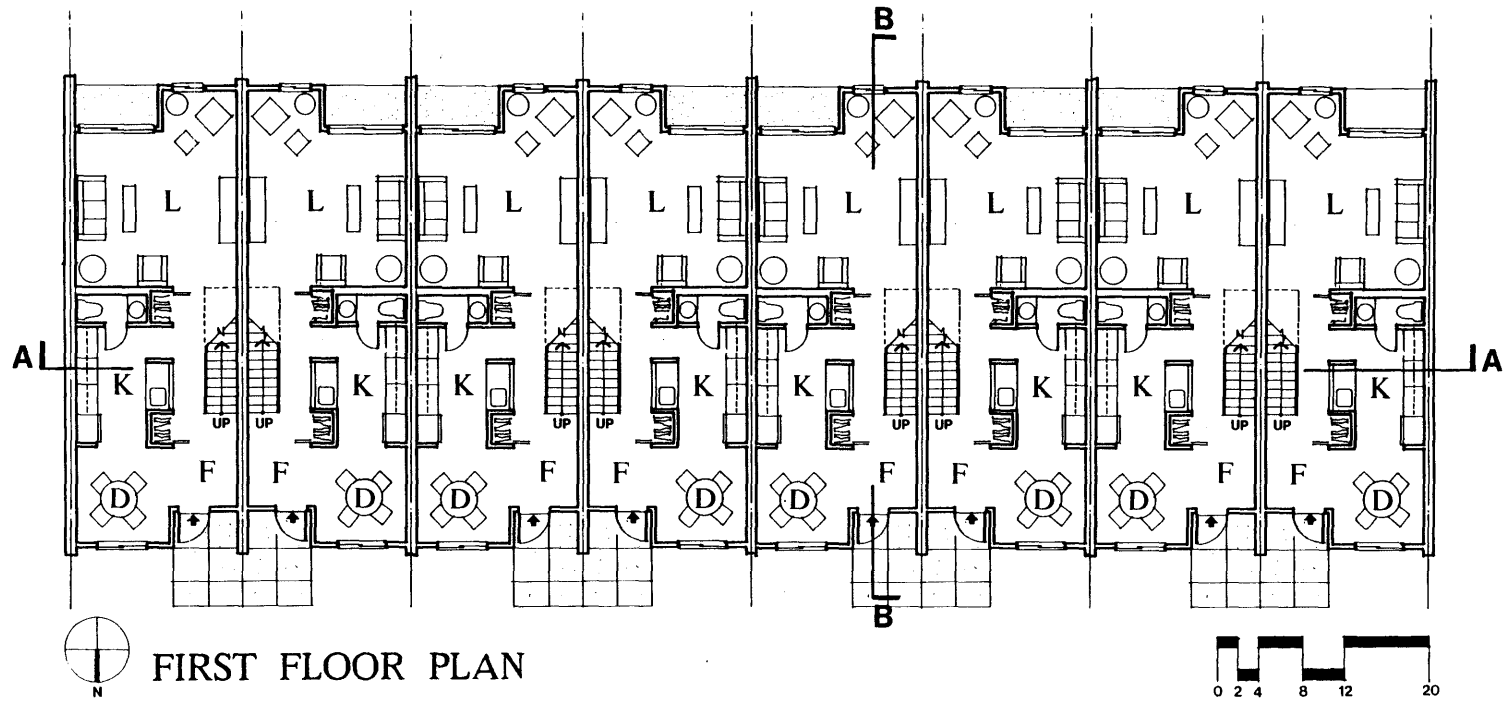

Fig. 85 First Floor Plan, Urban Rowhouses, site unspecified. KEY: L.livingroom K.kitchen F.foyer D.diningroom Optional floorlighting to Basement not indicated in Plan. See Building Sections.

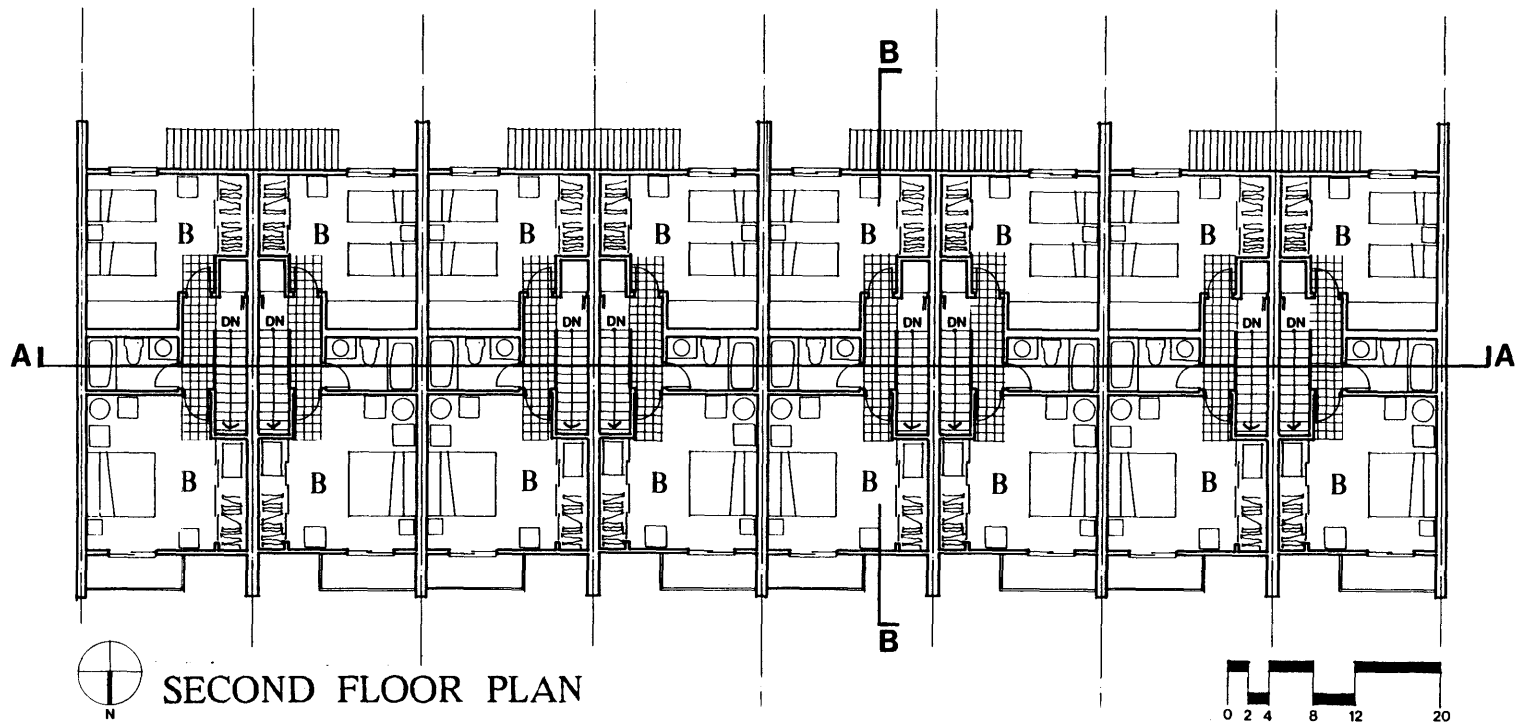
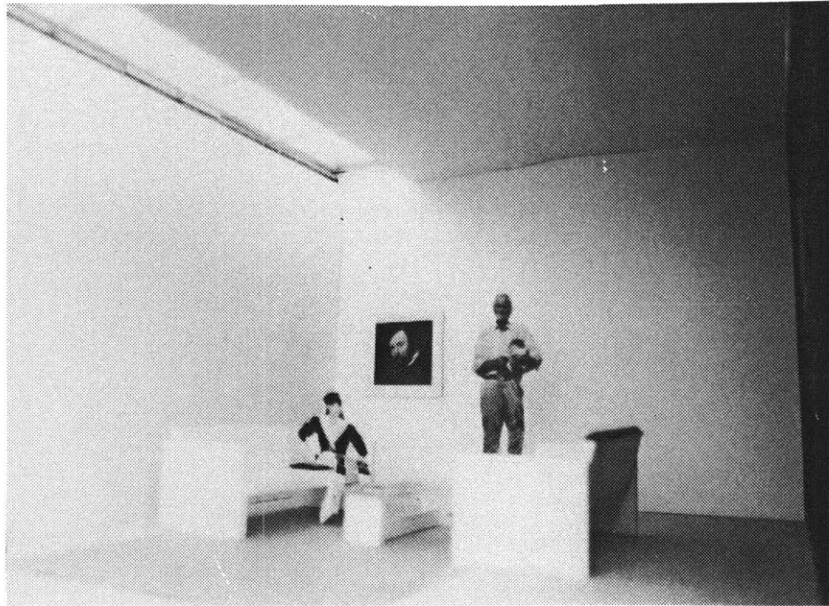
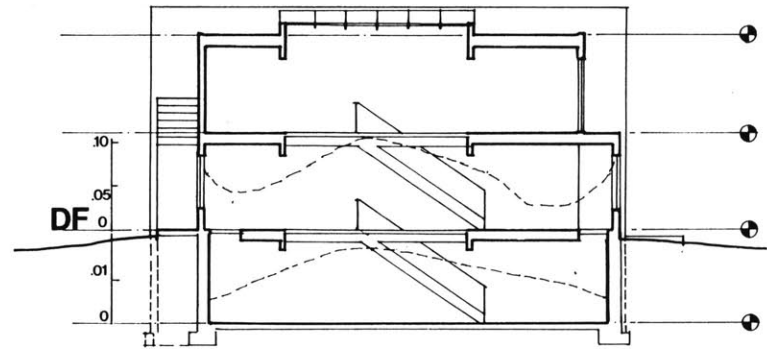

Fig. 86 Second floor plan, Urban Rowhouses, site unspecified. KEY: B.bedroom Grided portion of Floor denotes area of translucent floor.



MODEL



BUILDING SECTION BB

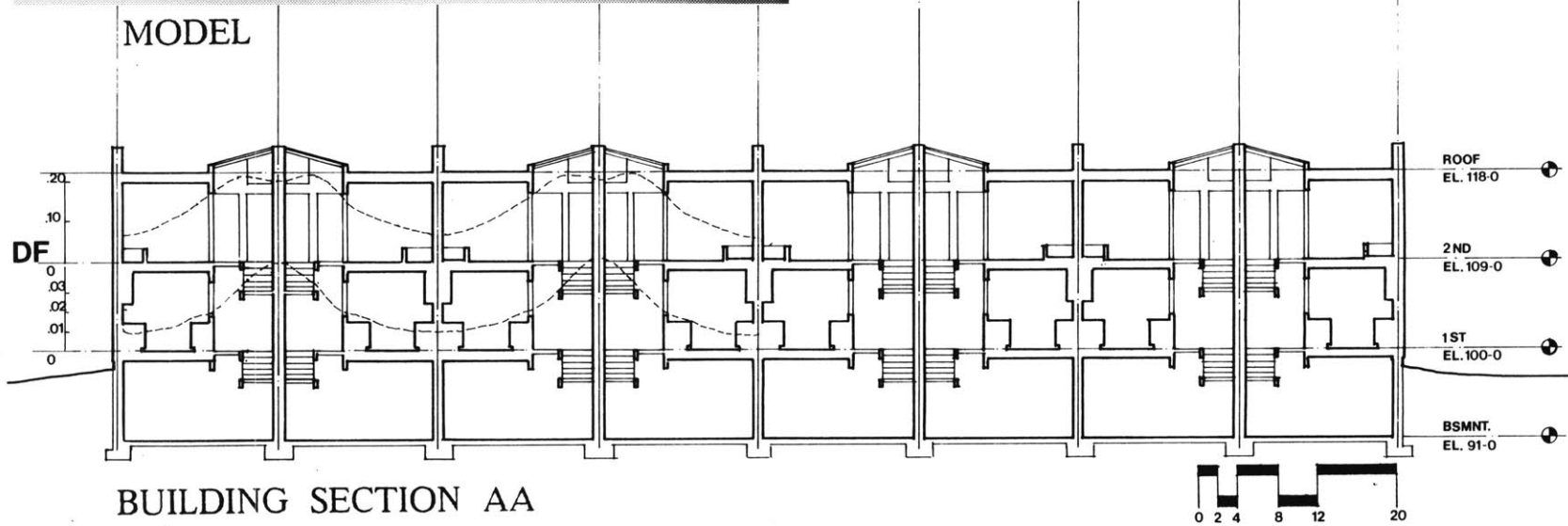

BUILDING SECTION AA

Fig. 87 Building Section AA, Building Section BB and Model, Urban Rowhouses, site unspecified. Dashed line overlay and left hand scale indicate daylight factor profile.

LOWRISE COMMERCIAL OFFICE BUILDING

The lowrise commercial office represented in this example is also not a site-specific building plan, but again, represents a schematic prototype for the application of the translucent floor system in this building type. It should be noted in the presentation of this prototype that, although most of the references are to low-rise applications, the principles apply equally to mid-rise applications up to three or four stories given larger floor light openings. In reading these plans and sections for this purpose, the second floor plan would become a typical plan and the section would reflect the additional number of floors in a similar fashion to the low-rise application depicted.

The form of the commercial office building is generated by a number of overlapping programmatic considerations. Like the urban rowhouse building type, it arises from the external pressures of growing urban and suburban densities and rising land values. The internal forces of building economics and their relationship to allowable gross to net floor area ratios and efficient building volumes and envelopes tend to favor compact massing schemes. The principal characteristic of this tendency with respect to perimeter daylighting is the development of large core zones in proportion to the perimeter area. The requirements for artificial lighting in this proportionally large core zone leads to that sector of energy usage in the building becoming the dominant load. It is ironic that this building type with its' primary service during the daylight

hours must generate a dominant artificial lighting energy load.

The commercial office building type is another good candidate for the application of the translucent floor system because of these overlapping considerations of density, economics and lighting. The concept applied in this prototype derives its rationale from the compatibility of established circulation patterns to floor translucency within a general office plan. It utilizes a tree-like cantilevered structural system combined with other utilities to support and service the space on each platform. The series of platforms is carried up on a single central column to the final roof canopy, where the initial skylight replaces the floor light grid. This prototype represents an especially effective integration of the overall building structural schematic and the overlapping grid of translucent floor daylighting. The single, central support column of each platform and the tapering of the platform itself up to the floor light grid provides an ideal profile for the shadowless wash of daylight across the ceiling of each platform. During possible night use, auxiliary artificial lighting placed at the stem of each platform would utilize this splayed ceiling from the opposite direction.

This specific prototype was modeled using a plate glass translucent floor system in attempt to raise the light transmission value and consequently reduce the translucent floor grid area. It is possible to use either of the

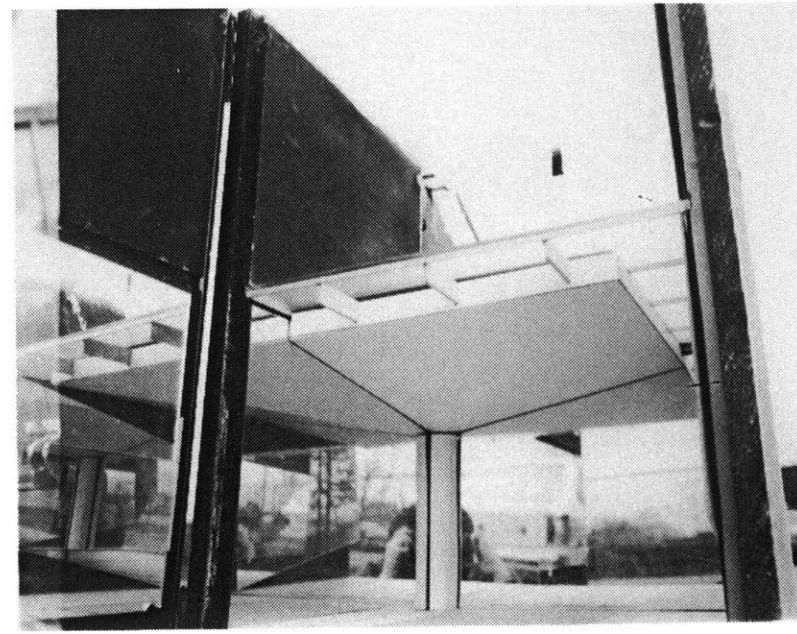

Fig. 88 The physical daylight model of a typical structural bay of the commercial office prototype.

translucent floor systems in this case, but each system has its inherent advantages and disadvantages. The plate glass and steel system provides higher light transmission and smaller area, while it does not offer the required fire resistance for mid-rise application. On the other hand, the glass and concrete system offers this fire resistance but at a premium of light transmission and required floor area. The formal architectural quality of this prototype can be likened to working in a forest of trees with the daylight filtering down from between the canopies creating a pleasant ambient light quality. In addition, the relationship of opaque and translucent or solid and void follows a pattern consistent and in harmony with the structure and form of the architecture.

Although this commercial office prototype is limited in presentation to one specific building dimension, the translucent floor and structural system which it utilizes can be expanded indefinitely in either horizontal dimension and in unlimited configurations within the constraints imposed by other building considerations. Likewise, as stated earlier, it may also be extended vertically up to three or four stories given larger translucent floor areas.

A daylight model of a typical structural bay in this lowrise application was modeled in order to graph the daylight factor profile of the first and second floors. This graph is plotted over the building section AA as a light dashed line

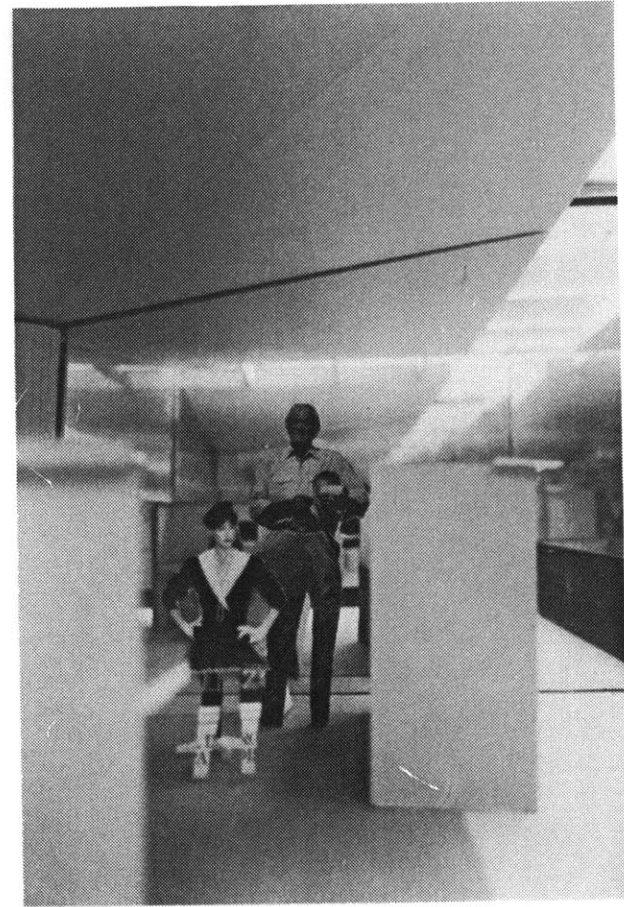

Fig. 89 A typical work station in the commercial office prototype with daylight filtering down from between the canopies.

and depicts the daylight profile across this portion of the building. The daylight quality, observed in this model is glare free, but the distribution tends to be rather uneven with locations within the plan having daylight factors which differ in excess of two. The daylight factor standard established in chapter 3 set the minimum factor for the ambient office environment at 2%, considering the employment of some task lighting in the immediate vicinity of the work station. The daylight factors which resulted from the observations of this model confirmed the quantity of daylight to be marginally sufficient for the ambient general office environment. A close analysis of the profile of this graph shows that work stations from midway between the central column and circulation grid on out receive sufficient daylight for much of the task work as well. According to the standard established in chapter 3, this level would be in the range of a 3% daylight factor. Although daylight factors do fall to a sub-standard level (below 2% daylight factor) in the vicinity of the central column, the placement of furniture assures that work stations will be spaced such that few will suffer this minimum value. A quick analysis of the area of the core which falls within this substandard daylighting zone confirms that it is a relatively small area, on the order of 14%, in comparison to the 86% of the first floor which is in the 2% - 5% daylight factor range. When this portion is compared to the total area of the core on both floors, it represents only 7% of the area. Although

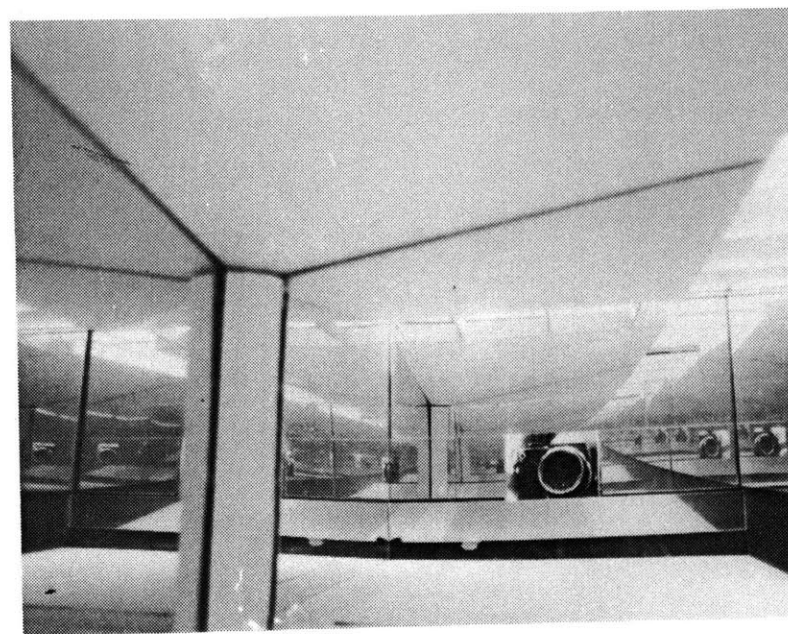

Fig. 90 A typical structural bay.

these dark spots in the plan in addition to the light distribution issue represent some remaining problems with this concept, the overall results of the modeling confirm this prototype to be relatively successful.

During the physical modeling of this project, two different light shelf alternatives were explored in an attempt to redirect some of the daylight from the immediate vicinity of the underside of the translucent floor up onto the ceiling structure. It was thought that these measures could alleviate some of the unevenness of light distribution which the open model exhibited. The first option employed a 2'-0" wide mirror canted toward the ceiling surface. Although this option did tend to brighten the ceiling surface, it also obstructed the line of sight from the work station to the the underside of the floor light. This effect resulted in an overall drop in the daylight factors across the plan. The second alternative for the light shelf explored the use of a partially reflective material which would allow some of the light to pass through along the initial line of sight. This material was modeled as a plastic film with a light transmission of 50%. Although there was some improvement over the mirror, this measure continued to decrease the the daylight factors across the plan. In both cases the light shelf was positioned at a height of 7'-0" off the floor and along the edge of the floor light.

The addition of light shelves for redistribution of light in the open office landscape organization thus proves to be less effective in this location than the provision of a line of sight to the floor light. There is a third alternative, however, which is more of a reflective canopy than a light shelf and is positioned such that it does not obstruct the line of sight between the work stations and the floor light. The placement of a reflective glass gable would reflect up to the ceiling much of the excess of daylight which otherwise would fall on the circulation path. Being semi-transparent, on the order of 50% transmission, it would allow a sufficient amount of light to pass through to either continue to the next level down or illuminate the circulation path. This excess of daylight which is now washed across the ceiling can serve to alleviate the distribution problem as well as to eliminate the sub-standard values around the center columns. The one possible side effect of this semi-reflective canopy would be the development of glare conditions within view of the reflective portion of the canopy surface. Unfortunately, the limitations in scope and time of this thesis did not allow for the adequate testing of this concept. However, in theory it poses a possible resolution of the light distribution deficiencies related to the open model discussed earlier.

The translucent floor system in this prototype offers to put the daylight back in the office environment even under the

constraints of density and building economics. Although the occupants of the core zones in this building type are still without the amenities of a window and view, they need no longer be deprived of the visual quality which daylight offers the interior environment.

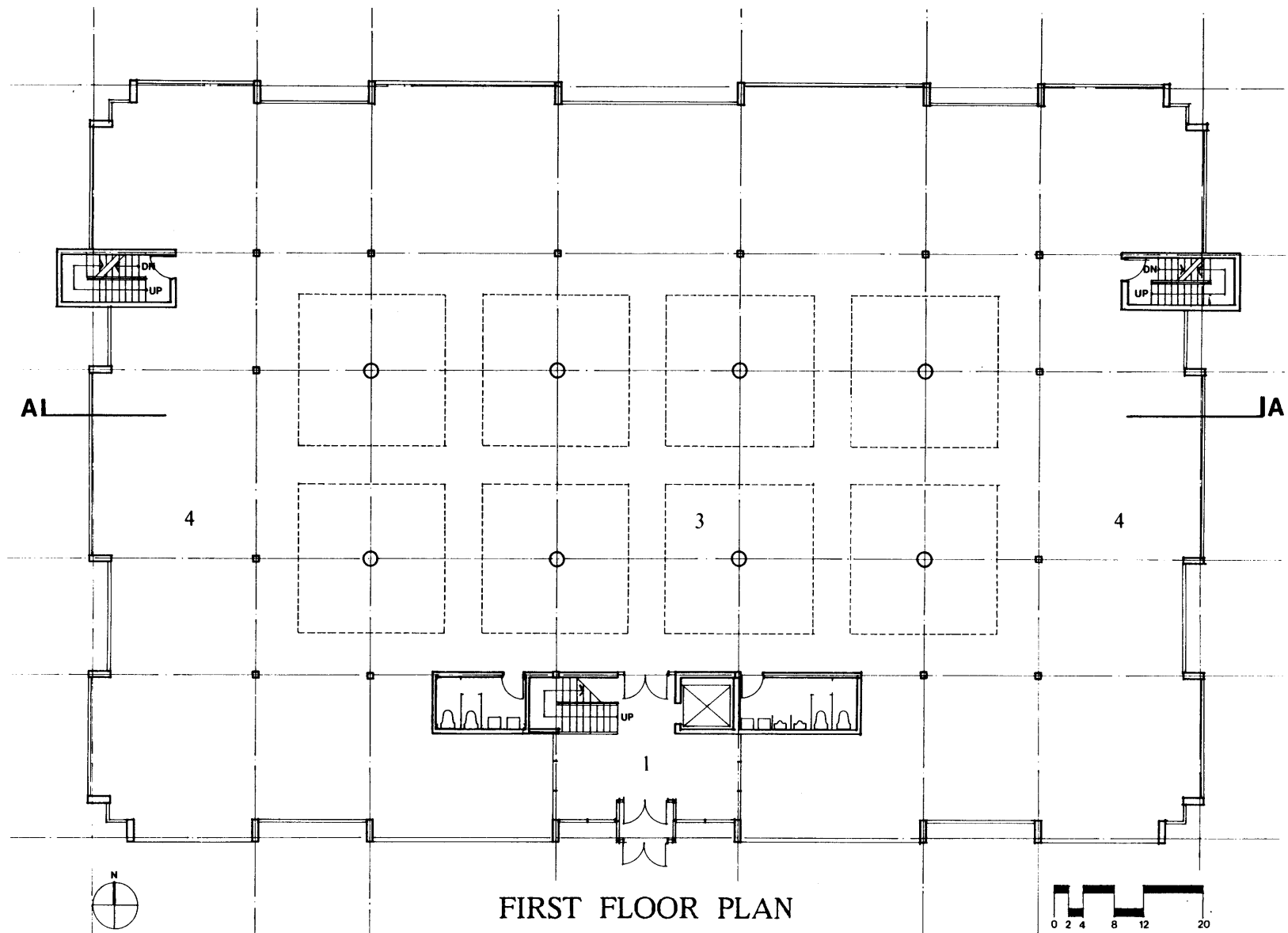
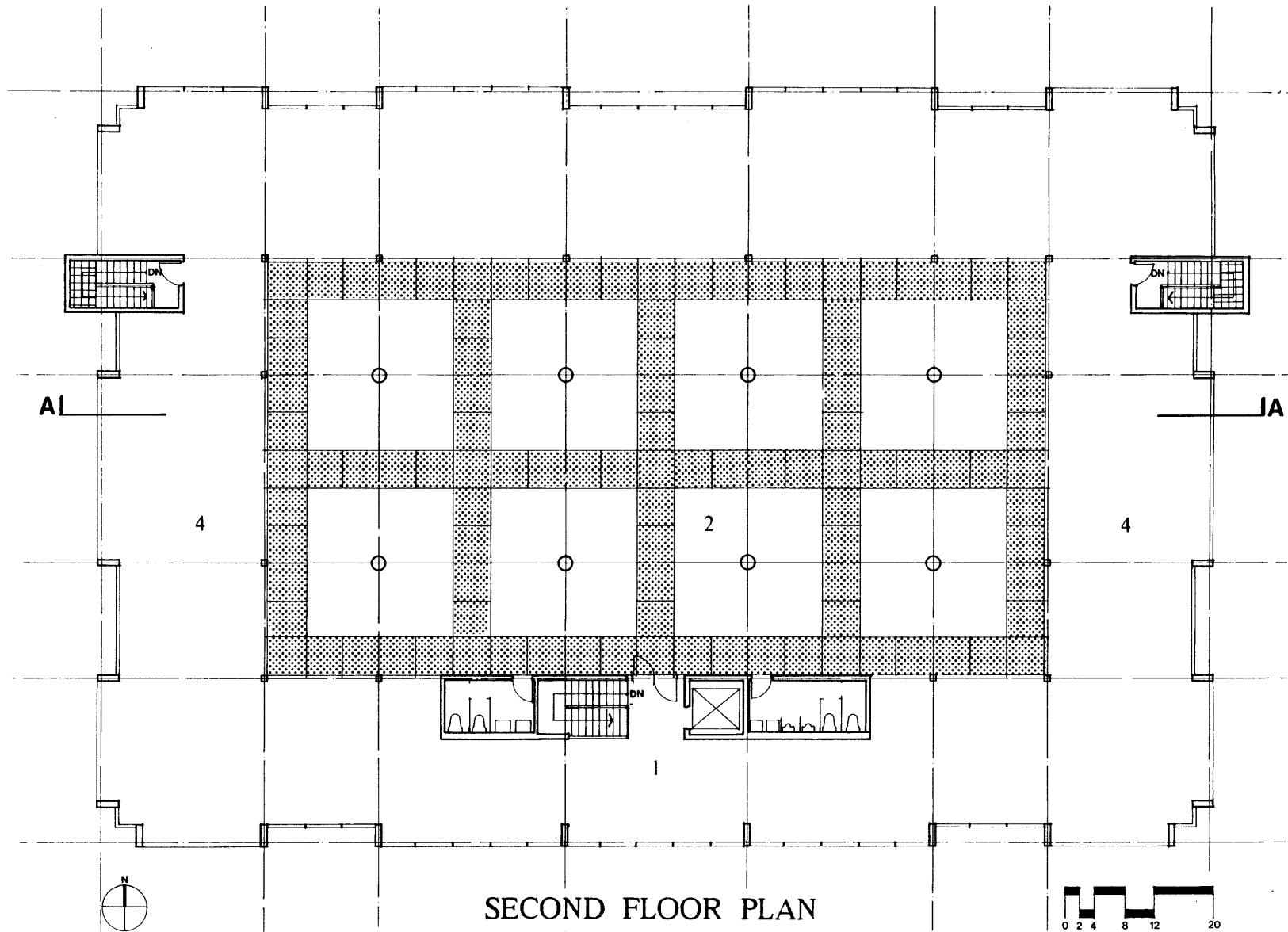

Fig. 91 First Floor Plan, Lowrise Commercial Office Building, site unspecified. KEY: 1.Reception lobby 2.General office 3. General office and research library 4.Executive offices and conference rooms (partitions and furniture not shown.)



SECOND FLOOR PLAN

Fig. 92 Second Floor Plan, Lowrise Commercial Office Building, site unspecified. KEY: 1.Reception lobby 2. General office 4. Executive offices and conference rooms. (partition and furniture not shown, shaded portion of floor denotes areas of translucent flooring.)

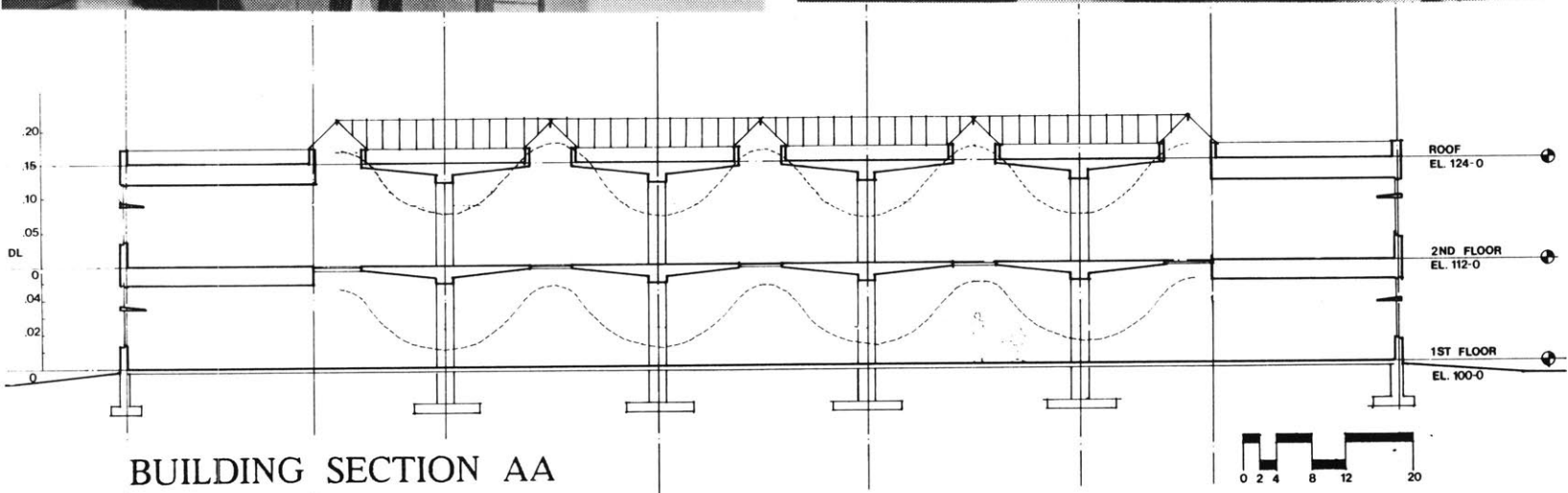
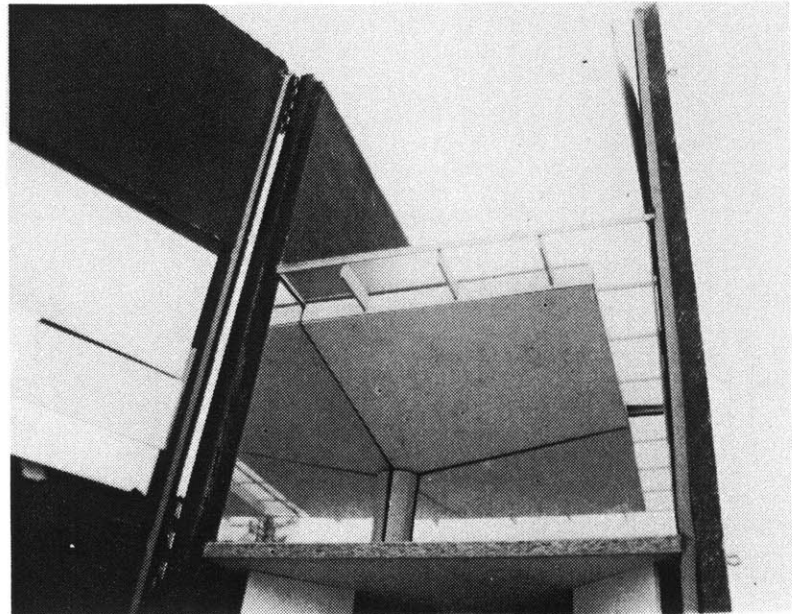

Fig. 93 Building section AA, model of typical work station and structural bay, Lowrise Commercial Office Building, site unspecified. Dashed line overlay and left hand scale denotes Daylight factor profile of building.

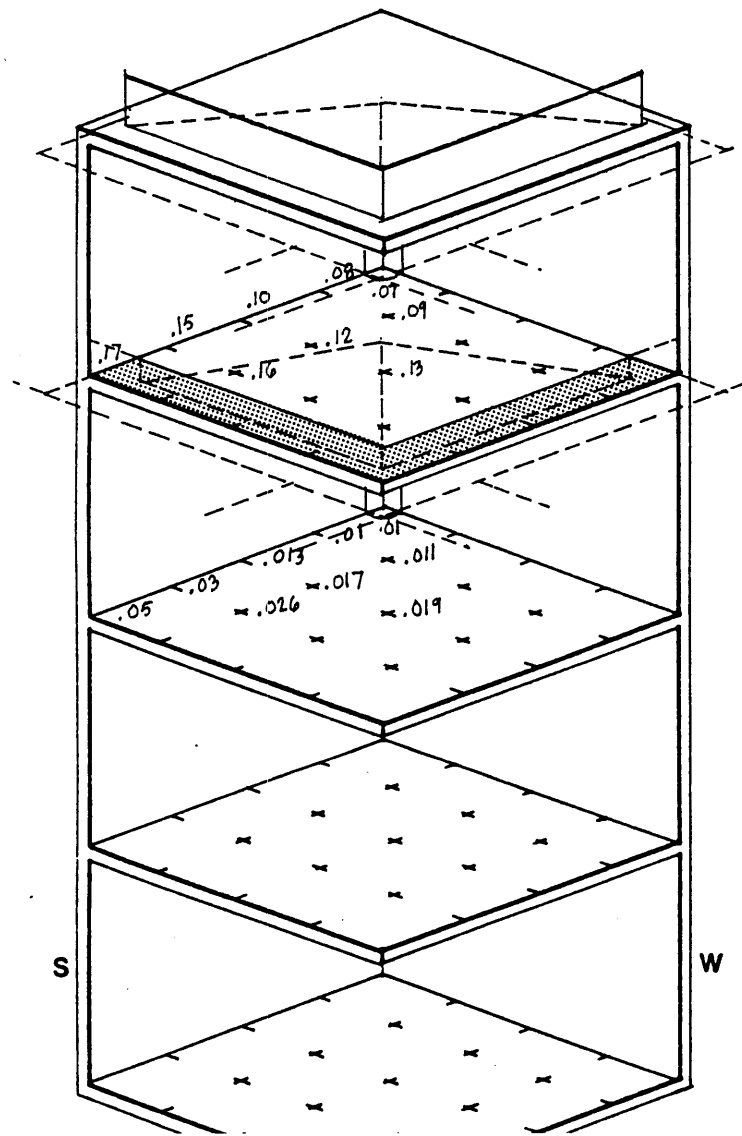

Fig. 94 Isometric diagram of daylight model showing resultant daylight factors with beige floor finish (reflectance of 45%).

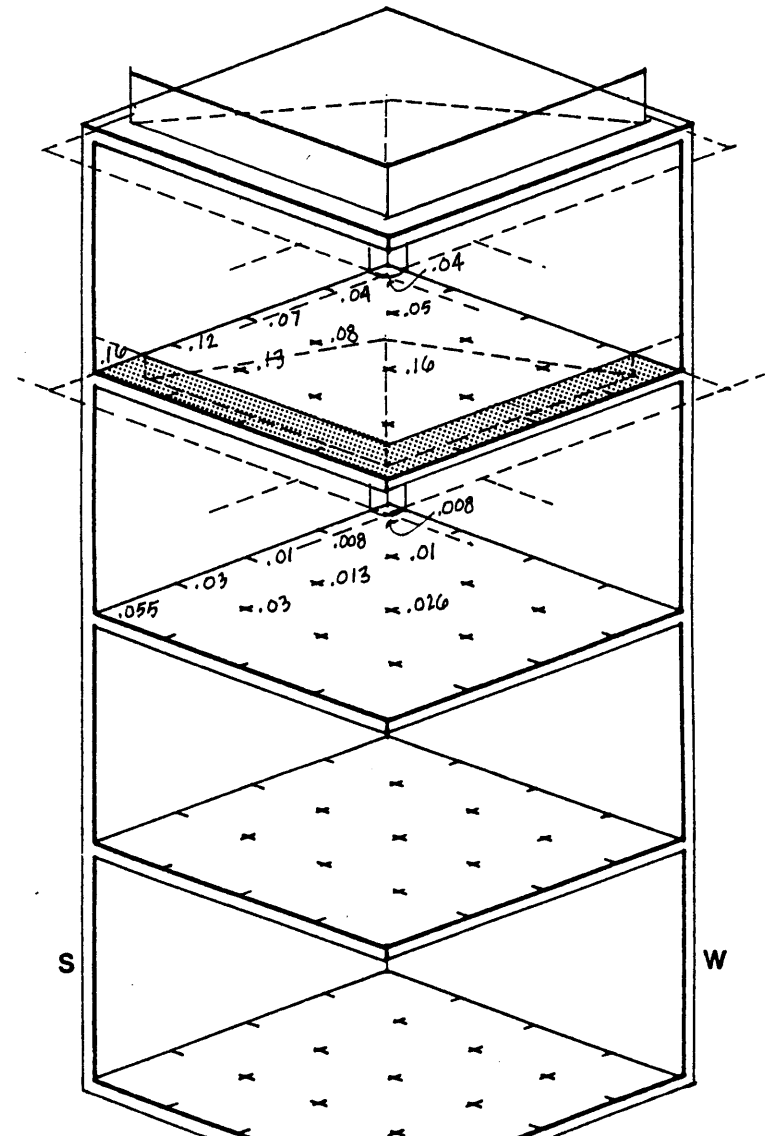

Fig. 95 Isometric diagram of daylight model showing resultant daylight factors from addition of white floor finish (reflectance of 80%).

FREEPORT MIDDLE SCHOOL

The Freeport Middle School is the only site specific prototype of these three examples. The project is located in Freeport, Maine, in the east central portion of the state just south of 44 degrees north latitude. The climate is typically maritime, with a relatively high percentage of overcast days. This condition, in addition to the time of year of the school calendar, gave rise to one of the primary considerations in the daylighting design, which was the selection of a 500 fc ambient daylight standard. This standard established a minimum daylight factor within the classrooms of 7% in order to maintain a minimum of 35 fc at the working plane throughout the school day and year.

The architectural program in condensed terms consisted of a new school building for a student body of 300 students, a classroom cluster for each grade level, 7th through 9th, contained three general classrooms and a science classroom. In addition, the common functions of Administration, Arts and Crafts, Industrial Arts, Special Education, Home Economics, Library, Cafeteria, Music Room, Gymnasium and locker rooms filled out the building program.

As a school building, the architectural program included a highly regular class schedule which regulated occupancy in various parts of the building with respect to time. This aspect of the program assured a relatively high translucency of the corridor during the class sessions and promoted the dual purpose of the corridor space.

The underlying architectural concept in the organization of the plan centered around the creation of a double loaded thermal and luminous circulation spine on the two main levels of the school. This circulation spine threads through the middle of the classroom clusters and the common program spaces tying the whole building together. The luminous circulation spine, capped by a continuous louvered skylight and paved entirely in translucent flooring on the second floor and partially on the first floor serves to illuminate the core of the building and offer even bilateral daylighting to the classrooms as well as other spaces along its length. The luminous spine offers daylight to the lower level locker rooms through large light wells placed beneath the translucent corridor as it passes over these spaces. A highly reflective finish on the interior of these wells funnels the light towards a large transom which serves these spaces directly. The transmission of daylight from the corridor to the classroom spaces is achieved through large transoms over the doors and lockers lining both sides of the corridor. As was investigated in more detail in the chapter on modeling,

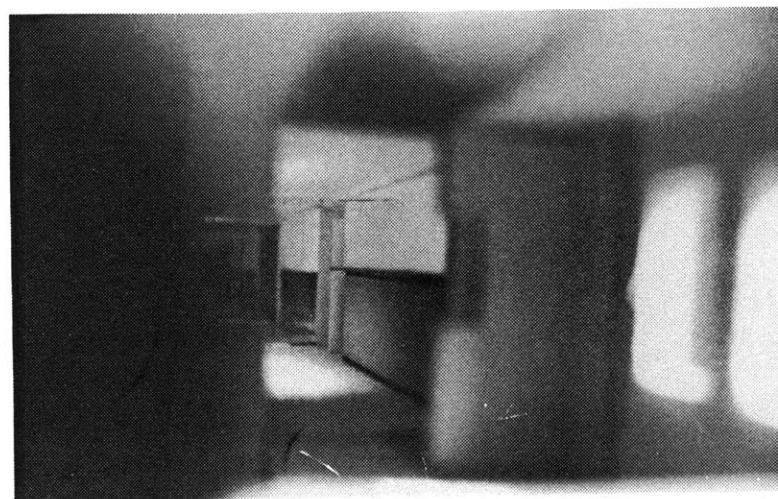

Fig. 96. A view looking down the luminous spine (corridor).

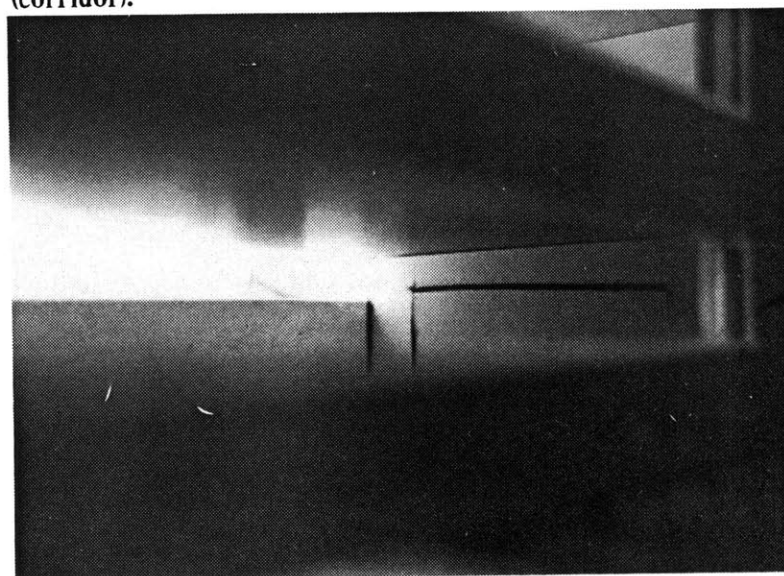

Fig. 97. A view looking across the locker room towards the light well and transom.

a large light shelf forms the sill to this transom and helps to spread the light deeper into the back of the classroom. The semi-glossy surfaces on the student lockers lining both sides of the corridor are effective in "funneling" the daylight down to the corridor and spaces below, also discussed in chapter 3.

The two most effective aspects of the application of translucent floor lights in this project are:

1. The compatibility of translucency in the corridor to building scheduling as discussed in the last chapter.
2. The integration of the programmatic efficiency of the double loaded corridor and the daylighting potential of the luminous spine.

In the physical modeling procedure for this project, one full classroom cluster was constructed at a scale of 1/4"=1'-0" to attempt to quantify and qualify the daylight profile. The daylight factors which resulted from this model are graphed over building section BB and in a partial plan of the classroom cluster (fig.98). Unlike the modeling in the other projects, this model included the effect of perimeter windows in the daylight factors across the plan, and consequently it is difficult to isolate the individual effect of the translucent floor system. However, the larger scale modeling of this concept in chapter 3 does consider the effect of the

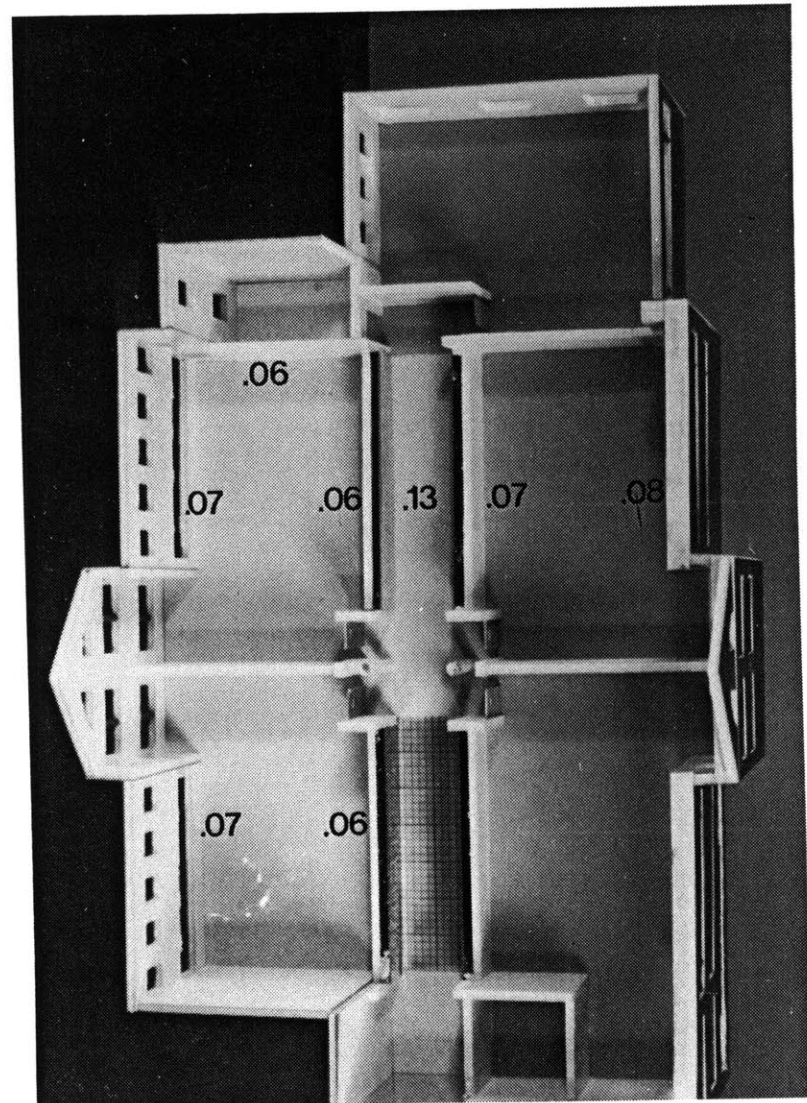

Fig. 98. A typical first floor classroom cluster model plan view with daylight factors shown in several key locations.

translucent floor alone. These values can be used to understand the contribution of the luminous spine in the modeling of the cluster. Nevertheless, this application is only suggested to achieve balanced bilateral daylighting in conjunction with perimeter windows and not as the sole source of daylight in the building.

A review of the daylight factor profile across building section BB shows that the contribution of the luminous spine is effective in balancing the distribution of daylight across the classroom. The values at the back wall of the classroom are certainly within a factor of two of the perimeter and the overall levels throughout the plan are very close to the standard minimum daylight factor of 7% established earlier in this section.

The actual configurations of the light shelf along both sides of the corridor were not modeled in the smaller cluster construction. However, given the results of the larger model tests, some modification of these light shelves would result in even higher classroom daylight factors. A review of these configurations suggests that a mirrored surface inclined towards the receiving room would tend to be the most effective quantitatively. On the other hand, the qualitative issues of glare must be kept in mind when using specular reflectors. Fortunately, no direct sun ever reaches these light shelves and a visual inspection confirms that the use of this type of surface does not pose serious glare problems.

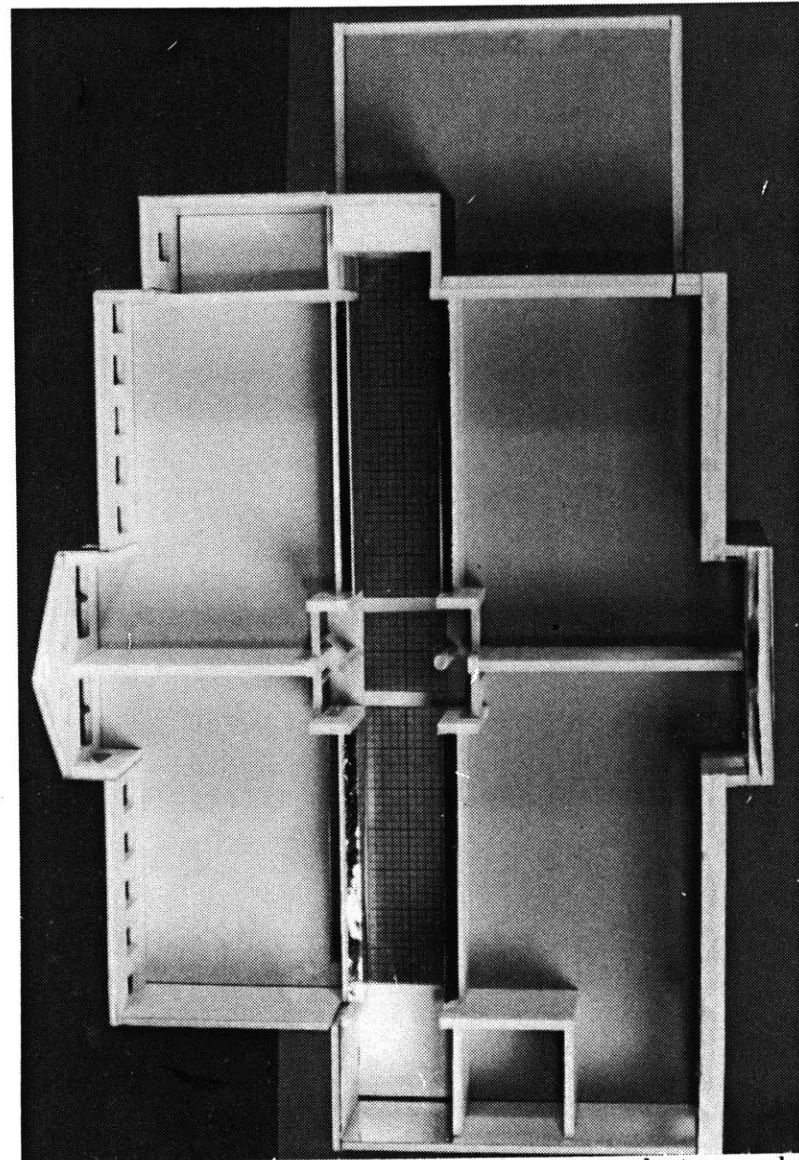

Fig. 99. A typical second floor classroom cluster model plan view.

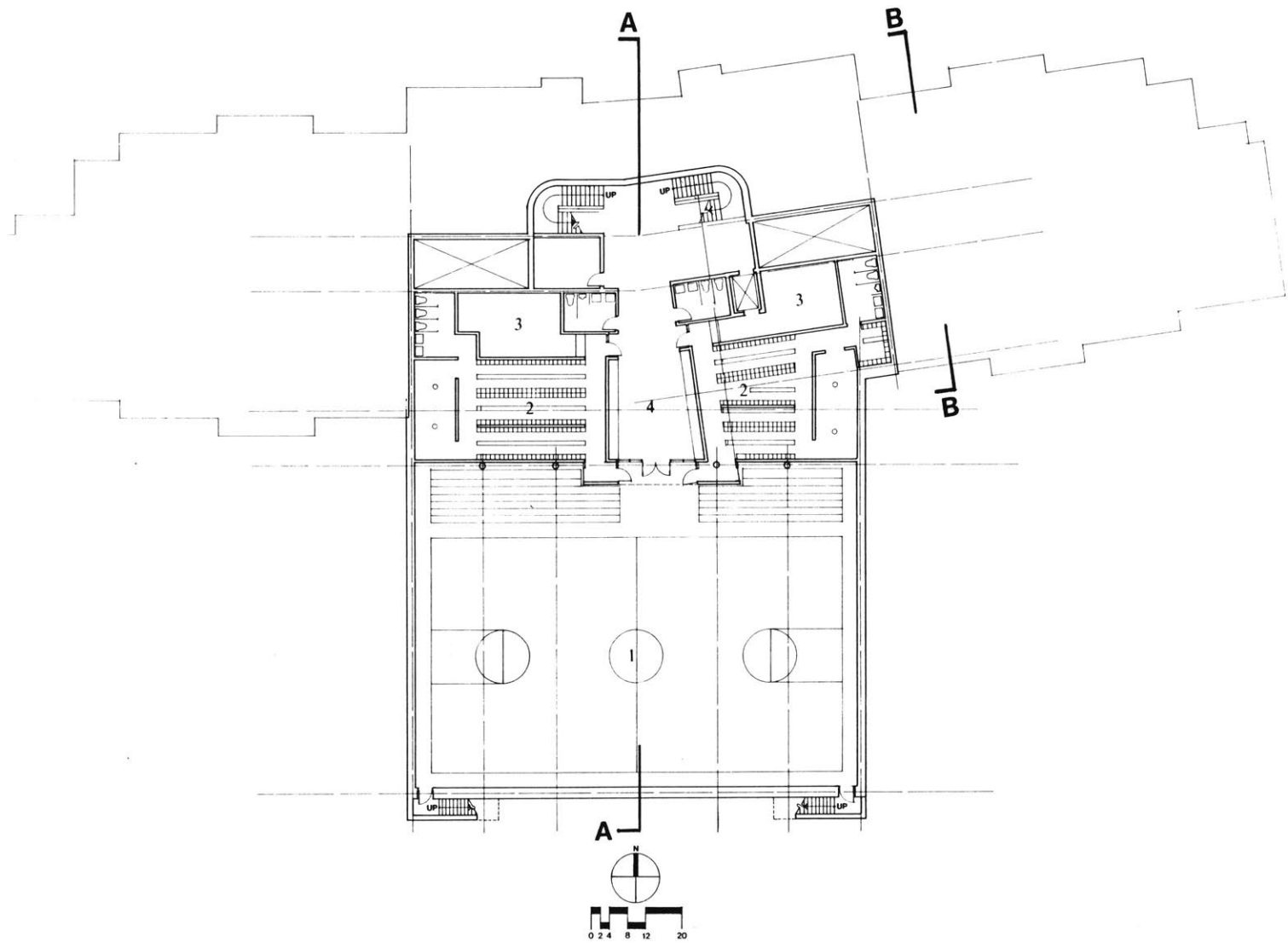

Fig. 100 Lower level plan, Freeport Middle School, Freeport Maine. KEY: 1. Gymnasium 2. Boys and Girls Locker rooms 3. Equipment storage and checkout counter 4. Trophy room and lobby.

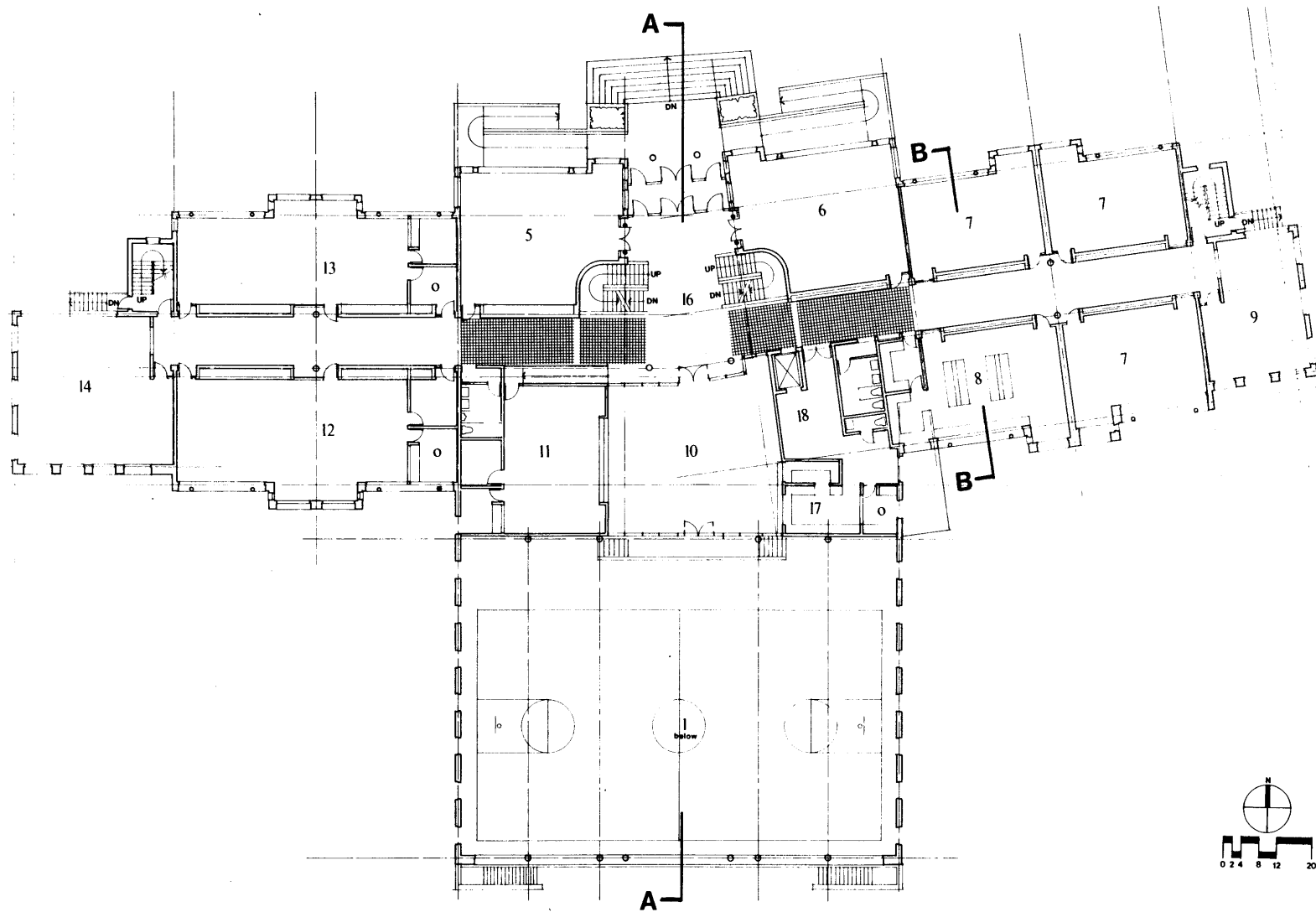

Fig. 101 First Floor Plan, Freeport Middle School, Freeport, Maine. KEY: 1.Gymnasium 5.Library 6.Administration 7.Classroom 8.Science classroom 9.Special education 10.Cafeteria/Auditorium 11.Music room 12.Arts and Crafts 13.Industrial Arts 14.Home economics 16.Entry hall 17.Warming kitchen 18.Maintenance room Note: Fine grid on portions of corridor floor denotes are of translucent floor.

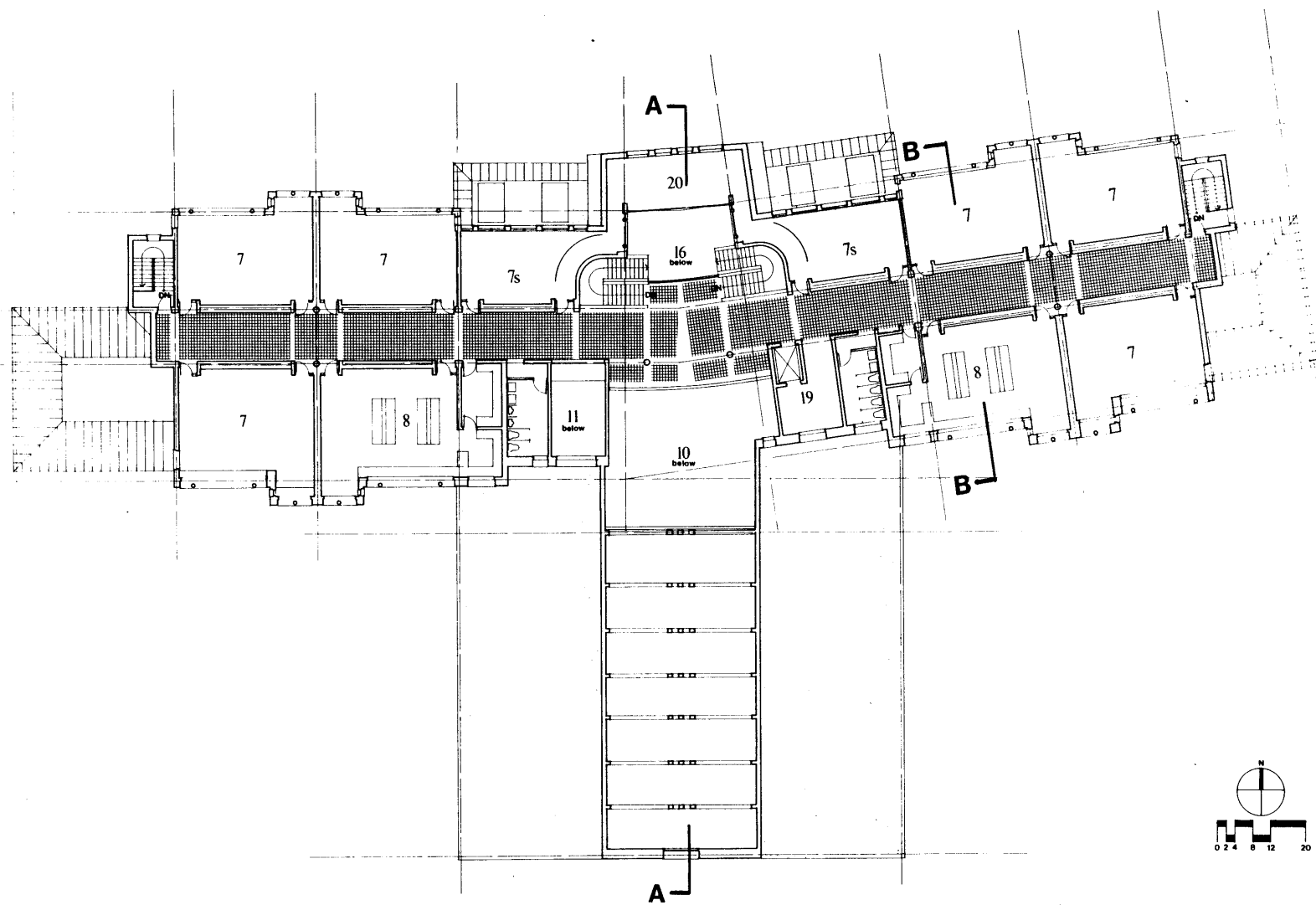
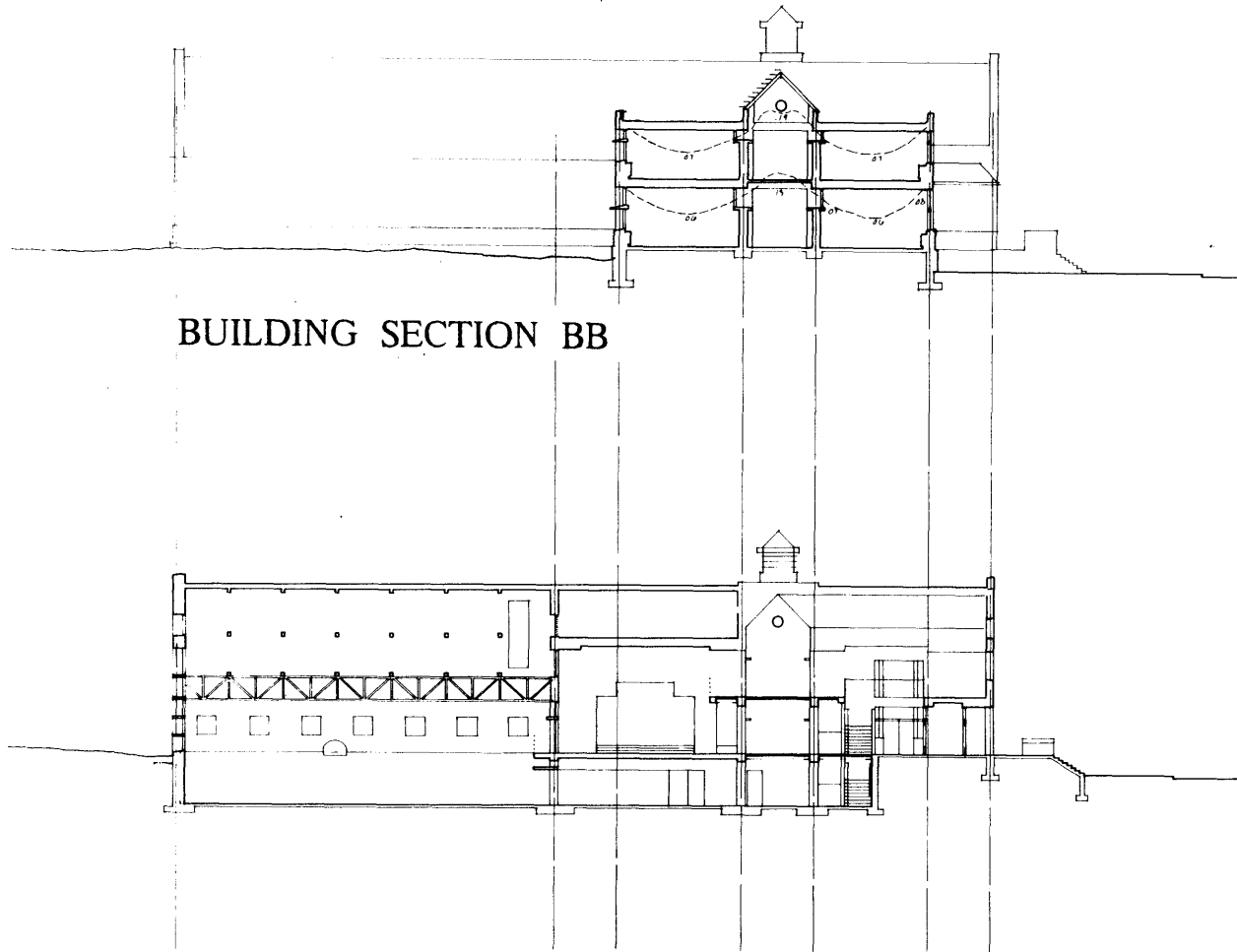

Fig. 102 Second Floor Plan, Freeport Middle School, Freeport, Maine. KEY: 7s.Small classroom 7.Classroom 8.Science classroom 10.Cafeteria/Auditorium (below) 11.Music room (below) 16.Entry hall (below) 19. Maintenance room 20.Student lounge. Note: Fine grid on portions of corridor floor denotes areas of translucent floor.



BUILDING SECTION AA



Fig. 103 Building Section AA and Building Section BB, Freepport Middle School, Freepport, Maine. Dashed line in section BB indicates daylight factor (DF) profile across section according to scale on lefthand side.

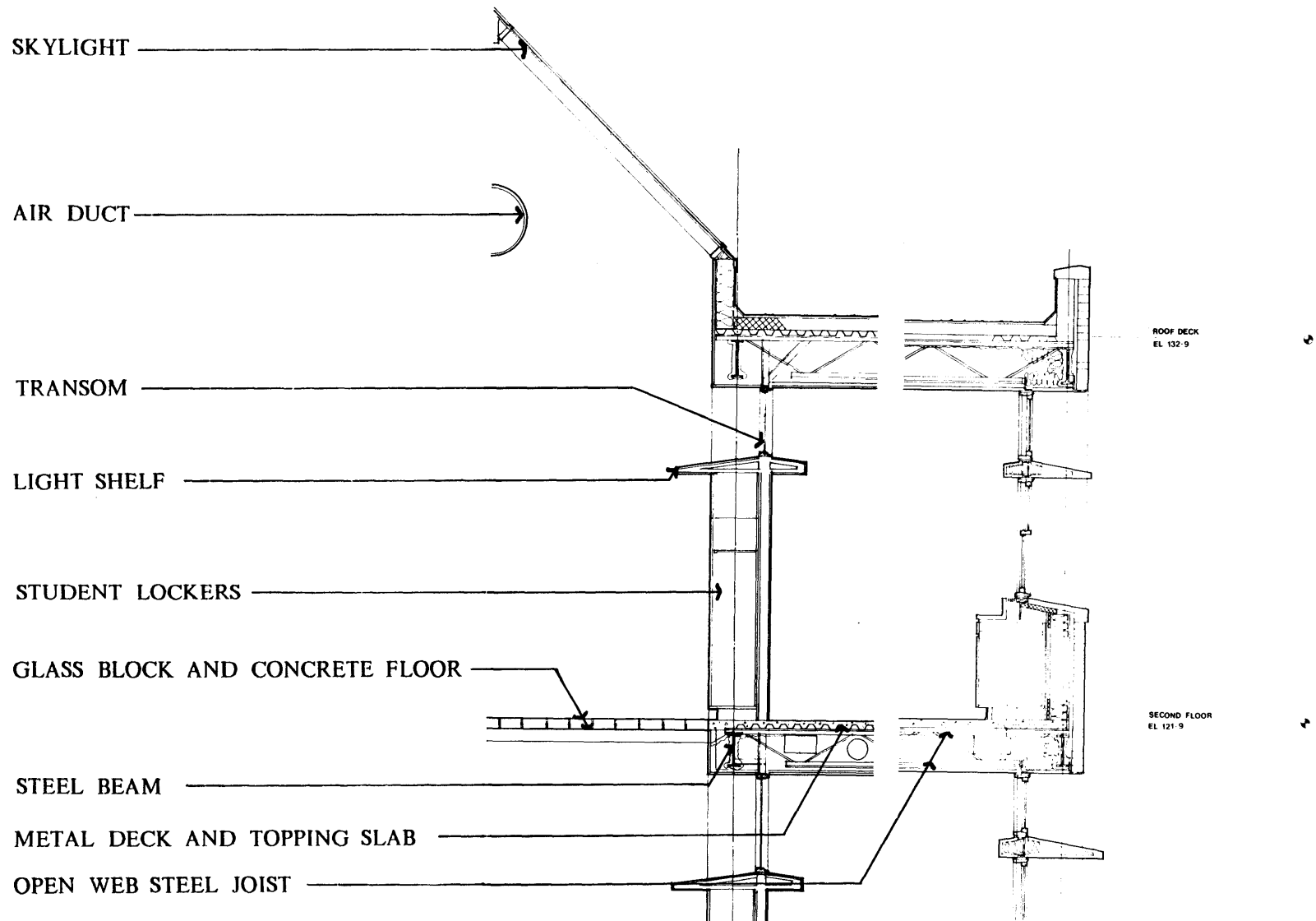

Fig. 104 Wall Sections, Freeport Middle School, Freeport, Maine. Showing the details of the translucent floor and interior and exterior light shelf configurations.

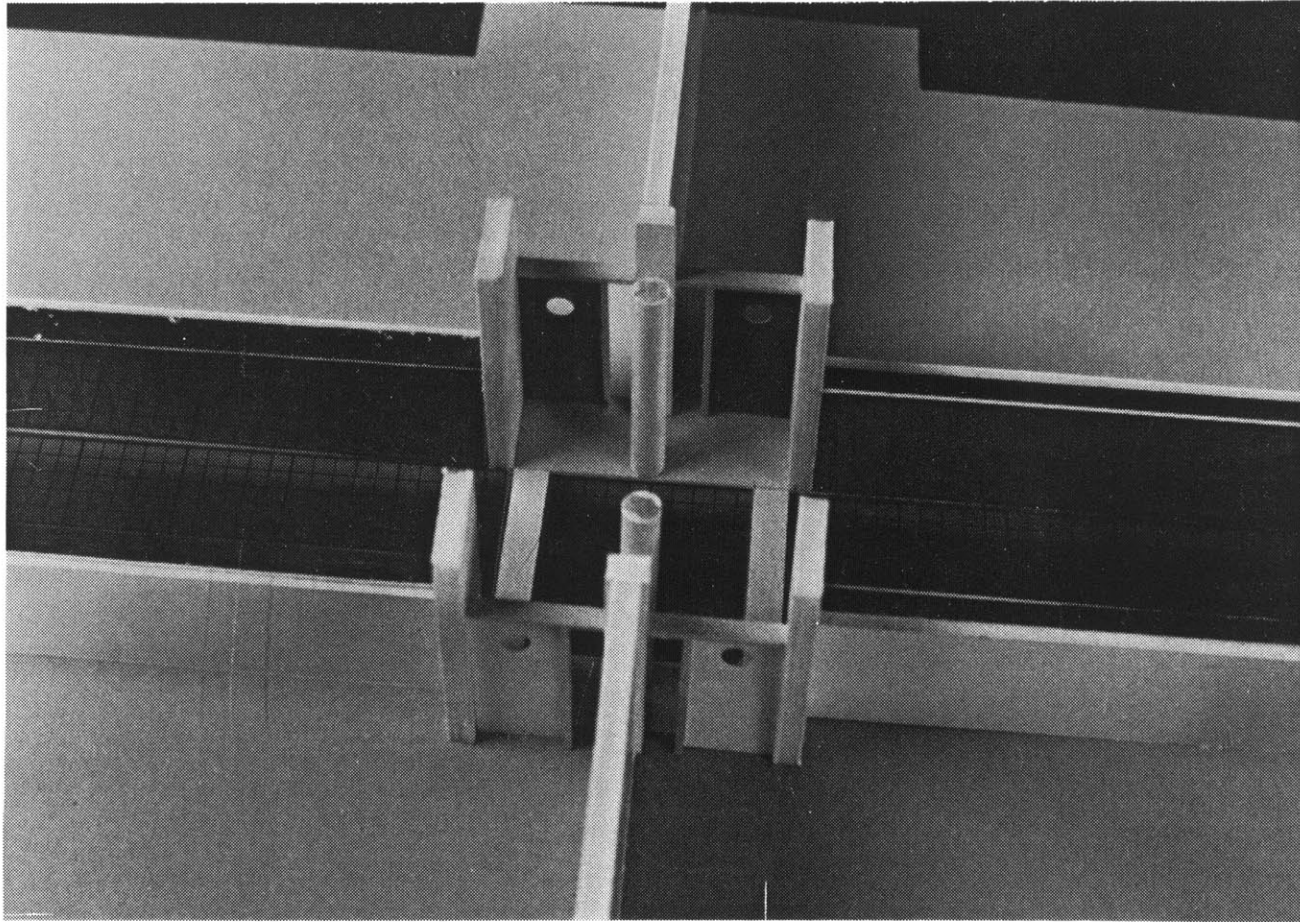

Fig. 105. Detail of classroom cluster model at entry to classrooms from the luminous spine.

In conclusion, with regard to these three prototypes, it is difficult to talk about the application of the translucent floor system to architecture without talking as well about the fundamental concepts of the architectural design. The consideration of this system must begin in the earliest stages of schematic design and be joined and blended together with other pertinent systems within the overall concepts of the building in order to be effective in a daylighting as well as a formal design sense. If the application of the translucent floor is done only to achieve daylighting, then it is probably not worth it. Admittedly, the traditional methods of toplighting via the open light shaft or atrium are more effective from a purely quantitative daylighting standpoint. In choosing this technology, it must serve other design purposes as well and by the nature of its duality it intrinsically does this. What makes the translucent floor so conceptually rich is that it is not merely a light well, but serves as a floor and a ceiling component simultaneously.

It is when these other characteristics as well as daylight transmission are called for that this technology becomes most effective. Whether it is a response to the pressures of building economics, local densities, programmatic efficiency, achieving better visual and acoustical privacy or fire resistance, the translucent floor system offers all of these in addition to daylighting performance.

CONCLUSIONS

This thesis has probed many of the aspects of the translucent floor system as they relate to the achievement of daylighting in architecture. In so doing, it has also uncovered some of the other features, presented in chapter 5, which, in conjunction with daylighting, this technology offers the architect. As a point of distinction from the traditional open shaft toplighting schemes, it is these other features which preface the application of translucent floor technology as a daylighting system.

As the application of the translucent floor light unfolds through the preceding chapters, the climatic and building conditions for which it is most appropriate and the configurations and construction which offer its greatest potential have been reviewed and established. In addition, the limitations of the translucent floor in its capacity to achieve daylighting beyond certain dimensions and transmission values have been delineated.

Of the three types of sky conditions, climates which tend to have prevailing overcast conditions offer the greatest daylighting potential to the toplighting configuration, whether it be an open or closed shaft. The measurements taken in the modeling presented in chapter 3 confirm this conclusion, showing a marked increase in the absolute interior illuminance

in foot candles as compared to clear sky conditions. The optical principles of refraction and diffusion which are exhibited by daylight offer an advantage to the use of floor lenses for light distribution and quality. The optical principle of transmission tends to put the translucent floor at a disadvantage in comparison to the open shaft; however, consideration of this leads to a construction which tends to maximize the ratio of glass to structure.

The modeling of translucent floor systems has shown that there are clear limits to the penetration of effective daylight given the transmission of the system, the room ratios and the reflectance of the interior walls. A well index in the range of three establishes the effective daylighting limit of the translucent floor regardless of the other parameters. Within this range, a decrease in well index, increase in wall reflectance, increase in floor light transmission, decrease of room ratio and proximity to interior partitions all tend to favor resultant increases in lighting levels. In addition, the presence of light shelves where light must be passed over a required partition can improve light distribution. Where practical, increases in floor light aperture with succeeding floor levels down from the initial skylight provides the most effective configuration.

The integration of the structural properties of the support structure and the translucent glass lens is the most effective way of improving the light transmission of the system. The

composite test panel confirmed that much of the concrete rib can be replaced by the compressive strength of the glass, improving the light transmission values as much as 30% over conventional panels. In terms of construction procedures, the relative precision required in the assembly of the system favors precasting over field casting to assure quality control. The use of strengthened plate glass lenses in conjunction with structural steel framing offers the highest overall light transmission values, but fire resistance, acoustical isolation and floor loading capacity are sacrificed as a result. There is no best structural system, but rather a number of choices open to the architect and client based on the requirements and specifics of the project.

Most of the above conclusions deal with the theoretical potential of the translucent floor light with respect to physical building parameters. Buildings are for people, however, and the patterns of their use and activity must be integrated with these physical building parameters. Circulation and building scheduling are the two primary aspects of use which tend to compliment the application of the translucent floor. The integration of floor and ceiling finish, structure and lighting in one building component offers a vast potential in decoration and design. The accomodation of building utilities in conjunction with this technology suggests solutions similar to other toplighting concepts with the most compatible being an exposed system. In this way these

systems serve a dual purpose of light diffuser as well as their primary function. The translucent floor system offers superior fire resistance, acoustical isolation and floor area efficiency (gross to net floor area ratio) in comparison to the traditional multi-story toplighting concept when these characteristics are required.

The most important conclusion of this thesis is related to the integration of the translucent floor system within the architectural design of a building. In the end, it cannot be considered separately, but rather as an overall building concept incorporating use, light, structure, finish and most of all the visual quality of design. The specific architectural prototypes show not just translucent floor technology, but more so, the integrated design solutions which it requires. Whether it is the idea of "light between the walls", light between the canopies or the luminous spine, each concept responds to the specific characteristics of the building type. In each case the translucent floor concept provides sufficient daylight and improved distribution over existing conditions within the constraints of land use density and building economics. It is important to keep these constraints in mind because it is their presence in the design process which suggests this technology over or in conjunction with the traditional open light shaft. These issues must exist in order to suggest the overlapping of the floor surface and daylight into one space.

The quantitative and qualitative daylight standards established in the modeling portion of this thesis set the minimum values and qualities which this daylighting and floor technology must achieve in order to be effective. Quantitatively, these values range from 1% to 3% for the minimum daylight standard depending on use and location. In each of the many floor light configurations modeled, some part of the plan or section remained close to the minimum daylight standard, and these zones mark the limits of this technology. Efforts to brighten these zones quickly exceeded the limits of practicality in terms of the functional translucency of a building program. In other words, as established in chapter 5, the circulation paths within the building pose the highest potential for the workability of this concept; however, once these areas have been exhausted, continued expansion of the translucent floor area begins to conflict with other program functions and ultimately proves impractical. The daylight factors in the final few tests of Appendix A are quite impressive, with values as high as 3% on the fourth floor down from the initial skylight. However, in most cases, it is difficult to apply this dimension of translucent floor in a practical way to the building plan without encountering some conflict. Nevertheless, the corridors in the Freeport Middle School are 14'-0" wide, and in this application dimensions of this scale are programmatically practical.

The point is that placing the theoretical potential of the translucent floor in the context of the building program puts this concept on the borderline of the minimum daylight standard (1% to 3 % daylight factor). Each of the three prototypes is pressing the limits of the application of this technology to architecture and yet the daylighting effectiveness in some parts of these examples remains marginal. In the rowhouses it is the back wall of the kitchen. In the lowrise office building it is around the central column of each bay and in the school building it is in the lower level locker rooms. Yet, with the exception of these few trouble spots, the translucent floor is effective in daylighting a substantial portion of the space. In all cases the translucent floor system is proposed in conjunction with some perimeter daylighting as a means of balancing light levels of the core zone with respect to the perimeter. When viewed as an additive daylight factor, on top of diminishing perimeter levels, in most cases the marginal increase is enough to justify its application. In general, the translucent floor light is most effective and practical, quantitatively, in the initial floor of skylit rooms. Application in succeeding floors is only marginally effective and recommended only where well indexes can be kept within a value of three and light transmission on the order of 70%.

In terms of the qualitative aspects of daylight, the results from the modeling are mixed. A review of the floor light

configurations in Appendix A confirms that for the most part the daylight factors across the plan are within the factor of two criterion for even distribution of daylight. It is also clear that as long as the daylight levels remain effective, each successive pass through an additional floor light results in improved distribution. The results from the modeling of the Freeport Middle School likewise show that when properly balanced in conjunction with other daylight sources and with the use of light redirecting accessories such as light shelves and diffusers, the translucent floor light offers an opportunity for glare free, evenly distributed daylight. On the other hand, the light distribution modeled in the other two prototypes, though glare free, exceeds the criteria for even distribution. In both cases the models suffer from an excess of light beneath the translucent floor, on the circulation path and a deficiency of light in the extremities of the plan. As mentioned in each of these cases, the addition of some light redirecting measures such as light shelves or reflective canopies may be effective in alleviating these distribution problems. The distribution problems developed in some of these prototypes suggest that half of the solution of the translucent floor is getting enough light to pass through it. The other half of the solution is to redirect some of the light to the darker portions of the plan and achieve even distribution. Although some of the modeling and prototypes represent complete

solutions employing this technology, there remains additional work in the area of light distribution.

Beyond the considerations of glare and distribution, the translucent floor brings a new vocabulary of light and material to the formal design considerations of these building types. The idea of luminous and diaphanous building surfaces in the floor as well as the walls revolutionizes the architectural notions of solid and void and offers a new range of design options which have just begun to be explored in these limited prototypes. Possible variations in color, texture, and pattern offer a fresh, unlimited palette of material and light with which the architect can work.

This thesis lays the groundwork for further investigation into the application of translucent floor technology in architecture. In the area of the the integration of translucency and structure, there remains a program of testing which this thesis has just begun to address. The limits of the light transmission of this system can still be expanded as new materials and composites become available. The application of translucent plastics in place of the glass lens is an area of research which can drastically reduce the possible breakage and weight of the system. Recent applications of the idea of translucent terrazzo have been explored as a dramatic interior design for floor and wall finishes. Research needs to be done to carry this idea one step further towards its application to the totally translucent floor material. The

potential of better and further light distribution through new lens shapes is another area where further work can be focused.

Throughout this thesis, it was assumed that all furniture was opaque and consequently led to a incompatibility with the translucent floor. However, translucency is as applicable to furniture as it is to architecture. Further work needs to be done in the accessory systems to the translucent floor of which furniture is one. Some of the other light distribution accessories to which this thesis is merely an introduction are light shelf integration with furniture systems, ceiling grid diffusing systems, and the potential of further distribution through exposed mechanical systems.

All the recommendations in this thesis are founded on the premise that the initial skylight opening is admitting only daylight which is incident on the simple aperture of the skylight. Recent advances in daylight amplification and redirecting devices at the initial skylight such as the fresnel mirror lenses and the concept of passive solar optics have shown great promise as applied to the open light shaft daylighting systems. The principle behind these devices is to achieve light amplification through the coordinated positioning of specular reflectors or mirrors which are able to focus a broad range of the sky and direct beam light into a relatively narrow beam of redirected light. The resultant beam of light can be coordinated with the configuration of

even narrow light wells in order to project the initial range of the source skylight deep into the interior of the building. Although some serious glare problems remain in this concept, the application of similar devices to the translucent floor system is another topic for further research.

Until this thesis, the investigation into the daylighting and architectural applications of the translucent floor had, for the most part, laid dormant in the flourish of work done during the early part of this century. Many of the conclusions of this investigation establish the limitations as well as the potential of this revolutionary idea of the synthesis of light, structure and space in one technology. With the limitations as a guide and the design potential as the driving force, the path lays before us to walk on daylight.

-
- (1) Lardstrom, Bjorn. "The Ship." (New York: Doubleday and Co.), 1961, p. 156.
 - (2) Gloag, John and Bridgewater, Derek. "A History of Cast Iron in Architecture." (London: George Allen and Unwin Ltd.) 1948, p. 192.
 - (3) Ibid., p. 196.

- (4) McGrath and Roth, "Glass in Architecture and Decoration," (London: The Architectural Press.) 1937, p. 180.
- (5) Ibid., p. 180.
- (6) Ibid., p. 181.
- (7) Ibid., p. 182.
- (8) Ibid., p. 186.
- (9) Whyte, Iain B. "Bruno Taut and the Architecture of Activism," (Cambridge: Cambridge University Press,) 1982, p. 32.
- (10) Ibid., p. 33.
- (11) Evans, Benjamin. "Daylight in Architecture," (New York: McGraw-HillBook Co.,) 1981, pp. 96-105.
- (12) Ibid.
- (13) Egan, M. David. "Concepts in Architectural Lighting", (New York: McGraw Hill Book Co.), 1983, p. 201.
- (14) Ibid., p. 200.
- (15) Bartovics, William. "The Thermal Performance of Fixed and Variable Transmitters in Commercial Architecture," S.M.ArchS. Thesis, Department of Architecture, M.I.T., Cambridge, MA, 1984.
- (16) Malamuceanu, Roland D., "Atrium House Solar Revitalization," S.M.Arch.S. Thesis, M.I.T., Department of Architecture, Cambridge, MA, 1984.

APPENDIX A

The sequence of daylight model isometric diagrams, accompanying tables and remarks represents the range of and results from the testing. Some tests have been deleted between each sequence in order to more easily trace the overall trends in illumination levels resulting from the variation of a number of model parameters. The measurements were taken during the daylight hours as indicated in each test beginning on 3-6-85 up until 3-23-85. In each of the tables accompanying the diagrams the letter "T" is an abbreviation for transmission and "REFLECT." is an abbreviation for reflectance. The North and East walls have been removed in the isometric drawing in order to diagram the interior floor lights and list the specific daylight factors resulting from each combination. The shaded portions of each floor level denote the extent of the translucent floor light. Each of the specific test combinations may be interpreted individually given the various parameters in the table or when taken as a group, can be used to derive general relationships between aspect ratio or well index, wall reflectance, room cavity ratio, floor light and skylight transmission, aperture size and resulting daylight factors or absolute illumination levels (fc).

FLOOR LIGHT PHYSICAL MODELING TEST 01

SKY CONDITION:clear sky
 TIME OF DAY:4:55PM

WALL	N	E	S	W
ORIENTATION				
SKYLIGHT SIZE=	4'-0"x4'-0" T=65%			
WALL				
REFLECT.	10%	10%	10%	10%
1ST FLOOR LIGHT SIZE=	2'-0"x2'-0" T=85%			
WALL				
REFLECT.	10%	10%	10%	10%
2ND FLOOR LIGHT SIZE=	2'-0"x2'-0" T=85%			
WALL				
REFLECT.	10%	10%	10%	10%
3RD FLOOR LIGHT SIZE=	2'-0"x 2'-0" T=85%			

FLOOR REFLECTANCE= 45%
 (Typical all floors)

	1ST	2ND	3RD	4TH
CEILING				
REFLECT.=	80%	80%	80%	80%
CEILING				
HEIGHT=	8'-6"	8'-6"	8'-6"	8'-6"

REMARKS: This series of floor light apertures establishes the minimum daylight level and suggests that all additional modeling proceed toward larger apertures, smaller room sizes, and higher wall reflectances.

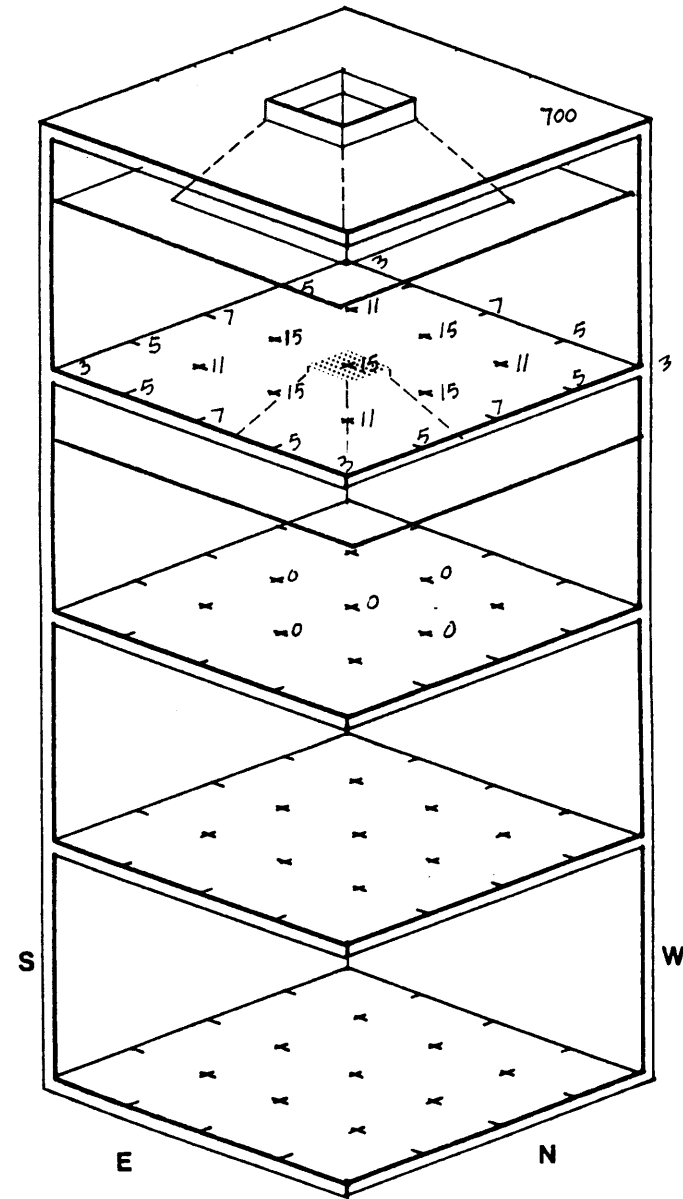

FLOOR LIGHT PHYSICAL MODELING TEST 02

SKY CONDITION: clear sky 5000 fc
 TIME OF DAY: 11:30 AM

WALL	N	E	S	W
ORIENTATION				
SKYLIGHT SIZE=	4'-0"x 4'-0" T=65%			
WALL				
REFLECT.	80%	80%	10%	10%
1ST FLOOR LIGHT SIZE=	2'-0"x 2'-0" T=85%			
WALL				
REFLECT.	80%	80%	80%	10%
2ND FLOOR LIGHT SIZE=	2'-0"x 2'-0" T=85%			
WALL				
REFLECT.	10%	80%	10%	10%
3RD FLOOR LIGHT SIZE=	none			

FLOOR REFLECTANCE= 45%
 (Typical all floors)

	1ST	2ND	3RD	4TH
CEILING				
REFLECT.=	80%	80%	80%	-
CEILING				
HEIGHT=	8'-6"	8'-6"	8'-6"	8'-6"

REMARKS: Decreased room cavity ratio. Increased wall reflectances.

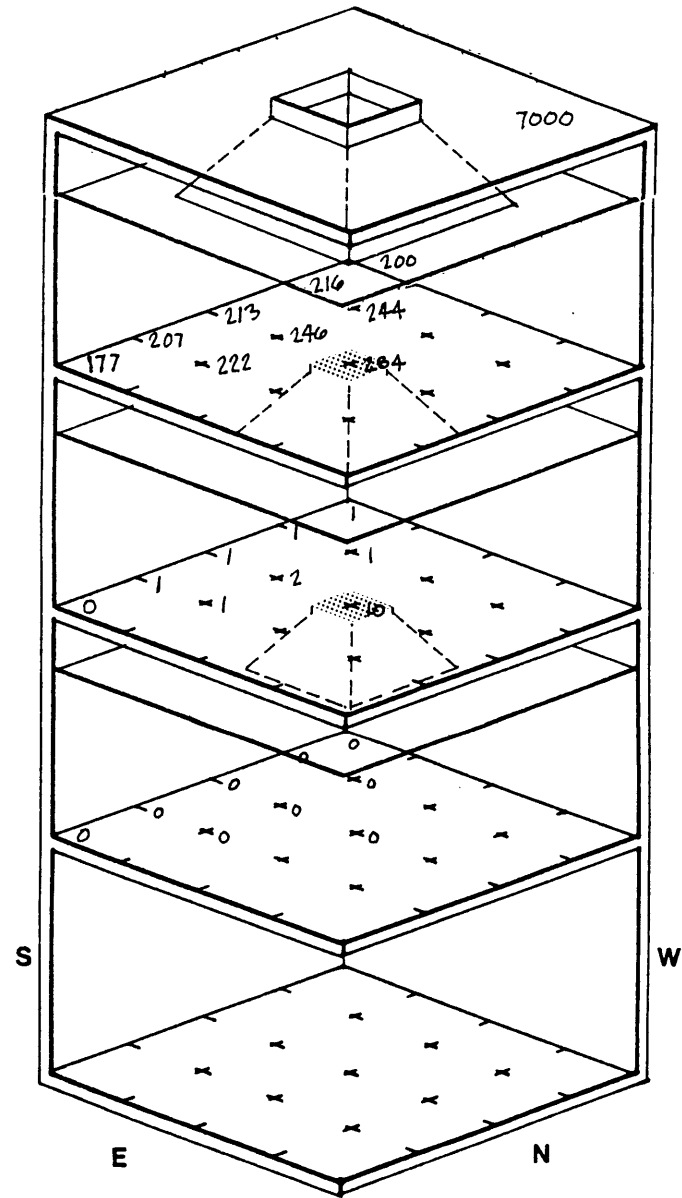

FLOOR LIGHT PHYSICAL MODELING TEST 03

SKY CONDITION: overcast
 TIME OF DAY: 3:50 PM

WALL	N	E	S	W
ORIENTATION				
SKYLIGHT SIZE=	4'-0" x 4'-0" T=65%			
WALL				
REFLECT.	80%	100%	100%	80%
1ST FLOOR LIGHT SIZE=	16'-0" x 16'-0" T=70%			
WALL				
REFLECT.	80%	80%	80%	80%
2ND FLOOR LIGHT SIZE=	6'-0" x 6'-0" T=50%			
WALL				
REFLECT.	80%	80%	80%	10%
3RD FLOOR LIGHT SIZE=	6'-0" x 6'-0" T=50%			

FLOOR REFLECTANCE= 45%
 (Typical all floors)

	1ST	2ND	3RD	4TH
CEILING				
REFLECT.=	80%	50%	70%	-
CEILING				
HEIGHT=	8'-6"	11'-0"	8'-6"	8'-6"

REMARKS: Increased floor light apertures. Increased room cavity ratio. Wall reflectances remain the same.

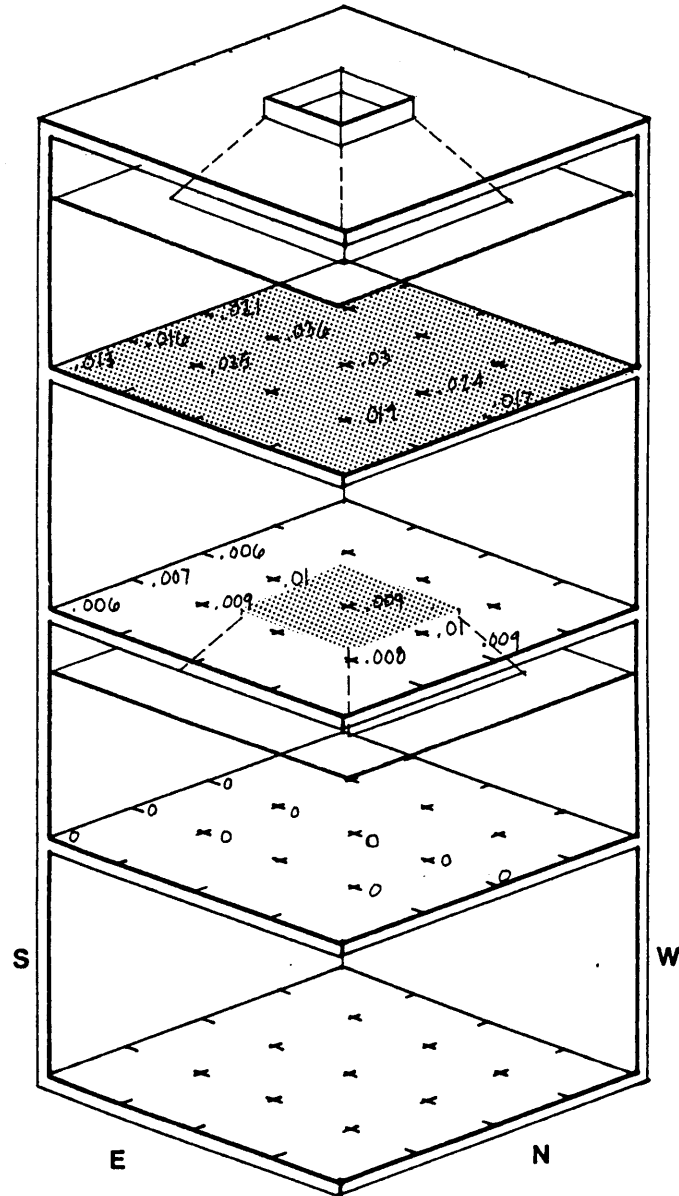

FLOOR LIGHT PHYSICAL MODELING TEST 04

SKY CONDITION: clear sky (shaded photometers) 1600-1800 fc
 TIME OF DAY: 1:15 PM

WALL N E S W
 ORIENTATION
 SKYLIGHT SIZE= 4'-0"x 4'-0" T=65%
 WALL
 REFLECT. 80% 80% 100% 100%
 1ST FLOOR LIGHT SIZE= 16'-0"x16'-0" T=70%
 WALL
 REFLECT. 80% 80% 80% 10%
 2ND FLOOR LIGHT SIZE= 16'-0"x 16'-0" T=70%
 WALL
 REFLECT. 80% 80% 100% 80%
 3RD FLOOR LIGHT SIZE= 6'-0"x6'-0" T=50%

FLOOR REFLECTANCE= 45%
 (Typical all floors)

	1ST	2ND	3RD	4TH
CEILING				
REFLECT.=	70%	50%	50%	-
CEILING				
HEIGHT=	8'-6"	11'-0"	11'-0"	8'-6"

REMARKS: Increased floor light apertures. Decreased room cavity ratio from test 03. Wall reflectances remain the same.

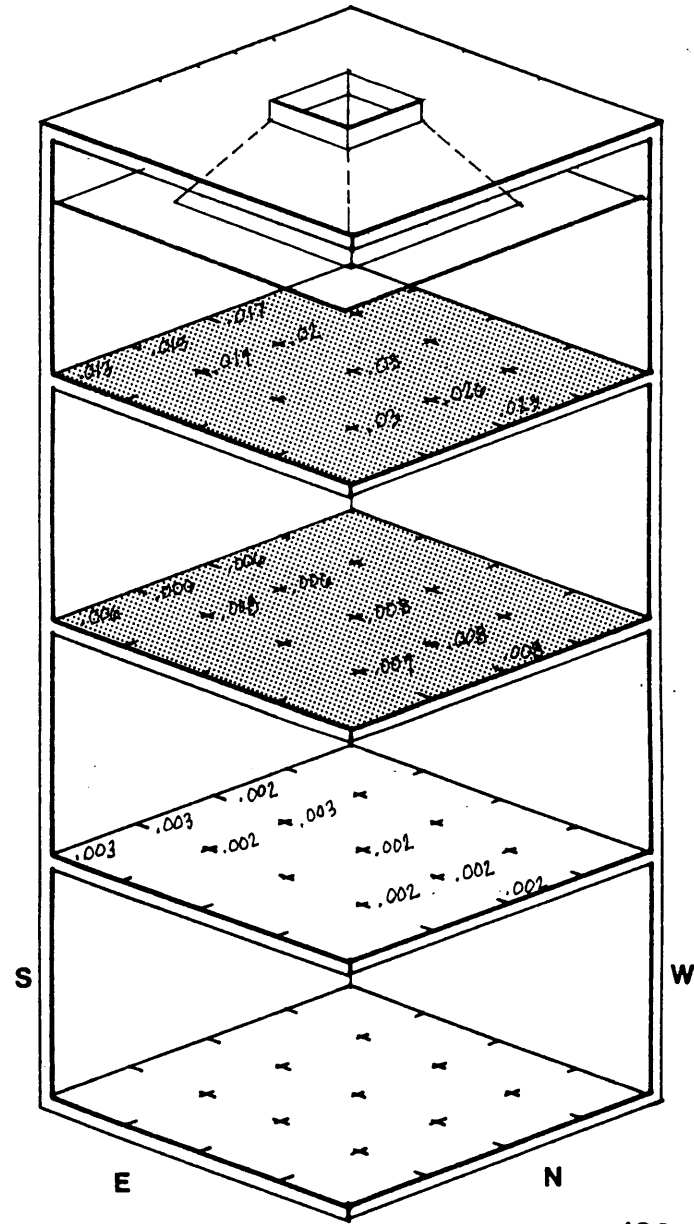

FLOOR LIGHT PHYSICAL MODELING TEST 05

SKY CONDITION: clear sky (shaded meters)
 TIME OF DAY: 4:30 PM

WALL N E S W

ORIENTATION

SKYLIGHT SIZE= 4'-0"x 4'-0" T=65%

WALL

REFLECT. 10% 10% 10% 10%

1ST FLOOR LIGHT SIZE= 16'-0"x 16'-0" T=70%

WALL

REFLECT. 10% 10% 10% 10%

2ND FLOOR LIGHT SIZE= 16'-0"x 16'-0" T=70%

WALL

REFLECT. 10% 10% 10% 10%

3RD FLOOR LIGHT SIZE= 16'-0"x 16'-0" T=70%

WALL

REFLECT. 10% 10% 10% 10%

FLOOR REFLECTANCE= 45%

(Typical all floors)

	1ST	2ND	3RD	4TH
CEILING				
REFLECT.=	50%	50%	50%	50%
CEILING				
HEIGHT=	8'-6"	11'-0"	11'-0"	11'-0"

REMARKS: Increased floor light aperture size on 3rd floor.
 Increased room cavity ratio. Decreased wall reflectances.
 Readings taken late in the day may have very little
 horizontal plane illuminance component causing a toplighting
 scheme to become ineffective at these times regardless of
 the floorlight apertures.

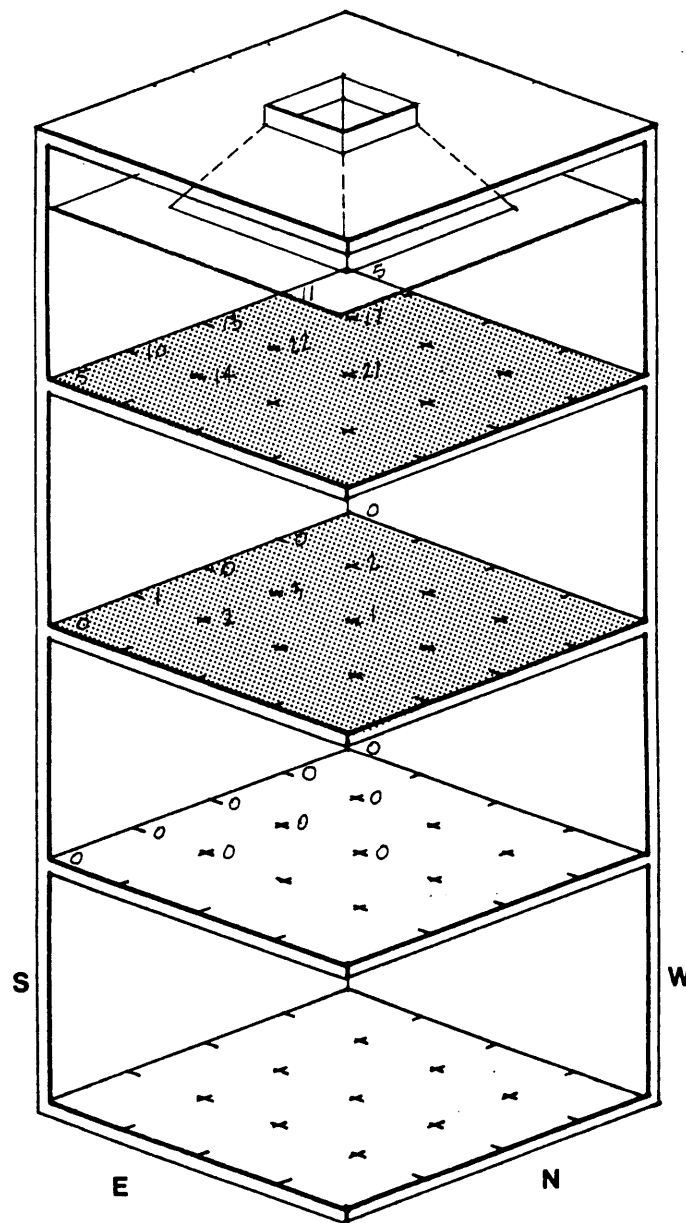

FLOOR LIGHT PHYSICAL MODELING TEST 06

SKY CONDITION: partly cloudy 4500-5500 fc
 TIME OF DAY: 11:50 AM

WALL	N	E	S	W
ORIENTATION				
SKYLIGHT SIZE=	6'-0"x 6'-0" T=65%			
WALL				
REFLECT.	80%	80%	10%	10%
1ST FLOOR LIGHT SIZE=	2'-0"x 2'-0" T=85%			
WALL				
REFLECT.	80%	80%	80%	10%
2ND FLOOR LIGHT SIZE=	2'-0"x 2'-0" T=85%			
WALL				
REFLECT.	-	-	-	-
3RD FLOOR LIGHT SIZE=	-			

FLOOR REFLECTANCE= 45%
 (Typical all floors)

	1ST	2ND	3RD	4TH
CEILING				
REFLECT.=	80%	80%	80%	-
CEILING				
HEIGHT=	8'-6"	8'-6"	8'-6"	-

REMARKS: Increased skylight aperture. Room cavity ratio and wall reflectances remain the same as test 02.

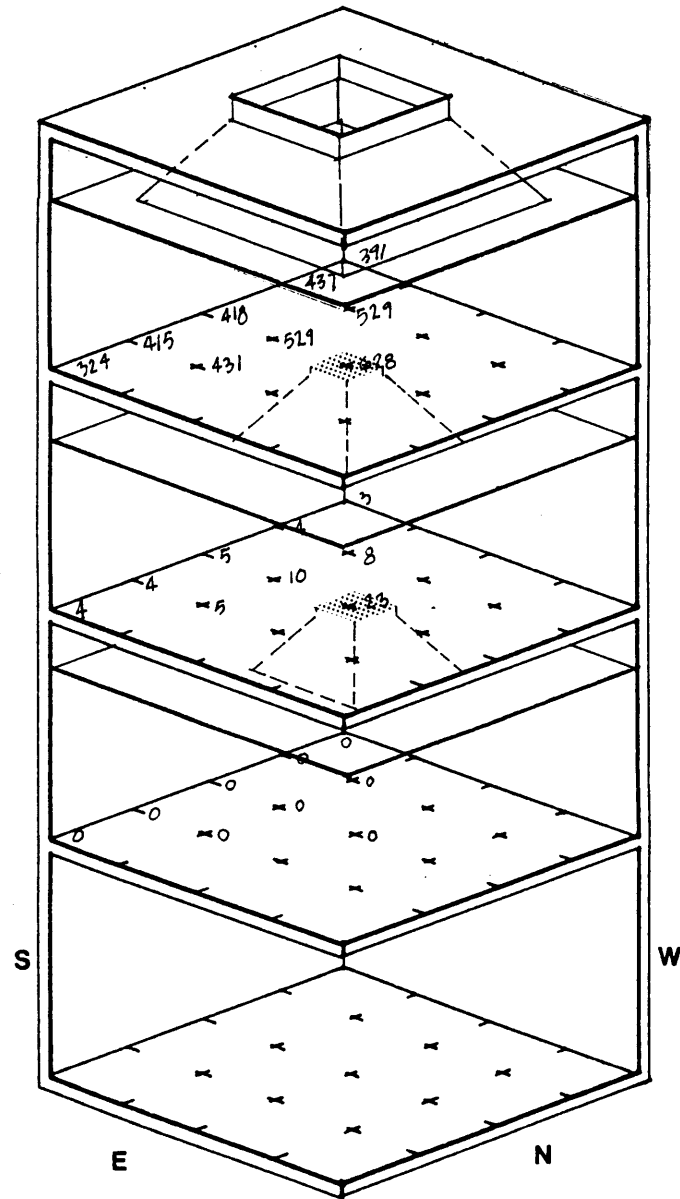

FLOOR LIGHT PHYSICAL MODELING TEST 07

SKY CONDITION: partly cloudy 5500-6000fc
 TIME OF DAY: 12:30 PM

WALL N E S W
 ORIENTATION
 SKYLIGHT SIZE= 6'-0"x 6'-0" T=65%
 WALL
 REFLECT. 80% 80% 80% 80%
 1ST FLOOR LIGHT SIZE= 6'-0"x 6'-0" T=50%
 WALL
 REFLECT. 80% 80% 80% 80%
 2ND FLOOR LIGHT SIZE= 2'-0"x 2'-0" T=85%
 WALL
 REFLECT. - - - -
 3RD FLOOR LIGHT SIZE= -
 - - - -
 FLOOR REFLECTANCE= 45%
 (Typical all floors)

	1ST	2ND	3RD	4TH
CEILING				
REFLECT.=	70%	70%	75%	-
CEILING				
HEIGHT=	8'-6"	8'-6"	8'-6"	-

REMARKS: Increased floor light aperture on 1ST floor.
 Decreased room cavity ratio. Increased wall reflectances. No readings taken from 3rd or 4th floor.

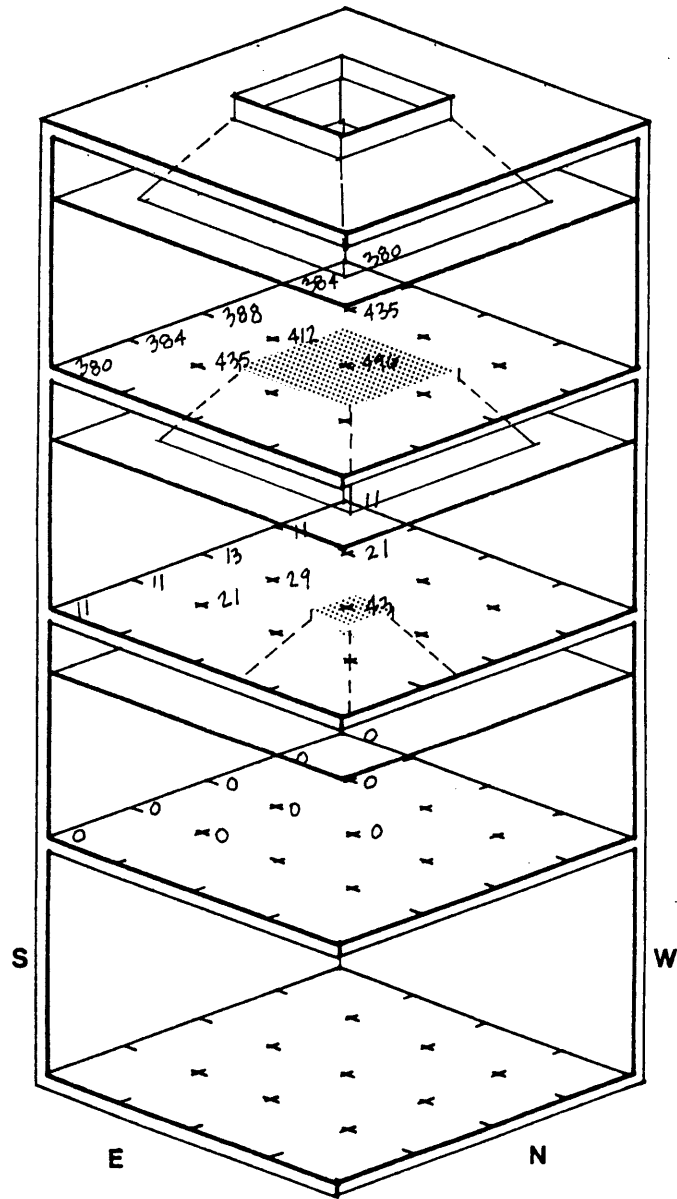

FLOOR LIGHT PHYSICAL MODELING TEST 08

SKY CONDITION: partly cloudy 2500-5000fc
 TIME OF DAY: 2:40 PM

WALL	N	E	S	W
ORIENTATION				
SKYLIGHT SIZE=	6'-0"x 6'-0" T=65%			
WALL				
REFLECT.	10%	100%	100%	10%
1ST FLOOR LIGHT SIZE=	16'-0"x 16'-0" T=70%			
WALL				
REFLECT.	10%	10%	10%	10%
2ND FLOOR LIGHT SIZE=	6'-0"x 6'-0" T=50%			
WALL				
REFLECT.	10%	10%	10%	10%
3RD FLOOR LIGHT SIZE=	6'-0"x 6'-0" T=50%			

FLOOR REFLECTANCE= 45%
 (Typical all floors)

	1ST	2ND	3RD	4TH
CEILING				
REFLECT.=	70%	50%	70%	-
CEILING				
HEIGHT=	8'-6"	11'-0"	8'-6"	-

REMARKS: Increased floor light aperture on 1st, 2nd and 3rd floors. Increased room cavity ratios. 1st floor room 32'-0"x 32'-0" with four skylights identical to original, equally spaced on center. Decreased wall reflectances.

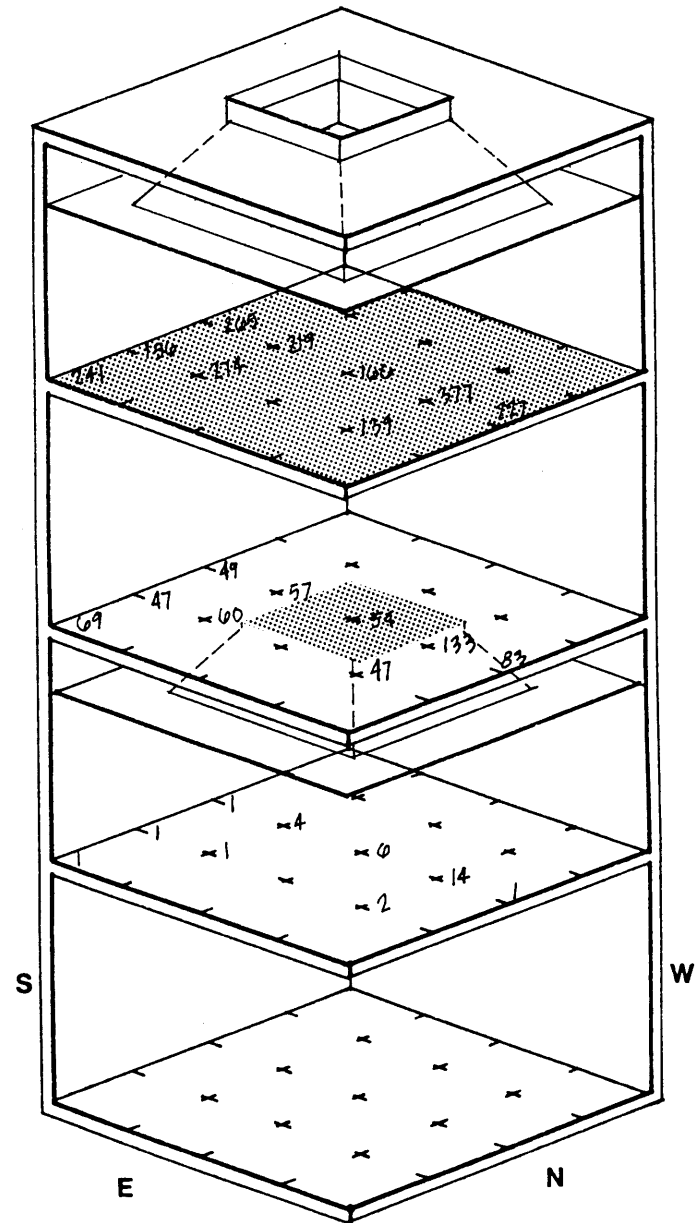

FLOOR LIGHT PHYSICAL MODELING TEST 09

SKY CONDITION: overcast 1000 fc
 TIME OF DAY: 3:05 PM

WALL	N	E	S	W
ORIENTATION				
SKYLIGHT SIZE=	6'-0"x 6'-0" T=65%			
WALL				
REFLECT.	80%	100%	100%	80%
1ST FLOOR LIGHT SIZE=	16'-0"x16'-0" T=70%			
WALL				
REFLECT.	80%	80%	80%	80%
2ND FLOOR LIGHT SIZE=	6'-0"x 6'-0" T=50%			
WALL				
REFLECT.	80%	80%	80%	10%
3RD FLOOR LIGHT SIZE=	6'-0"x 6'-0" T=50%			

FLOOR REFLECTANCE= 45%
 (Typical all floors)

	1ST	2ND	3RD	4TH
CEILING				
REFLECT.=	70%	50%	70%	70%
CEILING				
HEIGHT=	8'-6"	11'-0"	8'-6"	8'-6"

REMARKS: Floor light apertures remain the same. Decreased room cavity ratios. Increased wall reflectances as noted.

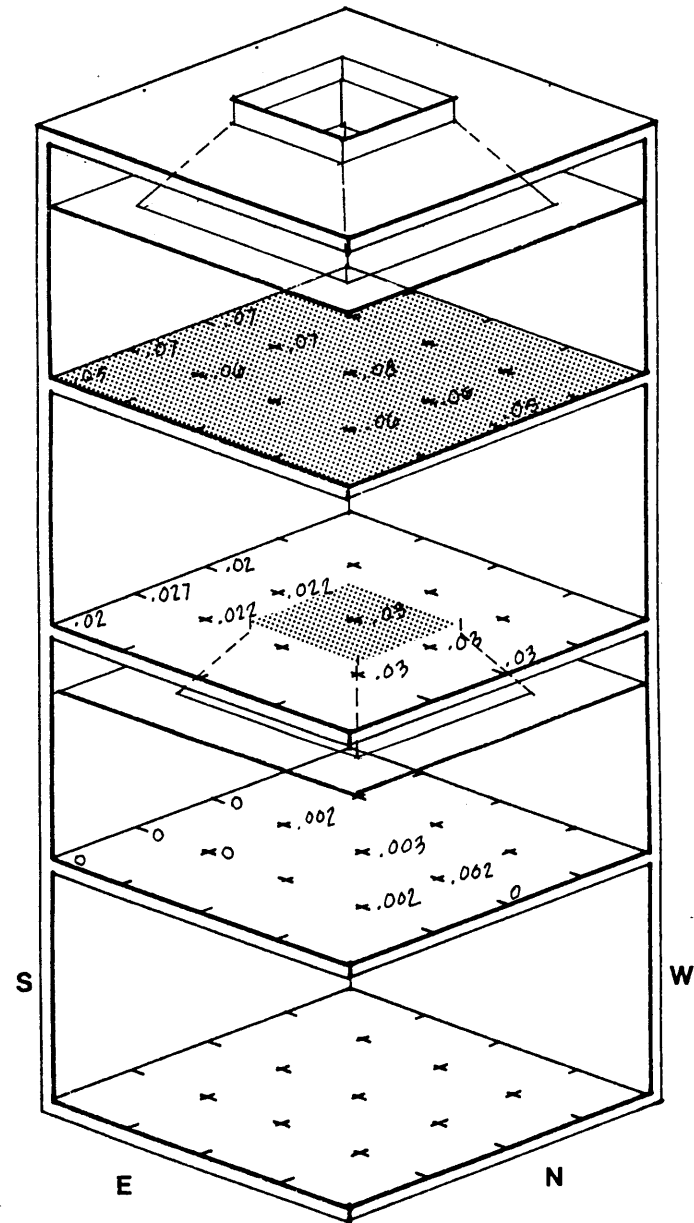

FLOOR LIGHT PHYSICAL MODELING

TEST 10

SKY CONDITION: partly cloudy
 TIME OF DAY: 2:30 PM

WALL N E S W
 ORIENTATION
 SKYLIGHT SIZE= 6'-0"x 6'-0" T=65%
 WALL
 REFLECT. 80% 100% 100% 10%
 1ST FLOOR LIGHT SIZE= 16'-0"x 16'-0" T=70%
 WALL
 REFLECT. 80% 80% 80% 80%
 2ND FLOOR LIGHT SIZE= 12'-0"x 12'-0" T=70%
 WALL
 REFLECT. 80% 100% 100% 80%
 3RD FLOOR LIGHT SIZE= 6'-0"x 6'-0" T=65%

FLOOR REFLECTANCE= 45%
 (Typical all floors)

	1ST	2ND	3RD	4TH
CEILING				
REFLECT.=	70%	50%	50%	70%
CEILING				
HEIGHT =	8'-6"	11'-0"	11'-0"	8'-6"

REMARKS: Increased floor light aperture on 2nd floor.
 Decreased room cavity ratio. Increased wall reflectances.
 Good general lighting levels on 1st and 2nd floors. Lighting
 levels on 3rd floor adequate for circulation and accessory
 spaces only.

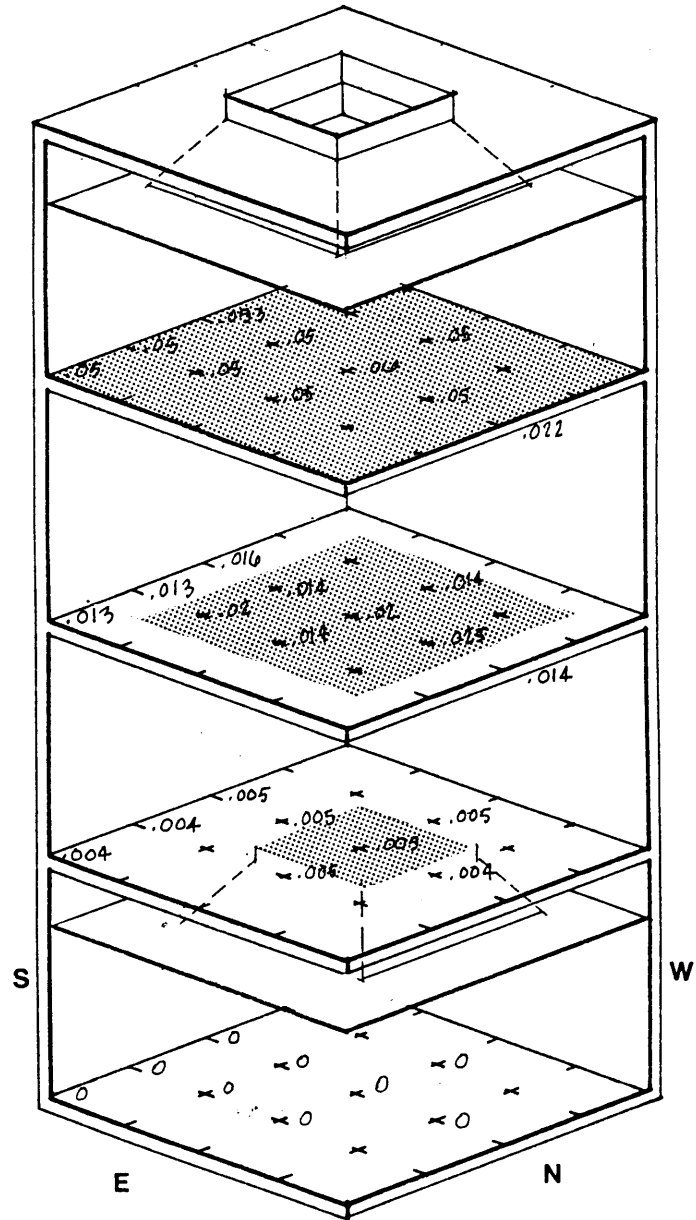

FLOOR LIGHT PHYSICAL MODELING

TEST 11

SKY CONDITION: overcast 1900 fc
 TIME OF DAY: 1:30 PM

WALL N E S W
 ORIENTATION
 SKYLIGHT SIZE= 6'-0"x 6'-0" T=65%
 WALL
 REFLECT. 10% 100% 10% 10%
 1ST FLOOR LIGHT SIZE= 16'-0"x16'-0" T=70%
 WALL
 REFLECT. 10% 100% 10% 10%
 2ND FLOOR LIGHT SIZE= 16'-0"x16'-0" T=70%
 WALL
 REFLECT. 10% 100% 10% 10%
 3RD FLOOR LIGHT SIZE= 6'-0"x6'-0" T=65%

FLOOR REFLECTANCE= 45%
 (Typical all floors)

	1ST	2ND	3RD	4TH
CEILING				
REFLECT.=	70%	50%	50%	70%
CEILING				
HEIGHT =	8'-6"	11'-0"	11'-0"	8'-6"

REMARKS: Increased floor light aperture on 2nd floor.
 Increased room cavity ratio on all floors. Mirror on East wall simulates apertures 2x actual size. Good general daylight levels on 1st floor with levels on 2nd floor adequate for circulation and other accessory spaces only.

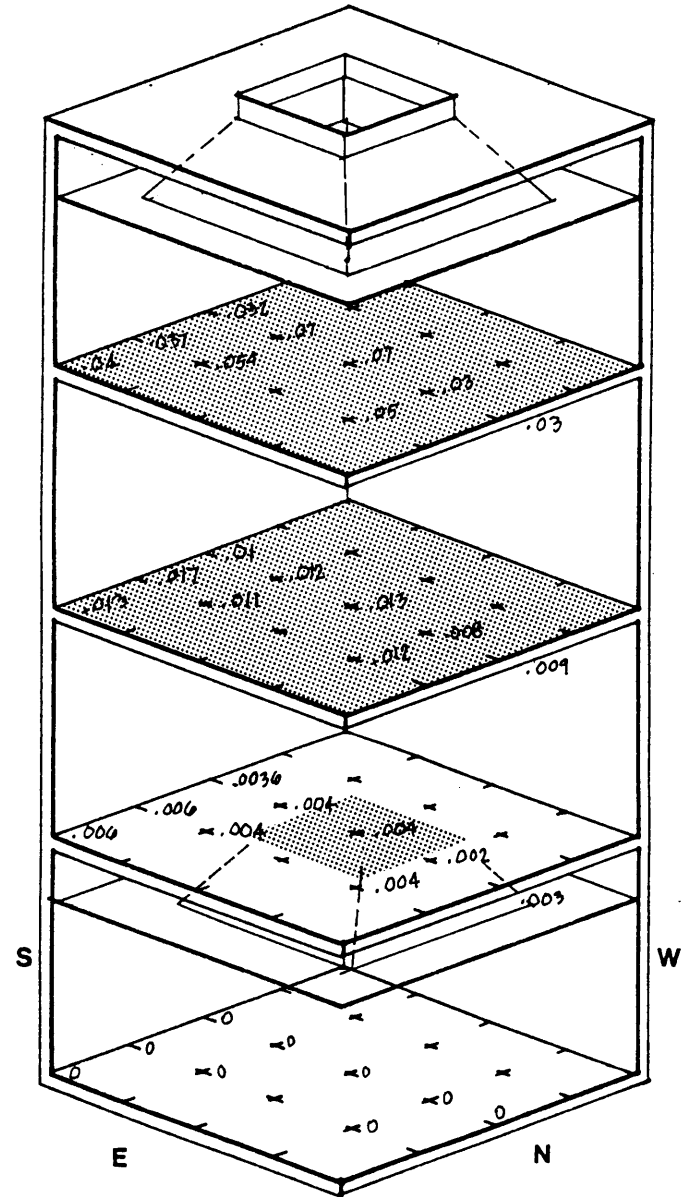

FLOOR LIGHT PHYSICAL MODELING TEST 12

SKY CONDITION: clear (shaded meters)
 TIME OF DAY: 1:50 PM

WALL	N	E	S	W
ORIENTATION				
SKYLIGHT SIZE=	6'-0"x 6'-0" T= 65%			
WALL				
REFLECT.	10%	100%	10%	10%
1ST FLOOR LIGHT SIZE=	16'-0"x 16'-0" T= 70%			
WALL				
REFLECT.	10%	100%	10%	10%
2ND FLOOR LIGHT SIZE=	16'-0"x 16'-0" T= 70%			
WALL				
REFLECT.	10%	100%	10%	10%
3RD FLOOR LIGHT SIZE=	16'-0"x 16'-0" T= 70%			
WALL				
REFLECT.	10%	100%	10%	10%
FLOOR REFLECTANCE=	45%			
(Typical all floors)				

	1ST	2ND	3RD	4TH
CEILING				
REFLECT.	70%	50%	50%	50%
CEILING				
HEIGHT=	8'-6"	11'-0"	11'-0"	11'-0"

REMARKS: Increased floor light aperture size on 3rd floor.
 Increased room cavity ratios and decreased wall reflectances.
 Good general lighting levels on 1st and 2nd floors with levels adequate for circulation and accessory spaces on 3rd floor.

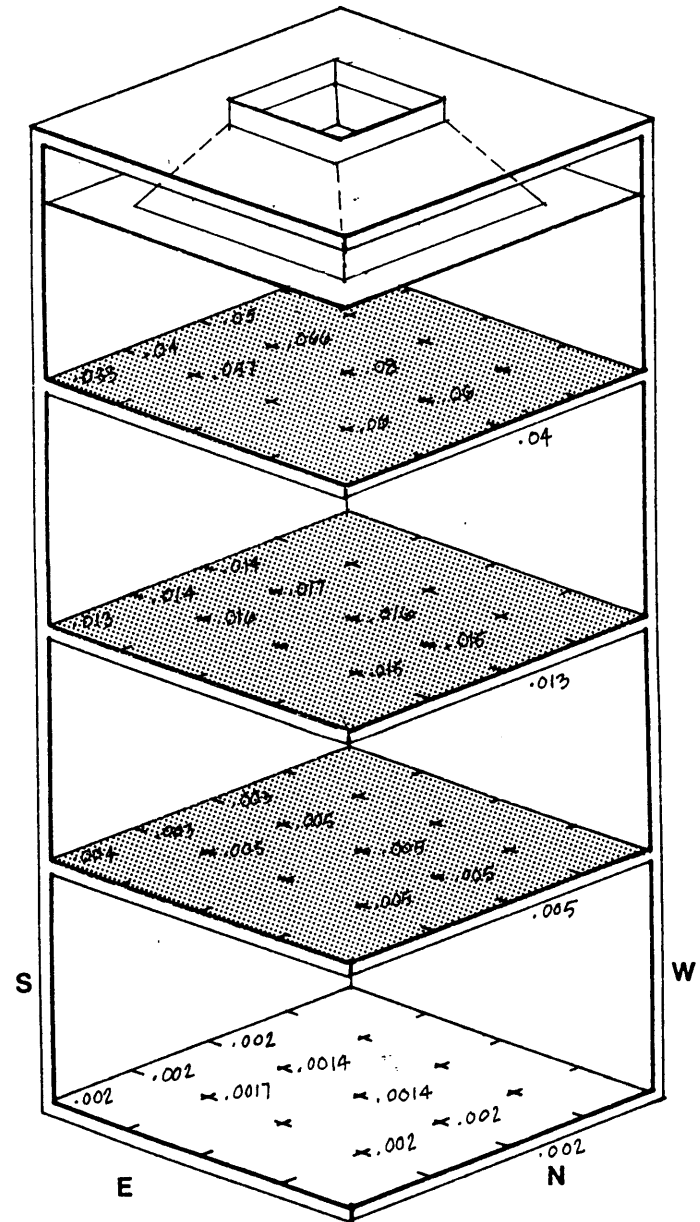

FLOOR LIGHT PHYSICAL MODELING TEST 13

SKY CONDITION: overcast
 TIME OF DAY: 2:30 PM

WALL N E S W
 ORIENTATION
 SKYLIGHT SIZE= 6'-0"x 6'-0" T=65%
 WALL
 REFLECT. 80% 80% 100% 80%
 1ST FLOOR LIGHT SIZE= 16'-0"x 16'-0" T=70%
 WALL
 REFLECT. 80% 80% 100% 80%
 2ND FLOOR LIGHT SIZE= 16'-0"x 16'-0" T=70%
 WALL
 REFLECT. 10% 80% 80% 80%
 3RD FLOOR LIGHT SIZE= 16'-0"x 16'-0" T=70%
 WALL
 REFLECT. 80% 80% 10% 10%
 FLOOR REFLECTANCE= 45%
 (Typical all floors)

	1ST	2ND	3RD	4TH
CEILING				
REFLECT.=	70%	50%	50%	50%
CEILING				
HEIGHT =	8'-6"	11'-0"	11'-0"	11'-0"

REMARKS: Increased floor light aperture on 3rd floor.
 Decreased room cavity ratio and increased wall reflectances.
 Good general lighting levels on 1st, 2nd and 3rd floors, with
 adequate levels for circulation and accessory spaces on 4th
 floor.

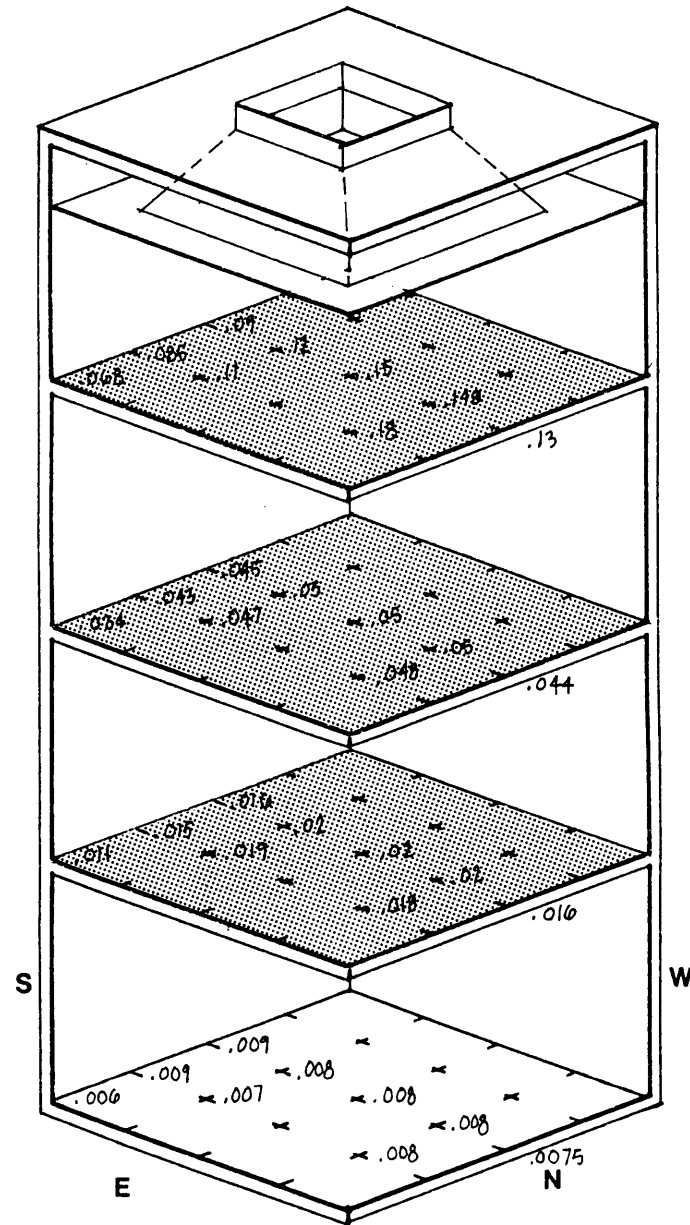

FLOOR LIGHT PHYSICAL MODELING TEST 14

SKY CONDITION: overcast 3000-4000 fc
 TIME OF DAY: 12:30 PM

WALL N E S W
 ORIENTATION

SKYLIGHT SIZE= 8'-0"x 8'-0" T=65%

WALL

REFLECT. 80% 80% 100% 80%

1ST FLOOR LIGHT SIZE= 6'-0"x 6'-0" T=50%

WALL

REFLECT. 80% 80% 100% 80%

2ND FLOOR LIGHT SIZE= 16'-0"x 16'-0" T=70%

WALL

REFLECT. 10% 80% 80% 80%

3RD FLOOR LIGHT SIZE= 16'-0"x 16'-0" T=70%

FLOOR REFLECTANCE= 45%

(Typical all floors)

	1ST	2ND	3RD	4TH
CEILING				
REFLECT.=	55%	70%	50%	50%
CEILING				
HEIGHT =	8'-6"	11'-0"	11'-0"	-

REMARKS: Increased skylight aperture. Increasing floor light apertures moving down from skylight. Room cavity ratios and wall reflectances remain the same as test 13.

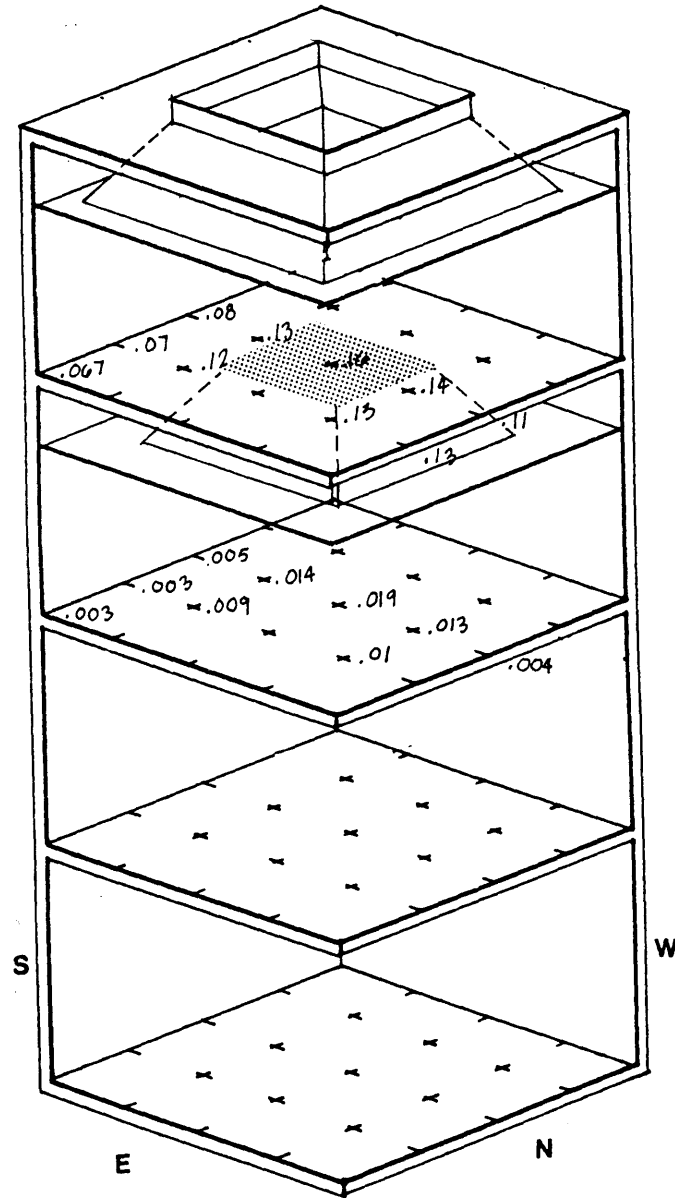

FLOOR LIGHT PHYSICAL MODELING TEST 14a

SKY CONDITION: overcast 2500-3000 fc
 TIME OF DAY: 11:00 AM

WALL	N	E	S	W
ORIENTATION				
SKYLIGHT SIZE=	8'-0"x8'-0" T=65%			
WALL				
REFLECT.	10%	10%	10%	10%
1ST FLOOR LIGHT SIZE=	6'-0"x 6'-0" T=50%			
WALL				
REFLECT.	80%	80%	80%	80%
2ND FLOOR LIGHT SIZE=	16'-0"x 16'-0" T=65%			
WALL	-	-	-	-
REFLECT.				
3RD FLOOR LIGHT SIZE=	-			

FLOOR REFLECTANCE= 45%
 (Typical all floors)

	1ST	2ND	3RD	4TH
CEILING				
REFLECT.=	55%	70%	-	-
CEILING				
HEIGHT =	8'-6"	8'-6"	-	-

REMARKS: Increased room cavity ratio on 1st floor.
 Decreased wall reflectances on 1st floor. Decreased room cavity ratio on 2nd floor.

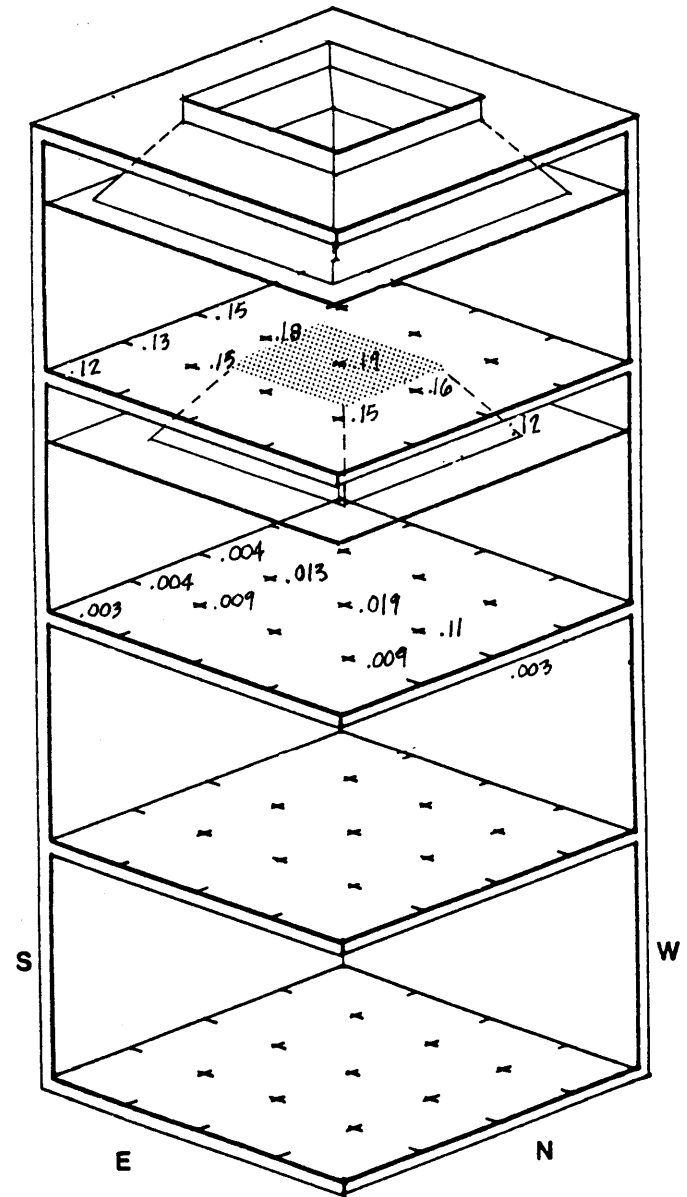

FLOOR LIGHT PHYSICAL MODELING TEST 15

SKY CONDITION: partly cloudy 2000-3500 fc
 TIME OF DAY: 2:10 PM

WALL N E S W
 ORIENTATION
 SKYLIGHT SIZE= 8'-0"x 8'-0" T=65%
 WALL
 REFLECT. 80% 100% 100% 10%
 1ST FLOOR LIGHT SIZE= 16'-0"x16'-0" T=70%
 WALL
 REFLECT. 80% 80% 80% 80
 2ND FLOOR LIGHT SIZE= 12'-0"x 12'-0" T= 60%
 WALL
 REFLECT: 80% 100% 100% 10%
 3RD FLOOR LIGHT SIZE= 6'-0"x 6'-0" T=50%

FLOOR REFLECTANCE= 45%
 (Typical all floors)

	1ST	2ND	3RD	4TH
CEILING				
REFLECT.=	70%	50%	50%	70%
CEILING				
HEIGHT	= 8'-6"	11'-0"	11'-0"	8'-6"

REMARKS: Increased floor light aperture on 1st floor.
 Decreased floor light apertures 2nd and 3rd floors as compared with test 14. Good general daylight levels on 1st and 2nd floor. Daylight levels on 3rd floor adequate for circulation and accessory spaces.

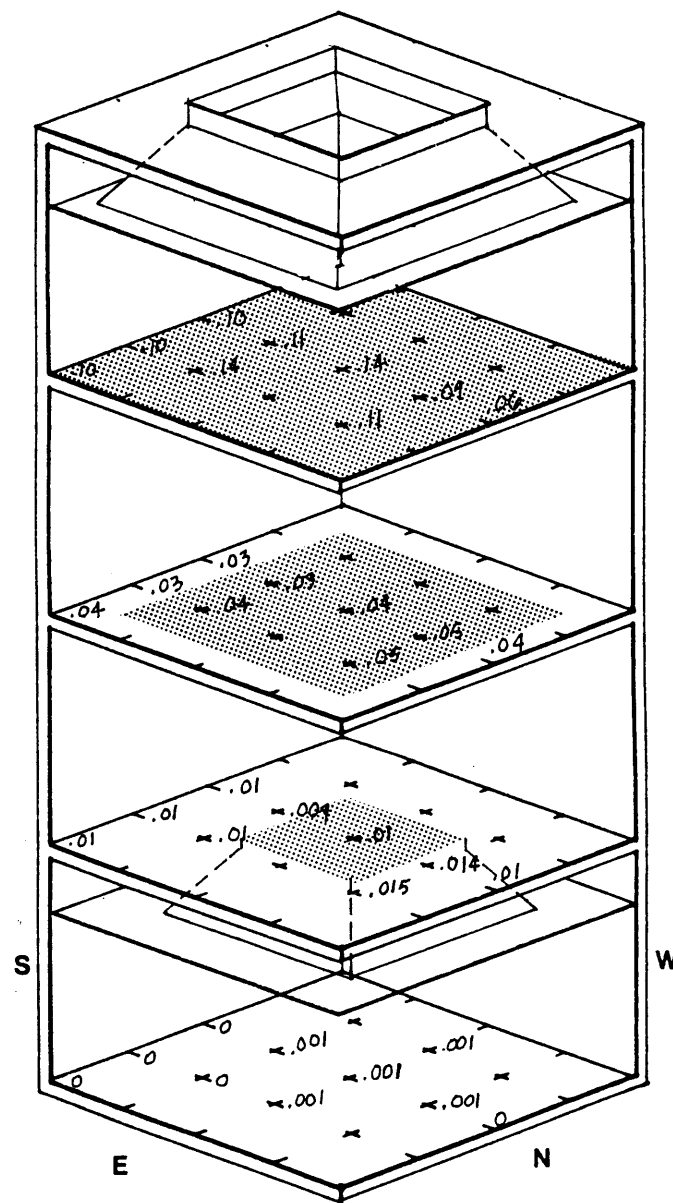

FLOOR LIGHT PHYSICAL MODELING TEST 16

SKY CONDITION: partly cloudy
 TIME OF DAY: 1:50 PM

WALL	N	E	S	W
ORIENTATION				
SKYLIGHT SIZE= 8'-0"x 8'-0" T=65%				
WALL				
REFLECT.	80%	80%	80%	80%
1ST FLOOR LIGHT SIZE= 16'-0"x16'-0" T=70%				
WALL				
REFLECT.	80%	80%	80%	80%
2ND FLOOR LIGHT SIZE= 12'-0"x 12'-0" T=65%				
WALL				
REFLECT.	80%	80%	80%	10%
3RD FLOOR LIGHT SIZE= 6'-0" x 6'-0" T=50%				
WALL				
REFLECT.	10%	80%	80%	10%
FLOOR REFLECTANCE= 45%				
(Typical all floors)				

	1ST	2ND	3RD	4TH
CEILING				
REFLECT.=	70%	50%	50%	70%
CEILING				
HEIGHT	= 8'-6"	11'-0"	11'-0"	8"-6"

REMARKS: Floor light apertures remain the same. Decreased room cavity ratios on 1st and 2nd floor. Wall reflectances remain the same except for 4th floor where they are increased. Generally good daylight levels on 1st and 2nd floor with adequate levels for circulation and accessory spaces on 3rd floor. Daylight levels on the 4th floor in both tests 14 and 15 are insufficient to make this floor light practical for daylighting reasons alone.

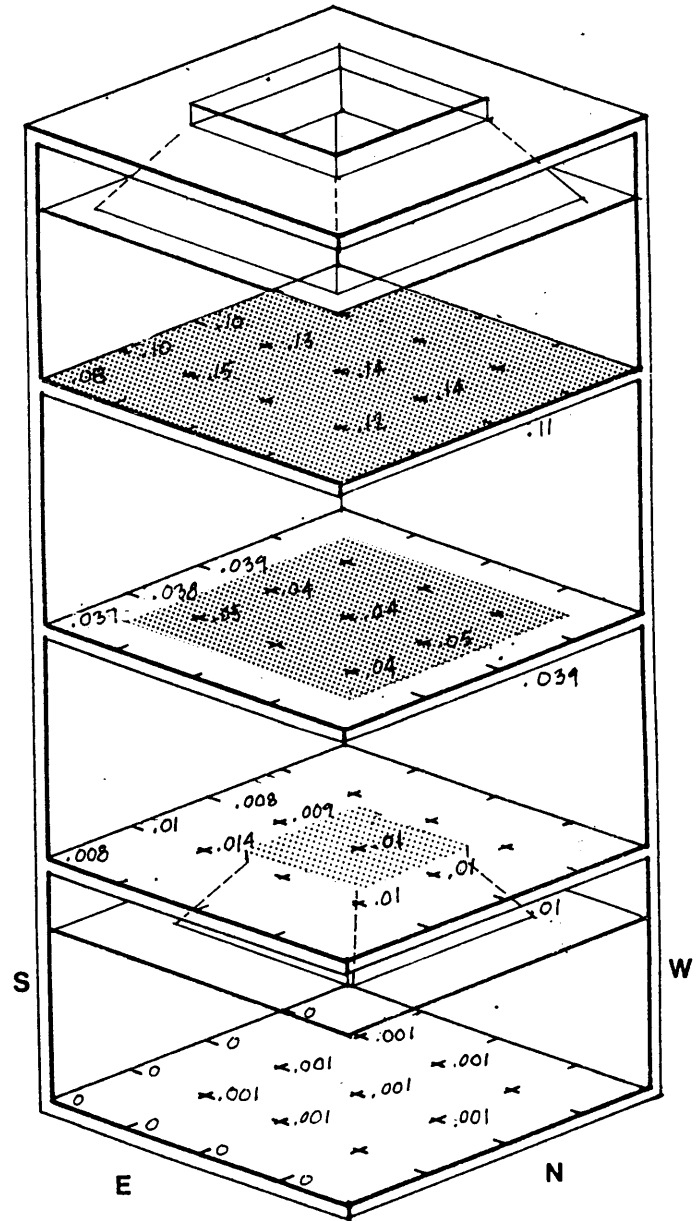

FLOOR LIGHT PHYSICAL MODELING TEST 17

SKY CONDITION: overcast 2500-3000 fc
 TIME OF DAY: 11:05 AM

WALL	N	E	S	W
ORIENTATION				
SKYLIGHT SIZE= 8'-0"x 8'-0" T=65%				
WALL				
REFLECT.	80%	80%	100%	80%
1ST FLOOR LIGHT SIZE= 16'-0"x 16'-0" T=70%				
WALL				
REFLECT.	80%	80%	100%	80%
2ND FLOOR LIGHT SIZE= 16'-0"x 16'-0" T=70%				
WALL				
REFLECT.	10%	80%	80%	80%
3RD FLOOR LIGHT SIZE= 16'-0"x16'-0" T=70%				
WALL				
REFLECT.	10%	80%	100%	80%
FLOOR REFLECTANCE= 45%				
(Typical all floors)				

	1ST	2ND	3RD	4TH
CEILING				
REFLECT.=	70%	50%	50%	50%
CEILING				
HEIGHT=	8'-6"	11'-0"	11'-0"	11'-0"

REMARKS: Increased floor light apertures on 2nd and 3rd floors. Room cavity ratios and wall reflectances similar to test 14. Good general daylighting levels on 1st, 2nd and, 3rd floors. Adequate levels on 4th floor for circulation and accessory spaces.

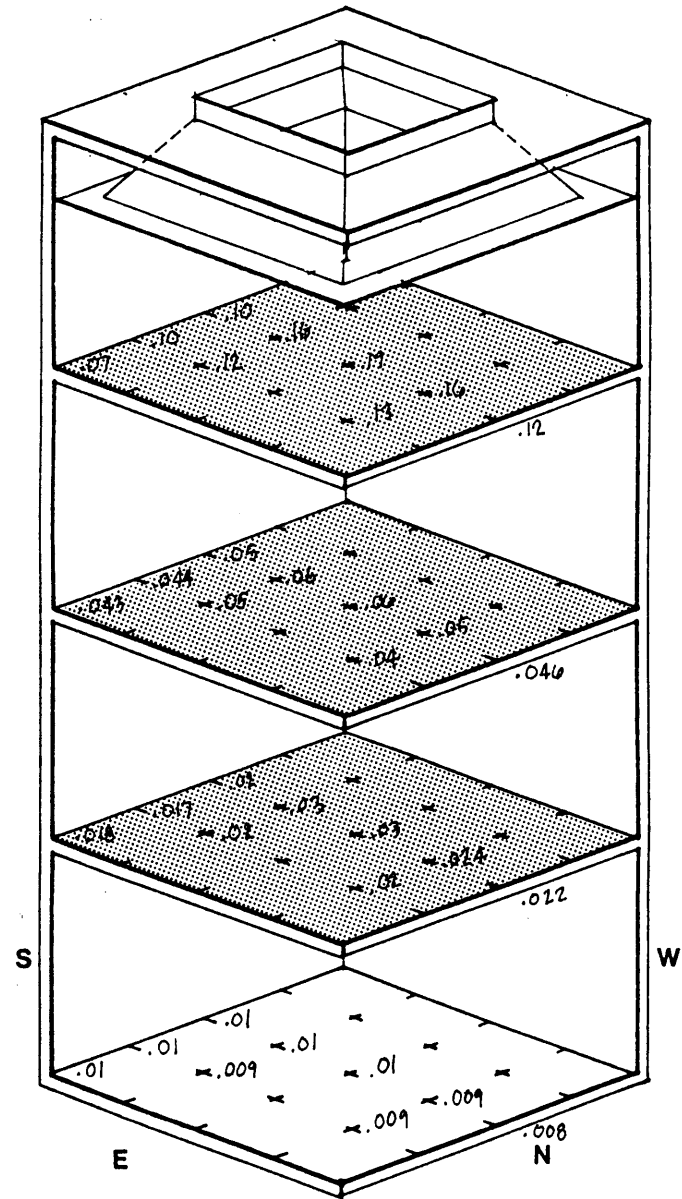

FLOOR LIGHT PHYSICAL MODELING TEST 18

SKY CONDITION: overcast 2500-3000 fc
 TIME OF DAY: 2:40 PM

WALL	N	E	S	W
ORIENTATION				
SKYLIGHT SIZE=	12'-0"x	12'-0"	T=65%	
WALL				
REFLECT.	80%	80%	80%	80%
1ST FLOOR LIGHT SIZE=	6'-0"x	6'-0"	T=50%	
WALL				
REFLECT.	80%	80%	80%	80%
2ND FLOOR LIGHT SIZE=	2'-0"x	2'-0"	T=75%	
WALL				
REFLECT.	-	-	-	-
3RD FLOOR LIGHT SIZE=	none			

FLOOR REFLECTANCE= 45%
 (Typical all floors)

	1ST	2ND	3RD	4TH
CEILING				
REFLECT.=	30%	70%	-	-
CEILING				
HEIGHT=	8'-6"	8'-6"	-	-

REMARKS: Decreased floor light apertures on 1st and 2nd floor. Wall reflectances and room cavity ratios remain the same. Good daylight levels on 1st floor. Daylight levels on 2nd floor adequate for circulation and accessory spaces only.

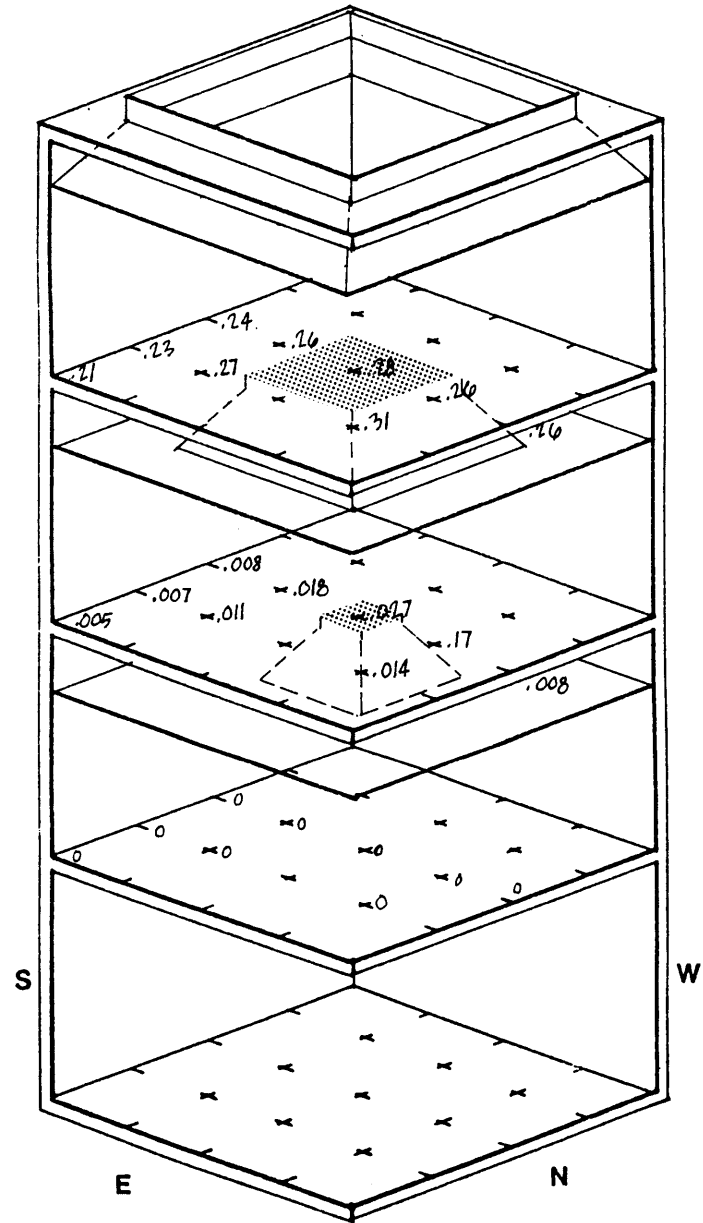

FLOOR LIGHT PHYSICAL MODELING

TEST 19

SKY CONDITION: overcast 2000-2500 fc
 TIME OF DAY: 3:05 PM

WALL N E S W
 ORIENTATION
 SKYLIGHT SIZE= 12'-0"x 12'-0" T=65%
 WALL
 REFLECT. 80% 80% 80% 80%
 1ST FLOOR LIGHT SIZE= 12'-0"x 12'-0" T=70%
 WALL
 REFLECT. 80% 80% 80% 80%
 2ND FLOOR LIGHT SIZE= 6'-0"x 6'-0" T=50%
 WALL
 REFLECT. 10% 10% 10% 10%
 3RD FLOOR LIGHT SIZE= 2'-0"x 2'-0" T=75%
 WALL
 REFLECT. - - - -
 FLOOR REFLECTANCE= 45%
 (Typical all floors)

	1ST	2ND	3RD	4TH
CEILING				
REFLECT.=	30%	50%	70%	75%
CEILING				
HEIGHT=	8'-6"	11'-0"	11'-0"	8'-6"

REMARKS: Increased skylight aperture. Decreased floor light apertures on 1st, 2nd and 3rd floors. Wall reflectances similar to test 17 with decreased room cavity ratios on 1st and 2nd floor. Good daylighting levels on 1st and 2nd floor with insufficient levels on the 3rd and 4th floors.

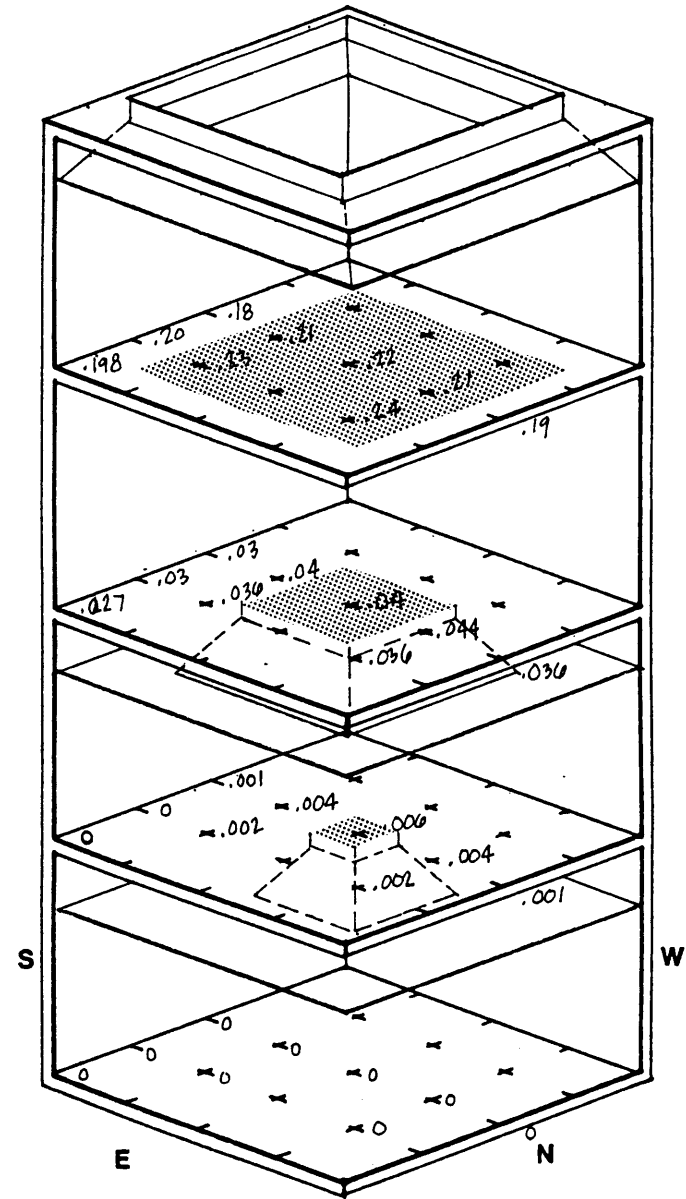

FLOOR LIGHT PHYSICAL MODELING

TEST 20

SKY CONDITION: overcast (2500-2700 fc)
 TIME OF DAY: 3:20 PM

WALL N E S W
 ORIENTATION

SKYLIGHT SIZE= 12'-0"x 12'-0" T=65%

WALL
 REFLECT. 80% 80% 80% 80%

1ST FLOOR LIGHT SIZE= 12'-0"x 12'-0" T=65%

WALL
 REFLECT. 80% 80% 80% 80%

2ND FLOOR LIGHT SIZE= 6'-0"x 6'-0" T=50%

WALL
 REFLECT. 80% 100% 100% 10%

3RD FLOOR LIGHT SIZE= 2'-0"x 2'-0" T=65%

WALL
 REFLECT. 80% 80% 80% 10%

FLOOR REFLECTANCE= 45%

(Typical all floors)

	1ST	2ND	3RD	4TH
CEILING				
REFLECT.=	30%	50%	70%	75%
CEILING				
HEIGHT=	8'-6"	11'-0"	8'-6"	8'-6"

REMARKS: Floor light and skylight apertures remain the same. Decreased room cavity ratio and increased wall reflectances on 3rd and 4th floor. Good daylighting levels on 1st and 2nd floor while despite the increased wall reflectances and reduced room cavity ratio, daylight levels are still insufficient on the 3rd and 4th floor.

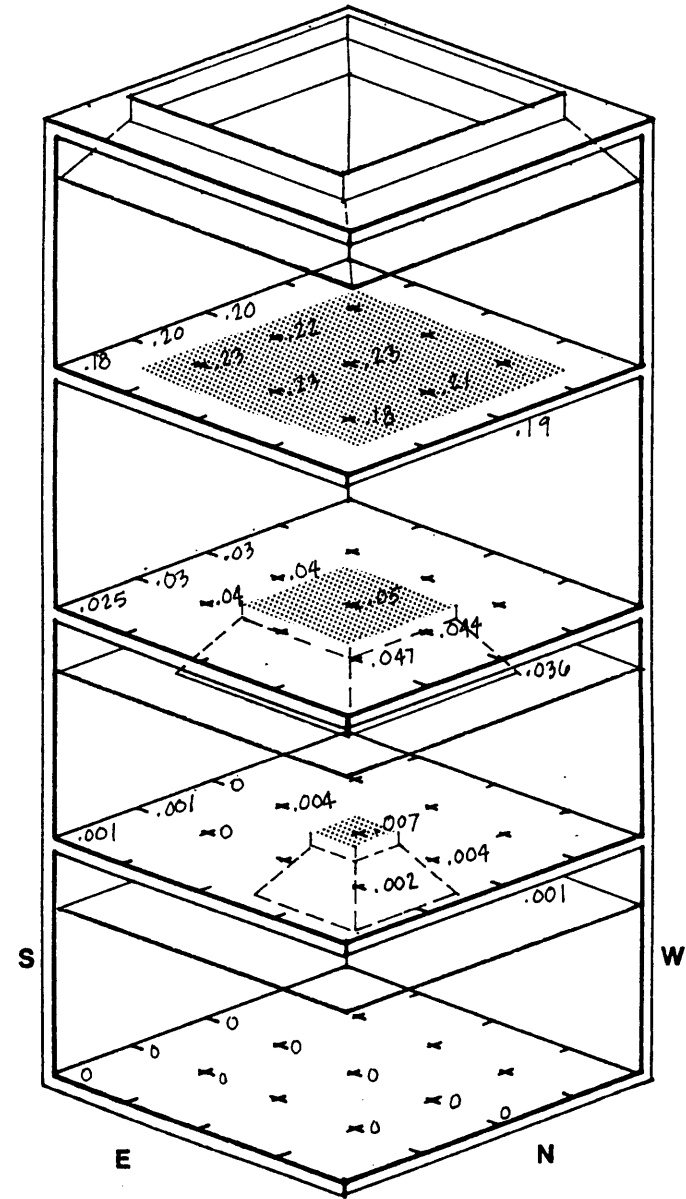

FLOOR LIGHT PHYSICAL MODELING TEST 21

SKY CONDITION: overcast 1200-1400 fc
 TIME OF DAY: 3:50 PM

WALL N E S W
 ORIENTATION

SKYLIGHT SIZE= 12'-0" x 12'-0" T=65%

WALL

REFLECT. 80% 80% 80% 80%

1ST FLOOR LIGHT SIZE= 12'-0" x 12'-0" T=65%

WALL

REFLECT. 80% 80% 80% 80%

2ND FLOOR LIGHT SIZE= 6'-0" x 6'-0" T=50%

WALL

REFLECT. 10% 10% 10% 10%

3RD FLOOR LIGHT SIZE= 6'-0" x 6'-0" T=50%

WALL

REFLECT. 10% 10% 10% 10%

FLOOR REFLECTANCE= 45%

(Typical all floors)

	1ST	2ND	3RD	4TH
CEILING				
REFLECT.=	30%	50%	70%	70%
CEILING				
HEIGHT=	8'-6"	11'-0"	8'-6"	8'-6"

REMARKS: Increased floorlight aperture on 3rd floor.
 Room cavity ratios and wall reflectances the same as test 18.
 Good daylight levels on 1st and 2nd floor while daylight
 levels on 3rd and 4th are insufficient despite increased
 floorlight on 3rd floor.

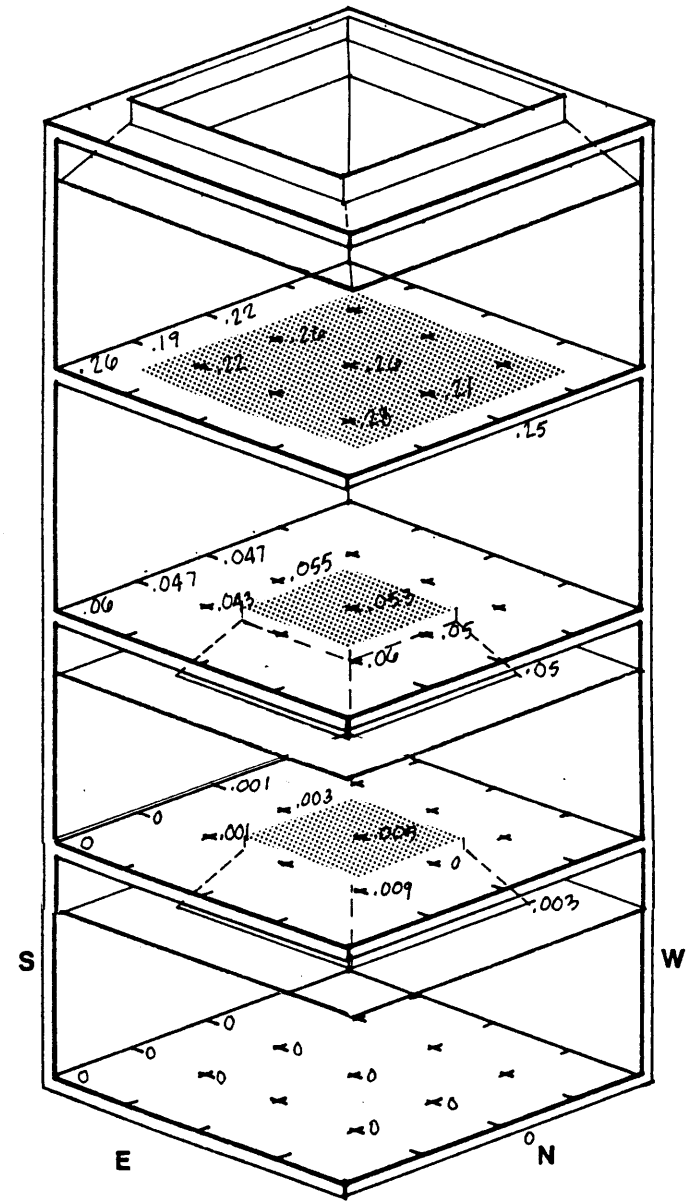

FLOOR LIGHT PHYSICAL MODELING TEST 22

SKY CONDITION: overcast 1000 fc
 TIME OF DAY: 4:00 PM

WALL	N	E	S	W
ORIENTATION				
SKYLIGHT SIZE= 12'-0"x 12'-0" T=65%				
WALL				
REFLECT.	10%	10%	10%	10%
1ST FLOOR LIGHT SIZE= 16'-0"x 16'-0" T=70%				
WALL				
REFLECT.	10%	10%	10%	10%
2ND FLOOR LIGHT SIZE= 12'-0"x 12'-0" T=65%				
WALL				
REFLECT.	10%	10%	10%	10%
3RD FLOOR LIGHT SIZE= 6'-0"x 6'-0" T=50%				
WALL				
REFLECT.	10%	10%	10%	10%
FLOOR REFLECTANCE= 45%				
(Typical all floors)				

	1ST	2ND	3RD	4TH
CEILING				
REFLECT.=	30%	50%	50%	70%
CEILING				
HEIGHT=	8'-6"	11'-0"	11'-0"	8'-6"

REMARKS: Increased floor light apertures on 1st, 2nd and 3rd floors. Decreased wall reflectances and increase room cavity ratios. Good daylight levels on 1st and 2nd floors while levels on 3rd floor are adequate for circulation only and 4th floor levels are insufficient.

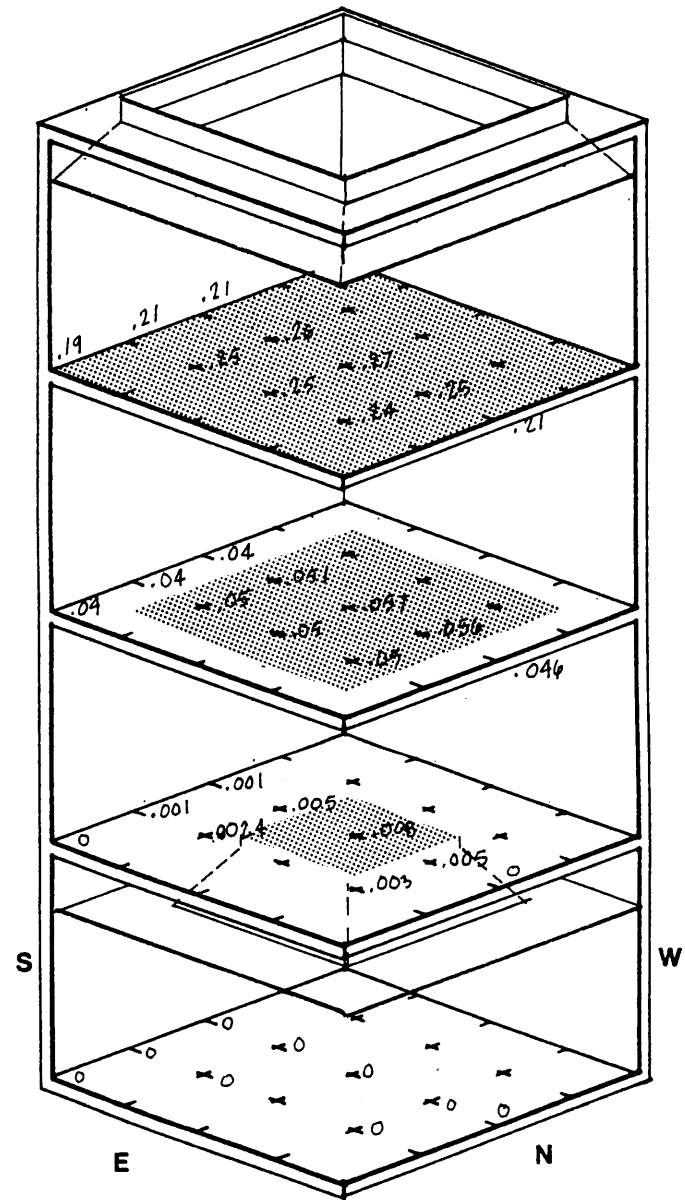

FLOOR LIGHT PHYSICAL MODELING TEST 23

SKY CONDITION: overcast 2000-2500 fc
 TIME OF DAY: 10:30 AM

WALL	N	E	S	W
ORIENTATION				
SKYLIGHT SIZE=	12'-0"x 12'-0" T=65%			
WALL				
REFLECT.	80%	80%	100%	80%
1ST FLOOR LIGHT SIZE=	16'-0"x16'-0" T=70%			
WALL				
REFLECT.	80%	80%	100%	80%
2ND FLOOR LIGHT SIZE=	16'-0"x 16'-0" T=70%			
WALL				
REFLECT.	80%	80%	10%	10%
3RD FLOOR LIGHT SIZE=	16'-0"x 16'-0" T=70%			
WALL				
REFLECT.	80%	80%	100%	10%
FLOOR REFLECTANCE=	45%			
(Typical all floors)				

	1ST	2ND	3RD	4TH
CEILING				
REFLECT.=	30%	50%	50%	50%
CEILING				
HEIGHT=	8'-6"	11'-0"	11'-0"	11'-0"

REMARKS: Increased floor light apertures on 2nd and 3rd floor. Decreased room cavity ratios and increased wall reflectances. Combination results in good daylight levels on 1st, 2nd and 3rd floors while the levels on the 4th floor are adequate for circulation.

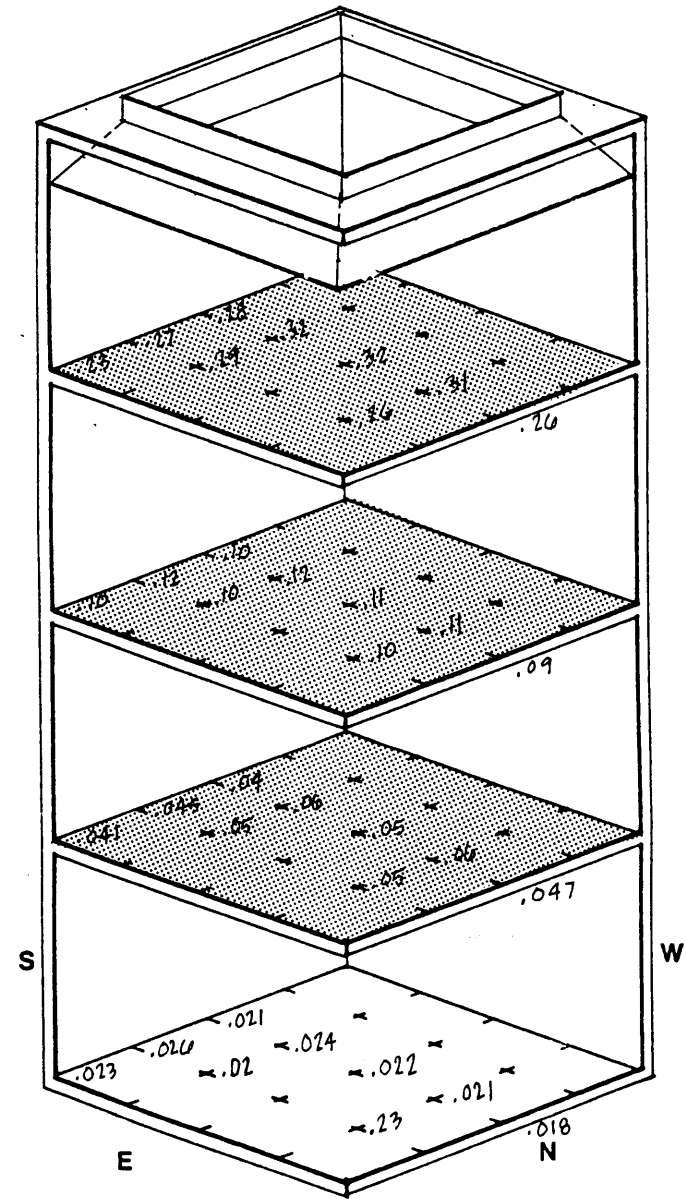

FLOOR LIGHT PHYSICAL MODELING

TEST 24

SKY CONDITION: clear (shaded meters) 1200 fc
 TIME OF DAY: 3:15 PM

WALL	N	E	S	W
ORIENTATION				
SKYLIGHT SIZE= 12'-0"x 12'-0" T=65%				
WALL				
REFLECT.	80%	80%	80%	80%
1ST FLOOR LIGHT SIZE= 16'-0"x16'-0" T=70%				
WALL				
REFLECT.	80%	80%	100%	80%
2ND FLOOR LIGHT SIZE= 16'-0"x 16'-0" T=70%				
WALL				
REFLECT.	80%	80%	10%	10%
3RD FLOOR LIGHT SIZE= 16'-0"x 16'-0" T=70%				
WALL				
REFLECT.	80%	80%	100%	10%
FLOOR REFLECTANCE= 45%				
(Typical all floors)				

	1ST	2ND	3RD	4TH
CEILING				
REFLECT.=	70%	50%	50%	50%
CEILING				
HEIGHT =	8'-6"	11'-0"	11'-0"	11'-0"

REMARKS: All apertures, wall reflectances and room cavity ratios are similar to test 23. The only factor that is varied in this case is the type of daylight entering the model. Daylight levels still remain good for the 1st, 2nd and 3rd floors, but there is a substantial drop in daylight factors throughout the model resulting from the different properties of clear and overcast sky conditions as discussed in chapter 2.

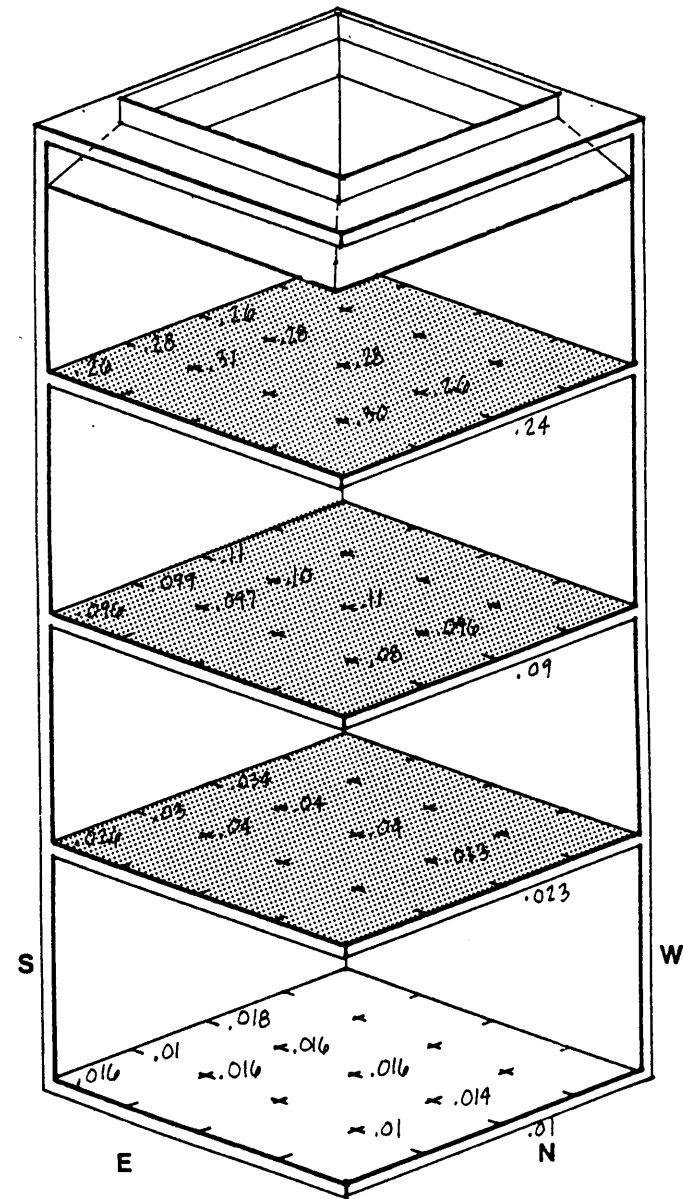

FLOOR LIGHT PHYSICAL MODELING TEST 25

SKY CONDITION: overcast 1400 fc
 TIME OF DAY: 3:05 PM

WALL	N	E	S	W
ORIENTATION				
SKYLIGHT SIZE=	12'-0"x12'-0" T=65%			
WALL				
REFLECT.	80%	10%	80%	80%
1ST FLOOR LIGHT SIZE=	4- 3'-0"x 3'-0" T=70%			
WALL				
REFLECT.	80%	10%	80%	80%
2ND FLOOR LIGHT SIZE=	4- 3'-0"x 3'-0" T=70%			
WALL				
REFLECT.	10%	10%	10%	10%
3RD FLOOR LIGHT SIZE=	16'-0"x 16'-0" T=70%			
WALL				
REFLECT.	10%	10%	10%	10%
FLOOR REFLECTANCE=	45%			
(Typical all floors)				

	1ST	2ND	3RD	4TH
CEILING				
REFLECT.=	30%	70%	70%	50%
CEILING				
HEIGHT =	8'-6"	11'-0"	11'-0"	11'-0"

REMARKS: Break floor light in test 18 down in to four smaller floor lights of an equal area on 1st and 2nd floors. Wall reflectances and room cavity ratios similar to test 18. Good general daylight levels on 1st and 2nd floor with a more equal distribution through out the room.

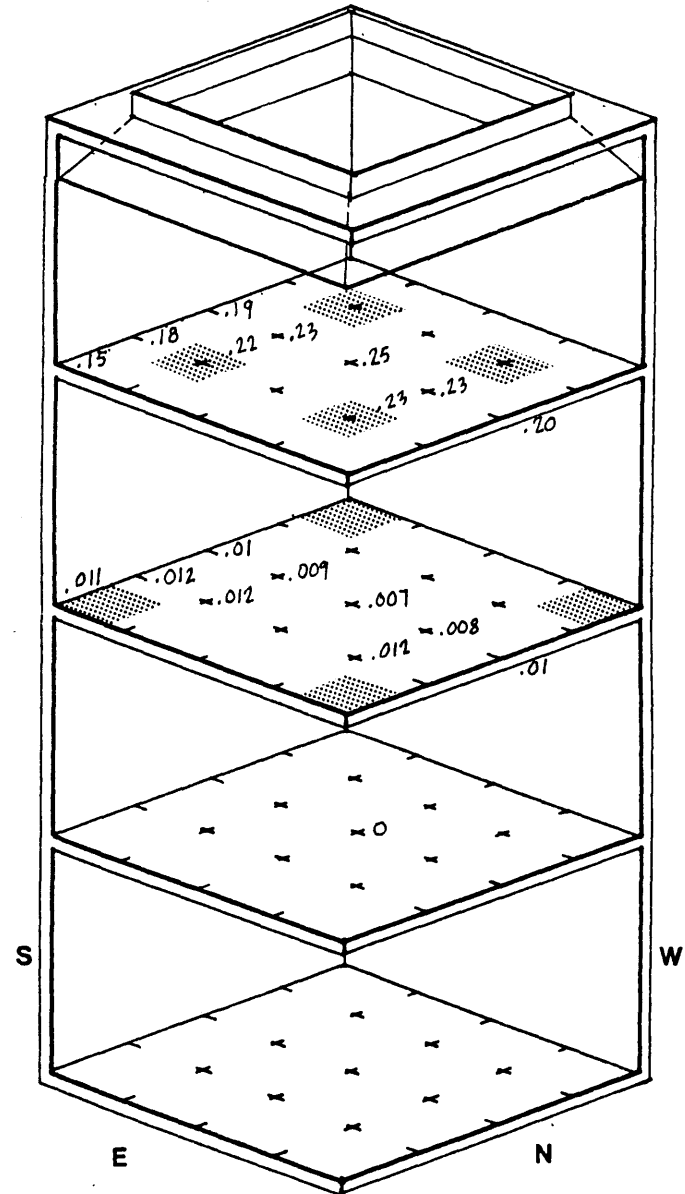

FLOOR LIGHT PHYSICAL MODELING TEST 26

SKY CONDITION: overcast 2000 fc
 TIME OF DAY: 3:10

WALL	N	E	S	W
ORIENTATION				
SKYLIGHT SIZE= 12'-0"x 12'-0" T=65%				
WALL				
REFLECT.	80%	80%	100%	100%
1ST FLOOR LIGHT SIZE= 4- 3'-0"x 3'-0" T=70%				
WALL				
REFLECT.	80%	80%	100%	100%
2ND FLOOR LIGHT SIZE= 4- 3'-0"x 3'-0" T=70%				
WALL				
REFLECT.	80%	80%	80%	80%
3RD FLOOR LIGHT SIZE= --				
WALL				
REFLECT.	-	-	-	-
FLOOR REFLECTANCE= 45%				
(Typical all floors)				

	1ST	2ND	3RD	4TH
CEILING				
REFLECT.=	30%	70%	70%	-
CEILING				
HEIGHT =	8'-6"	11'-0"	11'-0"	-

REMARKS: Increased room cavity ratio and wall reflectances. Skylight and floor light apertures remain the same. Good general daylight levels on 1st and 2nd floor with a more equal distribution of daylight and elimination of dark corners. Daylight levels on 3rd floor are insufficient to justify floor lights in 2nd floor.

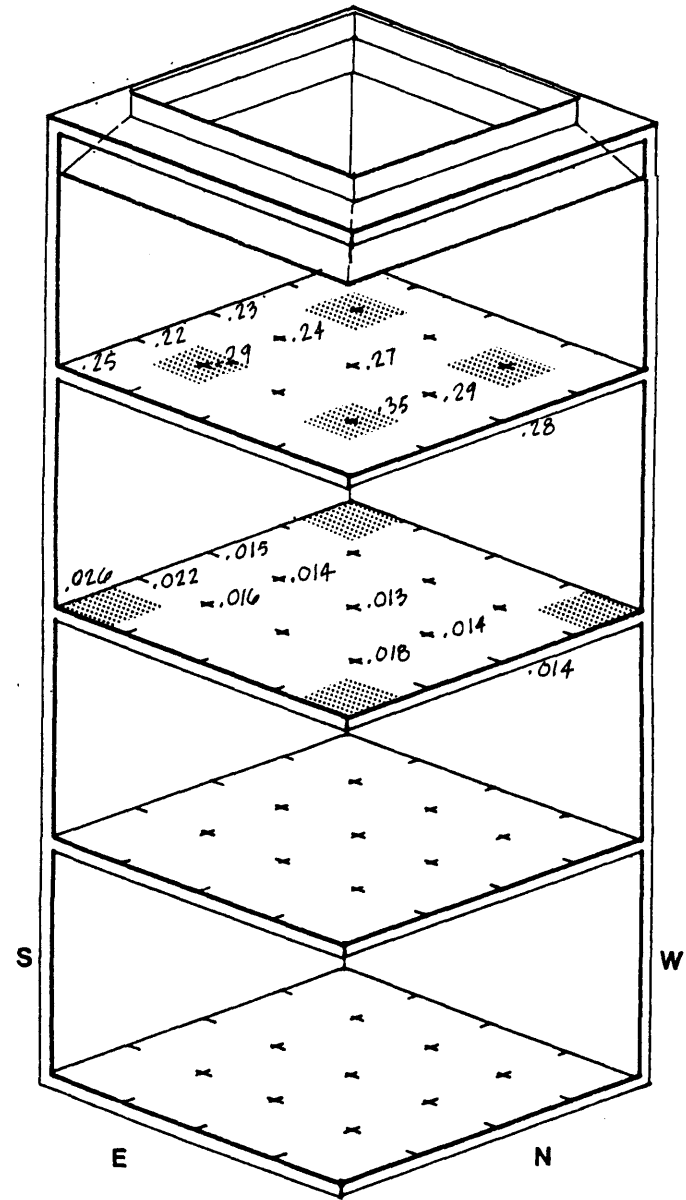

FLOOR LIGHT PHYSICAL MODELING TEST 27

SKY CONDITION: overcast 1650fc
 TIME OF DAY: 3:15 PM

WALL N E S W
 ORIENTATION

SKYLIGHT SIZE= 16'-0"x 16'-0" T=65%

WALL

REFLECT. 80% 80% 100% 100%

1ST FLOOR LIGHT SIZE= 4- 3'-0"x 3'-0" T=65%

WALL

REFLECT. 80% 80% 100% 100%

2ND FLOOR LIGHT SIZE= 4- 3'-0"x 3'-0" T=65%

WALL

REFLECT. 80% 80% 80% 80%

3RD FLOOR LIGHT SIZE= --

WALL

REFLECT. - - - -

FLOOR REFLECTANCE= 45%

(Typical all floors)

	1ST	2ND	3RD	4TH
CEILING				
REFLECT.=	0%	70%	70%	70%
CEILING				
HEIGHT =	12'-0"	11'-0"	11'-0"	-

REMARKS: Increased skylight aperture. Wall reflectances and room cavity ratios remain the same as test 27. This combination results in a fairly even daylight distribution, however the levels may only be adequate for circulation and other accessory spaces on the 2nd floor and insufficient on the 3rd floor.

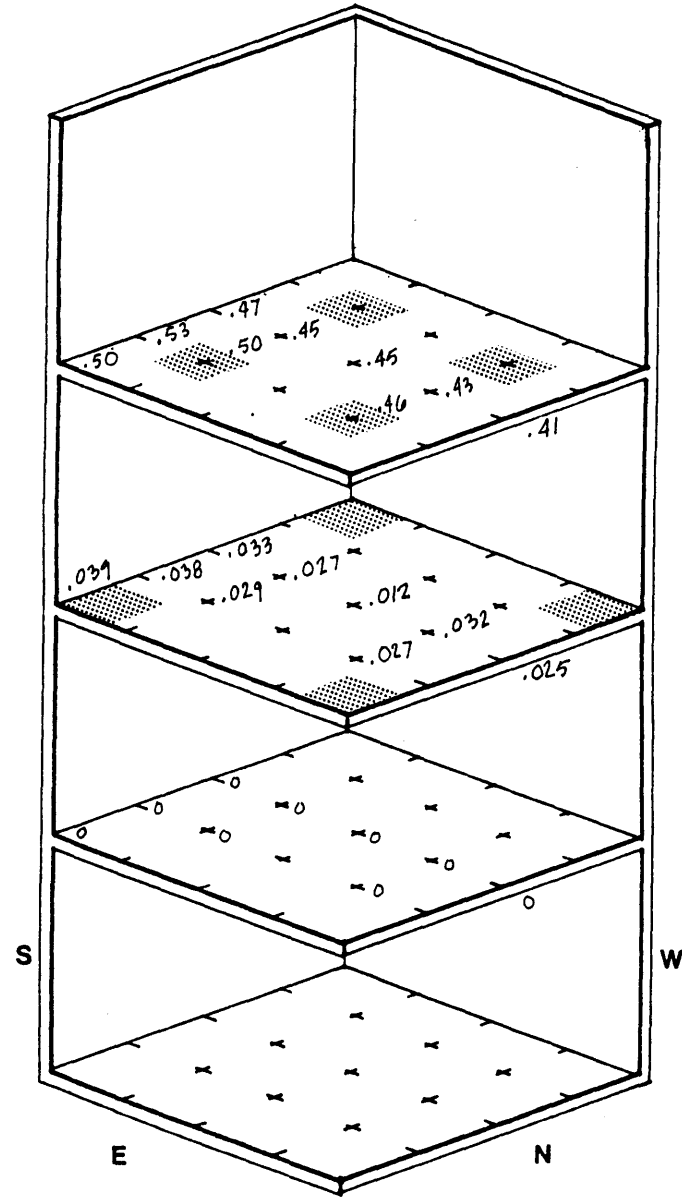

FLOOR LIGHT PHYSICAL MODELING TEST 28

SKY CONDITION: overcast 1100 fc
 TIME OF DAY: 3:40 PM

WALL N E S W
 ORIENTATION
 SKYLIGHT SIZE= 16'-0"x 16'-0" T=65%
 WALL
 REFLECT. 80% 80% 100% 100%
 1ST FLOOR LIGHT SIZE= 16'-0"x 16'-0" T=70%
 WALL
 REFLECT. 80% 80% 100% 100%
 2ND FLOOR LIGHT SIZE= 16'-0"x 16'-0" T=70%
 WALL
 REFLECT. 80% 80% 10% 10%
 3RD FLOOR LIGHT SIZE= 16'-0"x16'-0" T=70%
 WALL
 REFLECT. 80% 80% 100% 10%
 FLOOR REFLECTANCE= 45%
 (Typical all floors)

	1ST	2ND	3RD	4TH
CEILING				
REFLECT. =	0%	50%	50%	50%
CEILING				
HEIGHT =	12'-0"	11'-0"	11'-0"	11'-0"

REMARKS: Skylight and floor light apertures, wall reflectances and room cavity ratios are similar to test 27. This combination investigates the effect of obstructing furniture and occupants placed on the 1st floor light to daylight levels throughout the model. This combination results in good general daylight levels on the 1st, 2nd and 3rd floors with levels adequate for circulation and accessory spaces on the 4th floor. Although the occupants and furniture appear to have an immediate effect on the 1st floor daylight levels, this effect seems to be more evenly distributed as the number of intervening floors increases.

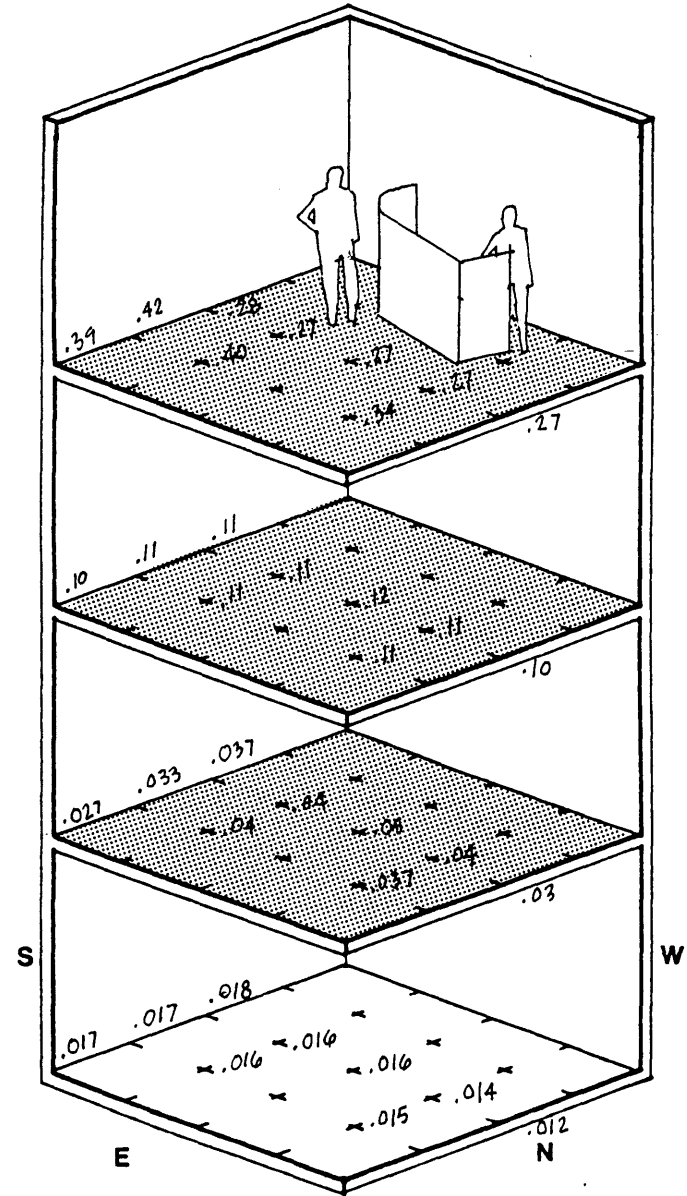

FLOOR LIGHT PHYSICAL MODELING TEST 29

SKY CONDITION: overcast 2000-2500 fc
 TIME OF DAY: 10:50 AM

WALL	N	E	S	W
ORIENTATION				
SKYLIGHT SIZE=	16'-0"x 16'-0" T=65%			
WALL				
REFLECT.	80%	80%	100%	80%
1ST FLOOR LIGHT SIZE=	16'-0"x16'-0" T=70%			
WALL				
REFLECT.	80%	80%	100%	80%
2ND FLOOR LIGHT SIZE=	16'-0"x 16'-0" T=70%			
WALL				
REFLECT.	80%	80%	10%	10%
3RD FLOOR LIGHT SIZE=	16'-0"x 16'-0" T=70%			
WALL				
REFLECT.	80%	80%	100%	10%
FLOOR REFLECTANCE=	45%			
(Typical all floors)				

	1ST	2ND	3RD	4TH
CEILING				
REFLECT.=	30%	50%	50%	50%
CEILING				
HEIGHT=	8'-6"	11'-0"	11'-0"	11'-0"

REMARKS: Increased skylight aperture. Wall reflectances and room cavity ratios remain the same as test 23 and 24. This combination of skylight and floor light apertures, wall reflectances and room cavity ratios represents the highest daylight levels encountered during testing. This combination offers good daylight levels on all four floors!

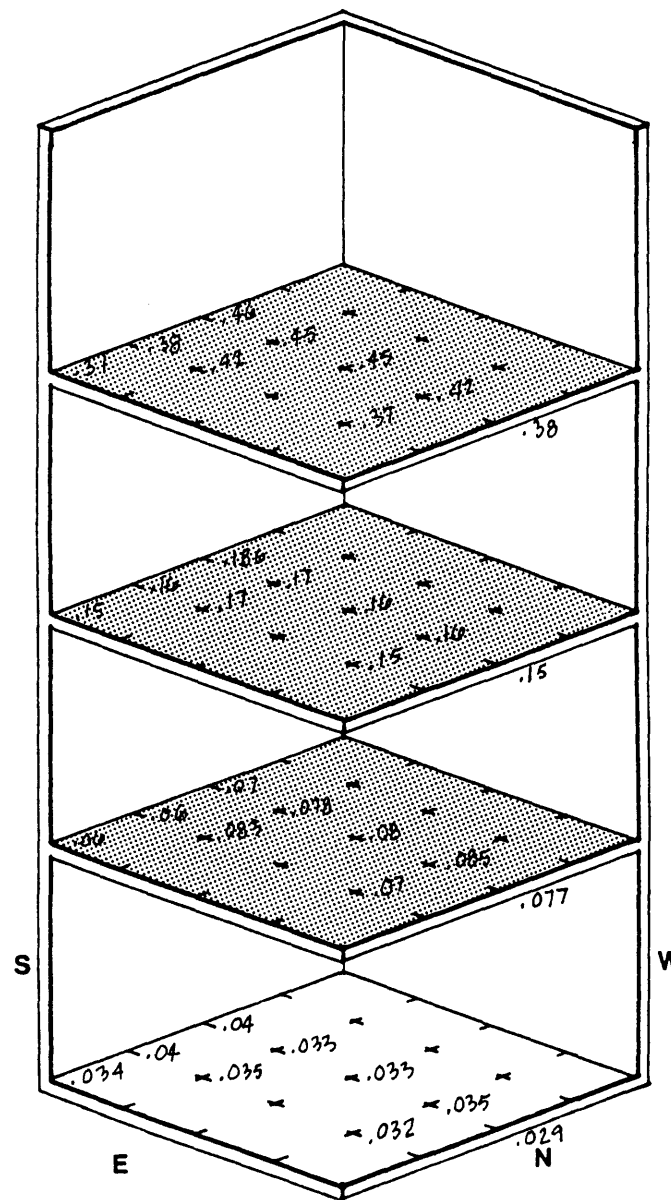

BIBLIOGRAPHY

1. Gloag, John. "The Place of Glass in Building," (London:George Allen and Unwin Ltd.) 1943.
2. Peter, John. "Design With Glass," (New York:Reinhold Publishing Corp.) 1964.
- 3 McGrath, Raymond and Frost, A.C. "Glass in Architecture and Decoration," (London: The Architectural Press.) 1937.
4. Stein, Richard. "Energy and Architecture," (New York: Anchor Press/ Doubleday.) 1977.
5. Eberlein, Harold and Hubbard, Cortland. "Glass in Modern Construction," (New York: Charles Scribner's Sons,) 1937.
6. Gloag, John. "A History of Cast Iron in Architecture," (London: W.S. Cowell Ltd.,) 1948.
7. Evans, Benjamin. "Daylight in Architecture," (New York: McGraw-Hill Book Co.,) 1981.
8. Egan, M. David. "Concepts in Architectural Lighting," (New York: McGraw Hill Book Co.,) 1983.
9. Mantero, Enrico. "Giuseppe Terragni e la Citta del Razionalismo Italiano," Dedalo Libri, 1969
10. Whyte, Iain Boyd. "Bruno Taut and the Architecture of Activism," (Cambridge: Cambridge University Press,) 1982.
11. Malamuceanu, Roland. "Atrium House Solar Revitalization," S.M.ArchS. Thesis, M.I.T., Department of Architecture, Cambridge, Ma. 1984.
12. Bartovics, William A., "The Thermal Performance of Fixed and Variable Selective Transmitters in Commercial Architecture," S.M.Arch.S. Thesis, M.I.T., Department of Architecture, Cambridge, MA, 1984.