

C/58-17

**ANALOG SIMULATION OF AN ECONOMY BEGINNING TO DEVELOP**

by

**Edward Peck Holland**

A paper to be presented at the Econometric Society meetings in Cambridge, Massachusetts, August 26-28, 1958.

**Center for International Studies  
Massachusetts Institute of Technology  
Cambridge, Massachusetts  
August, 1958**

## ANALOG SIMULATION OF AN ECONOMY BEGINNING TO DEVELOP

Economists work under a handicap. Aeronautical engineers have wind tunnels; psychologists have white rats and chimpanzees; but economists have no handy way of exploring their problems by trial and error in a laboratory. This is a grave handicap for policy formulation and needs to be offset by as good a substitute as can be found. One substitute is mathematical models. This helps us find out what kind of relationships could account for observed behavior and helps us draw inferences. However, many phenomena that have been recognized and described verbally have been omitted from such models, or have been studied only in isolation from the systems to which they belong, because they involve nonlinearities and other features that interfere with direct mathematical solution. A method of manipulating models which holds great promise for overcoming some of these difficulties is simulation by means of analogs. This paper concerns a pilot project which was recently done to gain experience with this technique. It was done on the large general-purpose analog of M.I.T.'s Dynamic Analysis & Control Laboratory, which was originally designed for simulating aircraft flight dynamics, and has been used on many other problems as well.

The paper will first describe and illustrate the basic principles of using analogs for simulation, but without going into the electronics

of the components. Then the economic system which was simulated will be described. After that, the results of a sample run will be shown and discussed.

#### ANALOG SIMULATION TECHNIQUE

Analog simulation is basically a matter of making a laboratory setup which will act out processes analogous to those to be studied, and then observing it while it acts them out under many different conditions.

With general purpose analogs, like ours, parameters of the system can be changed by turning knobs, and the basic structure can be altered by plugging in different units or rearranging connecting wires. The behavior is recorded, in our setup, as graphical time-histories of twelve selected variables. (If we want more than twelve, we can repeat the run with altered connections to the recorder). Thus it is convenient to compare the results of a run just made with earlier ones for the purpose of deciding what further changes in policy or parameters might be worth trying on the next run. A study such as we are planning for this fall will include several hundred runs, surveying the effects of various investment allocation programs, foreign trade policies, and so forth, on underdeveloped economy models with different structural parameters and different initial conditions.

The laboratory setup which acts out the processes we want to study is made by interconnecting various kinds of electronic and electro-mechanical units, each of which receives and produces signals in the form of

electrical voltages which can vary continuously through time. Different kinds of units, embodying different relationships, are appropriately combined into subsystems which behave like parts of the economic model. The subsystems are then interconnected to correspond to the complete model. The simplest type of unit receives several varying signals and produces their continuously varying sum. Another type has an output which follows the input with an exponential lag, according to the relation:  $dy/dt = k(y-x)$ . Its response to a step change in the input signal is shown in Figure 1:

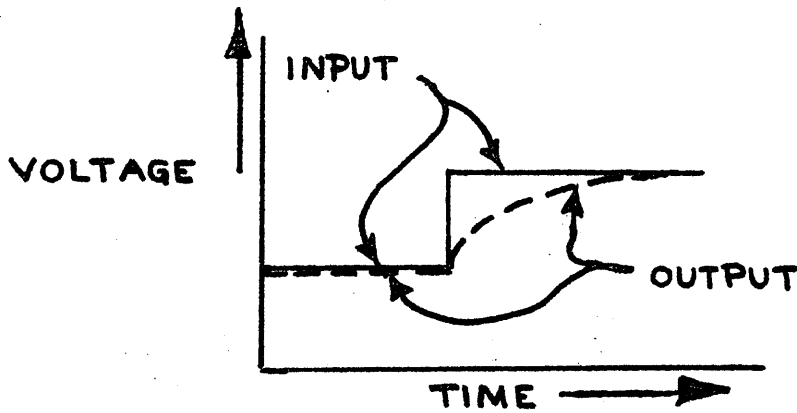

FIGURE 1

Other types of unit integrate variable inputs, multiply or divide two variables, impose ceilings or floors, choose between two signals on the basis of some criterion, or do a number of other operations.

As an example, consider the following set of relations (which are a small part of the economic system model described more fully

later on):

On the basis of available information and certain decision criteria, entrepreneurs, in any particular day or week, make commitments for construction of a number of plants and machines. The number will vary from week to week. It is represented in the model as the time-rate of starting capacity-construction projects. This is a continuous signal, continuously varying. It is symbolized by  $\dot{K}^S$ , and has dimensional units of plants per year, where a plant is defined as a standardized unit of productive capacity. The crude assumption is made that the time required to complete a plant and get it producing is invariant. Therefore, at any given time the rate at which new plants are coming into production is identical to the rate at which construction projects were started  $g$  years previously, where  $g$  is the length of the gestation period:

$$\dot{K}^P(t) = \dot{K}^S(t-g) \quad (1.)$$

The level of construction activity at any time is given by the number of plants under construction (or "in gestation"), which is equal to the number which have been started but not completed:

$$K^S = K^S(t=0) + \int_0^t \dot{K}^S dt - \int_0^t \dot{K}^P dt \quad (2.)$$

The rate of investment expenditure,  $I$ , is determined from  $K^S$ , the number of plants in gestation. Thus it is not subject only to current decisions but is dependent on earlier commitments as well:

$$I = \frac{p^k}{g} K^g$$

Where  $p^k$  is the cost in dollars per plant of capacity-construction, it is a variable, depending on factor and material prices.

The analog of these relations uses a delay unit, whose output voltage is approximately an echo of its input voltage at an earlier time. This simulates Equation 1. Equation 2 is simulated by an integrator, and Equation 3 by an electro-mechanical multiplier. These units are wired together as shown by the arrows in Figure 2 to transmit required information from unit to unit in the form of electrical voltages.

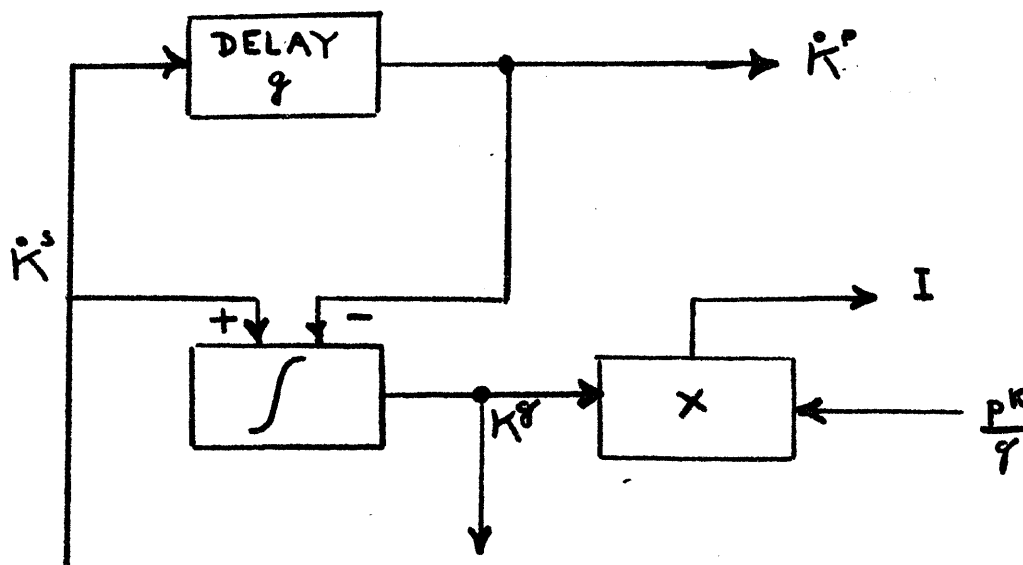

FIGURE 2

No matter how erratically the input signals,  $K^s$  and  $p^k$ , may vary, this combination of units will produce signals according to Equations 1, 2, and 3. Thus it can be wired in as part of a larger system which provides its input information and uses its outputs.

#### THE ECONOMIC SYSTEM MODEL

In the recent pilot operation many simple relations like those in the example above were set up and interconnected to simulate a complex economic model. The principal features of the model are diagrammed in Figure 3 and described below, without further explanation of the analog details. Equations specifying it fully are given in an appendix.

The model represents an underdeveloped economy with production taking place in an agricultural and an industrial sector and with foreign trade. The gestation period relations in the example above pertain to capacity creation in the industrial sector. They are summarized in Figure 3 by one block at the left side labeled "Construction Period." Information coming out of that block includes investment used in the income block above; the number of plants under construction, fed back to the investment decision function as part of the foreseeable capacity change, (the other part is anticipated attrition); the demand for imported capital goods, proportional to  $K^s$ ; and the rate of completion of new plants,  $K^p$  plants per year. This last signal is the input to another sort of delay function, representing the life span of plants. This function is more sophisticated

than that for the gestation period. Its output is not a sharp echo of a previous input time-profile, but is smoothed out over time to simulate a dispersion of life spans of different plants. (See Life-Span function in Figure 3). Information from the life span function determines the capacity of the industrial sector, which is one of the main variable parameters of the short-run supply curve. It also determines the labor-to-output ratio, since labor-saving technological development is correlated with the construction of new plants.

With this information on capacity and productivity, together with wage rates and prices of intermediate goods, a short-run supply function is established, like that shown at the right of the industrial sector. This supply curve, in effect, shifts to the right with physical capital formation, the left hand intercept moving correspondingly downward, and moves up with wages, which rise when business is profitable but do not go down again. The supply function interacts with a demand function to establish a market price. This, with cost information, determines a profit rate, the principal stimulus to investment decisions. Other determinants of the rate of starting plant construction projects are the current cost-of-construction index, expected change in profitability, the number of plants already under construction, the number reaching replacement age, ceilings imposed by government, by inability to import capital goods, or by lack of capacity of the construction industry, and a



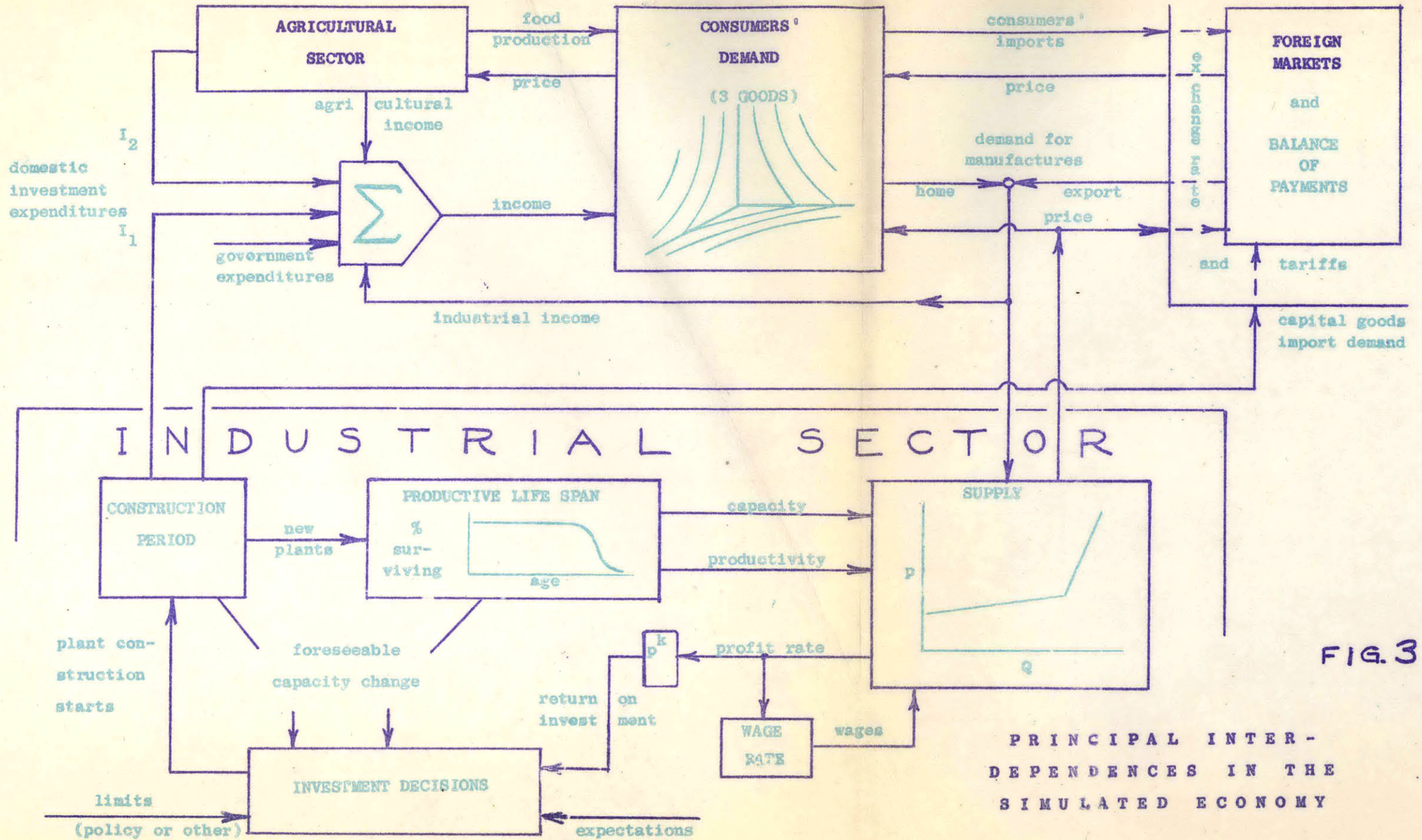

FIG. 3

PRINCIPAL INTERDEPENDENCES IN THE SIMULATED ECONOMY

minimum level which may be government-supported as part of a development program.

Demand for goods from the industrial sector comes both from domestic consumers and from export markets. Demand from abroad is a simple function of the price in foreign currency. For home consumers there is a preference function which determines simultaneously the demand for each of three products in accordance with the three prices and disposable income. Food and imported consumers' goods are consumed as well as industrial products. Imports are supplied at a fixed world price, subject to tariff and exchange rate changes. Food output is inelastic and equal to capacity. Capacity can be changed by investment, but in the example presented in this paper it was fixed throughout the run. Inventory fluctuations are not considered in this model. Thus investment in capacity formation, government expenditures, and production for consumption and export add up to national income. Taxes and business savings out of profits are deducted to get disposable income for the consumers' demand function.

#### RESULTS OF A TYPICAL RUN

This model has been simulated, and the results of one run are presented in Figures 4 and 5 and interpreted below. They show how a particular hypothetical economy would be affected by a currency devaluation in a time of depression.

In the period before zero time the economy was in a state of

slow decline. For these years the volume of exports was constant, the price of manufactured goods was constant, and the home consumption of such goods was slowly declining. These variables are shown in the first three graphs of Figure A. Although it is not shown explicitly there, the physical quantity of manufactured goods demanded for both export and home consumption was less than productive capacity. Because of the low demand, the expected return on new industrial investment was negative, as shown in the fourth graph. The fifth graph shows that some plant construction was nevertheless being undertaken during this period. The rate of starting such construction was less than enough to replace attrition of old plants. The fact that there was any construction at all was due to anticipation of the shrinking of capacity to a level that would match demand and make production profitable.

The next-to-last graph in Figure 4 shows, for the before-zero period, a very low level of gross investment expenditure, corresponding to the level of plant construction. National income, as shown in the last graph on that page, was steadily declining.

Shortly after Year Zero, the currency was devalued relative to that of the outside world. The exchange rate, formerly one peso per dollar became 1.25 pesos per dollar. (In the absence of a balance-of-payments crisis this devaluation would probably have been considered unjustified in the real world. In our laboratory model, however, we are free to carry out our whims just to see what will happen.)

The effect on exports initially was a jump in volume as well as in value in response to the reduced dollar price. Within a year the value of exports in dollars per year had declined to its previous level, as the price rose in line with increasing domestic demand. The step up in peso value of exports was of course reflected in a step up in national income, shown at the bottom of Figure 4, and a step up into the positive range of return on industrial investment (middle of Figure 4). The next graph down shows the response of entrepreneurs in starting construction of new plants. The entrepreneurs in this case were extremely responsive and would have started new plant-building projects at a rate of over 100 per year (dashed line) had they not been limited by the capacity of the construction industry to the rate shown by the solid line. This limit on starts varied in keeping with the objective of limiting the number of plants under construction, i.e., previously started but not yet completed. The number of plants under construction is reflected in the next graph, of expenditures on investment in the industrial sector. (The time scale on this graph is about 1/2 year off in comparison with that just above it; the beginning of the rise in investment should be simultaneous with the jump in the rate of starts.) When enough plant construction projects had been started to meet entrepreneurs' expansion plans, the rate of starting new projects fell rapidly, becoming zero at Year 1 1/2. At this point the declining rate of return would have led to a negative rate of starting projects (dashed line).

This, however, was forbidden by the postulates of the model. and the decline stopped at zero. The projects in gestation at that time were rapidly being completed a year later, Year  $2\frac{1}{2}$ , and new projects again were undertaken, but less rapidly this time, so that investment expenditures were allowed to drop to about half their peak level. From then on, the cycle of starting projects continued repeating in such a way as to keep the fluctuations in investment expenditure fairly small. With exports stimulated by the devaluation, and investment stimulated by the rise in export demand, national income of course rose, leading to a gradual increase in home consumption of home-manufactured goods, which had almost vanished in the previous decline. These effects turned out to be mutually reinforcing. A self-sustaining growth had been started, and continued as long as the run lasted.

The next figure gives the histories of more variables from the same run. National income is repeated in the first graph for reference. The second shows the inflation of food prices and farm income resulting from rising total income while the physical volume of food output was fixed. The peso price of imports, supplied at a fixed world price, is a direct image of the exchange rate (third graph). The consumption of imports, initially reduced by the price boost, soon climbed up to and even above its previous level because of increased income (fourth graph). Exports (fifth graph) moved oppositely to imports in the first few years, giving a fluctuation in the balance of trade (last graph). In the long run, imports,

influenced by rising income, grew faster than exports, which rose only slightly with the slightly increasing productivity and the consequently declining price of industrial goods. Thus the balance of trade drifted into an ever-increasing import surplus.

This example was not presented for the purpose of showing that currency devaluation is a good thing. The parameters of this hypothetical economy happened to be such that a good push in the right direction would start a cumulative process. A "pump-priming" program might have been a better means. Had the parameters been different, corresponding to different technological opportunities, different propensities of entrepreneurs, or any of a variety of other differences, perhaps nothing could have caused growth to begin. It is not even possible to say that this example represents a successful development policy, or that it is better than another in which national income grows less rapidly. In some countries it might be better to accept a slightly lower income growth rate if in so doing an unemployment problem could be solved sooner. Perhaps an increase in food output would be a necessity or more desirable than having all of the growth in industry. Thus the results of a run cannot be evaluated by a single criterion.

The coming simulator study of the problems of starting economic growth will yield a large number of results of particular cases. It is expected that study and comparisons of these results will give increased understanding of the dynamic interactions in the economic

growth process and new insight into the effectiveness of various policies for coping with the problems inherent in the early stages of growth. The same basic technique should prove effective also for many other dynamic economic problems.



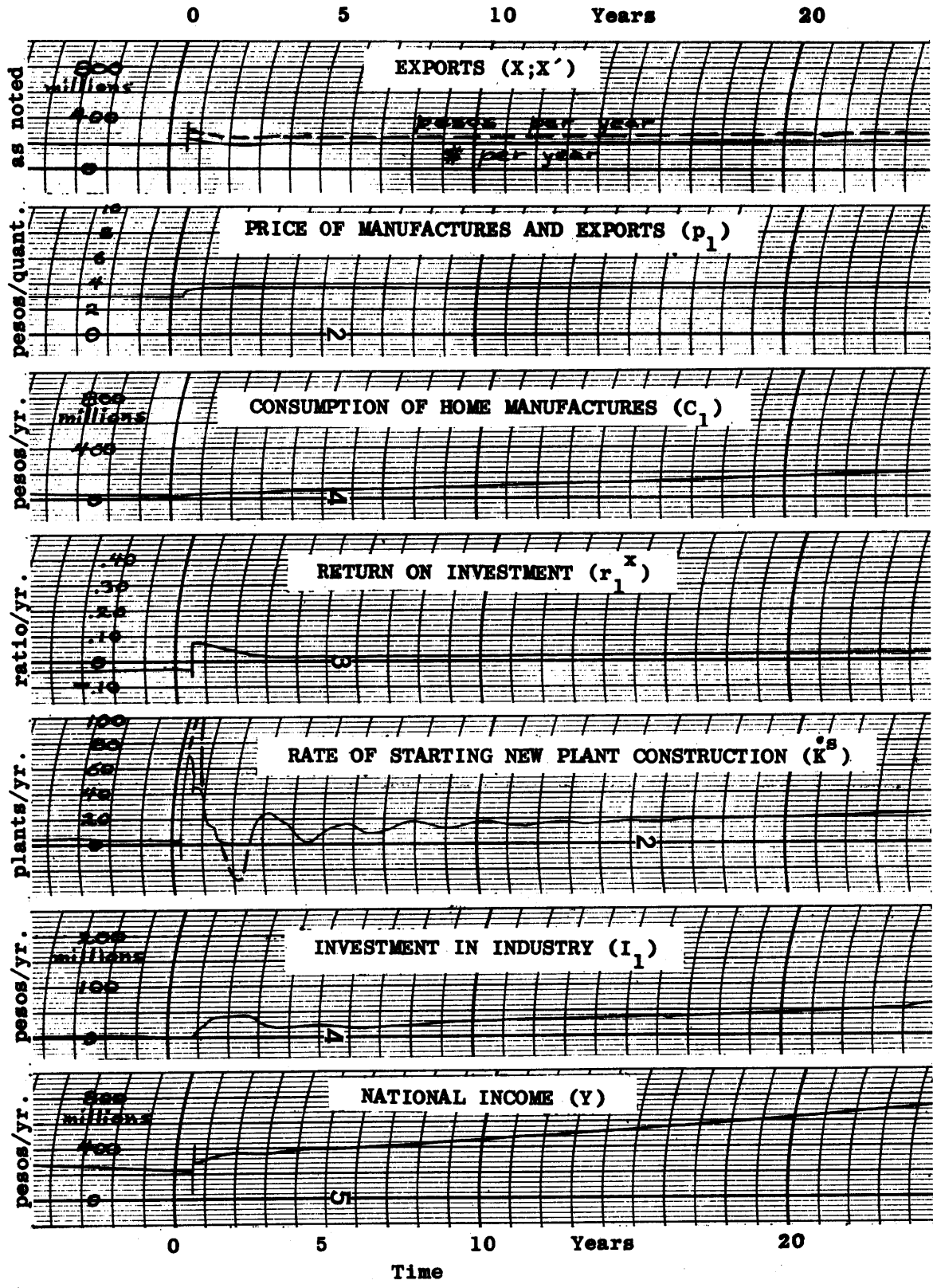

**RESPONSE TO A CURRENCY DEVALUATION**

— from 1 peso/\$ to 1.25 pesos/\$ at about 1/2 year after zero.  
 (Time scales not exactly matched.)

EFFECT ON PROFITS, INVESTMENT, INCOME, ETC.



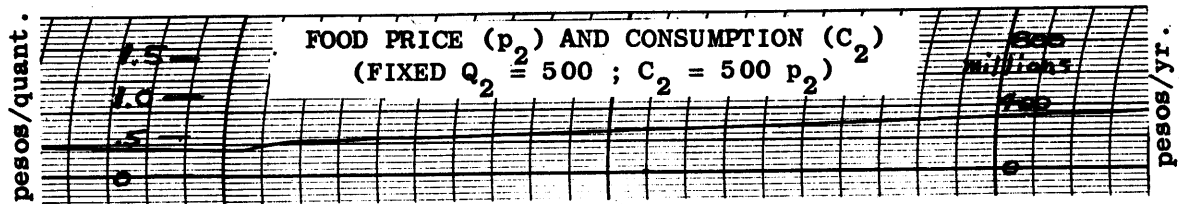
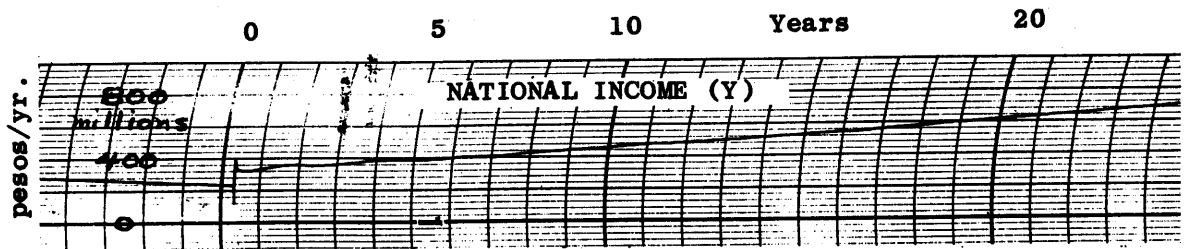

SEE OTHER FIGURE FOR  $p_1$  AND  $C_1$

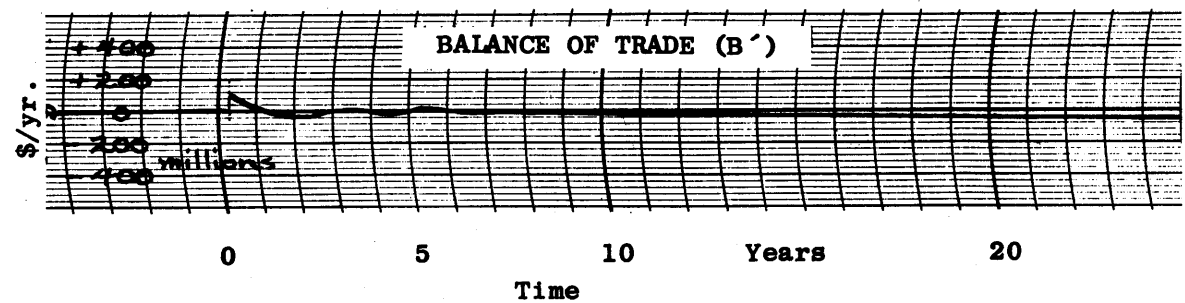
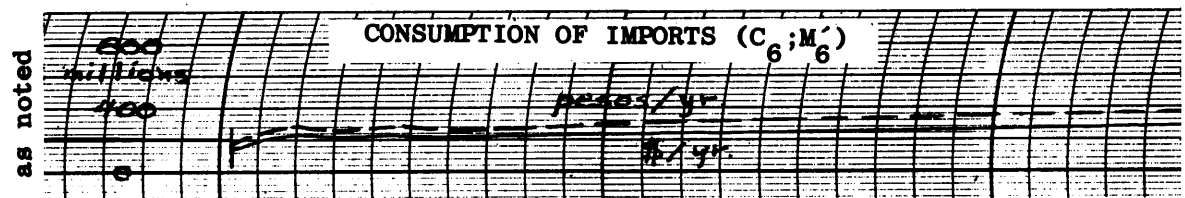
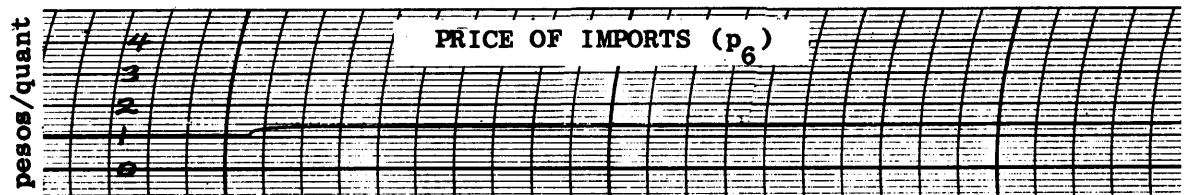

RESPONSE TO A CURRENCY DEVALUATION

— from 1 peso/\$ to 1.25 pesos/\$ at about 1/2 year after zero.  
(Time scales not exactly matched.)

EFFECT ON CONSUMERS' BUDGET AND BALANCE OF TRADE

APPENDIX

Equations of the Economic Model

(Symbols are listed and identified at the end)

Industrial Sector

1.  $\dot{K}^p(t) = \dot{K}^s(t-g)$
2.  $K^g = K^g(t=0) + \int_0^t \dot{K}^s dt - \int_0^t \dot{K}^p dt$
3.  $I = \frac{p}{g} K^g$
4.  $\frac{dK^r}{dt} = \frac{1}{a} \left[ \begin{array}{c} \dot{K}^r(t) \\ K^p(t-(d-g-a)) \end{array} \right]$   
(delay followed by exponential lag)
5.  $\dot{K}^d(t) = \dot{K}^r(t-g)$
6.  $K^e = K^e(t=0) + \int_0^t \dot{K}^r dt - \int_0^t \dot{K}^d dt$
7.  $\bar{K} = \bar{K}(t=0) + \int_0^t \dot{K}^p dt - \int_0^t \dot{K}^d dt$
8.  $K^p = K^p(t=0) + \int_0^t \dot{K}^p dt$
9.  $\dot{K}^* = \dot{K}^r + \lambda[\Gamma r^x + K^e - \alpha K^g]$
10.  $\dot{K}^s = \dot{K}^*$ , subject to limits, thus  $= 0 \leq \dot{K}^s \leq \bar{K}$   
( $\bar{K} = 0$  in example)
11.  $\bar{K} = \psi(\phi \bar{K} - K^g)$

$$12. \quad r^x = r - \Delta h \quad (\Delta h = 0 \text{ in example})$$

$$13. \quad r = \frac{\pi^{\max.}}{p^k}$$

$$14. \quad \pi^{\max.} = p - p_{\min}^f - hp^k$$

$$15. \quad p_1^k = k \frac{p_{\min}^f}{p_1} + k_{j,1} w_1 + q_{7k} p_7$$

$$16. \quad p^f = w(L/Q)$$

$$17. \quad p_{\min}^f = w(L/Q)_{\min}$$

$$18. \quad (L/Q)_{\min} = (L/Q)^0 - \xi k^p$$

$$19. \quad (L/Q) = (L/Q)_{\min} + \xi Q$$

$$20. \quad p_1 = w_1(L/Q)_1 + q_{61} p_6 + \zeta(Q - \bar{Q})^+$$

Last term omitted if negative. ( $q_{61} = 0$  in example)

$$21. \quad Q_1 = C_1/p_1$$

$$22. \quad \pi_{av} = p - p_{\min}^f - 1/2 \left( \frac{\partial p^f}{\partial Q} \right) Q - hp^k$$

$$23. \quad \frac{dw}{dt} = \rho \pi_{av}$$

$$24. \quad \Pi = \pi Q$$

### Agricultural Sector

In the example here, capacity was fixed and output always equal to capacity:

$$25. \quad Q_2 = \bar{Q}_2$$

$$26. \quad p_2 = C_2/Q_2$$

Income and Demand

$$27. Y = I_1 + I_2 + C_1 + C_2 + X + G$$

$$28. Y^D = Y(1 - t) - \sigma_{\pi} \Pi$$

$$29. C_2 = p_2 Q_2^{\circ} + b_2 [Y^D - p_2 Q_2^{\circ}]$$

$$30. C_c = C_1 + C_6 = b_c [Y^D - p_2 Q_2^{\circ}]$$

$$31. C_1 = p_1 Q_1^{\circ} + b_1 [C_c - p_1 Q_1^{\circ} - p_6 Q_6^{\circ}]$$

$$32. C_6 = p_6 Q_6^{\circ} + b_6 [C_c - p_1 Q_1^{\circ} - p_6 Q_6^{\circ}]$$

In the relations above, the b's and Q<sup>o</sup>'s are constants. Q<sub>1</sub><sup>o</sup> and Q<sub>6</sub><sup>o</sup> had negative values, which makes for higher substitutability. Under some conditions either Equation 31 or Equation 32 would give a negative result. During such periods both of them were bypassed and replaced by:

$$33. \left. \begin{array}{l} C_1 = C_c \\ C_6 = 0 \end{array} \right\} \text{if Equation 32 gives negative result.}$$

or

$$34. \left. \begin{array}{l} C_1 = 0 \\ C_6 = C_c \end{array} \right\} \text{if Equation 31 gives negative result.}$$

$$35. p_6 = x p_6' \quad (p_6' \text{ const. } t)$$

$$36. M_6' = \frac{1}{x} z_6$$

$$37. X' = X^{\circ} - \sqrt{p_1'}$$

$$38. p_1' = \frac{1}{x} p_1$$

$$39. B' = X^{\circ} - M'$$

SYMBOLS

$\dot{K}^*$	Entrepreneurs' desired rate of starting industrial capacity - creation projects,	(plants per year)
$\dot{K}^S$	Actual rate of starting such projects.	" " "
$\dot{K}^D$	Rate of new plants coming into production.	" " "
$\dot{K}^R$	Rate of old plants reaching "replacement age" (death anticipated by one gestation period).	" " "
$\dot{K}^d$	Rate of death of plants	" " "
$\bar{K}$ , $\underline{K}$ Upper and lower limits, respectively, on $\dot{K}^S$ .		
$K^G$	Productive capacity under construction	(plants)
$K$	Capacity in existence; numerically equal to Q.	"
$K^e$	Capacity over "replacement age" but still usable.	"
$K^P$	Total capacity constructed without deducting attrition. (Equivalent to serial number of newest plant).	"
$g$	gestation period	(years)
$d$	duration of life-span (average)	"
$a$	dispersion of life-spans	"

I	Investment expenditure rate	(pesos per year)
Y	National income	" " "
$Y^D$	Disposable income	" " "
$\Pi$	Profits	" " "
C	Consumption expenditures	" " "
G		
G	Government "	" " "
M	Import "	" " "
X	Export receipts	" " "
$M'$	Import expenditures	(\$ per year)
$X'$	Export receipts	" " "
$B'$	Balance of trade	" " "
Q	Physical quantity rate of production	(quants per year)
$\bar{Q}$	Physical capacity of sector; numerically equal to $\bar{K}$	" " "
L	Labor input	(man-hours)
p	price of goods	(pesos per quant)
$p^k$	Cost of capacity-creation	(pesos per plant)

w	Wage rate	(pesos per man-hour)
$\pi$	Profit rate	(pesos per quant)
$\theta\pi$	Rate of taxation plus saving out of profits	(ratio)
t	Other tax rate or tariff rate	"
r	Current rate of return based on current replacement cost	( $\frac{\text{pesos/yr.}}{\text{pesos}}$ )
$r^x$	Expected future rate of return based on current cost.	"
x	Exchange rate	(pesos per dollar)

All other lower case and Greek letters are parameters identifiable from the context in which they occur.

- Subscripts:
1. Industrial sector
  2. Agricultural sector
  - 3, 4, 5, (omitted)
  6. Consumers' imports
  7. Capital-goods imports