

MIT Open Access Articles

A scalable 2.9mW 1Mb/s eTextiles body area network transceiver with remotely powered sensors and bi-directional data communication

The MIT Faculty has made this article openly available. **Please share** how this access benefits you. Your story matters.

Citation: Desai, N. V., J. Yoo, and A. P. Chandrakasan. "A Scalable 2.9mW 1Mb/s eTextiles Body Area Network Transceiver with Remotely Powered Sensors and Bi-Directional Data Communication." 2013 IEEE International Solid-State Circuits Conference Digest of Technical Papers (February 2013).

As Published: <http://dx.doi.org/10.1109/ISSCC.2013.6487702>

Publisher: Institute of Electrical and Electronics Engineers (IEEE)

Persistent URL: <http://hdl.handle.net/1721.1/92839>

Version: Author's final manuscript: final author's manuscript post peer review, without publisher's formatting or copy editing

Terms of use: Creative Commons Attribution-Noncommercial-Share Alike



11.8 A Scalable 2.9mW 1Mb/s eTextiles Body Area Network Transceiver with Remotely Powered Sensors and Bi-Directional Data Communication

Nachiket V Desai¹, Jerald Yoo², Anantha P Chandrakasan¹

¹Massachusetts Institute of Technology, Cambridge, MA, ²Masdar Institute of Science and Technology, Abu Dhabi, United Arab Emirates

Advances in sensor design have made ambulatory health monitoring possible and have created the need for low-power communication systems to replace bulkier traditional links. Micropower sensors should also be powered by a non-local energy source for system miniaturization and long life. Recently proposed communication systems using wireless body area networks [1,2] and body-coupled communication [3] suffer from high path loss around the human body for efficient remote power delivery. In contrast, eTextiles are becoming an increasingly popular technology for efficiently powering and communicating with such sensors [4-6] due to wide coverage around the human body combined with low path loss and comfort of use.

Fig. 11.8.1 shows the hybrid wireless/wireline network implemented in this work. Near-field (inductive) power and bi-directional data links between an eTextiles shirt and sensor nodes (SNs) have been combined with a wireline interface between the shirt and a base station, offering greater comfort with the advantages of differential signaling [4]. Groups of parallel inductors in close proximity, called *sub-networks*, can be placed anywhere on the shirt offering greater coverage and flexibility than an (X,Y)-addressable grid [5] or a bus [6] architecture without a corresponding increase in complexity. Sub-networks are enabled independently to allow the network to serve any combination of SNs. Redundant paths to each sub-network reduce the risk of failure from faults (opens) induced during everyday use. The SNs use a similar fabric patch inductor that forms the other half of the inductive link. A custom-designed MAC controls multiple-access for SNs in the network.

The architecture of the base station implemented with 2 sub-networks is shown in Fig. 11.8.2. Each sub-network on the shirt has its dedicated on-chip analog interface, which handles power delivery, data modulation and demodulation for the inductors in that sub-network. Power is transmitted at 27.12MHz by a self-tuned oscillator-PA architecture that eliminates the need for a separate large low-frequency oscillator tank. Downlink data from the base station to the SNs is broadcast at 80kb/s to all SNs in a sub-network using pulse-width modulation (PWM) on the envelope of the PA output. Uplink data to the base station is transmitted by the SNs via OOK impedance modulation at 1Mb/s on the same carrier. Demodulated outputs from each sub-network are combined and sent to the on-chip digital baseband circuitry. A 4-step linear power regulator controls the amount of power transmitted to each sub-network. The MAC Decision Engine (MAC-DE) controls network access and ensures data integrity through a CRC-based Automatic Repeat Request (ARQ) scheme.

The circuits used for resonant power transfer are shown in Fig. 11.8.3. The resonant LC tank in the self-tuned oscillator-PA feedback loop is made up of the fabric inductors and on-chip capacitors tuned once before use. The capacitors employ 2-level adjustment to maintain the oscillation frequency: coarse adjustment based on the number of inductors in the sub-network and fine adjustment to compensate for up to 20% inductor tolerance. The tank is made symmetric about ground in order to double the differential swing across the fabric inductors, which improves the efficiency of the rectifier at the sensor nodes. The rectifier at the SN is fed by the fabric patch on the inductor that resonates with an on-chip capacitor, and is made up of four AC-coupled auto-commutative rectifiers (ACRs) connected in series on the DC path [7]. Each ACR comprises of cross-coupled PMOS and NMOS transistors that turn on strongly during the peaks of the AC input and deliver net positive current to the DC outputs. The power link has been measured to supply up to 20 μ A at 1.7V, at a peak system efficiency of 1.2%, which is 6x higher than the system proposed in [5].

The architecture of the SN with general-purpose power recovery and fully digital communication modules that interface with application-specific readout circuitry is shown in Fig. 11.8.4. An interpreter decodes instructions sent by the base station regarding network access and uplink packet structure, and activates the necessary digital blocks for transmission. After waking up, a SN only accesses the network when instructed by the base station, which eliminates the need for wake-up time synchronization [2]. Biological data is buffered at each SN for transmission in bursts. Uplink packets are divided into multiple segments of

dynamically variable sizes based on the BER, each transmitted with its own 16b CRC for error detection. The rectifier recovers transmitted energy at all times except when the sensor is transmitting, which could be up to 40ms long and during which the sensor operates from energy buffered in an off-chip capacitor. Binary PWM is used in the downlink path to avoid clock recovery circuits with large quiescent power at the sensor nodes (Fig. 11.8.5). Unlike its analog counterpart, the digital demodulator does not rely on a current source dumping charge on a capacitor to generate a ramp, and hence consumes no static power. The low-data rate PWM signal is oversampled by 12x using the on-chip 1MHz system clock. Two counters count the number of cycles the PWM signal is at 1 or 0 respectively, and their outputs are compared at the end of the bit and reset. The use of differential demodulation eliminates the need for an accurate reference.

In order to efficiently allocate network resources to a large heterogeneous group of SNs, a hybrid asymmetric MAC protocol with automatic network configuration capability has been integrated. SNs that continuously stream data, such as ECG or EEG sensors, are allocated fixed TDMA timeslots, whereas SNs that measure small amounts of data infrequently, such as temperature or blood pressure monitors, access the network through an acknowledgement- (ACK) based Contention Access (CA) scheme. During configuration, SNs have 1s after receiving the beacon to transmit their response and be assigned a unique 7b network ID. The network subsequently rotates every 4s between cycling through all SNs with fixed TDMA time slots and designating the rest as CA period, where SNs with data to transmit access the network after a random delay (Fig. 11.8.6).

The base station and SN have been fabricated in a 0.18 μ m CMOS process and occupy core areas of 2.95mm² and 1.46mm² respectively. The base station has been tested with 3 out of a maximum of 128 possible SNs, and consumes 2.9mW while powering and communicating with one SN over a 2cm link, of which 158 μ W is consumed by the demodulator, CDR and digital baseband circuits. The sensor node interface circuits consume an average of 14 μ W, leaving up to 20 μ W, which is sufficient to power state-of-the-art biomedical acquisition circuits. Waveforms during network configuration are shown in Fig. 11.8.6, along with a performance summary. Fig. 11.8.7 shows die photos for the base station and SN.

Acknowledgements:

This work was funded by the cooperative agreement between the Masdar Institute of Science and Technology, Abu Dhabi, UAE and the Massachusetts Institute of Technology, Cambridge, MA, USA, Reference No. 196F/002/707/1021/70/9374. The authors would like to thank members of the Semiconductor System Lab at KAIST for assistance with eTextiles fabrication.

References:

- [1] M. Verhelst et al., "A Reconfigurable, 0.13 μ m CMOS 110pJ/pulse, Fully Integrated IR-UWB Receiver for Communication and Sub-cm Ranging", *ISSCC Dig. Tech. Papers*, pp. 250-251, Feb. 2009.
- [2] A. Wong et al., "A 1V, Micropower System-on-Chip for Vital-Sign Monitoring in Wireless Body Sensor Networks", *ISSCC Dig. Tech. Papers*, pp. 138-139, Feb. 2008.
- [3] T. Roh et al., "A 259.6 μ W Nonlinear HRV-EEG Chaos Processor with Body Channel Communication Interface for Mental Health Monitoring", *ISSCC Dig. Tech. Papers*, pp. 294-295, Feb. 2012.
- [4] P. Mercier et al., "A 110 μ W 10Mb/s eTextiles Transceiver for Body Area Networks with Remote Battery Power", *ISSCC Dig. Tech. Papers*, pp. 496-497, Feb. 2010.
- [5] J. Yoo et al., "A 5.2mW Self-Configured Wearable Body Sensor Network Controller and a 12 μ W 54.9% Efficiency Wirelessly Powered Sensor for Continuous Health Monitoring System", *ISSCC Dig. Tech. Papers*, pp. 290-291, Feb. 2009.
- [6] S. Lee et al., "A 75 μ W Real-Time Scalable Network Controller and a 25 μ W ExG Sensor IC for Compact Sleep-Monitoring Applications", *ISSCC Dig. Tech. Papers*, pp. 36-37, Feb. 2011.
- [7] S. Mandal et al., "Low-Power CMOS Rectifier Design for RFID Applications", *IEEE Trans. Circuits Syst. I*, vol. 54, no. 6, pp. 1177-1188, Jun. 2007.

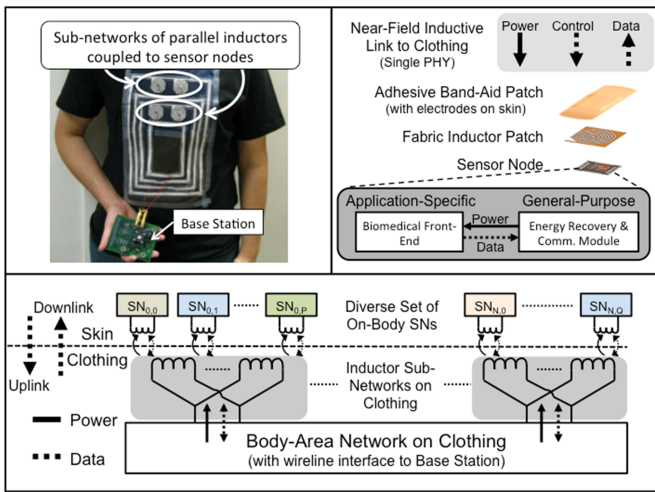

Figure 11.8.1: An eTextiles body area network architecture controlled by a base station with power and bi-directional data transfer. The shirt is worn inside out to show inductors on clothing.

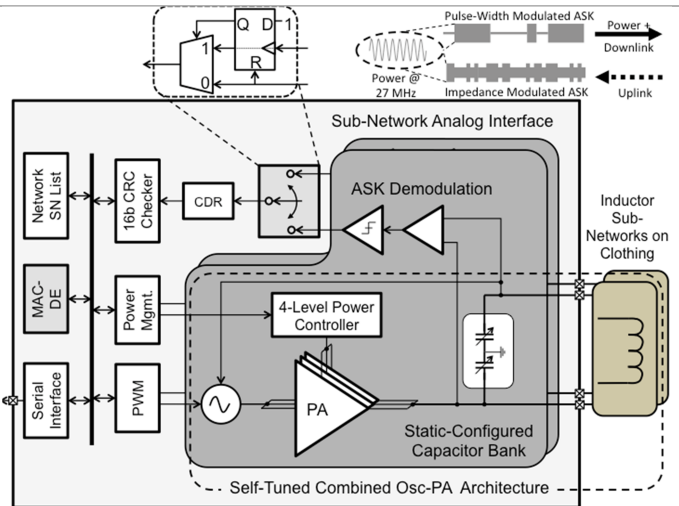

Figure 11.8.2: Block diagram of the base station with typical waveforms for uplink and downlink data transmission

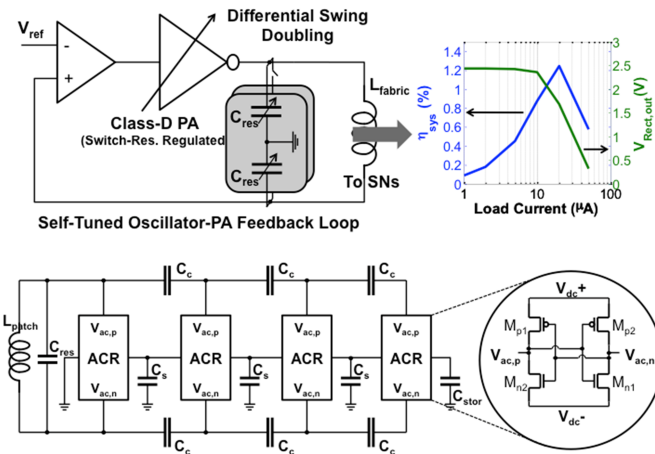

Figure 11.8.3: Circuits used for power transmission at the base station and rectification at the sensor node and power transfer measurement results

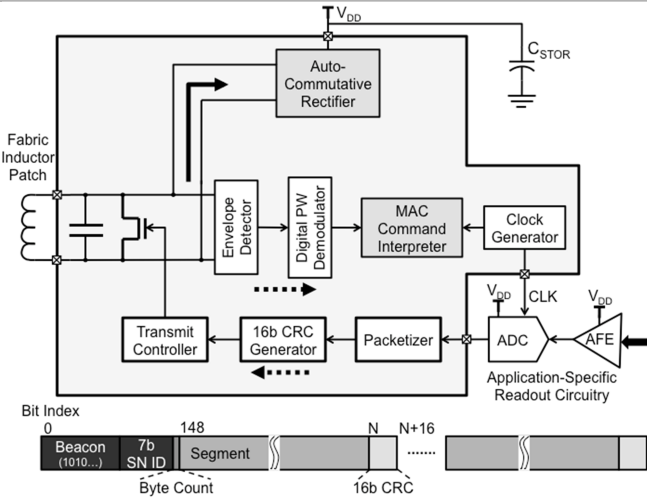

Figure 11.8.4: Block Diagram of sensor node with off-chip application-specific biomedical front-end and uplink packet structure

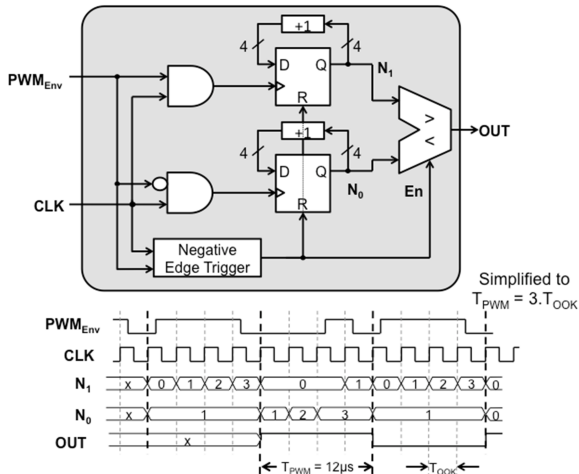
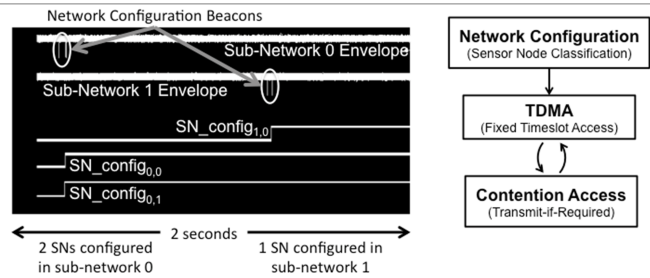

Figure 11.8.5: Differential Digital Pulse Width Demodulator with sample waveforms



Design Summary		[2]	[3]	[5]	[6]	This Work
Technology	: 0.18μm					
Supply Voltage	: 2V (BS PA) 1.4V (BS rest)					
Core Area	: 1.46mm ² (SN) 2.95mm ² (BS)					
Frequency	: 1MHz					
Multi-Access	: TDMA + CA					
Max. SN Count	: 128					
Type	Narrow-band RF	BCC	Wireless eTextiles	Wired eTextiles	Wireless eTextiles	
Coverage	Wide	Local	Local	Local	Wide	
Link Power (1 BS + 1 SN)	4.7mW*	4.8mW*	5.2mW	100μW	2.9mW	
Data Rate	50kb/s	1.25Mb/s	120kb/s (UL only)	20Mb/s	1Mb/s (UL) 80kb/s (DL)	

*Communication only, no remote SN power delivery

Figure 11.8.6: Waveforms for network configuration with 3 SNs arranged in 2 sub-networks, mode transition diagram for the hybrid MAC protocol and chip performance summary