

# Subjects, Events and Licensing

by

Heidi Britton Harley

Bachelor of Arts,  
Linguistics and English  
Memorial University of Newfoundland  
(1991)

Submitted to the Department of Linguistics and Philosophy  
in partial fulfillment of the requirements for the  
degree of

Doctor of Philosophy

at the

MASSACHUSETTS INSTITUTE OF TECHNOLOGY  
August 1995

© 1995 Heidi Harley  
All rights reserved

The author hereby grants to MIT permission to reproduce and to distribute publicly  
paper and electronic copies of this thesis document in whole or in part.

Signature of Author .....  
Department of Linguistics and Philosophy  
June 19, 1995

Certified by .....  
Alec P. Marantz  
Thesis Supervisor

Accepted by .....  
Wayne O'Neil  
Head, Department of Linguistics and Philosophy

MASSACHUSETTS INSTITUTE  
OF TECHNOLOGY

SEP 28 1995 ARCHIVES

LIBRARIES



*Subjects, Events and Licensing*  
by  
Heidi Britton Harley

Submitted to the Department of Linguistics and Philosophy in partial fulfillment of the requirements for the Degree of Doctor of Philosophy in Linguistics

While the notion of “subject” as a primitive of grammar is in some way encoded in most modern syntactic theories, the cluster of syntactic properties attributed to subjects is not a homogenous one. This thesis aims to precisely characterize certain of these properties, partially through an investigation of constructions where they fail to converge.

Two of these properties are of particular interest. First, the structural properties associated with “external arguments” are examined, that is, the question of where thematic subjects (as opposed to clausal subjects) are base-generated. Drawing on evidence from Japanese lexical causatives, a “split-VP” structure is argued for, in which external arguments (Agents, Causers) are generated in the specifier of a projection which marks the introduction of an event argument (hence termed EventP). Below EventP are case-checking positions for underlying objects and indirect objects (internal arguments) as well as the projection in which internal arguments are base-generated (“BaseP”). “Verbs” on this approach consist of a “Base” head in combination with an “Event” head, and the decomposition of verbal meaning into “primitives” such as CAUSE, HAVE or BE is assumed. In support, a correlation is drawn between the existence of the predicate “have” in a language and the possibility of a double object/double complement alternation, adducing evidence from Irish, Tagalog and Diné, as well as Japanese, Georgian and English.

Secondly, the question of morphological nominative case is considered. Nominative marking on an NP is typically taken to be an indicator of subjecthood, nonetheless, there are constructions in which a nominative-marked argument appears to be in object position. Such nominative objects in Icelandic are examined in detail, and a mechanism for assigning morphological case is proposed which modifies standard assumptions about the strict connection of morphological case with structural position. Given such modification, the question of NP-licensing is re-examined, with an eye to dispensing with abstract case entirely; the apparent effects of abstract case assignment (and, incidentally, Buzio’s Generalization) are seen to be the result of the interaction of the mechanism governing morphological case assignment with the Extended Projection Principle.

Thesis supervisor: Dr. Alec P. Marantz





## Acknowledgments

I thought about writing my acknowledgments in rhyming verse, but my powers of lyric expression didn't seem equal to the task. I'll just have to try to express my heartfelt gratitude to the people who have helped me through these last four years in plain prose, and hope that is enough to get the message across. I'm probably going to go on for a while, as it isn't often that one gets the opportunity to formally acknowledge the important people, so brace yourselves. Of course, the usual disclaimer applies, with respect to the dissertation.

I'll start in the time-honored fashion with my advisor. Alec Marantz has been a bright spot throughout my graduate career at MIT, but I didn't even begin to appreciate the true extent of his abilities as a scholar and a person until he shouldered the difficult task of shepherding me through the process of writing a thesis. It goes without saying that most of the good of the thesis is the direct result of suggestions and insights of Alec's: his contributions are to be found throughout. Much of the thesis relies upon a view of lexical organization that originates with him, and the rest of it centers on a notion of dependency relations in syntax that also originates with him. A large part of my linguistic education has been accomplished while meeting with Alec; he is responsible for any steps I have made away from my tendency to oversimplify issues. He always kept pushing me to ask the harder question, make the stronger prediction, pursue a correlation or hypothesis and pin it down properly; he read some of the roughest prose I've ever churned out without undue prejudice. I'm greatly indebted to him for being the rigorous, vital and horrendously keen intellect that he is, as well as a generous and thoughtful friend who was always ready to help with anything from moving day to conference organizing. I couldn't have asked for anything more in the way of a guide through this last year. And he has a cute cat, too. Hi Gnocchi!

The other members of my committee, Ken Hale, Shigeru Miyagawa and David Pesetsky, are to be equally thanked and lauded. Ken, one of the busiest people I have ever met, has always had time, energy and interest to spare for me and my work, for which I cannot thank him enough. His insight into and work on the underlying structure of linguistic representations has been the core around which a large part of the thesis is built, and it has been a privilege to work with him. I count myself very fortunate to have had the benefit of his vast experience of language and his ability to pick out and dissect the genuinely interesting part of a given piece of linguistic analysis. (I'd also like to thank him for introducing me to the Band in Boston and the Lowell fiddle contest; we'll have to go for second prize next year, eh Ken?)

Shigeru is responsible for introducing me to the vast and intricate world of the Japanese causative, and helping me negotiate my way through it. The discussion of "word"-level processes and the view of l-syntax presented here was directly inspired by his work on the lexical causative, and the discussion of the case alternations in analytic causatives owes much to his comments and suggestions and knowledge of the literature. I always looked forward to my meetings with Shigeru; discussions with him were inevitably animated and fascinating, and I always came out of them feeling inspired and eager to get to work.

When he heard my avowed intention of exploring the properties of dative-nominative experiencer subject constructions for my syntax generals paper, David suggested to me that the interaction of the Extended Projection Principle and Case Theory would prove to hold the key to the mysteries of said constructions, and that insight has been the focus of much of the better work I accomplished in the intervening two years. This is typical of discussion with David: ideas, insights and analyses flow out of him in a never-ending stream, any one of which contains enough intriguing and thought-provoking material to keep a student busy for months. His suggestions and counterproposals led to much fruitful work and kept me honest. Also thanks to David for many truly great lectures.

I am very grateful to all my committee, and indeed to all the faculty who've had to educate me at MIT for their tolerance of my lousy work habits, and of course for their stimulating and exceptional classes. Irene Heim valiantly attempted to arouse in me a true

understanding of semantics, and was a valued member of my generals committee. Jim Harris was also on my generals committee, and brought the interesting world of Spanish clitics to my attention; when I get back to the morphological end of things I look forward to attacking the paradigm from Mexican Spanish that he pointed out to me. Also thanks to Jim for his cheery execution of the registration officer's duties. Morris Halle and Michael Kenstowicz gave great and memorable phonology lectures, and Morris was largely responsible for directing and encouraging the work I did for my morphology generals. Nothing can match the excitement and feeling of privilege one gets from being Noam Chomsky's student; getting to think about and discuss Minimalism as it came hot off the presses in class was a highlight of my time here. Wayne O'Neil was a constant reassuring presence, and presided over a very entertaining and informative Survey class. Jim Higginbotham, Ken Wexler and Utpal Lahiri gave me a feel for the formal underpinnings of the field, high on a big TM, the memory of which is reassuring to someone who occasionally worries about slipping away from the realm of truly provable hypotheses. Finally, Suzanne Flynn introduced me to the world of academia from the teacher's perspective, for which I am ever grateful—it turns out I enjoy it very much.

The excellence of the MIT program rests largely on the incredible environment of intense and impassioned discussion which the teachers and most especially the students create. A huge chunk of my education has been the result of such discussions; my fellow students are at least as responsible for my current state of linguistic understanding as my professors. My classmates, to begin with, couldn't be bettered.

Masha Babyonyshev helped with the Russian in Chapter 3 and did sterling last-minute proofreading; she has been a terrific and ticklish classmate. Andrew Carnie's insights and suggestions are to be found in enormous abundance throughout this thesis. Indeed, his constant companionship, support and collaboration have been indispensable in getting this thing written at all. He was always there to help me out with anything, from discussing the latest worrying implication, often at 2 am, to reassuring me in moments of crisis, to picking up my car from our buddies Phil and Pat. He is a scholar in the truest sense of the word and has inspired in me a sense of responsibility to language that I hope lasts the rest of my life. He has made this year as fun and rewarding as it could possibly be. I can't thank him for everything here, but I just have to add thanks for teaching me to dance, Drewling. Snork. \*click\*. Do not. Thanks to erstwhile classmate Shawn Kern for lots of good pool and pinball. Masa Koizumi has been extremely helpful with comments and Japanese judgements; a large chunk of Chapter 3 relies on his work as well. Renate Musan has been a semantic resource for four years; in addition, thanks to her I know the meaning of *Strumpf*. Orin Percus' cheerful and intelligent presence has made four tough years less tough and more thespian; he also is to be thanked for gentle semantic guidance, dinners in the North End, and evenings of charades. Colin Phillips couldn't have been bettered as a conference co-organizer, and should be thanked for being his constantly helpful, informative, and good-natured friendly self; also, it is largely thanks to his tireless MITWPL efforts that the standard of living around here has skyrocketed. Finally, Hubert Truckenbrodt, in addition to being a great and fun housemate for two years, helped me with dative experiencers and was very polite to me about T-shirts. They all made for a stimulating and intense four years, and I'll miss them very much.

Although Ling-91 are an exceptional bunch, students from other years were at least as important in seminars, support, ling-lunches, helpfulness, and general ambience-forming. With respect especially to this thesis, I owe a big debt of thanks to Norvin Richards, who gave me exhaustive comments and endless encouragement. Jonathan Bobaljik also is to be thanked for his extensive thoughtful and constructive input, as well as for being a terrific housemate and friend, always generous, relaxed, and supportive, despite living at a pace that I'm sure would kili most of us. MarthaJo McGinnis has been a boon for the last two years as a housemate, friend, and fellow worrier-about-weird-cases; late-night discussions with her about Georgian and Icelandic and other important life-issues have lightened my life, even if she does cut her bananas funny. Uli Sauerland was another

great housemate and climbing and tennis partner. Thanks to Pilar Barbosa for sharing this thesis-writing year with me, and commiserating regularly over the difficulty of it all. Thanks to Rob Pensalfini for friendliness and tokens. Carson Schütze deserves thanks for case comments and other discussions. Chris Collins taught a great recitation in baby syntax, as well as providing constructive discussion during my morphology generals. Danny Fox, Judy Baek, Ayumi Ueyama and Hiroyuki Ura have all been a help with data and discussion at various points. Akira Watanabe was a great TA for the Philosophy of Language, and has helped me at other points with discussion and comments. Rolf Noyer helped me greatly with my morphology generals paper. Hamida Demirdache, Kumiko Murasugi and Tom Green were reassuring and fun housemates during my first summer here. Other MIT students I have to thank include Tony Bures, Kathleen Williams (another worthy housemate), Hooi-Ling Soh, Vaijyanthi Sarma, David Braun, Taylor Roberts, Dylan Tsai, Seth Minkoff, Michelle Sigler, Susi Wurmbrand, Diana Cresti and Ingvar Löfstedt. Maya Honda is to be remembered for chocolate and compassion, and Andrea Zukowski for friendship and many delicious and fun evenings. Hi Leo! The administrative staff have smoothed life around here out as much as possible, their work on our behalf is really appreciated. Thanks to Bev Stohl for racquetball, cheer, chocolate and not spitting on me too much, Rachel Pearl for endless money requests and song, Jen Purdy for thesis trivia and softball, Jamie Young for making NC available, and Wendy Webber for her, uh, sewing machine. I know there are many I haven't remembered to include, please accept my apologies for not naming you specifically: thanks to everybody in the MIT linguistics community.

There are many linguists outside MIT who have been crucial in getting me to this point as well, of course. I'll start with my Memorial University of Newfoundland faculty, who introduced me with great ability and enthusiasm to this wonderful field. Jim Black taught me my first linguistics class, and had me hooked immediately. David Nurse, Aleks Steinberg, Harold Paddock, Vi: Bubenik and Sandra Clarke all taught entertaining, challenging courses that made my undergraduate career a memorable experience. The main reason I am a linguist at this moment is the series of syntax classes I took from Leslie Saxon, which introduced me to rigorous syntactic argumentation and the excitement of formal linguistic theory in the best possible way. She was also a terrific help with the Athapaskan herein; I only wish I had consulted her sooner. Many many thanks, Leslie.

Other linguists who have helped me along the way with comments and encouragement include Höskuldur Thráinsson (always patient with last-minute demands for data), Dianne Jonas, Eiríkur Rögnvaldsson, Joan Maling, Alice Davison, Stan Dubinsky, Keren Rice, Liz Cowper, Betsy Ritter, Caroline Heycock, Andrea Moro, Sabine Iatridou, Lisa Travis, Liliane Progovac and audiences at the various conferences I've attended over the last four years. Elizabeth Pyatt helped especially with the Old Irish in Chapter 2. I would like to thank my co-author and friend Rosanne Pelletier for gently introducing me to the world of conference presentations and for much help, support and fun in the intervening years, as well as invaluable last-minute proofreading. Thanks-*aNDi*!

Surprisingly enough, I've found time for a pretty wide variety of extra-curricular activities, which has made my life and play-time contentful and rewarding, as well. I'd like to thank the potters (especially Chin and Geoff), climbers (especially Lori and Deb, great friends, both), softball players (especially Amy), musicians (especially the Band in Boston) and dancers (all of you, love you all). These people have been as important to my years here as the more extensively-discussed linguists above; I will miss them tremendously, and hope to stay in touch at least with the skills they taught or learned with me.

From my pre-MIT life, there are friends who will always be with me and who I dearly love; they are part of my family and thank them for being there: Brenda, Cass, Robin, Dawn, Toby and Maren.

And finally, there is my family: my parents, Carolyn and Peter and my brother, Jonah, for whom no offering of thanks could ever be adequate, just all my love.



## Table of Contents

Title Page	1
Abstract	3
Acknowledgements	5
<b>Chapter 1: “Subject”</b>	<b>13</b>
1.1 A syntactic “subject” position: agents vs. “subjects”	15
1.2 “Subject” property mismatches	18
1.3 Conclusion	23
<b>PART I: PROJECTION</b>	<b>25</b>
<b>Chapter 2: Where don’t they come from?</b>	<b>27</b>
2.1. Against Subjects in Spec-IP	28
2.1.1 Conjunction of actives and passives	28
2.1.2 The behavior of modals: I <sup>o</sup> as a raising category	31
2.1.3 Reconstruction effects	32
2.1.4 VSO order: against the Spec-IP generation of subjects	33
2.1.4.1 Excursus: Old Irish and the ISH	36
2.1.4.1.1 The Old Irish Verbal System	37
2.1.4.1.2 Verb movement to I <sup>o</sup> and C <sup>o</sup>	38
2.1.4.1.3 Preverbs	39
2.1.4.1.4 Object enclitics	42
2.1.4.1.5 Subjects in Spec-IP	43
2.1.5 Conclusion	45
2.2 Subjects in Expanded Infl	45
2.2.1 Tense and modals as raising categories	47
2.2.2 Subject trace in VP: Huang (1993)	48
2.2.3 Complement to causative “have”	49
2.2.4 Against generation in AgrOP	52
2.2.5 Conclusion	54
<b>Chapter 3: VPs, I-syntax and external arguments</b>	<b>55</b>
3.1 In support of stacked structures	56
3.1.1 Overt object movement and ECM	58
3.1.2 Overt object movement in simple clauses: the adjacency condition	61
3.1.3 Quantifier float and the base position of objects in Japanese	69
3.1.4 Consequences of adopting stacked structures	70
3.1.4.1 Case Positions and $\theta$ -positions	71
3.1.4.2 Getting the external/internal distinction from the syntax	72
3.1.4.3 External vs. internal VPs and adverb type: Bowers (1993)	77
3.1.5 The story so far	81
3.2 Events, agents and verbs	83
3.2.1 L-syntax: deriving the lexicon	83
3.2.1.1 How many theta-roles? Hale and Keyser's question	83
3.2.1.2 VoiceP, unaccusatives and agents	86
3.2.1.3 “Kill” as “cause to die”: event structure	87

3.2.2	Lexical Japanese causatives: l-syntax and Late Insertion	89
3.2.2.1	“Lexical” vs. “analytic”: interpreting V+sase	90
3.2.2.2	The “Elsewhere” rule: Late Insertion	92
3.2.2.3	Lexical causatives: realizing CAUSE	96
3.2.2.3.1	More evidence for Late Insertion	100
3.2.3	EventP as a delimiter: why non-compositional interpretation?	101
3.2.4	Properties of EventP	102
3.2.4.1	“Primitives”: A, N, P	102
3.2.4.2	The “syntax” of l-syntax	104
3.2.5	“Give” = CAUSE x HAVE y	106
3.2.5.1	The preposition HAVE	107
3.2.5.2	“Have” = BE + HAVE	108
3.2.5.3	Existentials, possessives and locatives: Freeze (1992)	111
3.2.5.4	Definiteness vs. HAVE	113
3.2.5.5	Languages without HAVE	115
3.2.5.5.1	Irish	115
3.2.5.5.2	Diné	117
3.2.5.5.3	Tagalog	119
3.2.5.6	Languages with HAVE	122
3.2.5.6.1	English	122
3.2.5.6.2	Japanese	122
3.2.5.6.3	Georgian	125
3.2.6	Some implications	126
3.2.6.1	Auxiliaries:	126
3.2.6.2	Causative and experiencer have	128
3.2.6.3	Other possible complements of EventP: CP, TP	131
3.2.6.4	VP adverbials revisited	132
3.2.7	Conclusion	133

## **PART II: LICENSING** 135

### **Chapter 4: Realizing case** 137

4.1	Case Theory	138
4.1.1	Case and the VP-Internal Subject Hypothesis	141
4.1.2	An Agr-based Case Theory	142
4.2	The case of the Icelandic experiencer	143
4.2.1	Dative-nominative experiencer subject constructions	143
4.2.2	Case in experiencer subject constructions	144
4.2.3	Structural nominative	145
4.2.4	Nominative in T <sup>0</sup> ?	147
4.2.4.1	Negative polarity items	147
4.2.4.2	Finiteness and tense	148
4.2.5	The Mechanics of case	150
4.3.	Japanese causatives	152
4.3.1	The problem	154
4.3.1.1	Case alternations and the make/let distinction	154
4.3.2	“Make” vs. “Let” readings: syntactic facts	156
4.3.2.1	Biclausal -sase-	156
4.3.2.2	Passivization of “make” vs. “let”	157
4.3.2.3	Construal of “agent-oriented” adverbs	157
4.3.3	The analysis, part I: clause-bound case-marking	158
4.3.3.1	Prepositional vs. case-marking -ni	160

4.3.3.2	The MCP and the “make” causative	161
4.3.4	The analysis, part II: syntactic differences	162
4.3.4.1	The “let” causative: scope facts	165
4.3.4.2	The “agent-oriented” adverbs	165
4.3.5	Causee as matrix object	167
4.3.5.1	V+Cause—syntactic or morphological?: Terada	167
4.3.5.2	Passive and Causative	169
4.3.6	Scope of the causee: “make” causative	170
4.4	Conclusion: realization of case recap	171

## **Chapter 5: Case, the EPP, and having experiences** 173

5.1	Burzio's Generalization and the EPP	174
5.1.1	Does Burzio's generalization exist?	174
5.1.2	Case-assignment: no abstract case required	177
5.1.2.1	ECM and PRO: Activating Agr	178
5.2	Movement restrictions: Equidistance and Leapfrogging	180
5.2.1	Holmberg's Generalization	181
5.2.2	OS for case?	182
5.2.3	TEC+OS and dative-nominative constructions	183
5.2.4	A Split-VP and Equidistance	187
5.3	PRO and the EPP	189
5.3.1	Control vs. ECM revisited	189
5.3.2	Irish and the EPP	192
5.4	Auxiliaries, undercover agents, and other psychological problems	193
5.4.1	Mandatory agents and transitive verbs	194
5.4.2	Implicit agents and causative and auxiliary HAVE	196
5.4.3	HAVE and dative-nominative constructions diachronically	199
5.4.3.1	Irish psychological predicates	201
5.4.3.2	Psych predicates in other HAVEless languages	202
5.4.3.2.1	Diné: “subject-verb idioms”	203
5.4.3.2.2	Tagalog: a psychological problem	204
5.4.3.3	Getting HAVE	206
5.4.3.4	Incorporation and psych predicates	208
5.5	Conclusion	210

## **Appendix to Chapter 5: Dative-nominative constructions** 211

A.1	Icelandic	212
A.2	Japanese	215
A.3	Kannada	218

## **Chapter 6: Concluding Remarks** 221

## **Bibliography** 227





## 1 *“Subject”*

---

In grade school, the maxim “every sentence must have a subject” is a staple of the English grammar class. The intuition behind this pronouncement has made its way virtually unchanged into much theoretical linguistics: relational grammar has its “Final-1 Law”, lexical-functional grammar appeals to the “subject condition”, principles and parameters theoreticians posit the “Extended Projection Principle”. These theory-specific versions of the above descriptive statement essentially stipulate that there is condition on every clause such that some relation or position must be borne or filled by an NP that is in some sense a “subject” (or possibly, that there must be a relation or position in every clause such that an NP that fills it is a “subject”). It has long been recognized, however, that the set of properties that characterize a canonical subject in a highly “subject-prominent”<sup>1</sup> language

---

<sup>1</sup>This terminology is used in Li (1976).

cannot be linked to a single position—it is simply not the case that there is a one-to-one mapping of “subject” properties to some universal syntactic position. Even within a given language, many constructions exist in which the properties usually attributed to a canonical subject seem to be scattered between two or three NPs. Below, we will see some examples of this type of mismatch in English and Japanese. Essentially, it seems as though canonical subjects must collect their typical properties from several sources, (at least some of) which can be selectively unavailable to a single NP in different constructions or in different languages. Such variation will result in varying degrees of subject “prominence”. This basic approach to the notion “subject” is that adopted in Li (1976).

Two interesting questions then arise:

a) What are the different “sources” of these properties—how can each of these properties be syntactically characterized?

b) Why, if these properties have separate provenance, do they exhibit such a strong tendency to converge on one “subject” NP, cross- and intra-linguistically?

The first of these questions has been the topic of much investigation, although not necessarily in the formulation used here: essentially it boils down to the question of what “subject tests” are testing for. Many of these individual tests have been discussed extensively in the literature—“subject-oriented” anaphora, nominative case, Control, etc. have each a substantial body of literature dealing with them. It is clear from a cursory glance (which we will take below) that they do not all refer to or result from the same syntactic configuration. The second question has not received much attention; its corollary is the question of what parameters or interacting systems permit or require variation in convergence, resulting in greater or lesser degrees of subject prominence.

The question of whether or not the notion of a “subject” is a coherent primitive of the language faculty has long been answered in the negative by Principles and Parameters theoreticians. As noted above, the set of elements broadly characterized as “subjects” with

respect to various tests is not a uniform one—that is, many of the properties that have been assumed to pick out something that can be generally referred to as a subject in fact pick out different elements. Below, as a preliminary to the main discussion, I outline some well-known facts that indicate that the cluster of properties often attributed to subjects in English appear on closer examination to be associated with a variety of positions in a clause. Some of these properties include triggering verbal agreement, receiving nominative case, anteceding “subject-oriented” anaphors, being outside the scope of existential closure and sentential negation (for NPI licensing), being an “external argument”, being suppressed in passive constructions or raised in raising constructions, controlling PRO, etc. Many NPs traditionally described as subjects have all of these properties, but many constructions (inversion, serial-verb, ECM, etc.) exist that allow us to tease them apart and determine what each of these “subject-like” properties can be attributed to.

### 1.1 A syntactic “subject” position: agents vs. “subjects”

The basic dichotomy between notional and syntactic “subjects” has been recognized since the first attempt to characterize the passive construction. A pair of sentences like those in 1) below can characterize the same situation, but the syntactic structures of the two are transparently quite different.

1.
  - a) Opus sniffs the dandelions.
  - b) The dandelions are sniffed by Opus.

Both sentences describe a (habitual) situation in which Opus is inhaling with his nose in the immediate vicinity of at least two dandelions. The agent and the action described in each case is the same. The two sentences, however, differ in that *Opus* appears in preverbal position and triggers agreement with the tensed verb in 1a), while *the dandelions* appears in preverbal position and triggers agreement with the tensed verb in 1b). The preverbal, agreement-triggering position in English is generally referred to as “subject” position, so

the syntactic subject of 1a) differs from the syntactic subject of 1b), although the performer of the action described (thematic “agent”) remains the same.

*Opus* in 1a) and *the dandelions* in 1b) share other syntactic properties. Below is a catalogue of things they have in common, essentially a list of some of the properties of syntactic subjects in English:

2.

Property	Active example	Passive example
a) Occupies the preverbal position	<i>Opus</i> [ <sub>v</sub> sniffed] the dandelion	<i>The dandelion</i> [ <sub>v</sub> was sniffed]
b) Triggers agreement with the finite verb	<i>Opus</i> sniffs the dandelions Opus-3s sniff-3s	<i>The dandelions</i> were sniffed The dandelions-3pl be-3pl
c) Bears nominative case	<i>He</i> (* <i>him</i> ) sniffed the dandelions	<i>They</i> (* <i>them</i> ) were sniffed
d) Raises in “raising” constructions	<i>Opus</i> seemed to sniff the dandelion	<i>The dandelion</i> seemed to be sniffed
e) Inverts with the auxiliary in matrix questions	Did <i>Opus</i> sniff the dandelions?	Were <i>the dandelions</i> sniffed?
f) Bears accusative case in ECM constructions	Bill believed <i>Opus</i> to have sniffed the dandelion	Bill believed <i>the dandelion</i> to have been sniffed
g) Is disallowed in infinitive constructions	(* <i>Opus</i> ) To sniff dandelions is sublime	(* <i>The dandelion</i> ) To be sniffed is its <i>raison d’être</i> .
h) Can be controlled	<i>Opus</i> wanted [ <i>PRO</i> to sniff dandelions]	<i>The dandelions</i> wanted [ <i>PRO</i> to be sniffed]
i) Negative Polarity Items in subjects are not legitimately licensed by sentential negation	* <i>Any penguin</i> doesn’t sniff dandelions	* <i>Any dandelions</i> aren’t sniffed every day.
j) Triggers a “that-trace” effect in embedded clauses.	* <i>Which penguin</i> did Bill say that <i>t</i> sniffed dandelions?	* <i>Which dandelions</i> did Bill say that <i>t</i> were sniffed?
k) Can undergo “Subject Ellipsis” (appears outside conjoined VPs, apparently “deleting under identity”; contrast with the unavailable “Object Ellipsis”)	Bill says <i>Opus</i> <sub>i</sub> sniffed dandelions and also <i>e</i> <sub>i</sub> ate sardines (*Bill says Binkley hit <i>Opus</i> <sub>i</sub> and Milo kissed <i>e</i> <sub>i</sub> )	Bill says <i>Milo</i> ate pickles and <i>e</i> <sub>j</sub> was given the dandelion. (*Bill says the dandelion was given <i>Milo</i> <sub>i</sub> and <i>Opus</i> kissed <i>e</i> <sub>j</sub> )
l) Is stranded in VP-preposing constructions	Bill said <i>Opus</i> would sniff the dandelion, and [ <sub>vp</sub> sniff the dandelion] <i>Opus</i> did.	Binkley said the dandelions would be sniffed and [ <sub>vp</sub> sniffed] <i>the dandelions</i> were.
m) Creates a strong violation when extracted across a Wh-Island (compare with object extraction)	* <i>Who</i> did Bill ask why Milo said <i>t</i> sniffed the dandelions? (* <i>What</i> did Bill ask why Milo said <i>Opus</i> sniffed <i>t</i> ?)	* <i>What</i> did Bill ask why Binkley said <i>t</i> was given Milo? (* <i>Which</i> blond kid did Bill ask why Binkley said the dandelions were given <i>t</i> ?)
n) Allows a resumptive pronoun in Subjacency environments (for English speakers who use them)	The guy <sub>i</sub> that I don’t know who he <sub>i</sub> is ... *The guy <sub>i</sub> that I didn’t know who <i>Opus</i> hit him <sub>i</sub>	The dandelion <sub>i</sub> that I didn’t know that it <sub>i</sub> was sniffed... *The dandelions <sub>i</sub> that I didn’t know that <i>Opus</i> sniffed them <sub>i</sub> ...
o) C-commands the rest of the clause as demonstrated by, e.g. binding principle A	<i>Opus</i> sniffed <i>himself</i> .	<i>The two bunches of dandelions</i> were placed next to <i>each other</i> on the table.

From the above, it seems clear that whatever syntactic configuration produces any of the above effects cannot be straightforwardly linked to the thematic role of the NP that occupies it<sup>2</sup>. I therefore summarily adopt the stance that syntactic “subject” properties result from a given syntactic configuration, and links between the “canonical” subject position and “thematic role” of the NP that occupies it follow from syntactic structure, and are not directly encoded in universal grammar<sup>3</sup>

The question of “subjecthood” is then a syntactic one. Can it be the case that all the above properties result from one syntactic configuration? Just prior to work in the mid/late 1980s (Zagona (1982), Koopman and Sportiche (1985, 1991), Speas (1986), Kitagawa (1986), Fukui and Speas (1986), Contreras (1987), Kuroda (1988), Sportiche (1988), Rosen (1989), Woolford (1991), Huang (1993) *et al...*) subjects were assumed to occupy the specifier of IP, in a configuration like that shown below:

3.

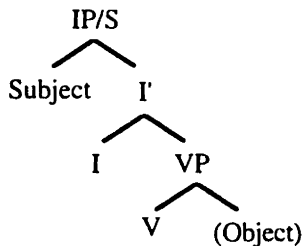

It is thus at least possible to assume that all the properties of subjects shown above are properties that result from being in the specifier of IP—a preverbal position in English.

<sup>2</sup> The key word here is “straightforwardly;” much work has been devoted to exactly this problem. Many have argued that although there is no direct mapping of “agent” arguments to this syntactic position, the additional notion of a thematic hierarchy might allow a characterization of mapping to the preverbal position along the following lines: “the argument receiving the highest theta-role appears in preverbal position”. This type of approach inevitably requires some complications, however. In double-object constructions, either object can become the subject of a passive:

- i) Lucy was given the blanket (by Linus)
- ii) The blanket was given Lucy (by Linus)

Some special notion (e.g. stipulating that the theta-roles borne by “the blanket” and “Lucy” are tied in the thematic hierarchy) is needed to allow the appearance of both of these constructions. The attraction of a syntactic approach to the alternation, as we will argue extensively below, is that under such an approach to passive constructions (and indeed to argument structure in general) no additional notions of thematic hierarchy or rules of lexical alternation are necessary. See discussion in chapters 4 and 6 especially.

<sup>3</sup>In fact, in later chapters we will follow Hale and Keyser (1991) in claiming that apparent theta-roles are in fact syntactic in nature, rather than lexical — they can be syntactically defined .

However, it is transparently the case that NPs that are not in this configuration (at least when pronounced) exhibit some of the above properties. Further, two different XPs in the same sentence can exhibit different subsets of the above properties; presumably, two different XPs could not be said to both occupy the single Spec-IP position.

## 1.2 “Subject” property mismatches

For example, in existential “there” constructions, the element that triggers agreement with “to be” appears post-verbally, rather than preverbally, in 4) below:

4. There were *scary political posters* in the meadow.

In locative inversion constructions, not only does the nominative, agreement-triggering argument appear post-verbally, the preverbal locative PP triggers a “that-*t*” effect, as noted by Bresnan (1977) and as can be seen in 5)-7):

Case:

5. ?<sup>4</sup>Into the meadow strolled *he* / (*\*him*)

Agreement:

6. Into the meadow strolls *the basselope* every day at noon

“that-*t*” effect:

7. a) \**Under which bridge* did you say that *t* lives a troll?  
b) *Under which bridge* did you say *t* lives a troll?

The locative argument also appears to raise in subject-raising constructions, as in 8) below:

8. Into the meadow seemed to stroll the *basselope*

Some of the other “subject” properties noted above also seem to hold of the PP argument. Although the judgments are somewhat difficult, extraction of the inverted PP

---

<sup>4</sup>This example is poor due to the “presentational focus” requirement on subjects in locative inversion constructions; locative inversion is used when the inverted subject is being introduced into the discourse. Pronouns are infelicitous in this context as they must refer to some previously salient element in the discourse. However, insofar as any pronoun is good, there is a definite contrast between the nominative and accusative forms.

from within a Wh-island produces a violation comparable to that produced by subjects (9a), although extraction of the non-inverted PP does not (9b), and noticeably worse than that produced by objects (9c):

9. a) \*Into which meadow did Milo ask why Binkley said *t* strolled the basselope?  
b) ??Into which meadow did Binkley ask why Milo said the basselope strolled *t* ?  
c) ??Which dandelion did Binkley ask why Milo said Opus sniffed *t* ?

Finally, the inverted subject and the following verb form a constituent, in that so-called “subject ellipsis” (Zaenen et al (1985); see the Appendix to chapter 6); in more recent terminology Across-The-Board extraction from conjoined VPs) applies to the inverted locative PP but not to the postverbal subject (10):

10. a) Into the meadow [strolled Rosebud] and [ran Milo].  
b) \*[Into the meadow strolled Rosebud] and then [into the barn sauntered]

The discussion above is merely intended to indicate that even in a language with relatively fixed word order and a great degree of “subject prominence” like English, characterizing the notion of a syntactic subject requires a more articulated analysis than “occupies the specifier of IP”. More will be said about (some of) these constructions below. If the net is cast wider than English, we see that many language-particular tests that are considered to identify canonical “subjects” do not necessarily pick out the same set of elements as other subject-identifying tests. We will just briefly describe a few of these mismatches that will be explored later, and then enter into more serious consideration of some of the questions raised above.

In many languages (Japanese, Dutch, German, Malagasy, Russian, Kannada...), there is/are an anaphoric element(s) that can be characterized as “subject-oriented”—that is, can only have as antecedent an NP that has some characteristic usually associated with subjects. In Japanese, *zibun* is such an anaphor. In 11a) it is coreferent with the subject

“Dennis”; in the ungrammatical 11b) it is unable to be coreferent with the object “Andy Capp” (see, e.g. Kitagawa (1986)).

11. a) Dennis<sub>i</sub>-ga inu-o zibun<sub>i</sub>-no oya-no mae-de sikat-ta  
*Dennis-N dog-A self-G parents-G in-front-of scold-Pst*  
 “Dennis scolded (his) dog in front of self’s parents.”
- b) \*Okusan-ga Andy Capp<sub>i</sub>-o zibun<sub>i</sub>-no oya-no mae-de sikat-ta  
 \*wife-N Andy Capp-A self-G parents-G in-front-of scold-Pst  
 “(His) wife scolded Andy Capp in front of self’s parents.”

Japanese, like English, is a Nominative-Accusative language; its subjects are typically marked with the nominative marker *-ga* (if it is not pre-empted by the Topic marker *-wa*). Interestingly, subjects which are not marked with nominative can still antecede *zibun*, indicating that such nominative marking is not dependent on whatever “subject” properties *zibun* requires in its antecedent. Some (experiencer) subjects can be marked with the dative marker *-ni*; they can still antecede *zibun*, while their nominative-marked objects cannot. This is seen in 12) below: a) shows successful coreference with the dative subject *Calvin*, while b) shows the inability of the nominative object *Hobbes* to corefer with *zibun*:

12. a) Calvin<sub>i</sub>-ni Hobbes-ga zibun<sub>i</sub>-no oya-no mae-de sikar-e-na-i  
*Calvin-D Hobbes-N self-G parents-G in-front-of scold-pot-neg-pres*  
 “Calvin<sub>i</sub> can’t scold Hobbes in front of self<sub>i</sub>’s parents”
- b) \*Calvin-ni Hobbes<sub>i</sub>-ga zibun<sub>i</sub>-no oya-no mae-de s ikar-e-na-i  
*Calvin-D Hobbes-N self-G parents-G in-front-of scold-pot-neg-pres*  
 “Calvin can’t scold Hobbes<sub>i</sub> in front of self<sub>i</sub>’s parents

*Zibun* can, however, be coreferent with embedded subjects in a biclausal construction like the causative. Although the embedded subject is receiving accusative case and the embedded clause is apparently completely lacking inflection, coreference with *zibun* is still possible:

13. Calvin-wa Hobbes<sub>i</sub>-o jibun<sub>i</sub>-no kuruma-de paatii-e ik-ase-ta  
*Calvin-Top Hobbes-ACC self-GEN car-by party-to go-Cause-Past*  
 “Calvin made Hobbes<sub>i</sub> go to the party in self<sub>i</sub>’s car.



Another property associated with subjects in Japanese is the ability to trigger “subject honorification” agreement. When the subject of a sentence is a person worthy of respect, the affix *-ni-* can be attached to the verb. (Objects can induce honorific marking on the verb, but the marking takes a different form.) An example with a nominative subject can be seen in 14a), and with a dative subject in 15a). Note that the nominative object in 15b) cannot induce honorific subject marking, like the accusative object in 14b).

14. a) Yamada-sensei-ga sono gakusei-o o-maneki-ni-nat-ta  
*Yamada-Prof-N that student-A invited-Hon-Past*  
 “Professor Yamada invited that student”
- b) \*Sono gakusei-ga Yamada-sensei-o omaneki-ni-nat-ta  
 \**that student-N Yamada-Prof-A invited-Hon-Past*  
 “That student invited Professor Yamada”.
15. a) Yamada-sensei-ni sono gakusei-ga o-wakari-ni-nar-ana-katta  
*Yamada-Prof-D that student-N understand-Hon-Neg-Past*  
 “Professor Yamada didn't understand that student.”
- b) \*Sono gakusei-ni Yamada-sensei-ga o-wakari-ni-nar-ana-katta  
 \**that student-D Yamada-Prof-N understand-Hon-Neg-Past*  
 “That student didn't understand Professor Yamada”.

However, although *zibun* can be anteceded by an embedded subject of a causative, subject honorification cannot be induced by such a subject<sup>5</sup>, as can be seen in 16) below:

16. \*MIT-ga Yamada-sensei-ni o-hasiri-ni nar-ase-ta.  
*MIT-N Yamada-Prof-D run-Hon-Cause-Past*  
 'MIT let Professor Yamada run.'

Whatever constraints govern the distribution of subject honorification, then, the embedded subject in 17) above does not satisfy them (again, see the Appendix to chapter 6 for similar facts and chapter 6 itself for some general discussion of dative-nominative constructions).

Similar mismatches between “subject”-specific case-marking, agreement, word order, extraction possibilities, anaphora, etc. exist in many other languages (if not all other

---

<sup>5</sup>Kitagawa (1986) claims that such examples are felicitous when supported by an additional honorific verb *sasiage-ta*, ‘respectfully give’; however, for my informants, even such support cannot save the above construction.

languages). A configurational account of these mismatches seems to require some notion of multiple subject positions, for example, the VP-internal subject hypothesis (henceforth the ISH). The question then becomes, which positions are relevant for satisfying which of the various constraints on well-formedness that are relevant to subjects—which position, when filled, satisfies Chomsky’s (1986) “Extended Projection Principle”? Is this the same position in which abstract nominative Case is checked? Are either of these positions the place where the subject is base-generated or receives its theta-role? Which of these positions is responsible for subject-object extraction asymmetries? By the end of this thesis, some of these questions should be answered, and a precise characterization of at least some “subject” properties should have been achieved. Two properties in particular will be examined in detail. First, we will examine the structural properties associated with “external arguments”, that is, the question of where thematic subjects (as opposed to clausal subjects) are base-generated. Drawing on evidence from Japanese lexical causatives, I argue for a “split-VP” structure, in which true external arguments (Agents, Causers) are generated in the specifier of a projection which marks the introduction of an event argument (hence termed EventP). Below EventP are case-checking positions for underlying objects and indirect objects (“internal arguments”) and the projection in which internal arguments are base-generated (“BaseP”). This is the subject matter of chapters 2 and 3. Secondly, the question of morphological nominative case is considered. Nominative marking on an NP is typically taken to be an indicator of subjecthood, yet there are constructions (as we have seen above) where a nominative-marked argument appears at least superficially to be in object position. Such nominative objects in Icelandic are examined in detail, and a mechanism for assigning morphological case is proposed which modifies standard assumptions about connecting morphological case strictly to certain structural positions. Given such modification, the question of NP-licensing is re-examined, with an eye to dispensing with abstract case entirely; the apparent effects of abstract case assignment (and, incidentally, Buzio’s Generalization) are seen to be the result of the

interaction of the mechanism governing morphological case assignment with the Extended Projection Principle. This is the subject matter of Chapters 4 and 5. The complete clausal architecture which is adopted by the end of the thesis can be seen below in 17); Part I deals essentially with that portion of it which includes Event P and its complements, and Part II deals mostly with that portion which includes the inflectional projections dominating EventP.

### 17. The Big Picture

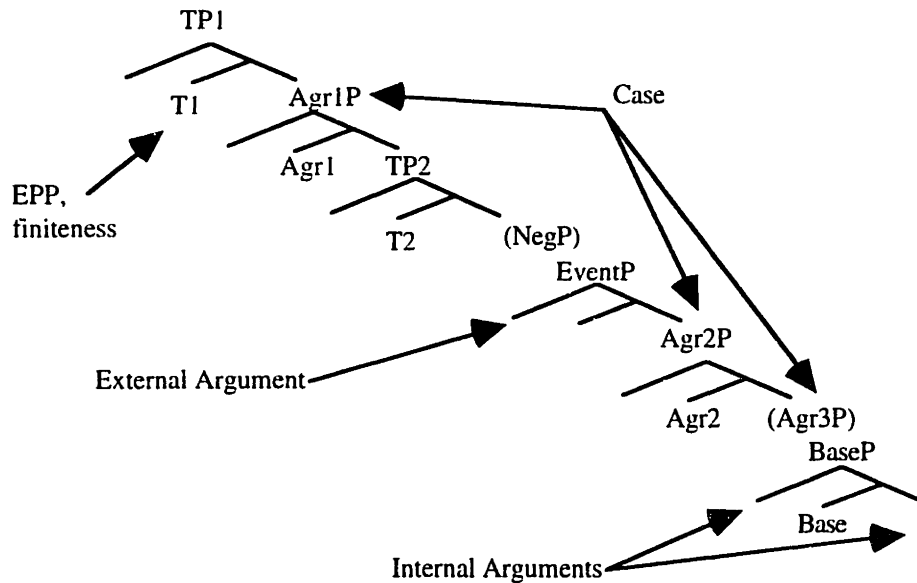

### 1.3 Conclusion

To sum up, then, we have seen that the properties that are commonly associated with the notion “subject” need to be characterized as deriving from varied sources. Constructions involving locative inversion or experiencer predicates can contain elements that have properties associated with some of the sources, but not with others. As outlined above, we will examine in particular two of these properties with an eye to establishing their exact character and distribution, that of being an “external argument”, and that of bearing nominative case—that is, “subject” properties relevant at the LF and PF interfaces respectively. To begin, we consider some of the literature associated with subject projection

and theta-assignment, discussing the VP-Internal Subject Hypothesis. This is the subject matter of Chapter 2.

# PART I: PROJECTION

---



## 2 *Where don't they come from?*

---

If the demonstrably separate independent properties discussed in chapter 1 are to receive a configurational account, presumably multiple positions/configurations will need to be posited to account for each non-overlapping subject property. That is, different properties will result from different positions or configurations. The VP-internal subject hypothesis provides an additional subject position, which presumably could account for some of the observed dichotomies in the realization of subject properties, and will be the starting point for our investigation here. In the first part of this chapter, I go over the primary purely syntactic arguments for the ISH that have been put forward in the literature since its introduction. In addition, I extensively develop the argument from VSO order using data from Old Irish. In the second half, I consider the implications of the “articulated Infl” adopted in most current Minimalist work for the ISH, given the proliferation of possible subject positions resulting from the positing of additional projections between the

VP and the topmost Infl projection. In particular, I consider the possibility that Spec-TP is a possible position for the base-generation of subjects.

## 2.1 *Against Subjects in Spec-IP*

### 2.1.1 *Conjunction of passives and actives: the CSC*

McNally (1992) and Grimshaw and Burton (1992) succinctly demonstrate that assuming that Spec-IP is a derived position for subjects resolves a potential conflict between assuming ATB movement for coordinated structures and the possibility of coordinating active and passive VPs below the same subject.

Assume a standard treatment of the passive whereby the derived subject (an underlying object) is base-generated inside the VP and moves to Spec-IP during the derivation. Coordination of a passive VP (with the trace of that movement inside it) and an active VP, whose subject is generated in Spec-IP, (illustrated in 1b) below) could then be problematic.

The conjunction of two phrases, one with and one without a subject trace should violate the Coordinate Structure Constraint (Ross (1967) (assuming that A-movement is subject to the CSC<sup>1</sup>) as NP in Spec-IP will have to bind a trace in one conjunct, but not the other.

---

<sup>1</sup>Marantz (p.c.) points out that no one has previously argued that A-movement should be subject to the CSC; without such a demonstration, this argument loses much of its force.



1.

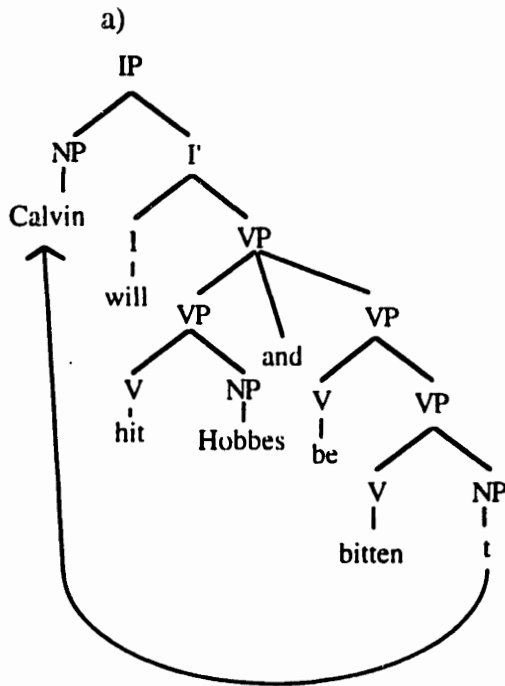

b) Calvin will hit Hobbes and be bitten

However, if the subject ("Calvin") is generated within the VP in active sentences as well as passives, movement to Spec-IP will take place from tSpec-VP both conjuncts and the Coordinate Structure Constraint will be satisfied<sup>2</sup>. The relevant structure would look like 2) below:

---

<sup>2</sup>Williams (1992) proposes an account whereby theta-relations are read off the structure after derivations are complete; on such an approach, this argument is not relevant. There are other arguments against such an approach (see below, and sections 3.1.2-3 in Chapter 3).

2.

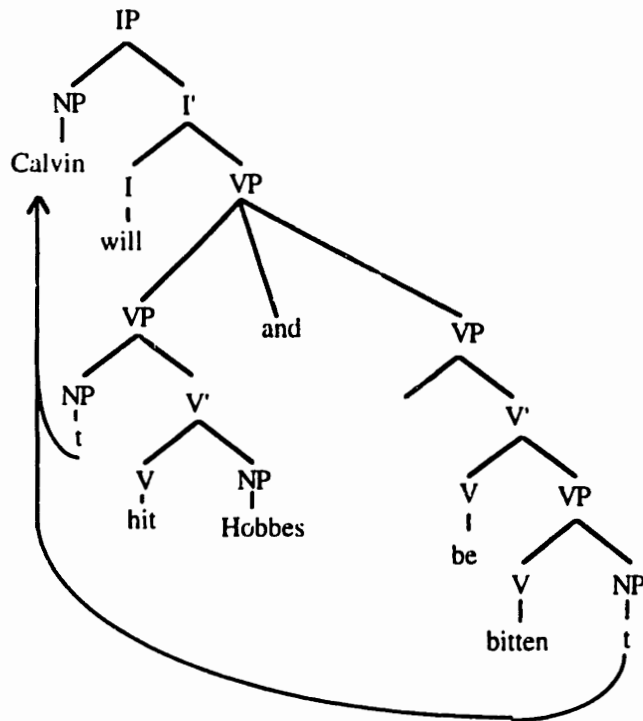

It is worth noting, as pointed out in McNally, that there are differences in interpretation between coordinated VPs, with a single quantificational subject, and coordinated IPs with coreferential subjects, where the first is quantificational and the second projomial (McNally: 338):

3. a) Every student passed the test and was praised for it.  
 b) Every student passed the test and s/he was praised for it.

In 3a) the pronominal subject cannot be interpreted as bound by the quantifier, but the implied subject of the VP in 3b) must be so bound. No approach in which the second conjunct contains an empty pronominal category coindexed with the argument in Spec-IP can therefore be entertained.

### 2.1.2 The behavior of modals: I° as a raising category

Williams (1983), Kitagawa (1986), Stowell (1991), and Koopman and Sportiche (1991) point out that elements that appear in I° exhibit the same behavior as a raising verb. The modal *will* (by assumption, in I°) behaves in the same way as raising verb *seems* in the following two respects (similar facts are seen with, e.g. the *do* of *do*-support):

4.

a) Neither modal *will* nor the verb *seems* assign an external theta-role:

\*Lucy will Charlie Brown feed Snoopy.

\*Lucy seems Charlie Brown to feed Snoopy

b) The raised subject of *seems* can be selected for by its embedded predicate, as can the subject of *will*:

weather *it*:      It will be raining  
                         It seems to be raining

idiom chunks: The shit will hit the fan  
                         The shit seems to have hit the fan

If subjects were generated in Spec-IP, they argue, such parallels with the behavior of raising verbs are not predicted. Either selectional restrictions between the subject and the embedded predicate could not be maintained and selectional restrictions between the content of I and the subject might be expected to exist, or a non-local notion of “selection” needs to be introduced whereby embedded predicates can constrain their subjects long-distance. Koopman and Sportiche maintain that the theory of selection and theta-assignment can remain less complex and more elegant if external arguments are base-generated internal to the projection of V, which allows for direct selection by V of all arguments.<sup>3</sup>

Kitagawa<sup>4</sup> (1986) and Koopman and Sportiche (1991) also argue that dual scope properties of modals and tense with respect to the interpretation of indefinite subjects

---

<sup>3</sup>However, see the discussion of selection of subjects by V in section 3.3.2 below.

<sup>4</sup>Kitagawa argues that English is underlyingly VOS, where Spec-VP is right adjoined. He takes sentences like i) below as examples of unraised subjects, where the CP coindexed with the expletive *it* is to the right of the rest of the VP material:

i) It<sub>i</sub> [<sub>VP</sub> bothers me [that he hasn't arrived yet]<sub>i</sub> ]

Kitagawa (1986): 239

parallel the scope properties of raising verbs. The possibility of an embedded scope reading for subjects of raising verbs is argued in May (1985) to result from the presence of the trace of the subject in the embedded clause; along the same lines, the possible embedded scope of subjects with respect to modals is argued to result from the presence of a subject trace in the VP complement of I. The possibility of the embedded scope interpretation is hypothesized to result from interpretation of the subject in its base position at the tail of the A-chain. The relevant examples are in 5) below:

5.

a) A tiger seemed *t* to have eaten the tuna.

Wide scope: *There is a tiger such that it seems to have eaten the tuna*

Narrow scope: *It seems that a tiger has eaten the tuna*

b) A tiger might *t* have eaten the tuna.

Wide scope: *There is a tiger that might have eaten the tuna*

Narrow scope: *It might be the case that a tiger has eaten the tuna*

### 2.1.3 Reconstruction effects

Huang (1993) suggests that the ISH allows a straightforward account of reconstruction effects like those in 6) below. In 6a), the anaphor *each other* can be construed with either the matrix subject *they* or the embedded subject *we*. The former reading presumably results from reconstruction to the intermediate trace position, where the anaphor can be locally bound by the matrix subject. In 6b), however, *each other* in the fronted VP can only be construed with the embedded subject—a surprising result, given that the intermediate trace is a possible reconstruction site in 6a).

6. a) [<sub>NP</sub> Which friends of each other<sub>*t<sub>j/k</sub>*</sub> ]<sub>*i*</sub> did they<sub>*j*</sub> say *t<sub>i</sub>* that we<sub>*k*</sub> could talk to *t<sub>i</sub>*?

b) [<sub>VP</sub> Talk to friends of each other\*<sub>*t<sub>j/k</sub>*</sub>]<sub>*i*</sub> they<sub>*j*</sub> said *t<sub>i</sub>* we<sub>*k*</sub> could not *t<sub>i</sub>*.

Huang (1993) points out that this contrast has a simple explanation under the ISH.

If subjects are generated in Spec-VP, there will be a trace of the embedded subject in the

---

I will not argue extensively against this analysis here, see, however, the discussion of similar examples with respect to Case theory in Chapter 6 below.

fronted VP constituent in 6b), which will serve as the binder of the anaphor no matter where in the clause the VP is interpreted.<sup>56</sup>

#### 2.1.4 VSO order: against the Spec-IP generation of subjects:<sup>7</sup>

As noted in Koopman and Sportiche (1991) and also in Woolford (1991), if subjects are generated in Spec-IP, the existence of languages exhibiting VSO order is puzzling. The null hypothesis is that languages do not vary with respect to where their subjects are generated. If subjects are generated in Spec-IP in VSO languages, VSO order must be derived either via movement of the verb to some higher position, e.g.  $C^{\circ}$ , or via downward movement of the subject. On the other hand, if subjects are generated in some position below Spec-IP, VSO order can result from movement of the verb to  $I^{\circ}$  (as attested in, for example, French; see Pollock (1989)) while the subject and object remain in situ (or undergo partial movement, as argued for Irish in Bobaljik and Carnie (1994)). Cross-linguistic word order variation then will result from logically possible combinations of parameters of movement of the verb and the subject: in French, both verb and subject move; in English, the subject moves while the verb remains in the VP, and in Irish (and possibly other VSO languages) the verb will move while the subject remains in situ. (A fourth possibility is that both the verb and its arguments remain in situ at S-structure, which we will not discuss here).

---

<sup>5</sup>In a recent article in *LJ*, Takano (1995) reevaluates Huang's analysis and reworks it to include a broader range of data. His conclusion that this type of fact provides support for the ISH remains the same as Huang's, however, and I hence do not elaborate. The interested reader is referred to Takano's article for discussion.

<sup>6</sup>Marantz (p.c.) points out that Huang's argument holds not only for VPs but for all predicate types, given his particular view of binding theory; that is, that *any* predicate on Huang's account should have a trace of its subject within its maximal projection.

<sup>7</sup>I would like to thank Andrew Carnie for much crucial discussion and commentary on material in this section. Much of this material is taken directly from Carnie, Pyatt and Harley (1994); I am greatly indebted to my co-authors for their part in the development of these arguments.

Both the alternative derivations of VSO order outlined above allowing for base-generation of the subject in Spec-IP have been proposed. In order to drive home the argument for the ISH from VSO order, I will argue that for some instances of VSO, at least, neither of the proposed alternatives are plausible, and hence subjects must in some instances, at least, be generated lower than Spec-IP. The two possible sources of VSO order, given base-generation of the subject in Spec-IP are outlined in 7) below:

7. Two possible sources of VSO order:

- i) Subjects are lowered to a position below the verb but before the object
- ii) The verb raises past Spec-IP to  $C^\circ$ .

Both types of analysis of VSO have been proposed, the former in Choe (1987) and Chung (1990), the latter in Emonds (1980), Deprez and Hale (1986), Stowell (1989) and Hale (1989). Either can accommodate subjects base-generated in Spec-IP; however, there are strong arguments against both. For detailed arguments against i), see Carnie (1995). Here I will just note that the theoretical implications of such an approach are extremely undesirable—nowhere else in the theory does Move- $\alpha$  involve downwards movement, leaving an unbound trace. All other things being equal, then, a subject-lower-than-V hypothesis is preferable to i).

I will consider more seriously the proposal in ii), that is, that VSO order results from movement to  $C^\circ$  past Spec-IP, in a type of “weak V2” effect—movement of V to  $C^\circ$  without concomitant movement of a topic XP to Spec-CP as in V2 languages. There are several problems with such an approach to VSO in Modern and Old Irish, which I will elaborate on below.

First, such an analysis might predict that if  $C^\circ$  is filled, as in an embedded clause, V-raising to  $C^\circ$ <sup>8</sup> is unnecessary (as is the case in many V2 languages). This is transparently

---

<sup>8</sup>David Pesetsky (p.c.) points out that this prediction is only necessarily true if verb-movement to C is substitution. On an adjunction story, whether C is filled or not should make no difference to verb-

not the case—the order in embedded clauses in Irish is C°-VSO, not C°-SVO, as pointed out in Koopman and Sportiche (1991). The relevant sentence can be seen in 8) below (data from Carnie (1995)):

8. Ceapaim [ go bhfac:1 sé an madra ]  
 think.PRES.1s [ that see.PST.DEP he.NOM the dog ]  
                   COMP V S O  
 'I think that he saw the dog.'

McCloskey (1992) also advances convincing arguments from the interpretation of sentential adverbials that the verb raises to the left edge of IP and no further in Modern Irish<sup>9</sup>. His arguments are summarized in the footnote below.

movement. The argument from Old Irish, below, however, is not affected by a substitution vs. adjunction approach to V-C movement.

<sup>9</sup> McCloskey (1992b) presents a more complicated argument using the behavior of adverbs showing that the verb is no higher than the left edge of IP in Modern Irish. In English, there is a set of adverbs and adverbial clauses which appear to the right of complementizers but to the left of subjects (data from McCloskey 1992b):

- i) a. That *in general* he understands what is going on seems fairly clear  
 b. It's surprising that *most of the time* he understands what is going on.

These adverbial elements can never appear to the left of the complementizer in English (the following sentence is to be read with the adverb having scope only over the embedded clause, as in the sentence in (i)):

- ii) \*It's surprising *in general* that he understands what is going on.

McCloskey (1992a) argues that the pattern seen above follows from the Adjunction Prohibition of Chomsky (1986):

- iii) *Adjunction Prohibition* (after McCloskey 1992b)  
 Adjunction to a phrase s-selected by a lexical head is ungrammatical.

Under this principle, adverbials are allowed to adjoin to IPs that are complements to C°, a functional head. However, they are forbidden to adjoin to CPs that are selected by a verbal head, a lexical category. In this sense, then, the adverbials shown above in (i) and (ii) can be called IP adjoined adverbs. In contrast, in matrix clauses, where there is no lexical selection of CPs, these same adverbials can appear to the left of a wh-complementizer:

- iv) a. *When you get home*, what do you want to do?  
 b. *Next Christmas*, whose parents should we go see.

In Irish, surprisingly, the order of adverbials and complementizers is different. Adverbials appear to the left of both complementizers and subjects in both matrix and embedded CPs (data again from McCloskey 1992b):

- v)    Adve:b            C     V    S  
 Líonaim d'eagla dá dtógfainn mo radharc dóibh go dtitfinn  
 Fill.1s of fear if lift-1s.cond my sight from.3.s that fall.1.s  
 "I fill up with fear that, were I to take my eyes off, then I would fall"

At first glance, it might appear that Irish lacks the Adjunction Prohibition. However, under closer examination it becomes apparent that this is not the case. Irish does have restriction on adjunction to embedded CPs. Consider the following example (data from McCloskey):

- vi) \*Ni bhfuair siad amach ariamh *an bhliain sin* cé a bh. ag goid a gcuid móna  
 Neg found they out ever that year who C° was prog steal their turf  
 "They never found out who was stealing their turf that year"

In this case, a selected wh-interrogative CP, where you have both a C° and a wh-head marking the left edge of CP, the adverb is illicit to the left of the wh-word. For this case, then, the Adjunction Prohibition holds. This must be accounted for.

A dogged proponent of the V to C° analysis, however, might maintain that the facts in 8 could be captured by CP recursion. We will see below that Old Irish, also a VSO language, can have verbal elements in both I° and C° simultaneously. That this type of construction can not CP-recursion is demonstrated by the facts of object enclisis. The relevance of the construction is clear: if both I° and C° are separately filled, any subject generated in Spec-IP should appear between them, giving C°-S-V-O order. This order is not a possible one in Old Irish. Hence, subjects must be generated in some position lower than Spec-IP.

#### 2.1.4.1 Excursus: Old Irish and the ISH

Old Irish systematically evinces VSO order, as can be seen in 9) below:

9.            Beogidir        in spirit        in corp  
               *vivifies-3s*    *the spirit*     *the body*  
               ‘The spirit vivifies the body’

Interestingly, it appears that Old Irish does have a filled C° requirement, forcing raising to C°, as argued in Carnie, Pyatt and Harley (1994) (CPH henceforth). We will see below that when a verbal particle fills C°, the verb still moves to the left edge of IP, that is, to I, giving C-VSO order.

As in Modern Irish, when the complementizer is filled with a particle, the verb is still otherwise clause initial (following Duffield (1991) I assume that negative and question particles are complementizers):

---

McCloskey suggests that the solution to this paradox is that the adverbs in (v) are IP adjoined, despite the fact they appear to the left of the complementizer. He claims that the C° in Modern Irish lowers to attach to the verb (possibly at PF) because it requires support as a clitic.

The important and relevant conclusion here, however, is that since these adverbs are IP adjoined and they appear to the left of the inflected verb, then the verb must be no higher than the left edge of the inflectional complex. This serves as fairly strong evidence against the weak V2 hypothesis.



10.            Ní                    beir                    in fer                    in claidib  
                  *Neg.C*                    *carries-3s-conj*                    *the man*                    *the sword*  
                  ‘The man does not carry the sword.’

This being the case, Old Irish (like Modern Irish) looks like a language with raising to the left edge of IP in its derivation of VSO order. CP-recursion could conceivably be a possibility for the C°-V order, however. The facts of adjunction of object enclitics, however, make such an analysis unlikely. Before getting to the enclitics, however, we need to examine the Old Irish verbal system somewhat.

#### 2.1.4.1.1      The Old Irish Verbal System

A major difference between Old Irish and Modern Irish lies in the complexity of the verbal system. The morphology of the Old Irish verb includes verbal roots, inflectional endings and a series of preverbal particles. The preverbal particles are of three types: conjunct particles (C), preverbs (P) and object enclitics (E). These particles, the verb, and person/number endings form what is called the “verbal complex”. Excluding the enclitics for the moment, there is a strict ordering to these forms (11b). An example of a maximal verbal complex is given in 12)

#### 11.      Old Irish Verbal Complex

- a)      *Conjunct Particles (C)* - negation, question marker, Cs  
          *Preverbs (P)* - Alters verb meaning, adds perfective aspect  
          *Verb (V)+Subject inflection (S)* - The verb root itself and person agreement.  
          *Enclitics (E)* - Object clitics and relative markers

- b)      C > P > V-S

12.            Ní-m• accai                    (Ní + m + ad + ci+3sng)  
                  *Neg-me•see-3s*                    C                    (E)                    P                    V-S  
                  ‘he does not see me’

Following Duffield (1991), CPH assume the conjunct particle position (C) corresponds to the C° position. This might explain why it must be ordered before the other preverbal particles. In Modern Irish, the conjunct particles form phonological units with overt complementizers (see Duffield 1991 for discussion):

13.            *go* 'that'        +        *ní* 'neg'                    → *nach* 'neg.comp'  
                  *go* 'that'        +        *níor* 'neg-past'            → *nár* 'neg.past.comp'

Similar facts are found in Old Irish, thus CPH assume that the conjunct particles correspond to C° in the older form of the language as well.

#### 2.1.4.1.2        Verb movement to I° and C°

Given this cast of characters, CPH show how certain morphological, phonological and syntactic processes argue for Old Irish having both raising of the verb to the left edge of IP and for the raising of the verb to C°. In Old Irish, the verb and its inflection take two different forms depending upon whether or not these are in absolute initial position. These two forms are called absolute and conjunct (14) (examples taken from Strachan (1984):

- |     |                 |                   |               |
|-----|-----------------|-------------------|---------------|
| 14. | <u>Absolute</u> | <u>Conjunct</u>   |               |
|     | <i>berid</i>    | - <i>beir</i>     | 'he carries'  |
|     | <i>berait</i>   | - <i>berat</i>    | 'they carry'  |
|     | <i>marbfa</i>   | - <i>marbub</i>   | 'I will kill' |
|     | <i>midimmir</i> | - <i>midemmar</i> | 'we judge'    |

The absolute form is used when the verbal root is in absolute first position in the sentence, that is, when the inflected verb is not preceded by any conjunct particles, preverbs or pronouns (15). The conjunct form is used when the verb is preceded by a conjunct particle or a preverb (16).

- |     |                                     |                |                   |            |
|-----|-------------------------------------|----------------|-------------------|------------|
| 15. | <i>Beirid</i>                       | <i>in fer</i>  | <i>in claideb</i> | (Absolute) |
|     | <i>Carries-3s-abs</i>               | <i>the man</i> | <i>the sword</i>  |            |
|     | 'The man carries the sword.'        |                |                   |            |
|     |                                     |                |                   |            |
| 16. | <i>Ní beir/*beirid</i>              | <i>in fer</i>  | <i>in claideb</i> | (Conjunct) |
|     | <i>Neg carries-3s-conj/*abs</i>     | <i>the man</i> | <i>the sword</i>  |            |
|     | 'The man does not carry the sword'. |                |                   |            |

CPH claim that this distribution is definable in a systematic way: when the verb has raised to C° it takes the absolute morphology. When the verb is in any other position (either at the left edge of IP or in verb medial order as in Bergin's Law sentences (see Carney (1976)), it takes the more basic conjunct form. In 15), above, there is no overt complementizer or any other type of preverbal particle. Thus the filled C° requirement

forces the verb to raise from INFL to C° , and we see the absolute form *berid*. In 16), by contrast, the C° has been filled with the conjunct particle *ní* 'neg' thus blocking the raising of *beir* “carries-3s-conj” to C°. The verb raises to the left edge of INFL just like it would in Modern Irish; the inflected verb is thus realized as *beir*.<sup>10</sup>

#### 2.1.4.1.3 Preverbs

CPH also use alternations in the status of preverbs to support their conclusion. The preverbs are the prepositional components of Old Irish compound verbs. For example, take the basic verb *berid* ‘carries’. The addition of a preverbal particle shifts the meaning in unpredictable ways: *as•berid* means “says” (literally “out-carry”). Similar forms, such as *shine/outshine* and *blow/blow up*, are occasionally found in English. In Old Irish, however, the use of these particles is quite common, and help to form a large class of Old Irish verbs. CPH claim that depending upon what other elements appear in the complex, these preverbal particles can behave either as if they were in C° or as if they were combined with the verb in INFL. In particular, it seems that given a compound verb with no conjunct particle, a preverbal particle satisfies the filled C° requirement.

Consider the following compound verb: *as•beir* “says-3s”. This is composed of the preverbal particle *as-* and *beir* “carries”. However, when this verb comes after a conjunct complementizer particle *ní* “neg”, the form of the verb is radically changed. In the example

<sup>10</sup> An interesting variation to this pattern occurs in relative clauses. If the null C is [+wh], then a third form of the verb is used in lieu of the absolute form. For example, in sentence i) below, the inflected verb of the relative clause *gaibid* “grabs” surfaces as *gaibes*, the relative form of the verb.

i)                   Is       oinfer<sub>i</sub> [CP    Ø<sub>i</sub>     gaibes<sub>i</sub>                    [<sub>IP</sub> t<sub>i</sub>    búaid]]  
                   *cop*   *one-man*           *Op.*   *grabs-3s-rel*                                    *victory*  
                   ‘It is one man who grabs victory.’

The differences between the relative form and the absolute form show that the morphology of the absolute is used to signal which null C ([±wh]<sub>j</sub>) is present in the complementizer position. Since the verb forms in absolute initial position vary depending upon what type of complementizer is present in the clause, it lends support to the theory that these verbs are in fact in C. Pesetsky (p.c) points out that such variation in complementizer forms is not uncommon cross-linguistically; Norwegian and Chamorro, among others, exhibit similar facts.

below, the form for “say-1s” is *as•biur* when there is no conjunct particle (17), but *epur* when it follows a conjunct particle like *ní* (18).

17.            *as•biur*            in so  
                  *say-1s this*  
                  ‘I say this.’
18.            *Ní        epur/\*as•biur*    a n-anman        sund  
                  *Neg      say-1s            their names       here*  
                  ‘I do not say their names here.’

Despite the obvious differences between these forms, there is no suppletion here. Instead, rules of stress shift, syncope, provection, reduplication and lenition all interact to muddy the forms. Interestingly, the domain of application of these phonological rules provides evidence for CPH’s analysis. The entire verbal complex forms a single phonological unit that cannot be broken apart by adverbs and other intrusive material. This grouping, CPH call the “clitic group”—(κ). There is also a smaller phonological unit, the word (ω) which is the domain of stress and syncope. Consistently, conjunct particles (C) and enclitic pronouns stand outside the phonological word (19a). Preverbal particles (P) on the other hand vary in their position, depending upon what other material is in the clitic group (19b).

19.    a)        [κ C [ω P (P) (P) (P) V]]  
           b)        [κ P [ω P (P) (P) V]]

For concreteness let us consider the example of stress. Stress in Old Irish is always on the leftmost syllable in the word. This is true of absolute verbs, nouns, and adjectives. When the verb is complex, however, either with a conjunct particle or with a preverb, the stress falls on the second non-enclitic morphological unit:

20.    a)        C • P (P) (P) (P) V  
           b)        C • V  
           c)        P • P (P) (P) V  
           d)        P • V

There thus appears to be a special “pre-tonic” slot in initial position for a preverb or conjunct particle, which does not participate in the metrical structure of the rest of the verbal complex. CPH indicate the division between the pre-tonic position and the rest of the

complex with the use of the symbol <•> (as in Thurneysen 1980). Usually, the enclitic and any syllabic material it brings with it will be part of the pre-tonic. We can thus describe the distribution of the elements as follows:

21. i. Conjunct particles are always pretonic
- ii. If there is no conjunct particle, then the first preverb is pretonic

If we add a conjunct particle to a verb with preverbs, then the previously pretonic preverb joins the rest of the verbal complex and participates in its metrical structure, causing stress pattern to change as seen in 22b).

22. a. *as•biur*            “say-1s”            /as.biur /
- b. *•epur*            “say-1s”            /e.bur/;

The underlined syllable is the one that receives the stress. In 22) the preverb *as* appears in pretonic position and does not participate in the metrical structure of the verb (stress falls on *biur*). When the conjunct particle is added, the preverb behaves as if it is part of the second element in the complex, and takes main stress. The other phonological alternations (/a/~e/ and /sb/~p/) follow from this shift in metrical structure. See McCone (1987) for more details.

As the conjunct particles always fall in the pretonic position, CPH conclude that the pretonic position is associated with the complementizer head. Since one preverb is required to be pretonic when there is no conjunct complementizer, it follows that a preverb can satisfy the filled C° requirement. When there is no overt complementizer, only the preverb, not the entire inflected verb, raises to C° to satisfy the Filled-C requirement. The two different phonological domains formed by the complementizer head and the verbal head and the alternations in the shape of the preverbs strongly suggest that Old Irish had a weak V2 requirement.

#### 2.1.4.1.4 Object Enclitics

The final piece of evidence which CPH present in favor of their approach comes from the position of object enclitics. Old Irish has Wackernaglian second position enclitics (E) which include object pronouns, relative pronouns, and conjunctions. The enclitic pronouns are always found after the first morphological element in the verbal complex 23)

The following examples are taken from Strachan (1984):

23. a) Ní-m• accai (Ní + m + ad + cí-3sng)  
*Neg -me see-3s* C E P V-S  
 'she does not see me'
- b) aton•cí (ad + (do)n + cí -3sng)  
*P-us see -3s* P E V-S  
 'she sees us'
- c) bertaigh-i<sup>11</sup> (bertaig -th +i)  
*shake-3s.abs-him* V- S E  
 'he shakes him'

The distribution of enclitics is somewhat puzzling from a syntactic perspective if no filled C° requirement is assumed; sometimes they precede the verb (when there is a preverb or conjunct particle); other times they follow the verb (when the verb is absolute). Similarly, there is no easy phonological characterization of their placement. Sometimes they precede the first phonological word, i.e. when there is a preverb or conjunct particle, as outlined above. When the verb is absolute, there is no pretonic slot in the phonological sense - the first syllable of the verb receives main stress, as usual. In these cases, the enclitic follows the first phonological word. That is, if there is a pretonic element, the enclitic precedes the first phonological word, and if not, it follows it. Any phonological account would have to include a two-part rule to this effect; the syntactic account argued for here requires no such disjunctive rule. The distribution of enclitics is transparent when we

<sup>11</sup>This form is later replaced by *no-s•mbertaigedar*. However, the absolutive form continues to be used when there is no object pronoun. CPH are concerned mainly with the period when object clitics adjoined after the main verb.

assume, following CPH, that Old Irish had a filled  $C^\circ$  requirement. Once we make this claim, the distribution of enclitic pronouns is straightforward:

24. Enclitics (E) adjoin to  $C^\circ$ .<sup>12,13</sup>

This is true whether the  $C^\circ$  is filled by a conjunct particle, a preverb or an absolute verb form. CPH thus account for the complex and intricate behavior of verbs, preverbs, particles and clitics in the Old Irish verbal complex. They argue that Old Irish makes use of raising to  $C^\circ$  due to a filled  $C^\circ$  requirement. The fact that the pretonic and the rest of the complex behave metrically like two words rather than one follows from the fact that the two elements are in different structural positions in the sentence, forming a “clitic group” rather than a single phonological word. The distribution of absolute inflection is now definable in a systematic way: when the verb has raised to  $C^\circ$  it takes different morphology. Finally, the position of enclitics is now uniformly accounted for. They always attach to  $C^\circ$ , whether this be a preverb, conjunct particle, or the verb itself.

#### 2.1.4.1.5 \*Subjects in Spec-IP

Now, back to the issue of subjects in Spec-IP. Given that Old Irish enclitics attach to  $C^\circ$ , we can see that a CP- recursion analysis of VSO order is not available. First, these enclitics appear *within* the first prosodic unit; thus, a typical analysis of Wackernaglian

---

<sup>12</sup>An equally empirically adequate account, consistent with the analysis of the filled  $C^\circ$  requirement proposed here, is found in Duffield (1994). He proposes that there is an extra position between the highest Inflectional position and the  $C^\circ$ . This is the “Wackernaglian” head. The pronominal clitics could occupy this position in Old Irish and still be consistent with the present analysis. Note that such an approach is (at least) equally incompatible with the CP-recursion approach to the derivation of C-VSO order. The Wackernaglian head, a complement to C, presumably would occur below the recursive CP, again predicting the unattested C-V-E-S-O order. A morphological account of these phenomena could also be possible, according to which clitics could attach to the left of the first morpheme, no matter what it is, at a level of morphological structure; see Schütze (1994) for extensive discussion of such an approach for Serbo-Croatian clitics. As the syntactic account presented here is extremely straightforward, however, I will invoke Okham’s razor and assume it is to be preferred.

<sup>13</sup> Old English clitics have been analyzed as marking the left edge of IP in a similar manner, see, e.g., Pintzuk (1991). Similarly, the principle in 24) could equally be seen as the left adjunction of enclitics to IP.

cliticization under which these enclitics attach after the first prosodic unit is *prima facie* untenable. The phonological bracketing is as in 29) above, repeated below:

25.  $[\kappa C (E)[\omega P (P) (P) (P) V]]$

Note that an account of enclisis according to which the enclitic attaches either to the first phonological word or to the first prosodic unit (the clitic group  $\kappa$ ) would predict that the enclitic would suffix itself to the V, rather than appearing medially<sup>14</sup>. The only consistent characterization of the placement of these enclitics is as stated above: enclitics adjoin to  $C^\circ$ .

On a CP-recursion analysis, the verb would raise to an embedded  $C^\circ$  head, by assumption identical to the matrix  $C^\circ$ . Given that enclitics adjoin to  $C^\circ$ , we would expect the enclitics to be able to attach to either the initial  $C^\circ$  element, or the embedded  $C^\circ$  occupied by the verb, producing an optional C-V-E order, like the unattested and presumably ungrammatical form in 26) below.

26. a) \*Ní• accai -m (Ní + ad + cí-3sng+ m)  
*Neg see-3s-me C P V-S E*  
 'she does not see me'

Such attachment is not possible. Therefore, the verb is not raising to an embedded  $C^\circ$  head, but to a position on the left edge of IP, in I.

Given that that is the case, we can see that subjects in Old Irish are not generated in Spec-IP, as they do not appear between the verbal and complementizer heads.

---

<sup>14</sup>It is possible an account could be proposed according to which the enclitic looked for the first phonological word and affixed itself to the *left* (rather than the right). Such an approach would run into problems in the instances where no pre-tonic units appear in the verbal complex, as in these cases the enclitic adjoins to the *right* of the first phonological work. Also, such an approach seems unnecessarily unusual; accounts of Wackernaglian cliticization tend to use suffixation to the first prosodic unit (see, e.g. Schütze (1994) and references cited therein). Arguing for prefixation in the middle of the first prosodic unit seems particularly abstruse given that a clear syntactic constituent is available to the analysis at exactly the right place.



### 2.1.5 Conclusion

It thus seems there is much to be gained from the assumption that SpecIP is not the position in which subjects are projected. Much of the above work, however, was done prior to the advent of “expanded Infl”, according to which “IP” is an abbreviation for two or more functional XPs above VP. The above argumentation strongly indicates that the *highest* XP in the Infl complex cannot be the position of subject projection. Given the many empirical and conceptual grounds for assuming a richer structure for Infl, though, the question of where the base-generation of subjects is in fact accomplished cannot be considered to be settled by the above discussion.<sup>15</sup> Most of the work cited above assumes that the only other possible subject position available is Spec-VP. Indeed, base-generation in Spec-VP is seen as a desirable analysis, as it resolves the dichotomy in question 2) above: the problem of non-locally assigning a theta-role to the subject. Spec-VP is within the maximal projection of V, hence theta-assignment is local. We must, however, consider the possibility that while the highest XP in Infl does not project subjects, some other functional projection above VP in Infl might.

### 2.2 Subjects in Expanded Infl?

Given the compelling convergence of syntactic evidence for Spec-IP as a derived position for subjects, I conclude (with most of the field) that subjects are in fact generated somewhere below Spec-IP. In languages where they appear overtly in that position, they have moved there during the course of the derivation.

---

<sup>15</sup> Further, the issue of whether subjects in VSO languages are appearing in their base-generated position or in some intermediate derived position is also not resolved here. For extensive discussion of this issue, see Carnie (1995).

As noted above, the question of where subjects are in fact base-generated is still not settled, even given the discussion of Spec-IP in the previous chapter. The above is a negative statement—what’s established is that subjects are not base-generated in Spec-IP. Without a theory of clausal syntax that involves an “articulated” Infl (introduced in Pollock (1989)), there is only one possibility for base-generation of subjects other than Spec-IP, that is, internal to the VP. Most of the work summarized in section 2.1 above assumed Spec-VP to be the locus of base-generation, and to a certain extent, this has become the standard assumption of much recent literature. There are certain conceptual and empirical problems with such an approach, however, and several versions of the ISH have resulted from attempts to resolve some of the issues of selection, projection and licensing that result from altering the system built around the standard clause structure with subjects in Spec-IP. Below, I examine some of these proposals and suggest that they seem to converge on a certain configuration for the VP, seen in 27) below:

27.

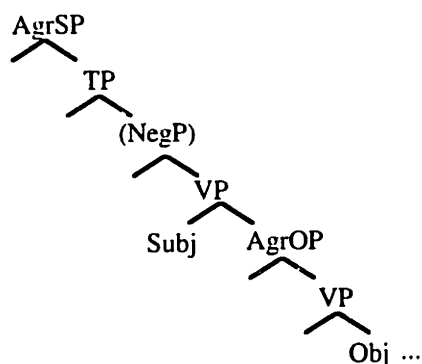

First, however, we should examine the possibility that subjects, although not generated at the left edge (that is, the highest specifier position) of an articulated Infl, are in fact generated in some lower projection contained within Infl and yet are external to the VP proper. There are many proposals for configurations of the functional complex above VP; for this argument, I will take that proposed in Chomsky (1991) and adopted in much later work as standard. A sample tree is seen in 28) below:

28.

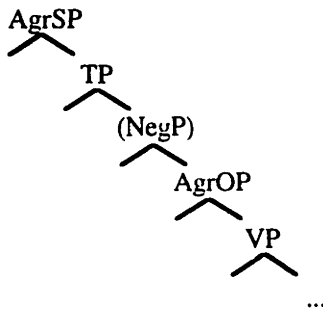

In such a representation, the arguments presented in section 2.1 above dealing with the position of subjects are mostly relevant to Spec-AgrS. What was taken for VP coordination in section 2.1 above could just as easily be TP or AgrOP coordination; similarly, the argument from VSO order in 2.5 holds only for the specifier of AgrSP if the verb raises to the left edge of Infl (i.e. to AgrS). We conclude, then, that the previous discussion essentially demonstrates that subjects cannot be base-generated in Spec-AgrSP (or whatever the highest projection in Exploded Infl is in any given proposal).

What about specifiers of any of the lower projections of the inflectional complex? Spec-TP, for instance, seems a likely candidate. Many proposals (e.g. Chomsky 1994) assume that it is the Tense head that is ultimately responsible for nominative case assignment, and it has been argued that subjects can appear in Spec-TP at Spell-Out (Jonas and Bobaljik (1993), Bobaljik and Carnie (1992), among others). Are there reasons to think that Spec-TP cannot be the locus of subject projection? Some of the arguments put forward in the preceding section are such reasons; they argue against base-generating subjects in Spec-TP as well as against base-generating them in Spec-IP/AgrSP

### 2.2.1 *Tense and modals as raising categories*

The Koopman and Sportiche (1991) argument that I behaves like a raising category can be carried over to cover any projection in exploded Infl. Material in I, including Tense

and modals (which must be generated in T or lower), does not impose any selectional restrictions on its subjects, in the manner of a raising verb like *seems*. It is possible for the subject of an idiom to be specified independently of the content of T. Any tense or modal can appear within the idiom: “The shit was/will/might/should/may... hit the fan.” Similarly, “weather *it*” can appear in a clause in any tense—“It rained/will rain/may rain.” The crucial selectional restriction on the content of the subject seems to be being imposed by the material in the VP (“hit the fan”/ “rain”) rather than by Tense. In this respect, then, the content of T is behaving like a raising category, and the parallel treatment with raising verbs is indicated.

The argument of Kitagawa (1986) and Koopman and Sportiche (1991) that subjects show embedded scope with respect to modal/tense elements (section 2.2) could also be taken to indicate that Spec-TP cannot be the base position of subjects, as it is not c-commanded by the position of base-generation of the modal. This is a somewhat weaker point, however, as Tense will subsequently raise to AgrS and perhaps higher in the clause, into a position where it could c-command the trace of the subject in Spec-TP, and conceivably could be interpreted in that position.

### 2.2.2 *Subject trace in VP: Huang (1993)*

A stronger case can be made that the argument from Huang (1993) demonstrates that Spec-TP cannot be the site of base-generation of subjects. The fronted constituent in 29) (ex. 6b) of section 2.1.3) below is some XP (here VP, following Huang) that excludes Tense, as is evidenced by the modal at the extraction site. The point is even more evidently underlined given that negation remains in situ at the extraction site, below the modal, and hence the trace of the fronted constituent is lower than NegP, which in turn is clearly lower than TP in the tree above. (Recall that Huang takes the forced coreference of *each other*

with the subject of the embedded clause to indicate the presence of a trace of the subject in the fronted constituent.)

29.

[<sub>VP</sub> Talk to friends of each other<sub>\*i/j</sub>] they said t we<sub>j</sub> should not t

### 2.2.3 Complement to causative “have”

Finally, there are instances where a clause that lacks Tense (finite or otherwise) but does contain a subject is embedded below some matrix verb (which presumably assigns the embedded subject Case). The subject seems to be surfacing in a position that is clearly not part of the inflectional complex, rather than indicating that a trace or other element that is interpreted as coreferential with the subject exists below the Infl complex. One might object that alternative theories are available in which the above arguments are taken merely to indicate something about the nature of theta-relations and predication, notably developed in Williams (1993). The examples below, however, indicate that the subject can actually surface in a position below TP/IP, and hence provide strong support for the movement account of the ISH facts.

In English, this type of clause is found as a complement to causative *have*, as in example 30) below:

30. Rosebud had Opus and Bill dress in Spandex.

Ritter and Rosen (1993) (R&R henceforth) provide extensive evidence that the complement of causative *have* contains no Infl material (or at least very little). Among other things, they claim the complement to *have* cannot contain Tense or Negation, nor can it contain non-thematic subjects. In each case, they contrast the complement with the complement of *make*, which just as clearly does contain inflectional material, as it allows

Tense and Negation to appear, as well as non-thematic subjects. Below, I sketch some of their arguments. For extensive discussion, I refer the interested reader to the original work.

Inflectional material like auxiliary *be* is prohibited from appearing in the complement of causative *have*, but is allowed with *make*:

31. a) ?? Rosebud had Opus *be* sniffing dandelions for the Picayune photo shoot.  
b) Rosebud made Opus *be* sniffing dandelions for the Picayune photo shoot.  
c) Rosebud had Opus sniffing dandelions for the Picayune photo shoot.  
d) \*Rosebud made Opus sniffing dandelions for the Picayune photo shoot.

Neither can clausal negation appear in the complement of causative *have*, as seen in 32) below; it is, however, fully acceptable with the complement of *make*.

32. a) ?Rosebud had Opus not dress in Spandex.<sup>16</sup>  
b) Rosebud made Opus not dress in Spandex.

Expletive subjects are illegitimate as the subject of the complement of *have* while being perfectly well formed in the complement of *make*. R&R attribute this to the fact that expletives may only appear in a non-thematic position (Chomsky 1981, 1986, Rothstein 1983). Accepting expletives as evidence of the presence of inflectional material, however, the examples in 33) below indicate that the complement to causative *have* is inflectionally impoverished compared to the complement of *make*.

33. a) \*Rosebud had it seem that Opus dressed in Spandex<sup>17</sup>.  
b) Rosebud made it seem that Opus dressed in Spandex.

---

<sup>16</sup>R&R suggest that the reason this sentence is not completely bad is the possibility of an adverbial interpretation for *not* here. The clausal interpretation is fully ungrammatical; however, when the *not* is heavily stressed ("Rosebud had Opus NOT dress in Spandex") the sentence becomes completely grammatical. Stressed *not* is adverbial, and can co-occur with clausal negation, as demonstrated in the following example (note the double negation in the second conjunct):

i) When Milo spent the day cleaning his office, he wasn't working, but he wasn't NOT working either.

See R&R pp. 538-9 for further discussion.

Marantz (p.c.) notes that this property could be the result of the semantics of causative *have*; he suggests that it is not clear what clausal negation underneath causative *have* would mean, given that *have* has an interpretation like "bring the situation about". This does not affect the argument about constituency above; presumably the complement to *have* will be a constituent that is semantically compatible with the meaning of *have*. Whatever this constituent is, it does not include TP or NegP, but does include agentive subjects.

<sup>17</sup>Marantz (p.c.) points out that "Opus had it seem *as if* Rosebud dressed in Spandex" is better than 33a) above; this might indicate that the "seem as if" construction differs from those discussed above, which is not necessarily surprising; the difference, for this argument to go through, would have to reside in the nature of "it" in the two instances..

(It is worth noting that aspectual markers *can* appear in the complement of *have*: progressive *ing* and perfective/passive *-en* are well-formed in the complement, as seen for the former in 31c) above and for the latter in 34 below; we will return to this significant fact in Chapter 4 below).

34. Rosebud had dandelions picked for the table setting.

Here we note that the subject of the passive is not appearing in its base-position in 34) above, but in the position we are claiming contains agentive subjects as well. Either, then, this position can be both a thematic and non-thematic position, or agentive arguments appearing in this position have moved there from a lower projection as well (by the same rationale we applied to Spec-IP earlier). Interestingly, it appears as if we want to claim the former is true in this instance. Passive and active complements *cannot* be conjoined under the subject of the complement of *have* (35), unlike subjects of matrix clauses :

35. \*Opus had Rosebud dressed in Spandex and leave/leave and dressed in Spandex.

Coordination of active and passive complements to *have* with different subjects is good (36):

36. Opus had Rosebud leave and Susie dressed in Spandex.

If the agent in this instance is base-generated in this position, while the object moves there, the ungrammaticality of 36) can be explained as exhibiting the Coordinate Structure Constraint effect in exactly the way that VP-coordination in section 2.1.1 did not<sup>18</sup>. This could then be construed as constituting evidence that agentive subjects are base-generated in the specifier of some projection that includes aspectual information, but not Tense.

---

<sup>18</sup>This account of the ungrammaticality of 35) could require some re-thinking, given that conjoining a passive VP and a small clause is grammatical, while conjoining an active and a small clause is poor:

- i) Milo had Rosebud on the stretcher and covered in bandages.
- ii) Milo had Rosebud breathe deeply and covered in bandages.

Similarly, a non-passive yet stative verb form *can* conjoin with a passive to give a grammatical result:

- iii) Milo had Opus dressed in a tie and running for President (in the wink of any eye).

On the account above, this would entail that the small clause *Rosebud on the stretcher* or the progressive *running for President* involves some movement similar to the movement in the passive, ensuring that the CSC is not violated; this perhaps seems unlikely. The stativity of small clauses and participles might be the key to a non-movement account; a fuller exploration is left to later research.

Similar facts obtain for the embedded predicates in Japanese causatives; they are morphologically tenseless, yet the embedded subject is projected quite satisfactorily, as can be seen in 37) below:

37.   Yakko-ga      Wakko-ni      pizza-o      tabe(\*ta)-sase-ta  
       *Yakko-N*      *Wakko-D*      *pizza-A*      *eat-( \*Pst)-cause-Pst*  
       “Yakko made Wakko eat pizza”

We can conclude with reasonable certainty, then, that subjects cannot be base-generated in the specifier of TP.

#### 2.2.4 *Against generation in AgrOP*

The set of assumptions surrounding AgrOP in a Minimalist-style analysis make it an unlikely candidate for base-generating subjects. AgrOP is the position responsible for the assignment of case to the object and the checking of any objective agreement features that appear in the verbal complex. This checking happens in a spec-head configuration: the object is assumed to raise to the specifier of AgrOP and check features against the verb, which has head-moved to AgrO. AgrO is a purely functional category, then (indeed, Chomsky (1993) even suggests that Agr categories delete at LF, as they are not semantically relevant). If the subject were base-generated in Spec-AgrO, the A-chain formed by movement of the subject to positions higher in the clause would have its tail in Spec-AgrO. In order for the object to check its features in Spec-AgrO, that position would have to contain two separately theta-marked chains. The tail of the subject’s chain would have to be present at LF if the account we adopt of embedded scope with respect to elements in Tense is correct, and the object would have to be there to establish that its case is appropriately licensed. I thus dismiss the possibility that AgrO is a possible candidate for the base-generation of subjects.<sup>19</sup>

<sup>19</sup>Chomsky (1995) posits adjunction to a light verbal projection vP to which objects adjoin for case-checking, where subjects are also base-generated; this is possibly tantamount to generating subjects in Spec-AgrOP. I will not discuss the ramifications of that proposal in detail for the analyses proposed here, however, on any account where the object must cross the surface position of the verb to check structural



It is worth noting, however, that on a set of assumptions about case-assignment like those sketched in the preceding paragraph, AgrO must be present in the inflectionally impoverished embedded clauses examined in R&R and discussed above (ex. 30)-36)) to check the case of the embedded object. There are two possibilities for the placement of the subject with respect to this clause. It could be generated in the VP below AgrO. The object would then covertly move over the subject trace in VP at LF for case-checking purposes. This would entail that the complement to causative *have* above is in fact an AgrOP.

The second possibility is that there is (at least one) projection between NegP and AgrOP in 28) above in which the subject is generated. This would entail a clause structure like that in 38) (first introduced in 27) above). (“Subj” below indicates the position the subjects of the embedded clauses above would appear in; I label this projection VP for the moment, following Koizumi (1993); I will discuss its character and rename it in Chapter 3):

38.

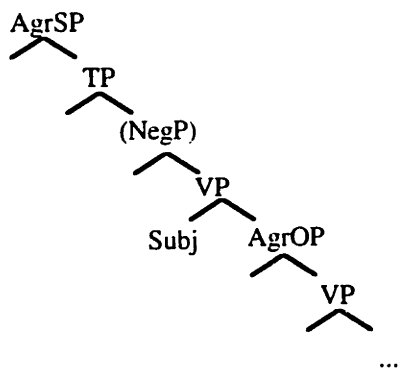

The former structure, involving movement of the object across the trace of a subject for case-checking in Spec-AgrOP, is the approach assumed in the Minimalist approach sketched in Chomsky (1993) and adopted in much subsequent work. Following Bobaljik (1995), I will term these types of crossing-path analyses “Leapfrogging” structures. The

---

case, the account of the Adjacency effect in Chapter 3 cannot be adopted. See also the discussion of Burzio’s generalization in Chapter 6.

latter (in 39), involving no crossing of the object and subject A-chains<sup>20</sup>, is a “Stacked” structure.

### 2.2.5 Conclusion

In Chapter 3, we will see that there are empirical and conceptual arguments *against* assuming Spec-VP is the position in which subjects are generated, where Spec-VP is defined as the specifier of the canonical verbal projection that selects a direct object complement. A seeming paradox then arises: one of the strongest theoretical reasons proposed in the early arguments for assuming the ISH was that it allowed a consistent approach to the projection principle: theta-roles are assigned locally. Hence, Spec-IP cannot be the locus of subject theta-role assignment. But as we will see in Chapter 3, Spec-VP cannot be the locus of subject base-generation either—subjects must be base-generated outside Spec-VP. Presumably, then, the problem with the Projection Principle still remains—how can the subject receive its theta-role from the verb, when it is not in a local relation with it? In Chapter 4, we will see that the problem is not with the Projection Principle *per se*, but with the idea that the verb assigns a theta-role to its external argument.

---

<sup>20</sup>For case-checking, anyway—see the discussion of the necessity of crossing-paths movement in Chapter 6 below.

### 3 *VPs, I-syntax and external arguments*

---

In this chapter, we move on to consider arguments about the nature and location of the subject-generating position. The account we adopt by the end of the section 3.1 is that subjects<sup>1</sup> are generated in some projection distinct from that in which objects are projected; not only that, this position is *above* the position (for us, an AgrP) in which objects check Case (cf. example 27) in Chapter 2). The initial motivation for this approach is provided by a (modified) account of Case Adjacency proposed in Koizumi (1993). Under the clausal configuration described, an attractively strict characterization of adverb placement facts is possible. Further motivation is provided by the account of compositionality within the VP suggested by Kratzer (1993), according to which the semantic properties of subjects result from their projection by a head separate from that which projects objects. We then briefly revisit the adverbial facts, examining the different readings obtained when an adverb

---

<sup>1</sup>A cautionary note is in order here: in this chapter we will be discussing *external arguments* and their locus of base-generation; when discussing the projection where “subjects” are generated I intend the reader to understand that this is where external arguments are generated. Subjects of passives are not generated here, nor, arguably, are the subjects of psych predicates or copular clauses. Experiencer subjects of psych predicates are dealt with in greater detail in chapters 4 and 5.

adjoins to the subject projection and the object projection, suggesting the different types of head involved. This leads us to a detailed discussion of the constituency of the VP in section 3.2.

Having examined some of the reasons for assuming that the projection in which subjects are generated is distinct from the projection where objects are projected—that is, that the ISH conception of the VP does not exist—we move on to investigate the nature of the projections that make up verbs and argue that the conservative version of the distinction between lexical syntax and clausal syntax is a spurious one. Assuming a Late Insertion approach to lexical insertion, evidence from Japanese causatives suggests that what Hale and Keyser (1993) refer to as *l-syntax* can be identified structurally, as it is delimited by iterations of a purely verbal category—that is, by the external-argument-projecting head argued for earlier. We then move on to consider cross-linguistic evidence for this analysis which links the possibility of double-object constructions with the presence of a verbal expression of possession in a given language. This correlation constitutes strong evidence for the reality of the proposed syntactic breakdown of verbs into “basic” meaning components like “cause”, “have”, “be”, etc.

### *3.1 In support of stacked structures: case-checking, short V-movement and compositionality*

The proposed structure for the VP can be seen again in 1a) below. Recall that the crucial feature of this proposal is that the subject is projected in the specifier of a head distinct from the head which projects objects, unlike the standard tree in 1b). Below, I will go over some syntactic arguments for this type of structure, and suggest that it solves a number of conceptual problems with the ISH.

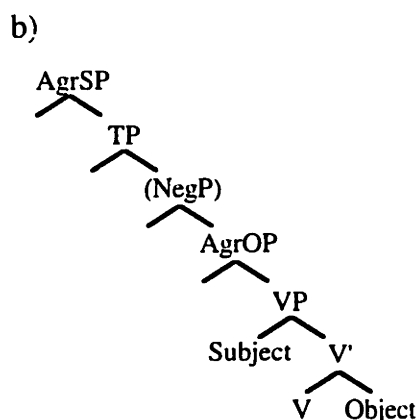
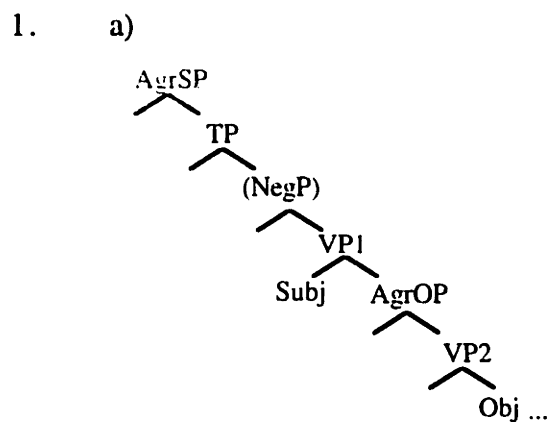

The difference between the structure in 1a) above and the Chomsky (1994) structure in 1b) which I will initially focus on is the position of AgrOP with respect to the projection in which subjects appear in—that is, with respect to the highest VP. In Chapter 2, example 28) above, the subject is base-generated below AgrOP, while in 1a) it is base-generated above AgrOP. I will assume as a minimal hypothesis that subjects should be generated only as low in the tree as is necessary to account for the ISH facts outlined above. A possible account of the facts to be discussed below might be that subjects are generated in the lower VP and undergo leapfrogging movement to the higher VP and from there to the higher positions in the Infl complex<sup>2</sup>. Such an analysis would make similar empirical predictions to the account actually assumed here (that is, that subjects are base-generated in some projection between AgrOP and NegP) but would posit more movement for the subject than is necessary to account for the facts; considerations of economy, then,

<sup>2</sup>Indeed, this is a possible account for non-agentive external arguments (experiencer subjects, for example), discussed further in chapter 5 below.

dictate that it be discarded in favor of the more movement-parsimonious account. More germanely, as discussed in the rest of section 3.1 below, there are compelling conceptual reasons for assuming that the head that projects/selects (agentive) subjects and the head that projects/selects objects are, in fact, distinct. The syntactic facts below which demonstrate that the verb moves overtly in English to some position below T but above its base position also demonstrate that the external argument is generated above AgrOP in English.

### 3.1.1 Overt object movement and ECM

I will begin with a *prima facie* problem for the combination of the ISH and the 1b) version of AgrP placement theory pointed out in Jonas (1992), Harley (1994) and Baltin (1995). Assuming that the infinitive marker *to* and the TP-adverbial *always* mark the position of the embedded clause's TP, we can see from 2) that the subject has moved out of its VP-internal position before Spell-Out to some position that is to the right of the matrix verb.

2. Charlie Brown wants Snoopy<sub>i</sub> always to t<sub>i</sub> sleep in his doghouse.

Note that in some languages, where the edge of the complement clause is marked with a complementizer, ECM unambiguously indicates movement to the higher clause, past the complementizer. An example from Malagasy is seen in 3), taken from Travis (1991):

3. a) Nanantena iRakoto [fa nianatra tsara ny ankizy]  
*pst-hope-AT Rakoto Comp pst-study good the children*  
 "Rakoto believed that the children studied well."
- b) Nanantena an' ny ankizy [ho nianatra tsara] iRakoto  
*pst-hope-AT Acc the children Comp pst-study good Rakoto*  
 "Rakoto hoped that the children studied well"

The object in the ECM case in 3b) appears unambiguously in the matrix clause, to the left of the complementizer. Travis argues that the landing site for objective case-assignment is within the matrix VP, essentially, a split-VP analysis of such data. We will return to her proposal in section 3.2 below.

Similar facts appear in Icelandic, as noted in Jonas (1993). Icelandic indicates optional movement of the object NP to a higher position, past a matrix adverbial, as seen in 4) below:

4. Ég taldi stúdentana í barnaskap mínum [hafa lesið bækurnar]  
*I believed the students-A in my foolishness have read the books*  
 “In my foolishness, I believed the students had read the books”

Now, return to the English case in 2) above, where the subject obviously has moved away from the base-generated VP-internal position, but not necessarily obviously into a position in the matrix clause. Consider the possible motivation for this movement. Infinitive Tense, by hypothesis, has no N-feature that needs to be checked by PF—indeed, such checking is ill-formed. (\*Daffy to dance is fun.) The example in 2) would surface as 5), with the subject in its base position:

5. \*Charlie Brown wants [<sub>IP</sub> always to [<sub>VP</sub> Snoopy sleep in his doghouse]

The movement that is postulated for the ECM subject in a theory of clause architecture like that in 1b) is movement to the *matrix* AgrOP at LF—that is, to the left of the surface position of the English verb. This is the LF movement postulated for all English objects in Chomsky (1994).<sup>3</sup> Transparently, *Snoopy* occurs to the right of the matrix verb in 5). It hence cannot have moved to the matrix AgrO if the matrix AgrO is above the surface position of the English verb. What, then, has triggered the movement of *Snoopy* out of its base position? A simple answer is provided by the structure in 1a): case-checking motivates this movement, not at LF, but prior to Spell-Out. The matrix AgrO is embedded *below* the top VP projection, where the verb surfaces at Spell-Out, giving V-O order in spite of the overt case-checking. No additional mechanism for motivating movement is therefore necessary for such cases<sup>4</sup>.

<sup>3</sup>ECM subjects behave as objects of the matrix clause in that they c-command anaphors in certain types of matrix adjunct clauses (see, e.g. Lasnik and Saito (1991)), in addition to the other facts cited above.

<sup>4</sup>The account here is a return to the “Raising to Object” approach, rather than an ECM approach; see further discussion of this type of case marking in Chapter 5 below.

Koizumi (1993) points out that facts originally noted in Postal (1974) seem to indicate that movement to the matrix clause has happened prior to Spell-Out. Matrix adverbials which do not occur in embedded clauses (6a)) appear to the right of the embedded subject in ECM constructions (6b)). Hence, the ECM subject must also be in the matrix clause<sup>5</sup>:

6. a) Milo proved [that (\*conclusively) Senator Bedfellow (\*conclusively) was a liar]  
b) Milo proved Senator Bedfellow conclusively [to be a liar]

Another interesting piece of evidence for overt movement to AgrOP of the ECM subject noted by Koizumi is the fact that the particles of verb+particle constructions can appear to the right of the ECM subject. Again, particles cannot appear in embedded finite clauses (7a) below), nor can they appear to the right of non-NP arguments of V (7b)) in simplex clauses. 7c) demonstrates that they can, however, appear to the right of ECM subjects.

7. a) Milo made \*(out) that (\*out) Senator Bedfellow (\*out) was a liar.  
b) Linus teamed (\*with Lucy) up.  
c) Milo made Senator Bedfellow out to be a liar.

The fact that particles and matrix adverbials can appear to the right of the ECM subject indicates that the subject is in the position of an NP argument of the matrix verb. It is evidently the case that it is not theta-marked by the matrix verb; the only way in which an ECM subject behaves as a matrix object is in case-checking accusative in the matrix clause. It must be this property which motivates movement up to the matrix. There is no way for such movement to a matrix clause to take place overtly on a 1b)-type structure, as it would result in an incorrect O-V order. On the other hand, if we adopt a split structure such as that suggested by Koizumi in 1) we can allow overt movement for ECM case-checking in English and still get the correct V-O order.

---

<sup>5</sup>Marantz, p.c. points out that matrix adverbs seem to be less felicitous below expletive subjects in these constructions (see i) and ii) below), calling into question the selectional relationship between the matrix verb and the ECM NP; for me, however, the difference in grammaticality is not clear.

- i) ?Milo proved it conclusively to be obvious that Opus was wrong.  
ii) ?Milo proved there conclusively to be basselopes on the roof.



### 3.1.2 *Overt object movement in simplex clauses: the adjacency condition*

Presumably, then, if NP movement for accusative case-checking takes place overtly in ECM structures, the null hypothesis is that it also takes place overtly for objects in simple transitive clauses, as the two cases can then be unified under a characterization of all English AgrOPs as bearing a strong N-feature, requiring checking prior to Spell-Out. This would necessarily be accompanied by verb movement to a projection above AgrOP, as discussed earlier with respect to ECM, to derive the correct V-O order. Is there evidence for such movement?

Pesetsky (1989) argues extensively that the main verb undergoes some overt movement in English from a lower projection to a higher projection while still failing to move beyond the locus of sentential negation (and thus still maintaining the account for the famous French-English contrast with respect to V-movement to T and beyond noted in Pollock (1989)). This verb movement is followed by movement of the direct object for case purposes, as discussed for ECM above. Pesetsky argues that this overt movement derives an account of (some of) the facts that lead Stowell (1981) to propose the Adjacency Condition on case assignment. Johnson (1991) extends this argument to account for an additional set of adjacency facts. Koizumi (1994) points out some shortcomings of the above accounts and argues that the adoption of the clause structure in 1a) provides a more elegant characterization of the data. Below, I summarize the account he proposes for the adjacency effect. Readers are referred to the original work for details.

The basic fact that led to the proposal of the Adjacency Condition is seen in 8a) below: an adverb<sup>6</sup> cannot appear between a verb and its accusative-case-marked argument. 8b) shows that this does not hold for prepositionally case-marked arguments. If there is

---

<sup>6</sup>The class of adverbs we are dealing with here is exactly that which allows the formation of middles: "This book shelves easily", "This kind of cake bakes quickly."

both a prepositionally case-marked argument and an accusative case-marked argument, the adverb may not appear between the verb and the accusative argument, but it may appear between the accusative and the prepositionally marked argument, as seen in 8c):

8. a) \*Opus sniffed quickly the dandelions.
- b) Opus sniffed quickly at the dandelions.
- c) Opus gave the dandelions quickly to Rosebud.

The Adjacency Condition is a linear precedence condition: adverbs may not appear between an accusative NP and the element which case-marks it. The notion of linearity, however, is largely assumed to be unavailable to the syntax proper (although, e.g., Kayne (1994) argues otherwise), and presumably it is desirable to motivate a structural account of these facts. Initial syntactic accounts (Pollock (1989) and Chomsky (1991)) relied on the notion of sisterhood in these cases: the adverbs could not appear between the verb and its direct object because they were sisters. This approach is flawed in that it predicts no difference between 8a) and 8b): both the NP and the PP are sisters to the verb on their accounts and hence adverbs should not be able to intervene in either case.

Pesetsky (1989) accounts for the difference between 8a) and b) by invoking short verb movement in the latter but not the former case. The verb head-moves left over the adverb, which is adjoined to the left of the VP. (Pesetsky gives evidence from the scope of stacked adverbs that adjunction is to the left, rather than to the right with subsequent PP extraposition.) For Pesetsky, such movement is licit because the verb does not have to case-mark its PP sister in 8b). In 8a), on the other hand, verb movement cannot occur because the verb must case-mark its direct object NP, which is rendered impossible when the leftward movement occurs. The two relevant structures can be seen in 9) below:

9.

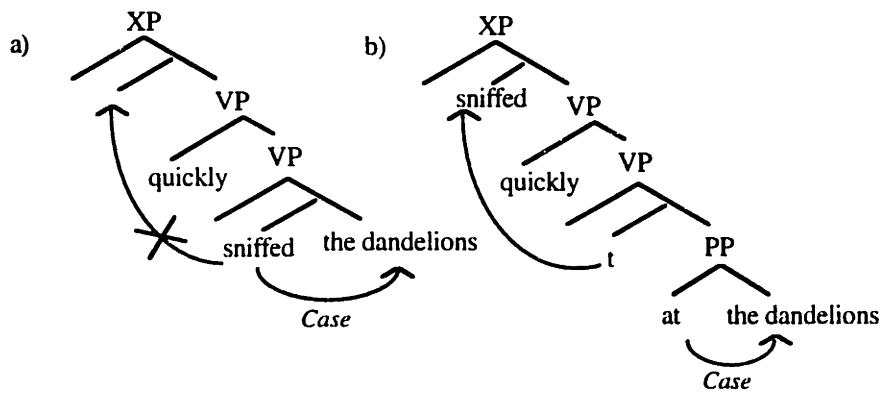

A problem for this account arises, obviously, in cases like 8c), when there is both a prepositional and an accusative argument. The accusative argument entails that the verb has remained in situ in order to case-mark its direct object, but the fact that the left-adjoined adverb can occur to the left of the preposition entails that the verb has moved out of the VP.

Johnson (1991) proposes that the solution to this problem is to assume that both the verb and the direct object move at S-structure<sup>7</sup>. The verb raises to the head of the phrase above VP. The object moves to Spec-VP, where it can be assigned case from the head of the phrase above VP, where the verb is located. The adverb is adjoined to the V' projection, rather than the VP. PPs need not undergo such movement, and hence V' adjoined adverbs appear between the PP and the verb (as in 8b)), and between the PP and the direct object (in 8c)). The relevant structure can be seen in 10) below.

<sup>7</sup>This solution is reiterated in Bowers (1993), seemingly independently.

10.

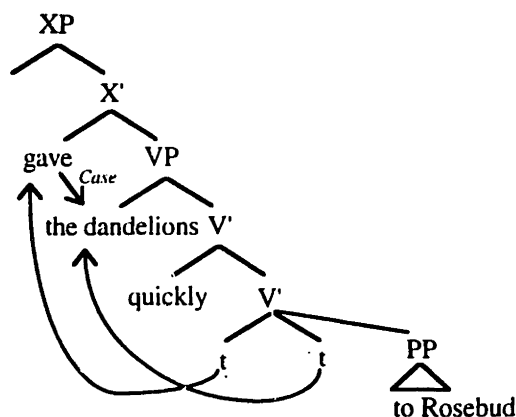

Note that Johnson's analysis requires that the specifier of the VP remain empty so that the object can move into it. We are getting closer to the configuration in 1) above. His analysis remains problematic, however, given his assumption that the PP is a sister to the V and its complement. Tripartite branching makes the wrong predictions in cases where there are two PPs, between which an adverb can occur, as in 11) below. Binding asymmetries between the PPs in 12a) indicate that the first c-commands the second; the two PPs behave as a constituent for coordination in 12b) and (as Pesetsky notes) the scopal relations between stacked adverbs indicate that no extraposition of the PPs has taken place.

11. Senator Bedfellow talked to her calmly about it.

12. a) Rosebud talked to Binkley about himself/\*to himself about Binkley.  
 b) Rosebud talked [to Binkley about himself] and [to Milo about Opus].

Essentially, the problems with Johnson's analysis are those which prompt Larson (1988) and Pesetsky (1994b) to posit binary-branching, multiply-embedded structures for this type of construction (cf. Barss and Lasnik (1986)). Note that, at the very least, an adequate account of the Adjacency Condition facts which adopts a strict structural characterization of adverb placement requires verbal movement to a higher projection. In a sense, then, we have already demonstrated something about the base position of subjects: there exists a projection between the base position of the verb and the lowest Infl<sup>8</sup> projection, to which the verb must move before PF. Given that we do not want to posit

<sup>8</sup>Where "Infl" here refers to TP and NegP.

unnecessary movement for the subject, this projection is a likely candidate for base-generation. The exact nature of objective case-checking, however, will be relevant in later chapters; in addition, it behooves me to provide some motivation for the later adoption of an AgrP-based account of case and agreement checking. I thus proceed with the summary of Koizumi's analysis.

Koizumi maintains that even an account which incorporates VP-shell type structures into a Johnson-style analysis is inadequate. Recall that adverbs must be characterized as adjoining to V' on such an analysis. Consider the ungrammatical double object sentence in 13a). Given the V'-adjunction approach, this sentence is predicted to be grammatical, with the partial structure in 13b):

13. a) \*Opus gave Lola Granola secretly the ring.  
 b)

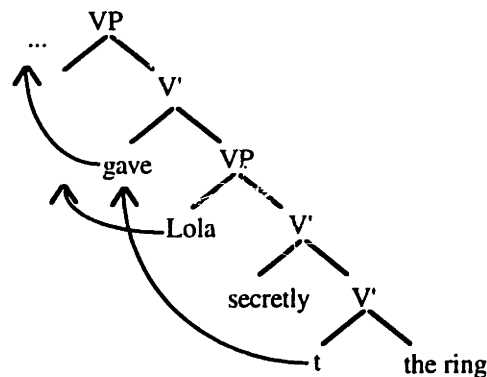

(I use V and VP here *a la* Larson; with respect to these facts, the difference between the Pesetsky (1994) PP-shell vs. the Larsonian VP-shell is not relevant, as *adverbial* adjunction to the bar-level phrases of shells is necessary here (e.g. to account for left-adjunction between the two PPs in 11) above) no matter what category the shells are. For further discussion of the identity of shells on this approach, see section 3.2 below.)

It seems, then, that an account of case-assignment by the verb under some government condition, forcing a bar-level condition on adverbial adjunction, cannot encompass all the necessary facts. Consider, then, an account using a specifier-head relation in an AgrP to check case, such as that outlined prior to the adjacency discussion

above. We have seen that the clausal architecture illustrated in 1b) is untenable on such an approach; we will now examine how a structure like Koizumi's 1a) fares with respect to the adverbial facts above.

On this account, adverbs are characterized as adjoining to a V head with semantic content which can license them (Zubizarreta (1982), Travis (1988)). AgrPs have no such content, hence adverbs cannot adjoin to them. The Adjacency Condition then follows if objects (as suggested above) move overtly in the syntax to check case in AgrOP, while the verb undergoes short movement to the XP immediately dominating the AgrOP. No adverb may adjoin to the AgrOP, hence no element may intervene between the object in Spec-AgrOP and the verb in X above it. In double object constructions, an AgrIOP is necessary, as the Goal object must check structural case. Movement to both AgrIOP (Koizumi's  $\Omega$ P) and the AgrOP is necessary in the overt syntax, hence, no adverb may intervene between the two arguments. The phrase structure of a clause with two NP arguments and a PP is shown in 14) below, including indications of the possible sites for adverbial adjunction:

14.

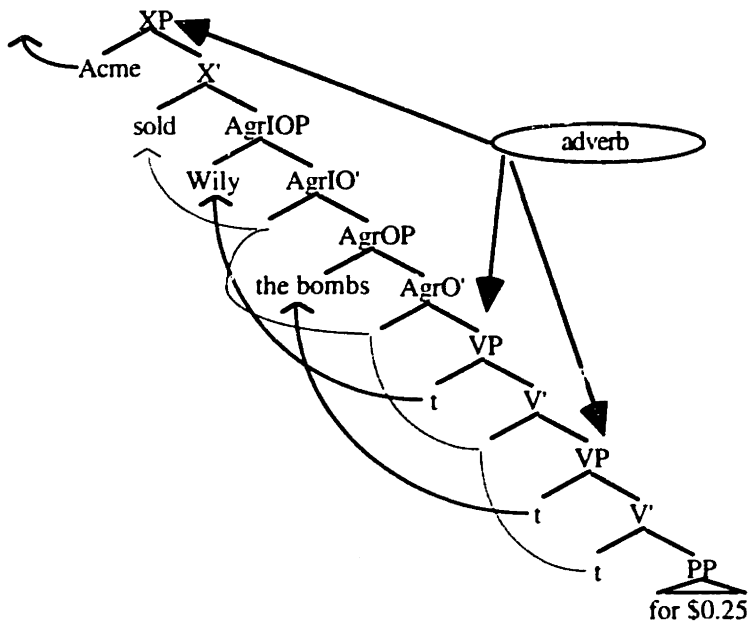

Koizumi (1993) claims that AgrIOP is in fact some kind of aspectual projection  $\Omega^9$  (present in all clauses) which, when checked, “delimits” the verb in the sense of Tenny (1994)<sup>10</sup>. He argues that particles in verb-particle constructions show up in this position (AgrIO), and optional movement of the object to Spec-AgrIOP allows the particles to appear to the right or left of the direct object. Pronouns obligatorily shift to Spec-AgrIOP (in a manner reminiscent of the mandatory overt shift of Swedish object pronouns), and hence force the order Verb-Pronoun-Prt (\*V-Prt-Pronoun, as in *\*he looked up it* ). I would rather suggest that the optional appearance of direct objects between the verb and the particle results from optional stranding of the particle clitic in an Agr head, as the verb moves upwards—that is, V-Obj-Prt order indicates that the particle has been stranded, while V-Prt-Obj order indicates that the particle has remained with the V head throughout and has moved up to the highest verbal projection with the verb. On this account, unstressed pronouns must cliticize to the verb and hence the derivation will be ill-formed at PF unless the particle strands in Agr (forced perhaps by something like the adjacency requirement on M<sup>0</sup> Merger posited in Bobaljik (1994)), ruling out the ungrammatical V-Prt-Pronoun order. This account is to be preferred over the “optional object raising” account of Koizumi for several reasons. First, if pronominals must move to SpecAgrIOP mandatorily to check some feature, it is perhaps surprising that prosodic heaviness can relax this requirement: stressing the pronoun renders V-Prt-Pro order (close to) grammatical<sup>11</sup>, as in 15) below:

15. He made out HIM to be a liar years ago.

On the account here, stressing the pronoun renders it phonologically heavy enough that it doesn't need to cliticize to the verb, and hence the V-Prt-Pro order is legitimate—a morphophonological effect, rather than a syntactic one.

<sup>9</sup>Koizumi (1995) terms it AgrIOP.

<sup>10</sup>For further discussion of “delimiting” arguments and inner aspect, see section 3.2.6.2 below.

<sup>11</sup>Bobaljik (p.c.) points out that this is true of Swedish pronouns as well: heavily stressed or modified pronouns behave like full NPs.

In addition, if the instances of V-Prt-Obj order resulted from incomplete raising of the object, with the particle in Spec-AgrIOP, as claimed by Koizumi (rather than from the particle raising to the upper projection along with the verb, as claimed here), Prt-Obj ordering would indicate the presence of a Prt-Obj constituent below the verb, dominated by  $\Omega$ P/AgrIOP. Prt-Obj, however, is clearly not a constituent, given the coordination example in 16b) below (cf. Stillings (1975)). The poorness of 16b) is predicted on the analysis here, where Prt-Obj order results when the particle remains attached to the verbal head, and hence never forms a constituent with the direct object to the exclusion of the verb. Several speakers that I consulted judge 16c) to be considerably better than 16b). The 16c) Obj-Prt coordination is predicted to be grammatical (i.e. Obj-Prt is a constituent) on either analysis; it is possible that its slight awkwardness is the result of conjoining (semantically empty) AgrPs.

16. a) Gary looked up [Sam's number] and [my address]. [V-Prt] [Obj]&[Obj]  
 b) \*Gary looked [up Sam's number] and [up my address].\*[V][Prt-Obj]&[Prt-Obj]  
 c) ?Gary looked [Sam's number up] and [my address up]. [V] [Obj-Prt]&[Obj-Prt]

### 3.1.3 *Quantifier float and the base position of objects in Japanese*

Koizumi also argues that object-shift data in Japanese indicate that the position of the case-checking, overtly shifted object is below the base-generated position of the subject. In Japanese, numeral quantifiers can appear outside the NPs they modify, but there are strict requirements on where such quantifiers can appear. They must be licensed by being adjacent to their host NP, or adjacent to its trace. No other placement is possible for these quantifiers (Miyagawa (1989)). We can thus use numeral quantifiers as a diagnostic for movement from a position—if a quantifier appears non-adjacent to its host, we know that there is a trace of its host in that position<sup>12</sup>. 17a) and b) below contain examples of

<sup>12</sup>This argument is superficially similar to the ISH argument from English and French quantifier float adopted in Sportiche (1988); however, the facts of Japanese numeral quantifier float are significantly different. For an extensive discussion of the untenability of the quantifier float arguments in English and French, see Bobaljik (1995).



overt movement of subject and object respectively to a case-checking AgrP, stranding a quantifier. (The quantifier and its host NP are italicized.)

17. a) *Gakusee-ga* *kinoo* *3-nin* *piza-o* *tabe-ta*  
*Students-N* *yesterday* *3-Cl* *pizza-A* *eat-Pst*  
 “Three students ate pizza.”
- b) *John-ga* *piza-o* *Mary-ni* *2-kire* *age-ta*  
*John-N* *pizza-A* *Mary-D* *2-CL* *give-Pst*  
 “John gave 2 slices of pizza to Mary”

In 17b) the object has moved to AgrO, across the indirect object. Now, consider the prediction made by the clause structure in 1a) above. If the subject were base-generated in a position below AgrOP, it should be able to shift, stranding a quantifier below the position of a shifted object in Spec-AgrOP. Such stranding is impossible, as seen in 18) below.

18. \**Gakusei-ga* *piza-o* *3-nin* *tabe-ta*  
*student-N* *pizza-A* *3-Cl* *eat-Pst*  
 “Three students ate pizza.”

However, if AgrO is below the position of base-generation of the subject, 18) is correctly ruled out, as there would then be no trace below the position of the shifted object to serve as a host for the floated numeral quantifier<sup>13</sup>.

### 3.1.4 Consequences of adopting stacked structures

Given that the Adjacency facts receive a more complete account if the phrase which projects the subject is syntactically separate from the phrase which projects the object, let us examine the consequences of this “split” approach to the projection of arguments for the problems discussed earlier. I suggest below that it has a number of empirical and conceptual advantages, drawing on similar proposals made by Bowers (1993), Kratzer (1993) and Travis (1991).

<sup>13</sup>Koizumi also presents evidence for the Split-VP Hypothesis from English quantifier float, assuming Sportiche’s (1988) claim that English quantifiers also mark NP-traces. There are substantive reasons to believe that this is not a correct characterization of the placement of English quantifiers, however; see Bobaljik (1995) for discussion.

### 3.1.4.1 *Case positions and $\theta$ -positions*

First, let us return to the basic conceptual problem with the subject-in-Spec-IP hypothesis noted above. Essentially, Spec-IP had to be characterized as always being a case position (to force Raising), and sometimes being a  $\theta$ -position (when external arguments were base-generated there). Positing the VP-internal subject hypothesis allowed Spec-IP to consistently be a case position but not a  $\theta$ -position, an attractive simplification of the theory.

The concomitant theoretical simplification involved the characterization of  $\theta$ -assignment. If all  $\theta$ -positions are internal to the VP, it is possible to describe  $\theta$ -assignment quite simply—the verb assigns  $\theta$ -roles only to XPs generated within its maximal projection, its external argument to the specifier of VP and its internal arguments to daughters of V'. That is,  $\theta$ -roles could be assigned under government by V.

If such a complete break between case positions and  $\theta$ -positions is desirable for subjects, it would seem reasonable to make such a break for objects as well. In Chomsky (1981), objects were assigned accusative case in the same position they received their  $\theta$ -role, that is, under government as sisters to the verb. However, the disjunction here went in the other direction: the sister-to-the-verb position was always a  $\theta$ -position, but sometimes not a case position. Accusative case could be assigned to the specifier position of a complement IP (again, under government) to an embedded subject that was  $\theta$ -marked by the embedded verb in instances of ECM. However, as we have seen in section 3.1.1 above, in such cases actual movement to the matrix clause for case-checking purposes (in a manner exactly parallel to raising-to-subject cases) seems motivated. (See the discussion of Case in Chapters 4 and 5 (esp. section 5.3). The Agr-based Case system of Chomsky (1992) accomplishes exactly the break between theta- and case-positions mentioned above:

$\theta$ -positions are positions governed by the  $\theta$ -assigning V, while (structural) case positions are the specifiers of AgrPs. We have seen above that on such an approach, the lower AgrP position must be below the position of base-generation of the subject. This implies that the subject is selected for by a head separate from that which selects and theta-marks the object—essentially, that the subject in a simple transitive sentence is not  $\theta$ -selected by the verb “hit” in the sense implied in, e.g. a lexical entry of the type assumed in Williams (1981). Williams has *hit* specified as selecting for two arguments, an Agent and a Patient; the distinction between external and internal arguments is indicated by a special diacritic on the Agent argument in the lexical entry. Instead, given the syntax for the verbal projection outlined above, “hit” must be represented in the syntax as (at least) two separate heads, the upper one of which selects the external argument of “hit” and the lower one of which selects the internal argument. The two, when combined by head-movement, are realized as “hit”. We will put off discussion of the actual verbal heads until section 3.2; here, we are concerned with the syntactic and semantic repercussions of the separation of the two.

This type of syntactic complexity for morphologically simple verbal forms is strongly reminiscent of the PP-shell analysis proposed in Pesetsky (1995) to account for double object constructions. On that account, null prepositional heads which mediate  $\theta$ -selection for “main” verbs are adjoined via head-movement to the lexical head which  $\theta$ -selects for the arguments they license. Such analyses are designed to account for the type of binding and constituency relations in double-object constructions alluded to above. The main difference between the Split-VP proposal outlined here and the type of shell architecture proposed by Pesetsky is that here we hold that *all* verbs are syntactically complex, not just those in double object structures, or those that select a Goal argument, but even a simple Agent/Patient transitive verb like “hit”. The complexity results from the *subject* being selected by a separate head in all cases, rather than some privileged objects being selected by separate heads. The articulation of the VP or PP shells in double object

constructions is obviously still necessary as well, as all of their arguments for the configuration of those constructions hold regardless of where the subject is generated. It seems, then, that the standard notion of a lexical entry for a verb, with  $\theta$ -roles (including the subject's) specified as arguments of a single verbal entity, is not reflected in the syntax<sup>14</sup>.

### 3.1.4.2 *Getting the external/internal distinction from the syntax*

Various proposals for establishing the internal/external asymmetry without base-generation in Spec-IP have been made which do not entail a separate projection for the subject. Notably, Marantz (1984) argues that lexical entries of the type described above do not exist: no specification for the external argument is contained in the lexical entry of a given verb. The lexical entry for, e.g. *hit* appears as in 19) below:

19. **hit** (theme)

His argument is based on the fact that verbs do not seem to receive special interpretations in combination with their subjects in the same way that they do (extremely productively) with their objects. V+Object, Marantz points out, can receive an idiosyncratic interpretation in a way that V+Subject combinations cannot. Examples of an object forcing a special interpretation on a verb can be seen in 20), from Marantz (1984).

20.

kill a bug	=	cause the bug to croak
kill a conversation	=	cause the conversation to end
kill an evening	=	while away the time span of the evening
kill a bottle	=	empty the bottle
kill an audience	=	entertain the audience to an extreme degree

---

<sup>14</sup>The VP/PP-shells proposal entails that for every internal argument of a verb, there is a separate (sometimes null) head that licenses it. The Split-VP Hypothesis entails that any external argument is selected by a separate head. The combination of the two might entail that for every argument projected, there is a separate head that selects it - essentially, neo-Davidsonian argument selection in the syntax. This proposal has been made in Noonan (1993), Déchaine (1993); it is crucially not adopted here, as some argument-projecting heads can be relational - cf. the discussion of the prepositions HAVE and LOC in section 3.2.5.

Note that these combinations are not frozen idiom chunks: the special interpretation of *kill* meaning “finish” can arise from combination with any comestible, not just a bottle (*kill the milk/peanuts/Baked Alaska*). No such special interpretations seem to be forced on verbs through combination with their subjects (to the exclusion of the object)<sup>15</sup>.

This type of distinction between internal and external arguments, Marantz argues, is a reflection of the fact that the V+Object combination forms a predicate. The subject, then, is not an argument of the verb, but an argument of the predicate, and hence the verb cannot impose any selectional restrictions on the subject to the exclusion of its object. Any selectional restriction will necessarily be imposed by the predicate, that is, the V-Object combination.

Kratzer (1993) argues that this type of characterization of a “predicate” cannot be adequately semantically represented, and has argued that the only way to implement this type of external/internal argument distinction in a semantically satisfactory way is to assume

---

<sup>15</sup>Ken Hale (p.c.) has pointed out a possible counterexample to this generalization from Diné (Navajo), noted also in Marantz (1984). An idiom corresponding roughly to the English phrase “kick the bucket” appears to be a Subj-V idiom, with the direct object being the semantically unrestricted argument. An example appears in i) below

i)           naalyéhé yá sídáhi yéę   deeleel                   yáábí’iisha’  
           The (former) traitor       broad horns       up-him-toss

          “The moose tossed the former traitor (on his horns)” = “The traitor kicked the bucket”.

In this example, the subject seems to be unquestionably agentive, and hence may be a true counter-example to Marantz’s generalizations. In other putative psych-verb counterexamples from Athapaskan noted in Saxon and Rice (1993), Rice and Saxon (1994), the subjects do not seem to be agentive; it should be possible for a verb to be in a special relation with an *internal* argument which subsequently raises to subject position. Here we argue that only external arguments—that is, especially, agent arguments—cannot be involved in such an idiom. See also the further discussion of Athapaskan idioms in Chapter 5.

Jonathan Bobaljik (p.c.) suggests that sentences such as “That joke killed me” constitute a counterexample as well, in that the special interpretation seems to be arising from the combination of the subject “that joke” and the verb “kill”; I would rather suggest that the special interpretation is still arising from the V+O combination, given that in this situation “me” is understood as “an audience”, c.f. the last example in 20) above; admittedly, this interpretation of “me” is suggested by the subject “that joke”, but not forced by it (the same reading can be achieved with “that comedian” “that movie” etc.). The fact that “that joke” is inanimate also complicates the issue, involving, perhaps, the problem with *Aktionsarten* discussed by Kratzer in sentences like “The apples fed the horse” vs. “The groom fed the horse” (see discussion in this section, below). A final note on this example: in this instance “kill” seems to behave like an “object experiencer” verb, as it is possible for an embedded subject reflexive to be anteceded by the object: “Jokes about himself<sub>i</sub> always killed John<sub>i</sub>”; cf Pesetsky (1994).

that the external argument is licensed by a separate head in the syntax, contra Bresnan (1982) and Grimshaw (1990). Consider the alternations in (20) above. Kratzer argues that there are two possible ways of approaching the semantic representation of these alternations. On either of these approaches, she points out, the mechanism that is used to specify that the V+Object combination triggers a special interpretation could be used equally well to specify that a V+Subject combination triggers such an interpretation, if subjects are true arguments of their verbs. Since no such combinatory interpretations seem to occur, however, we must conclude that subjects are not true arguments of their verbs.

Let's consider her argument in some detail, given a standard ISH structure<sup>16</sup>. One of the two possible treatments of these alternations, she suggests, is that there are several different homophonous verbs *kill*, each of which semantically selects for a different type of object. *Kill* meaning "waste" would produce an uninterpretable sentence if paired with any object that did not denote a time interval (much like "kick" in its most prosaic use produces an uninterpretable sentence if paired with a non-corporeal object: #*kick the adjective*). This type of restriction on an inner argument can be implemented by including a statement in the semantic representation of the verb along the lines of "the function  $f$  is only defined for individuals that satisfy <a given restriction>". The problem is that that type of statement could be made about any element in the argument structure of the verb, no matter where in that argument structure a given element is. For example, in order to specify a restriction on the external argument, independently of the internal argument, the representation could include a statement along the lines of "for any individual  $a$  in the domain of  $f$ ,  $f(a)$  is only defined for individuals that satisfy <a given restriction>".

---

<sup>16</sup>This argument holds as well if the subject is not internal to a VP, but adjoined to it (as in Hale and Keyser (1991)); as long as the subject is dominated by a segment of the projection of the verbal head, no differentiation between the subject argument and other arguments of the verb can be represented semantically.

Consider another possible approach to the alternations in 20): There is only one verb “kill”, but its representation includes specifications for special interpretations when it is combined with objects of different types. *Kill* would be a function with a Theme and an Agent,  $f(a)(b)$ , that would assign truth to an individual  $b$  if  $b$  kills  $a$  when  $a$  is an animate entity, if  $b$  wastes  $a$  when  $a$  is a time interval, if  $b$  finishes  $a$  when  $a$  is an edible item, etc. If this were a correct account of the alternations in 20), again, one would expect semantic representations to be able to specify special interpretations for any argument, internal or external. The function “kill”,  $f(a)(b)$ , could assign truth to an individual  $b$  if  $b$  spits on  $a$  when  $b$  is a llama. This is exactly the type of subject-verb combination that Marantz points out does not appear; hence, “kill” does not select its subjects.

Kratzer maintains, then, following Marantz, that external arguments cannot be part of a verb's semantic representation—verbs are functions like those suggested by Marantz, above, taking only internal arguments.

Consider the way in which Kratzer assumes the syntax represents the combination of a verb and its arguments. Semantic composition proceeds via Functional Application: the verb is a function, its sister is an argument of that function. The combination of the two yields the semantic representation of their mother node. This semantic composition via sisterhood can continue within the projection of the verb until the function denoted by the verb is completely saturated. (See the picture of functional application for a function with three arguments in 21).

21.

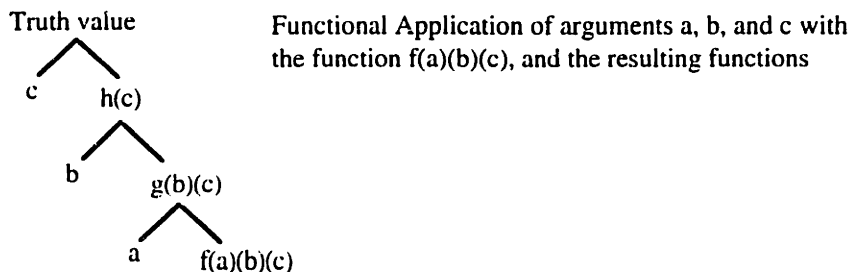

Now, consider the situation if the external argument is generated in Spec-VP or adjoined to the VP. The denotation of the sister of the subject (that is, V' or VP) is whatever the result of combining its daughters (the verb and its object) via Functional Application was. Now, the subject and its sister node must be similarly combined. Unless the V' or VP sister node is an unsaturated function, however, Functional Application cannot take place. The only way for the V' or VP node to get the denotation of an unsaturated function is for the output of Functional Application of the verb and its object to be such an unsaturated function, and the only way for such output to arise is if the function denoted by the verb required at least two arguments to become saturated—that is, if the verb actually selected for both the internal and external arguments to begin with. This, of course, is the situation that the above discussion of verb-object interpretations suggested was impossible. The only possible way to reconcile the requirements of the syntax (Functional Application) and the semantics (lack of external argument in the verb's lexical entry), Kratzer argues, is to assume that the subject appears as the argument of an entirely separate head, and is not part of the verbal projection that selects the object at all. This is precisely the situation motivated for purely syntactic reasons above.

Kratzer proposes a special kind of conjunction she terms “Event Identification” to effect the (eventual) combination of the VP with the head that projects the subject, which she terms “Voice”. The denotation of Voice is a function that takes an individual (e) and maps it to a function from events (s) to truth-values (t) ( $\langle e, \langle s, t \rangle \rangle$ ). Event Identification



combines this denotation with the denotation of the VP, a mapping from events to truth-values ( $\langle s, t \rangle$ ), to produce a function of the type that takes an individual and maps it to a function from events to truth values ( $\langle e, \langle s, t \rangle \rangle$ ). An example of this operation can be seen in 22) below (Kratzer's ex. 19):

$$\begin{array}{ccc}
 \text{22.} & \begin{array}{c} \text{(Voice)} \\ f \\ \langle e, \langle s, t \rangle \rangle \\ \lambda x_e \lambda e_s \text{Agent}(x)(e) \end{array} & \begin{array}{c} \text{(VP)} \\ g \\ \langle s, t \rangle \\ \lambda e_s \text{wash}(\text{the clothes})(e) \end{array} & \longrightarrow & \begin{array}{c} \text{Voice'} \\ h \\ \langle e, \langle s, t \rangle \rangle \\ \lambda x_e \lambda e_s [\text{Agent}(x)(e) \& \text{wash}(\text{the clothes})(e)] \end{array}
 \end{array}$$

The plausibility of the above proposal rests heavily on the argument from Marantz that there is no real selectional relation between a verb and its subject, such that the “external” argument of the verb is really not an argument at all. There is a class of subject alternations noted by Kratzer that initially appear problematic for this stance. Consider the examples in 23) below:

23. a) The bushel of apples fed the horse.  
 a') The groom fed the horse.  
 b) The rhinestone wallpaper emphasized his bad taste.  
 b') His mother emphasized his bad taste.

The choice of subject here seems to trigger an alternation in verb interpretation. Animate subjects allow an action interpretation, while inanimate subjects force a non-action interpretation. Kratzer points out, however, that this type of alternation is significantly different from the fairly idiosyncratic nature of the alternations listed in 20). Interpretations triggered by the subject are always of the type noted above—they involve forcing the type of event denoted by the verb to match the type of the event of which the subject could be the initiator. Thus, the inanimate subjects in a) and b) force a non-action interpretation, as they could not be agentive (except in some cartoon-type scenario). Kratzer argues that this is purely a condition on matching event types: the event type of both of the functions that undergo Event Identification must be the same; essentially, a condition on the *Aktionsarten* of the two functions being conjoined. We therefore expect that the only type of variation in verb interpretation that can be imposed by the subject will have to do with the event types it is possible to associate with the subject.

### 3.1.4.3 *External vs. internal VPs and adverb type: Bowers (1993)*

Given the above discussion, we can conclude that the two heads which project the external and internal arguments in a given clause are of different types—that is, the top head is not simply an empty V slot waiting to be filled by a conventional external-argument selecting verb, *à la* Larson. Koizumi (1993) concludes that the subject-projecting head is in fact a V head, along Larson’s lines (hence “Split-VP Hypothesis”) on the basis of adverbial facts. Assuming a strict licensing requirement on adjunction of adverbs to XPs—that is, a specific type of head licenses the adjunction of a specific type of adverb to its XP—the fact that an adverb like “quickly” in 24) below can adjoin to either the XP that projects the subject (where the verb appears at Spell-Out) or to the VP that projects the object seems to demonstrate that these two heads are of the same category.

24. Acme (quickly) sold Wily the bombs (quickly) for \$0.25 (quickly).

Koizumi thus concludes that the upper head must be of type “V”, as is the lower head, since the same adverb can adjoin to both projections. This conclusion, however, is not necessarily warranted.

Bowers (1993) points out that in addition to the type of “put it anywhere” adverb exemplified by *quickly* above, there is another type, which can only appear postverbally, never preverbally. This type is exemplified in 25) below:

25. a) Schroeder played the piano beautifully.  
b) \*Schroeder beautifully played the piano.

The stricter restriction on the distribution on the second type of manner adverbial suggests that it is of a different class than the *quickly* type in 24). The two types can co-occur, with the former type in either position, but the positions of the two can never be reversed.

26. a) Schroeder quickly played the piano beautifully.  
 b) Schroeder played the piano beautifully very quickly.  
 c) \*Schroeder beautifully played the piano quickly.  
 d) \*Schroeder played the piano quickly very beautifully.

So far, then, we have adverbs that can appear preceding the verb and adverbs that can appear following the verb<sup>17</sup>. Bowers notes that there are two additional types of adverb in English, both of which can co-occur with any of the others and whose positions cannot be reversed with any of the others. I will only provide an example sentence with the four types occurring grammatically; the reader is referred to Bowers for the tests involving reversal of the positions of any of these adverbs.

27. Clearly Schroeder probably has quickly played the piano beautifully.

Now, note that on the strongly restricted hypothesis about adverb adjunction we are espousing here (c.f. Travis (1988)), four different heads are required to be licensers for these four types of adverbs. Comp and Tense (Infl) are likely candidates for the first two. On a characterization of clause structure with only one VP, or, alternatively, where the subject- and object-projecting heads are both of type V, there doesn't seem to be two plausible candidates for different licensers for the remaining two types of adverb. In particular, the second, more restricted type, is especially left without a characterization. It has been proposed that the second type is licensed as adjoined to the V°, while the first type may adjoin to V' or VP. There are three problems with this type of approach. The first is that noted above—if adverbs are licensed by the category of the projection they adjoin to, there is still not a sufficient principled distinction between the two types of adverbs, as they

---

<sup>17</sup> Bobaljik (p.c.) suggests that (with some verb types) it is only the inflected main verb which must appear to the left of the second type of VP adverbial; participles may appear to their right, suggesting that short verb movement only applies to inflected verbs:

- i) The climber has beautifully executed the moves.  
 ii) The moves were beautifully executed by the climber.

This is not true for some verb types; iii) sounds quite odd to the English speakers I consulted:

- iii) ??Schroeder has beautifully played the piano.

If there is a difference between the movement possibilities for inflected and participle verbs, it is evidently not connected to the account of the Adjacency facts presented here, as adverbs still may not intervene between a participle and its object:

- iv) \*The climber has executed beautifully the moves.

I leave the contrast between i) and iii) for future research; however, for some thoughts on the structure of auxiliaries, see the discussion in 3.2.6.1 below.

are both adjoining to elements of category V. The second, noted by Bowers, is that if the restricted type appears at PF as sister to the verb, there is no explanation for why it can only appear postverbally, as adverbs can generally freely right- or left-adjoin. Thirdly, on the assumptions entailed by Koizumi's account of the Adjacency Condition above—that is, that adverbs must adjoin to maximal projections—adjunction to  $X'$  or  $X^\circ$  projections is prohibited.

All of these problems are resolved if the two heads of the Split-VP hypothesis are of different types, each of which can license a different type of adverb. The inner, object-selecting head licenses the type of manner adverb which always appears postverbally, while the outer, subject-selecting head licenses the less restricted type. The more restricted adverbial can only appear post-verbally because the verb (and direct object) undergo short V-movement to the upper subject-projecting head in the overt syntax as outlined above; hence, no matter which side of the embedded VP projection they appear on, these adverbs will always be postverbal. Note that they can appear to the right or left of a complement PP, reflecting right- or left-adjunction in the syntax (28). (In 28) I use “SubjP” to refer to what above was the upper projection, so as to be neutral as to the category of the head. We will begin discussion of what categories might be possible candidates for this head in section 3.2.)

28. a)

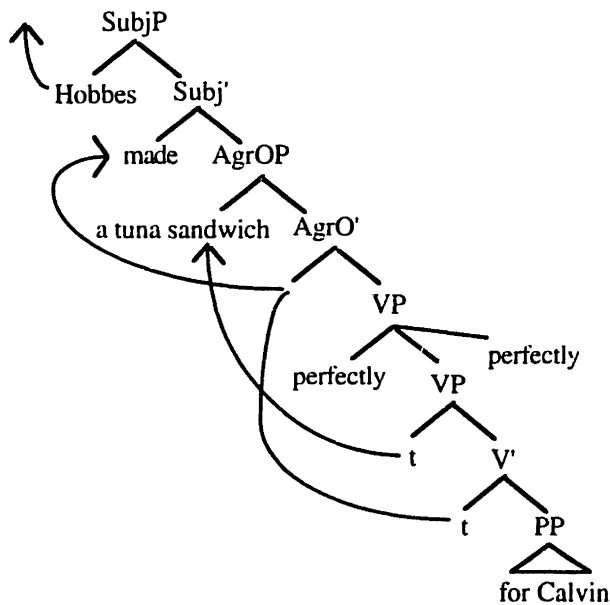

- b) Hobbes made a tuna sandwich perfectly for Calvin.
- c) Hobbes made a tuna sandwich for Calvin perfectly.

Given that the two adverb-licensing heads here are of different types, the class of *quickly* adverbs alluded to above that can apparently be licensed by either projection might appear to be problematic. As noted in Bowers, these less restricted manner adverbs can apparently be licensed by either of the subject- or object-selecting heads. Examples like 29) are perfectly felicitous:

29. Schroeder played the sonata nether quickly nor perfectly.

Such postverbal conjunction should only be possible if these adverbs (*quickly* and *perfectly*) are of the same type. Bowers argues that *quickly* can be of either type, and cites a telling difference in interpretation between the two possible positions for *quickly* in support. If *quickly* in postverbal position (*Schroeder played the piano quickly*) is licensed by the subject head, it should have the same interpretation as *quickly* in preverbal position (*Schroeder quickly played the piano*)—that is, that (in response to something, say) Schroeder speedily began an act of playing the piano, or that the entire event of playing the piano was over quickly. When *quickly* is licensed by the object head, however, it describes the rate at which he played the piano. The former, subject-projection-adjoined use of

*quickly* can be true even if Schroeder is playing a very slow waltz, but the latter, object-projection-adjoined *quickly* can only be true if he is playing more or less *allegro*. Crucially, in 29), where *quickly* is conjoined with an adverbial that may only appear postverbally, the most felicitous interpretation of *quickly* is the latter. Further, it is perfectly reasonable to allow two occurrences of *quickly*, one of each type, in the same sentence:

30. Schroeder quickly played the sonata quickly.

Note that an interesting property of the subject-projection-adjoined *quickly* is that it modifies the aspect of the event of piano-playing, characterizing it as starting in a quick way, while the object-projection-adjoined *quickly* modifies the piano-playing itself. We will return to this significant fact in section 3.2 below.

### 3.1.5 *The Story So Far*

To sum up the discussion so far, then, we have concluded that subjects are base-generated in a phrase that is the complement to TP. Crucially, however, this phrase is not a VP in the commonly-accepted sense. Several arguments for an articulated analysis of the VP were presented, ranging from ECM infinitives in Icelandic to facts of adverbial placement in English to the semantic consequences of taking the notion of “external argument” literally. I have thus far remained agnostic about the category of the phrases that select for/project the subject and the object; we turn to this issue now in section 3.2.

## 3.2 *Events, Agents and “verbs”*

In the previous section, we have seen some of the reasons to assume that the projection in which subjects are generated is separate from the projection that is responsible for object projection—that is, that the VP in the canonical sense does not exist. Here, we will briefly investigate the nature of the projections that make up verbs and propose that the

conservative version of the distinction between lexical syntax and clausal syntax is a spurious one. What Hale and Keyser (1993) refer to as *l-syntax* can be identified structurally, as it is delimited by iterations of a purely verbal category.

A VP<sup>18</sup> with an external argument, then, inevitably contains at least two heads: that which projects/selects the external argument, and that which projects/selects the internal argument(s)<sup>19</sup>. The issue here is how to properly characterize the content of these heads, particularly the top head, which projects the external argument.

We will approach this question in a somewhat roundabout fashion.

### 3.2.1 *L-syntax: deriving the lexicon*

#### 3.2.1.1 *How many theta-roles? Hale and Keyser's question*

Hale and Keyser (1991, 1993) note that on a view of the lexicon in which verbs have  $\theta$ -roles to assign, listed in their lexical entry, there seems to be no explanation for the curious paucity of  $\theta$ -roles. Presumably,  $\theta$ -roles could be just as idiosyncratic as any information that must be listed in the lexicon as underivable from independent properties of the verb. On such a view, they argue, there is no obvious reason why there should not be twenty different  $\theta$ -roles, or two hundred, rather than the five or six that are usually assumed. They propose an account of this fact that relies on decomposing verbs into component primitives, (essentially) suggesting that the number of  $\theta$ -roles is limited because the number of primitives is limited. Apparent  $\theta$ -roles are the result of arguments entering

---

<sup>18</sup>I use "VP" here to refer to the minimal projection that contains all the arguments in a given clause - essentially, the structure headed by "SubjP" in example 28a) above. It should be re-emphasized, however, that this is purely a notational convenience for the nonce.

<sup>19</sup>I will assume Hale and Keyser's (1991) contention that there are no true "objectless" verbs; unergatives are disguised transitives. We will discuss this question further in 3.2.4.1 below.

into structural relations with these primitives (specifier of, complement of), which combine to form the lexical verb that appears to assign  $\theta$ -roles. I propose to adopt the view that these primitives are the heads of the various shells labeled “V” in the previous chapter, contra, e.g., Larson (1988) and Pesetsky (1994), but in line with, e.g. Travis (1991), (1994).

In Larson (1988), the shell-projecting V-heads which provide a syntactic slot in which arguments of double object constructions appear are purely empty, and the verb satisfies its selectional requirements during the course of the derivation as it moves into each empty head and saturates its argument structure. For Larson, a verb is still listed in the lexicon as a function requiring a certain number of arguments of certain types, and there is presumably still no way to derive a restriction on the number or type of arguments it is possible for a verb to have.

For Pesetsky (1994), shells are headed by contentful Ps, which mediate theta-assignment for the verb, thus satisfying its selectional restrictions. Locality restrictions on mediated theta-assignment ensure that no more than two internal arguments can be selected for by any one verb; any more, and the structural requirements on mediated theta-assignment would not be met. This type of proposal is a step closer to answering the question posed by Hale and Keyser, in that the *number* of arguments is limited in a principled way, but there is still no answer to the question of how to derive the crucial limitations on argument *type*; on such an approach, presumably, there could still be any number of  $\theta$ -roles, any one or two of which could be assigned to internal arguments<sup>20</sup>.

---

<sup>20</sup>For Pesetsky, this is an intended result, as the class of “object experiencer” verbs which he deals with require on his argument a finer-grained notion of theta-role than commonly assumed, and it would not prove surprising on his analysis to discover that 50 or 100 theta-roles were necessary. We will not attempt a counteranalysis here, merely note that object experiencers as a serious problem for future study.



Deriving the restriction on the number of arguments it is possible for a verb to have via locality constraints, then, is a less than perfect solution (although a much-proposed one<sup>21</sup>)

Hale and Keyser (1991), (1994), Hale (1995) propose that the argument structure of a verb is purely the result of principles governing the lexical syntax. Combinations of lexical primitives (see section 3.2.4.1 below) result in syntactically complex, yet often monomorphemic “verbs”, which then enter the syntax, combining with argument DPs to satisfy basic relations imposed by their lexical structure. Crucially, the lexical structure contains no “lists” of arguments, nor of theta-roles that must be assigned, as on more familiar approaches to argument structure like those in Williams (1993) or Grimshaw (1990). Their approach, they are quick to point out, is compatible with the notion of lexical insertion and hence compatible with, for example, a Larsonian approach to VP-shells: these structures could be in the lexicon in some sense, *in place of* the lists of  $\theta$ -roles. They draw a sharp distinction between this type of syntax (l-syntax) and clausal syntax of the more familiar type, although the principles governing the well-formedness of the structures are the same in both types. Many discussions of their work blur the distinction between the two types (e.g. Chomsky (1993): 14); I propose to abandon it.

### 3.2.1.2 Voice?, unaccusatives and agents

Let us approach the notion of lexical decomposition via the proposal of Kratzer (1993) outlined in section 3.1.

---

<sup>21</sup>The revised version of Rizzi's (1990) Relativized Minimality proposed in Chomsky (1992, 1993) in terms of Equidistance in combination with an Agr-based account of case-checking, for instance, interact to prevent a verb from having more than two structurally-case-checked internal arguments, as laid out in Collins and Thráinsson (1993) for double object constructions, and in Watanabe (1994) and Harley (1995) for locative inversion and psych verb constructions. This interaction seems to achieve the desired result; however, it has the flavor of a coincidence, and still fails to provide any explanation for the central question about argument type posed by Hale and Keyser. Further, the primary motivation for Equidistance was to allow case-checking of the object above the position of base-generation of the subject, and in a split-VP clausal architecture, this is no longer necessary. See further discussion, however, in section 5.3 below.

For Kratzer, the external-argument-projecting head is a “VoiceP”. It can contain two possible abstract heads, one that selects an external argument, and one that doesn't. Alternations between unaccusative/transitive pairs, or active/passive pairs, are the result of variation in whether the Voice head selects an external argument or not. Consider the standard unaccusative/transitive pair in 30) below:

30. a) Dandelions grow.  
b) Opus grows dandelions.

On Kratzer's analysis, the external argument in 30b) *Opus* is introduced by an argument-selecting Voice head, and in 30a), the movement of the internal argument *dandelions* to subject position is forced because the non-argument-selecting Voice head projects no argument to satisfy the EPP, and there is no accusative case available for the internal argument. (Burzio's generalization, for Kratzer, is the result of case-assignment by the argument-selecting Voice head. For discussion of Burzio's generalization under the assumptions here, see section 5.1 in chapter 5 below).

The example in 30b) can in be intuitively decomposed into the meaning of 30a) plus a notion of causation, as originally noted in the classic “cause to die” examples in the generative semantics literature (as discussed, e.g. in Fodor (1970)). 30b) means something close to “Opus causes dandelions to grow.” A well-known argument for such decomposition is that a lexical nominalization of the verb “grow” has no causative force (Chomsky (1970)), as evidenced in 31):

31. \*Opus's growth of dandelions<sup>22</sup>.

This asymmetry is easily captured in Kratzer's approach. This type of nominalization is formed from a constituent or head that does not include VoiceP; hence, no external “causer” argument can appear in the noun's argument structure. This approach is

---

<sup>22</sup>There are nominalizations of verbs which *do* have causative force, of course; “John's destruction of the city” from “destroy” is an example of one such. Such nominalizations admit of no obvious explanation on the l-syntactic structures here, see, however the discussion of “mandatory agents” in 5.4.

motivated even for verbs that do not undergo the transitive/unaccusative alternation—that is, for verbs that always have an external causer argument. An example of such a verb and its nominalization is seen in 32) below: the nominalization can have no causative force whatever.

32. a) Opus amused Ronald-Ann  
b) \*Opus's amusement of Ronald-Ann

Although Kratzer makes no specific proposal about the content of the external-argument-selecting head of Voice, it seems reasonable to suppose that it can at least sometimes correspond to an abstract CAUSE morpheme—that is, that “Causer” or “Agent” arguments are projected in the specifier of this head. This was proposed for the shells of Pesetsky (1994); the impossibility of nominalization was attributed to a ban on affixation to a zero morpheme.

### 3.2.1.3 “Kill” as “cause to die”: event structure

The decomposition of monomorphemic agentive verbs into “basic” phrases like “cause to die” was argued against in its original, generative semantic, incarnation by Fodor (1970). Essentially, the problem he raises with the attempt to represent words as underlyingly phrasal elements is that the event structure of “kill” is not the same as that of “cause to die”. In the former, there is but one event, in which the action of the agent is directly responsible for the death of the patient; in the latter, the causation is a separate event, which results in the event of dying. This two-event structure of “cause to die” provides two possible domains for “do so” ellipsis, adjunction of time adverbials and control of instrumental adverbials, which are his “three reasons” against such decomposition of “kill”<sup>23</sup>. The notion of decomposition we need, then, is not one in which

---

<sup>23</sup>For instance, the event of dying and the event of causing can be temporally distinct in “Mary caused John to die on Saturday (by shooting him on Friday)” but not in “Sue killed Bill on Saturday (\*by shooting him on Friday)”. Fodor’s other arguments also hinge on the presence of an embedded IP and hence an embedded Event in the “cause to die” examples but not in the “kill” examples.

“kill” is represented as “cause to die”, complete with its two-event syntax, two tense morphemes, etc., but one in which the abstract CAUSE morpheme is part of the same event as its complement. It is the introduction of the event argument that divides Hale and Keyser’s I-syntax from the clausal syntax, and divides the VP from the rest of the clause; a reflex of this division is that verbal heads in English combined within the EventP will be realized as verbs, (giving, e.g. “CAUSE+[some verb]=“kill”). The VP-Internal Subject Hypothesis, then, is really a hypothesis about event structure. Kratzer’s “Voice” head, which can select or not select an external argument, implements the intuition that a verb phrase denotes an event, which can be initiated by an agent or not. I rename it EventP, below, to capture this intuition. (There seems to be some convergence occurring on this issue; Travis (1994) has independently reached the same conclusion with respect to data from Malagasy causatives, and gives the relevant head the same name).

For future reference, I include here a sample tree, with the domains of I-syntax and clausal syntax clearly indicated. (See Nash (1994):168 for a similar diagram):

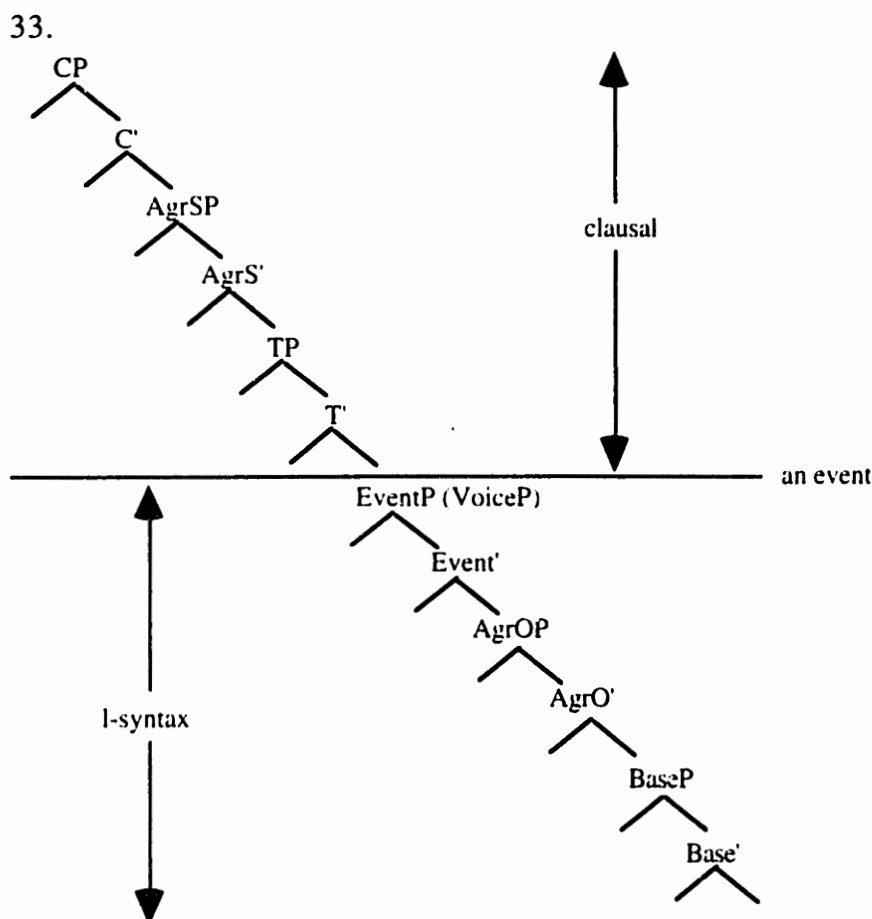

In English, the arguments for such decomposition are largely conceptual in their simplest form. Hale and Keyser (1993) provide extensive evidence that the formation of verbs is subject to syntactic constraints, and hence should be syntactically represented; however, external arguments of the type generated in the specifier of EventP are for them not selected by a separate head. The notion of actual decomposition of verbal forms in the syntax is thus not articulated by Hale and Keyser in the sense we want here. We will examine their arguments in section 3.2.4 below; for now, we turn to Japanese for morphological and semantic evidence for the l-syntax and clausal syntax distinction.

### 3.2.2 *Lexical Japanese causatives: l-syntax and Late Insertion*

Here I will begin a prolonged discussion of the Japanese causative morpheme *-(s)ase-*. This morpheme always appears in a phonological word consisting of a verbal root

V, *-sase-*, and any tense or other inflectional material. I am primarily concerned in this section with the conditions under which this morpheme is analyzed as “lexical”, that is, as part of a single-event-denoting “word”, as opposed to the conditions under which this morpheme is analyzed as “syntactic”, when two events, one associated with causing one associated with the embedded verb, are clearly represented. The parallel with the “kill” (“lexical” causative) vs. “cause to die” (“analytic/syntactic” causative) examples is very close here, except that the abstract CAUSE morpheme in the former and the matrix “cause” verb in the latter can both be overtly realized in Japanese as the same causative morpheme *-sase-*. The possible difference in interpretation between two identical verb+*sase* combinations, one lexical and one analytic, is the result of whether or not two events are implicated by the complex verb+*sase*—that is, whether or not the *-sase-* morpheme realizes a CAUSE morpheme that encodes an event separate from the event associated with the verb. The crucial similarity the lexical causative shares with “kill” is the strong intuition of native speakers of Japanese that the lexical causative is a “word” with unanalyzable meaning, which can undergo semantic drift in the same way as monomorphemic verbs, and receive an idiomatic interpretation. The syntactic causative, however, cannot receive an idiomatic interpretation; it must always be interpreted compositionally, as “cause to V”. Other tests for lexical vs. syntactic status for a given V+*sase* combination will be outlined and employed in section 3.2.2.3 below.

### 3.2.2.1 “Lexical” vs. “analytic”: interpreting V+*sase*

The morpheme indicating causation in Japanese can form two types of causativized verbs: one that is analyzed as “syntactic” (Kuroda (1965) and one that is thought of as “lexical” (Miyagawa 1980, 1984, 1986, 1989). Most treatments of the two types separate them: the former is considered to head a verbal projection in its own right, analogous to English *make*, and the latter is considered a derivational morpheme, attached by some

mechanism in the lexicon (Kuroda (1994). The former's meaning is always compositional, while the latter's meaning is often idiomatic and unanalysable (though always causative).

The syntactic causative can attach freely to any verbal head, just as English “make” can take any TP as a complement, to produce a causative structure of the “cause to die” type. The lexical causative, however, is not so freely attachable. Miyagawa (1989) characterizes its pattern as follows: lexical *-sase-* can attach to any verbal stem, thereby adding a causer argument, just in case that verbal stem does not have another form (zero-derived or otherwise) that already has an additional argument. Essentially, addition of a lexical causative affix to an intransitive verb is blocked if that verb has an (otherwise derived) transitive counterpart; similarly, addition of a lexical causative affix to a transitive verb is blocked if that verb has an (otherwise derived) ditransitive counterpart.

This “blocking” effect leads Miyagawa (1989) to posit a level of “Paradigmatic Structure” (PDS) between the lexicon and the syntax, where lexical causatives can be formed if there is no independently formed element in the lexicon occupying the “slot” (corresponding to a cell in the table in 34) below) in the PDS that would be filled by affixation of the causative morpheme to the verb stem. An example is seen in 34) below:

34.

	Intransitive	Transitive
a)	<i>niow smell</i>	<i>niow-ase hint</i>
b)	<i>koe become rich</i>	<i>koyas enrich</i>
		<i>*koe-sase enrich</i>

In 34a), there is no lexical item occupying the transitive slot corresponding to intransitive *niow* “smell”, hence the addition of the “transitivizer” *-sase-* is well-formed, giving the lexical causative *niow-ase* with the noncompositional meaning “hint”. In 34b), however, there is a lexical item *koyas* “enrich” occupying the transitive slot corresponding to intransitive *koe* “get rich”, and this blocks the affixation of the lexical transitivizer *-sase-*.

Miyagawa (1980) notes that similar facts exist in Mitla Zapotec. The causative prefix *s-* in Mitla Zapotec can attach to intransitive verbs, giving a meaning of “cause-V”, just in case there is no other transitive counterpart with this meaning. Examples of a legitimate and blocked addition of the causative *s-* can be seen in 35) below<sup>24</sup>:

35.

	Intransitive	Transitive
a)	ni? <i>move</i>	s-ni? ( <i>make</i> ) <i>move</i>
b)	ri? <i>come/go out</i>	Læ? <i>take out</i>
		*s-ri? <i>take out</i>

This provides a satisfactory characterization of the blocking effect that Miyagawa observes for the lexical causative, and maintains a sense in which the lexical *V+sase* combination is an item in the lexicon. Miyagawa argues that his analysis of the lexical causative as a word-level item (generated before the syntax proper) provides an explanation for the difference in the possibility of idiom-formation between the lexical and the syntactic causative: the former can participate in idiom formation, while the latter cannot. Take the instance of blocking in 36) below:

36.

Intransitive	Transitive
tobut <i>fly</i>	tobas <i>dismiss</i>
	*tob-ase <i>dismiss</i>

Miyagawa (1994) notes that the idiomatic meaning of the transitive verb *tobas* cannot be expressed by affixation of *-sase-* to the intransitive stem “fly”. Such affixation is necessarily syntactic, not lexical, due to the blocking effect induced by the stem *tobas* (*tob-ase* is a well-formed complex verb with a biclausal interpretation, “x made y fly”), and hence *tob-ase* cannot receive the necessarily lexical idiomatic interpretation.

<sup>24</sup>Similar facts exist in Malagasy and Tagalog (Guilfoyle, et al. (1992), Travis (1994))



### 3.2.2.2      *The “Elsewhere” rule: Late Insertion*

This type of distinction between the lexical and syntactic *-sase-*, however, seems to miss a generalization, as pointed out in later work by Miyagawa (1994). If syntactic *-sase-* is a verb that takes a clausal complement, while lexical *-sase-* is a derivational morpheme that affixes at some late stage in the lexicon like PDS, there is no reason why they should be morphologically related at all. It is surely more than a coincidence that this element, meaning in one instance abstract CAUSE and in another “to cause”, can be realized using exactly the same morphophonological form in the two cases.

Miyagawa (1994) proposes a unified approach to the lexical and syntactic affixation of *-sase-*, arguing that in both cases, affixation is syntactic. Rather than positing an intermediate level of PDS, in which a cycle of lexical affixation of the “transitivizing” *-sase-* takes place if there is no previously-formed transitive counterpart to a given verb, he proposes that all affixation of causative morphemes takes place in the syntax. Given the existence of I-syntax à la Hale and Keyser, he proposes that *-sase-* is an “Elsewhere” causative. The proposal makes crucial use of post-syntactic insertion of lexical items—Late Insertion, as proposed in Halle and Marantz (1994).

A “Late Insertion” view of lexical realization holds that information about the phonological realization of a given terminal node in the syntax is only available in some subpart of the derivation, on the way to PF component. For all syntactic purposes, the word “cat” is equivalent to the word “dog”; information about the identity of an item that is not purely syntactic in nature (e.g. its canine vs. feline qualities, or its phonological realization) is not represented in the syntax. The phonological realization of terminal nodes is inserted on the way to PF, where it undergoes whatever morphological operations are necessary. (A canonical case, for instance, involves the realization of the “plural” terminal

node in English: the special plural form *-en* blocks the realization of the default *-s* in the environment of the form *ox*; the syntax, however, doesn't recognize any difference between the plural of "ox" and the plural of any other noun.) For the purposes of the syntax, then, /kæt/ = /dag/ = {N, animate, -human ...}.

Recall that (so far) we have assumed the syntactic reality of a CAUSE element, which can occupy the Event head (Kratzer's Voice). Miyagawa (1994) assumes that this element is present in all lexical causatives, whether they are monomorphemic, formed with a morpheme other than *-sase-* or formed with lexical *-sase-*, just as the evidence from nominalizations points towards the presence of such a head in English *annoy*. The blocking effect is not produced by blocking effects on insertion operations in a separate post-lexical, pre-syntactic level of structure like PDS, but by the well-known Paninian "Elsewhere" condition, already necessary elsewhere in morphology. Essentially, the CAUSE head is subject to spell-out conditions like those seen everywhere in morphology. If there is a more "specific" form (Vocabulary Item) for CAUSE (e.g. zero or some other idiosyncratic morphological realization according to class membership (cf. the sixteen different classes of inchoative/causative pairs listed in Jacobsen (1992))<sup>25</sup>, the CAUSE head is realized as that form, while if there is no specification, CAUSE is realized as the Elsewhere form—*sase-*.

The paradigm Miyagawa is accounting for is seen in 37) below; the (partial) set of ordered Vocabulary Items he proposes is seen in 38) (Miyagawa (1994) ex. (38)). (The reference to BECOME in 38a)-c) below is not particularly important for our purposes here; it refers to a stative verbal head embedded in I-syntactic structures which we do not employ.)

---

<sup>25</sup>The PDS approach assumed in Miyagawa (1989) appeals to essentially the same insight—more specific forms blocking less specific forms—the implementation, however, is strikingly different.

37.

		Intransitive	Transitive
a)	i.	-ar- (ag-ar-u <i>rise</i> )	-e- (ag-e-ru <i>raise</i> )
	ii.	-re- (hazu-re-ru <i>come off</i> )	-s- (hasu-s-u <i>take off</i> )
	iii.	-ri- (ta-ri-ru <i>suffice</i> )	-s- (ta-s-u <i>supplement</i> )
	iv.	-e- (kog-e-ru <i>become scorched</i> )	-as- (kog-as-u <i>scorch</i> )
	v.	-i- (ok-i-ru <i>get up</i> (intr))	-os- (ok-os-u <i>get up</i> (tr))
b)	i.	-∅- (nar-∅-u <i>ring</i> (intr))	-as- (nar-as-u <i>ring</i> (tr))
	ii.	-∅- (ak-∅-u <i>open</i> (intr))	-e- (ak-e-ru <i>open</i> (tr))
c)	i.	-e- (kir-e-ru <i>be cut</i> )	-∅- (kir-∅-u <i>cut</i> )
	ii.	-ar- (matag-ar-u <i>sit astride</i> )	-∅- (matag-∅-u <i>straddle</i> )

38. a) BECOME +CAUSE → /-e-/ in env. [(a)(i)]  
 b) BECOME +CAUSE → /∅/ in env. (c)(i)  
 c) CAUSE → /-e-/ in env. (b)(ii)+BECOME  
 d) CAUSE → /-as-/ in env. (b)(i)  
 e) CAUSE → /-(s)ase-, -(s)as-/ elsewhere

The crucial point here is that by assuming Late Insertion, Miyagawa is able to avoid positing a whole separate level of lexical structure to account for the blocking effect produced by non-*sase* realizations of CAUSE on the causative morpheme. Further, he is able to assume that the realization of the syntactic causative and the lexical causative are taken care of by the same Vocabulary Item—the elsewhere item, 38e) above. On this analysis, the syntactic *-sase-* is a CAUSE head, as is its lexical counterpart. Miyagawa treats it as taking a clausal complement. For Miyagawa, clauses do not participate in the type of class-membership phenomena that verbal stems do, so syntactic *-sase-* will never have allomorphs of the type found in lexical causatives.

I adopt a version of this analysis here. Miyagawa's approach focuses on the status of these lexical causatives as evidence for Late Insertion; I would like to shift the emphasis a little bit and argue that the lexical/syntactic distinction here is an argument for the view of the “VP” outlined above.

### 3.2.2.3 *Lexical causatives: realizing CAUSE*

A crucial fact about the intransitive/transitive distinction in the lexical causative paradigms (formed with *-sase-* or otherwise) is that the intransitive member of the pair is *always* unaccusative/stative. Particularly for lexical causatives formed from *-sase-*, this observation is not always noted. In Miyagawa (1989), for instance, *-sase-* is referred to as “transitivizer”, adding an argument to a verb or a clause. Crucially, however, in the lexical causative, this verb or clause prior to transitivization must be of the unaccusative type. Unergative intransitives do not occur in the lists in Jacobsen, nor in the intransitive member of the pairs of *-sase-* lexical causatives in Miyagawa (1989). That is, *lexical causatives are always formed on stems lacking an external argument.*

We can test whether or not a lexical interpretation is possible for a *V+sase* combination where the verb has an external argument. On a PDS approach to lexical causatives, one might expect that intransitive unergatives could have *-sase-* affixed to them to form a lexical causative, since their transitive slot in PDS is not filled. This is never the case. When *-sase-* is added to an unergative verb, only the analytic meaning can result; an idiomatic, non-compositional, lexical meaning is never available. An example of this can be seen in 39) below. Using Miyagawa's test for underlying unaccusativity (the ability to float a numeral quantifier in object position—see discussion in section 3.1.3 above), we can see in 39a) that *waraw*'laugh' is unergative, as a NQ cannot occur in an objective base position. In 39b) we see that an “adversity causative”<sup>26</sup> interpretation of *waraw-sase-ta* is unavailable. Oehrle and Nishio (1981) argue that the adversity causative interpretation is only possible for lexical causatives; hence it can be used to test for analytic vs. lexical causatives:

---

<sup>26</sup>This type of reading is suspiciously similar to “experiencer have” discussed in section 3.2.6.2 below; these sentences entail that the event that is a complement to *sase* had an adverse effect on the matrix subject.

39. a) \***Gakusei-ga** [VP tosyokan-de 2-ri waraw-sita]  
*students-N library-at 2-CL laugh-did*  
 “Two students laughed at the library”
- b) Doroboo-ga Yakko-o waraw-ase-ta  
*a thief-N Yakko-A laugh-cause-Pst*  
 “A thief made Yakko laugh.”  
 \*”A thief had Yakko laugh on him” (e.g., revealing his presence).

Lexical causatives, then, no matter how they are formed, act to add an external argument to the I-syntactic representation of a verb. Crucially, they *cannot* be formed if there already is an external argument in the I-syntactic representation—that is, if there already is a CAUSE morpheme in the I-syntactic representation—no matter what the surface valency of the verb.

This fact parallels the restriction on reduplication of causative meanings implied by the “blocking” effect above. When a “double causative” appears (*V-sase-sase*) the interpretation of the outer *-sase-* is necessarily analytic—a lexical causative can never be formed on a pre-existing lexical causative<sup>27</sup>. This is true of lexical causatives formed via affixation of any of the causativizing morphemes seen in 37) above.

What seems to be the case, then, is that the lexical causative affix is the morphological realization of a CAUSE Event head—that is, of a Event head that selects an external argument. There is no sense, then, in which a lexical causative is a “transitivizing” affix that attaches to a pre-existing intransitive “verb”: lexical causatives are like the monomorphemic agentive English verbs like *kill*, which contain CAUSE in their I-syntactic

---

<sup>27</sup>We still have no account of the restriction on stacking of *analytic* causatives. No multiple *V+sase+sase+sase+sase...* combinations are possible, where *sase* is receiving the analytic interpretation. This stacking is perfectly possible with English “make”: “Calvin made Susie make Hobbes make Rosalyn...” As things stand, any Event head should be a legitimate complement for *sase*, even one headed by another analytic *sase*. See Kuroda (1993) for discussion. Bobaljik (p.c.) suggests that this restriction could be morphological, rather than syntactic, comparable to the restriction on more than one *-s/* affix in English: \**the boys’s books*. Even if the syntax allows a possible configuration, the morphology can block iterations of “types” of affixes. A suggestion of Kuroda (1993) might provide some support for this; it is possible, he claims, that a single *sase* can have the meaning of a “double” *sase*, just as in “the boys’ books” the single *-s* morpheme has both plural and possessive functions. Again, see Kuroda (1993) for discussion.

structure<sup>28</sup>. Presumably, it should be possible to have an Event head which does *not* select an external argument. The corresponding “detransitivizing” affix that appears on many of the intransitive counterparts to lexical causatives (see the “intransitive” column in 37)) is similarly a realization of a non-CAUSE Event head; what we will call “BE”—a Event head that does not select an external argument. As a visual aid, here, I indicate the l-syntax structures of *ag-ar-u* ‘rise’ and *ag-e-ru* ‘raise’.

40.

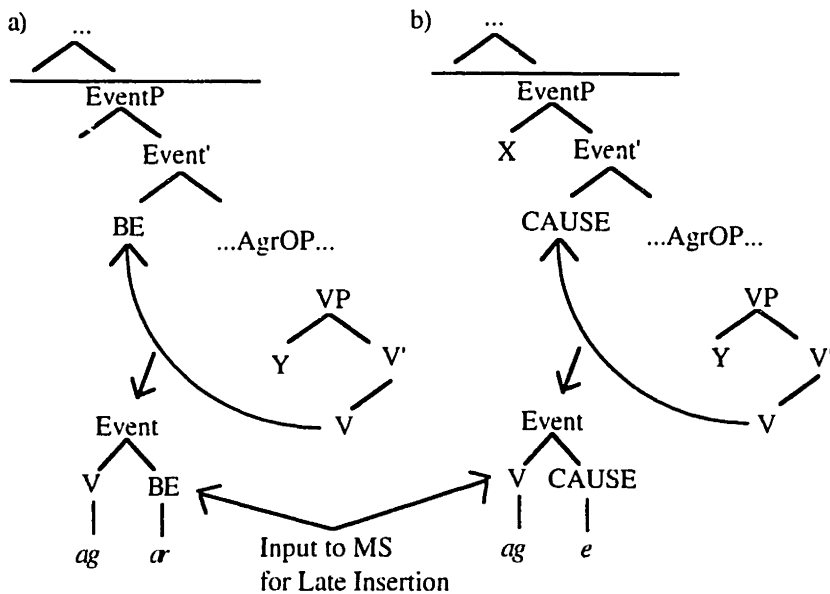

Thus, we provide additional motivation for adopting the view that external arguments are introduced by a head, with semantic content, rather than assuming with, e.g.

<sup>28</sup>If, as proposed here, all unergatives have already a CAUSE head in their EventP (as they have external arguments) we have an account of the impossibility of forming a zero-derived causative on an unergative in English (as pointed out to me by Jonathan Bobaljik):

- i) \*We laughed the child (from *the child laughed*)

This is bad for the same reason that lexical causatives cannot be “stacked” in Japanese: the presence of the CAUSE morpheme in the representation marks the delimitation of an EventP; in order to add a CAUSE morpheme to the structure of the verb “laugh” a new EventP, and hence a new domain of l-syntax, must be introduced. Contrast this with

- ii) We jumped the horse (from *the horse jumped*)

Verbs of motion and location can be optionally unaccusative, with the moving thing acting as a Theme (this allows the famous “Locative Inversion” construction: *Over the fence jumped the horse*, cf. Bresnan (1992)). When a verb of motion is unaccusative, it has a BE Event head. When that event head is realized as a CAUSE, an external argument is introduced, giving the zero-derived causative form in ii). (Verbs of motion can also be realized as unergative, of course, with the underlying structure something like iii), like any other unergative (see the discussion in section 3.2.4.2)).

- iii) [<sub>Event</sub> the horse [ CAUSE... [<sub>VP</sub> a jump]

Hale and Keyser (1993) that external arguments are merely the result of adjunction to some type of predicative structure. Note that on such a view, the difference between *ag-ar-u* and *ag-e-ru* would be the presence or absence of an adjoined external argument. There would then be no explanation for the presence of the additional morphology on the intransitive *ag-ar-u*. One would expect, perhaps, the occurrence of ill-formed bare stem *\*ag-u*, given that *-e-* can appear as a causativizing morpheme on stems whose intransitive counterpart requires no extra morphology—that is, can be bare (compare *ak-u* 'open(intr)' and *ak-e-ru* 'open(tr)'). Given that *-e-* alternates with a null BE morpheme (in *aku* "open"), it cannot be the case that it must be replaced with *-ar-* in intransitive "raise". Further, it cannot be the case that the morphology is purely "thematic", present to ensure well-formedness when no derivational morphology is attached to the root *ag-*. If that were the case, one would expect that the addition of, for instance, an analytic causative to the intransitive form would satisfy the well-formedness requirement, and that the *-ar-* morphology should drop off. This does not happen: in order to express an analytic causative of the intransitive, *-sase-* must be affixed to the stem *ag-ar* rather than to the root *ag-*. This can be seen in 41) below:

41.   Yakko-ga   Wakko-o   butai-ni   agar-ase-ta/\*ag-ase-ta  
           *Yakko-N   Wakko-A   stage-on   rise-Cause-Past*  
           "Yakko made Wakko rise onto the stage" (e.g. by magic).

Now, take the structure of the syntactic/analytic causative. It is analytic, hence is not formed within the I-syntax. Further, it denotes two separate events, an event of causing and the resulting event. It can have two external arguments (matrix and embedded), each of which can antecede a subject-oriented reflexive. Its complement bears no tense morphology whatever. Further, we would like it to be eligible for the CAUSE Vocabulary Item *-sase-* in 38e) above; hence, it must be realized as a pure CAUSE terminal node in the syntax. I would thus like to suggest that the syntactic/analytic causative is an EventP which takes another EventP as its complement<sup>29</sup>. The structure would be that in 42) below:

---

<sup>29</sup>See Chapter 5 for extensive discussion of the syntactic causative.

42.

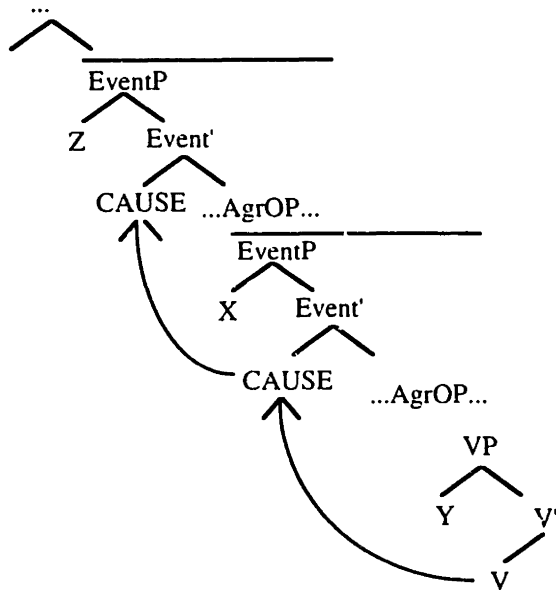

Note that the top CAUSE head will be a separate domain of I-syntax from the lower VP, and hence no class-conditioned allomorphy will ever appear in the analytic causative, which will always be realized as the Elsewhere causative, *-sase-*.

### 3.2.2.3.1 More evidence for Late Insertion

In addition to the inherent elegance of treating the insertion of *-sase-* as an example of the default morpheme on a par with other instances of morphological realization, the above argument from unergative verbs provides strong evidence for a Late Insertion approach to lexical realization. Consider how a PDS account might attempt to prevent the formation of a lexical causative on an unergative root. The most obvious way is to assume that the unergative root already fills a transitive slot in the PDS representation—that is, that it is represented as transitive at PDS, in line with (for instance ) Hale and Keyser's (1991) proposal that all unergatives are underlyingly transitive. On such an account, *waraw-* “laugh” would be represented as the transitive “do a laugh” in PDS, hence blocking the addition of a transitivizing *-(s)ase-*:



43.

Transitive
DO + <i>waraw</i>
* <i>waraw-ase</i>

A paradox arises, however, on such an account. The formation of the intransitive verb *waraw* from DO+”laugh” will have to occur after PDS, to ensure that the blocking of lexical *waraw-ase* takes place at PDS, but the formation of lexical causatives like *koyas* from *koe +as* will have to take place before PDS, again to ensure blocking of *koe-sase* at PDS. A PDS account, then, requires word-formation processes to occur both before and after PDS. On a Late Insertion account, however, no such problem arises; both *waraw* and *koyas* will be represented as having a CAUSE Event head in the syntax, which will be spelled out according to the rule block for spelling out CAUSE and blocking the formation of *waraw-sase* and *koe-sase* in each case.

### 3.2.3 *EventP as a delimiter: why non-compositional interpretation?*

At this point, I would like to remind the reader of Kratzer's original motivation for separating the subject from the rest of the VP. Her argument essentially was that objects and verbs could receive non-compositional interpretations, but that subjects and verbs never could, to the exclusion of the object. The semantic rule she proposes to combine the embedded VP with her Voice head was non-compositional—there was no sense in which the Voice head was a function that took the lower VP as an argument, or vice versa. I would like to suggest that this accounts for the word-level intuition associated with an EventP; the EventP is the domain of l-syntax because it is the point at which regular Fregean composition ceases to apply.

### 3.2.4 *Properties of EventP*

We have so far implied that any “verb” is made up of some phrase (labeled “BaseP” above) in combination with an Event head, CAUSE or BE (external argument-selecting or not-external-argument-selecting). There are two possibilities for the status of BaseP. The first is that it contains the basic verb, either a bound stem that must have CAUSE attached to it (like *kill*) or a stem that allows either CAUSE or BE to attach to it (like *open*). This is essentially the approach taken in Pesetsky (1994). The second is that there are no “basic verbal stems”: “verbs” are the result of combining a basic categorial element (in the sense of Hale and Keyser, explained below) with an Event head. I will adopt the latter approach here, to maintain Hale and Keyser’s account of the paucity of  $\theta$ -roles, while glossing over problems posed by object experiencer verbs like *annoy*, treated in depth by Pesetsky (1994).

#### 3.2.4.1 “Primitives”: *A, N, P*

On such an approach, there are a few primitives that can combine with the Event head to form a verb. In an ideal world, these primitives should be so characterized that there is one combination that represents each significant class of verbs. Then, as far as the syntax is concerned, the difference between two verbs which are members of the same class will be the same as the difference between “cat” and “dog”—that is, non-existent. Late Insertion will take care of specifying which of the many possible members of a given verb class a given combination of Event+Base represents. For example, the difference between “give” and “show” would perhaps not be encoded in the syntax.

The “primitives” which are candidates for BaseP are structurally defined. Hale (1995) argues that there are four basic structures, which tend to have a canonical realization

as the four basic categories N, P, A, V cross-linguistically, although the realization is far from fixed. As I am arguing here that the notion of a V is derivative, we are reduced to three basic categories: N, P, and A. The most restricted theory of verb types would maintain that there should be only as many as can be represented by combining one or two instances of each of these categories with an Event head.

Take a given  $X^\circ$ , call it Base<sup>30</sup>. It can project a bare BaseP, a BaseP with a complement, or a BaseP with both a complement and a specifier. This gives three possible configurations for BaseP which correspond to the three possible categories, illustrated in 44) below<sup>31</sup>:

44.

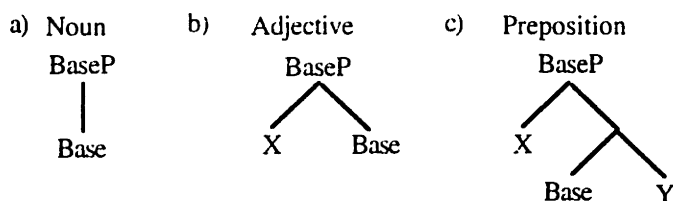

Nouns are sufficient unto themselves; they do not (in Hale (1995)’s terms) “conceptually force” a relation with any other element.<sup>32</sup> Adjectives must be in a relation with one other element; they must attribute a property to something. Prepositions<sup>33</sup> express a relation between two elements. The structures above can be thought of as Base taking no arguments, one argument, or two arguments<sup>34</sup>, which correspond to the basic categorial distinctions above.

<sup>30</sup>This head corresponds most closely to the core of the notion “verb” and in diagrams above its projection has been notated VP; I term it BaseP here, however, to emphasize the differences between this projection and what is commonly thought of as a verb, with its baggage of temporal and action-oriented connotations. Thanks to Norvin Richards for suggesting the terminology.

<sup>31</sup>N.B. in these structures there is no inner V head like that proposed in Hale and Keyser; at the moment I see no reason to have such a head.

<sup>32</sup>However, they can participate in predication relations: see Carnie (1995) for discussion.

<sup>33</sup>Although I will use “preposition” to refer to the relational “Base” element, it is not to be thought of as simply an empty preposition in the canonical sense, as it cannot case-mark its complement. Complements of relational “Bases” still need to be case-marked in some way, usually via structural case-checking in an AgrIOP, as outlined for double object constructions above.

<sup>34</sup>Restricting the structure to one specifier may seem arbitrary, but it is not clear to me what a Base relating two or more elements to a third element would mean, or that it is necessary, given the my understanding of the facts.

### 3.2.4.2 The “syntax” of *l*-syntax

Hale and Keyser (1993) convincingly demonstrate that the formation of denominal and deadjectival verbs is governed by the types of structures seen above, in combination with certain well-motivated syntactic laws—in particular, the Head Movement Constraint (Travis (1984), Baker (1988)). The bare Base head (of type “noun”) can incorporate via head-to-head movement into the next closest head up and thence into the Event head, giving an unergative verb. “Prepositional” Base heads can incorporate, resulting in, e.g., *give* in its double object usage. “Adjectival” Base head can incorporate, resulting in, e.g., verbal *thin* (“the cook thinned the gravy/the gravy thinned”).

Further, following a suggestion of Baker, Hale and Keyser argue that there is a syntactic distinction between specifiers and complements of Base which restricts the possible class of incorporated forms, resulting in the correct exclusion of a non-occurring class of denominal verbs. They argue that elements properly governed by Base can incorporate into it and move along with it. This is restricted to the class of complements of Base: the complement to a “prepositional” or “adjectival” base, as in b) or c). If the complement of a preposition incorporates (44c)), a denominal verb like, e.g., *saddle* is produced—the underlying structure of “Opus saddled Rosebud” is represented in 45).

45.

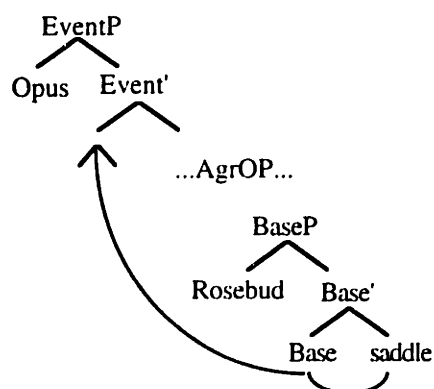

Now, imagine a structure where *saddle* is in the specifier of BaseP, rather than its complement (where *Rosebud* is in 45)). Incorporation of this NP is prevented by the ECP, as the BaseP will be a barrier to extraction, given that Base is the closest governor. Elements in specifier position (what Hale and Keyser call an “internal subject”) will not be able to incorporate, thus ruling out the non-occurring class of possible verbs like “\*churched the money”. This demonstration that I-syntax is subject to structural constraints like the ECP, mirroring the identical restriction in clausal syntax, constitutes one of the major results of Hale and Keyser’s investigation.

When the Base head without a complement or a specifier (structurally, an N in English) in 44a) incorporates into Event, the result is an unergative verb like “dance” or “sing”. Hale and Keyser note that there are languages where this incorporation is morphologically reflected. Either the CAUSE head is represented by a light verb, and no incorporation takes place (as in, e.g., Basque<sup>35</sup>) or overt morphology appears on the verb to indicate that incorporation has taken place (as in, e.g., Jemez<sup>36</sup>). Note that Hale and Keyser assume that the light verb in these structures is not like our Event head, here, which when selecting an external argument is realized as CAUSE, but is more like a light verb “do”. On our account no separate notion of a light “do” is necessary. Given the notion that verbs formed in the I-syntax denote a single event, CAUSE+jig really entails the same meaning as “do a jig.” The required intuition is the same as that governing the difference between “direct causation” and “indirect causation” which results in the difference between “kill” and “cause to die” discussed above—that is, the external argument being the CAUSER of an event, or the CAUSER of an event that results in another event. As

---

<sup>35</sup>Some Basque examples can be seen below, where the nominal element is not incorporated into the verb “do”:

- |    |                |                |
|----|----------------|----------------|
| i) | sæ’-a          | zæi’-a         |
|    | <i>work-do</i> | <i>song-do</i> |
|    | “work”         | “sing”         |

<sup>36</sup>A Jemez example is below:

- |    |                 |
|----|-----------------|
| i) | se-ʔa           |
|    | word-do “speak” |

discussed in Pesetsky (1994), “Calvin kisses Rosalyn,” doesn't really mean “Calvin causes Rosalyn to be kissed.” The latter sentence can denote a situation in which Calvin himself doesn't have to be kissing Rosalyn, but he could instigate, for instance, an appearance of her boyfriend which inevitably results in a kiss. The former sentence, however, entails that Calvin himself is kissing Rosalyn. Similarly, “John danced”, which on the analysis here is formed of “John CAUSE+dance”, doesn't really mean “John caused a dance”—the implication again is that there was a single event of dancing which John was the instigator of, and hence John himself is the one who dances.

On a story like Hale and Keyser's, then, it is possible to reduce denominal verbs like “saddle” and “dance”, and deadjectival verbs like “thin” and “clear”, to a notion of “Event+A”, or “Event+N”. What about cases of Event+P? Is “Opus gave Ronald-Ann a book” really composed of something like “Opus CAUSE Ronald-Ann HAVE<sup>37</sup> a book”? Below, I present evidence that this is indeed the correct way to think of double object constructions.

### 3.2.5 “Give” = CAUSE x HAVE y

The question that I intend to explore in this section is simply expressed. There are languages that lack possessive “have”—they do not express possession in the “owner has ownee” sense that we are familiar with from English. If the correct analysis of a double object construction like “Opus gave Ronald-Ann a book” is to break it down into something like “Opus CAUSED Ronald-Ann HAVE a book”, it might be the case that we predict that languages that do not have possessive “have” should not have a double object construction. We cannot approach the prediction quite this straightforwardly, however, as the notion of

---

<sup>37</sup>As HAVE on my conception here is prepositional a perhaps more mnemonic way to refer to this item might be as the preposition “with”; the verb “have” on that account would be “CAUSE+with”; however, the null preposition is sufficiently different from the overt one in terms of case properties that I feel it is important to distinguish between the two.

“have” I refer to here is not necessarily as simple as the monomorphemic verb “have” in English. When I say a language has possessive “have” here, I mean particularly that the lowest position of the possessor c-commands the lowest position of the possessee in a sentence expressing possession, rather than the other way around. The expression of this relation can vary cross-linguistically, and languages that do not have possessive “have” can appear to be similar to the languages that do; the reader should bear this crucial distinction in mind when considering the data below.

### 3.2.5.1      *The “preposition” HAVE*

Verbs<sup>38</sup> like “give” or “show” in English can realize their arguments in two possible ways, which I will refer to below as “double complement” and “double object” constructions. In the former, the “Goal” argument is realized as the complement of an overt preposition; in the latter, the “Goal” argument is realized in a direct object position, subject to the same Adjacency effects as other direct objects (as seen in section 3.2.2 above). Examples of these are in 45a) and b) respectively:

45.    a) Opus gave a book to Ronald-Ann.  
      b) Opus gave Ronald-Ann a book.

Much ink has been spilled over this alternation. On a view of the lexicon where *give* is a verb that selects two arguments, a Goal (*Ronald-Ann*, above) and a Theme (*a book*, above), this variation in realization of the two internal arguments causes much consternation. The Universal Theta Alignment Hypothesis (UTAH) of Baker (1988) holds that thematic structure of a verb is directly reflected in its syntactic projection. Such a condition entails either i), that one of 45a) or b) must be derived from the other in the syntax (if the verb “give” has the same theta-roles in both cases) ii), that different theta-

---

<sup>38</sup>I will continue to use terminology like “verb” and “argument” to facilitate exposition; the reader is warned, however, that I am using these in a purely informal sense, as I am arguing for a view of the syntax in which these notions play no basic role, and are not primitives.

roles are being assigned in these examples, or iii) that both are derived from a third, underlying structure which never surfaces at Spell-Out.

The former approach is exemplified by Larson (1988), who analyses 45b) as a “passive” of 45a). Similar approaches have been proposed in the Relational Grammar literature, involving 3->2 promotion.

Given that here we are attempting to motivate a view of the lexicon according to which verbs are a derived notion, we are not confined by principles like UTAH in quite the same way, although the analysis proposed here is essentially of type ii) above. Agentive double object and double complement verbs must be derived from an EventP with an external argument and a prepositional BaseP complement, as three arguments are introduced in these structures. Hale and Keyser propose that in double complement structures, this prepositional element is realized overtly, as *to*.<sup>39</sup> In double object structures, on the other hand, the prepositional element is null (like Pesetsky (1994)'s G head), possibly incorporated into the Event head. This type of analysis entails that rather than deriving double complement structures from a “more basic” double object structure or vice-versa, double complement and double object structures are both base-generated, as argued in, e.g. Marantz (1993), and that different prepositions or relations (different “Bases”) are involved in the complements to each (as in Pesetsky (1994). The preposition in the first case expresses a relation of the Theme being in the same location as the Goal, while the preposition in the double object case expresses a relation of the Goal having the Theme. I will notate this latter prepositional/relational element as HAVE for now; the reader is cautioned to remember, however, that it is *relational*, not verbal. A passivization approach to the double complement construction is therefore not possible; we are not

---

<sup>39</sup>Marantz (p.c.) contends that verbs like “give” can be spellouts of heads in the environment of other heads, and actual incorporation or merger may not take place. This seems to be the prediction in this case, as in the double complement construction the overt preposition “to” never gets to the Event head, which is spelled out as “give”.



dealing with any element that can be passivized<sup>40</sup>. Rather, the preposition realized as *to* is a completely different element, which I will notate as LOC<sup>41</sup>. The double complement construction, then will be abstractly represented as “CAUSE Y LOC X”.

### 3.2.5.2 “Have” = BE + HAVE

The notion of the double object construction decomposing into the basic elements “CAUSE X HAVE Y” is intuitively a plausible one<sup>42</sup>. *Prima facie*, however, there seems to be no possible evidence for it, except for the general arguments for the decomposition approach outlined by Hale and Keyser. A concept advanced by Guéron (1986) and later adopted in Freeze (1992), however, suggests a possible source of evidence.

Freeze (1992) suggests, on the basis of evidence from many languages, that verbal “have” is derived from BE plus a prepositional element. He notes that the notion of possession in many diverse languages is expressed by using the existential BE plus some prepositional marking on the possessor. This is true in Hebrew, Japanese, Irish, Tagalog, Hindi, Russian, Finnish, Yucatec, Chamorro, Palauan, and others. Verbal “have”, he argues, is derived from the same basic relation, although it is realized on the surface in some Indo-European languages (Germanic and Romance, e.g.) as a separate verb. “Have” as an auxiliary is essentially the same element as auxiliary “be”, it merely incorporates a prepositional element. Other proponents of this approach include Kayne (1993), Nash (1994) and Mahajan (1994).

---

<sup>40</sup>On this approach, passives can only be formed on CAUSE Event heads; see discussion in Chapter 5 for further speculation.

<sup>41</sup>The fact that the Spell-Out of both CAUSE+HAVE and CAUSE+LOC is “give” might suggest that in fact “give” is merely a Spell-Out of “CAUSE” rather than an incorporated CAUSE+P form; otherwise, accidental homophony would need to be posited for the fact that the two incorporations result in the same surface form.

<sup>42</sup>It is suggested, for instance, as part of account of particle constructions in Icelandic in Collins and Thráinsson (1993).

In the framework here, this intuition is easily expressed. Verbal *have* is the Spell-Out of a non-external-argument selecting Event head (we will notate this head as BE, as above), plus the preposition HAVE posited for the double object construction above—essentially, an agentless *give*. So far, then, we have the structures listed in 46) below:

46. a) BE+HAVE --> *have*  
b) CAUSE + HAVE --> *give* (double object)  
c) CAUSE + LOC --> *give .. to* (double complement).

Note that the existence of these two possible PP complements predicts the existence of another type of construction corresponding to 46a) above, that is, one where the Event head does not project an external argument and the complement is the LOC PP, that is, where the verb is “BE + LOC”. This type does, of course, exist, and is realized as the locative construction:

47. A book is on the shelf.

The structures for *have*, the locative construction, *give* (double object) and *give* (double complement) can be seen in 48a), b), c) and d) respectively<sup>43</sup>:

---

<sup>43</sup>Again, note that for me it is essential that the HAVE preposition cannot assign case to its complement *in situ*, while LOC can. This will force the movement of the complement of HAVE to an Agr projection for case-checking purposes, deriving the Adjacency effects seen in the previous chapter in double object constructions. It might be the case that an overtly realized preposition can assign case, while a null one never can. See also the discussion of prepositional vs. quirky case in Chapter 6.

48.

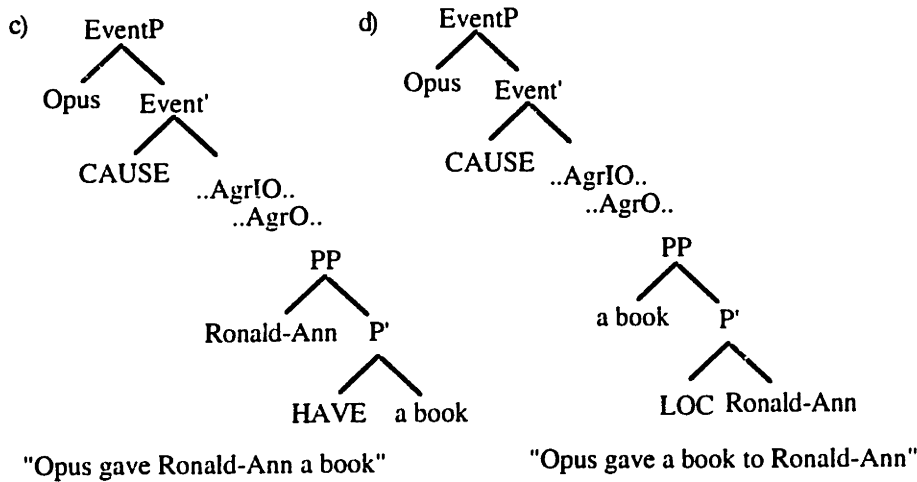
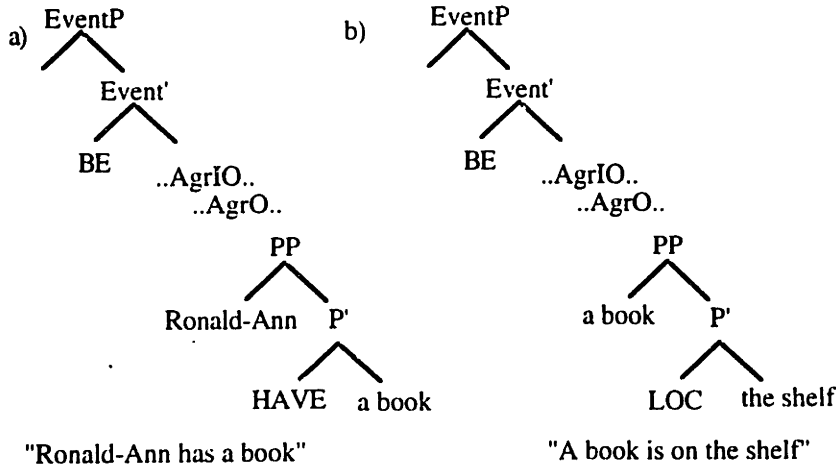

3.2.5.3                      *Existentials, possessives and locatives: Freeze (1992)*

Freeze (1992) notes that in many languages, expressions of possession, location and existence all appear very similar. The existential in Hindi, for instance, appears to be in all respects except argument order, exactly like the locative. The arguments are reversed in order (Freeze (1992):555):

49.    a)    Locative  
          māī   hindustaan-mēē    thaa  
          I       India-in               BE.sg.msc.pst  
          "I was in India"  
          Theme                      Location                      V

- b) Existential  
 kamree-mēē aadmī hai  
*room-in man BE.3sg.msc.pres*  
 “In the room is a man” (“There is a man in the room”)  
**Location Theme V**

Similar facts are presented from Chamorro and Finnish. Now, consider the Hindi possessive construction:

50. Possessive  
 larkee-kee paas katta hai  
*Boy-Obl-G near dog BE.3sg.msc.pres*  
 “The boy has a dog. (Lit, “Near the boy is a dog”).  
**Location/Possessor Theme V**

Freeze contends that the possessive construction *is* the existential construction, with a human location in subject position being the possessor. I will accept this generalization. However, Freeze maintains that the Locative and Existential/Possessive are derived from the same underlying structure, in 51). below:

51.

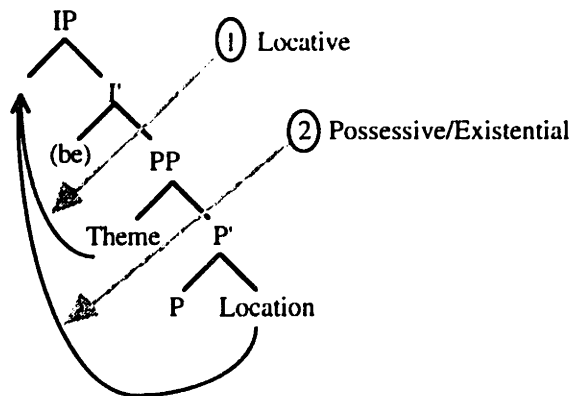

The locative construction surfaces when the Theme argument moves to the subject position in Spec-IP (movement #1 above), while the existential/possessive construction occurs when the Location argument moves to subject position (movement #2). He suggests that the occurrence of movement is controlled by definiteness markers on the theme nominal: if the theme is definite, it moves out of the VP to the Spec-IP position (#1), giving the locative construction in 49a). If the theme is indefinite, it remains within the VP, while the location argument moves to Spec-IP (#2), giving the existential, as in 49b). This, he

claims, accounts for a cross-linguistic tendency for the object of the existential to be indefinite.

### 3.2.5.4 *Definiteness vs. HAVE*

Freeze's analysis contains some interesting insights, but his account of the derivation of the locative vs. existential/possessive construction in terms of definiteness seems flawed. First, although there is a tendency for the theme of an existential construction to be indefinite (\*There is the man in the room), there is no such restriction on the theme in a possessive construction:

52. a) Calvin has the stuffed tiger.  
**Location/Possessor**      **V**      **Theme**
- b) John-ga/ni      zibun-no uti-ga      aru      (Japanese)  
*John-N/D      self-gen house-N      exist*  
 "John has his house"  
**Location/Possessor**      **Theme**      **V**

Since Freeze wishes to unite the possessive and the existential, deriving them from the same underlying structure via the same movements, it seems likely that the definiteness requirement is not what is crucial in the derivation of the possessive/existential construction, although the interaction of the semantics of existential assertion with definiteness could produce an apparent correlation. Freeze's assertion that the choice between the existential/possessive and locative constructions depends crucially on definiteness seems untenable. Instead, an account like that proposed here suggests itself, under which the difference in location/locatum ordering between the two constructions is base-generated according to the identity of the embedded preposition. (The locative structure is seen in 48b) above, the existential/possessive construction in 48a)).

Given that the definiteness effect does not manifest itself in possessive structures, even in languages which exhibit the definiteness effect in existentials (like English), accounting for cross-linguistic variation by suggesting possible variation in the strength of

the definiteness effect is less than attractive. Freeze points out that in Scots Gaelic (a VSO language), there is no variation in word order between the locative and existential/possessive constructions. The paradigm is seen in 53) below (I include an example of a definite Theme in the *have* construction in 53d)):

53. Scots Gaelic

Locative

a) Tha a' mhin anns a' phoit.  
*BE the oatmeal in the pot*  
 "The oatmeal is in the pot."  
**V Theme Location**

Existential

b) Tha min anns a' phoit  
*BE oatmeal in the pot*  
 "There is oatmeal in the pot"  
**V Theme Location**

Possessive

c) Tha peann aig Màiri  
*BE pen at Mary*  
 "Mary has a pen".  
**V Theme Location/Possessor**

d) Tha an peann aig Màiri  
*BE the pen at Mary*  
 "Mary has the pen"

Freeze proposes to account for this puzzling lack of variation in word order between the two types of construction by relaxing the definiteness effect for Scots Gaelic. On our account, this lack of word-order variation has a more straightforward source: Scots Gaelic simply *lacks* the possessive/existential prepositional element HAVE in 48a) above. Instead, it uses the locative construction throughout to indicate possession, existence, and location; the theme argument always appears in subject position, reflecting its base-generation in the specifier of the PP headed by LOC, while the location/possessor is always realized as an objective/oblique PP. This is the sense in which a language can lack *have* that I wish to pursue here. I will consider a pattern like that in 53) above as a possible diagnostic of this lack: if the order of the Location/Possessor and Theme arguments in the possessive/existential and locative constructions is the same, the language lacks the

prepositional/relational element HAVE that enables the possessive/existential construction to have its arguments base-generated in the opposite order from those in the locative construction.

Let us reiterate the prediction under investigation: if a language lacks the HAVE preposition, in which the possessor c-commands the possessee, and if double-object *give* (45b) is correctly represented in the syntax as CAUSE X HAVE Y, then languages that lack HAVE should lack double-object *give*.<sup>44</sup>

### 3.2.5.5 *HAVE-not languages*

#### 3.2.5.5.1 Irish

To begin, I wish to consider the case of Irish<sup>45</sup>. The locative, existential and possessive constructions pattern together across the paradigm, as is the case of Scots Gaelic above. The paradigm is seen in 54) below:

---

<sup>44</sup>Note that the difference between the two constructions on this proposal resides exclusively in the properties of the preposition - that is, the prepositional element has two different realizations that result in the different ordering. Another possible approach would be to assume that the prepositional element in orderings was the same, and that the difference in the position of base-generation is purely a reflection of semantic differences between the two constructions. Marantz (1993) makes a proposal along these lines for Bantu double-object constructions, asserting that the ordering reflects the affectedness of the indirect object. The data presented here pose a problem for this type of approach, however. On the approach adopted here, cross-linguistic variation in word order possibilities are accounted for in terms of the presence or absence of an (easily learnable) given syntactic element. An approach like that of Marantz, on the other hand, would entail either that languages like Scots Gaelic or Irish lack a *semantic* notion of "affected Goal", which is surely not reasonable, or that the mapping principles for "affected Goal" can vary from language to language.

It is possible that the two accounts can coexist, however. Marantz discusses evidence from Bantu benefactive double object constructions, while the elements discussed here are locative/possessor double object constructions. There is evidence, as noted by de Hackbeil (1989), that the event structure of double object benefactives differs from that of locative/possessor-type; specifically, benefactives involve two events, while these involve a single event. Marantz captures this by positing an embedded VP headed by an Applicative morpheme, which on our account would be represented by an embedded EventP. The mechanics of his proposal would then translate straightforwardly.

<sup>45</sup>Many thanks to Andrew Carnie for data and discussion of the Irish facts below.

54. Locative  
 a) Tá an mhin sa phota.  
*BE the (oat)meal in.the pot*  
 "The oatmeal is in the pot."  
**V Theme Location**

Existential  
 b) Tá min sa phota  
*BE oatmeal in.the pot*  
 "There is oatmeal in the pot"  
**V Theme Location**

Possessive  
 c) Tá peann ag Máire  
*BE pen at Mary*  
 "Mary has a pen".  
**V Theme Location**

d) Tá an peann ag Máire  
*BE the pen at Mary*  
 "Mary has the pen"

Irish is therefore a HAVEless language in the sense we are interested in. Indeed, Noonan (1992) has proposed a productive analysis of psych verbs and statives in Irish arguing for exactly this conclusion. I refer the reader to the discussion of her work in chapter 5.

Crucially, there is nothing resembling a double object construction with Irish ditransitive verbs. The Locative/Goal NP must always appear after the accusative-marked Theme direct object, as in 55a). The Locative NP cannot appear before the direct object (55b)<sup>46</sup> nor can it be marked with anything other than a prepositional element (55c).

55. a) Thug Míleó caisearbhán do Bhinlí W  
*Gave Milo dandelion to Binkley*  
 "Milo gave a dandelion to Binkley"

<sup>46</sup>There is a grammatical reading for this ordering, but as it requires a large NP it is clearly an instance of heavy NP shift. This order is also legitimate when the accusative-marked Theme is a pronoun, as in i) below:

i) Thúg Míleó do Bhinlí é  
*Gave Milo to Binkley it*  
 "Milo gave it to Binkley."

This is a result of a phenomenon of rightwards movement of pronominal elements in Irish, which occurs completely independently of syntactic constituency (Duffield (1994), Chung and McCloskey (1987), Carnie and Harley (forthcoming)).



- b) \*Thug Míleó do Binclí caisearbhán  
*Gave Milo to Binkely a dandelion*  
 “Milo gave to Binkley a dandelion”
- c) \*Thug Míleó caisearbhán Bhinclí/\*Thúg Míleó Bhinclí caisearbhán  
*Gave Milo dandelion Binkley/ Gave Milo Binkley dandelion*  
 “Milo gave Binkley a dandelion”

For Irish, at least, we can see that the lack of HAVE correlates with a lack of a double object construction.

### 3.2.5.5.2 Diné

This correlation holds in Diné (Navajo)<sup>47</sup> as well, although the situation is somewhat more complex. An instance of a typical possession construction is seen in 56) below<sup>48</sup>:

56. Diné ṭǫǫ' b-ee hółó  
*man horse he-with exists*  
 “The man has a horse” (Lit. “The man, a horse is with him”).  
 (Inverted element) **Theme Location V**

In Diné, ordering is strictly SOV. There is a wrinkle in the possessive construction in 56) above. The realization of the pronoun “he” in the oblique PP as *b-* indicates that inversion<sup>49</sup> has taken place. Inversion in this construction is usual, forced by the animacy hierarchy: when an object outranks a subject (which it usually will, as possessors tend to outrank possesseees) on the hierarchy it must be fronted to sentence-initial position (Hale (1973):302). Crucially, the non-inverted marking *y-* can never appear in the possessive construction, no matter what the order of the arguments:

<sup>47</sup>Many thanks to Ken Hale (p.c.) for data and discussion of this paradigm.

<sup>48</sup> The verb in this construction, *hółó*, is a combination of the verb “to be” plus a locative affix, translating approximately as *there is* or *there exists*, patterning again with the existential. The morpheme-by-morpheme breakdown is seen in i); morphophonological rules interact to produce the surface form.

i). hółó = h<sup>w</sup> -n -lí)  
 “areal” -Asp -be

The “areal” affix seems a likely candidate for the realization of our preposition/relation LOC, above.

<sup>49</sup>See Ura (forthcoming) for an analysis of Inversion constructions in Apachean languages, as well as Bantu and Tanoan.

57. a) \*diné t̥íí' y-ee hóló  
*man horse he-with exists*  
 "The man has a horse."
- b) \*t̥íí' shi-zhé'é y-ee hóló  
 \*horse my father he-with exists  
 "My father has a horse."

The inversion marking on the locative P, then, indicates that the possessor in the PP in these constructions must be below the possessed Theme subject. Diné, then, does not have the HAVE preposition that we are interested in.

As we expect, in Diné, the double object construction does not exist. The Location/Goal argument is always marked with a prepositional phrase, never with any kind of structural case. It can never appear in any type of direct object position—there is no dative shift in Diné. A prototypical example is seen in 58) below. When the *y-* morpheme appears in the indirect object position, indicating that no inversion has occurred, the direct object marker *yi* appears on the verb, agreeing with the Theme argument *rope*.

- 58). Shizhé'é sitsilí t̥ʔóót yi-chʔiʔ hada-y-íí-t-déél  
*My father my little brother rope him-to down-it-perf-tr-handle(LFO)*<sup>50</sup>  
 My father tossed the rope to my little brother

When *my little brother* is inverted to the front of the clause, the *b-* morpheme appears in the prepositional phrase.

59. Sitsilí shizhé'é t̥ʔóót bi-chʔiʔ hada-y-íí-t-déél  
*My little brother my father rope him-to down-it-perf-tr-handle(LFO)*  
 My father tossed the rope to my little brother

A construction where the Goal behaves as a direct object of the verb is impossible (60)—that is, where the agreement marker for the Goal argument shows up on the verb, like object agreement, rather than in a prepositional phrase as above:

60. \*Shizhé'é sitsilí t̥ʔóót hada-yi-y-íí-t-déél  
*My father my little brother rope down-him-it-perf-tr-handle(LFO)*  
 My father tossed my little brother the rope.

Diné thus behaves in accordance with our prediction, above.

---

<sup>50</sup>Long Flexible Object

### 3.2.5.5.3 Tagalog

Finally, I wish to consider the case of Tagalog, a language which Freeze maintains fits into his account of the split between locative constructions and possessive/existential constructions, which for us would entail that it is in fact a language with HAVE. Upon closer examination, however, it appears as if his analysis of Tagalog existentials is somewhat off track, and that Tagalog is a language without HAVE in the relevant sense.

Freeze's paradigm for Tagalog is seen in 61) below:

#### 61. Locative

a)    *na-*    *sa babae*    *ang*    *sanggol*  
       *BE*    *at woman*    *TOP*    *baby*  
       "The baby is with the woman."  
       **V**    **Location**    **Theme**

#### Existential

b)    *may*    *gera*    *sa*    *Europa*  
       *BE*    *war*    *in*    *Europe*  
       "In Europe is war." ("There is a war in Europe.")  
       **V**    **Theme**    **Location**

#### Possessive

c)    *may*    *relas*    *ang*    *nanay*  
       *BE*    *watch*    *TOP*    *Mom*  
       "Mom has a watch"  
       **V**    **Theme**    **Location/Possessor**

Freeze maintains that this reflects the general pattern he adduces: the existential patterns with the possessive (Theme Location order), while the arguments in the locative construction appear in the opposite order (Location Theme). There are problems with this analysis of the Tagalog facts, however. Note that the copula in the existential and possessive forms in 61b) and c) above differs from that in the locative construction in 61a)—the former is realized as *na*, while the latter is realized as *may*.<sup>51</sup>

<sup>51</sup>I use "copula" here in a loose sense, following Freeze; it is likely that these two elements are significantly different. See Carnie (1995).

Crucially, if the possessed thing is specific, the construction in 61c) above cannot be used. Instead, in these cases, the possessive patterns with the locative. This can be seen in 62) below (compare 61a)<sup>52</sup>:

62. Na- sa guro ang mansanas  
*BE at teacher TOP apple*  
 “The teacher has the apple” (Lit: “The apple is at the teacher”)  
**V Location/Possesor Theme**

In this instance, then, the possessive looks like the Scots Gaelic/Irish/Diné case, where possessives and locatives pattern together. This seems to be the significant case, as the realization of the copula here is the same as the realization in the locative in 61a) above (*na*). The pattern in 61c) above, where the predicate is realized as *may* is forced because the *na* construction must indicate topicalization. Topics must be specific, so when the possessed thing is non-specific as in Freeze’s 61c), the *na* construction cannot be used, forcing the use of the *may* construction. We have seen above that the Theme of an existential must also be non-specific/indefinite (possibly for semantic reasons), and hence the *may* construction is forced in the existential cases as well. The hypothesis is that if there was no specificity restriction on Topics, existentials and non-specific possessives would pattern with the locatives and specific possessives.

Tagalog, then, is another instance of a language where locatives and possessives pattern together, and is hence a language without prepositional HAVE in our sense. As predicted, it manifests nothing like the double object construction: the Goal/Location argument must always be marked with the locative marker *sa*. This is seen in 63)<sup>53</sup> below:

63. Nagbigay ng mansanas sa guro si Ikabod  
*AT-gave Obj apple LOCt teacher TOP Ikabod*  
 ‘Ikabod gave an apple to the teacher’

<sup>52</sup>Many thanks to Norvin Richards for a crash course on Tagalog, data and discussion in this section.

<sup>53</sup>In these and following Tagalog examples, the following abbreviations are used (of verbal morphology):

AT = Actor Topic  
 A = Actor  
 LT = Locative Topic  
 TT = Theme Topic

The Theme and the Goal cannot bear the same marker; 64) is wildly ungrammatical:

64. \*Nagbigay ng mansanas ng guro si Ikabod  
*AT-gave Obj apple Obj teacher TOP Ikabod*  
 'Ikabod gave the teacher an apple'

Evidence from topicalization morphology provides support for the unvarying status of the Goal/Locative argument as prepositional, never direct-object like. If the Goal is made the topic (65a)), topicalization morphology is used that is the same as that which marks topicalized locatives, (65b)) (involving the suffix *-an*):

65. a) Binigy-an ni Ikabod ng mansanas ang guro  
*LT-gave A Ikabod Obj apple TOP teacher*  
 'Ikabod gave an apple to the teacher'
- b) Binalik-an ko ang aking pinanggaling-an  
*LT-returned A-1sg TOP my LT-came-from*  
 'I went back to where I'd come from'

When the Theme is the topic, topicalization morphology is used that is also used when (some) direct objects are topicalized, involving the prefix *i-*:

66. a) I-binigay ni Ikabod sa guro ang mansanas  
*TT-gave A Ikabod LOC teacher TOP apple*  
 'Ikabod gave the apple to the teacher'
- b) I-sinuot ni Ikebana ang bago niyang damit  
*TT-wore A Ikebana TOP new her dress*  
 'Ikebana wore her new dress'

We can see, then, that Tagalog falls into the class of HAVEless languages in the same way as Diné, Irish and Scots Gaelic. It seems that the generalization correlating lack of HAVE with lack of double object constructions holds in at least one direction. Let us see if it holds in the other direction as well, examining languages with HAVE in our sense (that is, languages where the possessor, whatever its case-marking, c-commands the possessee).

### 3.2.5.6 Languages with HAVE

#### 3.2.5.6.1 English

The correlation has, of course, already been established for English. English undoubtedly has possessive *have* with the possessor c-commanding the possessee, and it equally obviously has the double object construction. Although the realization of the verb is different in possessives and existentials, the existential and possessive pattern together in having the location argument in subject position. The relevant data is given again for convenience in 67) below:

67. a) Locative The basselope is in the meadow.  
b) Possessive The basselope has a dandelion.  
c) Existential There is a dandelion in the meadow  
(in most lgs: In the meadow is a dandelion)  
d) Double object The basselope gave Ronald-Ann a book.

#### 3.2.5.6.2 Japanese

Japanese (SOV) is a more interesting case. The existential verb *aru* is used to express possession, and the possessor in a possessive construction can bear the dative case of an indirect object. The possessee takes the nominative case of a subject. It might therefore appear as if the Japanese case patterned with the HAVEless languages above, in that the Location argument appears to be prepositionally case-marked. Crucially, however, the dative subject in these instances is clearly a subject, rather than an object; it can trigger subject-honorification and antecede a reflexive in the possessee, and it cannot contain a reflexive:

69. a) Possession  
John-ga/ni zibun-no uti-ga aru  
*John-N/D self-gen house-N exist*  
"John has his house"  
**Location/Possessor Theme V**

- b) Subject Honorification  
 Tanaka-sensei-ga/ni<sub>j</sub> musume-san-gaj o-ari-ni/\*<sub>j</sub> naru  
*T-Prof-N/D daughter-N exist-honorific*  
 Professor Tanaka has his daughter”
- Binding  
 c) \*Zibun<sub>j</sub>-no musume-ni Tanaka<sub>j</sub>-sensei-ga aru  
*self-gen daughter Tanaka-Prof exist*  
 “His daughter has Professor Tanaka”

Further, the possessive construction patterns with the existential construction: the locative argument is in subject position:

70. Existential  
 Tuke no ue-ni hon-ga aru  
*Table-G top-D book-N exist*  
 “On the table are books” (“There are books on the table”)  
**Location Theme V**

Japanese thus has HAVE in the sense we require.

Now, consider a clause whose verb is the typical double-object verb *give*. Trickily, no matter what order the two internal arguments appear in, the Goal/Location object is marked with the dative *ni*-marker. Japanese has a process of scrambling, and the two orders indicated in 71) below could conceivably be derived via scrambling of one argument across the other. It is well known in Japanese, however, that the *ni*-marker is ambiguous between a preposition and a case-marker<sup>54</sup>. If it can be shown that in one order, the *ni*-marker is a case-marker and in the other order it is a preposition, we have evidence that there is a dative-shift alternation in Japanese.

Miyagawa (1995) convincingly shows that this is indeed the case. Consider the two possible orders for the internal arguments in 71) below:

71. a) Bugs-ga Daffy-ni piza-o ageia  
*Bugs-N Daffy-D pizza-A give-Pst*  
 “Bugs gave a pizza to Daffy”

<sup>54</sup>See Sadakane and Koizumi (1995) for discussion.

- b)      Bugs-ga      piza-o      Daffy-ni      ageta  
           *Bugs-N*      *pizza-A*      *Daffy-D*      *give-Pst*  
           “Bugs gave Daffy a pizza”

I will not go over all of his evidence here. I will present one telling argument, however. Numeral quantifiers associated with a *ni*-marked argument can appear “floated” to the right of their argument only when the *ni*-marker is a case-marker. A numeral quantifier to the right of a prepositional *ni* downgrades the grammaticality of a sentence significantly. In the 71a) case, where the dative argument precedes the accusative argument, floating of the quantifier is legitimate, suggesting that the *ni* in this case is a case-marker. In 71b), on the other hand, where the accusative argument precedes the dative argument, floating of the quantifier produces a marginal sentence, indicating that the *ni* is a preposition. These facts can be seen in 72 a) and b) below.

72.    a)      Bugs-ga      tomodati-ni    2-ri    piza-o      ageta  
           *Bugs-N*      *friends-D*    2-CL    *pizza-A*      *give-Pst*  
           “Bugs gave two friends pizza.”
- b)      ???Bugs-ga    piza-o      tomodati-ni    2-ri    ageta  
           *Bugs-N*      *pizza-A*      *friends-Prep*    2-CL    *give-Pst*  
           “Bugs gave pizza to two friends”

Note that the word-order facts correlate with the English double-object construction word-order facts: when the Goal argument is introduced by a preposition, the Theme precedes the Goal, as in the English double complement construction. When the Goal argument is introduced by a case-marker, the Goal precedes the Theme, as in the double object construction. Any analysis proposing to derive the above ordering alternations using optional scrambling of one argument over another cannot account for the difference in the status of *ni* between the two<sup>55</sup>. Thus, we can conclude that Japanese is a language with prepositional HAVE, and also has a double object construction, supporting our correlation.

---

<sup>55</sup>The difference between prepositional and dative *ni* will be important in the analysis of Japanese analytic causatives in chapter 4 below.



### 3.2.5.6.3 Georgian

Georgian is another language which has HAVE in the sense we are interested in. *Have* in Georgian is derived via the affixation of an applicative morpheme to the copula stem. Further, the existential and the possessive pattern together with respect to the ordering of their arguments; the locative argument preceding and c-commanding the theme argument. Examples of an existential and a possessive are seen in 73) below; evidence that the possessor c-commands the possessee can be seen in the example where the possessee contains a reflexive, 74) below. Georgian is like Japanese, above, in that the possessor receives dative case, while the possessee takes nominative; this case-marking, however, does not reflect their basic structural position, as in the Japanese case above (see the discussion of case realization in Chapter 5). (Georgian examples here from Nash (1993):162,166).

73. a) Existential  
 Magidaze natura -a  
*Table-on lamp-N- COP (cl)*  
 “On the table is a lamp” (“There is a lamp on the table”).  
**Location Theme V**
- b) Possessive  
 Bavšvs Cigni a-kv-s  
*Child-D book-N Appl-COP-3sg*  
 “The child has a book.”  
**Location/Possessor Theme V**
74. Bavšvebs; marTo ertmaneti; h- ø- qav- d-at am kalakši  
*Children-D only each other-N 3obj-Appl-COP-Pst-3pl this city-in*  
 “The children had only each other in this city.”

Georgian also has something resembling a double object construction: in the present tense, the Goal/Location argument can appear in the dative case (along with a dative Theme argument), triggering object agreement on the verb (75a))<sup>56</sup>. In the perfect, Georgian patterns with the double-complement construction, in that the Goal-Location element must

<sup>56</sup>75a) involves addition of an applicative affix, making it perhaps appear more like the Bantu case discussed in fn.41 above; in the absence of further evidence, however, we will assume double object/double complement status for this alternation.

appear in a prepositional phrase<sup>57</sup>, and cannot trigger object agreement with the verb (75b) (ex. from Holloway-King (1993):97).

75. a) Rezo samajurs ačukebs dedas  
*Rezo-N bracelet-D give-3S.3O.3IO mother-D*  
 “Rezo is giving Mother a bracelet.”
- b) Turnie Rezos samajuri učukebia dedis-tvis  
*Apparently Rezo-D bracelet-N give-3S.3IO mother-to*  
 “Rezo gave a bracelet to his mother.”

A similar alternation can be seen with the verb “ring” (meaning, I assume, the telephone) in 76) below; in this case, the tense in the two clauses is the same (Harris(1981):298):

76. a) Vanom dareka dedastan  
*Vano-ERG rang-3S-3O-II-I mother-at*  
 “Vano rang (it) at his mother’s”
- b) Vanom daureka dedas  
*Vano-ERG rang-3S-3O-3IO-II-I mother-D*  
 “Vano rang his mother (it)”.

In 76a) *dedastan* “mother-at” appears in a prepositional phrase and does not trigger agreement with the verb, while in 76b) *dedas* appears in the dative case and triggers verbal agreement, indicating object status. Georgian therefore has both HAVE in the sense we are interested in here and a true double object construction.

### 3.2.6 Some implications

#### 3.2.6.1 Auxiliaries:

One attractive consequence of analyzing *have* as BE+P is that a uniform account of their occurrence in auxiliary constructions in English follows. Consider the passive and perfective sentences in 77) below:

<sup>57</sup>Interestingly, the perfective tense is also the line along which the split-ergativity of Georgian splits, surely not a coincidence, but left for future research.

77. a) Passive  
A tuna fish sandwich was eaten (by Hobbes)  
b) Perfective  
Hobbes had eaten a tuna fish sandwich.

Imagine that the *-en* morpheme in both cases is a realization of a non-external argument-selecting Event head within the I-syntax (BE), as diagrammed in 81) below, and that the auxiliaries are reflexes of higher Event heads (purely an Event head in the case of *be*; an Event+P in the case of *have*). *Have* licenses an argument by virtue of its P complement, which expresses a relation between an element and the embedded EventP, while *be* cannot, as it is a realization of a non-external argument selecting Event head pure and simple. Auxiliaries, then, are merely stackings of subjectless Event heads, expressing relations between them<sup>58</sup>.

78.

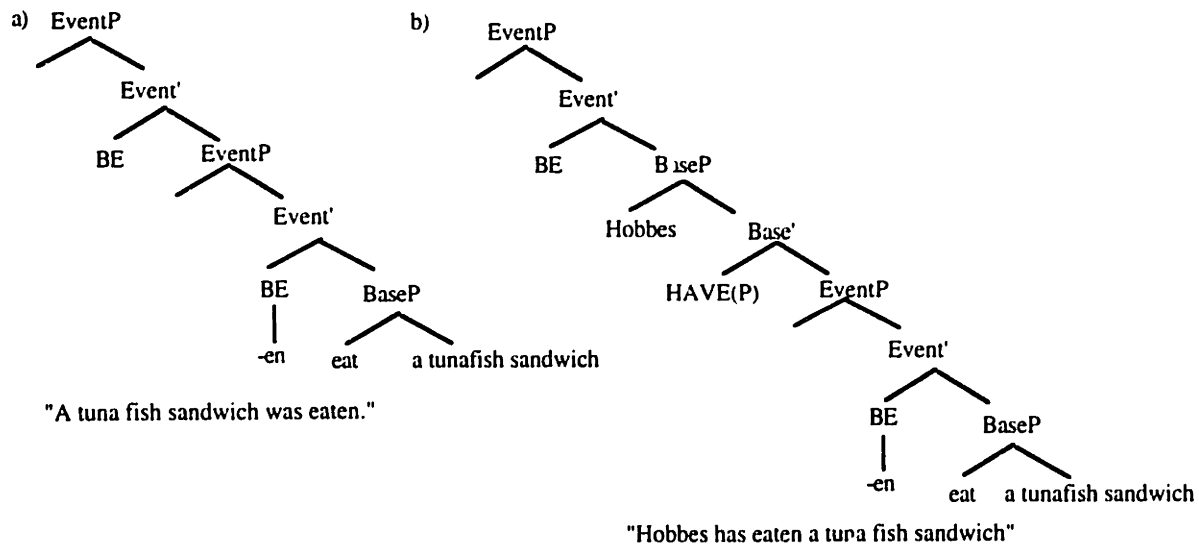

This approach does not account for the "implicit argument" phenomena that accompany the passive and middle constructions (no such phenomena are associated with the zero-derived inchoatives (see, e.g. Keyser and Roeper (1984)), but a thorough investigation is beyond the scope of this discussion, although see the discussion in Chapter 5 below. An account like that of Baker, Johnson and Roberts (1989) could be imported

<sup>58</sup>The notion of relation here is between an entity and an event that is temporally distinct from the event head introducing the entity, resulting in the "over with respect to the matrix event" interpretation of a perfective.

into these structures, according to which *-en* is in some sense the external argument; I will not attempt to resolve the issue here. What the *have* = BE+P does accomplish is establishing the connection between the perfective and passive participles. For further discussion of this approach, see section 5.4.2 below.

### 3.2.6.2 Causative and Experiencer *have*

Other uses of English *have* exist, as discussed in Ritter and Rosen (1993) and briefly in section 3.1.3 above. A sentence like (79) below has two possible readings, the first like the “experiencer” reading:

79. Calvin *had* Hobbes break the spine of his comic books (on him).

The reading intended for this sentence is one in which *Calvin* is (adversely) affected by the embedded event. This interpretation parallels nicely the interpretation for the double object constructions seen above: the Goal object in a double object construction is projected in the same position as the affected subject here—in the specifier of a HAVE PP—and said Goal object necessarily is interpreted as an affected object. (No such interpretation is required of a Goal object in a double complement construction (c.f. Oehrle (1976)).

There is another possible reading for the sentence in (82) (without the “on him” adjunct)—a causative reading (cf. the discussion in section 3.1.3 above). Ritter and Rosen (1993) propose that the structures for the two types of reading are the same, and that the difference in interpretation results from the effect the subject of *have* has on the aspect of the embedded event: if it changes the end point of the event by extending the *duration* of the event, the experiencer reading results (the experience of the event continues after the event itself); whereas if it extends the duration of the event by *initiating* it—that is, if it changes the beginning point of the event—the causative reading results. For Ritter and Rosen, the

syntactic structures of the two are identical. On the analysis presented here, the structures of the two differ: causative *have* is a realization of a CAUSE Event head, plus some Base phrase that represents the difference between *have* and *make* causatives (similar in many ways to the difference between Japanese *ni-* and *o-*causatives; see the discussion in Chapter 4 below) (83a). The experiencer reading of *have*, on the other hand, has no external subject (as proposed for experiencer verbs in general in Chapter 5 below), which is reflected in the structure in 83b)—essentially experiencer “have” is the same as possessive “have”, with the “possessee” being the embedded event.

83.

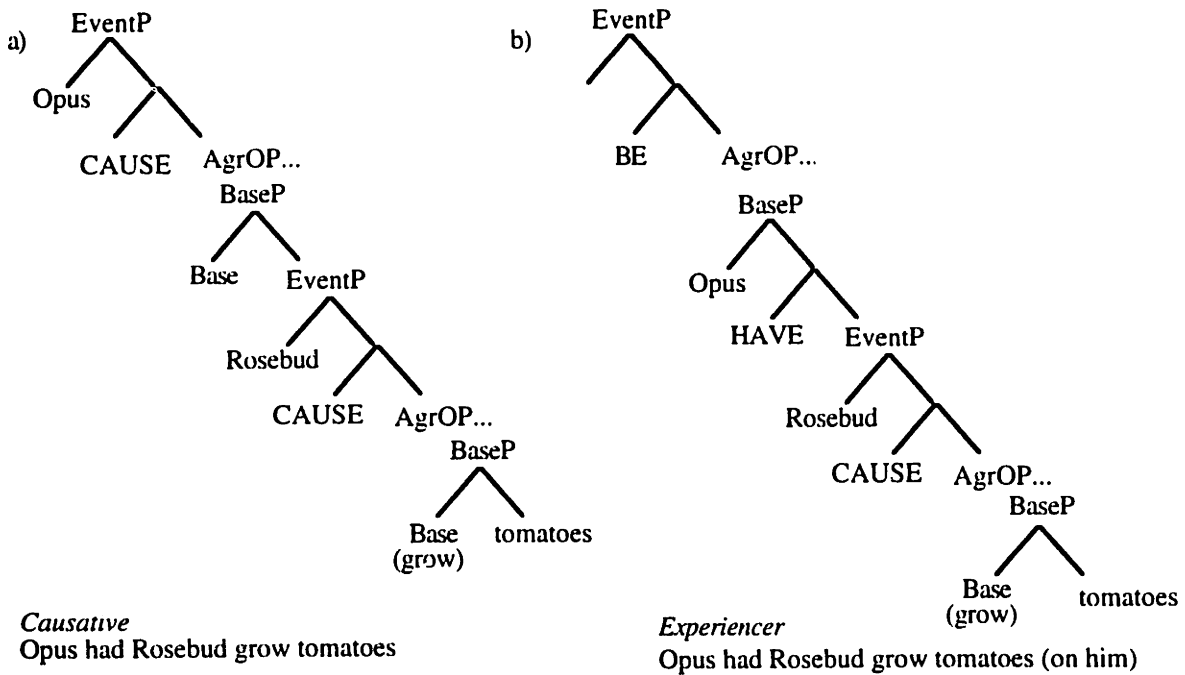

The complements in both constructions are identical, both being Event heads, and Ritter and Rosen's characterization of the effect of the experiencer vs. causer subjects on the aspect of the embedded event can be maintained. Indeed, this account is to be preferred in that it captures a cross-linguistic tendency for some experiencer subjects to pattern with the subjects of unaccusative verbs—that is, neither are generated in external argument position. Further, affecting the endpoint of an event—that is, its telicity—is a property of internal arguments, rather than external arguments, as discussed extensively in Tenny (1987,

1991), while affecting its beginning point is the prerogative of agents, represented as causers, generated in the specifier of EventP. Hence, generating the experiencer subject in an object position seems preferable to the Ritter and Rosen approach. (For further discussion of causative “have” see section 5.4 below).

There does seem to be some evidence<sup>59</sup> that the structures of experiencer and causative *have* are different, although an analysis must await future research. Consider the following sentences:

84. a) Calvin had milk poured on him.  
b) Calvin had milk poured on himself.

In the judgment of most of the English speakers I have consulted, both the causative and experiencer readings are available in 84a). In 84b), however, only the causative reading is available.

The reflexive in this case seems to be logophoric, rather than anaphoric, as the sentence is somewhat degraded when *himself* appears in an argument position (Alec Marantz, p.c.):

85. ??Calvin had a book given to himself.

Nonetheless, the clear difference in possible readings between 84a) and b) indicates some significant syntactic difference between the experiencer and causative *have* constructions. Such a difference exists on the account presented here, although it is not clear to me how to connect it to the facts above; still, the possibility of a syntactic account of 84) exists. Conceivably, logophoric anaphora could require an Agentive/external argument antecedent, or some such restriction. This could be related to the fact that when a *by*-phrase is added to the causative in 84b), the sentence becomes noticeably degraded:

86. ??Calvin had milk poured on himself by Hobbes.

I will leave the correct characterization of these phenomena for future research.

---

<sup>59</sup>Thanks to Andrew Carnie for noticing these facts.

3.2.6.3 *Other Possible Complements of EventP: CP, TP*

We have seen that EventP can take AP, NP, PP<sup>60</sup> and EventP complements, and have proposed the notion that in some sense, word-level interpretation depends on being contained within one Event, as delimited by an EventP. There are complementation possibilities that we have not explored, however. These are diagrammed in 87 below:

87.

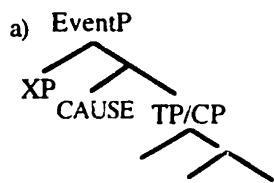

(Calvin forced Hobbes to go?)  
(Calvin allowed that Hobbes should go?)

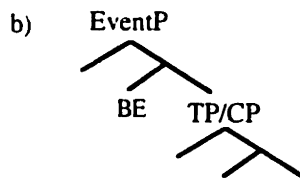

(Hobbes is to go?)  
(Is it that Hobbes is to go?)

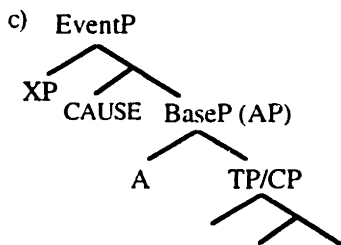

(Calvin asked Hobbes to go?)  
(Calvin said that Hobbes should go?)

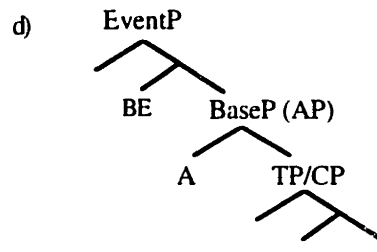

(Calvin seemed to hug Hobbes?)  
(It seemed that Calvin hugged Hobbes?)

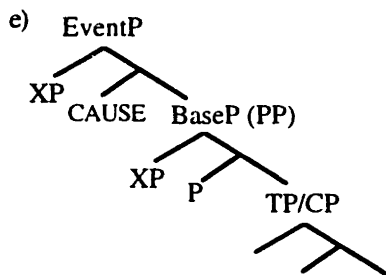

(Calvin persuaded Hobbes to go?)  
(Calvin wagered \$20 that Hobbes would go?)  
compare: Calvin wagered \$20 on the race  
Calvin persuaded Hobbes of his error

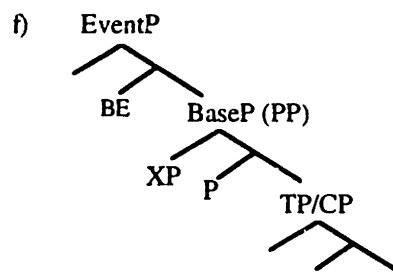

(Calvin wanted Hobbes to go?)  
(Calvin wanted that Hobbes should go?)

<sup>60</sup>That is, complements with no complement or specifier, just a complement, or both a complement and a specifier, as illustrated in example 44 above; AP, NP, and PP are merely notational conveniences, as are CAUSE (EventP with specifier) and BE (EventP without specifier).

As suggested by the example sentences in 87a)-f)<sup>61</sup>, I hypothesize that the structures in which EventP or EventP+Base takes a TP or CP complement constitute the verbs which take propositional complements of various types. The complement TP or CP evidently does not participate in the I-syntax of the matrix EventP; this is conceivably because they are functional projections of the embedded EventP—TP and CP complementation will inevitably involve at least two EventPs<sup>62</sup>. It is beyond the scope of this chapter to exhaustively examine the various classes of verbs which take propositional complements and their various properties with respect to, e.g., ECM; it is left to future research to investigate the plausibility of this sort of typology and its implications.

#### 3.2.6.4 *VP Adverbials revisited*

The lower type of VP adverbial, which can only appear after the verb (as discussed in section 3.2.3 above) is on this account licensed by adjoining to BaseP, which corresponds to Koizumi's inner VP. This type of adverbial modifies the manner of realization of the event, never the event itself. Breaking the verb into two semantically significant subparts, one of which is responsible for licensing the external argument and the other for the internal argument(s), provides a reasonable account for the restricted interpretation of the lower adverbial, while maintaining the most restricted account of possible adverbial placement.

---

<sup>61</sup>The possibility of a prepositional complement in the 87e) type of construction is suggested by the use "bet \$20 on Hobbes' going"; presumably "Hobbes' going" and the EventP complement to the locative in 87e) bear the same relation to the matrix EventP.

<sup>62</sup>This is somewhat reminiscent of the VP and CP boundaries to word-formation adduced in Pesetsky (1994) and (1994b): null CAUSE affixes prevent further word-formation, as do null C<sup>0</sup> affixes. For this account, however, the CAUSE affix within the I-syntax is not necessarily always null (as in Japanese), and we do not adopt Pesetsky's (1994a) contention that there are no TP complements; for us, TP complements and CP complements are both possible, and the distinction between I-syntax and clausal syntax is the result of the relation of a head to the Event phrase with which that head is connected.



### 3.2.7 Conclusion

This section has been something of an excursus on the internal structure of the VP. “External” subjects are analyzed as heading a projection I have called EventP, delimiting the event denoted by the verb, and also coinciding with the domain of what Hale and Keyser (1993) have termed I-syntax. The lexical causative in Japanese is argued to support such a view, as it often bears morphological reflexes of the Event head. “Verbs” are PF realizations of combinations of morphologically complex elements. They consist of the Event head (which has two varieties, CAUSE (selecting an external argument) and BE (not selecting an external argument) in combination with one of three basic syntactically defined structures, which in English correspond roughly to the categories N, A and P (following Hale (1995)). Evidence for this morphological complexity was adduced in the form of a correlation between the presence of the prepositional element HAVE in a given language and the appearance of a double object construction in that language. The analysis of HAVE as a prepositional element in combination with an Event head is argued to allow felicitous accounts of *have* as an auxiliary and also as an experiencer verb.

Having pinned down the position of base-generation of subjects—rather, base-generation of external arguments—we can now proceed to the question of clausal licensing of subjects. Subjects, whether base-generated as internal or external arguments, must appear some sort of relation with the functional projections of their clause, particularly Tense. This relation has been the locus of most of the discussion of subjects in the literature, involving framework-engendering issues like Case Theory and the Extended Projection Principle. We turn to these matters in Part II.



## PART II: LICENSING

---

In Chapter 2 we saw that there is substantial evidence that all subjects, both agentive and otherwise, are generated in some projection below Tense in a given clause. We then presented arguments (Chapter 3) that "external" subjects (Agent, Causer) are generated in a projection separate from the projection in which objects are generated; that is, that the VP is *always* a series of stacked shells in the sense of Hale and Keyser (1993), whether it is unaccusative, unergative, transitive, or ditransitive. We know, however, that both subject and object NPs must move from their base-generated positions. We assume that this is because there is some licensing requirement that must be met.

I have avoided making my assumptions about questions of licensing and case particularly clear throughout the discussion, although a particular framework for case-assignment was adopted more or less unannounced in Chapter 2. In the discussion of the arguments for a Split VP hypothesis in Chapter 3 above, crucial use was made of the presence of AgrO to provide a principled account of adverb licensing facts and a locus for overt object movement within the VP. It was assumed that this projection was the locus for the checking of abstract accusative case. In addition, the appearance of dative-marked NPs and PPs in subject position in much of the discussion of possessives, existentials and locatives went unremarked; those nominals for the purposes of the discussion were subjects, c-commanding their objects, in spite of their peculiar case properties.

In this section, we will examine these and other mismatches between the morphological realization of case and “subjecthood”. We begin with a brief discussion of the problems of using the same notions of locality to condition case-assignment and theta-assignment alluded above, and conclude that assuming an Agr-based case system like that of Chomsky (1992) provides an optimal solution to some of these problems. I will then propose a characterization of the realization of structural case as a dependency relation between licensed NPs, *à la* Marantz (1991), adducing evidence from Icelandic and Japanese quirky case-assignment. This view of case-assignment is crucial to an account of subjecthood mismatches, as (particularly in the Relational Grammar literature) morphological nominative case is taken to be a diagnostic of subjecthood. I demonstrate that this view of morphological nominative is unwarranted, and suggest that the crucial licensing parameter in question is Chomsky’s (1980) Extended Projection Principle.

## 4 *Realizing Case*

---

Case theory is an account of the distribution of nominal elements. Consider the sentences in 1) below:

1. a) It is rare [(that) Dot polkas badly].
- b) \*It is rare [Dot to polka badly].
- c) It is rare [to polka badly].
- d) It is rare for [Dot to polka badly].
- e) Yakko believes [Dot to polka well].

We are concerned here with the embedded clause. The embedded finite clause in 1) is perfectly grammatical. The embedded infinitive in 1b), however, is ungrammatical with an overt subject; when the subject does not appear overtly, it becomes perfectly felicitous, in 1c). The subject can re-appear, however, in 1d), when *for* appears next to the subject. Further, the infinitival complement in 1e) is well-formed with a subject; the difference is in the verb in the matrix clause.

The familiar paradigm above suggests that there is something in 1a), 1d) and 1e), not present in 1b), that allows the subject of the verb *polka* to be overtly realized<sup>1</sup>. In 1a), *polka* is finite; in 1d) *for* appears, and in 1c) the verb which takes the infinitive complement is different. Similarly, in 2a) below, a nominal *the station* can appear in the complement to the verb *walk* when it is introduced by the preposition *to*; without the preposition, the presence of *the station* makes the sentence ungrammatical. When the verb in question is *call*, however, the nominal *the station* is a perfectly well-formed complement (2c)).

2. a) Calvin walked to the station.
- b) \*Calvin walked the station.
- c) Calvin called the station.

The first thing one notices about the well-formed nominals above is that they are close to the element that seems to vary with their appearance. The subject *Dot* is close to the finite verb *polkas*, the preposition/complementizer *for* or the verb *believe* in 1; the object *the station* is close to the preposition *to* or the verb *call* in 2)

#### 4.1 Case Theory

Case theory is the hypothesis that these varying elements have something in common that allows them to license the appearance of a nominal element—that is, they have the ability to assign case to an NP. NPs are subject to some version of the Case Filter, in 3) below (this edition from Haegeman (1991):156):

#### 3. The Case Filter

*Every overt NP must be assigned abstract case.*

Then, all that needs to be said to characterize the pattern in 1) and 2) above is that the elements which appear to allow the presence of an NP can assign abstract case, hence licensing the appearance of the NP. Prepositions, finiteness, and verbs like *call* can all

---

<sup>1</sup>Another way to think of these alternations might be that something extra appears in 1b) that *prevents* the subject from appearing that does not appear in 1a), d) and e). Characterizing the difference between 1b) and 1d) in this fashion, however, seems difficult in that it is in 1d) that an extra morphological element appears. In some sense, however, this is the approach to 1d) that will be taken below.

assign case.

Case-assignment is crucially a local relation. Consider the paradigm in 4) below:

4. a) [CP That Dennis is a menace] is widely believed.  
b) [NP Mr. Wilson's assertion that Dennis is a menace] is widely believed.  
c) It is widely believed [CP that Dennis is a menace]  
d) \*It is widely believed [NP Mr. Wilson's assertion that Dennis is a menace].

The CP in 4a) does not need case, as it is not an NP and not subject to the Case Filter. The NP in 4b) does need case, which it can get from the finite tense. In 4c), the CP can appear in complement position, while in 4d), the NP cannot. This is accounted for if case-assignment is a local relation. The passive participle *believed* by hypothesis cannot assign case; the only case-assigner in the clause in 4d) is finiteness. The NP *Mr. Wilson's assertion* must move to be in a local relation with finiteness so it can be assigned case; if this movement does not take place, case-assignment cannot occur and the construction is thus ruled out by the Case Filter. On the other hand, the Case Filter does not apply to the CP, and hence movement out of complement position is optional, given insertion of expletive *it*, as seen in 4c).

The particular characterization of locality required to capture the various relations between case-assigners and their assignees has been the focus of much discussion. The various structural relations in which case was assigned are diagrammed in 5) below:

5.

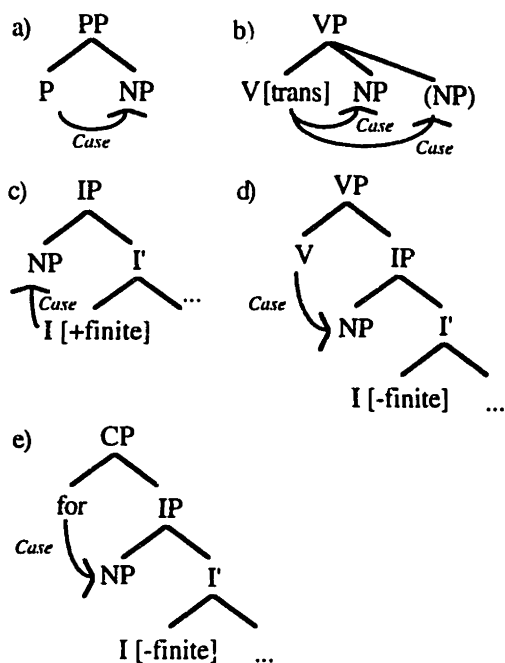

All of these relations are local in some sense—we can see that the elements receiving case are not very far away from the elements assigning it—but the relations involved are quite different from each other, X'-theoretically. In 5a) and b) the relationship is quite straightforward—sisterhood with the case-assigning head. In 5c), however (the case of the subject of a finite clause), the relationship is between the case-assigning head and its specifier. In 5d) (ECM) and e), the relationship is different yet again, being between the case-assigning head and the specifier of its complement.

The morphological realization of this case was determined according to which head did the assigning. If the finite I head assigns case, it is realized as nominative; if the V assigned case, it is realized as accusative (hence “abstract nominative” and “abstract accusative”). Crucially, these cases had nothing to do with  $\theta$ -role assignment. Case could be connected to  $\theta$ -role assignment, however; such case is inherently associated with a given  $\theta$ -role, hence “inherent case”. Inherent case assignment did not necessarily license a noun; as we shall see below, if it was assigned by a verb to either its subject or its direct object, that nominal still needed to be licensed by abstract nominative or accusative, which



was not morphologically realized. The phenomenon of a non-nominative or accusative-marked nominal behaving as though it still required licensing by abstract case is known as “quirky case.” The assignment of inherent case, connected as it is to  $\theta$ -marking, is subject to the same locality restrictions as  $\theta$ -assignment.

#### 4.1.1 Case and the VP-Internal Subject Hypothesis

As long as subjects were base-generated in the specifier of IP, and there was no element generated in the specifier of VP, the properties of the case-assigning heads could be consistently characterized: each of the above relations counted as some sort of government. With the introduction of the ISH, however, problems arose. Suddenly, the relationship between the V and the subject was the same as the relationship between I and its head; further, the relationship between I and the subject in the specifier of VP will be the same as the relationship between V and the specifier of Infl in 4d) or between C<sup>0</sup> and the specifier of Infl in 4e) above. Essentially, there is no reason why either the verb should not assign abstract accusative to its specifier, or the finite I should not assign abstract nominative to the subject in Spec-VP.

On many articulations of the ISH, this is considered a good thing—a good locus for cross-linguistic variation. VSO languages, for example, would be an instance where government and hence case-assignment into Spec-VP by the finite I is allowed, permitting the subject to be licensed *in situ* and deriving VSO order merely by raising the V (this proposal is due to Koopman and Sportiche (1991)). This possibility has been taken advantage of in other recent work, e.g. in Guilfoyle, Hung and Travis (1992), Rice and Saxon (1994), Speas (1991), Rice (1992), Holloway-King (1993), etc. An additional notion then needs to be introduced to determine when government into VP by I is possible and when it isn't—in English, it is not possible, while in VSO languages, on this

approach, it is. Koopman and Sportiche propose that the two configurations represent two different types of case assignment. The English type is assignment under specifier-head agreement, while the VSO type is the more familiar assignment under government. Infl can be specified as able to assign case under agreement, under government, or both. This specification must be determined for each case-assigner individually—in English, for instance, the V must always be able to assign case under government, but not under agreement. Optional movement exists when both types of assignment are licensed.<sup>2</sup>

#### 4.1.2 *An Agr-Based Case Theory*

The system of case-assignment introduced in Chomsky (1991, 1992) is more restricted than that of Koopman and Sportiche; rather than continue the attempt to assimilate all instances of case-assignment to government, it is proposed to assimilate all instances of abstract case-assignment to specifier-head agreement, (still by V and T) in Agr phrases posited for the purpose. In cases where movement does not seem to occur, he posits covert movement, after the phonological realization of the derivation (Spell-Out). On this type of system, the locus of cross-linguistic variation is in the “strength” of the morphological features of the agreeing (checking) elements—strong features must check before the derivation is phonologically realized, while weak features need not. Optional movement is the result of optionally strong features. In English, as we have seen in Chapter 3, both subjects and objects move before Spell-Out, indicating that the N-features of both subjects and objects are strong.

Case that is checked in Spec-AgrS is abstract nominative, realized as morphological nominative unless quirky inherent case is assigned. Case that is checked in Spec-AgrO is abstract accusative, realized as morphological accusative unless quirky inherent case is

---

<sup>2</sup>This analysis is strikingly similar in many ways to that proposed in Bobaljik (1995: Chpt. 5).

assigned. In this chapter, I would like to motivate a break between the realization of morphological case and specific Agr projections (specific case-assigners)—abstract case does not determine morphological case. In particular, I argue that nominative marking is not necessarily a test for subjecthood—that is, for movement to a particular syntactic position (in this system, AgrS), even in languages whose predominant case pattern is nominative-accusative. I begin with data from the familiar realm of Icelandic quirky case constructions, and then move on to the problematic case of the Japanese analytic causative.

## 4.2 *The case of the Icelandic experiencer*

Evidence from Icelandic seems to force the conclusion that “structural” nominative (and its corresponding reflex of verbal agreement) must be available in more than one syntactic position. Crucially, it must be available in object position—in Spec-AgrO

### 4.2.1 *Dative-nominative experiencer subject constructions*

As sketched briefly above, Chomsky (1992) proposes that case assignment is a subcase of a broader requirement that abstract features attached to NPs be “checked” against matching features elsewhere before LF. Case, agreement, and tense features are all checked in this way. If any feature fails to be checked, the derivation will crash. In particular, case features on NPs are checked against similar features on the V head and the T head; V in AgrO for accusative and T in AgrS for nominative. The NPs checking these features do so in the specifiers of the AgrPs. The case that they check there is morphologically realized as nominative or accusative if it is not pre-empted by previously assigned quirky case.

Data from experiencer subject constructions in Icelandic demonstrate that structural

nominative can be “checked” in AgrPs other than AgrS, suggesting that the case-realization mechanisms need to be reworked.

#### 4.2.2 *Case in experiencer subject constructions*<sup>3</sup>

In many languages, a certain class of predicates triggers unusual case-marking. They have the common feature that the highest theta-role they assign is “experiencer”. The NP that receives this theta-role typically behaves according to a number of syntactic tests as if it was in subject position, yet is morphologically marked dative. The syntactic object is marked nominative and triggers verbal agreement. An Icelandic example is seen in 6):

6. Calvini líki verkið  
*Calvin-D like the job-N*  
“Calvin likes the job”

Note that this is a common construction cross-linguistically, appearing in Dravidian languages, Japanese, Georgian, Russian and Marathi, among others (see, e.g. Verma and Mohanan (1990), Takezawa (1987), Marantz (1991), Kondrashova (1993), Rosen and Wali (1989); here the focus is on Icelandic, but the widespread nature of the phenomenon suggests that it reflects some fairly deep property of language). I suggest in the next chapter that the problem of quirky case on psychological predicates is intimately connected to the realization of HAVE cross-linguistically. I won’t repeat the extensive tests for subjecthood of the dative argument here; for Icelandic they can be found in their profusion in Zaenen et al. (1985), and are summarized in the appendix to the next chapter, along with tests for subjecthood of the dative nominal in Japanese and Kannada. We are concerned here with the nominative on the object and where it might come from.

---

<sup>3</sup>Many thanks to Hoskuldur Thráinsson for much discussion and data in this and following chapters.

### 4.2.3 Structural nominative

Object nominative in these construction appears to be structural—that is, a property of the position the NP is in, not the result of special marking associated with a  $\theta$ -role, for several reasons.

7. \*Morgum studentum líka verkið  
*many students-D like-3.pl the job-N*  
“Many students like the job”

In 7) it can be seen that the verb must agree in number with the nominative object, just as is the case with structurally nominative subjects—7) is bad because the object is singular while the verb has plural agreement on it. Agreement with a non-nominative, quirky subject is impossible; default agreement shows up. Nominative and agreement are invariably linked in Icelandic.

The crucial test, of course, is whether or not the object nominative is preserved when the NP moves to a position that normally assigns a different structural case—for example, if a passivized experiencer-subject verb were embedded under an ECM verb. Unfortunately, experiencer-subject constructions cannot be passivized, as they pattern with unaccusatives—their Event head does not project an external argument. However, in Icelandic, certain ditransitive verbs, if passivized, produce dative-nominative structures that behave in most respects like experiencer-subject constructions. An example appears in 8)—note that the plural agreement in the passive is with the nominative object<sup>4</sup>:

8.  
a) Við hafa gefnir konungi hestana  
*We-N have-pl given a king-D horses-A*  
We have given a king horses.

---

<sup>4</sup>Some verbs, including this one, allow a default singular agreement form with a plural nominative object. Person agreement is never possible with a nominative object. If nominative is assigned in these instances in AgrO, this is consistent with observations of Murasugi (1993), who notes that in languages with multiple agreement, object agreement cannot be more featurally specified than subject agreement. Alternatively, this could be evidence that the nominative object is only checking features in the lower of two possible agreement heads, the higher of which is specified for 1st and 2nd person agreement and the lower of which is specified for number, following, e.g. Ritter (1994).

- b) Konungi hafa verið gefnir hestar  
*a king-D have-pl been given horses-N*  
 “A king has been given horses”

The first thing to notice about these examples is that the nominative case on *hestar* “horses” in 8b) appears in the passive only—in the active, “horses” receives accusative case. This is the first indication that the nominative on “horses” cannot be inherent case—it is not inextricably connected with the Theme theta-role assigned to “horses”, which presumably does not change from a) to b).

As pointed out by Zaenen et al, when this verb is passivized with “horses” as the subject and embedded under an ECM verb, “horses” is marked not with a quirky nominative, but with accusative, as in regular ECM constructions. This is seen in 9):

9. Eg taldi hestana hafa verið gefna konungi  
*I believe horses-A have been given a king-D*  
 “I believe horses have been given to a king” (Zaenen et al. (1985))

The fact that the nominative marking is not preserved when the argument moves to a different position demonstrates that it is not quirky, but structural. Quirky case is preserved under movement (10):

10. a) Við vitjuðum sjúklinganna  
*we-N visited-1pl the-patients-G.pl.m*  
 “We visited the patients”  
 b) Sjúklinganna var vitjað  
*the patients-G.pl.m was-dflt visited-supine* (Andrews (1990))  
 “The patients were visited”

and under ECM, (11):

11. Eg taldi sjúklinganna var vitjað  
*I believe the patients-G.pl.m was-dflt visited-supine*  
 “I believe the patients were visited”

In short, quirky case is not a consequence of syntactic position, but of the particular relation between a certain verb and the argument in question<sup>5</sup>. (This is, of course, the major

---

<sup>5</sup>On the account of “verbs” proposed in chapter 4, a relation between the Base head and one of its arguments.

reason for positing the “abstract” vs. “morphological” distinction in the first place.) If the nominative in 8) was the result of such a relation between “horses” and passivized “give,” it should appear no matter where in the sentence “horses” surfaced<sup>6</sup>.

#### 4.2.4 *Nominative in T<sup>0</sup>?*

If the object nominative in these constructions has more in common with structural case than quirky case, an account that suggests itself is that these objects are having their case checked in the same place and in the same way as nominative subjects. (An analysis along these lines has been proposed by Schutze (1993a); any RG analysis in which nominative in these constructions is taken to reflect I-hood at some level is also assuming this type of analysis). If that is the case, these objects would be expected to behave in some respects like structural subjects—they would move to Spec-TP or higher, to Spec-AgrS, and check their case against the nominative available on the finite T head. This is attractive in that no revision to the standard case assignment mechanisms need be made. However, such an approach is empirically unmotivated in that nominative objects seem to behave syntactically in every respect like regular objects. (The reader is referred to the next chapter for an extensive discussion of object shift in experiencer-subject constructions and its interaction with the system of case realization proposed below).

##### 4.2.4.1 *Negative Polarity Items*

One argument for assuming that the object does not reach higher than SpecAgrO at

---

<sup>6</sup>Rögnvaldsson (1990) points out that in conjoined phrases with identical objects, the second object can be dropped when marked accusative, no matter what the case of the first object; however, when the second object is quirkily case-marked, it can only be dropped if the first object is identically case-marked. This seems to hold true for nominative objects as well. In this respect, nominative objects pattern with quirky objects rather than structurally case-marked objects; however, as outlined above, the combination of agreement and ECM facts still strongly suggest that nominative is structural in these instances. Some other explanation of the object-drop facts must then be found; perhaps accusative case is “unmarked” in some sense and hence recoverable, while nominative is not.

LF comes from facts about negative polarity item licensing. If the object were in Spec-TP or higher at LF, it would be in an A-position with scope over everything in TP, including sentential negation. A contrast between subjects and objects with respect to NPI licensing would then be difficult to account for, if NPI licensing is affected by scope relations at LF (as argued extensively in Uribe-Etxebarria (1994)). Such a contrast exists. As seen in 12), in Icelandic, as in English, negative polarity items in subject position fail to be licensed by sentential negation, but such items are fine in object position.

12. a) \*Neinir stúdentar luku ekki prófinu  
       *\*any student-N finish not the test-A*  
       “Any students didn't finish the test”
- b) Stúdentarnir luku ekki neinu prófi  
       *Students-N finish not any test-A*  
       “Students didn't finish any test”

Example 13) shows that the same facts obtain for the subjects and objects of dative-subject constructions.

13. a) \*Neinum ketti líka ekki hundar  
       *\*any cat-D likes not dogs-N*  
       “Any cats don't like dogs”
- b) Fifi líka ekki neinir hundar  
       *Fifi likes not any dogs-N*  
       “Fifi doesn't like any dogs”

If the objects are in SpecTP or SpecAgrS at LF, they will not be in the scope of sentential negation, and the NPIs in them should be illegitimate.

#### 4.2.4.2 *Finiteness and Tense*

In any case, the assignment of object nominative is unconnected to questions of finiteness, a major reason for positing Tense as the licenser of abstract nominative on subjects, as the legitimacy of an overt subject is evidently connected to Tense (given the data in 1) above). In 14) and 15), it is clear that nominative case is still assigned to objects in experiencer-subject infinitivals. If structural/abstract nominative is a property of [+finite]



Tense, its assignment here is mysterious.

14. [Að líka slíkir bílar] er mikið happ  
*To like such cars-N is great luck*  
“To like such cars is very lucky”

15. Hann taldi henni hafa verið gefnir hattarnir  
*He believed her-D to have been given hats-N*  
“He believed her to have been given hats” (Jonas (1993))

Further, it has been convincingly shown by Sigurðsson (1991) that even PRO can be shown to receive structural nominative. As is seen in 16) Icelandic floated quantifiers agree in case, gender and number with their subjects.

16. a) Strákarnir komust allir í skóla  
*the boys-N got all-Nplm to school*  
“All the boys got to school”  
  
b) Strákunum leiddist öllum í skóla  
*the boys-D bored all-Dplm in school*  
“All the boys were bored in school”

When the subject is PRO, the floated quantifier agrees with the morphological case the subject NP would have shown were it overtly realized. This can be seen in 17b), where the embedded quantifier agrees with an invisible dative marker on PRO rather than the nominative on the matrix subject.

17. a) Strákarnir vonast til að PRO komast allir í skóla  
*the boys-N hope for to (N) get all-Nplm to school*  
“All the boys hope to get to school”  
  
b) Strákarnir vonast til að PRO leiðast ekki öllum í skóla  
*the boys-N hope for to (D) bore not all-Dplm in school*  
“All the boys hope to not be bored in school”

Crucially, the reverse is also true—if the matrix subject is quirky, and the embedded PRO non-quirky—that is, would have received structural nominative were it overt—the agreement is with the nominative PRO, not whatever the controller’s case happens to be (18) (agreement is with the participle in this case):

18. Strákanum leiddist að PRO verða kosnir/\*kosið í stjórnina  
*The boys-D bored-dflt to (N) be elected-Nplm/\*elected-dflt to the board.*  
“The boys were annoyed at being elected to the board.” (Sigurðsson (1991))

This shows that morphological nominative can be assigned when tense is [-finite].

#### 4.2.5 *The Mechanics of Case*

Thus far, we have seen that according to every structural test, nominative objects in experiencer-subject constructions behave exactly like regular objects. Further, morphological nominative is assigned even in infinitive clauses. This morphological nominative appears in other ways to be the same morphological nominative that appears on subjects, in triggering agreement, and in varying depending on a given nominal's position in a clause. In particular, it is clear that this nominative cannot be inherent—it cannot be assigned with a theta-role. Instead, it appears to be assigned as a kind of “mandatory” case—if nominative is not realized on the subject, because it receives quirky case, then it is realized on the object. The ideal analysis, then, characterize structural case assignment in such a way that it will allow structural nominative to be assigned to objects in object position—that is, in SpecAgrO.

In the spirit of Marantz (1991), I propose that case realization is a purely mechanical process, a morphological property of the clause, rather than of V and/or T. Structural case can be checked in any AgrP; which case is assigned depends on how many NPs check structural case in the clause. Quirkily marked NPs will not require additional morphological case; the Case Filter translates to a requirement that NPs must have *some* morphological case to be well-formed. This enables the crucial competition between quirky and structural case alluded to above. This assignment mechanism can be expressed as in 19), which is modeled on a similar parameter in Bobaljik (1993) and draws on many other characterizations of clause-bound case assignment, notably Yip et al. (1987) and Massam (1985):

19. *The Mechanical Case Parameter* (version 1 of 2)
- a) If one case feature is checked structurally in a clause, it is realized as *Nominative/Absolutive*<sup>7</sup> (mandatory case).
  - b) If two case features are checked structurally in a clause the second<sup>8</sup> is realized as *Accusative/Ergative*. (dependent case)<sup>9</sup>
  - c) The mandatory case in a multiple-case clause is assigned in the *top/bottom AgrP*<sup>10</sup>.

In languages in which nominative case (the mandatory case) universally triggers verbal agreement like Icelandic, the realization of the nominative argument's phi-features on the verb can be seen purely as a reflex of case-checking; when nominative is checked, the phi-features of that NP are realized. Object nominative in Icelandic doesn't trigger person-agreement, perhaps a reflection of the fact that it is checked in AgrOP (cf. footnote 4 above: Murasugi (1994) notes that in multiple-agreement languages, AgrO agreement is often less featurally specified than AgrS agreement, and it is never more specified; perhaps Icelandic AgrO cannot support a full range of phi-features, as she suggests is the case for object agreement in some languages.)

The realization of morphological case on this system is not a property of Tense or the verb (except for lexically specified quirky case). PRO will receive a morphological case in Icelandic (perhaps a realization of the "Null case" assigned to it in the analysis of Chomsky and Lasnik (1993)) just like any other NP, as shown by Sigurðsson. Crucially,

---

<sup>7</sup>The parameter settings for Ergative/Absolutive languages will have Absolutive as the mandatory case, Ergative as the dependent case, and assignment will proceed from the bottom of the phrase upwards. This approach to the realization of case owes much to Marantz (1991) and is somewhat reminiscent of the "Case In Tiers" approach suggested in Yip et al (1987).

<sup>8</sup>"Second" here is not meant in a sequential sense; because of the restrictions on movement, accusative in overt object shift examples will be checked first. These conditions are to be interpreted as well-formedness conditions against which a completed derivation is checked; if the wrong cases have been assigned when all features have been checked at LF, the derivation will crash. If the right cases have been assigned and the conditions of the MCP above are satisfied, the derivation is good (with respect to the MCP).

<sup>9</sup>Bobaljik (1993) points out that in some ergative languages like Basque, or split-ergative languages like Georgian, ergative marking on arguments of intransitive verbs is possible. He argues that in such cases, the intransitivity of the verbs is only apparent, following Hale and Keyser (1991), in which certain predicates (CAUSE, AFFECT, etc.) are represented with a direct object which subsequently incorporates into the predicate. In Basque and Georgian, this direct object affects the case-marking in the clause; in Yup'ik it does not. For further discussion, see Bobaljik (1993) and references cited therein.

<sup>10</sup>Note that ECM and Raising NPs are considered to be part of both the matrix and the embedded clause, as the A-chains they form link the two.

however, the theory of the distribution of NPs is not affected by this story of morphological case realization<sup>11</sup>; some notion of NP licensing is still required to account for, e.g. the difference between the CP and the NP in 4) above. Essentially, the theory of abstract case remains completely intact, on this account. The crucial element is divorcing the account of the morphological realization of case from particular positions in the clause<sup>12</sup>.

### 4.3. *Japanese causatives*<sup>13</sup>

We now turn to further evidence for this view of case—another instance of dependent case-marking, where the realization of a given structural case depends on what other structural cases are assigned in a given clause. The crucial case is that of the analytic Japanese causative, that is, the non-lexical causatives, involving two EventPs. We will see that case-assignment in the instance of the “make” causative (the *-o* causative) is dependent upon how many NPs receive structural case in a given clause, and that case assigned in what is crucially a single syntactic position varies according to what other cases are assigned in the clause. Crucially, this is only true of the “make” causative. In order to control from interference from the other variety of the analytic causative—the “let” causative—I articulate an analysis of both structures, re-examining in a Minimalist framework a promising line of analysis of the Japanese causative first proposed in Terada (1990). The point to keep in mind throughout the following excursus is that the “make” causative is significantly structurally different from the “let” causative, and the evidence for case dependency comes from the variation between structural dative and structural accusative on the embedded subject in the “make” causative.

---

<sup>11</sup> as pointed out to me by Chomsky, p.c.

<sup>12</sup>The reader is referred to the discussion in the next chapter of psychological predicates, HAVE, diachronic syntax and ergativity for speculation about the nature and provenance of quirky dative case in psych predicates.

<sup>13</sup>See Harley (forthcoming) for an earlier version of this discussion.

In the work referred to above, Terada provides much new data which sheds light on the differences between the two variants of the analytic causative referred to above, the “-*ni* causative” and the “-*o* causative” (henceforth the “let” and “make” causatives, respectively). She proposes an analysis which hinges on a stipulated difference between the two causatives with respect to whether verb-raising is a PF phenomenon or actual syntactic movement. Unfortunately, I show that this stipulation cannot be maintained. Tests developed by Koizumi (1994) for syntactic V-raising in Japanese by Spell-Out, when applied to the causative, demonstrate that all affixation is syntactic and thus Terada's proposal cannot be maintained. Some other mechanism must be found to account for the above-mentioned differences.

I suggest that the formalization of insights first proposed in Kuroda (1965) according to which the embedded subject of the “make” causative has status as an object of the matrix CAUSE, allows a satisfactory treatment of the facts discussed by Terada. In the terminology of standard Case Theory, this implies the checking/licensing of abstract accusative case. The well-known case-marking facts of the Japanese causative, however, make reference to abstract “accusative” pointless, as the case-marking on the embedded subject varies according to the number of arguments in the embedded clause—essentially, abstract “accusative” is simply an object-licensing feature. The embedded subject of the “let” causative, however, has no such object status. Case realization, then, will proceed according to the independent morphological process sketched above for Icelandic, influenced by the syntax but not determined by it.

### 4.3.1 *The problem*

#### 4.3.1.1 *Case alternations and the make/let distinction*

The basic peculiarity of the analytic Japanese causative construction that has stimulated so much discussion centers on the case-marking of the embedded subject. If the embedded clause is intransitive, the embedded subject can bear either accusative or dative case. If the embedded clause is transitive, the embedded subject is always marked with dative case.

These facts, however, can be divided into two subcases. The Japanese causative morpheme *-sase-* has two interpretations; as a regular causative (“Mary made John go”) or as a “permissive”, with a sense closer to “allow” or “let” (“Mary let John go”)<sup>14</sup>. (I will use “causer” and “causee” to refer to the matrix and embedded subjects of the former, respectively, and “letter” and “lettee” to refer to the matrix and embedded subjects of the latter). A cluster of syntactic properties distinguish the two constructions from each other in spite of the homophony of the actual verb forms; they differ with respect to passive constructions, the possible interpretation of matrix adverbials, and the scope of “only”

---

<sup>14</sup>The correspondence to the English verbs “make” and “let” is not exact. The key element that distinguishes the two interpretations in Japanese is the volitionality of the embedded subject. As long as the causee/lettee agrees to do the action the causer is instigating, the *-ni* (dative) marker is used (e.g., if a director tells an actor to fall, the causee/lettee “actor” will receive dative case, although the English translation would be “The director made the actor fall”. If the causee/lettee is forced, without his/her consent, to perform the action instigated by the causer, the *-o* marker must be used (in an intransitive embedded clause.)) Hence, a subject that receives an experiencer theta-role cannot be marked *-ni* when the embedded clause is intransitive, as seen below - the subject cannot agree to the caused action, and thus must be a “causee” rather than a “lettee”:

Hobbes-ga Calvin -o/\*-ni waraw-ase-ta  
Hobbes-NOM Calvin-DAT laugh-Cause-Past  
“Hobbes made Calvin laugh.”

I will continue to use “make” and “let” to refer to the two types of causative, but the reader should keep the proviso in mind that the translation is not exact. Perhaps a better translation of the “let” causative would be English causative “have”, discussed in Chapters 3 and 5, which is subject to similar constraints; in the sentence “John had Mary eat cake” Mary must agree to eat the cake. Other interesting parallels exist between the “let” causative and English causative “have”, for instance, the lack of passivization: “\*Mary was had eat the cake (by John)”. It may prove that the structure of the “let” causative argued for above should be extended to the “have” causative of English as well.

when associated with the embedded subject. In addition, whenever the clause has the permissive “let” reading, the only case-marking possible on the causee is the dative marker, *-ni*. On the “make” reading, the causee must be marked accusative, *-o*, when the embedded clause is intransitive, and *-ni* when the clause is transitive (the embedded object uniquely receives the accusative *-o*.) These facts are summarized below, in the examples in 20) and 21) and the chart in 22)<sup>15</sup>:

20. “Let” reading

a) Intransitive embedded clause:

Calvin-ga Hobbes-ni ik-ase-ta  
*Calvin-N Hobbes-D go-Cause-Past*  
 “Calvin let Hobbes go.”

b) Transitive embedded clause:

Calvin-ga Hobbes-ni piza-o tabe-sase-ta  
*Calvin-N Hobbes-D pizza-A eat-Cause-Past*  
 “Calvin let Hobbes eat pizza.”

21. “Make” reading

a) Intransitive embedded clause

Calvin-ga Hobbes-o ik-ase-ta  
*Calvin-N Hobbes-A go-Cause-Past*  
 “Calvin made Hobbes go.”

b) Transitive embedded clause:

Calvin-ga Hobbes-ni piza-o tabe-sase-ta  
*Calvin-N Hobbes-D pizza-A eat-Cause-Past*  
 “Calvin made Hobbes eat pizza.”

22.

Reading of <i>sase</i>	Arguments of the embedded clause	
	Intransitive	Transitive
make	Subj-ACC	Subj-DAT Obj-ACC
let	Subj-DAT	Subj-DAT Obj-ACC

Note that 20b) and 21b) are identical. It might therefore appear that the permissive should be analyzed as forming a natural class with the transitive causative, as both embedded subjects must be marked dative. As will be shown below, however, syntactic differences between 20) and 21) mitigate against such a treatment. Alternatively, the

<sup>15</sup>Note that neither the “make” nor the “let” reading can be the “lexical” causative discussed above, as they both allow clauses with external subjects as complements - they both take EventP complements, in other words.

accusative marking on the causee on 21a) might suggest that the “make” causative involves straightforward ECM; however, were 21) a simple case of ECM, an ACC-ACC pattern would be expected on the arguments of the transitive embedded clause in 21b) (as in English “Calvin made him kiss her”), not the DAT-ACC pattern that in fact occurs. I will claim below that a type of ECM is in fact involved in the “make” causative, but that case-realization must be treated differently than often assumed.

#### 4.3.2 “Make” vs. “Let” readings: syntactic facts

In this section, I will lay out some syntactic facts about the two causative constructions, first noting their essentially biclausal nature, and then highlighting the differences between the two readings with respect to passivization, construal of adverbial elements, and the scope of quantifiers associated with the embedded subject.

##### 4.3.2.1 Biclausal -sase-

Although this paper does not focus on arguing against a lexical-affixation, monoclausal approach to the analytic Japanese causative, I include here one well-known argument for syntactic complementation. For further discussion of the issue, see the discussion in chapter two of Kitagawa (1986), and references therein.

The anaphor *zibun* is traditionally treated as subject-oriented; it can corefer with subjects but not with objects or locative arguments. (It can also corefer with topics or -*ga*-marked (nominative) NPs in multiple-*ga* constructions.) Crucially, both the causer and the causee can antecede *zibun* in both the “make” and “let” -*sase*- constructions, as can be seen below:

23. Calvin<sub>j</sub>-wa Hobbes<sub>j</sub>-ni/o zibun<sub>j</sub>/j-no kuruma-de paatii-e ik-ase-ta  
*Calvin-Top Hobbes-D/A self-G car-by party-to go-Cause-Past*



“Calvin<sub>i</sub> let/made Hobbes<sub>j</sub> go to the party in his<sub>i/j</sub> car.

If the causee/lettee were simply an internal argument of a lexically-formed complex verb *ikase-ta*, it should be unable to antecede *zibun*, just as other non-topic internal arguments are. For example, the dative-marked internal argument of a ditransitive verb cannot antecede *zibun*, as seen below<sup>16</sup>:

24.        \*Calvin-ga    Hobbes<sub>j</sub>-ni    zibun<sub>i</sub>-no    tokei-o    kaeshita  
             Calvin-N    Hobbes/D    self-G    watch-A    return-Pst  
             “Calvin returned self<sub>i</sub>'s watch to Hobbes<sub>j</sub>”

#### 4.3.2.2        Passivization of “make” vs. “let”

As originally noted in Kuroda (1965), causees can become derived subjects (both transitive and intransitive) of a passivized *-(s)ase-*, while lettees (transitive or intransitive) cannot (25a-b);

25.    a)    Hobbes-ga    (Calvin-ni)    ik-ase-rare-ta  
             Hobbes-N    Calvin-D)    go-cause-pass-pst  
             “Hobbes was made to go (by Calvin)”  
             \*”Hobbes was allowed to go (by Calvin)”
- b)    Hobbes-ga    piza-o        tabe-sase-rare-ta  
             Hobbes-N    pizza-A        eat-cause-pass-pst  
             “Hobbes was made to eat pizza”  
             \*”Hobbes was allowed to eat pizza”

Clauses with a causee, whatever their case-marking, thus meet the conditions necessary to undergo passivization, while clauses with a lettee do not.

#### 4.3.2.3        Construal of “agent-oriented” adverbs

Terada points out another structural difference between causatives and permissives: causees can be construed with a matrix “agent-oriented” adverb (26a) while lettees cannot

---

<sup>16</sup>The Hale and Keyser notion of an “internal subject” (a relation borne by the Goal argument here) clearly is not the relevant notion for determining possible antecedents for “subject-oriented” reflexives.

(26b), again irrespective of the transitivity and case-marking of the embedded clause:

26. a) Calvin-ga hitori-de Hobbes-o ik-ase-ta  
Calvin-N alone Hobbes-A go-make-pst  
“Calvin made Hobbes go alone” (Hobbes is alone, not Calvin)
- b) \*Calvin-ga hitori-de Hobbes-ni ik-ase-ta  
Calvin-N alone Hobbes-D go-make-pst  
“Calvin allowed Hobbes to go alone” (again, with Hobbes alone)

#### 4.3.3 *The analysis, part I: clause-bound case-marking*

Given the regular structural differences between the make and let readings, it appears as though the case-marking similarities constitute a more superficial morphological difference, masking the syntactic regularities that correspond to the semantic make/let distinction. This intuition is pursued by Terada, and the account I propose is based on this conclusion as well.

I claim that the syntactic differences noted above result from distinct clause structures in the two constructions. Following Terada, the “let” permissive is analyzed as a control structure, in which the *-ni-* marked “lettee” is an argument of the matrix verb that controls a PRO in the subject position of the embedded clause. As an argument of the matrix *-sase-*, the lettee receives case from prepositional *ni*.. The “make” *-sase-*, on the other hand, selects no object, and takes an EventP complement. It does have an AgrOP, however, to which the embedded subject raises to check its morphological and abstract case. The two structures can be seen below:

27.

a) "Make" causative

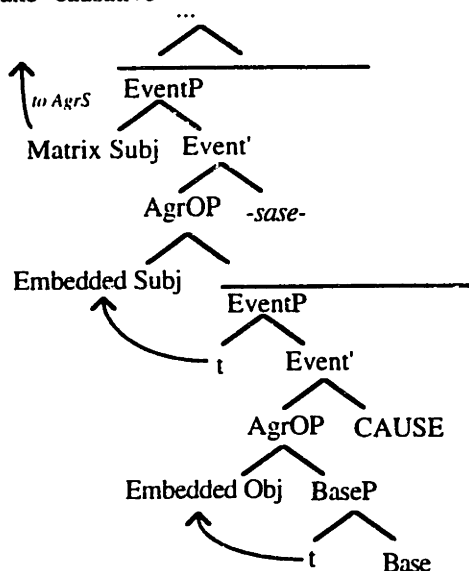

b) "Let" causative

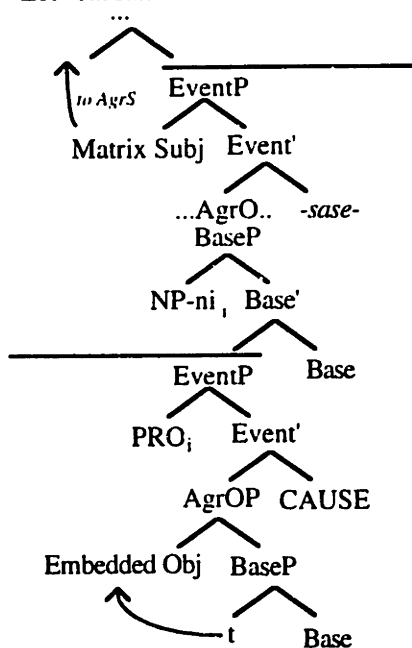

(Movement of the NPs is covert, while (head-)movement of the V head to the matrix Agr position is in the overt syntax; see section 5.3.5.1 below for discussion). The aspect of the above structures to note here especially is that all NPs are moving to Spec-AgrPs for structural case-checking, save the prepositionally case-marked "lettee".

Unlike Terada, I claim that "make" causatives are a true ECM structure, in which

the object raises to the matrix AgrO to check structural case at LF. The case on the causee, whether *-ni* or *-o*, is clearly structural, in our terms. The dative case of the embedded subject of a transitive clause on the “make” reading satisfies one of the crucial tests for “structuralness”—it is not preserved under passivization, as can be seen in 25) above. Japanese does have dative-marked subjects, as can be seen below in 28); the fact that the dative-marked embedded subject is realized as nominative when passivized suggests that the dative case on the “make” reading is structural rather than inherent:

28. John-ni nihongo-ga wakar-u  
*John-D Japanese-N understand-pres*  
 “John understands Japanese”

In addition, the fact that on the “make” reading the case of the causee is affected by syntactic factors like the transitivity of the embedded clause also mitigates against claiming quirky status for said case. Quirky case is associated with a theta role, which should be the same for the embedded subject whether the clause is transitive or intransitive (as it is for the lettee on the permissive reading).

#### 4.3.3.1 *Prepositional vs. case-marking -ni*

Facts from quantifier float suggest that the *-ni* on the “let” embedded subject is actually a prepositional *-ni*, rather than case *-ni*. Recall from the discussion of Q-float in Chapter 3 (section 3.1.5.6.2) above that floating a quantifier away from an NP marked with prepositional *-ni* is considerably more marked than floating an NP case-marked with *-ni*. It seems to be the case that this is another difference between the *-ni*-marked nominals in “make” and “let” causatives: Q-float is possible for a *-ni*-marked embedded subject in the “make” causative, but not in the “let” causative, as seen in 29) below:

29. Yakko-ga otokonoko-ni 2-ri piza-o tabe-sase-ta  
 Yakko-N boys-D 2-CL pizza-A eat-CAUSE-Pst  
 “Yakko made two boys eat pizza”  
 “??”Yakko let two boys eat pizza”

4.3.3.2      *The MCP and the “make” causative*

The case-marking differences between transitive and intransitive causees follow from the assumption that structural case realization proceeds in a top-down fashion, according to the mechanical morphological mechanism outlined in section 4.2.5 above, repeated below with the obvious extra clause below to allow for assignment of three structural cases.

30.      *The Mechanical Case Parameter*

- a) If one case feature is checked structurally in a clause, it is realized as Nominative (mandatory case).
- b) If two case features are checked structurally in a clause the second<sup>17</sup> is realized as Accusative
- c) If three case features are checked structurally in a clause, the second is realized as Dative and the third as Accusative.
- d) The mandatory case in a multiple-case clause is assigned in the *top/bottom AgrP*

Crucially, the definition of “clause” for the application of this mechanism will vary cross-linguistically. In Japanese, the ECM configuration with an impoverished embedded EventP will not be a clause in its own right, hence case assignment in the “make” causative will proceed exactly as in a single-clause ditransitive structure, as it does for the verb “return” in 31) below:

31.      Calvin-ga      Hobbes-ni      piza-o      kaeshita  
          Calvin-N      Hobbes/D      pizza-A      return-Pst  
          “Calvin returned pizza to Hobbes”

---

<sup>17</sup>“Second” here is not meant in a sequential sense; because of the restrictions on movement, accusative in overt object shift examples will be checked first in the syntax. The MCP is to be interpreted as a morphological well-formedness condition against which a completed derivation is checked; if the wrong cases have been assigned when all features have been checked at LF, the derivation will crash. If the right cases have been assigned and the MCP is satisfied, the derivation is good (with respect to the MCP). Alternatively, assuming a “Late Insertion” approach to case morphology (Halle and Marantz (1993)), *particular* structural cases might have nothing to do with the syntax at all - as long as an NP has its case feature checked in an AgrP, the correct morphology will be inserted prior to Spell-Out according to the parameter in 30) above. On either view, it is a morphological dependency that determines what cases appear on an NP, rather than syntactic heads.

Masa Koizumi (p.c.) points out that it is possible to maintain cyclic, bottom-up case-checking if “stacking” of morphological cases is allowed; on such an account two cases (nominative, then accusative) could be assigned to an ECM object and only the outer one realized, giving the correct accusative morphology. See Kuroda (1992) for a similar proposal; I leave the merits and problems of such a proposal to future research.

By contrast, in English the embedded clause in an ECM structure will count as a clause in its own right, so that case assignment will proceed biclausally. Take the structure in 32) below:

32.

Lucy made [<sub>AgroP</sub>him [ <sub>TP</sub> t help her]]

The MCP will check case in the following sequence:

Matrix clause:

- i) *Lucy* gets Nominative, as the first case-checker in the matrix clause
- ii) *him* gets Accusative, as the second case-checker in the matrix clause

Embedded clause:

- iii) *her* gets Accusative, as the second case-checker in the embedded clause (note that because the chain formed by *him* goes from the embedded to the matrix clause, it counts as having had its structural case checked in both clauses, making it the first case-checker in the embedded clause.

Perhaps the overt verb raising in Japanese to the matrix EventP (see the discussion in section 4.3.5.1 below) vs. the non-overt V-raising in English is the crucial element in determining exactly what counts as a “clause” for case-checking.

#### 4.3.4 *The analysis, part II: syntactic differences*

The remainder of this section is made up entirely of discussion of the syntactic consequences of the different structures proposed for the “make” and “let” causatives in 4.3.3 above, and hence is not crucial to the discussion of the mechanisms of case realization outlined above. The reader who is interested in the consequences of these mechanisms for the overall discussion, then, can skip to the end of the section and beyond. To find out more about the structure of the “let” causative, however, read on.

##### 4.3.4.1 *The “let” causative: scope facts*

As can be seen from the diagram of the structure of the “let” causative in 4.3.3

above, I will follow Terada in claiming that in the “let” causative, the quirkily *-ni* -marked lettee is actually in the matrix, controlling a PRO subject in the embedded clause, for two reasons. The first I alluded to above: the fact that the case-marking on the lettee is invariant suggests that it is in a selection relation with the matrix permissive *-sase*. Quirky case is assumed to be assigned along with a theta-role; I will hence assume that the *-ni* phrase is selected for by permissive *-sase*.

The second reason has to do with some peculiar scope facts noted by Terada. The scope of the embedded subject differs between the “make” and the “let” readings. Take a standard *-sase* sentence with an “only” in the embedded subject:

33. Calvin-ga Hobbes-dake-ni piza-o tabe-sase-ta  
*Calvin-N Hobbes-only-D pizza-A eat-make-PST*  
 “Calvin made/let only Hobbes eat pizza”

The curious fact is that the “only” associated with the embedded subject can have either wide and narrow scope on the “make” reading, but has only wide scope on the “let” reading, as schematized below in 34) and 35):

34. a) make >> only  
 b) only >> make
35. a) \*let >> only  
 b) only >> let

That is to say, 33) when interpreted with a “make” reading can describe two different situations. Imagine three people who could eat pizza, Hobbes, Linus and Wakko, and three people who could make others eat pizza, Calvin, Lucy and Dot. 33) on the “make” reading can describe the situation where Calvin makes Hobbes eat pizza and also makes Linus and Wakko not eat any pizza—only Hobbes eats pizza. This situation corresponds to 34a), when “only” has narrow scope with respect to “make”. 33) on the “make” reading can also describe the situation where *all* the potential pizza-eaters are forced to eat pizza. Imagine that Lucy makes Linus eat pizza, Dot makes Wakko eat pizza, and Calvin makes Hobbes eat pizza. Of all the possible pizza-eaters, Hobbes is the only one Calvin has made eat pizza. This corresponds to 34b), when “only” has wide scope

with respect to “make”.

Interestingly, when 33) is interpreted with a “let” reading, there is only one possible scope for “only”—the wide one. That is, the narrow-scope interpretation for 33) is unavailable (35a), where Calvin allowed the situation to occur where Hobbes ate pizza and Wakko and Linus didn’t. The only possible interpretation is one in which Calvin allowed Hobbes to eat pizza, and didn’t allow Wakko and Linus to—whether or not anyone else allowed Wakko or Linus to eat pizza (35b). “Only” has wide scope over *-sase* on this reading. The situation is most easily imagined if Calvin is a director, and tells Hobbes to eat pizza, but doesn’t direct Wakko or Linus to eat or not to eat. The reading which seems to be unavailable is one on which Calvin as director orders Hobbes to eat pizza and also orders Wakko and Linus not to—the reading on which “only” has narrow scope with respect to *-sase*.

The distinction between these two readings is not so clear for “let” as it is for “make”. It is possible to construct a situation where the distinction is more clear, however. For instance, imagine that Calvin, Lucy, and Dot are prison wardens, and Hobbes, Linus and Wakko are inmates. “Calvin let only Hobbes leave the prison” should have two clearly different possible interpretations. When “only” has narrow scope, Hobbes leaves the prison while Lucy and Wakko do not. When “only” has wide scope, it could be the case that Lucy let Linus leave and Dot let Wakko leave as well as Calvin letting Hobbes leave. It is the first of these two readings that Terada claims is unavailable for Japanese — only the second reading is available when *-sase-* has a “let” interpretation.

If the *ni-* phrase in the permissive, “let” reading is in the embedded clause, the lack of a narrow scope interpretation for a quantifier contained within the subject is difficult to explain. If the *ni-* phrase is selected for by the embedded verb, and is generated as an



argument of it, the quantifier should be able to adjoin to the embedded clause at LF for interpretation, by the operation of Quantifier Raising, giving the narrow scope reading, as is assumed for raising structures in English, for example:

36. [A journalist]<sub>i</sub> seemed [ t<sub>i</sub> to slander every senator].

Both narrow (at least one journalist per senator) and wide (one single, multiply-senator-slandering journalist) scopes are available for the raised subject. In control structures, however, the narrow reading seems to be (mostly) unavailable:

37. [A journalist]<sub>i</sub> wanted [ PRO<sub>i</sub> to slander every senator].

Terada's claim is that because the narrow reading is unavailable, the lettee *ni*-phrase must be base-generated in the matrix clause, and control an embedded PRO. (Note that although the *ni*-phrase itself will not be able to antecede subject-oriented *zibun*, the PRO which it controls will be.)

#### 4.3.4.2 The "agent-oriented" adverbs.

Recall from section 2.1.3 above that one of the syntactic differences between the "make" and "let" readings that motivated the positing of two separate structures was the possible construal of a certain type of "agent-oriented" adverbial. When the adverbial appears between the matrix and embedded subject, it can be construed with the embedded subject on the "make" reading but not on the "let" reading. The facts of 26) are repeated below as 38) for convenience:

38. a) Calvin-ga hitori-de Hobbes-o ik-ase-ta  
*Calvin-N alone Hobbes-A go-Cause-pst*  
 "Calvin made Hobbes go alone" (Hobbes is alone, not Calvin)
- b) \*Calvin-ga hitori-de Hobbes-ni ik-ase-ta  
*Calvin-N alone Hobbes-D go-Cause-pst*  
 "Calvin allowed Hobbes to go alone" (again, with Hobbes alone)

(Construal with the matrix subject is always grammatical.)

These adverbials are "agent-oriented" in that they are difficult to construe with non-

agentive arguments:

39. \*Calvin-ga hitori-de (Hobbes-ni) nagur-are-ta  
*Calvin-N alone (Hobbes-by) hit-Pass-Past*  
 “Calvin alone was hit by Hobbes”

In this respect, the facts of 38) are unexpected — recall from fn. 1 that agentivity is a requirement on lettees, not on causees. If anything, one would expect 38a) to be bad and 38b) grammatical. Terada takes this as further evidence that the *ni*- phrase of the permissive is not in fact the agentive subject argument of the embedded clause, but a non-agentive controller of such an argument. I will assume that this is essentially correct; these adverbs are EventP-adjoined and are construed with the agentive/subject NP projected by the EventP to which it is adjoined<sup>18</sup>. The structures of sentences with subject-oriented adverbials in second position, then, will differ for the “make” and “let” causatives. The structure for the “make” causative is seen in 40) below.

40. Yakko-ga [EventP hitori-de [EventP Dot-o [VP ik-ase-ta]]  
*Yakko-N alone Dot-A go-cause-past*  
 “Yakko made Dot go alone”

When the adverbial occurs between the matrix and the embedded subject in the “let” causative however, it cannot be adjoined to the lower SubjP, as the *ni*-marked NP is in the matrix clause. In order for an agent-oriented adverbial to be construed with the embedded subject in 41), it must occur to the right of the *ni*-marked NP:

41. Yakko-ga Dot-ni; [EventP hitori-de [EventP PRO<sub>i</sub> [VP ik-ase-ta]]  
*Yakko-N Dot-D alone go-cause-past*  
 “Yakko let Dot go alone.”

When the adverb is adjoined to the embedded EventP, appearing to the right of the *ni*-phrase of 38b), construal with the PRO is perfectly felicitous, as PRO can then c-command the adverb. This is seen in 42) below:

42. Calvin-ga Hobbes-ni; [PRO<sub>i</sub> hitori-de ik-ase-ta]  
*Calvin-N Hobbes-D PRO alone go-Cause-Past*  
 “Calvin let Hobbes go alone”.

<sup>18</sup>Construal with the matrix subject will be the result of scrambling, presumably of the matrix subject, or possibly optional movement for case-checking of the matrix subject.

#### 4.3.5 *Causee as matrix object*

There are two major points of difference between the analysis presented above and that of Terada (1990), both connected to the analysis of the facts of passivization presented in 25) above. Recall that the make reading of a *-sase* sentence can be passivized (“Hobbes was made to go”) but the let reading can not (“\*Hobbes was let to go”). This follows, on my analysis, from the causee's status as a matrix object, i.e. from the fact that it needs to check case in the matrix clause. Terada assumes, however, that the causee remains in the embedded clause throughout the derivation, and that a difference in the derivation of the V+Cause compound between the permissive and causative readings is responsible for the failure of the permissive to passivize. Below, I argue that no such difference can exist, as both readings behave similarly with respect to tests for verb raising, and that Terada's analysis of the “make” reading runs into problems with respect to the scope facts in 25) above.

##### 4.3.5.1 *V+Cause—syntactic or morphological?: Terada's analysis*

Terada claims that one essential difference between the “make” and “let” readings of the V+*sase* construction is the level at which the affixation of the verb to the causative morpheme takes place. On the “make” reading, the affixation takes place in the syntax, via head-to-head movement. On the “let” reading, however, she claims that the affixation is a PF process, taking place after the syntax. The affixation of the passive morpheme is a syntactic process, hence, the “make” reading can be passivized, as the V+cause compound is formed in the syntax; the “let” reading, on the other hand, cannot undergo passivization, as the V+cause compound is formed at PF and hence cannot affix to the passive morpheme in the syntax. Her analysis is summarized in the chart below:

43.

	Syntax	PF
“Make”	V + “Make” ⇒ [VMake]	[VMake]
	[VMake] + “Pass” ⇒ [VMakePass]	[VMakePass]
“Let”	V + “Let” ⇒ V + “Let”	V + “Let” ⇒ [VLet]
	V + “Let” + “Pass” ⇒ *[V + “Let” Pass]	*

Assuming a PF approach to affixation of the “let” morpheme, however, is untenable. Koizumi (1995) uses constituency tests such as coordination and clefting to demonstrate that in Japanese, verb raising must take place in the overt syntax, leaving the NP arguments in situ. A coordination example can be seen below:

44. [[Mary-ga John-ni ringo-o 2-tu] to  
 [[Mary-N John-to apple-A 2-CL] and  
 [Nancy-ga Bob-ni banana-o 3-bon]] ageta (koto)  
 [Nancy-N Bob-to banana-A 3-CL]] gave

Lit. [Mary two apples to John] and [Nancy three bananas to Bob] gave  
 “Mary gave two apples to John and Nancy gave three bananas to Bob.”

He argues convincingly that the verb head-moves out of the VP in the overt syntax to at least one functional projection up. Such movement will be string-vacuous in a right-headed language like Japanese; however, its effects can be seen in that two complete argument structures can be conjoined beneath one finite verb. Presumably, the VP, without the overt verb in it, is the constituent being coordinated—the subject and any internal arguments of the verb behave as a constituent with respect to constructions like coordination (in 44)) and also clefting. Across-the-board head-movement of the verb out of the VP has clearly taken place in the syntax.

Crucially, the subject, embedded subject, and embedded object of *both* the “make” and the “let” causative construction can behave as a constituent. In 45) below, it can be seen that they can be coordinated, indicating that the entire [V + *sase* + Past] complex has raised out of the VP to some higher functional projection in the syntax.

45. [Calvin-ga Hobbes-ni ringo-o 2-tu] to [Mom-ga  
*C.-N H.-D apple A 2-CL and Mom-N*
- Dad-ni banana-o 3-bon] tabe-sase-ta (koto)  
*Dad-D banana-A 3-CL eat-CAUS-Past (fact)*  
 “Calvin made Hobbes eat two apples and Mom made Dad  
 eat three bananas” *or*  
 “Calvin let Hobbes eat two apples and Mom let Dad eat  
 three bananas”

These facts clearly show that there can be no difference between the “make” and the “let” reading in the affixation of the matrix *-sase* morpheme to the embedded verb—in both cases, affixation must take place in the syntax, rather than at PF. Hence, the inability of the “let” causative to be passivized cannot result from PF-affixation of the causative morpheme.

#### 4.3.5.2 *Passive and Causative*

The interaction of the passive and causative morphemes on the analysis here has a somewhat simpler explanation. Recall that the embedded subject on the “make” causative is a structurally case-marked NP, while the *ni*-phrase on the “let” causative is in the specifier of a prepositional phrase complement to *sase*. The *ni*-marked element on the “make” causative will be eligible to raise if an EventP headed by *rare* takes the *sase* EventP as a complement, indicating that external-argument-lacking BE is projected in the matrix event head, but the PP *ni*-marked element in the “let” causative will not be able to do so. Note that the argument here is not that accusative case will not be available in the passive, but that PPs<sup>19</sup> are not eligible to raise through case-checking positions. See the discussion of Burzio's generalization in Chapter 5 below.

<sup>19</sup>Again, with overtly realized Ps, not relational BasePs.

4.3.6 *Scope of the causee: “make” causative*

The structure proposed by Terada for the “make” causative can be seen in 46) below:

46.

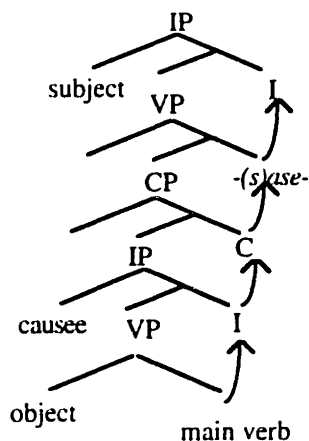

Note especially the causee's position in the embedded clause, where it remains throughout the derivation. This type of biclausal structure predicts that tests for the scope of the embedded subject should give the same result as embedded subjects in any sentential complementation structure.

Embedded subjects in a CP selected by a matrix verb like “think” or “desire” seem to only have narrow scope in Japanese:

47. a) Becky-wa [Bill-dake-ga piza-o taberu koto]-o nozonda.  
*Becky-TOP Bill-only-N pizza-A eat that-A desired*  
 'Becky desired that only Bill eat pizza.'

desire >> only  
 \*only >> desire

- b) Becky-wa [Bill-dake-ga nooberusyoo-o moratta to] omotteiru  
*Becky-TOP Bill-only-N Nobel prize-A received that believe*  
 'Becky believes that only Bill got the Nobel prize.'

believe >> only  
 \*only >> believe

Recall from 34) above that “only” has both wide and narrow scope with respect to “make” in the “make” causative construction. Presumably, Quantifier Raising, i.e. adjunction of the quantifier to its IP, is a clause-bounded phenomenon in 48) above—the quantifier can only adjoin to the nearest IP at LF, forcing adjunction to the embedded IP (here, EventP) rather than the matrix. Terada's structure in 46) would predict that the same should be true of the “make” causative, and only the narrow reading should be possible, which is clearly false.

On an analysis where the embedded causee subject raises to the matrix AgrO at LF, however, both scope interpretations are predicted to exist, just as in the English Raising example in 36) above. The dual interpretation, then, is evidence for a raising-to-object approach to the “make” causative (cf. Koizumi (1994)).

#### 4.4 *Conclusion: realization of case: recap*

Back to the central question of the chapter. We have seen above that an appropriate characterization of the realization of structural case depends not upon what position an NP finds itself in, but upon the relations between structurally-case-marked NPs in a given clause. This approach to the realization of structural case is necessary given the facts of nominative assignment to objects in experiencer constructions in Icelandic and of the dative/accusative alternation on the embedded subject in analytic causatives. This view of case assignment provides a way to account for the peculiar case marking patterns in the possessive constructions in many of the languages we saw in Chapter 3, where nominative occurred on the possessed object, while some prepositional or quirky case marking appeared on the possessor. In the next chapter, I would like to introduce some speculations about, problems with and consequences of the combination of the AgrP case system and the theory of argument projection argued for above.





## 5 *Case, the EPP, and Having Experiences*

---

This chapter opens with discussion of the interaction of morphological and abstract Case and its relation to Burzio's generalization, clarifying the relation between the EPP and the system of case assignment outlined in the previous chapter. Above, we have suggested that psych verbs, perfectives and passives contain a “BE” Event head—that is, they lack a “causer” argument in Spec of EventP, which makes the first two, in which accusative case is assigned, a violation of Burzio's generalization. I propose that the Extended Projection Principle—the requirement that clauses must have a “subject”—is responsible for the distributional phenomena ascribed to abstract Case, and that the appearance of Burzio's generalization is the coincidental result of two interacting systems. The constraints on licensing of *morphological* case outlined above are revised with this approach to licensing in mind. I then move on to discuss the constraints on movement necessitated by a view of clause structure like that proposed in Chapter 3 and the VP-internal case-checking

mechanism for direct objects adopted in Chapters 2 and 4. In particular, I briefly discuss the phenomenon of object shift in Scandinavian languages. Finally, I consider the fact that it can not be a coincidence that the instances in which subjects are marked with quirky dative case cross-linguistically coincide roughly with a class of predicates commonly referred to as “psychological”. This chapter closes with a sketch of a possible diachronic reason for this phenomenon, given the discussion of HAVE and the structure of the EventP introduced in Chapter 3, along with some further speculation about perfectives along the lines of Noonan (1994).

## 5.1 *Burzio's Generalization and the EPP*

### 5.1.1 *Does Burzio's generalization exist?*

Burzio's generalization can be seen (paraphrased) in 1) below:

1. Abstract accusative case is assigned if and only  
if an external theta-role is assigned. (Burzio, (1986))

We have seen several instances in the analyses of various phenomena outlined here in which this generalization is not true—we have analyzed many constructions as underlyingly without an “external subject” (lacking a specifier in EventP) in which abstract accusative case is assigned. For instance, English possessives, psych verbs and perfectives are all cases in which the Event head is a BE — that is, projects no external argument—and yet abstract accusative is assigned to the object with no problem at all.

Burzio's generalization, when considered in closer detail, however, seems somewhat redundant (cf. Marantz (1991)). The generalization is intended to account for the fact that underlying objects in unaccusative and passive constructions fail to be licensed in their base position—they must move to subject position. Under a Burzio's generalization-type account, this is because accusative case is unavailable to the object and hence the

object NP must move to get in a relationship with Infl and receive nominative case, in order to be licensed.

Recall the paradigm of CP and NP distribution from Chapter 4, repeated below:

2. a) [<sub>CP</sub> That Dennis is a menace] is widely believed.
- b) [<sub>NP</sub> Mr. Wilson's assertion that Dennis is a menace] is widely believed.
- c) It is widely believed [<sub>CP</sub> that Dennis is a menace]
- d) \*It is widely believed [<sub>NP</sub> Mr. Wilson's assertion that Dennis is a menace].

When the CP moves to subject position in 2a), it cannot be for nominative case assignment, as it does not require case, given 2c). In 2c), something requires the expletive *it* to appear when the CP fails to raise. It cannot be nominative case, as case-assignment is a requirement of NPs, not of clauses. The appearance of the expletive is attributed to the Extended Projection Principle — the requirement that a given position in a finite clause be filled, or on a feature-checking theory, the requirement that a given feature be checked before Spell-Out. For now, we will assume that this feature is attached to T and is subject to variation with finiteness, given that *\*That Dennis is a menace to be widely believed ...* is bad.

These characteristics are strikingly similar to those of abstract nominative case. If the EPP is a theoretical necessity independent of abstract nominative case, Burzio's generalization is suddenly somewhat redundant. In any clause with only one argument, no matter where that argument is base-generated or case-licensed, the EPP will force the raising of that argument to subject position. The MCP will ensure that the case which is checked on that NP is nominative, no matter what AgrP it checks it in, and the combination of the two phenomena will result in the appearance of Burzio's generalization. The transitive structures without an external argument but with accusative assignment mentioned above will be instances where the EPP forces raising of an NP that is not underlyingly an external argument, but where accusative case is still assigned to another NP in accordance with the MCP.

Indeed, there are examples in Japanese where a true passive assigns accusative case, demonstrating that case-assignment possibilities are not related to argument projection: the so-called “possessor passive”. As demonstrated extensively in Kubo (1990), the Possessor Passive has all the hallmarks of a true passive construction (*by*-phrase, A-movement, etc.) and yet assigns accusative case to an object inalienably possessed by the raised subject NP:

3. Taro-ga sensei-ni kodomo-o shik-rare-ta  
*Taro-N teacher-D kid-A scold-Pass-Past*  
 “Taro had a teacher scold his kid on him.” (Kubo: 8)

This construction is convincingly analyzed by Kubo as involving an empty category in the possessor position of the object—essentially, the nominative subject is base-generated as the possessor of the accusative object and moves out under passivization, stranding the object, which is licensed *in situ* despite the passive morphology on the verb<sup>1</sup>. By hypothesis, then, arguments can check accusative case even in passives; it is the EPP which forces NPs to move to subject position, not a lack of accusative case. (Note that this phenomenon associated with inalienable possession is a peculiarity of Japanese NPs, not of the Japanese passive in this instance; see fn. 1 for another instance where inalienable possession in Japanese allows a violation of an otherwise well-established grammatical precept).

<sup>1</sup>This type of effect of stranding of an inalienable possessee can be seen elsewhere in Japanese. Kitagawa (1986) points out that although extraction of a subject out of a complex NP yields an ECP violation, as in i) below, if the possessor of the complex NP is an *inalienable* possessor of that NP, the ECP violation disappears, as in ii) below. This indicates that the syntax of inalienable possession in Japanese is subject to peculiar constraints; in some sense, the possessor can “stand in” for the whole NP for the purposes of both A-movement (in the passive example above) and A'-movement.

- i) \*Anata-wa [<sub>NP</sub>[donata-ga [gotyoonan-ga gookakusare]-ta] daigaku-o] zyukennasaru otumori desu ka  
*you-Top [[which-person-N [eldest-son-N pass]-Past college-A] apply-to intention is Q*  
 “Which person is such that you intend to apply to the college which his eldest son  
 has succeeded to get in?” Kitagawa:227
- ii) Keioo-byooin-de-wa [<sub>NP</sub>[dare-ga [me-ga mienakunat]-ta] gen'in-ga] kaimei-deki-na-katta no-desuka  
*Keio-hospital-at-Top [[who-N [eye-N lost-sight]-Past] cause-nom] could-not-figure-out Q*  
 “At Keio Hospital, which eye of Mr. Yamada's couldn't they figure out the cause for losing sight?”  
 Kitagawa:231

This phenomenon is useful to us, of course, in that it demonstrates that accusative assignment is not problematic in passive constructions; however, we do not attempt to account for the phenomenon itself here.

### 5.1.2 Case-assignment: no abstract case required

Given this account of movement to subject position, then, we have to re-examine the mechanisms of case-assignment we outlined in the previous chapter. In the previous chapter, we had three notions:

- I) Abstract case—accusative and nominative. All NPs must move overtly to AgrPs to check this case
- II) Morphological case:
  - i) Quirky/Inherent case: a reflex of being generated in a certain position within BaseP (that is, with a certain theta-role)
  - ii) Structural case: the morphological case assigned to an NP that does not receive quirky case—that is, the case realized on an NP in an AgrP depending on what other NPs appear in AgrPs in the clause.

What we would like to consider now is the possibility that abstract Case does not in fact exist—that (as suggested in Marantz (1991)) the effects of abstract Case are fully derivable from the combination of the Extended Projection Principle and (in our system) a version of the Case Filter that requires that all morphological case (quirky and otherwise) be licensed by checking in an AgrP. The EPP corresponds more or less to abstract nominative Case—it varies with the finiteness of the clause (and hence is presumably a feature of Tense). The difference between abstract nominative and the EPP, however, is that the EPP is a feature of a finite clause, which must be checked in the overt syntax (at least in English—see the brief discussion in section 5.3.2 below with respect to weak EPP features in Irish), rather than a requirement on the NP in question. There is still a morphological requirement on NPs, however, as expressed by the reworking of the Case Filter in 4) below:

#### 4. The Case Filter:

- i) All NPs must bear morphological case
- ii) All morphological case must be checked in an AgrP<sup>2</sup>

---

<sup>2</sup>PPs, of course, do not need morphological case; all requirements on NPs licensed by prepositions are settled internally to the PP. This, of course, is a good point to remember that overt prepositions on our

The realization of morphological case will be determined by the MCP as outlined in the previous chapter. Crucially, quirky morphological case will need to be checked in an AgrP, just as structural morphological case does. In a sense, structural morphological case is the default realization—again, one could imagine an “Elsewhere” principle at work at Spell-Out, assigning “structural” case in case more specific quirky case is not assigned. The interaction of these two systems—the Extended Projection Principle and the Mechanical Case Parameter—gives the result of the appearance of Burzio’s generalization, except in the cases where we can tease the effects of the two apart, as in Japanese possessor passives, above.

#### 5.1.2.1 ECM and PRO: Activating AgrP

Something more needs to be said, however. Consider the case of English ECM in 5) below:

5. Hobbes wanted a tuna-fish sandwich to be eaten.

Recall from the discussion of adverb placement in Chapter 3 that ECM subjects in English found themselves overtly in the AgrOP of the matrix clause. Recall from the discussion of Burzio’s generalization above that accusative case is available in the lower AgrOP of passives and perfectives. Why, then, does the object *a tuna-fish sandwich* in 5) raise to the *matrix* AgrOP to check case? So far, nothing we have said will prevent it from checking case in the embedded AgrOP, producing the ill-formed sentence in 6):

6. \*Hobbes wanted to be eaten a tuna-fish sandwich.

Similar facts obtain in Icelandic when the object is quirkily case marked—it must still raise to the matrix AgrOP; it is not licensed *in situ* :

7. a)      Ég taldi          Calvini          líka      verkið  
              *I believe*          *Calvin-D*          *to-like*   *work-N*  
              “I believe Calvin to like work

---

story have licensing properties that unrealized prepositions (Bases) do not, as complements to Base must still check case in an AgrP.

- b) \*Eg taldi líka Calviní verkið  
*I believe to like Calvin-D work-N*  
 I believe to like Calvin work.

How can we ensure that movement to the matrix AgrO takes place? A solution suggested by Marantz (p.c.) is that notion of a dependency relation between AgrPs is not just relevant for determining what morphological case is realized on an NP, but for determining what AgrPs are active in a given clause. Essentially, in order for an AgrP to be active with respect to a given NP at a given point in the derivation, it must be the highest unfilled AgrP in a clause (CP). AgrPs are (by hypothesis) always present, but they can only check morphological case—they are only *active*—when they are not c-commanded by an unfilled AgrP. Given this assumption, then, we can see that movement of the NP in the embedded clause in 8) above to the matrix AgrOP will be forced, as the lower AgrOP will not be active, since it is c-commanded by the unfilled matrix AgrOP. Note that active AgrPs can remain unfilled: presumably in any unaccusative intransitive clause, the embedded AgrOP will become active as soon as the matrix AgrSP is filled by the raised object; it will not, however, be filled, as there is no other NP argument that requires its morphological case to be licensed.

#### 9. The Condition on AgrPs:

Only the highest unfilled AgrP in a CP at a given point in a derivation will be active, where *active* is defined as “available as a potential licenser for morphological case”<sup>3</sup>.

Note that the notion of CP as a boundary for the Condition on AgrPs above ensures that a new case-marking domain will begin with every CP. Control infinitives will be CPs, following Watanabe (1993) which ensures that they will be a separate case-marking domain, with PRO receiving case in AgrSP just like any other NP (see the discussion of Siggurðson (1991) in the previous chapter). In this sense, the EPP truly applies to “one

---

<sup>3</sup>Masatoshi Koizumi (p.c.) points out that this condition is probably better rendered as a condition on output, such that if any NP has landed in an inactive AgrP at LF, the derivation will crash, thus avoiding problems with countercyclicity.

clause” in exactly the grammar-school sense we started out with: every CP must check its EPP features with an NP—that is, every CP must have a subject.

Given this account of the interaction of case and the EPP, then, we are free to analyze any transitive predicate that appears to have no agent as being without an external argument—that is, as lacking an underlying subject (a specifier of the Event head), uniting unaccusative verbs with psych verbs and English perfectives with respect to this movement.

## 5.2 Movement restrictions: *Equidistance and Leapfrogging*

Let us briefly reconsider the clausal configuration adopted in Chomsky (1992) and much subsequent work, seen again in 10) below:

10.

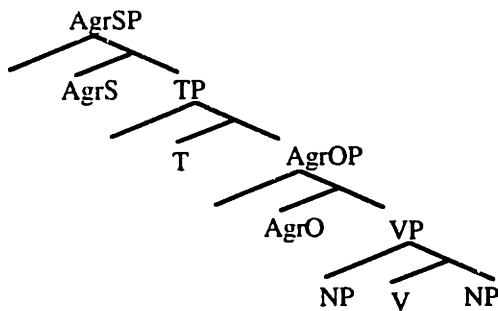

The subject NP and the object NP are both dominated by the same VP projection, above, and the case-checking position for the object is above the position of base-generation for the subject. In order for the object to reach that position, Spec-AgrOP, it will have to move upwards in the tree, crossing the position of base-generation for the subject. This movement is made possible by Chomsky's (1992) principle of Equidistance: as the verb raises upward by head-to-head movement, it creates new domains for the application



of Relativized Minimality. While the verb remains *in situ*, the object cannot raise out of the VP, as it would have to cross a possible landing site — the A-position that is the position of base-generation of the subject. If the verb raises to AgrO, however, the principle of Equidistance applies: the specifier of AgrOP and the specifier of VP will be *equidistant* from the object, and movement to Spec-AgrOP, across Spec-VP, will then be allowed.

### 5.2.1 Holmberg's Generalization

This account of movement for case-checking has the attractive consequence of providing a possible account of Holmberg's Generalization, as argued in Bures (1992), Jonas and Bobaljik (1993), Bobaljik and Jonas (forthcoming) and other subsequent work. Roughly stated, the generalization says that overt object shift (OS henceforth) only occurs in those languages which exhibit overt verb raising. If the verb does not raise overtly, the domain for the application of Relativized Minimality will not be expanded, and the object will not be able to rise outside the VP before Spell-Out. An example of a sentence with overt object shift is seen in 11b). below:

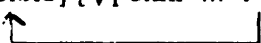
11. a) Morgum stúdentum líkaði [vpekki ... [namskeiðið]]  
*many students-D liked not the course*  
 "Many students didn't like the course"
- b) Morgum stúdentum líkaði [namskeiðið] [vpekki ... t ]  
  
*many students-D liked the course-N not*  
 "Many students didn't like the course"

The adverbial negation marker *ekki* is analyzed as adjoined to the left edge of the VP and is thus a convenient diagnostic for movement out of it. Note that the object here is marked nominative; nominative objects behave exactly like accusative objects in this respect.

On the analysis of clause structure presented here, however, some portion of this analysis must be erroneous. On our system, English object AgrPs are positioned below the position of base-generation of the subject—no movement of objects past the position of base-generation of the subject will be necessary for case-checking. There are three possibilities in accounting for the OS phenomena. First, Icelandic and English AgrPs could be in different places—within the VP in English, outside it in Icelandic. Second, the VP to which *ekki* is adjoined in the diagram above could be, in our terms, the BaseP—the lower VP shell in Koizumi's analysis—and overt object shift is to the left of this position. Third, object shift movement could indeed cross the position of base-generation of the subject but such movement is not for case-checking purposes, and English and Icelandic are identical in checking their morphological case in AgrPs below the position of base-generation of the subject. I propose below that the last option, or a combination of the last two options, is the most likely.

### 5.2.2 *OS for case?*

OS movement is conditioned by the specificity of the object. Diesing (1993) argues that OS movement is motivated by a semantic requirement that the object get outside the nuclear scope of the clause. If that is the correct analysis of the motivation for OS, linking it to a case-checking position seems unmotivated—all object NPs will need to move to AgrO for case purposes at LF, whether definite or not, and semantic interpretation will take place from there; interpretation should not be conditional upon whether or not the object checked its case before Spell-Out. If indefinite objects do not shift beyond the position of base-generation of the subject before Spell-Out, it is reasonable to assume that they never do shift.

The other reason to assume that movement for case-checking is to a position within the VP — in our terms, within the EventP — in Icelandic as well as English is that Icelandic seems to exhibit the same type of adjacency effects with manner adverbial elements between non-raised verbs and their direct objects (in 12) below (Höskuldur Thráinsson, p.c.). Presumably, then, the account of adjacency assumed above for English should be extended to Icelandic.

12. a) \*Hann hefur lesið hratt/flj'ott kvaedið  
*he has read fast/quickly the poem*  
 “He has read quickly the poem”
- b) \*Hann hefur kennt nemendum flj'ott kvaedið  
*he has taught the students quickly the poem*  
 “He has taught the students quickly the poem”

Further, adverbs *can* occur between an overtly shifted indirect and direct object (two objects can overtly shift in Icelandic, although somewhat marginally):

13. ?Ég kenndi nemendum sennilega kvaedið alls ekki  
*I taught the students probably the poem not at all*  
 “I probably didn't teach the students the poem at all” (Collins and Thráinsson: 147)

On an account where the indirect object and the direct object have shifted for case reasons to two AgrP positions outside the BaseP (with *ekki* adjoined, marginally to BaseP), an adverbial will not be able to intervene between them<sup>4</sup>, as adverbials on our account cannot adjoin to AgrPs (which is how the ungrammaticality of 12b) above is derived). The legitimacy of the adverbial appearing between the two objects in 13) above suggests that the projections to which the object and indirect object are shifting are contentful, or at least that there is a contentful projection between their shifted positions. Thráinsson (p.c.) points out that only NPs can undergo OS in Icelandic; whatever the mechanism for deriving Object Shift turns out to be, it must be something that differentiates between NPs and PPs; further, it should be in some way contingent upon verb movement. Equidistance is an attractive way of capturing this condition; it is possible that the account

<sup>4</sup>On Collins and Thráinsson's (1993) analysis, there will be a TP between these two positions, to which it is possible these adverbials might adjoin.

proposed in Bures, Bobaljik and Jonas, etc. is still the correct one. Crucially, however, for the account here, such movement can not be related to case-checking at all (Bobaljik (1995) makes a more detailed proposal along these lines).

### 5.2.3 *TEC+OS and dative-nominative constructions*

Let us return briefly to the question of the object status of the nominative argument in dative-nominative constructions, given the account outlined in the previous chapter. As we saw above, nominative objects can shift overtly, appearing in some position outside the VP/EventP. Given that they can get that far up in the tree (that is, outside EventP), an advocate of the notion that nominative case must be always be checked in Spec-TP might maintain that they can get as far as Spec-TP and check their nominative there, despite the negative polarity item and finiteness facts discussed in the previous chapter. There is evidence, however, that although OS movement is possible for nominative objects in Icelandic, the dative subject must pass through Spec-TP itself. If Spec-TP is occupied by the dative subject, the nominative object could not move to Spec-TP at LF, as this position would contain the trace of the dative subject.

The evidence that the dative argument passes through Spec-TP comes from the Transitive Expletive Construction facts in combination with the Object Shift facts discussed at length in Jonas and Bobaljik (1993) and Bobaljik and Jonas (forthcoming). In diagrams below, I will notate the functional projection above EventP to which OS occurs as “OSP”, remaining agnostic about its content and function.

Jonas and Bobaljik point out that given the Minimalist economy principles of Shortest Move and Equidistance, which constrain Leapfrogging, movement of the object to

OSP forces movement of the subject to SpecTP before it can move higher in the clause.

The derivation is seen in 14):

14.

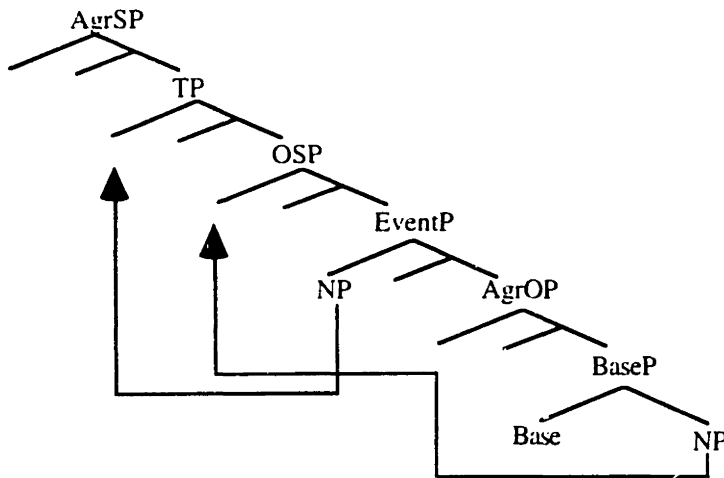

Shortest Move and Equidistance combine to force A-moving NPs to skip at most one specifier at a time. If both object and the EventP-internal subject are moving to higher functional projections before Spell-Out, the object skips the subject in Spec-VP and moves to Spec-OS; the subject can then skip Spec-OS and move to Spec-TP. (The heads of these XPs are successive-cyclically head-moving upwards while this is happening, expanding the domain for the application of Equidistance). The possibility of overt object shift must thus be correlated with both overt verb raising and the availability of Spec-TP as a landing site cross-linguistically.

Jonas and Bobaljik show that the subject can remain in Spec-TP at SPELL-OUT. Icelandic has a construction termed the Transitive Expletive Construction (TEC)<sup>5</sup>, in which an indefinite subject can follow the finite verb, while the normal subject position is occupied by an expletive. The subject has moved out of the EventP, as is shown by its position left of *ekki*. It has moved to at least the second functional projection beyond

<sup>5</sup>These constructions (TEC + OS) are somewhat marginal. There is a definite contrast with constructions where the subject appears after the object and before the adverbial, however. See Jonas and Bobaljik (1993) and references cited therein for discussion.

EventP, as J&B show that when a TEC construction is combined with an object-shift construction, the subject appears to the left of the object, which in turn is to the left of EventP-adjoined *ekki*. This can be seen in 15):

15. Það borðuðu [TPmargir strákar [OSPþjúgun [EÞekki ...]]  
*there ate many boys-N the sausages-A not*  
 “Many boys didn’t eat the sausages” (Jonas and Bobaljik (1993))

Crucially, this identical construction is possible with experiencer subject verbs, as you can see in 16), with movement diagrammed in 17)<sup>6</sup>:

- 16) Það líkaði [TPmorgum stúdentum [AgrOPetta namskeið [VÞekki ...]]  
*there liked many students-D this course-N not*  
 “Many students didn’t like this course”

17)

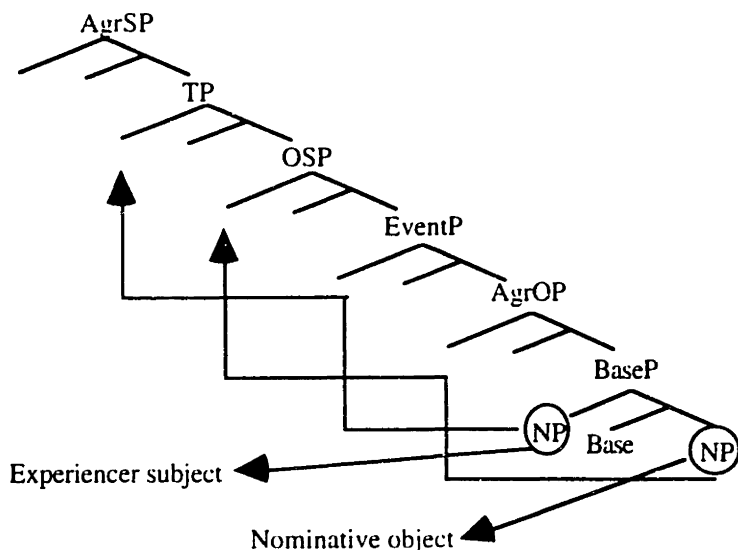

Experiencer-subject constructions have many properties in common with unaccusative and other derived-subject verbs (as shown for Italian by Belletti and Rizzi (1988) and for Icelandic by Sigurðsson (1989)). As suggested above, I assume that an EventP headed by a BE head dominating a prepositional BaseP captures this pattern. The movements of the arguments are exactly the same as for standard transitives after the first movement of the experiencer subject to the specifier of the EventP.

<sup>6</sup>Note that here the AgrOP is crucial in allowing movement of the nominative object out of the BaseP.

The subject in (17), appearing overtly in Spec-TP, must be checking some strong feature there, as must the object in Spec-OSP. The subject at LF is assumed to raise to move to adjoin to or substitute for the expletive (for now, assume the expletive is in Spec-AgrS, although we will see below that there are reasons to assume a higher, A' position for the expletive, corresponding to the position that triggers V2 in Icelandic in whose specifier Topics may appear (following Sigurðsson (1989)). Note that that substitution will leave the tail of an A-chain in Spec-TP. If the object were to raise to Spec-TP and check nominative there, it would have to adjoin to or substitute for the trace of the subject's A-chain; as things stand, this would be an illicit maneuver.

#### 5.2.4 *A Split-VP and Equidistance*

While we are in the process of considering these issues, it is worth stepping back for a moment to examine the status of movement conditions like Equidistance on this account. Bobaljik (1995) assumes a version of the split-VP hypothesis—the position of base-generation of the subject is above the position in which case-checking of the object occurs. For him, however, the subject is base-generated in Spec-TP, and overt object shift does not involve movement of the object over the base position of the subject. Equidistance, on that account, is not necessary.

On the account presented here, a different stacked configuration is adopted, in which object case-checking is internal to the EventP but the subject is generated below Spec-TP (for reasons outlined in Chapter 2 above). As noted above, Equidistance is still useful in deriving Holmberg's generalization on this type of account; the object must move outside of EventP and some principle allowing it to get past the position where the subject is generated is necessary. Even if the Holmberg's generalization facts should turn out to have nothing to do with Equidistance (an adjunction-to-EventP account, for instance, or

some such<sup>7</sup>), Equidistance is still necessary to account for the analysis of the double object construction in English presented in Chapter 3. Consider the movement necessary to check case overtly in double object constructions:

18.

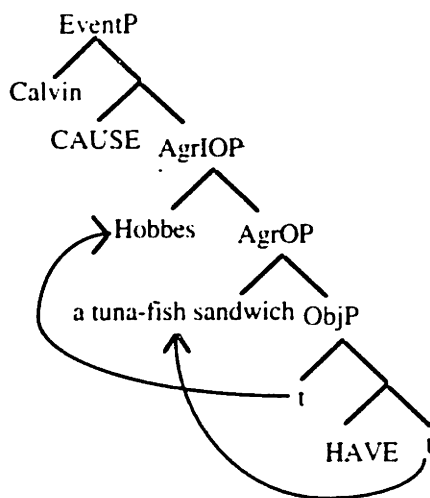

It can easily be seen that once the Theme argument has shifted to Spec-AgrO, a crossing-paths, Equidistance account of movement to Spec-AgrIO will be necessary to get the Goal/Location argument out of the BaseP, as the closest available A-position will be Spec-AgrO. Essentially, then, I am claiming that although objects and subjects do not necessarily cross paths in languages without overt OS like English, indirect objects and direct objects do cross paths<sup>8</sup>. Unfortunately, it is difficult to test for this type of movement relation. The ideal test would be the evidence from stranded Numeral Quantifiers in Japanese; presumably a stranded NQ associated with the indirect object should appear before a stranded NQ associated with the direct object. This test cannot be applied, however, as there seems to be a completely independent constraint on stranding floated

<sup>7</sup>Indeed, it seems to me that such an approach would be more consistent with the current analysis, as double object shift constructions will pose the problem for Equidistance discussed at length in Collins and Thráinsson (1993).

<sup>8</sup>The movement seen here might appear to be a problem for the notion of an "active" AgrP outlined in section 5.2.3 above; the direct object must move to an AgrP that is *inactive* (as it is c-commanded by the empty AgrIOP above it) before the indirect object can move to the active AgrIOP. The answer to this problem involves characterizing the notion of "active" so that it is relevant at LF, as discussed in fn. 3 above: if an NP finds itself in an *inactive* AgrP at LF, the derivation will crash. Movement to/through inactive AgrPs during the derivation will be perfectly well-formed, however, especially if the derivation would crash otherwise, as would be the case here.



NQs associated with a *ni*-marked NP. (Note that this is a constraint on *stranding* NQs; *floating* NQs out of a case-marked NP-*ni* is of course possible, and is diagnostic of prepositional vs. case-marker *ni* as discussed extensively above). In the absence of evidence to the contrary, however, I will assume that the Equidistance account of movement in double object and experiencer constructions is correct.

### 5.3 *PRO and the EPP*

So far, we have been assuming that the EPP, crucially connected to Tense, is located in the TP below AgrSP. [-finite] Tense has some requirement that the argument that fills it is not overt. It can be PRO, in control constructions. Recall from chapter 5 that PRO is an NP like any other, with respect to case—in Icelandic it can be shown that PRO receives whatever morphological case would have been assigned to an overt NP in the same sentence. Given this evidence, we assume that Control complement clauses are CPs, complete with their own AgrSP in which the PRO receives its morphological case. ECM and Raising complement clauses, however, will be TPs, without an AgrSP. Let us examine how the licensing mechanisms proposed above interact to generate the required structures.

#### 5.3.1 *Control vs. ECM revisited*

There is evidence from Icelandic that the two types of infinitive clauses differ, as first noted by Sigurðsson (1989). Among other things, in Icelandic, infinitival verbs raise out of the VP in control structures, but cannot in ECM or Raising structures. This can be seen in 19)-21) (recall that *ekki* marks the left edge of VP):

19. a) *María lofaði [að lesa ekki bókina]*  
*Mary promised to read not the book*  
 “Mary promised to not read the book.”

- b) \*María lofaði [að ekki lesa bókina]  
Mary promised to not read the book (Control)
20. a) \*Ég taldi [Maríu lesa ekki bókina]  
*I believed Mary read not the book*  
“I believed Mary to not have read the book”
- b) Ég taldi [Maríu ekki lesa bókina]  
*I believed [Mary not read the book]* (ECM)  
“I believed Mary to not have read the book”
21. a) \*María virtist [lesa ekki bókina]  
*Mary seemed read not the book*  
“Mary seemed to not read the book”
- b) María virtist [ekki lesa bókina]  
Mary seemed not read the book. (Raising)  
“*Mary seemed to not read the book*”  
(Sigurðsson (1989))

If overt verb movement is motivated by strong V-features on AgrS in Icelandic, the lack of movement in ECM and Raising constructions is explained if ECM and Raising infinitives do not contain AgrS, as noted by Watanabe (1993) It’s worth noting that another prediction of this analysis holds true; as noted by Watanabe (and references therein), if the verb is not raised overtly in ECM and Raising structures, overt Object Shift should not be possible (given Holmberg's generalization); however, it should be possible in Control structures. This is in fact the case (22):

22. María lofaði [að lesa bókina ekki]  
*Mary promised to read the book not*  
“Mary promised to not read the book.”

Control structures, then, are well-behaved on our analysis. A problem arises with respect to ECM cases, however. The embedded clause in ECM cases is [-finite], so the EPP in these instances requires PRO or (possibly) some other empty category; a trace, for instance. If the subject raises to the matrix AgrO or AgrS (in a Raising construction) for case licensing, a trace will be left in the embedded Spec-TP, which might be enough for the [-finite] EPP features. Presumably, however, PRO could also satisfy those features. What,

then, rules out an ECM structure involving raising a controlled PRO to the matrix AgrOP, as in 23) below?

23. \*Calvin believes [<sub>AgrOP</sub> PRO<sub>i</sub> [<sub>TP</sub> t<sub>i</sub> to like Hobbes]]  
 (meaning “Calvin believes himself to like Hobbes”).

There are several possible answers to this question. I will end up adopting what some might consider the least economical of these; there is some independent evidence for the proposal, however, and it is slightly less *ad hoc* than other possible accounts. Any account will have to incorporate the insight that there is some element present in Control structures that is not present in ECM structures that forces the appearance of PRO in one but disallows it in the other—on the account here, necessarily connected to the Extended Projection Principle. I propose that the element present in Control structures (and full clauses generally) is an A-bar position, above AgrS, which licenses or fails to license PRO—that is, it is the locus of finiteness and the EPP, another TP, which I will term TP1. It corresponds to the V2-triggering position. The TP below AgrSP will henceforth be TP2; for further speculation about its nature and content, see the discussion of Irish below. TP2 will be the complement to ECM and Raising verbs.

The architecture of articulated Infl will then appear as in 24) below:

24.

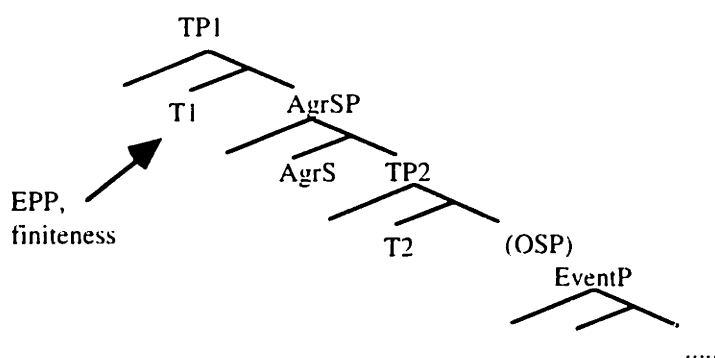

It is possible to imagine that the same effect could be achieved with a structure in which the canonical positions of TP (that is, TP2 in the above structure) and AgrSP are simply reversed (as in Pollock (1989)). There are a couple of reasons to prefer the structure in 36) above to the more reduced version, however. First, if there were no second TP in

the clause, external to EventP, the complement to ECM and Raising verbs would have to be EventP or AgrSP. It does happen that some ECM verbs do take EventP complements (“Calvin made Hobbes eat a tunafish sandwich”), but others clearly take a larger complement (“Calvin believed Hobbes to have eaten a tunafish sandwich”) which yet has to disallow the appearance of PRO (“\*Calvin believed PRO to have eaten a tunafish sandwich”). Claiming that the complement to an ECM verb is AgrSP seems unpalatable as adverbial elements can adjoin to the complement of an ECM verb (“Calvin forced Hobbes never to eat a tuna-fish sandwich”) which on the account here indicates that said complement cannot be an AgrP. Hence, the standard TP is in reality TP2, and there is another projection above AgrSP, TP1, which encodes finiteness.

This position has been argued for independently with respect to finite clauses by Branigan (1992), among others. Branigan motivates this projection to account for the A-bar properties of subjects noted for Yiddish by Diesing (1990); he extends the account to subjects in Dutch and English. Jonas (1993) also argues that subjects in Icelandic are in an A-bar position, and Siggurðsson (1989) and Vikner (1991) argue that Icelandic expletives show A-bar properties. In a transitive expletive construction, then, the expletive will be in Spec-TP1 (not Spec-AgrSP), the verb in Spec-AgrS and the subject in Spec-TP2. This position could also conceivably be relevant to phenomena for which recursive CPs have been proposed, for example, embedded V2 phenomena. I’ll refer you to Branigan for extensive argumentation for this projection, and to Richards (1995) for discussion of its identity with TopicP in Tagalog and Icelandic, and just sketch a brief argument from Irish for it here.

### 5.3.2 Irish and the EPP

If accounting for the effects of the EPP merely involves positing more features on more functional projections to be checked before Spell-Out, presumably one would expect the possibility that those features could be weak—that is, that they needn't be checked before Spell-Out. If in fact movement to these subject positions is universally attested, it would be more satisfying to derive it from deeper principles. Interestingly, however, weak EPP features seem to be attested in Irish. McCloskey (1994) has proposed just this restriction to account for a large range of facts about Irish unaccusatives. His proposed structure has the finite verb in AgrS and the subject in SpecTP (giving the Irish VSO order). The structure proposed above is consistent with his conclusions, and I would like to suggest the addition of TP1 to the exploded Infl would capture some additional Irish facts.

Andrew Carnie (p.c.) points out that there is morphological evidence for two TPs in Irish, as well. In 25), it can be seen that there is a perfective aspectual particle *tareis* between the subject and the overtly shifted object.

25. [TP<sub>1</sub>Tá [AgrP<sub>1</sub>Calbhín [TP<sub>2</sub>tareis [OSP Hobbes [OS a [VPbhuaíl...]]]]]]  
*Be.pres Calvin after Hobbes obj.agr hit*  
 “Calvin has just hit Hobbes”

If aspect is marked in Irish in TP<sub>2</sub>, it seems natural to assume that tense is marked in TP<sub>1</sub>, where the finite verb shows up (and, recall, where [+/-overt] is conditioned, depending on finiteness). A four-projection Infl structure like that outlined above provides a neat slot for each of these elements to appear in. For much more extensive discussion, see Carnie (1995).<sup>9</sup>

---

<sup>9</sup>One difference between Carnie's analysis and that presented here is that the OSP here is a case-checking AgrP on his analysis (along the lines of Chomsky (1992) sketched earlier).

## 5.4 *Auxiliaries, Undercover Agents and Other Psychological Problems*

There are a number of questions and unresolved issues which have not so far been discussed. In this section, we look at some of them; solutions in many cases will continue to be elusive, but some attempt at defining and describing the problems is made. First, we will briefly discuss some consequences of the preliminary analysis of participles and their relation to auxiliaries presented in Chapter 3 above, briefly revisiting the lexical syntax of transitive verbs. We then turn to the question of HAVE and psychological predicates. Noonan (1993) concludes that the status of Irish as a HAVE-no. language explains some peculiarities of psychological predicate constructions in that language; the question of whether or not her analysis can be extended to the other HAVE-not languages examined in Chapter 3 above is briefly discussed.

### 5.4.1 *Mandatory agents and transitive verbs*

Given the structural nature of the interpretation of the Event head, it would seem that there should be complete optionality in the realization of a given predicate — every agentive verb should have an unaccusative counterpart, and vice versa. That is, it appears to be a problem that a verb like “shelve” in (13) below doesn't have a raising counterpart, giving “The book shelved”.

26.

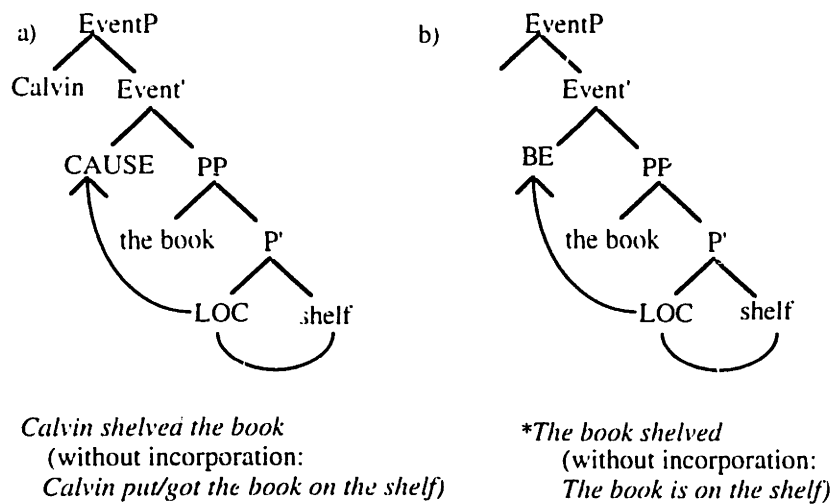

It seems to be the case that this is problematic only for agentive verbs whose underlying representation has a prepositional complement to Event<sup>10</sup>. Adjectival complements allow transitive/inchoative alternations (“The sun melted the ice”/“The ice melted”), as do nominal complements (although it is not usually conceived of in this way): “John raced”/“A race happened”. With English active transitive verbs, however, any alternation which allows them to be external-argumentless verbs must be marked in some way, either by passive morphology (“These books were shelved”/“These books got shelved”) or by using a middle construction (“These books shelve easily<sup>11</sup>”). There thus seems to be a sense in which the “default” form of these verbs involves some notion of causation, as both of these constructions contain the notion of an “implicit agent”. The class of transitive verbs which have such an agent (that is, a non-optional one) is very large, including, for instance, all verbs of contact: *push*, *kick*, *kiss*... No account of the lack of optionality of the agent in these verbs suggests itself at the moment; however, it is clear on this account that this type of verb must have as part of its l-syntax a CAUSE event head: any verb with a true agent/causer argument must have such a head.

<sup>10</sup>modulo verbs like “destroy” as noted in chapter 3 above; it seems to me, however, that the problem with these verbs is of a different type.

<sup>11</sup>As noted in Chapter 3, the class of adverbs which allow middle constructions is exactly that which adjoins to the embedded BaseP, modifying the manner in which the event is accomplished.

This type of verb has another associated problem, which is that its correct representation in I-syntax is not obvious. At a minimum, it must have an external argument and a CAUSE Event head. It seems likely that the BaseP which is associated with it is prepositional, being a relation between the object of the verb and some nominal like “a push” or “a kiss”. However, the most straightforward representation of this relation cannot be correct: if “Calvin hit Hobbes” is equivalent to “Calvin gave Hobbes a hit” (i.e. [Calvin CAUSE Hobbes HAVE hit]), we predict that HAVE-not languages should not have simple transitives, which is self-evidently incorrect. Further, as noted in Levin (1993), the objects of this class of verb are not necessarily affected objects (something kicked is not necessarily affected by the kick), while the objects of, for instance, the “break” class (which undergoes the inchoative/causative alternation, and does not have a prepositional/relational BaseP<sup>12</sup> but rather an adjectival one) are indeed necessarily affected. Recall also that in the discussion of the *give* double object/double complement alternation it was the element in the specifier of BaseP— “Hobbes”, above—which was necessarily an affected object. Finally, the “contact” verbs undergo the well-known alternation in 27) below, which affects the possibility of participation in a resultative construction:

27. a) Hobbes kicked the door (down).  
 b) Hobbes kicked at the door (\*down)

It is clear that while one might imagine the underlying structure [Hobbes CAUSE door HAVE kick] for the verb in 27a), with incorporation of the nominal “kick”, such a structure is not possible for 27b), as the prepositional phrase “at the door” could not be an affected object in the specifier of BaseP. Similarly, however, the structure [Hobbes CAUSE kick LOC(at) the door] is not possible either, as elements in the specifier of BaseP cannot conflate to form verbs due to the ECP, as discussed in Hale and Keyser (1991). We

---

<sup>12</sup>Hale and Keyser (1991) essentially suggest that the distinction between relational and non-relational BasePs is the crucial one governing the distribution of inchoative formation, although their terminology is different and they do not discuss transitives such as “hit” specifically as relational verbs.



leave the question of the I-syntax of this type of verb for the moment<sup>13</sup>, noting it as a problem, and move on to passive and perfective participles and the various realizations of HAVE+Event.

#### 5.4.2 *Implicit agents and causative and auxiliary HAVE*

As mentioned in passing above, verbal passives and middles evince the phenomenon known as the “implicit agent”, whereby the suppressed agent of the construction can make its syntactic presence felt. The simplest assumption to make with respect to this phenomenon is that the agent argument is in fact present in the verbal passive, conceivably as an empty category. If this is the case, the structure of a passive participle would be like that in 28) below, where the PRO<sup>14</sup> is the unexpressed agent:

28.

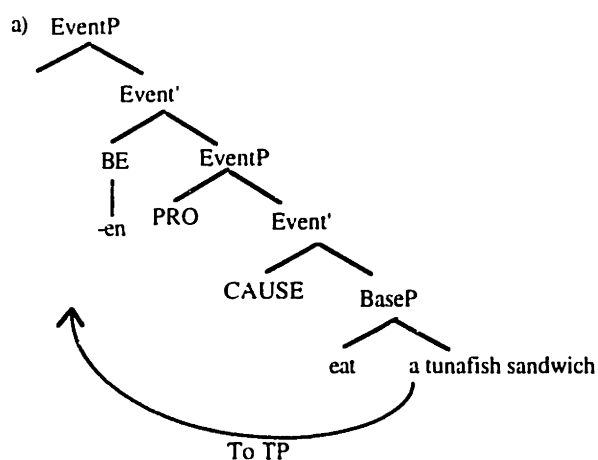

Evidently, at this point we have entered the realm of speculation. Imagine, however, that this is the correct structure for passive participles, and imagine further that passive and perfective participles have the same structure. Here we have the empty argument which will be bound by the argument introduced by HAVE in the perfective,

<sup>13</sup>Along with the I-syntax of many of the verb classes of English not mentioned here.

<sup>14</sup>PRO here is used as a convenient catch-all empty category; its properties, however, cannot be the same as those of the PRO in Control structures, as this empty category has nothing to do with finiteness or the EPP, and the reader is cautioned as to its distinct status

giving the correct interpretation of the verb. The question that then arises is why perfectives of unaccusatives take the HAVE auxiliary in English, as there is no Causer argument to be PRO in those cases (no problem arises with the unaccusatives which take BE in, e.g. Romance). There are at least two possible for answers to that question, each of which has its attendant problems; the second, however, seems the most promising at this point, for reasons to be spelled out.

29.

- a) The argument of the unaccusative is realized as PRO, just as is the external argument of agentive verbs, and is controlled by a projected argument of HAVE in the same way. It seems to me that this approach would be difficult to pursue in the Romance languages, where perfectives of unaccusatives take BE as the auxiliary; further, it makes the prediction that there should be impersonal passives of unaccusative verbs in languages that allow impersonal passives, which is usually not the case.
- b) The auxiliary used in English, as in Romance languages, for the perfective of unaccusatives is in fact a pure BE Event head with no HAVE complement; it is an accident of morphology that it is realized as “have” overtly. The embedded argument of the unaccusative raises to subject position, as in passives, giving “Calvin has arrived”.

The reason that option B is appealing is that we have already posited similar homophony between a BE Event head with a HAVE complement and a CAUSE Event head with a HAVE complement; not quite a parallel case, but similar enough to be suggestive. The discussion I am referring to, of course, is the case of the experiencer and causative readings of “have”, one of which has a CAUSE Event head (the causative “have”) and one of which has a BE Event head (the experiencer “have”) which takes a HAVE complement which in turn takes an embedded EventP as a complement (see the structures in Chapter 3, example 83)). Further, it seems likely that the experiencer “have” construction has the same structure as the Japanese “adversative passive”, in which the top BE Event head is realized as the passive morpheme *-rare-*, yet whose interpretation (and, I posit, structure) is essentially identical to that of the experiencer “have” construction (see the sample structure in 30) below, where the intended reading is “Opus was adversely affected by Rosebud eating pizza”). It is therefore clear that there can be some mismatch, cross-linguistically, in

what forms show up in particular environments, despite identical underlying structures<sup>15</sup>. It is not unreasonable to suppose, therefore, that a “BE” auxiliary Event head could surface as “have” in a given environment.

30.

a) Experiencer “have”

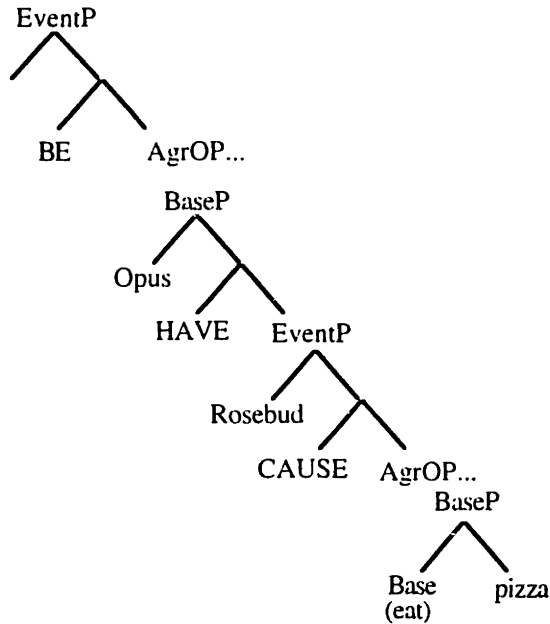

Opus had Rosebud eat pizza (on him)

b) “Adversative” Passive

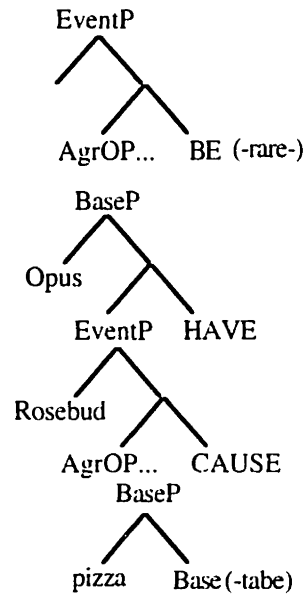

Opus-ga Rosebud-ni pizza-o tabe-rare-ta  
Opus-N Rosebud-D Pizza-A eat-Passive-Pst  
“Opus had Rosebud eat pizza (on him)”

It is to be emphasized (and is no doubt obvious) that these structures and comments are in no way intended as anything other than preliminary remarks and suggestions. A complete analysis of passives and perfectives is beyond the scope of this chapter.

### 5.4.3 HAVE and dative-nominative constructions diachronically

We now turn to other possible implications of our proposed Base primitive relation HAVE. As noted briefly in Chapter 3, the phenomenon of quirky dative on the subject of

<sup>15</sup>Note also that, as suggested earlier, it is possible that causative “have” in English has the same structure as the “let” passive in Japanese (Chapter 4, fn. 14), in which case “have” in English would correspond to a morpheme realized as *-sase-* in Japanese, providing further support to the contention here that the surface realization of a given verb (particularly a “light” verb of this type) is not necessarily the best clue as to its structure.

psychological predicates, and agreement-triggering, apparently structural nominative on the object of such predicates, is far from uncommon. Abundant examples from Icelandic were given in Chapter 4; below are examples from Japanese and Kannada:

31. a) Japanese<sup>16</sup>  
 Yamada-sensei-ni sono gakusei-ga o-wakari-ni-nar-ana-katta  
*Yamada-Prof-D t that student-N understand-Hon-Neg-Past*  
 “Professor Yamada didn't understand that student.”
- b) Kannada<sup>17</sup>  
 So'manige a'nu tumba ishta  
*Soma-D self-N much liking*  
 “Soma is very fond of himself”

This dative-nominative pattern is strikingly similar to the dative-nominative pattern found in the possessives of many languages, in particular Georgian and Japanese discussed in Chapter 3. In all of these cases, the nominative triggers (sometimes impoverished) agreement with the verb, while the dative argument behaves as a subject with respect to many of the language-particular structural tests which are not related to case and agreement properties.

If this similarity is not coincidental, one expects that some property of psychological predicates is related to the realization of the possessive—that is, that perhaps psychological predicates in at least some languages involve the prepositional element HAVE. This is clearly true in languages like French, for instance, where some psychological states are nominals, expressed as possessed of the subject, using possessive *avoir*; consider the examples in 32):

32. a) Tintin a faim  
 Tintin has hunger  
 “Tintin is hungry”, “Tintin hungers.”
- b) Tintin a peur (de q.q.ch.)  
 Tintin has fear (of sthg...)  
 “Tintin fears ..”, “Tintin is afraid of..”

<sup>16</sup>Subject honorification agreeing with the Dative argument here is a partial demonstration of its subjecthood; for other tests, see the Appendix to this chapter.

<sup>17</sup>The dative argument here can antecede a subject-oriented reflexive in the nominative argument; again, see the Appendix for other tests for subjecthood of the dative element.

5.4.3.1 *Irish psychological predicates*

If psych predicates do contain the preposition HAVE, the prediction is made that in some sense, languages without HAVE should have periphrastic or otherwise marked ways of representing psychological predicates. It would be interesting, then, to examine the representation of psychological states in a language which doesn't have the preposition HAVE, as outlined in Chapter 3. Noonan (1993) proposes an account for the structures of psychological states in Irish using essentially the insight from Chapter 3: Irish has no predicate *have*. For Noonan, *have* is a verb in its own right, whose subject is an external argument, rather than a combination of a light verb BE plus a prepositional element, however, the insight is essentially similar. Consider the expression of psychological states in the examples in 33) below (recall that the basic word order of Irish is VSO):

33. a) Tá gaeilge ag Fliodhais  
*Be Irish at Fliodhas*  
 “Fliodhais knows Irish.”
- b) Tá eagla roimh an bpúca ag Ailill  
*BE fear before the Puca at Ailill*  
 “Ailill fears the Puca.”
- c) Tá meas ar Meadhbh ag Ailill  
*BE respect on Meadhbh at Ailill*  
 “Ailill respects Meadhbh” (Noonan (1993):1-2)

Compare the word order in 33) with an example of a possessive sentence below in 34) (repeated from section 3.2.5.5.1):

34. Tá peann ag Máire  
*BE pen at Mary*  
 “Mary has a pen”.

Note that the order of arguments which expresses the relation between the state and the experiencer of that state is identical to that which expresses the relation between the item owned and the owner; the state and the thing owned are in subject position, while the

experiencer and the owner are in prepositional phrases in object position. The cases appear to be exactly parallel.

Noonan proposes to account for the two cases in the same way, associating both with the lack of a predicate *have* in Irish. In our terms, this would entail that psychological states in languages with HAVE are expressed underlyingly as possession relations, with the ordering [Goal/Possessor/Holder HAVE Theme], as diagrammed in 35a), and that languages without HAVE like Irish, psychological states are expressed in the (default?) [Theme LOC Goal/Possessor/Holder]<sup>18</sup> ordering as seen in 35b):

35.

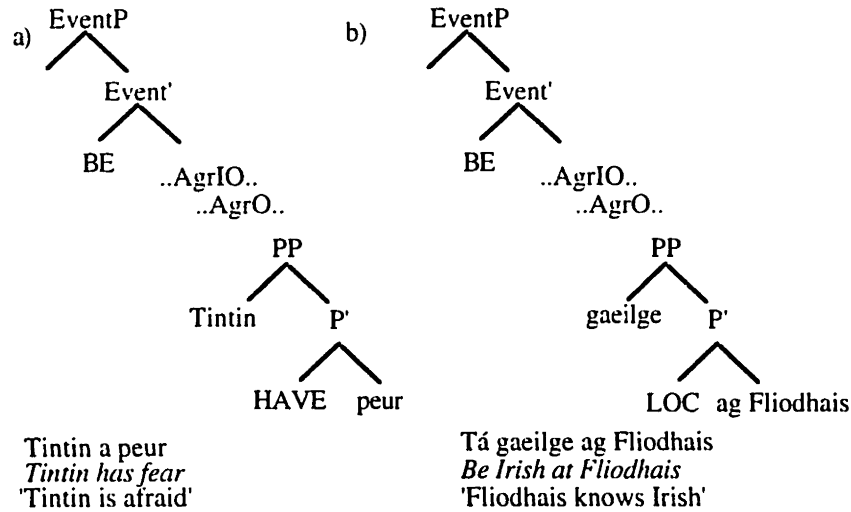

#### 5.4.3.2 Psych predicates in other HAVE-not languages

Irish thus seems to be a particularly transparent instance of this type of language, for which the extension of HAVE to an account of psychological predicates seems extremely natural. The other two HAVE-not languages we investigate, however, are not quite so well-behaved with respect to this prediction.

<sup>18</sup>Recall that HAVE and LOC are notational representations for two different relational heads; clearly little, if any, connection with everyday notions of possession or location are implied by this usage.

5.4.3.2.1 Diné: “subject-verb” idioms<sup>19</sup>

Diné and related languages tend to express this type of psychological/experiential state using apparently straightforward transitive verbs like “kill”—lit., “Hunger kills me (=I am hungry)”, “Sleep kills me (=I am sleepy)”. Examples from Slave can be seen in 36) below, from Rice and Saxon (1994):176.

36. a)      mbeh    sɛdhɛhxj  
               *sleep 1sgO.pf.kill*  
               “I am sleepy” (lit. “Sleep killed me”)
- b)      whɛkɔ            ʔanɪhwɛ  
               *fever 2sgO.pf.affect*  
               “You (sg) have a fever” (lit. “Fever affected you”).

Such examples appear *prima facie* to be problematic for the account of non-compositionality assumed above—that is, they appear to be subject-verb idioms, as *kill* is at first glance a transitive, agentive verb *par excellence*. Further, the experiencer is not conveniently marked with a prepositional phrase, as in the possessive construction. I would like to suggest, however, that what is crucial here is not the verb stem *kill*, but the ordering of arguments, in which respect Diné conforms to the prediction above; the subject is the psychological state and the experiencer/goal/location argument is the object. This suggests an underlying structure for these sentences like that proposed for Irish above. The verb *kill* in 36a) on this hypothesis is not the agentive form; the Event head in these sentences must be “be”, and “kill” here really has an “affect” meaning; “sleep affects me”, as is the case in 36b)<sup>20</sup>. On this treatment, of course, these are not “idioms” at all, and do not challenge the generalization made by Marantz in Chapter 3 with respect to external argument-verb idioms.

Rice and Saxon (1994:177) point out an interesting option for the realization of the experiencer object in these psychological idioms: the experiencer can be realized as a

<sup>19</sup>Thanks to Leslie Saxon for discussion and help with the facts below.

<sup>20</sup>Another possible paraphrase is “happens” or “be”: *sleep happens to me, sleepiness is on me*, which intuitively seems plausible if, as argued here, the verb contains a “BE” Event head.

regular pronominal inflectional form (*m-* in 37a) below), or alternatively as the disjoint anaphor, *zh-*, in 37b).

37. a)    *tʰəkoni*        *ʔameuleh*  
          fever            3O.opt.affect  
          “S/he might get a fever” (lit. “Fever might affect him/her”)
- b)    *tʰəkoni*        *ʔazhuleh*  
          fever            3O.opt.affect  
          “S/he might get a fever” (lit. “Fever might affect him/her”).

On their account, the anaphoric realization of the pronominal inflection is only possible when the subject and object of a transitive phrase are in a relation of mutual *m*-command (for them, when a subject is VP internal, this requirement is met). On the account here, however, *agentive* subjects—true external arguments—will never be in a relation of mutual *m*-command with objects, either direct or indirect. That relation will only occur between arguments generated in the specifier or complement of BaseP, again, limiting instances of apparent “subject-verb” idioms to non-*agentive* constructions. Further evidence for this special interpretation of Diné *kill* and other transitive verbs in these constructions is left for future research.

#### 5.4.3.2.2 Tagalog: a psychological problem

Tagalog, a HAVE-not language in our terms, has elements which appear to be psychological verbs of precisely the type not found in Irish. If these verbs are derived via incorporation of a state nominal into a prepositional head, (as later proposed for English, see 43) below), Tagalog should be a language with HAVE.

It is possible that what we really need to say is that a language might have a HAVE preposition and yet not use it to express possession or double object constructions—e.g., it might be going through a process of losing or acquiring HAVE. For instance, Diné has a verb meaning roughly “hold” or “keep” which is used to express Freeze's Locative



construction, with a Location subject and Theme object—exactly the configuration we argue is diagnostic of an underlying HAVE. Yet it is very clear that this configuration is not used to express possession. If this is the case, however, we lose the correlation that motivated the analysis of double object constructions as CAUSE x HAVE y to start with—there would be no prediction that a lack of possessive HAVE should correlate with a lack of double object constructions, as one could expect it to be used in one environment, but not another. Another solution, then, would be preferable.

One possibility that springs to mind is that psychological states are not underlying nouns in all languages. Hale (1995) argues that mapping of categories onto the basic syntactic configurations (section 3.2.4 in Chapter 3) is subject to inter- and intra-linguistic variation. If, for instance, psychological states were realized as underlying adjectives in Tagalog—that is, could only occur in an environment with a complement—they could incorporate into the BE Event head and behave as verbs even though the language is without the HAVE preposition. This appears to be superficially true: psych verbs are formed on adjectival roots, as seen in 38) below:

38. Matatakot      si Ikabod      sa pusa  
*AT-is-afraid*    *Ikabod*      *cat*  
 ‘Ikabod is afraid of cats’

The verb *matatakot* is formed via affixation of the verbal prefix *ma* (used mainly with unaccusative verbs, supporting at least the contention here that experiencer subjects are not true agentive external arguments) to the adjective *takot* meaning “afraid”.

Further, there is a glimmering of a suggestion that Tagalog psych predicates are significantly different from their English counterparts in at least one respect. Norvin Richards (p.c.) points out one unusual property Tagalog psych predicates seem to have: binding of an anaphoric subject experiencer by the object seems to be reasonably felicitous:

39. Gusto ng kanyang sarili si Amado  
*likes A his self T Amado*  
 “Himself likes Amado” (Cena (1994))

I will leave a detailed study of Tagalog psych predicates to future research.

#### 5.4.3.3 *Getting HAVE*

Now, consider the case of a HAVE-not language. How might it acquire the preposition HAVE? Such acquisition would involve reversing the order of the arguments in 35b). What could trigger this reversal?

A possible trigger could be found in the form of the Diné animacy hierarchy effects. Hale (1973) provides evidence that no matter what the thematic structure of a given verb, the animacy hierarchy forces syntactic movement to render the more animate argument more syntactically prominent—that is, if the most animate argument in a clause is not already the most syntactically prominent, movement (e.g. Inversion) must occur to render it so. These effects can be seen in the possessive construction, as outlined in Chapter 3, and repeated in example 40) below:

40. Diné    ǫ́íí'    b-ee            hóló  
      *man horse he-with exists*  
      “The man has a horse” (Lit. “The man, a horse is with him”)

The fact that inversion has occurred is marked in the argument position of the inverted phrase, in this case with the prefix *b-* in the prepositional phrase. This inversion will always be required in the possessive construction, as the possessor will always be more prominent on the animacy hierarchy than the thing possessed (possession of animates is expressed differently).

While most languages do not have an animacy hierarchy which is consistently and mandatorily reflected in the syntax, it is not unreasonable to suppose it is the case that there is a cross-linguistic preference for human/animate arguments to be prominent in discourse and hence represented prominently in the syntax. I speculate that this prominence could be

reflected in movement to some higher syntactic projection—for instance, Topic. If both Topics and subjects are on the left edge of a clause in a given language, it would be a short step for the learner to treat a Topic as a subject—that is, as base-generated in a higher position than the Theme argument, especially if there is no morphology to indicate otherwise. Once such reanalysis occurred, there would be no reason to continue to assume that the nominative argument was in subject position, especially if something like the Mechanical Case Parameter outlined in Chapter 4 is the correct analysis of the realization of morphological case. The nominative argument would be analyzed as originating in the lower position in the VP (that is, as the complement to a preposition), and a dative-nominative (or PP-nominative, as in Russian) system would result. The tendency, then, for psychological predicates and possessive constructions to have oblique-nominative case-marking patterns could result from the diachronic process of acquiring the preposition HAVE.

It is worth noting that the *-ni* marker on subjects in possessive and other dative-nominative patterns in Japanese is the (ad)positional *-ni* rather than the case-marker *-ni*, as shown by Sadakane and Koizumi (1995). Among other tests, they show that a numeral+classifier combination cannot be floated off of the subject of a possessor or a psych verb; this can be seen in 41):

41. \**gakusei-ni* 3-*nin* *Yamada-sensei-ga* *wakari-ta*  
*students-D* 3-*CL* *Prof. Yamada-N* *understand-Past*  
 “Three students understood Prof. Yamada.”

This is as predicted by the case realization principles outlined in the previous chapter, where case-marker *-ni* is dependent on two other structural case-markers being assigned in the same clause. The *-ni* here is “quirky”; it is possible that the real distinction between “quirky” and “structural” case is whether or not it was (at some historical point) assigned/realized by an underlying adposition. In Japanese, we have assumed that *-ni* can

actually be an adposition in its own right, heading a prepositional phrase; the other option is to assume that there is a null adpositional head which assigns *ni-* to the NP in its specifier.

#### 5.4.3.4 *Incorporation and psych predicates*

Now, consider the realization of psychological predicates as verbs in languages like English (in many languages, the attribution of psychological states can be paraphrased using several different constructions; three possibilities are shown for English below).

42. a) Calvin fears the weirdos from another planet.  
b) Calvin is afraid of the weirdos from another planet.  
c) Calvin has a deep-rooted fear of the weirdos from another planet.

Noonan (1993) proposes that psychological verbs like that in 10a) are the result of incorporation of the underlying nominal element denoting the psychological state into verbal HAVE, à la Hale and Keyser (1991), resulting in psych verbs like *fear*. This incorporation in our system would be the result of the complement to HAVE incorporating into the HAVE head and subsequent incorporation of that complex into the BE head above that. This is diagrammed in 43a) below. In 43b) we see a proposed structure for the adjectival representation of a psychological state, as in 42b), resulting from incomplete incorporation; the nominal has incorporated into the HAVE head, but the subsequent complex does not incorporate into the BE head, which is spelled out as *be*. Finally, the third possibility is represented in 43c), where incorporation of the HAVE prepositional head into the matrix BE results in verbal *have*, and the psychological state nominal is spelled out as an object.

43.

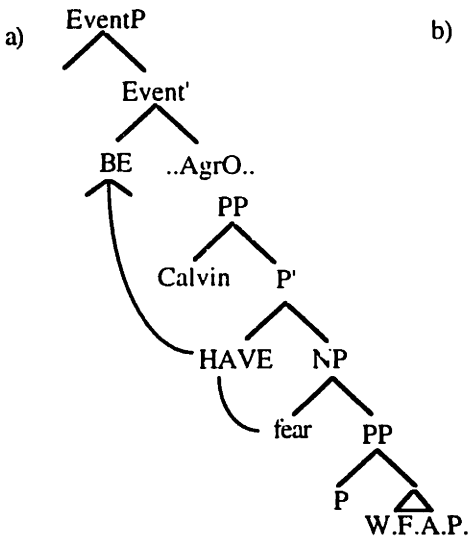

*Calvin fears (W.F.A.P.)*

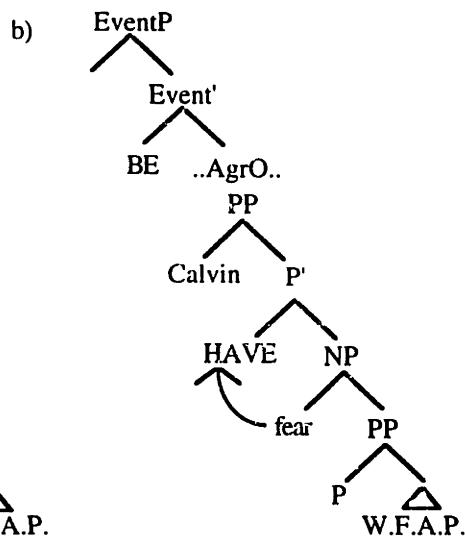

*Calvin is afraid (of W.F.A.P.)*

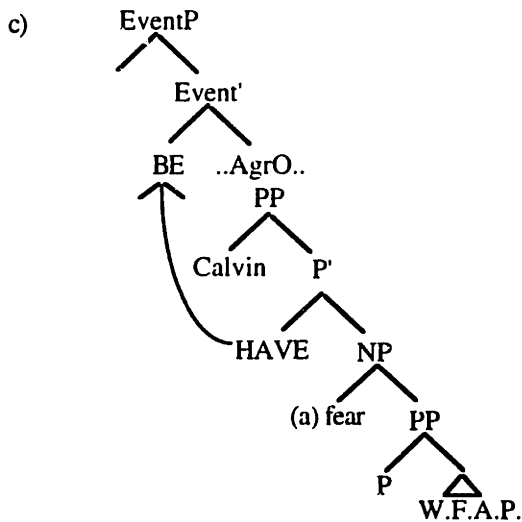

*Calvin has a deep-rooted fear (of W.F.A.P.)*

It is interesting to note that 43a), in which complete incorporation of both the object of HAVE and HAVE itself to the BE head has occurred, is the only case in which abstract accusative case is available to the object of the fear (which is otherwise realized as a prepositional complement to the adjective or the nominal psychological state). In particular, why should it be the case that partial incorporation (as in 43b)) does not result in the licensing of a direct object, while complete incorporation (as in 43a)) does? I have no account to offer of this phenomenon at the moment.

## 5.5 *Conclusion:*

In this chapter we have primarily fleshed out our account of case assignment and realization, with a couple of side excursions. The first was a discussion of restrictions on movement and the behavior of dative-nominative constructions with respect to object shift and TECs; the second a speculation about the provenance of quirky case, historically. For the rest, we examined the interaction of the MCP with the notion of abstract case, concluding that the effects of abstract case could be reduced to the Extended Projection Principle (after Marantz (1991)) and an assumption about how to determine what AgrPs in a given clause are “active”. We then examined the assumptions about the EPP which are necessary to account for the distribution of PRO in Control vs. ECM and Raising constructions, positing an A' position above AgrSP. This A' position will be responsible for Icelandic V2, and is identical to Tagalog “TopicP”, as argued in Richards (1995).

## Appendix to Chapter 5: *Subjecthood of dative experiencers cross-linguistically*

---

Below, I review the arguments presented in three papers dealing with very different languages against the most obvious competing hypothesis about dative-nominative experiencer subject constructions: that is, that the nominative Theme argument is really the subject and the dative Experiencer has been topicalized to a subject-looking position. I summarize the arguments and data from Zaenen et. al (1985) for Icelandic, Takezawa (1987) for Japanese, and Sridhar (1976) for Kannada. In all cases I use the terminology of the source; no attempt is made to update the analysis of any of these tests. This appendix is purely intended as a quick and easy summary of the relevant facts distinguishing the two possibilities.

*Competing hypothesis:* nominative nominal is the subject, dative-marked NP is actually a topicalized NP

## A.1 Icelandic (Zaenen et al., 1985)

### A.1.1 ECM constructions

Non-subjects cannot appear in the object position of ECM verbs, as shown by the contrast with the topicalized nominal in 2) below:

1. a) O'lafur er bo'ndi  
*Olaf-N is a farmer-N*
- b) Bo'ndi er O'lafur (topicalization)  
*a farmer-N is Olaf-N*
2. a) E'g tel O'laf vera bo'nda  
*I believe Olaf-A to be a farmer-A*
- b) \*E'g tel bo'nda vera O'laf  
*\*I believe a farmer-A t o be Olaf-A*

Dative-marked subjects can appear in this construction:

3. a) E'g tel konunginum hafa verið gefnar amba'ttir  
*I believe the king-D t o have been given-fpl slaves-N*
- b) E'g tel henni hafa alltaf tho'tt O'lafur leiðinlegur  
*I believe her-D to have always thought Olaf-N boring-N*

Simple embedded topicalization is possible in Icelandic (4), although not in binding domains (relative clauses, indirect questions, comparatives, etc), so the above examples indicate something about topicalization+ECM, not merely about embedded topicalization:

4. a) Mari'a telur að Jo'n hafi kysst Harald i'gaer  
*Mary-N believes that Jon-N has kissed Harold-A yesterday*
- b) Mari'a telur að Harald hafi Jo'n kysst i'gaer (topic.)  
*Mary-N believes that Harald-A has Jon-N kissed yesterday*

### A.1.2 Reflexivization

Icelandic has subject-oriented reflexives. Dative subjects can act as controllers for these anaphors, while nominative objects cannot.



5. **Konunginum** voru gefnar amba'ttir i' ho'll **sinni/?hennar**  
*he king-D were given-fpl slaves-N i n palace his-REFL-?PRON*

### A.1.3 Topicalization a.k.a. Subject-Verb Inversion

In Icelandic, topicalization forces “subject-verb inversion”—that is, the V2 constraint forces the subject to occur after the tensed verb. When one topicalization has taken place, no further topicalization is possible—i.e., only subjects can occur in the position immediately after the tensed verb. Dative subjects can occur in this position, with other topicalized NPs:

6. Um veturinn voru konunginum gefnar amba'ttir  
*in the-winter were t he king-D given-fpl slaves-N*

### A.1.4 Extraction

In Icelandic, topicalization is possible in embedded clauses, but not in an embedded clause that has had an element wh-moved out of it (7 a) and b)). Dative subjects, however, can occur in such embedded clauses, as shown in 8):

7. a) Hvenaer telur Mari'a að Jo'n hafi kysst Harald?  
*when believes Mary-N that Jon-N has kissed Harold-A*
- b) \*Hvenaer telur Mari'a að Harald hafi Jo'n kysst?  
*\*when believes Mary-N that Harold-A has Jon-N kissed?*
8. Hvaða amba'ttir heldur thu' að konunginum verði gefnar  
*which slaves-N think you that the king-D will-be given*

### A.1.5 Transitive Expletive Constructions

In Icelandic, indefinite subjects can occur after the tensed verb with an expletive “there” preceding the tensed verb (9 b)). Topicalized NPs cannot occur after the tensed verb in this construction (9a)):

9. a) \**thað* hefur hjo'li thjo'furinn stolið  
       \**there* has a bicycle-D the thief-N stolen  
       b) *thað* voru konungi gefnar amba'ttir i vetur  
       *there* was a king-D given slaves-N in winter

### A.1.6 Subject Ellipsis

Only subjects can be deleted under identity with a subject in a preceding conjoined phrase in modern Icelandic. Dative-marked subjects can so delete; nominative marked objects cannot:

10. a) Hann segist vera duglegur, en \_\_\_ finnst verkefnið  
       *He-N* says-self to be diligent, but \_\_\_-D finds the homework-N  
       of thungt  
       *too hard*  
       “He says he is diligent, but (he) finds the homework too hard”  
       b) \*Hann segist vera duglegur, en me'r finnst \_\_\_ latur  
       \**he* says-self to be diligent, but I-D find \_\_\_-N lazy  
       “He says he is diligent, but I find (him) lazy”

### A.1.7 Infinitive Complements

Only subjects can be PRO in infinitive clauses, whether controlled or arbitrary. Dative subjects are able to be PRO in Icelandic:

11. Að vera gefnar amba'ttir var mikill heiður  
       *To be given slaves* was great honor

## A.2 Japanese (Takezawa 1987)

### A.2.1 Reflexivization

The reflexive pronoun “zibun” in Japanese is strongly subject-oriented; no coreference with objects is typically possible (12a) and b)). Coreference with dative-marked subjects is possible, coreference with nominative-marked objects is not (13).

12. a) **John-ga** okusan-o **zibun-no** oya-no mae-de sikat-ta  
*John-N wife-A self-G parents-G in-front-of scold-Pst*  
 “John scolded (his) wife in front of self’s parents.”

b) \***John-ga** **okusan-o** **zisin-no** oya-no mae-de sikat-ta  
 \**John-N wife-A self-G parents-G in-front-of scold-Pst*  
 “John scolded (his) wife in front of self’s parents.”

13.

a) **John-ni** okusan-ga **zibun-no** oya-no mae-de sikar-e-na-i  
*John-D wife-N self-G parents-G in-front-of scold-pot-neg-pres*  
 “John can’t scold (his) wife in front of self’s parents”

b) **John-ni** **okusan-ga** **zibun-no** oya-no mae-de sikar-e-na-i  
*John-D wife-N self-G parents-G in-front-of scold-pot-neg-pres*  
 “John can’t scold (his) wife in front of self’s parents

### A.2.2 Subject-honorification

A type of verbal morphology indicating respect can appear only when the respected person is the subject of the sentence (14)). (Objects can induce honorific morphology on the verb, but the marking takes a different form). Dative subjects can induce such marking, while nominative objects cannot (15):

14. a) Yamada-sensei-ga sono gakusei-o o-maneki-ni-nat-ta  
*Yamada-Prof-N that student-A invited-Hon-Past*  
 “Professor Yamada invited that student”

b) \*Sono gakusei-ga Yamada-sensei-o o-maneki-ni-nat-ta  
 \**that student-N Yamada-Prof-A i nvited-Hon-Past*  
 “That student invited Professor Yamada”.

15. a) Yamada-sensei-ni sono gakusei-ga o-wakari-ni-nar-ana-katta  
*Yamada-Prof-D that student-N understand-Hon-Neg-Past*  
 “Professor Yamada didn't understand that student.”
- b) \*Sono gakusei-ni Yamada-sensei-ga o-wakari-ni-nar-ana-katta  
 \**that student-D Yamada-Prof-N understand-Hon-Neg-Past*  
 “That student didn't understand Professor Yamada”.

### A.2.3 Weak Crossover

Neutral word order in Japanese is SOV. If an OSV order is produced by scrambling when a pronoun in subject position is coindexed with an embedded NP in object position, the result is a standard WCO violation (16)). The same violation arises when the subject is marked dative and the object nominative, indicating that the dative NP is structurally higher than the object at DS (17)):

16. a) **John-no** sensei-ga **kare-o** syookaisi-ta (koto)  
*John-G t teacher-N he-A introduce-past*  
 “John's teacher introduced him”
- b) \*? **John-no** sensei-o **kare-ga** syookaisi-ta (koto)  
 \*? *John-G teacher-A he-N introduce-past*  
 “John's teacher, he introduced”
17. a) **Mary-no** hahaoya-ni **kanozyo-ga** ais-e-na-i (koto)  
*Mary-G mother-D she-N love-pot-neg-pres*  
 “Mary's mother cannot love her”
- b) \*? **Mary-no** hahaoya-ga **kanozyo-ni** ais-e-na-i (koto)  
 \*? *Mary-G mother-N she-D I ove-pot-neg-pres*  
 “Mary's mother, she cannot love.”

### A.2.4 Quantifier float

In Japanese, quantifiers can appear outside of the NP with which they are associated (18). Floated subject quantifiers can appear after the subject, but not after the subject and the object (“Sb. Qf. Ob.” is grammatical, while “\*Sb. Ob. Qf.” is not). Floated object quantifiers can appear both after the object, and if the object occurs in

sentence-initial position, after the subject. (“Sb. Ob. Of.” is all right, and so is “Ob. Sb. Qf”) A natural analysis involves the assumption that such ordering is derived from the object NP scrambling away from the floated quantifier. In O S Qf V sentences with dative subject/nom. object marking, if the nom. NP in initial position can be construed with a quantifier between the subject and the verb, such an analysis would imply that the object has shifted to that position from a DS position between the dative NP (the subject) and the verb, indicating that it occupies the same position as accusative-marked objects in nom-acc structures. This interpretation is in fact possible (19)

18. a) Sannin-no tyuunen-otoko-ga biiru-o nonde-i-ru  
*three-G middle-aged men-N beer-A drinking-pres.*  
 “Three middle aged men are drinking beer.” (unmarked order)
- b) Tyuunen-otoko-ga sannin biiru-o nonde-i-ru  
*middle-aged men-N three beer-A drinking-pres.*  
 “Three middle-aged men are drinking beer” (floated Q)
- c) \*Tyuunen-otoko-ga biiru-o sannin nonde-i-ru  
 \**middle-aged men-N beer-A three drinking-pres.*  
 “Three middle-aged men are drinking beer.”
- d) Mary-ga mittu-no tokei-o kurabe-ta  
*Mary-N three-G watch-A compare-past*  
 “Mary compared three watches.” (unmarked order)
- e) Mary-ga tokei-o mittu kurabe-ta  
*Mary-N watch-A three compared-past*  
 “Mary compared three watches” (floated Q)
- f) tokei-o Mary-ga mittu kurabe-ta  
*Watch-A Mary-N three compared-past*  
 “Mary compared three watches” (floated Q + scrambling)
19. a) Mary-ni mittu-no tigatta oto-ga kikoe-ta (koto)  
*Mary-D three-G different sounds-N heard-past*  
 “Mary heard three different sounds” (unmarked order)
- b) Tigatta oto-ga Mary-ni mittu kikoe-ta (koto)  
*different sounds-N Mary-D three heard-past*  
 “Mary heard three different sounds” (floated Q + scrambling)

Finally, in Japanese, quantifier scope judgments differ for unmarked word order vs. scrambled word order. In an unmarked sentence, a subject quantifier will always have wide scope over an object quantifier; if the object is scrambled to sentence-initial position,

it will optionally have wide scope—the sentence becomes ambiguous (20). Applying this generalization to dat-nom structures, if the nom-first ordering gives an ambiguous sentence with respect to quantifier scope, the ambiguity indicates that the nominative NP has scrambled to sentence-initial position from a location lower than that occupied by the dative subject. This is in fact the case

20. a) Sannin-no onna-ga hutari-no otoko-o seme-ta  
*three-G women-N two-G men-A criticized-past*  
 “Three women criticized two men” (unambiguous)
- b) Hutari-no otoko-o sannin-no onna-ga seme-ta  
*two-G men-A three-G women-N criticized-past*  
 “Two men, three women criticized” (ambiguous).
21. a) Sannin-no gakusei-ni hutatu-no gaikokugo-ga yom-e-ru  
*three-G students-D two foreign-G languages-N read-pot-poss*  
 “Three students can read two foreign languages” (unambiguous)
- b) Hutatu-no gaikokugo-ga sannin-no gakusei-ni yom-e-ru  
*two foreign-G languages-N three-G students-D read-pot-poss*  
 “Two foreign languages, three students can read” (ambiguous).

### A.3 Kannada (Sridhar, 1976)

#### A.3.1 Reflexivization

Kannada has subject-oriented reflexive pronouns which can only be anteceded by subjects; attempting to interpret them as anteceded by direct or indirect objects results in ungrammaticality (22)). Dative NPs in dat-nom constructions can serve as antecedents, while the nominative NP cannot (23)).

22. a) **Ja'n** Me'rige **tanna** ja'gavannu biTTukoTTanu  
*John Mary-D self's place-A gave*  
 “John gave up his own place for Mary”
- b)\*Ja'n **me'rige** **tanna** ja'gavannu biTTukoTTanu  
*\*John Mary-D self's place-A gave up*  
 “John gave her own place (back) to Mary”

c) \*Ja'n            **Me'riyannu**            **tanna** manege            karedukonDu ho'danu  
       \*John            Mary-A                        self's home-D            took  
 "John took Mary to her home"

23. a) **Mu'rtige**    **tanna** makkaLa            bagge tumba    abhima'na  
       Murti-D        self's kids                    of toward        much pride  
 "Murti is very proud of his kids"

b) So'manige    ta'nu                        tumba ishta  
       Soma-D        self-N                        much liking  
 "Soma is very fond of himself"

c) \*Tanage        so'manu                    tumba ishta  
       \*self-D        Soma-N                        much liking  
 "Soma is very fond of himself"

Note that changing the word order does not change the grammaticality of, for instance,

23b):

24.    Ta'nu            So'manige    tumba            ishta  
       self-N        Soma-D        much            liking  
 "Soma is very fond of himself."

### A.3.2 Coreferential Subject Deletion

In Kannada, sentences may be conjoined by making all finite verbs except the last one participles, and deleting all but one (the first or last) of the subjects, provided that the subjects are identical (25)). If their subjects are not identical, another strategy is employed to conjoin sentences. Both the controlling NP and the deleted NPs must be subjects; if one is not, ungrammaticality results (26)). Dative NPs in dat-nom constructions can be so deleted and can control such deletion (whatever the case of the coreferential NP); nominative object NPs cannot. (27), 28)).

25.    **Uma** angadige ho'gi Ø taraka'ri            tandu Ø adige            ma'DidaLu  
       Uma shop-to                        having-gone    vegetables having-brought    meal made.  
 "Uma, having gone to the shop and having brought vegetables, cooked the meal."

26. a) \*Ra'manu Ø karedu    **Shya'manu** hattira bandanu  
       \*Ramu having called Shyam                        near came  
 "Ramu having called (him), Shyam came near" (object deleted)

- b) \*a'ke **ku'liyava-nannu** karedu  $\emptyset$  sa'ma'nu iLisidanu  
*\*she porter-acc having called baggage put down (masc)*  
 “She having called the porter, (he) set the baggage down”  
 (object controlling)
27. a)  $\emptyset$  henDatiya jna'paka bandu **Ra'ma** vihvalana'danu  
*wife's remembrance having come Rama went berserk*  
 “Remembering his wife, Rama went berserk” (deletion of NP-D)
- b)  $\emptyset$  bisilinalli tirugi **Sure'shanige** ba'ya'rike a'yitu  
*sun-in having wandered Suresha-D thirst happened*  
 “Having wandered in the sun, Suresha became thirsty”  
 (NP-D controlling deletion).
28. a) \* $\emptyset$  nannannu cenna'gi ma'tana'Disi nanage **avaLu** ishTa a'daLu  
*\* I-A nicely having talked to I-D she-N liking became*  
 “She having talked to me nicely, I like her”  
 (NP-N controlling deletion)
- b) \***avaLu** nannannu cenna'gi ma'tana'Disi nanage  $\emptyset$  ishtTa a'daLu  
*She-N I-A nicely having talked to I-D I iking became*  
 “She having talked to me nicely, I like her”  
 (NP-N being deleted).



## 6 *Concluding Remarks*

---

Let me remind the reader of the questions with which we started in Chapter 1:

a) What are the different “sources” of subject properties—how can each of these properties be syntactically characterized?

b) Why, if these properties have separate provenance, do they exhibit such a strong tendency to converge on one “subject” NP, cross- and intra-linguistically?

In answer to the first question we have explored in depth two of the properties generally taken to characterize “subjects”, resulting in strong and detailed accounts of the notions “agency” and “causation” as they relate to subjects, as well as a serious proposal separating the question of licensing of subjects (the province of the Extended Projection Principle) from any notion of case-assignment or realization. Before summarizing these accounts, however, it behooves me to make a remark or two addressing the second question.

The simple answer, as far as questions of case and theta-roles are concerned, is that the structurally dominant argument at early stages in the derivation remains the structurally dominant argument. Locality restrictions on A-movement, in combination with the requirement that NPs must move to AgrPs for case-checking, will ensure that agent arguments, projected in the specifier of EventP, will move to a higher AgrP than arguments below EventP. If there is no agent argument, the next highest argument will reach the highest AgrP, *et cetera*. These restrictions account for the tendency, for example, for nominative case to be realized on the most “thematically prominent” NP, while still allowing such a correlation to be only a tendency, subject to disruption from quirky case and other factors, as extensively discussed in Chapters 4 and 5.

More complex is the question of why variation is allowed as to which argument reaches the EPP-satisfying A' position, Spec-TP1. By hypothesis, constructions like Locative Inversion, where a PP behaves with respect to *that*-trace effects like a “subject,” involve movement of the PP to that A' position where NP subjects find themselves. Similarly, if as suggested in Chapter 5, such an A' position is the one which triggers V2 phenomena, the question remains unanswered as to what parametric variation is necessary to force the highest NP to raise to that position in a “subject-prominent” language like English and yet allow almost any XP with Topic status to move to this same position in a “topic-prominent” language like, e.g., Tagalog. A possible candidate for such a parameter could be in varying the A vs. A' status of Spec-TP1, and hence varying the restrictions on movement into that position — certainly not a new solution, but not necessarily an easy one to implement either. Such questions, unfortunately, will have to be left to later research.

Let us return to the accounts of external arguments and case which have been the focus of the present investigation. The conclusion of the first half of the thesis is that agent arguments are generated in a separate projection from other arguments, projected by a head which can contribute the notion “CAUSE” to verbal meaning. The decomposition of verbs into two or more projections was initially motivated by syntactic and semantic arguments in

other work. First, we reviewed syntactic arguments (from recent accounts of Case Adjacency) which suggested that transitive verbs, at least, are the result of movement of a lower verbal head into a higher one. We then considered an account of the external/internal argument asymmetry proposed by Kratzer (1993), based on an observation of Marantz (1984), which relies crucially on generating external arguments in a projection distinct from that of internal arguments. The nature of the external-argument-projecting head, however, had not been fully addressed. We turned to Japanese lexical causatives to clarify this question. In particular, the fact that a lexical causative could only be formed on an unaccusative verbal root suggested that the causative morpheme was an overt reflex of the upper verbal projection argued for earlier, and that this upper verbal projection defined the boundaries of the “I-syntax”, in Hale and Keyser’s terms; this projection is responsible for delimiting the Event of a given verb and hence is renamed here EventP, whose head makes the semantic contribution of causation (CAUSE) to the eventual incorporated verbal form. Verbs without a “causer” argument, and hence without a specifier of EventP, are headed by an Event head whose semantic contribution to the verb with which it incorporates is represented as BE, or possibly, HAPPEN. Incorporated forms delimited by the EventP have the status of “word-level” items, while iterations of EventP produce “biclausal” syntax, with two events. It is this notion which crucially allows the resurrection of the generative semantics argument for verbal decomposition into “primitive” semantic units. In support of such decomposition, we consider the possible breakdown of double object verbs like “give” into a semantic primitives “CAUSE to HAVE”. Certain languages observably do not have a possessive “HAVE” primitive; such languages should also lack the double object construction, if this construction is composed of primitives in the manner suggested above. The prediction is examined with respect to several languages from distinct language families, and at least preliminarily appears well-founded.

In the second half of the thesis, we move on to questions of case-assignment and licensing of nominal projections, a topic we essentially ignored throughout most of the

preceding discussion. Many of the constructions (notably the possessive) examined in previous chapters evince a peculiar case-marking pattern, where the subject is marked with dative case and the object with nominative. These constructions constitute another instance of a “subject” property mismatch, whereby nominative case, usually indicative of subjecthood, appears on an object argument. Tests of these constructions in Icelandic indicate clearly that in every respect these nominative objects behave exactly like accusative objects in standard transitive constructions. With this fact in mind, a mechanism for assigning morphological case is proposed which modifies standard assumptions about the strict connection of morphological case with structural position, crucially appealing to the notion of a “mandatory” and “dependent” case. On this account, nominative is the case which must be assigned if no other structural case is assigned in a clause. A similar conclusion is drawn with respect to dative case in Japanese analytic (not lexical) causative constructions; an extended treatment of these constructions is undertaken.

Finally, given the revised version of the case-assignment mechanism, the question of NP-licensing is re-examined, with an eye to dispensing with abstract case entirely; the apparent effects of abstract case assignment (and, incidentally, Buzio’s Generalization) are seen to be the result of the coincidental interaction of the mechanism governing morphological case assignment with the Extended Projection Principle. The EPP, as conceived here, requires that a slot in clause structure be occupied overtly; in Minimalist terms, a strong feature in some high-up projection (here TP1) requires checking. We then move on to speculation about the provenance of dative-nominative constructions cross-linguistically, and conclude with some remarks about the interaction of the analysis of auxiliary verbs and verbal participles with the proposed system of case-checking and subject licensing.

The conclusions contained herein have wide-ranging implications for both the theory of the lexicon and of NP-licensing. Much of the present research is to be considered work in progress, and it is to be hoped that future results will support the sometimes

preliminary analyses presented here. Any thoughts or comments from readers of this work are more than welcome: send to [hharley@mit.edu](mailto:hharley@mit.edu), or [charley@play.psych.mun.ca](mailto:charley@play.psych.mun.ca). Thanks for reading this far!



## *Bibliography*

---

- Andrews, Avery D. (1990) "The VP-complement analysis in Modern Icelandic," in Joan Maling and Annie Zaenen (eds.) *Modern Icelandic Syntax, Syntax and Semantics* 24:165-85, SanDiego:Academic Press
- Baker, M. (1988) *Incorporation: A Theory of Grammatical Function Changing*, University of Chicago Press: Chicago
- Baker, M., K. Johnson and I. Roberts (1989) "Passive Arguments Raised," *Linguistic Inquiry* 20: 219-251.
- Baltin, M. (1995), "Floating Quantifiers, PRO and Predication", *Linguistic Inquiry* 26:199-248
- Barss, A. and H. Lasnik (1986) "A Note on Anaphora and Double Objects," *Linguistic Inquiry*, 17:347-354
- Bobaljik, Jonathan David (1993) "Ergativity and Ergative Unergatives," in *Papers on Case and Agreement II*, MITWPL Vol. 19, Cambridge:MITWPL
- Bobaljik, J (1994) "What Does Adjacency Do?," in Heidi Harley and Colin Phillips, eds, *Proceedings of the Morphology-Syntax Connection*, MITWPL 22 1-32, Cambridge, Massachusetts

- Bobaljik, J (1995) *Morphosyntax: The Syntax of Verbal Inflection*, Doctoral dissertation, MIT: Cambridge, Massachusetts
- Bobaljik J. and Carnie A. (1992). 'A Minimalist Approach to Some Problems of Irish Word Order' *Proceedings of the Harvard Celtic Colloquium XII* 110-134, (revised version to appear in *Celtic and Beyond*, I. Roberts and R. Borsley eds. Cambridge University Press)
- Bobaljik, Jonathan David & Dianne Jonas (forthcoming) "Subject Positions and the Roles of TP," *Linguistic Inquiry*.
- Bowers, J (1993) "The Syntax of Predication," *Linguistic Inquiry* 24, 4:591-656
- Bresnan, J. (1977) "Variables in the Theory of Transformations", in Peter W. Culicover, Thomas Wasow, and Adrian Akmajian, eds., *Papers from the MSSB-UC Irvine Conference on the Formal Syntax of Natural Language*, 157-96, Academic Press, New York
- Bresnan, J. (1982) "The Passive in Lexical Theory," in J. Bresnan, ed. *The Mental Representation of Grammatical Relations*, 3-86, MIT Press, Cambridge, Massachusetts.
- Bresnan, J. (1993) "Locative Inversion and the Architecture of Universal Grammar," *Language*, 70:1, 72-131
- Bures, Anton (1992) "Re-Cycling Expletive (and other) Sentences," ms. MIT
- Burzio, Luigi (1986) *Italian Syntax*, Dordrecht: Reidel
- Burzio, Luigi (1994) "Case Uniformity," ms., Johns Hopkins University
- Carnie, Andrew (1995). *Non-verbal predication and head movement*, Doctoral dissertation, MIT: Cambridge, Massachusetts
- Carnie, Andrew and Heidi Harley (forthcoming) "Nominally Phrasal Copular Constructions," To appear in *Proceedings of WECOL (94)* University of California, Los Angeles
- Cena, Resty (1994) *Tagalog Syntax: A First Course*, SWAMI (Supporters of Writers, Artists, and Musicians, International)
- Choe, Hyon Sook (1987) "An SVO analysis of VSO Languages and Parameterization : A study of Berber" in Guerssel and K. Hale (1987) *Studies in Berber Syntax*. Lexicon Project Working Paper, Center for Cognitive Science, MIT, Cambridge Mass (MITWPL)
- Chomsky, N. (1970) "Remarks on Nominalization," in R. Jacobs and P. Rosenbaum, eds. *Readings in English Transformational Grammar*:184-221, Georgetown University Press, Washington
- Chomsky, N. (1981), *Lectures on Government and Binding*, Dordrecht: Foris
- Chomsky, N (1986), *Knowledge of Language: Its Nature, Origin and Use*, New York: Praeger



- Chomsky, N. (1991) "Some Notes on Economy of Derivation and Representation," in Robert Freidin, ed., *Principles and Parameters in Comparative Grammar*, pp. 417-454, Cambridge: MIT Press
- Chomsky, Noam & Howard Lasnik (1993) "Principles and Parameters Theory", In J. Jacobs, A. von Stechow, W. Sternfeld and T. Vennemann (eds.), *Syntax: An International Handbook of Contemporary Research*, Berlin: Walter de Gruyter.
- Chomsky, N. (1994) "A Minimalist Program for Linguistic Theory," in K. Hale & S. J. Keyser, eds., *The View From Building 20*:1-52, Cambridge:MIT Press
- Chung, Sandra and James McCloskey (1987) "Government, Barriers, and Small Clauses in Modern Irish," *Linguistic Inquiry* 18.2: 173-238.
- Collins, Chris and Höskuldur Thráinsson (1993) "Object Shift in Double Object Constructions and the Theory of Case," in Colin Phillips, ed., *Papers on Case and Agreement II*, MITWPL Vol. 19 131-174, Cambridge, Massachusetts
- Comrie, B. (1981) *Language Universals and Linguistic Typology*, Oxford: Basil Blackwell
- Contreras, H. (1987), "Small clauses in Spanish and English," *Natural Language and Linguistic Theory* 5, 225-244
- Déchaine, Rose-Marie (1993) *Predicates Across Categories*, Doctoral dissertation, University of Massachusetts, Amherst, Massachusetts
- Deising, M. (1994) XXobject shift paper presented at Germanic Syntax workshop at Harvard in January.
- Déprez and Hale (1986) "Resumptive Pronouns in Irish" Proceedings of the Harvard Celtic Colloquium V, 38-48.
- Duffield, Nigel (1991) *Particles and Projections*. Ph.D. Dissertation University of Southern California
- Duffield, Nigel (1994) "Are You Right?" Paper presented at the Generative Parasession at the Conference on Language in Ireland, Jordanstown Northern Ireland.
- Emonds, (1977) "Comments on the Paper by Lightfoot" in Peter W. Culicover, Thomas Wasow, and Adrian Akmajian, eds., *Papers from the MSSB-UC Irvine Conference on the Formal Syntax of Natural Language*: 239-47, Academic Press, New York
- Emonds, J (1980) "Word Order in Generative Grammar" *Journal of Linguistic Research* 1, 33-54.
- Fillmore, C.J. (1968) "The Case for Case " in Bach, Emonn and R.T. Harms, eds, *Universals in Linguistic Theory*, New York: Holt, Rinehart and Winston, 1-88
- Fodor, J. A. (1970) "Three reasons for not deriving 'kill' from 'cause to die'," *Linguistic Inquiry* 1:429-438
- Freeze, R. (1992), "Existentials and other locatives," *Language* 68, 3:553-596

- Fukui and Speas (1986) in Fukui, N., T. Rapoport and E. Sagey, eds., *Papers in Theoretical Linguistics*, MITWPL 8 128-172, Cambridge, Massachusetts
- Grimshaw, J. (1990), *Argument Structure*, MIT Press, Cambridge, Massachusetts
- Grimshaw, Jane and Strang Burton (1992) "Coordination and VP-Internal Subjects," *Linguistic Inquiry* 23, 305-313
- Guéron, J. (1986) "Le verbe 'avoir'," *Recherches Linguistiques* 14
- Guilfoyle, E., H. Hung and L. Travis (1992) "Spec of IP and Spec of VP: Two Subject Positions in Austronesian Languages," in *Natural Language and Linguistic Theory* 10: 375-414.
- de Hackbeil, Hanna W (1989)  *$\theta$ -Government, Thematic Government and Extraction Asymmetries in Zero Derivation*. Centrum voor Wiskunde en Informatica: Amsterdam
- Haegeman, L. (1991) *Introduction to Government and Binding Theory*, Blackwell: Oxford
- Hale, K. (1973) "A note on subject-object inversion in Navajo," in Y. Kachru et. al, eds. *Issues in Linguistics: Papers in Honor of Henry and Renée Kahane*, 300-309: University of Illinois Press: Urbana, Illinois.
- Hale, K (1989) "Incorporation and Synthetic Verb forms in Irish" ms. MIT, Cambridge MA
- Hale, K. (1995) "Have and Be: Linguistic Diversity in the Expression of Simple Relations," presidential address, 1995 LSA annual meeting
- Hale, K. and J. Keyser (1991). "On the syntax of argument structure" Lexicon Project Working Paper #34, MIT Center for Cognitive Science.
- Hale, K. and J. Keyser (1994) "On argument structure and the lexical expression of syntactic relations," in Hale and Keyser (1994), eds. *The View from Building 20*: 53-109, MIT Press: Cambridge, Massachusetts
- Hale, K. and J. Keyser (1994) *The View from Building 20*, MIT Press: Cambridge, Massachusetts
- Halle, M. and A. Marantz (1994) "Distributed Morphology," in Hale and Keyser (1994), eds. *The View from Building 20*: 111-76, MIT Press: Cambridge, Massachusetts
- Harley, H. (1991) "A Review of 'Passive Arguments Raised'," ms, MIT
- Harley, H. (1994), "The Case of the Icelandic Experiencer," ms, MIT
- Harley, H. (1995), "Abstracting Away from Abstract Case," in J. Beckman, ed., *Proceedings of NELS 25*, GLSA: Amherst

- Harley, H. (forthcoming) "The Minimalist Japanese Causative," in H. Ura, R. Pensalfini and M. Koizumi, eds, *MITWPL 26*, MITWPL:Cambridge
- Harris, A. (1981) *Georgian Syntax: A Study in Relational Grammar*, Cambridge University Press: Cambridge
- Holloway-King, T. (1993) "Spec AgrP and Case: Evidence from Georgian," in H. Harley and Colin Phillips, eds, *The Morphology-Syntax Connection*, MITWPL 22 91-110: Cambridge, Massachusetts
- Holloway-King, T. (1993) "VP-Internal Subjects in Russian," paper presented at the 2nd Workshop on Formal Approaches to Slavic Linguistics, MIT.
- Huang, J. (1992). "Reconstruction and the Structure of VP: Some Theoretical Consequences," *Linguistic Inquiry* 24: 103-138.
- Jacobsen, W.M. (1992) *The Transitive Structure of Events in Japanese*, Kurosiso Publishers.
- Johnson, K. (1991) "Object Positions," *Natural Language and Linguistic Theory* 9, 577-636
- Jonas, D. (1992) "Checking Theory and Nominative Case in Icelandic," in S. Kuno and H. Thráinsson, eds. *Harvard Working Papers in Linguistics 1*, 175-196.
- Jonas, D. (1993), "The TP Parameter in Scandinavian Syntax," to appear in C. Hedlund and A. Holmberg (eds.) *Gothenburg Working Papers in Linguistics: Papers from the Scandinavian Syntax Workshop*
- Jonas, D. and Bobaljik, J. (1993) "Specs for subjects: the role of TP in Icelandic," in Jonathan D. Bobaljik and Colin Phillips, eds, *Papers on Case and Agreement I*, MITWPL Vol. 18 59-98, Cambridge: MITWPL
- Kayne, R.S. (1993) "Toward a modular theory of auxiliary selection," *Studia Linguistica* 47, 3-31.
- Kayne, R.S. (1994) *The Antisymmetry of Syntax*, MIT Press, Cambridge Mass.
- Keyser, S.J. and T. Roeper (1984) "On the Middle and Ergative Constructions in English," *Linguistic Inquiry* 15, 381-416.
- Kitagawa, Y. (1986) *Subjects in Japanese and English*, Doctoral dissertation, University of Massachusetts, Amherst
- Koizumi, M (1993) "Object Agreement and the Split VP Hypothesis," in Jonathan D. Bobaljik and Colin Phillips, eds, *Papers on Case and Agreement I*, MITWPL Vol. 18 99-148, Cambridge: MITWPL
- Koizumi, M. (1994) "Nominative objects: the role of TP in Japanese," in M. Koizumi and H. Ura (eds.) *Proceedings of Formal Approaches to Japanese Linguistics I*, MITWPL Vol. 24, Cambridge: MITWPL
- Koizumi, M. (1995) *Phrase Structure in Minimalist Syntax*, Doctoral dissertation, MIT.

- Kondrashova, N. (1993) XX, ms. Cornell
- Koopman, H. and D. Sportiche, (1985) "Theta-Theory and Extraction", *GLOW Newsletter* 14, 57-58
- Koopman, Hilda and Dominique Sportiche (1991) "The Position of Subjects" *Lingua* 85, 211-258.
- Kratzer, A. (1993) "On External Arguments," *University of Massachusetts (Amherst) Occasional Papers* 17, 103-130.
- Kubo, M. (1990) "Japanese Passives", ms. MIT
- Kuroda, Y. (1965) *Generative Grammatical Studies in the Japanese Language*, Doctoral dissertation, MIT
- Kuroda, Y. (1988) "Whether We Agree or Not," *Linguisticae Investigationes* 12, 1-47.
- Kuroda, Y (1994) "Lexical and Productive Causatives in Japanese: an examination of the theory of paradigmatic structure," in *Journal of Japanese Linguistics*
- Larson, R. (1988), "On the Double Object Construction," *Linguistic Inquiry* 19, 335-392
- Lasnik, H. and M. Saito (1991), "On the Subject of Infinitives," *CLS* 21
- Levin, B. (1993) *English Verb Classes and Alternations: A Preliminary Investigation*, University of Chicago Press: Chicago
- Li, Charles N. (1976) (ed.) *Subject and Topic*, Academic Press: New York
- Mahajan, Anoop (1994), "The ergativity parameter: *have-be* alternation, word order and split ergativity," in Mercè González, ed., *Proceedings of NELS 24* 317-331
- Marantz, A. (1984) *On the Nature of Grammatical Relations*, MIT Press, Cambridge, Massachusetts.
- Marantz, Alec (1991) "Case and Licensing," in Germán F. Westphal, Benjamin Ao and He-Rahk Chae (Eds.), *ESCOL '91: Proceedings of the Eighth Eastern States Conference on Linguistics*, 234-253.
- Marantz, A. (1993) "Implications of Assymetries in Double Object Constructions," in S. A. Mchombo, ed *Theoretical Aspects of Bantu Grammar*, Leland Stanford Junior University.
- Marantz, D. (1985) "Case Theory and the Projection Principle," PhD Dissertation, MIT, Cambridge:MITWPL
- May, R. (1985) *Logical Form*, MIT Press, Cambridge, Massachusetts
- McCone, K. 1987. *The Early Irish Verb An Sagart*: Maynooth
- McCloskey, James (1992b) 'On the scope of verb movement in Modern Irish'. Technical Report LRC-92-10. Linguistics Research Center, Cowell College University of California at Santa Cruz.

- McNally, Louise (1992) "VP Coordination and the VP-Internal Subject Hypothesis," *Linguistic Inquiry* 23: 336-341
- Miyagawa, S. (1980) *Complex Verbs and the Lexicon*, Doctoral dissertation, University of Arizona
- Miyagawa, S. (1984) "Blocking and the Japanese Causative," *Lingua* 64 177-207
- Miyagawa, S. (1986) "Restructuring in Japanese," in T. Imai and M. Saito, eds., *Issues in Japanese Linguistics* 273-300, Foris: Dordrecht
- Miyagawa, S. (1989) *Structure and Case Marking in Japanese*, Academic Press
- Miyagawa, S. (1988) "Predication and Numeral Quantifier," in William J. Poser, ed. *Papers from the Second International Workshop on Japanese Syntax* 157-192, Stanford: Center for the Study of Language & Information
- Miyagawa, S. (1994) "Sase as an Elsewhere Causative," in the program of *Linguistic Theory and Japanese Language Teaching*, Seventh Symposium on Japanese Language, Tsuda Japanese Language Center
- Miyagawa, S. (1995, forthcoming), "Against Optional Scrambling," to appear in *Linguistic Inquiry*, MIT Press: Cambridge, MA
- Murasugi, Kumiko (1994) "A constraint on the Feature Specification of AGR", in H. Harley and C. Phillips, eds. *The Morphology-Syntax Connection*, MITWPL 22 131-152, Cambridge, Massachusetts
- Nash, L. (1994) "On BE and HAVE in Georgian," in H. Harley and C. Phillips, eds. *The Morphology-Syntax Connection*, MITWPL 22 153-171, Cambridge, Massachusetts
- Noonan, Máire (1993) "Statives, Perfectives and Accusativity: The importance of being Have," in J. Mead, ed., *Proceedings of the West Coast Conference on Formal Linguistics* 11, 354-370.
- Oehrle, R. (1976) *The Grammatical Status of the English Dative Alternation*, PhD dissertation, MIT
- Oehrle, R and Nishio, H. (1981) "Adversity," *Coyote Papers* 2, University of Arizona Linguistic Circle: Tuscon Arizona
- Pesetsky, D. (1989) "Language-Particular Processes and the Earliness Principle," ms., MIT
- Pesetsky, D. (1994a) *Zero Syntax*, Vol II (Chpts 8-12), ms., MIT
- Pesetsky, D. (1994b) *Zero Syntax*, MIT Press: Cambridge
- Pintzuk (1991). *Phrase structures in competition: variation and change in Old English word order*. PhD Dissertation, University of Pennsylvania.

- Pollock, Jean-Yves (1989) Verb-movement, Universal Grammar and the Structure of IP," *Linguistic Inquiry*, 20, 365-454
- Postal, P. (1974), *On Raising*, MIT Press: Cambridge, Massachusetts
- Rice, K. (1991) "Predicting the order of disjunct morphemes in the Athapaskan languages," Toronto University Working Papers in Linguistics 11, 99-121
- Rice, K. and L. Saxon (1994) "Subject Positions in Athapaskan Languages," in H. Harley and C. Phillips, eds. *The Morphology Syntax Connection*, MITWPL Vol. 22 173-195, Cambridge, Massachusetts
- Richards, N (1995) "Another Look at Tagalog Subjects" ms., MIT
- Ritter, E. (1994) "On the syntactic category of pronouns and agreement," *Natural Language and Linguistic Theory*
- Ritter, E. and S.T. Rosen (1993) "Deriving Causation," *Natural Language and Linguistic Theory* 11: 519-555
- Rizzi, L. (1990) *Relativized Minimality*, MIT Press: Cambridge, Massachusetts
- Rögnvaldsson, Erikur (1990) "Null Objects in Icelandic," in Maling and Zaenen, eds, *Syntax and Semantics*, Vol. 24 367-79, New York:Academic Press
- Rosen, C. and K. Wali (1989) "Twin Passives, Inversion and Multistratality in Marathi," *NLLT* 7: 1-50
- Rosen, S. T. (1989) *Argument Structure and Complex Predicates*, Doctoral dissertation, Brandeis University, Waltham, Massachusetts. (Reprinted as *Argument Structure and Complex Predicates*, Garland, New York, 1990).
- Ross, H. (1967) *Constraints on Variables in Syntax*. Doctoral dissertation, MIT, Cambridge, Massachusetts.
- Rothstein, S. (1983) *The Syntactic Forms of Predication*, Doctoral dissertation, MIT, Cambridge, Massachusetts.
- Sadakane, K. and M. Koizumi (1995) "On the nature of the 'dative' particle *ni* in Japanese," *Linguistics* 33:5-33
- Saxon, L. and K. Rice (1993) "On Subject Verb Constituency: Evidence from Athapaskan Languages," In *Proceedings of the West Coast Conference in Formal Linguistics*: 11: 434-450
- Schütze, Carson (1993) "Feature Checking and Quirky Case in Icelandic", Ms., MIT.
- Schütze, Carson (1994) "Serbo-Croatian Second Position Clitic Placement and the Phonology-Syntax Interface," in A. Carnie and H. Harley, eds, *Papers in Phonology and Morphology*, MITWPL 21 373-465, Cambridge, MA
- Sigurðsson, Halldór A'rmann (1989) *Verbal Syntax and Case in Icelandic*, PhD dissertation, Lund.

- Sigurðsson, Halldór A'rman (1991) "Icelandic Case-Marked PRO and the Licensing of Lexical Arguments," *Natural Language and Linguistic Theory*, Vol. 9, No. 2, 327-364
- Speas, M. (1986) *Adjunctions and Projections in Syntax*, Doctoral dissertation, MIT, Cambridge, Massachusetts
- Speas, M. (1991) "Functional Heads and the Mirror Principle," *Lingua* 84: 181-214
- Sportiche, D (1988) "A Theory of Floating Quantifiers and Its Corollaries for Constituent Structure," *Linguistic Inquiry* 19, 425-449.
- Sridhar, S. N. (1976) "Dative subjects, rule government and relational grammar," *Studies in the Linguistic Sciences*, Vol. 6, No. 1, Spring 1976.
- Stillings, J. (1975). "Gapping in English and Variable Types," *Linguistic Analysis* 1, 247-274
- Stowell, Tim (1981) *Origins of Phrase Structure*, PhD. Dissertation, MIT, Cambridge, Massachusetts
- Stowell, Tim (1989) "Raising in Irish and the Projection Principle". *Natural Language and Linguistic Theory* 7: 317-359
- Stowell, Tim (1991) "Notes on Restructuring," in Robert Frieden, ed, *Principles and Parameters in Comparative Grammar*, MIT Press, Cambridge, 182-218
- Strachan, J. (1984) *Old Irish paradigms and glosses* 4th edition. Royal Irish Academy: Dublin
- Takano, Yuji (1995) "Predicate Fronting and Internal Subjects," *Linguistic Inquiry* 26, 2:327-340
- Takezawa, Koichi (1987), Kondrashova, NataA *Configurational Approach to Case-Marking in Japanese*, PhD. dissertaion, University of Washington.
- Tenny, C. (1987) *Grammaticalizing Aspect and Affectedness*, Doctoral dissertation, MIT: Cambridge, Massachusetts.
- Tenny, C. (1994) *Aspectual Roles and the Syntax-Semantics Interface*, Kluwer: Dordrecht
- Terada, M. (1991) *Incorporation and Argument Structure in Japanese*, PhD dissertation, University of Massachusetts, Amherst, Amherst:GLSA
- Thurneysen, R (1980) *A Grammar of Old Irish: An Enlarged edition with supplement* (first ed 1941). Translated by Binchy and Bergin. Dublin Institute for Advanced studies. Dublin.
- Travis, L. (1984) *Parameters and Effects of Word Order Variation*, Doctoral dissertation, MIT.

- Travis, L. (1988) "The Syntax of Adverbs," in *Proceedings of the IVth Comparative Germanic Syntax Workshop*, McGill Working Papers in Linguistics: Montreal, Canada
- Travis, L. (1991), "Inner Aspect and the Structure of VP," in *Proceedings of NELS XXII*, University of Delaware, GLSA: Amherst
- Travis, L. (1994), "Event Phrase and a theory of functional categories," paper presented at the Canadian Linguistics Association meeting, 1994, University of Calgary. (in *Proceedings...*)
- Ura, Hiroyuki (forthcoming), *Multiple feature-checking: a theory of grammatical function splitting*, Doctoral dissertation, MIT
- Uribe-Etxebarria, Maria (1994): *Interface Licensing Conditions on Negative Polarity Items: a Theory of Polarity and Tense Interactions*. PhD Dissertation, University of Connecticut, 1994.
- Vergnaud, J-R (1985) *Dépendences et niveaux de représentations en syntaxe*, John Benjamins: Amsterdam
- Verma, Manindra K, and K.P. Mohanan, eds: (1990) *Experiencer Subjects in South Asian Languages*, Stanford: CSLI.
- Watanabe, A. (1993) *Agr-Based Case Theory and its Interaction with the A-Bar System*, MIT dissertation, Cambridge: MITWPL
- Watanabe, A. (1994) "Locative Inversion: Where Unaccusativity Meets Minimality," ms., University of Tokyo
- Williams, E. S. (1983) "Against Small Clauses," *Linguistic Inquiry* 14.2, 287-308
- Williams, E.S. (1994) *Thematic Structure in Syntax*, MIT Press: Cambridge, Massachusetts
- Woolford, E. (1991) "VP-Internal Subjects in VSO and Nonconfigurational Languages," *Linguistic Inquiry*, 22, 503-540
- Yip, Moira, Joan Maling and Ray Jackendoff (1987) "Case In Tiers," *Language* 63.2, 217-250.
- Zaenen, A, J. Maling and H. Thráinsson (1985) "Case and grammatical functions: the Icelandic passive," *Natural Language and Linguistic Theory*, Volume 3 pp. 441-483.
- Zagona, K. (1982) *Government and Proper Government of Verbal Projections*, Doctoral dissertation, University of Washington, Seattle.
- Zubizarreta, M.L. (1982) *On the Relationship of the Lexicon and Syntax*, Doctoral dissertation, MIT, Cambridge, Massachusetts.