

Ergonomic, Adaptable Keyboard for
Fast Data Entry on Mobile Computing Devices

by

Alexander Mekelburg

Submitted to the Department of Mechanical Engineering in
Partial Fulfillment to the Requirements for the Degree of

Bachelor of Science

at the

Massachusetts Institute of Technology

May 2005 [June 2005]

© 2005 Massachusetts Institute of Technology
All Rights Reserved

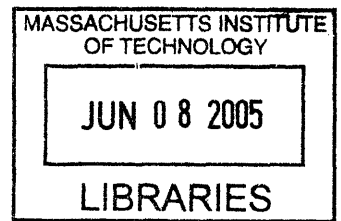

Signature of Author.....
Department of Mechanical Engineering
May 16, 2005

Certified by.....
Stephen S. Intille
Research Scientist
Thesis Supervisor

Accepted by.....
Ernest G. Cravalho
Chairman, Undergraduate Thesis Committee

ARCHIVES

Ergonomic, Adaptable Keyboard for
Fast Data Entry on Mobile Computing Devices

by

Alexander Mekelburg

Submitted to the Department of Mechanical Engineering on May 16, 2005 in
Partial Fulfillment to the Requirements for the Degree of Bachelor of Science

ABSTRACT

The usefulness of modern portable computational devices such as cellular phones and portable digital assistants (PDAs) is currently limited by the lack of an effective method for text entry. The currently available input options (such as the 12-key phone pad and PDA touch screens) are a quarter to a third of the speed of the standard desktop QWERTY keyboards. Therefore, it is slow and frustrating for people to use these systems for any significant text input, such as writing emails, taking notes in a meeting, or writing down thoughts while on-the-go.

The proposed solution is a one-handed, hand-held, wireless, portable keyboard that would allow the mobile device user to achieve speeds closer to the desktop standard while performing text-entry tasks. Previously developed handheld input devices employ unfamiliar typing systems, are too large, or are not ergonomically comfortable, which may be the reasons they have not been widely adopted by the public. The device described in this paper is small enough to store in one's pocket, is inconspicuous during use, and is adjustable so that the keys reach the fingers in their natural curved position. One interface point allows each finger to control multiple buttons thereby preventing the fingers from needing to move into uncomfortable positions.

These features were incorporated into a prototype that proves the feasibility of a compact and comfortable hand-held keyboard. The device also has potential as an ergonomic replacement to the standard desktop keyboard. Unlike traditional keyboards it allows the typist to be relaxed and mobile eliminating some risk factors for repetitive strain injury.

Thesis Supervisor: Stephen S. Intille

Title: Research Scientist

1. Introduction

As of December 2004 global cell-phone use exceeded 1.5 billion people [16] with over 180 million in the U.S. [3]. Additionally the use of personal digital assistants (PDAs) has continued to increase [25], and the PDA industry is now over \$1 billion per year [34]. However, research has shown that only one third to one half of the PDA owners carry their devices around [34]. The amount of text messaging (135 billion SMS messages sent globally in the first quarter of 2004 [16]) shows that people are welcoming the use of portable devices for text-based communications, but the input methods are not convenient enough to do text-intensive tasks like writing emails. The average speeds of current popular mobile text entry methods range from 5-25 words per minute (WPM) [10, 29, 15, 11, 33, 2], which is slow compared to the average desktop QWERTY speeds of 50-70 WPM [10, 11, 2]. If people had a comfortable, fast and accurate way to interact with their portable computational devices, they would be able to use mobile devices more productively by accomplishing tasks that require text entry. For example, notes can quickly be taken on a productive, impromptu conversation with a co-worker during a walk to lunch. Or a forgotten but important and timely email can be sent during the morning bus ride.

Although the QWERTY keyboard is the current PC input standard, there are ergonomic problems associated with stationary desktop keyboards. They force the users to sit at their computers with their backs, arms and wrists stationary (and often tense) for long periods of time while they type. Typing guidelines therefore encourage computer users to take breaks to get up and move around. A better solution is a keyboard that doesn't keep their body rigid – one that lets the user be relaxed and mobile while typing [18, 13].

In this paper a hand-held, portable, wireless keyboard is introduced that may improve both mobile text entry and traditional desktop keyboard data entry. The prototype device is the first to be compact enough for comfortable storage and discreet use while also placing the fingers in a comfortable, natural position. It provides the ability to utilize existing typing skills by being able to mimic the layout of QWERTY keyboard. The device can be used in one hand for quick on-the-go text entry, or two could be used simultaneously for faster typing [11]. These particular features address issues that may be the key obstacles to the adoption of existing hand-held keyboards.

2. Prior Work

An extensive review of currently available methods for mobile text-entry can be read in [21] and [33]. Presented here are the more commonly used systems and some prototypes for hand held devices

2.1 Current Typing Systems

The most popular method for data entry on mobile phones is the standard 12 key phone pad using either a multi-tap or predictive (such as T9 [35]) typing system. The multi-tap system uses the standard letters assigned to each key on the phone pad (Figure 1a). When a key is pressed it initially displays the first letter on the key. Pressing repeatedly cycles through the letters on the key. The predictive system uses the same key labeling, but each key is only pressed once. It uses a dictionary to determine which letters the user intends to type and displays word possibilities. The system lets the user

cycle through the options or switch to multi-tap mode to enter non-dictionary terms. These phone pad systems are slow because they require multiple presses per letter and only allow users to type with one or two fingers or thumbs. The T9 in particular tends to confuse new users because the text on the screen doesn't always reflect what they think they are typing [33, 15].

Table 1: Ranges of Novice, Expert and Predicted typing speeds (in WPM) of various typing systems*

	Novice	Expert	Predicted
Standard QWERTY	24	50-100	150 (typist)
Mini-QWERTY	29-35	58-62	27.7
Multi-tap	2-8	5	21-27
T9	3-10	8-20	45-50
FASTAP	6-8	9	Not calculated
Graffiti/Unistroke	1-10	14	Not calculated

* This table shows ranges of typing speeds (for a variety of text styles from newspaper text to typical text message shorthand) from previous research [33, 11, 26, 32, 15, 29, 14, 10, 2] for novice and expert users. The expert data varies from 60 minutes to 25 hours of training. The column for "predicted" represents theoretical possibilities. For the standard QWERTY an average professional typist speed is given - the other predictions are calculations based on the work in [32].

Some systems that are not based on the phone pad include the mini-QWERTY and FASTAP. FASTAP adds buttons to the phone pad by inserting them in a 4x7 matrix superimposed upon the phone pad's 3x4 matrix (Figure 1b). This provides one key for each letter of the alphabet, but still limits the user to thumbs-only or 2-finger typing. The mini-QWERTY (Figure 1c) can be completely separate, or incorporated into devices such as the RIM blackberry and Nokia 6820 mobile phone [2]. Even though it provides the familiar QWERTY layout, it still limits the user to thumbs-only operation and requires the device to be held by both hands, which restricts mobility.

Another category of text entry is stylus-based input where the user makes marks or "strokes" on a touch-sensitive pad (Figure 1d). Stylus based systems include Palm graffiti [28] and Unistrokes [9]. Tests on these systems have shown that users do not surpass the writing speeds of traditional pen and paper hand-writing of 10-15 WPM [39, 9]

Another popular option for PDAs is a thin QWERTY keyboard that folds up for storage such as the palmOne Universal Wireless Keyboard [27] (Figure 1e). This is good for standard two-hand QWERTY typing when one doesn't have access to a computer (sitting on the plane or taking notes at a meeting), but it cannot be used for quick on-the-go entry while moving or standing. It takes time to set up and requires the user to be stationary and have a flat surface.

There has also been research into alternative typing systems such as half-QWERTY [22, 12, 23] and chording [11, 19, 20]. The half-QWERTY system lets users type the full QWERTY keyboard with just one hand by using the fact that the brain remembers finger motion and not spatial position. The keyboard maps the mirrored function of one hand to the other. For example, with the left hand one can type both an 'f' and a 'j' with their index finger by pressing down a mirroring shift key. Studies have shown that people with prior QWERTY experience can reach speeds of 34.7 WPM after 10 fifty-minute sessions [22]. A chording keyboard requires the user to press multiple

buttons at once to type each letter. This is similar to the idea of holding a mirror key in the half-QWERTY keyboard, but uses more key combinations, which allows for fewer buttons. Studies have shown that typing with one-handed chording keyboards can reach speeds of 30-60 WPM [11, 19, 20].

 <p>a. The Standard Phone Pad [4]</p>	 <p>b. FASTAP [6]</p>	 <p>c. mini-QWERTY [40]</p>
 <p>d. Touchpad/Stylus [5]</p>	 <p>e. palmOne wireless Keyboard [27]</p>	 <p>f. DataEgg [7]</p>
 <p>g. Chordite [24]</p>	 <p>h. CyKey [37]</p>	 <p>i. Twiddler [38]</p>

Figure 1: Mobile Text-Entry Systems

2.2 Current Hand-Held Devices

Several hand-held portable keyboards have been proposed in prior work. The Data Egg [7] and the Chordite [24] were developed to fit comfortably in one's hand. The data egg (Figure 1f) is compact and easy to store in a pocket (similar in size and shape to a cellular phone). However, it only has five keys and uses the Microwriter chording system developed by Cy Endfield and Chris Rainey, which maps the alphabet based on the shape characteristics of each letter [37, 7]. Despite the attempt at using the letter shape as a mnemonic, the system seems rather arbitrary, and the small number of keys makes it difficult to develop a different typing system that would take advantage of an individual's existing typing skills. Additionally, there is poor translation to other languages. The Chordite (Figure 1g) allows for a somewhat simpler system with a larger number of keys. Although it fits comfortably in the hand, it is not clear whether the device can be compact enough to store in a pocket. It is limited to two keys per finger and requires the user to press them with the middle of their finger as well as the tip. Neither of these systems has advanced beyond the conceptual prototype stage.

One chording keyboard that is commercially available is the CyKey [37], which also uses the Microwriter chording system (Figure 1h). It is compact and handheld but the shape requires the user to either have it on a flat surface or hold it with their fingers. The former prevents use while walking around and the later requires either two-handed use or an attempt at pressing the keys with the same fingers that are holding the device. A good-hand held keyboard needs to separate the functionality of pressing the keys from supporting the keyboard and keeping it in place [24].

The most studied and commonly found [24] hand-held keyboard is the HandyKey Twiddler [38] (Figure 1i). It provides full keyboard functionality as well as mouse control. It has three rows of four keys for the fingers and a set of buttons on the back for the thumb. It is strapped to the hand and fits comfortably, but is not easy to store due to its size. Also, the typing system is a chording system that does not allow for any translation of existing typing skills, and the key rows are set up in straight lines that often require the fingers to move into uncomfortable positions. There is also some initial physical discomfort associated with learning the device [38].

2.3 Other Alternative Keyboards

There is a group of alternative keyboards that differ significantly from the previously mentioned devices. These include "FingeRings" [8], which uses rings to detect the motion of the fingers relative to another point on the body, the SenseBoard [14], which wraps around each palm and uses sensors to detect the motion of the hand and fingers (Figure 2), and the Canesta Projection keyboard [1], which projects a full sized keyboard on a flat surface and detects finger motion on that surface (Figure 3). The main drawback to all of these systems is the lack of tactile feedback confirming when a button is pressed. Typing gloves that have been developed [17, 30, 10] may provide some physical feedback, but require the full-time wearing of gloves, which can be annoying and uncomfortable. Also, since the gloves generally use pressure sensitive pads, a good system to distinguish between use and non-use of the keyboard would need to be developed so that people could use their hands without having to remove their gloves. Also, some of the gloves require a significant amount of finger motion to enter the letters.

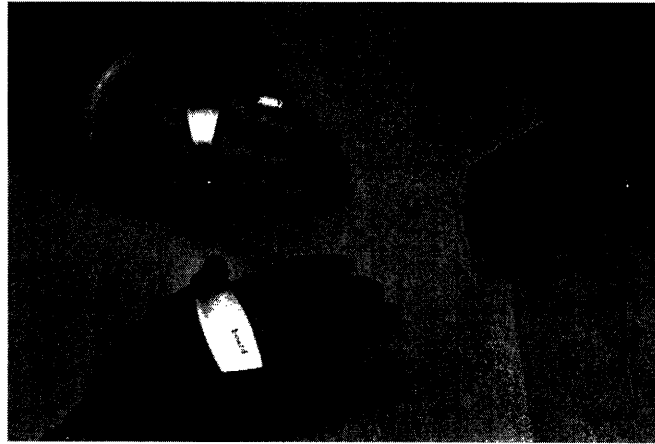

Figure 2: The Senseboard [31]



Figure 3: The Canesta Projection Keyboard [1]

3. Functional Requirements for a Hand-Held Keyboard

From the analysis of the previous prototypes as well as user interviews with clay models, functional requirements (FRs) for a hand-held portable keyboard were developed. These requirements were divided into four categories: use, storage, visual appeal, and general requirements.

3.1 Functional Requirements for Use

The most important Functional Requirements relate to the use of the keyboard, and, as there are many, they can be further broken down into 3 categories: The Typing Process, Comfort, and Flexibility.

Whatever mapping system is developed for the keyboard, the typing process must be unambiguous. For the physical design this means that there should not be any gesture-based input that can be unclear to detect and doesn't give the user any feedback. All commands given by the user should have tactile feedback. Whatever buttons are used on the keyboard should be easy and comfortable to press but be positioned to prevent keys from being accidentally pressed. Also, the keyboard should allow enough distinct input so that the user doesn't have to learn a large number of closely related chords or complex key sequences that may be confusing and frustrating to learn. It is also important that the

user can see what s/he is typing - this could be accomplished with the display on the computational device that the keyboard is interfacing with, but it would be better to have space for display (just enough for a line of text) on the keyboard itself. This would allow the user to accurately take quick notes on their keyboard without needing to access their PDA or cell phone.

To be a candidate for desktop keyboard replacement, the system needs to be comparable to the standard PC keyboard in terms of the ease and speed of typing. Therefore, the average user should be able to achieve typing speeds equivalent to the average typing speed on a standard QWERTY keyboard (50-100WPM). It's possible that this means one has to use two devices (one in each hand) to achieve this typing speed.

Comfort in using the device is essential. The shape should be such that it is comfortable to have in one's hand and provides easy and ergonomic access to all keys. It should allow a large range of natural movement while using it and not force the fingers into difficult positions. Above all it should not cause any pain to operate the device. It would also be good to be able to use the device without having to hold it with the same fingers you are typing with; it should naturally stay in place [24].

Another important aspect of the keyboard's use is its flexibility. It should be able to be used while doing other activities that don't require use of the typing hand such as walking down the street, riding the bus, talking with someone while standing, or even going for a run. It is also important that it's useable even when wearing thin gloves.

Table 2: Functional requirements for use

	Typing Systems				
	Standard QWERTY	Twiddler	Cell phone (multi-tap/T9)	Chordite	Proposed device
Typing Process					
Unambiguous	Y	Y	Y multi-tap only	?	Y
Tactile Feedback	Y	Y	Y	Y	Y
Visual Feedback	Y	Y	Y	Y	Y
Buttons Easy to Press	Y	Y	N	Y	Y
Keys aren't accidentally pressed	N	N	N	N	N
Can reach 50WPM	Y	Y	N	?	?
Can use with 1 or 2 hands for faster typing	Y	N	Y	?	Y
Comfort					
Useable without holding – stays in hand	N/A	Y	N	Y	Y
Doesn't cause pain	N	N	?	?	?
Comfortable to hold	N/A	Y	Y	Y	Y
Easy access to all keys	Y	N	Y	?	Y
Non confining to operate	N	N	Y	Y	Y
Promotes natural movement while in use	N	N	N	Y	Y
Flexibility					
Useable while doing other activities (non hand related)	N	Y	Y	Y	Y
Useable while wearing thin gloves	Y	Y	Y	Y	Y

3.2 Functional Requirements for Storage

The storage of the device is the next most important aspect. It should be quick to retrieve and stow away – ideally in one motion that takes no more time than answering one’s mobile phone. While stored it should be comfortable in one’s pocket, on one’s belt, or folded up in one’s hand, and it should stay in place and not get lost. It should also not prevent the user from performing a certain minimum set of actions with the typing hand (in the case of in-hand storage) such as picking up objects or opening doors. Lastly it should have a minimal number of parts so pieces don’t get lost. The device should be one continuous/connected piece with at most one other part that stays on a belt for storage purposes.

Table 3: Functional Requirements for Storage

	Typing Systems				
	Standard QWERTY	Twiddler	Cell phone (multi-tap/T9)	Chordite	Proposed device
Able to perform hand-related activities while stored	N/A	N	Y	?	Y
Stores comfortably	N/A	N	Y	?	Y
Stays put	N/A	Y	Y	Y	Y
Quick access/storage	N/A	N	Y	?	Y
One motion retrieval	N/A	Y	Y	Y	Y
Min. number of parts	N/A	Y	Y	?	Y

3.3 Functional Requirements for Visual Appearance

For the device to have any commercial success it must be visually appealing both while being used and while stored. People don’t want to have something that makes them look awkward or “nerdy.” This is hard to avoid with any new technology that is used in public, but there are ways to improve the transition to acceptance. One way is to use visual language similar to devices already in use (cell phones and PDAs in particular). Another way is to make the device be as discreet as possible. This means it is small enough to not easily be noticed when in use. It should also be appropriately sized for convenient storage. If it goes in the pocket, it should be thin so to not create a bulge or cause discomfort. Similarly anything on a belt should be designed to visually mesh with one’s clothes and body shape.

Table 4: Visual Functional Requirements

	Typing System				
	Standard QWERTY	Twiddler	Cell phone (multi-tap/T9)	Chordite	Proposed device
Discreet while used	N/A	N	Y	N	Y
Discreet while stored	N/A	N	Y	?	Y

3.4 General

There are other important Functional Requirements for a hand-held keyboard that are less influential on the choice of design family, but need to be taken into consideration when developing the final details for a marketable design. These are briefly presented in table 5.

Table 5: General Functional Requirements

	Typing System				
	Standard QWERTY	Twiddler	Cell phone (multi-tap/T9)	Chordite	My device
Usable in either hand	N/A	Y	Y	Y	Y
Can be used on it's own (no need for additional device)	N/A	N	Y	Y	?
Can be interfaced to any device	N/A	Y	N	?	Y
Robust/rugged enough to handle being thrown around	N/A	Y	Y	?	Y
Stands up to weather	N/A	?	Y	?	?

4. Design

In order to create a physical product that comprised all the functional requirements, the FRs were categorized based on how they influenced the form factor. Independent, specific solutions for each FR were developed and it was then determined how each solution would affect the form. These solutions were grouped according to physical compatibility and three final sets of compatible solutions were generated:

- A device that was small enough to permanently remain in the palm of one's hand (with a strap) that unfolded quickly when its use was desired
- A device with no moving parts that did not require a strap but could only be stored on the belt (too large for comfortable pocket storage)
- A device that would fold thin to fit in the pocket, but not necessarily require a strap for use.

It was decided that the first solution was best. It could stay in one's hand for a long period of time when alternating between use and non-use, and it provided the quickest access time. It would also be small enough to store well on one's belt, in a pocket, or in a purse for long periods of non-use.

The final design (as shown in Figure 4) consists of a base and a set of foldout keys. The base is shaped to fit comfortably in the palm while supporting the folding mechanism. It also holds and protects all the electronics. There are four finger keys that rotate out to reach the fingers when a thumb button is pushed. They lock in both the open and closed position, are angle-adjustable, and contain all the switches. The switches are configured so that each finger only has to interface with one part of the key (instead of having separate buttons for each switch). There is also a thumb key that contains three separate switches. This key also rotates out from a closed position, but it moves separately from the other keys. All of the switches connect to a MITes board [36] that sends data wirelessly to a receiver on a PC or cell phone.

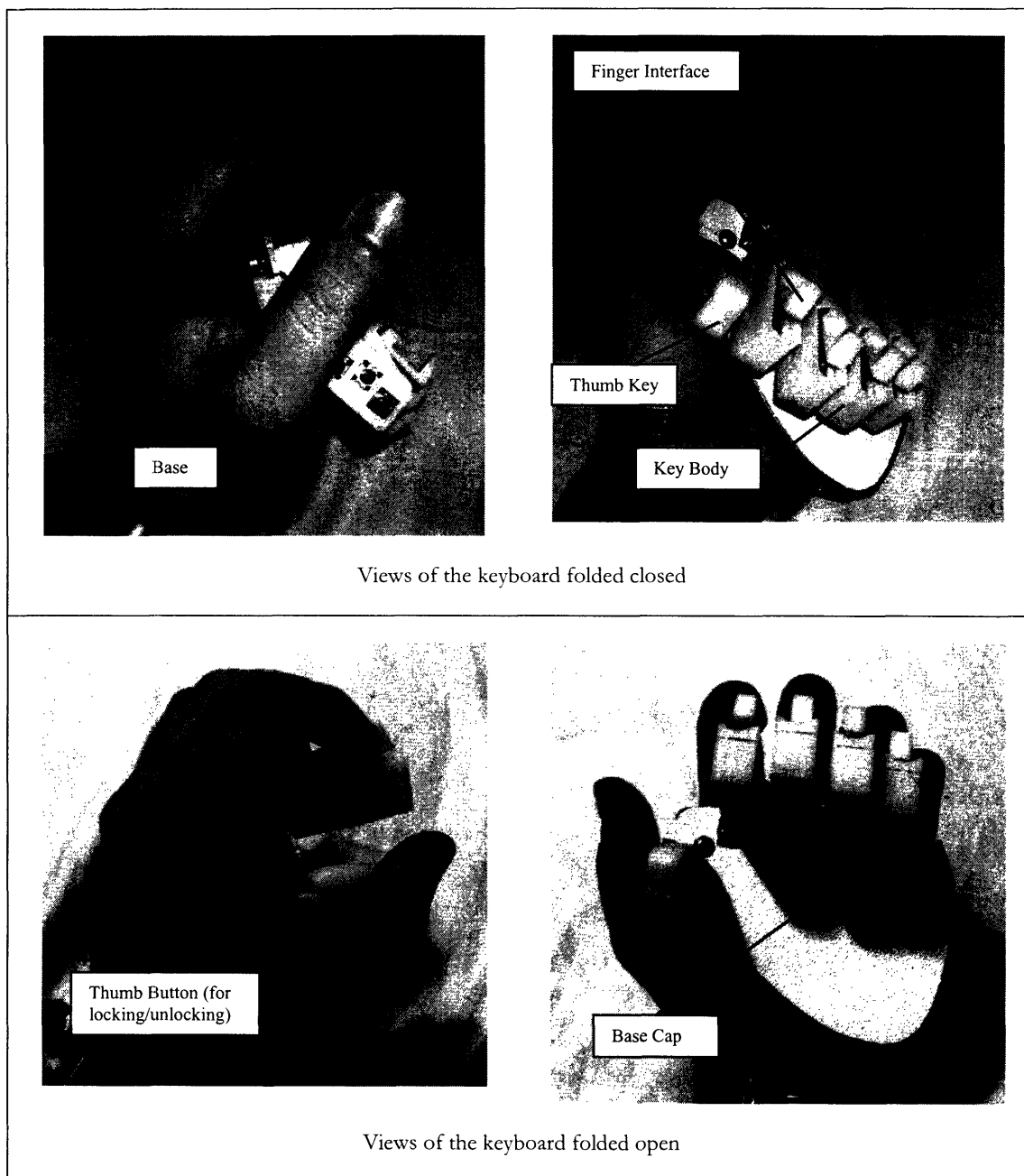

Figure 4: Four Views of the Proposed Keyboard Prototype

4.1 The form

To determine the ideal physical interface with one's hand, various clay models were developed and tested during the interviews. The results of these interviews showed that a small gourde-like shape (Figure 5) that fit the contours of the palm and let the fingers naturally curve around it was most comfortable. The particular clay model used

in the interviews was round and chunky, but it was possible to take the important characteristics of the form and incorporate them into the small folding design.



Figure 5: Gourde-shaped Clay Model

The two features taken from the gourde were the finger position and palm interface. The keys on the device fold out to reach the fingers in a natural curved position. The angle to which the keys fold out is individually adjustable for each user to customize the shape to his or her hand. Each key is also a different length allowing for the difference in the lengths of one's fingers.

The important aspects of the palm interface are that it provides a flat plane along the base of each finger and down the pinky side of the palm toward the wrist and allows space for the heel of the thumb. This gives a solid base to support the keyboard and also allows some mobility of the thumb. This is particularly important given that the keyboard is meant to stay strapped to the hand while not in use. Having thumb mobility allows for a wide range of functions (holding objects, opening doors, etc) so that wearing the keyboard doesn't overly interfere with everyday tasks. The flat plane across the palm also protects the center of the hand where there are many sensitive nerves.

4.2 The Keys and finger Interface

Each key is made of a key body that holds three buttons with wiring, a finger interface (that the finger uses to control the buttons), a top cap and a bottom cap. The main button is a microswitch manufactured by Zippy Shin Jiu Corporation (#SM-05 S-03A), which is held in the center of the key body by two pins. Behind this is an E-Switch #TL1105BF160Q Momentary Tact Switch, and in front is an E-Switch #TL1105SPF100Q Momentary Tact Switch (figure 6). The main button is activated directly by a press from the finger (the "click"), and the other two buttons are activated by sliding the main button backwards (towards the palm) or forwards (away from the palm) as shown in figure 7.

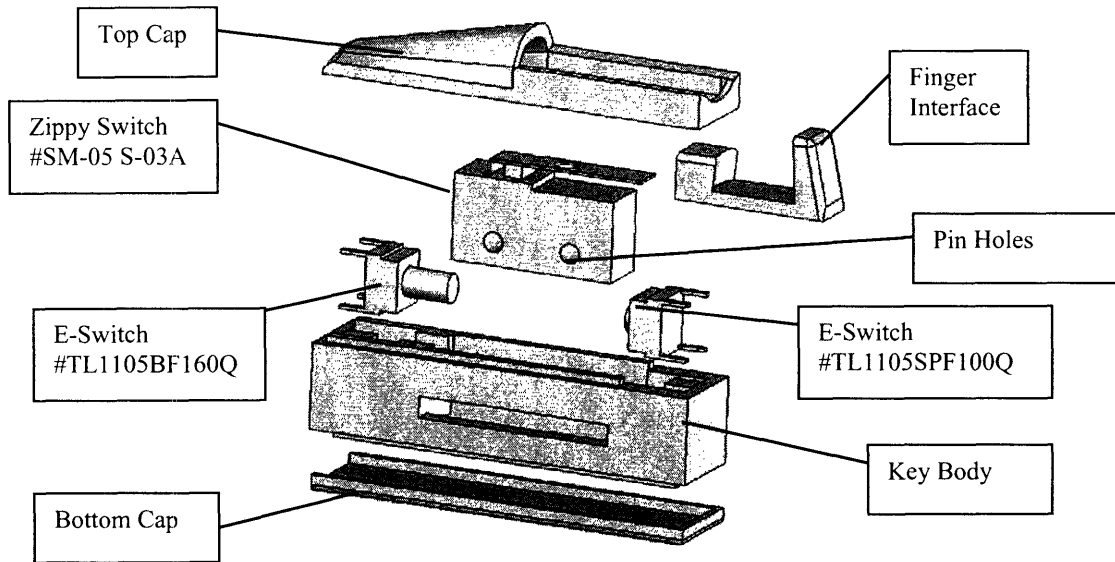

Figure 6: Exploded View of Key Assembly

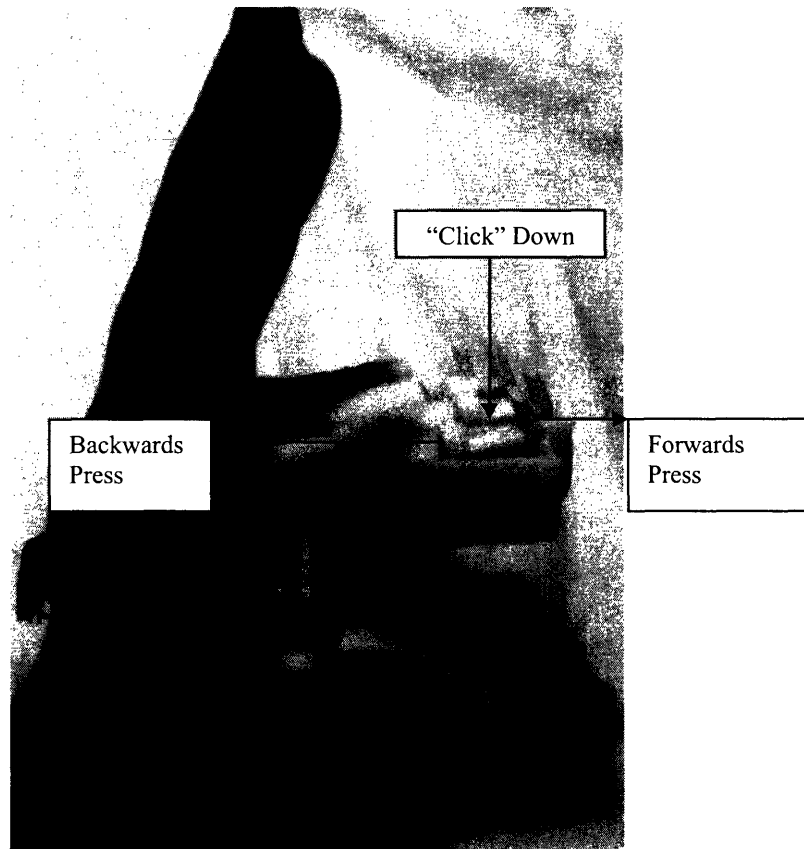

Figure 7: Key -press Direction

The finger interface slides onto and attaches to the metal lever of the Zippy Switch so that the finger can easily press the microswitch, or pull back or push forward to depress the other buttons. With this setup, one finger can give five distinct commands ('click', 'click and pull', 'click and push', 'pull' and 'push'). These commands can be mapped to mimic the operation of a QWERTY keyboard with 'click,' 'click and pull,' and 'click and push' corresponding to the middle (home) row, bottom row and top row respectively. When using the keyboard one-handed, the device is used as a half-QWERTY keyboard [22, 12, 23] with one of the thumb buttons being used as the mirror key. The only additional chording necessary in order to type the alphabet is for the letters t, g, and b (and their mirrored letters y, h and n). To type these keys the user can hold down the pinky key and press the appropriate index key (click-center, click-up or click-down). It is possible to achieve the other keyboard characters by using the 3 buttons per finger in various remaining key combinations. See Appendix A for a complete mapping.

The top and bottom caps for each key cover up the wiring and help to hold some of the buttons in place. The top cap is also an aesthetic aspect that transitions the shape of the finger interface to flow into the rest of the key body thereby making the keys look less chunky and boxy (Figure 8).

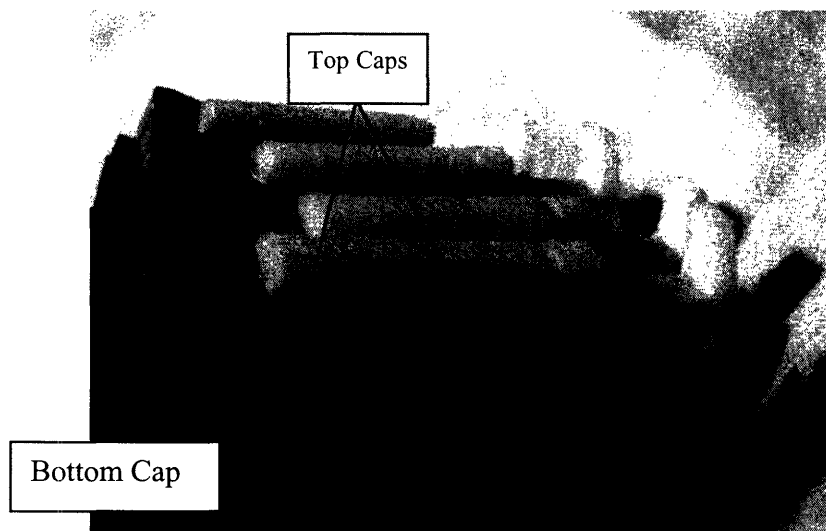

Figure 8: Top and Bottom Caps

The key body (with all the switches, wiring and caps) is the same for each finger, and attaches to a key-rod interface part. This interface part connects the key body to the main rotation axis. Each key-rod interface is a different length so that the finger interface is the correct distance from the palm of the hand for each finger (Figure 9).

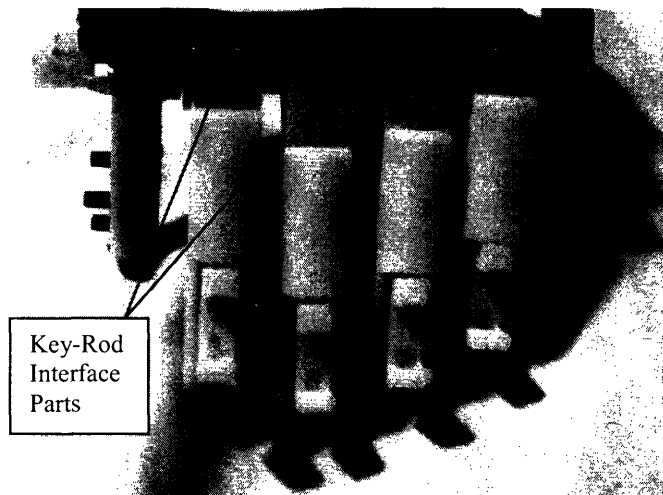

Figure 9: Varied Lengths of Key-Rod Interface Parts

The thumb key rotates on a separate axis from the rest of the keys. It contains 3 E-Switch #TL1105BF160Q Momentary Tact Switches that are arranged so that the thumb can press them individually or in any combination. This allows the thumb to be used for keys like “return,” “ctrl,” “shift” etc. in addition to the space and mirror key. When folded, the thumb key takes on the profile of the body of the keyboard so that it doesn’t add to the overall thickness of the device.

4.3 The folding and locking mechanism

The folding bar shown in Figure 10 rotates around the main axis rod along with the four finger keys. Each key is attached to the folding bar with a screw and spring so that all four keys rotate and lock in position together, but are still individually adjustable (Figure 11). The folding bar is locked in place by using a stopper that mechanically interferes with its rotation. The stopper is fixed to the thumb rod, which, when pushed axially, slides the stopper away from the leg of the folding bar allowing it to rotate freely. A spring pushes the stopper back against the folding bar leg so that when it reaches its position, it clicks in to place and locks again. When moving from the closed to open position, a torsion spring pushes the keys out into their open position (Figure 12).

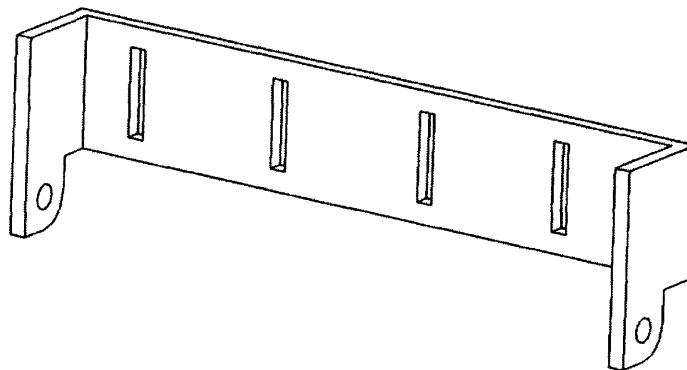

Figure 10: Folding Bar

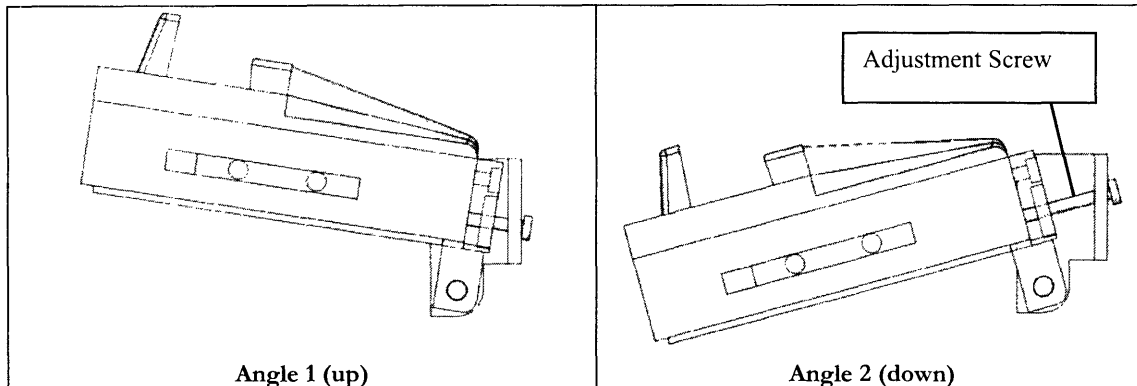

Figure 11: Angle Adjustment

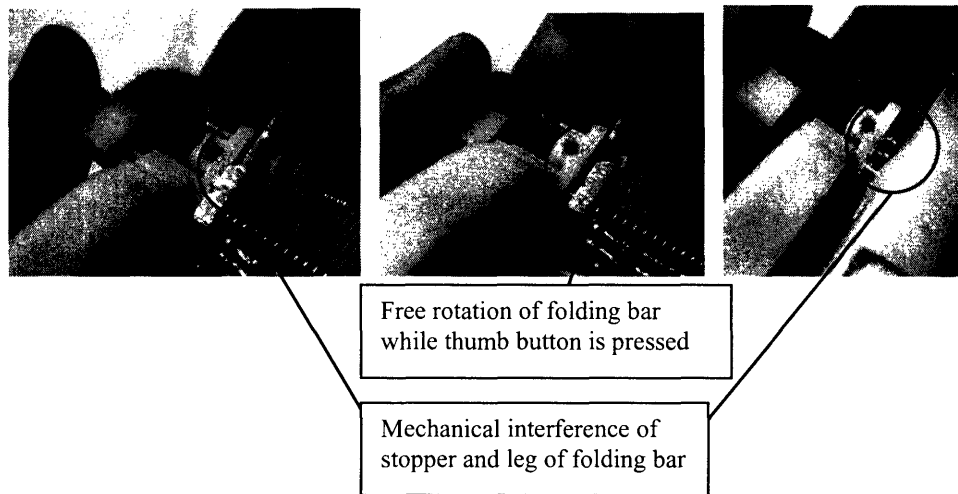

Figure 12: Locking Mechanism

4.4 Assembly/Body

The current design is held together on a flat base (shaped, as previously mentioned, to fit the hand). Two rod holders are screwed to this base to hold the main axis and thumb rods in place - all the keys are attached to these rods (Figure 13). The base has space for the thumb key to rotate as well as an opening for easy access to the battery for the wireless chip (Figure 14). The entire piece is capped in order to protect and hide the wiring and internal mechanisms. The strap is riveted to the base on one end and slides through a slot at the other end so that it is adjustable.



Figure 13: Internal Component Assembly

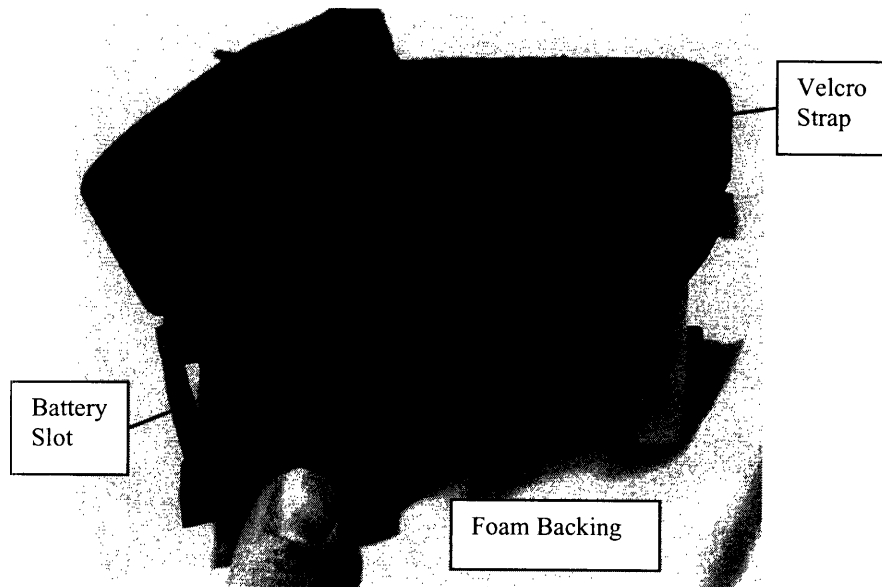

Figure 14: Battery Access

4.5 Mass Manufacturing

Bringing this device to market would involve some redesign to take advantage of manufacturing processes and improve assembly. In particular, injection molding many of the parts would be a low-cost way to make complex shapes to close tolerances using a strong material. With this technique many features could be combined into one part, which would simplify assembly. Injection molded parts will also make the device look and feel more like a professional product.

To accomplish this the base part would be redesigned to incorporate the functionality of the rod holders, and the folding bar would include protrusions that would function as the main axis rod. The folding bar would also be enlarged to surround the key bodies. These would be changed to fit within the folding bar and the rod interface

part could be eliminated. The folding bar and base would each have one solid cap to cover the electronics. All these parts would be injection molded and the only additional parts would be the springs, electronic components, and parts for the locking mechanism.

These changes would first be tested with a 3d-printed version that would show the fit and spatial relations, but would not be structural. After this, injection molded parts can be ordered to construct the next generation prototype, which can be used in testing to determine the next set of design changes.

The bulk of the manufacturing complexity is in the irregular shape of the injection-molded parts. The cost for making these parts is concentrated into the initial cost of making the mold, which is then reused many times. Therefore, in bulk, the parts are not significantly more costly than other injection molded parts of similar volume. The rest of the device consists of some simple switches, springs and a wireless chip. All together, the device is no more complex than an electronic toy, so it could probably retail for 30-60 dollars.

One special issue for the manufacture of this device is its size. Since this product is designed to fit multiple aspects of hand geometry, it is important that a person uses one with the appropriate dimensions for his or her hand [24]. People are used to this concept with clothing and other personal affects, but not with electronics. Since the key positions are adjustable, a few different sizes (i.e. small, medium and large) should cover most of the range of adolescent to adult hand sizes. This should be fairly to manufacture. The base and folding bar would have to be changed for the different widths and finger spacing, but rest of the components can be the same for all sizes.

For marketing, customizability is important. Since people are already choosing between different sizes, various color options and strap options would be offered – perhaps as interchangeable parts. Possibilities include a spandex strap for a sporty look, or leather for classier or everyday looks. Incorporating customizable parts and changeable straps relates the keyboard to products like watches, which are personal accessories [24]. Getting consumers to think of the keyboard as a personal accessory facilitates the transition of sized and personalized products from clothing to computation.

5. Analysis

The proposed device satisfies a few functional requirements that previous prototyped or commercial hand-held keyboards do not. This is due to the unique features incorporated into the design. One of these features is the key set up. The keys are arranged so that each finger can control three buttons at one interface point. They are also designed to reach the fingers in their natural, curved position. This satisfies some of the comfort FRs by being accessible and not requiring the fingers to move to hard to reach buttons. The key setup also lets users transfer existing typing skills by providing a way for the QWERTY layout to be emulated.

Another unique feature is the size of the device. It is designed to fit in the palm and only minimally extend beyond the width of the hand. Additionally, the keys fold down to the base to minimize the width. The size and folding features allow use of the typing hand while the keyboard is folded up or stored in a pocket. It also means that pocket storage is comfortable, and, when use is desired, it can be taken out or simply unfolded quickly. Finally, the small size provides a visual improvement over other hand held keyboards – it is discreet both while being used and while stored.

This general evaluation is based on initial observations and assessment of the overall form factor. The next step in the product development would be to construct a few prototypes and conduct user tests. These tests should have two goals. The first is to evaluate the device based on the Functional Requirements listed in Tables 2 through 5. This would involve letting people have some time to work with the device and then conducting interviews. Part of these interviews would include asking them to perform specific tasks with the device – typing and otherwise. The other goal is to specifically evaluate the user’s ability to actually type on the device. Speed tests are probably not appropriate at this point, as it is important to first evaluate the feel of the keys with the forward and backward pushing action. With this feedback, new key designs can be created and speed and accuracy tests can begin.

6. Conclusion

The prototype design, despite its lack of user testing, has proved a good tool to help determine which features necessitate significant re-evaluation. It also provides a proof-of-concept for future work to be built upon.

6.1 Future Work

The main feature that needs the most reconsideration is the forward pushing action in the main keys. It is difficult to use the current finger interface to push on the front button. Part of this difficulty is because the interface doesn’t provide a direct translation of the force. Pushing on the finger interface creates a torque around the front pin that makes it difficult for the main switch to slide. The best way to solve this is to reconfigure the spatial relationship between the finger interface and the main switch. It’s also possible that replacing the E-Switch #TL1105SPF100Q Momentary Tact Switch with other E-Switch buttons that are varied in some slight way (stroke length or force) would improve the problem. A longer stroke will give a better tactile feedback and a longer button would accommodate for forces that aren’t completely axial. There are also ways to redesign the entire key mechanism to be more reliable, have a better feel and take less space – a couple examples are shown in Figure 15.

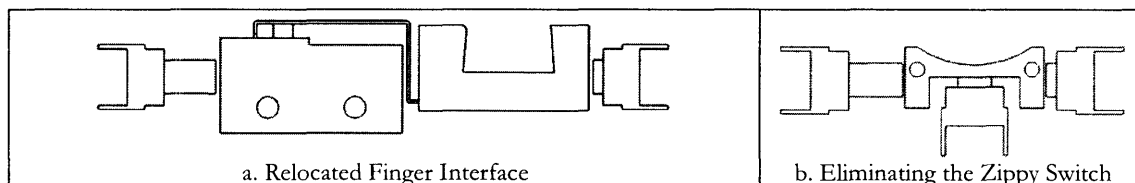

Figure 15: Alternative Key Designs

The other important issue that needs to continue to be improved upon is the size of the keyboard. The more compact it can be while folded up, the more likely people will be comfortable carrying or wearing the device throughout the day. This will let them always have quick access to their keyboard if they want to jot down notes from a spontaneous conversation or send a quick message.

The simplest components to shrink are the keys. Currently they take more than half of the width of the device when it’s folded up. This is because the Zippy microswitch is tall and the finger interface component is inserted on top of this. A quick

solution would be to extend the metal lever and reposition the finger interface to be inline with the switch (figure 15a). A better solution would be to find or custom design a thinner switch that possibly incorporated the functionality of the current three-button setup.

Another important component to change for reducing the size is the thumb key. Currently it is no thicker than the base while folded, but changing the location and folding mechanism will provide more thumb mobility when the device is folded up and not in use.

Eventually a pointing device and display should be incorporated into the keyboard. A couple of simple pointing solutions would be an optical mouse embedded into the bottom near the pinky, or a directional joystick-like button on the thumb key. At first a one-line display would suffice so that users could see the most recent text as they type. Eventually full cell-phone and PDA functionality would be incorporated into the device and a full PDA-sized display would be desirable (figures 16 and 17).

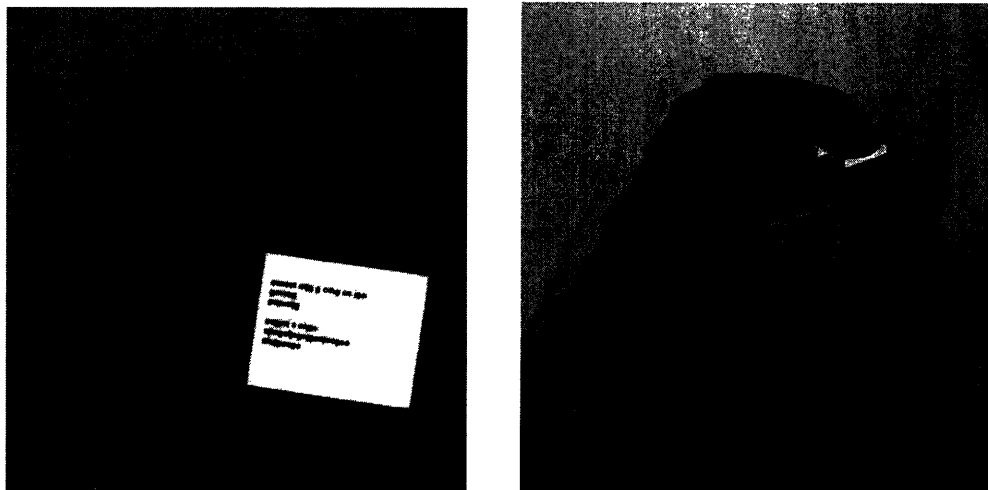

Figure 16: Renderings of Next Generation Prototype



Figure 17: Simplified Cross-Section of Next Generation Prototype (Folded)

6.2 Summary and Implications

Prior research has shown the schism between the poor performance of current popular methods for mobile text entry and the desire for using portable computation for text-based applications (such as text messaging). Many solutions have been developed, but none have been widely adopted. The device proposed in this paper attempts to improve upon the current standards of mobile text entry while solving the issues that have prevented popular acceptance of other hand-held products.

The functional requirements that the device satisfies show that it combines the functionality of the current hand-held standards (such as the Twiddler) with the size convenience (good looks and easy storage) of a cell phone or PDA while possibly being more comfortable to use than either.

Furthermore, the keyboard was designed so that it can mimic the half-QWERTY keyboard with one device, or can mimic the full QWERTY keyboard for improved speeds with one device in each hand. It could also replace the standard desktop keyboard to provide relaxed and mobile typing on a PC. This is an ergonomic improvement that existing QWERTY keyboards don't address. Instead of keeping the hands, wrists and body in a static but non-forced position, it eliminates unwanted, prolonged rigidity.

The large-scale adoption of such a device would allow for changes in the way people interact with computers – particularly in a public setting. The desktop keyboard would no longer be a standard part of a computer since everyone would have his or her own personalized input device. Because the device would incorporate the functionality of a mobile phone and PDA, people would always carry them (much as people today carry their cell phones). The devices would also become useful for communicating with public computational kiosks. They would be used at the ATM, filling out electronic forms at the hospital, registering at a hotel or any other situation where information needs to be communicated.

References

1. Canesta keyboard. Canesta, Inc. Available at <http://www.canesta.com/canestakeyboard.htm>. Accessed May 15, 2005.
2. Clarkson E, Clawson J, Lyons K, Starner T. An empirical study of typing rates on mini-QWERTY keyboards. In *CHI '05*: 1288-1291.
3. CTIA semi-annual wireless industry survey. CTIA – The wireless association. Available at http://www.ctia.org/research_statistics/index.cfm/AID/10030/. Accessed May 15, 2005.
4. Digital photo gallery: Number. Webster's Online Dictionary. Available at <http://www.websters-online-dictionary.org/definition/number>. Accessed May 15, 2005.
5. Ednet computer accessories. Ednet. Available at <http://www.ednet-ag.de/>. Accessed May 15, 2005.
6. Fastap keypads redefine mobile phones. Digit Wireless. Available at <http://www.digitwireless.com>. Accessed May 15, 2005.
7. Friedman, G. One-hand position-independent typing and data entry. The Data Egg. Available at <http://xaphoon.com/dataegg/>. Accessed May 15, 2005.
8. Fukumoto M, Tonomura Y. "Body Coupled FingerRing": Wireless wearable keyboard. In *CHI '97*: 147-154.
9. Goldberg D, Richardson C. Touch-Typing with a stylus. In *INTERCHI '93*: 80-87.
10. Goldstein M, *et al.* Non-Keyboard QWERTY touch typing: A portable input interface for the mobile user. In *CHI '99*: 32-39.
11. Gopher D, Raij D. Typing with a two-hand chord keyboard: Will the QWERTY become obsolete? *IEEE Transactions on systems, man and cybernetics*. 1988; 18(4): 601-609.
12. Half Keyboard. Matias Corporation. Available at <http://www.matias.ca/>. Accessed May 15, 2005.
13. Hargreaves W. *et al.* Toward a more humane keyboard. In *Proc. CHI '92*: 365-368.
14. Isokoski P, Raisamo R. Device independent text input: A rationale and an example. In *Proceedings of the Working Conference on Advanced Visual Interfaces 2000*: 76-83.

15. James C, Reischel K. Text input for mobile devices: Comparing model prediction to actual performance. In *CHI 2001*: 365-371.
16. Latest Mobile, GSM, Global, Handset, Base Station and Regional Cellular Statistics. CellularOnline. Available at: <http://www.cellular.co.za/>. Accessed May 15, 2005.
17. Lee S, Hong S, Jeon J. Designing a universal keyboard using chording gloves. In *CUU '03*: 142-147.
18. Lueder R, Grant C. Alternative Keyboard Designs. *Ergonomics review: Keyboards*. National Institute of Occupational Safety and Health, Ergonomics Branch; June 16, 1997.
19. Lyons K, *et al.* Twiddler typing: One-handed chording text entry for mobile phones. In *CHI 2004*: 671-678.
20. Lyons K, Plaisted D, Starner T. Expert chording text entry on the Twiddler one-handed keyboard. In *Proc. of SIGCHI conference on human factors in computing systems 2004*: 671-678.
21. MacKenzie I, Soukoreff R. Text entry for mobile computing: Models and methods, theory and practice. *Human-Computer Interaction*. 2002; 17: 147-198.
22. Matias E, MacKenzie I, Buxton W. Half-QWERTY: A one-handed keyboard facilitating skill transfer from QWERTY. In *INTERCHI '93*: 88-94.
23. Matias E, MacKenzie I, Buxton W. One-Handed touch-typing on a QWERTY keyboard. *Human-Computer Interaction*. 1996; 11: 1-27.
24. McKown, J. Yet another one-hand keyboard. Available at <http://www.chordite.com>. Accessed May 15, 2005.
25. Myers B, Lie K, Yang B. Two-Handed input using a PDA and a mouse. In *CHI 2000*: 41-48.
26. Nesbat, S. A system for fast, full-text entry for small electronic devices. In *ICMI '03*: 4-11.
27. palmOne keyboards and other accessories. palmOne, Inc. Available at <http://www.palmone.com/us/products/accessories/peripherals/>. Accessed May 15, 2005.
28. palmOne product basics. palmOne, Inc. Available at <http://www.palmone.com/us/products/input/>. Accessed May 15, 2005.

29. Pavlovych A, Stuerzlinger W. Less-Tap: A fast and easy-to-learn text input technique for phones. *Graphics Interface 2003*: 97-104.
30. Rosenberg R, Slater M. The chording glove: A glove-based text input device. *IEEE Transactions on systems, man and cybernetics*. 1999; 29(2): 186-191.
31. Senseboard – the current version. Senseboard Technologies. Available at <http://www.senseboard.com/product.php>. Accessed May 15, 2005.
32. Silfverberg M, MacKenzie I, Korhonen P. Predicting text entry speed on mobile phones. In *Proc. CHI 2000*: 9-16.
33. Sirisena A. Mobile Text Entry. *Honors Project: Department of Computer Science, University of Canterbury*. Christchurch, New Zealand; 2002.
34. Starner T, Snoeck C, Wong B, McGuire R. Use of mobile appointment scheduling devices. In *CHI 2004*: 1501-1504.
35. T9 predictive text input. T9. Available at <http://www.t9.com/>. Accessed May 15, 2005.
36. Tapia E, Marmasse N, Intille S, Larson K. MITes: Wireless portable sensors for studying behavior. In *Proceedings of Extended Abstracts Ubicomp 2004*.
37. The New CyKey. Available at <http://www.bellaire.demon.co.uk/newcykey.htm>. Accessed May 15, 2005.
38. The Twiddler 2. HandyKey Corporation. Available at <http://www.handykey.com>. Accessed May 15, 2005.
39. Willner M. Alphagrip white paper. Alphagrip, Inc. Available at <http://www.alphagrip.com/WhitePaper.html>. Accessed May 15, 2005.
40. Zabrek, E. Sprint's two new phone editions. *Pocket PC Magazine*. 2003; September. Available at <http://www.pocketpcmag.com/archives/Sep03/sprint.asp>. Accessed May 15, 2005.

Appendix A: Proposed Key Mapping Using Half-QWERTY

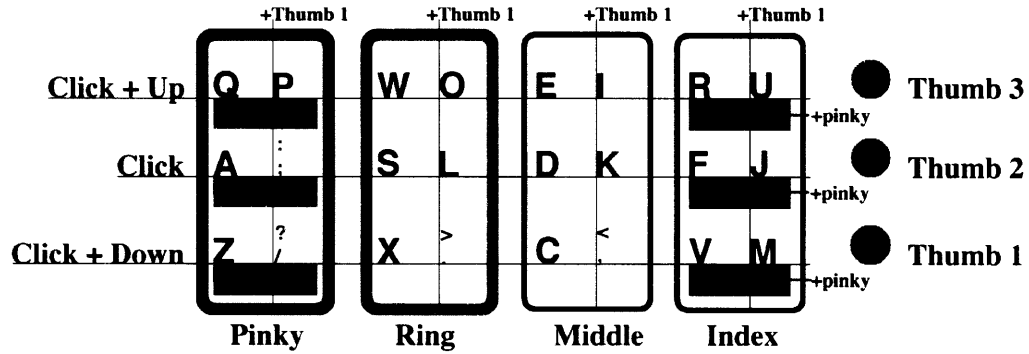

Other Standard QWERTY Keyboard keys:

Character	Key Mapping*
1	Id
2	Md
3	Rd
4	Pd
5	Iu
6	Mu
7	Ru
8	Fu
9	Id + Md
0	Rd + Pd
Space	Thumb 1
Shift	Thumb 2
Ctrl	Thumb 3
Alt	Thumb 1 + Md
OS Key	Thumb 1 + Id
Tab	Thumb 1 + Rd
Esc	Thumb 1 + Pd
(F1, F2, F3, F4, F5, F6)	Id + (Md, Rd, Pd, Mu, Ru, Pu)
F7-F12	Iu + (Md, Rd, Pd, Mu, Ru, Pu)

*Legend:

Index, Middle, Ring, Pinky = I, M, R, P

Index Up, Index Down, Middle Up, Middle Down, etc. = Iu, Id, Mu, Md, etc.