

Linear to Non-linear Rheology of Wheat Flour Dough

Trevor S.K. Ng, Gareth H. McKinley, and Mahesh Padmanabhan

February 2006
HML Report Number 06-P-08

Linear to Non-linear Rheology of Wheat Flour Dough

Trevor S. K. Ng, Gareth H. McKinley

Hatsopoulos Microfluids Laboratory, Dept of Mechanical Engineering, Massachusetts Institute of Technology, Cambridge, MA 02139, USA

Mahesh Padmanabhan

Kraft Foods Global Inc., 801 Waukegan Road, Glenview, Illinois 60025, USA

We provide an overview of transient extensional rheometry techniques for wheat flour doughs in which the deformation and material response is well defined. The behavior of a range of model doughs was explored with a Filament Stretching Extensional Rheometer (FISER). The measurements were also compared to data obtained with a new wind-up extensional rheometer; the SER universal testing platform. A simple empirical constitutive equation, which allows characterization of the experimental results with a small number of parameters, is presented to describe the resulting measurements. To characterize the relaxation modulus of the doughs, small amplitude oscillatory tests were performed on samples that have been shear-mixed in a mixograph for varying lengths of time. The linear viscoelastic properties were found to exhibit a broad power-law dependence on the imposed oscillatory frequency that is very reminiscent of that exhibited by a critical gel. The critical gel model of Winter-Chambon [1, 2] was used as the basis for constructing a non-linear constitutive equation for the material stress by combining the relaxation modulus for the critical gel with a Lodge rubber-like liquid form for the kinematics. Transient uniaxial extensional data recorded from the FISER and SER instruments were then compared to the predictions of the constitutive equation. The model captures the initial power-law response and subsequent strain-hardening; however additional physics is required to describe the rheological phenomena at very large Hencky strains, including finite extensibility effects and filament rupture in extensional flows.

Keywords: Extensional rheology, filament stretching, strain-hardening, damping function, gel equation:

1 INTRODUCTION

Breadmaking is a process in which large extensional deformation of the dough feature prominently. During mixing and kneading, dough is stretched by hand or by specially designed mixing machines, while in proofing and baking, the expansion of gas cells cause significant extensional strain on the surrounding dough. In view of this, it is not surprising that there have been a number of studies suggesting a link between baking quality and the extensional rheological properties of the dough. Bloksma [3] outlined two requirements for producing high quality loaves: "1) the dough must have sufficiently large viscosity to prevent the ascent of gas cells, and 2) it must remain extensible for a long enough time during baking to avoid premature rupture of membranes between gas cells." Bloksma concluded that the first condition is met by virtually all doughs while the second can serve as a discriminator for flours of different baking performance. Extensibility stems from the quality and quantity of protein in the flour [4, 5]. Physically, large molecular weight protein molecules known as glutenin form an elastic network capable of strain-hardening under extension and gives stability under large extensional strain.

One of the first comprehensive studies on dough was performed by Schofield and Blair [6-9]. By employing a range of primitive but ingenious rheometers ("the rack", the pachymeter etc...), they were able to measure various visco-elastic functions of the dough. Subsequently, a wide range of test

methods are employed for systematically characterizing the extensional rheology of dough [10], in an attempt to link protein quality/content, molecular extensibility and macroscopic strain-hardening. Today, common extensional tests can be separated into two categories, uniaxial and biaxial extension test rigs. Devices of the uniaxial extension type include Extensigraphs, Instrons and other mechanical testing systems [4, 11-15], while examples of biaxial extensional devices include Alveographs, and squeeze flows that induce uniaxial compression [5, 16-20].

It is well known that dough is a viscoelastic material. Therefore it is surprising that most studies of its extensional rheology have been confined to a single or a limited range of strain rates. These strain rate are also often far larger than those associated with bread making. The reason being that it is extremely difficult to maintain regular extensional deformation at the slow rates characteristic of bread making. Baking typically features strain rates of the order $\dot{\epsilon} \sim O(10^{-3} \text{ s}^{-1})$, while proofing leads to even slower deformations with $\dot{\epsilon} \sim O(10^{-4} \text{ s}^{-1})$ [3].

Overall, dough presents numerous experimental and conceptual challenges to the rheologist [21]. Issues such as long relaxation times and sample drying makes forming a consistent sample with good reproducibility extremely difficult. The viscoelastic properties are also sensitive to composition. Methods such as the water-correspondence principle and corrections for rheological ageing are extremely useful in making sense of the data

¹ Corresponding author: gareth@mit.edu

collected from a range of conditions [22-25].

In this article we present experimental measurements of the transient elongational rheology obtained with two techniques, the Filament Stretching Rheometer (FISER) and the SER universal testing platform. Special experimental protocols and modifications to the standard rheometer fixtures used with these devices are needed to overcome difficulties in sample preparation. In both of these devices, the sample approaches uniform uni-axial extension flow at a constant strain rate over a large portion of its length. The large dynamic range of these rheometers allows us to probe the visco-elastic nature of the dough at high rates as well as deep into the baking/proving range.

2 EXPERIMENTAL TECHNIQUES AND THEORETICAL BACKGROUND

2.1 Filament Stretching Rheometry

The Filament Stretching Rheometer (FISER) [26-29], has a large dynamic range (imposed strain rates of $0.001 \leq \dot{\epsilon} \leq 5s^{-1}$ are possible), can produce good accuracy and reproducibility in tensile force measurements and is able to monitor (in real-time) the evolution of the mid-plane diameter of the elongating filament during the experiment. We can define two measures of the deformation history that characterize the experiment. Firstly, the nominal strain-rate imposed:

$$\dot{E} = \frac{1}{L} \frac{dL(t)}{dt} \quad (1)$$

where $L(t)$ is the overall filament length, and the corresponding strain $E = \dot{E}t$ based on the displacement of the endplates. Secondly the

measured or *true* Hencky strain $\epsilon(t) = \int_0^t \dot{\epsilon}_{mid}(t') dt'$

based on the actual deformation rate experienced at the axial midplane:

$$\dot{\epsilon}_{mid}(t) = \frac{d\epsilon(t)}{dt} = -\frac{2}{D_{mid}(t)} \frac{dD_{mid}(t)}{dt} \quad (2)$$

where $D_{mid}(t)$ is the diameter measured by the laser micrometer at the midpoint of the filament. Under large strains the axial profile of a stretched dough filament is often not uniform. Independently and directly measuring the deformation at the midplane (for example using a laser micrometer or video imaging system) thus gives us more accuracy in calculating rheological parameters such as the true tensile stress and true Hencky strain. It also allows us to study the growth of defects that lead to axial non-uniformity and ultimately rupture.

Dimensional analysis [27, 28] indicates that the effects of gravity, surface tension and inertia are all

negligible for dough samples in a filament stretching device, the true tensile stress is then simply given by:

$$\sigma_{zz} - \sigma_{rr} = \frac{4F(t)}{\pi D_{mid}^2(t)} \quad (3)$$

Cylindrical samples were prepared by compressing the dough between circular end-plates and trimming off the excess dough with a "cookie-cutter". Sandpaper was used to improve adhesion at the end-plates. Oil was applied to exposed ends of the dough to minimize drying during resting and testing.

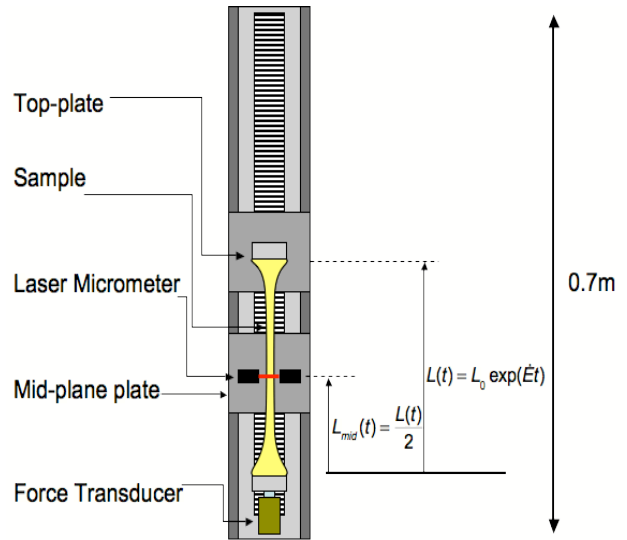

Figure 1 Schematic of the FISER. The top plate separates exponentially from the bottom plate to create a nominally constant strain rate in the elongating sample. The diameter of the sample is measured at the mid-plane using a laser, while a stationary force transducer on the bottom plate measures the tensile force in the stretching column.

2.2 SER Method

An alternative technique to examine the uni-axial extensional response of doughs is the Sentmanat Extensional Rheometer (SER) [30-32]. Samples are prepared by pressing and cutting the dough into rectangular sheets of known initial dimensions. The sheets were coated with a layer of silicone oil to prevent drying and then mounted onto two cylindrical drums as shown in Figure 2. The two drums are interconnected with a gearing system [30-32] to counter-rotate and stretch the sample.

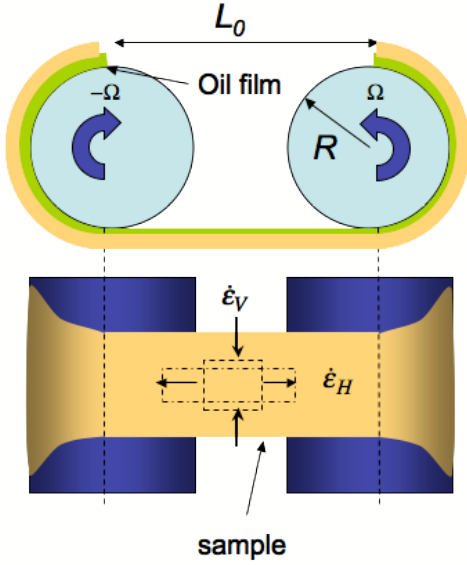

Figure 2 Schematic of the Sentmanat Extensional Rheometer. Sample is stretched between two counter rotating cylindrical drums.

The tension F within the sample can be inferred from the torque T acting on the drums.

$$F \approx T/2R \quad (4)$$

The nominal extensional strain rate in the horizontal direction (H) is given by:

$$\dot{E}_H = 2\Omega R/L_0 \quad (5)$$

where Ω is the rate of rotation of a drum and L_0 is the distance between the axis of the two drums (Figure 2). In existing work with the SER, the deformation has always been assumed to be a purely affine uni-axial deformation such that $\dot{\epsilon}_H = \dot{E}_H = -2\dot{\epsilon}_V$ (where V and H are the vertical and horizontal directions respectively as shown in the figure). However the layer of low viscosity oil coating the dough can lead to partial slip between the sample and the drums. It is thus essential to directly measure the true deformation rate in the sample. Similar systematic differences between the imposed and actual deformation rates are well-known in other extensional rheometer designs that use strips of viscoelastic material [33]. As shown in Figure 3, we use an initially rectangular grid that is painted onto the dough to follow the homogeneity of deformation with high speed digital video. After correcting for the fluid slip the resulting strains were found to indeed approximate uni-axial elongation but at a strain rate 25% slower than the nominal rate.

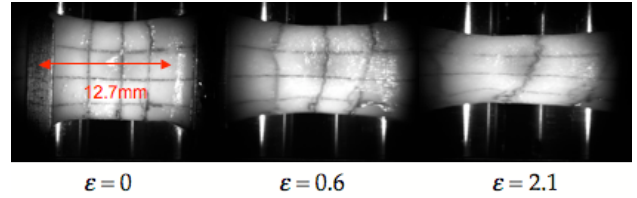
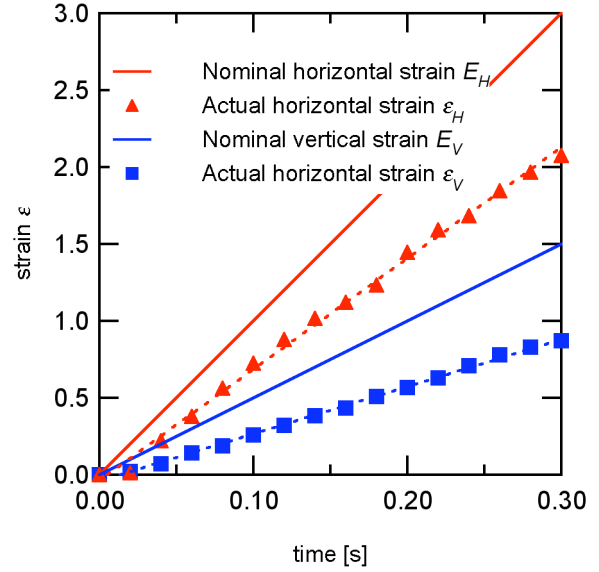

Figure 3 Deformation of a dough sample on the SER at $\dot{E} = 10\text{s}^{-1}$. Slip leads to an actual deformation rate in the sample that is $\sim 25\%$ slower than the nominal imposed value; however the strains remain approximately uni-axial. True strains were calculated by measuring the change in length of material lines marked on the surface of the undeformed dough sample.

Results obtained from this method are found to be in good agreement to data from filament stretching (Figure 4).

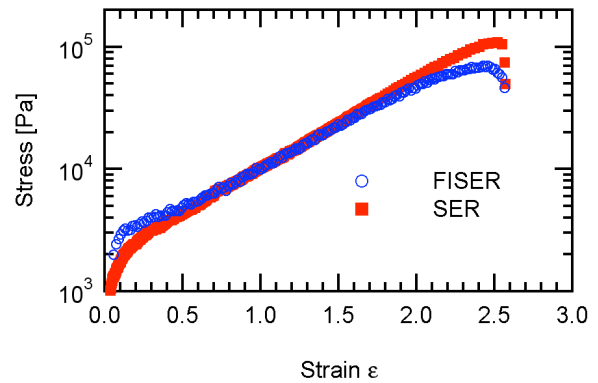

Figure 4 Comparison of extensional behavior of a wheat flour dough recorded on the FISER vs SER at $\dot{E} = 0.3\text{s}^{-1}$.

2.3 Critical Gels under large deformations

The linear viscoelastic properties of doughs have been well studied in the past and are known to contain a very broad spectrum of relaxation

processes [25, 34-36]. Recently it has been suggested by de Cindio and co-workers [37] that a simple way of describing the linear visco-elastic properties is through the critical gel model of Winter and Chambon [1, 2]. To describe the corresponding non-linear properties in large straining deformations we construct a rheologically admissible constitutive equation of Lodge rubber-like liquid form by combining the linear viscoelastic relaxation modulus of the critical gel with finite strain kinematics.

At the critical gel point, the stress relaxation modulus follows a power-law-like decay and is described by the gel equation:

$$G(t) = St^{-n} \quad (6)$$

Where S is the gel strength and n is the gel exponent. With the appropriate Fourier transformation, one can show that the linear viscoelastic response in an oscillatory shear flow also behaves in a power-law fashion:

$$G'(\omega) = \frac{G''(\omega)}{\tan(n\pi/2)} = \Gamma(1-n)\cos(n\pi/2)S\omega^n \quad (7)$$

Where $\Gamma(n)$ is the gamma function. With the appropriate finite strain measure and using the Lodge Rubber-like Liquid description for the kinematics, the constitutive equation can be written as:

$$\sigma(t) = \int_{-\infty}^t G(t-t')\gamma_{[1]}(t,t')dt' \quad (8)$$

Where $G(t)$ is the relaxation modulus from (6) and $\gamma_{[1]}$ is the finite strain rate tensor, defined by:

$$\gamma_{[1]}(t,t') = \frac{\partial}{\partial t'}\gamma_{[0]}(t,t') \quad (9)$$

and $\gamma_{[0]}$ is the finite strain tensor [38]. The resulting set of equations (6) - (9) can be integrated for different kinematics to evaluate the tensile stress in the dough at large strains.

3 EXPERIMENTAL RESULTS

3.1 Extensional Rheology of Flour-Water Doughs

The transient extensional viscoelastic behavior was studied using filament stretching rheometry for a single type of strong wheat flour; mixed to a constant time (360s/peak-mixed) and a fixed water ratio by weight (66%). The strain-rate was varied over three orders of magnitude (3×10^{-3} to $3 \times 10^0 \text{ s}^{-1}$). Representative results are shown in Figure 5. By inspecting the accompanying images and comparing the true Hencky strain at the mid-plane to the imposed axial strain, we conclude the sample approaches uniform uniaxial deformation. This

regime of stable extension continues up to a certain critical point at which a localized necking event begins and ultimately leads to rupture.

At high strain rates, the stress increases more rapidly than linearly with the Hencky strain and we refer to this phenomenon as *strain-hardening*. On the other hand, at low rates, the shape of the curve is “convex”, or “strain-softening” and the stresses increase less rapidly than linearly with strain..

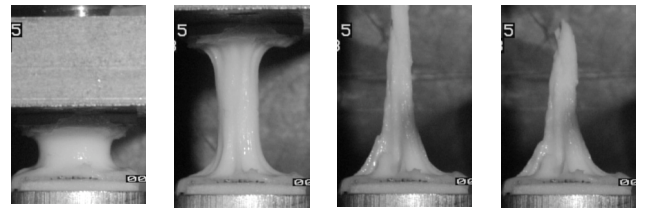
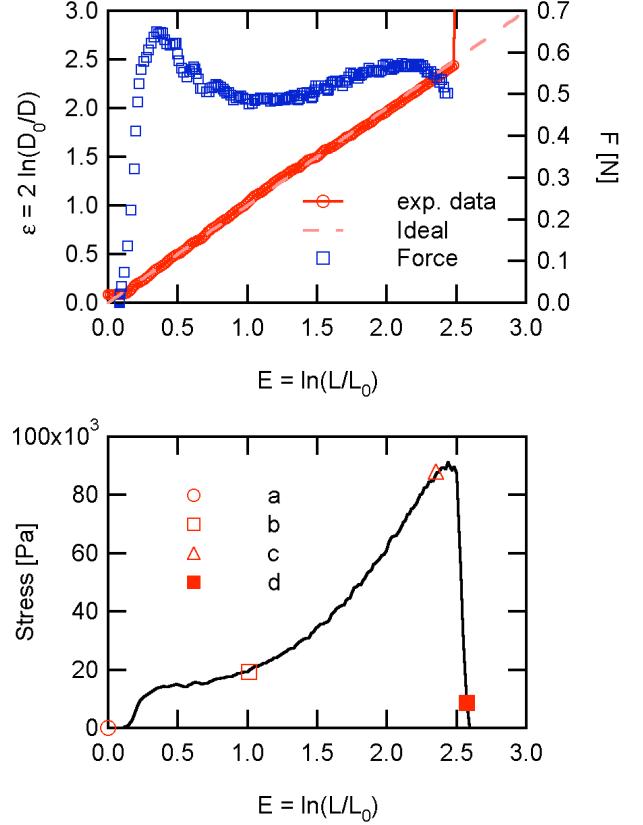

a. $E = 0$ b. $E = 1.0$ c. $E = 2.4$ d. $E = 2.6$

Figure 5. Typical data obtained from FISER for a strong flour dough). The upper figure shows the measured tensile force and total midplane strain (see eq. 2); the lower figure shows the computed evolution in the tensile stress. The labeled points indicate a. Large initial aspect ratio, no lubrication regime., b. Uniform uniaxial extension., c. Necking., d. Rupture.

At this point, we need a constitutive equation to describe the phenomena quantitatively. Various constitutive equations have been suggested to incorporate the complex response of dough, but they tend to be complex and unwieldy requiring a relatively large number of constants which have to be determined experimentally. Hence we first

introduce an empirical constitutive equation which provides a reasonable and simple pragmatic description of the measured visco-elastic response:

$$\sigma(\varepsilon, \dot{\varepsilon}) = H + G\varepsilon^c \quad (10)$$

where $H = H(\dot{\varepsilon})$ is a viscous off-set, the modulus is given by $G = G(\dot{\varepsilon})$ and $c = c(\dot{\varepsilon})$ is a strain-hardening index. It is important to note that this simple model is *not* frame invariant and is only applicable to true uniaxial extension. This equation is able to parameterize the measured stress-strain behavior of many doughs with reasonable accuracy using a manageable number of variables. A more detailed analysis with the gel equation is given in section 3.3. The index c captures the capability of the dough to strain-harden at different strain rates. A material with $c = 1$ behaves elasto-plastically with a rate-dependent yield stress H [39, 40] and the stress increasing linearly with strain.

Measurements at increasing deformation rates show that dough changes from a strain-softening to hardening behavior at higher-rates, and therefore c increases steadily through a value of unity. The deformation rate at which $c = 1$ can be obtained from interpolation and used to form a characteristic time scale τ for doughs in uni-axial elongation.

$$\tau = 1/\dot{\varepsilon}|_{c=1} \quad (11)$$

Since this time-constant arises from the strain-hardening behavior, we also expect it to be closely related to the appropriate time scale in the relaxation time spectrum that is important to extensional flow. The corresponding Deborah number for uniaxial elongation is then $De = \tau\dot{\varepsilon}$.

The transient nature of the filament stretching experiments allows us to monitor the properties of the dough all the way to the point of rupture. Results obtained from a number of doughs are shown in Figure 6. This highlights the importance of the visco-elastic character on the tensile properties of doughs such as the strain to rupture.

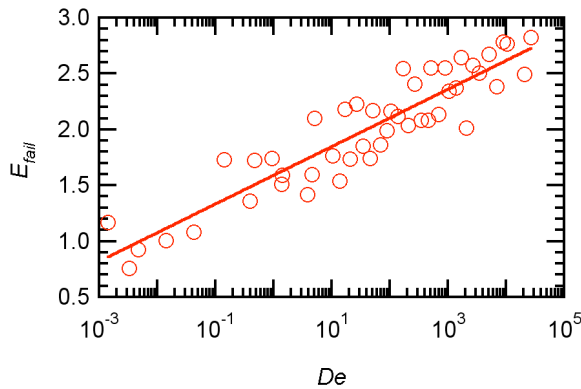

Figure 6 Non-dimensional plot of final failure strain (E_{fail}) vs Deborah number ($De = \tau\dot{\varepsilon}$) for a range of doughs.

3.2 Stability in uniaxial extension

Figure 6 demonstrates that there is an important empirical relationship between the extensibility of the sample (i.e. the strain to failure), the material properties of the dough (characteristic time scale) and the imposed deformation conditions (strain rate). The relationship between the various parameters can be rationalized through the *Considère Criterion* and an extended linearized analysis that incorporates rate dependence which was originally proposed by Hutchinson et al. [41, 42]. Both approaches are essentially linearized energy stability methods that focus on finding the maximum tensile force in the elongating filament.

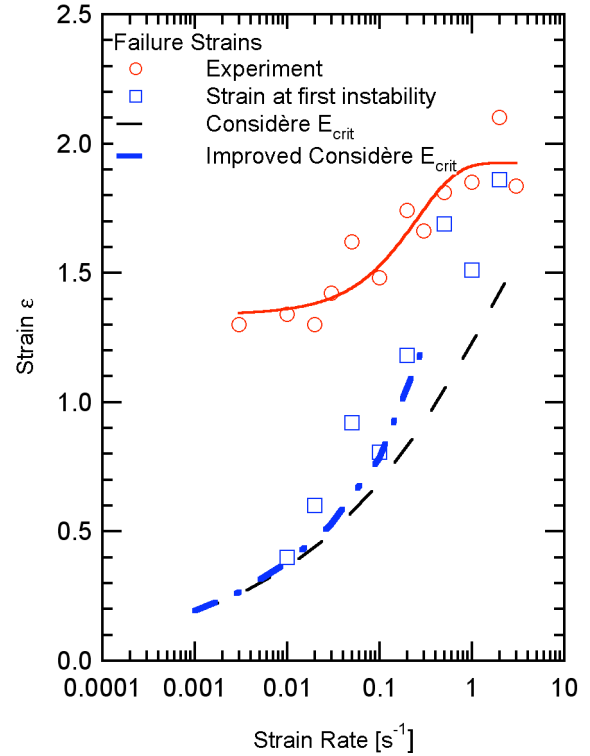

Figure 7. Two different measures of extensibility plotted against the imposed strain rate. Square symbols denote the point of first instability E_{crit} , open circles denote the final rupture strain E_{fail} . Dotted lines are predictions for onset of instability using two different criteria from Considère and from Hutchinson et al. The solid line shows the results of numerical computations.

As we show in Figure 7, these analyses are able to predict the *initial* point of necking instability (corresponding to the point (denoted by E_{crit}) of deviation from uni-axial extension) with reasonable success. However, as can be seen from Figure 5 an appreciable additional strain occurs between the onset of necking and the final failure or *rupture* event at E_{fail} . An accurate prediction of this final failure strain involves solving the non-linear differential equations that govern the evolution in the filament kinematics and stresses with a precise

description of the initial conditions. This obviously requires an accurate model for the viscoelastic stresses in the material. A representative result is shown by the solid line in Figure 7. In order to obtain quantitative agreement it is essential to be able to describe accurately the nonlinear evolution in the tensile stresses in the elongating dough filament over a wide range of strains and strain rates. This in turn requires the development of a robust constitutive model as we describe below.

3.3 Modeling Large Strain Deformations of Dough as a critical Gel

The linear viscoelastic response of a dough is very close to that of a critical gel [37, 43] as shown in figures 8a and 9a. In a stress relaxation test, the modulus decreases in a power-law like manner. In small amplitude oscillatory shear (SAOS), variations in the loss and storage moduli also follow a power-law relationship with frequency. This perhaps should not be surprising since many food stuffs are gels. Various researchers have come to the consensus that the glutenin macropolymer forms a three-dimensional network throughout the dough [44-46]. The initially distinct glutenin molecules in the flour swell in size due to hydration and begin to interact with neighboring glutenin molecules in the process of mixing/working. The large molecular weight of the glutenin macropolymer is essential to form a critical number of interactions. This gives rise to a sample-spanning structure that imbues the dough with its elasticity. This process can be viewed as a form of physical gelation.

The gel equation was initially developed to describe linear viscoelastic deformations. However, non-linear behavior becomes apparent in doughs even at relatively small strains ($\gamma \sim 10^{-3}$). We account for the decrease in modulus through a damping function $h(\gamma)$ as shown in Figure 8(b) & 8(c). The damping function can be described by the following expression:

$$h(\gamma) = \frac{1}{1 + q\gamma^{2k}} \quad (12)$$

where q , k are fitted constants. As mentioned in section 2.3, a Lodge Rubber-like Liquid form of the constitutive equation is used to describe the resulting stress. Under transient uniaxial extension (Figure 9b), the finite strain rate tensor takes the form:

$$\gamma_{[1]}(t) = \begin{bmatrix} -\exp(-\dot{\epsilon}t) & 0 & 0 \\ 0 & -\exp(-\dot{\epsilon}t) & 0 \\ 0 & 0 & 2\exp(2\dot{\epsilon}t) \end{bmatrix} \quad (13)$$

Substituting eq.(6) and eq. (13) into eq. (8) results in an integral equation for the stress field as a function of strain rate and elapsed time.

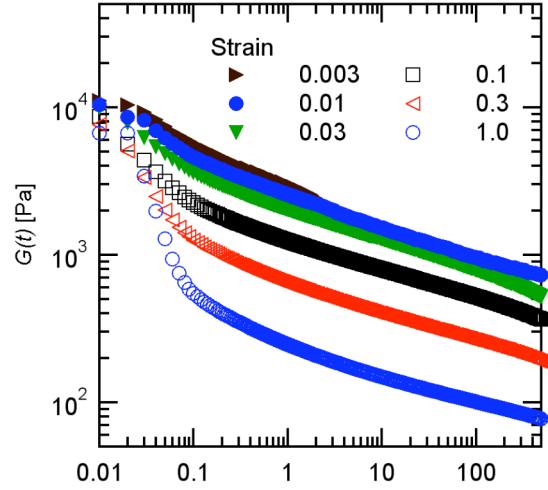

a.

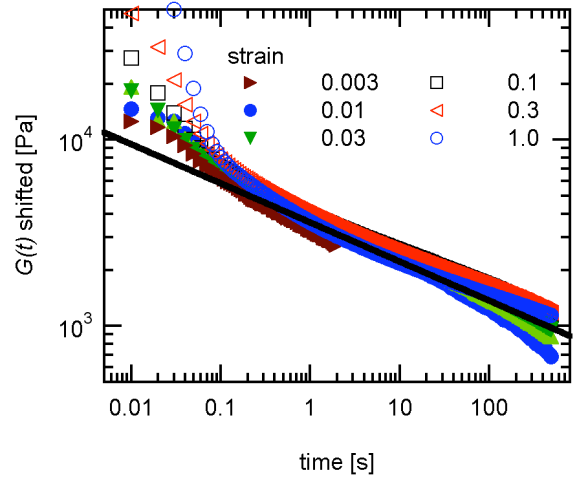

b.

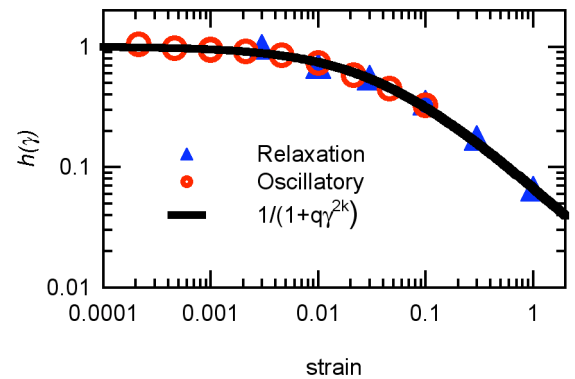

c.

Figure 8 a. Stress relaxation showing power-law-like behavior (stresses are shifted to account for rheological ageing). b. Stress relaxation curves can be scaled to lie on a single curve through a damping function. c. The damping function $h(\gamma)$ as a function of the imposed strain amplitude. $q = 13.51$, $k = 0.2$

With some algebra, the normal stress difference can ultimately be written compactly in the form of a summation:

$$\sigma_{zz} - \sigma_{rr} = S\dot{\epsilon}^n \sum_{m=0}^{\infty} \frac{2^m - (-1)^m}{(m-n)\dots(1-n)} \epsilon^{m-n} \quad (14)$$

The series converges rapidly, the first ten terms are typically sufficient for evaluating the stress difference up to Hencky strains of $\epsilon = 5$. It can be seen from Eq. (14) that the stress exhibits a power-law dependence on strain rate and a more complex dependence on strain. This expression is represented by the dotted lines in Figure 9b and c. We also note that Eq. (14) has an asymptotic limit in the form given by $(\sigma_{zz} - \sigma_{rr}) \sim \exp(2\epsilon)$ at large strains, i.e. an affine scaling in strain. After the rate dependence is factored out by dividing the measured stress by the known power-law dependence on the strain rate, experiments from a range of strain rates can be collapsed onto a single curve that defines a strain function $\Phi(\epsilon)$ of the following form:

$$\Phi(\epsilon) = (\sigma_{zz} - \sigma_{rr}) / (2^n S \dot{\epsilon}^n \Gamma(1-n)) \quad (15)$$

The function $\Phi(\epsilon)$ is shown Figure 9(c) and the experimental data suggest it is of simple exponential form. This *factorizability* of the rate-dependence in dough rheology is a consequence of the power-law dependence of the relaxation modulus on time t (see eq. 6) and is applicable to both shearing and extensional deformations.

Although the predictions of this Rubber-Like Liquid model (shown by the broken lines in Figure 9b and c) offers an improved description to the linear viscoelastic response, it clearly over-predicts the experimentally measured response. This relative strain-softening (as compared to a purely affine strain response) is due – presumably – to changes in the network structure with the progressive deformation and disruption of the physical crosslinks between the glutenin molecules and starch granules. An appropriate strain-softening or *damping function* can be used to account for this phenomenon. At large strains the stress appears to tend toward a simple exponential function $\exp(k\epsilon)$ as shown in Figure 9c by the black dotted line. An estimate of this damping function can be calculated from the ratio of the large strain approximations to the asymptotic limit of the integral gel model of Eq. (14).

Our ongoing work seeks to relate this elongational damping function to the strain-softening function found in shear through the appropriate strain invariants.

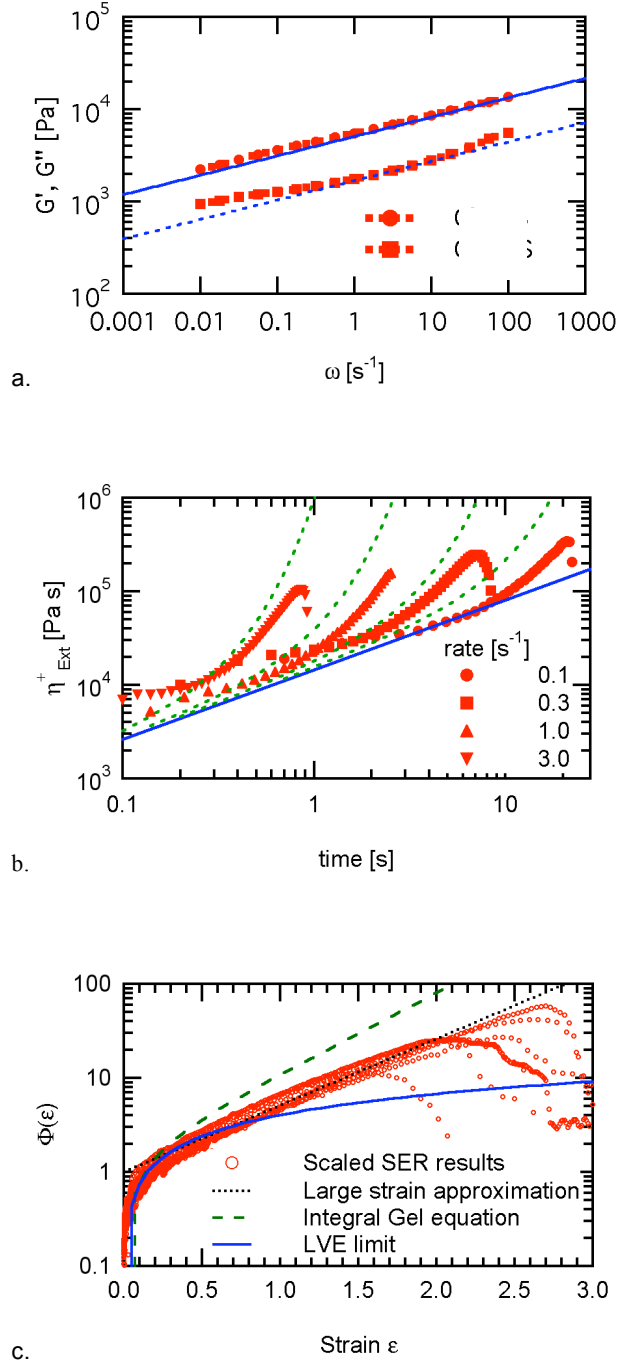

Figure 9. Critical gel-like behavior exhibited by a strong wheat flour dough: (a) in small amplitude oscillatory shear flows; solid lines are the fits from Eq. (7), $S=5060 \text{ Pa}\cdot\text{s}^n$, $n=0.21$; (b) in transient uniaxial extension. The broken line represents predictions using a Lodge Rubber-like liquid constitutive relation with the relaxation modulus determined from (a). The solid blue line marks the linear viscoelastic limit; (c) Guided by the gel equation scaling of Eq. (14), we factor out the strain-rate dependence. The remaining strain-dependent function $\Phi(\epsilon)$ is plotted on semilog axes. Experiments conducted at different strain rates now collapse onto a single curve. The dashed lines correspond to equation (14), the dotted line corresponds to an exponential of the form $\exp(k\epsilon)$ with $k=0.4$.

4 CONCLUSIONS

In this paper we have presented transient extensional rheometry measurements on model flour-water doughs results over a relatively large range of strain-rates. The experiments were performed on the Filament Stretching Rheometer (FISER) and the Sentmanat Extensional Rheometer (SER). The experiments highlight the important role of visco-elastic effects in both the transient stress evolution and the ultimate strain to rupture. The material response at low strain rates (10^{-3} s^{-1}) can be significantly different from that observed at relatively high rates (10^0 s^{-1}). It is therefore necessary to perform tests over a relatively large range of strain rates to in order to extract material parameters relevant to the breadmaking process. We first analyzed this data using a simple empirical constitutive equation. Even though rheologically inadmissible, we believe this approach is pragmatically useful in industry and yields relevant parameters that can differentiate between dough properties without involving cumbersome multi-variable expressions. We also observed striking similarity in the linear viscoelastic response between a critical gel and our model dough system. This led us to use the gel equation of Chambon and Winter as a starting point in formulating a rheologically admissible constitutive equation capable of describing finite deformations in shear (step strain) and elongation. The resulting predictions of the transient stress evolution in the deforming dough specimen are greatly improved; however the dough shows some additional strain softening at finite strains. Ongoing work seeks to describe arbitrary deformations using a strain-dependent damping function.

5 ACKNOWLEDGEMENT

The authors are grateful to Dr. Yongwoo Inn for technical discussions and input. The permission of Kraft Foods management for the publication of this work is also gratefully acknowledged.

6 REFERENCES

1. Chambon, F. and H.H. Winter, *Linear Viscoelasticity At The Gel Point Of A Cross-Linking PDMS With Imbalanced Stoichiometry*. *Journal Of Rheology*, 1987. 31(8): p. 683-697.
2. Winter, H.H. and F. Chambon, *Analysis Of Linear Viscoelasticity Of A Cross-Linking Polymer At The Gel Point*. *Journal Of Rheology*, 1986. 30(2): p. 367-382.
3. Bloksma, A.H., *Rheology of the Breadmaking Process*. *Cereal Food World*, 1990. 35(2).
4. Uthayakumaran, S., M. Newberry, M. Keentok, F.L. Stoddard, and F. Bekes, *Basic rheology of bread dough with modified protein content and glutenin-to-gliadin ratios*. *Cereal Chemistry*, 2000. 77(6): p. 744-749.
5. Dobraszczyk, B.J. and C.A. Roberts, *Strain-Hardening and Dough Gas Cell-Wall Failure in Biaxial Extension*. *Journal of Cereal Science*, 1994. 20(3): p. 265-274.
6. Schofield, R.K. and G.W.S. Blair, *The Relationship between Viscosity, Elasticity and Plastic Strength of Soft Materials as Illustrated by Some Mechanical Properties of Flour Doughs, I*. *Proceedings of the Royal Society of London. Series A, Containing Papers of a Mathematical and Physical Character*, 1932. 138(836): p. 707-718.
7. Schofield, R.K. and G.W.S. Blair, *The Relationship between Viscosity, Elasticity and Plastic Strength of a Soft Material as Illustrated by Some Mechanical Properties of Flour Dough. II*. *Proceedings of the Royal Society of London. Series A, Containing Papers of a Mathematical and Physical Character*, 1933. 139(839): p. 557-566.
8. Schofield, R.K. and G.W.S. Blair, *The Relationship between Viscosity, Elasticity and Plastic Strength of a Soft Material as Illustrated by Some Mechanical Properties of Flour Dough. III*. *Proceedings of the Royal Society of London. Series A, Containing Papers of a Mathematical and Physical Character*, 1933. 141(843): p. 72-85.
9. Schofield, R.K. and G.W.S. Blair, *The Relationship between Viscosity, Elasticity and Plastic Strength of a Soft Material as Illustrated by Some Mechanical Properties of Flour Dough. IV. The Separate Contributions of Gluten and Starch*. *Proceedings of the Royal Society of London. Series A, Mathematical and Physical Sciences*, 1937. 160(900): p. 87-94.
10. Padmanabhan, M., *Measurement of extensional viscosity of viscoelastic liquid foods*. *Journal of Food Engineering*, 1995. 25(3): p. 311.
11. Sliwinski, E.L., P. Kolster, and T. van Vliet, *On the relationship between large-deformation properties of wheat flour dough and baking quality*. *Journal of Cereal Science*, 2004. 39(2): p. 231-245.
12. Sliwinski, E.L., P. Kolster, A. Prins, and T. van Vliet, *On the relationship between gluten protein composition of wheat flours and large-deformation properties of their doughs*. *Journal of Cereal Science*, 2004. 39(2): p. 247-264.
13. Uthayakumaran, S., M. Newberry, N. Phan-Thien, and R. Tanner, *Small and large strain rheology of wheat gluten*. *Rheologica Acta*, 2002. 41(1): p. 162-172.
14. Tschoegl, N.W., J.A. Rinde, and T.L. Smith, *Rheological Properties of Wheat Flour Doughs I*. *J. Sci. Fd Agric*, 1970. 21: p. 65-70.
15. Tschoegl, N.W., J.A. Rinde, and T.L. Smith, *Rheological properties of wheat flour doughs II*. *Rheol. Acta*, 1970. 9: p. 223-238.
16. Dobraszczyk, B.J. and M.P. Morgenstern, *Rheology and the breadmaking process*. *Journal of Cereal Science*, 2003. 38(3): p. 229-245.
17. Kokelaar, J.J., T. van Vliet, and A. Prins, *Strain Hardening Properties and Extensibility of Flour and Gluten Doughs in Relation to Breadmaking Performance*. *Journal of Cereal Science*, 1996. 24(3): p. 199-214.
18. Sliwinski, E.L., P. Kolster, and T. van Vliet, *Large-deformation properties of wheat dough in uni- and biaxial extension. Part I. Flour dough*. *Rheologica Acta*, 2004. 43(4): p. 306-320.
19. Sliwinski, E.L., F. van der Hoef, P. Kolster, and T. van Vliet, *Large-deformation properties of wheat dough in uni- and biaxial extension. Part II. Gluten dough*. *Rheologica Acta*, 2004. 43(4): p. 321-332.
20. Huang, H.M. and J.L. Kokini, *Measurement of Biaxial Extensional Viscosity of Wheat-Flour Doughs*. *Journal of Rheology*, 1993. 37(5): p. 879-891.

21. Bagley, E.B., F.R. Dintzis, and S. Chakrabarti, *Experimental and conceptual problems in the rheological characterization of wheat flour doughs*. *Rheologica Acta*, 1998. 37(6): p. 556-565.
22. Hibberd, G.E., *Dynamic viscoelastic behaviour of wheat flour doughs. Part II effects of water content on the linear region*. *Rheol. Acta*, 1970. 9: p. 497-500.
23. Hibberd, G.E., *Dynamic viscoelastic behaviour of wheat flour doughs. Part III: The influence of starch granules*. *Rheol. Acta*, 1970. 9: p. 501-505.
24. Hibberd, G.E. and N.S. Parker, *Dynamic Viscoelastic Behavior Of Wheat-Flour Doughs.4. Nonlinear Behavior*. *Rheologica Acta*, 1975. 14(2): p. 151-157.
25. Hibberd, G.E. and W.J. Wallace, *Dynamic Viscoelastic Behaviour of Wheat Flour Doughs. Part I. Linear aspects*. *Rheol. Acta*, 1966. 5(3): p. 193-198.
26. McKinley, G.H. and T. Sridhar, *Filament-stretching rheometry of complex fluids*. *Annual Review Of Fluid Mechanics*, 2002. 34: p. 375-415.
27. Szabo, P., *Transient filament stretching rheometer.1. Force balance analysis*. *Rheologica Acta*, 1997. 36(3): p. 277-284.
28. Szabo, P. and G.H. McKinley, *Filament stretching rheometer: inertia compensation revisited*. *Rheologica Acta*, 2003. 42(3): p. 269-272.
29. Anna, S.L., G.H. McKinley, D.A. Nguyen, T. Sridhar, S.J. Muller, J. Huang, and D.F. James, *An interlaboratory comparison of measurements from filament-stretching rheometers using common test fluids*. *Journal Of Rheology*, 2001. 45(1): p. 83-114.
30. Sentmanat, M., E.B. Muliawan, and S.G. Hatzikiriakos, *Fingerprinting the processing behavior of polyethylenes from transient extensional flow and peel experiments in the melt state*. *Rheologica Acta*, 2004. 44(1): p. 1-15.
31. Sentmanat, M., B.N. Wang, and G.H. McKinley, *Measuring the transient extensional rheology of polyethylene melts using the SER universal testing platform*. *Journal Of Rheology*, 2005. 49(3): p. 585-606.
32. Sentmanat, M.L., *Miniature universal testing platform: from extensional melt rheology to solid-state deformation behavior*. *Rheologica Acta*, 2004. 43(6): p. 657-669.
33. Schulze, J.S., T.P. Lodge, C.W. Macosko, J. Hepperle, H. Munstedt, H. Bastian, D. Ferri, D.J. Groves, Y.H. Kim, M. Lyon, T. Schweizer, T. Virkler, E. Wassner, and W. Zoetelief, *A comparison of extensional viscosity measurements from various RME rheometers*. *Rheologica Acta*, 2001. 40(5): p. 457-466.
34. Li, W., B.J. Dobraszczyk, and J.D. Schofield, *Stress relaxation behavior of wheat dough, gluten, and gluten protein fractions*. *Cereal Chemistry*, 2003. 80(3): p. 333-338.
35. Phan-Thien, N., M. Safari-Ardi, and A. Morales-Patino, *Oscillatory and simple shear flows of a flour-water dough: A constitutive model*. *Rheologica Acta*, 1997. 36(1): p. 38-48.
36. Phan-Thien, N. and M. Safari-Ardi, *Linear viscoelastic properties of flour-water doughs at different water concentrations*. *Journal of Non-Newtonian Fluid Mechanics*, 1998. 74(1-3): p. 137.
37. Gabriele, D., B. de Cindio, and P. D'Antona, *A weak gel model for foods*. *Rheologica Acta*, 2001. 40(2): p. 120.
38. Bird, R.B., R.C. Armstrong, and O. Hassager, *Dynamics of polymeric liquids - Fluid Mechanics*. 2nd ed. Vol. 1. 1987, New York: Wiley.
39. Barnes, H.A., *The yield stress - a review or 'pi alpha nu tau alpha rho epsilon iota' - everything flows?* *Journal Of Non-Newtonian Fluid Mechanics*, 1999. 81(1-2): p. 133-178.
40. Boger, D.V., *The Diabolical Case of the Recurring Yield Stress*. *Applied Rheology*, 2004. 14(1): p. 40-45.
41. Hutchinson, J.W. and H. Obrecht, *Tensile Instabilities in Strain-Rate Dependent Materials*. in *Fracture*. 1977. Waterloo, Canada.
42. McKinley, G.H. and O. Hassager, *The Considered condition and rapid stretching of linear and branched polymer melts*. *Journal of Rheology*, 1999. 43(5): p. 1195-1212.
43. Letang, C., M. Piau, and C. Verdier, *Characterization of wheat flour-water doughs. Part I: Rheometry and microstructure*. *Journal Of Food Engineering*, 1999. 41(2): p. 121-132.
44. Belton, P.S., *On the elasticity of wheat gluten*. *Journal Of Cereal Science*, 1999. 29(2): p. 103-107.
45. Ewart, J.A.D., *Hypothesis for how linear glutenin holds gas in dough*. *Food Chemistry*, 1989. 32(2): p. 135-150.
46. Singh, H. and F. MacRitchie, *Application of Polymer Science to Properties of Gluten*. *Journal of Cereal Science*, 2001. 33(3): p. 231.