

A Simple, Versatile Robotic Arm for Classroom and Student Laboratory Use

By

David Lafferty

SUBMITTED TO THE DEPARTMENT OF MECHANICAL ENGINEERING IN  
PARTIAL FULFILLMENT OF THE REQUIREMENTS FOR THE DEGREE OF

BACHELOR OF SCIENCE  
AT THE  
MASSACHUSETTS INSTITUTE OF TECHNOLOGY

JUNE 2006

©2006 David Lafferty. All rights reserved.

The author hereby grants to MIT permission to reproduce  
and to distribute publicly paper and electronic  
copies of this thesis document in whole or in part  
in any medium now known or hereafter created.

**ARCHIVES**

Signature of Author: \_\_\_\_\_  
Department of Mechanical Engineering  
12 May 2006

Certified by: \_\_\_\_\_  
John J. Leonard  
Associate Professor of Mechanical and Ocean Engineering  
Thesis Supervisor

Accepted by: \_\_\_\_\_  
John H. Lienhard V  
Professor of Mechanical Engineering  
Chairman, Undergraduate Thesis Committee

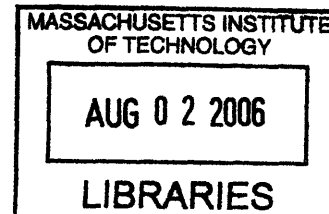

# A Simple, Versatile Robotic Arm for Classroom and Student Laboratory Use

By

David Lafferty

Submitted to the Department of Mechanical Engineering  
on May 12, 2006 in partial fulfillment of the  
requirements for the Degree of Bachelor of Science in  
Mechanical Engineering

## **Abstract**

Robotic arms are indispensable tools in both industry and education. The robotic arm currently used in the MIT class 2.12, Introduction to Robotics, is in need of revision. The arm is heavy, imprecise, bulky, and difficult to customize. The new design presented in this thesis resolves these issues while making the arm more user-friendly and inexpensive enough for classroom use. It uses Hitec HS-805BB hobby servo motors to directly drive each joint. Controlling these motors is effortless with the many commercially available servo motor drivers. Modular construction allows students to change the shape and size of the arm's workspace easily; creating and installing custom linkages is a simple task. Linkages and motor output shafts mount to a common connection shaft with one-sided cut hubs. The radial loads in these shafts are supported by maintenance-free Super Oilite bronze bearings.

This robotic arm is better suited for a classroom environment than the current one. It weighs 2.7 pounds; the old one weight 21.2 pounds. Though its workspace and recommended linkage length are about 7% smaller than those of the old design are, it is 87% more precise. It is 60% cheaper with a materials cost of \$120 for a two degree of freedom arm. The new motors have 343 oz-in of torque, which is sufficient to handle a 12 oz payload 17 inches from the joint axis or a 16 oz payload at 14 inches. Students will spend less time connecting wires and calibrating sensors. This arm should be a welcome addition to the introductory robotics classroom.

Thesis Supervisor: John Leonard

Title: Associate Professor of Mechanical and Ocean Engineering

## **Acknowledgments**

Special thanks to my family for proofreading this document in its early revisions.

# Table of Contents

<b>ABSTRACT</b> .....	<b>2</b>
<b>ACKNOWLEDGMENTS</b> .....	<b>3</b>
<b>TABLE OF CONTENTS</b> .....	<b>4</b>
<b>1. INTRODUCTION TO ROBOTIC ARMS</b> .....	<b>5</b>
<b>2. EXISTING DESIGN</b> .....	<b>7</b>
<b>3. NEW DESIGN</b> .....	<b>9</b>
3.1 ACTUATORS .....	9
3.2 POWER TRANSMISSION .....	12
3.3 LINKAGES .....	14
<b>4. RESULTS</b> .....	<b>14</b>
<b>5. DISCUSSION</b> .....	<b>18</b>
<b>6. CONCLUSIONS</b> .....	<b>20</b>
<b>REFERENCES</b> .....	<b>21</b>
<b>DRAWINGS</b> .....	<b>21</b>
ORIGINAL TWO-AXIS ARM ASSEMBLY .....	22
NEW TWO-AXIS ARM ASSEMBLY .....	23
SINGLE LINKAGE ASSEMBLY .....	24
SERVO MOUNTING ASSEMBLY.....	28
THREE-AXIS ARM PROTOTYPE ASSEMBLY .....	36

# 1. Introduction to Robotic Arms

Numerically controlled manipulators, or robotic arms, have found a role in industry for nearly fifty years. This relatively young market took its first foothold in 1961 when General Motors started using a Unimate robotic arm to stack hot pieces of die-cast metal (“Timeline of Robotics” 2006). George Devol and Joseph Engelberger, founders of Unimation, designed the Unimate to aide in automated manufacturing. Today, FANUC Robotics of Japan leads the robot manufacturing industry (Hui 2001). FANUC primarily produces robotic arms for assembly, packing, material removal, welding, and painting. The Space Station Remote Manipulator System, also known as Canadarm, is one of today’s most advanced robotic arms.

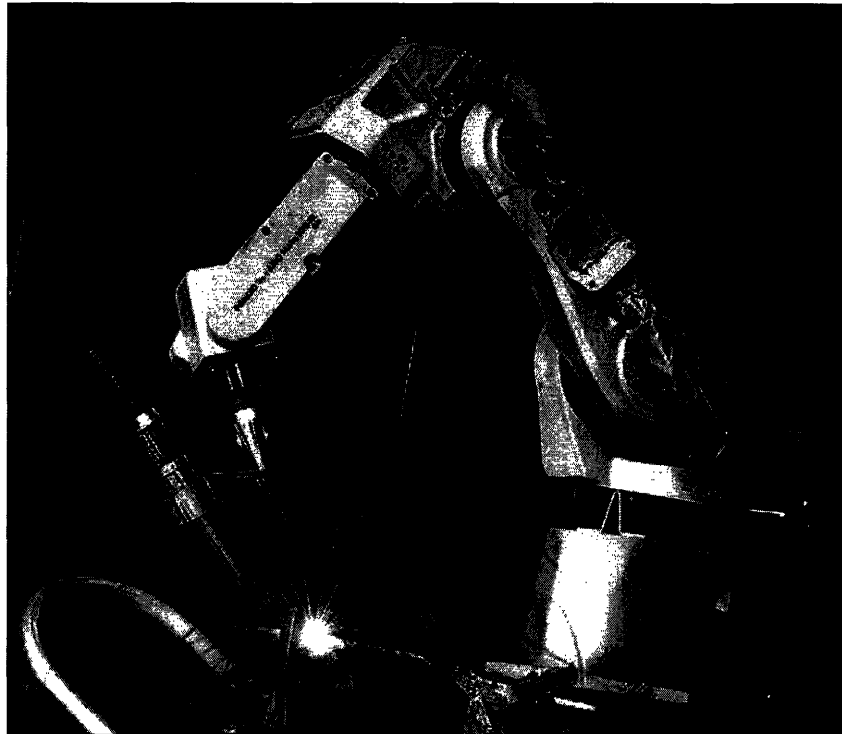

Figure 1: A FANUC ARC Mate 100iB/6S arc-welding robot with six degrees of freedom (Image source: <[http://www.fanucrobotics.com/file\\_repository/fanucmain/ARC%20Mate%20100iB%206S.pdf](http://www.fanucrobotics.com/file_repository/fanucmain/ARC%20Mate%20100iB%206S.pdf)>).

A robotic arm is a machine that positions an end effector – a gripper, spot-welder, or spray gun, for example – according to the commands it receives. These commands are given by a remote operator, a stored script, or a higher-level computer program. The set of positions an arm can reach is called its workspace. To move an end effector, the arm moves one or more joints. Rotary or revolute joints are common; these joints rotate a linkage about an axis. Some arms have linear, or sliding, joints, which tend to be more expensive. An arm has degrees of freedom equal to the number of joints that can independently change the position or orientation of the end effector. The human arm has seven degrees of freedom – three at the shoulder, one at the elbow, one at the forearm, and two at the wrist – all of which are rotary. At least six degrees of freedom are necessary to locate an object at an arbitrary position and orientation (Asada 2005, 2).

In education, numerically controlled manipulators provide a practical and appealing introduction to robotics. In classrooms, robotic arms can be used to aid in teaching computer-machine interaction, control algorithms, Jacobian matrices, and feedback loops. Students can quickly gain satisfaction and understanding when a mechanical arm moves in response to their movement of a potentiometer or execution of a line of code. To be practical for classroom use, a robotic arm should be affordable, reliable, and bench-top sized. To be effective in the classroom, a robotic arm should also be adaptable and capable of several levels of performance; students should be able to operate it without much knowledge of the system, and they should be able to develop mastery of the system to use it for a variety of tasks.

The MIT class 2.12, Introduction to Robotics, targets mechanical engineering students with minimal electronics and software experience. Robotic arms are an integral

part of the laboratory portion of the class. The arms used in the 2005 fall semester, while fairly capable, were not ideal for the demands of the class. They were too large and massive to be easily mounted on the mobile robot bases used in the class. Students also gave negative feedback about the precision of the arms' movements. Presented here is a redesign of that arm focused on reducing weight and footprint, and increasing precision and ease of use.

## **2. Existing Design**

The arm currently used in 2.12 laboratory sessions consists of a base and two links mechanized by two revolute joints. Motors mounted to the base drive each joint. There is a gear reduction from the motors to the linkages. The second link is driven indirectly via a rubber timing belt and pulleys. See page 22 for a drawing of the assembly. I estimate that the total cost of materials is around \$300.

Many parts of the arm are built with much more material than necessary. The linkages are machined from  $\frac{3}{4}$ " by 2" aluminum bar stock and weigh approximately 1.2 lb each. The base is a 6.5 lb plate of  $\frac{1}{2}$ " aluminum. For the forces on the arm, quarter inch thick aluminum bar and plate would be excessive. The entire assembly weighs approximately 21 pounds (note: Solidworks calculated this figure by summing the products of the volume and density for each component in the assembly). With the current motors and gear ratio, the arm can deliver 6 lb of force 18 inches from the axis of rotation, or approximately 2000 oz-in of torque.

Some parts of the current arm cause for considerable imprecision. The largest error in position control comes from the rubber belt used to drive the second joint. Small

deformations in the belt result in considerable deflections in the angle of the second link. The link can move roughly 15 degrees without the motor shaft budging. The belt, though it has teeth meshing with the pulleys, is prone to slipping. Another source of error in controlling the position of this arm is backlash between the potentiometers that sense position and the linkages. Two gear transitions between the potentiometers and the drive shaft cause the backlash of the first link. The backlash of the second link comes from two gear transitions as well as the belt and pulleys.

The arm features some components that make adjustment easy, but ultimately is difficult to adapt to new tasks. One common task performed on a robotic arm is calibrating the 0- or 90-degree position of each of its joints. The positions of the potentiometer and links can be decoupled by loosening one setscrew on the potentiometer shaft, allowing for easy calibration. On the other hand, mounting the arm on a mobile robot – one of the laboratory tasks in 2.12 – is a challenge due to the arm's weight and bulk. Likewise, modifying the lengths of the linkages for different tasks requires tremendous effort. The arms are mounted on keyed shafts with close tolerances and held from lateral movement by e-clips. The end of the first link requires several steps of precision machining to mount the second joint's bearing assembly.

The electrical interface of the arm could use some improvement as well. Each joint has a potentiometer with wire leads for position output. Each motor is driven by an electronic speed control requiring a separate power supply. The speed controls can be driven by a microcontroller or servo motor driver. The \$300 cost of the speed controls is not included in the materials cost estimate above.



The arm is most often used for functions that require precision positioning rather than large amounts of torque. In most laboratory sections, the arm is used without any end effector or payload. In these classes, students learn to control the angles of the joints and the position of the end of the arm. For the final project, students mount the arms to mobile robot bases and use them to perform some simulated task. In fall semester 2005, Barbie-style dolls were retrieved from 6-inch tall houses on a 100 square foot playing field.

### **3. New Design**

In redesigning the 2.12 arm, it was important to consider the qualities that make a good robotic arm for classroom use. While maintaining similar workspace, manufacturing cost, materials, and functionality, the new design strives to eliminate the properties of the existing arm that make working with it difficult. This design focuses on reducing weight and footprint, and increasing precision and ease of use.

The design process for electro-mechanical machines like this begins with their general form and function. In this situation, the original design dictates that this machine will have two motorized linkages on revolute joints. Beyond that, component selection and design become an optimization exercise.

#### **3.1 Actuators**

In a robotic arm, a large factor in the appearance of the final product is the actuator selection. The body of the motor and the output shaft determine how the motor



Figure 2: This robot arm made by Lynxmotion was designed around the six hobby servos that actuate it (Image source: <<http://www.active-robots.com/products/robots/robotic-arms.shtml>>).

will connect to the rest of the machine. The arm pictured above uses hobby servo motors, which are popular due to their low cost and high strength-to-weight ratio.

The first step in selecting motors is choosing the type of motor. Since batteries will power these motors in the laboratory, low voltage direct current is requisite. Servo motors with integrated absolute position sensing will eliminate the extra hardware associated with external encoders or position sensors. Finally, the desired speed of the motor is very low – about 12 rpm. Such a low speed can only be accomplished through a gearbox. A reduction with a worm gear would significantly reduce the speed, but worm gears cannot be back-driven. Gearboxes integrated into motors tend to be much more efficient than external gearboxes. Therefore, geared DC servo motors are most practical for this task.

The next step is determining the torque or power for the application. This torque is given by

$$\tau = \sum F \cdot r = \sum mgr \sin \theta , \quad (1)$$

where force,  $F$ , equal mass,  $m$ , times gravity,  $g$ . The distance from the joint to the mass is  $r$ . Torque,  $\tau$ , is listed as a sum of torques representing different components of the arm – each with their own mass and distance to the joint.  $\theta$  is the angle between the direction of gravity and the direction of linkage. The maximum torque on a joint will occur when the end effector is extended as far as possible from the joint and the axis of the joint is perpendicular to gravity, where  $\sin \theta$  equals 1. Under normal operation, a joint will not be subject to this torque because this position is at the edge of the workspace.

For this arm, the length of each arm segment is taken to be 9 inches, like the original arm. A typical Barbie doll and student-made gripper weigh about 10 ounces, but this calculation will use 1 lb to be conservative. For a 1 lb mass at the end effector, a 1 lb first link, and a 0.3 lb second link, the maximum torque on the first joint is 420 oz-in:

$$\tau_{\max} = [(1lb \ 4.5in) + (0.3lb \ 13.5in) + (1lb \ 18in)] = 420oz \cdot in . \quad (2)$$

The next step in specifying a motor is the power requirement. The power required rotate at an angular velocity  $\omega$  is

$$P = \tau \cdot \omega . \quad (3)$$

It is reasonable to expect this arm to move its end effector at 0.5 m/s or 20 in/s. At a distance of 18 inches, this translates to 63 degrees per second or 10.4 rpm. The maximum power is then

$$P_{\max} = \tau_{\max} \cdot \omega = 420oz \cdot in \ 63 \frac{\text{deg}}{s} = 3.3W . \quad (4)$$

The motor selected, the HS-805BB by Hitec, approximately meets these requirements. It is only specified at delivering 343 oz-in of torque given a 6.0 V input. However, it does provide about 10W of mechanical power. This motor has the highest torque output of any readily available inexpensive hobby servo motor. At \$40 each, this motor is more appealing than the \$150 motors that actually meet the torque and power specifications. It also weighs much less than the industrial alternatives.

The design constraints must be revised to compensate for the motor's torque specification. Reducing the length of the link arms and the mass of the end effector will reduce the torque requirement. To avoid shrinking the workspace much, the link lengths were reduced to 8.5 inches each. At 17 inches, an end effector mass of 12 ounces will not exceed the 343 oz-in torque limit. Therefore, end effectors and their payloads must be limited to a maximum 12 ounces. This limit applies only when the first joint axis is perpendicular to the direction of gravity and the end effector is 17 inches from that axis. At 14 inches, the weight limit goes up to a full pound.

### ***3.2 Power Transmission***

Efficiently transferring power from the motors to their respective linkages is a key part of the design. A single stage gear reduction could increase torque to the desired amount. However, the range of motion of the servos is limited to 180 degrees, and a gear reduction would further limit that range. In general, each stage of a gear reduction is about 90% efficient. Driving joints directly from the servos requires fewer components than a geared drive train and does not have any power loss. Direct drive is lighter and less

expensive because it has fewer parts, making it the more sensible choice for this application. A detailed drawing of the power transmission subsystem is on page 28.

Rather than support the load with the output shaft of the motor, a sleeve bearing supports the drive shaft. Needle or ball bearings would be incrementally more efficient, but at a significantly greater price. To keep the overall size of the servo mounting assembly down, the length of the bearing – and hence the thickness of the bearing plate – were chosen to be 1/4". This limited the shaft size choices to 1/4" and 3/8". The selected shaft diameter is 3/8", which requires less clamping force and allows a hollow shaft to be used, if desired. For minimum maintenance and long bearing life, the bearings are SAE 863 bronze, or Super Oilite, and the shafts are tool steel.

The bearing must be precisely aligned with the output shaft of the motor for smooth operation. Therefore, the servo mounting plate and servo mounting bracket, shown on pages 30 and 33 respectively, must be precisely machined. Multi-purpose 6061 aluminum should be used for these parts due to its strength and ease of machining. The spacers between the servo mounting plate and bracket are less critical. These can be made of wood, plastic, or aluminum, as long as the lengths are correct.

A custom part connects the servo to the drive shaft. The servos come with plastic horns that fit on their splined output shafts. The servo shaft clamp, as shown on page 32, bolts to the servo horn. It clamps around the shaft without any modification to the shaft, as a pin or setscrew would require. A similar component connects the other end of the drive shaft to a linkage. These shaft clamps are one-sided cut hubs that allow the linkage to be positioned at any angle with respect to the motor's drive shaft. Due to the high stresses on

these parts and the precision machining required, 6061 aluminum is a good choice for materials.

### **3.3 Linkages**

The linkages are intended to be low-cost, easily modified or reproduced, simple components. They are currently made of 1/8" by 1 1/2" aluminum bar. Each end of the linkage has the same high-tolerance hole pattern. This one-inch square hole pattern should be compatible with readily available base plates and end effectors. The linkages can be made of practically any building material – ABS, Delrin, wood, fiberglass, carbon fiber, etc. – as long as it can support the loads.

## **4. Results**

The complete two-linkage assembly weighs 2.7 lb including fasteners. The footprint is 1 1/2" by 2" if bolted or clamped to larger platform. For freestanding use, the arm must be attached to a platform that is large enough that the center of mass of the arm does not pass its boundaries. The complete bill of materials for five two-axis arms is shown in Table 1 below.

Table 1: Bill of materials for five two-axis arm assemblies.

Part Name	Description	Dimensions	Mass (g)	Qty	Price Ea.	Ext. Price	Material	Vendor	Vendor PN	Notes
Servo Motor	Hitech HS-805BB Mega Servo		159	10	\$38.00	\$380.00	Plastic	Tower Hobbies	LM2356	
Servo screw	Connects servo to servo bracket	8-32 x 1/2"	2	40	\$0.13	\$5.05	Stainless steel	Mcmaster	92196A194	Packs of 100
Servo horn screw	Connects servo horn to servo		1	10	\$0.00	\$0.00	Steel	Tower Hobbies		Included with servo
Servo horn	Circular servo horn		5	10	\$0.00	\$0.00	Plastic	Tower Hobbies		Included with servo
Servo bracket	Connects servo to servo spacer	1 1/2" x 3/8" x .729"	17	20	\$0.80	\$16.08	Aluminum 6061	Mcmaster	8975K413	36" length
Servo bracket screw	Cap head, hex socket	8-32 x 2 1/4"	3	40	\$0.31	\$12.46	Stainless steel	Mcmaster	92196A206	Packs of 25
Servo spacer	Separates servo from servo plate	1 1/2" x 3/16" x 1.65"	32	20	\$1.05	\$21.09	Aluminum 6061	Mcmaster	8975K38	6' length
Servo plate	Connects servo assembly to linkage	1 1/2" x 1/4" x 4.041"	63	10	\$1.97	\$19.66	Aluminum 6061	Mcmaster	8975K25	6' length
Bearing	Flange bearing	3/8"x1/4"	5	10	\$0.49	\$4.90	SAE 863 Bronze	Mcmaster	2938T6	Each
Linkage	Primary arm linkage	1 1/2" x 1/8" x 10"	80	10	\$2.12	\$21.24	Aluminum 6061	Mcmaster	8975K34	6' length
Servo shaft clamp	Connects servo horn to shaft	Φ1.65" x 1/2"	15	10	\$3.81	\$38.09	Aluminum 6061	Mcmaster	8974K69	36" length
Shaft	Coupling shaft	Φ3/8" x 1.68"	23	10	\$0.54	\$5.43	01 Tool Steel	Mcmaster	8893K42	36" length
Shaft clamp	Connects linkage to shaft	1 1/2" x 1/2" x 1 1/2"	44	10	\$1.95	\$19.51	Aluminum 6061	Mcmaster	8975K423	36" length
Shaft clamp screw	Cap head, hex socket	10-24 x 1 1/4"	6	10	\$1.38	\$13.78	Stainless steel	Mcmaster	91251A249	Packs of 100
Servo shaft clamp screw	Cap head, hex socket	10-24 x 1"	6	10	\$1.00	\$10.00	Stainless steel	Mcmaster	96006A652	Packs of 50
Clamp screw	Button head, hex socket	8-32 x 1/2"	2	80	\$0.08	\$6.71	Stainless steel	Mcmaster	92949A194	Packs of 100
Linkage screw	Button head, hex socket	8-32 x 5/16"	2	40	\$0.16	\$6.53	Stainless steel	Mcmaster	92949A191	Packs of 100
Two Axis Arm	Complete Assembly		1098	5	\$116.11	\$580.53				

Each joint supplies 343 oz-in of torque. The maximum payload as a function of the linkage length is shown in Figure 3. This maximum load occurs when the arm is fully extended and completely horizontal. The graph assumes both links are the same length. If the first link is shorter than the second link, the curve shifts up. Likewise, if the first link is longer than the second link, the curve shifts down.

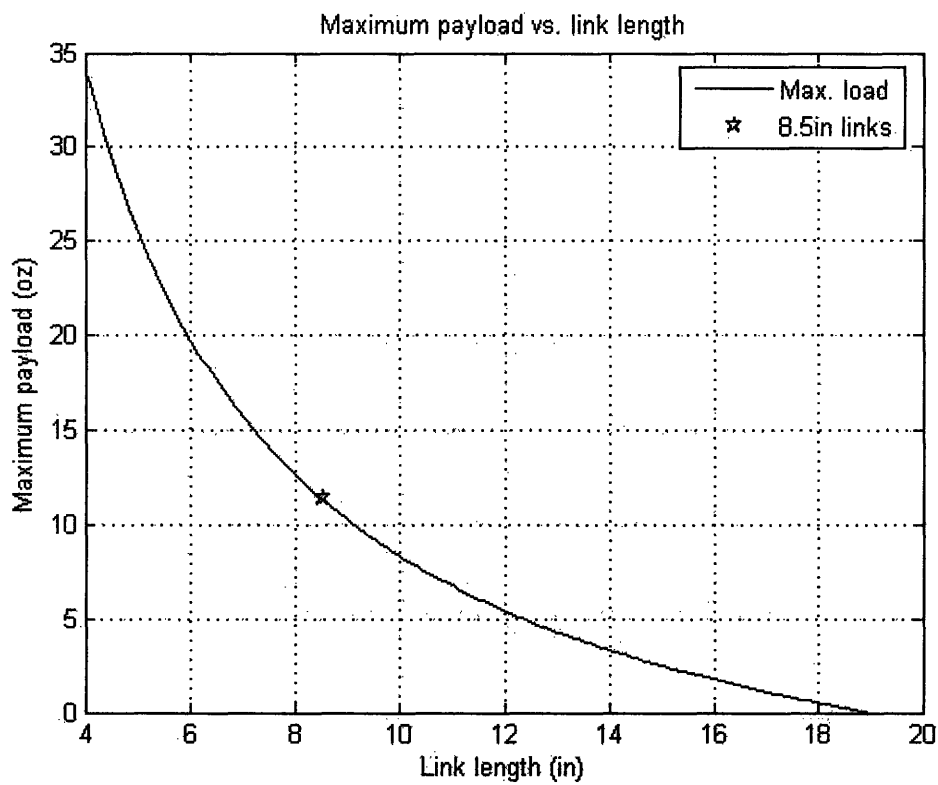

Figure 3: Plot of the maximum combined weight of the end effector and the payload. The star marks the current design selection of 8.5 inches and 12 ounces.

With no load, the joints can move up to 430 degrees per second; there is no minimum angular velocity. The joint angles are accurate to  $\pm 1$  degree. The joints have a



motion range of 180 degrees. Potential workspaces for this range of motion are shown in Figure 4.

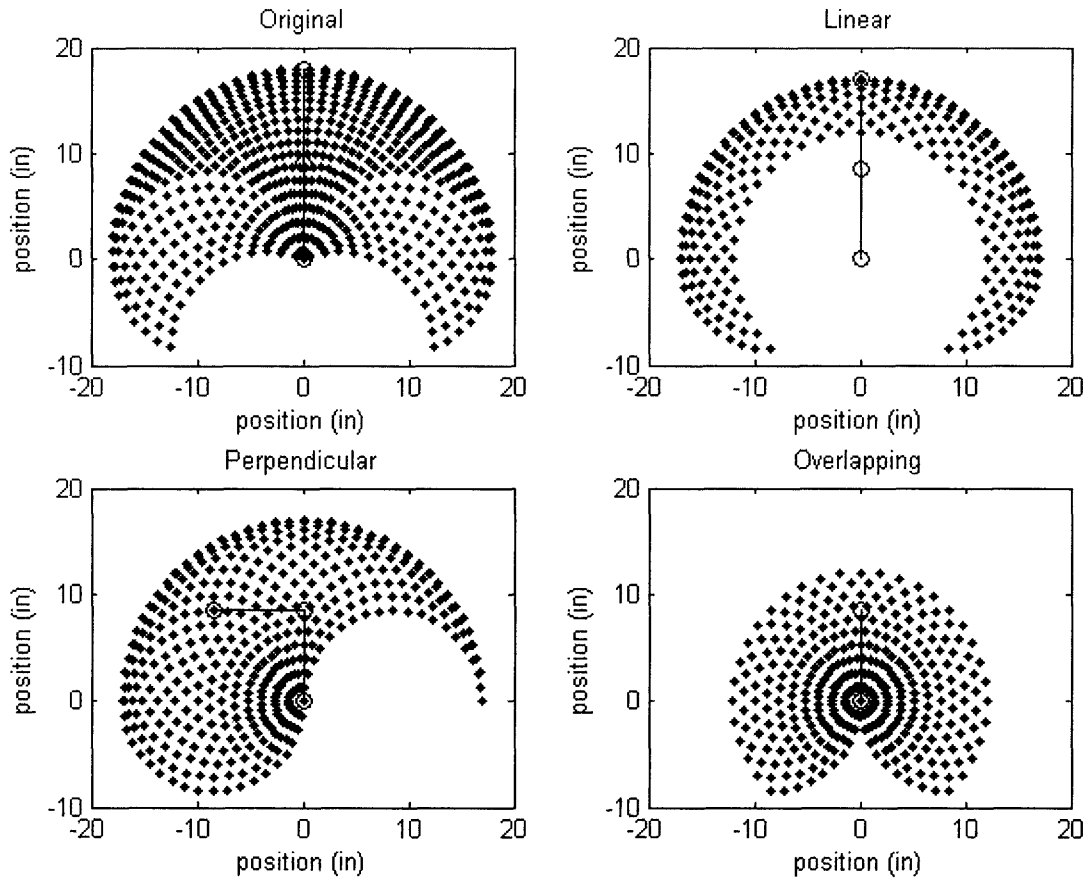

Figure 4: Plots of the workspace for various configurations. The first plot shows the original arm with 9 in links. Each remaining plot is a simulation of a 2-link arm with 8.5 in linkages that can rotate 180 degrees each. The angle of the center position of the second link with respect to the first is 0 degrees (linear), 90 degrees (perpendicular), and 180 degrees (overlapping). Lines with circles on the ends represent the links in their center positions. The areas of each workspace are approximately  $630 \text{ in}^2$ ,  $317 \text{ in}^2$ ,  $585 \text{ in}^2$ , and  $398 \text{ in}^2$  respectively.

The servo manufacturer recommends a supply voltage from 4.8V to 6.0V. The servos require a 5V square wave signal every  $1500 \mu\text{s}$ . The angle of the motor is

proportional to the length of time of the square wave. With a 6.3V supply, the stall current is 3.9 amps.

## 5. Discussion

The true assessment of this robotic arm's performance will come when it is tested in a classroom environment. Until then, its measurable properties must determine its potential for success.

The new design compares favorably to the old arm in mass, price, and size. At 2.7 lb, this arm is less of a liability than the old 21.2 lb version. The total cost of materials per arm is around \$120, less than half of the estimated cost for the original arm. The old arm has a 9" by 15" by ½" base plate. When clamped or bolted to a surface, the footprint of the new arm is only 1.5" by 2". For freestanding use, a 6 inch by 11 inch by ¼" aluminum base plate is recommended. This plate would add an extra 1.6 lb to the mass and \$14 to the cost per arm. In fact, the linkages from the old arm are heavy enough and large enough to be stable base plates.

The precision and reliability of the new design more than compensate the decrease in torque. The new arm's one degree precision on both joints offers better end point position control than the old arm. Without any gears or pulleys to slip, these arms are maintenance-free. The new arm has slightly less reach; and as previously acknowledged, the greatest drawback of the new arm is its reduced torque. The 343 oz-in torque limit means that this arm will not be lifting large pieces of die-cast metal. However, it can still lift a full can of diet soda or half a loaf of bread without difficulty.

Operating this arm is both easier and more precise than the old arm. To control the arm manually, it can be connected directly to a remote control car or plane receiver. The

arm can be used immediately once the motors and a battery are plugged into the receiver. There are many commercially available servo motor drivers for controlling the robotic arm from a computer or microprocessor. One or two lines of code can then set the angle of each joint. Speed and endpoint position control require just a few more lines of code.

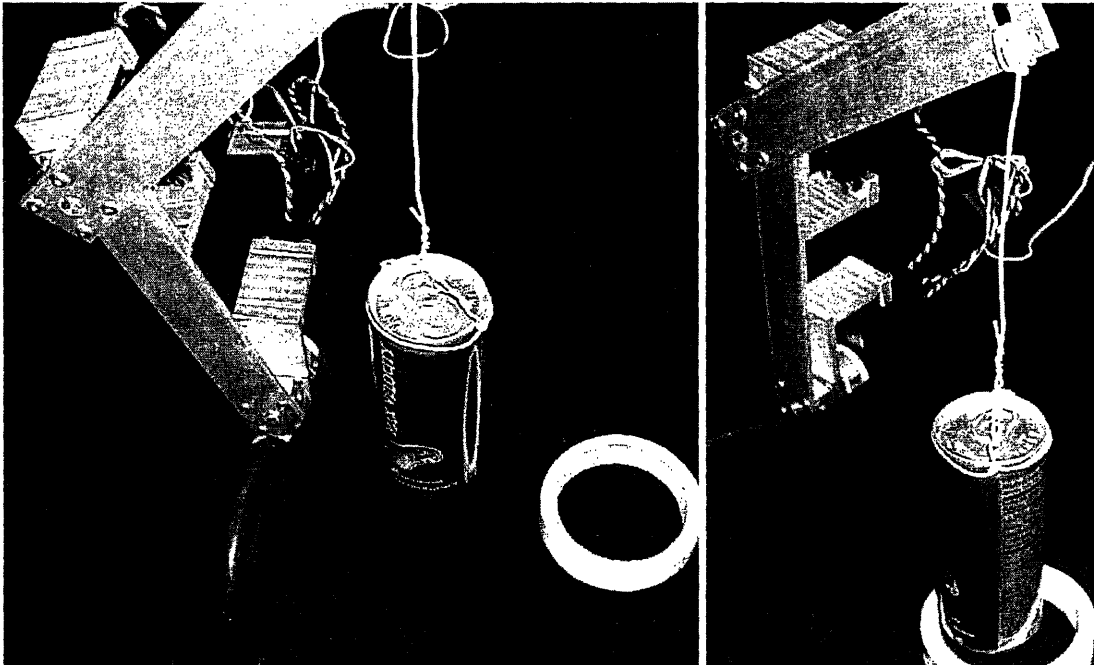

Figure 5: One of the arm's first tasks was a game of put-the-energy-drink-in-the-hoop. The arm's movements were predictable and precise. The motors handled the 9 ounce (weight) can with ease.

The overall mechanical design is accessible to students. There are no black boxes hiding the mechanics of the arm from students. To change the angle of a linkage with respect to the motor shaft, one hex key is required to loosen and tighten the shaft clamp. Another hex key removes the linkage from the shaft clamp and servo plate. The entire arm can be fully dismantled or assembled with three hex keys and a Phillips head screwdriver (to remove the servo horn screw). Students should feel free to make their own custom

linkages to suit new projects. They can machine new linkages with a band saw and drill press or print them with a water jet or laser cutter. The entire process of designing, fabricating, and installing new linkages should take the typical 2.12 student less than one hour.

## **6. Conclusions**

The design presented here for a robotic arm to be used in the MIT class 2.12, Introduction to Robotics, varies in several significant ways from the arm currently used in the class. The new arm is 87% lighter (80% with base plate) and approximately 60% less expensive (55% with base plate) than the current model. The angular precision of the second joint is approximately 87% better. However, it has 83% less torque, 6% less reach, and 7% smaller workspace. Despite the decrease in torque, it can still lift a 12 ounce payload 17 inches from the first joint.

The new arm is designed to be constructed and controlled intuitively. Connecting to the arm and commanding its motions have been reduced to minor tasks. Students can easily configure the size and shape of the arm's workspace depending on the task. Its modular construction expands the horizons of the arm's usefulness. For example, page 36 shows a three degree of freedom arm with a hemispherical workspace.

Though this arm design is less powerful than the old 21-pounder, it is well suited for a classroom setting. Its straightforward design and simple interfaces make it accessible to entry-level robotics students. Its precise movement and ease of customization lend it to a variety of uses.

## References

Asada, H. Harry. Introduction to Robotics. Cambridge, MA: Massachusetts Institute of Technology, 2005.

Hui, Raymond. "Industrial Manipulators." TrueForce. 29 Jul 2001. 6 May 2006  
<[http://trueforce.com/Industrial\\_Manipulators\\_&\\_Automation/industrial\\_manipulators.htm](http://trueforce.com/Industrial_Manipulators_&_Automation/industrial_manipulators.htm)>.

"Timeline of Robotics." The History of Computing Project. 26 Feb 2006. The History of Computing Foundation. 6 May 2006  
<<http://www.thocp.net/reference/robotics/robotics2.htm>>.

## Drawings

The following drawings are presented for reference. Do not scale the drawings.

The correct size of the border on each drawing is 6 inches by 8.5 inches. Robotic arms constructed from these drawings may be used for personal or education use only.

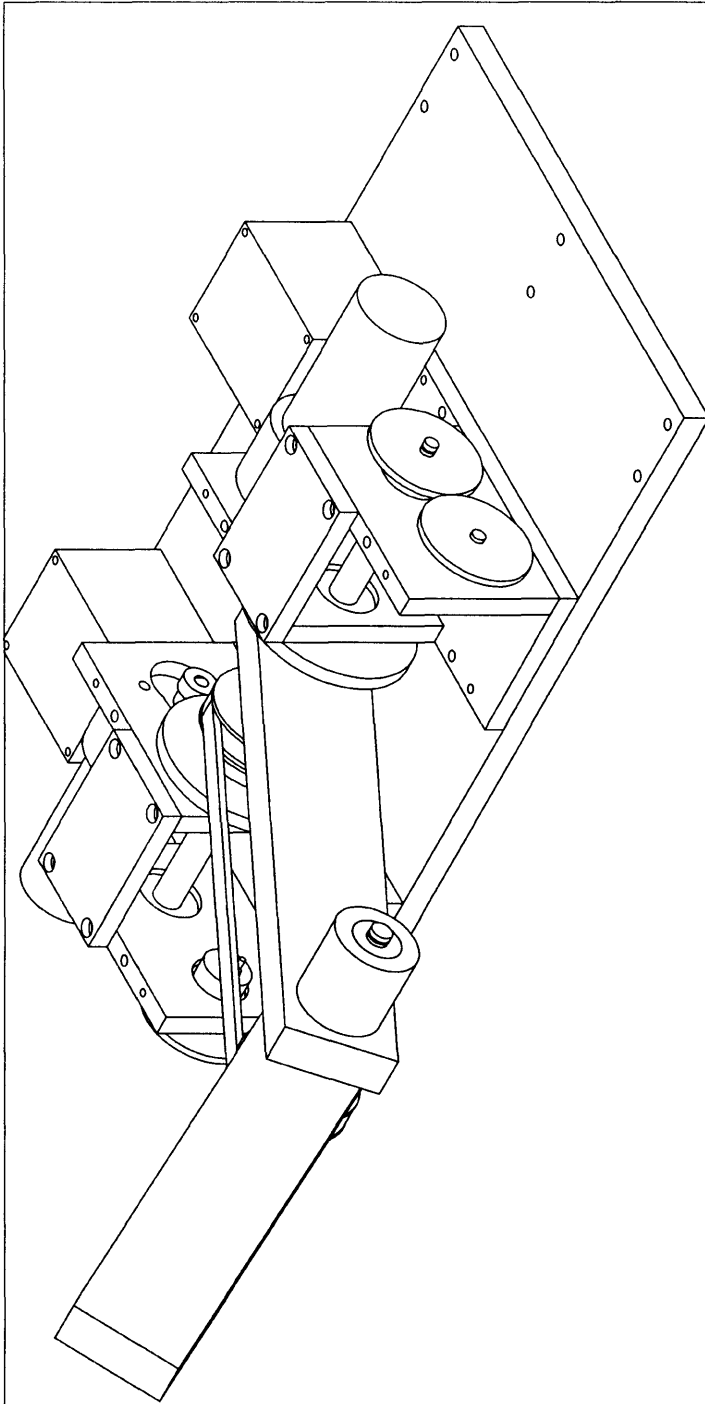

**Original Two-Axis Arm Assembly**

UNLESS OTHERWISE SPECIFIED:		NAME	DATE
DIMENSIONS ARE IN INCHES		DRAWN	
TOLERANCES:		CHECKED	
FRACTIONAL ±0.01		ENG APPR.	
ANGULAR: MACH ±		MFG APPR.	
BEND ±		Q.A.	
TWO PLACE DECIMAL ±0.01		COMMENTS:	
THREE PLACE DECIMAL ±0.005			
INTERPRET GEOMETRIC TOLERANCING PER:			
MATERIAL			
FINISH			
DO NOT SCALE DRAWING			

TITLE:  
**OriginalTwoAxisAssy**

SIZE DWG. NO. REV  
**A**

SCALE: 1:3 WEIGHT: 21.218 lb SHEET 1 OF 1

**PROPRIETARY AND CONFIDENTIAL**  
THE INFORMATION CONTAINED IN THIS DRAWING IS THE SOLE PROPERTY OF DAVID LAFFERTY. ANY REPRODUCTION IN PART OR AS A WHOLE WITHOUT THE WRITTEN PERMISSION OF DAVID LAFFERTY IS PROHIBITED.

ITEM NO.	PART NUMBER	DESCRIPTION	QTY.
1	OneLink	Single Linkage Assy	2
2	RightAngleLink	Right Angle Linkage	1
3	ServoMountAssem	Servo Mounting Assembly	2
4	screwbutton8-32x.3125	Button Screw, 8-32, 3/16", Hex Socket	8

EXPLODED VIEW

ASSEMBLED VIEW

UNLESS OTHERWISE SPECIFIED: DIMENSIONS ARE IN INCHES TOLERANCES: FRACTIONAL: ±0.01 ANGULAR: MACH ± BEND ± TWO PLACE DECIMAL ±0.01 THREE PLACE DECIMAL ±0.005	DRAWN	NAME	DATE	TITLE:
INTERPRET GEOMETRIC TOLERANCING PER:	CHECKED	DL	4/30/2006	<b>Two Axis Arm Assy</b>
MATERIAL	ENG APPR.			
FINISH	MFG APPR.			SIZE <b>A</b> DWG. NO. <b>twoaxisarm</b> REV
DO NOT SCALE DRAWING				SCALE: 1:4 WEIGHT: 2.68 lb SHEET 1 OF 1

**PROPRIETARY AND CONFIDENTIAL**  
 THE INFORMATION CONTAINED IN THIS DRAWING IS THE SOLE PROPERTY OF DAVID LAFFERTY. ANY REPRODUCTION IN PART OR AS A WHOLE WITHOUT THE WRITTEN PERMISSION OF DAVID LAFFERTY IS PROHIBITED.

**New Two-Axis Arm Assembly**

ITEM NO.	PART NUMBER	DESCRIPTION	QTY.
1	Linkage	Primary larm linkage	1
2	shaftclamp	Shaft clamp	1
3	screwbutton8-32x.5	Button Screw, 8-32, 1/2", Hex Socket	4
4	screwcap10-24x1.25	Cap Screw, 10-24, 1.25", Hex Socket	1

EXPLODED VIEW

ASSEMBLED VIEW

<p>UNLESS OTHERWISE SPECIFIED:</p> <p>DIMENSIONS ARE IN INCHES</p> <p>TOLERANCES:</p> <p>FRACTIONAL ±0.01</p> <p>ANGULAR: MACH ± BEND ±</p> <p>TWO PLACE DECIMAL ±0.01</p> <p>THREE PLACE DECIMAL ±0.005</p>	<p>INTERPRET GEOMETRIC TOLERANCING PER:</p> <p>MATERIAL</p> <p>FINISH</p>	<p>PROPRIETARY AND CONFIDENTIAL</p> <p>THE INFORMATION CONTAINED IN THIS DRAWING IS THE SOLE PROPERTY OF DAVID LAFFERTY. ANY REPRODUCTION IN PART OR AS A WHOLE WITHOUT THE WRITTEN PERMISSION OF DAVID LAFFERTY IS PROHIBITED.</p>	<p>COMMENTS:</p>	<p>NAME DL</p> <p>DATE 4/30/2006</p>
<p>TITLE: Single Linkage Assy</p>				
<p>SIZE DWG. NO. <b>A</b> onelink</p>			<p>SCALE: 1:3 WEIGHT: 0.30 lb SHEET 1 OF 1</p>	

**Single Linkage Assembly**



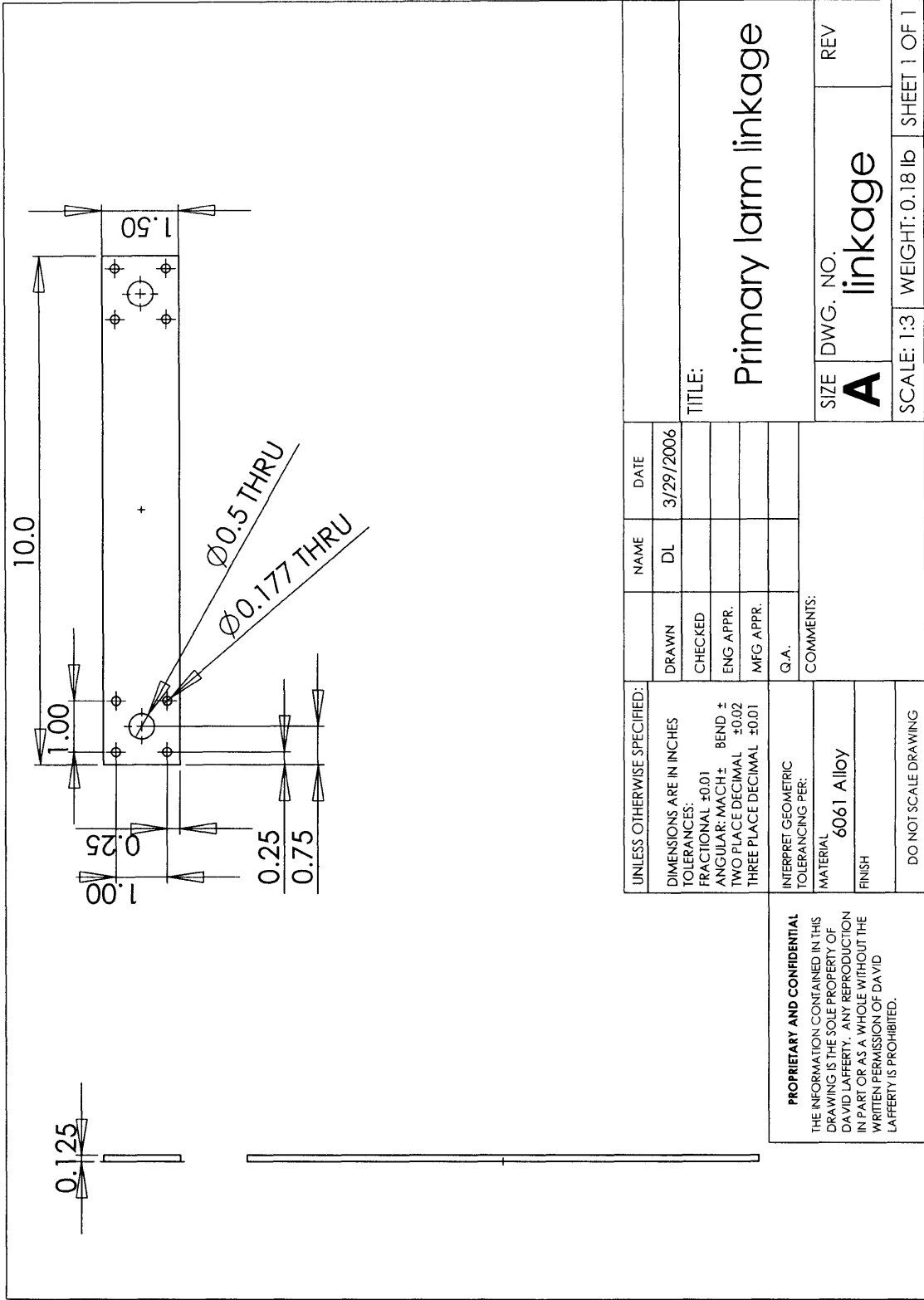

**Primary Iarm linkage**

SIZE **A** DWG. NO. **linkage** REV

SCALE: 1:3 WEIGHT: 0.18 lb SHEET 1 OF 1

UNLESS OTHERWISE SPECIFIED:	DRAWN	NAME	DATE
DIMENSIONS ARE IN INCHES	DL	DL	3/29/2006
TOLERANCES:	CHECKED		
FRACTIONAL ±0.01	ENG. APPR.		
ANGULAR: MACH ±	MFG APPR.		
BEND ±	G.A.		
TWO PLACE DECIMAL ±0.02	COMMENTS:		
THREE PLACE DECIMAL ±0.01			
INTERPRET GEOMETRIC TOLERANCING PER:			
MATERIAL:			
6061 Alloy			
FINISH:			
DO NOT SCALE DRAWING			

**PROPRIETARY AND CONFIDENTIAL**  
 THE INFORMATION CONTAINED IN THIS DRAWING IS THE SOLE PROPERTY OF DAVID LAFFERTY. ANY REPRODUCTION IN PART OR AS A WHOLE WITHOUT THE WRITTEN PERMISSION OF DAVID LAFFERTY IS PROHIBITED.

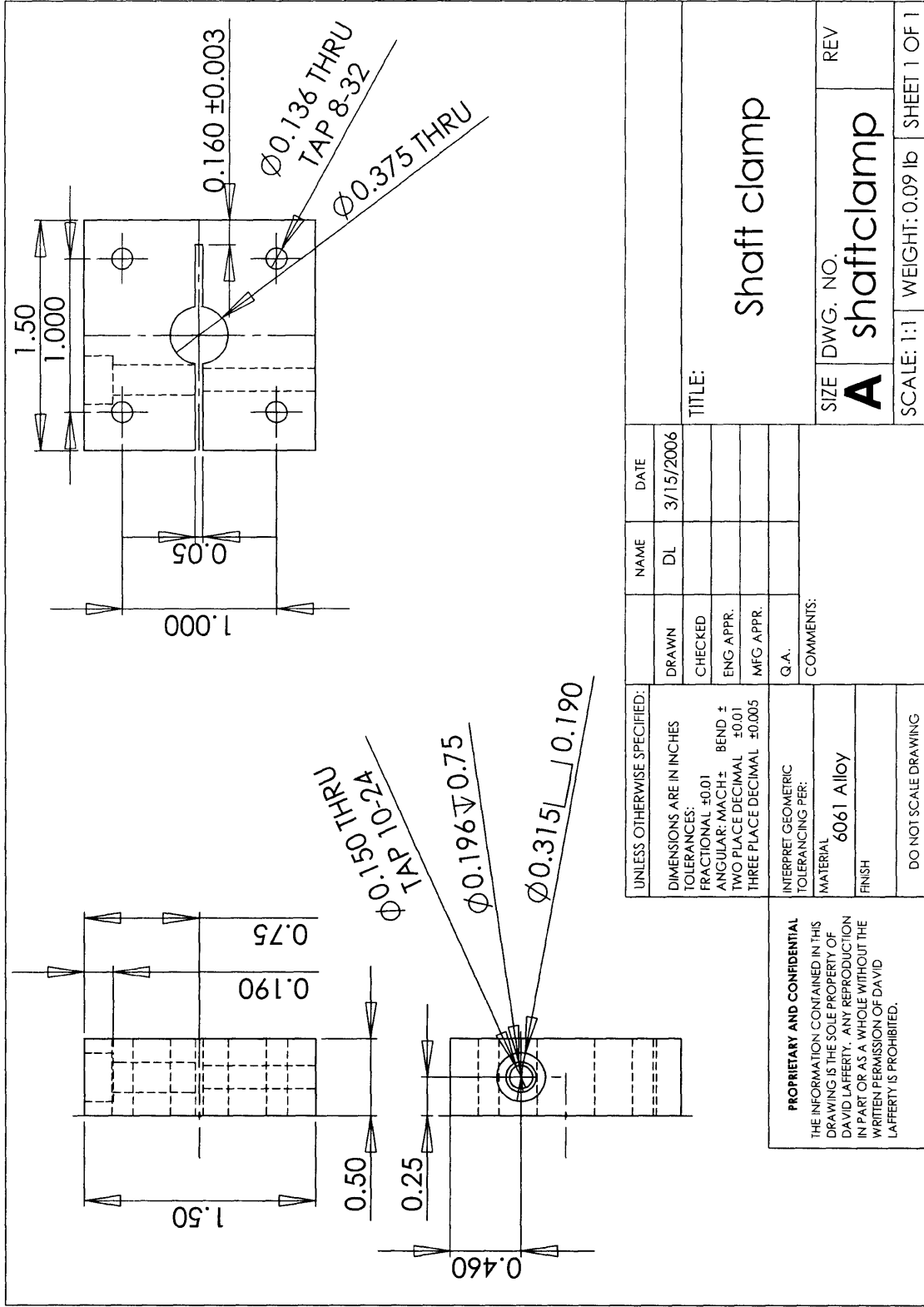

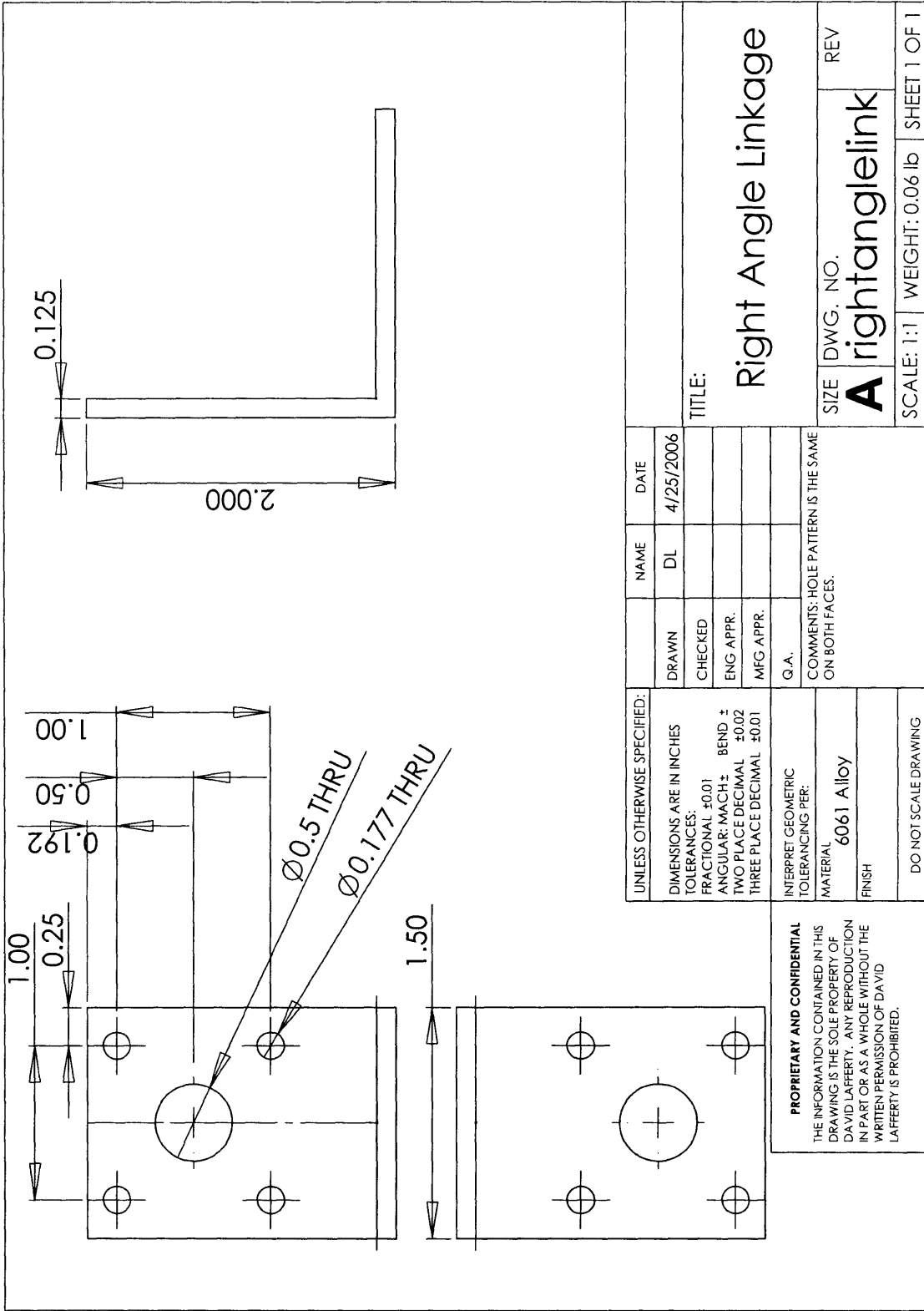

# Servo Mounting Assembly

ITEM NO.	PART NUMBER	DESCRIPTION	Default/QTY.
1	HS805BB	Mega Quarter Scale Servo Motor	1
2	bearingflange.375	Flange Bearing, 3/8", 1/4"	1
3	servoplate	Servo mount plate	1
4	servohorn	Servo horn	1
5	servoshaftclamp	Servo shaft clamp	1
6	servobrace	Servo mounting bracket	2
7	servospacer	Servo mount spacer	2
8	screwcap10-24x1	Cap Screw, 10-24, 1", Hex Socket	1
9	screwbutton8-32x.5	Button Screw, 8-32, 1/2", Hex Socket	4
10	screwcap8-32x.5	Cap Screw, 8-32, 1/2", Hex Socket	4
11	screwcap8-32x2.25	Cap Screw, 8-32, 2.25", Hex Socket	4
12	Shaft	Shaft, 3/8"	1

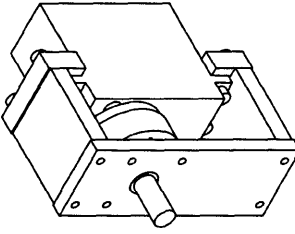

<b>ASSEMBLED VIEW</b>			
			
<p><b>UNLESS OTHERWISE SPECIFIED:</b></p> <p>DIMENSIONS ARE IN INCHES</p> <p>TOLERANCES:</p> <p>FRACTIONAL ±0.01</p> <p>ANGULAR: MACH ± BEND ±</p> <p>TWO PLACE DECIMAL ±0.01</p> <p>THREE PLACE DECIMAL ±0.005</p>		<p>NAME DL</p> <p>DATE 4/30/2006</p>	
<p>INTERPRET GEOMETRIC TOLERANCING PER:</p> <p>MATERIAL</p> <p>FINISH</p> <p>DO NOT SCALE DRAWING</p>		<p>DRAWN</p> <p>CHECKED</p> <p>ENG APPR.</p> <p>MFG APPR.</p> <p>G.A.</p> <p>COMMENTS:</p>	
<p><b>PROPRIETARY AND CONFIDENTIAL</b></p> <p>THE INFORMATION CONTAINED IN THIS DRAWING IS THE SOLE PROPERTY OF DAVID LAFFERTY. ANY REPRODUCTION IN PART OR AS A WHOLE WITHOUT THE WRITTEN PERMISSION OF DAVID LAFFERTY IS PROHIBITED.</p>			
<p>TITLE: Servo Mounting Assembly</p>			
<p>SIZE DWG. NO.</p> <p><b>A</b> servomount</p>		<p>REV</p>	
<p>SCALE: 1:3</p>		<p>WEIGHT: 0.99 lb</p>	<p>SHEET 1 OF 2</p>

EXPLODED VIEW

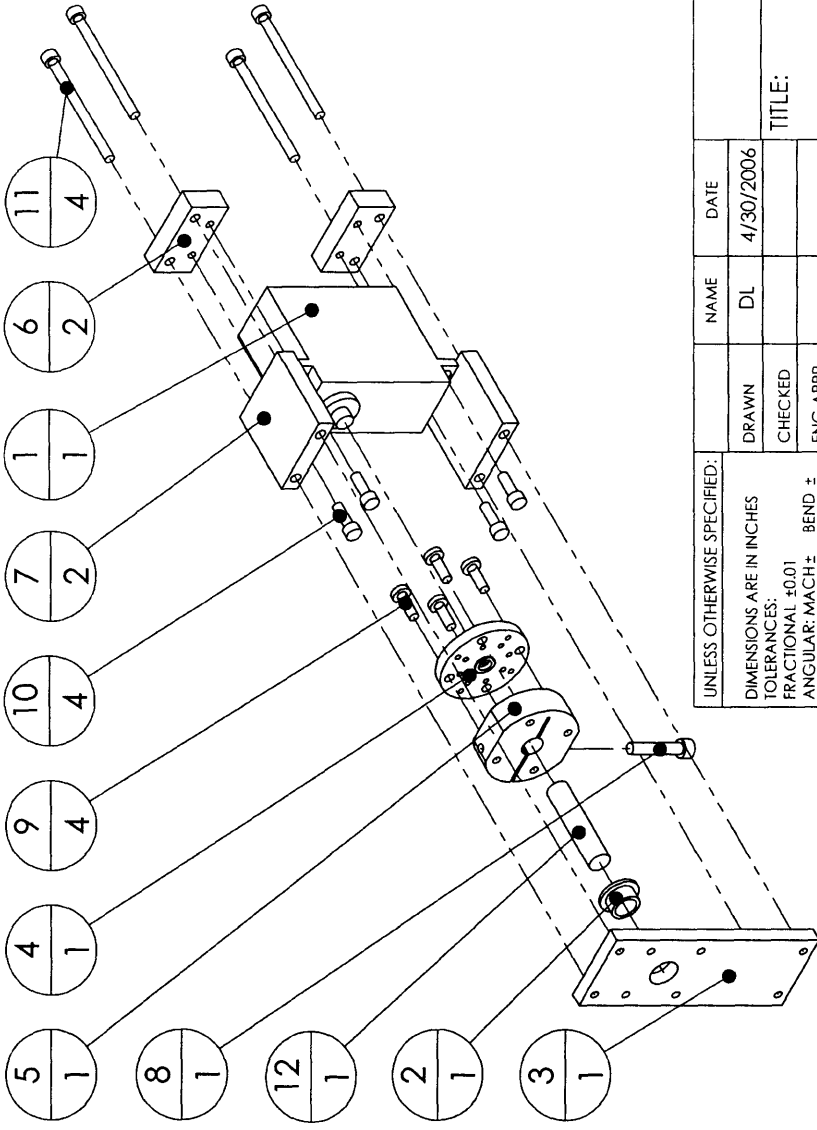

UNLESS OTHERWISE SPECIFIED:		NAME	DATE
DIMENSIONS ARE IN INCHES		DL	4/30/2006
TOLERANCES:			
FRACTIONAL ±0.01			
ANGULAR: MACH ±			
TWO PLACE DECIMAL ±0.01			
THREE PLACE DECIMAL ±0.005			
INTERPRET GEOMETRIC TOLERANCING PER:			
MATERIAL			
FINISH			
DO NOT SCALE DRAWING			
<p><b>PROPRIETARY AND CONFIDENTIAL</b>                  THE INFORMATION CONTAINED IN THIS DRAWING IS THE SOLE PROPERTY OF DAVID LAFFERTY. ANY REPRODUCTION IN PART OR AS A WHOLE WITHOUT THE WRITTEN PERMISSION OF DAVID LAFFERTY IS PROHIBITED.</p>			
TITLE: <b>Servo Mounting Assembly</b>			
SIZE	DWG. NO.	REV	
<b>A</b>	<b>servomount</b>		
SCALE: 1:3	WEIGHT: 0.99 lb	SHEET 2 OF 2	

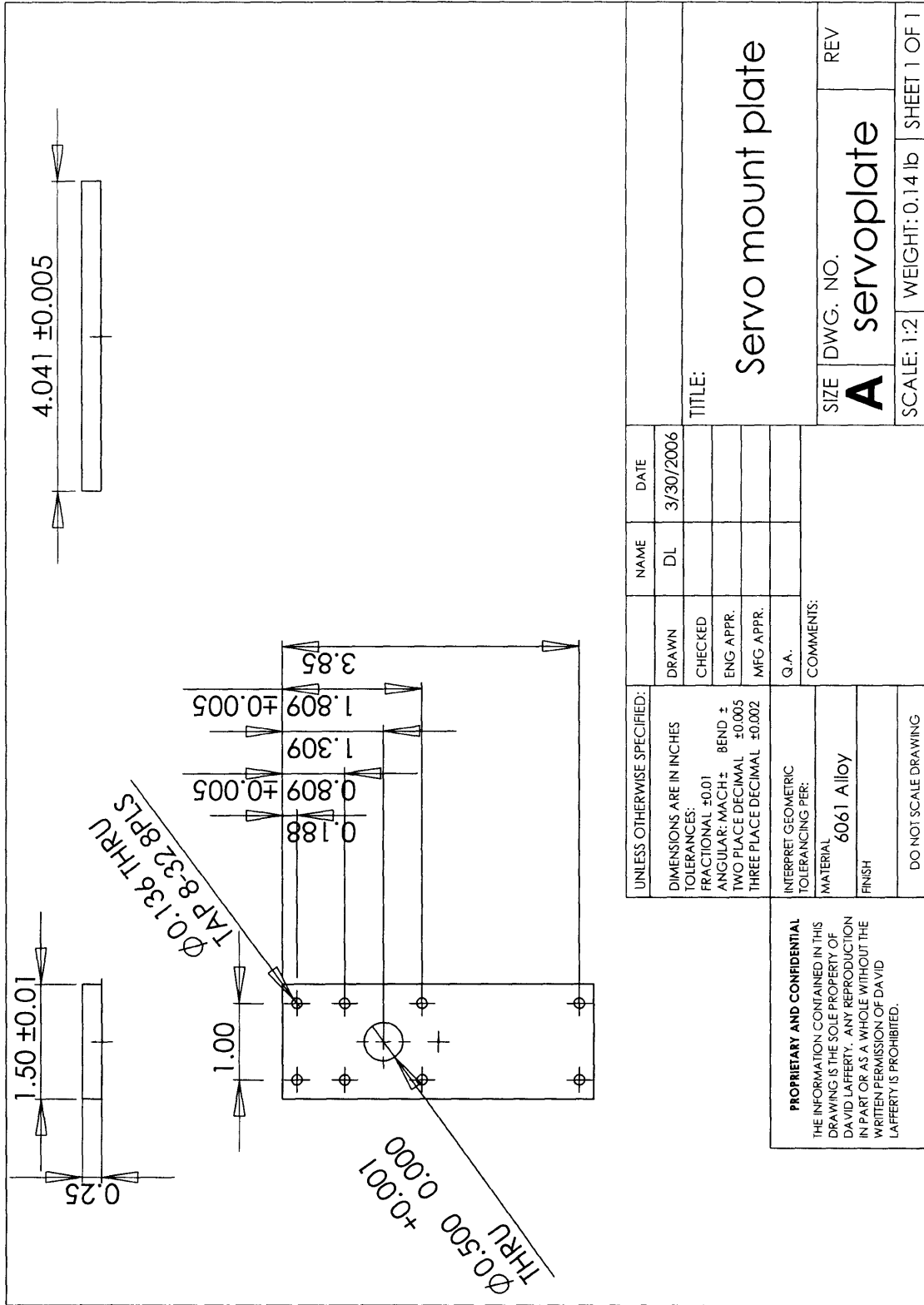

UNLESS OTHERWISE SPECIFIED:		NAME		DATE	
DIMENSIONS ARE IN INCHES		DL		3/30/2006	
TOLERANCES:		DRAWN			
FRACTIONAL $\pm 0.01$		CHECKED			
ANGULAR: MACH $\pm$ BEND $\pm$		ENG APPR.			
TWO PLACE DECIMAL $\pm 0.005$		MFG APPR.			
THREE PLACE DECIMAL $\pm 0.002$		G.A.			
INTERPRET GEOMETRIC TOLERANCING PER:		COMMENTS:			
MATERIAL 6061 Alloy					
FINISH					
DO NOT SCALE DRAWING					

**Servo mount plate**

SIZE	DWG. NO.	REV
<b>A</b>	<b>servo plate</b>	
SCALE: 1:2	WEIGHT: 0.14 lb	SHEET 1 OF 1

**PROPRIETARY AND CONFIDENTIAL**  
 THE INFORMATION CONTAINED IN THIS DRAWING IS THE SOLE PROPERTY OF DAVID LAFFERTY. ANY REPRODUCTION IN PART OR AS A WHOLE WITHOUT THE WRITTEN PERMISSION OF DAVID LAFFERTY IS PROHIBITED.

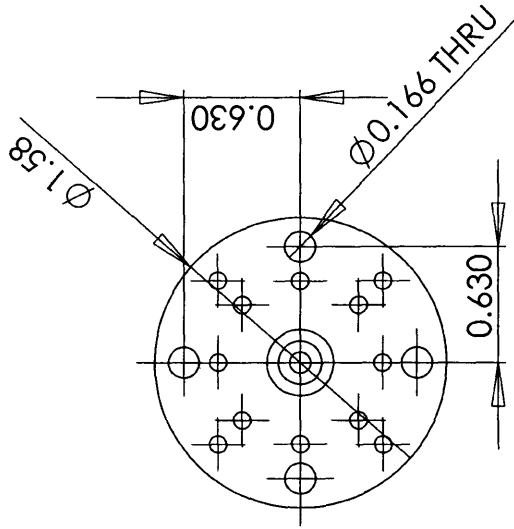
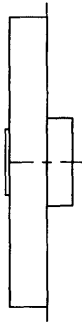
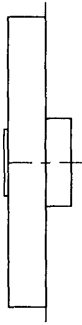

UNLESS OTHERWISE SPECIFIED:		DRAWN		NAME		DATE	
DIMENSIONS ARE IN INCHES		DL		DL		3/29/2006	
TOLERANCES:		CHECKED					
FRACTIONAL ±0.01		ENG APPR.					
ANGULAR: MACH ±		MFG APPR.					
BEND ±		Q.A.					
TWO PLACE DECIMAL ±0.01		COMMENTS:					
THREE PLACE DECIMAL ±0.005		INTERPRET GEOMETRIC TOLERANCING PER:					
MATERIAL		Nylon 6/10					
FINISH		DO NOT SCALE DRAWING					
<b>PROPRIETARY AND CONFIDENTIAL</b> THE INFORMATION CONTAINED IN THIS DRAWING IS THE SOLE PROPERTY OF DAVID LAFFERTY. ANY REPRODUCTION IN PART OR AS A WHOLE WITHOUT THE WRITTEN PERMISSION OF DAVID LAFFERTY IS PROHIBITED.		TITLE:		SIZE		DWG. NO.	
		Servo horn		A		REV	
		SCALE: 1:1		WEIGHT: 0.02 lb		SHEET 1 OF 1	

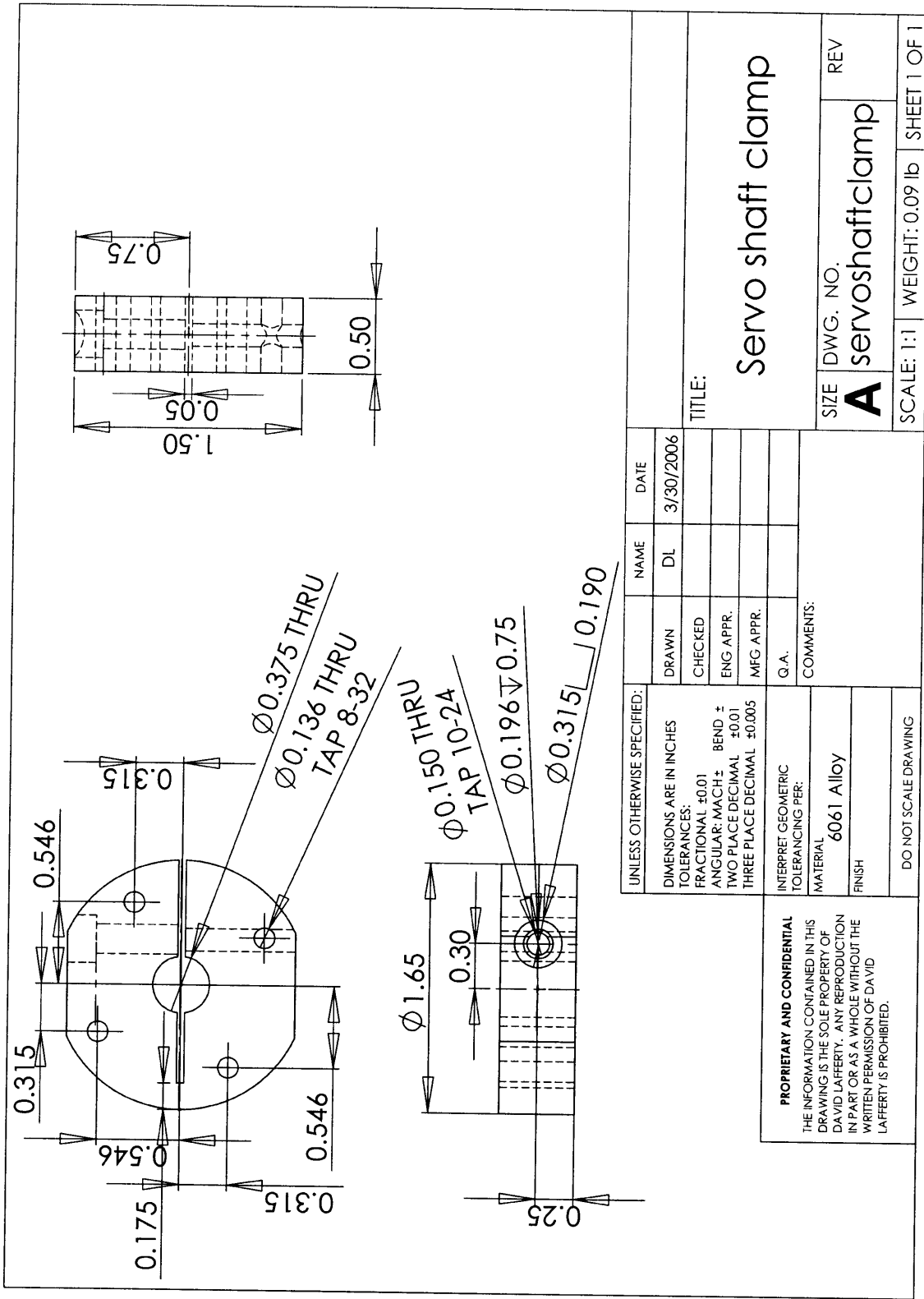



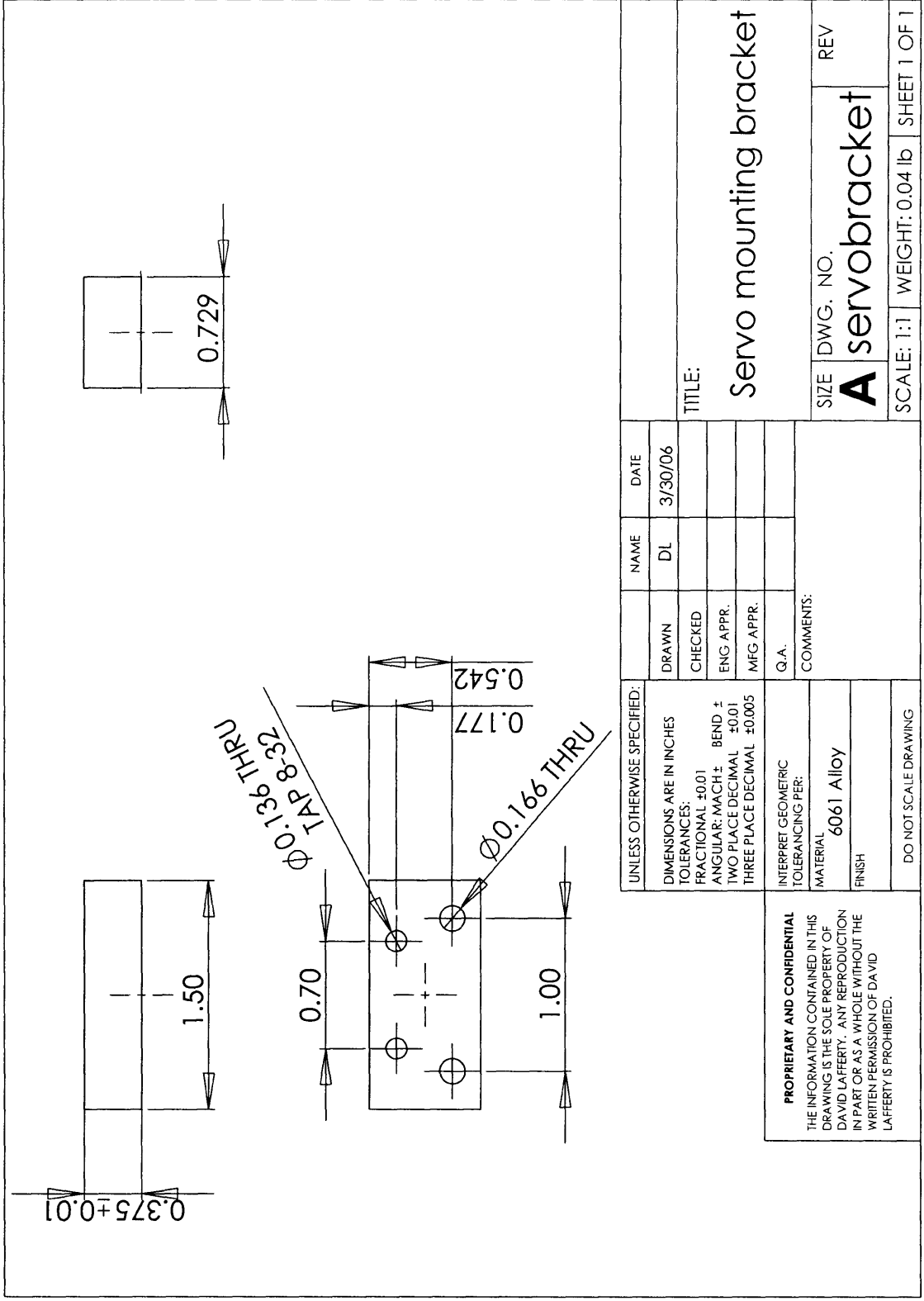

UNLESS OTHERWISE SPECIFIED:		DRAWN		NAME		DATE	
DIMENSIONS ARE IN INCHES		DL		DL		3/30/06	
TOLERANCES:		CHECKED					
FRACTIONAL ±0.01		ENG APPR.					
ANGULAR: MACH ±		MFG APPR.					
TWO PLACE DECIMAL ±0.01		G.A.					
THREE PLACE DECIMAL ±0.005		COMMENTS:					
INTERPRET GEOMETRIC TOLERANCING PER:							
MATERIAL						SIZE DWG. NO. REV	
6061 Alloy						A servobraceket	
FINISH						SCALE: 1:1 WEIGHT: 0.04 lb SHEET 1 OF 1	
DO NOT SCALE DRAWING							

TITLE: Servo mounting bracket

**PROPRIETARY AND CONFIDENTIAL**  
 THE INFORMATION CONTAINED IN THIS DRAWING IS THE SOLE PROPERTY OF DAVID LAFFEY. ANY REPRODUCTION IN PART OR AS A WHOLE WITHOUT THE WRITTEN PERMISSION OF DAVID LAFFEY IS PROHIBITED.



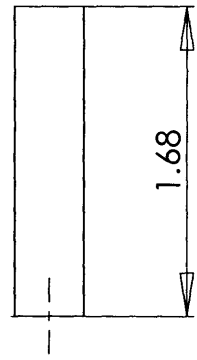
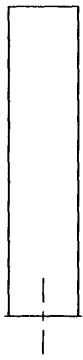
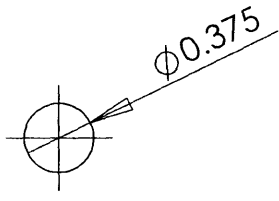

UNLESS OTHERWISE SPECIFIED:		DRAWN	NAME	DATE
DIMENSIONS ARE IN INCHES		CHECKED	DL	3/14/2006
TOLERANCES:		ENG APPR.		
FRACTIONAL $\pm 0.01$		MFG APPR.		
ANGULAR: MACH $\pm$ BEND $\pm$		Q. A.		
TWO PLACE DECIMAL $\pm 0.01$		COMMENTS:		
THREE PLACE DECIMAL $\pm 0.001$				
INTERPRET GEOMETRIC TOLERANCING PER:				
MATERIAL Alloy Steel				
FINISH				
DO NOT SCALE DRAWING				

TITLE: Shaft, 3/8"	
SIZE <b>A</b>	DWG. NO. shaft
SCALE: 1:1	WEIGHT: 0.05 lb
SHEET 1 OF 1	

**PROPRIETARY AND CONFIDENTIAL**  
 THE INFORMATION CONTAINED IN THIS DRAWING IS THE SOLE PROPERTY OF DAVID LAFFERTY. ANY REPRODUCTION IN PART OR AS A WHOLE WITHOUT THE WRITTEN PERMISSION OF DAVID LAFFERTY IS PROHIBITED.

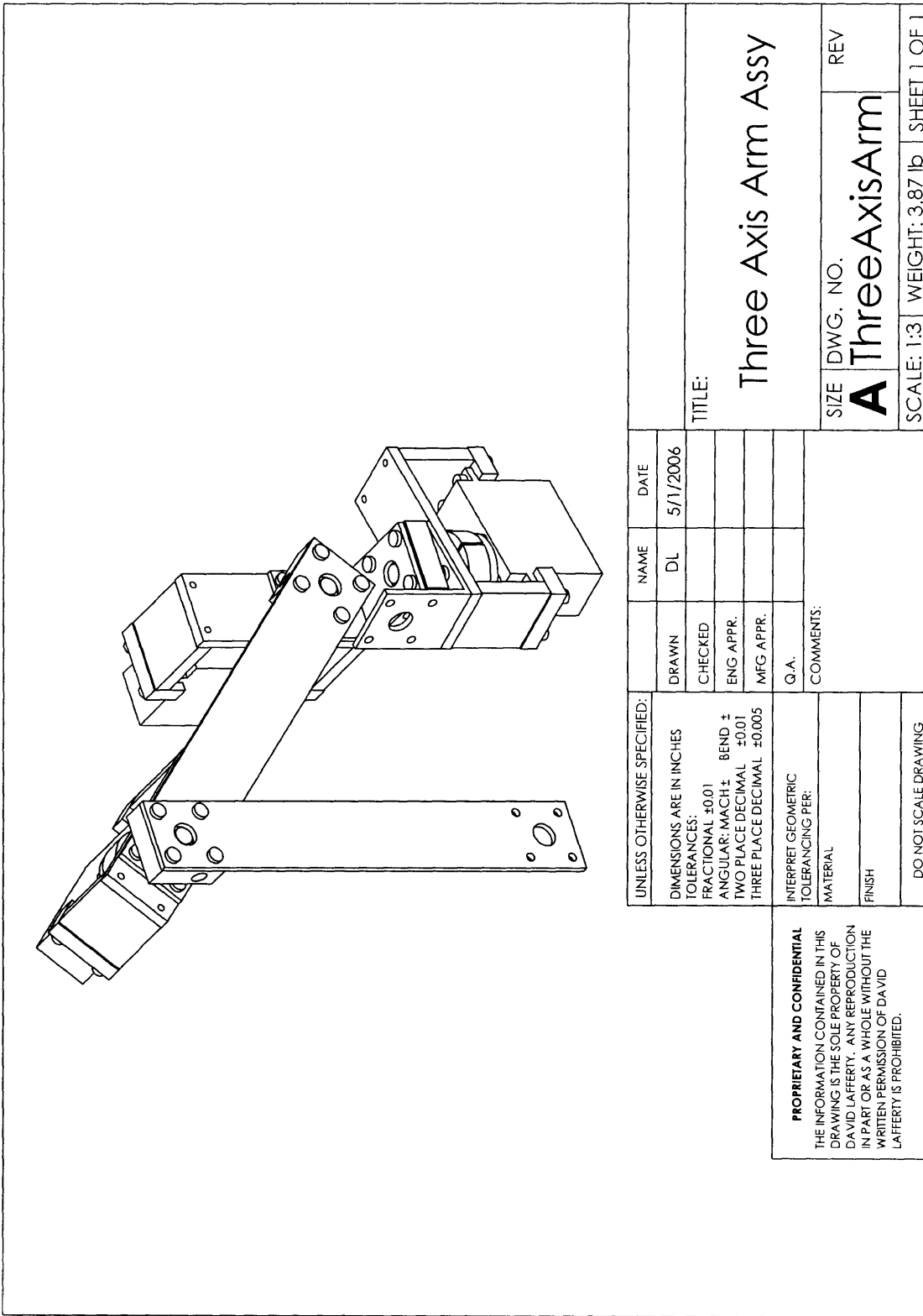

UNLESS OTHERWISE SPECIFIED:		DRAWN	DL	DATE	5/1/2006
DIMENSIONS ARE IN INCHES		CHECKED			
TOLERANCES:		ENG APPR.			
FRACTIONAL ±0.01		MFG APPR.			
ANGULAR: MACH ± BEND ±		Q.A.			
TWO PLACE DECIMAL ±0.01		COMMENTS:			
THREE PLACE DECIMAL ±0.005					
INTERPRET GEOMETRIC TOLERANCING PER:					
MATERIAL:					
FINISH:					
DO NOT SCALE DRAWING					

TITLE: Three Axis Arm Assy

SIZE DWG. NO. REV  
**A** ThreeAxisArm

SCALE: 1:3 WEIGHT: 3.87 lb SHEET 1 OF 1

**PROPRIETARY AND CONFIDENTIAL**  
 THE INFORMATION CONTAINED IN THIS DRAWING IS THE SOLE PROPERTY OF DAVID LAFFERTY. ANY REPRODUCTION IN PART OR AS A WHOLE WITHOUT THE WRITTEN PERMISSION OF DAVID LAFFERTY IS PROHIBITED.

**Three-Axis Arm Prototype Assembly**