

Design of a Minimalist Autonomous Robotic Vehicle

By

Mark Spadafora

SUBMITTED TO THE DEPARTMENT OF MECHANICAL ENGINEERING IN
PARTIAL FULFILLMENT OF THE REQUIREMENTS FOR THE DEGREE OF

BACHELOR OF SCIENCE IN MECHANICAL ENGINEERING
AT THE
MASSACHUSETTS INSTITUTE OF TECHNOLOGY

JUNE 2008

©2008 Mark Spadafora. All rights reserved.

The author hereby grants to MIT permission to reproduce
and to distribute publicly paper and electronic
copies of this thesis document in whole or in part
in any medium now known or hereafter created.

Signature of Author: _____
Department of Mechanical Engineering
9 May 2008

Certified by: _____
John J. Leonard
Professor of Mechanical and Ocean Engineering
Thesis Supervisor

Accepted by: _____
John H. Lienhard V
Professor of Mechanical Engineering
Chairman, Undergraduate Thesis Committee

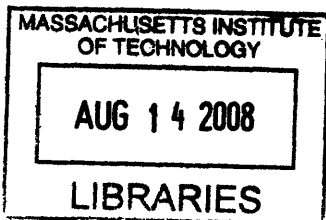

ARCHIVES

Design of a Minimalist Autonomous Robotic Vehicle

By

Mark Spadafora

Submitted to the Department of Mechanical Engineering
on May 9, 2008 in partial fulfillment of the
requirements for the Degree of Bachelor of Science in
Mechanical Engineering

Abstract

The purpose of this thesis is to investigate design alternatives for the creation of a minimalist autonomous robotic vehicle, based on the Ford Escape. The work builds on prior work performed by the MIT DARPA Urban Challenge team, which competed in the national DARPA Urban Challenge NQE and UCE events in October and November 2007. The MIT team pursued an ambitious design that was rich in both sensors and computation. The excessive amount of equipment and computing power throughout the current vehicle make it too expensive and unreasonable to go into actual production.

The goal for this work is to revisit the design approach of the MIT team, and from a Mechanical Engineering perspective, to perform a new conceptual design that would bridge the gap between the current vehicle and present in production technologies. By developing a minimalist sensor/processor configuration, the Ford Escape can more closely reflect a present day vehicle, in both appearance and cost, and be more viable for future production. Using the Ford Escape rapid prototype vehicle, the previous installation was stripped out in order to design, re-engineer, and implement a configuration that will allow new research in affordable autonomy and active safety for in-production vehicles.

Thesis Supervisor: John J. Leonard

Title: Professor of Mechanical and Ocean Engineering

Table of Contents

Abstract	2
Table of Contents	3
1. Introduction	4
1.1 Project Background	4
1.2 The Ford Escape Platform	6
2. Sensors	8
3. Computing Power	11
4. Electrical Power	13
5. Design Overview	16
References	18
Drawings	18
Radar Mount	19
Camera Mount	20

1. Introduction

1.1 Project Background

The DARPA Grand Challenge, sponsored by the Defense Advance Research Projects Agency (DARPA), is an autonomous ground vehicle competition. The competition was created to promote the research and development of autonomous vehicle technologies. The Challenge consists of fully autonomous vehicles using only equipped sensors and GPS navigation points to complete a predetermined course within a specified amount of time. DARPA set a \$1 million prize for the team that could win the competition. The first Grand Challenge took place in 2004, which involved navigating a 150-mile route through the Mojave Desert in California. None of the vehicles finished the race and the prize was left unclaimed.

The next Grand Challenge was held in 2005 once again through the Mojave Desert and the prize was increased to \$2 million dollars. The vehicles of the 2005 challenge performed better than those of the first race and this time there was a winner. The Stanford Racing Team was the first out of 5 teams to complete the race and received the \$2 million dollar prize. Now that teams had been able to complete the race, DARPA decided to hold another challenge with increased difficulty to require higher performance and technologies from the competing teams. The DARPA Urban Challenge was held in 2007 and took place at the now-closed George Air Force Base in Southern California. The new goal of this challenge was to complete a 60 mile course which involved having autonomous vehicles capable of driving in traffic as well as performing maneuvers such

as merging, passing, parking and negotiating intersections. Again a \$2 million dollar prize was set to be awarded to the winner of the race.

In July of 2006, an MIT team was formed to create an autonomous vehicle to race in the Urban Challenge. Partnered with Olin College and Draper Laboratory, the MIT team was made up of both faculty and students. Having never competed before, the team



Figure 1: The MIT Teams' Land Rover LR3¹

designed and built an autonomous vehicle using a Land Rover LR3. Their autonomous vehicle, nicknamed Talos, finished in 4th place and was one of only six teams to complete the entire race. With the Urban Challenge over, the MIT team is currently looking to improve on their technologies and continue research with autonomous vehicles. After experiencing the actual competition, the team learned a great deal about where they went wrong in there design and what they could have done differently. Working in collaboration with the Ford Motor Company, the MIT team is researching their autonomous vehicle technologies on a smaller scale that could eventually be used in commercial vehicles to help improve driving performance and safety.

1.2 The Ford Escape Platform

When the team was formed in July of 2006 before the 3rd challenge, the first vehicle purchased was a 2006 Ford Escape. While a Land Rover LR3 that was donated to the team was going to be the vehicle used in the actual competition, the team needed another vehicle that they could quickly use as a test bed to start preparing for the challenge. The team at Olin College in Needham, MA performed the physical conversions of the vehicle in order to make it a rapid prototyping platform for the technologies being created by the Urban Challenge team. By the time of the actual



Figure 2: The Ford Escape completed by Olin College²

DARPA Urban Challenge in November of 2007, the Ford Escape was no longer being used and all focus was placed on the LR3 racing vehicle. With the challenge completed, some of MIT's research focus has now been directed back to the Ford Escape vehicle.

The purpose of this thesis is to work with the MIT DARPA Challenge teams' Ford Escape platform in designing and converting it into a testing vehicle to be used as a model of a present day in production vehicle where some of the autonomous vehicle

technologies can be implemented and improved upon for use in automobile active safety. It is clear that the technology used in the DAPRA Urban Challenge is too ambitious and expensive to be considered for use in actual vehicles in its current form. The Ford Escape is a great testing bed for this type of research because it represents a typical in-production car that is common to the public population. Designing a minimalist sensor/processor configuration on the platform required taking multiple steps backwards from the state the vehicle was currently in.

The technology in the vehicle that required modifications can be broken down into three groups: sensors, electrical power, and computing power. The status of these three groups, in both the Ford Escape and Land Rover LR3 platforms, were at high extremes on both technology and cost for the sole purpose of trying to win the Urban Challenge. But for the purpose of production vehicle research, all these had to be downgraded for a more realistic product. The appearance of either vehicle in its Urban Challenge condition is that of a vehicle that would represent a vehicle from the future. Thousands of dollars worth of sensor equipment covering the outside of the vehicle and thousands of more dollars worth of computing power filling the vehicle make them extremely ahead of their time. The final LR3 competition vehicle had over \$400,000 worth of equipment added to it by the time of the race.

The cost of all the technology included on these vehicles for the challenge is too expensive to be considered for production. To be feasible, the cost of any technology added to a vehicle in production for the public needs to only represent a small fraction of the overall cost of the vehicle. The design is not feasible for production and sale when the added technology dominates the cost of the vehicle. It is also unrealistic to expect to be

able to produce a vehicle that has had almost all of its seating and storage capacity taken. Both the Ford Escape and the Land Rover LR3, being sport utility vehicles, are supposed to have ample amounts of seating and storage capacity. The excessive amount of computing power used in these vehicles required taking a lot of this space away. In the case of the Escape, a vehicle that was supposed to seat five people with a large sized trunk area was reduced to only being able to seat two and lost most storage area. This greatly inhibits the usability of the vehicle and needed to be redesigned in a minimalist configuration to allow a performance that would be expected.

2. Sensors

One of the most important parts of the strategy used by the MIT team in solving the difficult task of creating an autonomous vehicle was taking advantage of sensor technology. The MIT DARPA Urban Challenge team used a plethora of sensors on their vehicle in order to guarantee that they received all the data of the surrounding environment that they required to perform autonomous navigation. The LR3 vehicle had a wide arrangement of sensors including 15 radar sensors, 13 lidar sensors, and 5 cameras arranged around the vehicle so the computer software could “see” all of the vehicles surroundings. The Ford Escape rapid prototype had fewer sensors but still a comparable sensor layout to the LR3. These sensors were mounted on a customized front bumper, a roof platform, and on the rear of the vehicle. There is also a GPS and an IMU unit to help with navigating the vehicle.

One of the first steps involved in redesigning the Ford Escape is reducing the amount of sensors on the vehicle. The task is to use only a minimal amount of sensors

that are still capable of effectively performing tests for vehicle active safety. To be more realistic and better representing of an in production vehicle, all the sensors had to be removed from the roof platform. As seen in Figure 2, the large amount of sensor equipment on the roof is not a feasible location. The sensors are not at all protected and completely left open to the environment which could easily result in damage. Also, the sensor platform installed on the roof of the vehicle greatly reduces the storage functionality that the roof previously had. Having the platform and sensors on the roof also greatly affects the aerodynamics of the vehicle, again making this location undesirable for the sensors on the test bed vehicle. The sensors and the roof sensor platform (Figure 3) were removed from the Ford Escape to restore it to the original production configuration.

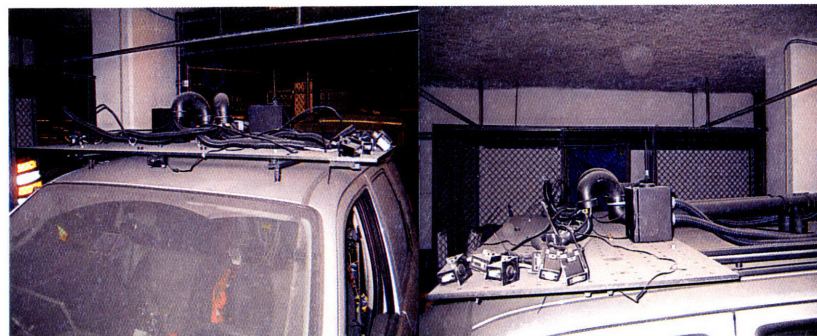

(a)



(b)

Figure 3: Ford Escape roof (a) before and (b) after platform removal

The final minimalist sensor configuration for the Ford Escape will be made up of 3-4 lidar sensors, 1-2 cameras, and a radar sensor. This is a significant reduction from the abundant amount of sensors used in preparation for the Urban Challenge. While complete autonomous driving required an extremely vast amount of data collection, the number of sensors that would be required for adding active safety to an in production vehicle could be minimal. The three SICK lidar sensors would remain on the customized front bumper built and installed by Olin College. The radar sensor would also be mounted to the front end bumper. These represent sensors that could be built in to the front end or the front bumper of a vehicle. Figure 2 shows the orientation of the sensors mounted on the front end of the Ford Escape. The radar sensor requires the design and fabrication of a mounting bracket to attach it to the top of the middle lidar sensor. Figure 4 is an image of the solid model of the radar mount and dimensioned drawings are attached.

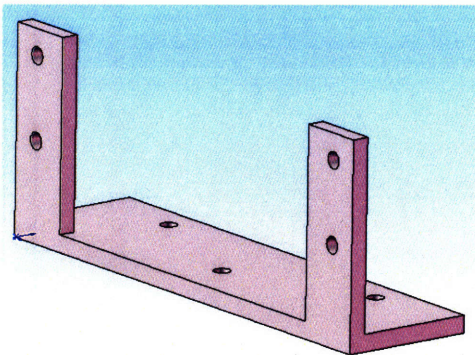

Figure 4: Radar mounting bracket

Next, one or two of the cameras removed from the roof platform will be installed inside the vehicle behind the windshield. This is more efficient because a camera installed outside the vehicle on the roof would be easily noticeable and require extra mounting equipment to protect it from the environment. By installing them inside the vehicle, the cameras can be slightly hidden from plain sight and all wiring to the cameras

can be hidden within the interior lining, also acting as a way of protecting the equipment from any damage. The current cameras that were used on the Escape vehicle had a custom mount system fabricated by Olin College. These adjustable mounts acted as both a protective case for the cameras, as well as an easy means of changing the orientation of the cameras. In order to attach the cameras inside the windshield of the vehicle and still use the adjustable mounts made by Olin College, custom brackets must be made to attach the mounts to the roof of the vehicle and lower the cameras below the roof line so they can have a visible path out the windshield. Figure 5 shows the camera mounting system produced by Olin College and the mounting bracket that will connect it to the vehicle.

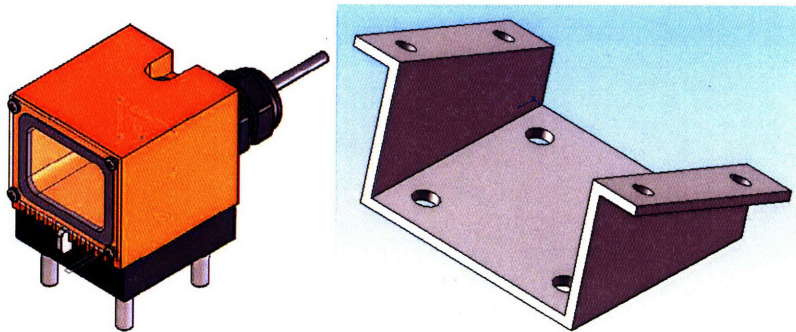

Figure 5: Camera casing system³ and mounting bracket

3. Computing Power

The next part of the conversion process involves changing the computing power within the Ford Escape vehicle. In preparation for the DARPA Urban Challenge, the MIT Team equipped their vehicle with a massive amount of computing power, using blade servers (from Quanta Computers) containing up to ten computers each, along with other custom hardware made by the team themselves. All of that computing power required both the electrical power to run them all and a cooling system to prevent them from over

heating. An air conditioning unit, which can be seen in Figure 1, was installed on the roof of the Land Rover LR3 to cool all of the computer equipment running in the trunk of the vehicle. A large amount of computers running in the confined space in the back of the vehicle also required some kind of barrier to enclose all of the sounds produced by equipment.

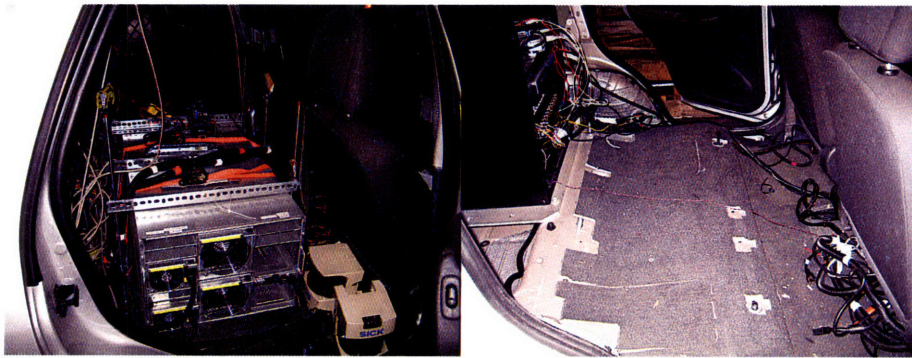

Figure 6: Back seat of Ford Escape before and after blade server removal

Lastly, the blade server required a good amount of physical space to mount it, which with respect to the Ford Escape required removing the entire back row of seats, shown in Figure 6. All these reasons express a need to minimize the amount of computer equipment as much as possible. The very high costs of using an excessive amount of computing power only results in additional costs of making modifications to the vehicle. These modifications to the vehicle for power, cooling, sound containment, and a large decrease in usable space are all unfeasible and unnecessary changes that a car company would not want to incur the cost of to add any active safety technology to their vehicles. The solution, which is also made possible by the decreased number of sensors, is to go with the minimal amount of computing power necessary to make a working system. The plan for the proposed Ford Escape testing platform is to use one or two Apple Mac Minis to run the required software.

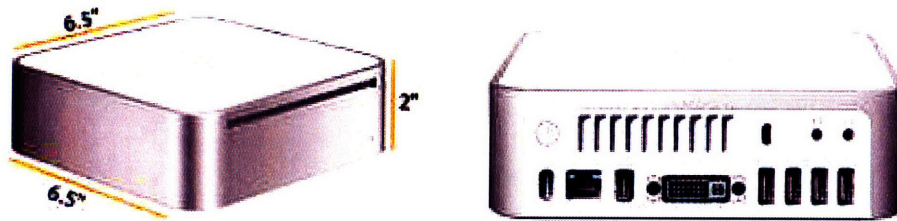

Figure 7: Apple Mac Mini computer⁴

The use of Mac Minis has many advantages, most importantly their size. The computer itself is only 6.5" x 6.5" x 2" tall. This means that the large blade server could be removed from the vehicle, allowing the back row of seats to be replaced in the Escape, and the small Mac Mini can be stored in the back trunk along with the other computer equipment because it takes up such a small amount of space. Even though the computer is small, it still is a very powerful machine. The Mac Mini has an Intel Core 2 Duo processor, room for up to 2GB main memory and 160 GB of hard drive space, and an Intel GMA 950 integrated graphics chip with 64MB shared memory. There is 1 FireWire 400 port, 4 USB 2.0 ports, AirPort Extreme wireless networking and internal Bluetooth. Two other significant benefits of using Mac Minis are that they are very quiet so no sound barrier is required and they would not need any additional cooling with only one or two running in the back of the vehicle.

4. Electrical Power

The last important conversion that needs to happen to the Ford Escape is concerning the electrical power system. Having all the sensor and computer equipment requires an additional source of power. With the Ford Escape (and the LR3), all the equipment was powered by a Honda Genset. Figure 8 shows how the gas powered

generator was suspended off the rear of the Escape vehicle (The generator was located inside the LR3, requiring venting to the outside). The Genset provided 110V AC power to the UPS, which acted as a battery backup and powered all the equipment. The system was also set up to be able to plug into a wall socket with an extension cord when it was parked in the garage. This system is not a feasible idea for the new design of the Ford Escape. Having a generator is an additional cost for the vehicle and also an undesirable hindrance to have suspended off the back of the vehicle. This impacts the way people have to drive and can also add safety concerns to the vehicle.

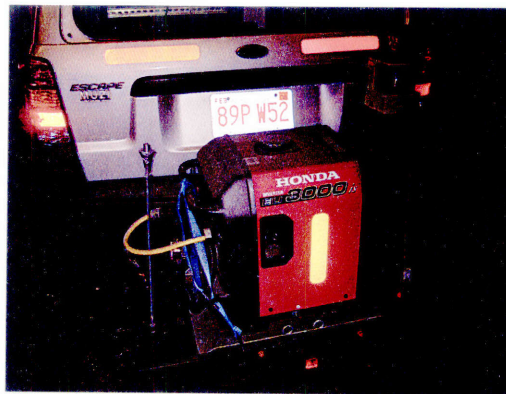

Figure 8: Honda Genset

The significant decrease in sensor and computer equipment results in a decrease in the power requirement for the vehicle. The new design is going to use an auxiliary battery off the alternator to power all the equipment, removing any need of a gas powered generator. Using a battery isolator allows the vehicle's alternator to charge the main and auxiliary battery while the engine is running. While the engine is not running, the isolator ensures that current is only drawn from auxiliary battery, preventing the main battery from dying and losing the ability to start the vehicle. A diagram of how the isolator is wired into the alternator/battery system is shown in Figure 9.

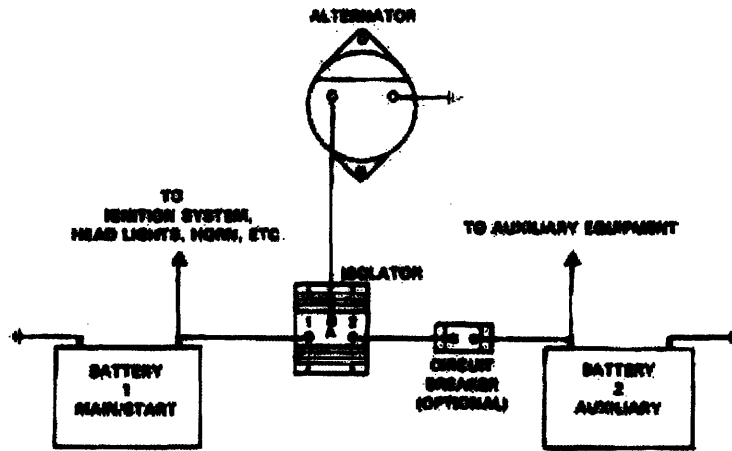

Figure 9: Auxiliary battery isolator wiring diagram⁵

The only main concern with using an auxiliary battery is ensuring that there will be enough power. There are two options depending upon the actual amount of equipment that is used in the vehicle and how much total power it all requires. The first option is to keep the stock alternator. Since the stock alternator is fairly powerful, being able to charge the battery, run the head lamps, and power other electronics in the vehicle at the same time, it is possible to use this power budget for the system. It could be possible that the alternator is not strong enough to power everything when the car is just idling, since the amount of power the alternator supplies corresponds to how fast the engine is running. This problem could be solved by increasing the RPM of the engine while it is idling to maintain enough power for the system.

If more equipment is required and the stock alternator is not enough, a higher rated replacement alternator could be used. While more reliable, this option would involve more changes to the original vehicle and incur more costs. Also, the alternator on a Ford Escape is not located in the usual position of other vehicles where it is easily accessible from the hood area. The alternator is located underneath and requires more

work to change out, only adding more costs to the process. In either instance, using an auxiliary battery would allow an easy power solution that would only require a small amount of space in the trunk area with the computer equipment (or even under the hood in the engine compartment if the car were designed for it). Also, another benefit is that this power system does not require any maintenance like the use of a generator does.

5. Design Overview

The following is a table summarizing the specifications of the original Ford Escape (*Talos-I*), the LR3 (*Talos-II*), and the presented design for the updated Ford Escape vehicle. The table displays the large increase of technology and equipment from *Talos-I*, the rapid prototyping vehicle, to *Talos-2*, the competition vehicle. The goal of

	<i>Talos-I</i>	<i>Talos-II</i>	<i>Minimalist Testing Vehicle</i>
Type of car	Ford Escape	Land Rover LR3	Ford Escape
Fly-by-wire conversion	AEVIT/EMC	AEVIT/EMC	AEVIT/EMC
IMU/GPS System	XSens /Navcom	Applanix POS LV220	XSens
Computer system	Fujitsu-Siemens BX600 Blade Cluster	Fujitsu-Siemens BX600 Blade Cluster	1-2 Mac Mini Computers
Power generation	Honda EU2000i/Honda EU3000is	Honda EVD6010 internal RV generator	Auxiliary battery/upgraded alternator
Power conditioning	APC UPS	Dual Acumentrics 2500 220V Ruggedized UPS	APC UPS
Lidars	9 SICK LMS-291 S05 lidars	12 SICK LMS 291-S05 lidars + 1 Velodyne 360 degree lidar	3 to 4 SICK LMS-291 S05 lidars
Cameras	Pt. Grey Firefly MV	5 Pt. Grey Firefly MV	1 to 2 Pt. Grey Firefly MV
Radars	1 Delphi ACC3	15 Delphi ACC3	1 Delphi ACC3

Figure 10: Vehicle Comparison⁶

the new design for the Ford Escape is achieved by minimizing the amount of sensing, computing, and powering equipment used in the vehicle. The number of sensors and

amount of additional equipment are either reduced or replaced with a cheaper alternative.

The following is a list of the parts and equipment that need to be obtained to carry out the final conversion of the Ford Escape vehicle:

Items Required

- Rear seats
- Front radar
- Inside camera(s)
- Smaller equipment rack for back
- 12 volt auxiliary battery
- Auxiliary batter case
- 12 volt auxiliary battery regulator
- 12-24 volt inverter for SICK lidar sensors
- Apple Mac Mini(s)
- Kensington power adapter(s) for Mac Mini(s)
- Small 12->110 volt inverter for laptop power and front LCD not converted
- XSENS IMU (inertial measurement unit)

This new design will allow the MIT DARPA Urban Challenge team to use all of their research and technologies to work with the Ford Motor Company in performing research on active safety that can be used in future in-production vehicles.

References

1. Dorfman, Jason. "Talos II." Photo. NQE Days 1-3. <<http://grandchallenge.mit.edu/media.shtml>>.
2. Team MIT. "Ford Escape – Talos I." Photo. <http://grandchallenge.mit.edu/wiki/index.php/Escape_status>.
3. Olin College - SCOPE Team 4. "Camera Mount System." Photo. Project: MIT/DARPA Mid-Year Report. 15 Dec 2006
4. "Mac minis." Photos. <<http://www.apple.com/macmini/design.html>> & <<http://www.apple.com/macmini/specs.html>>.
5. e-Marine, INC. "Battery Isolator Wiring Diagram." Photo. <<http://www.e-marine-inc.com/products/alternators/iso1alt2bat.html>>.
6. Team MIT. Technical Report – DARPA Urban Challenge. 13 April 2007

Drawings

The following drawings are presented for reference. Do not scale the drawings. The first drawing is of the radar mounting bracket referred to on page 10. The second drawing is of the camera mount bracket referred to on page 11.

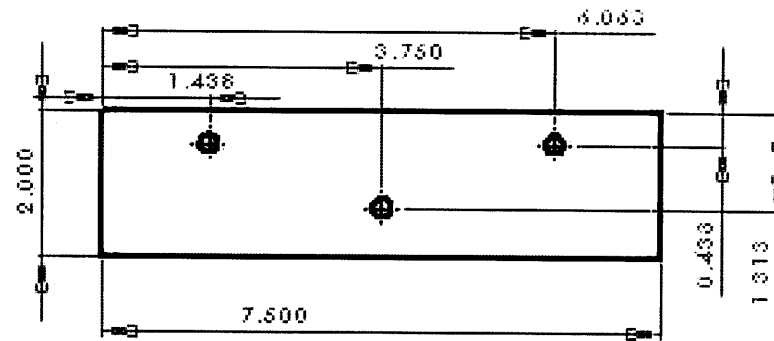
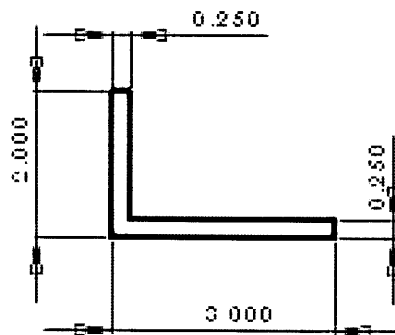
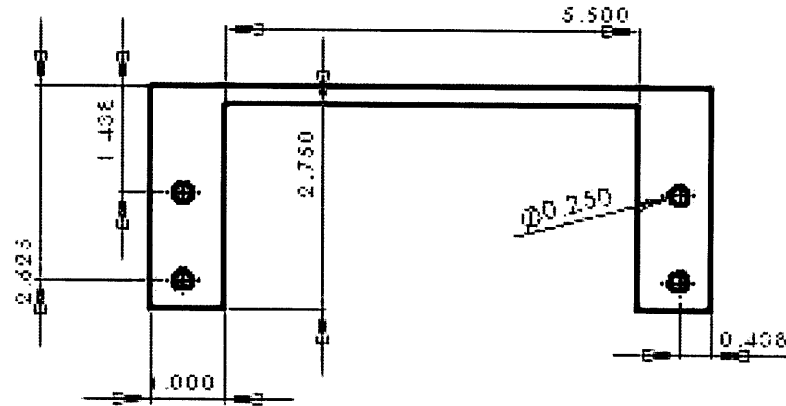
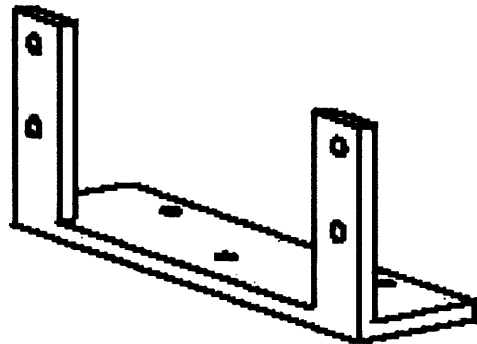

1. ALL DIMENSIONS ARE IN INCHES UNLESS OTHERWISE SPECIFIED.
 2. DIMENSIONS ARE TO CENTER UNLESS OTHERWISE SPECIFIED.
 3. DIMENSIONS ARE TO CENTER UNLESS OTHERWISE SPECIFIED.
 4. DIMENSIONS ARE TO CENTER UNLESS OTHERWISE SPECIFIED.
 5. DIMENSIONS ARE TO CENTER UNLESS OTHERWISE SPECIFIED.

6061 Alloy 6061 Alloy		DRAWN 45	DATE 3/7/03	TITLE Radar Mount
APPROPRIATE APPROVED	APPROVED APPROVED	DIMENSIONS DIMENSIONS	DIMENSIONS DIMENSIONS	DIMENSIONS DIMENSIONS
SCALE: 12 WEIGHT:		SHEET 1 OF 1		

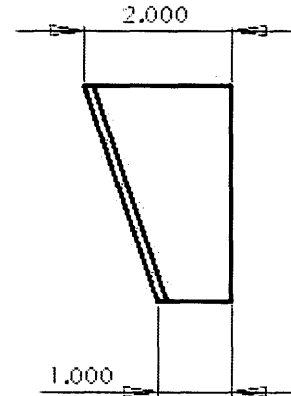
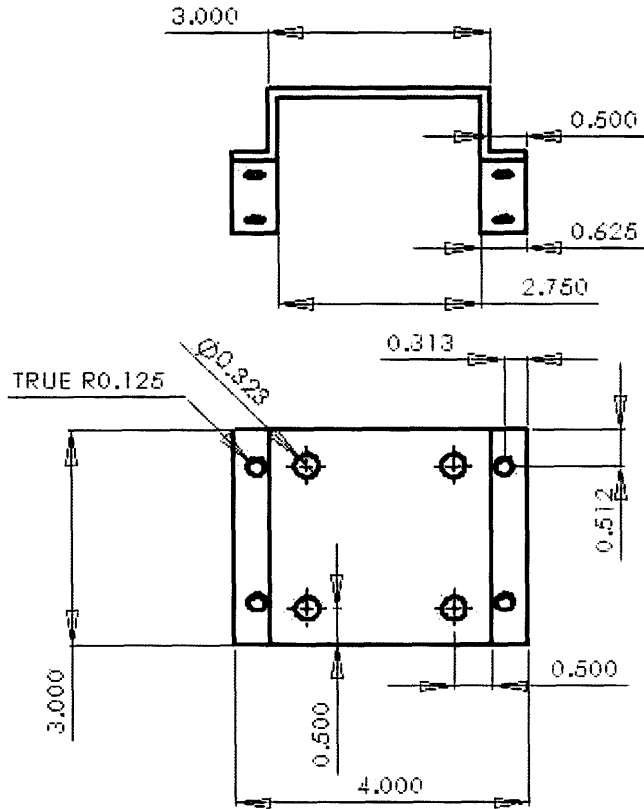
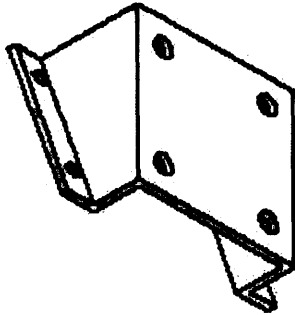
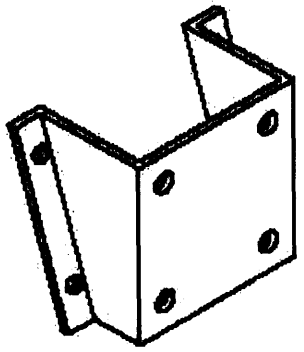

PROPRIETARY AND CONFIDENTIAL
 THE INFORMATION CONTAINED ON THIS DRAWING IS THE SOLE PROPERTY OF
 GEORGE EASTMAN COMPANY. IT IS
 NOT TO BE REPRODUCED OR TRANSMITTED IN ANY FORM OR BY ANY MEANS
 WITHOUT THE WRITTEN PERMISSION OF
 GEORGE EASTMAN COMPANY.
 10/2007

UNLESS OTHERWISE SPECIFIED:		NAME	DATE
DIMENSIONS ARE IN INCHES		MS	5/7/08
TOLERANCES:		DRAWN	
FRACTIONAL: ±		CHECKED	
ANGULAR: MACH ± 0.010		ENG APPR.	
TWO PLACE DECIMAL: ± 0.010		MFG APPR.	
THREE PLACE DECIMAL: ±		QA	
MATERIAL: 6061 Alloy		COMMENTS:	
APP'D	DATE	TITLE:	
		Camera Mount	
		SEE DWG. NO.	REV
		A	
SCALE: 1:2	WEIGHT:	SHEET 1 OF 1	