

Between Adaptation and Resistance: Labor Responses to Globalization in France

By

Marcos Ancelovici

B.Sc. Political Science
University of Montreal, 1993

M.Sc. Political Science
University of Montreal, 1995

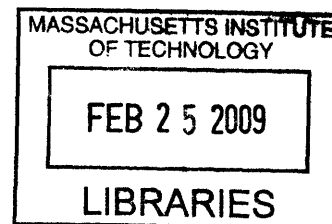

SUBMITTED TO THE DEPARTMENT OF POLITICAL SCIENCE IN PARTIAL
FULFIMENT OF THE REQUIREMENT FOR THE DEGREE OF

DOCTOR OF PHILOSOPHY IN POLITICAL SCIENCE
AT THE
MASSACHUSETTS INSTITUTE OF TECHNOLOGY

FEBRUARY 2008

© 2008 Marcos Ancelovici. All rights reserved.

The author hereby grants to MIT permission to reproduce
and to distribute publicly paper and electronic
copies of this thesis document in whole or in part
in any medium now known or hereafter created.

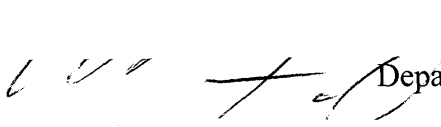
Signature of Author: _____
 Department of Political Science
October 3, 2007

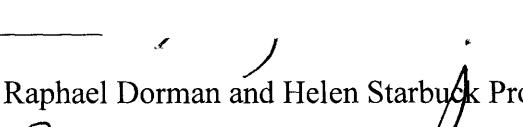
Certified by: _____
 Suzanne Berger
Raphael Dorman and Helen Starbuck Professor of Political Science
Thesis Supervisor

Accepted by: _____
Edward Steinfeld
Associate Professor of Political Science
Chairman, Graduate Program Committee

Between Adaptation and Resistance: Labor Responses to Globalization in France

By

Marcos Ancelovici

Submitted to the Department of Political Science
on October 3, 2007, in Partial Fulfillment of the
Requirements for the Degree of Doctor of Philosophy
in Political Science

ABSTRACT

This dissertation aims at accounting for labor responses to globalization in France. It addresses this issue through a comparative study of two labor organizations—the French Democratic Labor Confederation (CFDT) and the General Confederation of Labor (CGT)—that today respond differently to globalization even though they held common positions in the past: while the CGT opposes globalization, the CFDT sees it as an opportunity for French workers. I call the former response the resistance strategy and the latter the adaptation strategy.

This dissertation claims that responses to globalization are formed and transformed over time as the environment of organizations changes and intraorganizational struggles unfold. More specifically, it argues that in France the formation of labor responses to globalization stemmed from a path dependent process constituted by three different steps. First, organizational failure, illustrated by union decline, implied a critical juncture that fed intraorganizational struggles and opened the way for a reorientation of labor organizations. Second, once the crisis was acknowledged, whether organizations would take the path to adaptation or resistance depended on three factors: (1) resources inherited from the past that limit the range of options that actors can conceive and choose; (2) the presence and content of two mechanisms of change—bricolage and identity shift—that describe how actors used their inherited resources; and (3) the ability of leaders to articulate a narrative that would appeal to enough people inside their organizations so as to induce cooperation. The third and last step of this path dependent process refers to the stabilization of the new path that the CFDT and the CGT had taken. The central mechanism that stabilized these paths was a shift in the organizational opportunity structure. Although labor organizations were not completely locked in the new path, once the organizational opportunity structure had shifted it was very difficult to return to the previous path or engage in a substantially different one. Therefore, unless another critical juncture takes place, the CFDT and the CGT are likely to stick with their current responses to globalization for many years.

Thesis Supervisor: Suzanne Berger

Title: Raphael Dorman and Helen Starbuck Professor of Political Science

CONTENTS

<i>List of Figures and Tables</i>	4
<i>List of Acronyms</i>	6
<i>Acknowledgements</i>	8
 PART I: THE ANALYTICAL FRAMEWORK	
1. Varieties of Labor Responses to Globalization	10
2. An Organizational Approach	36
 PART II: THE CHALLENGES	
3. The Structural Challenge: The Crisis of Class Politics	63
4. The Competitive Challenge: The Rise of the Antiglobalization Movement	89
 PART III: THE PATHWAYS	
5. The Path to Adaptation: The Case of the CFDT	129
6. The Path to Resistance: The Case of the CGT	195
 PART IV: CONCLUSION	
7. Organizational Pathways and the Politics of Globalization	260
<i>Bibliography</i>	267

LIST OF FIGURES AND TABLES

Figures

1.1: The Growth of Parallel Summits in the World	11
1.2: International Trade and Job Security	17
1.3: International Trade and Job Creation	17
1.4: The Transformation of Labor Responses to Globalization	23
1.5: The Top Decile Income Share in France, 1900-1998	27
2.1: Repertoires and Innovation Capacity	52
2.2: Linkages and Flexibility	54
2.3: The Paths to Adaptation and Resistance	59
3.1: The Electoral Performance of the PCF and the FN in Presidential Elections	70
3.2: Net Union Density Rates in OECD Countries	71
3.3: Articles Referring to “Socialism” in <i>Le Monde</i>	73
3.4: Strikes, 1975-2005	74
3.5: Correlation Between Unemployment and Union Density in France	77
3.6: Correlation Between Unemployment and Union Density in Six OECD Countries	77
4.1: ATTAC in Leading Leftwing Newspapers	105
4.2: ATTAC’s Organizational Lineages	106
4.3: The Symbolic Redefinition of the Opposition to Globalization	123

4.4: The Rise of the Tobin Tax in Leading Leftwing Newspapers	125
5.1: Total Membership of the CFDT, 1965-1995	154
5.2: Share of Unionized Workers by Sector	156
5.3: The Identity Shift of the CFDT	170
5.4: The Boomerang Strategy	175
6.1: Total Membership of the CGT, 1960-1995	218
6.2: Total Membership of the CGT, 1945-2005 (1,000)	218
6.3: CGT Membership by Workers' Federation, 1974-1993	220
6.4: Work Councils Elections, 1966-2001	222
6.5: Electoral Performance of the PCF in Legislative Elections, 1945-2007	223
6.6: The Identity Shift of the CGT	237

Tables

1.1: The French Economy in Comparative Perspective (2003)	15
1.2: French Public Opinion in Comparative Perspective (2003)	18
1.3: Varieties of Labor Responses to Globalization	22
4.1: Public Perception of Globalization in France (1998-2005)	121
4.2: Results of Administrative Board Elections	127
5.1: Total Membership of the CFDT, 1965-1995	153
6.1: Total Membership of the CGT, 1960-1995	217

LIST OF ACRONYMS

AC!	Acting Together Against Unemployment
AFL-CIO	American Federation of Labor-Congress of Industrial Organizations
ATTAC	Association for the Taxation of Financial Transactions for the Aid of Citizens
CFDT	French Democratic Labor Confederation
CFTC	French Confederation of Christian Workers
CGC	General Confederation of Managers
CGT	General Confederation of Labor
CP	Peasant Confederation
DAL	Right to Housing
DD!!	Right Ahead
EEC	European Economic Community
ESF	European Social Forum
ETUC	European Trade Union Confederation
EU	European Union
FDI	Foreign Direct Investment
FO	Workers' Force
GAPS	Action Group for Unionization
G8	Group of Eight
ILO	International Labor Organization

IMF	International Monetary Fund
LCR	Communist Revolutionary League
MAI	Multilateral Agreement on Investment
MDC	Citizens' Movement
MEDEF	Movement of French Enterprises
MNC	Multinational Corporation
NAFTA	North American Free Trade Agreement
NGO	Non Governmental Organization
NIEO	New International Economic Order
OECD	Organization for Economic Cooperation and Development
PCF	French Communist Party
PS	Socialist Party
PSU	Unified Socialist Party
RPR	Rally for the Republic
SNCF	National Society of Rail
SMO	Social Movement Organization
SUD	Solidarity, Unity, Democracy
UN	United Nations
WFTU	World Federation of Trade Unions
WSF	World Social Forum
WTO	World Trade Organization

ACKNOWLEDGEMENTS

Writing this dissertation has taken me more time than I care to admit. Many people and institutions generously helped me along the way. First, I wish to thank my dissertation committee. Suzanne Berger went far beyond the call of duty as my thesis supervisor. She cultivates a rare balance of rigor and open-mindedness, professionalism and empathy. Throughout my graduate studies, she supported me in every possible way and consistently challenged me, pushing me to question and reformulate what I took for granted. Several years ago, as we were walking together across the MIT campus to attend a conference, I asked her whether she had ever considered another career than teaching. She answered without hesitating that she never could have done anything else. As her students witness everyday, teaching and research are her vocation. I hope in the future to convey to my students the same passion.

As late additions to my committee, Michael Piore and Jane Jenson quickly became instrumental in helping me move forward with the dissertation. Swirling conversations and email exchanges with Mike provided food for thoughts for weeks while his contacts helped me when I returned to Montreal. In 2005, Jane welcomed me at the Canada Research Chair in Citizenship and Governance, at the Université de Montréal, and provided not only office space but also, and more importantly, a warm and stimulating environment to test some ideas and write up my dissertation. Her support and willingness to discuss yet another draft were unflinching. I also thank her, as well as her colleague Laurence McFalls, for helping me prepare my job talk at McGill University in the fall 2006.

I also wish to thank two other persons who played an important role at the beginning of this project. Joshua Cohen read several drafts of my dissertation proposal and provided stimulating feedback, helping me to clarify my argument. I have strong memories of our meetings and of his astonishing intelligence and ironic wit. Although I did not end up studying the transnational mobilizations in which he was so interested, Sidney Tarrow generously welcomed me at Cornell University before I traveled to France to begin my field research. These two days during which we intensely discussed social movements made a strong impression on me and convinced me that it was worth a lifetime of study.

Throughout the years, numerous other people supported and/or provided helpful feedback on my research. In the United States, I thank Chris Ansell, David Art, Michal Ben-Josef Hirsh, Peter Hall, Frédéric Martel, and Sara Jane McCaffrey. In France, I thank Marie-Hélène Bacqué, Richard Balme, Jacques Capdevielle, Jean Chiche, Riva Kastoryano, Patrick le Galès, Nonna Mayer, René Mouriaux, Walter Nichols, Bruno Palier, Thierry Pech, Johanna Siméant, Flore Trautmann, Valéria Venturelli, and Nicolas Véron. Finally, in Canada, Francis Dupuis-Déri and Frédéric Mérand deserve special thanks for reading lengthy, half-baked draft chapters and giving useful feedback. Francis, in particular, has talked with me about my dissertation for so many years that I'm sure

there is no way I'll convince him to discuss the book that will come out of it. His intellectual camaraderie and fraternal complicity are among the things that I value the most in life.

Several universities, research centers, and foundations made this project possible. I wish to thank the MIT Department of Political Science, the MIT Center for International Studies, and the MIT Industrial Performance Center, as well as the Krupp Foundation and the Minda de Gunzburg Center for European Studies at Harvard University, for offering generous financial and institutional support. The MIT Industrial Performance Center (IPC), particularly its Director Richard Lester and secretary Anita Kafka, as well as the Globalization Study group in which I participated for almost three years, deserve special thanks for allowing me to think about globalization from a variety of standpoints that I never would have considered on my own. Most of what I know about globalization is the product of the research we carried out and the numerous inspiring meetings that we had over the years at the IPC. In Paris, I wish to thank the CEVIPOF and the American Center, both at Sciences Po, for providing me with office space and helping me to meet colleagues with similar research interests.

Finally, on a more personal note, I want to thank Silvia Dominguez for accompanying me to Paris in 2001-02, away from her home and own research field. I also thank my parents, Annick and Gaston Ancelovici, for their unwavering support, encouragements, patience, and unconditional love over all these years. None of this would have been possible without them. Alegria Ardití also generously contributed, from Chile, to making my graduate studies possible. In Montreal, Rosalie Lavoie and her daughter Olivia have opened my eyes to a new world and given me faith in life anew. Although it has nothing to do with globalization and France, Rosalie's love permeates this dissertation.

Last not least, I dedicate this dissertation to my son Matias. He came to life the very week that I started my PhD at MIT and, since then, has been asking me whether he too would be condemned to spend his life in school. It is only natural, now that I'm finally done, to reassure him and take his hand to move on.

Varieties of Labor Responses to Globalization

Since the late 1990s, mass mobilization against globalization has spread from Seattle to Porto Alegre, Mumbai, and Hong Kong. In 1999, for example, between 50,000 and 70,000 people protested against the World Trade Organization (WTO) in Seattle.¹ Two years later as many people demonstrated against the G8 summit in Genoa, Italy. In 2003, about 70,000 activists gathered in Porto Alegre, Brazil, to participate in the World Social Forum (WSF), the antiglobalization alter ego of the World Economic Forum held simultaneously in Davos, Switzerland. In 2004 around 80,000 activists participated in the first Asian edition of the WSF in Mumbai, India. Overall, the number of counter or parallel summits organized each year to protest meetings of the WTO, the International Monetary Fund (IMF), and the World Bank has increased dramatically (see Figure 1.1). Although this antiglobalization movement has been affected by the political context that followed the 2001 terrorist attacks on the World Trade Center, its mobilization remains significant (Podobnik 2004). The issue of globalization—that is, the trend towards the emergence of a globally integrated market for capital, goods, services, and labor (Berger 2000)—has

¹ All the data on antiglobalization protests is based on Podobnik (2004).

become so contentious that some commentators even claim that it threatens “to divide world opinion as nothing has since the collapse of Communism.”²

Figure 1.1: The Growth of Parallel Summits in the World

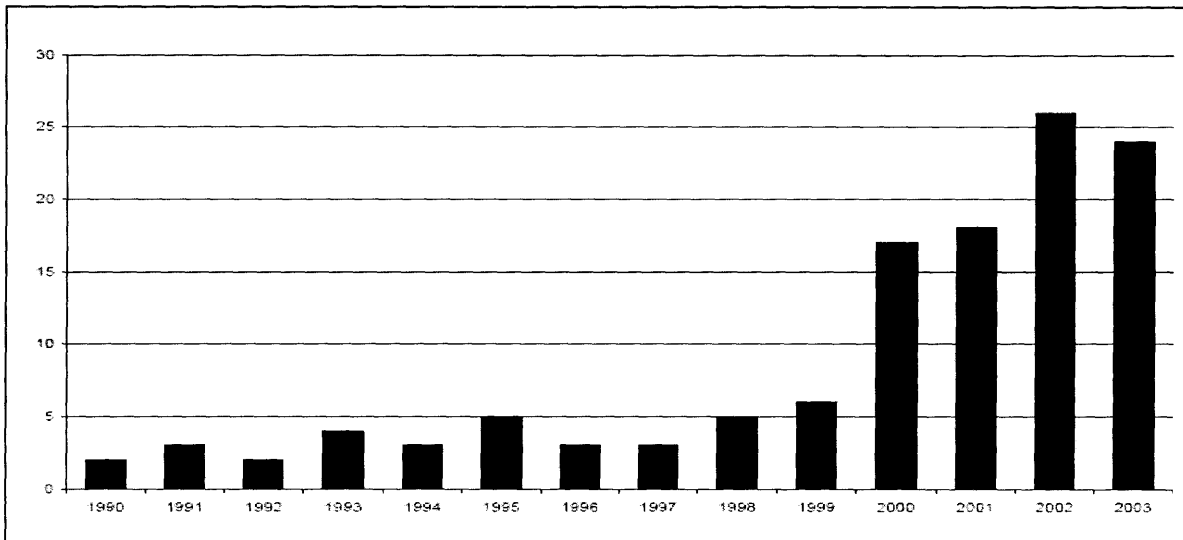

Source: Pianta, Silva, and Zola (2004: 8, Figure 1).

Organized labor plays a significant role in these mobilizations and brings the bulk of participants in demonstrations. For example, the American Federation of Labor-Congress of Industrial Organizations (AFL-CIO) mobilized the majority of protesters in the 1999 Seattle protests against the WTO. Similarly, French trade unions have been instrumental in the emergence of the antiglobalization movement in France through massive strikes and their participation in networks and organizations like the Association for the Taxation of Financial Transactions for the Aid of Citizens (Ancelovici 2002). In Italy, the Confederaazione Generale Italiana del Lavoro (CGIL) supported the organization of the 2002 European Social Forum in Florence (Della Porta 2005: 18). More generally,

² B. Crossette, “Making Room for the Poor in a Global Economy,” *New York Times*, 16 April 2000.

trade unions represent almost 45 percent of all organizations involved in the coordinating body of parallel summits (Pianta, Silva, and Zola 2004: 11, Figure 4) and have been at the center of mobilizations against free trade in the Americas (North American Free Trade Agreement [NAFTA] and the Free Trade Area of the Americas [FTAA]) as well as of global campaigns against the third world debt like Jubilee 2000.

This active opposition to globalization is also apparent in the positions of labor or leftwing parties. In France, a recent study showed that leftwing parties tend to blame foreign competition and demand the enforcement of global labor and environmental standards whereas rightwing parties focus on the “rigidities” of labor markets and call for deregulation.³ This divide is confirmed by a comprehensive comparative analysis of parties’ electoral manifestos in 25 developed countries that shows that “Left-wing parties in advanced industrial countries advocate more protectionist policies than do right-wing parties” (Milner and Judkins 2004: 114).

How can we explain this opposition to globalization? The answer to this question is not as obvious as it may seem, for some evidence shows that some labor organizations actually believe that globalization *benefits* workers worldwide. Therefore, what are the mechanisms and processes leading organized labor to respond to globalization in one way rather than another? Do the alignments underlying the politics of globalization reflect new social cleavages created by changes taking place in the international economy? This dissertation addresses these questions through a comparative study of two labor

³ Gérard Grunberg, “Le grand retour du conflit gauche-droite,” Telos-eu, posted on May 29, 2006 (http://www.telos-eu.com/2006/05/le_grand_retour_du_conflit_gau.php). Grunberg’s article is based on a recent survey of French deputies seating at the National Assembly: “Les députés français et la mondialisation: résultats de l’enquête,” http://www.telos-eu.com/2006/05/les_deputes_francais_et_la_mon-print.php. For a discussion of the results, see Zaki Laïdi, “La mondialisation: un clivage gauche / droite,” Telos-eu, posted on May 29, 2006 (http://www.telos-eu.com/2006/05/mondialisation_un_clivage_gauc.php).

organizations in France—the French Democratic Labor Confederation (CFDT) and the General Confederation of Labor (CGT), the two leading French labor confederations—that have responded differently to globalization: while the CGT opposes globalization, the CFDT sees it as an opportunity for French workers.

In this introductory chapter, I first explain why France is particularly relevant for studying labor responses to globalization. Second, I lay out the particular varieties of labor responses observable in France. Third, I discuss the potential contribution of economic and institutional perspectives. Fourth, I introduce the general argument of this dissertation. I draw upon resource mobilization perspectives in social movement theory and political-institutionalist perspectives in organizational theory (Campbell 2004, Fligstein 1987, 1996, Harmel and Janda 1994, McCarthy and Zald 1977, Panebianco 1988, Tilly 1978, Wilson 1995) so as to argue that labor responses to globalization stem from the interaction between, on the one hand, socio-economic and political-institutional changes that undermined the ability of organizations to mobilize critical resources and, on the other, organizational processes. More specifically, starting in the late 1970s French trade unions faced a structural challenge that entailed a crisis of institutionalized resource mobilization patterns associated with class politics. In attempting to solve this maintenance crisis, they embarked upon distinctive developmental pathways that eventually led them to favor one type of response to globalization over another even though they had held common positions in the past. In the late 1990s, these unions faced a competitive challenge—the rise of the antiglobalization movement—that did not involve a critical juncture, as the structural challenge, but nonetheless contributed to consolidating the path they had taken

when they reacted to the structural challenge. Finally, the last section of this chapter provides a general overview of the dissertation.

1 | WHY STUDY *FRENCH LABOR ORGANIZATIONS*?

France is particularly relevant to study the politics of globalization because it is among the most internationalized countries in Europe and one where public opinion is incredibly hostile to globalization.

The French economy has been opening up. Trade—exports plus imports—as a share of French GDP has increased from 24.9 percent in 1962 to 50.33 percent in 2003, below Germany (67.02 percent) but in line with other leading European economies (trade represents 51.08 percent of the Italian GDP and 53.72 percent of the British GDP) and twice as much as Japan (22.07 percent) and the United States (23.65 percent).⁴ Similarly, it is one of the primary sources and destinations of direct investment in the world. Between 1994 and 2001 it welcomed on average \$32 billion of foreign direct investments a year (inward FDI) and invested \$65.5 billion a year abroad (outward FDI), thereby ranking among the top countries (see Table 1.1).⁵ Inward FDI is a source of employment in the receiving country. In 2003, France was among the countries with the highest share of employment in affiliates under foreign control. This phenomenon is concentrated in manufacturing, where that share represents 26.80 percent of total employment compared to 10.97 percent for Italy, 12.77 percent for the United States, 14.96 percent for Germany,

⁴ Gordon and Meunier (2001: 4); World Bank, *World Development Indicators*, 2006.

⁵ OECD, FDI Flows.

and 25.68 percent for the United Kingdom.⁶ The jobs of much of the French manufacturing workforce are thus dependent on foreign capital.

Table 1.1: The French Economy in Comparative Perspective (2003)

Country	Trade as share of GDP (%)	Inward FDI flows, average 1994-2001 (billion USD)	Outward FDI flows, average 1994-2001 (billion USD)	Share of employment in affiliates under foreign control (as % of total employment)	
				Manufacturing	Services
France	50.33	32.0	65.5	26.80	5.2
Germany	67.02	43.8	55.6	14.96	7.2
Italy	51.08	6.5	10.5	10.97	5.1
Japan	22.07	4.3	25.9	N/A	N/A
United Kingdom	53.72	55.6	100.2	25.63	11.6
United States	23.65	150.4	126.7	12.77	3.8

Sources: World Bank, *World Development Indicators*, 2006; OECD, *Factbook*, 2006.

France is also particularly interesting to study the politics of globalization because its public opinion is more hostile to globalization than most countries in the world (see Figures 1.2 and 1.3, and Table 1.2). 80 percent of the French believe that international trade is bad for job security, compared to 67 percent of Americans and 22 percent of the Chinese; and in spite of France's trade surplus throughout the 1990s 73 percent of the French consider that trade is bad for creating jobs in their country, compared to 60 percent of Americans and 15 percent of Mexicans. Similarly, according to a 2003 Eurobarometer survey on public attitudes towards globalization, 53 percent of the French think that

⁶ OECD, *Factbook*, 2006. It is worth pointing out that this phenomenon is concentrated in manufacturing. For services, employment in affiliates under foreign control represents only 5.2 percent of total employment whereas it represents 7.2 percent in Germany and 11.6 percent in the United Kingdom. The countries with the highest share of employment in manufacturing of affiliates under foreign control were Ireland (48.37 percent), Luxembourg (45.92 percent), Hungary (42.39 percent), Sweden (34.76 percent), Belgium (34.48 percent), the Czech Republic (28.63 percent), and then France, ranking 7th.

globalization has a negative effect on economic growth in their country, compared to 29 percent of the Italians and the British and 42 percent of the Germans. In spite of the good performance of French multinationals abroad (cf. Gordon and Meunier 2001: 26-28), only 40 percent of the French believe that globalization represents a good opportunity for their national firms compared to 61 percent of the Germans and the British and 63 percent of the Italians. 58 percent of the French consider that globalization is a threat to employment and firms in their country whereas only 32 percent of the Italians and 35 percent of the Germans and the British think so. Similarly, 71 percent of the French believe that globalization has a negative effect on employment in their country compared to 39 percent of the Italians, 42 percent of the British, and 63 percent of the Germans. The French are also more pessimistic than their fellow Europeans. 47 percent believe that if globalization intensifies in the future it will be less advantageous for them and their families, compared to 25 percent of the Italians, 29 percent of the British, and 34 percent of the Germans.

France is also the European country where the antiglobalization movement is seen most favorably. The 2003 Eurobarometer survey indicates that 88 percent of the French think that the antiglobalization protests that take place during international summits raise points that deserve to be debated, compared to 75 percent of the British, 78 percent of the Italians, and 84 percent of the Germans. 41 percent also believe that the antiglobalization movement succeeds in influencing national policy-makers, compared to 30 percent of the Italians, 33 percent of the Germans, and 37 percent of the British. Contrary to the common critique that opponents of globalizations offer no concrete alternative to globalization, 47 percent of the French consider that they propose concrete solutions whereas only 32 percent of the Italians, 33 percent of the British, and 44 percent of the Germans think so.

Finally, it is worth pointing out that France is the European country where the United States is most criticized for having too much influence on the process of globalization (83 percent).

Figure 1.2: International Trade and Job Security

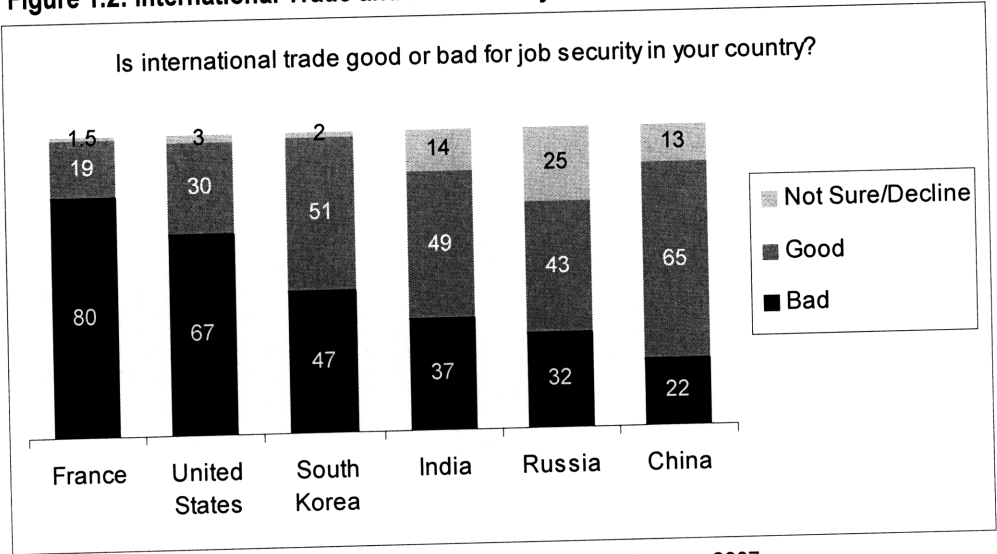

Source: The Chicago Council on Global Affairs / WorldPublicOpinion.org, 2007.

Figure 1.3: International Trade and Job Creation

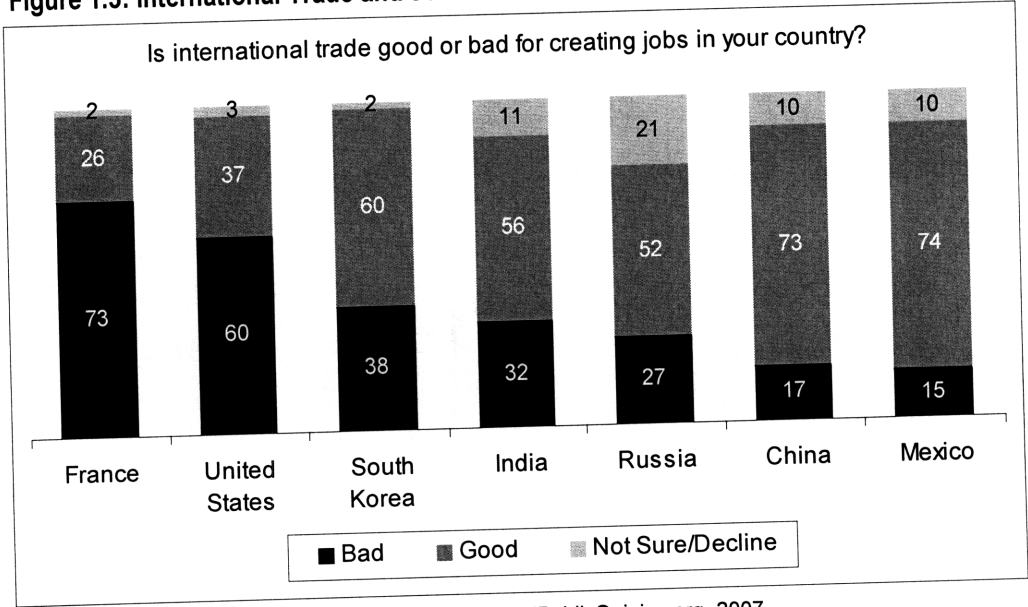

Source: The Chicago Council on Global Affairs / WorldPublicOpinion.org, 2007.

Public Opinion in Comparative Perspective (2003)

Globalization represents a good opportunity for firms in our country	Globalization represents a threat for employment and firms in our country	Globalization has a rather negative effect on employment in our country	Intensification of globalization would be less advantageous for me and my family	Favorable to the development of globalization	Antiglobalization movement raises points that deserve to be debated	Antiglobalization movement succeeds in influencing national policy-makers	Antiglobalization movement proposes concrete solutions	Unfavorable influence of globalization
40	58	71	47	63	88	41	47	
61	35	63	34	71	84	33	44	
63	32	39	25	67	78	30	32	
61	35	42	29	60	75	37	33	

Numbers are percentages.

Source: Eurobarometer, "Globalization," Flash Eurobarometer 151b, 2003.

Considering such widespread negative perception of globalization, the likelihood that French organized labor would be deeply opposed to globalization is even higher. Furthermore, several studies (Moody 1997: 15-19, Rodrik 1997: 41-44) have presented the massive strikes that paralyzed France in December 1995 as emblematic of labor's resistance to globalization. According to Dani Rodrik (1997: 41): "The widespread popular support of these strikes in France, going beyond those whose interests were immediately at stakes, is indicative of the deep nerve that the conflict between international integration and domestic institutions has struck." However, most studies of French and, more generally, labor responses to globalization downplay or overlook *positive* responses to globalization. In fact, as I explain below, in France we can observe two types of labor responses to globalization.

2 | VARIETIES OF LABOR RESPONSES IN FRANCE

By "labor response to globalization," I mean the way organized labor intervenes in public debates around the issue of globalization. I do not look at the specific demands that local unions make as they engage in collective bargaining, but treat instead trade unions as national political actors (cf. Streeck and Hassel 2003). This perspective makes it relevant to focus on peak-level associations rather than individual unions.⁷ Moreover, the high level of centralization in France means that social actors must be present at the national or state

⁷ Marks (1989: 5-6) criticizes this perspective for ignoring the decentralized structure of most labor movements and the diversity that individual unions embody. Although Marks is right to stress this diversity, it is primarily peak-level associations that voice labor's concerns in national public debates. Even if the positions of individual unions differ from that of the confederation to which they are affiliated, the latter usually speaks in their name.

level and target the very top of the political system if they want to be heard (Berger 1972: 9). In France, peak-level labor organizations are called confederations. Confederations like the CGT and the CFDT are equivalent to American federations like the American Federation of Labor and Congress of Industrial Organizations (AFL-CIO). Each confederation is constituted by a series of affiliated workers' federations (e.g., metalworkers' federation, textile-apparel workers' federation, etc.). The CFDT has 18 federations whereas the CGT has 31 federations. These workers' federations are similar to what is called national or international unions in the United States.

In French public debates, there is at first glance a consensus among French labor organizations. They all call for the implementation of a global tax on capital mobility so as to reduce financial speculation and fund the development of poor countries, demand a reform of international financial institutions (IMF, World Bank, WTO) as well as the enforcement of global labor and environmental standards, and oppose the privatization of public services and the spread of genetically modified organisms.

Beyond this general consensus, however, we can observe today a diversity of strategic responses to globalization among labor organizations. For analytical purposes, I group these responses under two broad labels: *adaptation* and *resistance* (see Table 1.3).⁸ As I will show in Chapter 6, the “resistance strategy” is primarily defensive and sees globalization as a neoliberal project that ought to be resisted. It systematically blames globalization for boosting social inequalities and undermining democracy and demands the

⁸ In labeling these two responses “adaptation” and “resistance,” no judgment is being made on their appropriateness and viability. This is the language that actors use to frame their own actions. I am not claiming that unions should respond in one way or another or that one type of response will be more effective than the other. As a matter of fact, in the 1990s both the CFDT and the CGT were doing better, regardless of the way they had responded to globalization. Finally, these labels do not suggest that some organizations adjust to changes in their environment while others simply oppose them. Both the adaptation strategy and the resistance strategy are adjustments to environmental changes.

protection of national industries, the defense of social rights, and the reform of international institutions. Furthermore, it implies promoting and participating in civic, deliberative forums as means to make collective decisions and investing resources in alliance building with extra-institutional challengers like the antiglobalization movement so as to develop a social front against market forces. The resistance strategy was developed by the General Confederation of Labor (CGT).

As I will show in Chapter 5, the “adaptation strategy,” in contrast, depicts globalization as an objective fact that requires adjustment. Albeit it opposes neoliberalism, defends social rights, and demands the reform of international institutions, like the first type of response, it also explicitly accepts the logic of the market economy and develops policy proposals congruent with a reform of state intervention. Instead of protectionism, it favors an offensive agenda that includes liberalization with social measures targeted at the losers of globalization and an industrial policy aimed at industrial upgrading so as to improve the comparative advantage of French firms in the international economy. Finally, this strategy entails efforts to engage in social concertation and partnership with employers and the refusal to build alliances with the antiglobalization movement. The adaptation strategy was developed by the French Democratic Labor Confederation (CFDT).

Rather than opposing globalization as such, the adaptation strategy supports a regulated or “managed” globalization—that is, a globalization governed by clear, written rules and multilateral institutions wherein states can negotiate fair global agreements—that provides an alternative to the ad hoc, *laissez-faire* globalization based on bilateral trade agreements promoted by the United States (Abdelal 2006, Abdelal and Meunier 2006, Gordon and Meunier 2001). This approach focuses on procedural principles rather than

substantive outcomes. Supporters of the resistance strategy also talk of managed globalization, but for them the concept means limiting capital mobility and trade. They denounce the rules of globalization as well as its alleged outcome.

These responses are strategic not in Alfred Chandler’s sense of an explicit plan characterized by long-term goals and a corresponding course of action and allocation of resources (cf. Fligstein 1987: 46), but in Henry Mintzberg’s sense of “a pattern in a stream of decisions” (Mintzberg 1978: 935). Mintzberg’s approach entails tracing not so much the formulation of strategies as their gradual and potentially unintentional formation and transformation over time as leaders make decisions one step at a time. It follows that strategic responses to globalization are not a one-shot event but a process. It is the accumulation and convergence of successive decisions and shifts over time that eventually constitute these responses. From this stand point, we need to account for the persistence as well as transformation of strategies.

Table 1.3: Varieties of Labor Responses to Globalization

	Radical Strategy (1970s)	Adaptation Strategy (1990s)	Resistance Strategy (1990s)
Policy position	Offensive: antiglobalization as socialist anticapitalism	Offensive: liberalization and managed globalization	Defensive: protection and antiglobalization
Understanding of globalization	Imperialism	Fact	Neoliberal project
Allocation of resources	Investment in alliance-building with labor parties	Investment in membership recruitment	Investment in alliance-building with other trade unions and social movements
Relation with the anti-globalization movement	N/A	Divergence	Convergence
Tactic	Protest and participation in electoral politics	Social partnership, concertation	Social front, protest
Case	CFDT and CGT	CFDT	CGT

Both the adaptation and the resistance strategy share a common root in a previous type of labor response to globalization. In the 1970s, all the largest French trade unions opposed globalization through what I call a “radical strategy.” The latter was intertwined with the radicalization of the French left and involved a very offensive agenda that suited the culmination of class politics in France. This response presented globalization as imperialism and opposed it in the name of socialism and anticapitalism. It favored the defense of the domestic market, advocated nationalizations, and implied investing substantial resources in alliance-building with political parties in the hope that an electoral victory of the left would greatly advance working-class interests. Although they embody different paths, the adaptation and the resistance strategy derive from the radical strategy (see Figure 1.4). Explaining today’s labor responses to globalization requires thus that we trace them back in time and account for their transformation.

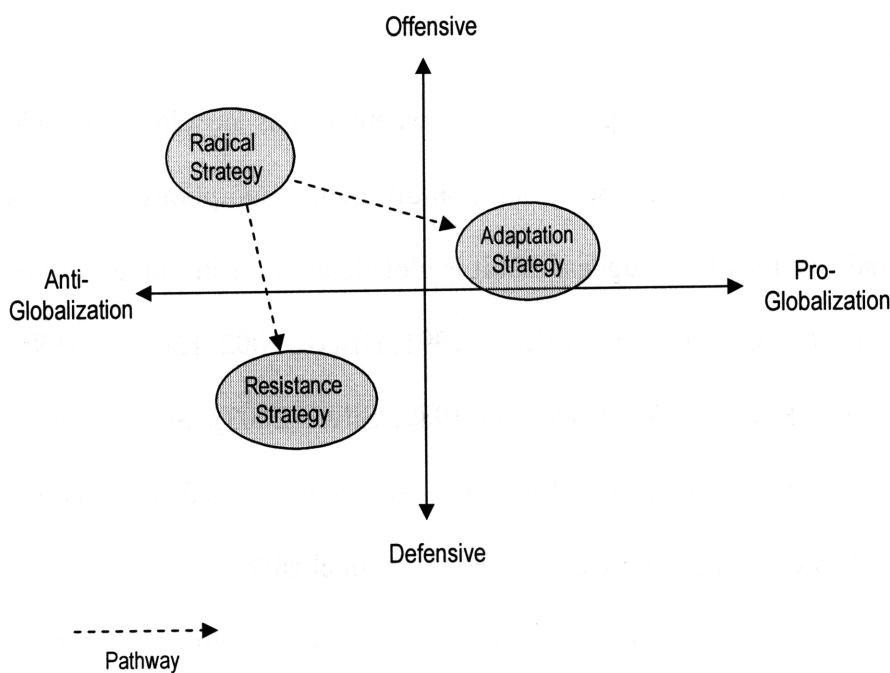

Figure 1.4: The Transformation of Labor Responses to Globalization

3 | ASSESSING POTENTIAL EXPLANATIONS

There are two different ways, broadly speaking, to answer the questions that drive this dissertation. One way consists in postulating that labor holds a given set of material interests and that its response to globalization reflects the impact of changes taking place in the international economy. This is the road taken by economic and structuralist perspectives. The second perspective assumes that domestic institutions are the key explanatory variable and focuses on the way they structure labor's options and, thereby, responses. I argue that this institutionalist perspective provides a better account of varieties of labor responses to globalization but nonetheless suffers from limitations that make certain amendments necessary.

3.1. The Economic and Structuralist Perspectives

Although the economic and structuralist perspectives—whether it is neoclassical trade economics, Marxism, or Polanyian approaches—build on different assumptions and focus on different levels of analysis, they both suggest that it is globalization itself that generates labor protest and resistance (cf. Castells 1997, Frieden 1991, Hiscox 2002, Kapstein 1996, Moody 1997, Munck 2002, Rodrik 1997, Rogowski 1989, Silver 2003). Such claim is problematic because it assumes that in advanced industrial economies globalization is bad for labor. In this respect, however, the empirical evidence is inconclusive.

Globalization can be bad for labor in three different ways. First, insofar as “employers and the final consumers can substitute foreign workers for domestic workers

more easily—either by investing abroad or by importing the products made by foreign workers” (Rodrik 1997: 16)—globalization can negatively affect wages as well as foster unemployment and inequality. If trade takes place with low-wage countries well endowed in low and semi-skilled workers, the domestic demand for these workers in advanced industrial economies will decrease while demand for highly skilled workers will increase. The resulting rise in skill premium will deepen inequality between low and semi-skilled workers, on the one hand, and highly skilled workers on the other. Globalization can be bad for labor even if trade takes place with other advanced industrial economies with similar factor endowments, because the employers’ rising capacity to substitute domestic workers with workers in other countries can foster a discrepancy between the span of union control over wages and the size of the product market: “One result of the inability of organized workers labor to coordinate wages and conditions across the entire product area is that unions can be whipsawed into competing with each other across national borders, leading to a deterioration of wages” (Golden 2000: 8).

Second, globalization can be bad for labor by fostering a convergence of labor market institutions toward a strongly decentralized Anglo-American model of industrial relations in which organized labor has a lower bargaining power than in social-democratic or coordinated models (Scruggs and Lange 2002). A weaker organized labor entails lower wages and lower job security as well as poorer working conditions. Employers can advance such shift in industrial relations by invoking the need to be competitive in the world economy and using the threat of exit if unions try to oppose some form of resistance. This asymmetry between capital’s mobility and labor’s territorial rootedness would thus foster a race to the bottom (Golden 2000: 11).

Third, globalization can be bad for labor by inducing a shift of the tax burden in favor of capital and by undermining the capacity of governments to provide social insurance to citizens (Rodrik 1997). “This is purportedly the case because, in the presence of international capital mobility, governments must encourage internationally mobile firms to remain in the domestic economy, induce foreign enterprises to invest, and allay international financial markets fears of high taxes, inflationary pressures, and economic inefficiency associated with moderate to large welfare states” (Swank 2002: 2). Consequently, globalization allegedly hurts labor by increasing the cost and, thereby, likelihood of implementing policies that benefit workers. This argument implicitly suggests that nation-states are losing their autonomy and domestic policies are converging toward a lowest-common denominator.

These three claims about the negative impact of globalization on labor are not clearly supported by evidence. Several authors (Hirst and Thompson 1996, Krugman 1997, 1998) have pointed out that globalization has had a very limited impact on wages and employment. First, France enjoyed a trade surplus throughout most of the 1990s and up to 2005. Second, although some studies (Biscourd and Kramarz 2003) have argued that French internationalized firms have lost more, or created fewer, jobs than firms that were not, or only partially, internationalized, these numbers remain relatively marginal. An INSEE study of the mid-1990s claimed that only 2 to 3 percent of French workers had been directly affected by low-wage-country competition and concluded that “300,000 French jobs had been lost to ‘globalization’ in the two decades leading up to the mid 1990s” (Smith 2004: 87). Those are small numbers compared to the 3 million unemployed workers in France in the mid and late 1990s. Similarly, between 1995 and 2001, on

average 13,545 French jobs per year were offshored (INSEE 2006: 72) whereas in 2005 only, 30,146 jobs were created by foreign direct investment (FDI) in France (IFA 2006: 26).⁹ Finally, it is worth pointing out that in France income inequality has remained fairly stable over the last thirty years and is still very far from the levels it reached in the 1930s and 1960s (Piketty 2003) (see Figure 1.5).

Figure 1.5: The Top Decile Income Share in France, 1900-1998

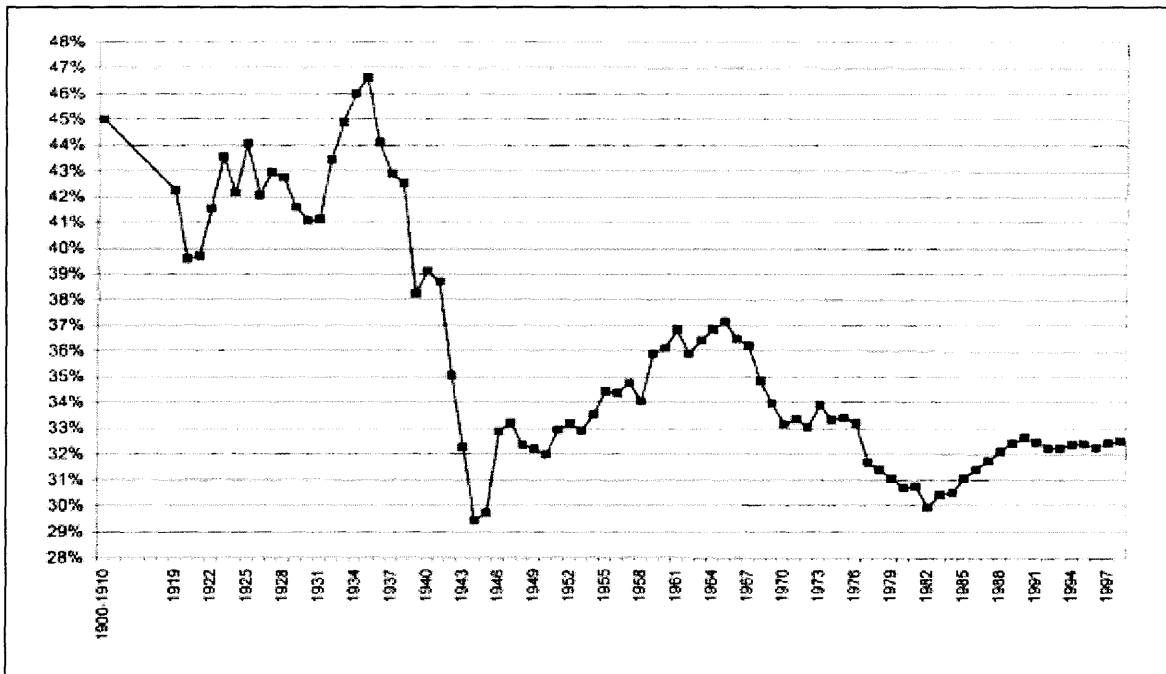

Source: Piketty (2003: 1010).

Note: The top decile income share refers to the share of the richest 10 percent of the French population in total income. So, for example, when the top decile was about 32/33 percent, in the 1990s, it meant that the average income of the top 10 percent was about 3.2/3.3 times larger than the average income of the entire population.

Another claim was that globalization was bad for labor because it undermined labor market institutions that supported workers. Nonetheless, several studies have demonstrated that increased trade and capital mobility had no substantial effect on industrial relations

⁹ When assessing the impact of FDI flows on employment, it is also worth pointing out that offshoring can indirectly create jobs by bringing about productivity gains that allow parent companies to increase their production and hire additional personnel.

systems (Golden 2000, Golden and Londregan 1998, Golden et al 1999, Scruggs and Lange 2002). As I explain in Chapter 3, the decentralization of collective bargaining in France was the result of political rather than economic factors.

Finally, the claim according to which globalization entails a loss of national autonomy policy-wise and pressures governments to cut welfare spending has been questioned by a very large body of literature (Berger 2000, Brady et al 2007, Garrett 1998, Garrett and Lange 1991, Hall and Soskice 2001, Kitschelt et al 1999, Swank 2002). Welfare reforms have been enacted in many advanced industrial economies, but it is very difficult to demonstrate that they stem from the pressures of globalization. As Duane Swank (2002: 198-200) remarks about France:

There is little in the way of evidence that a belief in the “imperatives” of international competitiveness and business location systematically drove social policy change during the tenure of Center-Right or post-1982 Socialist governments. . . . the real impacts of internationalization of markets in the French case appear to be indirect, conjunctural, and limited in effect. . . . despite intense fiscal and demographic pressures, the French welfare state in the mid- to late 1990s is hardly significantly less generous and encompassing than it was in the mid- to late 1970s. . . . In sum, while there is ample evidence to conclude that notable reforms and partial restructuring of the French welfare state have occurred, the French welfare state has not significantly converged toward the neoliberal model.

In light of the evidence, it seems that globalization is perhaps not as bad for labor as economic and structuralist perspectives assume. But even if it were, these perspectives would still have a hard time explaining why two labor organizations with relatively similar social constituencies respond differently to globalization. Or, in other words, why class location does not allow to predict positions on globalization. Albeit in 1998 blue-collar workers represented 39 percent of the CGT’s membership compared to 25 percent of the CFDT’s, low-skilled white-collar employees made up 33 percent of the membership in

both organizations (Andolfatto 2001: 67).¹⁰ The only major social difference between the two organizations—that the CGT is overwhelmingly based in the public sector whereas more than half of the CFDT’s membership is in the private sector—cannot explain either why the CGT took the path to resistance while the CFDT took the path to adaptation. The fact that the CGT is based in the public sector should actually have made it less sensitive to the issue of globalization. As Scruggs and Lange (2002: 130) point out, “insofar as most wage earners in advanced democracies work in sectors that are not directly exposed to international market forces (e.g., public services, construction, domestic transport, private utilities), the direct impact of globalization on the thinking and behavior of most workers and most employers may be quite limited.” Even in the textile and apparel industry—where the competition from emerging countries has been the fiercest for over three decades—workers’ federations of the CFDT and the CGT responded differently to globalization in spite of the fact that they are composed of roughly the same proportion of blue-collar workers.

3.2. The Institutional Perspective

Instead of assuming that globalization is bad for labor and generates resistance, the institutionalist perspective begins by looking at domestic institutions. It assumes that institutions, defined as formal and informal rules of the game and shared cognitive and normative frameworks, provide opportunities and constraints as well as material and

¹⁰ Low-skilled white-collar employees refer to what the French call “employés” and has to be distinguished from other white-collar workers such as managers, or what the French call “cadres.”

symbolic resources that shape interests and collective action and, thereby, the strategies that actors adopt (Campbell 2004, Hall and Taylor 1996, Powell and DiMaggio 1991).¹¹

Insofar as it focuses on domestic institutions, this perspective is particularly relevant for explaining why and how responses to globalization vary across countries (cf. Berger and Dore 1996, Ebbinghaus and Visser 1999, Hall and Soskice 2001, Kitschelt et al 1999, Scruggs and Lange 2002, Swank 2002, Western 1997). The presence of neo-corporatist arrangements, tri-partite institutions, centralized collective bargaining, or union-run employment funds like the Ghent system, will determine labor responses to globalization. In France, the presence of weak labor institutions, like decentralized collective bargaining, and the fact that organized labor has traditionally been excluded from the decision-making process in spite of the existence of tri-partite institutions, entail that trade unions are likely to feel threatened by globalization and oppose it through protest. Such prediction seems to fit the French labor responses of the 1970s, when the CFDT and the CGT engaged in the radical strategy, but not some of the 1990s and 2000s, when the CFDT engaged in the adaptation strategy.

Although they explain *cross*-national variation, these institutionalist accounts are less comfortable with *intra*-national variation. They implicitly hold a thin understanding of actors, in that they boil them down to empty shells reacting mechanically to the institutional environment (cf. Berger 2005: 44, Turner 2005: 389). Organized labor not only draws from the resources that the institutional context provides, but also has a legacy of its own. Institutional accounts stressing institutionalized cognitive and normative

¹¹ Some authors have tried to combine the economic and the institutionalist approaches. For example, Alt et al (1996: 695) stress that domestic political institutions matter insofar as they determine whether and how actors will act on their policy preferences. Nonetheless, they still rely on the assumption that policy preferences stem from the distribution and mobility of production factors.

frameworks offer a helpful corrective insofar as they focus on the role of “historically embedded predispositions” (Marks and Wilson 2000: 459), collective identities, and ideological traditions (Dreiling and Robinson 1998, Milner and Judkins 2004). These predispositions, identities, and traditions stem from the location of actors in the configuration of national cleavages. As I will explain in Chapter 2, organized labor is not only embedded in the class cleavage, but also in political cleavages, like the church-state cleavage and the reform-revolution cleavage (Ebbinghaus 1993, Ebbinghaus and Visser 2000).

From this standpoint, the divergent responses of the CFDT and the CGT can be explained by their respective embeddedness in different sides of these cleavages. The CGT stands on the revolution side of the reform-revolution cleavage and the state side of the church-state cleavage. In contrast, the CFDT arguably stands on the reform side of the reform-revolution cleavage and the church side of the church-state cleavage because of its Christian origins. As I will explain in chapters 5 and 6, when I will discuss the respective pathways of the CFDT and the CGT, the reform-revolution and the church-state cleavages are the two most important cleavages to impact labor responses to globalization.

Therefore, this more historical brand of institutionalism can shed some light on labor responses to globalization and account, to some extent, for their variation *within* countries. However, it suffers from an overemphasis on continuity and assumes that today’s responses to globalization are relatively similar to past and future responses. It makes predictions on grounds of past positions and practices. In contrast, I contend that today’s labor responses to globalization in France could not have been predicted by looking at the radical strategy of the 1970s. Instead of treating them as “frozen” or

“crystallized,” we need to look at the dynamic reproduction of these responses (cf. Thelen 2003) so as to account not only for variation *within countries* but also *over time*. We need to sort out what has changed from what has stayed the same (Thelen 2003: 221).

4 | THE ARGUMENT IN BRIEF

This dissertation argues that current labor responses to globalization have to be analyzed as the outcome of developmental pathways triggered by socio-economic and political-institutional changes that undermined the ability of organizations to mobilize critical resources. As I will show, these changes were not necessarily the product of globalization as such but nonetheless contributed to the way labor organizations today respond to globalization. Rather than focus on macro-economic changes or domestic institutions, I propose to take as my starting point the concrete experience of these organizations as they tried to address the problems and challenges they encountered. It is in doing so that they made decisions that added up to gradually generate a new path that led them to either the adaptation or the resistance strategy.

The main challenge that French labor organizations encountered was a structural challenge that emerged in the late 1970s and 1980s. This challenge involved the crisis of institutionalized practices and resource mobilization strategies associated with class politics, that is, a discourse, mode of collective action, and political agenda, inspired by and based on working-class criteria and interests (cf. Bartolini 2000, Sartori 1990). This crisis of class politics implied that labor organizations experienced a situation of organizational failure that became particularly obvious with the dramatic decline of their

membership and fostered internal struggles between defenders of the status quo and advocates of change. I contend that this situation brought about a critical juncture that made radical reorientations possible and led labor organizations to depart from their previous positions and practices and embark upon distinctive developmental pathways (cf. Ebbinghaus 2005, Johnson 2001, Pierson 2004).

I argue that whether a given trade union embarked upon a path leading to adaptation rather than resistance depended on three factors: (1) its organizational repertoire; (2) its organizational linkages; and (3) the logic of change and stabilization of its developmental pathway. The *organizational repertoire* or tool-kit refers to the relatively stable cultural materials to which members of a given organization can turn to define their collective identity as well as make sense of the world and engage in it (Lamont and Thévenot 2000, Swidler 1986, 2001). *Organizational linkages* are defined by their strength and breadth (Aveni 1978) and condition the access to resources and potential flexibility of an organization. Both repertoires and linkages simultaneously enable and constrain collective action.

The *logic of change and stabilization* refers to the way in which a given organization took a path rather than another as well as the way in which this path was reinforced once it had been taken. Two logics of change stand out from the comparison of the CFDT and the CGT, *conversion* and *layering*. While the former implies the redefinition of the goals, purposes, and discourse of an organization and a consequential redeployment of its resources, the latter involves gradual reforms at the margin of the organization and the adoption of new peripheral goals and strategies next to the old ones (cf. Streeck and Thelen 2005, Thelen 2003). These processes of change are constituted by two central

mechanisms: *bricolage* (recombination of resources at hand for problem-solving purposes) and *identity shift* (recasting of an organization's self-definition).

Whether an organization engages in conversion or layering depends on its organizational repertoire and linkages. The latter determine how the situation is interpreted and narrated as well as the options and room for maneuvering that organizations will have when engaging in bricolage. Insofar as this is a political process, the balance of power between defenders of the status quo and advocates of change will be a critical factor. The more defenders of the status quo are strong, the less conversion is likely and the more layering will be implemented. I claim that the CFDT engaged in a process of conversion that led it to significantly depart from its original path, whereas the CGT engaged in a process of layering that led it to gradually recast its traditional positions and practices without making substantial changes.

Finally, two logics of stabilization emerge from the comparison of the CFDT and the CGT: the *closure* or *opening* of the organizational opportunity structure (the organizational elements that facilitate or impede internal debates and challenges). Whether an organization will stabilize through closure or opening is closely intertwined with the logic of change. As I will show, the decision of the CFDT's leadership to change through conversion led to an internal countermobilization that pushed the leadership to engage in closure. The latter, in turn, had the unintended effect of bringing about a schism and renewed competition. In contrast, the CGT changed through layering and thus faced growing internal contradictions.

The second challenge that labor organizations encountered was a competitive challenge that emerged in the late 1990s with the rise of the antiglobalization movement.

Although organized labor had participated in the emergence of this movement, it soon realized that it entailed a stiffer competition for resources and control of the public debate. Labor organizations could compete by either converging with or diverging from the antiglobalization movement. The CFDT competed through divergence whereas the CGT competed through convergence. Instead of fostering a critical juncture, this competitive challenge led labor organizations to consolidate the path they had taken when they reacted to the structural challenge.

Whether labor organizations eventually responded to globalization through adaptation or resistance depends on the cumulative effect of their reactions to these two challenges.

5 | OVERVIEW OF THE DISSERTATION

In order to demonstrate the central argument, I proceed as follows. Chapter 2 introduces the theoretical framework of the dissertation. It lays out the challenges that organizations encountered and provides an analytical account of their responses. Chapter 3 examines the structural challenge that labor organizations encountered in late 1970s and 1980s in the form of a crisis of class politics. Chapter 4 presents the competitive challenge. It analyzes the rise of the antiglobalization movement in France and its impact on public debates. Chapters 5 and 6 analyze in detail the transformation and reproduction of the organizational pathways of the CFDT and the CGT. And finally, Chapter 7 concludes with a discussion of the contribution of this dissertation to the literature on institutional change and the politics of globalization.

An Organizational Approach

This chapter argues that in order to account for labor responses to globalization it is necessary to adopt an organizational approach. Adopting such an approach implies assuming that organizations are not empty shells that individuals use to realize pre-existing interests but complex structures that generate interests and identities of their own that shape the behavior of the people animating them. It entails treating organizations and their trajectories—instead of individual characteristics or institutional configurations—as the key unit of analysis. I contend that insofar as the labor organizations under scrutiny represent relatively similar social constituencies and face common socio-economic and political-institutional changes, we must look for the sources of cross-organizational variation in processes unfolding *inside* rather than *outside* organizations.

However, it does not follow that we can simply ignore the environment of organizations. Changes taking place in this environment can undermine established organizational practices and strategies and push organizations to change. The key to understanding labor responses to globalization lies in this interaction between changes taking place in the environment of organizations and processes unfolding inside them.

This chapter lays out a theoretical framework that focuses on the mechanisms and processes leading labor organizations to respond to globalization in one way rather than another. First, I present the environment in which the organizations under scrutiny operate. Second, I introduce the two challenges that these organizations have encountered since the late 1970s and explain why the first one entailed a critical juncture that made reorientations possible. Third, I discuss the struggles that took place inside these organizations as defenders of the status quo and promoters of change tried to push their organization in different directions. I go over the two factors—repertoires and linkages—and the three mechanisms—bricolage, identity shift, and shift in the organizational opportunity structure—that shaped these struggles. I then explain how different combinations of mechanisms can entail different modes of change and stabilization. Finally, I present my research method, based on process tracing.

1 | THE ENVIRONMENT OF ORGANIZATIONS

Whatever their goals, organizations must mobilize resources from their environment in order to exist and act (Fligstein 2006). According to McCarthy and Zald (1977: 1221), “the amount of activity directed toward goal accomplishment is crudely a function of the resources controlled by an organization.” Organizations need members, funding, institutional certification and access, legitimacy, etc. These resources have a cumulative effect: additional members increase the funding and the legitimacy of organizations, and thereby their access to future resources. The ability to gain access to resources is dependent on the effectiveness of the strategies implemented but also on the structure of the

organizations' environment. The more stable their environment, the more they are able to devise strategies with predictable results to mobilize resources. Resource mobilization thus becomes routinized. The more unstable and uncertain their environment, the more difficult it is to devise an effective strategy and the more intense the struggle inside the organization between defenders of the orthodoxy and proponents of innovation.

The environment of labor organizations is arguably constituted by two dimensions: a structural dimension and a demographic dimension. The structural dimension includes the socio-economic and the political-institutional contexts. The demographic dimension refers to the number and type of organizations populating a given environment. I discuss each dimension consecutively.

1.1. The Structural Dimension

In Western Europe, from 1945 to the mid 1970s the structural context benefited labor organizations. In spite of national variations, it was characterized by full employment, Fordist mass production, the institutionalization of collective bargaining, and the expansion of the Keynesian welfare state. During this period, labor organizations managed to devise relatively effective strategies for mobilizing resources that were associated with class politics. Here I do not cover the transformations that have been taking place since the late 1970s, for those lie at the core of Chapter 3, which addresses the structural challenge.

1.1.a. The Socio-Economic Context

The post-World War II era is often presented as generally positive for the working-class in advanced industrial economies. First, the consolidation of vertically integrated, Fordist mass production of standardized goods favored a homogenization of working-class interests and concentrated workers in large factories, turning the white male blue-collar worker into the archetypical industrial worker. According to Jonas Pontusson (1992: 28), Fordism favored trade unions by generating “a large intermediary group of semiskilled workers, which came to constitute the core constituency of organized labor in most countries.” Moreover, collective bargaining was generally restricted to quantifiable issues (wages, benefits, and working hours) that contributed to the homogenization of labor interests and, thereby, to their representation by unions (Pontusson 1992: 28). The new organization of industrial production thus facilitated recruitment and representation, and unions grew in all OECD countries (Ebbinghaus and Visser 2000: 59, 62).

The development of Fordist mass production came with the expansion of the Keynesian welfare state that boosted domestic demand for standardized consumer goods and, thereby, reinforced Fordism. Welfare policies also fostered a decommodification of labor that lowered competition among workers and, together with full employment, increased the bargaining power of labor organizations (Pontusson 1992: 27-28). Both Fordism and welfare state expansion benefited from trade liberalization. Up to 1973, the terms of trade supported industrial production in advanced industrial economies, as the price of primary products (especially oil) exported by developing countries remained low while a substantial portion of the standardized manufactured goods that West European countries produced were exported. This favorable situation generated a surplus that West

European governments used to improve welfare state policies and increase public investment (Keohane 1984: 21). There was a virtuous circle at work that relied upon and fostered routinized resource mobilization strategies. More generally, the apparent¹² success of Keynesian policies reinforced the belief that state intervention could favor not only workers but the economy as a whole. The policy packages advocated by labor organizations thus enjoyed a strong legitimacy.

France followed to some extent this pattern with a delay. Large firms developed but small-and-medium size firms remained significant. Although workers enjoyed full employment and the expansion of welfare policies, wage increases and, thereby, mass consumption were generalized only after the Grenelle Agreements between trade unions and the state that followed the May 1968 protests (Boyer 1984: 33). Similarly, union density—the proportion of unionized workers as a share of the total workforce—rose right after May 1968.

1.1.b. The Political-Institutional Context

The political-institutional context refers to the set of relevant institutions in which organizations operate. Institutions are formal and informal rules of the game that structure standard practices and interactions through a given set of incentives and compliance procedures. They provide opportunities and constraints as well as material and symbolic resources that shape interests and collective action. They also imply basic, shared cognitive schemas that underpin their taken-for-grantedness and feed collective identities (Campbell

¹² Some authors have questioned the causal link between Keynesian policies and the postwar boom and have stressed instead the positive effects of postwar reconstruction on growth.

2004, Hall and Taylor 1996, Powell and DiMaggio 1991, Thelen 1999). Institutions shape but do not determine collective action. They constitute a framework as well as a social space in which actors coordinate their actions but also engage in struggles. They are arenas, that is, spheres of conflict or battlefields in which some actors have more power than others (Bourdieu 1992: 72-73, 77-78, Fligstein 1991, 2001). I will thus speak of *institutional arenas* rather than just institutions.

With respect to the labor organizations under scrutiny here, the primary relevant institutional arena is the industrial relations arena.¹³ The latter refers to the rules regulating interactions between trade unions, employers, and the state. It shapes how class interests are represented in the labor market and defines the role of each party in the formulation of government economic and social policy. The post-WWII French industrial relations arena was shaped by the development of distinctive national cleavages over time (Ebbinghaus and Visser 2000: 40). Drawing upon Lipset and Rokkan (1990), Bernhard Ebbinghaus (1996: 34) identifies three major cleavages that shaped West European trade unions and labor movements—the labor-capital cleavage, the state-church cleavage, and the reform-revolution cleavage—and brought about the emergence of varieties of political unionism. The labor-capital cleavage implied the emergence of the labor movement and socialist parties; the state-church cleavage fostered the creation of Christian unions and parties; and the reform-revolution cleavage entailed a schism in the labor movement between pro-

¹³ I will show in chapters 5 and 6 that trade unions sometimes intervene in the arena of electoral politics by supporting a candidate or party in national elections. When they do so, they are constrained by the specific configuration of that arena. Nonetheless, most of the time they engage in public debates from the industrial relations arena.

Soviet and anti-Soviet labor organizations.¹⁴ According to Ebbinghaus (1996: 37), historical developments in France led to polarized pluralism, wherein trade unions are split between a reformist socialist current, a Christian-social current, and a radical-communist current. The influence of these cleavages persists today, in spite of the decline of the Church and the collapse of the USSR.

Because of these legacies and the existence of a widespread anti-union stance among French employers, labor organizations have been weaker in France than in most other West European countries. This weakness was accentuated by the way in which the state's management of the economy included technocrats and business but disregarded labor (Ross 1982: 21). As a result of this consistent organizational weakness, French trade unions have been unable to achieve substantial gains through collective bargaining and have relied instead on state legal interventionism.

For example, in 1950 the state implemented a law allowing the Ministry of Labor to extend to entire industries collective bargaining agreements signed by a given number of firms (Boyer 1984: 33). This law explains the fact that most French workers are covered by collective agreements in spite of a very low union density rate.¹⁵ In 1966, the state implemented a law granting the status of "representative organization"—that is, an organization allowed to sign collective agreements that could be extended and invited to seat on tripartite (labor, business, state) boards—to the five dominant labor confederations that had played a role in the Resistance against the Nazis (CGT, CFDT, CFTC, FO, and

¹⁴ The name of the reform-revolution cleavage can be misleading because it implicitly grants the monopoly of "revolution" to Marxist-Leninist organizations that were members of the Third International, when in fact some anticommunist leftwing organizations, such as the CFDT, were at times as or more revolutionary than Marxist-Leninist organizations insofar as they advocated more radical tactics and far-reaching social change.

¹⁵ According to Wallerstein and Western (2000: 358), in 1990 France had the second highest coverage rate among OECD countries, with 92 percent of coverage.

CGC). This law is still enforced today and contributes to the marginalization of non-affiliated workers' federations and small unions in the French industrialization relations arena. Furthermore, the extension of collective agreements entails that unions have less incentives to build a united front against employers and remain thus divided and weak. Paradoxically, a law that benefited workers undermined unions.

The French state seems to be an endless source of institutional resources for organized labor. After WWII, it instituted a hybrid form of corporatism by granting unions and employers prerogatives in the management of social policy, including seats on the board of pension and unemployment insurance funds (Lallement 2006: 54). These funds often provide unions with substantial revenues (Andolfatto and Labbé 2006b: 126). The state also pays for the training of union delegates and for work relief so that they can work part or full time for their organization (Andolfatto and Labbé 2006b: 125-26). Such reliance on state legal interventionism and resources entails that French labor organizations have always been very politicized.

1.2. The Demographic Dimension

The demographic dimension refers to the number and nature of actors competing with a given organization. Several studies (e.g., Wilson 1995, Zald and Ash 1966) have shown that the closer the contestants are to one another, the more intense the competition is likely to be because they will be aiming at the same pool of resources. In contrast, if actors have mutually exclusive goals, they will not appeal to the same contributors and, therefore, competition will decrease (Wilson 1995: 263-264).

Building on these premises, I contend that when organizations compete within an institutional arena that defines resources (e.g., vote, membership, etc.) in exclusive terms, competition is likely to be a zero-sum game: one cannot belong to two competing unions at the same time or vote simultaneously for two competing parties. It follows that the growth of a given organization will generally take place at the expense of another. Because of this potential threat, organizations often support barriers to prevent new competitors from entering the institutional arena in which they operate. For example, as I mentioned above, the industrial relations arena determines which unions are deemed legitimate to sign plant or branch agreements. Similarly, the electoral arena puts conditions on candidacies for office and on the voting threshold they need to reach to get funding and/or elected. These barriers to entry limit the number and type of organizations operating in institutional arenas and, thereby, stabilize the structure of competition (Zald and McCarthy 1980: 4).¹⁶

In contrast, if organizations compete across institutional arenas—e.g., a party competing with a union or a social movement organization (SMO)—resources will not be exclusive and there will not be a zero-sum dynamic. There is a priori no contradiction between joining and/or supporting simultaneously a party, a trade union, and a social movement organization. The absence of a zero-sum competition makes it more difficult to assess the level of threat embodied by a challenger emerging in a parallel arena and, thereby, to predict how organizations will react. I argue that competition across institutional arenas is essentially centered on the terms of the public debate and on the organizations' respective status in this debate. When organizations realize that an issue that

¹⁶ This situation has led Blyth and Katz (2005) to argue that we could witness a shift from catch-all parties to cartel parties.

was raised in other arenas draws a large support, they often pick it up and try to make it theirs because the popularity of the issue makes it a potential vector for further resources. (cf. Meguid 2005).¹⁷ In doing so, they can change the terms or shift the axis of the public debate.

In the postwar era, competition among labor organizations essentially involved the CGT, which was the dominant labor organizations in the French industrial relations arena, and the CFDT, which was developing quickly (it caught up with the CGT—in terms of membership numbers, membership share, and performance in professional elections—in the early 1990s). During this period, these two organizations intervened in the electoral politics arena but did not really compete with them. The CGT was subordinated to the political agenda of the French Communist Party (PCF) whereas the CFDT invested substantial resources in trying to form a broad non-Communist coalition with the Socialist Party (PS) and the small United Socialist Party (PSU). I discuss these relations in more detail in chapters 5 and 6.

2 | WHEN ORGANIZATIONS FAIL

Changes in the environment of organizations can generate incentives and pressures to adjust. The most common signal of the need to adjust is organizational failure, that is, when an organization no longer manages to mobilize critical resources—such as members, support, funding, and information—and ensure cooperation among its leading members

¹⁷ As students of electoral competition have shown, issue ownership (i.e., the linkage between an issue and an actor in time) plays a role in structuring the distribution of support for competing actors (Meguid 2002).

(cf. Wilson 1995: 30-31). Organizational failure often takes the form of a legitimacy crisis. Such crisis can be threefold: *internal* (when members question or challenge the leadership), *societal* (when the public questions the representativeness, agenda, and/or authority of the organization), and *institutional* (when the state refuses to recognize the organization as a valid interlocutor). A crisis of internal legitimacy involves heightened conflict between, on the one hand, the “dominant coalition” of the organization (Panebianco 1988: 37), in this case the confederal majority, and, on the other hand, dissenting or insurgent factions.¹⁸ Such a crisis undermines the sustained cooperative effort among leading members of the organization that organizational maintenance requires. A crisis of societal legitimacy entails a decrease in public support for the organization as expressed in polls, votes, and membership. Finally, an institutional crisis of legitimacy refers to a contentious episode in which the state deprives the organization of its officially representative status and no longer validates its claims.¹⁹

In the case of the CFDT and the CGT, the institutional dimension was not an issue insofar as in 1966 these two organizations had been recognized by the state as “representative organizations.” If there was a lack of institutional legitimacy, it came from the historical reluctance of French employers to engage in collective bargaining. Therefore, the organizational failure of the CFDT and the CGT in the late 1970s and 1980s crystallized essentially around the internal and societal dimensions of legitimacy as these organizations faced a growing wave of internal discontent and saw their membership decline dramatically. These two dimensions had a cumulative effect insofar as the societal

¹⁸ By “factions,” I mean an organized minority inside an organization whether this minority has an affiliated organized rank-and-file or is simply an aggregation of leaders at the top.

¹⁹ This refers to what McAdam, Tarrow, and Tilly (2001) call “de-certification.”

legitimacy crisis fostered internal debates and struggles that undermined the legitimacy of the leadership inside the CFDT and the CGT. Vice versa, the internal legitimacy crisis damaged the public image of these organizations and, thereby, contributed to the societal legitimacy crisis.

Although organizational failure stemmed from intertwined dynamics taking place both inside and outside organizations, changes in the structural environment of organizations set it off. These changes led to a structural challenge that forced labor organizations to engage in a long and difficult process of adjustment. Changes in the demographic environment of organizations led to a competitive challenge which did not have as much impact but nonetheless contributed to shaping labor responses to globalization today. I discuss the structural challenge in Chapter 3 and the competitive challenge in Chapter 4.

For now, it suffices to point out that the structural challenge refers to the socio-economic and political-institutional changes that took place in the late 1970s and 1980s and that involved a crisis of class politics. Insofar as class politics had been at the basis of the resource mobilization strategies of French labor organizations, the structural challenge fostered organizational failure. Furthermore, the structural challenge required that organizations made major adjustments because it entailed not only a change in the context of collective action but also a transformation of the very resources that organizations mobilize. The latter had to devise new strategies as well as redefine their identities, projects, and policy prescriptions. That is why the structural challenge, more than the competitive challenge, increased so much the uncertainty that labor organizations faced.

The competitive challenge refers to the rise of the antiglobalization movement in the late 1990s.²⁰ The latter competed with the CFDT and the CGT in two different ways. On the one hand, since social movement organizations active in the antiglobalization movement did not evolve in the industrial relations arena, competition partly took place across arenas and concentrated on the terms of the public debate. On the other hand, small, radical trade unions active in the antiglobalization movement competed with the CFDT and the CGT for membership and support. When competing with the antiglobalization movement, labor organizations could choose to either converge toward it or diverge from it.²¹

The core issue of the structural and the competitive challenge was the maintenance of labor organizations rather than the interests of workers. As I will show in chapters 5 and 6, when they revised their strategies and departed from their path the CFDT and the CGT were reacting primarily to threats to their organizational interests rather than to job losses or wage stagnation.²²

3 | THE POLITICS OF ORGANIZATIONAL MAINTENANCE

In the era of class politics, the resource mobilization strategies of the CFDT and the CGT seemed effective and, even though slow-moving structural processes were undermining

²⁰ There were other challengers before the antiglobalization movement, such as the so-called “new social movements” of the 1960s and 1970s. However, these movements did not focus on global economic integration and had no effect on organized labor’s positions on globalization.

²¹ This point is inspired by the literature on party responses to the rise of new challengers (e.g., Burgess and Levitsky 2003, Meguid 2002, 2005).

²² Golden (1997) makes a similar argument in her study of union responses to downsizing.

them, there was no apparent impetus to modify them. There was no incentive to innovate or transgress the bounds of what was deemed appropriate. Labor organizations were simply engaged in what it is possible to call, paraphrasing Hall and Thelen (2006: 10), a “politics of organizational stability.” The deepening of organizational failure in the late 1970s and, above all, early 1980s changed this dynamic and opened up a space for leaders and factions aspiring to advance a new agenda (cf. Polsky 2000: 466). It created a critical juncture, that is, a moment during which radical reorientations become possible (Pierson 2004: 135). Critical junctures are thus comparable to branching points or forks in trees (Ebbinghaus 2005, Johnson 2001: 254) or to what Andrew Abbott (2001) calls “turning points.”

During such critical junctures, established orientations and resource mobilization strategies are directly challenged and become an object of struggle between defenders of the status quo and advocates of change. I call these intraorganizational struggles the “politics of organizational maintenance.” As Neil Fligstein (1991: 312) remarks, “Every organization . . . must allocate its resources toward specific goals, and this usually entails conflict over how to achieve them. The actual form and strategy of any given organization, therefore, reflect how the historical resolution of these conflicts have [*sic*] been played out.”

I argue that the CFDT’s and the CGT’s efforts to maintain themselves during the critical juncture opened by organizational failure led them to depart from the path they had taken during the era of class politics and eventually respond to globalization differently from they did in the past. The new paths upon which these labor organizations embarked were generated against the backdrop of their legacies and represented an instance of what

Margaret Weir (1992) has called “bounded innovation.” The logic behind such claim is that legacies do not preclude change but channel it (Thelen 2003: 221). But we still need to account for change. Path-dependent arguments tend to suffer from two flaws: an overemphasis on reproduction and a conception of change based on a dichotomy between stability and breakdown or “settled” and “unsettled” periods (cf. Hall and Thelen 2006, Streeck and Thelen 2005, Thelen 2003). Punctuated equilibria arguments are perhaps most vulnerable to such critique.

We need to explain not only *why* but also *how* change takes place. According to Kathleen Thelen (1999, 2003), we need to look not only at the mechanisms that sustain developmental pathways but also at the logic of change that lead actors or institutional configurations along a given path rather than another. How change takes place matters for the outcome. Certain configurations are more likely than others to yield a given logic of change and different logics of change produce different effects and thereby outcomes (Thelen 2003, Pierson 2004). Furthermore, a new path may take a long time to emerge out of a critical juncture; successive and cumulative steps may be needed that rule out any pre-determined direction (Djelic and Quack 2007: 168).

In order to avoid falling into a purely descriptive account of this process, we need to identify and unpack the logic that pushed a given organization along a path rather than another (logic of change) as well as the logic that reinforced this path once it had been taken (logic of stabilization). These two logics lie at the core of the enduring effects generated by the politics of organizational maintenance.

The particular logics of change and stabilization that distinguished each path depended on: 1) a set of organizational characteristics; 2) two mechanisms of change,

namely bricolage and identity shift; and 3) stabilization through a shift in the organizational opportunity structure. Insofar as change and stabilization are contentious processes, the internal balance of power of each organization obviously mattered. However, I treat it as a pervasive rather than discrete factor.

3.1. Organizational Characteristics

Organizational characteristics are inherited from the past—particularly the founding moment and formative phase of the organization (Panebianco 1988)—and dynamically reproduced as organizations adjust to their surrounding environment. They play the role of initial conditions that limit the range of options that actors can conceive or choose (Goldstone 1998, Pierson 2004). Two such characteristics stand out: repertoires and linkages.

3.1.a. Organizational Repertoires

Organizational repertoires refer to the relatively stable cultural materials to which actors turn to define their collective identity as well as make sense of the world and engage in it (Lamont and Thévenot 2000: 8, Steinberg 1995, Swidler 1986, 2001).²³ They are the product of long-term interactions between organizations and institutions (Swidler 1995, Tilly 1995: 26) and are thus shaped by the institutional arena in which organizations operate. The cultural materials that constitute repertoires include schemas of evaluation,

²³ The concept of repertoire is similar to what Skocpol (1994: 204) has called “cultural idioms”: “Cultural idioms are drawn upon by concretely situated actors as they make sense of their activities and of themselves in relation to other actors. . . . the very definition of groups, their interests, and their relations to one another will be influenced by cultural idioms.”

habits, categories, symbols, stories, and myths, that play the role of both *lenses* to interpret social reality and *resources* to act upon this reality. Repertoires both enable and constrain collective action and limit the range of possible developmental pathways.

It follows that organizations with different repertoires will have different menus to choose from and, thereby, start from different points of departure. The more an organization's repertoire is heterogeneous, the more that organization will be able to innovate because it will have access to a wider set of potential combinations and alternatives. Inversely, a homogenous repertoire will make innovation more difficult and reduce the capacity of a given organization to cope with uncertainty or a crisis (cf. Crouch 2005: 71, Crouch and Farrell 2004) (see Figure 2.1). In this respect, the CFDT enjoyed an advantage over the CGT insofar as it had a heterogeneous repertoire whereas the CGT had a very homogeneous one. Although the concept of repertoire does not allow us to make predictions such as "if x then y ," it does permit us to predict which developments are extremely unlikely (Pierson 2004: 160-61).

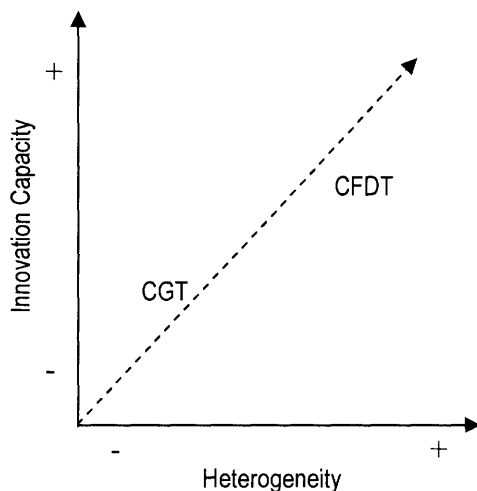

Figure 2.1: Repertoires and Innovation Capacity

3.1.b. Organizational Linkages

The concept of organizational linkages draws on the premise that organizations are embedded in interorganizational networks or organizational fields.²⁴ Organizational linkages refer to recurrent patterns between two organizations; they are the channels through which a given organization draws symbolic and material resources (ideas, information, status, legitimacy, money, members, etc.) from other organizations (Aveni 1978). As organizational repertoires, they both constrain and enable collective action and play a central role in an organization's ability to adjust to its environment and grow. As repertoires, they are also shaped by socio-political cleavages. The latter impose a vertical integration among organizations that make the development of cross-cleavage linkages very difficult (cf. Bartolini 2000). But although they are in great part inherited from the past, linkages can also be partially built as organizations choose new allies and invest in alliance building (cf. Klandermans 1997: 149).

We can distinguish *linkage strength* from *linkage breadth* (Aveni 1978).²⁵ The former refers to the intensity of the relation between two organizations, from a minimal to a maximum involvement (weak/strong linkages). The latter refers to the number of relations between a given organization and other actors (single/multiple linkages). The intensiveness and extensiveness of linkages are two indicators of an organization's access to potential additional resources. A single strong linkage can provide access to substantial resources, but so can multiple weak linkages. "Organizations wishing to increase their

²⁴ On the concept of organizational field, see Curtis and Zurcher (1973), Fligstein (1991, 1996, 2001), and Klandermans (1997).

²⁵ Aveni (1978) applies the concept of linkage to both interorganizational relations and relations between a given organization and social groups. Here, I only consider the former.

resources may either try to increase the strength of preexisting linkages or to develop additional linkages (i.e., increase linkage breadth).” (Aveni 1978: 190n2) Although they are functionally interchangeable, linkage strength and linkage breadth affect an organization’s capacity to respond to environmental changes in different ways (see Figure 2.2). While strong linkages foster stability, multiple linkages foster autonomy. Relying on multiple sources of resources implies that an organization is less dependent on a single other organization and will have other options if that organization stops supporting it or declines (Aveni 1978: 190). Multiple linkages also involve access to more varied resources and, thereby, increased flexibility.

The best scenario would thus be multiple strong linkages. However, this is not the case of the organizations under scrutiny here. The CFDT had multiple weak linkages that made it relatively autonomous whereas the CGT had an exclusive strong linkage with the French Communist Party (PCF) that placed it in a situation of relational monopoly.

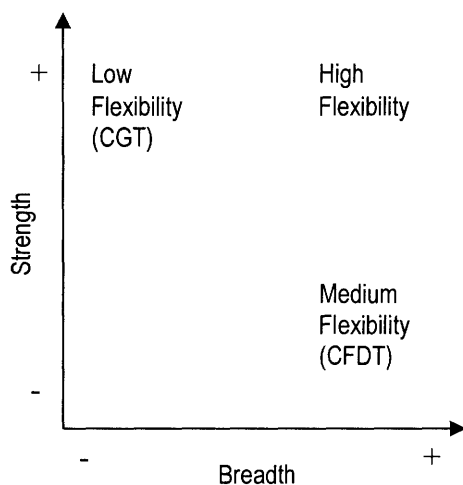

Figure 2.2: Linkages and Flexibility

3.2. The Nuts and Bolts of Change

The organizational characteristics described above are initial conditions. They are given. They shape the process of change and stabilization by limiting the range of options available to actors but do not explain it. We need to look at the specific mechanisms that relate initial conditions to the outcome, that is, organizational change leading to a transformation of labor responses to globalization. I focus on two such mechanisms: bricolage and identity shift.

3.2.a. Bricolage

The concept of bricolage refers to the way actors redefine, recombine, and rearrange the materials and resources at hand for problem-solving purposes (Campbell 2004, Lévi-Strauss 1962, Samuels 2003, Stark and Bruszt 1998). These materials and resources are “at hand” because they are institutionalized in the organizational repertoire and linkages of organizations. This condition entails that they are finite. The implicit principle of bricolage is indeed that the instrumental universe of actors is relatively closed and that, therefore, actors have to work things out with what they have (Lévi-Strauss 1962: 27).²⁶ It is this particularity that makes bricolage a mechanism of bounded change and path dependency (Campbell 2004: 70). However, in contrast to theories of “*past* dependency” (Stark and Bruszt 1998: 7), the concept of bricolage stresses creativity and agency.²⁷

²⁶ If actors were borrowing outside resources, one would have to include other mechanisms such as diffusion and translation.

²⁷ Sewell (1992: 19) defines agency as “the actor’s capacity to reinterpret and mobilize an array of resources in terms of cultural schemas other than those that initially constituted the array.”

The bricolage in which actors facing a problem or crisis engage involves the construction of a narrative of the problem and of the solution to that problem. Indeed, organizational failure does not trigger a reaction by itself. For organizational failure to become a crisis, that is, a situation requiring a decisive change, it needs to be defined as such (Hay 2001: 203, Jenson 1990: 666). It needs to be perceived, experienced, and made meaningful by the actors concerned. As John W. Kingdon (2003: 109) puts it: “There is a difference between a condition and a problem. We put up with all manner of conditions every day: bad weather, unavoidable and untreatable illness, pestilence, poverty, fanaticism. . . . Conditions become defined as problems when we come to believe that we should do something about them.”

Actors respond not so much to the situation itself as to its narrative construction (cf. Bruner 1991, Hay 2001, Patterson and Monroe 1998, Steinmetz 1992).²⁸ The narrative inserts the problem in a plot and a causal chain of events unfolding over time and invested with moral meaning (Hay 2001, Poletta 1998: 140, Stone 1989: 282-83). Narratives begin as interpretations of a problem but immediately their plot opens the way to certain solutions rather than others. Insofar as situations and problems have no inherent properties, there can be several competing narratives that describe harms and difficulties in different ways and attribute blame to different actors and/or phenomena. They can either question or justify the status quo and need not be accurate to produce effects. Their “success” stems not from their degree of accuracy or sophistication but from their ability to encompass a large number of symptoms while clearly allocating blame (Hay 2001: 204) and appealing

²⁸ My point is not that environmental changes need to be acknowledged by organizations in order to have an impact. Many changes that go unnoticed or unacknowledged affect organizations. My point is simply that we cannot explain how these changes affect the behavior of organizations without looking at the way they are interpreted and narrated.

to the identity and interests of the actors whose support and cooperation are needed (Fligstein 2001: 113). Successful narratives always involve wide alliances and a shift in the narrated attribution of responsibility can entail a restructuring of these alliances (Stone 1989: 298).

3.2.b. Identity Shift

This mechanism refers to the recasting of an organization's self-definition. It supposes the "emergence of new collective answers to the questions 'Who are you?' 'Who are we?' and 'Who are they?'" (Tilly and Tarrow 2007: 216). Identity shift is itself constituted by several other mechanisms.²⁹ Two of these apply to the cases of the CFDT and the CGT: *boundary formation* and *boundary de-activation*. While the former implies the "creation of a new us-them distinction between two political actors," the latter refers to the decrease "in the salience of the us-them distinction separating two political actors" (Tilly and Tarrow 2007: 215).³⁰

The boundaries that form collective identities can be drawn not only between organizations but also within them. For example, an internal identity shift can imply either the formation a new category of members (boundary formation) or the acceptance of identities that were formerly excluded (boundary de-activation). Even if the shift takes place within the organization, it can affect interorganizational relations by either making new alliances possible or undermining them.

²⁹ According to Tilly and Tarrow (2007: 214), "The distinction between mechanisms and processes . . . depends on our level of observation. We can always look inside any particular mechanism and find smaller-scale mechanisms at work."

³⁰ See also Ansell (2001: 19).

3.3. The Nuts and Bolts of Stabilization

Paths are paths by virtue of having a certain inertial quality (Abbott 2001: 248). Consequently, once change was set in motion, the respective new paths of the CFDT and the CGT needed to be stabilized and reproduced to qualify as paths. This stabilization was generated by a *shift in the organizational opportunity structure*: closure in the case of the CFDT and opening in the case of the CGT.

By “organizational opportunity structure,” I simply mean the organizational elements that enhance or inhibit debate and the prospects of challengers inside an organization.³¹ These elements include (1) the tolerance or intolerance of the executive leadership of the organization vis-à-vis dissenting perspectives, (2) the possibility or difficulty of access to the decision-making process, (3) the cohesion or division of the dominant coalition of the organization, and (4) the presence or absence of external interferences due to strong linkages or tight interorganizational relations. These elements vary along a continuum and are not stable or frozen. It is precisely their shift that stabilized the process of path departure of the CFDT and the CGT by either creating or eliminating informal veto points. The closure of the CFDT’s organizational opportunity structure brought about the marginalization of dissenting factions, thereby ensuring that the new path upon which the CFDT had embarked would not be questioned. In contrast, the opening of the CGT made it harder for defenders of the status quo to control their organization and push for a return to the previous resource mobilization strategy.

³¹ The concept of organizational opportunity structure is inspired by the political process model approach in social movement theory and its central concept of political opportunity structure (see Meyer 2004, Tarrow 1996, 1998, Tilly 1978).

3.4. Two Organizational Pathways

To sum up: the combination of the above initial conditions and mechanisms of change and stabilization yielded two different organizational pathways leading to two different responses to globalization today (see Figure 2.3). The logic of change of the CFDT was characterized by *conversion*, that is, the redefinition of goals, purposes, and discourse of an organization and a consequential redeployment of its resources (Streeck and Thelen 2005: 26, Thelen 2003: 226). In contrast, the logic of change of the CGT implied first *drift*—i.e., incremental change due to a gap between the organization and its shifting surrounding environment (Streeck and Thelen 2005: 25).—and then, more importantly, *layering*—i.e., the partial renegotiation of some elements of an organization while leaving others intact, thereby combining elements of lock-in and innovation (Thelen 2003: 225-26). Then, both pathways stabilized through a different shift in the organizational opportunity structure: closure in the case of the CFDT and opening in the case of the CGT.

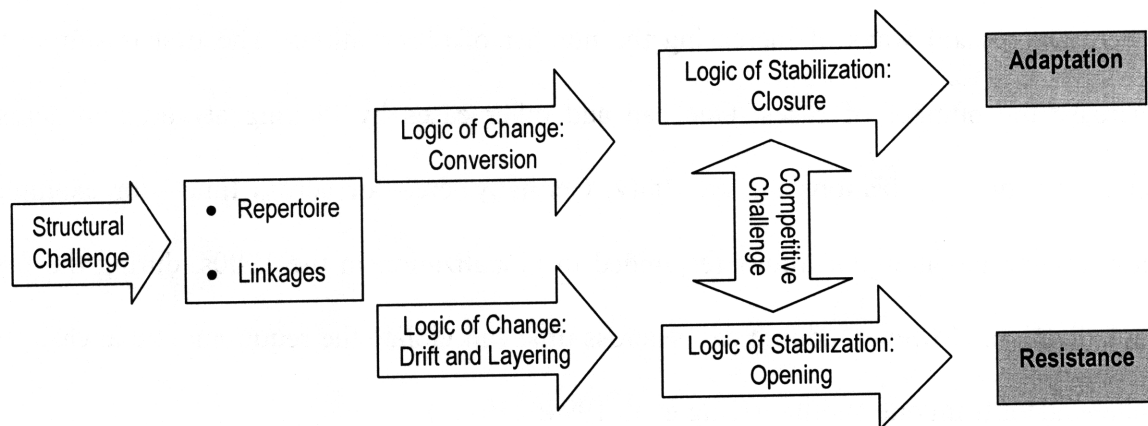

Figure 2.3: The Paths to Adaptation and Resistance

4 | RESEARCH METHOD

This dissertation compares two French labor organizations over time to account for political responses to globalization. It thus faces the obvious limits of all small-N studies—very few observations and a strong likelihood of omitting factors—that make it very difficult to formulate generalizations relevant for other cases.

In order to address this problem, we need first to clearly distinguish *cases* from *observations*. As Peter Hall (2003: 396) puts it,

A sharp distinction must be drawn between the concept of a *case* understood as a single unit of analysis where the outcome being investigated is unit-level variation and the concept of an *observation* understood as a piece of data drawn from that unit and pertinent to the theories being examined. A single unit may provide only one observation on the principal outcome of interest, but it can yield a diverse array of other observations pertinent to the testing of a theory, including ones bearing on the causal processes specified by the theory.

King et al. (1994: 52) make a similar argument and explain that they “reserve the commonly used *n* to refer only to the number of observations and not to the number of cases.” Thus, a small-N study is one that relies not a few cases but on a few observations. There are several ways of increasing the number of observations. The first is simply to increase the number of cases. One can add other cases by looking at variation across space—labor organizations in, say, Italy, Germany, etc.—or across time—for example, how French labor organizations responded to globalization in the 1900s, during the first globalization. However, adding cases across time can violate the requirement that cases be independent from one another (King et al. 1994: 219-22).

Another option to increase the number of observations is to adopt a process-tracing method. According to two of its most enthusiastic advocates, this method “attempts to identify the intervening causal process—the causal chain and causal mechanisms—between an independent variable (or variables) and the outcome of the dependent variable.” (George and Bennett 2005: 206) It involves tracing how initial conditions translate into outcomes and unpacking this process into a series of steps or intervening variables, such as interpretations and decisions within sequences of events. So instead of independent variable 1 bringing about dependent variable 2, we would have $1 \rightarrow 1.1 \rightarrow 1.2 \rightarrow 1.3 \rightarrow 1.4 \dots \rightarrow 2$ (Chandra 2006).

Assuming that the new observations yield evidence consistent with the overall argument, the process-tracing method can substantially improve the validity and explanatory power of causal theories by enabling them to account not only for a given outcome but also for the process through which it comes about. Thus, for King et al. (1994: 227), “By providing more observations relevant to the implications of a theory, such a method can help overcome the dilemmas of small-*n* research and enable investigators and their readers to increase their confidence in the findings of social science.”

By focusing on causal paths and mechanisms, the process-tracing method can also allow us to produce potential generalizations across cases. These generalizations will not be so much about outcomes—e.g., specific domestic political responses to changes in the international economy, etc.—as about the mechanisms linking the independent variable to the dependent variable (Chandra 2006). According to Kanchan Chandra (2006), “We should evaluate the quality of such generalizations, not by testing to see if the entire chain of mechanisms linking the cause and the outcome in one country [or case] is the *same* in

others, but by seeing how *far* the chain of mechanisms in a new country [or case] coincides with that of the first before it diverges.” The point of divergence between the causal paths of the cases being compared will be the starting point of a search for new relevant mechanisms. The comparison of four causal paths upon which this dissertation focuses will not allow me to predict how other leftwing and labor organizations in the world will respond to globalization, but it will narrow the field of inquiry for future research and pinpoint key issues.

In order to trace the causal paths of the four organizations I selected, I rely on almost one hundred semi-structured, open-ended interviews with national and local leaders of each organization that I conducted in France between 2001 and 2003. I also consulted secondary sources and the archives of these organizations to trace their interpretation of the structural and competitive challenges as well as their policy positions, decisions, and internal struggles, since the early 1970s. I focused especially on official statements, congresses, and programs, but also looked at their internal bulletins and at some studies carried by their affiliated think tanks or research units. Finally, I used surveys and government data on public opinion, elections, union density, and, more generally, the economy, to describe the context and situations these organizations have been facing for the last thirty years.

The Structural Challenge: The Crisis of Class Politics

During the thirty years that followed World War II—that is, during the “*trente glorieuses*” and the so-called “golden age” of capitalism characterized by full employment, wage growth, expanding mass consumption, and improving social protections—French labor organizations relied on a pattern of resource mobilization associated with class politics. Broadly speaking, they stressed class identities, focused on large industrial manufacturing plants for recruiting members, and advocated public policies, such as nationalizations, aimed at realizing working-class interests and bringing France closer to socialism.

However, in the 1970s a combination of socio-economic and political-institutional factors transformed the environment in which labor organizations had been evolving for several decades. This structural challenge undermined the maintenance of labor organizations and the viability of class politics. It forced labor organizations to revise their positions and resource mobilization strategies and, thereby, depart from their previous path. It entailed a critical juncture that produced distinct legacies.

This chapter will first briefly define class politics and identify a set of indicators to assess its evolution in France. Second, it will lay out the main features of the crisis of class

politics and focus on the indicator most relevant to trade unions: unionization or union density. And third, it will review different accounts of the decline of union density and show that even though globalization may have played a role in this process, institutional factors mattered.

1 | DEFINING CLASS POLITICS

Class politics refers to a discourse, mode of collective action, and political agenda, inspired by and based on working-class or labor criteria and interests. The latter are not objectively given and waiting to be used, however. They are constructed and defined by collective actors as they engage in class politics. As Giovanni Sartori (1990: 169) put it, “it is not the ‘objective’ class (class conditions) that creates the party, but the party that creates the ‘subjective’ class (class consciousness). . . . The party is not a ‘consequence’ of class. Rather, and before, it is the class that receives its identity from the party.” Put briefly, class-based organizations are the supply-side of class politics.

Class politics stems from the institutionalization of the class cleavage. As one of the most important cleavages that shaped European party systems (cf. Lipset and Rokkan 1990), the class cleavage includes: (1) a *structural* dimension, related to the social stratification produced by industrialization and capitalism, that sets the conditions for group distinctiveness; (2) a *cultural* dimension that provides a sense of collective identity and a narrative of class relations; and (3) an *organizational* dimension that refers to the organizations that define class identities and interests and act in their name, thereby institutionalizing the class cleavage and giving it a relative autonomy vis-à-vis the social

structure (Bartolini 2000: 16-24).³² Insofar as these three dimensions are intertwined and mutually reinforcing, they tend to change together—even if according to different dynamics and paces—rather than separately. A change in one dimension can affect the entire configuration and potentially entail a transformation of class politics.

I propose to assess class politics in France through three sets of indicators: class consciousness, organizational capacity, and political agendas and tactics. *Class consciousness* refers to the sense of belonging to a given social class, here the working class, and can be determined primarily through qualitative surveys. *Organizational capacity* includes electoral results and membership levels. It measures the ability of an organization to mobilize a given constituency. Finally, *political agendas and tactics* indicate the extent to which organizations articulate their demands in terms of class antagonisms and pursue them through a direct confrontation with capital, according to a logic of class struggle. I will not discuss each indicator in-depth, for they are—particularly the organizational capacity and political agendas and tactics—at the core of chapters 5 and 6. I will simply trace their evolution in broad terms so as to show that class politics was indeed in crisis.

2 | THE CRISIS OF CLASS POLITICS IN FRANCE

Before tracking the crisis of class politics, a note of caution is necessary. Scholars participating in debates about the crisis of class politics, Fordism, or embedded liberalism,

³² Although he adopts a different perspective, Michael Hechter (2004: 403) uses relatively similar criteria: “class politics can be seen to rest on a trinity of preconditions: the impermeability of class boundaries, the strength of class organizational capacity, and the salience of class consciousness.”

often seem to suggest that the previous era was better. The working class was allegedly more homogeneous, united, and stronger; capital could not do as it pleased and was forced to guarantee basic labor conditions and good wages; etc. However, the fact that labor organizations could rely on class politics to mobilize critical resources did not imply that they had it easy. As Beverly Silver (2003: 6) remarks: “There is some irony in the fact that early-twentieth-century observers of the transformations associated with Fordism were certain that these changes spelled the death of labor movements. . . . It was only post facto—with the success of mass production unionization—that Fordism came to be seen as inherently labor strengthening rather inherently labor weakening.”

In France, even though labor organizations emerged out of WWII with a renewed legitimacy because of their role in the Resistance against the Nazis, they still faced a harsh environment: although work councils and a legal framework for labor relations were established right after WWII, trade unions secured legal recognition at the plant level only in 1968 while collective bargaining began to develop only in the 1970s; communist trade unionists of the CGT suffered from a targeted repression in the workplace involving administrative sanctions or layoffs; in the early 1950s, the electoral system was reformed so as to minimize the number of seats that the French Communist Party (PCF) could gain thanks to its popular support. If on the one hand, in the 1950s the PCF was one of the strongest communist parties of Western Europe, getting around 25 percent of the vote in national elections, on the other hand, the French labor movement was one of the weakest in Europe in terms of density: with a union density rate—percentage of unionized workers as a share of the total workforce—slightly above 25 percent in 1950 (like the United States), it lagged far behind Belgium, Germany, Italy, the Netherlands, Switzerland, and the United

Kingdom, which all had a rate of about 40 percent, not to mention Austria, Denmark, Norway, and Sweden, which had a rate of about 60 percent (Western 1997: 22-23).

Similarly, when some authors ask today whether class can *still* unite (cf. Van Gyes et al 2001), they are suggesting that it did so in the past. Nonetheless, according to Bert Klandermands (2001: 326-27), class never did unite because it was “too inclusive a category to spontaneously generate high levels of identification.” Even in the pre-WWII era and the 1950s, the French working class was not a homogeneous whole but a composite of a wide range of varieties of workers (Maurice and Sellier 1979: 322). It was organizational work that gave workers a sense of cohesion. However, it was also organizational dynamics that fostered the fragmentation of the French labor movement into a series of competing trade unions, thereby making the emergence of a united front against employers very difficult. In this competition, some organizations declined while others rose.

Having said all that and bearing in mind that class politics is not a homogeneous whole, it is possible to claim that the thirty years that followed WWII constituted a distinctive period insofar as several indicators of class politics, particularly those related to organizational capacity, were relatively stable or at least declining slowly. Class politics might have been eroding but not losing its grip over French domestic politics. It is only in the late 1970s that the previous pattern began to change significantly and that class politics entered a crisis.

In a major review of public opinion surveys on class identification since the 1960s, Michelat and Simon (2004: 142) remark that class belonging³³ dropped from 61 percent in

³³ Class belonging is measured by the rate of positive answers to the question “Do you have the impression of belonging to a social class?” without specifying a particular class.

1966 to 53 percent in 2002. The decline intensified in the early 1980s. More significantly, identification to the working class dropped from 23 to 14 percent in the same period. This shift in subjective identification, or in class consciousness, did not simply reflect changes in social stratification (i.e., working-class affiliation declines because there are, proportionally, less blue-collar workers today than in the 1960s). Even among blue-collar workers, working-class identification dropped: in 1966, one out of two objectively “hard-core working-class individuals” (*très ouvrier*), defined by the number of their working-class attributes (manual job, working-class family background, etc.), identified to the working class, compared to one out of four in 1993 and one out of five in 2001 (Michelat and Simon 2004: 145). In other words, working-class affiliation among blue-collar workers dropped from 50 percent in 1966 to 20 percent in 2001.

Some authors (e.g., Hechter 2004: 410) also treat class voting—i.e., the relationship between one’s class position and one’s electoral support for leftwing parties³⁴—as an indicator of class consciousness. Although this alleged relationship between class consciousness and leftwing voting is questionable,³⁵ class voting is an indicator of the enthusiasm of the working class for class politics. Several studies have shown that class voting in OECD countries has declined since the late 1970s. Although there is a big debate about the extent, nature and meaning of this decline (see Clark and Lipset 1991, 2001,

³⁴ Some authors (see, for example, various chapters in Evans 1999) define class voting as the relationship between one’s class position and one’s electoral behavior, regardless of the party one supports. For example, according to this definition, the fact that a substantial share of working-class voters does *not* vote is an indicator of the persistence of class voting. However, insofar as I am interested in class politics as an expression of the class cleavage, I will not use this definition.

³⁵ Sartori (1990: 166) remarks that class voting is not a reliable indicator of class consciousness since it “reflects a very discontinuous and superficial layer of behavior.” Moreover, assuming a relationship between class consciousness and leftwing voting implies that one believes that a leftwing political agenda is the best way to realize the interests of the working class. It also narrows one’s social identity and motives driving voting behavior to economic class interests.

Evans 1999, Goldthorpe 2002, van der Waal et al 2007), the fact is that French socialist and communist parties no longer have the support of a substantial share of the working-class vote. In 1981, more than 60 percent of workers voted for the left; in 2002, it was less than 40 percent (Balme 2006: 268). In the 2002 presidential election, the far-right candidate Jean-Marie Le Pen, president of the National Front (FN), got 26 percent of the working-class vote, compared to 12 percent for the socialist candidate, Lionel Jospin, 10 percent for the far-left Trotskyite candidate Arlette Laguiller, and 5 percent for the communist candidate, Robert Hue (Balme 2006: 267). Albeit put together these three leftwing candidates got 27 percent of the working-class vote, the FN is today France's leading working-class party in electoral terms. It does not follow, however, that one's class location no longer shapes one's electoral behavior. As John Goldthorpe (2002: 18) points out:

Class dealignment—a reduction of the level of class voting—has to be distinguished from class *realignment*—a change in the pattern of class voting. Thus, even if some long-established class-party alliances are now in evident decay . . . this need not imply that, overall, the level of class voting is being reduced. New linkages between class and political partisanship may be replacing the old.

What we have been witnessing in France since the early 1980s seems to be an instance of class realignment, favoring far-right anti-system parties at the expense of the French Communist Party (PCF), rather than one of class dealignment. Moreover, the rise of the FN in presidential elections almost mirrors the decline of the PCF (see Figure 3.1).

Figure 3.1: The Electoral Performance of the PCF and the FN in Presidential Elections

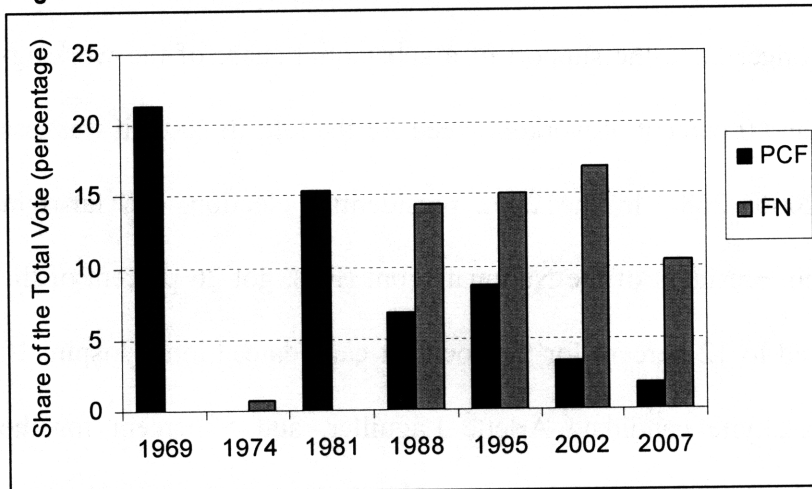

Source: CEVIPOF.

Note: Results refer to the first ballot. Presidential elections began with the Fifth Republic, in 1958, and the PCF had a candidate running for president for the first time in 1969; in 1974, the PCF had an electoral agreement with the Socialist Party and, therefore, supported the socialist candidate, François Mitterrand; this agreement fell apart in 1978 and since then, the PCF has had a candidate in all presidential elections. The FN was founded in 1972 by Jean-Marie Le Pen, whom ran for the first time in 1974 and has been the candidate of the FN in all presidential elections since then.

The crisis of class politics also became manifest in the declining membership level of working-class organizations. Union density—“the number of union members expressed as a percentage of the number of people who could potentially be union members” (Western 1997: 15)—dropped dramatically in the late 1970s after having been relatively stable for more than two decades. It went from 24.1 percent in 1955, to 19.5 percent in 1965, 22.5 percent in 1975, 13.9 percent in 1985, and 9.9 percent in 1995 (Visser 2000: 270-71). This fall was among the steepest in OECD countries (see Figure 3.2). If, as Bruce Western (1997: 15) has argued, “unionization expresses the salience of class division as a principle of collective action,” then one is inclined to conclude that collective action in

France is less and less organized along class lines. Social classes still exist, but class politics is in crisis.³⁶

Figure 3.2: Net Union Density Rates in OECD Countries

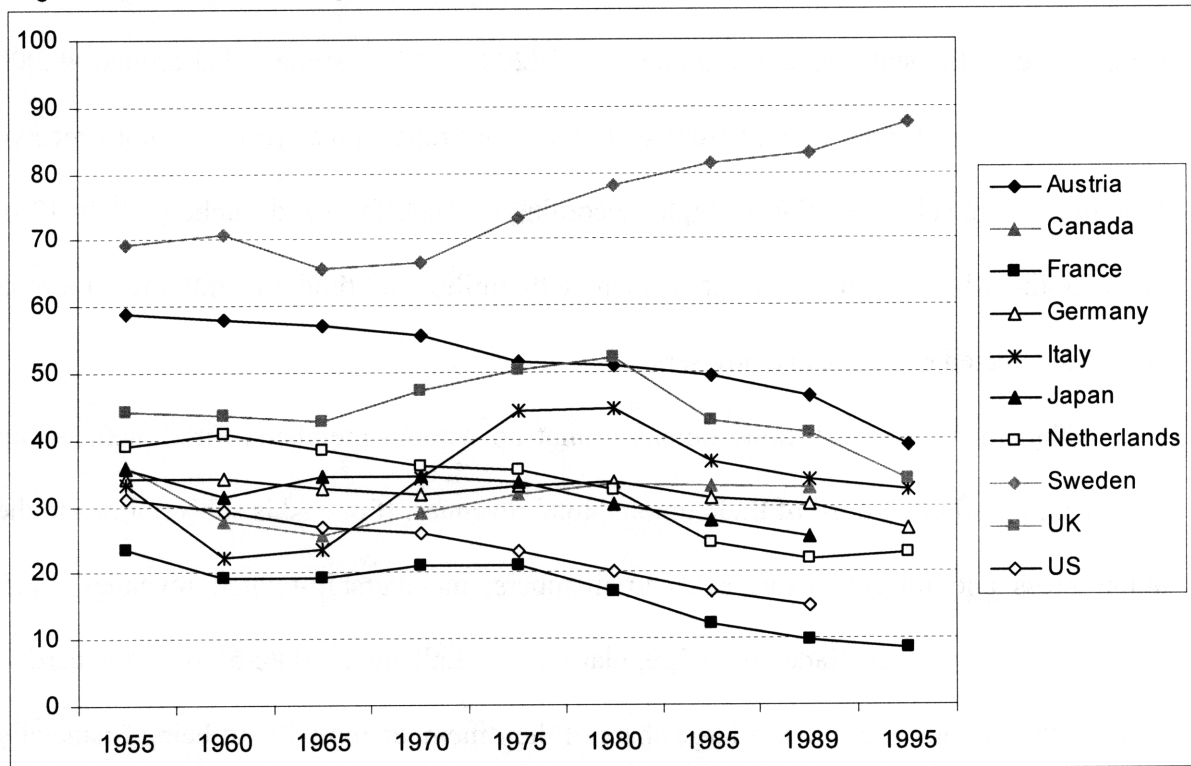

Sources: Golden, Wallerstein, and Lange (1999: 200); Scruggs and Lange (2002: 134); and Visser (2000).

At first glance, membership decline is not necessarily a big problem for French trade unions. After WWII, the French state, inspired by ideas of joint management (*paritarisme*) akin to corporatism, granted unions and employers prerogatives in the management of social policy, including seats on the board of pension and unemployment insurance funds such as UNEDIC (National Union for Employment in Industry and Trade). According to Andolfatto and Labbé (2006b: 126), these funds and other co-managed

³⁶ Louis Chauvel (2001) stresses the distinction between the real collapse of class consciousness and class identities, on the one hand, and the persistence of objective social classes, on the other.

institutions often pay substantial amounts of money—sometimes higher than the total of all annual union dues—to the organizations seated on their board. Another significant amount of funding derives from the relief from regular work duty from which many trade union members benefit. This policy allows them to work part or full time for their organization at the expense of the state. Andolfatto and Labbé (2006b: 125) estimate that around 40,000 union members in France benefit from such paid work relief. Finally, trade unions receive generous public subsidies. For example, according to Andolfatto and Labbé (2006b: 126), in 2005 the Ministry of Labor gave them €29 million to fund the training of union delegates, elected officials, and advisers.

Nonetheless, French trade unions cannot do without members. First, membership dues represent about a third of trade unions' total revenues. If one adds subscriptions to the union press and miscellaneous sales to members, membership-related revenues reach almost 40 percent of the trade unions' regular budget (Lallement 2006: 61-62). It is hard to imagine that unions could lose a large share of their membership without being financially destabilized. Second, a strong membership entails legitimacy. As unions are increasingly accused of being bureaucratic empty shells (cf. Andolfatto and Labbé 2006b) and their legal representativity—and thereby capacity to sign collective agreements—is being debated, they need to show that workers stand by them not only by voting for them in professional elections but also by joining their ranks. This membership imperative is crucial whether unions want to engage in industrial conflict with employers and the state, as they regularly did until the early 1980s, or negotiate collective agreements at the firm and industry level, as they have increasingly been doing since the early 1980s (cf. Wallerstein and Western 2000: 364).

Finally, the evolution of labor and leftwing political agendas and tactics since the 1970s also indicates that class politics is no longer the dominant strategy to make claims and pursue organizational objectives. As it is well known (cf. Hall 1986, Hoffmann et al 1987, Sassoon 1996), the turning point of the French left's political agenda was the change of President Mitterrand's economic policy in 1983. The latter went from an ambitious plan to build socialism in one country through nationalizations to an austerity policy that eventually led to the approval of the market economy and comprehensive privatizations of public sector firms. Class struggle was replaced with modernization. Similarly, as I will show in chapters 5 and 6, trade unions revised their positions and strategies in such way that they downplayed or abandoned references to class struggle and socialism. A quick search in *Le Monde* electronic database clearly shows the extent to which socialism has receded from the front stage of public debates (Figure 3.3).

Figure 3.3: Articles Referring to "Socialism" in *Le Monde*



Source: *Le Monde*, electronic archives.

Note: The rise of articles in 1989 and 1990 is probably due to the fall of the Berlin Wall. However, from 1994 on, the trend remained fairly stable and was twice as low as the numbers in 1987 and 1988.

In terms of tactics, the biggest shift has been the decline of trade union strikes and the concomitant rise of collective bargaining (see Figure 3.4). Strikes were emblematic of industrial conflict in France. Because of the particular configuration of industrial relations in France, they were one of the main labor tactics for influencing the political process and obtaining material gains. They were defined, experienced, and represented in terms of class struggle (Lallement 2006: 53). They had a strong emotional and moral dimension and directly targeted specific employers and government officials, thereby personalizing injustices and class conflict; they were thus congruent with the charismatic character of French trade unions (Maurice and Sellier 1979: 327). Strikes can also foster organizational maintenance by feeding militancy, expanding union membership, and rallying workers behind a collective project (Wallerstein and Western 2000: 360, Western 1997: 178).

Figure 3.4: Strikes, 1975-2005 (number of individual days not labored [JINT] because of a strike in a firm)

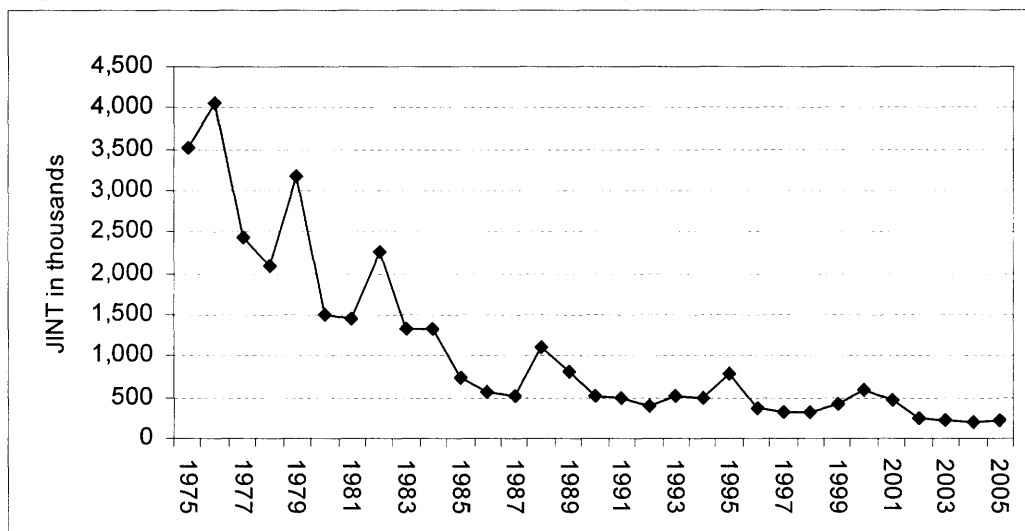

Source: DARES, French Government.

Note: For the 1975-1995 period, the available data reflect strikes in all sectors, including public transportation (i.e., SNCF, RATP, Air France). After 1995, the data no longer include public transportation, a change that can sometimes affect the curb insofar as many strikes take place in that sector.

While strikes declined, collective bargaining rose consistently after the Auroux Laws, establishing compulsory bargaining over wages and working conditions at the firm level, were implemented in 1982. The number of local agreements reached through collective bargaining went from about 5,000 a year in 1983 to almost 15,000 a year in 2003 (Lallement 2006: 58).³⁷

The convergence of all these indicators—class self-identification, class voting, union density, political agendas, industrial conflict, and collective bargaining—shows that, from the early 1980s on, class politics was no longer an efficient resource mobilization strategy. As I will explain below, this crisis of class politics was not a product of globalization. Insofar as this dissertation looks at labor responses to globalization, I will focus on the decline of union density as a key indicator of the crisis of class politics.

3 | UNDERSTANDING UNION DECLINE

There are three sets of factors to consider when explaining union decline: cyclical, structural, and institutional factors (Ebbinghaus and Visser 1999). I will review each set in turn and discuss, when relevant, whether it is related to globalization. In line with recent research (Ebbinghaus and Visser 1999, Scruggs and Lange 2002, Western 1997), my main argument will be that the effects of cyclical and structural factors are conditioned by institutional factors. Consequently, globalization alone cannot explain union decline.

³⁷ There was a huge increase in 1999, 2000, and 2001, reaching 35,000 local agreements per year, when unions and firms negotiated the implementation of the 35-hour week. However, by 2002 the number of agreements per year had begun to decrease substantially and in 2003 it returned to the trend it was following before the 35-hour-week law.

3.1. Cyclical Factors

This set of factors refers to the business and the political cycles. The former includes unemployment whereas the latter includes the electoral success of pro-labor parties and the economic policies that are implemented.

3.1.a. The Business Cycle

Unemployment can affect union density by raising the cost and lowering the benefits of union membership: on the one hand, unions have a harder time delivering incentives as bargaining with employers becomes tougher and, on the other hand, employees are less inclined to demonstrate solidarity because they are worried about losing their job (Ebbinghaus and Visser 1999: 139). Moreover, unemployed union members often experience a difficult and uncertain economic situation after being laid-off and may decide, as a result, to stop paying their membership dues, thereby contributing to decreasing the financial resources that unions need to recruit members.

In France, the unemployment rate rose rapidly in the late 1970s and early 1980s, precisely when union density began to fall. However, several studies have shown that unemployment is a weak predictor of union growth and decline (Ebbinghaus and Visser 1999: 139). The unemployment rate increased, in different degrees, in all OECD countries in that same period but changes in the union density rate varied across countries. As Figures 3.5 and 3.6 illustrate, unemployment increase and union density drop seem to be correlated in France but not in other countries. The fact that France stands out suggests that other factors than unemployment alone are at work.

Figure 3.5: Correlation Between Unemployment and Union Density in France

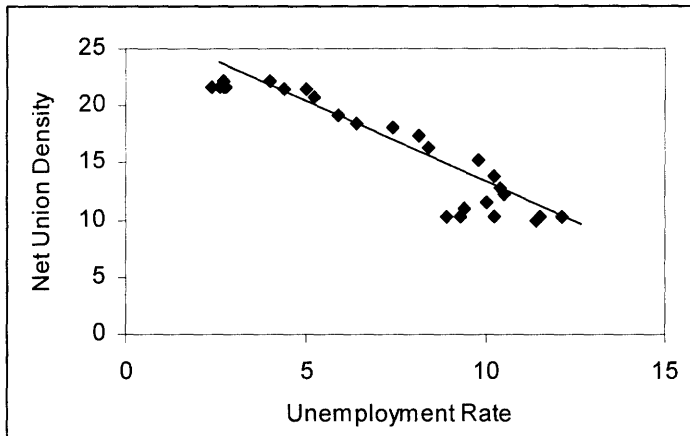

Source: ILO.

Note: The figure shows all annual values from 1970 to 1995. The sloping line indicates the trends of the correlation between density and unemployment.

Figure 3.6: Correlation Between Unemployment and Union Density in Six OECD Countries

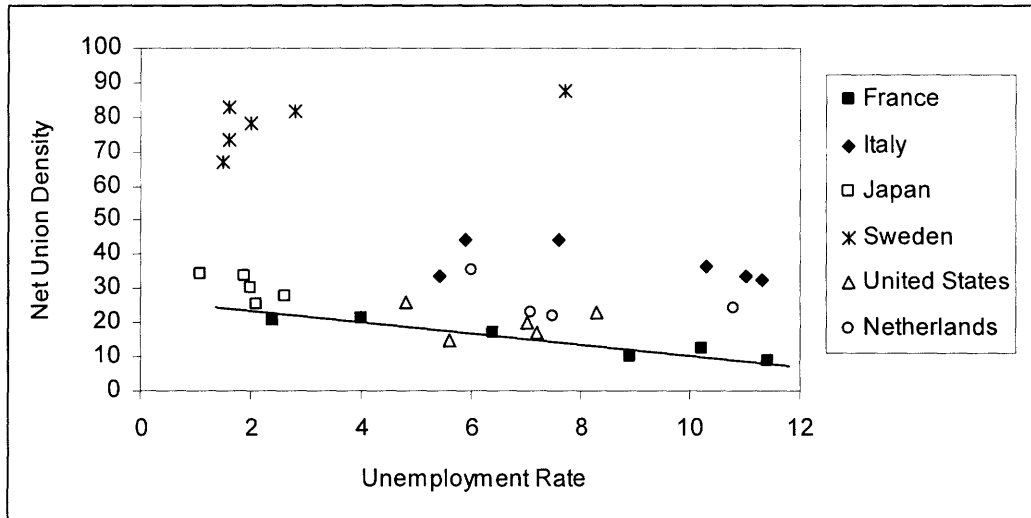

Sources: ILO; Golden, Wallerstein, and Lange (1999: 200); Scruggs and Lange (2002: 134); and Visser (2000).

Note: The values posted are for 1970, 1975, 1980, 1985, 1990, and 1995. For "1990," the Net Union Density values are actually based on 1989 data. For the US and Japan, the 1995 data are missing. The sloping line indicates the trends of the correlation between density and unemployment in the French case.

3.1.b. The Political Cycle

The electoral success of pro-labor parties can foster union density by implementing Keynesian economic policies and making the political economy more favorable to trade unions. However, in the French case the reverse seem to have been true. The electoral

victory of the left in 1981 did not stop the decline of union density that had begun in the late 1970s. Some policies that the left implemented before and after President Mitterrand's policy U-turn in 1983 seem to have contributed to union decline. These policies included not only austerity measures targeted at boosting supply but also institutional reforms that had been designed to further workers' rights and interests.³⁸ The right subsequently won a majority of seats in the National Assembly and formed a government from 1986 to 1988 and then 1993 to 1997, but these political changes did not seem to substantially affect union density. The latter continued to decline throughout the 1980s and early 1990s to finally stabilize in the mid 1990s, regardless of whom was in power.

Furthermore, the close relation between unions and parties undermined union density even before Mitterrand's 1981 victory. Some studies (Labbé et al 1990, Andolfatto and Labbé 2007) have shown that the politicization of French unions and their participation in electoral coalitions, like the socialist-communist Common Program in the 1970s, led a substantial number of members to stop paying their dues and quit unions. On the other hand, however, this politicization did not prevent union density from increasing or remaining relatively stable until 1977.

3.2. Structural Factors

This set of factors refers to long-term changes in the economy, society, and politics. Structural factors having a negative impact on union density include: "changing class structures, new modes of production, flexible labour markets, or a spread of individualist

³⁸ I will discuss these reforms in section 3.3 of this chapter.

social values” (Ebbinghaus and Visser 1999: 136). I will leave aside claims about a culture shift in advanced industrial economies (cf. Inglehart 1997) and focus instead on changes in the organization of production, labor markets, and capital mobility.

3.2.a. The Reorganization of Production

The rise of trade unions is often associated with the golden age of Fordist firms, that is, large vertically integrated firms in which a large number of male blue-collar workers performed similar tasks in a concentrated geographical space. The breakdown of these firms and the reorganization of production along fragmented and decentralized networks of small-and-medium size firms concentrating on different functions of the value chain (product definition, design, manufacturing, distribution, etc.) and relying on outsourcing, fostered the development of a temporary, flexible, and diverse workforce that hindered the recruitment efforts of unions (Western 1997: 177-78). This process of fragmentation and decentralization also made communication and information gathering more difficult for unions.

However, some authors have questioned this alleged correlation between, on the one hand, new patterns of production and, on the other, a weakening of trade unions’ ability to organize workers and engage in collective bargaining. For example, Kim Moody (1997: 150) points out that in the early 1900s women employed in networks of small contracting garment firms managed to organize efficiently. Similarly, between the 1930s and 1950s, American truck drivers organized in a single union workers spread out in many different small firms as effectively as auto workers in large, Fordist firms. Silver (2003: 6) also remarks that unions are not necessarily weakened by this reorganization of production,

particularly if it included just-in-time criteria: “In some situations just-in-time production actually *increases* the vulnerability of capital to disruptions in the flow of production, and thus can *enhance* workers’ bargaining power based on direct action at the points of production.”

3.2.b. Changes in the Labor Market

The most common explanation of union decline refers to the decline of manufacturing industries, where unions were highly organized, and the rise of the service sector, where unions were not well-established. The fall of union density simply reflected the contraction of the size of the traditional working-class. This phenomenon was labeled deindustrialization and apparently accounts for a substantial share of the union density decline.

According Daudin and Levasseur (2005: 5-6),

In France, while the growth rate of total employment was 18% over 1970-2002, industrial employment declined by 30%. . . . the French economy created roughly 4 million jobs during 1970-2002, but the manufacturing sector as a whole lost nearly 2 million jobs. . . . As a result of the so-called ‘deindustrialization’ of the French economy, the share of manufacturing employment in total employment decreased from 25.5% in 1970 to 15.2% in 2002.”³⁹

Union density dropped considerably in traditional manufacturing sectors (Visser 2000: 274). In the steel and mining industry, where metalworkers’ federations had been the

³⁹ However, Daudin and Levasseur also note that temporary work and domestic outsourcing mean that some jobs that used to be counted as “industrial” by official statistics are now counted as “services.” Similarly, Moody (1997: 187) remarks: “The industrial workforce also includes millions of workers in transportation, and telecommunications, who show up in the service-sector columns of the official statistics. Many of the ‘services’ provided by these workers, however, have become part of the production process itself as industry has altered technologically, decentralized, and internationalized. If these workers were recorded as employed in industry, this would place another seven-and-a-half million workers in the EU in the industrial sector, and over six million in the United States.”

strongest of the French labor movement, union density dropped from 18.4 percent in 1974 to 6.9 percent in 1993; in the textile-apparel industry, during that same period union density went from 18.1 percent to 4.5 percent (Visser 2000: 274).

There are different accounts of deindustrialization. Some authors stress endogenous factors, such as technology and rising productivity, and draw a linear picture of economic development, from agriculture to industry and then service. According to this perspective, “deindustrialization . . . would have occurred without globalization” (Brady and Denniston 2006: 300). Others, however, while acknowledging the role of endogenous factors in the emergence of deindustrialization, also point out exogenous factors associated with globalization. Although at an early stage globalization may foster manufacturing employment—as a result of growing exports and inward Foreign Direct Investment (FDI) (Brady and Denniston 2006: 301-05)—and even support union density if unions are strong in export sectors (Scruggs and Lange 2002: 130), at a later stage it can have the opposite effect as developing countries expand their manufacturing workforce and as foreign imports and outward FDI increase. Advanced industrial economies facing the competition of developing countries will invest in high-value added production at the expense of domestic manufacturing, thereby contributing to deindustrialization (Brady and Denniston 2006: 304-05). The causal chain would thus be: globalization → deindustrialization → union decline.

The evidence does not support this causal chain. First, as Wallerstein and Western (2000: 362) point out, “The employment share of secondary industries in OECD countries fell at about the same rate in the 1970s as in the 1980s, but unions generally grew in the 1970s and declined only in the later decade.” Second, most trade and FDI flows take place

between advanced industrial economies with similar levels of employment in manufacturing industry. France's most important trade partners are member states of the European Union (EU) with a similar occupational structure. Even in merchandise trade (of which manufacturing constitutes more than 80 percent), in 2004 61.9 percent of French imports came from the EU25, 6.4 percent from the United States, 3.1 percent from Japan, and 2.3 percent from Switzerland. The only emerging country ranking among the top sources of merchandise imports was China with 4.7 percent.⁴⁰

There is no doubt that some French firms close factories in France and relocate them in emerging countries or outsource their operations to firms located in these countries (i.e., offshoring), but this phenomenon remains too marginal to be an important cause of deindustrialization. Between 1995 and 2001, on average 6,370 French jobs per year were relocated toward low-wage economies (INSEE 2006: 72) while another 7,175 per year were relocated toward the EU15. At the same time, inward FDI flows created jobs in France even in industrial manufacturing sectors. For example, in 2005 the French automobile manufacture and equipment sector was the second largest recipient of FDI, with 11.5 percent of total inward FDI, closely following software and IT services, which received 12.6 percent of total inward FDI (IFA 2006: 26).

Although globalization is not at the origin of deindustrialization, the latter still fostered union decline. It is difficult to isolate and determine the exact effect of deindustrialization on union density. Western (1997: 151) claims that "regression analysis shows that only 10 percent of the variance in union density decline in the eighteen countries can be explained by falling employment in secondary industries." For

⁴⁰ WTO, Country Profiles.

Ebbinghaus and Visser (1999: 142), “structural change accounts for 40 percent . . . of the measured decline in union density between 1970 and 1992.” One thing is sure, however: deindustrialization happened in similar ways in all OECD countries whereas union density patterns varied substantially across countries. Furthermore, union density declined even in the public service sector (Visser 2000: 272), where deindustrialization was not an issue at all.

3.2.c. The Increase of Capital Mobility

Insofar as the ability of trade unions to gain and retain members is associated with their collective bargaining strength, a decline of the latter will undermine membership recruitment and retention. The weaker unions are, the more difficult it will be for them to deliver the incentives necessary to consolidate their membership. Increased capital mobility plays a special role in this process, for it facilitates exit options of firms that do not want to make concessions to unions. The use and threat of relocation and offshoring enhance managerial power relative to that of labor (Brady and Denniston 2006: 305, Slaughter 2007: 344). Globalization increases the credibility of such threats. Since France has the lowest union density rate in Europe, firms will not necessarily increase their bargaining power simply by investing in another West European country. It is the threat of moving more than the actual move that grants additional leverage to capital. Therefore, management can force trade unions to make compromises or sacrifices in terms of working conditions, wages, and even workforce, that they would not have accepted otherwise. Moreover, “increasing global investment opportunities prompt employers to adopt a more confrontational, antiunion strategy. This struggle hinders union density growth by

diverting resources and, if successful, reducing membership” (Scruggs and Lange 2002: 129).

However, as in the case of changes in the labor market, simply stressing the effect of capital mobility on labor’s bargaining power does not account for the variation of union density patterns across EU or OECD countries. We need to go beyond structural factors and look at the way domestic labor institutions condition their effects.

3.3. Institutional Factors

Insofar as the institutional configuration varies across countries whereas structural factors remain relatively constant, institutional factors are the key to accounting for cross-national variation in union density (Brady 2007, Western 1997). Labor institutions—or what I call the industrial relations arena—structure the range of options available to unions to deal with cyclical and structural factors (Ebbinghaus and Visser 1999: 154-55, Scruggs and Lange 2002: 130). Where labor institutions are weak, trade unions have less resources to face these factors and, therefore, union decline is likely to be steeper.

Several aspects of French labor institutions hinder French trade unions’ ability to recruit and retain members.⁴¹ First, there is no closed-shop system ensuring access to a pool of members or a check-off system guaranteeing that members will pay their dues. Union leaders have to recruit members on the shop floor and afterward ensure that they

⁴¹ In their ranking of institutional scores—based on the level of bargaining and corporatism, the existence of Ghent unemployment schemes, and the extent of workplace access—Scruggs and Lange (2002: 139) rank France among the OECD countries with the weakest labor institutions. It gets an institutional score of 0.54, close to the US (0.00), Canada (0.04), Japan (0.74), and the UK (0.93), but very far from Germany (1.44), Italy (1.48), and Nordic countries (Finland Sweden, etc.) that pass 3.00.

pay their monthly dues (Goetschy 1998: 366). According to Chris Howell (1992b: 186), “Union pluralism makes these features problematic because they imply that one union will gain at the expense of others and that one union can gain a stranglehold on particular firms or industries.” Insofar as it has been a permanent feature of French labor institutions throughout the twentieth century, this dimension cannot account for union growth or decline. Nonetheless, it did deprive unions of resources to face the structural factors that I described above.

Second, in France union density suffers from the level of coverage provided by collective bargaining agreements. The latter are automatically extended to almost all workers, including non-unionized workers. In 1990, with 92 percent of coverage France had the second highest coverage rate among OECD countries (Wallerstein and Western 2000: 358).⁴² Insofar as agreements are extended to non-unionized workers, there are fewer incentives to join unions and more reasons to free ride (cf. Olson 1965).

Third, the level of decentralization of collective bargaining negatively affects union power and density. Bargaining was temporarily centralized in 1968, when unions negotiated the Grenelle Agreements in the wake of the May protests, but then returned to its normal state of relative decentralization. In 1982, however, the Auroux Laws of the PS-led government rewrote one-third of the French labor code and deepened the decentralization of collective bargaining by increasing the role of work councils in firms and establishing compulsory annual bargaining—but not agreement—at the firm and branch level (Howell 2006: 166-67). The Auroux Laws required strong local unions to

⁴² The leading country was Finland with 95 percent of coverage. After France, followed Belgium (90 percent), Italy and Sweden (83 percent), Australia (80 percent), Germany (76 percent), Norway (75 percent), Denmark (74 percent), and Austria (71 percent). The lowest coverage rates were in Canada (38 percent), Japan (21 percent), and the United States (18 percent) (Wallerstein and Western 2000: 358).

yield results, but beyond the legal recognition of union delegates and access to greater resources (experts, time off for union duties, office space), little was done to strengthen them (Howell 2006: 168). Since the Auroux Laws represent the primary instance institutional change in French industrial relations during the period of union decline (late 1970s to early 1990s), it is likely that they are an important factor behind the sharp drop in union density in France.

Finally, the fluctuation of union density is shaped by interorganizational relations. Where there is a history of union-employer collaboration to enhance productivity, employers have to pay a high cost for using antiunion strategies. In contrast, where there is no such history, as in France, employers pay a low cost for exercising their exit power afforded by globalization (Scruggs and Lange 2002: 131). Moreover, if unions are divided, as in France, resistance to employers is likely to be weak: “unions are most vulnerable to employer hostility and to subsequent membership loss where they are fragmented, weak, and combative towards employers” (Scruggs and Lange 2002: 131).

Therefore, the extent of union decline in France is best explained by institutional factors. Cyclical and structural factors played a role, but it is the particular configuration of the French industrial relations arena that accounts for the particularly low level of union density. Nonetheless, perhaps the institutional change fostering union decline was itself a product of globalization. Institutional change would thus simply be an intervening variable in a causal chain triggered by globalization. One of the motivations behind the Auroux Laws, for example, was the desire to enhance flexibility and boost exports (Western 1997:

163).⁴³ However, the literature on varieties of capitalism (Berger and Dore 1996, Hall and Soskice 2001, Kitschelt et al 1999) has shown that countries respond in different ways to global pressures. Globalization does not push industrial relations systems to converge toward a decentralized model of collective bargaining. Scruggs and Lange (2002: 136) point out that “there has not been a systematic shift toward an Anglo-American model of industrial relations.” Similarly, Miriam Golden (2000: 48, 52) argues that “globalization fails to exercise any statistically significant impact on labor market institutions. . . . While many have voiced fears that international economic pressures may erode unions and associated bargaining practices and institutions, there is little evidence that has been occurring.” The evolution of industrial relations is affected by cyclical and structural factors, but also stems from a political process constrained by crystallized power relations and inherited legacies..

4 | CONCLUSION

In the late 1970s, class politics, the dominant resource mobilization strategy of French labor organizations, entered a crisis. The latter involved a significant decline of the cultural, organizational, and political practices that had characterized the postwar era. Here I have focused on a specific indicator of the crisis of class politics, namely, unionization or union density as the expression of class-based and class-oriented collective action. In

⁴³ Another inspiration was the ideal of workers’ self-management and the antistatism of the CFDT. Several members of the socialist government, including Finance Minister Jacques Delors, were close to the CFDT. Although they did not necessarily believe in workers’ self-management, they shared with the CFDT a deep antistatism. Hence their hope that social actors would bargain without state intervention (Howell 1992a, 1992b).

France, union density fell dramatically in the late 1970s and early 1980s to stabilize only in the mid 1990s. I have shown above that this sharp decline was not the product of globalization. Cyclical and structural factors contributed to union decline but their effect was conditioned by domestic labor institutions.

The sharp union decline implied in the crisis of class politics eventually forced labor organizations to engage in a series of organizational reforms aimed at ensuring their maintenance. As I will show in chapters 5 and 6, these organizations experienced the crisis of class politics differently and, because of their respective resource endowments, took different paths to resolve it. In doing so, they revised their strategies toward globalization.

The Competitive Challenge: The Rise of the Antiglobalization Movement

This chapter traces the rise and impact of the antiglobalization movement in France.⁴⁴ Protests against globalization are often presented as a backlash against the increasing influence of foreign cultures, particularly American culture (Gordon and Meunier 2001, Huntington 1996), or against the social dislocation that the expansion of market forces brings about (Birchfield 2005, Castells 1997, Kapstein 1996, Rodrik 1997). Such accounts fail to specify the mechanisms linking these changes to the behavior of socio-political actors. Any causal relationship between globalization and collective action is difficult to specify in analytical terms because the concept of globalization is generally vague and ambiguous. We need thus to distinguish the sources of collective action from its form, discourse, and goal. It is not because some actors frame their claims in terms of globalization that the latter is the actual cause of collective action. As Sidney Tarrow

⁴⁴ Many opponents of globalization dislike the label “antiglobalization” and point out that they are not against globalization as such but against *neoliberal* or *corporate* globalization. They stress that this distinguishes them from nationalists and prefer to be called “movement for global justice” or “alterglobalist.” Nonetheless, I use the term “antiglobalization” because these groups are opposed to globalization *as it is taking place today* and are united by a common enemy rather than a common goal or agenda.

(2002: 236) points out, “concrete actors with political agendas draw on the symbols of globalization but are not determined by it.”

Several scholars of social movements working in the political process tradition⁴⁵ have identified the sources of antiglobalization movement not so much in globalization as such as in the new political opportunities expanding at the domestic and, above all, international level (see della Porta and Tarrow 2004, della Porta et al 2006, O’Brien et al 2000, Smith et al 1997, Smith and Johnston 2002, Tarrow 2001, 2002, 2005). For example, Tarrow distinguishes globalization—understood as “increased flows of trade, finance, and people across borders” (2005: 8)—from “complex internationalism,” that is, “a dense, triangular structure of relations among states, nonstate actors, and international institutions, and the opportunities this produces for actors to engage in collective action at different levels of this system.” (2005: 25) The multilateralism and the international institutions that constitute complex internationalism expand opportunities for nonstate actors by diffusing information, providing common targets, fostering the convergence of demands, and bringing together activists from all over the world in international events like counter summits (Tarrow 2002, 2005).

This convergence involves the recasting of varieties of old and new demands under a new common label. In this respect, the concept of globalization, with the ambiguity that made it a poor candidate for rigorous analysis, is a great symbolic resource for mobilization because it has enormous “bridging” capacity. As Tarrow (2005: 73) points out, it brings together “opponents of free trade, supporters of a cleaner environment, those

⁴⁵ Although it acknowledges the role of organizations and collective action frames, the political process model stresses the effects of shifts in the political opportunity structure on mobilization. For reviews of this model, see McAdam (1999), McAdam et al (1996), and Tarrow (1998).

who demand access for Third World farmers to Western markets, opponents of neoliberalism, and supporters of global democracy.” According to della Porta et al (2006: 22), this shift from single-issue to global concerns is one of the distinctive features of the antiglobalization movement.

The international political process model developed by Tarrow and his colleagues has the merit of stressing the political-institutional rather than economic sources of collective action. It is particularly useful to account for the transnational strategies that socio-political actors pursue and the targets they choose. However, this model does not integrate in its analysis the continuity between previous waves of mobilization and the contemporary antiglobalization movement. For example, in their otherwise remarkable study of the mobilization against the G8 in Genoa in 2001 and of the European Social Forum in Florence in 2002, della Porta et al (2006) pay only lip service to this continuity. They initially state that “organization, communication, frames, and repertoires mainly come from earlier protest cycles but are adapted, at least in part, to the new global challenges,” and note rightly that the continuity is often visible in “the histories of the activists and their organizations” (2006: 21-22) but this point is not really part of their analysis afterwards. Like many scholars of the antiglobalization movement, they are more interested in novelty than continuity, in transnational networks than domestic roots.

This chapter builds on the political process model but focuses on the organizational and ideological lineages of the antiglobalization movement. It argues that in France this movement is actually a “spin-off” movement, that is, a movement drawing its impetus and inspiration from preceding movements and contentious events (cf. McAdam 1995). Stressing this “spin-off” dimension allows me to show not only how organizations

constantly reinvest their resources in new venues so as to maintain themselves but also that established organizations like parties and unions often play the role of incubators for challengers. I will first describe how major strikes that took place in 1995 fostered the institutionalization of mobilization networks and of a new collective action frame that subsequently underlain the rise of the antiglobalization movement in the second half of the 1990s. To identify the particular features of this movement in France, I will discuss the creation of its primary organizational representative, the Association for the Taxation of Financial Transactions for the Aid of Citizens (ATTAC), and present its analysis of globalization. And finally, I will assess the impact of the antiglobalization movement and present the competitive challenge that it represented for established labor organizations like the CFDT and the CGT.

1 | THE 1995 STRIKES AND THE RISE OF THE “POLITICS AGAINST THE GLOBAL MARKET” FRAME

Although in the late 1980s and early 1990s some events and debates anticipated the antiglobalization movement, they remained punctual. For instance, in 1989, following the example of the 1988 Berlin protests against the IMF and the World Bank (see Gerhads and Rucht 1992) and taking advantage of the meeting of the G7 hosted by President Mitterrand in Versailles, the Center for International Solidarity Studies and Initiatives (CEDETIM) decided to organize a counter-summit that would celebrate the bicentennial of the French Revolution and denounce the debt of third-world countries and global inequalities (Agrikoliansky 2005: 57).

Besides its theme, this event anticipated the antiglobalization movement in several respects.⁴⁶ First, it replaced the traditional anti-imperialism of the French left with international solidarity, put aside Marxist categories, and focused on consensual demands such as the cancellation of the third-world debt. Second, the coalition behind this event was identical to the one that would underlie the antiglobalization movement. It involved NGOs—including religious ones—working on international development and poverty, new radical unions such as SUD (Solidarity, Unity, Democracy),⁴⁷ and leftwing parties like the Greens, the French Communist Party (PCF), and the Trotskyite Communist Revolutionary League (LCR).

However, in spite of the novelty and media coverage of this event, most actors played primarily a symbolic role and did not reconsider their claims and priorities. As Annick Coupé, one of the leading founders of SUD-PTT and spoke person for the Group of Ten (*Groupe des dix*), explains:

At the time, we had a national [*hexagonale*] vision of things. We felt that things were changing at the international level and that these changes could threaten public services, but we were really behind on all these issues. ... We participated in the march [of the July 1989 counter-summit] but we did not play a role in the planning. There were conferences and workshops but we did not attend them. ... It was not a cause in which we were engaged. We focused primarily on the defense of public services and the denunciation of austerity, precarity, job losses, etc. The issue of the third-world debt was not really part of the agenda of trade unions.⁴⁸

⁴⁶ This paragraph relies on Agrikoliansky (2005).

⁴⁷ SUD was created in 1988, when the confederal executive of the CFDT expelled the leadership and rank and file of the Paris section of its postal and communication workers' federation (CFDT-PTT), in the public sector, for having supported unofficial strikes that challenged the new orientation of the CFDT (Bérout 2002: 174-5, Coupé and Marchand 1998). The founders of SUD-PTT were part of a generation of activists that had entered the CFDT in the 1970s. Many of them were active in Maoist, Trotskyite, and anarchist organizations and brought with them their political perspective and practices.

⁴⁸ Interview with author, April 2003. The Group of Ten is a network of radical trade unions that are not members of confederations (see Denis 2001).

Socio-political actors started to recast their claims and modify their agenda only in 1992, during the debate surrounding the referendum on the Maastricht Treaty, and, above all, after the 1995 public sector strikes.

As Sophie Meunier (2000: 5-6) remarks, during the debate over the Maastricht Treaty, “[e]ven if the culprit blamed then was not called globalization but Europeanization, the reasons for discontent were the same.” It was the first major public debate on globalization in France. Only a 50.8 percent majority approved the Treaty. Both the country and mainstream political parties were deeply divided. On the right, the conservative Gaullist party Rally for the Republic (RPR) faced an internal opposition led by Philippe Séguin. On the left, President Mitterrand was challenged by a faction of the PS led by Jean-Pierre Chevènement that eventually left the PS to found the Citizens’ Movement (MDC). Faithful to its anti-European integration stance, the PCF also opposed the Treaty. Trade unions were also divided. While the CFDT supported the Treaty, the CGT and SUD campaigned against it.

The Maastricht Treaty put at the center of public debates over public policy not only economic integration and sovereignty but also the idea of “*pensée unique*,” referring to the hegemony of neoliberalism. The fight against “*la pensée unique*” became afterwards one of the main themes of the 1995 presidential election. The winning RPR candidate Jacques Chirac built its campaign in opposition to the “*pensée unique*.” He called for renewed state intervention in the name of the “Republican pact” and in order to heal the “social divide” (*fracture sociale*).

Later that year France experienced the biggest mass mobilization since the events of May 1968. Indeed, the strikes of December 1995 against RPR Prime Minister Alain

Juppé's plan to reform social security and in defense of public services, pensions, and the welfare state, paralyzed the country for three weeks.⁴⁹ Led primarily by public employees (particularly from the rail public company, SNCF, but also from telecommunications, postal service, and education) and students, the strikes enjoyed the support of wide sectors of French society, including workers in the private sector.⁵⁰ In addition to unions and students, women's groups and civic associations for the unemployed and the homeless also joined in. However, unions were greatly divided, as the CGT launched the movement with the support of SUD and the movement against exclusion while the CFDT refused to reject Juppé's plan. These strikes reproduced a cleavage similar in many respects to the one in 1992 over the Maastricht Treaty. Moreover, the geography of protests during the strikes followed the pattern of the regions that had voted against the Maastricht Treaty (Capdevielle 2001: 100 n3). After several weeks of conflict, Juppé withdrew part of his reform.⁵¹

The 1995 strikes brought about the consolidation of a new collective action frame that extended on a global scale themes that had been introduced by mobilizations against social exclusion in the early 1990s.⁵² Collective action frames do not entail a consensus or support for specific policies, and they are not as elaborated, encompassing, and coherent as

⁴⁹ Juppé's reform, justified in the name of deficit reduction, directly contradicted the promises made by President Chirac a few months earlier, during the presidential campaign, to give priority to social spending so as to ease the social divide. However, according to Palier (2002: 374-75), the trade unions leading the strikes were primarily driven by the defense of their position and power inside the system of social protection.

⁵⁰ Several people talked of strike by proxy (*grève par procuration*) and the number of people participating in marches (around 2,000,000) exceeded by far the number of workers actually on strike (700,000) (Bérout et al 1998: 115).

⁵¹ He only withdrew the part concerning the pensions of public sector workers. Other, more substantial reforms were nonetheless eventually implemented (Palier 2002: 375).

⁵² These mobilizations had been organized by new civic associations close to the far-left, such as Right to Housing (DAL), Right Ahead (DD!!), and Acting Together against Unemployment (AC!).

ideologies. They are interpretive schemata that simplify events and experiences, redefine situations as unjust, and connect several distinct grievances. In order to be effective and turn passivity into action, they must be different from the dominant, conventional discourse that fosters compliance. They must be adversarial and action-oriented. They must transform a given phenomenon into a social problem, attribute the responsibility for it to someone, and possibly propose general solutions and strategies (Benford 1997, Snow and Benford 1988, Snow et al 1986).

I call the new collective action frame that was consolidated during the 1995 strikes the “Politics against the Global Market” frame. Reacting to the neoliberal *pensée unique* that praises the efficiency of the market compared to the distortions created by politics, this frame opposes virtuous and democratic civic politics to corrupt anti-democratic market forces. It puts forward a manichean vision of social reality, civic politics being defined as quintessentially good while the market is a realm governed by the law of the jungle, where individualistic and immoral aspirations prevail at the expense of the common good. It follows that, for ordinary individuals, politics is the realm of empowerment while the market is a realm of powerlessness. The state appears then not as instrument of the bourgeoisie but as the privileged resort of civilization against anarchy, that is, the war of all against all. It stands as the guarantor of rights and equality against the inequality inevitably stemming from the logic of the market, and as the rampart of national cultures against homogenization. But paradoxically, at the same time that it makes the state sacred this frame announces its desuetude, for the market that is being blamed for all evils is no

longer national. It is global and, thereby, all the more meaner because it lies beyond the reach of the nation-state and is therefore more difficult to tame.⁵³

The “Politics against the Global Market” frame interferes, without replacing them, between two discursive poles that have traditionally structured French political debates: The nationalist-protectionist pole, resting upon the postulate of a competition between nations, and the Marxist-internationalist pole, based on the idea of class struggle between workers and capitalists. It is also different from the third-worldist discourse—which is close to the Marxist-internationalist pole but also draws upon social Catholicism—insofar as it focuses primarily on the consequences of globalization in advanced industrial economies rather than developing countries. The “Politics against the Global Market” frame relies on the emblematic figure of the citizen, to the extent that today many people in France even talk of “civic firms” (*entreprises citoyennes*) to refer to corporations acknowledging their social responsibility and abiding by codes of conduct. The citizen has now replaced the blue-collar worker as the symbol of the left.

Collective action frames are neither the mechanical product of structural conditions nor a simple derivative of the local political culture. They are strategically constructed and articulated, under certain material, institutional and cultural constraints, by political agents who draw upon familiar values, categories, and symbols. New frames are not invented out of whole cloth. It is their familiarity that allows them to resonate among the targeted

⁵³ This paradox evokes the dilemma to which the antiglobalization movement will be confronted: If globalization is guilty and actually brings about a loss of state autonomy, then there is not much room for maneuvering and one can hardly blame governments for not implementing the social and economic policies to which the antiglobalization movement aspires; and if, instead, governments still enjoy a real autonomy, the issue is no longer globalization as such but the agenda and determination of political leaders. This latter option would question the identity and *raison d'être* of the antiglobalization movement while at the same time depriving it of a rhetoric that has demonstrated its rallying and mobilizing capacity.

public. In this sense, “what gives a collective action frame its novelty is not so much its innovative ideational elements as the manner in which activists articulate or tie them together” (Snow and Benford 1992: 138).

In France, the “Politics against the Global Market” frame invokes widely shared norms such as social equality, solidarity and the common good, familiar categories like market and citizen, and mobilizes strong symbols like the public service, the social entitlements of the Republic, and the threat of tyranny. It avoids old themes of the Left, such as the class struggle, and stresses the inclusive identity of citizen, thereby widening its appeal. Moreover, its focus on the interventionist role of the state is congruent with the Republican statist political culture and thus does not require any justification.⁵⁴ In countries where the critique of the market was not shaped as much by statism and Marxism and where the reform of the public sector did not crystallize fears about globalization as in France in 1995, the “Politics against the Global Market” frame will probably not resonate so strongly and one can expect opponents of globalization to rely on a slightly different collective action frame.

The “Politics against the Global Market” frame did not emerge during the 1995 strikes as such. As I pointed out earlier, it was many respects anticipated by the 1988 Berlin protests against the IMF and the World Bank and the 1989 Paris counter-summit

⁵⁴ In France, it is the opposite claim, namely, that the role of the state should be limited, that sparks controversies and requires a special justification. Except for *Démocratie libérale*, a small rightwing party led by Alain Madelin, not a single French political party dares to openly defend a liberal, pro-market and free trade agenda. Thus, Socialist Prime Minister Lionel Jospin triggered a strong public debate when he declared after the Michelin lay-offs in 1999, that he would not intervene in this affair and that people should not expect the state to do everything. The pressure was strong enough to lead the PS to subsequently propose a law of “social modernization” to tighten the regulation of lay-offs. Jospin’s statement about the role of the state still inspires commentaries and debates, as the recent publication of a book centered on its impact illustrates. See E. Aeschmann, “Les mots pour ne pas le dire,” *Libération*, October 28, 2006.

against the G7. Similarly, Jean-Gabriel Contamin (2005) has noted that this frame underlain the writings and demands of several intellectuals and groups several weeks before the 1995 strikes. Furthermore, Contamin (2005: 253-56) has stressed that during the strikes the use of this frame was minor and originated primarily from far left organizations such as AC!, SUD, and the LCR, that were trying to give a new legitimacy to old claims so as to rally new supporters and allies.

Nonetheless, the 1995 strikes were a turning point because afterwards an increasing number of actors began to engage in “global framing,” that is, “the use of external symbols to orient local or national claims” (Tarrow 2005: 60). The 1995 strikes played the role of a “brokering” event by bringing together and consolidating the ties between a wide range of organizations critical of the liberal turn of the Socialist Party that did not really cooperate in the past. This informal ad hoc alliance came to be called the “left of the left” or the “leftist left” (“*Gauche de la gauche*” or “*Gauche de gauche*”) by the media and activists. Most of these organizations later participated in the emergence of the antiglobalization movement in France and the creation of ATTAC. Moreover, mobilizations against social exclusion, state retrenchment, and economic liberalization were henceforth called “*the social movement*,” thereby suggesting that there was a *single* social movement active in France.⁵⁵ This identification between the strikers and other social categories allegedly affected by economic integration contributed to the adoption of the “Politics against the Global Market” frame because people saw themselves as confronting the same underlying

⁵⁵ “The” social movement seems thus to have replaced the labor movement (*le mouvement ouvrier*) as the vanguard in the political imaginary of some sectors of the left.

problem, namely, the spread of neoliberalism and the deepening of economic integration at their expense. As McAdam (1995: 236) remarks,

In retrospect, scholars may see a cycle—especially a reform cycle—as a cluster of 6, 7, 8 . . . n discrete social movements, but this view almost invariably distorts the perspective shared by participants at the time. In their view, they are but a part of broad and rapidly expanding political-cultural community fighting the same fight on a number of related fronts. And a significant part of what links and defines these various groups as a coherent community is their reliance on the same tactical forms.

The close ties and sense of collective identity fostered by the 1995 strikes favored the diffusion of the “Politics against the Global Market” frame. This frame became institutionalized in everyday public discourse and subsequently picked up by other actors for different purposes. Some established organizations, particularly the PCF, progressively redefined their claims through this frame. In doing so, they gave it an additional legitimacy that the far left had so far failed to obtain.

Activists and militants themselves see the 1995 strikes as a key turning point. According to Daniel Ciréra, head of international relations for the PCF:

Since the early 1990s and the ratification of the Maastricht Treaty, the idea according to which decisions depended less and less on the national framework was very strong. There were Europe, financial markets, and globalization. At the time, the debate was dominated by the claim that the state could no longer influence decisions, that the economy was in charge, that decisions were being made somewhere else. After the 1995 strikes, it was no longer possible to talk in the same way. These events showed that it was possible to carry a struggle in one’s country and obtain things or at least prevent them from happening. The 1995 strikes had a structuring effect on subsequent debates.⁵⁶

Similarly, Annick Coupé, SUD-PTT founder and Group of Ten spoke-person, explains:

[The 1995 strikes] changed the nature of issues. Afterwards, although mobilizations would focus on this or that aspect, on this or that sector, each time the claims were placed in a more general context. . . . I think that after 1995, it was easier to

⁵⁶ Interview with author, July 2002.

understand neoliberal globalization. I believe it is thanks to the movement itself. Today, when we talk about the privatization of public services, deregulation, and liberalization, people understand in broad terms what we're talking about.⁵⁷

This depiction and this insistence on a new sense of self-efficacy are widespread in partisan analyses and regularly came up in interviews with political and labor leaders.

The diffusion of the “Politics against the Global Market” frame after the 1995 strikes is apparent in the commercial success of a number of essays denouncing the evils of globalization⁵⁸ and in the discourse of opponents of the Multilateral Agreement on Investment (MAI) in 1997 and 1998. Negotiated within the Organization for Economic Cooperation and Development (OECD), the MAI aimed at providing a comprehensive framework for international investment. A coalition made of unions from the entertainment sector, the civic associations and unions of “the” social movement, the Greens, José Bové’s Peasant Confederation (CP), and think-tanks like the Observatory of Globalization, managed to bring the French government to withdraw from the negotiations, thereby provoking the collapse of the agreement. In contrast to the December 1995 strikes, that had been a purely domestic event, this time the mobilization benefited from transnational networks composed of American and Canadian NGOs and unions that had been active in the campaign against the North American Free Trade Agreement (NAFTA) and that quickly spread the content of the MAI over the Internet (Kobrin 1998, *Observatoire de la mondialisation*, 1998).⁵⁹

⁵⁷ Interview with author, April 2003.

⁵⁸ The most noticeable case is undoubtedly Viviane Forrester’s *The Economic Horror*. Published in 1996, it quickly sold 300,000 copies and was translated in 18 languages (Boltanski and Chiapello 1999: 742 n8).

⁵⁹ See also C. de Brie, “Vers une mondialisation de la résistance: Comment l’AMI fut mis en pièces,” *Le Monde diplomatique*, December 1998.

Their reliance on the “Politics against the Global Market” frame is obvious, for example, in the “Call of 10 February 1998,” made by unions of the movie industry: “[The MAI] is leading us to a real change of civilization. We are going from the right of peoples to self-determination to the right of investors to dispose of peoples” (quoted in *Observatoire de la mondialisation 1998*: 54). Similarly, the “Manifesto of 28 April 1998” of the Coordination against the MAI, invoked the French and the universal human rights declarations to denounce the antidemocratic character of neoliberal globalization.⁶⁰ In the same vein, in late 1999 the Call for the Citizen Control of the WTO, signed by the majority of antiglobalization leaders of the Left and many celebrities, stated:

More and more every day, the market takes control of life. It organizes work, sets salaries, moves factories, decides what we drink, breathe, or eat. It cuts down on social progress, eliminates differences, destroys public services, annihilates democracy and peoples’ right to self-determination. More and more every day, globalization accelerates without any democratic institution ever deciding it. . . . More and more every day, freedom is annihilated in the name of free trade.⁶¹

The “Politics against the Global Market” frame derived its popularity not only from its cultural resonance but also, as Tarrow (2005: 73) pointed about the symbol of globalization, from its “frame bridging” capacity and its location at the intersection of many concerns, particularly those of nationalists who fear for national identity and sovereignty, those of opponents of neoliberalism who worry about inequality and the erosion of the welfare state, and those of environmentalists.⁶² The possibility of extending

⁶⁰ Coordination contre l’AMI, “Le Manifeste du 28 Avril 1998,” <http://attac.org>.

⁶¹ Etats Généraux pour le contrôle citoyen de l’OMC, “Appel pour le contrôle citoyen de l’OMC: L’internationale du capital triomphe, celle des êtres humains aspire à naître,” <http://www.etats-generaux.ras.edu.org>.

⁶² “Frame bridging” refers to “the linkage of two or more ideologically congruent but structurally unconnected frames regarding a particular issue or problem.” (Snow et al 1986: 467)

the “Politics against the Global Market” frame to a multitude of problems and connecting them to each other, widens its potential audience and fosters its mobilization capacity. Moreover, this frame provides a convenient way to criticize free markets and capitalism without having to rely on a Marxist vocabulary and framework. It also allows unions to defend their interests without necessarily being accused of undermining the general interest dear to the Republican political culture.

Together with the mobilizations against social exclusion in the early 1990s, the 1995 strikes provided the cultural and organizational context within which the antiglobalization movement subsequently developed. In becoming institutionalized in everyday public discourse, the “Politics against the Global Market” frame constituted a discursive paradigm logically excluding or downplaying competing understandings of reality. It turned into what Snow and Benford (1992) call a “master frame,” that is, an encompassing collective action frame connecting several movement specific frames. The more the master frame is elaborated and flexible—as is the case with the “Politics against the Global Market” frame—the greater its appeal and mobilizing potency (Snow and Benford 1992: 140). New master frames are heavily shaped by initiator movements and have a constraining effect on the framing efforts of spin-off movements (McAdam 1995: 228, Snow and Benford 1992: 144-45).⁶³ It is through institutionalized master frames that subsequent movements make sense of long-term structural changes such as globalization (cf. McAdam and Sewell 2001: 118-119).

⁶³ Snow and Benford (1992) do not talk of “initiator” and “spin-off” movements—those are McAdam’s (1995) words—but refer to “early” and “late” movements in a similar sense.

But past struggles and contentious episodes shape not only how actors subsequently interpret the socio-political reality but also what they do. They shape the repertoires that constrain the behavior and claims of actors (McAdam 1995).⁶⁴ As Christophe Aguiton—a member of the LCR who was a leading figure of the mobilizations against social exclusion and who participated in the foundation of SUD in 1988, AC! in 1994, and ATTAC in 1998—explains: “The emergence of all these new movements during the 1990s allowed us to accumulate a great deal of experience and capital. . . . When new issues like the Asian financial crisis appeared, we relied on what we knew. These movements of the 1990s are our toolkit.”⁶⁵ The antiglobalization movement, like all “spin-off” movements, derived hence its impetus and inspiration from an initiator movement.

2 | ORGANIZING AGAINST GLOBALIZATION: THE CASE OF ATTAC

Social movements are collective phenomena that go beyond a single organization. They are primarily constituted by networks of formal and informal organizations. However, some social movement organizations play a bigger role than others because they have access to more resources and enjoy a larger influence. In France, no organization plays a larger role amidst the antiglobalization movement than the Association for the Taxation of Financial Transactions for the Aid of Citizens (ATTAC). In only a few years, it managed to get incredible media coverage (see Figure 4.1), thereby consolidating the impression that

⁶⁴ Repertoires are familiar modes of organizing and acting to which people turn, even though “in principle some unfamiliar form of action would serve their interests much better.” (Tilly 1986: 4)

⁶⁵ Interview with author, March 13, 2002. It is worth stressing, however, that spin-off movements do not simply adopt or reproduce the ideas and practices of initiator movements. They instead creatively interpret and adapt them (McAdam 1995: 229).

it embodies the antiglobalization movement in France.⁶⁶ Some commentators even claim that ATTAC has become “the most public face of the antiglobalization movement in much of Europe.”⁶⁷ At the international level, ATTAC also played a key role in the creation of the World Social Forum in 2001. The case of ATTAC provides thus a window onto core features of the emergence and discourse of the antiglobalization movement.

Figure 4.1: ATTAC in Leading Leftwing Newspapers

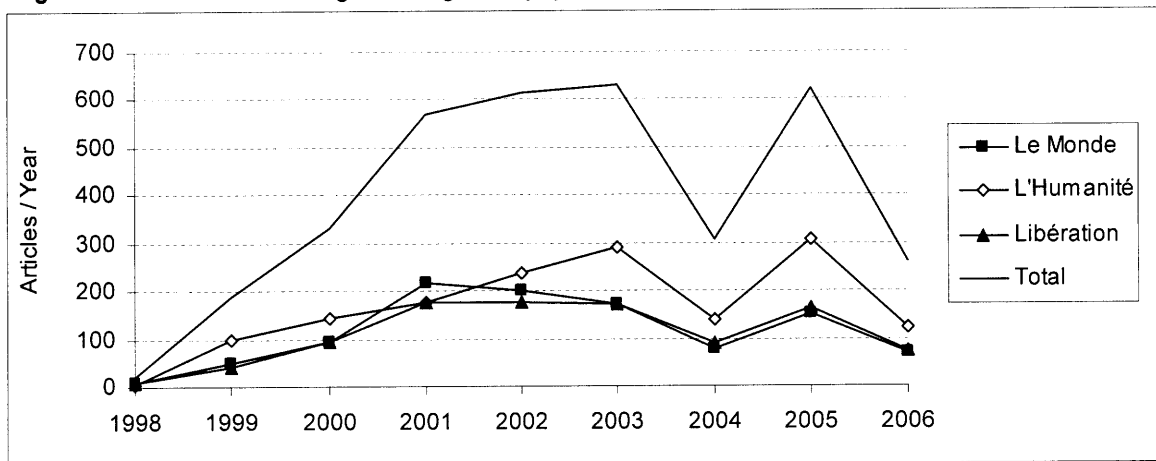

Sources: *Le Monde* and *L'Humanité*, Electronic Archives; *Libération* data based on Biblio Branchée.

ATTAC was founded in 1998, in the wake of the Asian financial crisis and at the beginning of the mobilization against the MAI.⁶⁸ ATTAC’s founding members were very diverse. They included individuals as well as organizations that joined in as legal entities (*personnes morales*) and counted as one member. There were: (1) trade unions, representing peasants, teachers, postal workers, and lawyers, as well as workers’

⁶⁶ The media coverage data indicates, however, that ATTAC’s significance in the public debate is declining. Although it was highly active and visible in 2005 because of its leading role in the campaign against the European Constitutional Treaty, the declining trend seems to have resumed in 2006.

⁶⁷ Naomi Klein, “A Fete for the End of the End of History,” *The Nation*, March 19, 2001.

⁶⁸ For an account of ATTAC’s creation, see Ancelovici (2002).

federations of the CGT and the CFDT; (2) civic associations, such as DAL, DD!!, and AC!, as well as others, defending reproductive rights or the separation of church and state (the *laïcité*); (3) newspapers and magazines, such as *Le Monde diplomatique*, *Alternatives économiques*, *Charlie Hebdo*, and *Témoignage chrétien*; and (4) public intellectuals like the late René Dumont, Viviane Forrester, Susan George, Gisèle Halimi, René Passet, Ignacio Ramonet, and singer Manu Chao (ATTAC 2000a : 114-15).

The founders of ATTAC were not new comers. The biographical and organizational continuity with past struggles and waves of mobilizations is obvious. Numerous founding organizations have existed for several decades while others were created in the early 1990s during the mobilizations against social exclusion (Figure 4.2).

Figure 4.2: ATTAC's Organizational Lineages

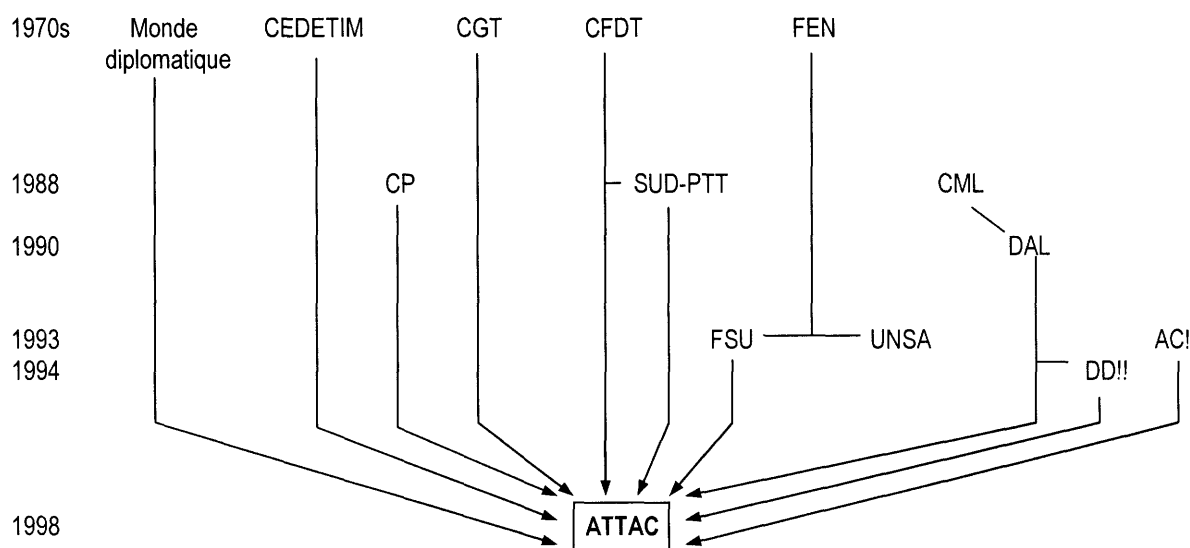

Notes: 1/ CEDETIM = Center for International Solidarity Studies and Initiatives; CP = Peasant Confederation (José Bové); FEN = National Education Federation; FSU = Unitary Trade Union Federation; UNSA = National Union of Autonomous Trade Unions.

2/ The CGT participated in the creation of ATTAC through its engineers and technicians federation (UGICT-CGT) and its finance federation; the CFDT participated in the creation of ATTAC through its banking federation and its transport and equipment federation (FGTE-CFDT); these two CFDT federations were dissenting federations that questioned the orientation of their confederation.

The creation of ATTAC was literally a joint venture between a wide range of organizations so as to institutionalize cooperation between them. A priori, the collective goods to which ATTAC aspires are remote and conducive to free riding and thus cannot by themselves constitute strong incentives to mobilize and cooperate. In fact, an important part of ATTAC's discourse is framed in terms of "collective evils," such as massive inequalities, tyranny, society's disintegration, and so forth, rather than collective goods.⁶⁹ From the standpoint of organizational members, the creation of ATTAC was driven primarily by strategic considerations. Participating in ATTAC—a hybrid coalition grouping organizations as much as individuals—entailed access to a variety of resources.

For unions, it was a chance to reach associations and social movements and thereby widen their support network and legitimacy. For example, for Pierre Tartakowsky, ATTAC's secretary general and a member of the CGT, the idea of creating an organization like ATTAC was appealing because the CGT had been thinking about its articulation to "the" social movement for a while: "The idea of an alliance, even in a very vague form, that would take place in the realm of the City and not necessarily in that of labor so as to question the deep trends of the liberal economy, was very interesting."⁷⁰ Similarly, for Annick Coupé, spokesperson of the union network Group of Ten,

Our decision to participate in ATTAC was motivated by two factors. First, it provided a larger framework that allowed to gather different labor forces that . . . were not necessarily willing to work together on a regular basis. Second, there was an associational network that ranged from militant associations to intellectual ones. . . . It could contribute to increase the hope in and credibility of struggles for another world. . . . We got involved in the creation of ATTAC because we thought it would contribute to build power relations [*rappports de force*] and foster the diffusion of issues [related to globalization and the domination of global neoliberalism]

⁶⁹ The expression "collective evils" is from Jenkins (1983: 536).

⁷⁰ Interview with author, March 2002.

throughout French society, beyond workers, to reach citizens. There was no way we or the CGT, the FSU, or any other organization could do that by itself. Doing it together in a large framework gave us more strength.⁷¹

For small civic associations, ATTAC meant access to tangible (facilities, means of communication, etc.) and, above all, intangible (expertise, credibility, social and symbolic capital, etc.) resources. SUD-PTT played a key role in this respect, for in many cities throughout France it provided the meeting place and equipment to organize rallies and actions.

More generally, for both unions and civic associations the fact that the call to create ATTAC originated from the *Monde diplomatique*, one of the leading newspapers of the French Left, made a big difference. It implied immediate access to intellectual resources, legitimacy, and organizational networks cutting across newspapers, parties, unions, associations, and countries, as well as the possibility of reaching an audience representing a “conscience constituency” or “sentiment pool.”⁷² On the other hand, these activists and unionists brought with them a substantial know-how that the intellectuals gathered around *Le Monde diplomatique* did not have. It provided a militant infrastructure for guiding the thousands of people who were joining the organization.

Four factors fostered this joint venture effort. First, in the wake of the 1995 strikes, the 1997 electoral victory of the left, and the 1997-98 mobilization against the MAI, the political context appeared favorable. In such favorable political contexts, as Zald and McCarthy (1980: 16) point out, organizations “scent victory” and are more likely to cooperate. Second, the close ties and networks that were consolidated during and after the 1995 strikes fed trust among actors and, thereby, favored cooperation (cf. della Porta and

⁷¹ Interview with author, April 2003.

⁷² Snow et al. (1986: 467) define a “sentiment pool” as an aggregate “of individuals who share common grievances and attributional orientations, but who lack the organizational base for expressing their discontents and for acting in pursuit of their interests.”

Diani 1999: 120-23, Levi and Murphy 2002: 14).⁷³ Third, actors shared a common diagnosis of the socio-economic and political situation. They shared a general understanding of globalization consistent with the “Politics against the Global Market” frame, a suspicion toward mainstream parties, a refusal of the liberal turn of the PS, and a strong attachment to what Lichbach and Almeida (2002: 29) call “global ideals” (global justice, peace, human rights, sustainable development, etc.). Furthermore, their identification with the “leftist left” and “the” social movement constituted a common ground that not only shaped their definition of the situation but also guided their tactical and organizational choices by privileging certain natural allies and modes of representation.⁷⁴ Finally, the fact that ATTAC initially focused on the demand for a global tax on capital mobility—the Tobin Tax—made it easy to rally a wide support.⁷⁵

Several distinctive features of ATTAC’s individual and organizational membership deserve to be underscored. First, intellectuals play a central role as active rather than just symbolic members. This is reflected in the willingness to popularize abstract and complex economic issues (that is the purpose of ATTAC’s Scientific Council) and in ATTAC self-definition as “a movement of popular education oriented towards action.”⁷⁶ Second, there is a strong predominance of trade unions of the public sector, in particular teachers’ and

⁷³ There is a circular dynamic at work: at first, political entrepreneurs took advantage of these networks to create ATTAC, and, subsequently, ATTAC institutionalized them—for example, by allowing organizations to become members as legal entities—and expanded them.

⁷⁴ On the way shared symbols and interpretive frameworks facilitate coordination and exchange, see Ansell (1997).

⁷⁵ ATTAC’s original name was Action for a Tobin Tax for the Aid of Citizens. ATTAC (2002a: 23-24) proposed that governments impose a 0.05 percent tax on foreign exchange transactions so as to generate about US\$100 billions a year in revenue that could be given to international organizations fighting against inequality and supporting public health, education, and sustainable development in developing countries.

⁷⁶ Most leading members of ATTAC’s Scientific Council are left-wing economists, such as François Chesnais, Michel Husson, Dominique Plihon (current president of the Council), and René Passet. ATTAC’s president from 2002 to 2006 was also professor of economics (cf. Waters 2004: 861-62).

postal workers' unions. In contrast, workers in sectors directly challenged by globalization, such as the apparel-apparel and the electronics industries, are completely absent. In this sense, there does not seem to be a relationship between joining ATTAC and defending specific economic interests. This lack of relation to material incentives is also apparent in the membership of civic associations defending reproductive rights and the separation of church and state, or demanding an increased availability of affordable housing.

This social profile fits studies of participation in European Social Forums (ESF), the main annual meeting of opponents of globalization in Europe since 2002. According to della Porta (2005: 13), during the 2002 ESF in Florence, Italy, 39.4 percent of participants were white collar employees while 22.1 percent were professionals and 14.6 percent were teachers. 48.2 percent worked in public services and 39.2 in private services. Finally, 34.9 had at least a few years of college education.⁷⁷ Similarly, according to Gobbille and Uysal (2005: 107-08), during the 2003 ESF in Paris, France, 46.1 percent of participants worked in the public sector as opposed to 21.6 in the private sector. Low-skilled workers (*ouvriers*) represented only 2.2 percent of participants. Even more than in the 2002 ESF, the proportion of highly educated participants is striking: 69.2 percent had at least a few years of college education, two thirds of which had a college degree.

Several significant absentees from the creation of ATTAC need to be mentioned. First, the three main labor confederations (CGT, CFDT, Workers' Force [FO]) had a very low profile—the CFDT and the CGT participating only through small workers' federations—whereas not a single political party officially played a role, although some

⁷⁷ This trend is even more accentuated for French participants in the 2002 ESF: 47.6 percent were white collar employees and 19 percent were teachers, 53 percent worked in public services, and 71.9 percent had at least a few years of college education (della Porta 2005: 13).

founder members were also members of political parties.⁷⁸ Representatives of the entertainment sector and environmentalist organizations (the only environmentalist association among founder members is Friends of the Earth) too did not join ATTAC. The absence of environmentalist organizations clearly distinguishes the French antiglobalization movement from, say, its American equivalent. Several authors (e.g., Kriesi et al 1995) have noted the continued salience and conflicting character of the class cleavage in French politics and, as a result, the relatively low mobilizing capacity of so-called new social movements such as the environmentalist movement. The absence of representatives of the entertainment sector is a lot more puzzling because they regularly denounce the Americanization of French culture and were very critical of the Uruguay Round of the GATT negotiations. Moreover, they already had ties with antiglobalization organizations insofar as they were at the center of the mobilization against the MAI in 1997 and 1998. This should have made them natural founder members of ATTAC.

ATTAC is emblematic of the antiglobalization movement not only because of its emergence and social composition, but also and perhaps above all because of its discourse. ATTAC defines globalization as the convergence of two trends: first, the restructuring of the mode of state intervention in the economy, the liberalization and opening of national markets, and the emergence of global—primarily financial—markets; second, the incorporation of an increasing share of human activities in the market. This perspective led ATTAC to frame a whole series of domestic issues as consequences of globalization and

⁷⁸ In 2001, 125 deputies at the National Assembly were members of ATTAC and there was also an ATTAC coordination at the European parliament. Both at the National Assembly and European parliament Socialist deputies play a key role. On one hand, these deputies have been an important external resource of ATTAC, as they regularly relay its analysis and demand that the Tobin Tax be taken seriously. On the other hand, ATTAC is haunted by the prospect of electoral manipulation and instrumentalization. Multiple affiliations are a double-edged sword that can also jeopardize the autonomy of organizations.

its agents. For instance, during the 2003 protests against the reform of pensions it claimed that the World Bank and the European Commission were at the origin of this reform.⁷⁹ Similarly, during the fall 2005 riots in French poor suburbs, it claimed that the living conditions of the rioters and thereby the riots themselves were a direct product of neoliberalism and globalization.⁸⁰

For ATTAC's former president, Bernard Cassen, "liberal globalization is the inaugural phenomenon. All cleavages stem from it."⁸¹ According to Cassen,

There has always been a market economy. But before, there was a capacity for regulating it. When you were in a national framework—and even, at the beginning, at the European level—there was a political capacity for regulation that was pulverized from the 1980s onward. There was a whole series of changes, including the liberalization of capital mobility, that deprived states—with their consent—of any regulating capacity. Today, there can be no industrial policy. Neither at the national nor European level.⁸²

In order to build a case against globalization, ATTAC needs to show that there is a causal relation between, as Luc Boltanski (1993: 97) would say, the happiness of a malicious person and the misfortune of an innocent. It tries to lay the foundations of a macro theory of domination by insisting on the role of financial markets and multinational corporations. In a manner consistent with the "Politics against the Global Market" frame, the opening sentence of its platform states,

Financial globalization increases economic insecurity and social inequalities. It bypasses and belittles the choices of peoples, democratic institutions, and the sovereign states in charge of the general interest. It replaces them with strictly speculative logics expressing the sole interests of transnational corporations and

⁷⁹ ATTAC, "Appel du Bureau national d'ATTAC France: Mobilisation générale d'ATTAC pendant les 30 jours qui peuvent changer la France!," May 22, 2003.

⁸⁰ ATTAC, "Communiqué d'ATTAC France: Les quartiers populaires subissent au quotidien la violence du libéralisme," November 9, 2005.

⁸¹ Interview with author, July 2002.

⁸² *Idem*.

financial markets. In the name of a transformation of the world presented as a fatality, citizens and their representatives see their power to decide of their destiny contested. (ATTAC 2000a: 16)

According to ATTAC, the causal chains linking the persecutor and the unfortunate are made of three processes. First, a “race to the bottom.” Because capital can now freely scour the world for the highest return, nation-states and local authorities will be forced into a frantic race to please big investors. Labor standards, professional training, cultural production, public health, housing, public services, and the environment will be deeply affected and become stakes of civilization (*enjeux de civilisation*) (ATTAC 2000a: 30).

Second, a decline of sovereignty and democracy. This decline stems in part from the race to the bottom, as global markets decide which national economic policies are good and thereby violate the principle of sovereignty. Sovereignty is also threatened by the construction of a supranational state led by, as ATTAC’s former president Bernard Cassen put it, the “politburo of the Liberal International”: the IMF, the World Bank, the WTO, the OECD, and the European Commission.⁸³ The erosion of sovereignty partakes in the democratic deficit insofar as it questions the authority of representatives of the citizenry. According to Cassen, state regulation and border control are a prerequisite to democracy and sovereignty: “Deregulation and free trade deprive politics of its power. Trade is the opposite of politics. As soon as you no longer control inflows and outflows, you are completely dependant on the exterior for everything and, therefore, you can close the parliament. . . . Restoring a democratic capacity means controlling trade flux.”⁸⁴ Cassen (1997) sees the problem as a growing discrepancy between those who take decisions and

⁸³ Bernard Cassen, “Contre la prolifération du commerce international: Inventer ensemble un ‘protectionnisme altruiste,’” *Le Monde diplomatique*, February 2000.

⁸⁴ Interview with author, July 2002. On the relationship between borders and democracy, see Berger (2002).

those who are affected by these decisions. He argues that there is a fundamental contradiction between the current globalization and democracy:

In the final analysis, it is democracy itself that is the prime victim of free trade and globalization. The way in which they operate actually widens the physical gap separating the centers of decision-making and those affected by those same decisions. . . . Taking responsibility and being obliged to be accountable are the touchstones of democracy. On the assumption that it is their intention to work for the good of all their fellow citizens, what happens when elected representatives and governments are less and less in control of the real decision-makers, who have no real link with their territory, that is to say the financial markets and the vast conglomerates? There is no need to seek further the main factor in the disintegration of societies.

Finally, the third process is the commodification of living organisms. For ATTAC (2000a: 88), the privatization of agronomic and biotechnological research and the concentration of firms in the seed industry constitute a real “hold-up of the living” (*hold-up sur le vivant*) in the name of progress and competitiveness. It substitutes a logic of profit and efficiency for the common good and in doing so threatens the ecological milieu and deprives people of something to which they are entitled. Life, the respect of biodiversity, jobs in agriculture, and freedom are presented as the main victims of the “death-driven political economy” (*économie politique mortifère*) and “biototalitarianism” of multinational corporations and their allies (ATTAC 2000a: 96).

These three processes show that ATTAC draws a clear causal link between local and national problems, on one hand, and changes in the international economy, on the other. Globalization is depicted as being essentially an exogenous shock: democracy, sovereignty, the welfare state model, and social and environmental norms are under assault from something that is foreign to them. In line with the “Politics against the Global Market” frame, the culprits are financial markets, rootless multinational corporations, and

their allies, that is, international financial institutions (WTO, IMF, World Bank, etc.) and governments that have surrendered to the logic of globalization. Globalization is thus denaturalized and understood as a threatening contingent political project rather than an inevitable and irreversible process.

Furthermore, in contrast to traditional Leftist arguments but in line with the “Politics against the Global Market” frame, social classes are surprisingly absent from ATTAC’s discourse (this is all the more surprising considering that several of its leaders come from the far Left and the PCF). There is no reference to the labor or working-class movement (*mouvement ouvrier*), and even old-fashioned “capitalism” is barely mentioned. The new privileged actors are “the” social movement and an active citizenry. Instead of presenting globalization as the result of a macro-structural process bringing about the hegemony of a transnational bourgeoisie or of insisting on the class background of the alleged victims of globalization, issues are framed in terms of citizenship, democracy, solidarity, global markets, financial institutions, and corporations. ATTAC praises civic engagement and claims to be defending not sector or class interests but the common good and society as a whole against market colonization understood as a process of commodification. This departure from class analysis and traditional leftist rhetoric is strategic. As Cassen explains,

There are many people at ATTAC that know very well how to do a perfect class analysis and respect all Marxist standards. It’s not a problem. But it’s not the goal of this endeavor. We are a movement of popular education and our goal is not in the short term but in the medium term. Our goal is to extirpate the liberal virus from people’s mind so that they can function normally anew. This requires a discourse that is not used, otherwise people will tell us “All right, we’ve already seen this, another Trotskyist groupuscule.” Therefore, we need a discourse that may not be scientifically accurate but that people understand. And the results are there to prove

it. If we have so many members, it is because our discourse resonates. If we use a standard Marxist discourse everybody will laugh at us.⁸⁵

ATTAC's analysis—stressing the dissolution of social bonds and solidarities and the risk of a disintegration of society and reactionary backlash—is reminiscent of that of Karl Polanyi, and several leaders of ATTAC regularly invoke his work. Furthermore, in contrast to liberals, Bernard Cassen and other leaders of ATTAC categorically reject the *doux-commerce* thesis according to which trade is a powerful moralizing and civilizing agent.⁸⁶ Many of their arguments come close to what Albert Hirschman (1986: 110) has called the self-destruction thesis, according to which “capitalist society . . . exhibits a pronounced proclivity to undermining the moral foundation on which any society, including its own, must rest.” It follows that, and this is consistent with Polanyi, social and state regulation is necessary not only to defend society but also to protect capitalism from itself. For opponents of globalization, Polanyi's work is appealing partly because it provides an anthropological, non-Marxist critique of the market economy that legitimates crosscutting alliances and state interventionism.

Insofar as from ATTAC's standpoint, globalization is essentially a political product, the solution also lies in politics:

To challenge the domination of finance in a world where everything progressively becomes a commodity, where everything is sold and bought, is to challenge the organization of economic, human, social, and political relations; it is finally to place oneself in an eminently political field with the will to transform the world by means of democratic and civic mobilizations. (ATTAC 2000a: 22)

⁸⁵ Interview with author, July 2002.

⁸⁶ Bernard Cassen, “Contre la prolifération du commerce international: Inventer ensemble un ‘protectionnisme altruiste’,” *Le Monde diplomatique*, February 2000.

ATTAC intends to participate in the public debate by calling out to citizens and playing a role as a “democratic stimulus.” Nonetheless, its celebration of grassroots, civic politics comes hand in hand with an emphasis on the role of the state. It claims that

The framework of nation-states remains, even today, a privileged anchoring place. On the one hand, because it is in this framework that people exercise electoral democracy and political citizenship, and that most great popular mobilizations take place; on the other hand, because states still have operational levers for imposing another economic logic, they remain impossible to circumvent in international relations (ATTAC 2002b: 26).

ATTAC’s propositions to tame the forces of globalization and solve some of the problems associated with it refer primarily to the creation and enforcement of regulations through state intervention and supranational coordination. Some of its demands are defensive. This is for instance the case of a moratorium on privatizations and genetically modified organisms and a mythification of public services. Other demands rely on traditional state intervention, as for example when ATTAC (2002b: 26) claims that “State orders can contribute to sustain innovation and emergent industries.”⁸⁷ ATTAC also promotes a protectionist agenda. Even though such word is rarely found in ATTAC’s official statements, Cassen states:

There are no supporters of free trade among us. I am against free trade but I support trade between countries of similar development level. Between France and Germany, there is no problem. But between the European Union and the MERCOSUR, it’s a big mistake. . . . We, the French, cannot have the same trade policy towards Mali and Japan. We must support Mali; we don’t care about Japan. We must thus have preferential tariffs for Mali and strong tariffs for Japan. Politics must be making decisions.⁸⁸

⁸⁷ ATTAC (2002b: 26) gives the example of the high speed train TGV and notes that “Without state funding, an accomplishment like the TGV would never have been done in France.”

⁸⁸ Interview with author, July 31, 2002.

Similarly, ATTAC officially claims that “the priority development of the domestic market is a necessity so as to ensure the protection of new industries or fragile populations. . . . Protectionist policies are guarantors of balanced developments; hyper-specialization is dangerous and must be avoided.”⁸⁹ In an internal document Gérard Duménil and Dominique Plihon (2006), president of ATTAC’s Scientific Council, acknowledge that protectionism can foster rent-seeking behavior and affect workers in developing countries but demand the reinforcement of EU trade barriers so as to protect strategic sectors and prevent massive jobs losses in Europe.

Others demands are more innovative and transcend the nation-state. This is the case of the Tobin Tax that I mentioned earlier but also of the regulation of tax havens and the reform of international institutions. According to ATTAC (2000b), by providing fiscal advantages and insuring banking secrets and legal immunity, tax havens play a key role in the globalization of financial criminal activities. To check this criminality, ATTAC invokes the necessity of an international penal court of humanity, such as the Hague international tribunal, that would be endowed with a supranational jurisdiction addressing economic criminality. In addition and for the time being, ATTAC demands the following: the gathering and diffusion of information on financial crimes; the publication of data on tax havens; that tax havens cooperate with the rest of the international community at the judiciary, administrative, and police levels; sanctions against financial establishments that refuse to cooperate; and the enforcement of existing laws against money laundering regardless of territoriality (ATTAC 2000b: 39-40, 43-44).

⁸⁹ ATTAC, “Les pièges du libre-échange.” August 2005.

ATTAC's demands also aim at a comprehensive reform of international institutions such as the WTO, the IMF, and the World Bank. For example, ATTAC demands a moratorium on all negotiations taking place at the WTO, the suppression of articles threatening national public services and social, environmental, and public health norms, the subordination of the decisions of the WTO's Dispute Settlement Body to international law in terms of human rights, labor conventions, and environmental agreements, the participation of civil society in the elaboration trade policies, the promotion of fair trade, and the interdiction of licensing living organism (ATTAC 2001b: 93-98). Some members of ATTAC's Scientific Council go as far as demanding that the WTO be dismantled and replaced with a World Trade Organization for Development that would give priority to employment and development and be subordinated to the United Nations (Duménil and Plihon 2006).

Like many other opponents of globalization, ATTAC (2002b) also believes that the IMF and the World Bank suffer from a deep democratic deficit. It thus calls for a democratization of these international institutions. It first proposes to reform their decision-making process so that the voting power of members is not determined by their financial contribution. It also demands that women make up half of the governing body of IMF and the World Bank so as to thwart gender inequalities. Second, it claims that the IMF and World Bank bureaucracies should be accountable to national parliaments and civil society (social movements, NGOs, and trade unions). For such purpose, it suggests planned public debates and the creation of delegations composed of parliament and civil society members. Finally, ATTAC proposes that international financial institutions be decentralized into polycentric structures based on regional blocs that would be integrated

to the United Nations structure. The World Bank would thus be dismantled and turned into regional development banks.

3 | THE IMPACT OF THE ANTIGLOBALIZATION MOVEMENT

When discussing the impact of the antiglobalization movement in France, we need first to distinguish movement *success* from movement *impact*. Movement success is relative to the stated goals the movement was pursuing: mobilizing a given constituency, opposing or proposing public policies, shaping public opinion, obtaining collective benefits, etc. Such focus suggests that social movements are homogeneous entities that agree on the goals to be pursued. Furthermore, it overstresses purposeful action at the expense of unintended consequences (Giugni 1999: xx-xxi). In contrast, looking at the impact of social movements entails focusing on socio-political changes brought about by social movements whether or not they were intended. It implies imposing from the outside an assessment of the movement's action whether or not it is shared by movement actors (cf. Giugni 1999: xxi). The difficulty of this task is obviously to isolate the impact of social movements from circumstantial and structural factors (Amenta and Young 1999: 36-39). It is safer to claim that a given social movement contributed to a given outcome than assert that it is *the* cause behind it.

For example, French public opinion has been holding an increasingly negative perception of globalization (see Table 4.1). Although this trend matches the creation of ATTAC and numerous mobilizations against international institutions like the WTO, the

G8, the IMF, and the World Bank, it is impossible to assert that it stems from the emergence of the antiglobalization movement.

Table 4.1: Public Perception of Globalization in France (1998-2005)

Percentage believing that globalization is a <i>bad thing</i> for...			
	1998	2003	2005
French consumers	29	42	47
French companies	25	44	47
Someone like you	34	44	50
Country's public services	NA	43	51
Population's standard of living	36	50	62
French employees	46	58	64
Jobs in France	43	66	65

Sources: 1998: CSA-*Challenges-France Inter*, October 1998; 2003: CSA-*L'Humanité*, 27-28 August 2003; 2005: CSA *Challenges*, 7-8 December 2005. Adapted from Ivaldi (2006: 16).

Similarly, the fact that WTO negotiations failed in Seattle in 1999 and in other, subsequent ministerial meetings is difficult to attribute to the antiglobalization movement. Disagreements among participating countries were already so deep (on issues like agricultural subsidies, intellectual property, labor standards, etc.) that the negotiations would have probably failed even without protests. Besides, the negotiations failed in Qatar in 2001 and in Hong Kong in 2005 even though there were substantially less protests than in Seattle in 1999 or in Cancun in 2003. But whether or not the antiglobalization movement is the actual cause of failed trade talks it must claim credit for these failures so as to justify the amount of resources activists and organizations invest in these mobilizations, boost its aura among by-standers, and convince other socio-political actors to join its struggle. Effectively claiming credit for social and political change is a resource for future mobilizations and struggles (Meyer 2002).

I argue that the antiglobalization movement had an impact not so much on public policies (e.g., protectionist trade policy, social compensation for losers of globalization, etc.) as on the terms of the public debate. It brought about the emergence of a new political identity and, above all, made some issues more salient while claiming ownership on them.

3.1. The Emergence of a New Political Identity

New collective identities, ideas, and other cultural innovations are among the main effects of social movements (Amenta and Young 1999: 34-35, Rochon 1998). As a type of collective identity, political identities draw boundaries between people (us vs. them) and thereby give meaning and shape relations between socio-political actors. The French antiglobalization movement brought about the emergence of a new political identity that activists call “alterglobalist” (*altermondialiste*). This identity is reminiscent of socialist internationalism insofar as it is characterized by an active support for a form of globalization that would provide an alternative to free trade and neoliberalism (*altermondialisation*). This identity was consciously articulated in late 2001, when ATTAC activists were trying to find a positive spin that would avoid the negative connotation of the label “antiglobalization.”⁹⁰

The new identity quickly spread within the networks constituting the antiglobalization movement and is today claimed by most leftwing socio-political actors even though some of them distinguish themselves from the antiglobalization movement.

⁹⁰ I attended several meetings during which the new name was openly discussed in such strategic terms. In the United States, the identity shift was not an issue because the movement very quickly defined itself in positive terms as the “movement for global justice.”

Some candidates running for office, such as Trotskyite LCR candidate Olivier Besancenot in the 2002 presidential election, even depict themselves as *the* “alterglobalist” candidate. The new identity was also picked up, and thereby ratified, by the French press (see Figure 4.3).

Figure 4.3: The Symbolic Redefinition of the Opposition to Globalization

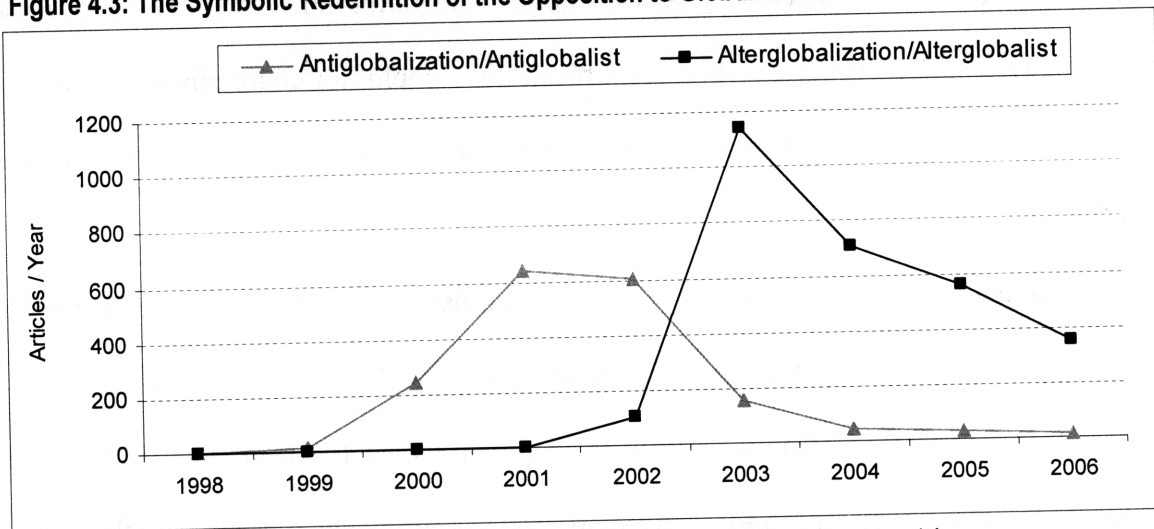

Sources: *Le Monde* and *L'Humanité*, Electronic Archives; *Libération* data based on Biblio Branchée.

Notes: 1/ Total numbers of articles per year that include “antiglobalization,” “antiglobalist,” “alterglobalization,” or “alterglobalist,” in the three leading newspapers of the French left, *Le Monde*, *L'Humanité*, and *Libération*.

2/ In French, “antiglobalization” = antimondialisation; “antiglobalist” = antimondialiste; “alterglobalization” = altermondialisation; and “alterglobalist” = altermondialiste.

3/ Insofar as some articles refer to “antiglobalization” as well as “antiglobalist,” or “alterglobalization” as well as “alterglobalist,” they may be counted twice. This double counting affects the total number of articles but not the overall trend because the particular label (anti or alter) does not affect the likelihood that it will be repeated in a given article.

This new political identity allowed activists to clearly distinguish themselves from nationalists and far-right opponents of globalization. By providing a positive twist on the opposition to globalization, this identity also reinforced the symbolic glue that the ad hoc alliance underlying the antiglobalization movement needed (cf. Ansell 1997).

3.2. Shaping the Public Debate

The antiglobalization movement had a huge impact on the public debate. This impact is visible first in the institutionalization of the “Politics against the Global Market” frame that I described in section 1. Even though traditional leftwing and labor actors had been denouncing the consequences of global economic integration since the 1970s, they had never focused solely on these issues. As a result, they could not claim any ownership on them. The antiglobalization movement, in contrast, turned these issues into its rallying cry and flagship.

The case of the Tobin Tax provides a good illustration of this process. The idea of imposing a tax on currency exchange and, thereby, on capital mobility was first formulated by late Nobel Laureate and Yale economics professor James Tobin in 1972. However, it remained an arcane proposition for many years and was completely absent from the French public debate until the 1995 presidential election, when the Socialist Party included it in its program. The PS lost the election and the Tobin Tax remained in the shadow. It is only in 1998, with the creation of ATTAC (whose name first meant Association for a Tobin Tax for the Aid of Citizens), that this issue gained some public visibility and began to be widely debated (see Figure 4.4). In September 2001, 71 percent of the French were in favor of the implementation of the Tobin Tax.⁹¹ As a result, ATTAC came to own the issue of the Tobin Tax. The interest that other socio-political actors displayed appeared as strategic

⁹¹ Sondages CSA, “Les Français et la taxe Tobin,” retrieved on September 17, 2001, from <http://www.csa-tmo.fr/fra/dataset/data2001/opi20010912b.htm>.

opportunism or mere rhetoric even when, as in the case of the PS, they had raised this issue before ATTAC was even created.⁹²

Figure 4.4: The Rise of the Tobin Tax in Leading Leftwing Newspapers

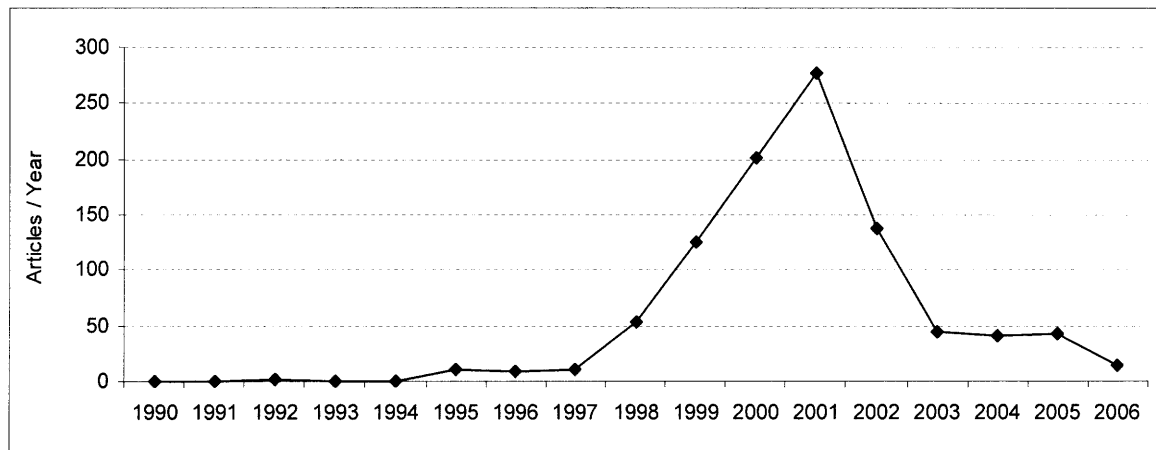

Sources: *Le Monde* and *L'Humanité*, Electronic Archives; *Libération* data based on Biblio Branchée.

This example suggests that ATTAC and, more generally, the antiglobalization movement owe their ability to mobilize people not so much to their ideas, which were already held by competing socio-political actors, as to their critique of established leftwing and labor organizations. In spite of common values and shared goals, the latter were systematically targeted by the antiglobalization movement as agents of neoliberal globalization and hierarchical, undemocratic organizations. The organizational form of the leading organizations of the antiglobalization movement, with its emphasis on participatory structures, became part of their collective identity and of the collective action frame they used to mobilize resources (cf. Clemens 1996). The impact of the

⁹² However, as Figure 4.4 indicates, the Tobin Tax has lost its aura. This is partly due to a refocus of ATTAC-France—in contrast to ATTAC organizations in other countries—on national rather global demands over the last few years (see Ugglá 2006). Today ATTAC invokes the Tobin Tax as a source of funding not only for developing countries but also for public works that would reduce unemployment in Europe (see, for example, ATTAC, “Le CPE est un symbole du néolibéralisme,” 2006).

antiglobalization movement on the public debate goes thus beyond policy issues and includes the very way interests are organized and represented.

3.3. The Mobilization of a Wide Support

The antiglobalization movement managed to mobilize a wide support. For example, ATTAC's membership grew exponentially during the three years that followed its foundation to reach almost 30,000 members by 2001.⁹³ That same year 125 deputies at the National Assembly were members of ATTAC and there was also an ATTAC coordination at the European parliament.⁹⁴ These deputies were an important external resource for ATTAC, as they regularly relayed its analysis and claims. Support for the antiglobalization movement in France is also visible in strong participation in protests against the G8 in May 2003 in Evian and against the WTO in the August 2003 Larzac meeting. Similarly, more than 50,000 people attended the workshops and meetings of the 2003 European Social Forum in Paris while 80,000 marched to conclude the event.

In addition to ATTAC's rise and the protest events mentioned above, the small parties and trade unions most active in the French antiglobalization movement—such as the LCR and SUD—directly compete with established leftwing and labor organizations through elections. This was most obvious in the 2002 and 2007 presidential elections,

⁹³ However, its membership has been decreasing since 2004 and ATTAC is today increasingly appearing as a traditional organization itself to the eyes of the younger generation of activists that did not participate in the mobilizations of the late 1990s. See S. Zappi, "Attac en perte d'influence chez les altermondialistes," *Le Monde*, June 17, 2006. Furthermore, the deep crisis that ATTAC experienced in 2006, as internal elections suffered from fraud, undermined its credibility as a democratic alternative to mainstream organizations.

⁹⁴ In spite of tensions between ATTAC and the PS, socialist deputies dominated the ATTAC coordination at the National Assembly and the European parliament.

when the LCR got respectively 4.2 and 4 percent of the vote while the PCF obtained its lowest scores ever with 3.4 and 1.9 percent. In public postal and communication services (PTT), SUD challenged the CFDT and the CGT in administrative board elections (see Table 4.2).

Table 4.2: Results of Administrative Board Elections (% of vote)

		1991 ^a	1995	2000
Postal services (<i>La Poste</i>)	CGT	37	39.5	34.5
	CFDT	26	17.3	18.3
	SUD-PTT	-	14.4	21
Communication services (<i>France Télécom</i>)	CGT	35.5	32	28
	CFDT	33	18.1	20.5
	SUD-PTT	-	26.7	27.4

Source: Simon Macaire, "Workforce elections held at La Poste and France Télécom," ID FR0011106F, European Industrial Relations Observatory On-Line, November 28, 2000. [<http://www.eiro.eurofound.eu.int/2000/11/feature/fr0011106f.html>].

Note: (a) SUD-PTT did not have a representative status in 1991 and, thus, could not present candidates for administrative board elections. Its status was modified in 1994.

4 | CONCLUSION

The antiglobalization movement that emerged in the late 1990s in France was constituted by a variety of actors that altered the demographic environment of labor organizations. Depending on the institutional arena in which these actors evolved, they competed with the CFDT and the CGT on different grounds. Whereas ATTAC, with its Scientific Council and intellectual production, focused on the terms of the public debate, small radical unions like SUD, that operate in the industrial relations arena, grew at the expense of the CFDT and the CGT.

The rise of the antiglobalization movement involved thus a competitive challenge. Since its effect on organizational maintenance was small compared with that of the

structural challenge, it did not bring about a critical juncture that could have led labor organizations to depart from their path again. However, as I will explain in chapters 5 and 6, it did induce them to make explicit certain assumptions and invest additional resources in activities, events, and alliances. Thereby, the antiglobalization movement unwittingly consolidated the respective paths upon which the CFDT and the CGT had embarked when they faced the structural challenge.

The Path to Adaptation: The Case of the CFDT

The French Democratic Labor Confederation (Confédération Française Démocratique du Travail, CFDT) was until recently France's largest trade union organization.⁹⁵ It embodies the adaptation strategy. It believes that globalization is a fact that requires adaptation rather than a neoliberal project that must be resisted. It favors trade liberalization and a managed globalization and calls for social concertation with employers as a way to develop policies aimed at industrial upgrading to compete in the global economy. Although it advocates the enforcement of labor standards and the reform on international institutions like the IMF, the World Bank, and the WTO, it diverges from the antiglobalization movement. This chapter lays out the particular features of this response to globalization and explains its formation over time.

The CFDT's response to globalization does not reflect its social composition. Whereas most French trade unions recruit a disproportionate number of members from the public sector which is sheltered from the effects of globalization, in 2006 61 percent of the

⁹⁵ A recent study (Andolfatto and Labbé 2007) estimates that the CGT, with 525,000 members, has become the largest French trade union organization anew. The CFDT follows with 450,000 members. These estimates are substantially lower than the official numbers reported by unions (710,000 for the CGT and 800,000 for the CFDT).

CFDT's membership worked in the private sector. The CFDT should thus be more likely to be opposed rather than favorable to trade liberalization. At the same time, however, a substantial share of its private sector members works in the service sector (health, retail, etc.) and is not directly exposed to trade and foreign competition. But even its traditional workers' federations that have been exposed to globalization for several decades—such as metalworkers (which includes steel and electronics) and textile-apparel workers—embrace the adaptation strategy of their confederation. Therefore, we need to look beyond the social composition of the CFDT to account for its response to globalization.

Some may argue that the response of the CFDT is simply congruent with its reformist and pro-European integration stance and fits the evolution of European social democratic parties (cf. Marks and Wilson 2000). Nonetheless, the CFDT's response to globalization is not as predictable as it may seem at first glance. The CFDT has, indeed, always been pro-European,⁹⁶ but throughout the 1970s it was also opposed to capitalism and explicitly rejected free trade and the new international division of labor in the name of democratic socialism and an alternative model of development. The arguments and demands it put forward at the time are in several respects quite similar to those we can find today within wide segments of the antiglobalization movement and the resistance strategy.⁹⁷ Therefore, in the early 1970s it would have been difficult to predict that the CFDT would adopt the adaptation strategy in the 1990s.

⁹⁶ Nonetheless, according to Branciard and Venturini (1986: 9), in the late 1950s the CFTC faction that would found the CFDT in 1964 ("Reconstruction") criticized the common market.

⁹⁷ A crucial difference, however, is that the radical break with capitalism that was advocated in the 1970s implied a revolution rather than resistance.

Broadly speaking, we can distinguish two phases in the CFDT's response to globalization. Each phase is associated with a wider pattern of resource mobilization. The first phase spanned from the late 1960s to the late 1970s and implied an offensive, class-based anticapitalist posture that opposed globalization in the name of an alternative model of growth and development. This radical strategy, as I call it, advocated the socialization of the means of production, the promotion of national industries, and drew upon the project of a New International Economic Order (NIEO) promoted by the Group of 77 and the non-aligned countries at the United Nations. Its perspective was close to third-worldism, that is, a leftwing interpretation of the North-South relations and the world economy that denounced imperialism and supported national liberation movements. This response to globalization was intertwined with a pattern of resource mobilization based on class politics insofar as it interpreted social reality and intervened in public affairs through the prism of politicized working-class identities, class struggle, and anticapitalism.

During the 1980s, the CFDT underwent a transition that involved a gradual acceptance of the market economy and the abandonment of socialism. It increasingly invested its hopes in the European Economic Community as an alternative to what it depicted as an outdated national Fordist model of regulation. This transition ended in the late 1980s and opened the way for a second phase characterized by the adaptation strategy that I introduced above. The CFDT had opposed globalization insofar as it opposed capitalism. Once its rejection of capitalism faded, so did its opposition to globalization.

In order to understand the CFDT's current response to globalization we need thus to trace its evolution over the last thirty years and look at its concrete experience while it tried to address the problems and challenges it encountered. The successive decisions that

the CFDT made to address the latter added up to gradually form a coherent organizational strategy and generate a distinctive path that departed from the previous trajectory of the CFDT.

This chapter analyzes the CFDT's current response to globalization as the product of the structural challenge of late 1970s and 1980s. This challenge implied a situation of organizational failure that brought about a critical juncture. The CFDT's reaction to this juncture stemmed from internal struggles shaped by the organizational repertoire and linkages of the CFDT. Subsequently, in the late 1990s the rise of the antiglobalization movement represented a competitive challenge that reinforced the path that the CFDT had taken during the critical juncture.

This chapter first presents the repertoire and linkages of the CFDT. Second, it presents the CFDT's response to globalization in the 1970s, at the peak of class politics. In addition to the confederal perspective, I discuss the case of the textile-apparel workers' federation; as an organization operating in a labor-intensive sector highly exposed to foreign competition, it represents a critical case for economic theories claiming that organizational trade preferences reflect the factor-endowment of their members. Third, I describe how the CFDT experienced organizational failure. Four, I explain how it responded to the structural challenge through a process of what Streeck and Thelen (2005) call conversion and trace the three central mechanisms that structured this process, namely, bricolage, identity shift, and closure. Five, I trace the unintended consequences of conversion and show how they contributed to the rise of the antiglobalization movement. And finally, I present the CFDT's current response to globalization as part of a new strategy of resource mobilization that no longer relies on class politics.

1 | THE ORGANIZATIONAL CHARACTERISTICS OF THE CFDT

The CFDT was founded in 1964. Although it is a secular offshoot of a Christian trade union, the French Confederation of Christian Workers (CFTC), that rejected class struggle and stressed instead the community of interests between workers and capitalists, it participated in class politics. It relied on blue-collar working-class identities, socialist ideological appeals and beliefs emphasizing class struggle, and informal linkages with leftwing political parties. In terms of social constituency, it built upon a strong blue-collar base that the CFTC had developed in the 1930s and 1950s. In 1976, the year when the CFDT peaked with 750,000 members, the metalworkers' federation was by far its most important federation with 18.8 percent of the total membership (Andolfatto 2001: 70).⁹⁸ At the time, the social base of the CFDT was primarily located in industry and agriculture, where more than 47 percent of its membership worked (Groux and Mouriaux 1989: 75).

The origins and historical trajectory of the CFDT produced particular sets of resources—a repertoire and linkages—that it could use to intervene in the industrial relations arena and public debates. These sets of resources represent the initial conditions under which the CFDT approached the situation of organizational failure it faced in the late 1970s. I present each set in turn below.

⁹⁸ Other leading federations included chemical workers (9 percent of total membership), agricultural workers (8.9 percent), health workers (8.6 percent), public education teachers (8.3 percent), transport-equipment workers (6.9 percent), postal workers (5.4 percent), and textile-apparel workers (4.9 percent) (Andolfatto 2001: 70).

1.1. The Organizational Repertoire of the CFDT

The CFDT sits on three cleavages that shaped French politics: the labor-capital cleavage, the state-church cleavage, and the reform-revolution cleavage. Each cleavage left its imprint on the CFDT's organizational repertoire or tool-kit, that is, the relatively stable cultural materials to which members of the CFDT turn to define their collective identity as well as make sense of the world and engage in it.

The organizational repertoire of the CFDT draws from three different traditions: the Christian-democratic tradition,⁹⁹ social-democracy and English socialism as expressed in Fabianism, and revolutionary anarcho-trade unionism (Rosanvallon 1980: 9-10). These traditions underlay a denunciation of the market with strong moral—as opposed to just political and economic—overtones but also fed a forceful critique of the state that departed from the statist Jacobin tradition of the French left. They involved anti-authoritarianism and a refusal of rigid hierarchies, a belief in local and decentralized forms of collective action (e.g., subsidiarity), and faith in the self-organizing capacity of civil society.¹⁰⁰ One of the logical consequences of this antistatism was a preference for contractual relations between employers and workers rather than state intervention through the law.

These traditions also implied—and in a manner congruent with the state-Church cleavage and the reform-revolution cleavage—a deep suspicion toward communism. Hence the CFDT's insistence on *democratic* socialism and *democratic* planning as an

⁹⁹ Tixier (1992: 243-260) argues that the Christian heritage of the CFDT also stemmed from the influence that the “personalist” thought of Emmanuel Mounier and his review *Esprit* had on Paul Vignaux and the “Reconstruction” group. On social Catholicism in France, see Berger (1987) and Hazareesingh (1994).

¹⁰⁰ For a presentation of the antistatist socialist tradition in France, see Canto-Sperber (2003). For an analysis of the policies that this tradition inspired during the Rocard government (1988-91), see Levy (1999).

alternative to the statist Leninist model promoted by the communist left. Furthermore, in contrast to the latter but in accordance with its Christian roots, the CFDT stressed the moral needs of individuals. This meant serious attention to the cultural consequences of capitalism, particularly materialism and alienation, and the claim that real social change could not happen without cultural change (Groux and Mouriaux 1989: 164-165). In other words, social progress required not only quantitative but also qualitative demands.

The organizational repertoire of the CFDT was structured around three axes: *antistatism* (contractual relations, self-organizing capacity of civil society, subsidiarity), *anticommunism* (primacy of democratic liberties and individual rights), and a *Christian ethics* (moral critique of the market underlying qualitative demands, humanism). The respective influence of each axis on the positions and practices of the CFDT varies in time. For example, since the fall of the Berlin Wall and the collapse of the USSR anticommunism has lost most of its relevance even though the reform-revolution cleavage remains. Organizational repertoires are thus not static or frozen; they are instead “dynamically reproduced” (cf. Thelen 1999) through a recasting of their core symbols and collective action frames (cf. Benford 1997, Snow and Benford 1988, Snow et al 1986, Tarrow 1992).

The organizational repertoire of the CFDT was hence quite heterogeneous. Such heterogeneity entails potential contradictions and tensions, but also implies a wide array of dormant or latent resources that can turn into a substantial advantage (cf. Crouch 2005, Crouch and Farrell 2004: 18). Heterogeneity increases the range of potential interpretations and recombinations and, thereby, the likelihood of innovation and the possibility of departing from a given organizational pathway. Put differently, the fact that the CFDT had

a heterogeneous organizational repertoire meant that it was relatively flexible and had more resources to adjust to environmental changes.¹⁰¹

1.2. The Organizational Linkages of the CFDT

Organizational linkages both enable and constrain collective action by shaping the nature and flow of resources to which organizations have access. They are characterized by their strength and breadth (Aveni 1978).

In the late 1970s, when organizational failure began to become manifest, the CFDT had multiple weak linkages. It competed fiercely with other trade unions to mobilize workers and increase its membership and could not count on their support. Its relation to political parties was more ambivalent. Throughout the 1960s and 1970s, the CFDT had informal relations with leftwing parties, particularly the small Unified Socialist Party (PSU) and then the growing new Socialist Party (PS). However, after failed attempts at influencing these parties in 1973 and 1974, the issue of party-union relations became very divisive inside the CFDT and the confederal leadership started gradually to envision alternative ways of mobilizing resources and intervening in public affairs. Although several of its leading members were also affiliated with the PSU or the PS, the CFDT had only informal and irregular relations with political parties. In other words, it had a few weak linkages. Things improved a bit in the early 1980s, when several leading members of

¹⁰¹ It does not follow, however, that the resulting innovation will succeed in solving the maintenance crisis. Innovations do not always generate the desired outcome.

the CFDT participated in Pierre Mauroy's socialist government, but the honeymoon ended abruptly in 1983 when the government implemented an austerity policy.

Since the events of May 1968, the CFDT had also cultivated linkages with social movements (Georgi 2004). Its critique of hierarchy and domination as well as productivism facilitated encounters and connections with the feminist, environmentalist, and pacifist movements. It relayed several demands of these movements and tried to articulate more stable relations with them as in the 1973 Union of Popular Forces initiative. However, because of the exclusionary nature of the French state and the salience of the class cleavage, these movements never managed to build a large constituency and mobilize wide segments of society (Kriesi et al 1995). Furthermore, the suspicion of the confederal leadership toward the numerous Trotskyist and Maoist militants active in these movements prevented the development of any substantial or formal relation. Once more, the CFDT had multiple but weak linkages.

Finally, in the late 1970s the CFDT secretly developed relations with leaders of the French national association of employers, the CNPF (Hamon and Rotman 1984). The defeat of the left in the 1978 legislative election consolidated this effort of finding ways of improving the workers' fate without relying on politics. However, in the late 1970s, when the CFDT was still officially a proponent of self-management socialism, such encounters could not be made public, for they would have undermined the legitimacy of the confederal leadership. The participation of leading members of the CFDT in the socialist government in 1981-83 did not contribute to the emergence of formal relations. Therefore, one could say that in the case of employers-union relations, the CFDT had a single weak linkage.

Overall, the organizational linkages of the CFDT were characterized by low strength (generally weak linkages) and relative breadth (multiple sources of resources). It did not develop formal relations with other organizations that would have entailed a substantial and stable flow of resources. Linkages remained based on personal relations and occasional organizational support. On the other hand, the multiplicity or extensiveness of these linkages provided a diversified source of resources to the CFDT that fostered autonomy and flexibility. Herbert Kitschelt (1994) has explained that tight party-union relations diminish the capacity of social democratic parties to adjust to environmental changes. The same logic can apply the other way around. The fact that the CFDT did not manage to build formal relations with parties allowed it to preserve its autonomy and, thereby, capacity to adjust to environmental changes.

2 | RESPONSES TO GLOBALIZATION IN THE ERA OF CLASS POLITICS: THE RADICAL STRATEGY

The organizational repertoire and linkages of the CFDT shaped its response to globalization in the 1970s. The CFDT saw changes in the international economy through the prism of an antistatist and class-based rejection of capitalism. Its strategy was radical not so much because it opposed free trade, multinational firms, and global economic integration, as because it advocated a break with capitalism. This position was sustained by a consensus of opinion inside the CFDT, even though there were strong internal disagreements about which alliances might contribute to realize such a perspective. This

section lays out the CFDT's interpretation of the international economy, demands, and alliances and tactics.

2.1. Interpreting the International Economy

One of the starting points of the CFDT's reflection was the acknowledgement that a growing number of domestic issues had international ramifications. A 1972 special edition of its internal bulletin is worth quoting at length:

Decisions made at the international level have direct consequences on our everyday lives although we don't always perceive their reach: Our trade, our job, often depend on configurations that go beyond French borders. Here are some examples. The German shoe maker Salamander decided to lay off workers in its German factories while it hired workers in its factory of Romans (Drôme), because in this sector German wages are higher than French wages. The direction of the American firm Singer decided, from its headquarters in Michigan, to "restructure" its European operations. The result: an important part of the personnel at "Control's – France", in Schirmek (Alsace), was fired overnight.

What we eat, what we buy, is also international. We drink Coca-Cola (American), whisky (Scottish). We eat Nestlé (Switzerland) or Côte d'or chocolate (Belgium). We buy a Fiat (Italy) or a Honda (Japan) and fill it with gas from an American or Anglo-Dutch company. We watch TV on a Philips (Netherlands) set and our camera is Japanese (Yashika, Minolta, etc.). We wash, we dress with products made by large international trusts.

Thus, without us always taking notice, our life is "framed" [*encadrée*], even determined by the action of these large international groups.¹⁰²

The CFDT's critique of globalization in the 1970s was similar to the one articulated today by the antiglobalization movement: it argued that globalization leads countries to engage in a race to the bottom at the expense of social and environmental standards, increases

¹⁰² CFDT, "L'action internationale de la CFDT: C'est notre affaire à tous!," *Syndicalisme*, December 28, 1972, p. 5-6

domestic and global inequalities, and undermines democracy and sovereignty.¹⁰³ At the origins of this process are the interests of capitalists as they try to maximize profit by escaping domestic constraints through an expansion of their operations beyond national borders.¹⁰⁴

According to the CFDT, multinational corporations (MNCs) are the key actors of this system. They play one country against another in their search for lower wages and higher profits, they plunder the natural resources of the third world, and they locate their headquarters in countries that provide fiscal advantages and guarantee financial secrecy.¹⁰⁵ Furthermore, insofar as low wages are an important element in the international competition, MNCs oppose any measure that would foster a harmonization of wages and working conditions among countries; their business strategy relies on the maintenance of such disparities.¹⁰⁶ In contrast to what mainstream liberal economists argue, the CFDT claimed that foreign direct investment in developing countries benefited only MNCs and financial groups. An important report of the textile-apparel workers' federation of the CFDT (Hacuitex) explained:

The redeployment of textile is often presented as indispensable to allow developing countries to industrialize and thus take-off. In fact, it is necessary to note that capitalists impose on these countries and their populations choices guided only by the profits of MNCs Actually, the only beneficiaries of foreign investment are the firms that make the investment. . . . An investment [in a developing country] allows MNCs to make socks at 80¢ a pair which afterward can be sold at the price of the European market. The investment does not benefit the country where the

¹⁰³ However, actors did not refer to “globalization” as such but to “economic internationalization.” The word “globalization” first appeared in internal documents of the CFDT in 1983.

¹⁰⁴ CFDT, “Les réalités actuelles du capitalisme international,” Département international, November 1972, p. 6-7.

¹⁰⁵ CFDT, “L’action internationale de la CFDT: C’est notre affaire à tous!,” p. 6.

¹⁰⁶ CFDT, “Les réalités actuelles du capitalisme international,” p. 18. However, this same report acknowledges that MNCs pay higher wages than local firms.

production was carried out and the European consumer pays his socks the same price as before. The only beneficiary is the trust.¹⁰⁷

According to the CFDT, developing countries do not have much room to implement changes that would allow them to benefit from foreign investment. If a country attempts to exercise its sovereignty and act in an independent way or if trade unions mobilize an important political support and gather momentum, MNCs can decide overnight to close their factories, leave the country, and establish their operations somewhere else without anyone being able to stop them. This dynamic has direct consequences on employment, wages, and working conditions.¹⁰⁸

In addition to MNCs, the CFDT argued, the capitalist governments of advanced industrial countries prevent developing countries from building an industrial base that would foster their “take-off” and, instead, boil them down to providers of raw materials. The future seemed bleak for developing countries, as the CFDT contended that the trend toward a diminution of the price of raw materials would continue whereas the price of finished goods produced by advanced industrial countries would keep increasing. As a result, third-world countries’ exports would generate fewer and fewer revenues and the possibility of productive investments would decrease.¹⁰⁹ If developing countries managed to escape specialization in raw material exports, they would produce cheap manufactured goods that would not yield major profits. According to the CFDT, the American policy of

¹⁰⁷ Hacuitex-CFDT, “Le livre blanc pour le maintien et le développement des industries textiles, habillement et cuirs en France,” October 1978, p. 13, 18.

¹⁰⁸ CFDT, “L’action internationale de la CFDT: C’est notre affaire à tous!,” p. 6.

¹⁰⁹ CFDT, “Les réalités actuelles du capitalisme international,” p. 21.

“Trade, not aid” consolidated this pattern of domination.¹¹⁰ The labor confederation claimed that public aid to developing countries was too small and too often delivered in the form of loans that increase the debt of these countries. In line with Marxist claims about center-periphery relations and underdevelopment,¹¹¹ the CFDT concluded pessimistically that “all these mechanisms contribute to perpetuate and deepen the domination of capitalist countries over those of the third-world. It is an aspect of imperialism.”¹¹²

2.2. Demands

What solutions did the CFDT advocate to solve the problems associated with global economic integration? Although it acknowledged that certain industrial sectors, such as textile-apparel, had seen their workforce dwindle rapidly since the late 1960s and worried that France was too dependent on other countries for energy, technology, and certain manufactured goods, the CFDT did not believe that closing down French borders would benefit workers. Even its textile-apparel workers’ federation ruled out protectionism. It blamed the government’s trade policy for fostering the relocation of production in low-wage countries and demanded public measures to maintain jobs in the textile-apparel industry. At the same time, it also argued that “The temporary restriction of imports, logic in itself, will be without effect. It does not modify the general policy of the liberal

¹¹⁰ CFDT, “L’action internationale de la CFDT: C’est notre affaire à tous!,” p. 7.

¹¹¹ For reviews of academic and political debates about development and underdevelopment in the 1970s, see Cox (1979) and Doyle (1983).

¹¹² CFDT, “L’action internationale de la CFDT: C’est notre affaire à tous!,” p. 7.

economy based on profits and international capitalist competition.”¹¹³ Similarly, it rejected the Multifiber Agreement (MFA) on grounds that it essentially served capitalist interests rather than preserving employment.¹¹⁴

The CFDT upheld this position in great part because it simply did not believe that offshoring and imports of manufactured goods from developing countries lay behind job losses. It pointed out that these imports represented a tiny portion of total imports and that they were concentrated in a limited number of products and sectors. It remarked that, as far as one could tell, job losses due to the competition of developing countries were being offset by job creation related to exports.¹¹⁵ Moreover, its textile-apparel workers’ federation had noted in the past that job losses in this industry were due to a large extent to increasing automation and productivity gains.¹¹⁶ In fact, the CFDT refused to see the relation between globalization and international employment as a zero-sum game and blamed above all capitalist interests. In a speech he delivered at a United Nations conference in Vienna in October 1978, CFDT Secretary General Edmond Maire said:

It is wrong to present world employment as a pie to share, any job created somewhere bringing about the loss of a job somewhere else . . . It is wrong to present the decline of many firms and branches as resulting from the competition of developing countries when it is business interests that lead to the relocation of

¹¹³ Hacuitex-CFDT, “Document sur le commerce mondial, habillement, cuirs, textile,” April 1977, p. 3.

¹¹⁴ Hacuitex-CFDT, “Le livre blanc pour le maintien et le développement des industries textiles, habillement et cuirs en France,” p. 20. The MFA was a departure from the General Agreement on Tariffs and Trade (GATT) in that it allowed import-quotas and safeguard measures in the textile and apparel industry. It was enforced from 1974 to 1994 and then replaced with a similar agreement negotiated under the WTO, the WTO Agreement on Textile and Clothing (ATC), which was enforced from 1994 to 2004. See http://www.wto.org/english/tratop_e/texti_e/textintro_e.htm.

¹¹⁵ CFDT, “Nouveau type de développement et nouvel ordre économique international,” Bureau national, sessions of June 14-16, 1978, p. 19 (this report was turned into a note by the International Sector of the CFDT and distributed to militants). However, in this same report the CFDT also acknowledged that the jobs created were not as the ones lost in terms of skills, salary, etc.

¹¹⁶ Hacuitex-CFDT, “Solidarité internationale des luttes,” International Report presented by the Federal Council, 37th Federal Congress, May 20-23, 1971, p. 32-33.

labor-intensive industries toward developing countries and reserve growth sectors for developed countries, ensuring thereby the continuity of unequal exchange and their domination.¹¹⁷

Instead of defending their national economies and falling in the trap of division, the logic went, workers of the world should unite. This class-against-class perspective was already present in the early 1970s. For example, in 1971 the textile-apparel workers' federation refused to engage in social concertation on grounds that horizontal interests (class-based) prevailed over vertical ones (industry-based):

The interests of workers of all countries are not opposed. It is the baited struggle between capitalist groups for the conquest of new markets and higher profits that provokes apparent antagonisms between the textile industries of different countries. Therefore, we affirm that in no way can there be a community of views between bosses and workers and a possibility of common action to address these problems. . . . The struggle for development in all the countries of the world, including our own, is necessarily an anticapitalist struggle.¹¹⁸

Similarly, a year later the confederal International Department of the CFDT claimed:

Capitalism is *one* throughout the world. The capitalist exploitation and alienation that mark French and German workers, and those of all industrialized countries, are the same as those that strike workers in Senegal and Argentina. . . . They are all victims of the same system that monopolizes the wealth of the world, exploits and alienates men for the maximum profit and power of a few.¹¹⁹

The CFDT's position on globalization was driven by a class-based anticapitalist perspective. It advocated the construction of a united, democratic, socialist Europe based on the social ownership of means of production and exchange, democratic planning, and

¹¹⁷ Edmond Maire, Speech delivered at the United Nations conference "The attitude of trade unions in developed countries toward the New International Economic Order," Vienna, Austria, October 23, 1978, p. 4.

¹¹⁸ Hacuitex-CFDT, "Solidarité internationale des lutes," p. 34-35. Along the same line, in 1978 Hacuitex-CFDT stated: "Our struggle should not be considered as nationalist but as an international class struggle opposed to the international division of labor and denouncing imperialism." Hacuitex-CFDT, "Le livre blanc pour le maintien et le développement des industries textiles, habillement et cuirs en France," p. 25.

¹¹⁹ CFDT, "Les réalités actuelles du capitalisme international," p. 26. Emphasis in original.

self-management, and demanded a transformation of international trade so as to allow developing countries to emancipate themselves from the domination of advanced industrial countries.¹²⁰ However, beyond the rhetoric, the *concrete* demands that the CFDT put forward actually had moderate implications.

For example, even though in the 1970s the textile-apparel workers' federation was among the most radical federations of the CFDT, it demanded that layoffs be anticipated and that professional training be provided to workers to facilitate their transition to new jobs.¹²¹ Similarly, it called for an alternative industrial policy that would defend domestic employment but, once spelled out, this policy boiled down to the valorization of employment in the textile-apparel industry through wage and pension increase, a professional status reform, and a reduction of working time (35-hour week, 5th week of paid vacation, and early retirement).¹²² While such policies could arguably improve the lives of textile and apparel workers, it is hard to see how they would increase or even sustain employment. Its anticapitalist perspective and critique of the international division of labor led the CFDT to rule out policies that would foster industrial upgrading so as to compete with foreign competition through higher value-added products. The only measure that it advocated that could perhaps (temporarily) save jobs was worker self-management.¹²³

¹²⁰ CFDT, "L'action internationale de la CFDT: C'est notre affaire à tous!," p. 12.

¹²¹ Hacuitex-CFDT, "Solidarité internationale des lutes," p. 34.

¹²² Hacuitex-CFDT, "Document sur le commerce mondial, habillement, cuirs, textile," p. 4, and "Le livre blanc pour le maintien et le développement des industries textiles, habillement et cuirs en France," p. 24-26.

¹²³ Hacuitex-CFDT, "Le livre blanc pour le maintien et le développement des industries textiles, habillement et cuirs en France," p. 24. Inspired by the revolutionary anarcho-trade unionist tradition and the Yugoslavian experience, self-management originally referred to direct control of the means of production by workers but was expanded to a more encompassing ideal questioning all forms of hierarchy and domination (Reynaud 1975: 219-220, Tixier 1992: 285-286). The only relatively successful example that the CFDT could invoke to

Although it refused zero-sum conceptions of globalization, the CFDT noted that its defense of employment in advanced industrial countries could undermine job creation in developing countries. It thought that the only way to solve this contradiction was to endorse an alternative model of development that would depart from productivism, the international division of labor, and unequal international trade. To address this issue, it drew upon the non-aligned countries' proposition of a New International Economic Order (NIEO) that was voted at the United Nations General Assembly on May 1st 1974. According to the CFDT, two themes of the NIEO stood out: the control of MNCs and the opening up of advanced industrial countries to developing countries' exports.¹²⁴ The CFDT believed that the first theme could lead to a convergence of struggles between Northern and Southern trade unions through work councils and the implementation of codes of conduct.¹²⁵

The second theme, however, was more sensitive. One of the core points of the NIEO was the principle of "non-reciprocity" in trade, that is, the unilateral reduction of tariffs and other barriers in advanced industrial countries so as to boost developing countries' exports. The CFDT rejected this principle because it thought that it would sustain the existing international division of labor (and thus imprison developing countries in low value-added production) and, more importantly, directly threaten entire sectors of

promote this option was the case of the Lip factory, a watch factory that laid-offs workers reopened and managed for a couple of months in 1973. Although it did not last, this experience led the CFDT to develop economic counter-propositions when bargaining with employers (Branciard and Venturini 1986: 19, Groux and Mouriaux 1989: 171-176). On the origins and uses of the idea of self-management in French politics, see Georgi (2003).

¹²⁴ CFDT, "Nouveau type de développement et nouvel ordre économique international," p. 12.

¹²⁵ Nonetheless, the textile-apparel workers' federation doubted the actual effect of codes of conduct on MNCs.

the French economy and hence employment in these sectors.¹²⁶ Moreover, in the late 1970s the CFDT launched a campaign called “Live and Work in the Country” (*Vivre et travailler au pays*) that aimed at defending and creating good jobs in all regions rather than just leading urban centers as well as promoting local grassroots power against a centralized technocratic system. Such aspirations required, according to the CFDT, the promotion of French national industries so as to avoid being dependent on foreign demand and capital. This condition directly contradicted the third world’s demand that advanced industrial countries open up their domestic market to the exports of developing countries.¹²⁷ CFDT Secretary General Edmond Maire made a similar point when he stated, in a speech delivered at the federal congress of the textile-apparel federation, that:

In the future international trade should aim at developing countries becoming self-reliant, that is, not a development limited to certain productions but a balanced one as well as a balanced industrialization. . . . It is necessary to maintain in these countries and in France a sufficient and balanced industrialization. . . . At the CFDT we want the national production in each industrial sector to continue to cover a good share of the national consumption. It is a necessity for the defense of the interests of workers and the interest of our country.¹²⁸

The CFDT’s position toward the NIEO was ambiguous and implicitly denied that international trade was partly driven by the logic of comparative advantage. Countries needed not specialize in a specific sector and a segment of the value chain. They needed instead to do a bit of everything.

The CFDT’s position toward global economic integration in the 1970s appears thus as a confused effort to avoid the opposition between protectionism and free trade. The

¹²⁶ CFDT, “Nouveau type de développement et nouvel ordre économique international,” p. 14.

¹²⁷ CFDT, “Nouveau type de développement et nouvel ordre économique international,” p. 9-10.

¹²⁸ Quoted in Hacuitex-CFDT, “Le livre blanc pour le maintien et le développement des industries textiles, habillement et cuirs en France,” p. 21-22.

CFDT claimed that the NIEO could not avoid the potential conflict between workers of the North and the South because it was still too dependent on the productivist model of advanced industrial countries that gave priority to financial return and the development of productive forces (i.e., technology). It was not alternative enough. According to the CFDT, a real alternative involved producing *for* workers and *differently*. In both cases, the required structural changes involved the socialization of the means of production, democratic planning, and worker self-management.¹²⁹

2.3. Alliances and Tactics: Critical Convergence and Social Front

In practice, in the 1970s the CFDT tried to link up with not so much foreign workers as French political parties. Its strategy remained essentially national. Because it believed that solving the problems brought about by globalization required substantial structural changes, the CFDT invested considerable resources in coalition-building with political forces, particularly the PSU, led by Michel Rocard, and the PS, led by François Mitterrand. In spite of its antistatist culture, the CFDT thus repeated a familiar behavior in French industrial relations, in that it compensated its organizational weakness and inability to pressure peak business organizations and engage in collective bargaining with an investment in politics to obtain a favorable state intervention.

Put briefly, there were three stages in the coalition-building efforts of the CFDT in the 1970s. First, in contrast to the CGT, the CFDT refused to support the Common Program signed in 1972 by the PS, the PCF, and the Left Radicals. It thought that this

¹²⁹ CFDT, “Nouveau type de développement et nouvel ordre économique international,” p. 10-11.

Program was still too productivist, neglected qualitative issues, and too statist. In the second stage, in 1973, the CFDT attempted to build an alternative to the Common Program that was called the Union of Popular Forces and gathered the PSU and the radical self-management left. The initiative failed completely and fostered important internal divisions around the issue of trade union autonomy. Finally, in the third stage, the CFDT participated in the 1974 “Assises du socialisme,” an initiative launched by the PS to improve its leadership over the left. The CFDT thought that it would be able to influence the orientation of the PS through informal alliances with former PSU leaders, such as Rocard, who had recently joined the PS. But it failed again. Not only did Mitterrand manage to isolate former PSU leaders and their CFDT allies but the CFDT’s plan accentuated internal conflicts.¹³⁰

The coalition-building efforts of the CFDT can be understood as a short-term instrumental cooperation aimed at pulling resources so as to compete with the CGT in the industrial relations arena. The main resource that the CFDT was trying to increase was legitimacy so as to foster its ability to attract and mobilize workers. The CFDT had initially competed with the CGT through a divergence strategy that stressed its distinctive features and identity and ruled out cooperation. This strategy proved to some extent effective but was gradually revised in the mid 1960s and, above all, in the early 1970s, when the PCF and the PS signed the Common Program with the support of the CGT.

The new strategy of the CFDT was formed through successive steps as the CFDT tried to foster the consolidation of a non-communist political axis that would undermine

¹³⁰ The only consolation of the CFDT was perhaps that during the 1970s the idea of worker self-management spread to most forces of the French left. By the late 1970s, even the PCF was promoting it. Nonetheless, the meaning attached to it varied from one actor to another (see Georgi 2003).

the dominance of the PCF and the CGT over the French left. This new strategy involved competing no longer through divergence but through critical convergence: the CFDT downplayed its fundamental disagreements with the CGT and engaged in ad hoc alliance-building with it as well as political parties; but this convergence remained critical insofar as the CFDT refused to support the Common Program and systematically asserted its political autonomy and antistatist principles inspired by social Catholicism and revolutionary syndicalism. Overall, however, the CFDT was forced to move toward the left of the political spectrum to compete with the CGT.

3 | ORGANIZATIONAL FAILURE: EXPERIENCING THE STRUCTURAL CHALLENGE

Starting in the late 1970s, the CFDT faced a structural challenge that became manifest through organizational failure, that is, when an organization no longer manages to mobilize critical resources and ensure cooperation among its leading members (cf. Wilson 1995: 30-31). This situation implied an internal legitimacy crisis and a societal legitimacy crisis.

3.1. The Internal Legitimacy Crisis

The internal legitimacy crisis began in the early 1970s, when the opposition to the dominant coalition led by CFDT Secretary General Edmond Maire came increasingly under fire. In the 1970 confederal congress, although there was a huge consensus on self-management socialism, democratic planning, and social ownership of the means of

production, there were three competing resolutions and divisions became obvious, particularly on the issue of party-union relations (Groux and Mouriaux 1989: 91, Tixier 1992: 285). Each faction invoked the ideal of self-management so as to rally opponents.

In the 1973 congress, the confederal majority began to systematically denounce leftist—particularly Trotskyite—infiltration strategies (*entrisme*) as efforts to hijack the organization for the benefit of specific political parties. The confederal majority was worried that the leftist opposition might channel all forms of discontent within the organization to undermine its authority. It thus declared that tendencies were allowed in the CFDT but that organized minorities—i.e., factions—were forbidden for the sake of the organization (Groux and Mouriaux 1989: 194). However, this effort was not really successful, as the far left increased its audience and presence after 1974 (Lewis 1988: 360-361).

Before the 1976 congress, things were even more polarized inside the CFDT. After the confederal effort at influencing the PS through the Assises du Socialisme had failed, a dissenting faction called the Trade Union Left decided to support the PS faction CERES at the expense of the socialist allies (Rocardians) of the confederal majority. While the Rocardians shared with the confederal majority an antistatist perspective, the CERES embodied the more traditional, Jacobin statism of the French left. In the 1976 congress, the Trade Union Left and several federations of the CFDT (including Hacuitex, PTT, Health, Banking) presented a motion to pool the discontent and destabilize the confederal majority (Hamon and Rotman 1984: 285). Secretary General Edmond Maire replied with a critique of leftist messianism and infantilism and denounced the subordination of the Trade Union Left to electoral politics (Hamon and Rotman 1984: 287, Tixier 1992: 295).

In the three years that followed, the struggle between the confederal majority and the internal opposition (whether embodied by the Trade Union Left or small Trotskyite networks) intensified. Throughout this period, Maire kept denouncing the utopian cult of the rank and file (*basisme*) and warning members of the confederal majority that the freedom of local unions, membership growth, and the very autonomy of the CFDT were at stake (Hamon and Rotman 1984: 291). But this did not halt the progression of leftists, whose audience and presence continued to increase (Lewis 1988: 305, 361).

It is at this moment that the confederal majority reached the conclusion that substantial decisions had to be made in order to solve the internal legitimacy crisis that the CFDT had been experiencing for the last few years. Organizational reforms were necessary to ensure the position of the dominant coalition as well as the maintenance of the CFDT, for the membership of the organization was beginning to drop.

3.2. The Societal Legitimacy Crisis

The societal legitimacy crisis that the CFDT faced became manifest in the late 1970s, when the internal legitimacy crisis was already under way. Its main indicator is the drop of the CFDT's membership. After reaching a peak in 1976, the membership of the CFDT began to decline regularly (see Table 5.1).

We can identify three stages in the evolution of the CFDT (see Figure 5.1). A first period—going from 1964, when the CFDT was founded, to the late-1970s—during which class politics was effective and allowed it to successfully attract members. A second period, from 1982 to 1988, during which the decline accelerated swiftly and forced the

leadership of the CFDT to intervene. Finally, the third period began in 1989, when the decline was stopped and the CFDT attempted to reconstruct and consolidate its constituency through a new strategy of resource mobilization no longer based on class politics.

Table 5.1: Total Membership of the CFDT, 1965-1995 ¹³¹

Year	Total Membership	Year	Total Membership	Year	Total Membership
1965	454,000	1976	750,000	1987	427,000
1966	470,000	1977	750,000	1988	411,000
1967	484,000	1978	728,000	1989	414,000
1968	544,000	1979	706,000	1990	428,000
1969	588,000	1980	672,000	1991	438,000
1970	605,000	1981	667,000	1992	450,000
1971	628,000	1982	674,000	1993	473,000
1972	644,000	1983	613,000	1994	490,000
1973	695,000	1984	537,000	1995	500,000
1974	702,000	1985	482,000		
1975	737,000	1986	446,000		

Sources: Visser (2000: 276-277).

¹³¹ It is notoriously difficult to obtain reliable data on union membership. The data from Visser cited here does not match the data mentioned by Hamon and Rotman (1984) and Groux and Mouriaux (1989). I decided to rely on Visser because he provides data on all leading trade union organizations in France from 1965 to 1995. His data will thus also constitute the basis of Chapter 6 on the CGT. Having said that, it is worth pointing out that regardless of differences, all studies indicate similar a pattern in the evolution of the CFDT's membership.

Figure 5.1: Total Membership of the CFDT, 1965-1995

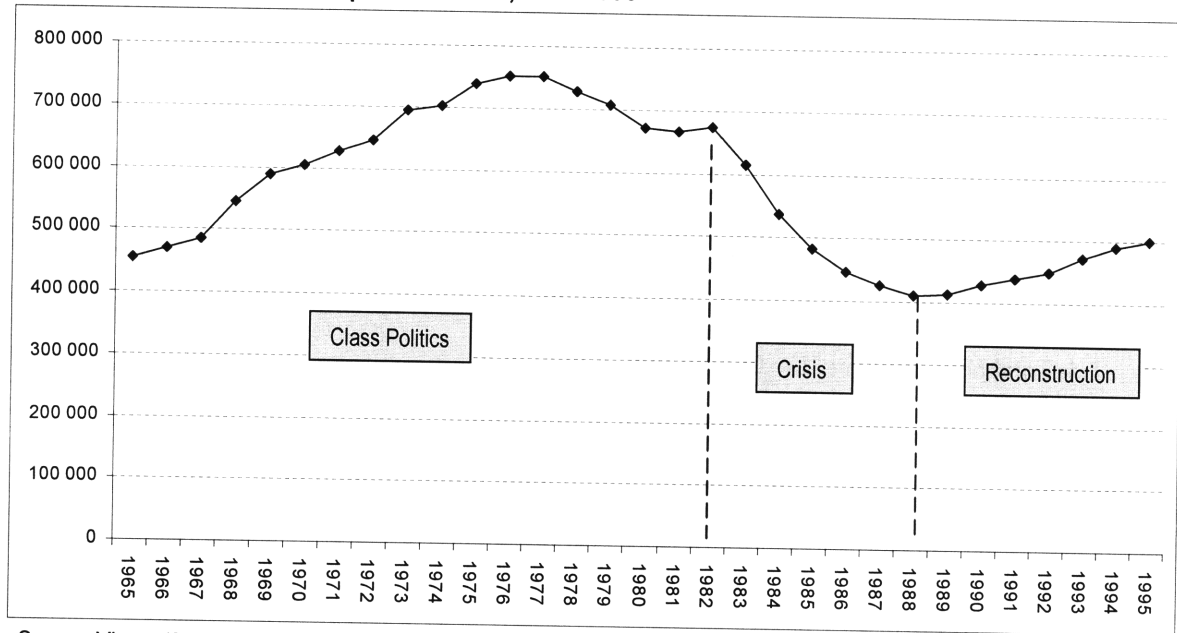

Source: Visser (2000: 276-277).

The membership drop reflected not only changes in the structure of the labor market but also the non-renewal of membership. In the late 1970s and 1980s a growing number of CFDT members simply stopped paying their dues because they thought the CFDT was too engaged in political debates and action rather than defending their interests (Labbé et al 1990). They thought the CFDT was too politicized.¹³² It follows that the societal legitimacy crisis that the CFDT experienced was fed by its inability to deliver adequate purposive incentives (tangible suprapersonal goals, like reforms, that justify the maintenance of the organization) to its members. In claiming that reforms required a leftwing government, the political discourse of the CFDT not only produced purposive

¹³² "Politicization" refers to explicit electoral support for political parties, promotion of policy packages and programs advocated by specific political forces, and defense of political principles like democratic liberties and human rights (Labbé et al 1990: 83).

incentives biased in favor of parties at the expense of unions, it also drove potential members away.¹³³

At first, the confederal leadership did not pay much attention to this incipient societal legitimacy crisis because membership had been progressing since the foundation of the CFDT in 1964. As Michel Lenoir, who participated in a massive field research launched by the confederal leadership in 1984 in order to stop the membership hemorrhage, explains:

From 1965 to 1976, there were twelve years of unionization, twelve years of progression. So the CFDT did not ask many questions about development and membership. . . . And then in 1977-82 was a period during which we spoke of erosion. It was a modest [*pudique*] word, in fact, to hide the fact that de-unionization had begun in 1977. And each year, we were losing 2, 3, 4 percent of our members.¹³⁴

The confederal leadership was not too worried initially because the membership decrease was compensated by the stable performance of the CFDT in professional elections, one of the main indicators of union strength in France. Throughout the 1970s and 1980s, the CFDT's share of the vote in work councils in the private sector fluctuated between 19 and 22 percent (Visser 2000: 247). Furthermore, while the overall unionized population was decreasing in most traditional industrial sectors, the CFDT's share of unionized workers remained stable and even increased in some sectors (see Figure 5.2). For example, its share of the unionized population in the textile and apparel sector went down from 28.2 percent in 1970 to 22.6 percent in 1980 but then up to 27.8 percent in 1985 (Visser 2000: 275). The CFDT textile-apparel workers' federation was losing many members as plants were

¹³³ On the traditional minor role of purposive incentives among French unions, see Lange et al (1982: 271).

¹³⁴ Interview with author, April 22, 2003.

closing but it managed nonetheless to maintain its share of the total unionized population in the sector whereas the CGT plummeted.

Figure 5.2: Share of Unionized Workers by Sector

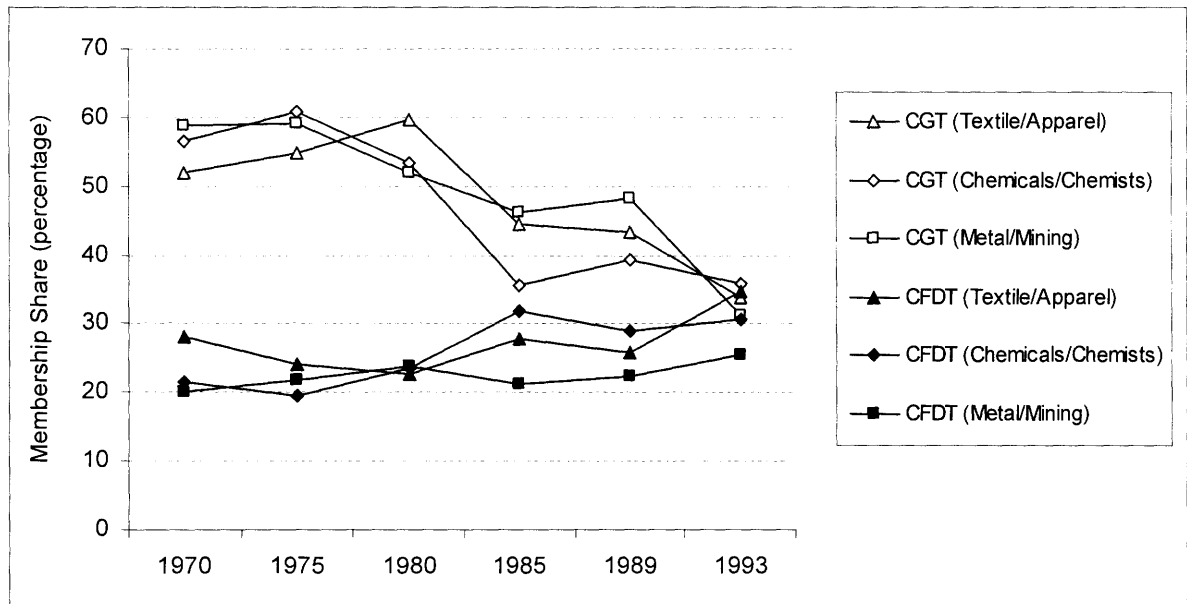

Source: Visser (2000: 275).

In the late 1970s and early 1980s, the confederal leadership was more worried about the internal than the societal legitimacy crisis. It knew that its membership was decreasing but did not think that numbers had to become a priority. As Michel Lenoir recalls, “In 1979-80, the confederation and the apparatus tried to renew the process of unionization. Decisions were taken unanimously but remained at the stage of internal notes without consequences. The organization decided that something had to be done. Everybody agreed but nobody did anything.”¹³⁵

¹³⁵ Interview with author, April 2003.

In the early 1980s, all the indicators were pointing in the same direction. The financial situation of the CFDT was in very bad shape because fewer and fewer contributions were coming in,¹³⁶ a growing number of training sessions for union delegates were being canceled because not enough people were registering, and entire local union sections were being whipped off overnight.¹³⁷ And yet, the CFDT did not focus on the issue. At the time, the confederal leadership was mainly preoccupied with the 1981 victory of the left, the reform of industrial relations, and the deepening of the economic crisis. It is only in 1983 and 1984 that it realized the extent of the societal legitimacy crisis it was facing. It took a shock to shake the inertia. According to Lenoir: “In 1983, there was what we called the huge drop: 83, 84, 85, until 1988. This drop was really enormous insofar as we were losing between 10 and 12 percent of our members several years in a row.”¹³⁸ This is when the confederal leadership reached the conclusion that it was facing a crisis.

4 | THE POLITICS OF ORGANIZATIONAL MAINTENANCE

In the era of class politics, the CFDT was able to increase its resources and consolidate its position vis-à-vis the CGT. There was thus no incentive to innovate or transgress the bounds of what was deemed appropriate. The deepening of organizational failure in the late 1970s and, above all, early 1980s changed this dynamic and opened up a space for leaders aspiring to advance a new agenda (cf. Polsky 2000: 466). It created a critical

¹³⁶ Member contributions are a good indicator for the confederal leadership because they are centralized rather than managed at the level of workers' federations.

¹³⁷ Michel Lenoir, interview with author, April 2003.

¹³⁸ Interview with author, April 22, 2003. Figure 5.1 illustrates the magnitude of the drop.

juncture, that is, a moment during which radical reorientations become possible (Pierson 2004: 135).

The CFDT's efforts to maintain itself during the critical juncture opened by organizational failure led it to depart from the path it had taken during the era of class politics. The transformation of the path of the CFDT followed a logic of conversion, that is, the redefinition of goals, purposes, and discourse of an organization and a consequential redeployment of its resources (Streeck and Thelen 2005: 26, Thelen 2003: 226). Such redirection was the product of the organizational failure I described above, but also of intraorganizational political struggles shaped by the organizational repertoire and linkages of the CFDT.

In order to explain how the CFDT's politics of maintenance generated a given path rather than another, this section first discusses three causal mechanisms that account for the specific trajectory of the CFDT—bricolage, identity shift, and closure—and then explains how these mechanisms produced unintended effects that contributed to the rise of antiglobalization movement.

4.1. Bricolage

When using their repertoire to engage in bricolage, actors first weave a narrative of the problem they face. Different narrative constructions of the problem will favor different solutions over others. The CFDT's politics of organizational maintenance involved speaking two competing narratives that attributed blame to different actors and phenomena and, therefore, had different implications. Each narrative was told and supported by

different factions and alliances. The first one was put forward by the confederal leadership and claimed that the solution to organizational failure lay in the depoliticization of the CFDT. The second reacted to the confederal narrative and argued that the CFDT should persevere in its anticapitalist orientation. This narrative was sustained by the Trade Union Left and several federations, including the textile-apparel workers' federation and the postal and communication workers federation.

The Confederal Narrative

The confederal leadership of the CFDT started thinking about organizational failure in the late 1970s, before the membership of the CFDT dropped significantly. The confederal narrative first became public in a report presented by Jacques Moreau, CFDT National Secretary for Political Affairs, in January 1978. The Moreau Report, as it quickly came to be known, asserted that the CFDT had invested too many resources in electoral politics and hopes in the leverage of an elected leftwing government and that its resource mobilization strategy no longer fitted the national and international context: “The left cannot deny reality. The situation is no longer that of 1972 [year of the Common Program].” “We must ask ourselves if this practice [of privileging politics and governmental action] is relevant with the analysis of the emergence, role, functions, consequences, of multinational corporations and of industrial restructuring to which capitalism has been proceeding these last few years.”¹³⁹ According to Moreau, the CFDT’s investment in electoral politics led it to focus on opposing the rightwing electoral

¹³⁹ Jacques Moreau, “Rapport de situation générale,” Conseil national, CFDT, sessions of January 26-28, 1978, p. 3 and 9.

majority at the expense of obtaining concrete gains through negotiation. Moreau claimed that such political strategies were partly responsible for the weakness of trade unions and collective bargaining in France.

Henceforth, salvation laid in social compromise: “Obtaining concrete results, giving hope, requires necessary compromises with those that lead the economy and social life.”¹⁴⁰ Such a conception implicitly reconsidered the role of firms in a more positive light; they were no longer exploiters of the working class but potential agents of progress, even though employers and workers had different interests. Furthermore, Moreau insisted that the CFDT should no longer participate in top-down national protest days with the CGT and focus instead on collective bargaining at the industry level. In order to improve the CFDT’s leverage in negotiation, Moreau called for turning unionization into a priority and abandoning the traditional conception of membership as ideological commitment so as to expand the social base of the CFDT.

Similarly, in the 1979 congress of the CFDT Secretary General Edmond Maire noted that the membership of the CFDT was stagnant and resumed Moreau’s call for recruitment and organizing. But for Maire the issue was not simply building a more legitimate and stronger organization to engage in collective bargaining but also following the social evolution of society: “We remain a trade union organization dominated by a single masculine-industrial cultural model whereas the tertiary sector gathers 57 percent of workers, including 40 percent of women.”¹⁴¹ “Recentrage” and adjustment to the new structure of the labor market were presented as two faces of the same coin. If the CFDT did

¹⁴⁰ Moreau, “Rapport de situation générale,” p. 10.

¹⁴¹ Maire, “Présentation du rapport général,” 38th Congress, CFDT, May 8, 1979, p. 3.

not endorse them and stuck instead to its previous model, the argument went, it would suffer substantial damage.

The solution advocated by the confederal narrative involved a recombination of the CFDT's linkages by reducing the involvement of the CFDT with political parties and the CGT. These linkages had to be made weaker than they already were so as to improve the appeal and autonomy of the CFDT. But simultaneously, the confederal leadership drew on an older linkage to make its new strategy more feasible. In December 1977 it secretly contacted the National Council of French Employers (CNPFF) to initiate a dialogue. Although both organizations were very cautious, they relied on a common social Catholic ground¹⁴² and set up a commission composed of two members of the CFDT and two members of the CNPFF that met regularly throughout 1978; the CFDT also contacted Raymond Soubie, social affairs advisor of Prime Minister Raymond Barre (Hamon and Rotman 1984: 305). The idea was that the CFDT could not afford to depend on who was in office.

The Oppositional Narrative

The confederal narrative faced a strong opposition. The Moreau report was first rejected by the National Council of the CFDT and approved only several months later, in May 1978, after the defeat of the left in the March legislative elections had granted more legitimacy to the claim that the CFDT should withdraw from electoral politics. The next battle took place during the 1979 confederal congress, when Edmond Maire endorsed the

¹⁴² CNPFF president François Ceyrac (in Nora 1984: 137) explained that many French employers had been influenced by the social doctrine of the Catholic Church and, therefore, could not be indifferent to a trade union shaped by it.

Moreau report and turned it into the new official strategy of the CFDT. Several workers' federations, particularly textile-apparel and postal and communication workers, denounced Maire's position and the "recentrage" as a conservative abdication to capitalism. The resolution of the confederal majority got only 56.7 percent of the vote, the lowest score ever obtained by a resolution proposed by the incumbents (Hamon and Rotman 1984: 327-328).

The oppositional narrative initially downplayed organizational failure. In the late 1970s, membership decline was still mild and in 1982 Edmond Maire even announced a 1 percent increase after three years of decline.¹⁴³ There was room for questioning the confederal diagnosis. Furthermore, the fact that several leading members of the CFDT participated in the socialist government in 1981-83 undermined the confederal claim that politicization had to be avoided. From the standpoint of dissenting factions, it simply showed that the real issue was the political orientation of the CFDT rather than the fact that it was invested in politics as such. The oppositional narrative thus emerged as a critique of the political shift that the confederal leadership wanted to impose on militants and members.

Initially, the oppositional narrative argued that membership losses were due to major socio-economic changes that led to the restructuring of entire industries like the steel and textile-apparel industries. The closing of large plants and increasing job losses translated into fewer union members. However, dissenting factions quickly changed the focus of their attack to target directly the confederal leadership rather than just denounce capitalism. They claimed that membership decline actually stemmed not from an

¹⁴³ Edmond Maire, "Présentation du rapport général," 39th Congress, CFDT, May 25-29, 1982, p. 26.

overpoliticization of the CFDT but from the very strategy that the confederal leadership had begun to implement. “Recentrage” was the real culprit because it abandoned socialism and favored peak-level negotiations with employers at the expense of rank-and-file mass mobilization.¹⁴⁴ In the 1982 confederal congress of the CFDT, Daniel Torquéo, then a rising leader and future Secretary General of the textile-apparel workers’ federation Hacuitex, stated: “When we left Brest [where the last confederal congress took place], the new strategy was supposed to remobilize the working class. This mobilization did not happen and we must ask ourselves why.”¹⁴⁵ This interpretation became recurrent in internal debates. For example, in 1984 the textile-apparel federation intervened in a meeting of the CFDT’s National Council:

The current de-unionization [*désyndicalisation*] comes in great part from the change of orientation of the CFDT. . . . In our reflection on the causes of de-unionization, it has become clear that the lack of action was one of the causes of the loss of confidence of workers. . . . we see that many militants are demobilized by the current change of orientation. They no longer identify with the CFDT. They have doubts, ask questions, and that undermines unionization.¹⁴⁶

The oppositional narrative basically blamed the “recentrage” for a deepening of organizational failure. It denounced its ideological implications, accusing it of redefining the firm as a place of economic effectiveness where contradictory interests meet, of presenting the market as the guarantor of individual liberties, of depicting the strike as

¹⁴⁴ Interview with Léon Dion, Secretary General of the textile-apparel workers’ federation of the CFDT in the late 1970s and early 1980s, April 2003. The textile-apparel workers’ federation was one of the leading dissenters.

¹⁴⁵ Daniel Torquéo, “Congrès confederal de Metz: Intervention fédérale,” *Hacuitex* No. 356, June/July 1982, p. 14.

¹⁴⁶ Hacuitex-CFDT, “Extraits de notre intervention sur l’adaptation du syndicalisme au Conseil national du 25 au 27 avril 84,” *Hacuitex* No. 375, May 1984, p. 14.

mythology, etc.¹⁴⁷ This perspective allowed it to coalesce different political sensitivities, from the more statist the Trade Union Left to the more “basist” far left.

The solution that stemmed from such interpretation of the problem was to return to a more radical political orientation in line with self-management socialism and mobilize rank-and-file workers in the workplace. The oppositional narrative presented leaders as disconnected from the base; only such gap would explain their political shift. Returning “sur le terrain” would increase the credibility of leaders and realign them with the alleged more radical political sensitivity of the rank-and-file. Mobilization would then follow. In contrast to the confederal narrative that stressed apolitical membership, the oppositional narrative celebrated ideologically driven militants. Leverage in negotiations lay not in numbers (i.e., more members) but in a mass mobilization that would tip the power balance in favor of unions.¹⁴⁸ Therefore, not surprisingly, the oppositional narrative defended the alliance with the CGT as a core element of the resource mobilization strategy of the CFDT. Established linkages had to be consolidated, that is made stronger, instead of weaker as the confederal leadership had been doing.

Bricolage Under Constraints

In spite of all their differences, the confederal and oppositional narratives both drew upon the organizational repertoire of the CFDT. The confederal narrative was more deeply anchored in the repertoire of the CFDT, as it stood at the intersection of its three axes, antistatism, anticommunism, and a Christian ethics critical of the market but downplaying

¹⁴⁷ Hacuitex-CFDT, “Présentation du 42ème congrès fédéral,” *Hacuitex* No. 397, August/September 1986, p. 4.

¹⁴⁸ Interview with Léon Dion, Secretary General of the textile-apparel workers’ federation of the CFDT in the late 1970s and early 1980s, April 2003.

class antagonisms. The oppositional narrative drew upon the more recent element of the repertoire of the CFDT, self-management socialism. Edmond Maire initially tried to use this resource by presenting “recentrage” as the ultimate embodiment of self-management socialism,¹⁴⁹ but eventually abandoned the reference to socialism and then to self-management so as to replace it with social dialogue.

Organizational linkages also played a constraining role. In trying to formulate a solution to organizational failure, the confederal leadership recombined old and new linkages. On the one hand, it unearthed an old and weak linkage with Christian employers. On the other hand, it put on hold its linkage with the CGT and cultivated the linkage it had been building with the Socialist Party throughout the 1970s. It did not have other linkages—such as relations with other reformist trade unions or other political parties—on which to build. The only alternative was to build on weak linkages with social movement organizations but the latter were not strong enough to represent a substantial pool of resources that could have helped remedy organizational failure. Moreover, social movements were often critical of the “recentrage” strategy and gradually distanced themselves from the CFDT (Georgi 2004). Dissenting factions remained closer to social movements and even today, they cooperate with the antiglobalization movement. However, their priority has been the defense of the linkage with the CGT as a counterweight to the confederal leadership.

In 1984, the confederal leadership decided to by-pass all federations and regional unions and put together a team of four men to travel around France and interview rank-and-file members so as to understand membership decline. This group was called the

¹⁴⁹ Edmond Maire, “Présentation du rapport général,” 38th Congress, CFDT, May 8, 1979, p. 6.

Action Group for Unionization (Groupe d'action pour la syndicalisation, GAPS). In the 1985 confederal congress of the CFDT, unionization became a top priority and the GAPS, which was until then semi-clandestine, came out in the open.¹⁵⁰

The GAPS produced a relatively consensual diagnosis. It stressed both external (economic crisis, lack of union autonomy from political parties, rise of individualism, crisis of historical role of unions) and internal (gap between union delegates and the rank and file, lack of participation of rank-and-file members in local unions, lack of clear agenda, vague or even negative conception of ordinary members) factors.¹⁵¹ This picture took into account the claims of both the confederal and oppositional narratives and appealed to the interests and identities of the competing factions underlying them.¹⁵² In doing so, it made it possible to build an ad hoc convergence around a limited solution, namely, increasing the number by a recruitment campaign. Each federation had to solicit the help of the GAPS to train “developers” that would go from one local union to another to revitalize them and make them attractive to potential members anew. Apparently confirming the effectiveness of the GAPS, membership drop stopped in 1988, after more than ten years of steady decline. The confederal leadership was able to claim the credit for this major change in the 1988 confederal congress and, in doing so, reasserted its control of the organization.¹⁵³

¹⁵⁰ CFDT, “Histoire d'une courbe,” March 20, 1998, p. 10.

¹⁵¹ CFDT, “Histoire d'une courbe,” March 20, 1998, p. 11-14.

¹⁵² According to Michel Lenoir, one of the four original members of the GAPS, the GAPS's diagnosis was accepted by *all* the federations. Interview with author, April 2003.

¹⁵³ As I will explain in the next section, it was not the only device to regain control of the organization. Closure was also at work.

Through the GAPS, the CFDT encouraged, in Albert Hirschman's terms (1970), rank-and-file voice as a way to foster loyalty and prevent exit. Such a scenario would have been unimaginable in the CGT. At the same time, the diagnosis that the GAPS constructed from the interview data it collected did not step outside of bounds of the confederal and oppositional narratives. The voice of the rank and file was molded to fit the conceptual categories provided by the repertoire of the CFDT.

4.2. Identity Shift

As the confederal leadership developed its narrative it gradually redefined the collective identity of the CFDT at the expense of internal opponents. This identity shift implied the formation of a new boundary between so-called "responsible realists" (the in-group structured around the confederal leadership) and so-called "archaic ideologists" (the out-group identified with dissenting factions).¹⁵⁴

Officially the "recentrage" was not a move toward the center of the political spectrum—although it did have such implication insofar as it recognized the positive contribution of capital and favored negotiation over protests—but an attempt to adjust the CFDT to the new social, economic, and political context, by expanding its social base and reallocating its resources toward a new goal: emancipation through negotiation and social dialogue. This recasting of the goal of the CFDT involved a redefinition of the boundaries of legitimate trade union action that excluded some former allies as well as dissenting

¹⁵⁴ The labels that I use derive from official speeches and field interviews with CFDT national and local leaders carried out in 2002 and 2003.

factions of the CFDT. Common actions with the CGT as well as mass mobilization at the rank-and-file level were discredited. In contrast, seeking a compromise with employers through negotiations was valued. Members that challenged the claim that negotiation and social dialogue could ensure organizational maintenance, let alone achieve emancipation, were denigrated and labeled as “archaic” by the confederal leadership.¹⁵⁵ Already in the 1979 confederal congress, Secretary General Edmond Maire, responding to critiques after he had presented the “recentreage” strategy, stated that the “leftist opposition” was the real conservative and that it was time the workers’ movement surpassed its infantile stage in which verbal radicalism and anticapitalism replaced concrete gains.¹⁵⁶ Such logic fed a dynamic of polarization, forcing actors to choose sides and, thereby, reinforcing the boundary between in-group and out-group.

Two symbolic decisions deepened the identity shift of the CFDT. First, in the 1985 confederal congress the confederal leadership announced that it would no longer recommend to vote for a specific candidate during elections for office on grounds that it would jeopardize the autonomy of the CFDT and misrepresent the plurality of its members. Second, in the 1988 confederal congress it abandoned all references to democratic socialism to avoid being associated with the Socialist Party or the Soviet Bloc. Self-management was boiled down to a “principle guiding the choices of the CFDT” and the market was henceforth accepted. In 1992, an official CFDT booklet presenting the history of the organization to new recruits pointed out:

¹⁵⁵ Interview with Léon Dion, Secretary General of the dissenting textile-apparel federation of the CFDT in the late 1970s and early 1980s, April 2003.

¹⁵⁶ Edmond Maire, “Réponse aux intervenants sur le rapport d’activité,” 38th Congress, CFDT, May 8, 1979, p. 8.

Recent texts no longer reason in terms of “class struggle,” but in terms of opposition between two logics within the rehabilitated firm. The 1988 congress characterizes these two logics in the following way: “That of the employer [*chef d’entreprise*], in which profit and financial, technical, and commercial aspects prevail over human and social aspects; that of the trade union and workers, which starts from the wage situation, employment, skills, labor and living conditions. These two logics are by nature in conflict, but can find a positive outcome through negotiation.”¹⁵⁷

In a more subtle way, the GAPS contributed to this shift by diffusing an apolitical conception of membership in line with the confederal narrative. It stressed that a militant conception of membership—according to which only actually militant mattered whereas ordinary/non-militant members were useless to the union—undermined mobilization and advocated instead a vague “membership unionism” (*syndicalisme d’adhérents*) aiming primarily at collective bargaining.¹⁵⁸

Therefore, the confederal leadership redefined the collective identity of the CFDT by distancing it from its previous class anchoring. As Richard Hyman (2001) has noted, it is possible to distinguish three ideal types of European trade unionism associated with distinctive ideological orientations: *Class unionism* (anticapitalist opposition and defense of class interests), *social unionism* (aiming at social integration and taking into account interests beyond class), and *business unionism* (focused on collective bargaining and other market functions). They embody three different ways of articulating the relationship between class, market, and society. In practice, most trade unions “have tended to incline towards an often contradictory admixture of two of the three ideal types” (Hyman 2001: 4). In the 1960s and 1970s, the CFDT stood between class and society. But between 1979 and

¹⁵⁷ CFDT, *Notre histoire en marche: Histoire et identité CFDT*, “Repères pour la formation,” Institut confédéral d’études et de formation syndicales (ICEFS), CFDT, Paris, 1992, p. 29-30.

¹⁵⁸ CFDT, “Histoire d’une courbe,” March 20, 1998, p. 25, and interview with GAPS member Michel Lenoir, April 2003.

1988, the confederal leadership shifted the identity of the CFDT from the class-society axis to the society-market axis (see Figure 5.3). In redrawing the boundaries of the CFDT in such manner, the confederal leadership depicted the previous class orientation not only as archaic but also as *alien* to the organization. Dissenting factions were allegedly manipulated by external elements whose real primary concern was not the maintenance of the CFDT but some other political goal. The confederal leadership thus tried to deprive its internal opponents of legitimacy.

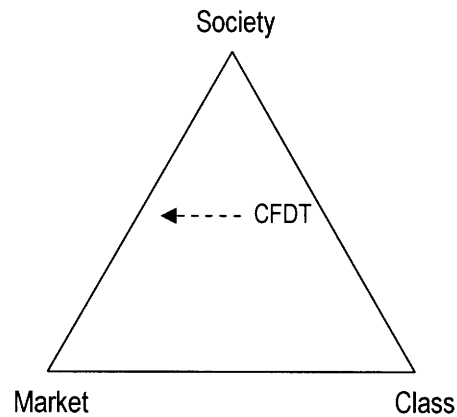

Figure 5.3: The Identity Shift of the CFDT

4.3. Closure

In order to impose its new orientation, the confederal leadership closed the organizational opportunity structure of the CFDT. This shift involved (1) an increase of executive intolerance and repression, (2) a decrease of potential challenger access to the decision-making process, and (3) a more cohesive dominant coalition reducing or ruling out the possibility of divisions that could be used by challengers. I discuss each aspect below.

Intolerance and repression increased in the late 1970s, as the confederal leadership was launching its “recentrage” strategy. In 1977, the Departmental Union of Gironde, particularly supportive of soldiers committees created by the Trotskyite Communist Revolutionary League (LCR), was dismantled.¹⁵⁹ That same year, the local unions of the 8th and 9th districts (*arrondissements*) of Paris suffered the same fate (Hamon and Rotman 1984: 289 note 2). Similarly, a year later, the staff of the Departmental Union of the Rhône was replaced (Groux and Mouriaux 1989: 91). In subsequent years, as the confederal leadership was redefining the collective identity of the CFDT toward the market-society axis, it used the prerogatives of its position to enforce the new symbolic boundary. This trend culminated in 1988, when several Paris unions of the postal and communication workers federation and of the health workers federation were excluded for engaging in a strike against the direct orders of the confederal leadership. Pierre Héritier, the leader of the extinct Trade Union Left, whom had joined the ten member team of the Executive Commission of the CFDT in 1982 and represented the only dissenting voice in the confederal leadership, was expelled as well during the 1988 congress. The CFDT was far from its years of radical self-management socialism. Such intolerance and repression increased the cost of collective action inside the CFDT and made it harder for dissenting factions to mobilize supporters.

Another strategy to neutralize dissenting factions was to limit the points of access to the decision-making process. This was done in two different ways. First, the confederal leadership increasingly by-passed the National Council of the CFDT, where dissenting factions were represented, as well as federations and tried to contain and centralize debates

¹⁵⁹ Soldiers committees were informal unions in the French armed forces.

and decisions within the Executive Commission. For example, the decision to support the 1983 socialist austerity policy was made by the executive without a large, inclusive internal debate.¹⁶⁰ Opponents complained that this logic entailed a shift toward authoritarianism, homogenization, and exclusion.¹⁶¹ The second way to limit access to the decision-making process was to try to change the demographic balance between supporters of the confederal leadership and supporters of dissenting factions. Thus, an unofficial motive of the GAPS was to foster recruitment in local unions controlled by the far left so as to gain a majority. As GAPS member Michel Lenoir explains:

The health workers federation became the first federation of the CFDT today because it developed extraordinarily. And also because a great number of its sections and local unions were controlled by the far left, in whose hands the federation was about to fall. A certain number of militants from Brittany and the Loire said that they could not stand by without doing something. The only means in order to win was to multiply the number of organizations inside the organization. There was a real effort . . . that brought us new members, a new generation of militants, and the marginalization of the far left.¹⁶²

Intolerance and repression, on the one hand, and decreasing challenger access to the decision-making process, on the other, fostered the third aspect, namely the cohesion of the dominant coalition. As dissenters were expelled from the Executive Commission, opponents marginalized, and new members joining the CFDT—which reinforced the demographic balance in favor of the confederal leadership as well as increased its legitimacy for stopping membership decline and ensuring organizational maintenance—the dominant coalition was more united than ever. It was in the name of cohesion that

¹⁶⁰ More recently, many members of the CFDT criticized the decision of the confederal leadership in 2003 to accept the reform of pensions proposed by Minister François Fillon without consulting the rank and file.

¹⁶¹ Hacuitex-CFDT, “Congrès confédéral de Strasbourg: Continuité dans le changement,” *Hacuitex* No. 420, December 1988, p. 15.

¹⁶² Interview with author, April 2003.

Secretary General Edmond Maire demanded that Pierre Héritier be expelled from the Executive Commission in 1988; it was again in the name of cohesion that the Executive Commission went from 11 to 8 members (Groux and Mouriaux 1989: 282-83). Weakened challengers did not have a single sympathizer at the new Executive Commission.

This process of closure had implications for interorganizational relations insofar as it pushed marginalized dissenting factions to seek resources and allies outside of the CFDT. As I will explain in the next section, renewed competition is a central unintended outcome of the closing of the organizational opportunity structure.

4.4. The Unintended Consequences of Conversion

The adjustment process that I described above followed a logic of conversion, that is, the redefinition of goals, purposes, and discourse of an organization and a consequential redeployment of its resources (Streeck and Thelen 2005: 26, Thelen 2003: 226). The CFDT went from being an organization aimed primarily at the defense of class interests through a radical contestation of the capitalist order to an organization claiming to defend the interests of its members and of society at large through collective bargaining and social partnership. This shift entailed a redeployment of resources toward recruitment and training (an agency specifically dedicated to training recruiters was founded) as well as the recombination of organizational linkages.

This process of conversion was the outcome not only of the bricolage and identity shift in which the confederal leadership engaged, but also of a deliberate effort to marginalize internal opponents through a closing of the organizational opportunity

structure. While bricolage and identity shift were the central mechanisms of *change* through which the confederal leadership generated a new path, closure was the central mechanism of *stabilization* that reinforced this path once it had been taken. Without closure, dissenting factions could have perhaps reversed the changes initiated by the confederal leadership and brought the CFDT closer to its former path, thereby preventing the completion of the CFDT's conversion.

However, the CFDT's conversion had the unintended effect of contributing to a future renewal of competition. It did so in two ways. First, closure brought about a schism, as some dissenting militants from the postal and communication workers federation that had been expelled in 1988 decided to found a new organization called SUD-PTT (Solidarity, United, Democratic).¹⁶³ As I explained in Chapter 4, SUD challenged the CFDT's and the CGT's hegemony in professional elections in postal and communications services and subsequently became a central actor in the antiglobalization movement.¹⁶⁴

The CFDT's conversion contributed to a future renewal of competition in another way as well. As Thelen (2003: 231) suggests, the losers of organizational change do not necessarily disappear or adapt. Even weakened, they can stick around. Their weakness inside the organization can actually become an incentive to look for new external resources. Because the closing of the organizational opportunity structure had deprived them of resources, dissenting factions inside the CFDT sought outside allies so as to counterweight the hegemony of the confederal leadership. During the 1980s, a strong

¹⁶³ PTT simply refers to postal and telecommunication services.

¹⁶⁴ However, in terms of membership SUD remained marginal compared to leading French trade unions. Its membership went from 1,843 in 1990 to 5,847 in 1995 and 10,946 in 1998 (Denis 2001: 216). In contrast, in 1998 the CFDT had more than 700,000 members.

potential ally was the CGT. In 1998, dissenting factions saw the incipient antiglobalization movement as a venue for improving their leverage and participated in the creation of ATTAC. They engaged in what Keck and Sikkink (1998: 12) call a “boomerang strategy,” through which they bypassed the executive of their organization and developed alliances with outside actors so as to bring pressure on their own organization from outside (see Figure 5.4).¹⁶⁵

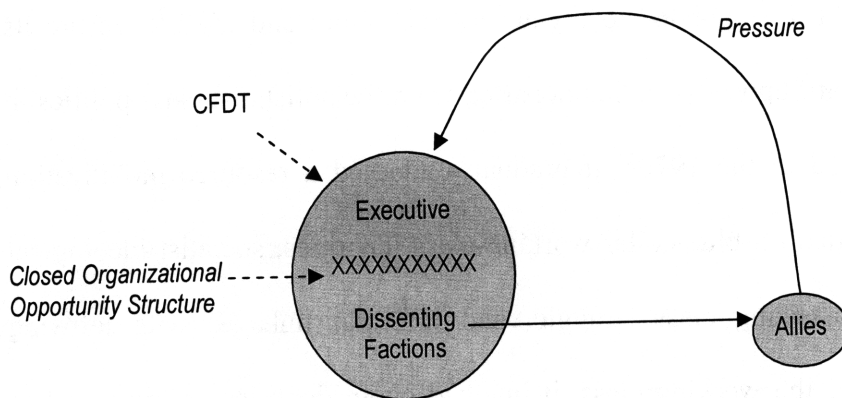

Figure 5.4: The Boomerang Strategy

Therefore, although closure significantly reduced competition inside the CFDT, it fostered competition between the CFDT and new organizations. Challengers did not disappear. Some moved out while others stuck around and tried to pressure the CFDT from the outside. In both cases, closure had the unintended effect of contributing to the rise of the antiglobalization movement. At the same time, however, this renewed competition did not push the CFDT to depart from the path upon which it had embarked with the “recentage” strategy. On the contrary. The fact that the challenge now came from *outside*

¹⁶⁵ Keck and Sikkink (1998) apply the concept of boomerang strategy to transnational and international relations. They argue that it is a strategy that actors, like NGOs, can adopt when the channels between the state and its domestic actors are blocked. I simply applied this logic to interorganizational relations.

instead of *inside* the organization consolidated the new collective identity of the CFDT and its boundaries. External threats tend indeed to produce in-group solidarity (Ansell 2001: 28).

5 | RESPONSES TO GLOBALIZATION AFTER CLASS POLITICS: THE ADAPTATION STRATEGY

The way in which the CFDT responded to organizational failure and tried to ensure its maintenance led it to embark upon a path that departed from the antistatist class politics in which it had been engaged in the 1970s. It gradually adopted a resource mobilization strategy that no longer relied on blue-collar working-class identities, socialist ideological appeals and beliefs emphasizing class struggle, and informal linkages with leftwing political parties. Instead of the working class, it invoked civic identities and invested in social partnership with employers. Insofar as membership decline stopped in 1988 and increased up to 2003, there no longer was a big incentive to innovate. The persistent marginalization of dissenting factions reinforced this choice. The CFDT was engaged anew in a politics of organizational stability, making minor adjustments at the margins without departing from its new path. As Michel Agostini, head of recruitment and training at the CFDT, explains:

There still are debates [in the CFDT]—we debate about our demands, employment, pensions, industrial policy, the boom of services, the public-private cleavage, etc.—but they are no longer about our strategic approach and fundamental position. The debate is no longer what it was between 1978 and 1987, or between 1995 and 1998. . . . Today, those that didn't feel comfortable at the CFDT have left to SUD or somewhere else.¹⁶⁶

¹⁶⁶ Interview with author, April 2003.

Put differently, the new path upon which the CFDT embarked in the late 1970s and early 1980s has apparently stabilized.

The evolution of the CFDT's position toward globalization stems from this political-organizational process of path departure that began in the late 1970s. Although the organizational failure that the CFDT experienced was not directly related to globalization, the politics of organizational maintenance generated a process of change that led the CFDT to substantially revise its orientation, alliances, and tactics. In doing so, it transformed the CFDT's position toward globalization. In contrast to the full fledged opposition to globalization that it articulated in the past, today the CFDT officially advocates adaptation and holds a more cosmopolitan perspective. Such position puts it in an awkward place in French politics, simultaneously rejecting neoliberalism and statism. As a result, its relation with the antiglobalization movement is ambiguous at best, conflictive at worst. In what follows, I present the CFDT's interpretation of contemporary changes taking place in the international economy, its demands, and its alliances and tactics.

5.1. Interpreting the International Economy

We can distinguish three steps in the evolution of the CFDT's interpretation of the international economy. First, the CFDT changed its perception of the firm and the market. Second, it reached the conclusion that the national social compromise of the postwar settlement was outdated and that it had to be reconstructed at the European level. Third, it applied the logic of the two previous points—acceptation of the market and obsolescence of

the national social contract—at the global level and acknowledged the potential benefits of globalization.

The “rehabilitation” of the firm was at the center of the 1979 “recentrage” strategy in that it was a prerequisite to negotiations. The CFDT abandoned references to class struggle and socialism and even presented the firm as a space of social integration that protects workers from the “disorder and uncertainty of the market;” the more trade and the internationalization of production make the market uncertain, the more the firm is called on to play such protective role.¹⁶⁷ Similarly, in the 1988 confederal congress, while it stressed the role of public intervention in the economy, it “recognized the usefulness of the market as an element of economic dynamism, modernization, and ultimate guarantor of individual choices.”¹⁶⁸ Moreover, it developed a nuanced understanding of capitalism, rejecting the abstract theorization of a universal and ahistorical model to highlight instead the existence of national models of capitalism. It identified two such models—an American model based on the market and a European model based on the social contract—and ruled out claims about the convergence toward a single model.¹⁶⁹

While it was embracing the firm and developing a nuanced understanding of capitalism, the CFDT asserted that the post-war growth model and its nationally bound social contract were outdated and that it was unrealistic and undesirable to try to return to

¹⁶⁷ Secteur action économique-emploi, “Reconstruire notre projet social pour redessiner un horizon économique,” CFDT, May 4, 1987, pp. 27-28.

¹⁶⁸ CFDT, “Adaptation du syndicalisme,” 41th confederal congress of the CFDT, *Syndicalisme*, July 7, 1988, p. 13.

¹⁶⁹ CFDT, “Le syndicalisme face au défi de la mondialisation,” 44th confederal congress of the CFDT, *Syndicalisme Hebdo* No. 2709, September 3, 1998, p. 10. The idea of varieties of capitalism is widespread among political economists today. For statements of this approach, see for example Berger and Dore (1996), Hall and Soskice (2001), and Kitschelt et al (1999).

them.¹⁷⁰ The organization of production in large, vertically integrated firms had been replaced with transnational production chains and leading firms had begun outsourcing low value-added production to concentrate on high value-added products and services, thereby contributing to a fragmentation of the working class and a rise of services.¹⁷¹ Together with the increase of international trade and capital mobility, this transnational reorganization of production modified the relationship between firms and the nation-state and undermined the autonomy of national economic policies. The resulting discrepancy between the political space and the economic space entailed that the future of regulation laid in finding ways to transpose the old model at the supranational level.¹⁷²

In contrast to most French trade unions today, the CFDT depicts globalization in a positive light. It stresses three aspects. First, globalization is an undeniable fact. It is neither good nor bad; it is simply there.¹⁷³ Hence the need to adapt. Second, if the appropriate policies are implemented, globalization can be a source of growth and employment for advanced industrial countries. France has indeed benefited from it. Labor cost is not the only factor determining where firms locate their operations; productivity, local skills, proximity of innovation and R&D clusters, infrastructures, communication and

¹⁷⁰ Here, the CFDT's analysis blends elements of the Regulation School of Michel Aglietta and Robert Boyer with others reminiscent of John Ruggie's concept of embedded liberalism. This assessment permeates official reports and documents of the CFDT from the early 1980s on. See, for example: CFDT, "La situation économique actuelle et la politique économique du gouvernement," *Nouvelles CFDT* No. 15/82, April 16, 1982; and CFDT, "Rapport général: Le parti pris de la solidarité," 43rd confederal congress of the CFDT, *Syndicalisme* No. 2526, November 24, 1994, p. 8-9.

¹⁷¹ CFDT, "Rapport général: Le parti pris de la solidarité," 43rd confederal congress of the CFDT, *Syndicalisme* No. 2526, November 24, 1994.

¹⁷² This line of argumentation is recurrent. See, for example: CFDT, "La situation économique actuelle et la politique économique du gouvernement," *Nouvelles CFDT* No. 15/82, April 16, 1982; and CFDT, "Rapport général: Le parti pris de la solidarité," 43rd confederal congress of the CFDT, *Syndicalisme* No. 2526, November 24, 1994.

¹⁷³ CFDT, "Le syndicalisme face au défi de la mondialisation," 44th confederal congress of the CFDT, *Syndicalisme Hebdo* No. 2709, September 3, 1998; Notat (1997: 123-24).

information networks, and market access, are all key factors. According to the CFDT, globalization is not a zero-sum game: the growth of developing countries entails higher demand for goods and services provided by advanced industrial countries, thereby generating jobs, revenues, and growth in these countries.¹⁷⁴ Similarly, the CFDT believes that offshoring is not a major source of unemployment in France, although it acknowledges that low-skilled workers in some sectors (such as textile and apparel) are particularly affected by it. It also points out that offshoring is a two-way process: foreign firms often relocate their operations in France, thereby creating jobs (Notat 1997: 127).

The CFDT rejects any discourse that depicts competition from low-wage countries as the source of unemployment and poverty.¹⁷⁵ It believes that the development of these countries is necessary and desirable even it entails certain sacrifices for advanced industrial countries. For example, Nicole Notat (1997: 127), Secretary General of the CFDT from 1992 to 2002, asks: “Are we going to wish that the population of Tunisia or Taiwan be deprived of firms and jobs on grounds that we want to keep it all for us, which would be as scandalous as unthinkable?” Similarly, Michel Agostini, head of recruitment and training at the CFDT, explains: “If the relocation of the firm where I work allows third world countries to develop and third world people to eat decently and with dignity, then I’m for it. . . . Personally, I’m rather happy if Westerners are not the only ones eating all they want.”¹⁷⁶ Jean-François Trogrlic, head of international affairs at the CFDT, states: “Textile is today the first vector of industrialization for developing countries. These countries first

¹⁷⁴ Jean-François Trogrlic, “Présentation de la résolution sur la mondialisation,” 44th confederal congress of the CFDT, December 11, 1998, p. 2.

¹⁷⁵ CFDT, “Rapport général: Le parti pris de la solidarité,” 43rd confederal congress of the CFDT, *Syndicalisme* No. 2526, November 24, 1994, p. 7.

¹⁷⁶ Interview with author, April 2003.

exploit their agricultural resources—except those that have natural resources—and then turn to textile. So do we do? We keep textile in advanced industrial countries and we do not share? But then how do you promote the development of the world?”¹⁷⁷

The official statement adopted at the 45th confederal congress in 2002 is even more explicit: “International competition and the opening of emerging countries contribute indeed to a greater mobility of activities, whether it’s new operations, shifts in localization or restructurations. This evolution is not only necessary but also desirable: we cannot call for the development of these countries and refuse that they be our partners and competitors.”¹⁷⁸ This defense of developing countries suggests that the CFDT now holds a cosmopolitan position that takes as its fundamental unit individual citizens rather than classes or nations. The time when the CFDT denounced global economic integration as imperialism is long gone. As I will show in section 5.2, today it favors demands that could be labeled as “liberal internationalist” insofar as they rely on state intervention and coordination as much as on international institutions (cf. Kapstein 2006).

5.2. Demands

Since the mid 1980s, the demands of the CFDT have been formulated in a much more moderate language than in the past. The anticapitalist rhetoric and the talk about an alternative model of development have completely disappeared and the agenda of the CFDT now builds upon basic tenets of market economies such as comparative advantage

¹⁷⁷ Interview with author, April 2003.

¹⁷⁸ CFDT, “Le monde que nous voulons,” in *Agir sur la mondialisation*, Paris, CFDT, 2002, p. 58.

and innovation. Its demands with regard to globalization are congruent with its new collective identity standing along the society-market axis and blending social unionism and business unionism (cf. Hyman 2001). They are structured around three axes: the role of the state, the role of Europe, and the role of international institutions.

As in the era of class politics, today the CFDT rules out protectionist policies as a solution to France's social and economic problems. However, whereas in the 1970s and early 1980s this position was ambiguous because the CFDT also demanded a defense of the French domestic market and claimed that France was too integrated into the world economy,¹⁷⁹ today the CFDT's stance is pretty clear: it explicitly supports trade liberalization. The turning point of this evolution was the adoption in March 1983 of an austerity policy by CFDT-sympathizer Minister of Finance Jacques Delors, after a difficult battle against Jean-Pierre Chevènement and the CERES wing of the PS, representative of the traditional Jacobin, statist left, that advocated protectionism and exit from the European Monetary System (EMS).¹⁸⁰

In the immediate aftermath of this shift, the CFDT stuck to its position that free trade *within* the European Community was necessary while it was questionable with the rest of the world.¹⁸¹ Nonetheless, it gradually came to support global trade liberalization. In 1988, it argued that Europe should foster exports from developing countries and that

¹⁷⁹ Edmond Maire, "Comment concilier l'exigence de compétitivité et la poursuite de progrès social?," International Conference at UNESCO, June 4, 1980, p. 4.

¹⁸⁰ For an account of this policy shift, see Hall (1986).

¹⁸¹ For example, an internal note released in June 1983 stated: "In the case of France, things are simple: the space of 'free trade,' of the construction of an economic, social, and, to some extent, political community, is Europe. . . . If the borders of France are Europe, it is time Europe recognizes its borders. Either to protect the activities it is initiating or reconverting in all or part of its members, or to negotiate the modalities of its relations with third countries." Secteur emploi, secrétariat économique, "Echanges économiques extérieurs: Quelle politique, pour quoi faire?," CFDT, June 15, 1983, p. 11 and 13.

international financial institutions should stimulate capital mobility toward these countries.¹⁸² Ten years later, Jean-François Trogrlic, head of international affairs at the CFDT, declared: “It is not the time of protectionism, neither in France nor in Europe.”¹⁸³ Protectionism was tolerated only as a temporary measure for the least developed countries.¹⁸⁴ In 2001, after the WTO meeting in Doha, a CFDT memo remarked: “Resuming a cycle of negotiation will permit to increase international trade, a source of economic growth at the global level, of job and wealth creation, indispensable to the satisfaction of social and human needs. The last decade demonstrates it, even though developing countries were not all able to take advantage of it.”¹⁸⁵ And in 2006, as it seemed that the WTO Doha Round would fail, it noted that such failure “would hit first the three quarters of WTO members, for whom ‘insertion in international trade is the first generator of growth...,’ as Pascal Lamy [president of the WTO] pointed out.”¹⁸⁶

The alternative to protectionism lay in an industrial policy aimed at upgrading so as to compete in the world economy through high value-added production. This strategy is advocated even by the textile-apparel federation Hacuitex in spite of persistent offshoring. According to former Hacuitex Secretary General Martial Videt, who replaced the dissenting leader Daniel Torquéo in 1990, the choice is not between being in favor or against offshoring. He rejects the idea put forward by the Communist Party and the CGT

¹⁸² CFDT, “Adaptation du syndicalisme,” 41th congress of the CFDT, *Syndicalisme*, July 7, 1988, p. 4, 9.

¹⁸³ Jean-François Trogrlic, “Présentation de la résolution sur la mondialisation,” 44th confederal congress of the CFDT, December 11, 1998, p. 4.

¹⁸⁴ CFDT, “Le syndicalisme face au défi de la mondialisation,” 44th confederal congress of the CFDT, *Syndicalisme Hebdo* No. 2709, September 3, 1998, p. 15.

¹⁸⁵ CFDT, “Bilan de Doha: Quatrième réunion ministérielle OMC,” November 2001.

¹⁸⁶ CFDT, “L’échec de l’OMC aggrave le déséquilibre Nord-Sud,” September 6, 2006.

of an anti-offshoring law and stresses instead an industrial strategy that would prevent firms from getting to the point where they need to move offshore.¹⁸⁷ Specifically: “All firms are not condemned to move offshore. Some productions can stay in France, even in a very competitive international environment, but one that requires to move upward in the value chain and make higher value-added products thanks to technology and comparative advantage.”¹⁸⁸ Similarly, Jean-François Trogrlic, head of international affairs at the CFDT, explains that his responsibility as a trade unionist is to “promote reconversion and differentiation strategies as well as the establishment of new firms that will bring other types of value added and become vectors of development and progress.”¹⁸⁹

This perspective supposes that nation-states still have some room for maneuvering. More importantly, it implies a redefinition of state intervention away from the traditional French *dirigiste* pattern. According to the CFDT, the “all mighty state” needs to be replaced with a “strategist state” that will stimulate economic activity and attract foreign direct investment destined to high value-added production through quality public services and infrastructures, a skilled labor force, R&D clusters and innovation, and good industrial relations.¹⁹⁰ Put briefly, the “strategist state” participates not in the supervision of industrial development but in the construction of comparative advantages. Such an approach to the role of the state is congruent with the CFDT’s traditional antistatist stance. The evolution of the CFDT’s demands remained within the bounds of its organizational repertoire.

¹⁸⁷ Martial Videt, “A propos des délocalisations,” *Hacuitex* No. 528, October 1999, p. 2.

¹⁸⁸ Interview with Martial Videt, April 2003.

¹⁸⁹ Interview with author, April 2003.

¹⁹⁰ CFDT, “Le syndicalisme face au défi de la mondialisation,” 44th confederal congress of the CFDT, *Syndicalisme Hebdo* No. 2709, September 3, 1998, p. 6 and 31-32.

Although such an industrial policy would be carried out at the national level, the CFDT believes that today most solutions lie at the supranational level. It has thus supported European integration as an opportunity for France. While in the past it supported it in the hope of seeing the advent of a socialist Europe based on the social ownership of means of production, democratic planning, and self-management, since the early 1980s it has accepted the European Community (EC) a regulated free trade zone with some basic social protection and coordination. Thus, it campaigned in favor of the Maastricht Treaty in 1992 and in favor of the Constitutional Treaty in 2005, and used the framework of the European Union (EU)—such as the “Social Protocol” of the Maastricht Treaty that expanded the EU’s social policy authority or different European directives on layoffs, European work councils, and the legal status of European firms—to develop its strategy and legitimize its demands. It picked up on the European Commission’s talk on “social dialogue” in the late 1980s and early 1990s and made its own.¹⁹¹ The tripartite bodies and social partnership advocated by the Commission obviously matched the CFDT’s “recentreage” strategy and focus on negotiation and the fact that the Commission was headed by Jacques Delors, former CFDT member, facilitated the convergence with the Commissions’ discourse.

The CFDT is a strong supporter of European integration because it believes that it is the only way to defend as well as expand the “European social model” (Notat 1997: 132-33)¹⁹² and, thereby, reconstruct and improve a social regulation that previously existed

¹⁹¹ For a discussion of the European Commission’s discourse and strategy toward trade unions, see Martin and Ross (2001).

¹⁹² Several authors (e.g., Colin Crouch, Bernhard Ebbinghaus, André Sapir) have pointed out that there is not a *single* European model but several types of model in the same way that there are distinct types of European

within national borders. But for the CFDT, European integration is also a means to influence international institutions like the IMF, the World Bank, the WTO, and promote the adoption of global social and environmental norms defined by the International Labor Organization (ILO) and the United Nations (UN): “The stronger Europe will be, the more it will be able to play its role of positive influence on globalization. . . . The European social model, particularly the recognition and practice of social dialogue that it develops, can induce at the global level new modes of functioning that include more closely social partners to multilateral decisions.”¹⁹³

This faith in international institutions is based on the belief that multilateral agreements will always be fairer than bilateral agreements that are generally realized at the expense of developing countries that cannot compete with leading advanced industrial countries. The fairness of multilateral agreements stems from the balance of power that the high number of participating countries yields and the reliance on clear written rules rather than ad hoc negotiations. According to the CFDT, rules-based multilateralism is the first step toward a system of global governance.¹⁹⁴ The CFDT is thus a supporter of what Abdelal and Meunier (2006) call “managed globalization,” an approach developed by French social Catholics close to the CFDT like Jacques Delors and his former assistant and current president of the WTO, Pascal Lamy.

capitalism and welfare state. The CFDT acknowledges this diversity but refers to the European social model to underscore what allegedly distinguishes Europe from the US and Japan.

¹⁹³ CFDT, *Agir sur la mondialisation*, Paris, CFDT, 2002, p. 51. Global norms include core labor standards but also guidelines for ethical investments and consumption as well as corporate social responsibility.

¹⁹⁴ CFDT, “Bilan de Doha: Quatrième réunion ministérielle OMC,” November 2001.

5.3. Alliances and Tactic: Social Concertation and Divergence

The CFDT pursues social dialogue or partnership at both the national and supranational level. It claims that the effectiveness of the industrial policy it advocates requires a synergy between the state, the private sector, and social partners.¹⁹⁵ It sees social concertation not only as a mechanism of coordination but also as a legitimating strategy aimed at making the resulting decisions acceptable to the rank and file as well as the general public and at demonstrating its status as both a representative of workers and the primary interlocutor of employers. Thus, in 1999 the CFDT was the most vocal supporter of the initiative of the national employers' association, the MEDEF (Movement of French Enterprises), to engage in a national social dialogue over the reduction of working time and the management of social protection.¹⁹⁶ Although this episode of "refondation sociale" led only to a few agreements between several national trade unions and employers (particularly on unemployment insurance), it consolidated the position of the CFDT as the primary interlocutor of employers at the national level and as a key player in the management of social protection agencies (Palier 2002: 384).

Moreover, the fact that the CFDT was so willing to participate in such an initiative illustrates the persisting influence of the antistatist and Christian axes of its repertoire. While the latter feeds the belief in peaceful and positive resolution of economic conflict,

¹⁹⁵ CFDT, "Le syndicalisme face au défi de la mondialisation," 44th confederal congress of the CFDT, *Syndicalisme Hebdo* No. 2709, September 3, 1998, p. 32.

¹⁹⁶ This was right after the first 35-hour-week law was passed and many French employers were complaining about its top-down imposition by the state. They also denounced the increasing role of the state in the management of social protection at the expense of social dialogue (Palier 2002: 378). In this respect, their claim resonated with the CFDT's traditional antistatistism, even though the CFDT had been demanding a reduction of working time for more than twenty years.

the former sustains the notion of subsidiarity—namely “that the state should not seek to prescribe employment matters but should leave these to be determined by the ‘social partners’ themselves” (Hyman 2001: 49)—that permeated the “refondation sociale.”

Considering this emphasis on social dialogue and partnership, it is not surprising to see the CFDT competing with the antiglobalization movement through a divergence strategy.¹⁹⁷ Competing through divergence or differentiation implies stressing one’s distinctiveness and underscoring disagreements. Although they share some basic demands, like the cancellation of the third world debt or the global enforcement of labor standards, the core beliefs of the CFDT contradict the statist principles that guide most of the French antiglobalization movement (cf. Chapter 4). Furthermore, the fact that several leaders of the French antiglobalization movement come from the far left, particularly Trotskyite organizations with whom the CFDT had many conflicts over the last thirty years, means that there is a legacy of suspicion and political animosity that thwarts most ad hoc alliance-building efforts.¹⁹⁸ The CFDT claims that it wants to act with NGOs to pressure states, but in practice the only globalization-related campaign in which it actually cooperates with actors of the antiglobalization movement is the one against sweatshops in the textile and apparel industry.¹⁹⁹

¹⁹⁷ Some authors (e.g., Taylor and Mathers 2002) argue that there are two conflictive strategies of labor renewal: social partnership and social movement unionism. The CFDT’s strategy falls in the first category.

¹⁹⁸ For example, during my field research many CFDT leaders of local unions became very suspicious when they learned that I had also been interviewing Trotskyite and SUD militants. A few ones even specified that they did not want me to show my interview notes to SUD militants. I obviously assured them that all the interviews were confidential. Opponents of the official line of the CFDT also have their share of animosity, as some publications indicate (see, for example, the little book published by three former leaders of dissenting factions of the CFDT, including the former Secretary General of the textile-apparel federation of the CFDT, Daniel Torquéo [Aparicio et al 1999]).

¹⁹⁹ The CFDT has been involved in the campaign “De l’éthique sous l’étiquette” (“Ethics under the Label,” the French branch of the global Clean Clothes Campaign) since 1995. In 1998 it also participated in the World March against Child Labor.

At the same time, many members of the CFDT are also members of ATTAC and other antiglobalization organizations. Moreover, remaining dissenting factions inside the CFDT—such as its finance workers federation and, until 2003, transport and equipment workers federation (FGTE-CFDT)—have played an active role in the antiglobalization movement from the beginning. They contributed to launching several mobilization networks and organizations like ATTAC, participate in most protest events, and regularly sign joint communiqués with leading organizations of the movement. Although they have not managed to regain a real influence and make the CFDT depart from the path it had taken in the late 1970s, the antiglobalization movement has exercised real pressure on the confederal leadership of the CFDT. The latter could not simply dismiss it. It has engaged in public debates with public figures like José Bové and leaders of ATTAC, has attended the Porto Alegre World Social Forum, and has published a little brochure to clarify its position toward globalization.²⁰⁰

The CFDT and most organizations of the antiglobalization movement do not compete for members since they operate in distinct institutional arenas. They do, however, compete for legitimacy and influence in public debates. In this competition, each actor stresses distinctive features. The criteria mobilized to assert these differences are not neutral and imply a hierarchy (cf. Barman 2002:1194).

Leading organizations of the antiglobalization movement like ATTAC generally use strict ideological criteria and claim that the CFDT sold out to the market and neoliberalism. The remaining dissenting factions inside the CFDT that are involved in the antiglobalization movement also use ideological criteria to depict the confederal

²⁰⁰ CFDT, *Agir sur la mondialisation*, Paris, CFDT, 2002.

leadership. Such an accusation aims at underscoring their ideological purity and radicality and, thereby, superiority. In contrast, the CFDT deploys organizational (internal democracy and accountability) and information (competence) criteria. It claims that the antiglobalization movement is far from an being example of democracy and legitimacy.²⁰¹ Similarly, it argues that organizations like ATTAC can very well say whatever pleases them because, in contrast to unions, they are not accountable to members and other social actors.²⁰² Insofar as mainstream organizations adopting the divergence strategy hope to prevent challengers from acquiring an institutional legitimacy and becoming regular competitors,²⁰³ they often question the credibility and motives of their adversaries. The most common charge is that of incompetence and ideological blindness. Challengers allegedly do not know what they are talking about, cannot grasp the complexities of the real world, and are stuck in protest instead of making constructive proposals.

For example, in interviews leaders of the CFDT regularly pointed out that they were familiar with the world of labor whereas most militants of the antiglobalization movement knew nothing about it. Former Secretary General of the CFDT Nicole Notat (1997: 123-24) also argues that in politics blaming globalization is the argument “of those that have nothing else to say, that are destitute, worn out.” According to her, if opponents of globalization do not see its benefits it is simply because they are blinded by ideology: “You know the sentence of Jaurès ‘Start from the real to get to the ideal’? Well, in their

²⁰¹ Interview with Jean-François Trogrlic, head of international affairs at the CFDT, April 2003.

²⁰² Interview with Martial Videt, former Secretary General of the textile-apparel federation of the CFDT (Hacuitex) in the 1990s and early 2000s, April 2003.

²⁰³ However, as Meguid (2002: 56) points out, parties who are *not* directly threatened by a given challenger may use the divergence strategy not to marginalize it but instead to boost its electoral performance and thereby undermine the electoral strength of an established party opponent. The basic logic behind such move is that “the enemy of my enemy is my friend.”

case they start from ideology to find the real. Perhaps ideological closure allows you to live happy in your schemas and certitudes but it also prevents you from apprehending the real.”²⁰⁴

In order to make sense of the antiglobalization movement, the confederal leadership of the CFDT has transposed the symbolic boundaries it had developed in the 1980s to isolate the dissenting factions that were challenging it. It thus claims to embody the serious, realistic, and responsible alternative, whereas the antiglobalization movement is allegedly stuck in an “infantile stage,” as Lenin would put it. Whatever “progress” the antiglobalization movement has made, it is thanks to unions like the CFDT. According to Jean-François Trogrlic, head of international affairs at the CFDT:

We have diffused our ideas within the alterglobalization [*altermondialisation*] movement. I’m pretty happy about this. You noticed that now it calls itself *alterglobalization* rather than *antiglobalization*. It is us, the union movement, the Brazilian CUT included, that shaped this evolution. It was the big difference between the first and the second World Social Forum.²⁰⁵

6 | CONCLUSION

A recurrent theme of this chapter has been the CFDT’s relation to capitalism and the state. The CFDT’s opposition to globalization in the 1970s was characterized by both an anticapitalist stance that advocated an alternative model of development and an antistatist

²⁰⁴ Interview with author, June 2003.

²⁰⁵ Interview with author, April 2003. Apparently, this semantic shift means a lot to the social democratic left. I had the opportunity to talk briefly with former socialist Prime Minister Lionel Jospin in 2003, when he gave a talk at MIT after he had lost the 2002 presidential election and retired from politics. He told me exactly the same story, except that in his version it was the Socialist Party that was at the origin of the shift. I present yet another version in Chapter 4 (the movement changed its name for purely strategic reasons, without either unions or parties telling it to do so).

stance that implied an ambiguous refusal of protectionism. During the 1980s, it gradually accepted capitalism and the market while remaining faithful to antistatism. As a result, in the late 1990s the CFDT's position toward globalization was characterized by both a nuanced procapitalist stance that acknowledged the potential gains of free trade and an antistatist perspective that stressed cooperation among social partners rather than top-down state intervention.²⁰⁶ I call this response the adaptation strategy because it no longer aspires to an alternative model of development but instead seeks progressive ways to make the most of globalization.

The CFDT's position toward globalization today could not have been predicted simply by looking at its past record. It could not have been predicted either by looking at the evolution of the social composition of the CFDT. Although today the latter is dominated by federations based in sectors not exposed to foreign competition, such as health, retail, and public services, the respective positions of these federations have evolved over time. For example, the health workers' federation used to be one of the leading dissenting federations up to the late 1980s. Its stance changed as a result of the political-organizational process of closure that I described. Another example showing that there is not a strong correlation between the economic location of a federation and its position toward globalization is the case of the textile-apparel workers' federation Hacuitex. Even though it is composed primarily of low-skilled workers in a sector that has been deeply affected by international trade for several decades, today it stands by the

²⁰⁶ I say “nuanced procapitalist stance” because it stresses varieties of capitalism. It would be thus more accurate to say that it favors a *specific* variety of capitalism—what Hall and Soskice (2001) call “coordinated market economies”—rather than capitalism as such.

confederal leadership and endorses the adaptation strategy. Its stance changed when its leadership changed as result of the process of closure.

Such an emphasis on internal struggles as a determining factor suggests that the position of a given organization reflects the prevailing internal balance of power. It changes “in response *either* to changes in the balance of power among various social actors *or* to changes in the preferences or interests of the most powerful actors” (Thelen 2003: 216). Such an explanation sheds some light on the trajectory of the CFDT. The latter’s position did change because the preferences of the confederal leadership evolved over time as a result of organizational failure. However, we still need to account for the *direction* of change. The CFDT was not predetermined to end up adopting the adaptation strategy. It could have elaborated another strategy.

In this chapter, I have tried to demonstrate that in the case of the CFDT the direction of change stemmed from both the initial conditions of the organization and a specific political process of change and stabilization. Initial conditions refer to the CFDT’s repertoire and linkages. The latter limited the range of possible interpretations and solutions that the CFDT could devise when it experienced organizational failure and underwent a critical juncture.

However, the specific interpretations and solutions do not seat there, waiting to be used. They have to be produced. This is where the mechanism of bricolage comes into play. It embodies the agency of actors as they recombine elements from their organizational repertoire and linkages to solve the problem they face. Bricolage is a political process insofar as actors do not necessarily agree on the best combination of elements. There is often a plurality of competing interpretations and solutions even within

a single organization. The process of change that bricolage initiates can involve a recasting of the actors' self-definition. Such identity shift contributes to pushing the organization in a given direction over another. Finally, in order to exist, a path needs not only to be generated but also reproduced. Otherwise the organization would be changing continuously. In the case of the CFDT, the main mechanism of path stabilization was a closing of the organizational opportunity structure that increased the cost of dissident collective action inside the CFDT.

The adaptation path upon which the CFDT embarked in the late 1970s emerged thus from the cumulative effect of recombinations, struggles, and events, over time. Its basic distinctive qualities first came out during the critical juncture created by organizational failure, but its final shape crystallized incrementally later on. Unintended consequences, like a renewal of competition as a result of closure, accentuated certain of its dimensions well after organizational failure had been resolved.

The Path to Resistance: The Case of the CGT

The General Confederation of Labor (Confédération générale du travail, CGT), France's oldest and, up to the mid 1990s, biggest trade union organization,²⁰⁷ exemplifies the resistance strategy. It depicts globalization not as a fact that requires adaptation but as a neoliberal project that must be resisted. It blames it for boosting social inequalities and undermining democracy, and demands the protection of national industries, the defense of social rights, and the reform of international institutions. Finally, it implies investing resources in alliance building with extra-institutional challengers and converging with the antiglobalization movement so as to develop a social front against global market forces and their allies.

Neoclassical trade models (cf. Frieden 1991, Hiscox 2002, Rogowski 1989) are not very useful to explain the CGT's current response to globalization because since the 1990s the CGT's constituency has been primarily located in large, semi-public firms (EDF, SNCF, RATP) that enjoy a monopoly as well as in public (public administration, postal workers, health workers) and private (retail, distribution) services, that is, in sectors neither

²⁰⁷ However, a recent study (Andolfatto and Labbé 2007) estimates that the CGT, with 525,000 members, is the largest French trade union organization anew. This estimate is substantially inferior to the official number reported by the CGT (710,000).

exposed to foreign competition nor threatened by offshoring.²⁰⁸ If CGT members oppose globalization it is not necessarily because their jobs are directly affected by it but because they believe that it entails pressures on the state to privatize public services and reform welfare benefits as well as labor markets.

Institutionalist accounts stressing the effects of historical cleavages in which organizations are embedded (cf. Ebbinghaus and Visser 2000, Lipset and Rokkan 1990, Marks and Wilson 2000) can shed some light on the CGT's resistance strategy. Cleavage embeddedness implies that organizations interpret social reality through stable prisms and dispositions that shape their behavior. According to this approach, the CGT's opposition to globalization stems from the class cleavage and the reform-revolution cleavage and should have been constant since that organization first started to deal with the issue of trade and economic integration in the late nineteenth and early twentieth centuries. The CGT's resistance strategy was thus allegedly predictable. Although these cleavages have undoubtedly shaped the CGT, institutionalist approaches overstress continuity. As Suzanne Berger (2003: 55) has shown, before World War I the CGT actually opposed protectionism in the name of international working-class solidarity and because of its negative effect on the cost of life for French workers. Furthermore, even though the CGT has opposed free trade and global economic integration since World War II, it has done so for different reasons and through different strategies. These changing reasons and strategies are not mere noise that prevent us from seeing underlying regularities but actually make up the substance of the politics of globalization.

²⁰⁸ In 1996-98, public services, postal workers, health workers, energy (e.g., EDF), and rail workers ("cheminots," that is, SNCF, RATP) represented 42.9 percent of all CGT members; in contrast, the CGT metalworkers federation had decreased to 10 percent of the total membership (Andolfatto 2001: 69).

We can distinguish two phases in the CGT's response to globalization since World War II. The first one was characterized by what I call a radical strategy that implied an offensive class-based, anticapitalist posture, subordinated to the political agenda of the French Communist Party (PCF). It aimed at replacing capitalism with a socialist mode of production through the nationalization of leading private firms. This radical strategy lasted from the late 1940s to the mid-late 1980s and culminated in the CGT's enthusiastic support of the Common Program of the left in the 1970s. It was closely intertwined with a resource mobilization pattern that exemplified the golden age of class politics. It relied on politicized working-class identities, class struggle, and strong party-union linkages.

The second phase stemmed from the erosion of the radical strategy. It is characterized by the resistance strategy that I introduced above. Rather than embodying a clear plan, the resistance strategy that emerged in the early 1990s represents an effort—almost desperate—to adjust to the new political and socio-economic environment of French trade unions. It was formed gradually through successive steps taken by the CGT as it faced organizational failure. In this new phase, the CGT no longer relies exclusively on class politics to mobilize resources. It progressively abandoned its historical alliance with the PCF and reframed its identity and claims so as to attempt to build new linkages and alliances that allowed it to tap new resources.

Therefore, as in the case of the CFDT, the CGT's current response to globalization cannot be simply deduced from its social composition or past positions and practices. We need to take into account organizational factors and dynamics and trace its formation over time as the CGT departed from its previous path. This chapter analyses the CGT's response to globalization as a gradual reaction to a structural challenge that the CGT

confronted in the 1980s and that translated into organizational failure. The CGT's reaction to this challenge was shaped by its organizational repertoire and organizational linkages. In contrast to the case of the CFDT, in which a critical juncture is clearly identifiable, the evolution of the CGT is characterized by an incremental process combining elements of what Streeck and Thelen (2005) call drift and layering. Subsequently, the competitive challenge that emerged in the late 1990s reinforced the path that the CGT had taken when it reacted to the structural challenge.

In order to trace this process, I will first present key organizational characteristics of the CGT, namely its organizational repertoire and linkages. Second, I will describe the CGT's response to globalization in the 1970s and early 1980s, at the peak of class politics. Third, I will show how the CGT experienced the structural challenge and the concomitant organizational failure. Four, I will explain how the CGT reacted to this challenge through a process of drift and layering and I will apply the three central mechanisms that structured this process: bricolage, identity shift, and opening. And finally, I will describe the CGT's current response to globalization as a result of the process of change triggered by the structural challenge of the 1980s.

1 | THE ORGANIZATIONAL CHARACTERISTICS OF THE CGT

The CGT was founded in 1895 and underwent several schisms and mergers to finally stabilize after 1947, once the PCF took over and its reformist anti-communist faction left to create CGT-FO. The CGT was a key actor in the consolidation of the class cleavage and the reform-revolution cleavage in France. Together with the French Section of the Socialist

International (SFIO) and then the PCF, it built a subculture sustained by dense personal and interorganizational networks that some authors characterized as an “ecosystem” (cf. Lavau 1981). The CGT embodied industrial blue-collar unionism through much of the twentieth century. In 1976, when it still had almost a million and half members (twice as many as the CFDT), its metalworkers’ federation represented 20.4 percent of its total membership. Other leading industrial federations (railworkers, books and paste workers, postal and communication workers, etc.) stood far away behind, with between 6 and 5 percent of the total membership (Andolfatto 2001: 69). Throughout the “trente glorieuses” (1945-75) the Renault autoworkers of the Billancourt plant, on the outskirts of Paris, symbolized this blue-collar, working-class identity.

This historic role and development entailed a particular organizational repertoire as well as set of linkages that deeply shaped the CGT’s intervention in industrial relations and public affairs. This section briefly lays out these two aspects.

1.1. The Organizational Repertoire

The organizational repertoire of the CGT—that is, the relatively stable cultural materials that members of the CGT can use to define their collective identity and interpret social reality as well as engage in the industrial relations arena and politics—originally drew from two distinct and yet complementary traditions: Communism and nationalism.²⁰⁹

²⁰⁹ Originally, the CGT also heavily drew upon anarcho-unionism. However, this source was marginalized between the two world wars, as communists became the dominant faction of the CGT. Similarly, there was a reformist faction but it did not leave a deep imprint on the organizational repertoire of the CGT and left the organization in 1947, with the beginning of the Cold War.

The communist tradition took hold with the rise of the PCF and entailed a lasting influence of Marxist-Leninism. It implied seeing industrial relations as class warfare between the bourgeoisie and the proletariat. Starting in 1936 and throughout much of the twentieth century, the CGT thus defined itself as a mass and class-based trade union (“syndicat de masse et de classe”). Even though these labels have evolved over time (from proletariat to workers and then citizens or people; from bourgeoisie to capitalists and then market forces), the communist tradition consistently depicted society as an ongoing polarized struggle between two fundamental social groups and the CGT built its collective identity and strategy on this conception of anticapitalist class struggle. Hence its rejection of social concertation and partnership as class collaboration and its enduring preference for confrontation, national protest days, and strikes. The communist tradition, in its Marxist-Leninist version, also implied a faith in a model of development celebrating industrial production and technology at the expense of qualitative concerns (e.g., alienation). In this respect, the CGT departed from the CFDT’s emphasis on the cultural foundations of socio-political change.

The CGT’s organizational repertoire also drew from French nationalism, not the ethnic nationalism that came to the forefront of public debates during the Dreyfus Affair in the 1890s and subsequently supported the Vichy Regime during WWII, but the civic and collectivistic nationalism of the French Revolution (Jacobinism) and the Resistance against the Nazis. Civic-collectivistic nationalism assumes that one’s first loyalty ought to be directed toward the nation defined in civic and republican terms and understood as a whole

endowed with its own will (Greenfeld 1992).²¹⁰ The CGT first drew from this tradition during WWI, when it decided to support the French war effort. However, it is during WWII that this tradition acquired a lasting influence in the CGT's repertoire, as the CGT developed a class-oriented patriotic discourse and participated in national alliances.

Although it may seem contradictory to draw simultaneously from communism and civic-collectivistic nationalism, the two turned out to be actually quite compatible in practice. The CGT simply depicted French workers as the embodiment of the nation and the general interest. Inversely, it often referred to "cosmopolitan capital," thereby suggesting an opposition between rooted French workers and rootless capitalists. Capitalism had to be opposed not only because it undermined the interests of the working class but also because it was anti-national. Similarly, the state had to be seized not only because it was a necessary step toward socialism but also because only the state could supervise economic development for the benefit of the country rather than a single class.

For example, the CGT strongly supported the reconstruction efforts and the nationalization of leading firms after WWII,²¹¹ denounced the Marshall Plan and later European integration as a product of capitalism and American imperialism, and campaigned in favor of French consumption ("Buy French" campaign)²¹² and production ("Made in France" campaign) in the late 1970s and early 1980s. Similarly, it adopted a

²¹⁰ Liah Greenfeld (1992) distinguishes three ideal-types of nationalism: Ethnic, civic-individualistic, and civic-collectivistic.

²¹¹ The CGT did not originally advocate nationalizations; it started doing so during its involvement in the Resistance (Groux and Mouriaux 1992: 247).

²¹² There was even a "smoke French" campaign (Mouriaux 1982: 186).

strong anti-American posture in the name of anticapitalism and anti-imperialism and for the sake of the defense of working-class interests and national sovereignty.²¹³

Insofar as it drew from the communist and nationalist traditions, the CGT's organizational repertoire became structured around two axes: *anticapitalism* and *statism*. The CGT turned nationalizations and then the defense of public monopolies and state intervention into the cornerstone of its participation in public debates. This coherence involved a strong homogeneity and, thereby, limited alternative resources to which the CGT could turn to cope with uncertainty or a crisis. Insofar as having a homogeneous repertoire reduces the range of potential recombinations and the possibility of innovation (cf. Crouch 2005, Crouch and Farrell 2004), the CGT had little room for maneuvering and adjusting to environmental changes.

1.2. Organizational Linkages

Organizational linkages condition the access to resources. They are defined by their strength (weak/strong) and breadth (single/multiple) (Aveni 1978). In the late 1970s and early 1980s, when the CGT began to face organizational failure, it had a single strong linkage with the PCF.

Although in 1906 the CGT adopted the Amiens Charter, which requested trade unions to be autonomous from and even have primacy over political parties, it gradually became closely intertwined with the PCF, and by the late 1940s the PCF actually

²¹³ The CGT thus drew on two types of anti-Americanism: Sovereignist anti-Americanism and social anti-Americanism (cf. Meunier 2005).

controlled the CGT. The two organizations were linked by informal but nonetheless institutionalized ties that gave to the PCF the ability to weight heavily in the CGT's decision-making process. Almost all important CGT leaders have been prominent PCF figures and the Party controlled almost all industrial federations of the CGT, consistently had a majority at the CGT Confederal Bureau (sort of executive parliament of the organization), and regularly discussed internal matters of the CGT during the meetings of its Political Bureau (Ross 1975). According to Andolfatto and Labbé (1997: 68), the more one went up in the CGT's hierarchy, the more communists there were. Between 1946 and 1959, one out of four or five CGT officials (*cadres*) was also an official of the PCF; in the 1990s, almost 10 percent of the members of the Executive Commission of the CGT and 25 percent of the members of the Confederal Bureau of the CGT also sat on the National Committee of the PCF (Andolfatto and Labbé 1997: 173).

However, in the 1970s Ross (1975: 505) claimed that "If the organizational relationship between the PCF and the CGT has not changed *in form* since the early postwar period, the same cannot be said for its *content*." Ross (1975: 536-37) argued that this organizational relation went from a Leninist "transmission belt" model (i.e., complete subordination of the CGT to the PCF's agenda and strategy) in the late 1940s and early 1950s to a "two-sphere" model (division of labor between the two, with the PCF focusing on politics and the CGT depoliticizing so as to concentrate on the labor market) in the 1960s and early 1970s. But even the "two-sphere" model put limits on the CGT autonomy, as the CGT could not challenge the PCF (Ross 1975: 540).

Such a strong organizational linkage with the PCF had three immediate consequences. First, it shaped the CGT's organizational repertoire and, thereby, its

interpretation of society and the economy as well as its tactics. Second, it became an object of disagreements and divisions inside the CGT (Bridgford 1991: 106-115), as a minority criticized the PCF's leverage over the CGT as well as its positions toward the Soviet invasion of Afghanistan in 1979 and the rise of Solidarity in Poland in 1980. And third, it contributed to the division of the French labor movement. During the peak of the Cold War, the CGT remained isolated and even when the political context got more favorable, in the late 1960s and 1970s, its tactic of "unity in action" with the CFDT never entailed the construction of new strong linkages (Ross 1982). Political divisions and organizational competition prevailed. Similarly, in contrast to the CFDT, the CGT never developed linkages with social movement organizations. It saw social movements as suspiciously autonomous and leftist (as indicates the CGT's reaction to the events of May 1968) and was convinced that building alliances and/or linkages with them would be a waste of time and resources. Like the PCF, the CGT thought of itself as an avant-garde that others had to follow.²¹⁴

The CGT had thus a single and strong organizational linkage. Although this linkage implied a substantial and stable flow of resources, it also prevented the CGT from developing enduring relations with other organizations that would have allowed it to diversify its access to resources. This situation of monopoly accentuated the homogeneity of the CGT's organizational repertoire and greatly reduced the flexibility of the CGT's leadership and, thereby, its capacity to adjust to changes in its environment.

²¹⁴ This "avant-garde complex" is incredibly persistent. For example, the head of the globalization commission of the PCF explained that in the late 1990s the PCF was very suspicious of the antiglobalization movement: "We, the Communist Party, are the avant-garde of the transformation of society, we are the best anticapitalist. It is not these guys [i.e., the antiglobalization movement] that will tell us how things work and what to do." Interview with author, July 2002.

2 | RESPONSES TO GLOBALIZATION IN THE ERA OF CLASS POLITICS: THE RADICAL STRATEGY

The organizational repertoire and linkages of the CGT shaped its understanding of the international economy and led it to favor what I call a radical strategy. The latter was radical because the CGT believed that the only viable and real solution to the problems of French society laid in a radical transformation or rupture. Capitalism could not be improved or reformed; it could only be replaced with socialism. Hence the emphasis on political rather than socio-economic intervention.²¹⁵ This strategy was offensive insofar as it implied pooling resources so as to take advantage of political opportunities (cf. Tilly 1978: 74) that depended on party-union linkages and electoral cycles. In the era of class politics, the radical strategy was at the core of the CGT's response to globalization. This section first presents the CGT's interpretation of the international economy and then lays out its demands and tactics.

2.1. Interpreting the International Economy

In the 1970s, the CGT's interpretation of the international economy was primarily shaped by the Marxist anticapitalist and patriotic axes of its organizational repertoire. It saw the growing internationalization of the economy as partaking in a trend that emerged after

²¹⁵ These characteristics led Lange et al (1982a : 10) to label the French union movement's response to the economic crisis of the 1970s as "maximalist."

World War II with the end of colonialism and the transformation of capitalism.²¹⁶ According to the CGT, globalization was inherent in the growth of productive forces, which in turn, stemmed from scientific and technological progress. “It is an objective trend and necessity of the development stage that many countries have reached.”²¹⁷ But the development of productive forces was not the only driver of globalization. Leading firms supported by the state were central actors in this process.

Indeed, the CGT’s interpretation of the international economy was also deeply influenced by the CGT’s strong organizational linkage with the PCF. It built on the PCF’s “state monopoly capitalism” (SMC) theory. According to this theory, capitalism had reached a stage characterized by a concentration of capital and production, the reinforcement of state intervention in the economy, and the systematic export of capital (Pouch 2001: 53).²¹⁸ The PCF and the CGT thought that the French economy and the French state were dominated by a “monopoly caste,” that is, a fraction of the bourgeoisie controlling the monopoly sector (Ross 1982: 30). As nation-states separately facilitated capitalist monopoly accumulation, they fostered the internationalization of capital.

The CGT questioned the claim according to which the government was not responsible for France’s problems.²¹⁹ It blamed the Gaullist development strategy of the

²¹⁶ The word “globalization” (*mondialisation*) appeared in the CGT newspaper *Le Peuple* in March 1973 but was seldom used. The CGT referred primarily to the internationalization of capital and production, international trade, and imperialism.

²¹⁷ CGT, “La CGT et les sociétés multinationales,” *Le Peuple* No. 914, March 16-31, 1973, p. 14.

²¹⁸ Thierry Pouch (2001: 52) explains that the PCF favored the SMC theory so as to distinguish itself from Stalinism and the old “pauperization” theory of the 1950s. The golden age of SMC theory was from 1966 to late 1970s; the main economist associated with it was Paul Boccara.

²¹⁹ Jean-Louis Moynet, “La crise de structure du capitalisme s’approfondit: La seule issue réside dans le Programme Commun,” *Le Peuple* No. 933, January 16-31, 1974, p. 4. Moynet’s report was adopted by the CGT’s Executive Commission.

1960s for having turned France into an intermediary country in the international division of labor (Ross 1982: 46). France could not compete with the US, Japan, and West Germany, bemoaned the CGT. State monopoly capitalism had favored the expansion of French monopolies into multinational corporations (MNCs) at the expense of France. The French state had played the role of an “accelerator” through its policy favoring the creation of one or two firms in each sector that could become MNCs.²²⁰ The “industrial redeployment” strategy implemented by the French government had perhaps improved the competitiveness of French MNCs but it had done so at the expense of the French domestically oriented producers as well as French consumers and workers. The CGT believed that the eventual result of this state-led insertion in the international economy would be an increased dependence on foreign technology and capital.²²¹

The key actors of this phase of capitalist internationalization were MNCs. The latter’s expansion accentuated all the effects and tensions of state monopoly capitalism. In 1973, during an international conference on MNCs organized by Chilean trade unions, Henri Krasucki, who would become Secretary General of the CGT in 1982, stated:

Instrument of the monopolistic concentration at the international level, today’s means of imperialism, driven by an endless thirst for profit, MNCs have, through their actions, frightening consequences: They deepen the exploitation of workers in all the countries where they operate and are a means of the anti-trade union struggle. Betting on the competition between workers, they exert downward pressures on salaries, working conditions, employment, and labor rights. They are an instrument of neo-colonialism . . . they are a threat to the independence of peoples and nations—developed or not.²²²

²²⁰ CGT, “La CGT et les sociétés multinationales,” *Le Peuple* No. 914, March 16-31, 1973, p. 16.

²²¹ CGT-CCEE, *L’industrie française depuis 1958, un bilan accusateur* (Paris : CGT-CCEE, 1978) : 220, quoted in Ross (1982: 48).

²²² Henri Krasucki, “Les sociétés multinationales portent au plus haut niveau les contradictions d’une société capitaliste en crise,” *Le Peuple* No. 920, June 15-30 1973, p. 18.

According to the CGT, the development of MNCs also generated increased employment insecurity because they could close and move plants almost at will. The location of their operations was dictated by the quest for all forms of comparative advantages, particularly labor cost, suppliers, transports, financing possibilities, fiscal policy, etc. Although they created jobs in the countries where they invested, they also often put local firms out of business, thereby contributing to unemployment. Furthermore, MNCs exported toward France the goods manufactured offshore, thereby increasing their profit margin. MNCs brought about regional disequilibria, monetary instability, thwarted popular consumption, exerted downward pressures on public spending, etc.²²³ Put briefly in today's language, MNCs fostered a race to the bottom at the expense of workers, national sovereignty, and international stability.

This trend was accentuated, the CGT claimed, by MNCs' refusal to enforce international labor standards defined by the International Labor Organization (ILO). The CGT contended that instead of fostering employment and growth as they claimed, MNCs actually blackmailed developing countries, using the threat to withdraw their investments to violate basic labor regulations.²²⁴ However, the CGT also rejected the incipient campaign on international codes of conduct on grounds that they would be inefficient and would not solve the contradiction between the internationalization of capital and national interests.²²⁵

²²³ CGT, "La CGT et les sociétés multinationales," *Le Peuple* No. 914, March 16-31, 1973, p. 13.

²²⁴ CGT, "La CGT et les sociétés multinationales," *Le Peuple* No. 914, March 16-31, 1973, p. 13.

²²⁵ Jean Magniadas, "Le nouvel ordre économique international: Une exigence qui conserve toute sa force pour sortir de la crise," *Le Peuple* No. 1176, June 21, 1984, p. 34.

The CGT also blamed international trade for the rise of unemployment in France, particularly in sectors like textile and apparel. On the other hand, it depicted trade relations with developing countries as a form of neo-colonialism. It acknowledged that the terms of trade were unfavorable to developing countries, as the price of raw materials and agricultural products dropped. Moreover, slow growth and austerity policies in advanced capitalist countries had a negative impact on third-world exports.²²⁶

2.2. Demands

The CGT's demands were also conditioned by the organizational repertoire and linkages of the CGT. They were framed in terms of class struggle and civic nationalism and subordinated to the agenda and strategy of the PCF. The CGT rejected tripartite concertation (state, labor, and capital) and participation in firm management on grounds that it entailed class collaboration. It neglected the industrial relations arena as a space to formulate solutions to workers' problems and instead invested all its hopes and energy in political and national solutions. Its demands depended on the electoral victory of the PCF.

The CGT believed that the only way to regulate the internationalization of capital and the practices of MNCs for the benefit of French workers was the transition to socialism. This was the main goal of the Common Program endorsed by the PS and the PCF in 1972 and advocated throughout much of the 1970s. One of the Program's core demands on which the CGT systematically insisted was the nationalization of leading

²²⁶ CGT, "Pour des rapports nouveaux entre la CEE et les pays en voie de développement," *Le Peuple* No. 947, July 16-August 15, 1974, p. 22; Georges Ségué, CGT, "Pour un nouvel ordre international," *Le Peuple* No. 1059, April 15-30, 1979, p. 14-15; Jean Magniadas, "Le nouvel ordre économique international: Une exigence qui conserve toute sa force pour sortir de la crise," *Le Peuple* No. 1176, June 21, 1984, p. 32.

firms in industrial and financial sectors. Nationalized firms would give priority to French workers and the internal market and prevent the subordination of entire economic sectors to foreign capital. Nationalizations would allegedly allow the government to create jobs, answer workers' needs, develop a new industrial policy focused on high-tech products, and ensure national independence in terms of defense, steel, chemistry, and pharmaceuticals.²²⁷ Nationalizations enjoyed a strong legitimacy in France and the CGT ruled out the claim that external constraints could make them difficult to implement.²²⁸ Faith in their positive effect rested on the patriotic dimension of the CGT's repertoire and on the perception that the state was an instrument of the bourgeoisie and its monopolies.

In addition to nationalizations, the CGT advocated the public and democratic control of inward and outward FDI flows, the government's right to orient FDI toward sectors and regions of its choosing and force MNCs to invest their profits in the country where have been made, the creation of international representation boards within MNCs (like work councils) so that workers can have access to information and engage in international collective bargaining, and the enforcement of ILO labor standards.²²⁹ It claimed that the state should survey all firms and sectors to determine the origins of imports and whether they are excessive and then take measures to protect and boost French

²²⁷ CGT, "Nationalisations," *Le Peuple* No. 1113, August 16-31, 1981, p. 7.

²²⁸ Jean-Louis Moynet, "La crise de structure du capitalisme s'approfondit: La seule issue reside dans le Programme Commun," *Le Peuple* No. 933, January 16-31, 1974, p. 4. Moynet's report was adopted by the CGT's Executive Commission. At the time, the idea that external constraints were a myth introduced by capitalists to discourage structural reforms was quite common among the left.

²²⁹ CGT, "Position de la CGT en ce qui concerne les sociétés multinationales," *Le Peuple* No. 947, July 16-August 15, 1974, p. 17; CGT, "La CGT propose des mesures justes et efficaces pour lutter contre l'inflation, le chômage, le déficit du commerce extérieur," *Le Peuple* No. 1152, April 1-15, 1983, p. 8; Ross (1982: 49).

production.²³⁰ It did not matter if such policies had protectionist implications: “To those that will tell us ‘you are protectionists,’ we will answer: ‘If being protectionist means giving oneself the means to fight unemployment, to create jobs, to establish new norms of economic cooperation at the international level, then we are protectionists!’ Hundreds and hundreds of jobs can be created if we force employers to invest in France.”²³¹

Similarly, the textile industrial federation of the CGT argued that there was no reason to let textile industries move to developing countries and rely on them to satisfy French needs:

Why should we dress—something as vital for any French as eating and housing—with foreign products? Would anyone think about importing the bread and water that we need everyday? Surely not. If we import so many textile products, it is thus because some benefit at the obvious expense of each person. . . . it is absurd, unbearable, and therefore unacceptable, to import as many foreign textile products that we can very well produce in France to satisfy the daily vital needs of each person.²³²

European integration was seen as part of the problem rather than the solution. The CGT accused the Common Market of undermining national sovereignty and fostering unemployment, inflation, and a race to the bottom at the expense of working conditions, while private interests made huge profits.²³³ It depicted European integration as a political project driven by American imperialism, national monopolies, and MNCs.²³⁴ Rather than

²³⁰ CGT, “La CGT propose des mesures justes et efficaces pour lutter contre l’inflation, le chômage, le déficit du commerce extérieur,” *Le Peuple* No. 1152, April 1-15, 1983, p. 8.

²³¹ Jean-Dominique Simopoli, “Made in France: Des emplois pour les jeunes, des emplois pour la France,” *Le Peuple* No. 1152, April 1-15, 1983, p. 11.

²³² Jean Trioux, “Le textile peut et doit vivre,” *Le Peuple* No. 1008, February 15-28, 1977, p. 4.

²³³ CGT’s Executive Commission, “Sur le projet d’Europe supra-nationale,” *Le Peuple* No. 983, February 15-25, 1976, p. 3.

²³⁴ Joannès Galland, “L’Europe: Rapport du bureau confédéral présenté à la Commission Exécutive du 6 mars 1979,” *Le Peuple* No. 1058, April 1-15, 1979, p. 5.

being a barrier to the domination of American capital, the European Economic Community actually attracted American investments. The only conceivable Europe for the CGT was a socialist Europe.

The CGT acknowledged that France could not live in autarky and that countries needed to engage in trade to develop, but it also advocated a radical reorientation of French trade and international relations toward developing and socialist countries. Such reorientation would also prevent the international reactions that the implementation of the Common Program could entail. As part of this reorientation, the CGT introduced the idea of “co-development” between developed and developing countries, that is, a form of cooperation supporting the coexistence of different models of development, including self-centered and socialist models.²³⁵ The CGT did not specify how such international cooperation would work, but it did cite the Soviet-controlled Council for Mutual Economic Assistance (COMECON) as a model worth considering to understanding the full potential of win-win cooperation.²³⁶ It also contended that the New International Economic Order (NIEO) introduced at the United Nations’ General Assembly in the mid 1970s fitted to the evolution of productive forces and would foster an international division of labor freed from capitalist domination.²³⁷

Finally, the CGT demanded the democratization of international institutions, particularly the IMF and the World Bank, so that development, growth, and employment,

²³⁵ Jean Magniadas, “Le nouvel ordre économique international: Une exigence qui conserve toute sa force pour sortir de la crise,” *Le Peuple* No. 1176, June 21, 1984, p. 36.

²³⁶ Jean Magniadas, “Le nouvel ordre économique international,” p. 37.

²³⁷ Jean Magniadas, “Le nouvel ordre économique international,” p. 31.

would become priorities of these institutions.²³⁸ As in the case of international cooperation, the specific reforms were not substantially specified. They were not a priority of the CGT's demands. Moreover, the CGT claimed that the best thing workers could do to build a new international economic order was to struggle in their own country against policies driven by the interests of MNCs and in favor of socialism.²³⁹

2.3. Alliances and Tactics

Although in the 1960s the CGT embraced a strict division of labor with the PCF (cf. Ross' [1975] "two-sphere" model), it remained nonetheless subordinated to the PCF's agenda and strategy. It enthusiastically supported the Common Program, elaborated and signed in 1972 by the PS and the PCF, as the best way to defend workers' interests and initiate the transition to socialism. The realization of trade union demands required thus the electoral victory of a political coalition (the Union of the Left).

In order to facilitate this victory, the CGT competed with the CFDT through a convergence strategy. It downplayed differences, stressed common concerns, and attempted to consolidate ad-hoc alliances with the CFDT. In December 1970, the CGT and the CFDT signed a new unity-in-action agreement that focused on five basic issues (wages, retirement age, work week, employment security, and trade union rights). But in spite of its symbolic dimension, this agreement did not specify the tactics to be used (Ross 1975:

²³⁸ Jean Magniadas, "Le nouvel ordre économique international," p. 36.

²³⁹ Jean Magniadas, "Le nouvel ordre économique international," p. 35.

533). This omission was voluntary, as both organizations knew that the issue of tactics would undermine the achieved unity.

The disagreement over tactics directly stemmed from the respective repertoire and linkages of each organization.²⁴⁰ Insofar as the CGT drew on statism and did not believe it could really benefit from its involvement in the industrial relations arena, it favored national days of protest (*journées d'action*) so as to politicize as much as possible local labor-market issues and feed general discontent for the electoral benefit of the PCF (Ross 1979: 48-50). This tactic fitted the “two-sphere” model. In contrast, insofar as the CFDT drew on antistatism and did not have strong linkages with leftwing political parties, it was critical toward the Common Program and reluctant to rely on an electoral victory of the left. Moreover, it thought that national days of protest were “ritual occurrences” that used too much energy for little results (Ross 1979: 49). Disagreements over tactics quickly paralyzed further cooperation between the CGT and the CFDT. Even though it had denounced worker self-management in the late 1960s and early 1970s, the CGT began to refer to it in the late 1970s so as to undermine the progression of the CFDT but, like the PCF who had also picked up the issue in the mid-1970s after having dropped the dictatorship of the proletariat, it had little credibility in this respect (Dandé 2003).²⁴¹

Throughout the 1970s, the dominant tactic of the CGT to implement its radical strategy and fight against globalization was to foster the electoral victory of the Union of

²⁴⁰ One could add that the CGT and the CFDT relied on different repertoires of collective action in Charles Tilly's sense, that is, familiar modes of organizing and acting to which people turn, even though “in principle some unfamiliar form of action would serve their interests much better” (Tilly 1986: 4).

²⁴¹ However, for the PCF and the CGT “self-management” referred to the democratic management of nationalized firms rather than the workers' direct control of firms advocated by the CFDT.

the Left. This tactic was strictly conceived in anticapitalist and national terms and completely derived from the CGT's strong linkage with the PCF.

3 | ORGANIZATIONAL FAILURE: EXPERIENCING THE STRUCTURAL CHALLENGE

The organizational failure of the CGT—that is, its inability to mobilize critical resources and ensure the cooperation of its members—began in the late 1970s and involved an internal legitimacy crisis and a societal legitimacy crisis. The decline of the PCF, which took place simultaneously, both accentuated organizational failure and opened opportunities for dealing with it and adjusting to the new environment. This section discusses each crisis successively.

3.1. The Internal Legitimacy Crisis

The internal legitimacy crisis began in 1978, after the unexpected loss of the left in the legislative elections. The CGT had invested so much energy and resources in the support of the Common Program that the electoral defeat triggered an important debate about its autonomy vis-à-vis the PCF and the proper strategy to follow. Insofar as there are already several accounts of this debate (Bridgford 1991, Mouriaux 1982, Ross 1982), I highlight two points.

First, several CGT officials that criticized their organizations' position (aligned on the PCF's pro-Soviet line) toward Afghanistan and Poland also tried to develop a new

strategy to deal with the economic crisis of the 1970s and the political-economy in general. This strategy departed from the traditional strategy of the CGT in that it advocated change through labor market activism rather than electoral politics and attempted to articulate industrial propositions and countersolutions to shape socio-economic change rather than just defensively resist the social consequences of the economic crisis (Ross 1982: 61). This strategy implied taking change in its own hands rather than depending on the PCF. It benefited from the support of important segments of the CGT, particularly the metalworkers industrial federation.

Although this debate involved communists on both sides, it was a direct challenge to the PCF, which soon cut it short. In 1982, Georges Séguy, the Secretary General of CGT that had tolerated internal debate and dissent, was replaced with Henri Krasucki, whom represented the traditional, orthodox line of the CGT and was close to the leader of the PCF, Georges Marchais. The proponents of the new strategy were accused of factionalism; the ones that sat on the Confederal Bureau of the CGT (e.g., René Buhl, Jean-Louis Moynot) resigned and they were replaced with conservative militants (Andolfatto and Labbé 2006a: 330).

However, the limited autonomy of the CGT remained a recurrent issue. Even though it did not always turn into an open crisis, it fed a latent tension that regularly surfaced when the two organizations disagreed. Therefore, the internal legitimacy crisis of the CGT was never really solved. The strong organizational linkage that tied it to the PCF entailed a co-evolution: The CGT could not engage in substantial organizational reforms as long as the PCF itself did not change.

3.2. The Societal Legitimacy Crisis

The societal legitimacy crisis of the CGT emerged in the late 1970s. Its main indicators were the drop of the CGT's membership and the declining performance of the CGT in professional elections like work councils (*comités d'entreprise*). The former illustrates decline in absolute terms whereas the latter expresses the organization's appeal in comparative perspective. After reaching a peak in 1973, the membership of the CGT began to decrease systematically (see Table 6.1 and Figures 6.1 and 6.2).

Table 6.1: Total Membership of the CGT, 1960-1995 ²⁴²

Year	Total Membership	Year	Total Membership	Year	Total Membership
1960	1,304,000	1972	1,575,000	1984	817,000
1961	1,372,000	1973	1,642,000	1985	707,000
1962	1,205,000	1974	1,588,000	1986	603,000
1963	1,347,000	1975	1,571,000	1987	571,000
1964	1,351,000	1976	1,419,000	1988	539,000
1965	1,359,000	1977	1,450,000	1989	515,000
1966	1,262,000	1978	1,355,000	1990	475,000
1967	1,268,000	1979	1,174,000	1991	468,000
1968	1,392,000	1980	1,121,000	1992	485,000
1969	1,675,000	1981	1,088,000	1993	480,000
1970	1,620,000	1982	978,000	1994	485,000
1971	1,575,000	1983	895,000	1995	450,000

Sources: Visser (2000: 276-277).

²⁴² It is notoriously difficult to obtain reliable data on union membership. The official data that unions provide is generally overblown. Andolfatto and Labbé (1997: 232) calculated the CGT's membership on the basis of the payment of membership dues nine times a year and reached the conclusion that the official data was on average 21 percent higher than the actual numbers (the difference between official and calculated membership is illustrated in Figure 6.2). The data from Visser cited here does not exactly match the calculations of Andolfatto and Labbé (1997) but the gap is minor. I decided to rely on Visser because he provides data on all leading trade union organizations in France from the 1960s to the 1990s.

Figure 6.1: Total Membership of the CGT, 1960-1995



Source: Visser (2000: 276-277).

Figure 6.2: Total Membership of the CGT, 1945-2005 (1,000)

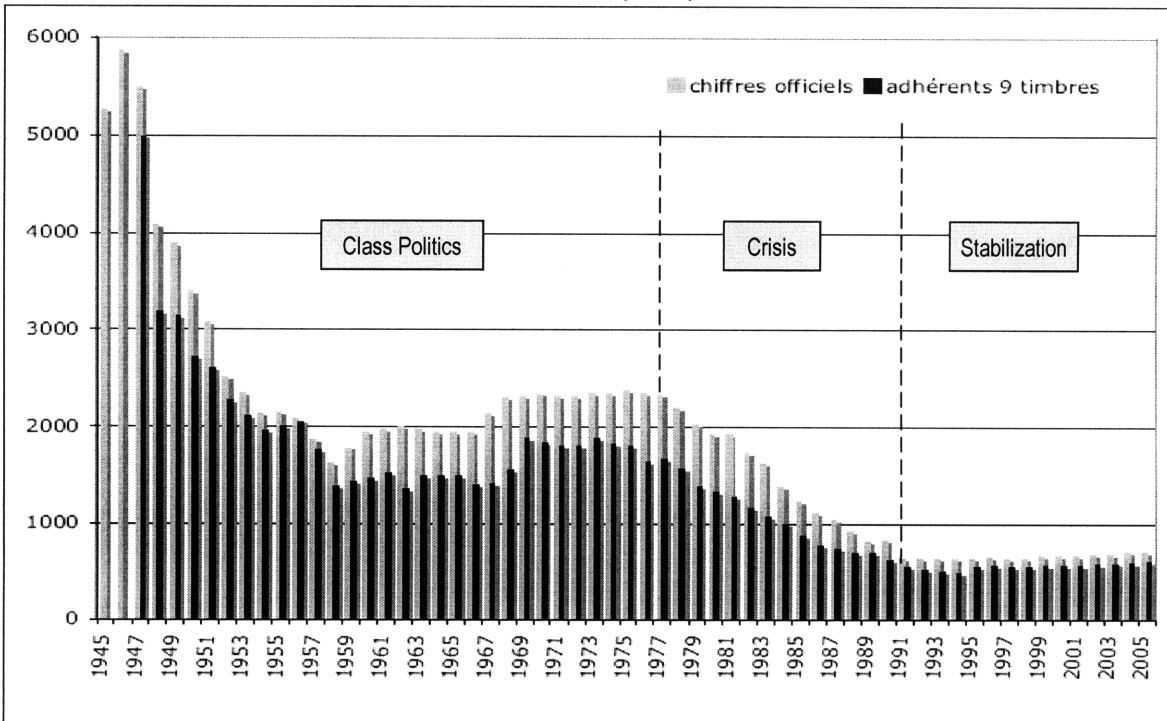

Note: "Chiffres officiels" = Official Numbers; "Adhérents 9 timbres" = Members paying their dues 9 times a year. The discrepancy between the two decreased in the 1990s because the CGT tried to be more transparent to improve its public image.

Source: Andolfatto and Labbé (2007: 59).

Even though the data on trade union membership varies from one source to another, the trend is always the same and three periods stand out (see Figure 6.2). The first spanned from the late 1940s to the late 1970s. During this period, the CGT was relatively stable in spite of small downs (in the late 1950s) and ups (in the wake of May 1968). It was the golden age of class politics. The second period went from the late 1970s to the early 1990s and was characterized by a sharp membership drop. The CGT lost almost one million members in thirteen years. This situation of crisis might have brought about massive changes, but it did not. The leadership of the CGT depicted the “crisis of unionism” (*crise du syndicalisme*)—as commentators and journalists called it—as part of an ideological attack on progressive forces. The word “crisis” had to be avoided and was replaced with “struggle.” Finally, the third period began in the early 1990s and indicated a stabilization and even a slight increase, thereby suggesting that the CGT had found a way to stop the hemorrhage and consolidate its constituency.

The social composition of the CGT changed during these three periods (see Figure 6.3). Dominant industrial federations, such as the metalworkers’ federation, lost their hegemonic position and the CGT became more dependent on the public sector, particularly energy, public services, and postal and communication services (PTT). Because of their demographic weight, workers’ federations of the public sector now hold the key to the balance of power inside the CGT. Another striking feature is the dramatic decline of the textile and apparel workers’ federation during the 1980s, from 64,000 members in 1980 to 7,000 in 1993. Finally, it is worth stressing that the crisis of traditional industrial manufacturing is not enough to account for the decline of the total membership of the CGT. Although the membership of the metal workers’ federation—CGT’s leading

workers' federation—did drop considerably, the CGT lost a substantial amount of members even in sectors where employment was booming. For example, employment in the retail sector went from 1,937,000 workers in 1974 to 3,068,000 in 1993. During this same period, the retail workers' federation of the CGT dropped from 49,000 to 14,000 members. Similarly, employment in the health sector went from 889,000 in 1974 to 1,582,000 in 1993. Meanwhile, the health workers' federation of the CGT dropped from 75,000 to 33,000 members (Andolfatto and Labbé 1997: 269).

Figure 6.3: CGT Membership by Workers' Federation, 1974-1993

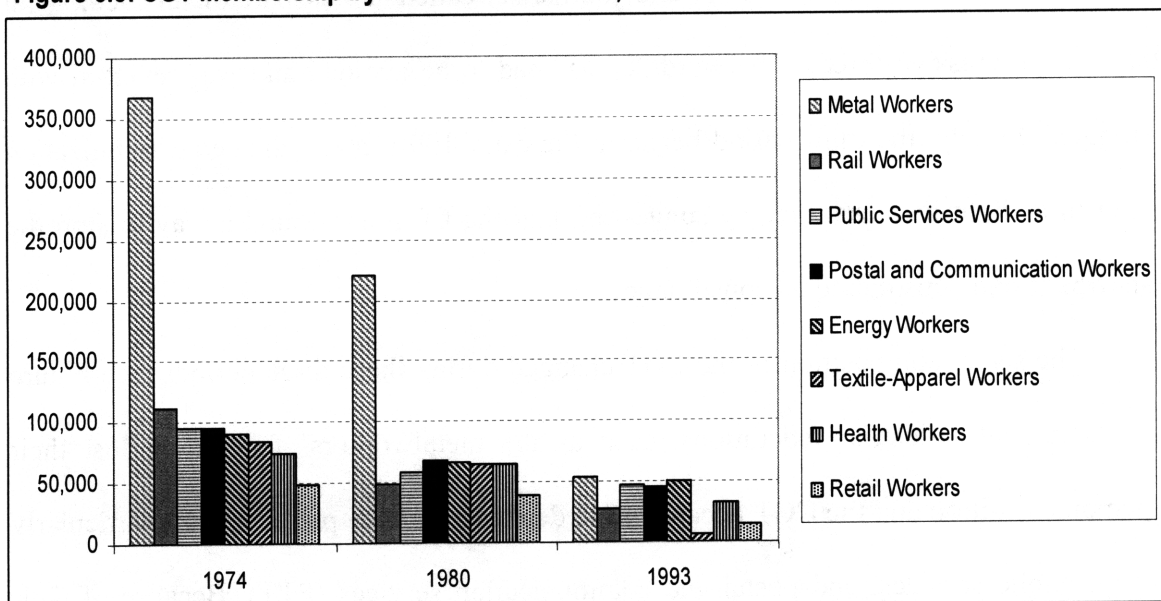

Source: Andolfatto and Labbé (1997: 269).

Although French unions can count on several other sources of funding—particularly public subsidies²⁴³—membership dues represent a substantial share of their total financial resources. For example, in 2001 membership dues generated almost

²⁴³ For a brief survey of these sources of funding, see Chapter 3.

€4,000,000 of revenue for the CGT. In contrast, in 2005 the French Ministry of Labor gave €7,500,000 to the CGT so that the latter could train union delegates, elected officials, and arbitration staff (Anfoldatto and Labbé 2006b: 126).

Membership decline has implications not only for financial resources but also for the trade unions' claim to representativity and, thereby, legitimacy. In this respect, the societal legitimacy crisis that the CGT faced in the 1980s was deeper than for other trade unions. Not only were membership losses bigger in absolute terms, but also the support that the CGT enjoyed among workers fell significantly. As Figure 6.4 shows, the share of the CGT in professional elections in the private sector fell consistently until the early 1990s whereas other trade unions either remained stable or slightly improved their performance.²⁴⁴ Considering this gap between the CGT's electoral performance and that of its competitors, the CGT's lack of drastic measures to correct the situation is even more puzzling.

²⁴⁴ Figure 6.4 also shows that an increasing share of workers elects non-unionized workers to represent them, thereby suggesting that fewer and fewer workers trust trade unions.

Figure 6.4: Work Councils Elections, 1966-2001²⁴⁵

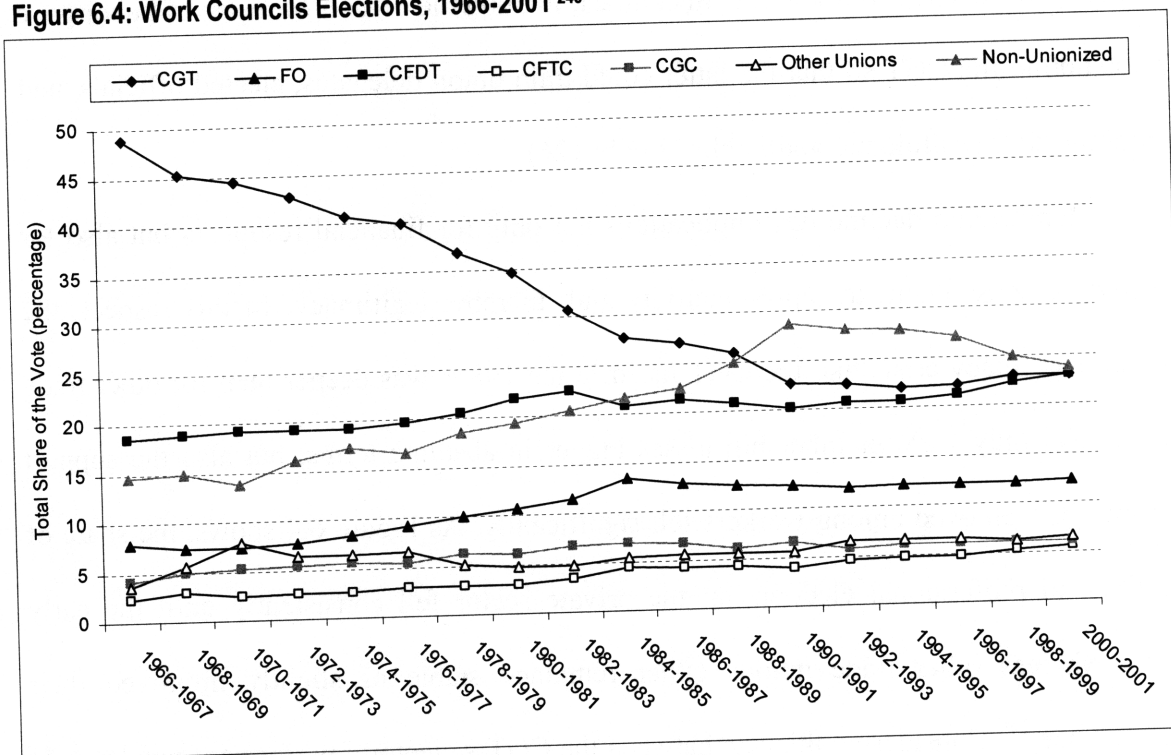

Source: Andolfatto and Matuszewicz (2004: 102).

The situation of the CGT was accentuated by the decline of the PCF. After a peak in 1978, the PCF's membership began to fall steadily. It fell from 520,000 to 133,351 declared members between 1978 and 2002 (Courtois and Lazar 2000: 461, Lavabre and Platone 2003: 47-48). Although it still had more members than most French political parties, its decline undermined its image of a mass party and capacity to pressure its main leftwing competitor, the PS. The decline of the PCF also implied an increasingly poor electoral performance. Since the late 1970s, it has been winning fewer and fewer seats in the National Assembly (see Figure 6.5). Since 2002, it has even obtained fewer votes than

²⁴⁵ Work councils elections take place at varying dates in private firms that have over 50 employees and in a few public firms such as the SNCF, the national state-owned railways company. Work councils are usually divided in three colleges that include different types of workers. Nonetheless, the numbers cited here are cumulative and refer to the total of the three colleges.

its Trotskyite rivals in presidential elections.²⁴⁶ Insofar as the CGT and the PCF had not only a strong, exclusive linkage but also relied on the same social base, the individual decline of the two organizations was closely intertwined.²⁴⁷ However, at the same time the decline of the PCF entailed a loosening up of the linkage between them and, thereby, opened a space for the CGT to engage in a gradual process of change that would lead it to depart from its path.

Figure 6.5: Electoral Performance of the PCF in Legislative Elections, 1945-2007

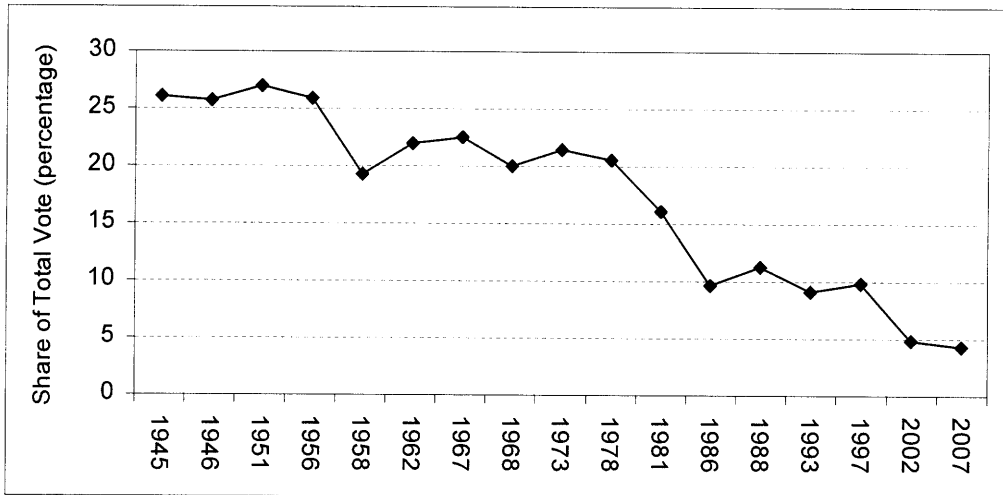

Source: CEVIPOF.

Note: All electoral results refer to the first ballot.

The pressure to—but also possibility for—change got even more acute with the fall of the Berlin Wall and, soon after, the USSR. The pro-soviet World Federation of Trade Unions (WFTU), in which the CGT was heavily invested (the CGT had been a founding member of the WFTU and CGT Secretary General, Henri Krasucki, was vice-president of

²⁴⁶ In the 2002 presidential election, the PCF candidate, Robert Hue, got 3.4 percent of the vote, compared to 5.7 for Arlette Laguiller (Lutte ouvrière/Workers' Struggle [LO]) and 4.2 for Olivier Besancenot (Ligue communiste révolutionnaire/Communist Revolutionary League [LCR]). In the 2007 election, the PCF candidate, Marie-Georges Buffet, got 1.9 percent of the vote whereas Besancenot (LCR) got 4.6.

²⁴⁷ According to Andolfatto and Labbé (1997: 203), the CGT was strong in the regions where the PCF got its best electoral score, and vice-versa.

the WFTU), became isolated. Moreover, the CGT was still being denied membership in the European Trade Union Confederation (ETUC) precisely because it was a member of the WFTU.²⁴⁸ By the early 1990s, globalization was increasingly on everybody's lips but the CGT could not rely on allies outside of France. It had not only to rebuild its social base but also to reach out for new alliances.

4 | THE POLITICS OF ORGANIZATIONAL MAINTENANCE

In the era of class politics the CGT managed to mobilize resources and sustain its hegemony over the French labor movement, but from the 1980s it experienced an organizational failure that fostered internal struggles and eventually led it to depart from the path on which it had been embarked since the late 1940s. However, the fact that the CGT faced pressures to adjust to its environment did not mean that it would mechanically do so. The CGT took a long time to acknowledge it was experiencing a crisis and react to it. Such a lag stems from the CGT's particular politics of organizational maintenance, that is, the internal struggle between defenders of the status quo and advocates of adjustment.

In contrast to the CFDT, which changed through a process of conversion, the CGT changed through a process of *drift* that implied an erosion of its ability to mobilize resources as conservative leaders deliberately refused to close the gap between their organization and its shifting surrounding environment (cf. Streeck and Thelen 2005: 25).

²⁴⁸ Officially, the fact that the CGT was close to the PCF was not the reason why it was denied membership. The Italian CGIL was close to Italian Communist Party but joined the ETUC in 1973, after it had left the WFTU. The official reason was the fact that the CGT was an active member of the WFTU. The ETUC was founded by the International Confederation of Free Trade Unions (ICFTU) and was anti-Soviet. The logic of the Cold War entailed that trade unions could not belong to the two organizations simultaneously.

Once the CGT finally acknowledged it was going through a crisis, it engaged in a process of *layering* (cf. Streeck and Thelen 2005: 23) in which leaders worked around unchangeable elements to reframe the CGT's discourse and invest resources in new alliances with unanticipated constraining effects. This blend of drift and then layering led the CGT to depart from its previous path.

In order to explain why the CGT embarked upon a given path rather than another, this section will discuss three causal mechanisms that structured the CGT's politics of organizational maintenance: bricolage, identity shift, and opening. As I will show, these three mechanisms were conditioned by the CGT's organizational repertoire and linkages.

4.1. Bricolage

In the process of bricolage, actors articulate a narrative of the problem they face which has implications for the solutions they advocate. This narrative constructs the problem to which the organization is confronted and inserts it in a causal chain of events that points toward a given solution rather than another (Hay 2001, Poletta 1998, Stone 1989). Actors respond thus not so much to an objective situation as to its narrative construction, whether or not it is accurate (cf. Bruner 1991, Hay 2001, Patterson and Monroe 1998, Steinmetz 1992).

The CGT's politics of organizational maintenance involved two competing narratives. The first was articulated by the confederal leadership of the CGT and initially denied that the CGT was experiencing organizational failure. The second was formulated by relatively isolated but nonetheless highly ranked individuals and/or leaders of workers'

federations. This narrative was marginalized from the CGT during the 1980s but reemerged in the early 1990s, as the confederal leadership itself picked it up when it finally acknowledged that the CGT was facing a crisis.

The Confederal Narrative

In 1980s, the confederal leadership of the CGT claimed that the CGT not really experiencing organizational failure. Although it acknowledged membership decline, it ruled out the idea of a “crisis of unionism” (*crise du syndicalisme*). According to the confederal leadership, the CGT was losing members essentially because of two factors: the deepening of the economic crisis and an anti-CGT ideological campaign and repression.

The economic crisis brought about mass unemployment and growing flexibility and undermined the social rights and status of workers. This situation entailed an increased competition between workers that made it more difficult for them to realize that they shared class interests opposed to those of capitalists (Magniadas 1987: 135).²⁴⁹ Insofar as traditional industrial manufacturing and large firms were particularly affected, the CGT lost more members than other trade unions. The confederal narrative contended that even though the economic crisis had an adverse impact on trade unions in most advanced industrial economies, the CGT was the most affected labor organization in France because it was the most active opponent of capital; it was the victim of harsh a ideological campaign and targeted repression.²⁵⁰ Thus, the confederal leadership rejected the claim that

²⁴⁹ Although here I refer specifically to the analysis of Jean Magniadas, member of the Executive Commission of the CGT in the 1980s and director of its Center for Economic and Social Studies, this assessment came up in numerous internal bulletins of the CGT in the 1980s.

²⁵⁰ Henri Krasucki, “Rapport du bureau confédéral,” 42nd confederal congress of the CGT, November 24-29, 1985, p. 13. For example, according to Krasucki, in the third trimester of 1984 more than 5,000 militants of

the CGT was going through a crisis or situation of organizational failure: “There is no crisis of our struggle unionism, recent facts demonstrate it with glare; there is on the other hand a CGT that is well grounded in a hard battle without mercy against a powerful and seasoned class adversary that is all the more aggressive as it feels threatened.”²⁵¹ Hence the conclusion that the CGT should talk about the *battle for* rather than the *crisis of unionism*.²⁵²

This picture of the situation favored certain solutions over others. Insofar as the CGT itself was not responsible for its decline, organizational maintenance did not require major strategic and organizational changes. In 1982, the confederal leadership reasserted that the electoral victory of left would create a very favorable context for a membership rise that would compensate the losses of the last few years and ruled out the self-criticism that the former Secretary General of the CGT, Georges Séguy, had articulated in the 1978 confederal congress on grounds that it fed the anti-CGT campaign.²⁵³ Although the confederal narrative pointed out that the CGT needed as many members as possible to pressure its opponents and the state, it neither presented recruitment as a priority nor laid out a specific tactic to attract more workers. It relied instead on the assumption that if militants of the CGT were present on the workplace to fight for workers’ interests, then

the CGT faced sanctions and layoffs, entire local unions were fired, and 300 militants were facing criminal charges.

²⁵¹ Alain Obadia, “La bataille idéologique aujourd’hui,” *Le Peuple* No. 1239, April 9, 1987, p. 11. Such statement is surprising considering that Obadia was close to former CGT Secretary General Georges Séguy. Moreover, in 1994 Obadia resigned from the Confederal Bureau of the CGT in 1994 on grounds that the CGT refused to substantially revise its strategy so as to adjust to the new post-industrial context (Alain Obadia, quoted in Andolfatto 1995: 181-84).

²⁵² Magniadas (1987: 131-32) stated that the expression “crisis of unionism” attacked “the very foundations of unionism by presenting it as archaic, useless, even harmful.” See also Alain Obadia, “La bataille idéologique aujourd’hui,” p. 12.

²⁵³ CGT, “Document d’orientation,” 41st confederal congress of the CGT, June 13-18, 1982, p. 787-88.

workers would support them and join the CGT.²⁵⁴ It did not carry large surveys, as the CFDT did with the GAPS, to find out why exactly were members not renewing their membership card or refusing to join. The confederal leadership was constrained by the Marxist-Leninist inspired organizational repertoire of the CGT that presumed that the trade union was the avant-garde of the working-class and, as such, knew better than workers themselves what had to be done. The solution to membership decline, according to the confederal narrative, was a more militant CGT. This line served the PCF's strategy. After leaving in 1984 the coalition government led by the PS, the PCF began to attack the PS as sell-out to capitalism and needed the CGT to organize protest campaigns to express workers' discontent.

During the 1980s, the evolution of the social composition of the CGT (cf. Figure 6.3) entailed that workers' federations based in the public sector and public services could impose their priorities. Meanwhile, the socialist government discarded its ambitious nationalization program and started privatizing public firms. As a result of these two phenomena, the defense of public sector professional status and benefits became a top claim of the CGT at the expense of private sector workers who nonetheless faced major industrial restructuring and mass layoffs. The CGT began to abandon its offensive stance of the 1960s and 1970s to gradually adopt a purely defensive posture that hampered membership recruitment in sectors where employment was booming and where there was, therefore, a potential for organizational growth.

²⁵⁴ CGT, "Document d'orientation," 42nd confederal congress of the CGT, November 24-29, 1985, p. 459.

The Dissenting Narrative

In contrast to what happened in the CFDT, dissenting actors in the CGT did not produce an “oppositional” or “insurgent” narrative that directly challenged the authority of the confederal leadership. All actors, on both sides of the debate, were active members of the PCF and, thus, shared common premises. The dissenting narrative acknowledged the negative impact of the economic crisis on the CGT and denounced anti-CGT campaigns, but also stressed the responsibility of the CGT in fostering membership decline. This nuance led it to favor different solutions to address organizational failure.

The dissenting narrative was originally developed by CGT Secretary General Georges Séguy in the late 1970s. Although at the time membership loss was minimal, Séguy argued that the CGT had to look in the mirror and recognize that it was a closed organization that suffered from a limited internal democracy and had an ideologically homogeneous leadership that did not reflect the diversity of its membership. According to Séguy, such organizational characteristics pushed workers away from the CGT.²⁵⁵ But this self-criticism did not last. Séguy soon backed down because of the pressure of the PCF (Andolfatto and Labbé 2006a : 330) and in 1980 the confederal leadership asserted that the CGT was doing well even though it was actually losing an increasing number of members and votes in professional elections (Moynot 1982: 64).

In the early 1980s, Jean-Louis Moynot (1982: 65-66), a member of the Executive Commission of the CGT at the time, expanded the dissenting narrative and denounced the subordination of the CGT to the political strategy of the PCF at the expense of real gains

²⁵⁵ Georges Séguy, “La bataille du recrutement est lancée: La CGT partout et pour tous,” *Le Peuple* No. 984, February 25-29, 1976, p. 5-6; Georges Séguy, “Rapport d’ouverture,” 40th confederal congress of the CGT, November 26-December 1, 1978, p. 31-33.

for workers and the CGT. According to Moynot (1982: 74), the inability of the CGT to implement organizational changes stemmed not so much from the domination of the PCF, of which Moynot was a member,²⁵⁶ as from the political culture of high-ranking officials of the CGT and their disconnect from rank-and-file members. Moynot also called the CGT to revise its position toward Europe. He argued that there was no national solution to the economic crisis and, therefore, the CGT had to adopt a constructive position toward European integration: “We cannot say that we consider the European Economic Community as a given and, at the same time, hold a negative assessment of everything that is developing within or around it on grounds that it is dominated by great capital” (Moynot 1982: 162). For Moynot, the solution to the economic crisis and to the CGT’s organizational failure rested on a change of organizational strategy that would avoid mythic conceptions of working-class struggle and focus instead on pragmatic negotiations and propositions to incrementally gain benefits for workers.

After Moynot’s resignation from the Executive Commission in 1982, the dissenting narrative lacked influential advocates.²⁵⁷ Workers’ federations based in the public sector and public services, that now dominated the CGT, primarily supported the confederal leadership and downplayed organizational failure. Nonetheless, the main themes of the dissenting narrative—internal democracy, transparency, real autonomy from the PCF, etc.—reemerged in the late 1980s and early 1990s, but this time there were voiced by the confederal leadership itself and integrated to a new confederal narrative that attempted to

²⁵⁶ Moynot was initially a Christian leftist (*chrétien de gauche*) that subsequently decided to join the PCF.

²⁵⁷ There were several other resignations, including René Buhl, Jacqueline Lambert, and Christiane Gilles (Andolfatto and Labbé 2006a: 330).

revitalize the CGT as the latter reached the lowest membership level and electoral performance of its history.

The New Confederal Narrative

The new confederal narrative emerged in the 1989 confederal congress of the CGT and put forward a more consensual diagnosis of the situation the CGT was facing. First, it acknowledged the magnitude of the CGT's organizational failure and presented membership recruitment as a "vital" issue.²⁵⁸ Second, it underscored both contextual (such as the economic crisis, the transformation of the organization of production, and anti-CGT campaigns) and internal factors (such as the lack of transparency and democracy). Even the autonomy from the PCF, which had been a source of major dissensions inside the CGT, was addressed. Although it claimed its right to intervene in public affairs, the CGT noted that it could not support a political program developed by political parties as it had done in the 1970s with the Common Program.²⁵⁹ Insofar as objective factors were difficult to correct, the CGT had to take measures to introduce organizational changes that would allow it to attract workers anew. It had to become more transparent and democratic so that workers would have access to the relevant information and feel that they had a say in the orientation and decisions of the organization. Thus, the new confederal narrative was primarily concerned with rebuilding the internal and societal legitimacy of the CGT.

²⁵⁸ At the same time, however, the report of the Confederal Bureau of the CGT, delivered at the 43rd confederal congress in 1989, sometimes seemed to reveal a state of denial. It stated that the CGT had been making progress in professional elections for several years in a row when actually its share of the vote in, for example, work councils had been decreasing consistently since the 1960s (see Figure 6.4). Henri Krasucki, "Rapport du Bureau confédéral," 43rd confederal congress of the CGT, May 21, 1989, p. 30.

²⁵⁹ CGT, "Document d'orientation," 44th confederal congress of the CGT, January 26, 1992, p. 478.

The new confederal narrative also introduced the theme of resistance. Although it advocated the renationalization of privatized firms and socialist self-management, it deepened the defensive posture of the previous confederal narrative. For example, having been deeply affected by foreign competition and offshoring since the 1970s, the textile-apparel workers' federation of the CGT tied the defense of employment and resistance to organizational maintenance. Offshoring had to stop to preserve local employment and allow the CGT to mobilize workers anew. Christian Larose, Secretary General of that workers' federation from 1982 to 2003, even called for an anti-offshoring law that would defend employment in the textile-apparel industry.²⁶⁰ The emphasis on negotiation, which had been a central element of the dissenting narrative, remained secondary in this new confederal narrative. The textile-apparel workers' federation stressed the virtues of negotiation and propositions rather than just claims and protest, but in practice its propositions generally took the form of a list of demands that ignored the competitive context in which firms operated.²⁶¹

In spite of all the changes announced (more transparency, more internal democracy, more autonomy from the PCF) in the new confederal narrative, the CGT still believed that membership recruitment and unionization would stem from a focus on the needs, demands, and actions of workers.²⁶² Such a belief derived from the CGT's conception of union membership that was deeply anchored in the Marxist-Leninist tradition from which its

²⁶⁰ I will discuss the content of this law in section 5.2, when I present the CGT's demands that characterize the resistance strategy.

²⁶¹ In this respect, there were different from the plan proposed by the steelworkers' federation of the CGT in the late 1970s to restructure the French steel industry.

²⁶² CGT, "Document d'orientation," 44th confederal congress of the CGT, January 26, 1992, p. 471.

organizational repertoire drew. Like dissenting factions in the CFDT, the CGT celebrated *militants* rather than plain members. As Christian Larose put it:

The issue is not to get members for the sake of members. If you recruit members, it is to carry out a battle, a struggle, not just to get money. The issue is to figure out on what grounds you recruit members. What the CFDT does, with its recruiting agents [*sergents recruteurs*] everywhere, looks a bit military to me. For me, that's not the issue. The issue is to recruit members to organize the resistance.²⁶³

Along the same line, Larose did not believe that the anti-offshoring law that his workers' federation proposed would actually regulate international trade. But he thought that it would give workers something to fight for and, thereby, widen their perspective and boost their motivation to join or support the CGT.²⁶⁴

In spite of its limits and contradictions, the new confederal narrative created the conditions to stop the drift that characterized the CGT in the 1980s. By acknowledging the organizational failure of the CGT and identifying internal causes, it initiated a process of change that would gradually lead the CGT to depart from its path. Although the new Secretary General of the CGT, Louis Viannet, who replaced Krasucki in 1992, was faithful to the PCF, he soon engaged in reforms that opened the CGT and fostered internal contradictions that shaped the CGT's response to globalization.

4.2. Identity Shift

Since the CGT's confederal leadership knew that some aspects of the CGT could not be changed without provoking a strong reaction, either from specific workers' federations and

²⁶³ Interview with author, April 2003.

²⁶⁴ Idem.

high officials or from segments of the rank-and-file, it tried to work around unchangeable elements and gradually develop new dynamics that would avoid a direct confrontation with supporters of the status quo. Identity shift was at the center of this process of layering (cf. Streeck and Thelen 2005: 23). It implied the de-activation of a symbolic boundary of the CGT's collective identity, that is, the decrease "in the salience of the us-them distinction separating two political actors" (Tilly and Tarrow 2007: 215).

As the confederal leadership articulated the new narrative that I described above, it reframed the analytical categories of the CGT and in doing so, slightly redefined the collective identity of the organization in ways that made it more porous to outside influences and that facilitated the construction of new alliances and linkages.

Supporters of the status quo defended the workerist, anticapitalist identity of the CGT and were suspicious of any amendment to the class struggle discourse. According to CGT Secretary general Louis Viannet (1995: 105), although organizational change was necessary and urgent to reconquer the lost ground, it had to be accomplished in a manner that would not upset those members who were still very attached to the ideas of class struggle and reluctant to any form of change. However, workerism and class struggle discourse had been losing their capacity to resonate among French workers, all the more since the collapse of the USSR. The process of reframing, or symbolic reconstruction, aimed thus at reassuring supporters of the status quo inside the CGT while making the CGT more engaging for non-unionized workers. The confederal leadership did not completely abandon the logic of class struggle and anticapitalism. It still formulated claims in terms of an opposition between labor and capital, but the category of "exploited worker"

no longer referred exclusively to blue-collar workers, the typical symbol of industrial class unionism. As a report of the confederal bureau of the CGT ironically put it:

The contradiction between exploiters and exploited is still the deep reality of French society today and the only effective way to allow wage earners to have a voice remains the collective defense of their material and moral interests. But it's also true that the circle of the exploited has widened and diversified considerably. The business community [*patronat*] would be pleased if the CGT would suffer from blindness to the extent of reducing its vision and conception of class unionism to a unionism of only blue-collar workers [*ouvriers*]. A CGT all dressed in blue... that would be so much better!²⁶⁵

The confederal leadership progressively replaced the “working class” with “wage earners” (*salariés*) (Hetzl et al 1998, Salem 1993) so as to avoid symbolic markers that would exclude potential members from other segments of the labor market, particularly employees in services. More generally, “capitalism,” while not disappearing, increasingly coexisted with references to the “market” and the “rule of money” (*l'argent-roi*). Like the PCF during the 1990s, the CGT increasingly framed its claims in terms of antiliberalism rather anticapitalism. The *regulation* of capitalism replaced its *overthrowing* and emblematic demands of the era of class politics, such as the nationalization of leading private firms, were abandoned in favor of new concepts like global public goods.²⁶⁶ In the

²⁶⁵ Louis Viannet, “Rapport du bureau confédéral,” 44th confederal congress of the CGT, January 26, 1992, p. 11.

²⁶⁶ Interview with Joël Décaillon, formerly in charge of European affairs at the CGT and since 2004 representative of all French trade unions at the European Trade Union Confederation (ETUC), April 2003. Décaillon gave the example of water and drugs and explained that we needed to regulate the access to such public goods instead of nationalizing the firms producing them. Although he is not representative of the CGT as a whole, Jean-Christophe Le Duigou (2005: 248), former Secretary General of CGT's finance workers' federation and one of the main authors behind the CGT's demand for a “professional social security,” recently stated: “We know the market. We try to shape it, to control it, to transform it. We're not in favor of its abolition as it happened in the Soviet experience. . . . We want . . . to conquer a ‘market economy’ with its rules, institutions, guarantees, but also public tools and non-market dimensions that we need to develop, such as research, education, health, culture.”

late 1990s, CGT Secretary General Bernard Thibault defined the CGT's identity in the following way:

The first dimension of the CGT's deep identity is thus that of a union that defies the business' arbitrary behavior and the reason of state, that opposes a fierce and educated resistance to all the iron laws that generations of liberal prophets have depicted as natural and to which we should yield. . . . It is all the resistances to exploitation, oppression, discrimination, injustice, scorn, and exclusion, that constitute our identity. . . . Yes, the image of the CGT is that it is a contentious trade union! It is the heart of our identity. . . . The second dimension of the identity of the CGT, inseparable from the first one, is our involvement in the construction . . . of robust and consistent alternatives to liberalism: It is obviously the meaning of our commitment to the defense of the values of public services, questioned and attacked by supporters of liberalism.²⁶⁷

At the same time, however, the CGT consistently reasserted that the fundamental, structuring conflict of society was the antagonism between labor and capital. It did not become a social democratic labor organization. The market and entrepreneurs were not seen as potentially beneficial to society. They had no legitimacy in the eyes of the CGT. They were barely tolerated, if not rejected. The discursive shift remained thus within the realm of the CGT's organizational repertoire, structured around anticapitalism and statism. It was a real but nonetheless limited departure from the CGT's historical discourse and collective identity.

Such a reframing implied taking into account and giving room to interests and perspectives that went beyond class. Although the CGT did not call for social partnership as the CFDT, it did try to define its role as an actor in civil society. In doing so, it slightly recast the collective identity of the CGT away from its traditional class anchoring and toward a more societal stance (cf. Hyman 2001) (see Figure 6.6). For example, a report of

²⁶⁷ Bernard Thibault, "Rapport d'ouverture," 46th confederal congress of the CGT, January 31-February 5, 1999, p. 22.

the Confederal Bureau of the CGT stated: “The entire French labor movement stands in front a huge responsibility for the future of social guarantees in our country, . . . what is at stake is our quality of life and even our degree of civilization.”²⁶⁸ This shift, with its boundary de-activation, had an impact on interorganizational relations since it made it possible to consider new alliances with former opponents, moderate trade unions, and civic associations or NGOs at the domestic and international level.

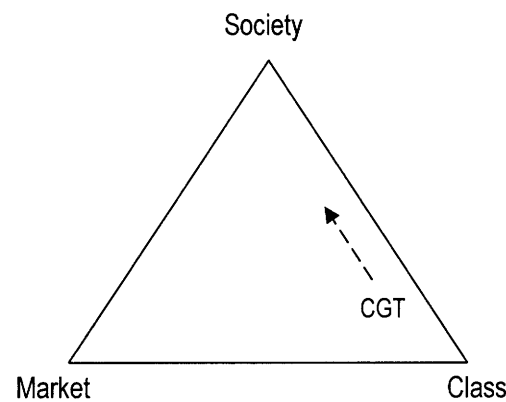

Figure 6.6: The Identity Shift of the CGT

4.3. Opening

The opening of the organizational opportunity structure of the CGT implied (1) an increased tolerance of the executive leadership of the organization vis-à-vis dissenting perspectives, (2) an increased capacity to pressure the confederal leadership and, thereby,

²⁶⁸ Alain Obadia, “Les problèmes du syndicalisme aujourd’hui,” *Le Peuple* No. 1355, July 2, 1992, p. 15. This quote above is similar to Pierre Bourdieu’s speech at the Gare de Lyon during the 1995 strikes: “I am here to express our support for those who have been fighting for three weeks against the destruction of a *civilization*, associated with the existence of the public service, the Republican equality of rights, rights to education, health, culture, research, arts, and, above all, work” (Bourdieu 1998: 30).

to influence the decision-making process, and (3) a loosening of the linkages between the CGT and the communist eco-system.

The increased tolerance of the leadership was related to the identity shift that I described above insofar as it opened a space for a relative diversity of stances inside the CGT: ideas of class struggle could coexist with a defense of the state in antiliberal terms and a reformist perspective that focused on the regulation of the market. New formulations and ideas stood next to old ones. Their coexistence allowed the confederal leadership to engage the CGT in a process of change without provoking a major countermobilization by defenders of the status quo.

The increased capacity to pressure the confederal leadership of the CGT stemmed from a commitment to greater transparency. This commitment was made in 1989 with the hope that it would improve the image of the CGT among workers and facilitate the retention and recruitment of members. This new “policy” entailed regularly making public the actual membership and financial situation of the organization.²⁶⁹ The availability of relatively accurate data on the CGT was a crucial resource for supporters of organizational change and weakened defenders of the status quo who had been claiming during the 1980s that the CGT was doing as well as it could given the circumstances.

The loosening of linkages between the CGT and the communist eco-system (i.e., the PCF but also originally pro-Soviet international organizations like the World Federation of Trade Unions, WFTU) began in the mid-1990s. The electoral and organizational decline of the PCF and the collapse of the USSR as well as the replacement of the Secretary General of the CGT, Henri Krasucki, in 1992 provided the conditions for

²⁶⁹ Pierre Koehler, “Rapport financier,” 43rd confederal congress of the CGT, May 21, 1989, p. 249.

such change. As Joel Décaillon, formerly in charge of European affairs at the CGT and since 2004 representative of all French trade unions at the European Trade Union Confederation (ETUC), explains:

While Henri Krasucki was Secretary General of the CGT, it was difficult to make progress on Europe. He was responsible for European affairs at, and vice-president of, the WFTU. Because of his history and trajectory, he did not have a clear vision of European issues. He had a very pro-Soviet vision. The difficulty was thus to engage in an effort while knowing that the Secretary General was in a position to appreciate our work and the change it required.²⁷⁰

When Krasucki was replaced with Louis Viannet in 1992, the CGT began move away from the WFTU. Although Viannet was faithful to the PCF, the growing isolation that followed the collapse of the USSR and the dramatic situation of the CGT's membership led him to invest in the reconstruction of the CGT's alliances. Thus, the CGT criticized the inability of the WFTU to adjust to the post-Soviet context and renew international trade unionism and left it in 1995.

Simultaneously, as polls consistently indicated that the political alignment of the CGT with the PCF undermined its image among workers, the confederal leadership took symbolic steps. First, in 1993 it stopped calling its members to vote for the PCF in national elections. Then, in 1996 Viannet resigned from the Political Bureau of the PCF (but not from its National Committee, formerly known as the Central Committee) and in 1999, the CGT refused to officially support a national protest day organized by the PCF. Finally, in 2001 the CGT announced that it would henceforth forbid its confederal officials from taking leading positions in the PCF and in 2003, Bernard Thibault, Secretary General of

²⁷⁰ Interview with author, April 2003.

the CGT since 1999, received a standing ovation at the congress not of the PCF but of the PS (Andolfatto and Labbé 2006a: 332-35).²⁷¹

As a result of all these changes, the CGT was able to join the European Trade Union Confederation (ETUC) in 1999, after having applied four times since the ETUC's creation in 1973.²⁷² Although it had harshly criticized it during the 1970s and 1980s, the CGT adopted a more conciliatory tone and stated that the ETUC had become an open and plural organization.²⁷³ This reconfiguration of interorganizational relations consolidated the opening of the CGT's organizational opportunity structure. Defenders of the status quo had favored an exclusive strong linkage with the PCF and its eco-system. The institutionalization of the new configuration through membership in the ETUC allowed supporters of organizational change to weaken their opponents at the confederal level.²⁷⁴ The linkage between the CGT and the PCF did not disappear. It continued to shape the CGT,²⁷⁵ but it no longer was as strong and determinant as it had been during the era of class politics.

²⁷¹ However, in order to become Secretary General of the CGT Thibault, who had been a member of the PCF since 1987, had first to enter the National Committee of the PCF in 1997 (Andolfatto and Labbé 2006a: 333).

²⁷² Membership in the ETUC requires the sponsorship of trade unions from the same country. The CFDT and Force ouvrière (FO), both members of the ETUC since the 1970s, had previously blocked the CGT's application.

²⁷³ Bernard Thibault, "Rapport d'ouverture," 46th confederal congress of the CGT, January 31-February 5, 1999, p. 23.

²⁷⁴ However, dissenters organized at the level of workers' federations. As a result, the collecting of membership dues, so far controlled by workers' federation, became a crucial issue in internal debates.

²⁷⁵ For example, the internal debates of the CGT are often a mirror of those of the PCF.

5 | RESPONSES TO GLOBALIZATION AFTER CLASS POLITICS: THE RESISTANCE STRATEGY

The way in which the CGT gradually responded to organizational failure and tried to insure its maintenance led it to deviate from the path it had taken during the era of class politics. It no longer mobilized resources through appeals to blue-collar working-class identities, calls for a socialist program advocating nationalizations, and strong linkages with the PCF and its eco-system. Instead, it increasingly attempted to recruit members among employees and white-collar workers in services, relied on a vague antiliberal rhetoric that created a symbolic space for a diversity of perspectives inside the CGT and facilitated alliance-building with actors that had not been historically associated with the PCF, and engaged in European politics through its membership in the European Trade Union Confederation (ETUC).

While during the era of class politics the CGT responded to globalization with an offensive radical strategy, after class politics its response to globalization became essentially defensive insofar as it pooled its resources to fight off what it perceived as an external threat.²⁷⁶ Today the CGT no longer calls for a transformation of the socio-economic structures of French society; it aims instead at preserving the social benefits and employment security of most of its members.²⁷⁷ Whereas in the 1970s the CGT's

²⁷⁶ This conceptualization of a defensive strategy draws on Tilly (1978: 73).

²⁷⁷ However, CGT members in the private service sector (distribution and retail) do not enjoy the social benefits and employment security of those in public services and semi-public firms.

opposition to globalization rested upon a class cleavage, today it seems to be resting increasingly upon an insider-outsider cleavage.²⁷⁸

Whether or not it stemmed from the strategic and organizational shift of the CGT, the fact that membership decline stopped in the mid and late 1990s lowered the incentives and pressure to change. Similarly, the opening of the organizational opportunity structure made it difficult for defenders of the status quo to roll back the change accomplished so as to return to the previous orientation of the CGT. Henceforth, the CGT would make minor adjustments at the margins without substantially departing from its new path.

Although the organizational failure that the CGT experienced was not directly related to globalization, the politics of organizational maintenance brought about a series of strategic and organizational changes that affected the general orientation of the CGT and, thereby, its position toward globalization. In what follows, I present the CGT's current interpretation of the international economy, the demands it has put forward to address what it sees as the most pressing issues, and the type of alliances it has tried to build. Although the strategy of the CGT has evolved, it remains deeply shaped by the organizational repertoire and linkages.

²⁷⁸ The insider-outsider cleavage opposes workers with protected, stable jobs that provide social benefits (insiders) to workers that either are unemployed or have precarious and badly paid jobs with few or no social benefits (outsiders). Outsiders are overwhelmingly youths, women, and immigrants. It should be noted that the conceptualization of this cleavage often rests upon the questionable assumption that outsiders pay the cost of the insiders' position. In other words, it assumes a zero-sum relation between insiders and outsiders.

5.1. Interpreting the International Economy

The demise of class politics did not lead the CGT to substantially revise its understanding of the international economy. In contrast to the CFDT, it perceives globalization as being a fundamentally negative phenomenon. Even though it no longer uses an explicitly Marxist language marked by references to “productive forces” or “imperialism,” its interpretation remains greatly determined by the anticapitalism that permeates its organizational repertoire. Similarly, albeit it no longer refers to theories developed by the PCF, as in the era of class politics, its interpretation of the international economy parallels in many respects that of the PCF. The linkage between the two organizations has been weakened but not replaced.

For the CGT, globalization is war. It is an economic war for market shares and a financial war to attract foreign investment. This war implies a race to the bottom in terms of wages, working conditions, environmental standards, public spending, social protections, and cultural production, insofar as it leads countries to compete with one another on the basis of their national system of regulation.²⁷⁹ In such context, the existence of social rights becomes a liability for developed countries.

The CGT, particularly through its textile-apparel workers’ federation, also pinpoints offshoring as the major source of unemployment. Christian Larose, former Secretary General of this workers’ federation, claims that offshoring is a mafia-like

²⁷⁹ Jean-Christophe Le Duigou, “Un mouvement social offensif,” *Le Peuple* No. 1484, September 9, 1998, p. 47. Along the same kind of metaphors, CGT Secretary General Louis Viannet compared world speculation to “a real AIDS epidemic for the economy” (Louis Viannet, “Rapport d’ouverture,” 45th confederal congress of the CGT, December 3-5, 1995, p. 14).

operation that steals jobs from workers in advanced industrial economies.²⁸⁰ Some CGT officials hold a more nuanced position. For example, the former Secretary General of the finance workers' federation of the CGT, Jean-Christophe Le Duigou, has been arguing for over a decade that globalization was not a zero-sum game and that offshoring had a minor impact on employment. But this assessment did not prevent him from describing globalization as a state of war.²⁸¹ Furthermore, regardless of their interpretation of offshoring's impact on French employment, all CGT officials agree on the fact that it has *not* fostered the industrialization and wellbeing of developing countries. There is thus room for identifying universal class interests in the Marxist tradition:

Workers, wherever they are, share common interests because they are the 'losers' of this increased competition: In France, because they lose their job. In other countries, because they are overexploited; because generally social and environmental norms are not respected; because firms that offshore do not contribute to a harmonious development in "host countries."²⁸²

More generally, the CGT believes that globalization entails a deepening of inequalities within and between countries and that the new international division of labor leads high-skill labor to be concentrated in the north and low-skill labor to be concentrated in the south.

According to the CGT, there's a contradiction between, on the one hand, the national territoriality of trade unions' influence and achievements and, on the other, the increasing supranationalization of the decision-making process. Although they still have a

²⁸⁰ Interview with author, April 2003. This characterization was also part of the justification of an anti-offshoring law (cf. Textile-apparel workers' federation of the CGT, "Une loi anti-délocalisation dans le textile-habillement-cuir: parcours et propositions," not dated).

²⁸¹ Jean-Christophe Le Duigou, "Délocalisations, développement, solidarité," *Le Peuple* No. 1384, February 1994, p. 21-24. See also Le Guigou (2005).

²⁸² Nasser Mansouri-Guilani, "Délocalisation, externalisation, sous-traitance: Reconquérir l'emploi," *Le Peuple* No. 1575, April 30, 2003, p. 16.

national anchoring, multinational corporations (MNCs) are emblematic of this trend. Decisions with major consequences for the future of employment and production in France are being made abroad without the French having a say. As the decision-making process moves beyond the national territory, it becomes more difficult to influence it:

The primary modification entailed by globalization is the displacement of arbitration places and thus of resource distribution. . . . Trade unions are particularly affected by this process because they were constituted in a national frame. . . . Today many elements that trade unions had helped building, such as sector-wide collective agreements, pension systems, social protections, family allowances, public services, etc., and that had fostered a relative social cohesion, are being undermined by the shift to internationalization.²⁸³

Therefore, the process of globalization not only fosters inequality but also challenges the historical purpose of trade unions.

Who's to blame for globalization? In the era of class politics, the CGT blamed the dynamics of capitalism (the development of productive forces, the profit rate, etc.) and MNCs. The persisting influence of the CGT's organizational repertoire is obvious in today's blame attribution. In spite of the reframing that I described in section 4.2.a, the usual suspects are almost the same: capital and its allied governments, MNCs, and international institutions.

According to the CGT, corporations are essentially driven by an endless quest for profit. Competition and labor cost are just an excuse to reach huge profit margins. For example, the metalworkers' federation of the CGT pointed out that labor cost is only a very small share of the cost of a VCR or a car. Therefore, access to lower wages does not entail cheaper products: "A Clio [Renault car] produced in Slovenia [where wages are

²⁸³ Joël Décaillon, "Les enjeux syndicaux en Europe et dans le monde," *Le Peuple* No. 1536, February 7, 2001, p. 6-7.

lower than in France] is sold at the same price as a Clio produced at the Renault factory of Flins, in France. This proves that behind competitiveness lies the profit margin at the workers' expense."²⁸⁴ Similarly, Christian Larose, former Secretary General of the textile-apparel workers' federation of the CGT, accuses big retailers in the textile-apparel industry, such as Decathlon and Carrefour, of digging France's grave by relying on imports from China, Morocco, Rumania, and Bulgaria.²⁸⁵

The CGT also blames international institutions, particularly the World Trade Organization (WTO). The latter provides a surplus of influence to powerful states (i.e., the United States) and private interests (i.e., MNCs) and institutionalizes free trade. However, in contrast to the era of class politics, during which the CGT hoped that alternative, socialist international institutions would replace existing ones, it now believes that the WTO "can be of benefit to developing countries in relation to the previous system: by setting all member states on an equal footing, it gives, for the very first time in the history of trade relations, the possibility for 'small countries' to challenge the 'big countries.' And small countries have already seized this opportunity."²⁸⁶ Likewise, in 2003 the CGT held a negative assessment of the failure of trade talks at the WTO meeting: "We cannot be glad about the failure of the WTO meeting in Cancun because the world needs regulations, rules

²⁸⁴ Daniel Sanchez, "Métallurgie: Agir pour son salaire c'est défendre son emploi," *Le Peuple* No. 1386, March 31, 1994, p. 14.

²⁸⁵ Interview with author, April 2003.

²⁸⁶ Bernard Thibault, "Leading the battle for regulation against economic war," in CGT, *3è conférence de l'OMC: Réflexions et propositions de la CGT* (Paris: CGT, 1999): 31. Three-language brochure, including English; the quote is thus the official translation.

for economic exchanges and trade, that guarantee a fairer distribution of wealth and foster employment as well as the eradication of poverty in the world.”²⁸⁷

5.2. Demands

While in the era of class politics the CGT aspired to a transition to socialism through the nationalization of the means of production and thought that trade with socialist countries would solve the problems associated with the capitalist international trade regime, in the late 1980s and early 1990s its demands became essentially defensive. Today, though it no longer advocates nationalizations, it still believes that solving the problems generated by changes in the international economy requires strong state intervention. The statism of its organizational repertoire continues to dominate the formulation of its demands.

First of all, the CGT considers that globalization is not inevitable and that the claim according to which states and international institutions cannot do anything against global markets is just a way to legitimate social involution and exclusion: “We need to break the neck of this vertiginous ideological swindle that opens the way for all rackets, rip offs, against wage-earners and populations world wide.”²⁸⁸ In order to maintain its power, the state needs to directly control some leading firms. The CGT no longer calls for nationalizations but does strongly oppose the privatization of firms that were nationalized after WWII or in the early 1980s, after François Mitterand was elected president. Through its nationalized sector, the state is able to control a share of the domestic market and

²⁸⁷ CGT, “Après l’échec de la conférence de Cancun,” *Le Peuple* No. 1583, October 15, 2003, p. 37.

²⁸⁸ Louis Viannet, “Rapport d’ouverture,” 45th confederal congress of the CGT, December 3-5, 1995, p. 15.

promote the development of the whole country.²⁸⁹ Vice versa, privatization entails a loss of national sovereignty. Already in the late 1980s, when the privatization of Renault, France's leading automobile company, was debated, the CGT argued that Renault belonged

to the Nation, and to the Nation only. The idea of belonging to the Nation implies . . . two different but complementary aspects. On the one hand, it's not only about developing the Régie [i.e., Renault] but also, through it, about contributing to the growth of other firms and, thereby, of the whole French economy. In other words, making the Nation richer. On the other hand, simultaneously, it's about improving the condition of workers."²⁹⁰

The CGT officially condemns both free trade and protectionism. As a partial solution to unemployment, it demands higher wages on grounds that such increase will lead to a higher purchasing power for workers and, thereby, to a stronger domestic demand that will in turn, allegedly, create jobs.²⁹¹ However, such measure will be effective only if French consumers turn to *French* rather than *imported* goods. To foster such choice among consumers, the CGT does not bet on the higher quality, distinctive appeal, or competitiveness of French products, but on quotas that will reserve a share of the domestic market to "Made in France" products.

In 1993, the textile-apparel workers' federation of the CGT put forward the project of an anti-offshoring law that would play exactly this role. The law aimed at maintaining two thirds of production in France, stopping public funding for firms that offshore their production, forcing within five years the repatriation of a third of offshored French

²⁸⁹ CGT, "Document d'orientation," 44th confederal congress of the CGT, January 26, 1992, p. 516.

²⁹⁰ CGT, "Renault appartient à la Nation," *Le Peuple* No. 1255, January 14, 1988, p. 41.

²⁹¹ Daniel Sanchez, "Métallurgie: Agir pour son salaire c'est défendre son emploi," *Le Peuple* No. 1386, March 31, 1994, p. 14-15; Christian Larose, "Pour l'emploi et contre la délocalisation," *Le Peuple* No. 1395, October 1994, p. 8-11. Supporters of free trade would reply that another way to increase the purchasing power of consumers is to liberalize trade and lower barriers so that more, cheaper foreign products can enter the domestic market.

production, implementing quotas in the retail sector to put limits on the share of products made abroad that retailer can sell, expanding the rights of work councils so that workers have their say on the way firms use public funds, and preserving the label “Made in France.”²⁹² Some aspects of this project, particularly the safeguard of the “Made in France” label, even got the support of a segment of French entrepreneurs in the textile-apparel industry. Nonetheless, in spite of all the efforts of the textile-apparel workers’ federation the project was discarded by political leaders.²⁹³

The CGT also calls for new forms of state intervention to foster domestic investments in industrial development:

We need to go beyond defensive measures and act before it’s too late, before plants close down. . . . We favor the creation of a public financial pole . . . that will fund projects aiming at the development of industrial activities and quality services with a territorial anchoring. . . . Banks need to take responsibility for the funding of these projects. Technical mechanisms can be conceived so as to create incentives for banks to give credit for facilitating productive rather than financial investments.²⁹⁴

This perspective differs from the CFDT’s call for a “strategist state” that will build comparative advantages (skilled labor force, R&D clusters, etc.) to attract foreign direct investment and compete in the world economy. Here the goal is not to attract capital through comparative advantages but essentially to tie French capital to the French territory

²⁹² Textile-apparel workers’ federation of the CGT, “Une loi anti-délocalisation dans le textile-habillement-cuir: parcours et propositions,” not dated, p. 5.

²⁹³ Interview with Christian Larose, former Secretary General of the textile-apparel workers’ federation of the CGT, April 2003. Larose complained about the confederal leadership’s lack of support for his fight. The law was presented at the National Assembly by the PCF in 1994, but there were no developments. The PCF completely abandoned it once it joined the Jospin government in 1997. In July 1997, CGT Secretary General Louis Viannet sent a public letter to Prime Minister Jospin asking that the anti-offshoring law be considered but nothing happened. Although the struggle against offshoring was not a priority of the confederal leadership in the 1980s, now that offshoring is expanding to several sectors beyond traditional, labor-intensive industries, it has become a more important issue in the CGT’s agenda.

²⁹⁴ Nasser Mansouri-Guilani, “Délocalisation, externalisation, sous-traitance: Reconquérir l’emploi,” *Le Peuple* No. 1575, April 30, 2003, p. 18.

and channel it toward publicly chosen targets. The CGT does not talk about “national champions” but seems confident that the state can still supervise the industrial and economic development of France. In spite of the reframing of its discourse, the CGT still sees trade and the market as chaotic, unjust, and violent, and the state as a source of order and fairness. Without state intervention, globalization, as capitalism, is necessarily brutal.²⁹⁵

In contrast to the CFDT, which sees European integration as a source of protection and as a resource to engage in the world economy, the CGT perceives it as the Trojan horse of globalization and remains very reluctant to engage in European affairs. Notwithstanding its membership in the ETUC and its gradual support for common industrial and educational policies, its stance is primarily defensive and protest-driven (Mitchell 2006). Most of its positions toward Europe generally boil down to a defense of national prerogatives. In international trade negotiations, it consistently denounces instances of American protectionism (agriculture, steel, etc.) on grounds that they have a disastrous effect on exporting countries,²⁹⁶ but simultaneously justifies the European Common Agricultural Policy (CAP)—that overwhelmingly benefits France and is criticized by all developing and developed countries exporting agricultural products—in the name of national agricultural and alimentary independence.²⁹⁷

²⁹⁵ Christian Larose, “Concurrence mondiale et intervention syndicale,” *Le Peuple* No. 1532, October 4, 2000, p. 13.

²⁹⁶ CGT, “Face au protectionnisme américain, L’Europe doit refonder sa politique de coopération internationale,” *Le Peuple* No. 1560, June 5, 2002, p. 40.

²⁹⁷ See, for example: CGT, “GATT: Face aux abandons européens, défendre l’agriculture française,” *Le Peuple* No. 1362, December 17, 1992, p. 39. There are, however, some divergent perspectives inside the CGT but they remain marginal. For example, the former Secretary General of the finance workers’ federation stated: “Quotas and tariffs, even though they are temporarily necessary, are not solutions in and of

With respect to north-south relations, the CGT demands an increase of the price of raw materials, a real scientific and technological cooperation that would entail transfers not conditioned by subordination, an increase of public aid to development, the cancellation of the debt of developing countries, the enforcement of labor rights worldwide to foster employment and growth, the implementation of the Tobin Tax, and co-development in favor of full employment worldwide.

Although the cancellation of the debt has been given more attention since the late 1990s as the CGT tried to build linkages with NGOs (Bérout 2005), most of these demands stay at a high level of abstraction. The CGT never lays out a detailed list of concrete demands with a clear road map. For example, it has referred to co-development since the 1970s but never produced specific proposals beyond invocations of the virtues of cooperation and solidarity. Regarding the enforcement of social and environmental norms, it is skeptical about the effect of codes of conduct but believes nonetheless that corporate social responsibility can foster economic democracy if there is a hierarchy of norms that serves workers instead of treating all stakeholders as equal partners.²⁹⁸ One of its few concrete proposals in this area is to grant the status of WTO observer to the International Labor Organization (ILO) and create an ILO/WTO working group to assess the social impact of international trade as well as find solutions.²⁹⁹

themselves. . . . Any persistent restriction of imports would affect French exports” (Jean-Christophe Le Duigou, “Délocalisations, développement, solidarité,” *Le Peuple* No. 1384, February 1994, p. 23).

²⁹⁸ Joël Décaillon and Alphonse Véronèse, “Quelles stratégies de développement durable?,” *Le Peuple* No. 1562, July 10, 2002, p. 31.

²⁹⁹ CGT, “3^{ème} conférence ministérielle de l’Organisation mondiale du commerce: Réflexions et propositions de la CGT,” *Le Peuple* No. 1512, October 27, 1999, p. 38-40.

Finally, like almost everyone today,³⁰⁰ the CGT demands a reform of the International Monetary Fund (IMF), the World Bank, and the WTO, so as to make them more democratic: “Workers and populations must be involved in the definition of the strategies of international institutions. This is why their respective organizations should have the possibility of taking part in the work of the WTO.”³⁰¹ The CGT also claims that the WTO should fund representatives of the least developed countries so that they can play a full part in the process of trade negotiations. All French trade unions agree with this demand.

5.3. Alliances and Tactics

Since the mid-1990s, the CGT no longer relies on a strong, exclusive party-union linkage to pursue its goals and demands. Although this linkage still exists, the CGT has adopted two contradictory tactics to increase its leverage and respond to globalization. On the one hand, it has tried to gain an institutional legitimacy and access new resources through the construction of a new formal linkage with the European Trade Union Confederation (ETUC). On the other hand, it has been increasingly investing resources in alliance-building with emerging protest movements such as the antiglobalization movement. These two tactics involve different types of collective action (lobby vs. protest) and, more importantly, suppose different stances toward globalization. Indeed, the ETUC is close to

³⁰⁰ For example, in the debate to choose a new director of the IMF in 2007, all actors, including Europeans and Americans, officially agree that the IMF should be reformed to reflect the concerns and growing economic weight of emerging countries.

³⁰¹ CGT, “Conclusions and proposals of the CGT concerning the 3rd ministerial conference of the WTO,” in CGT, *3^e conférence de l’OMC: Réflexions et propositions de la CGT* (Paris : CGT, 1999): 38. Three-language brochure, including English; the quote is thus the official translation.

the adaptation strategy adopted by the CFDT whereas the antiglobalization movement is very critical of the ETUC's orientation and favors a resistance strategy.

The CGT began investing in alliance-building with the antiglobalization movement in the late 1990s. As I explained in Chapter 4, it directly participated in the foundation of ATTAC through two of its workers' federations. On June 30, 1998, a CGT team led by CGT Secretary General Bernard Thibault met with ATTAC to try to determine concrete points of convergence between the two organizations. In the opening statement of the 46th confederal congress of the CGT in 1999, Thibault stated that the CGT shared ATTAC's philosophy and aspiration to build a new citizenship.³⁰² The CGT's investment went beyond ATTAC. It sent a delegation to the 1999 anti-WTO protests in Seattle and made contacts with representatives of the AFL-CIO, the leading American labor organization.³⁰³ Similarly, it attended the World Social Forum (WSF) in Porto Alegre, Brazil, and signed the call for mobilization adopted by the WSF's assembly of social movements. In 2003, it even participated in the organizational board of the European Social Forum of Paris/Saint-Denis and, as such, made a financial contribution (Bérout 2005: 300). The CGT gradually built informal linkages with several key organizations of the antiglobalization movement. Although these linkages remain weak, they represent a symbolic departure from the CGT's

³⁰² Bernard Thibault, "Rapport d'ouverture," 46th confederal congress of the CGT, January 31-February 5, 1999, p. 18.

³⁰³ This encounter had symbolic dimensions because the AFL-CIO had always refused to meet with the CGT on grounds that it was a communist organization. The CGT subsequently published a statement from AFL-CIO President, John Sweeny, something that would have been unimaginable when the CGT was tied to the communist eco-system (cf. John Sweeny, *Le Peuple* No. 1532, October 4, 2000, p. 11). When I asked some members of the CGT who had traveled to Seattle how they felt about this encounter, they seemed satisfied but also irritated by the AFL-CIO's lack of understanding of French politics. One interviewee explained, without realizing the extent to which his comment would not make sense to most Americans: "They had refused to meet with us in the past because they thought we were a communist organization. Can you believe that?! Me, a communist!? When I've been a Trotskyite all my life!" (Interview with author, May 2003).

previous practices, all the more considering that historical political opponents of the PCF like Trotskyites play a central role in the antiglobalization movement.

The CGT's investment in the antiglobalization movement was partly driven by the need to compensate for the decline of the PCF as well as by the ability of that movement to mobilize large numbers of people in protest events and campaigns. According to the former Secretary General of the textile-apparel workers' federation, "ATTAC manages to mobilize people partly because so far trade unions haven't paid enough attention to globalization. We're late. ATTAC also attracts many youths. I mean, the contrast is obvious: if you organize a meeting of the CGT on a Sunday evening, 10 people show up; for an ATTAC meeting, it will be 300!"³⁰⁴ Some officials thought that in order to take advantage of this potential, the CGT had not only to invest in alliance or linkage-building with the antiglobalization movement but also publicize more its own positions:

The interest of many of our members for NGOs and social movement organizations opposed to globalization such as ATTAC should prompt us to make our own positions more accessible and public. . . . The great majority of our members and workers in general are not familiar with the mechanisms and dynamics of globalization. We should give them concrete information and documents that illustrate our understanding and knowledge of these issues.³⁰⁵

The fact that two of the CGT's direct competitors in the public services sector—the teachers' Unitary Union Federation (Fédération syndicale unitaire, FSU) and, above all, the SUD unions that I presented in Chapter 4—were central actors in the antiglobalization movement reinforced the belief that if the CGT did not invest in it, its competitors would rip all the benefits.

³⁰⁴ Interview with author, April 2003.

³⁰⁵ William Jacquillard, "Permettre à chaque syndiqué de connaître les orientations internationales de la CGT," *Le Peuple* No. 1536, February 7, 2001, p. 19.

The CGT chose to compete with the antiglobalization movement through convergence, that is, by emphasizing similar goals and downplaying disagreements so as to diminish the distinctiveness of its competitors and tap into their niche. So far this tactic has not had a substantial impact on the CGT's membership level. It did, nonetheless, foster unintended tensions, as an increasing number of CGT members were drawn to the antiglobalization movement. For example, in 2001 the person in charge of European affairs at the CGT pointed out that the CGT had to make sure that its involvement in the antiglobalization movement would not confuse its identity and generate internal problems.³⁰⁶ Similarly, another CGT official declared:

we should be neither trailing behind nor opposed to NGOs like ATTAC. We should not be trailing behind because we each have our point of view and our priority should be the quality of trade union relations. We should not be opposed to them because many members of the CGT . . . participate in these organizations for the same reason that they joined the CGT. The issue is not couched in terms of investment or disinvestment, but in terms of a search for points of convergence.³⁰⁷

Such tensions would only increase as the CGT implemented the second tactic—in addition to investing in the antiglobalization movement—it had adopted to increase its leverage and respond to globalization. As I explained in section 4.2.b, the CGT joined the European Trade Union Confederation (ETUC) in 1999. This step introduced a logic that would undermine not only the CGT's previous alignment on the PCF but also its investment in the antiglobalization movement. According to Sophie Bérout (2005: 303), since it joined the ETUC in 1999 the CGT has tried to downplay everything that could

³⁰⁶ Joël Décaillon, "Les enjeux syndicaux en Europe et dans le monde," *Le Peuple* No. 1536, February 7, 2001, p. 14.

³⁰⁷ Michel Doneddu, "Une démarche de conquête de normes sociales," *Le Peuple* No. 1536, February 7, 2001, p. 19-20.

undermine its legitimacy inside the European confederation. Furthermore, “joining the ETUC leads the CGT to rank its alliances and give priority to issues related to internal positions inside the European confederation at the expense of alliances with NGOs, civic associations, and other unions, . . . that together form the nebula of the global justice movement” (Bérout 2005: 306). There thus seems to be a zero-sum relation between moving up the hierarchy of the ETUC and building strong linkages with organizations of the antiglobalization movement.

This tension became obvious during the debate surrounding the May 2005 referendum on the European Constitutional Treaty. In October 2004, the ETUC decided to support the Treaty. The confederal leadership of the CGT did not participate in the vote leading to this decision and thought it would simply inform its members. It was caught between a rock and hard place. Approving the Treaty would lead to a confrontation with several of its workers’ federations and allies in the antiglobalization movement, whereas openly rejecting it would undermine its newly gained influence inside the ETUC. The confederal leadership of the CGT initially tried to hold both ends in the name of unity, that of the CGT and that of the European labor movement. For example, in an ATTAC meeting he attended in October 2004 to plan a protest event in Brussels, Christian Pilichowski, the CGT representative on ATTAC’s Board of Administration, clearly explained that the CGT would not go against the position of the ETUC on grounds that doing so would divide the European labor movement. He asked ATTAC, in vain, to revise its position to foster a strong mobilization in Brussels.³⁰⁸

³⁰⁸ Christian Pilichowski, “Échanges au sujet du texte ‘Stratégie 2005’,” November 9, 2004, retrieved from ATTAC’s website: <http://www.france.attac.org/a3681>.

In spite of the efforts of the confederal leadership, the Confederal National Committee (CCN) of the CGT, where representatives of all workers' federations and department unions seat, decided to officially call for a vote against the Treaty, thereby directly challenging the confederal leadership. CGT Secretary General Bernard Thibault initially responded to the CCN's vote by arguing that rank-and-file members rather than just delegates and officials had to be consulted.³⁰⁹ Nonetheless, at a meeting of the Executive Committee of the ETUC in June 2005, after the Treaty had been rejected by 55 percent of French voters, he pointed out that the majority of French workers opposed the Treaty, particularly blue-collar workers, employees, civil servants, and the unemployed.³¹⁰ Now that the fate of the Treaty was sealed, it could no longer undermine the status of the CGT inside the ETUC.

6 | CONCLUSION

During the era of class politics, the CGT responded to globalization with a radical and offensive strategy that sought to replace capitalism with socialism through the electoral victory of the PCF and its allies. As it experienced organizational failure in the 1980s, it gradually reframed its discourse and identity as well as reconfigured its linkages. As a result, in the early and mid 1990s it engaged in a resistance strategy that tried to stop globalization through a defense of the state and new linkages with both the

³⁰⁹ Hervé Nathan and François Wenz-Dumas, "La CGT ne peut pas se substituer aux partis," *Libération*, February 21, 2005.

³¹⁰ Bernard Thibault, "Comité exécutif de la CES, Bruxelles, 14-15 juin 2005," in CGT, *La CGT et l'Europe dans la mondialisation* (Paris: CGT, 2005): 22.

antiglobalization movement and the European Trade Union Confederation (ETUC). The CGT's current response to globalization could thus not have been predicted by looking at its past record. Similarly, it could not have been predicted by looking only at the social composition of its membership. The latter is based overwhelmingly in the public sector, particularly public services, that is, sectors that are not affected by international trade and capital mobility.

In this chapter, I have tried to show that the trajectory of the CGT stemmed from three factors. First, a given set of initial conditions—a homogeneous organizational repertoire and a single strong linkage—that limited the range of options that the CGT could conceive or choose. Second, a critical juncture, in the form of organizational failure, that opened a space for change. And third, a political-organizational process of change and stabilization that determined the extent to which the CGT would depart from its previous path and respond differently to globalization today.

This last step is crucial. It was the actors' engagement in bricolage that initiated the process of change and indicated the direction it would take. This process was contentious as actors favored different ways of recombining the resources that the organizational repertoire and linkages of the CGT provided. The changes made were consolidated by the opening of the organizational opportunity structure of the CGT. This opening made it difficult for the CGT to return to its previous practices. In doing so, it contributed to stabilizing the path departure of the CGT.

Finally, the specific way in which bricolage, identity shift, and the opening of the organizational opportunity structure took place shaped the outcome. In contrast to the CFDT, which changed through conversion, the CGT changed through a process of layering

that brought about a dynamic of differential growth (cf. Streeck and Thelen 2005: 24). The new layers—the reframing of the CGT’s discourse and identity and the reconfiguration of its linkages—introduced a different logic and dynamic that grew at the expense of the former, institutionalized one embodied in the strong exclusive linkage with the PCF. The more the CGT invested in the ETUC and the antiglobalization movement, the less it could return to the previous logic. Differential growth did not lock the CGT in a new path but consolidated its departure from the previous one.

Organizational Pathways and the Politics of Globalization

This dissertation began with a puzzle. How come two labor organizations with relatively similar social constituencies respond differently to globalization? In trying to answer this question, this study has shown that responses to globalization are formed and transformed over time as the environment of organizations changes and intraorganizational struggles unfold. This process of response (trans)formation is path dependent not because it is the outcome of temporarily remote causes but because it stems from a sequence of events that resulted from an initial contingent event (organizational failure) and has deterministic properties (cf. Mahoney 2000). These deterministic properties lie in the inertial quality of pathways. As Andrew Abbott (2001: 248) remarks, “What makes the trajectories trajectories is their inertial quality, their quality of enduring large amounts of minor variation without any appreciable change in over all direction or regime.” Therefore, accounting for current responses to globalization requires that we trace back their formation and identify the specific events and mechanisms that led them to depart from their previous path and stay on a new one afterward.

This dissertation has shown that in France the formation of labor responses to globalization stemmed from a path dependent process constituted by three different steps. First, organizational failure, illustrated by a sharp membership drop, implied a critical juncture that fed intraorganizational struggles and opened the way for a reorientation of labor organizations. In contrast to what some authors have hypothesized (e.g., Fligstein 1996: 668-669, 2001: 118), in this process incumbents did not necessarily choose to defend the status quo. This was particularly the case in the CFDT, where the confederal leadership was the most fervent proponent of change. Organizational failure provided to an entrepreneurial leadership the opportunity to question past strategic compromises, advance a new agenda, and marginalize internal opponents.

Second, once the crisis was acknowledged, whether organizations would take the path to adaptation or resistance depended on three factors: (1) resources—organizational repertoire and linkages—inherited from the past that limit the range of options that actors can conceive and choose; although these legacies did not directly determine the organizational pathways of the CFDT and the CGT, they did have a lasting structuring effect on them; (2) the presence and content of two mechanisms of change—bricolage and identity shift—that describe how actors used their inherited resources; such mechanisms matter because actors can generate several distinct combinations out of a single set of resources; not specifying these mechanisms implies giving a determining property to resources and legacies; and (3) the ability of leaders to articulate a narrative that would appeal to enough people inside their organizations so as to induce cooperation (cf. Fligstein 2001: 113).

Together, these three factors account for the logic of organizational change that the CFDT and the CGT experienced through the 1980s and early 1990s. The heterogeneity of the CFDT's repertoire and the relative breadth of its linkages allowed a skilled confederal leadership to engage in a far reaching process of bricolage and identity shift that implied the conversion of the CFDT. In contrast, the homogeneity of the CGT's repertoire and its dependence on a single exclusive linkage with the Communist Party (PCF) forced the confederal leadership to engage in an incremental and limited process of bricolage and identity shift that involved change through layering.

The third and last step of the path dependent process that brought about the transformation of labor responses to globalization refers to the stabilization of the new path that the CFDT and the CGT had taken. This is a crucial part of the explanation, for as I mentioned above, the deterministic property of path-dependent sequences lies in the inertial quality of pathways. The latter have to last to generate an effect. The central mechanism that stabilized the paths of the CFDT and the CGT was a shift in the organizational opportunity structure. Although labor organizations were not completely locked in the new path, once the organizational opportunity structure had shifted it was very difficult to return to the previous path or engage in a substantially different one. Therefore, I contend that unless another critical juncture takes place, the CFDT and the CGT are likely to stick with their current responses to globalization for many years.

Contributions

On the basis of this research, this dissertation contributes to three debates. First, it joins recent calls for an organizational approach to social movements and a social movement approach to organizations (Davis et al 2005, Fligstein 1996, Frege and Kelly 2004, Turner 2005). This call has been particularly important in the field of trade union studies (Baccaro, Hamann, and Lowell 2003, Fantasia and Voss 2003, Frege and Kelly 2004, Levi and Murphy 2002, Turner 2005, Voss and Sherman 2000). As a result of the new dynamism and revitalization of the American labor movement since 1995 and the emergence of new labor-NGO coalitions throughout the world around issues related to globalization (from offshoring to labor standards and the WTO), these scholars have questioned approaches depicting unions as an interest group and turned instead to social movement theory to account for the mobilization and strategies of unions.

In this dissertation, I have developed a theoretical framework that builds on the concepts of the political process model in social movement theory (cf. Tarrow 1998, Tilly 1978) so as to approach labor collective action as a process of resource mobilization constrained by institutional and political factors. This framework provides potential tools to students of labor revitalization insofar as it identifies the inherited factors that enable and constrain organized labor as well as the causal mechanisms that can explain the reorientation and trajectory of labor organizations. For example, in the 1990s the American labor movement reached a tipping point in its decline that generated a critical juncture (Turner 2005: 385). This opening, in turn, allowed new leaders to emerge and engage in

bricolage and identity shift, by articulating a discourse on social movement unionism as opposed to business unionism.

The second debate in which this dissertation participates has to do with the political economy of globalization. This debate is dominated by neo-classical trade models (Alt et al 1996, Frieden 1991, Hiscox 2002, Milner 1999, Rogowski 1989) that focus on individual factor endowment and institutionalist accounts (Berger 2000, Berger and Dore 1996, Golden 2000, Kitschelt et al 1999, Scruggs and Lange 2002) that stress cross national variations. Although these two perspectives often shed some light on responses to globalization, they each suffer from a flaw.

Scholars using neo-classical trade models adopt a purely ahistorical perspective insofar as they take a “‘snapshot’ view of political life” (cf. Pierson 2004: 2). They assume that current responses stem from current causes. In contrast, by approaching responses to globalization as a process of strategy formation, this dissertation takes the temporal dimension of collective action seriously and historicizes the politics of globalization. In doing so, it can account for outcomes shaped not only by current causes but also by temporal processes or causal sequences. For example, as I have shown in chapters 5 and 6, the very manner in which the CFDT and the CGT changed—through conversion and layering—brought about unintended effects that affected responses to globalization but could not have been explained by looking only at present causes.

Scholars building on the institutionalist perspective are less likely to suffer from this ahistorical bias. For them, the risk is to fall into a new form of determinism in which national institutions are all mighty. National institutions matter, there is no question about that. The fact that responses to globalization vary consistently across countries indicates

their weight. However, the diverging responses of the CFDT and the CGT suggest that we have to look beyond national institutions so as to take into account organizational factors and, more importantly, the agency of actors. The latter do not simply react to changes in their environment as filtered by national institutions. First, institutions are malleable insofar as the resources that they provide can be used to bend, stretch, or even break the rules of the game (cf. Piven and Cloward 2005, Samuels 2003). Second, actors can recombine these resources and their own in different ways. It is the very core of the idea of bricolage. Even in situations of limited resources, actors can innovate from old materials. Bricolage also lies at the core of the process of path switching during critical junctures, for paths do not simply stand there, waiting to be chosen. They have to be generated from the materials at hand (Djelic and Quack 2007).

This dissertation contributes to specifying the mechanisms of change that are often overlooked by institutionalist accounts and the path dependency literature. The latter tend to focus on reproduction and are often ill equipped conceptually to trace change (Djelic and Quack 2007, Pierson 2004, Thelen 2003). Increasing returns, policy feedback, complementarities, socialization, etc., can explain stability but not change. New mechanisms are needed. Here, building on, among others, Campbell (2004), Lévi-Strauss (1962), and Tilly and Tarrow (2007), I have introduced bricolage and identity shift. But a lot of work is still needed to better specify these two mechanisms. For example, it would be useful to distinguish different types of bricolage and explain how they relate to processes of hybridization of organizational and institutional forms.

Finally, the third contribution of this dissertation relates to the usefulness of mechanisms and path dependency analysis. Is the latter merely sophisticated, post hoc

storytelling? On the one hand, the fact that responses are formed and transformed over time implies that they cannot be predicted. Their destination is unknown. As Abbott (2001: 250) points out, “neither the beginning nor the end of a turning point can be defined until the whole turning point has passed, since it is the arrival and establishment of a new trajectory . . . that defines the turning point itself. This means that turning point analysis makes sense only after the fact, when a new trajectory . . . is clearly established.” Similarly, Djelic and Quack (2007: 168) note that one cannot predict accurately the ultimate shape and destination of a path. They can only be described post hoc.

Although I appreciate such observations, I think that path dependency analysis can make a contribution beyond description after the fact. First, by identifying mechanisms it can turn correlation into real causal accounts. Change may not be predicted but at least it can be explained. Second, as Pierson (2004: 156) remarks, certain configurations make certain logics of change more likely. For example, if there are strong internal barriers to change, an organization is more likely to change through layering than conversion. Inversely, if internal barriers are low, conversion becomes a viable option. Although the CFDT and the CGT both faced an environment that was biased in favor of the status quo and did not favor change, they each had different internal barriers that pushed them toward different logics of change. Therefore, one may not be able to predict how a given organization or institution will change, but it is possible to say how it is *unlikely* to change. It is already a step in the right direction.

BIBLIOGRAPHY

- Abbott, Andrew. 2001. *Time Matters: On Theory and Method*. Chicago: University of Chicago Press.
- Abdelal, Rawi. 2006. "Writing the rules of global finance: France, Europe, and capital liberalization." *Review of International Political Economy* Vol. 13 (1): 1-27.
- Abdelal, Rawi, and Sophie Meunier. 2006. "La Règle du jeu: France and the Paradox of Managed Globalization." Paper presented at the annual meeting of the American Political Science Association, Philadelphia, PA.
- Agrikoliansky, Eric. 2005. "Du tiers-mondisme à l'altermondialisme: Genèse(s) d'une nouvelle cause." In E. Agrikoliansky, O. Fillieule, and N. Mayer, eds. *L'Altermondialisme en France: La longue histoire d'une nouvelle cause*. Paris: Flammarion.
- Agrikoliansky, Eric, Olivier Fillieule, and Nonna Mayer, eds. 2005. *L'Altermondialisme en France: La longue histoire d'une nouvelle cause*. Paris: Flammarion.
- Alt, James E. et al. 1996. "The Political Economy of International Trade: Enduring Puzzles and an Agenda for Inquiry." *Comparative Political Studies* Vol. 29 (6): 689-717.
- Amenta, Edwin, and Michael P. Young. 1999. "Making an Impact: Conceptual and Methodological Implications of the Collective Goods Criterion." In M. Giugni, D. McAdam, and C. Tilly, eds. *How Social Movements Matter*. Minneapolis: University of Minnesota Press.
- Ancelevici, Marcos. 2002. "Organizing against Globalization: The Case of ATTAC in France." *Politics and Society* Vol. 30 (3): 427-63.
- Andolfatto, Dominique. 1995. *La syndicalisation en France depuis 1945: Le personnel dirigeant de la CGT (1944-1996)*. CERAT, Institut d'études politiques de Grenoble.
- . 2001. "L'univers syndical: Étude comparée de la CGT et de la CFDT." In D. Labbé and S. Courtois, eds. *Regards sur la crise du syndicalisme*. Paris: L'Harmattan.
- Andolfatto, Dominique, and Dominique Labbé. 1997. *La CGT: Organisation et audience depuis 1945*. Paris: La Découverte.
- . 2006a. *Histoire des syndicats (1906-2006)*. Paris: Seuil.
- . 2006b. "Faut-il aider les syndicats français?" *Le Débat* No. 142: 119-32.

- . 2007. “Les syndiqués en France: 1990-2006.” Report prepared for the DARES, French Government, 175 p.
- Andolfatto, Dominique, and Régis Matuszewicz. 2004. “L’audience électorale du syndicalisme.” In D. Andolfatto, ed. *Les syndicats en France*. Paris : La Documentation Française.
- Ansell, Christopher K. 1997. “Symbolic Networks: The Realignment of the French Working Class, 1887-1894.” *American Journal of Sociology* Vol. 103 (2): 359-90.
- . 2001. *Schism and Solidarity in Social Movements: The Politics of Labor in the French Third Republic*. New York: Cambridge University Press.
- Aparicio Jean-Claude, Michel Pernet, and Daniel Torquéo. 1999. *La CFDT au peril du liberal-syndicalisme*. Paris: Syllepse.
- ATTAC. 2000a. *Tout sur ATTAC*. Paris: Mille et une nuits.
- . 2000b. *Les Paradis fiscaux ou la finance sans loi*. Paris: Mille et une nuits.
- . 2001a. *Enquête au coeur des multinationales*. Paris: Mille et une nuits.
- . 2001b. *Remettre l’OMC à sa place*. Paris: Mille et une nuits.
- . 2002a. *Tout sur ATTAC 2002*. Paris: Mille et une nuits.
- . 2002b. *Que faire du FMI et de la Banque mondiale?* Paris: Mille et une nuits.
- . 2003a. *Le G8 illégitime*. Paris: Mille et une nuits.
- . 2003b. *Quand les femmes se heurtent à la mondialisation*. Paris: Mille et une nuits.
- . 2003c. *Travailleurs précaires, unissez-vous!* Paris: Mille et une nuits.
- . 2006. *Pauvreté et inégalités: Ces creatures du néolibéralisme*. Paris: Mille et une nuits.
- Aveni, Adrian F. 1978. “Organizational Linkages and Resource Mobilization: The Significance of Linkage Strength and Breadth.” *The Sociological Quarterly* Vol. 19 (2): 185-202.
- Baccaro, Lucio, Kerstin Hamann, and Lowell Turner. 2003. “The Politics of Labour Movement Revitalization: The Need for a Revitalized Perspective.” *European Journal of Industrial Relations* Vol. 9 (1): 119-33.
- Balme, Richard. 2006. “Convergence, Fragmentation and Majority-Cycling in French Public Opinion.” In P. D. Culpepper, P. A. Hall, and B. Palier, eds. *Changing France: The Politics that Markets Make*. Houndmills, UK: Palgrave.
- Barman, Emily A. 2002. “Asserting Difference: The Strategic Response of Nonprofit Organizations to Competition.” *Social Forces* Vol. 80 (4): 1191-1222.
- Bartolini, Stefano. 2000. *The Political Mobilization of the European Left, 1860-1980: The Class Cleavage*. New York: Cambridge University Press.
- Benford, Robert D. 1997. “An Insider’s Critique of the Social Movement Framing Perspective.” *Sociological Inquiry* Vol. 67 (4) : 409-430.

- Bennett, Andrew. 1999. "Causal Inference in Case Studies: From Mill's Methods to Causal Mechanisms." Paper presented at the American Political Science Association annual meeting, Atlanta, GA.
- Bennett, Andrew, and Alexander L. George. 1997. "Process Tracing in Case Study Research." Paper presented at the MacArthur Foundation Workshop on Case Study Methods, Belfer Center for Science and International Affairs, Harvard University, October 17-19.
- Berger, Suzanne. 1972. *Peasants against Politics: Rural Organization in Brittany, 1911-1967*. Cambridge, MA: Harvard University Press.
- . 1974. *The French Political System*. New York: Random House.
- . 1979. "Politics and Antipolitics in Western Europe in the Seventies," *Daedalus* Vol. 108 (1): 27-50.
- . 1987. "Religious transformation and the future of politics." In C. S. Maier, ed. *Changing boundaries of the political: Essays on the evolving balance between the state and society, public and private in Europe*. New York: Cambridge University Press.
- . 2000. "Globalization and Politics." *Annual Review of Political Science* Vol. 3: 43-62.
- . 2002. "French Democracy without Borders?" *French Politics, Culture & Society* Vol. 20 (1): 1-12.
- . 2003. *Notre première mondialisation*. Paris: Seuil.
- . 2005. *How We Compete: What Companies Around the World Are Doing to Make It in Today's Global Economy*. New York: Currency.
- Berger, Suzanne and Ronald Dore. 1996. *National Diversity and Global Capitalism*. Ithaca, NY: Cornell University Press.
- Berman, Sheri. 1998. "Path Dependency and Political Action: Reexamining Responses to the Depression." *Comparative Politics* Vol. 30 (4): 379-400.
- Bérourd, Sophie. 2002. "La rébellion salariale." In X. Crettiez and I. Sommier, eds. *La France rebelle*. Paris: Michalon.
- . 2005. "La CGT, entre soutien distancé et refondation de l'activité internationale." In E. Agrikoliansky, O. Fillieule, and N. Mayer, eds. *L'Altermondialisme en France: La longue histoire d'une nouvelle cause*. Paris: Flammarion.
- Bérourd, Sophie, René Mouriaux, and Michel Vakaloulis. 1998. *Le Mouvement social en France: Essai de sociologie politique*. Paris: La Dispute.
- Birchfield, Vicki. 2005. "José Bové and the globalisation countermovement in France and beyond: a Polanyian interpretation." *Review of International Studies* Vol. 31 (3): 581-98.

- Birchfield, Vicki, and Annette Freyberg-Inan. 2004. "Constructing Opposition in the Age of Globalization: The Potential of ATTAC." *Globalizations* Vol. 1 (2): 278-304.
- Biscourd, Pierre, and Francis Kramarz. 2003. "Internationalisation des entreprises industrielles et emploi: une analyse sur la période 1986-1992." *Économie et Statistique* No. 363-364-365: 69-95.
- Blyth, Mark, and Richard S. Katz. 2005. "From Catch all Politics to Cartelization: The Political Economy of the Cartel Party." *Western European Politics* Vol. 28 (1): 34-61.
- Boltanski, Luc. 1993. *La Souffrance à distance: Morale humanitaire, médias et politique*. Paris: Editions Métailié.
- Boltanski, Luc, and Eve Chiapello. 1999. *Le Nouvel esprit du capitalisme*. Paris: Gallimard.
- Bourdieu, Pierre. 1998. *Contre-feux: Propos pour servir à la résistance contre l'invasion néo-libérale*. Paris: Liber-Raisons d'agir.
- Bourdieu, Pierre (with Loïc J. D. Wacquant). 1992. *Réponses: Pour une anthropologie réflexive*. Paris : Seuil.
- Boyer, Robert. 1984. "Rapport salarial, accumulation et crise: 1968-1982." In M. Kesselman, ed. *1968-1982. Le mouvement ouvrier français: crise économique et changement politique*. Paris: Les Éditions ouvrières.
- . 2004. *Une théorie du capitalisme est-elle possible?* Paris: Odile Jacob.
- Brady, David. 2007. "Institutional, Economic, or Solidaristic? Assessing Explanations for Unionization Across Affluent Democracies." *Work and Occupation* Vol. 34 (1): 67-101.
- Brady, David, Jason Beckfield, and Wei Zhao. 2007. "The Consequences of Economic Globalization for Affluent Democracies." *Annual Sociological Review* Vol. 33: 313-34.
- Brady, David, and Ryan Denniston. 2006. "Economic Globalization, Industrialization and Deindustrialization in Affluent Democracies." *Social Forces* Vol. 85 (1): 297-329.
- Branciard, Michel, and Patrick venturini. 1986. "Le syndicalisme CFTC-CFDT et l'économie, 1946-1981." BRAEC, Secteur Action économique-Emploi, CFDT.
- Bridgford, Jeff. 1991. *The Politics of French Trade Unionism*. Leicester, UK: Leicester University Press.
- Bruner, Jerome. 1991. "The Narrative Construction of Reality." *Critical Inquiry* Vol. 1 (18): 1-21.
- Campbell, John. 2004. *Institutional Change and Globalization*. Princeton, NJ: Princeton University Press.
- Canto-Sperber, Monique. 2003. *Les règles de la liberté*. Paris: Plon.
- Capdevielle, Jacques. 2001. *Modernité du corporatisme*. Paris: Presses de Science Po.

- Cassen, Bernard. 1997. "To Save Society." Paper presented at the conference "Is Globalisation Inevitable and Desirable?" London School of Economics, UK. 7 May.
- . 2003. *Tout a commencé à Porto Alegre... Mille forums sociaux!* Paris: Mille et une nuits.
- Castells, Manuel. 1997. *The Information Age, Vol. 2: The Power of Identity*. Oxford: Blackwell.
- Cefai, Daniel, and Danny Trom, eds. 2001. *Les Formes de l'action collective: Mobilisations dans des arènes publiques*. Paris: Editions de l'Ecole des Hautes Etudes en Sciences Sociales.
- Chandra, Kanchan. 2006. "Mechanisms v/s Outcomes." *Qualitative Methods Newsletter* Vol. 4 (1), Qualitative Methods Section, American Political Science Association, Washington, DC.
- Chauvel, Louis. 2001. "Le retour des classes sociales?" *Revue de l'OFCE* No. 79: 315-59.
- Chérèque, François. 2002. *Qu'est-ce que la CFDT?* Paris: l'Archipel.
- Clark, Terry Nichols, and Seymour M. Lipset. 1991. "Are Social Classes Dying?" *International Sociology* Vol. 6 (4): 397-410.
- . eds. 2001. *The Breakdown of Class Politics: A Debate on Post-Industrial Stratification*. Washington, DC/Baltimore, MD: Woodrow Wilson Center Press/Johns Hopkins University Press.
- Clemens, Elisabeth S. 1996. "Organizational form as frame: Collective identity and political strategy in the American labor movement, 1880-1920." In D. McAdam, J. D. McCarthy, and M. N. Zald, eds. *Comparative Perspectives on Social Movements*. New York: Cambridge University Press.
- Cohen, Elie. 1995. *La Tentation hexagonale*. Paris: Fayard.
- Cole, Alistair. 1999. "The Service Public Under Stress." *West European Politics* Vol. 22 (4): 166-184.
- Contamin, Jean-Gabriel. 2005. "Les grèves décembre 1995: Un moment fondateur?" In E. Agrikoliansky, O. Fillieule, and N. Mayer, eds. *L'Altermondialisme en France: La longue histoire d'une nouvelle cause*. Paris: Flammarion.
- Coupé, Annick, and Anne Marchand, eds. 1998. *SUD, syndicalement incorrect: Sud-Ptt, une aventure collective*. Paris: Syllepse.
- Courtois, Stéphane, and Marc Lazar. 2000. [1995] *Histoire du Parti communiste français*. Paris: Presses universitaires de France.
- Cox, Robert W. 1979. "Ideologies and the New International Economic Order: Reflections on some recent literature." *International Organization* Vol. 33 (2): 257-302.
- Crouch, Colin. 2005. *Capitalist Diversity and Change: Recombinant Governance and Institutional Entrepreneurs*. New York, NY: Oxford University Press.

- Crouch, Colin, and Henry Farrell. 2004. "Breaking the Path of Institutional Development? Alternatives to the New Determinism." *Rationality and Society* Vol. 16 (1): 5-43.
- Curtis, Russell L., and Louis A. Zurcher. 1973. "Stable Resources of Protest Movements: The Multi-Organizational Field." *Social Forces* Vol. 52 (1): 53-61.
- Dalton, Benjamin. 2004. "Creativity, Habit, and the Social Products of Creative Action: Revising Joas, Incorporating Bourdieu." *Sociological Theory* Vol. 22 (4): 603-22.
- Dalton, Russel J., and Manfred Kuechler, eds. 1990. *Challenging the Political Order: New Social and Political Movements in Western Democracies*. Cambridge, UK: Polity Press.
- Dandé, Serge. 2003. "Le PCF et l'autogestion: Histoire d'un ralliement, 1968-1979." In F. Georgi, ed. *Autogestion. La dernière utopie?* Paris: Publications de la Sorbonne.
- Davis, Gerald F., et al, eds. 2005. *Social Movements and Organization Theory*. New York : Cambridge University Press.
- Daudin, Guillaume, and Sandrine Levasseur. 2005. "Measuring the Effect of International Relocations on French Economy." Paris: OFCE.
- Della Porta, Donatella. 2003. "Social Movements and Democracy at the Turn of the Millennium: The Italian Case." In P. Ibarra, ed. *Social Movements and Democracy*. New York: Palgrave Macmillan.
- . 2005. "The Social Bases of the Global Justice Movement: Some Theoretical Reflections and Empirical Evidence from the First European Social Forum." Programme Paper Number 21, Civil Society and Social movements, United Nations Research Institute for Social Development (UNRISD).
- Della Porta, Donatella, and Mario Diani. 1999. *Social Movements: An Introduction*. Oxford: Blackwell.
- Della Porta, Donatella, and Mario Diani. 2006 [1999]. *Social Movements: An Introduction* (2nd ed.). Oxford: Blackwell.
- Della Porta, Donatella, and Sidney Tarrow, eds. 2004. *Transnational Protest and Global Activism*. Lanham, MD: Rowman and Littlefield.
- Della Porta, Donatella, et al. 2006. *Globalization from Below: Transnational Activists and Protest Networks*. Minneapolis, MN: University of Minnesota Press.
- Denis, Jean-Michel. 2001. *Le Groupe des dix: Un modèle syndical alternative?* Paris: La Documentation française.
- Diani, Mario. 2000. "Simmel to Rokkan and Beyond: Towards a Network Theory of (New) Social Movements," *European Journal of Social Theory* Vol. 3 (4): 387-406.
- Djelic, Marie-Laure, and Sigrid Quack. 2007. "Overcoming path dependency: path generation in open systems." *Theory and Society* Vol. 36 (2): 161-186.
- Doyle, Michael W. 1983. "Stalemate in the North-South Debate: Strategies and the New International Economic Order." *World Politics* Vol. 35 (3): 426-64.

- Dreiling, Michael, and Ian Robinson. 1998. "Union Responses to NAFTA in the US and Canada: Explaining Intra- and International Variation." *Mobilization* Vol. 3 (2): 163-184.
- Duménil, Gérard, and Dominique Plihon. 2006. "Libre-échange." ATTAC. Retrieved from the Internet at <http://www.france.attac.org/a6037>.
- Ebbinghaus, Bernhard. 1993. *Labor Unity in Union Diversity: Trade Unions and Social Cleavages in Western Europe, 1890-1989*. Ph.D. Dissertation, Department of Political and Social Sciences, European University Institute, Florence, Italy.
- . 1996. "From ideology to organization: The transformation of political unionism in Western Europe." In P. Pasture, J. Verberckmoes, and H. DeWitte, eds. *The Lost Perspective? Trade Unions Between Ideology and Social Action in the New Europe*. Volume 2. Aldershot: Avebury.
- . 2002a. "Globalization and Trade Unions: A Comparative-Historical Examination of the Convergence Thesis." *Économie appliquée* Vol. 40 (2): 121-139.
- . 2002b. "Trade unions' changing role: membership erosion, organizational reform, and social partnership in Europe." *Industrial Relations Journal* Vol. 33 (5): 465-83.
- . 2005. *Can Path Dependence Explain Institutional Change? Two Approaches Applied to Welfare State Reform*. MPfG Discussion Paper 05/2. Max Planck Institute for the Study of Societies, Cologne, Germany.
- Ebbinghaus, Bernhard, and Jelle Visser. 1999. "When Institutions Matter: Union Growth and Decline in Western Europe, 1950-1995." *European Sociological Review* Vol. 15 (2): 135-58.
- . 2000. "A Comparative Profile." In B. Ebbinghaus and J. Visser, eds. *The Societies of Europe: Trade Unions in Western Europe since 1945*. London, UK: Macmillan.
- Esping-Andersen, Gøsta. 1999. "Politics without Class: Postindustrial Cleavages in Europe and America." In H. Kitschelt et al, eds. *Continuity and Change in Contemporary Capitalism*. New York: Cambridge University Press.
- Eurobarometer. 2003. "Globalization." Flash Eurobarometer 151b. Available at http://ec.europa.eu/public_opinion/flash/FL151bGlobalisationREPORT.pdf.
- Evans, Geoffrey, ed. 1999. *The End of Class Politics? Class Voting in Comparative Context*. Oxford: Oxford University Press.
- Evans, Peter. 2005. "Counter-Hegemonic Globalization: Transnational Social Movements in the Global Political Economy." In T. Janoski, R. Alford, A. Hicks, and M. Schwartz, eds. *The Handbook of Political Sociology*. New York: Cambridge University Press.
- Fantasia, Rick, and Kim Voss. 2003. *Des syndicats domestiqués: Répression patronale et résistance syndicale aux Etats-Unis*. Paris: Raisons d'agir.

- Fligstein, Neil. 1987. "The Intraorganizational Power Struggle: Rise of Finance Personnel to Top Leadership in Large Corporations, 1919-1979." *American Sociological Review* Vol. 52 (1): 44-58.
- . 1991. "The Structural Transformation of American Industry: An Institutional Account of the Causes of Diversification in the Largest Firms, 1919-1979." In W. W. Powel and P. J. DiMaggio, eds. *The New Institutionalism in Organizational Analysis*. Chicago: University of Chicago Press.
- . 1996. "Market as Politics: A Political-Cultural Approach to Market Institutions." *American Sociological Review* Vol. 61 (4): 656-73.
- . 2001. "Social Skills and the Theory of Fields." *Sociological Theory* Vol. 19 (2): 105-25.
- . 2006. "Organizations: Theoretical Debates and the Scope of Organizational Theory." In C. Calhoun, C. Rojek, and B. S. Turner, eds. *The Sage Handbook of Sociology*. London: Sage.
- Fontagné, Lionel, and Jean-Hervé Lorenzi. 2005. *Désindustrialisation, délocalisations*. Paris: La Documentation française.
- Frege, Carola, and John Kelly, eds. 2004. *Varieties of Unionism: Strategies for Union Revitalization in a Globalizing Economy*. Oxford, UK: Oxford University Press.
- Frege, Carola, Edmund Heery, and Lowell Turner. 2004. "The New Solidarity? Trade Union Coalition-Building in Five Countries." In C. Frege and J. Kelly, eds. *Varieties of Unionism: Strategies for Union Revitalization in a Globalizing Economy*. Oxford, UK: Oxford University Press.
- Frieden, Jeffrey A. 1991. "Invested Interests: The Politics of National Economic Policies in a World of Global Finance." *International Organization* Vol. 45 (4): 425-52.
- Garrett, Geoffrey. 1998. *Partisan Politics in the Global Economy*. New York: Cambridge University Press.
- Garrett, Geoffrey, and Peter Lange. 1991. "Political responses to interdependence: what's 'left' for the left?" *International Organization* Vol. 45 (4): 539-64.
- Garud, Raghu, and Peter Karnøe. 2001. "Path Creation as a Process of Mindful Deviation." In R. Garud and P. Karnøe, eds. *Path Dependence and Creation*. Lawrence Erlbaum Associates. Available online at: <http://pages.stern.nyu.edu/~rgarud/path/PATHC.PDF>
- Geertz, Clifford. 1973. *The Interpretation of Cultures*. New York: BasicBooks.
- George, Alexander L., and Andrew Bennett. 2005. *Case Studies and Theory Development in the Social Sciences*. Cambridge, MA: MIT Press.
- Georgi, Frank, ed. 2003. *Autogestion, la dernière utopie?*. Paris: Publications de la Sorbonne.

- . 2004. “La CFDT et les associations du ‘nouveau social’ des années 1970 à nos jours.” Paper presented at the conference “Syndicats et associations en France: Concurrence ou complémentarité?” Paris. November 25-26.
- Gerhards, Jürgen, and Dieter Rucht. 1992. “Mesomobilization: Organizing and Framing in Two Protest Campaigns in West Germany.” *American Journal of Sociology* Vol. 98 (3): 555-596.
- Giddens, Anthony. 2000. *The Third Way and its Critics*. London: Polity Press.
- Giugni, Marco. 1999. “How Social Movements Matter: Past Research, Present Problems, Future Developments.” In M. Giugni, D. McAdam, and C. Tilly, eds. *How Social Movements Matter*. Minneapolis: University of Minnesota Press.
- Gobille, Boris, and Aysen Uysal. 2005. “Cosmopolites et enracinés.” In E. Agrikoliansky and I. Sommier, eds. *Radiographie du mouvement altermondialiste: Forum social européen 2003*. Paris: La Dispute.
- Goetschy, Janine. 1998. “France: The Limits of Reform.” In A. Ferner and R. Hyman, eds. *Changing Industrial Relations in Europe*. Oxford, UK: Blackwell.
- Golden, Miriam. 1992. “Conclusion: Currents Trends in Trade Union Politics.” In M. Golden and J. Pontusson, eds. *Bargaining for Change: Union Politics in North America and Europe*. Ithaca, NY: Cornell University Press.
- . 1997. *Heroic Defeats: The Politics of Job Loss*. New York: Cambridge University Press.
- . 2000. “Is Increasing International Economic Integration Bad for Labor?” Unpublished Ms., Department of Political Science, University of California, Los Angeles.
- Golden, Miriam, and John Londregan. 1998. “Globalization and Industrial Relations.” Unpublished Ms., Department of Political Science, University of California, Los Angeles.
- Golden, Miriam, Michael Wallerstein, and Peter Lange. 1999. “Postwar Trade-Union Organization and Industrial Relations in Twelve Countries.” In H. Kitschelt et al, eds. *Continuity and Change in Contemporary Capitalism*. New York: Cambridge University Press.
- Goldstein, Judith, and Robert O. Keohane. 1993. “Ideas and Foreign Policy: An Analytical Framework.” In J. Goldstein and R. O. Keohane, eds. *Ideas and Foreign Policy: Beliefs, Institutions, and Political Change*. Ithaca, NY: Cornell University Press.
- Goldstone, Jack A. 1998. “Initial Conditions, General Laws, Path Dependence, and Explanation in Historical Sociology.” *American Journal of Sociology* Vol. 104 (3): 829-45.
- . 2003. “Bridging Institutionalized and Noninstitutionalized Politics.” In J. A. Goldstone, ed. 2003. *States, Parties, and Social Movements*. New York: Cambridge University Press.

- Goldthorpe, John H. 2002. "Globalisation and Social Class." *West European Politics* Vol. 25 (3): 1-28.
- Gordon, Philip H., and Sophie Meunier. 2001. *The French Challenge: Adapting to Globalization*. Washington, DC: Brookings Institution Press.
- Greenfeld, Liah. 1992. *Nationalism: Five Roads to Modernity*. Cambridge, MA: Harvard University Press.
- Groux, Guy, and René Mouriaux. 1989. *La CFDT*. Paris: Economica.
- Hall, Peter A. 1986. *Governing the Economy: The Politics of State Intervention in Britain and France*. New York: Oxford University Press.
- . 2003. "Aligning Ontology and Methodology in Comparative Research." In J. Mahoney and D. Rueschemeyer, eds. *Comparative Historical Analysis in the Social Sciences*. New York: Cambridge University Press.
- . 2005. "Preference Formation as a Political Process: The Case of Monetary Union in Europe." In I. Katznelson and B. Weingast, eds. *Preferences and Situations: Points of Intersection Between Historical and Rational Choice Institutionalism*. New York: Russell Sage Foundation.
- Hall, Peter A., and David Soskice. 2001. *Varieties of Capitalism: The Institutional Foundations of Comparative Advantage*. Oxford, UK: Oxford University Press.
- Hall, Peter A., and Rosemary C. R. Taylor. 1996. "Political Science and the Three New Institutionalisms." *Political Studies* XLIV: 936-57.
- Hall, Peter A., and Kathleen Thelen. 2006. "Institutional Change in Varieties of Capitalism." Paper presented at the Europeanists Conferences, Chicago, IL. March.
- Hamon, Hervé, and Patrick Rotman. 1984 [1982]. *La deuxième gauche: Histoire intellectuelle de la CFDT*. Paris: Seuil.
- Hanson, Brian. 1998. "What Happened to Fortress Europe? External Trade Policy Liberalization in the European Union." *International Organization* Vol. 52 (1): 55-85.
- Harmel, Robert, and Kenneth Janda. 1994. "An Integrated Theory of Party Goals and Party Change." *Journal of Theoretical Politics* Vol. 6 (3): 259-87.
- Hassenteufel, Patrick. 1991. "Pratiques représentatives et construction identitaire: Une approche des coordinations." *Revue française de science politique* Vol. 41 (1): 5-27.
- Hay, Colin. 2001. "The 'Crisis' of Keynesianism and the Rise of Neoliberalism in Britain." In J. L. Campbell and O. K. Pedersen, eds. *The Rise of Neoliberalism and Institutional Analysis*. Princeton, NJ: Princeton University Press.
- Haydu, Jeffrey. 1998. "Making Use of the Past: Time Periods as Cases to Compare and as Sequences of Problem Solving," *American Journal of Sociology* Vol. 104 (2): 339-71.

- Hazareesingh, Sudhir. 1994. *Political Traditions in Modern France*. Oxford: Oxford University Press.
- Hechter, Michael. 2004. "From Class to Culture." *American Journal of Sociology* Vol. 110 (2): 400-45.
- Hedström, Peter, and Richard Swedberg, eds. 1998. *Social Mechanisms: An Analytical Approach to Social Theory*. New York: Cambridge University Press.
- Heery, Edmund, and Lee Adler. 2004. "Organizing the Unorganized." In C. Frege and J. Kelly, eds. *Varieties of Unionism: Strategies for Union Revitalization in a Globalizing Economy*. Oxford, UK: Oxford University Press.
- Hetzl, Anne-Marie, Josette Lefèvre, René Mouriaux, and Maurice Tournier. 1998. *Le syndicalisme à mots découverts: Dictionnaire des fréquences (1971-1990)*. Paris: Syllepse.
- Hirst, Paul, and Grahame Thompson. 1996. *Globalization in Question : The International Economy and the Possibilities of Governance*. Cambridge, UK : Polity Press.
- Hirschman, Albert O. 1970. *Exit, Voice, and Loyalty: Responses to Decline in Firms, Organizations, and States*. Cambridge, MA: Harvard University Press.
- . 1986. "Rival Views of Market Society." In A. O. Hirschman. *Rival Views of Market Society and Other Recent Essays*. Cambridge, MA: Harvard University Press.
- Hiscox, Michael J. 2002. *International Trade and Political Conflict: Commerce, Coalitions, and Mobility*. Princeton, NJ: Princeton University Press.
- Hoffmann, Stanley, George Ross, and Sylvia Malzacher, eds. *The Mitterrand Experiment: Continuity and Change in Socialist France*. Oxford: Polity Press.
- Hooghe, Liesbet, and Gary Marks. 1999. "The Making of a Polity: The Struggle over European Integration." In H. Kitschelt et al, eds. *Continuity and Change in Contemporary Capitalism*. New York: Cambridge University Press.
- Howell, Chris. 1992a. *Regulating Labor: The State and Industrial Relations Reform in Postwar France*. Princeton, NJ: Princeton University Press.
- . 1992b. "The Contradictions of French Industrial Relations Reform." *Comparative Politics* Vol. 24 (2): 181-97.
- . 2006. "The State and the Reconstruction of Industrial Relations Institutions after Fordism: Britain and France Compared." In J. Levy, ed. *The State after Statism: New State Activities in the Age of Liberalization*. Cambridge, MA: Harvard University Press.
- Huntington, Samuel. 1996. *The Clash of Civilizations and the Remaking of the World Order*. New York: Touchstone/Simon & Schuster.
- Hyman, Richard. 2001. *Understanding European Trade Unionism: Between market, class and society*. London, UK: Sage Publications.

- INSEE. 2006. "L'économie française, 2005-2006: Délocalisations et réductions d'effectifs dans l'industrie française." Paris, France. Available at http://www.insee.fr/fr/ffc/docs_ffc/ECOFRA05b.PDF#search=%22ide%22.
- IFA. 2006. "2005 Report on Foreign Direct Investment in France." Paris, France. Available at http://www.investinfrance.org/France/Newsroom/Publications/publication_2006-05-10_en.pdf.
- Inglehart, Ronald. 1997. *Modernization and Postmodernization: Cultural, Economic, and Political Change in 43 Societies*. Princeton, NJ: Princeton University Press.
- Ivaldi, Gilles. 2006. "Party elite *discursive repertoires* of globalisation, Europeanisation and immigration in France: party system dynamics and the political manufacturing of inexorability and exogenous constraints." Paper presented at the workshop on "Mapping Elite Attitudes to Globalisation, European Integration and Regionalisation," ECPR Joint Sessions of Workshops, Nicosia.
- Jégourel, Yves. 2002. *La taxe Tobin*. Paris: La Découverte.
- Jenkins, J. Craig. 1983. "Resource Mobilization Theory and the Study of Social Movements." *Annual Review of Sociology* Vol. 9: 527-553.
- Jenson, Jane. 1990. "Representation in Crisis: The Roots of Canada's Permeable Fordism." *Canadian Journal of Political Science* Vol. 23 (4): 653-83.
- Johnson, Juliet. 2001. "Path Contingency in Postcommunist Transformations." *Comparative Politics* Vol. 33 (3): 253-74.
- Joshua, Florence, and Yann Raison du Cleuziou. 2005. "Entre apolitisme et radicalité." In E. Agrikoliansky and I. Sommier, eds. *Radiographie du mouvement altermondialiste: Forum social européen 2003*. Paris: La Dispute.
- Kapstein, Ethan B. 1996. "Workers and the World Economy." *Foreign Affairs* Vol. 75 (3): 16-37.
- . 2006. *Economic Justice in an Unfair World*. Princeton, NJ: Princeton University Press.
- Katznelson, Ira, and Barry R. Weingast. 2005. "Intersections Between Historical and Rational Choice Institutionalism." In I. Katznelson and B. Weingast, eds. *Preferences and Situations: Points of Intersection Between Historical and Rational Choice Institutionalism*. New York: Russell Sage Foundation.
- Keck, Margaret E., and Kathryn Sikkink. 1998. *Activists Beyond Borders: Advocacy Networks in International Politics*. Ithaca, NY: Cornell University Press.
- Keohane, Robert O. 1984. "The World Economy and the Crisis of Embedded Liberalism." In J. H. Goldthorpe, ed. *Order and Conflict in Contemporary Capitalism: Studies in the Political Economy of Western European Nations*. Oxford: Clarendon Press.

- King, Gary, Robert O. Keohane, and Sidney Verba. 1994. *Designing Social Inquiry: Scientific Inference in Qualitative Research*. Princeton, NJ: Princeton University Press.
- Kingdon, John W. 2003 [1984]. *Agendas, Alternatives, and Public Policies*. New York: Longman.
- Kitschelt, Herbert. 1993. "Social Movements, Political Parties, and Democratic Theory." *Annals of the American Academy of Political and Social Science* Vol. 528: 13-29.
- . 1994. *The Transformation of European Social Democracy*. New York: Cambridge University Press.
- Kitschelt, Herbert, Peter Lange, Gary Marks, and John D. Stephens, eds. 1999. *Continuity and Change in Contemporary Capitalism*. New York: Cambridge University Press.
- Klandermans, Bert. 1997. *The Social Psychology of Protest*. Oxford, UK: Blackwell.
- . 2001. "Does Class Still Unite? Concluding Remarks." In G. Van Gyes, H. de Witte, and P. Pasture, eds. 2001. *Can Class Still Unite? The differentiated work force, class colidarity and trade unions*. Aldershot, UK: Ashgate.
- Klein, Naomi. 2001. "Reclaiming the Commons." *New Left Review* 9: 81-89.
- Kobrin, Stephen J. 1998. "The MAI and the Clash of Globalizations." *Foreign Policy* No.112: 97-109
- Koelble, Thomas A. 1992. "Recasting Social Democracy in Europe: A Nested Games Explanation of Strategic Adjustment in Political Parties." *Politics and Society* Vol. 20 (1): 51-70.
- Kriesi, Hanspeter, et al. 1995. *New Social Movements in Western Europe: A Comparative Analysis*. Minneapolis, MN: University of Minnesota Press.
- Krugman, Paul. 1997. *Pop Internationalism*. Cambridge, MA: MIT Press.
- . 1998. *The Accidental Theorist and Other Dispatches from the Dismal Science*. New York: W.W. Norton.
- Kuisel, Richard F. 1981. *Capitalism and the State in Modern France*. New York: Cambridge University Press.
- Labbé, Dominique, Maurice Croisat, and Antoine Bévort. 1990. "La désyndicalisation: Le cas de la CFDT." Cahier No 5, CERAT, Institut d'études politiques de Grenoble.
- Laitin, David. 1986. *Hegemony and Culture: The Politics of Religious Change Among the Yoruba*. Chicago: University of Chicago Press.
- Lallement, Michel. 2006. "New Patterns of Industrial Relations and Political Action since the 1980s." In P. D. Culpepper, P A. Hall, and B. Palier, eds. *Changing France: The Politics that Markets Make*. Houndmills, UK: Palgrave.
- Lamont, Michèle, and Laurent Thévenot. 2000. "Introduction: Toward a renewed comparative cultural sociology." In M. Lamont and L. Thévenot, eds. *Rethinking*

Comparative Cultural Sociology: Repertoires of Evaluation in France and the United States. New York: Cambridge University Press.

- Lange, Peter, George Ross, and Maurizio Vannicelli. 1982a. "Introduction." In P. Lange, G. Ross, and M. Vannicelli, eds. *Unions, Change and Crisis: French and Italian Union Strategy and the Political Economy, 1945-1980*. London, UK: George Allen & Unwin.
- . 1982b. "A Summing Up." In P. Lange, G. Ross, and M. Vannicelli, eds. *Unions, Change and Crisis: French and Italian Union Strategy and the Political Economy, 1945-1980*. London, UK: George Allen & Unwin.
- Lavabre, Marie-Claire, and François Platone. 2003. *Que reste-t-il du PCF?* Paris: Autrement.
- Lavau, Georges, 1981. *A quoi sert le Parti communiste français?* Paris: Fayard.
- Le Diugou, Jean-Christophe. 2005. *Demain le changement: Manifeste pour un nouveau syndicalisme*. Paris: Armand Colin.
- Levi, Margaret, and Gillian Murphy. 2002. "Coalitions of Contention: The Case of the WTO Protests in Seattle." Paper prepared for the 15th World Congress of the International Sociological Association, Brisbane, 7–13 July.
- Lévi-Strauss, Claude. 1962. *La Pensée sauvage*. Paris: Plon.
- Levy, Jonah. 1999. *Tocqueville's Revenge: State, Society, and Economy in Contemporary France*. Cambridge, MA: Harvard University Press.
- . 2005. "Progressive Approaches to Labor Market Activation." Paper presented at the American Political Science Association annual meeting, Washington, DC.
- . 2006a. "Between Neo-Liberalism and No Liberalism: Progressive Approaches to Economic Liberalization in Western Europe." Manuscript, Department of Political Science, University of California, Berkeley, CA.
- , ed. 2006b. *The State after Statism: New State Activities in the Age of Liberalization*. Cambridge, MA: Harvard University Press.
- Lewis, Steven C. 1988. "Unions and Socialism: The CFDT and the Reconstruction of the French Left." Ph.D. Dissertation, Department of Political Science, MIT, Cambridge, MA.
- Lichbach, Mark I., and Paul Almeida. 2002. "Global Order and Local Resistance: The Neoliberal Institutional Trilemma and the Battle of Seattle." Unpublished manuscript, Department of Political Science, University of California-Riverside, February.
- Lijphart, Arend. 1971. "Comparative Politics and the Comparative Method." *American Political Science Review* Vol. 65 (3): 682-93.
- Lipset, Seymour M., and Stein Rokkan. 1990 [1967]. "Cleavage Structures, Party Systems, and Voter Alignments." In P. Mair, ed. *The West European Party System*. Oxford: Oxford University Press.

- Locke, Richard, and Kathleen Thelen. 1995. "Apples and Oranges Revisited: Contextualized Comparisons and the Study of Comparative Labor Politics." *Politics and Society* Vol. 23 (3): 337-367.
- Lozier, Françoise. 1980. "La CFDT en chiffres." *Esprit* No 40: 15-26.
- Magniadas, Jean. 1987. *Le syndicalisme de classe*. Paris: Messidor/Éditions sociales.
- Mahoney, James. 2000. "Path dependence in historical sociology." *Theory and Society* Vol. 29 (4): 507-548.
- Marks, Gary. 1989. *Unions in Politics: Britain, Germany, and the United States in the Nineteenth and Early Twentieth Centuries*. Princeton, NJ: Princeton University Press.
- Marks, Gary, and Carol J. Wilson. 2000. "The Past in the Present: A Cleavage Theory of Party Response to European Integration." *British Journal of Political Science* Vol. 30 (3): 433-59.
- Martin, Andrew, and George Ross. 2001. "Trade Union Organizing at the European Level: The Dilemma of Borrowed Resources." In D. Imig and S. Tarrow, eds. *Contentious Europeans: Protest and Politics in an Emerging Polity*. Lanham, MD: Rowan & Littlefield.
- Maurice, Marc, and François Sellier. 1979. "Societal Analysis of Industrial Relations: A Comparison between France and West Germany." *British Journal of Industrial Relations* Vol. 17 (3): 322-336.
- Mayda, Anna Maria, and Dani Rodrik. 2005. "Why are some people (and countries) more protectionist than others?" *European Economic Review* Vol. 49 (6): 1393-1430.
- McAdam, Doug. 1995. "'Initiator' and 'Spin-off' Movements: Diffusion Processes in Protest Cycles." In M. Traugott, ed. *Repertoires and Cycles of Collective Action*. Durham, NC: Duke University Press.
- . 1999 [1982]. *Political Process and the Development of the Black Insurgency, 1930-1970*. Chicago: University of Chicago Press.
- McAdam, Doug, John D. McCarthy, and Mayer N. Zald, eds. 1996. *Comparative Perspectives on Social Movements*. New York: Cambridge University Press.
- McAdam, Doug, and William H. Sewell, Jr. 2001. "It's About Time: Temporality in the Study of Social Movements and Revolutions." In R. R. Aminzade et al, *Silence and Voice in the Study of Contentious Politics*. New York: Cambridge University Press.
- McAdam, Doug, Sidney Tarrow, and Charles Tilly. 2001. *Dynamics of Contention*. New York: Cambridge University Press.
- McCarthy, John D., and Mayer N. Zald. 1977. "Resource Mobilization and Social Movements: A Partial Theory." *American Journal of Sociology* Vol. 82 (6): 1212-41.

- Meguid, Bonnie M. 2002. *Competition Between Unequals: The Role of Mainstream Party Strategy in Rising Party Success in Western Europe*. Ph.D. Dissertation, Government Department, Harvard University, Cambridge, MA.
- . 2005. "Competition Between Unequals: The Role of Mainstream Party Strategy in Niche Party Success." *American Political Science Review* Vol. 99 (3): 347-359.
- Meunier, Sophie. 2000. "France, Globalization and Global Protectionism." Working Paper Series #71, Center for European Studies, Harvard University.
- . 2005a. "Globalization and Europeanization: A Challenge to French Politics." *French Politics* Vol. 2: 125-150.
- . 2005b. "Anti-Americanisms in France." *French Politics, Culture, and Society* Vol. 23 (2): 125-40.
- Meyer, David S. 2002. "Claiming Credit: The Social Construction of Movement Success." Paper presented at the annual meeting of the American Sociological Association, Washington, DC.
- . 2004. "Protest and Political Opportunities." *Annual Review of Sociology* Vol. 30: 125-45.
- Meyer, David S., and Suzanne Staggenborg. 1996. "Movements, Countermovements, and the Structure of Political Opportunity." *American Journal of Sociology* Vol. 101 (6): 1628-60.
- Michelat, Guy, and Michel Simon. 2004. *Les ouvriers et la politique: Permanence, ruptures, réalignements*. Paris: Presses de Sciences Po.
- Milner, Helen V. 1999. "The Political Economy of International Trade." *Annual Review of Political Science* Vol. 2: 91-114.
- Milner, Helen V., and Benjamin Judkins. 2004. "Partisanship, Trade Policy, and Globalization: Is There a Left-Right Divide on Trade Policy?" *International Studies Quarterly* Vol. 48 (1): 95-119.
- Mintzberg, Henry. 1978. "Patterns in Strategy Formation." *Management Science* Vol. 24 (9): 934-48.
- Mitchell, Kristine Eileen. 2006. *Europeanizing Unions: Trade Union Adaptation to European Integration*. Ph.D. Dissertation, Department of Politics, Princeton University, NJ.
- Moody, Kim. 1988. *An Injury to All: The Decline of American Unionism*. New York: Verso.
- . 1997. *Workers in a Lean World: Unions in the International Economy*. New York: Verso.
- Mouchard, Daniel. 2002. "Les 'sans-emploi.'" In X. Cretiez and I. Sommier, eds. *La France rebelle*. Paris: Michalon.

- Moynot, Jean-Louis. 1982. *Au milieu du gué: CGT, syndicalisme et démocratie de masse*. Paris: Presses Universitaires de France.
- Munck, Ronaldo. 2002. *Globalisation and Labour: The New 'Great Transformation'*. London, UK: Zed Books.
- Nora, Pierre, ed. 1984. *La CFDT en questions*. Paris: Gallimard.
- Notat, Nicole. 1997. *Je voudrais vous dire*. Paris: Seuil.
- O'Brien, Robert, et al. 2000. *Contesting Global Governance: Multilateral Economic Institutions and Global Social Movements*. Cambridge, UK: Cambridge University Press.
- Observatoire de la mondialisation. 1998. *Lumière sur l'AMI: Le test de Dracula*. Paris: L'Esprit frappeur.
- Offe, Claus. 1987. "Challenging the boundaries of institutional politics: social movements since the 1960s." In C. S. Maier, ed., *Changing Boundaries of the Political: Essays on the Evolving Balance Between the State and Society, Public and Private in Europe*. New York: Cambridge University Press.
- Olson, Mancur. 1975. *The Logic of Collective Action: Public Goods and the Theory of Groups*. Cambridge, MA: Harvard University Press.
- Palier, Bruno. 2002. *Gouverner la Sécurité sociale: Les réformes du système français de protection sociale depuis 1945*. Paris: Presses universitaires de France.
- Panbianco, Angelo. 1988. *Political Parties: Organization and Power*. New York: Cambridge University Press.
- Patterson, Molly, and Kristen Renwick Monroe. 1998. "Narrative in Political Science." *Annual Review of Political Science* Vol. 1: 315-31.
- Péchu, Cécile. 1996. "Quand les exclus passent à l'action: La mobilisation des mal-logés." *Politix* No. 34: 114-33.
- . 2002. "Les 'sans-logis'." In X. Crettiez and I. Sommier, eds. *La France rebelle*. Paris: Michalon.
- Pianta, Mario, Federico Silva, and Duccio Zola. 2004. "Global Civil Society Events: Parallel Summits, Social Fora, Global Days of Action." In *Global Civil Society 2004-2005*. Centre for Study of Global Governance and Centre on Civil Society, London School of Economics.
- Pierson, Paul. 2004. *Politics in Time: History, Institutions, and Social Analysis*. Princeton, NJ: Princeton University Press.
- Piketty, Thomas. 2003. "Income Inequality in France, 1901-1998." *Journal of Political Economy* Vol. 111 (5): 1004-1042.
- Piven, Frances Fox, and Richard A. Cloward. 1979 [1977]. *Poor People's Movements: Why They Succeed, How they Fail*. New York: Vintage.

- . 2005. "Rulemaking, Rulebreaking, and Power." In T. Janoski et al, eds. *Handbook of Political Sociology*. New York: Cambridge University Press.
- Podobnik, Bruce. 2004. "Resistance to Globalization: Cycles and Evolutions in the Globalization Protest Movement." Paper presented at the annual meeting of the American Sociological Association, San Francisco, CA.
- Polanyi, Karl. 1957 [1944]. *The Great Transformation*. Boston: Beacon Press.
- Polsky, Andrew. 2000. "When Business Speaks: Political Entrepreneurship, Discourse and Mobilization in American Partisan Regimes." *Journal of Theoretical Politics* Vol. 12 (4): 455-476.
- Polletta, Francesca. 1998. "'It Was Like A Fever...' Narrative and Identity in Social Protest." *Social Problems* Vol. 45 (2): 137-159.
- . 2004. "Culture In and Outside Institutions." *Research in Social Movements, Conflicts and Change* Vol. 25: 161-183.
- Pontusson, Jonas. 1992. "Introduction: Organizational and Political-Economic Perspectives on Union Politics." In M. Golden and J. Pontusson, eds. *Bargaining for Change: Union Politics in North America and Europe*. Ithaca, NY: Cornell University Press.
- . 1995. "Explaining the Decline of European Social Democracy: The Role of Structural Economic Change." *World Politics* Vol. 47 (4): 495-533.
- Pouch, Thierry. 2001. *Les économistes français et le marxisme: Apogée et déclin d'un discours critique (1950-2000)*. Rennes, France: Presses Universitaires de Rennes.
- Powell, Walter. W., and Paul J. DiMaggio, eds. 1991. *The New Institutionalism in Organizational Analysis*. Chicago: University of Chicago Press.
- Raynaud, Philippe. 1999. *Les Nouvelles radicalités*. Paris: Note de la Fondation Saint-Simon.
- Reynaud, Jean-Daniel. 1975. "Trade Unions and Political Parties in France: Some Recent Trends." *Industrial and Labor Relations* Vol. 28 (2): 208-25.
- Rochon, Thomas R. 1998. *Culture Moves: Ideas, Activism, and Changing Values*. Princeton, NJ: Princeton University Press.
- Rodrik, Dani. 1997. *Has Globalization Gone Too Far?* Washington, DC: Institute for International Economics.
- Rogowski, Ronald. 1989. *Commerce and Coalitions: How Trade Affects Domestic Political Alignments*. Princeton, NJ: Princeton University Press.
- Rosanvallon, Pierre. 1980. "L'identité CFDT." *Esprit* No 40: 9-14.
- Ross, George. 1975. "Party and Mass Organization: The Changing Relationship of PCF and CGT." In D. L. Blackmer and S. Tarrow, eds. *Communism in Italy and France*. Princeton, NJ: Princeton University Press.

- . 1979. “The Confédération Générale du Travail in Eurocommunism.” *Politics and Society* Vol. 9 (1): 33-60.
- . 1982. “The Perils of Politics: French Unions and the Crisis of the 1970s.” In P. Lange, G. Ross, and M. Vannicelli, eds. *Unions, Change and Crisis: French and Italian Union Strategy and the Political Economy, 1945-1980*. London, UK: George Allen & Unwin.
- Royall, Frédéric. 2000. “Protestations collectives d’une monorité socio-économique en France.” *French Politics, Culture & Society* Vol. 18 (2): 69-85.
- Ruggie, John Gerard. 1982. “International Regimes, Transactions, and Change: Embedded Liberalism in the Postwar Economic Order.” *International Organization* Vol. 36 (2): 379-415.
- . 2003. “Taking Embedded Liberalism Global: the Corporate Connection.” In D. Held and M. Koenig-Archibugi, eds. *Taming Globalization: Frontiers of Governance*. London: Polity.
- Salem, André. 1993. “De travailleurs à salariés: Repères pour une étude de l’évolution du vocabulaire syndical (1971-1990).” *Mots* No. 36: 74-83.
- Samuels, Richard J. 2003. *Machiavelli’s Children: Leaders and Their Legacies in Italy and Japan*. Ithaca, NY: Cornell University Press.
- Sartori, Giovanni. 1990 [1968]. “The Sociology of Parties: A Critical Review.” In P. Mair, ed. *The West European Party System*. Oxford: Oxford University Press.
- Sassoon, Donald. 1996. *One Hundred Years of Socialism: The West European Left in the Twentieth Century*. New York: The New Press.
- Scheve, Kenneth F., and Matthew J. Slaughter. 2001. *Globalization and the Perception of American Workers*. Washington, DC: Institute for International Economics.
- Scruggs, Lyle, and Peter Lange. 2002. “Where Have All the Members Gone? Globalization, Institutions, and Union Density.” *Journal of Politics* Vol. 64 (1): 126-53.
- Sewell, William H. 1992. “A Theory of Structure: Duality, Agency, and Transformation.” *American Journal of Sociology* Vol. 98 (1): 1-29.
- Shonfield, Andrew. 1965. *Modern Capitalism: The Changing Balance of Public and Private Power*. New York: Oxford University Press.
- Silver, Beverly J. 2003. *Forces of Labor: Workers’ Movements and Globalization since 1870*. New York: Cambridge University Press.
- Skocpol, Theda. 1994. *Social Revolutions in the Modern World*. New York: Cambridge University Press.
- Slaughter, Matthew J. 2007. “Globalization and Declining Unionization in the United States.” *Industrial Relations* Vol. 46 (2): 329-46.

- Smith, Timothy. 2004. *France in Crisis: Welfare, Inequality and Globalization since 1980*. Cambridge, UK: Cambridge University Press.
- Smith, Jackie, Charles Chatfield, and Ron Pagnucco, eds. 1997. *Transnational Social Movements and Global Politics. Solidarity Beyond the State*. Syracuse, NY: Syracuse University Press.
- Smith, Jackie, and Hank Johnston, eds. 2002. *Globalization and Resistance: Transnational Dimensions of Social Movements*. Lanham, MD: Rowman and Littlefield.
- Snow, David A., and Robert D. Benford. 1988. "Ideology, Frame Resonance, and Participant Mobilization." In B. Klandermans, H. Kriesi, and S. Tarrow, eds., *From Structure to Action: Comparing Social Movements across Cultures*. Greenwich, CT: JAI Press.
- . 1992. "Master Frames and Cycles of Protest." In A. D. Morris and C. McClurg Mueller, eds. *Frontiers in Social Movement Theory*. New Haven, CT: Yale University Press.
- Snow, David A. et al. 1986. "Frame Alignment Processes, Micromobilization, and Movement Participation." *American Sociological Review* Vol. 51 (4): 464-81.
- Staggenborg, Suzanne. 1986. "Coalition Work in the Pro-Choice Movement: Organizational and Environmental Opportunities and Obstacles." *Social Problems* Vol. 33 (5): 374-90.
- Stark, David, and Laszlo Bruszt. 1998. *Postsocialist Pathways: Transforming Politics and Property in East central Europe*. New York: Cambridge University Press.
- Steenbergen, Marco R., and Gary Marks. 2004. "Introduction: Models of political conflict in the European Union." In G. Marks and M. R. Steenbergen, eds. *European Integration and Political Conflict*. Cambridge, UK: Cambridge University Press.
- Steinberg, Marc W. 1995. "The Roar of the Crowd: Repertoires of Discourse and Collective Action among the Spitalfields Silk Weavers in Nineteenth-Century London." In M. Traugott, ed. *Repertoires and Cycles of Collective Action*. Durham, NC: Duke University Press.
- . 1998. "Tilting the Frame: Considerations on Collective Action Framing from a Discursive Turn." *Theory and Society* Vol. 27 (6): 845-872.
- Steinmetz, George. 1992. "Reflections of the Role of Social Narratives in Working-Class Formation: Narrative Theory in the Social Sciences." *Social Science History* Vol. 16 (3): 489-516.
- Stone, Deborah A. 1989. "Causal Stories and the Formation of Policy Agendas." *Political Science Quarterly* Vol. 104 (2): 281-300.
- Streeck, Wolfgang, and Anke Hassel. 2003. "Trade unions as political actors." In J. T. Addison and C. Schnabel, eds. *International Handbook of Trade Unions*. Cheltenham, UK: Edward Elgar.

- Streeck, Wolfgang, and Kathleen Thelen. 2005. "Introduction: Institutional Change in Advanced Political Economies." In W. Streeck and K. Thelen, eds. *Beyond Continuity: Institutional Change in Advanced Political Economies*. Oxford: Oxford University Press.
- Swank, Duane. 2002. *Global Capital, Political Institutions, and Policy Change in Developed Welfare States*. New York: Cambridge University Press.
- Swidler, Ann. 1986. "Culture in Action: Symbols and Strategies." *American Sociological Review* Vol. 51 (1): 273-286.
- . 1995. "Cultural Power and Social Movements." In H. Johnston and B. Klandermans, eds. *Social Movements and Culture*. Minneapolis, MN: University of Minnesota Press.
- . 2001. *Talk of Love: How Culture Matters*. Chicago: University of Chicago Press.
- Taggart, Paul. 1998. "A touchstone of dissent. Euroscepticism in contemporary Western European party systems." *European Journal of Political Research* Vol. 33 (3): 363-88.
- Tarrow, Sidney. 1989. *Democracy and Disorder: Protest and Politics in Italy, 1965-1975*. Oxford: Oxford University Press.
- . 1990. "The Phantom of the Opera: Political Parties and Social Movements of the 1960s and 1970s in Italy." In R. J. Dalton and M. Kuechler, eds. *Challenging the Political Order: New Social and Political Movements in Western Democracies*. London: Polity Press.
- . 1992. "Mentalities, Political Culture, and Collective Action Frames: Constructing Meaning Through Action." In A. D. Morris and C. M. Mueller, eds. *Frontiers in Social Movement Theory*. New Haven, CT: Yale University Press.
- . 1996. "States and opportunities: The political structuring of social movements." In D. McAdam, J. D. McCarthy, and M. N. Zald, eds., *Comparative Perspectives on Social Movements*. New York: Cambridge University Press.
- . 1998. *Power in Movement: Social Movements and Contentious Politics* (2nd ed.). New York: Cambridge University Press.
- . 2001. "Transnational Politics: Contention and Institutions in International Politics." *Annual Review of Political Science* Vol. 4: 1-20.
- . 2002. "From Lumping to Splitting: Specifying Globalization and Resistance." In J. Smith and H. Johnston, eds., *Globalization and Resistance: Transnational Dimensions of Social Movements*. Lanham, MD: Rowman and Littlefield.
- . 2005. *The New Transnational Activism*. New York: Cambridge University Press.
- Taylor, Graham, and Andrew Mathers. 2002. "Social Partner or Social Movement? European Integration and Trade Union Renewal in Europe." *Labor Studies Journal* Vol. 27 (1): 93-108.

- Taylor, Verta. 1989. "Social Movement Continuity: The Women's Movement in Abeyance." *American Sociological Review* Vol. 54 (5): 761-75.
- Thelen, Kathleen. 1999. "Historical Institutionalism in Comparative Politics." *Annual Review of Political Science* vol. 2: 369-404.
- . 2003. "How Institutions Evolve: Insights from Comparative Historical Analysis." In J. Mahoney and D. Rueschemeyer, eds. *Comparative Historical Analysis in the Social Sciences*. New York: Cambridge University Press.
- Tilly, Charles. 1978. *From Mobilization to Revolution*. Reading, MA: Addison-Wesley Publishing Company.
- . 1986. *The Contentious French: Four Centuries of Popular Struggle*. Cambridge, MA: Belknap Press of Harvard University Press.
- . 1995. "Contentious Repertoires in Great Britain, 1758-1834." In M. Traugott, ed. *Repertoires and Cycles of Collective Action*. Durham, NC: Duke University Press.
- . 1999. "Epilogue: Now Where?" In G. Steinmetz, ed. *State/Culture: State-Formation after the Cultural Turn*. Ithaca, NY: Cornell University Press.
- Tilly, Charles, and Sidney Tarrow. 2007. *Contentious Politics*. Boulder, CO: Paradigm Publishers.
- Tixier, Pierre Éric. 1992. *Mutation ou déclin du syndicalisme? Le cas de la CFDT*. Paris: Presses universitaires de France.
- Turner, Lowell. 2005. "From Transformation to Revitalization: A New Research Agenda for a Contested Global Economy." *Work and Occupation* Vol. 32 (4): 383-99.
- Uggla, Fredrik. 2006. "Between Globalism and Pragmatism: ATTAC in France, Germany, and Sweden." *Mobilization* Vol. 11 (1): 51-66.
- Van der Waal, Jeroen, Peter Achterberg, and Dick Houtman. 2007. "Class Is Not Dead—It Has Been Buried Alive: Class Voting and Cultural Voting in Postwar Western Societies (1956-1990)." *Politics and Society* Vol. 35 (3): 403-26.
- Van Gyes, Guy, et al, eds. 2001. *Can Class Still Unite? The differentiated work force, class colidarity and trade unions*. Aldershot, UK: Ashgate.
- Vaughan, Diane. 2002. "Signals and Interpretive Work: The Role of Culture in a Theory of Practical Action." In K. A. Cerulo, ed. *Culture in Mind: Toward a Sociology of Culture and Cognition*. New York: Routledge.
- Viannet, Louis. 1995. *Syndicalisme: Les nouveaux défis*. Paris: Éditions de l'atelier/Éditions Ouvrières.
- Visser, Jelle. 2000. "France." In B. Ebbinghaus and J. Visser, eds. *The Societies of Europe: Trade Unions in Western Europe since 1945*. London, UK: Macmillan.
- Voss, Kim, and Rachel Sherman. 2000. "Breaking the Iron Law of Oligarchy: Union Revitalization in the American Labor Movement." *American Journal of Sociology* Vol. 106 (2): 303-49.

- Wallerstein, Michael, and Bruce Western. 2000. "Unions in Decline? What Has Changed and Why?" *Annual Review of Political Science* Vol. 3: 355-77.
- Waters, Sarah. 1998. "New Social Movement Politics in France: The Rise of Civic Forms of Mobilisation." *West European Politics* Vol. 21 (3): 170-186.
- . 2004. "Mobilising against Globalisation: Attac and the French Intellectuals." *West European Politics* Vol. 27 (5): 854-74.
- . 2006. "A l'attac: Globalisation and Ideological Renewal on the French Left." *Modern & Contemporary France* Vol. 14 (2): 141-56.
- Weber, Max. 1946. "The Social Psychology of the World Religions." In *From Max Weber: Essays in Sociology*. Translated, edited, and with an introduction by H. H. Gerth and C. Wright Mills. New York: Oxford University Press.
- Weir, Margaret. 1992. "Ideas and the politics of bounded innovation." In S. Steinmo, K. Thelen, and F. Longstreth, eds. *Structuring Politics: Historical Institutionalism in Comparative Analysis*. New York, NY: Cambridge University Press.
- Western, Bruce. 1997. *Between Class and Market: Postwar Unionization in the Capitalist Democracies*. Princeton, NJ: Princeton University Press.
- Wilson, James Q. 1995 [1974]. *Political Organizations*. Princeton, NJ: Princeton University Press.
- Yashar, Deborah J. 2002. "Globalization and Collective Action: A Review Essay." *Comparative Politics* 34.
- Zald Mayer N., and Roberta Ash. 1966. "Social Movement Organizations: Growth, Decay and Change." *Social Forces* Vol. 44 (3): 327-41.
- Zald Mayer N., and John D. McCarthy. 1980. "Social Movement Industries: Competition and Cooperation among Movement Organizations." *Research in Social Movements, Conflicts and Change* Vol. 3: 1-20.
- Zald Mayer N., Calvin Morrill, and Hayagreeva Rao. 2005. "The Impact of Social Movements on Organizations: Environment and Responses." In G. F. Davis, D. McAdam, W. R. Scott, and M. N. Zald, eds. *Social Movements and Organization Theory*. New York: Cambridge University Press.