

## MIT Open Access Articles

### *An auxiliary capacitor based ultra-fast drive circuit for shear piezoelectric motors*

The MIT Faculty has made this article openly available. **Please share** how this access benefits you. Your story matters.

**Citation:** Chatterjee, Kamalesh et al. "An auxiliary capacitor based ultrafast drive circuit for shear piezoelectric motors." *Review of Scientific Instruments* 80.9 (2009): 095110-5.

**As Published:** <http://dx.doi.org/10.1063/1.3213619>

**Publisher:** American Institute of Physics

**Persistent URL:** <http://hdl.handle.net/1721.1/51721>

**Version:** Author's final manuscript: final author's manuscript post peer review, without publisher's formatting or copy editing

**Terms of use:** Attribution-Noncommercial-Share Alike 3.0 Unported



# An auxiliary capacitor based ultra-fast drive circuit for shear piezoelectric motors

Kamalesh Chatterjee<sup>1\*</sup>, M. C. Boyer<sup>1†</sup>, W. D. Wise<sup>1</sup> & E. W. Hudson<sup>1‡</sup>

<sup>1</sup>*Department of Physics, Massachusetts Institute of Technology, Cambridge, MA 02139, USA.*

\*Present address: Baker Hughes, 2001 Rankin Rd, Houston, TX, 77073

†Present address: Department of Physics, Wellesley College, Wellesley, MA 02481

‡To whom correspondence should be addressed. E-mail: ehudson@mit.edu

## Abstract

Shear piezoelectric motors frequently require large voltage changes on very short time scales. Since piezos behave electrically as capacitors, this requires a drive circuit capable of quickly sourcing or sinking a large amount of current at high voltages. Here we describe a novel circuit design using a high voltage amplifier, MOSFET switching stage, and auxiliary capacitor. This circuit can drive piezoelectric motors at higher speeds and lower costs than conventional methods, with greater flexibility for computer automation. We illustrate its application in a controller for a scanning tunneling microscope coarse approach mechanism, and discuss other possible applications and modifications of this circuit.

## I. Introduction

Piezoelectric motors, capable of nanoscale precision over millimeter ranges of motion, have come into common usage. Although a number of different designs exist<sup>1-11</sup>, many share a common set of motions – a slow ramp, in which the piezo stays firmly attached to the object being moved, and a rapid slip, in which the piezo breaks frictional contact with the object and slides along it. Driving this rapid slip can prove challenging as the piezo, which electrically behaves as a capacitor, needs to be charged or discharged through hundreds of volts in

microsecond time scales, requiring the driver to source or sink high transient currents. Unfortunately, high voltage amplifiers rarely have both the high internal slew rate and high transient output current necessary to provide such charging and discharging currents.

Here we describe a straight-forward solution to this problem: the introduction of an auxiliary capacitor at the output of the amplifier to supply high transient currents and of a switching MOSFET stage to provide the switching speed. We have used this idea to design and build a piezo controller for the coarse approach mechanism (“walker”) for our scanning tunneling microscope (STM) to illustrate one possible use of this circuit. We begin section II by describing the shear piezoelectric STM walker and section III by outlining the requirements of a controller to drive this walker. We then describe the circuit design in section IV, presenting both block and detailed circuit diagrams and experimental waveforms. Finally, in section V we provide a comparison with other typical drive methods and describe the advantages of this scheme.

## **II. STM coarse approach “walker”**

A variety of coarse approach mechanisms have been designed for scanning probe microscopes, initially mechanical<sup>12-15</sup>, and more recently using piezoelectric motors<sup>1-10</sup>. We have chosen to use the Pan design<sup>11</sup> because of its stability and reproducibility of motion. Although this STM coarse approach mechanism has been described elsewhere<sup>11</sup>, including our implementation of it<sup>16</sup>, we provide a schematic overview of the Pan-type walker here (Fig. 1) to highlight the drive requirements. Stacks of shear piezos are glued to a body (cross-hatch, to which the sample is firmly attached) but free to slip along a sapphire prism (which houses the scanner and tip) when rapidly excited. A step begins with all piezos discharged. Each foot is then driven in turn,

slipping along the sapphire prism, which is held fixed by the friction of the other feet. After all feet have been sheared (Fig. 1b) they are simultaneously and slowly discharged, pushing the sapphire prism to a new equilibrium position (Fig. 1c) to complete the step. The sequence portrayed in Fig. 1 is for a forward (upwards) step. Backward motion may be obtained by either reversing the polarity of the drive or, better to prevent any small incidental forward motion during the rapid slip of a backward step, by time reversing the process.

### **III. Requirements of piezo controller and the limitations of conventional circuits**

The waveform we use to drive this motion is shown schematically in Fig. 1d, where each curve represents the voltage applied to one piezo stack, vertically offset for clarity. The most demanding part of the drive is the rapid charging of the piezos needed to force a quick slipping motion without disturbing the prism. A large voltage (we use 250 V for ~250 nm steps at room temperature, 400 V for ~100 nm steps at 4 K) must be slewed on the order of a microsecond in order to achieve quick and sizable slip motion.

Electrically, a piezo is a capacitor, so the rapid excitation process corresponds to a fast charging rate (or, for the time reversed waveform, a fast discharging rate). A common driver circuit generates a waveform in a low voltage circuit and then amplifies it using a high voltage amplifier. Fast charging places two often contradictory demands on the amplifier. First, its slew rate, the rate at which the no load output voltage changes after a step change in the input, must be high. Second, because for capacitive loads charging time is dominated by the time it takes for the maximum output current to charge the capacitor, the transient output current rating of the

amplifier needs to be high. These two requirements, high slew rate and high transient current, are unmet by most available high voltage amplifiers. Worse, because manufacturers' amplifier datasheets specify output current for the case of steady output voltage, not the far lower output current available during voltage transients, amplifiers often perform below expectations.

Because of the inadequacies of commercial high voltage amplifiers for driving piezos in this fashion, discrete component amplifiers have been designed for this purpose<sup>17, 18</sup>. However, since amplifiers by definition are optimized for best performance when constituent transistors are operating in the linear region, their switching performance tends to be poor.

Another commonly used method for driving piezos is the triac-based circuit. Triacs can deliver very high transient currents and have a reasonably fast switching speed. However, they lack the flexibility of the amplified waveform approach, as they are typically tied to the 60 Hz sinusoidal utility voltage waveform and thus lack straight forward frequency and amplitude modification.

#### **IV. An auxiliary capacitor based circuit**

To overcome these problems we have designed and built a flexible drive circuit for piezoelectric-based walkers. The core concept of our circuit, introduction of an auxiliary capacitor at the amplifier output to supply the switching transients, resolves the conflicting requirements of high transient current and high slew rate. This idea could be used in many general purpose piezo drive

applications. Below we describe the operation of the circuit in detail as it was implemented for the shear piezo walker controller used in our STM.

We show in Fig. 2 a schematic circuit diagram. We generate two low voltage signals, an analog “waveform” and digital “trigger,” using a National Instruments NI6731 board. The “waveform” input is amplified by a high voltage amplifier (PA98 from Apex Microtechnology, now Cirrus Logic), which charges an auxiliary capacitor ( $C_a = 200$  nF). Output is controlled by two high voltage power MOSFETs (IRF840s) connected in a half bridge configuration and operated only in a switching mode, thus their representation as simple switches  $S_1$  and  $S_2$ . The switches are complimentary, i.e.  $S_1 = \overline{S_2}$ , so that one of them is always ON but they are never ON simultaneously. When  $S_1$  is ON the piezo is connected to the amplifier output, allowing charge stored in the auxiliary capacitor to quickly transfer to the piezo stacks. When  $S_2$  is ON the piezo is shorted to ground. The MOSFET state is controlled by a high voltage high speed power MOSFET driver with dependent high and low side referenced output channels (IR2111 from International Rectifier), which itself is controlled by the “trigger” input.

A more complete circuit diagram (Fig. 3) details the design of the drive circuit. One issue, the floating source of the upper switch  $S_1$ , deserves some comment. This is achieved using a “bootstrap capacitor,” which charges through a diode (MUR160) to a voltage equal to  $V_{cc}$  (+15V), and maintains this voltage difference even after  $S_2$  is turned OFF and the source of  $S_1$  is floated. It thus provides the high side drive (keeping the gate voltage  $H_o \sim V_B$  above the source voltage  $V_S$ ) without requiring an isolated voltage source. The use of high voltage floating MOSFET drivers is explained in detail elsewhere<sup>19</sup>.

As will be apparent below, while all the piezos can be driven by a single amplified waveform and charged by a single auxiliary capacitor, because each foot needs to slip independently, the output to each piezo needs to be controlled by its own pair of MOSFET switches and driver. These “drive circuits” are all activated by a single trigger input, however each driver’s actual switch trigger is delayed by a different length of time. For our application there are six “feet” (piezo stacks) and hence six drive circuits charged by a single amplifier and auxiliary capacitor.

### ***Waveform for driving a single piezo stack forward***

Using this combination of a single amplified waveform and a series of time delayed triggers, the piezo walker can be flexibly driven forward or backward. Experimental waveforms for the forward motion of Fig. 1 are presented in Fig. 4. After a step rise at  $t_1$  in the “waveform” input, the amplifier output rises to the required voltage by time  $t_2$ . The rise time,  $t_2 - t_1 = 500 \mu\text{s}$  for our application, is determined by the slew rate and transient output current of the amplifier as well as the auxiliary capacitor. Additional time is provided between  $t_2$  and  $t_3$  to ensure voltage stabilization at the desired amplifier output. At this point the amplifier is driving only the auxiliary capacitor – the piezos are grounded through the MOSFET switch.

Turning the “trigger” input high at  $t_3$  results in charging of the first piezo with charge provided by the auxiliary capacitor. The pulsed current rating of a MOSFET is very high (32 A for the IRF840), so the available charging current is limited by external circuit elements and wiring resistance. The turn ON time and rise time are about 50 ns for IRF840 MOSFETs, hence the piezo charging appears instantaneous in the time scale of the plot. A series of time delayed

triggers between  $t_3$  and  $t_4$  cause the remaining piezos to charge sequentially and stay charged (slipped) until at  $t_4$  the “waveform” input and hence amplifier output ramp down to the rest, uncharged, state. By  $t_6$  the walker has completed one forward step, and another may immediately be started. The data of Fig. 4 corresponds to a drive frequency of 500 Hz, but the delays between  $t_2$  and  $t_3$ ,  $t_5$  and  $t_6$  and  $t_6$  and  $t_1$  are not inherent to the circuit operation or parameters and hence may be used to adjust this frequency.

For the reverse motion, we use the time reverse of the forward motion, so that the charging process is slow and simultaneous for all the piezo stacks, but the discharging is quick. The step begins with all triggers being set high, turning ON the switch  $S_1$  for all piezos before the amplifier is ramped. To initiate the fast discharge (slipping action), the time delayed triggers fall sequentially, turning switch  $S_2$  ON, and using the large ( $>100$  A) current sinking ability of the MOSFETs to pull each foot back to its rest position. Just like the charging current, the discharge current is effectively limited by external components and wiring.

### ***The auxiliary capacitor***

The unique ability of this circuit to supply a large ( $>100$  A) current during charging comes from the charge stored in the auxiliary capacitor, which has a capacitance 10 or more times that of the piezo stacks (we use 200 nF for 4.7 nF piezos). During forward motion, charge from the auxiliary capacitor is quickly transferred to the piezo stacks when switch  $S_1$  is turned ON. The high transient current does not come from the amplifier. This eases amplifier selection constraints and reduces costs. The addition of an auxiliary capacitor does slow down the dynamic response of the amplifier – about 40 times in this case – and hence the required



dynamic response, that is, the frequency at which the circuit will be driven, determines the maximum allowable value of the auxiliary capacitor.

The interval between the onset of two consecutive piezo stacks is magnified and presented schematically in Fig. 5a. The rapid charging of a piezo does result in a small drop of the auxiliary capacitor voltage (not to scale) and hence of all piezos already “turned ON.” However, the relatively large capacitance of the auxiliary capacitor ensures that this is a minor effect and has no significant impact on operation. After the drop, the auxiliary capacitor is recharged by an almost constant current from the amplifier. The continuous current rating of the amplifier thus partially dictates the delay between piezo onsets, as the auxiliary capacitor should charge to full voltage between them.

We show this behavior experimentally in Fig. 5b. In order to demonstrate the capability to drive large currents, we have replaced the MOSFETs with higher current rated IRF460s and increased the load from 4.7 nF piezos to 220 nF capacitors with an accompanying change of auxiliary capacitor to 2.2  $\mu\text{F}$ . We record the voltage on the auxiliary capacitor, which drops about 25 V ( $\sim 10\%$ ) as the load is quickly charged. We also record the load voltage, and use an exponential fit to the first 2  $\mu\text{s}$  (inset, at which point the voltages have nearly converged at 225 V) to determine a time constant of  $\sim 0.5 \mu\text{s}$ , indicating an initial charging rate of 450 V/ $\mu\text{s}$ , consistent with an initial current of about 100 A.

## **V. Advantages of the new auxiliary capacitor based circuit**

Compared to previous circuit designs for piezoelectric walkers, this auxiliary capacitor based design has several important advantages in terms of cost, switching speed, flexibility, and ease of computer interface.

The controller is relatively inexpensive, as it shares a single high voltage amplifier for all six drive channels, reducing the cost of this most expensive component by a factor of six. It is also easy to modify due to its modular nature. Adding more channels, for example, simply requires the addition of a drive circuit, with no additional inputs, while changing the load, for example by driving piezos with higher capacitance, typically requires at most an increase of the auxiliary capacitor. Even a change as large as making the circuit bipolar so that voltage levels could swing between positive and negative voltage to generate higher shear displacement only involves modifying the power circuit with four quadrant switches; the control scheme remains the same.

Switching speed in our design is set by the rise time of a single high speed power MOSFET, which is typically faster than the slew rate of amplifiers by orders of magnitude due to their internal composition of many transistors in cascade. Yet by using an off-the-shelf amplifier for the initial waveform amplification we can utilize standard amplifier features such as current limits, shutdown and versatile feedback options, which make the controller more robust.

The use of an amplified waveform also gives us flexibility and computer control, especially relative to traditional triac designs tied to the 60 Hz utility voltage waveform. Computer generated “trigger and “waveform” inputs allow shaping of the ramp-back, for example to a constant acceleration rather than the constant velocity signal we have depicted here, and also

allow frequency control. We typically run at 1 kHz, with no observed reduction in step size from lower step rates, significantly increasing the walking speed.

Beyond its use for driving piezoelectric walkers, the auxiliary capacitor and MOSFET switching stage concept can be used in a wide range of applications where a good linear amplification is desired along with fast switching transient performance. This technology could be used, for example, as a driver for piezoelectric motors in laser modulation, semiconductor growth and etching tools, lithography and micromachining. For applications where the average power output lies within the capabilities of a high voltage amplifier, this design resolves the challenging problem of providing rapid transient currents of tens or even hundreds of Amperes while maintaining waveform flexibility.

## References

- 1 D. W. Pohl, Rev. Sci. Inst. **58**, 54 (1987).
- 2 C. Renner *et al.*, Rev. Sci. Inst. **61**, 965 (1990).
- 3 J. Frohn *et al.*, Rev. Sci. Inst. **60**, 1200 (1989).
- 4 A. Guha, S. Kim, and A. L. de Lozanne, Rev. Sci. Inst. **74**, 4384 (2003).
- 5 N. Agrait, Rev. Sci. Inst. **63**, 263 (1992).
- 6 J. M. MacLeod *et al.*, Rev. Sci. Inst. **74**, 2429 (2003).
- 7 A. K. Gupta, and K. W. Ng, Rev. Sci. Inst. **72**, 3552 (2001).
- 8 B. L. Blackford, and M. H. Jericho, Rev. Sci. Inst. **68**, 133 (1997).
- 9 H. P. Rust *et al.*, Rev. Sci. Inst. **68**, 129 (1997).
- 10 X. Chen, E. R. Frank, and R. J. Hamers, Rev. Sci. Inst. **65**, 3373 (1994).
- 11 S. H. Pan, E. W. Hudson, and J. C. Davis, Rev. Sci. Inst. **70**, 1459 (1999).
- 12 A. P. Fein, J. R. Kirtley, and R. M. Feenstra, Rev. Sci. Inst. **58**, 1806 (1987).
- 13 R. Sonnenfeld *et al.*, App. Phys. Lett. **50**, 1742 (1987).
- 14 J. E. Demuth *et al.*, JVST A **4**, 1320 (1986).
- 15 W. J. Kaiser, and R. C. Jaklevic, Surface Science **181**, 55 (1987).
- 16 W. D. Wise *et al.*, submitted to Review of Scientific Instruments (2009).
- 17 M. S. Colclough, Rev. Sci. Inst. **71**, 4323 (2000).
- 18 H. Muller, Rev. Sci. Inst. **76**, 084701 (2005).
- 19 Intl. Rect. App. Note AN-978, <http://www.irf.com/technical-info/appnotes/an-978.pdf>

**Acknowledgements**

We thank Devin Neal for his help in the construction and initial testing of the circuit. This research was supported in part by a Cottrell Scholarship awarded by the Research Corporation, by the MRSEC Program of the National Science Foundation under award number\_DMR 02-13282 and by the CAREER program of the NSF under award number 0348918.

## Figure Captions

Figure 1 (Color online) (a,b,c) Schematic of one forward (upward) step and (d) the waveforms used to drive this step. Starting from an uncharged position (d1), each foot is individually slipped backward while the others hold the prism still (a). Once they have all slipped (b, d2) they are slowly ramped back (d3) to their rest position, pushing the prism forward (c). Waveforms are offset vertically for clarity (d).

Figure 2 (Color online) Block diagram of the driver circuit. The auxiliary capacitor  $C_a$ , which supplies charge for all output channels, is at the output of the high voltage (HV) amplifier. Multiple drive stages (one of which is shown here) consist of MOSFETs  $S_1$  and  $S_2$ , indicated as ON/OFF switches, and a drive circuit and enable rapid switching of the piezo (capacitive) load between the amplified waveform and ground.

Figure 3 (Color online) Detailed circuit diagram. This parallels the block diagram of Fig. 2 to increase readability.

Figure 4 (Color online) Experimental waveforms for forward motion. The “waveform” input is amplified to create an amplifier output, which drives the auxiliary capacitor. The “trigger” input leads to a series of delayed triggers (we use 10  $\mu$ s spacing), one for each output channel, or foot (one is shown here). This leads to a voltage on each of the piezo loads, one of which is shown here (four of the six are shown schematically in Fig. 1d).

Figure 5 (Color online) Rapid charging of the piezo load. (a) In a closer schematic look at the interval immediately after  $t_3$  in Fig. 4, the auxiliary capacitor voltage drops slightly while charging the piezo load, but both it and the piezo return to the full amplifier voltage before the next output is triggered. (b)

Experimentally, using 220 nF capacitors as replacements for the piezo loads, the same features are observed. Inset shows rapid charging, with 0.5  $\mu$ s time constant exponential fit (line).

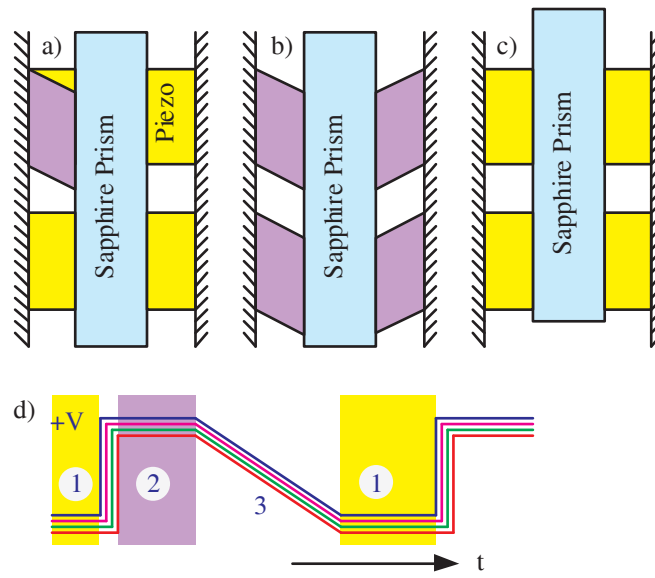

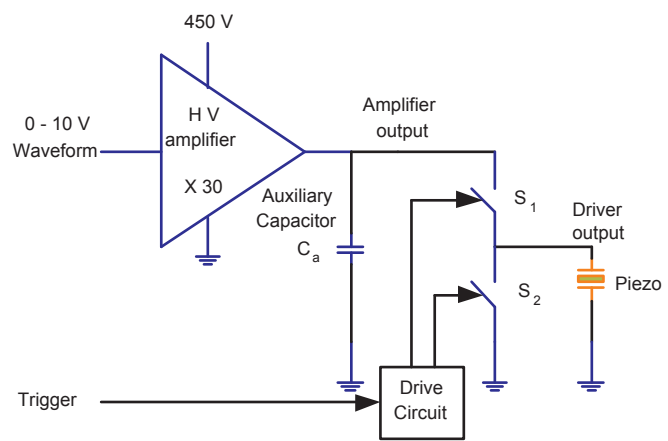

Chatterjee, Figure 2



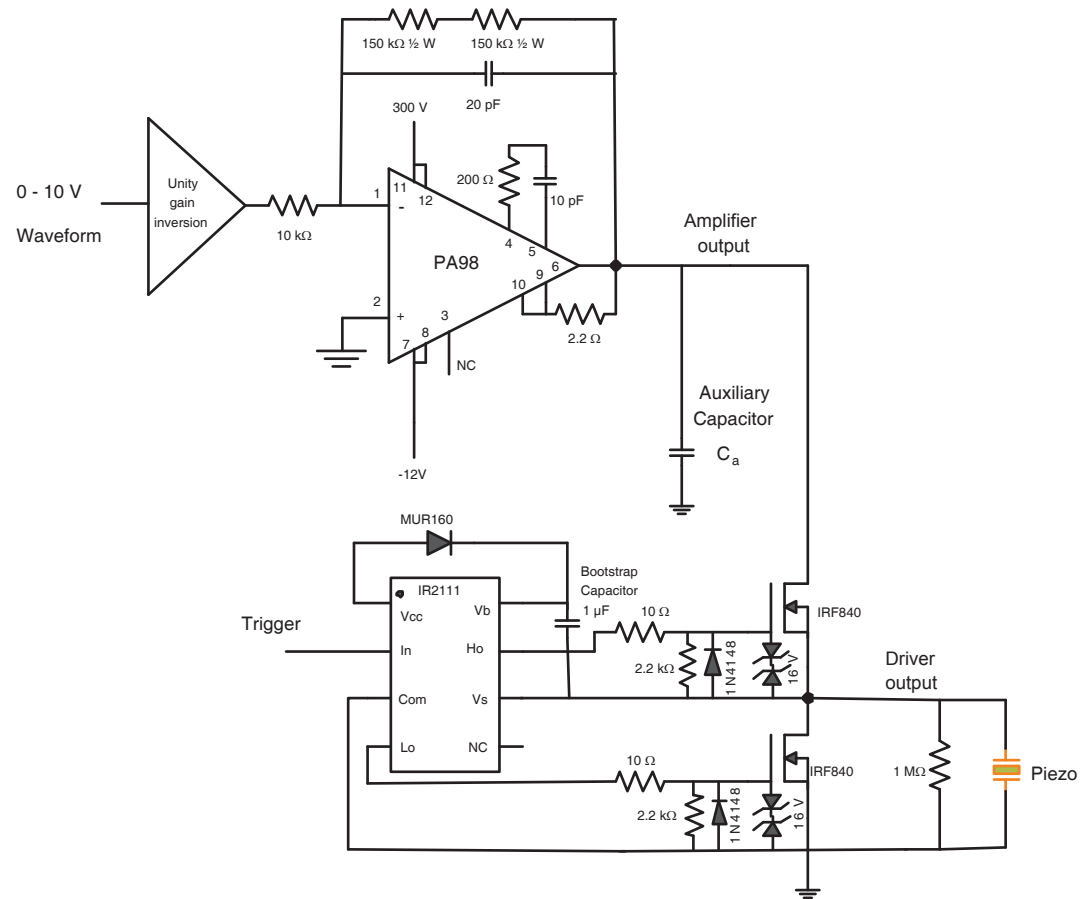

Chatterjee, Figure 3

