

## X. PROCESS ANALYSIS AND SYNTHESIS

Dr. M. V. Cerrillo  
Prof. H. J. Zimmermann

J. J. Jones  
J. A. Raymond

G. Sebestyen  
Rita K. Toebes

### A. A MACHINE THAT CONSTRUCTS PHOTOGRAPHIC REPLICAS OF CODED FIGURES

An initial report on this project was presented in Quarterly Progress Report No. 53, page 111. This report will serve to bring the reader up to date on the project and also expand the points previously raised.

This research is concerned with the design of a machine that will have as its assignment the function of extracting information from a specially prepared motion-picture film of a dance routine and, with the use of this information, of assembling a figure from a stock of cutout parts. The cutout parts will be obtained from a static photograph of the dancer. The figure thus constructed by the machine is to be recorded by a camera. When a sequence of output recordings is assembled, a projection of this sequence can be compared with the original input information. Such a correlation will be used to study experimentally the mathematical operator which produces esthetic quality in the dance routine.

A professional dancer will perform a dance routine that obeys certain constraints. These constraints are planar movements of seven parts of the body in rotation about six prescribed joints. The seven parts are identified by arrows affixed to the dancer. These arrows are actually groups of four colinear spherical frosted lamps. One of each group of four lamps is more intense than the others. This lamp will be used to give the location of the arrow. The three less intense lamps have a twofold purpose. First, with the more intense lamp, they form an axis that defines the angular orientation of the given arrow. Second, they form a binary code that identifies each arrow with the part to which it is affixed.

The dancer with the seven arrows properly coded is supposed to perform a pleasing dance routine. The judge of the degree of the esthetic quality is a skilled dance director, John Gilland, who is in charge of designing the routine, instructing the dancer in its performance, and ascertaining the fact that the dance is pleasing to his esthetic senses. Thus he establishes the initial fidelity criteria.

The dance routine will be recorded by means of a motion-picture camera. The film will be developed so that only the arrows appear. The frames of film thus prepared are to be utilized as the input information to the machine which is the basis of this project. The actual size of the arrows is determined by the spacing of photocells on a sensing device to be described later.

The first function of the machine is the scanning of the input information. The input is scanned in order to extract the information that it contains. A frame of input will be composed of seven groups of points arranged in various locations, angular orientations,

## (X. PROCESS ANALYSIS AND SYNTHESIS)

and sequences. The frame of specially prepared motion-picture film is projected on a frosted glass surface. The scanning process must locate each of the seven intense points. Upon interception, the scanner orients its sensing device to coincide with the arrow direction as defined by an intense point and any of its associated points. At the same time as the orientation is completed, the sensor determines the identity of the arrow from the binary code represented by the three colinear lights. The scanner is composed of three synchro devices that form the two rotations of scanning and single rotation associated with angular alignment of the sensor with the intercepted arrow. The two rotations of scanning take the form of two arrows connected tip-to-tail similar to modulation description. The interception of the most intense point takes place at the tip of the second arrow. The third rotation occurs at the tip of the second arrow.

The sensor is composed of four colinear photocells. The one that is used to detect the interception point is coaxial with the shaft of the synchro that produces the third rotation. The other three photocells sense orientation and identity of the intercepted arrow.

When one of the arrows has been intercepted and identified, the machine must decode the identification information. The binary code for the given part is transformed into a command which controls a turntable. The turntable carries the seven parts about its periphery. The turntable, which is rotating, will stop so that the correct part is offered to the organizing section of the machine when the identification command is received. Each of the parts, which are cut out of a static photograph of the dancer, is prepared so that it can be attracted by a magnetic force. The device that accomplishes the organization is terminated with an electromagnet. When the selected part is placed under the electromagnet by the turntable, the electromagnet is energized and thus picks up the part.

The device that has the task of placing the selected part in the correct position and orientation in the output field is similar to the scanner. It is synchro-connected to the scanner through a relay switching network. One state of the switching network causes the organizer to align itself to a position identical with that of the scanner. The other state of the switching network causes the organizer to align its synchros so that all three effective arrows are colinear. In this position, the end of the organizer, which unlike the scanner is terminated in an electromagnet, is placed directly over the position where the selected parts are offered by the turntable. The figure represented by the input frame of information points is reconstructed by the successive selection and organization of the parts by the machine. Upon completion of the assembly procedure, a photograph is taken of the figure. The figure is then cleared from the output field, the control unit is reset and the input information updated. The procedure is repeated again and again until the input information is exhausted.

The control of the operation of the machine is regulated by a system of switching

## (X. PROCESS ANALYSIS AND SYNTHESIS)

logic. The motors that drive the synchros, the synchro switching relays, the electromagnet, the photocells, the selection turntable, and the process of projection and recording are all governed by the transistorized control network. In addition to the purely manipulative functions, the control logic must decide whether a given arrow has already been intercepted, and, finally, whether or not all seven parts have been organized. The logic also incorporates a conversion matrix for the purpose of decoding the identity of a given intercepted arrow.

The machine is now being constructed. The logical blocks, utilizing approximately one hundred transistors, have been assembled and tested individually. Back-panel wiring is being done at this time. The intricate job of machining and assembly is well underway on the synchro systems for scanning and organization. Each synchro must be connected to the outside through slip rings. The construction of slip rings on the synchros, the interconnecting plates and bearings, of the selection turntable, and of a table to contain the entire machine should soon be completed. The synchromotor transmitter assembly has been constructed.

The services of a professional dancer have been acquired. The training of this dancer is now going on.

A more detailed operational account can be found in the author's S.B. thesis entitled, "A Machine That Constructs Photographic Replicas of Coded Figures," submitted to the Department of Electrical Engineering, M.I.T., May 25, 1959.

J. A. Raymond

## B. ELECTRONIC CURVE TRACING

Electronic curve tracing finds an application in the fields of pattern recognition and identification techniques. A curve-tracing machine such as is described here is used for the purpose of automatically tracing the contour of a simple black and white silhouette. More precisely, a silhouette is defined as an arbitrarily positioned, two-dimensional closed curve, the interior of which is blackened and contains no holes. The desired result of tracing the contour of a curve is the X and Y coordinates as a parametric function of peripheral distance. To obtain these coordinates as a function of time, the curve may be traced with a constant peripheral velocity. Other suitable parameters for uniquely describing the curve can be derived, if required. Fourier-series analysis of the curve is possible if the tracing is carried out in a periodic manner.

In particular, the tracing machine employs a flying-spot scanner with associated optical system and phototube. The silhouette is presented in the form of a transparency on which the light output of the scanner is focused. The light that passes through the transparency is collected on the cathode of a phototube and converted to video information. The heart of the machine is a dual-channel analog servo system which provides

## (X. PROCESS ANALYSIS AND SYNTHESIS)

all of the automatic controls and supplies the X and Y coordinates. A pictorial diagram of the complete system is shown in Fig. X-1.

Since the silhouette is arbitrarily positioned, it must first be located before its contour can be traced. Therefore, two distinct modes of operation are required of the machine, one of searching for the curve and the other, of tracing the curve. The searching mode is instrumented with the use of a spiral sweep that seeks out the silhouette, as shown in Fig. X-2. At the first intersection of the sweep with the boundary of the silhouette, the intensity of the light passing through the transparency drops to a minimum and thus causes an abrupt change in the video signal. A differentiator operating on the output of the phototube then provides a trigger pulse to instruct the machine to hold the coordinates of the point of intersection and to switch to the tracing mode.

The problem of tracing the periphery of the curve can be broken down into two separate operations:

- (a) The scanning spot must be kept centered on the contour of the silhouette.
- (b) The spot must be caused to move along the curve.

Both of these operations can be facilitated by causing the scanning spot to rotate in a circular path and thus describe a circle. The circle size is assumed to be small compared with any important detail in the curve and the speed of rotation of the spot is large as compared with its speed of translation along the curve. Thus the silhouette is pictured as being traced out by a very small circle that moves slowly along its contour. A circle is, of course, easily generated by the addition of sine and cosine waves to the X and Y coordinates. As the scanning spot moving on a circle crosses the boundary of the silhouette into or out of its blackened interior, the video output changes abruptly from a high to a low value, or vice versa. Hence, the derivative of the video waveform provides a timing reference.

Ideally, the circle should be centered on the curve but without a restoring force it would tend to drift away to an uncentered position. As shown in Fig. X-3a, the circle intersects the silhouette as a chord rather than as a diameter. To center the circle on the curve requires that a point halfway between the ends of the chord coincide with the center of the circle. The differences of the X and Y coordinates of these two points are error voltages that could be applied to a zero-position-error servo system to make the points coincide. However, if we think of the circle as a perturbation about its center that is considered as an average value, then the center of the circle can be used as a new origin of coordinates for errors. Therefore, it is sufficient to deal only with the sine and cosine parts of the X and Y voltages. The error coordinates  $x_1$ ,  $y_1$  and  $x_2$ ,  $y_2$  of the ends of the chord are obtained by sampling the sine and cosine waves each time the scanning spot crosses the boundary of the curve. The mean-error coordinates of the chord are then

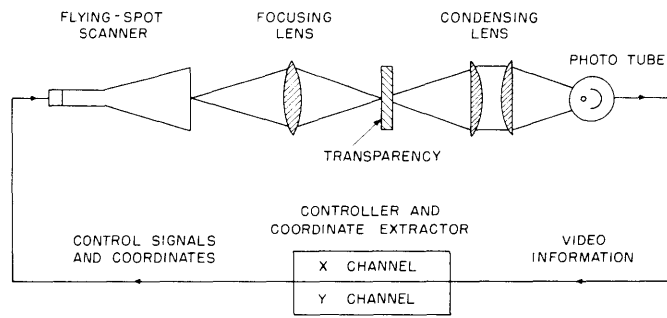

Fig. X-1. Curve-tracing machine.

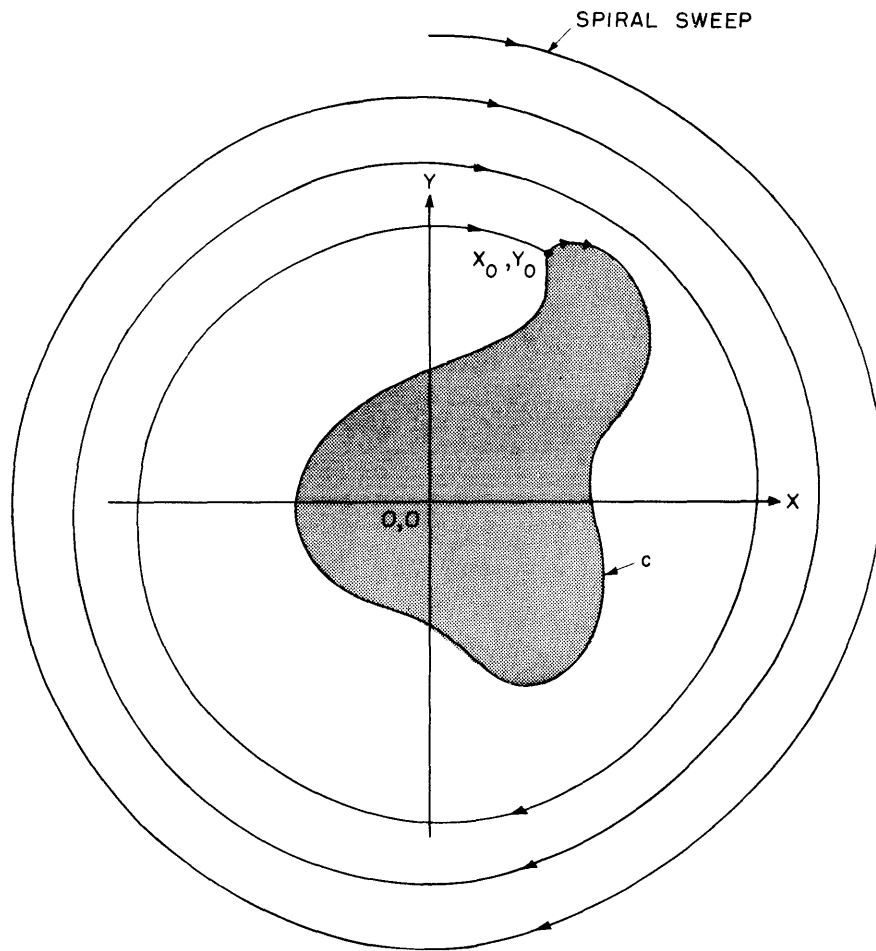

Fig. X-2. Searching for the curve.

(X. PROCESS ANALYSIS AND SYNTHESIS)

$$x_0 = 1/2 (x_1 + x_2)$$

$$y_0 = 1/2 (y_1 + y_2)$$

and the coordinates of the center are 0, 0. Hence,  $x_0$  and  $y_0$  are the total x and y errors, and if they are integrated and added to the coordinates of the center of the circle they will cause the circle to be centered on the curve.

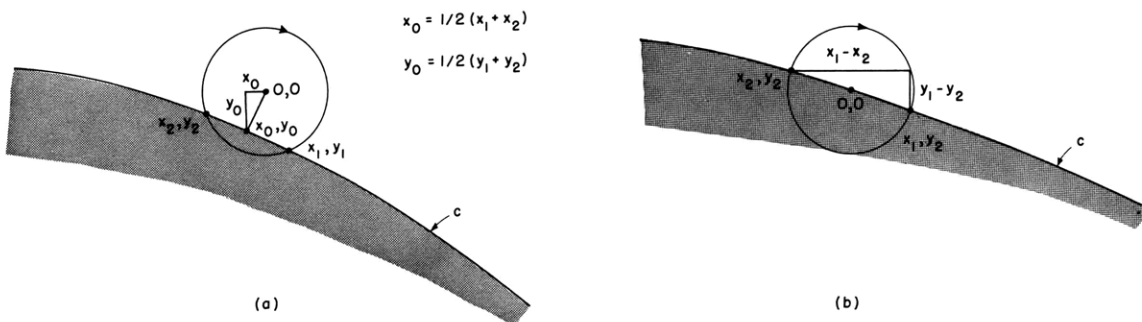

Fig. X-3. Tracing the curve.

If we consider that the circle is already centered on the curve, a diameter of the circle is now tangent to the curve with the point of tangency at the center of the circle, as shown in Fig. X-3b. For a fixed circle diameter, the tangent is a line segment of fixed length, but changing direction, as the circle moves along the contour. Hence, the tangent has all of the characteristics of a velocity vector of a point moving along a curve with constant speed. The x and y components ( $x_1 - x_2$  and  $y_1 - y_2$ ) of this vector always add vectorially to a constant length, and if they are integrated and added to the X and Y voltages they will cause a net translation of the circle in the direction of the tangent vector. Thus the center of the circle moves along the contour of the curve with a constant tangential speed. The total X and Y voltages before the addition of the sine and cosine waves are the coordinates of the center of the circle and of the curve. Hence, the machine has achieved its desired result.

Throughout this discussion it has been tacitly assumed that the circle size, for obvious reasons, is small compared with any important detail of the curve. Furthermore, it has been assumed that the speed of rotation of the spot is large compared with the speed of translation; that is, the circle frequency is much larger than the frequency of tracing around the contour. Because  $x_1, y_1$  and  $x_2, y_2$  occur approximately one-half the period of the circle frequency apart, they cannot be measured simultaneously and therefore a large error could result. However, if the circle frequency is of the order of 1000 times the frequency of tracing, little error should result, in practice.

(X. PROCESS ANALYSIS AND SYNTHESIS)

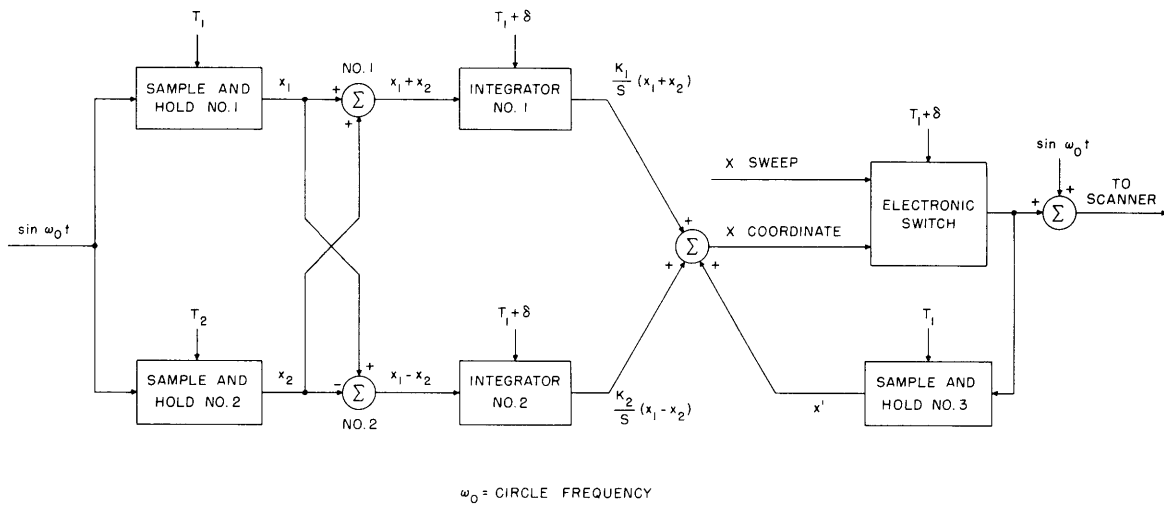

Fig. X-4. The X-channel of the tracing machine.

Fig. X-4 shows a block diagram of the X-channel of the machine. The Y-channel is identical except for the replacement of the sine with a cosine and the X-sweep with the Y-sweep. The following description also applies to the Y-channel. The machine starts its operation in the search mode with the X-sweep feeding through the electronic switch to the flying-spot scanner. Operation continues in this state until the sweep intersects the silhouette, at which time ( $T_1$ ) a trigger pulse occurs. This pulse causes the sample-and-hold circuit No. 3 to hold the value of the X-sweep at the time of intersection, which is the initial X coordinate of the curve. As soon as this operation is completed, the electronic switch is triggered (at time  $T_1 + \delta$ ). The initial X coordinate now feeds through the switch from the sample-and-hold circuit. The machine is now in the tracing mode and the electronic switch remains in its present state. At the instant of intersection, sample-and-hold circuit No. 1 measures the initial value ( $x_1$ ) of the sine wave and the integrators start supplying a correction to the X coordinate. The next time ( $T_2$ ) the scanning spot crosses the curve, sample-and-hold circuit No. 2 measures a new value ( $x_2$ ) of the sine wave and completes the measurement of errors.

The output of the summing circuit No. 1 is now proportional to the mean coordinate of the intersected chord ( $x_0 = 1/2 x_1 + 1/2 x_2$ ) and the output of the summing circuit No. 2 is the length of the x component of this chord. Integrator No. 1 supplies an X correction to center the circle on the curve and integrator No. 2 supplies the X component of the displacement that is necessary to move the circle along the curve with constant speed. These integrators have individual gain controls for adjusting independently the loop gain of the centering servo and the speed of tracing of the curve. The outputs of the integrators are added to the initial X coordinate of the curve to produce a new

(X. PROCESS ANALYSIS AND SYNTHESIS)

corrected X coordinate. When the scanning spot crosses the curve again, sample-and-hold circuit No. 3 measures the new value of the X coordinate. As soon as this operation is completed, the integrators are reset to zero and the cycle of operations is repeated. Resetting the integrators is necessary, since each new output of the sample-and-hold circuit No. 3 contains the past corrections made by the integrators. The discharge of the integrators exactly cancels the discontinuities in the output of the sample-and-hold circuit. Thus the machine traces out the curve.

J. J. Jones