

RADIO PHYSICS

I. MOLECULAR BEAMS*

Prof. J. R. Zacharias	R. S. Badessa	S. G. Kukolich
Prof. J. G. King	V. J. Bates	F. J. O'Brien
Prof. C. L. Searle	R. Golub	R. W. Simon
Prof. K. W. Billman	G. L. Guttrich	C. O. Thornburg, Jr.
	W. D. Johnston, Jr.	

RESEARCH OBJECTIVES

Three kinds of research are pursued in the molecular beams group:

1. High-precision studies of atomic and molecular radiofrequency spectra, an example being the study of the rotational spectrum of HF.

2. The development and intercomparison of atomic frequency standards. The two-cavity ammonia maser and the ammonia molecule decelerator are examples. The CS electric resonance studies mentioned in our "Research Objectives" in Quarterly Progress Report No. 68 (page 25) have been abandoned, because of insufficient signal-to-noise ratio. Work is also being done to determine the system properties of a cesium beam tube, and to develop complementary electronics to realize its latent frequency stability. These new clocks and others of different types will be intercompared by using the computer facilities at M. I. T. in order to check for possible variations in rate with epoch.

3. Experiments that apply parts of these techniques to interesting problems in any area of physics, as in the following list:

- (a) measurement of the velocity of light in terms of atomic standards,
- (b) search for a charge carried by molecules,
- (c) an experiment on an aspect of continuous creation.

These problems are well advanced. In an earlier phase are the following experiments:

- (d) the velocity distribution of He atoms from liquid He,
- (e) experiments with slow electrons (10^{-6} ev).

J. R. Zacharias, J. G. King, C. L. Searle

A. CESIUM BEAM TUBE INVESTIGATION

In Quarterly Progress Report No. 70 (pp. 59-60) it was reported that measurements made on two atomic clocks (incorporating Type 1001 cesium beam tubes) showed that the frequency stability falls far short of the results that might be expected on the basis of the tests of the electronic apparatus described in Quarterly Progress Report No. 69 (pp. 17-21). It was suggested that the instability was caused by a component that would not influence the results of these electronic tests such as faults in the beam tubes themselves or in the modulators used to frequency-modulate the X-band excitation signal. Since plans had already been made to replace the Type 1001 beam tubes by the improved Type 2001, investigation during the past quarter has been confined to a detailed study of the modulators and the errors that they might introduce. The results of this study not only indicate that distortion was being introduced by this particular modulator design, but also showed that a modulator capable of maintaining the low distortion required in this application for long periods of time would be difficult to realize in a practical design.

* This work was supported in part by Purchase Order DDL BB-107 with Lincoln Laboratory, a center for research operated by Massachusetts Institute of Technology, with the support of the U.S. Air Force under Contract AF 19(628)-500.

(I. MOLECULAR BEAMS)

Because square-wave phase modulation can be generated easily with low distortion, we are now studying the properties of systems that have modulation of this type. We have termed it "Frequency Impulse Modulation" to avoid confusion with the square-wave frequency-modulation system that we have been describing in recent quarterly reports. Whereas for square-wave frequency modulation we utilized gating in an attempt to minimize certain undesirable characteristics of the beam-tube transients, the new method of modulation provides a method for removing the basic cause of these undesirable characteristics. In so doing it causes the output frequency of the atomic clock to depend to a greater extent upon the cesium atom itself, thereby achieving accuracy, as well as stability. Specifically, frequency impulse modulation provides a means for detecting the existence of a cavity error θ by observing the beam-tube output while it is in actual operation as a frequency-stabilization device. It therefore permits continuous instrumentation to correct for this error.

The approximate transition probability of a beam tube with separated oscillating fields in the vicinity of resonance is given by

$$P_{p,q} = \sin^2 \frac{2b\ell}{v_n} \cos^2 \frac{(\omega_o - \omega) L}{2v_n}, \quad (1)$$

where ω_o (hereafter called the "true" cesium frequency) is the frequency of the Cs¹³³ hyperfine transition (4,0-3,0) for the magnetic field that is being used, ℓ is the length of each of the microwave exciting cavities, L is the distance between the two cavities, b is proportional to the RF amplitude, and v_n is the particle velocity.

We have assumed in this equation that the oscillating fields in the two cavities are exactly in phase, a condition that in practice is hard to achieve. If the two cavities are out of phase by an angle θ , then the frequency-dependent part of the beam-tube output in the vicinity of resonance can be expressed as

$$V_o = A'(v_n) \cos \left[\frac{(\omega_o - \omega) L}{v_n} + \theta \right] \quad (2)$$

where

$$= A'(v_n) \cos (a+\theta), \quad (3)$$
$$a = \frac{(\omega_o - \omega) L}{v_n}.$$

Note that the quantities a and θ are identical as far as their effect upon the output is concerned. The peak output is not obtained at cesium frequency, but at the frequency for which $a = -\theta$. If we plot the output voltage from Eq. 2 as a function of $(\omega_o - \omega)$, the cosine function would have a period $\Delta\omega = \frac{2\pi v_n}{L}$ and a central peak at a frequency $(\omega_o - \omega) = -\frac{\theta v_n}{L}$. Since these quantities are both functions of particle velocity, summation of a family of these curves to represent the effect of a velocity distribution would be the summation

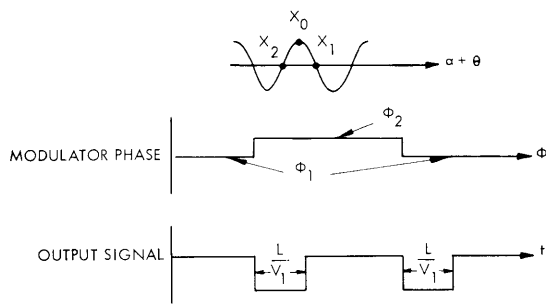

Fig. I-1. Monovelocity (v_1), $(\omega_0 - \omega) = 0$, $\theta = 0$.

If we then apply an abrupt step of phase to the rf excitation, the atoms that had left the first cavity before the phase step, on entering the second cavity, see a phase offset equal to this step. The result will be a sudden drop of the operating point to a lower point on the cosine function, say, to position X_1 (shown for a 90° step). If we maintain this new phase, ϕ_2 , undisturbed, the operating point will remain for a while at position X_1 , then return abruptly to the steady-state position X_0 after all of the atoms that are present between the two cavities at the time of the step have left the interaction space, that is, after an interval L/v_1 . If we then apply a second phase step, thereby returning the radio frequency to its original phase ϕ_1 , the operating point will again drop to a lower point on the cosine function, but this time on the opposite side of the peak. As before, if we maintain this phase undisturbed, the operating point will drop back abruptly to the position on the peak after an interval equal to the transit time between the cavities. This is shown by the waveforms of Fig. I-1. If the phase steps (or frequency impulses) are generated by a square wave, the output waveform will consist of a series of identical rectangular pulses occurring at twice the rate of the modulation. Hence no odd harmonics of the modulating rate would exist.

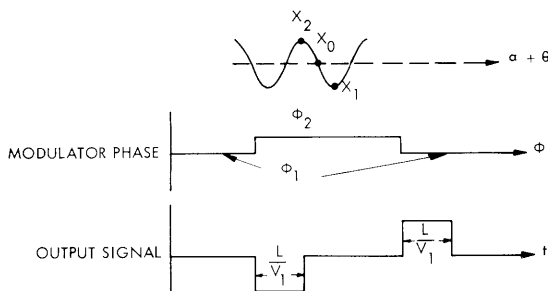

Fig. I-2. Monovelocity (v_1), $(\omega_0 - \omega) = \frac{\pi}{2} \frac{v_1}{L}$, $\theta = 0$.

of a group of cosine functions that differ both in period and position. The result is the familiar Ramsey pattern that, for $\theta = 0$, would be symmetrical about the cesium frequency $(\omega_0 - \omega) = 0$.

Let us first consider the case of a monovelocity beam with rf excitation at the cesium frequency and no cavity phase error (that is, $\alpha=0$, $\theta=0$). The operating point will be at the exact peak of the cosine function as shown by position X_0 in Fig. I-1.

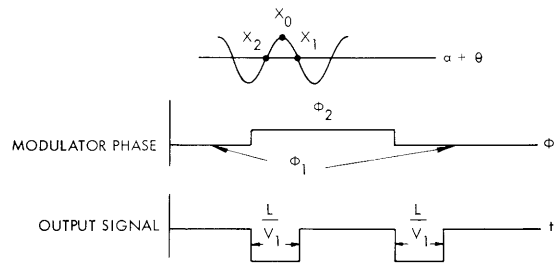

Fig. I-3. Monovelocity (v_1), $(\omega_0 - \omega) = -\theta \frac{v_1}{L}$, $\theta \neq 0$.

(I. MOLECULAR BEAMS)

If the rf excitation frequency is now changed so that $(\omega_o - \omega) = \frac{\pi v_1}{2L}$, the output waveform will consist of a series of alternating negative and positive rectangular pulses as shown in Fig. I-2. Such a waveform contains odd harmonics of the modulating signal (including a strong fundamental) which could be used as a control quantity by passing the output signal through a synchronous detector. If we had chosen to operate at a frequency located

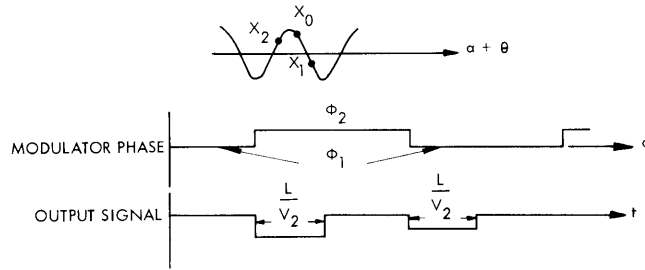

Fig. I-4. Monovelocity (v_2), $(\omega_o - \omega) = -\theta \frac{v_1}{L}$, $\theta \neq 0$.

on the other side of cesium resonance, the output waveform would be the exact negative of the one shown and thus would also provide sense information.

Next, let us assume that there is a cavity tuning error θ , and that the frequency of the rf excitation is such that $(\omega_o - \omega) = -\frac{\theta v_1}{L}$, that is, $\alpha = -\theta$. Under these conditions, the steady-state operating point is again at the exact peak of the cosine function, as shown in Fig. I-3. Square-wave phase modulation produces here an output waveform that is

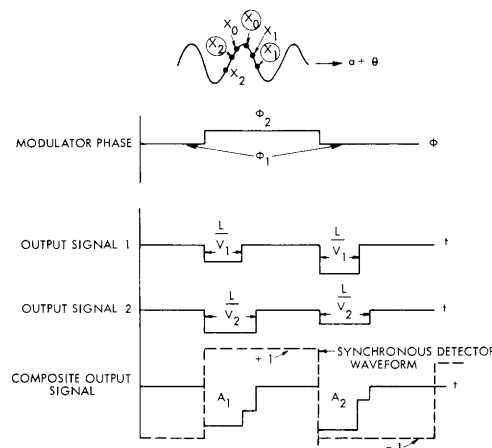

Fig. I-5. Dual velocity, $-\frac{\theta v_1}{L} < (\omega_o - \omega) < \frac{\theta v_2}{L}$, $\theta \neq 0$.

free of odd harmonics of the modulating frequency, and hence, in the absence of knowledge regarding the existence of cavity error, would give the erroneous information that the excitation was at cesium frequency.

If, however, we assume a different velocity, v_2 , but maintain the same rf excitation frequency $(\omega_o - \omega) = -\frac{\theta v_1}{L}$, then the operating point will fall to one side of the peak as shown in Fig. I-4. It is obvious that odd harmonics of the modulating rate exist in the output waveform. Thus a frequency-stabilization loop would call for correction of the rf excitation frequency.

If the beam tube has particles of both v_1 and v_2 , then the loop must find some compromise condition, for example, such as the one illustrated in Fig. I-5, in which the operating points corresponding to v_2 have been circled for clarity. The condition of lock requires that the operating points be placed so that the corresponding output waveform gives zero average voltage when applied to the loop synchronous detector. If the synchronous detector reference is positioned as shown by the dotted line in Fig. I-5, this imposes the condition that area $A_1 = \text{area } A_2$. By geometrical procedures, it can be shown that stabilization for the case illustrated in Fig. I-5 will occur at the frequency $(\omega_o - \omega)$ which satisfies the relationship

$$\frac{1}{v_1} \sin \left[(\omega_o - \omega) \frac{L}{v_1} + \theta \right] + \frac{1}{v_2} \sin \left[(\omega_o - \omega) \frac{L}{v_2} + \theta \right] = 0. \quad (4)$$

By inspection, it is seen that $(\omega_o - \omega)$ must lie between $-\frac{\theta v_1}{L}$ and $-\frac{\theta v_2}{L}$. Thus the cavity error θ will still cause an inaccuracy to exist. If we extend the analysis to the general case of n velocities, in which the relative density of particles of velocity v_n is denoted D_n , we obtain

$$\sum \frac{D_n}{v_n} \sin \left[(\omega_o - \omega) \frac{L}{v_n} + \theta \right] = 0. \quad (5)$$

Notice that no term involving the size of the phase step is present in this expression; thus it appears that frequency impulse modulation causes the frequency of lock to be independent of modulation level.

Of special interest in Fig. I-5 is the fact that the part of the output waveform associated with the positive phase step is not identical in shape to that part associated with the negative step. This indicates that odd harmonics are still present, even though the condition area $A_1 = \text{area } A_2$ causes an average voltage of zero to occur at the output of the synchronous detector. Thus as we tune the rf excitation through resonance, the odd harmonics will reach a minimum at some frequency, but will not go to zero as long as there is a cavity error θ . The synchronous detector output voltage, on the other hand, will go through zero whenever the areas enclosed by its positive and negative half-periods are equal.

(I. MOLECULAR BEAMS)

The consequences of having odd harmonics in the output waveform that merely go through a minimum as a function of the rf excitation frequency are twofold. First, it causes the position of lock of the loop to become dependent upon the phase of the synchronous detector reference. This is evident from Fig. I-5, for, since A_1 and A_2 have different shapes, a choice of synchronous detector reference slightly to the right of the one shown would cause somewhat different areas to be enclosed, and would make the loop call for correction. Second, the existence of these residual odd harmonics gives

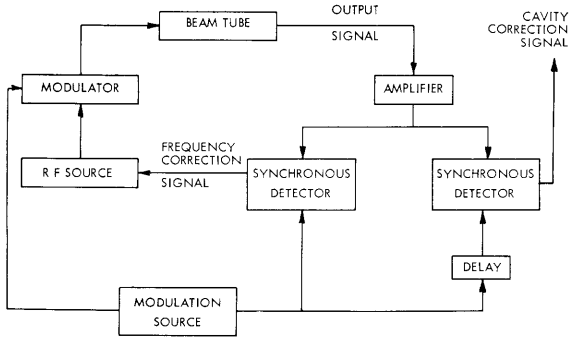
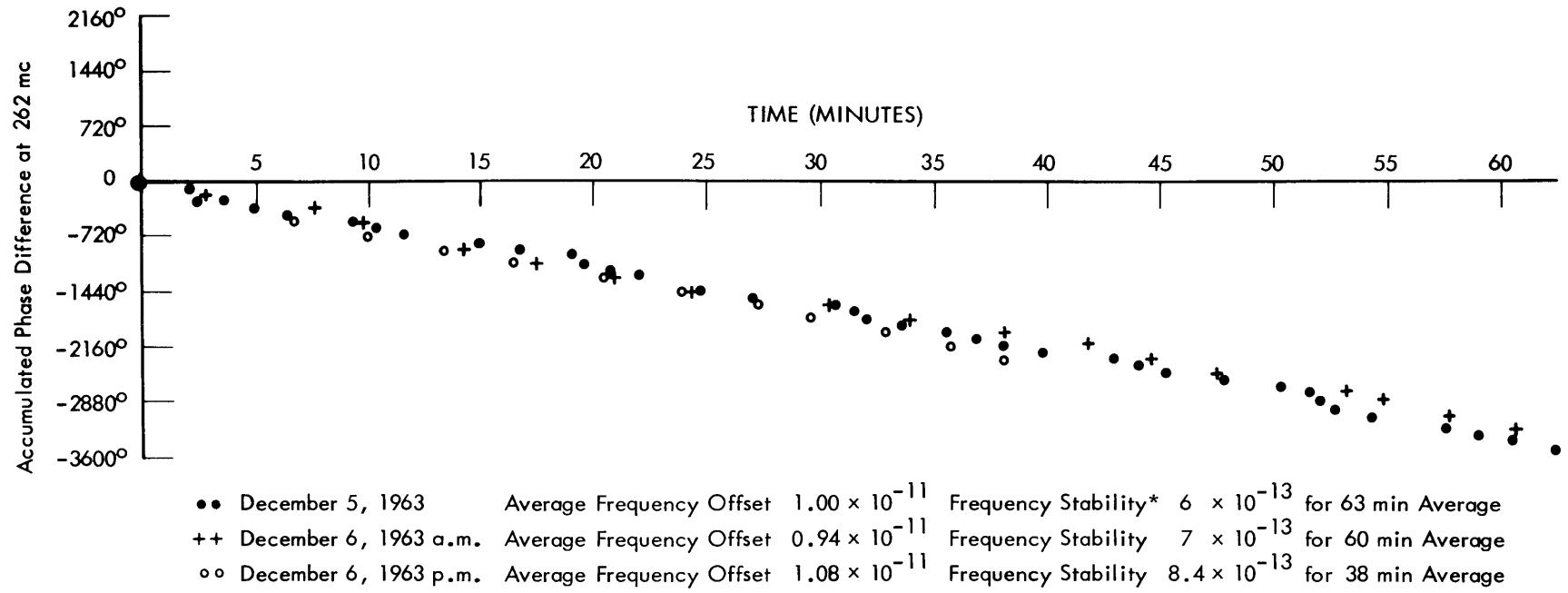

Fig. I-6. Double-loop servo system for locking to true cesium frequency.

valuable evidence that the cavity is, indeed, out of adjustment, and permits us to take measures to correct it, thereby eliminating both the dependence of lock upon the position of the synchronous detector reference and the error caused by having a detuned cavity. A double-loop system for accomplishing this might take the form shown in Fig. I-6. One loop is used for tuning the rf excitation and is essentially the conventional loop used for frequency stabilization. Its synchronous detector reference could be in phase with the modulating signal. The second loop is used for trimming the phase of the cavities and has a synchronous detector reference delayed somewhat from the first. Some interaction between the two loops will occur, but the final point of stabilization will be at a frequency and a cavity tuning for which the average voltage from both synchronous detectors is zero. This, however, can only occur when successive half-periods of the output waveform are identical, a condition that occurs only at cesium frequency with perfectly tuned cavities.

What we have said regarding the undesirability of residual odd harmonics is true for all stabilization loops, regardless of the type of modulation used. In sinusoidal modulation (for which the effect is termed "quadrature"), as well as in other types, it is characterized by output waveforms with minute differences of shape between successive half-periods. In the past the cause of this difference has often been the distortion in the waveform of the phase modulation of the rf excitation, a distortion that might be so low that it defies direct measurement and still be significant enough to completely override the contribution caused by moderate cavity detuning. Since the waveforms used in



$$* \text{Frequency Stability} = \frac{\text{Peak to Peak Phase Deviation from Average Frequency Offset}}{360^\circ \times \text{Measurement Frequency} \times \text{Averaging Time}}$$

Fig. I-7. Preliminary measurements made on the cesium clocks by using the double-loop system.

(I. MOLECULAR BEAMS)

frequency impulse modulation are of a type that are easily obtainable to meet virtually any distortion specification (the phase modulator, for example, operates at essentially two discrete points on its characteristic), the presence of any "quadrature" effect can safely be assumed to result from the action of the beam tube itself.

The most significant advantages of frequency impulse modulation will now be summarized.

1. Frequency impulse modulation produces waveforms that are conducive to extremely low modulation distortion. This permits using the presence of residual odd harmonics as a guide for correcting cavity phase error and achieving lock to the true cesium frequency.

2. The stabilization frequency of a loop with frequency impulse modulation is independent of modulation level, even when the presence of uncorrected cavity error produces a Ramsey pattern that is unsymmetrical.

3. Since frequency impulse modulation derives all of its information from observation of the effect of applying phase steps to the RF excitation, the period of repetition of these steps need be no longer than that required to accommodate the resultant transients. This tends to yield high permissible modulation rates, which is a desirable feature from a practical standpoint, particularly when long beam tubes are used.

Two atomic clocks incorporating Type 2001 cesium beam tubes have been assembled with control loops for which frequency impulse modulation is used. Since no provision exists in these beam tubes for electronic correction of cavity tuning, a system of waveform correction has been devised which is based on the principles outlined above and has been incorporated in a control loop to serve as a temporary substitute for the cavity correction loop. The measurements that we have made are preliminary, but they seem to confirm the desirability of this type of modulation.

Examination of the data presented in Fig. I-7 shows a frequency stability somewhat better than one part in 10^{12} for averaging times of approximately one hour. The first test was made during one afternoon. After its completion, the clocks were shut down until the following morning when they were restarted for the second test. The third test was taken approximately 24 hours after the first. Care was taken to reset the C field currents to the same level for each test, but an improved method for setting these fields is under consideration for future measurements.

R. S. Badessa, V. J. Bates, C. L. Searle

B. AMMONIA MASER WITH SEPARATED OSCILLATING FIELDS

The 3-2 inversion transition in ammonia was observed by means of a molecular beam maser with two microwave cavities separated by 36 cm. The resulting resonance shows the typical Ramsey¹ shape with several peaks, the width of these peaks being determined by the separation of the microwave cavities.

This device is similar to the original ammonia maser² in physical construction but differs in that this device does not oscillate spontaneously and the linewidth is much narrower, since it depends on the separation of the microwave cavities. Using separated cavities has the additional feature of greatly reducing Doppler effects that would be encountered with a single long cavity. The two-cavity maser is shown in Fig. I-8.

Microwave power is injected into the first cavity, and a microwave receiver is connected to the second cavity. Both cavities have open ends to that some of the microwave power from the first cavity is coupled into the second cavity. The conditions are similar to those described by Ramsey¹ for resonance with separated oscillating fields, except that here the transition probability is not measured by deflection of the beam but by observing the additional power delivered to the microwave receiver by the ammonia molecules.

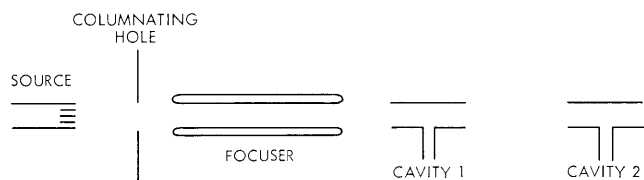

Fig. I-8. The maser.

Feynman³ has shown that any ensemble of two level noninteracting systems may be described by the equations of motion of the magnetic moment of a spin $\frac{1}{2}$ particle in a magnetic field. This allows us to use the analysis of the magnetic case by Ramsey¹ to describe the interaction of the ammonia beam with the RF fields. For the ammonia beam the only physical axis in the representation given above is the axis along which the beam passes, since the oscillating electric field is in this direction.

If we use this description we see that the RF field in the first cavity produces an effect that is analogous to rotating the moment by $\pi/2$ about the RF field direction in magnetic resonance. That is, the transition probability in the first cavity is nearly $1/2$, and the beam has a coherent oscillating electric polarization as it leaves the first cavity. In the space between the cavities the RF field is very small (the Q of the cavities is 1200), so that this polarization oscillates unperturbed at the ammonia inversion frequency. If the frequency of the fields in both cavities resulting from the injected signal is very near the inversion frequency, the oscillating polarization in the beam and the field in the second cavity will be in phase as the beam passes through the second cavity. Consequently, the field in the second cavity will increase the total transition probability and hence also increase the power level in the second cavity, which is coupled to the microwave receiver.

If the frequency of the RF fields in the cavities is slightly off the ammonia frequency, the oscillating polarization in the beam will become progressively farther out of phase with the RF power injected into the cavities as the beam passes from the first cavity to the second. If this phase difference becomes $\pm\pi$, the RF field in the second cavity will

(I. MOLECULAR BEAMS)

reduce the total transition probability and thus the beam will absorb power from the second cavity. This condition will produce the first minima on either side of the main resonance peak.

If the beam velocity is v and the cavity separation is L , the accumulated phase difference will be π when $\Delta\omega = \frac{\pi}{T} = \frac{\pi v}{L}$ or when $\Delta f = \frac{1}{2} \frac{v}{L}$. If the effects of the beam velocity distribution are properly taken into account, then $\Delta f \cong 0.6 \frac{v}{L}$ and other maxima are reduced with respect to the main peak.¹

We may also note from this description that if the RF field in the second cavity is phase-shifted by π with respect to the rf field in the first cavity, this will appear as a frequency error of approximately Δf_o , the linewidth of the molecular resonance. Thus $\frac{\delta f}{\Delta f_o} = \frac{\delta\phi}{\pi}$.

One way of obtaining a phase shift $\delta\phi$ is to detune the second cavity. Near the center of the cavity resonance this shift is $\frac{2\delta\phi}{\pi} = \frac{\delta f_c}{\Delta f_c}$, where δf_c is the cavity detuning, and Δf_c the width of the cavity resonance. Thus the shift of the observed resonance resulting from cavity detuning is $\frac{\delta f}{\Delta f_o} = \frac{\delta\phi}{\pi} = \frac{\delta f_c}{\Delta f_c}$. This effect is similar to the "cavity-pulling" formula for a single-cavity maser⁴ and also occurs in a conventional Ramsey molecular beam apparatus.

In a thorough analysis of a two-cavity maser Basov and Oraevskii⁵ have also suggested that this experiment would be possible.

In our experiment the beam is produced by a crinkle-foil source. A four-pole electric field, 22 cm long, focuses the upper-state molecules into the cavities. The upper inversion-state molecules then pass through two TM_{010} mode microwave cavities 10 cm long and separated by 36 cm. The frequency of the stimulating signal injected into the first cavity is varied, and the power delivered by the second cavity to the microwave receiver as a function of frequency is measured. The injected signal is frequency modulated at 165 cps, and a phase-sensitive detector is used to obtain the first

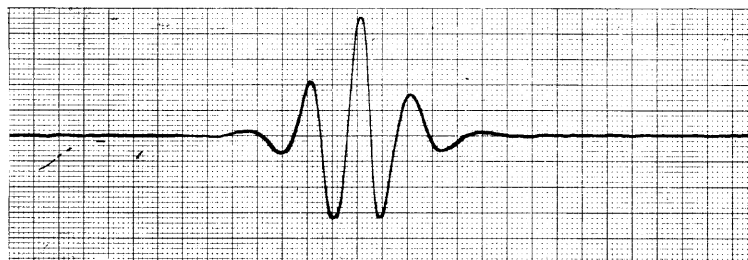

Fig. I-9. Derivative of Ramsey resonance pattern with $\pi/2$ phase shift between the rf fields in the cavities.

derivative of the resonance. The first derivative of the resonance for $\pi/2$ phase difference between the cavities is shown in Fig. I-9.

The observed linewidth is approximately 1 kc, and the resonance pattern is the typical Ramsey curve. In a preliminary experiment the frequency of the ammonia 3-2 inversion line was measured with respect to a National 1001 cesium clock. The measured frequency is $22,834,184,850 \pm 100$ cps. This is in agreement with 22,834.18 mc obtained by Shimoda and Kondo.⁶ In this frequency measurement the output voltage from the phase-sensitive detector was used as the error signal in a servo loop to control the frequency of the microwave power injected into the first cavity. The resetability from one day to the next was a few parts in 10^9 . The principal source of this inaccuracy is believed to be variations of the cavity temperatures, which are not yet sufficiently well stabilized. Since the present cavities are silver, the variations in thermal tuning could be sufficient to account for these deviations. The focuser voltage on this device was changed from 12 kv to 24 kv and the frequency of the resonance changed by less than one part in 10^8 .

Since for larger cavity separation this device may have a very narrow linewidth, it should be possible to construct a molecular resonance clock of useful stability.

S. G. Kukolich

References

1. N. F. Ramsey, Molecular Beams (Oxford University Press, London, 1956), Chap. 5.
2. J. P. Gordon, H. J. Zeiger, and C. H. Townes, *Phys. Rev.* 99, 1264 (1955).
3. R. P. Feynman, F. L. Vernon, and R. W. Hellwarth, *J. Appl. Phys.* 28, 49 (1957).
4. K. Shimoda, T. C. Wang, and C. H. Townes, *Phys. Rev.* 102, 1308 (1956).
5. N. G. Basov and A. N. Oraevskii, *Soviet Phys. - JETP* 15, 1062 (1962).
6. K. Shimoda and K. Kondo, *J. Phys. Soc. Japan* 15, 1125 (1960).

