

Integrating Regional Strategic Transportation Planning and Supply Chain Management: Along the Path to Sustainability

By

Sgouris P. Sgouridis

Diploma in Civil and Environmental Engineering
Aristotle University of Thessalonica, Greece 1999

Submitted to the Engineering Systems Division in Partial Fulfillment of the
Requirements for the Degrees of

Master of Science in Technology and Policy, and
Master of Science in Transportation

at the
Massachusetts Institute of Technology
June 2005

© 2005 Massachusetts Institute of Technology
All Rights Reserved

Signature of Author

.....

Sgouris Sgouridis
February, 2005

Certified by

Joseph M. Sussman
JR East Professor, Civil and Environmental Engineering and Engineering Systems
Thesis Supervisor

Accepted by

Dava Newman
Director, Technology and Policy Program

Accepted by

Andrew Whittle CEE, and Richard de Neufville ESD
Chairman, Departmental Committee on Graduate Studies

Dedication

To my parents

Regional Strategic Transportation Planning and Supply Chain Management Integration: Along the Path to Sustainability

By
Sgouris P. Sgouridis

Submitted to the Engineering Systems Division on February, 14 2005 in Partial Fulfillment of the Requirements for the Degree of Master of Science in Technology and Policy and for the Degree of Master of Science in Transportation

Abstract

A systems perspective for regional strategic transportation planning (RSTP) for freight movements involves an understanding of Supply Chain Management (SCM). This thesis argues that private sector freight shippers and carriers do not simply need capacity improvements from the regional transportation system, but also a subtle understanding by public sector planners of their supply chain needs. The private and the public sector have different agendas and planning horizons but at the same time may have common interests in the region that involve economic robustness, environmental health, and social cohesiveness – what is known as sustainability. We investigate how the largely public sector RSTP and private-sector SCM relate and suggest architectures for an integrated RSTP/SCM planning process.

Thesis Supervisor: Joseph M. Sussman

Title: JR East Professor, Civil and Environmental Engineering and Engineering Systems

Acknowledgements

I need to gratefully acknowledge the valuable suggestions, motivation, support and editing provided by Prof. Joseph Sussman, my thesis supervisor. Secondly, I would like to thank my office mates Travis Dunn, Jeff Ensor, Bernardo Ortiz, and Janine Waliszewski with whom I exchanged valuable discussions, random facts and the occasional joke. Professor Tsamboulas of the Metsovio Polytechnic School, Athens Greece, provided information about freight-related planning in Europe. Funding support came from Motorola and the Onassis Foundation.

Table of Contents

Abstract.....	5
Acknowledgements.....	6
Table of Contents.....	7
List of Tables and Boxes	9
List of Figures.....	10
List of Acronyms	11
1 Introduction.....	13
1.1 Problem Statement	13
1.2 System Overview	15
1.3 Methodological Approach and Engineering Systems Background.....	17
1.4 Purpose and Objectives	21
1.5 Thesis Outline.....	22
PART 1	System Description..... 23
2 Supply Chain Management Basics: background, goals, methods.....	25
2.1 SCM basic definitions	25
2.2 The basics of contemporary SCM practices	26
2.3 SCM Design and Implications	31
2.3.1 SCM design parameters.....	31
2.3.2 SCM Discussion: Issues, Trends, and Implications.....	33
2.4 Missing pieces in the SCM puzzle: a sustainability perspective	34
2.5 SCM Design Overview	35
3 Regional Strategic Transportation Planning	37
3.1 Definitions.....	37
3.2 Framing Transportation Planning.....	38
3.2.1 Discussing the policy goals	39
3.2.2 Policies that influence supply chains and freight flows.....	42
3.3 Methods and Frameworks for RSTP; State-of-the-Art.....	43
3.3.1 Transportation Planning in the U.S.	43
3.3.2 Transportation Planning in Europe.....	44
3.3.3 Transportation Planning Frameworks: evolution in the MIT Perspective.....	45
4 Interconnections between Supply Chain Management Practices and Regional Strategic Transportation Planning in the Existing Literature and Practice	47
4.1 SCM Influence on Regional Development (Theoretical Discussion)	47
4.1.1 Regional Economic Development	47
4.1.2 The private sector perspective: competitive positioning in the global and regional markets	49
4.1.3 Regional Economic Development and SCM: an ambivalent relationship.....	50
4.2 Importance of Freight Transport for the Region (Practical Discussion)	53
4.3 Experiences in Integrated Policies for the Transport of Freight.....	54
4.3.1 Freight Related Transport Policy Reports and Recommendations	54

4.4	Overview	60
Part 2	System Analysis	61
5	Regional Strategic Transportation Planning as a CLIOS.....	63
5.1	Transportation Planning: A Review	63
5.2	Shortcomings in Contemporary Transportation Planning	63
5.3	RSTP as CLIOS.....	65
5.3.1	Representation Phase of CLIOS Process (Steps 1-5)	65
5.3.2	Design, Evaluation and Selection Stage of CLIOS Process (Steps 6-9).....	70
5.3.3	Implementation Stage of CLIOS Process (Steps 10-12).....	74
5.3.4	Overview of the proposed RSTP as CLIOS Approach.....	74
6	Creating an SCM-informed Transportation Planning Process: Decomposition of Freight Transport Planning based on CLIOS.....	77
6.1	Classification of Regional Freight Flows	77
6.2	Region A: One region, one product model.....	79
6.2.1	Representation Phase of the CLIOS Analysis for Region A	80
6.2.2	Design, Evaluation & Selection Phase of the CLIOS Analysis for Region A...	106
6.3	Conclusions on the Proposed RSTP/SCM Process	112
Part 3	System Integration.....	115
7	Integration and Policy Recommendations.....	117
7.1	Identified Shortcomings of Current Regional Freight Transportation Planning	117
7.2	How applicable is the Proposed Framework? Advantages, Disadvantages and Barriers in Application	118
7.3	Proposed Policies and Applications (Policy Recommendations) for review	120
7.3.1	Sustainability Adjusted Freight/Environment Rates (SAFER).....	121
7.4	Overview, Further Research and Concluding Comments	122
	References.....	125
	Appendix I: Glossary of Key CLIOS Terms	133

List of Tables and Boxes

Table 1-1 Summary of Similarities and Differences	17
Table 2-1 SCM Planning Parameters Overview ²⁶	36
Table 2-2 Schematic Influence of Competitive Strategy of Firms and Supply Chain Decisions (Source: Byrnes (21)– adapted by author)	36
Table 4-1 Classification of EU Research Projects on Freight Transport (Source: Schäffeler (54))	58
Table 6-1 Goal Identification for Region A.....	81
Table 6-2 Indicative Issue Checklist for Region A.....	81
Table 6-3 Link Matrix for the CLIOS Analysis of Model A	88
Table 6-4 Weighted Link Matrix for Model A	91
Table 6-5 A Possible Clustering of the Link Matrix for Model A.....	92
Table 6-6 Ranking of Components by Outgoing and Incoming Links.....	93
Table 6-7 Comparative Summary of proposed CLIOS methods of analysis: CLIOS Diagrams, Link Matrix, System Dynamics, and System Architecture	105
Table 6-8 Indicative Measurable Information for System Description	106
Table 6-9 Needs – Metrics Matrix for Model A	108
Table 6-10 Freight Transport Options for the Private Sector	109
Table 6-11 Freight Transport Related Options for the Public Sector	110
Table 7-1 “Policy Packages” Proposed by Banister et. al as classified by OECD	121
Box 1-1 Architecting Heuristics for Sociotechnical Systems [Source: Maiers and Rehtin (11)]	20
Box 1-2 Architecting Heuristics for Collaborative Systems [Source: Maiers and Rehtin (11)]..	20
Box 2-1 The Bullwhip Effect.....	28
Box 3-1 The US Interstate Highway system.....	38
Box 3-2 A schematic example of how minimization of transportation externality costs will not create the optimum sustainability outcome	41
Box 3-3 Set of public policy decisions that influence supply chains.....	42
Box 4-1 A discussion of regional competitive advantage and cluster theory	48
Box 4-2 Performance Metrics Used by a 3PL (Ryder Logistics Inc. for General Motors -- MTE (52)).....	57
Box 6-1 Classification of Common Freight Flows [based on Niles MTI (50)].....	79
Box 7-1 Characteristics of the “Rational Comprehensive” model of transportation planning as quoted by Kane and Del Mistro (73).....	118

List of Figures

Figure 1-1 30.000ft View of the System Topology	15
Figure 1-2 The CLIOS Process [Adapted from Dodder, Sussman and McConnell (8)]	18
Figure 1-3 Methodological Approach.....	21
Figure 2-2 Current SCM Overview [Concept based on ESCAP (16)]	30
Figure 2-3 Snapshot of SCM – Factors and Developments.....	31
Figure 5-1 MPO/DOT planning framework [Source: (34)].....	64
Figure 5-2 The CLIOS Process.....	66
Figure 5-3 Nested Complexity in the CLIOS System representation.....	67
Figure 5-4 View of the Step 3 of the RSTP CLIOS Representation Process	69
Figure 5-5 Strategic Options in the Evaluation Stage of CLIOS	71
Figure 6-1 Classification of Common Freight Flows	78
Figure 6-3 Major CLIOS Subsystems for Region A	82
Figure 6-4 CLIOS Diagram of the Transportation Subsystem	83
Figure 6-5 CLIOS Diagram of the Economy Subsystem	84
Figure 6-6 CLIOS Diagram of the Land-use Subsystem.....	84
Figure 6-7 CLIOS Diagram of the Environment Subsystem.....	85
Figure 6-8 CLIOS Diagram of the Manufacturing and SCM Subsystem.....	86
Figure 6-9 CLIOS Mapping of the Institutional Sphere	87
Figure 6-10 Complete Systems Dynamics Model for Model Region A (All SD figures prepared using Vensim ® PLE Student Version (64)).....	95
Figure 6-11 Material Production Life Cycle & Resulting Transport Flows	96
Figure 6-17 Schematic View of a Freight Transportation System (FTS) from an SA perspective	99
Figure 6-18 Organizational/Functional and Physical/Structural Decomposition of an FTS	100
Figure 6-19 System Architecture Representation of Problem Statement and Concept of a Freight Transportation System (FTS) Using OPM.....	101
Figure 6-20 Micro-level Functional Decomposition of an FTS: Door-to-Door Delivery	102
Figure 6-21 Mid-level Functional Decomposition of an FTS: Supply Chain Strategy	102
Figure 6-22 Macro-level Functional Decomposition of an FTS: Regulations and Infrastructure Building.....	103
Figure 6-23 Structural Decomposition of the Institutional Sphere.....	103
Figure 6-24 Structural Decomposition of the Physical Infrastructure	104

Figures in Boxes:

Figure 2-1 The bullwhip effect: small fluctuations in the customer demand are amplified as they travel upstream the supply chain in the traditional order to demand. (In the figure, **the amplifications of the machine tool industry are shown.**) [Source: Anderson et al. (14)]

Figure 3-1

(left) Ton-miles carried by rail and highway as a percentage of total (excluding pipelines) -- (right) Actual fuel consumption of each mode. [Data source: BTS (2001)]

List of Acronyms

3PL	Third-Party Logistics
ATMS	Advanced Traffic Management Systems
B2B	Business to business
B2C	Business to consumer
CLIOS	Complex Large-scale Integrated Open Systems
CVO	Commercial Vehicle Operations
DC	Distribution Center
DSM	Design Structure Matrix
ETC	Electronic Toll Collection
EU	European Union
GDP	Gross Domestic Product
GIS	Geographical Information Systems
GRP	Gross Regional Product
HOS	Hours of Service (for trucking)
ICT	Information and Communication Technology
ITS	Intelligent Transportation Systems
JIT	Just-In-Time
LRTP	Long-term Regional Transportation Plan
LTL	Less-than-Truck Load
MPO	Metropolitan Planning Organization
MTE	Moving the Economy (Canadian NGO)
MTI	Mineta Transportation Institute
NGO	Non-Governmental Organization
O-D	Origin Destination
OECD	Organization for Economic Cooperation and Development
OPM	Object Process Methodology
ROI	Return on Investment
RSTP	Regional Strategic Transportation Planning
RFID	Radio Frequency IDentification (tags)
RFLP	Regional Freight Logistics Profile
SD	Systems Dynamics
SKU	Stock-Keeping Unit
TL	Truck Load
VAL	Value-Adding Logistics

1 Introduction

1.1 Problem Statement

This thesis argues that a *systems* perspective in regional strategic transportation planning (RSTP) for freight movements involves an understanding of the supply chain (SC). The private and the public sector have different agendas and planning horizons but at the same time may have common interests in the region that involve economic robustness, environmental health, and social cohesiveness – what is known as sustainability.¹ The success of Supply Chain Management (SCM) in optimizing business performance suggests that it is useful to transfer lessons learned from SCM to RSTP and vice versa but more importantly indicates that incorporating the private sector needs during transportation planning and freight-related policies may improve the sustainable development potential of a region. In the following we investigate how the two areas overlap and how lessons and practices from SCM can affect transportation planning with the ultimate goal of creating a comprehensive policy planning process for freight transport.

*Thesis
Statement*

Freight transportation is a ubiquitous characteristic of any advanced society. It is so common that it is almost taken for granted; this is true even when it comes to transportation planning, as indicated by Sussman and Conklin (2).² Freight transportation offers irreplaceable benefits to a regional economy by allowing economies of scale and scope to exist while comparative advantages due to location (e.g. proximity to sources of raw materials) can be fully exploited. Freight transportation is necessary for a specialized, urban society to exist.³ The use of freight transport on the other hand has a series of implications that range from direct impact to the environment of the act of transport itself⁴ to disruption of local cultural heritage due to the ease of acquiring or exporting resources. Second order effects are of major importance for analyzing the impacts of the freight system since the production and consumption of goods is facilitated through transporting them and the raw materials needed for their production⁵ while trade across borders contributes greatly to *globalization*.

*Issues and
Importance of
Freight
Transport*

The underlying issues and interactions of freight transport on a regional scale yet with global environment and economic implications make this a complex problem. The emerging field of Engineering Systems deals exactly with large-scale systems that have both technological and societal aspects. Engineering Systems provides investigative tools that employ a holistic approach and this makes them useful for analyzing our system. According to Joel Moses (4) the current goal in the field is “*not to solve problems but to learn how to state problems so that their essential character is clear.*” This thesis mainly states the problem using conceptual and practical models and makes a preliminary attempt to describe possible solutions – the latter is a task largely reserved for the continuation of this work as doctoral dissertation.

*Engineering
Systems*

¹ A historic reference to the sustainable development concept can be found in Dernbach (1).

² This “shortcoming” of transportation planning is discussed also in Chapter 4.

³ Runhaar (3) summarizes those impacts by stating that “[a] well-functioning and low-cost transport system facilitates international trade, which subsequently may increase economic efficiency through gains of trade and specialization. [...] In addition, an efficient transport system allows firms to optimize their production and distribution processes.”

⁴ Through, for example, vehicle emissions and use of land for infrastructure.

⁵ For a further discussion of the impacts of freight transport on sustainability see Section 2.4.

*Working
Definition of
the System:
RSTP/SCM*

Managing, designing and operating the system of freight transport on a regional scale is a profound and complex socio-technical problem that has multiple parameters. This intersection of RSTP and SCM is what we will define as the “system” for the purposes of this thesis. Applying engineering systems approaches to make a clear representation of the complex parameters that affect freight movements offers a fruitful approach for transportation systems planning on the regional scale. It can help the planning organizations and other stakeholders to transfer the focus from simple capacity planning to an understanding of the significant implications that transportation plans and operations may have on the development of a region. This thesis (i) represents the architectures involved in the system, (ii) discusses their interactions, (iii) poses policy questions, and (iv) proposes a framework for making informed decisions on the policy questions.

According to Crawley et al. (5) “complex phenomena become understandable [] after their essential modules have been identified and characterized.” By enumerating and characterizing the elements of the freight transportation system along with their interfaces we expect to create a generic model that would be adaptable to the needs of various regions and could provide guidance in designing efficient and if possible elegant architectures⁶ related to freight transport.

*Ultimately, this thesis can provide generic architecture guidelines for transportation system planners to assist in designing efficient transportation networks for freight in collaboration with the private sector based on policy objectives and supply chain needs. Architecture as used in this spans three main areas: **physical** (infrastructure), **technical** (operations, methods, technologies), and **organizational** (institutions, corporations, NGOs and their interactions).⁷*

A topology of the RSTP/SCM system is shown in Figure 1-1. The broad areas of the disciplines that are used to analyze them are shown as the ellipses representing Engineering Systems, and Systems Engineering with the former having a broader scope. The private and public sectors are presented as rectangles and their interface, which is our specific problem area is denoted by the star. The implication is that although the interface is a seemingly small area it has significant repercussions on the whole system.

The following section provides a more detailed overview of the system.

⁶ Elegant architectures appear when systems are very similar when decomposed in layers and have few interconnections between the layers. Crawley et al. (5) provide the example of the Apollo program where many subsystems were created based on similar architecture modules.

⁷ A clarification is required here in order to establish continuity with previous work on similar topics. Pendleton (6) provides a discussion of architectures and introduces “**regional architectures**” as “*a framework that describes how various transportation institutions will interact in order to provide an integrated series of transportation services in a metropolitan area.*” In later works, architecture appears as **operations and planning architecture** to denote the *institutional structure* that performs operations and planning respectively. Another transportation related appearance of architecture is as **ITS architecture** where is defined as “*a specific regional framework for ensuring institutional agreement and technical integration for the implementation of ITS projects in a particular region.*” (7) In Section 1.3 we present a broader definition of architecture based on the insights of Engineering Systems and on this definition we base the later use of this word.

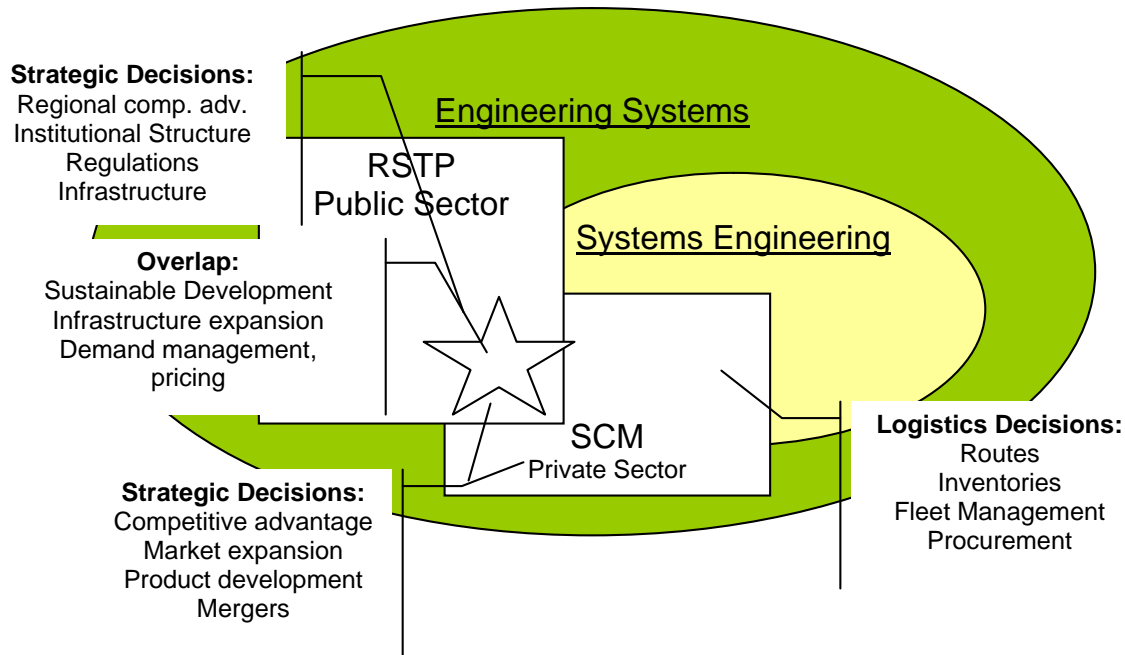

Figure 1-1 30,000ft View of the System Topology

1.2 System Overview

The system that we will be dealing with includes (i) the regional transportation network and the vehicles that can use it, (ii) the transportation planning and operating organizations, (iii) the firms that engage in the production, transportation and distribution of physical goods, and (iv) other entities that affect supply chain decisions.

*Basic System
Components*

This system can be classified as a *sociotechnical, collaborative system* based on the broad definitions given in Maier and Rechtin (11). It is *social* because its main objective is to provide for the physical needs of the general public without compromising societal well-being. The stakeholders involved are companies, government agencies and the public in general, which are all social entities. It is *technical* because it involves the operation of technical subsystems that range from vehicles to infrastructure networks and control mechanisms. The system can be characterized as *collaborative* because it is organized on a partially voluntary and/or evolutionary basis. From the choices faced by individual truckers to the large-scale modal choices of companies, the system behavior is defined by individual choices of participants⁸, subject to regulation and legal framework.

*System
Classification*

The two protagonists

Supply Chain Management offered a distinctive approach to logistics management in a development of a discipline that takes into consideration all aspects of running a company. This allows SC managers to optimize and coordinate different and ordinarily institutionally disconnected departments like operations, procurement, marketing and transportation.

*Supply Chain
Management*

⁸ Even on the infrastructure network level, the system can be seen as having evolutionary properties as shown by David Levinson and Lei Zhang (10).

Regional Transportation Planning On the other hand regional transportation planning has been less concerned with freight transportation as compared with traveler transportation and is slowly awakening to the fact that freight transport is at least as important to be run smoothly and efficiently as passenger transport and the two are of course interconnected.

Affiliation *Similarities and Differences: a juxtaposition of SCM and RSTP*
Supply Chain Management is focused on a corporation-specific agenda; yet it transcends the boundaries of individual businesses. In fact, the most important contribution of SCM can be argued to be the emphasis put on creating partnerships with the critical suppliers and distributors of a given company.⁹ The greater scope notwithstanding, SCM is still a practice that aims at improving the financial bottom-line of the businesses involved. While the typical private sector objective is financial success the public sector transportation planning authorities have a broader range of objectives; which ideally include sustainability considerations.

Location This increase of ties between companies does not imply a comparable connection with specific locations. In fact, as the barriers to international trade are lifted, corporate mobility has been increasing. Trends like off-shoring and outsourcing have created a highly mobile and complex environment in which flexibility is valued in the face of uncertainty. Of course this is not to say that regional commitment is extinct; on the contrary there are long-term decisions that have to do with establishing production and manufacturing centers, warehousing facilities and consolidation depots, and large retail outlets.

On the other hand transportation planning is highly localized. The interests of the planning authorities are connected with the needs of the region they serve. Creating a freight-friendly transportation system and involving the corporations of the area in the design and evaluation of the system creates an additional incentive for businesses to expand operations rather than relocating.

Planning Horizon Another area where there are differences between RSTP and SCM is the planning time horizon. The same pattern emerges; while SCM has a mainly short-term focus RSTP, has a long-term one. Due to a liquid market environment, most supply chain decisions have a limited planning perspective that does not usually stretch beyond two to three years and in most cases it is in reaction to or anticipation of market fluctuations and competitive pressures. Of course there are strategic decisions and commitments that have to do with facility establishment or partnerships that have longer-term implications.

This latter type of Supply Chain planning has similar scope as the RSTP with plans that usually span more than ten years. On the other hand there is a short term planning component within RSTP that has to do mainly with operations planning and maintenance. The fact is that although the public and private sector are focused on different time-scales but also conduct planning with similar scope makes the overlapping areas promising as test-beds of cooperation.

⁹ Of course, the diversity in the focus and needs of various companies does not allow for wide generalizations since companies choose to compete in different niches and hence create different expectations from their competitive strategy. Overall though, the current trend is for strengthening the relations of companies with their key suppliers and reducing the number of suppliers. These issues are further discussed in Chapter 2.

Table 1-1 Summary of Similarities and Differences

	SCM	RSPT
Affiliation	Private	Public
Planning horizon	Short and medium term. There are long term commitments related to establishing facilities.	Medium and long term and occasionally short-term for operations.
Location	Depends on the nature of the corporation but corporations are mobile.	Regional.

Table 1-1 contains an overview of the initial similarities and differences discussed above.

1.3 Methodological Approach and Engineering Systems Background

In the two previous sections it was indicated that the complex collaborative sociotechnical system of the interface between RSTP and SCM will be approached using Engineering Systems methods. In this section we discuss in more detail what those methods are and the insights they present.

The CLIOS Process

The main framework used to analyze the system at hand is the Complex Large-scale Integrated Open System (CLIOS) process. A detailed description of the CLIOS process is given by Dodder, Sussman and McConnell in (8).¹⁰ It is a process that is intended to provide a rigorous approach to complex, interdisciplinary problems where technology and society interface. The CLIOS process has three stages, subdivided into 12 steps. The stages are *representation*, *evaluation/design*, and *implementation* as shown in Figure 1-2. The first stage is system representation where the investigators describe the system's structure and behavior. Once the investigators understand the system they undertake the evaluation/design steps where different policies or solutions are developed and tested against the system model with viable, robust and yet flexible strategies are the goal. Finally, the refined solution is implemented and monitored. The CLIOS Process is also analogized as a Christmas tree, together with ornaments one hangs from the tree. The tree is the meta-process in principle usable for a wide variety of CLIOS. Applications in telecommunications, energy distribution, combat and other areas are underway. The ornaments represent the *tools* specific to a particular application. This is shown diagrammatically on the left side of Figure 1-2.

¹⁰ In order to assist the reader who is unfamiliar with the CLIOS process and terminology and also to establish a consistent use of the terms in our text, we attach a CLIOS Glossary of terms as Appendix I prepared by the author, based on team discussions, and two CLIOS papers: Dodder, Sussman, and McConnel and Harrison and Sussman (9).

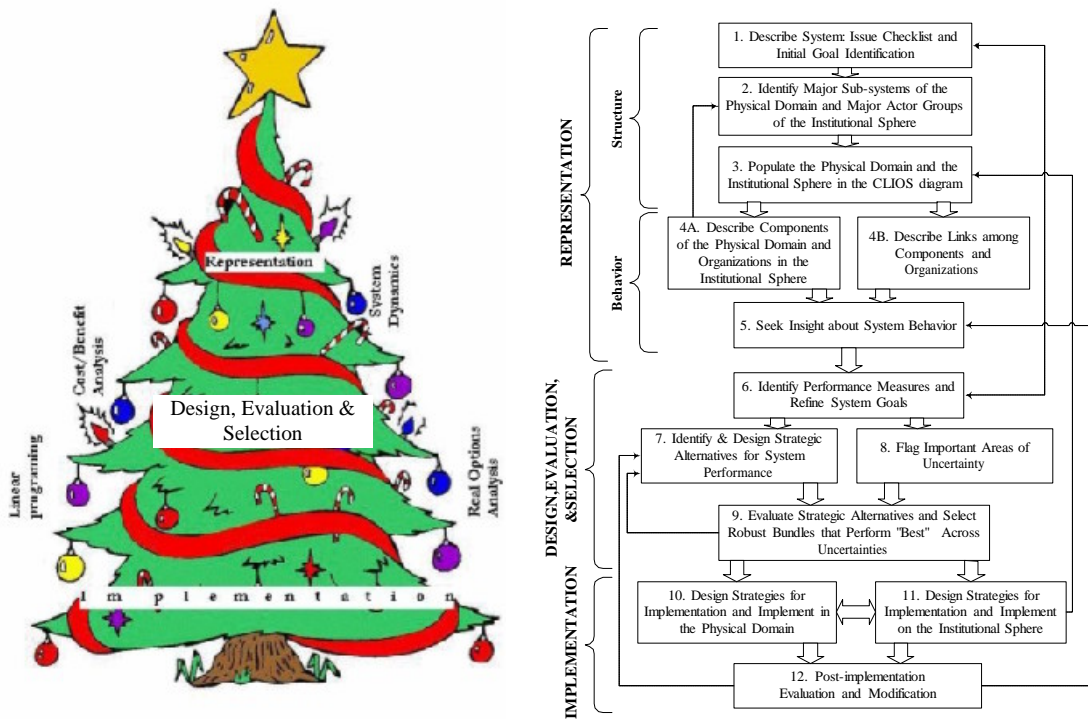

Figure 1-2 The CLIOS Process [Adapted from Dodder, Sussman and McConnell (8)]

Typical Characteristics of Engineering Systems

The systems studied by the discipline of Engineering Systems have common attributes and in this section we present those as they are used later in discussing the system at hand.

According to Moses (1) the following system characteristics are important: (i) complexity, (ii) uncertainty, (iii) emergence, and (iv) systems architecture.

System Characteristics

In addition, Engineering Systems emphasizes a set of system properties that include the traditional: *function, performance* and *cost* but extend them with a set of non-traditional properties which are also known as –ilities because of their usually shared ending. Moses (1) summarizes them as:

Traditional and non-traditional System Attributes

- Flexibility
- Robustness
- Scalability
- Safety
- Durability
- Sustainability
- Reliability
- Recyclability
- Maintainability
- Quality

Finally, CLIOS and Engineering Systems in general create a common background that pervades systems analysis: in a holistic approach they emphasize the behavior of the system as a whole. Large-scale systems typically exhibit emergent behavior (for both good and ill); they tend to change over time; and they are open to influence from outside agents. As a result, the focus is on managing change, studying the life-cycle performance and costs of the systems, and considering the feedback/reinforcing loops that can cause unpredictable behaviors.

Architecture

Crawley et al. (5) define architecture as “an abstract description of the entities of a system and the relationships between those entities.” Since the ultimate goal of this thesis is to provide guidelines for incorporating SCM considerations into transportation planning, the architecture of the system is critical in achieving this goal.

At least four classes of architectures are identified by Crawley et al. (5): “

- The functional architecture (list of activities that are needed to accomplish system requirements)
- The physical architecture (a node-arc representation of physical resources and their interconnections)
- The technical Architecture (an elaboration of the physical architecture [...])
- The dynamic operational architecture (a description of how the elements operate and interact over time [...])”

Freight transport is a system that combines a host of very different distinct architectures. The basic physical architecture is the infrastructure network that underlies every movement of freight. This is a designed yet evolved architecture (see also Levinson and Zhang (10)). On the other hand there are the non-physical operating and planning architectures of the transportation agencies. Another non-physical architecture is the enterprise for which the freight movement constitutes part of the supply chain. Supply chains themselves can evolve and/or be designed as such.

*Freight
Architectures*

Architecting

Architecting, according to Maier and Rechtin (11), is the process of designing the architecture in coordination with the client. It requires a vision and is greatly facilitated by heuristic tools.

Box 1-1 and Box 1-2 contain a collection of heuristic tools they suggest for facilitating the design of collaborative and sociotechnical systems.

Box 1-1 Architecting Heuristics for Sociotechnical Systems [Source: Maiers and Rehtin (11)]

- Success is in the eyes of the beholder (not the architect)
- Don't assume that the original statement of the problem is necessarily the best, or even the right one.
- In conceptualizing a social system, be sure there are mutually consistent answers to the Four Whos: Who benefits? Who Pays? Who supplies? And as appropriate, Who Loses?
- In any resource limited situation, the true value of a given service or product is determined by what one is willing to give up to obtain it.
- The choice between the architectures may well depend upon which set of drawbacks the stakeholders can handle best (not on which advantages are the most appealing).
- Particularly for social systems, it's not the facts, it's the perceptions that count.
- In social systems, *how* you do something is more important than *what* you do.
- When implementing a change, keep some elements constant as an anchor point for people to cling to.
- It's easier to change the technical elements of a social system than the human ones.

Box 1-2 Architecting Heuristics for Collaborative Systems [Source: Maiers and Rehtin (11)]

- *Stable intermediate forms.* During the construction or evolution of a system, stability indicates that intermediate forms are technically, economically, and politically self-supporting.
- *Policy triage:* Let the dying die. Ignore those who will recover on their own. And treat only those who would die without help. In collaborative systems, the decision of what not to control is critical.
- *Leverage at the interfaces.* When the components of a system are highly independent, the architecture of the system is the interfaces. The architect is trying to create emergent capability.
- *Ensuring cooperation.* In a collaborative system, the components actively choose to participate or not.
- *Standard development.* Standards are network goods and must be treated as such.

Methodological Approach

We approach the problem of investigating and architecting RSTP and SCM so that their interaction satisfies long-term system goals by following two seemingly different routes, sketched in Figure 1-3. First we describe and try to understand the two main components, SCM and RSTP, through describing their current state-of-the-art. Then, we represent the system from a top-down CLIOS approach, using the CLIOS diagrams and highlighting important areas where they interface. Next, simpler models are constructed and analyzed for a more direct view of the dynamics of the system. Finally, conclusions are drawn and architecture guidelines are sketched based on the performance of the models.

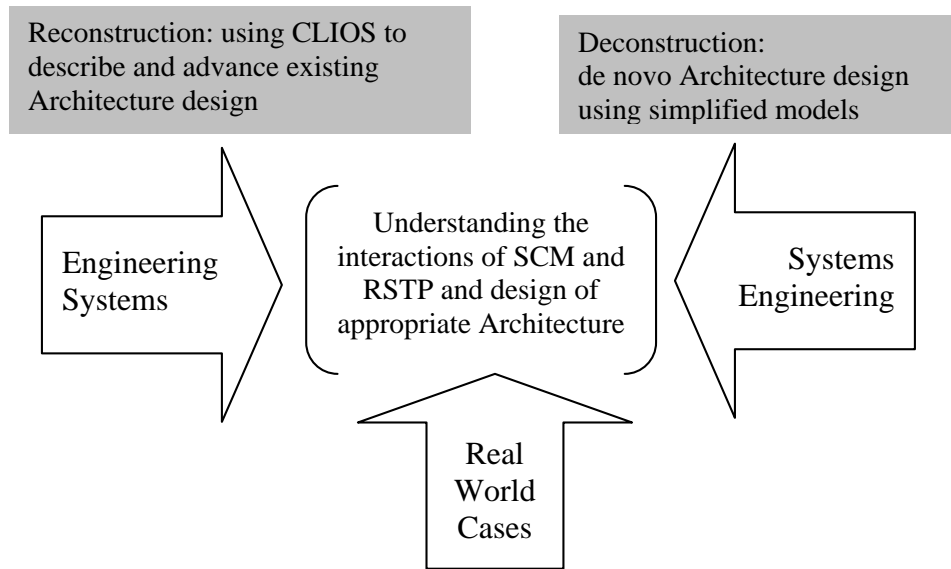

Figure 1-3 Methodological Approach

Future research

The conceptual models presented can be used as basis for system dynamic simulation models where the interactions can be made more plainly visible and more detailed experiments can be conducted.

1.4 Purpose and Objectives

SCM insights to RSTP

An SCM perspective in RSTP offers insights on the microscopic level in what are the drivers of freight flows within the region. This, combined with the macroscopic view offered by trade theory can lead to better decisions in transportation planning and coordinated and informed policies relevant to it.

The microscopic perspective offers insights in: (i) reasons that firms have for choosing suppliers within or outside the region, (ii) what are the important parameters for firms that affect modal choice of transport and how different policies can affect them, (iii) what provides competitive advantage to firms and how this can be linked with competitive advantage for the region.

The macroscopic perspective tries to connect how large changes in infrastructure, transport costs and policies affect the performance of the firms. Traditional economic models anticipate expansion of markets and increased competition due to penetration of the regional economy by firms from other regions as the logistical barriers are lowered.

Policy Questions Raised

This thesis creates the background to raise and attempt to answer previously unaddressed policy questions related to freight RSTP in an analytical quantitative and qualitative way.

In the face of higher fuel costs and potential impacts of emissions on global climate, how can policies promote efficient modes as alternatives that offer lower energy-intensity per ton of cargo (like rail and water shipping) without disadvantaging the region's companies with longer less reliable transit times and the related inventory costs? Do such policies make sense? Are policies that anticipate the advent of higher fuel prices by investing in currently under-utilized more sustainable facilities as a real-option advisable?

From a regional perspective centralized activity in hubs also is important since there are greater positive spillover effects. This makes ports, rail yards, intermodal facilities, and logistics centers that revolve around consolidated modes more attractive than a dispersed system based solely on trucking.

Modes based on consolidation and hubs also cater to areas that extend beyond the boundaries of the region and therefore bear both the positive externalities mentioned above but also negative externalities that have to do with added pollution and congestion. Without an adequate pricing scheme these areas effectively subsidize trade of areas outside the region. A similar theme is the trade-off presented by competitive behavior among regions for the provision of transportation services which can lead to overcapacity. At the same time, this regional competition is known for increasing levels of service and reducing transport costs.

1.5 Thesis Outline

In order to answer, even partially, the above questions several seemingly independent yet interrelated topics need to be discussed. For this reason the thesis is separated in 3 parts: **Part 1** qualitatively discusses the two different aspects of the system that is Supply Chain Management (SCM) and Regional Strategic Transportation Planning (RSTP) as well as their interface; **Part 2** introduces a framework for transportation planning based on the CLIOS process and implements this framework for tying SCM and RSTP; finally **Part 3** concludes the discussion by proposing policy bundles to be considered as further research.

- Part 1* **Chapter 2** presents the current developments in Supply Chain Management. The strategic importance of supply chain decisions is stressed as well as the relative influence of transport costs on total logistics costs as well as potential market and competition costs. **Chapter 3** expands the other half of the equation; that is the Regional Strategic Transportation Plan. The important planning parameters considered and a generic outline of the planning process are presented. **Chapter 4** discusses the interface of SCM and RSTP based on existing literature and a discussion of real-world cases where policies for freight and supply chains were implemented. As a general comment, freight transport seemed to have a relative low priority in the considerations of traditional RSTP.
- Part 2* To counter this and other perceived shortcomings in the current transport planning practice an implementation of the CLIOS process as a planning methodology is presented in **Chapter 5**. **Chapter 6** introduces the basic models that are used for architecting based on the systems engineering, bottom-up approach.
- Part 3* Finally, **Chapter 7** discusses how the insights gained from the model framework developed in Chapter 6 can be applied in real-world cases and lays the plan for further case-oriented research on the subject.

PART 1

System Description

We cannot solve our problems with the same thinking we used when we created them
-Albert Einstein

2 Supply Chain Management Basics: background, goals, methods

This chapter presents an overview of the Supply Chain Management (SCM) concept. On a global scale, the number, diversity, degree of innovativeness and geographic dispersion of companies guarantee a large spectrum of different SCM applications. This presentation initially focuses on the generic properties that are observed in SCM implementations. Secondly it summarizes SCM goals as well as the methods that firms use to implement it, along with some textbook examples. Finally, the areas that intersect with the Regional Freight Transportation Planning (RFTP) goals and methods are discussed in more detail, providing segues for the following chapter which introduces the RFTP side.

2.1 SCM basic definitions

There is no universally acceptable definition of SCM and logistics, so for the purposes of this thesis we will use the following definitions:

Logistics is the managing of all needed resources for the completion of any given activity. It may include acquisition, movement and storage of materials and information as well as the transport of personnel.

This definition reflects the generality of the term that can be used from personal activities (i.e. the logistics of a trip) to the provision of supplies and troops for a military operation. For freight operations, logistics can be used to describe the transfer of materials to feed a production line as well as the procurement of fuel for the trucks. It can be general and inclusive.

Supply Chain Management is a more narrowly focused concept in the sense that it is used mainly in the context of commercial (and military) operations. At the same time it is inherently more general than the logistics concept since it explicitly considers a whole set of links (supply chain) that lead from upstream raw materials acquisition to downstream end product retailers and finally consumers.¹¹

Supply chain is the network of processes that are associated with the procurement and delivery of raw materials, their transformation into product, and its distribution to the end consumer. As a result, the supply chain includes suppliers, manufacturers, warehouses, distributors and retailers.

For commercial applications supply chains usually refer to material flows for individual companies or individual production lines. Depending on the level of research detail, supply chains extend beyond the directly upstream suppliers to the second, third or higher tier (the supplier's supplier).

This allows us to make a working definition of Supply Chain Management for this thesis:

¹¹ Later in this chapter I propose the post-consumer view as inherent part of a "sustainable" supply chain.

SCM is the process of orchestrating the flows of goods and integrating information flow in a given supply chain. The ultimate goal is to establish the globally optimum cost structure for given service level requirements.

Simchi-Levi et al. (13) define SCM similarly as “a set of approaches utilized to efficiently *integrate* suppliers, manufacturers, warehouses and stores, so that merchandise is produced and distributed at the right quantities, to the right locations, and at the right time, in order to minimize systemwide costs while satisfying service level requirements.” In both definitions the need for some kind of vertical integration among the tiers of the supply chain emerges as critical.

Firms are expected to collaborate with the links that are critical for their products. Critical suppliers are those that provide or can potentially provide a value-added service that goes beyond commoditized goods. To give a standard example, the supplier of steering wheels S to car manufacturer T that is willing to offer just-in-time reliable shipments by transferring their production facilities or distribution center close to the main auto facility provides an additional value to T and can be paid a per-unit premium. T in its turn by absorbing those wheels at pre-decided rates provides value to S. The above example introduces the concept of the *value chain* that underscores the SCM message.

The SCM model became mainstream practice during the past thirty years. In the following section, we examine the main characteristics of the SCM paradigm and the reasons that increased its appeal in contemporary logistics. Since there is value in understanding the underlying presumptions of SCM for successfully integrating it with policy planning, we will make a schematic presentation of SCM developments along with the pertinent factors that enabled them.¹²

2.2 The basics of contemporary SCM practices

If the spread of SCM can be traced back to a single event, then this event cannot be other than the adoption of just-in-time manufacturing by the Toyota factories in Japan. The new service level requirements that this practice posed led Toyota to re-establish relationships with its suppliers in a controlled way. Toyota’s success story provided a model that was to be replicated, improved and adapted many times in the later years; what this implies is that there were pre-existing conditions that provided fertile ground for the SCM seeds to flourish.

Runhaar (3) attributes the emergence of the SCM model (a) to the increased competition in the global markets due to liberalization and consumer preference, (b) the emergence of new information and communication technologies (ICT) that enabled actions previously impossible, and (c) the success of the pioneering Toyota model.¹³ To these main motivations we would add (d) the global diversity in regulations, labor costs, and taxes that provided substantial economic advantages to be gained by internationalization of supply chains and (e) the advances in transportation technology and the deregulation of freight transport that allowed for decreased transport lead-times, efficient intermodal changes, and decreasing real costs per transported unit.

¹² Any attempt to disentangle the cause and effect matrix of SCM development can easily become complicated, contradicting, oversimplified or a combination of those, so I request the understanding of the reader when I make any of the above mistakes.

¹³ Runhaar (3), pg 39. He also references the following sources: Cox (1999), Demkes (1999) Laarhoven (1999) and others.

Increased competition among companies that market consumer products has various impacts on their behavior and the requirements that firms put on their supply chain.

One result of increased competition is the need to differentiate products and thus offer customer value in customization. This market state led to what is known as “mass customization.” Mass customization usually is a combination of varying degrees of delayed configuration and postponed manufacturing. The *Dell* market model offers a characteristic example of mass customization practices: Dell relies on acquiring what they call “vanilla” stock components that they can then assemble into working computers as soon as the customer order is made. On the clothing manufacturing front, *Benetton* follows on the same lines by acquiring un-dyed or “gray” garments and dyeing them according to seasonal fashion. *Zara*, a rising European manufacturer of low cost fashion clothes, on the other hand pre-manufactures approximately 20% of its sales and responds directly to demand after taking into account real information on consumer preferences from their stores. Finally, car manufacturers offer pre-manufactured versions of the same basic models to cater to various customer needs and price sensitivities. In the extreme, the idea of catering to the individual customer needs has almost been reversed in the sense that firms have invented ways to persuade customers to buy what the firms’ have currently in stock (which is the driving force behind end of season sales) while retaining the feeling of individual choice.¹⁴

Mass customization

Another effect that can be attributed to increased competition is the move towards “lean” supply chains. Most producers have realized that now carrying inventory incurs costs that exceed the depreciation (devaluation cost) of capital. As *Cisco* and *Dell* learned through hard experiences, inventories of obsolete equipment could burden the company with millions of dollars in inventory write-downs.¹⁵ As a result of similar situations the *inventory turn-over ratio*¹⁶ is now considered a visible aspect of the dynamism and health of a company and is highly appreciated by investors in the stock market.

Inventory Reduction

The models of *Dell* and *Zara* with their manufacture-to-demand capacity offer one method to reduce costly inventory of finished products and transfer the risk to lower value levels in the supply chain. Manufacturing after the order is placed is the absolute way of increasing the transparency in the supply chain. As a general rule, it has been shown that by increasing transparency in the supply chain, the effects of the “bullwhip” phenomenon which is presented in Box 2-1 can be significantly mitigated. Of course manufacturing-to-demand creates the standard cost balancing act by significantly increasing transportation costs since product have to be individually shipped to the consumer on short notice while reducing inventory costs.

¹⁴ Dell offers again an example of this system: the prices posted on their website for computers and accessories are constantly updated to reflect their current supply.

¹⁵ Simchi-Levi (13) mentions that “in 2001 Cisco took a \$2.25B excess inventory charge due to declining sales.” Runhaar (2003) points out that the life cycles of consumer products has been rapidly decreasing enhancing the obsolescence rate of inventory. Of course the consumer companies have contributed to this trend by their intensive marketing and promotion of not very substantial advances over previous products as major breakthroughs.

¹⁶ *Inventory turn-over ratio* for a company is the ratio of total annual sales over the average inventory level held by it [See Simchi-Levi (13) pg. 33 for more details].

Box 2-1 The Bullwhip Effect

Traditional logistics relied heavily on inventory keeping and manufacturing ahead of time in order to provide a buffer against stock-outs. This practice invariably results in the infamous “**bullwhip effect.**” The mental picture of a whip that increases its oscillation width with relatively small initiating movement on the handle is an apt metaphor for the phenomenon.

In each level of the supply chain, managers know that there is a delay from the moment an order is placed to the moment the ordered products are received, which is known as **lead-time**. They also know that they have to protect their business from **stock-outs** and the implied potential loss of sales. This creates the need for inventory as buffer. Small fluctuations in consumer demand are amplified significantly as they are translated into orders from the retailer to the wholesaler, from the wholesaler to the distributor, and from the distributor to the manufacturer and the greater the lead-time the more the amplification increases. This is schematically shown in Figure 2-1.

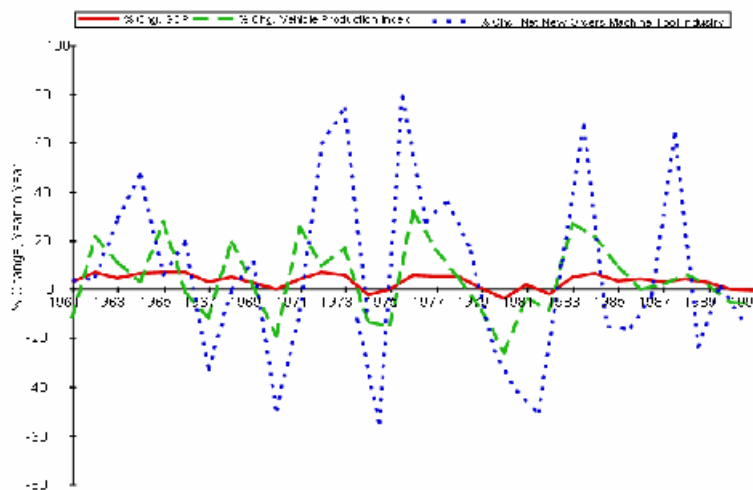

Figure 2-1 The bullwhip effect: small fluctuations in the customer demand are amplified as they travel upstream the supply chain in the traditional order to demand. (In the figure, the amplifications of the machine tool industry are shown.) [Source: Anderson et al. (14)]

The bullwhip effect results in higher than justified production and warehousing capacity, higher inventory levels and hence higher inventory carrying costs, and as a result of the high inventory it may often result in stock devaluation because of obsolescence. Simchi-Levi et al. (13) pg 105, offer mathematical representation showing that for a simple moving average forecasting model, the variance increases multiplicatively to lead-time, while in a transparent supply-chain proportionally to lead-time.

*JIT
delivery*

Since most production processes are not yet adapted in manufacturing to demand, other methods of reducing inventory have also been widely employed. These methods tend to focus mainly on lead-time reductions within each level of the process and better planning of production to alleviate the need for inventory. Translated in our previous example it means that the assembly

line of cars T should continue to run unobstructed without having to rely on an inventory of steering wheels; S is expected to deliver a new batch of steering wheels exactly when needed or *just-in-time* and thus act as *in-transit inventory*.

In order for such an interdependent system to function, confidence in the transportation system as well as the suppliers is extremely important. From the introduction of the Toyota model, it became obvious that further reduction of lead times could only be achieved through better collaboration with the chain of suppliers and retailers. A special case of vertical integration that also provides increased supply chain transparency and inventory reduction is the *vendor managed inventory* (VMI). In this scheme, suppliers take responsibility for replenishing the stock at retailer locations and in most cases they retain ownership until the product is sold. This way, suppliers can optimize their production plans and have total visibility of retails while retailers are relieved from replenishment or inventory risks. In the end and interestingly enough, our initial observation of increased competition in the end product dictates a greater need for cooperation through the supply chain and a tendency for some type of vertical integration along its lines, or as John Kasardra (15) of the University of N. Carolina put it: “*it is not firms that are competing anymore but supply chains*” and we would add regions.

One other interesting by-product of JIT delivery practices is the introduction of *cross-docking* facilities.¹⁷ Cross-docking centers replace traditional warehouses but minimal or no inventory is stocked in their premises; their main purpose is to act as shipment consolidation hubs and in some cases provide “light manufacturing,” i.e. packing or labeling of products. The cross-docking concept would not be practical though without direct availability of shipping information and *pipeline visibility* since it relies on receiving shipments from different production facilities almost simultaneously and consolidating them in the shipments that leave to replenish stock in various retail outlets.

Information and Communication Technologies (ICT) advances were critical to the successful implementation of most of the strategies discussed above. Transparency of the supply chain, i.e. real-time information on customer demand can only happen through electronic networks and the Internet. JIT delivery is based on an array of technologies that range from ITS fleet management technologies to real-time tracking of trucks or even individual shipments. Another area where ICT advances have been incorporated in the supply chain layout is the *Electronic Data Interchange* (EDI) system. These technologies, first put in place before the widespread use of the Internet, allow paperless expedient transactions. Orders can be placed, shipments can be arranged, and rates can be solicited in an integrated environment that connects all interested parties. Any changes made on the system can directly reflect on the companies internal records. While EDI systems have been used solely by larger corporations, widespread Internet use created the *e-commerce* market. Businesses independent of scale and individual customers can get benefits similar to EDI, create customized procurement solutions¹⁸ in business-to-business (B2B) environments or create access directly to consumers with business-to-consumer (B2C) schemes like Amazon or Dell’s web store.

¹⁷ Walmart pioneered the cross-docking concept and based part of their success on it.

¹⁸ It is interesting to notice that the effect of electronic procurement, usually in a lower bidder auction scheme, drives away from the integrative forces discussed elsewhere. Although integration and auctioning may reflect different firm cultures they can also coexist in a scheme where purely commoditized parts are auctioned and only the critical suppliers obtain partner status.

*Transportation
advances*

Even with ICT technologies in place, “hard”¹⁹ transportation advances and the extensive utilization of the publicly-backed infrastructure network were critical in the SCM success. Supply chains have traditionally adapted to the transportation opportunities available in a way that changed their geographic and market penetration. Advances in speed (availability of air-freight) or facilities (refrigeration) opened potential markets along with reduction of real transportation unit prices. (Note: more extensive coverage of transportation issues will be given in another chapter or section. Perhaps the RFTP)

*Geographic
and
Market
Diversity*

The advances in transportation mentioned above that allowed economic transfer of goods from continent to continent (along with political developments like the liberalization of the Eastern block markets) expanded potential markets to cover essentially the whole globe. Opening of markets did not eliminate differences from regulatory standards and profit taxation to labor costs and raw material availability. This type of diversity can be found even within national borders and has profound impact on supply chain decisions. Import duty variations, to pick one among thousands of examples, can alter the decision of whether to import a product as finished good or provide final assembly across the border. Regional and global trade agreements, like NAFTA, ASEAN, and WTO as the continuation of GATT, work towards partial homogenization of the regulatory regimes while other differentiating aspects like environmental regulation and labor costs remain more or less intact.

The two figures that follow provide an illustration of the discussion above. Figure 2-2 shows the extent of information flows from as far as the product design to the customer in a closed loop fashion. Material flows used to be considered as one way from the manufacturing process to the customer, yet this notion has been recently enhanced to include the reverse logistics flow from returns due to dissatisfaction and as we will see later in this chapter the flow of products that reached their life-span and are returned to be dismantled and reused by the manufacturer.

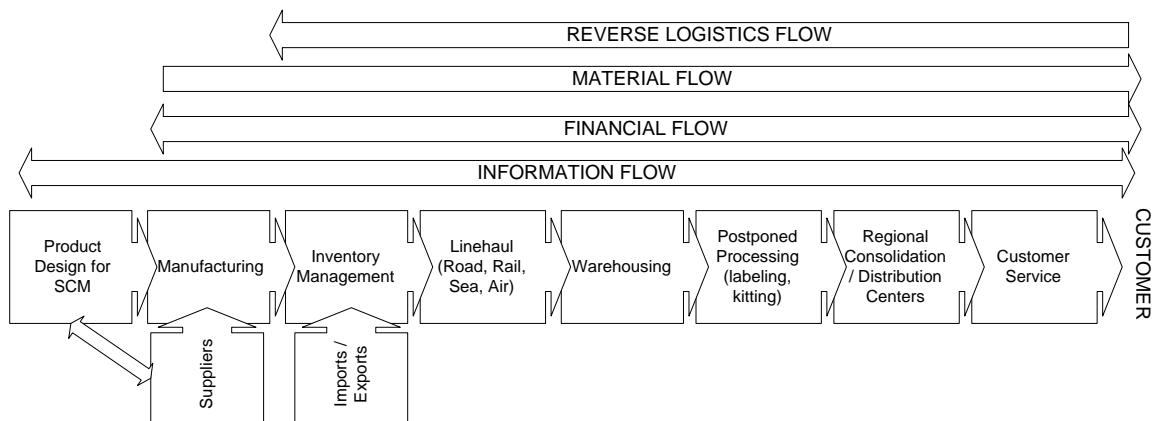

Figure 2-2 Current SCM Overview [Concept based on ESCAP (16)]

Figure 2-3 places in perspective the drivers and reactions that pushed the development of SCM from a simple logistics notion of delivering the product to the customer to the competitive advantage “weapon” discussed above. Technology advances in transport and telecommunications were the enablers of the increased drive for competitiveness that the trade liberalization and the globalization of the economy provoked. The plethora of firms in the global market empowered

¹⁹ Vehicle capacity, average vehicle speed, quality and capacity of networks etc. “Hard” here is opposed to the “soft” advances of ICT.

customers to demand higher quality at lower cost. Firms responded in a variety of ways; delaying product differentiation through mass customization, reducing inventory costs through JIT delivery and cross-docking, implementing streamlined order and delivery systems based on EDI, and by vertically integrating the functions that were crucial to their competitiveness while outsourcing those that were not.

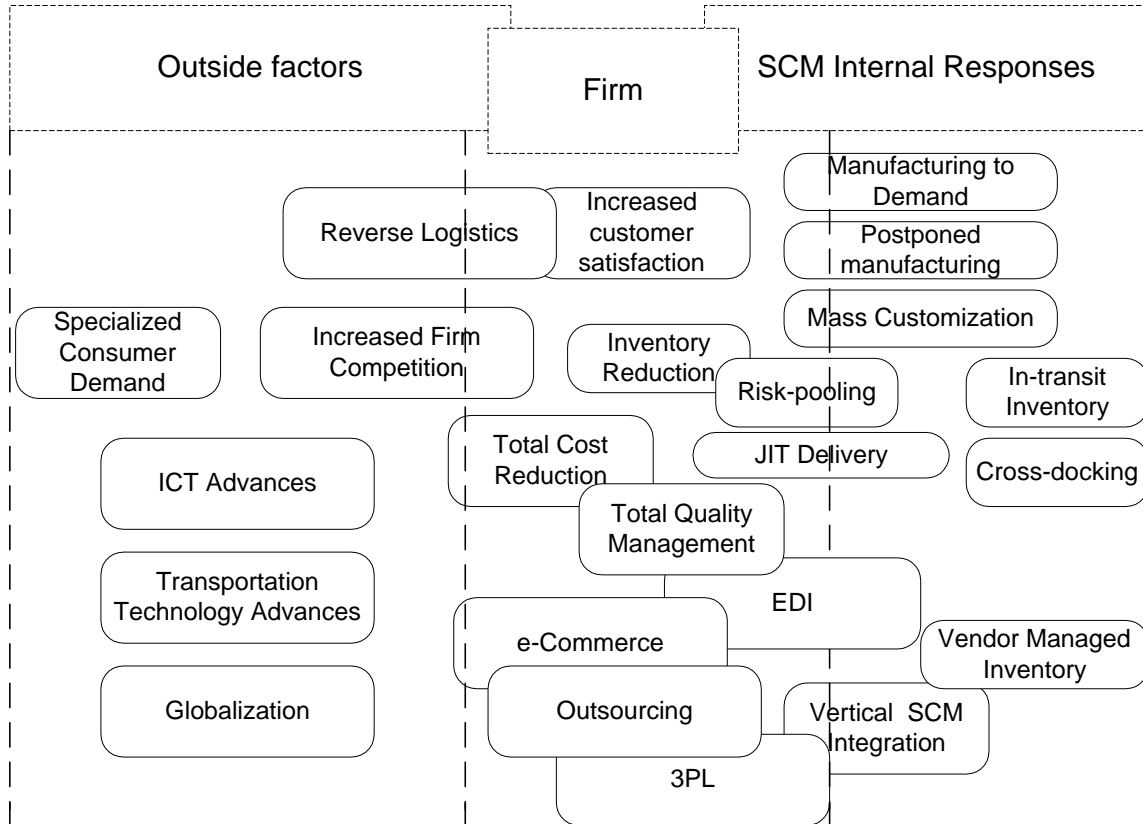

Figure 2-3 Snapshot of SCM – Factors and Developments

To summarize, this section made a generic presentation of SCM development issues. In the first half of the next section we will deal with the design of supply chains and present the parameters that are important in this undertaking including insights from specific major supply chains. The second half will interpret these design parameters into their implications on the transportation system and the transport-oriented sectors.

2.3 SCM Design and Implications

2.3.1 SCM design parameters

The rational and efficient design of supply chains is one of the main objectives of SCM that works toward the greater goal of system-wide optimization. According to Mangan (17)²⁰, supply chains are designed based on balancing all or some of the following parameters:

²⁰ List adapted and expanded by the author.

- Product type and market niche
- Cost
- Resiliency requirements
- Suppliers: sourcing (make vs. buy decisions)
- Retailers: vendor managed inventory (VMI) or traditional retailer-owned stock
- Lead times
- Mode: surface, intermodal and/or air freight
- Use of individual or consolidated shipments
- Customs and trading regulations
- Partnering with a third party logistics provider (3PL or 4PL)
- IT Requirements and pipeline visibility,
- Location and number of facilities and distribution centers (DCs)
- Choice of transport provider i.e. transport service only vs. combined with value adding logistics (VAL)

Cost Supply chains will vary significantly based on product type; even for the same type of product, firms may differentiate in terms of the market niche they want to compete in and this impacts their supply chain requirements. At the same time, the value of the final product plays an important role in the supply chain solution and the associated transport costs; more valuable products more easily absorb the extra costs of premium services.

Resiliency While cost has always been a primary concern, resiliency has gradually shifted into focus especially after terrorist attacks or strikes disrupted supply chains and caused losses estimated in billions of dollars.²¹ Although not all supply chains need some resiliency, industries that rely on JIT deliveries and where disruptions can lead to plant closures resiliency is critical and the cost of maintaining alternative supply routes has to be balanced with the potential risks of supply disruptions. Formal risk analysis can be used to assess the vulnerability of links as well as to estimate the probability of disrupting events and thus assist in design decisions.

Supply and Distribution Networks The choice of supply and distribution network is another critical parameter in the design of supply chains. Identifying the cost-efficiency in one of the following choices from producing a product internally to outsourcing it completely, and from outsourcing components to outsourcing final assembly is a design choice that may not have a straightforward answer. The same is true for the distribution network and whether to follow a VMI strategy or not. In the US market, and in other markets in a lesser degree, the distributor power has been increasing and the choices that a manufacturer faces may be limited by this. One example is *Walmart* and the anecdotal evidence that associated with its practices of forcing their suppliers into the lean mentality, or “squeezing them,” to quote Fishman (18).

Lead-time The lead time for final product delivery is another inter-related design parameter. Although it is conceivable that reductions in lead-time are achieved by altering the manufacturing process itself, the most common way for reducing lead-times concentrates on the transportation and distribution network. The cost, speed and reliability of transportation modes comes also into play in this decision process as well as the choice of the type of shipments. Companies used to object to consolidation of their shipments with other products especially those of direct competitors. With the trend towards smaller shipments this mentality seems to slowly change. The emergence of 3PL providers have significantly eased this tradition since their customer consignors can ignore

Transport Mode

²¹ Of course, there are techniques that can translate resiliency into costs like risk evaluation analysis. Yet these may or may not convey the actual importance of a disrupted supply chain.

how the transportation of their products is done as long as it is reliable and in accordance to their requirements (i.e. reduced vibrations, refrigeration etc for sensitive goods).

The choice among outsourcing the logistics solution to a 3PL provider, retaining control of the immediate supply chain but outsourcing transport (VAL or not), or finally keeping internal fleet (trucks, rail-cars, or even cargo planes) is again dependent on a series of other parameters. Current conventional wisdom advises the use of 3PL²² unless the firm's core competency lies in the efficiency of their logistics, but even *Walmart* has contracted out to such providers. Dedicated carriers have the potential advantage of economies of scale and specialization for their fleet maintenance while they can exploit network economies and consolidate shipments or find backhaul cargoes.

Finally, the decision on the number and location of production facilities and distribution centers (DCs) is a crucial one. On one level, it is dependent on transportation access and costs, availability and proximity of raw materials, and proximity and importance of markets dependent on expected demand. For example, more DCs represent higher inventory costs but less lead-times for market access while central DCs due to the *risk pooling*²³ effect make forecasting less critical and reduce inventory costs. On another level the effects of variations in regulatory, profit taxation and import duties as well as differences in labor costs or even environmental regulations have to be taken into account. Their effect is especially pronounced when designing international supply chains.

*Location
and
Risk-pooling*

2.3.2 SCM Discussion: Issues, Trends, and Implications

Although it is quite difficult to deduce general trends from sometimes contradicting tendencies in the logistics and transportation sectors, in this sub-section we attempt to classify the trends and mentioning the contradictions when they occur. The focus will mainly be on those aspects that have transportation implications.

Runhaar (3) notes the tendency for co-location of the industries that belong in one supply chain. The car manufacturing sector, following the Toyota example, tends to concentrate facilities so that lead-times are reduced to less than hours. On the other hand, he points to the relocation of main manufacturing facilities to low-cost countries and the transfer of final assembly close to the markets.

According to Runhaar, the trend in DCs is towards centralization and presumably the increased transportation costs and final lead-times to the retailer are compensated by the reduction in inventories. In addition, DCs take over other VAL roles that involve large part of *reverse logistics* that is return of goods and even customer information or repairs.

These trends have led to a greater dependency on truck delivery at least in the final legs of national supply chains while intermodal deliveries, that usually involve an ocean and a land leg

²² A note on 3PL and 4PL. Third party logistics providers are entities that own fleets and may contract independent carriers for certain moves or if their capacity is overwhelmed. 4PL are "no-asset" providers, that is they do not have their own fleet and only provide value with their expertise in orchestrating the transport. 4PL has not caught up although UPS claims to offer 4PL services in the sense that it may contract a competitor if their bid is better than UPS' (see UPS website). Whether this is a 4PL practice is debatable.

²³ Centralized DCs that cater bigger geographic areas and populations can be planned based on average demand forecasts compared to smaller markets that tend to exhibit more volatile behavior. The success of large online vendors like *Amazon* is partially attributed to this factor.

by truck or rail, have dominated international supply chains. The significant modal variations in transport costs are enough to lead to counterintuitive supply chains. The shipment of a container of electronic goods from Munich to Bremen costs the same as the shipment of the same container from Singapore; or the shipment of cement in bulk from Bulgaria to New Jersey costs less than its transport by truck from let's say Georgia, to name a few anecdotal cases. On the other hand, as we have seen, the increase in the cost of capital due to prolonged transportation as well as the drive to reduce inventory and lead times to respond to customer demand may drive the decision towards local production. Another parameter that favors local production and consumption is the differential currency fluctuations; to give one example, BMW by building the cars that sell in the U.S. at their local U.S. facilities have avoided the impact on their competitiveness that the unexpected rise of the Euro would have if they imported those car from Europe.

The above discussion indicates that there is variety of paths and possible combinations that supply chains can take and that they can rapidly evolve based on global market changes. This environment is not conducive for stating generally applicable implications of supply chains. As later discussed extensively in Section 5.1.3, regional implications of supply chains are not clear-cut. However some observations can be made; for example:

- Trucking and to a lesser extent truck-rail intermodal is currently the mainstay of land freight transport.
- Demand for air-freight is rising at a higher-rate compared to other modes.
- The weight of shipments is reduced and their frequency increased; however advanced consolidation techniques counter this trend and may even increase the average weight of vehicle-loads.

The takeaway from this discussion of SCM is that there are no panaceas, or silver bullets, followed in the majority of supply chains. Each type of product has a unique type of supply chain and it varies from company to company. Of course the leader corporations often create successful prototype solutions but even when these are implemented outside they will lead to different supply chain structures. The timeframe for creating or restructuring a supply chain ranges usually from three to five years, but Bruce Arntzen, the VP of Avicon that specializes in supply chain consulting, proposed that this timeframe should range from one and a half to two years (19).

2.4 Missing pieces in the SCM puzzle: a sustainability perspective

What seems to be neglected in the SCM discussions currently are the implications of the SCM strategic choices in the environment and the society. From a sustainability perspective, while the economic aspect of SCM has been handled successfully there has been a lack of proportional interest to the two other aspects, that is the environmental and equity impacts of the supply chains.

As a starting point of the discussion for sustainable SCM we include the following propositions:

Proposition 1: A sustainable supply chain should include the “product as nutrient” concept and thus incorporate the necessary or recommended post-consumer moves of the product as related with the specific product line and supply chain.

Proposition 2: A sustainable supply chain has to balance optimum total costs with minimum *total externality costs*.

Proposition 1 suggests that landfill trips, returns of unwanted products, returns of leased items, returns for disassembly and all other kinds of reverse supply chains have to be explicitly

considered for the estimation of total costs (internal – external). Proposition 2 goes one step further and extends the existing supply chain concept of optimization of total costs including production, inventory holding, and transportation to the minimization of total externality costs. These externality costs could for example include the societal costs of relocating facilities, the environmental costs of actual production, and the environmental costs of transporting the products to the market.

The concept of the “product as nutrient” as proposed by McDonough and Braungart (24) involves a re-design of products so that they can either be safely disposed providing nutrients to the natural environment or at least without causing harm and if this is not possible being easily reused without downgrading.²⁴ Of course, such a shift of perspective raises significant complexity issues while the existing problem of SCM design is complex enough. This requires a change in the mentality of corporations that may already be underway but it may still require regulatory measures and other institutionalized incentives since market forces are weak in creating incentives for companies. Regarding the reverse logistics issues, there are already in place regulations (although as of 2003 not yet effective) that will require the collection and reprocessing of used electronic equipment as well as the European Union requirements for the recyclability of car parts. Companies like *HP* and *IBM*, have started pilot projects for collecting back the discarded equipment mainly to avoid liability litigation based on alleged contamination of water supplies and soil.²⁵ Similarly, the Department of Energy in the U.S. is considering the impacts from implementing regulations similar to those in the E.U. regarding automotive end-of-life recyclability (22).

2.5 SCM Design Overview

To summarize, the key design parameters (or components) of SCM can be identified on four levels²⁶:

- **Product Design Informed by Supply Chain Requirements.** Product design can take into account the demand forecasting based on supply chain data, the limitations or requirements posed by the product’s expected market penetration (regional differences like language, currency, voltage, plug configurations etc), the ability of suppliers to produce and/or improve the product’s critical subsystems.
- **Strategic Network Design and Optimization.** At this level, the number, capacity and location of plants that will be used is decided. Key suppliers and sourcing strategies are determined along with necessary warehousing facilities and supply chain strategies like JIT or cross-docking.
- **Supply Chain Master Planning.** Specific distribution strategies, production quantities and inventory levels are decided in order to maximize profits based on promotions, demand-spikes and seasonality.
- **Operational Planning (Short-term).** At this point the system focuses on developing *feasible* strategies instead of *optimized* solutions because of the difficulty to integrate among the following factors:
 - *Demand planning.* Short-term demand forecasts.

²⁴ Downgrading means that the recycled material is of inferior quality and usually cannot be put back to the original use.

²⁵ The problems posed by the toxic waste from discarded electronics is eloquently portrayed in Grossman (20).

²⁶ This section is based on Simchi-Levi et. al. (13) Chapter 11 as well as the SCM entry in Wikipedia

- *Production scheduling.* Detailed production plan based on demand forecasts and the SC master plan.
- *Inventory management.* Inventory for the various facilities.
- *Transportation planning.* Transportation routes, schedules, fleet planning and distribution planning.

The planning horizon, implementation complexity, and return on investment (ROI) for actions on each of the above levels tend to follow a pattern from long-term, not very complex, high-yield to short-term, complex, low-yield as shown in Table 2-1.

Table 2-1 SCM Planning Parameters Overview²⁶

SCM Layer	Influenced Factors	Planning horizon	Return on Investment
SC-informed Product Design	Regional differences, supplier input, compartmentalization, design for assembly, product demand data	Several years (Based on product life-cycle)	High.
Strategic Network Design and Optimization	Number, capacity and location of production plans, suppliers, warehouses, retailers. Decision on transport resources.	Few months to few years.	High.
Supply Chain Master Planning	Production, distribution, and transportation strategies	Weekly to monthly	Medium
Operational Planning	Inventory levels, transport, production	Hourly to daily	Low.

Another way of thinking about SCM and how it relates to transportation is to consider how a firm's competitive strategy correlates to supply chain trends. One such categorization is shown in Table 2-2.

Table 2-2 Schematic Influence of Competitive Strategy of Firms and Supply Chain Decisions
(Source: Byrnes (21)– adapted by author)

Influence	Type of Competitive Strategy		
	Innovation	Service Differentiation	Cost Leadership
Goals of SCM strategy	Fast Distribution	Product Availability Quick Response	Efficiency Balancing availability with cost
Inventory	Low to begin with but without hindering availability Ideally flexible manufacturing capacity	Relatively high safety stock or low order lead-times Spread near customer	Low safety stock
Transportation Policy	Air Freight Direct Delivery	LTL	TL, Rail, Sea
Facility Network (warehouses)	Minimal	Extensive Multi-echelon	Centralized

Having introduced the concepts of Supply Chain, in Chapter 3 we proceed to discuss the concept of Regional Strategic Transportation Planning (RSTP).

3 Regional Strategic Transportation Planning

Chapter 3 presents an overview of regional transportation planning practices. Having discussed the advances of contemporary logistics and the parameters that influence the design of supply chains in Chapter 2, this chapter acts as the second stepping stone towards understanding the connections between the supply chain management private sector strategies and the regional transportation planning as conducted by the public sector.

3.1 Definitions

Transportation planning, in its generic form, is a process that begins from understanding the current (and future) transportation needs of an area and provides ways to meet those needs in an effective manner. Transportation planning had traditionally been concerned with infrastructure building and maintenance, but it more recently also includes operational aspects and measures to improve transport flows like Intelligent Transportation Systems (ITS) as well as demand management techniques like pricing.

The adjective *strategic* in transportation planning produces four associations for the process: firstly it stresses the linkage of transportation with the overall development plans of a region – its economic, environmental and social state; secondly it implies a systemic view of the transport system where all modes are considered in the development plan as links rather than units or worse adversaries; thirdly, it implies a long-term general plan view rather than a short term project-specific one; finally, because of the intricacies created by the interaction of the above, the importance of institutional issues emerges and potentially creates another level of planning for institutional change.

Lastly, the term *regional* sets the boundaries for the process. Conklin and Sussman define regions as “functioning economic entit[ies].” Regions can be bounded differently on various levels: geographically they can be limited by physical barriers, politically by borders (international or intra-national), economically by the level of interactions among urban centers. For each of these cases there are in turn levels that influence the actual geographic area covered by the region. For transportation all these perspectives of regions are pertinent. In this work we will refer to regions that comprise a metropolitan area, a whole nation, or even clusters of nations. A region’s geographic extent is usually confined within an area of 500 miles and may include one or more metropolitan centers, several smaller cities and rural areas. Although a region may indeed cross political borders, the level of government cooperation is critical for any successful regional planning.

Any planning endeavor when it begins has to identify its targets. For the purposes of the discussion in this work we will distinguish between goals and objectives, using the definitions of Stopher and Meyburg (1975) as quoted by Ogden (25):

“**Goals** [are] idealized end states towards which a plan might be expected to move; [they are] the *desired eventual states* of a planning process. [**O**]bjectives are operational statements of goals, *measurable and attainable*.”

3.2 Framing Transportation Planning

Regional Strategic Transportation Planning (RSTP) deals, by definition, with complex and open systems. There are very few real-world examples where comprehensive RSTP, as described in the previous section, has been implemented. This occurred partly because of the complexity of the problems, and partly because the planners' agenda was politically and/or technically biased for one or the other solution. The whole issue of unintended consequences looms large when someone examines the past attempts to transportation planning on a large scale, as Box 3-1 points out.

Unintended
Consequences
and Planning

Box 3-1 The US Interstate Highway system

To take an example from within the US, *interstate highways* were founded by President Eisenhower in the mid-1950s mainly as a means for military mobility. This project soon shaped both the passenger and freight mobility patterns, creating an automobile/truck culture. Freight transport's need of reliability and accessibility at a low cost could be served by trucks rather than rail or waterway and this reinforced the tendency to invest in highway infrastructure. The modal shift, seen in Figure 2.1 with the decreasing share of rail and the increase of the share of truck, continued until the point where the demand for highways exceeded capacity and congestion phenomena that disrupted the freight transport flows became more common. Rail freight traffic started to rebound after 1985 but this did not necessarily include high value goods.

At the same time, the comparative inefficiency of truck in terms of ton mile capacity per gallon exacerbates another set of consequences that is environmental in nature, with increased emissions per ton of freight moved. Characteristically, Figure 2.2., shows that in 2000 while trucks hauled 34% of total ton-miles they used 700% more fuel than rail that hauled 46% of total freight miles. Of course their purpose is different but still this difference is indicative.

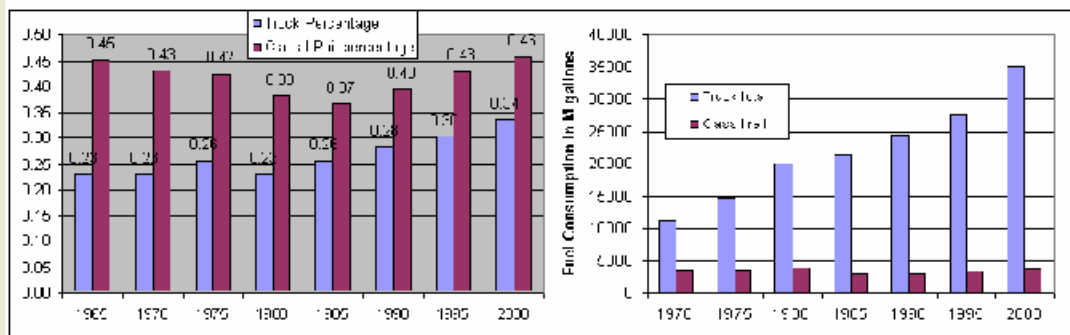

Figure 3-1
 (left) Ton-miles carried by rail and highway as a percentage of total (excluding pipelines) --
 (right) Actual fuel consumption of each mode. [Data source: BTS (2001)]

The breadth of consequences from transportation related decisions, which are only schematically illustrated in Box 3-1, highlights the significance of a clear set of goals and objectives for the planner. At the same time, the whole issue of dealing with unintended consequences and planning

for complex systems has evoked various approaches that share a common systemic or holistic viewpoint. In the first half of this section, we will initiate the discussion for establishing a set of goals and objectives for the planning process, describe briefly how it fits with the current general regional planning literature, and we will present the various methods that have been used or where proposed for use in comprehensive regional strategic transportation plans.

3.2.1 Discussing the policy goals

The definition of goals and objectives for transportation planning can be deceptively straight forward: a plausible goal could be *the provision of a reliable and cost-effective transportation system that will have adequate capacity to serve the transportation needs of a region for the planning timeframe*. In this sub-section we raise the issues that become important when considering transportation planning.

Since the transportation of freight is a derived demand (as discussed in Chapter 2), the demand for a system that is capable of transporting freight is also derived and hence, the capacity of such system has to approximately match the current or anticipated demand for freight. This leads Hicks (1977) as quoted by Ogden (25) to describe the same vision transformed to fit the freight transportation sector, but highlighting the importance of reduction of external costs or “disbenefits.” In Hicks’ words:

[The goal of freight transportation policy planning is] the discovery and effective implementation of measures which will reduce the total social cost of goods movement to the lowest possible level commensurate with the freight requirements and objectives of society.

Raising the level of complexity, Hall and Sussman have argued that sustainability cannot be ignored in the agenda of transportation planning. They indicate that the pursuit of a sustainable transportation system (a goal aligned with Hick’s definition) is not sufficient; the transportation system’s connections with the other sectors have also to be investigated for sustainability. As they describe it:

“Of particular interest is the sustainability of the transportation sector itself, the relative sustainability of all sectors, and the connection between sustainable transportation and sustainable development in a global context.” Sustainability

Sustainability incorporates three aspects: economic, social and environmental and thus Hall and Sussman’s argument supersedes the considerations of another set of planning approaches that originate from the *regional development* school of thinking. These planners consider transportation as means for economic growth. It was not uncommon policy for the U.S. Department of Transportation to attempt to gain support and federal funding for transportation infrastructure projects by providing data on the projected economic growth and increases in employment that the said projects were expected to create. Economic growth

The goals tend to become a lot fuzzier when the transportation system is regarded as a vehicle for extended economic growth. Academic circles have been divided on the extent that such effects should be expected and no conclusive answer has been proposed. The consensus is that transportation infrastructure is necessary but not sufficient and its mere existence does not

guarantee growth.²⁷ In any case, the transportation sector's contribution in the economy by itself is significant; according to BTS (2003) for-hire transportation activities in the US contributed 3% of the country's GDP in 2001 (1.2% trucking and warehousing, 0.8% air, and 0.4% rail) while if we consider transportation final demand, that is all activities that were related to transportation,²⁸ this contribution reaches to 10.4% of total GDP.²⁹

Economic Development and Regional Competitive Advantage Economic development is another objective within the economic realm. Yet it requires a different more systemic line of thinking and is more closely related to the SCM/RSTP issue of this thesis. For this reason, Chapter 4 provides a detailed discussion of SCM impacts on economic development and how this can be promoted by an efficient, well-planned freight transport network.

Decoupling Interestingly enough, in accordance with the sustainability framework there has been a discussion, started by the European Union, of "decoupling" transportation and the economy. Decoupling implies a reduction of transportation intensity. For freight transport this would mean that the growth of the GDP should be independent or at least not heavily correlated with ton-mile growth, or some argue simply with the emissions from the sector.³⁰ Part of the decoupling success is based on the "dematerialization" of the economy where the weight, volume, and quantity of goods is being reduced while their value is increasing. Electronics is the textbook example of "dematerialized" good, while increases in the services sector output may also produce a dematerialization effect.

Safety Security Resiliency Beyond the direct transportation contribution to the economy two other important factors gained special prominence after the events of 9/11: (i) the centrality of transport in the national economy and (ii) its ubiquitous characteristic. Disrupting events, either intentional or accidental, may have significant repercussions and initiate a snowball effect with high economic costs, while at the same time the convenience and ease of freight transport may be used against society by for example, smuggling weapons or "dirty bombs."

It is apparent from the above discussion that the policy goals of transportation planning can vary substantially. Putting the pieces together, general transportation planning decisions would heavily depend on: (i) the transportation context of the country; if it has a sufficiently developed infrastructure network like the US or if it is still developing it like India; (ii) the overall policy perception; if for example sustainable development is on the political agenda or not or if there is a vested interest on public transit and passenger facilities which can appeal to voters better than let's say, sophisticated port equipment because the latter is not directly visible; and (iii) the economic condition of the country; i.e. if there is available funding for investment from internal

²⁷ For a more detailed discussion of the relationship of transport and economic growth see Chapter 4. See also Polenske (27) and Lakshmanan and Anderson (28).

²⁸ Transportation final demand index includes government investment, fuel, vehicles, parts, maintenance services etc. For a more detailed description see Dieckmann (2002).

²⁹ An anecdote that shows the subjective and fluid estimates of impact of transport on growth comes from the benefit cost analysis concerning the Central Artery Project in Boston, MA also known as "Big Dig." Advocates of the project considered the labor and some production expenditures of the project as an infusion to the Massachusetts economy and therefore a benefit while their opponents considered the same expenditures as costs and expectedly came up with entirely different conclusions.

³⁰ It has been claimed that the US economy may be closer to the decoupling point than the EU. Unfortunately, this rationale does not seem to take into account the total flows from raw material to final product and it disregards international shipments. In effect this means that the US or the EU economy may look dematerialized but in effect the transport has been transferred on the sea and in the producer country (usually in Asia). I would propose that dematerialization indexes are only meaningful in a global context.

(economic surplus) or external sources (international borrowing or aid). In the latter case the goals of the planners will be influenced by the lenders' objectives, the most prominent being World Bank.

For this thesis, we will use the following working definition of transportation planning goals focused on freight transportation issues that combines Hick's and Hall and Sussman's approach:

The freight aspect of a regional strategic transportation plan should ensure (i) an adequate, efficiently operated, robust, and secure transportation network based on (ii) a regulatory structure that in coordination aim to maximize total societal benefits within a sustainable framework.

Maximizing total societal benefits as opposed to minimizing total externality costs is one of the "lessons" that can be derived from the private sector's approach to an integrated supply chain. Total societal benefits represent the balance between the advantages from economic growth (similar to the profit function of firm) and the externality costs (that are analogous to the costs for a firm). An initial example of how this paradigm can be applied to freight transport planning is presented in Box 3-2.

Box 3-2 A schematic example of how minimization of transportation externality costs will not create the optimum sustainability outcome

The EU has in place product life cycle regulations that require the re-use and recycling of automobiles and electronics. The requirements will be enforced in stages and they intend to (i) reduce the potentially hazardous toxic materials from ending up in landfills and (ii) create an incentive to exploit those same articles as potentially precious raw materials (or nutrients).

At the same time legislation for road pricing is being introduced independently and truck traffic is being targeted first. The intention of the legislation is to create an externality costing mechanism that would rationalize the use of the infrastructure.

The two legislations put together operate antagonistically by possibly increasing prohibitively the cost of collection at the end of the product's life. This will not raise the acceptance level for the new legislations and further decrease any cost advantage that may be gained from re-use of materials to the firms. It may increase the probability for legislation evasion and decrease the internal initiatives of re-use that are not mandated.

An alternative approach could involve the reduction or even negation of road pricing for trucks that pick-up and transfer materials for recycling.

The example above illustrates one final point regarding the effect that general regulatory policies have on transportation and how they interact with transportation planning: policies outside the immediate realm of transportation have profound effects on transportation flows. The next section introduces the policy issues that influence transportation flows and especially supply chains but are not directly associated with transportation.

3.2.2 Policies that influence supply chains and freight flows

The set of end-of-life regulations described in Box 2.2 is just one example of regulations that can alter transportation flows while not having to do directly with transportation planning. This is an important initiative for supply chains especially, since it affects the raw material location and creates an intense need of total product life cycle supply chain that is close to the “sustainable supply chain” definition in Section 2.4. Supply chains though are also influenced by a host of other policies. These are summarized in Box 3-3 as the most important areas where public policy decisions affect freight transportation flows and supply chains. They range from the traditional perspective of infrastructure building, like the creation of a new port facility or the upgrade of an existing highway to the indirect incentives of profit taxation and import duties that affect decisions on industry relocation.

Box 3-3 Set of public policy decisions that influence supply chains

- **Transportation Infrastructure building:**
 - Conventional infrastructure
 - Tolls
 - Transportation Operations
 - Information Systems and geo-coding
- **Regulation:**
 - Product and Process Regulations (Regulation of Items transported)
 - Local Content Requirements (important in terms of transport but free trade agreements are reducing their extent)
 - Performance-based standards (safety, emissions, composition – can dictate the import of one product over another)
 - Basic Standards and Design specification (ISO, TUV,CE)
 - Labor and Manufacturing Process regulations, including manufacturing emissions (potential for relocation of facilities)
 - Transport Regulation
 - Safety regulations (for trucks: weight, driver rest etc and similar for other modes)
 - Emissions requirements (air pollutants and noise)
 - Rate and market regulations (most modes tend to be deregulated but there are still cabotage laws for shipping)
 - International regulations in terms of Free Trade Agreements influence the existing policy options.
- **Taxation**
 - Taxes on industry profits (potential for relocation of facilities)
 - Import duties (usually tied to Local Content requirements)
 - Taxes on the use of the transportation network (fuel, emission, or ton-mile taxes)
- **Subsidization**
 - Direct subsidies
 - Indirect modal subsidies (e.g. preferential taxation)
 - Research and Development grants
- **Development Strategies**
 - Industrial clusters and zoning
 - Supply chain centers (e.g. freight villages and the Zaragoza project)
 - Free Trade Zones
 - Identification of “national champion” industries

Regional strategic transportation planning, as defined in the first section of the chapter, encompasses the areas above that directly affect transportation. While a regional strategic transportation plan should be aligned with the objectives of any pre-existing regional economic development plan and react to the consequences of other the other policies, all these areas cannot be included in an RSTP.

This thesis by identifying the connection between RSTP and SCM concentrates on the transportation-specific areas that comprise the public sector's policies. Although in some case studies we will also touch upon their alignment with the overall regional development plans as well as their connection with international issues, the main focus of the work will be on transportation-specific policies.

3.3 Methods and Frameworks for RSTP; State-of-the-Art

After defining RSTP and having framed the discussion, in this section we will present the approaches to RSTP as exhibited in the transportation plans of the U.S. and Europe as well as the frameworks developed up to now in the academic environment and specifically at MIT.

3.3.1 Transportation Planning in the U.S.

Ward (29) has investigated extensively transportation planning in the U.S. and hence this section mainly provides a summary of his findings.

The U.S. does not have a unified approach to transportation planning across the fifty states. The size of the U.S., a relative degree of autonomy among states, and differing needs and political mandates create an environment that as one would expect is prone to diversity. This indeed is the case; as exhibited by the example of Box 3-1; the extremely significant infrastructure investment in the U.S. highways that provided the country with a significant competitive advantage had to be promoted as a military need in order to circumvent the constitutional mandate that allowed states to deny interference from the Federal government when this did not conflict with interstate trade.

Comparatively
Weak
Centralized
Control

Things have evolved since the mid- twentieth century with the emergence of new interstate regional organizations.

The transportation plans that Ward identifies are:

- **The Long-Term Regional Transportation Plan.** This is a five-year plan developed by the Metropolitan Planning Organization (MPO) with a planning horizon that exceeds twenty years. The plan combines programs that are desired in federal and state level with input from local jurisdictions. It is mainly infrastructure-oriented and is restricted financially by fiscal projected funding. This program is the one closer to strategic RTP due to its long-term outlook and can consider interactions with non-transport areas like land-use, environment and the economy.
- **Medium-Term Infrastructure Plans.** The medium-term plan called Transportation Improvement Plan (TIP) bridges long-term planning and actual construction. The TIP's outlook is longer than three years and is updated every two. It is a commitment to fund some of the more important projects outlined in the long-term plan which brings them closer to implementation.
- **Operations Strategies.** Also known as Regional Concept of Operations, the operating strategy coordinates agencies towards regional goals as described by FHWA (31). They can be considered as precursors to institutional architecture.

- **Regional ITS Architectures.** This concept was introduced in order to facilitate interoperability of technological systems that are implemented across different jurisdictions. This is ensured by promoting the adoption of technologies that satisfy common federally adopted standards. These standards were set with a wide enough range of specifications in order to avoid stifling local requirements. The planning horizon of the ITS Architectures plans as proposed by the U.S. DOT varies from 5-20 years (7). The LRTP of a region will guide the choices for services and systems within the ITS plan while the ITS plan can provide feedback on implementation effectiveness for the next iteration of the LRTP. ITS Architectures can also be developed through cross-jurisdictional cooperation as indicated in (32).
- **Strategic Plans.** These plans are not required by the U.S. DOT and so they have no formalized structure. They have a broader scope compared to the TIP and LRTP plans since they are not necessarily project-oriented. State DOTs have developed these with a variety of objectives and planning horizons.
- **Business Plans.** These are short-term plans that aim to transcribe the strategic plans into day-to-day operations.

Overall, we can say that the US transportation planning process has taken the right path with regard to calling for cross-jurisdictional cooperation, technological inter-operability, and strategic planning that may be outside the strictly transportation focus. As we shall also see in Chapter 5, these trends have not yet fully blossomed in practice where a project-oriented mentality is prevalent and the systemic view is not emphasized enough mainly because it is hard to tackle both as a political proposition as well as a research one.

3.3.2 Transportation Planning in Europe

EU General
View

While the U.S. has been notable for the development of structured planning processes, the European Union relies on more project specific individual planning processes. On the other hand EU's stated long-term goals have been significantly influenced by the sustainability agenda.

This latter trend may be partially explained by the fact that the European Commission, unlike the U.S. Federal government, is not a directly elected governing body; instead it comprises the representatives from individual member countries and as a result the concerns over popularity of measures and accountability are blunted. The individual transportation policies of member countries can vary significantly and compliance with the centrally assigned goals may be deferred when they are conflicting with local public sentiment (or for that matter influential local lobbies). This trend is enhanced by the principle of subsidiarity (that is the assigning of power to the lowest possible level of government able to handle a certain matter).

The main driving document for transportation planning has been the White Paper for common transport policy: "*European Transport Policy for 2010: Time to decide*" (46). It is notable for the ambitious sustainable agenda that it promulgates but also for explicitly referencing the need for comprehensive policy planning across the board³¹ which aligns very well with the arguments raised in this document. The planning process can thus be characterized as top-down; the goals and general guidelines are set on the highest echelons informed by research projects.

³¹ On page 15 under Section V the relevant areas are identified as: economic policy, land-use planning, social policy, urban transport policy, internalization of external costs, opening of markets (de-regulation), and transport research.

Initially the Commission produces a paper of intent and discussion without recommendations (*green papers*). Then research projects are delegated to groups of academic institutions and independent consultancy firms that have competitively bid for them. Based on those recommendations as well as on input from member countries an official set of guidelines and larger goals are described along with recommendations (*white papers*). For specific regulatory issues, the Commission issues directives (*Eurovignettes*) that have a specific timeline to be incorporated into laws of the member countries.

EU Planning
Process

Member countries and municipal governments in their turn develop proposals that relate to one or more of the guidelines in the white papers and submit it for funding approval to the Commission's appropriate bodies. These proposals are ranked on a set of criteria which mainly rate the project's contribution to the goals of the white papers and its fit to the EU-wide projects. Funding from the Commission is matched by private or municipal funding in most projects. For projects deemed strategic, like those part of the Trans-European Network (TEN), the Commission subsidizes the greater part of the budget.

3.3.3 Transportation Planning Frameworks: evolution in the MIT Perspective

As we have seen in Chapter 1, technology was a key driver in the developments of the modern supply chain and it is evident that it plays a similar role in transportation planning. Conklin and Sussman (2000) summarize this influence succinctly:

“[Intelligent transportation systems] ITS has enabled transportation system management and control on a regional scale by facilitating the transmission and processing of transportation system data at a level that was impossible just a few years ago. *This data collection capability has allowed system planners and operators to view the system in a more integrated manner encouraging a much broader geographical perspective.*”

For this reason a planning process that was designed specifically to incorporate the technological advances in transportation planning becomes important. The Regional Strategies for the Sustainable Intermodal Transportation Enterprise (ReS/SITE) framework is the outcome of an MIT research project that outlines a transportation planning structure on a regional scale that incorporates sustainability and intermodalism. This section presents a summary of ReS/SITE; more details can be found in Conklin and Sussman (2).

The ReS/SITE framework is initiated with scenario development. Different future images that have a rational explanation and are based on current data are created in this first step. These are based on the central issues that the planners face and will be used to form and test the proposed strategies for robustness.

The second step involves the determination of the region's strategies. This step has more to do with setting the objectives and priorities rather than deciding on specific projects. The end product of this work is the *strategic plan* that defines the long-term strategy of the region with a five to twenty year planning horizon. The strategic planning comprises two main components: *infrastructure and architecture*. Pendleton (2000) quoted by Conklin and Sussman (2) summarizes: “[T]he regional architecture and regional infrastructure are complementary documents. Both support the deployment of services – one from a physical standpoint, and the other from an institutional standpoint.”

The infrastructure component is the more prominent one since it relates with major projects and equally significant budgets. The processes of deciding among proposed projects, finding funding, and bidding to constructors are more or less known and have been performed adequately albeit with the necessary improvements and changes.

The architecture component is comparatively more recent and has its roots in the deployment of intelligent transportation systems (ITS) in a manner that ensured interoperability. Broadening the concept of architecture, the ReS/SITE framework, proposes the creation of a *regional architecture* that identifies and modifies accordingly the institutional, operational, and informational structures that make transportation decisions within the region. The older ITS part of regional architecture deals with the technical implementation; it starts with what is required by the customer (*User Services*) and proceeds through the *Logical Architecture* to define how those requirements will be met, that is with what activities, technical systems, and functions. The second level of the regional architecture defines the responsibility and functions of the institutions that manage transportation issues in the region and the lines of communication amongst them. This way, the regional architecture bounds and coordinates the decision making process. Finally, going beyond infrastructure means that regional architecture should be adaptable to new operational needs and requirements as they appear. It is evident that on this level the issues may become *politically sensitive* and charged especially if the region's transportation has been managed previously by existing organizations. It is reasonable to expect that the incumbents would react and deny change when it means the empowerment of another organization, the assumption of responsibilities that were traditionally theirs, or even their dispersal.

Following the ReS/SITE framework the CLIOS process has been also proposed for use in transportation planning. Since this thesis is analytically based on CLIOS, a more elaborate presentation of how the process can be used to carry out general transportation plans for a region is entailed. In Chapter 4 we bring SCM and RSTP together and discuss how and to what extent they relate to each other from a theoretical perspective.

4 Interconnections between Supply Chain Management Practices and Regional Strategic Transportation Planning in the Existing Literature and Practice

Why should governments and companies be motivated to cooperate on SCM and RSTP?

This chapter provides a first approach on the interests of the public and the private sector and how they interact with respect to freight transport and planning for it. The discussion is based on critically presenting the pertinent literature. The first part of this section is devoted to discussing the *theoretical* perspective of how SCM actually interacts with regional development and the second part is presenting *practical* experiences from logistics projects, policies, and policy recommendation reports.

4.1 SCM Influence on Regional Development (Theoretical Discussion)

4.1.1 Regional Economic Development

Improvement of the economic conditions in a certain region is an appealing theme for transportation planners. Although, in the U.S. the Metropolitan Planning Organizations (MPOs) only moderately embrace responsibility for economic development, infrastructure development proposals are often backed by estimations of impacts on economic growth. It would be helpful here to define and distinguish growth and development (Vaughan and Bearnse (1981) cited by Grube (38) pg. 56):

Economic development constitutes a *qualitative* change in the existing configuration of the regional economy that comprises innovations, institutional changes, individual behavior etc. **Economic growth** is a *quantitative* expansion of the economy in terms of investment, output, consumption and income.

Growth and development maybe linked and usually when one of the two terms is used the other is also implied. Either economic growth or development of course is pointless if it does not contribute somehow to improvements in the quality of life of the region's population. The indicators for such contributions are increases in employment and disposable income for the citizens as well as in the revenue streams of the regional government.

Box 4-1 A discussion of regional competitive advantage and cluster theory

As we have seen in Chapter 1 the management of supply chains provides a key, and in some cases *the* key, competitive advantage for companies. Michael Porter in “Regions and New Economics of Competition” indicates that “while having good roads, a sensible overall tax policy, and intellectual property protection are all important to a productive economy, then the *defining sources of competitive advantage are often more specialized.*” It is reasonable to expect that countries with competent transportation infrastructure will fare better in terms of growth compared to countries that lack such facilities. At the same time it is unreasonable for a country’s leaders to expect that their infrastructure advantage over their developing neighbors can be retained in the next decade – such a notion would be equivalent to a trucking company that has bought faster trucks and bases its competitive advantage on them. It is obvious that other areas of competitive advantage should be sought after. We argue that public private partnerships that foster efficient supply chains can offer to the host region an area of competitive advantage.

Porter describes the transition to the new economics of regional competition as revolving around the following six individual transitions: (i) from a macroeconomic to a microeconomic approach, (ii) from productivity growth to a capacity to innovate, (iii) from economy-wide policies to clusters, (iv) from internal to external company success, (v) from separation of economic and social policy to integration, and (vi) from national to cross-national, regional and local focus of attention.

Porter argues that natural resources do not determine competitiveness and prosperity of a nation on a global level but rather the productivity which the enterprises that operate within it can achieve. Productivity is the only quantifiable measure of competitiveness and Porter claims that productivity should be considered not only through efficiency - with the common definition of output per labor-hour - but also in terms of the product value (i.e. in uniqueness, quality, features etc). SCM is exactly such a productivity increasing tool. “*Prosperity has less to do with what an economic area produces than how it goes about doing so.*” Nations can have the traditional comparative advantages; that is a nation’s opportunity costs of producing a certain product is less than that of another nation due to concentration of natural resources¹ for example. But Porter argues that these play a less significant role in the conditions of the new economy. The competitive advantages that a region or nation can exhibit, that is their ability to add value to a product is important.

Porter’s cluster theory differs from traditional industrial policies by the fact that it considers *all* developed clusters as contributing to prosperity whereas the traditional view anticipates the creation (and subsidization) of national champions¹. According to Porter, government’s task should be “to improve the business environment to allow existing and emerging clusters to be more productive.”

Continues on the next page

Continues from the previous page

Of course, different regions have different strategies and different areas of comparative advantage which may prioritize different types of freight movements. For example, a region that relies heavily on tourism will prefer to keep heavy industry activities invisible and the freight needs will be focused mainly in catering the visitor's needs quickly and with the least intrusion. Regions relying on services need easy and fast access for express parcel shipments that are characterized by low volume and high priority. The higher priority efficient passenger system for those regions is in general able to accommodate the low volume freight needs in parallel.

Grube (38) discusses extensively the connection of the cluster - based economic development strategies and transportation planning. He introduces a framework (pg. 155) that progresses from the identification of the regional clusters, their development phase and dimensions, to the cluster transportation needs and a final evaluation analysis to prioritize transportation investments. His framework approach focuses equally on the passenger needs for personal network interactions to occur to support the cluster creation and the freight needs of the cluster but in the examples and case studies, freight is assigned a support role.

The cluster concept emphasizes the co-existence of a variety of related institutions (components) of which the specialized infrastructure providers are one. When it comes to industries that are transportation intensive the SCM component is thus becoming important even when it comes to the other components of cluster success (networking, innovation, knowledge-sharing etc.).

One of the main contemporary theories of industry location is cluster theory as formulated by Porter (1992).³² Porter has also transferred his insights on the competitive advantage on the firm level to discuss competitive advantage on the regional/national level (Porter (37)). Box 4-1 presents a discussion of Porter's views within a transportation planning context.

Summing up the economy argument, the regional authorities anticipate (i) the attraction of new and establishment of current industries within the region, and (ii) increasing the productivity and hence competitiveness of the incumbent industries. This affects the transportation plans of regions that have or aspire to have significant volumes of freight and material intensive industrial and retailing sectors.

4.1.2 The private sector perspective: competitive positioning in the global and regional markets

As extensively discussed in Chapter 2, supply chain management (SCM) is the control of product and informational flows from the source of raw materials to the end consumer based on coordinated relationships with both suppliers and retailers. It is an innovative reaction of private sector firms to changes in their competitive environment. These changes can be roughly described

³² Porter's theory follows a tradition of several location theories that include: the growth pole theory (Hirshmann (1950), the central place theory (Losch and Christaller overviewed by Parr (2002)), the network theory of innovation etc.

as interactions of push and pull events. Pull events are those that provide the means for effective SCM to take place: (i) advances in information and communication technologies (ICT) that allow for electronic data interchange (EDI), shipment tracking using global positioning systems (GPS) or radio frequency identification (RFID) tags, and business to business (B2B) or business to consumer (B2C) networks; (ii) advances in operation research methods including simulation models that allow for optimization of complex operations in conjunction with easily obtainable computing power; (iii) increases in efficiency and capacity of transport modes along with the liberalization of freight markets that reduces transport costs; and (iv) liberalization of international trade that reduces the transaction costs for cross-border interactions. Push events, on the other hand, create a Darwinian environment in which firms are forced to adapt or perish and these are mainly results of market competition: firms are competing in price, in product line variety that increases consumer choice, and customer service.

On the micro level, this environment challenges firms to obtain the skills that allow them to remain competitive by taking maximum advantage of external economies and thus balance network, agglomeration and dispersal economies in a close to optimum way. In a similar manner, on the macro level, this environment creates highly competitive conditions for the regions on a global scale. Globalization of suppliers and buyers allows the extension of industry cluster boundaries over expanded geographic areas. Essentially there is a trade-off: the opportunities for the region's factors of production to be utilized are increased by the participation in expanded-global markets and so are the choices offered to resident consumers but on the other hand traditional protective barriers are raised and comparative advantages of other regions become more pronounced.

4.1.3 Regional Economic Development and SCM: an ambivalent relationship

The question that is raised on the macro level of the region is whether it is possible for planners to incorporate or promote SCM practices and thus increase regional competitiveness as implied in Section 3.1.1 or if SCM is just a tool product of increased competition that is essentially regionally neutral as described in Section 3.1.2. The following paragraphs present arguments from the relevant literature as well as ideas about how regional strategic planning can be effectively employed that will be developed in the following chapters.

Literature Review on regional effects of supply chains

Glasmeyer and Kimbler (39) emphasize the effect that SCM practices have on warehouse location: distribution centers tend to consolidate and locate to the fringes of urban cores. This tendency facilitates economies of scale, reduces inventory based on risk-pooling and EDI, while retaining or increasing customer service levels. They also note the emergence of massive retailers, like Wal-Mart, and the almost monopolistic market power they wield based on their ability to "homogenize demand at the level of the nation." (pg. 756) Fishman (18) notes the lack of academic research on the Wal-Mart phenomenon and their ability to "squeeze" the profit margins of their suppliers. Wal-Mart can transfer their production orders of any single commoditized product from the U.S. to China with ease if the national producer is incapable of conforming to their requirements. In this case, SCM is shown to weaken the advantage of one region (internal US production) for the advancement of another.

Polenske (27) studied the effect of transportation policies on the metalworking industry in Chicago and found that commodity producing firms are more susceptible to policy changes as opposed to firms that produce custom parts but overall the industry does not consider logistics vital for its operations. Li & Polenske (40) note the existence of dispersal economies based on

their observations of three sector case studies: the metalworking case discussed above, the coke-making industry in China, and the multinational expansion of the Haier Group, a Chinese based electrical appliance manufacturer. They note that the coke-making industry benefits from dispersed plants because of proximity to suppliers and consumers, and because of environmental advantages peculiar to smaller scale operations. The Haier Group reaps dispersal economies for its global scale operations by consolidating their distribution center (DCs) operations close to major metro areas in Europe and the US and increasing service levels via EDI practices.

SCM as tool for Strategic Advantage

The above discussion indeed implies that SCM has only an *incidental* effect on regions; it is rather a tool that allows centralization and decentralization to happen with equal ease according to the economies of the external environment. What SCM achieves is to increase the decision space of firms; it creates efficiencies of centralization or decentralization and thus allows firms to choose the strategy that they expect it will offer them *strategic advantage*. Two other textbook examples of successful SCM in the current literature emphasize this point: Dell, the computer manufacturer, and Zara, a European mass-fashion industry. Dell does not have one location center; it has a number of assembly plants devoted to large geographic regions and uses internet B2C applications to fill orders that are consequently transferred to those regional assembly lines. Dell outsources all computer parts to original equipment manufacturers (OEM) - mainly third party firms in E. Asia - and assembles the customized order based on those “gray” parts. Their transportation costs are high but they are more than compensated by the reduction of inventory costs in the very high turn-over computer industry. (Simchi-Levi, et al. (13) pg 229 and 237-238). Zara faces the same problem, i.e. volatile customer demand and highly depreciating product, uses the same idea of mass-customization but with a slightly different locational outcome. Zara produces approximately thirty percent of its product line ahead of time and supplies only their own store chain. This allows for outsourcing this demand in low-cost manufacturers in Asia, Latin America and Eastern Europe. When the first consumers make their buys the trend of what is going to be worn in the season is identified, then production is pumped up mainly in their centralized facility in La Coruna, Spain which is located relatively far from the traditional fashion centers (Freiman and Mendini (2002) and Dutta (41)). These highly successful companies in two different sectors are heavily utilizing overseas outsourcing to respond to forecasted demand and at the same time retain local capacity in terms of final assembly for Dell and full manufacturing for Zara to respond to spikes in the actual market preferences.

On a first approach the question that we set to answer seems to lead to an ambiguous answer: supply chains are a flexible tool that allows for integration of production lines and cooperation of regions across geographical borders. They can create in effect *virtual* clusters that do away with the need of local proximity. Landsberg and Burkett (42) touch upon the negative aspect of this effect of SCM implicitly, when criticizing the “flying geese” theory that was coined to explain the Asian economic “miracle.” They point out that the East Asian economies are closely tied to the Japanese economy in a core-periphery relationship.³³ The industries that spring up in the periphery as a result of export-oriented policies combined with foreign direct investments (FDI) originating from the core tend to be tied to the parent companies. SCM facilitates this connection by allowing import of tools, materials and parts as well as the re-export of the product to the expense of locally developed suppliers that are thus out-competed. The results of this type of virtual clustering are reminiscent, albeit more complex, with the effects of export-oriented

³³ The core-periphery scheme extends from Japan as core, to the Republic of Korea, China/Hong-Kong, Taiwan, Singapore as peripheral countries that become “Newly Industrialized Economies” or NIEs and in turn direct foreign direct investment (FDI) to countries like Malaysia, Thailand, Indonesia etc.

agriculture: intensive uses like coffee plantations and meat-raising farms prohibited the cultivation of local food supplies in developing countries leading in extreme cases to famine.

Given the above discussion, how can SCM actually be harnessed as a competitive advantage for a region in the sense that Porter (2001) describes? Of course it is expected that where corporations with international ties establish facilities there are transportation network connections. This raises a whole set of questions: do networks differ by region and what is the differentiation in scale and scope that is actually required to make one network more advantageous for the needs of firms? Could the innovation generating SCM be used in a way that creates a long-term asset and if this is possible what are the caveats and important policy considerations?

SCM as regional competitive advantage

As discussed in Box 4-1 Porter (37) emphasizes the fact that a regional competitive advantage cannot be based solely on transportation infrastructure and a reasonable tax policy. Polenske (27) cites different studies that lead to different deductions on the economic effects of transport infrastructure. Even if the above arguments are true, competitive supply chains cannot achieve transport cost minimization and more importantly cannot reduce in-transit inventory and allow just-in-time (JIT) manufacturing if there are significant bottlenecks in the system. As a result, we argue that a comprehensive transportation system that addresses bottlenecks and provides effective operational policies is prerequisite for retaining a regional competitive SCM advantage. For example, the Alameda Corridor project, a freight rail artery that connects the Port of Los Angeles to the rail network avoiding highway traffic conflicts by grade separation, is a project that retains the advantage of fast freight intermodal connections in that region of California. At the same time, since SCM relies so heavily on ICT, the provision of adequate bandwidth cannot be overlooked.

Infrastructure may be necessary but is not sufficient to ensure a sustained competitive advantage since all competing regions can sooner or later upgrade their facilities. On the other hand, location and incumbency are more difficult to challenge just by merit of superior infrastructure. So policies that create a first-comer advantage may be more likely to succeed. SCM can help in this respect since it allows the creation of markets from scratch. To put this in context, there are products that are not consumed in certain areas of the world simply because they cannot physically reach there. As a recent example, Osgood and Kennedy (43) proposed that developing a fresh tropical fruit export industry can be a strategic move for Malaysia; markets in the US and Europe are practically untouched since up to now there is no cost-effective way of transporting tropical fruit fresh because they cannot be refrigerated. If Malaysia succeeds in creating an efficient supply chain aided by biotechnology advances then Malaysians will initially gain a potentially lucrative monopoly that would probably allow them to retain brand recognition when competition catches up.

On a different level, the issue of a dearth of backward linkages because of an export-oriented model of industrial policies and FDI as raised by Landsberg and Burkett (42) creates legitimate concerns. They suggest that avoiding a periphery role for the developing region may be feasible if industrial policies focus on the needs of the internal markets and labor force as well. We believe that there may be ways to circumvent this problem on the SCM front in an innovation inducing clustered environment. First, as Simchi-Levi et al. (13) pg. 181 point out using the IBM personal computer concept, outsourcing can oftentimes lead to an advancement of the know-how and market power of the suppliers. Secondly, SCM being a still nascent concept allows room for further innovations.

On this front, the comparative evolution of the PLAZA project, a unique state-of-the-art logistics park in Zaragoza, Spain and the Port of Tanjung Pelepas (PTP) in Johor, Malaysia could provide researchers with interesting case study material of the two different approaches: the regionalized innovation-centered versus globalized, state-of-the-art and in competition with incumbents. PLAZA focuses on the provision of services mainly to the regional market and aspires to generate innovation by combining graduate research and education with practical applications (ZLC (44)). PTP on the other hand is a hub port created as a lower-cost competitor to Singapore and as hub it relies on the trans-shipment of international containers (PTP (45)). In a few years the difference in viewpoints will provide insights on the results of the different policies on regional competitiveness.

From another comparative perspective, the top five leading exporters among developing and newly industrialized economies (NIE) countries, are China, R. of Korea, Mexico, Taiwan, Singapore and Malaysia (World Bank data). If we exclude China and Mexico as special cases (the size for China and proximity to the U.S. for Mexico), larger countries like India, Brazil, Indonesia and Philippines are further down in the list. Can the difference in this export capacity be attributed to more successful transportation planning that facilitated supply chains?

The literature that bridges the gap from the firm level adoption of SCM to the regional level of planning is sparse. SCM is a tool that facilitates change rather than prescriptive for a certain type of regional restructuring. Different firms have used the same concepts in different ways but in general there is a trend towards centralization of warehousing and outsourcing of manufacturing. Based on this flexibility, we have argued that SCM allows planners to view the competitive advantage as a plus-sum game. Public-private partnerships can create innovative concepts like the PLAZA projects or simply state-of-the-art infrastructure focused projects like PTP. The jury is still out regarding these two examples but if the analysis presented above is correct PLAZA has more chances for a lasting success because it focuses on internal/regional consumption, it promotes clustering and innovation, and creates a new market niche.

4.2 Importance of Freight Transport for the Region (Practical Discussion)

The Niles MTI report (50) focuses on urban freight movements; it also describes several specific benefits to an urban region that come from freight mobility:

- Manufacturers and distributors obtain raw materials, parts, subassemblies, and complete products from distant sources.
- Firms consolidate production and goods distribution services to achieve economies of scale and sell to a larger market.
- Individuals obtain food, energy, construction materials, and other goods reliably at costs of time and money that do not discourage development and growth.
- Producers and individuals send and receive packages and other shipments of different sizes without excessive cost or time.
- Metropolitan areas grow larger and yet denser because economies in freight delivery support scale and density in public services, production, housing, and other economic sectors.
- Metropolitan areas can have lower density through easy transport of goods within the region.

These benefits are thought by those associated with the trucking industry to be under-appreciated in public deliberations about transportation investment. In Washington State, those professionals focused on maintaining freight mobility are fond of saying, “freight doesn’t vote.” A civic leader in Oakland, California lamented to a journalist, “I don’t think anybody in the position of decision making or anybody in the position of power has spent any time thinking about how goods are moved. They think goods get to Kmart in a taxicab.”

The regional authorities/ governments are representing and aim to best serve the needs and choices of their resident communities. This makes their goals and priorities politically sensitive and thus they are expected to differ from region to region as well as over time as the political mandate changes. Independent of priority though, the following concerns emerge as prominent: economic growth, employment, and environmental preservation, compatibility with other uses and residences, and catering community needs.

4.3 Experiences in Integrated Policies for the Transport of Freight

4.3.1 Freight Related Transport Policy Reports and Recommendations

In this section, we present and discuss in brief the findings, recommendations, and insights from academic and policy reports that involve freight transport, sustainability, and transportation planning. The reports come from a variety of sources although the U.S. and Europe dominate in their production of relevant material. This literature review is not intended to be comprehensive although effort has been given in discussing the most representative reports.

4.3.1.1 The Mobility 2001 Report (51)

We begin the presentation of related reports with the Mobility 2001 report because of its comprehensive scope, its introductory approach, and the explicitly stated sustainability perspective. Commissioned by the World Business Council for Sustainable Development (WBCSD), it was prepared by leading experts from MIT and the consulting firm Charles River Associates and lays the fundamental issues of a sustainable approach to freight transport quite clearly.

Chapters 6 and 7 of the report are of specific interest for our work. Chapter 6 is dedicated to freight mobility and after an initial presentation of the meaning and importance of freight mobility continues with a description of the “components” that constitute the freight system (urban, regional, and national freight movements). The report offers a convenient spatial measure to classify the movements with urban being within an area of 100km, regional between 100 and 500 km, and national or continental more than 500km. A presentation of the major types of cargo and modes comes along next with a comment regarding the importance of cheap freight movements as a driver of the global economy.³⁴

Then they proceed with classifying the sustainability concerns for freight transport as following.

(i) **Operational and system sustainability** concerns:

- *Capacity and congestion.* Capacity constraints and the resulting congestion increase transport costs.

³⁴ Transport costs for container cargoes shipped by sea costs can be less than 1% of the actual cost of the product and yet the distance crossed is across continents.

- *Infrastructure availability.* Capacity is linked to the availability of ports, highways and even critical pieces of unique infrastructure like the Panama Canal. While the developed nations face capacity constraints, developing nations may not even have enough options. As they indicate, the railroad infrastructure in India and China bears the brand of their economic expansion but since the railroads do not face enough competition from road this may lead to suboptimal utilization and expansion.
- *Secure trade routes and stable financial markets.* Disruptions in critical infrastructure nodes as well as in the trade transactions can impact the economy.
- *Economic sustainability.* A key concern is to maintain transport costs at a level that does not inhibit national and international trade and at the same time maintain the availability of freight transport options as the economy expands. Freight transport is one of the most competitive industries with very low margins and this kept the final cost of products from rising. Fuel-shortages and congestion may not allow the continuation of that trend.
- *Bad Public Relations.* Difficulties encountered in expanding infrastructure or truck sizes are also part of a bad PR case in which the public is not consciously supportive of the freight transport industry.

As ways to address the operational sustainability concerns the following issues and adjustments are discussed:

- *Productivity improvements.* These improvements can be traced in (i) public and private infrastructure investment, (ii) technological innovation, and (iii) institutional and regulatory changes.
- *Privatization and deregulation of the rail industries.* Although some connect the decline of rail freight traffic in the U.S. with deregulation the experiment has proved comparatively successful. Still the issue remains on how to increase the market segment of rail in the right freight movements (bulk, containerized and specialized).
- *Maintaining freight mobility in congested areas.*
- *Rationalization of the rail industry and coordination with the trucking industry.*
- *Building of infrastructure (both rail and highway – truck-only-lanes or TOL) that will allow higher utilization and economies of scale through heavier loads.*

Following the operational sustainability issues the report raises the main environmental and social concerns related to freight transport:

- *Energy use and CO₂ emissions.* Freight transport uses approximately 43% of the energy expended for all transportation activities within OECD. Two main forces drive the energy use profile in freight; cutting costs and increasing speeds. From a spatial perspective concentration of warehouses reduces the need for many truck trips and allows service with bigger trucks but this trend is countered by the consumer use of automobiles to visit centralized retail facilities.
- *Air Quality Impacts.* Two main polluters are mentioned: older diesel trucks and ships that use bunker fuel due to its very low grade and high concentration of toxic substances.
- *Social and environmental disruption to communities.* The focus in this area is on developing countries and the high impact that infrastructure development has on pristine environments as well as the limited growth opportunities provided from extraction of finite resources.
- *Environmental concerns of ocean shipping and domestic waterborne freight.* Dredging, emissions, and oil-spills are the major issues here.
- *Safety.* The effects and causes of accidents in rail, truck, and sea-shipping are discussed.

In Chapter 7, they enumerate the challenges to sustainability by mode but also identify the “grand challenges to sustainable mobility.” Those pertinent to freight transport are:

1. Ensuring that the transport system continues to play its role as economic development role.
2. Reinvent the process of planning and managing the infrastructure.
3. Reducing carbon emissions.
4. Resolve the antagonism between freight and personal transport for access.
5. Anticipate congestion.

The main policy questions raised revolve around balancing the trade-offs that are present in the above challenges. Namely (i) the trade-offs between demand in mobility and environment protection, resource conservation and safety, (ii) building and managing infrastructure, and (iii) harmonize regulations so that the trade-offs in (i) are consistent with the policy decisions. Finally, the Mobility 2001 report comments that applying the OECD recommendations for sustainable transport in a way that land use, pricing, and infrastructure policies are mutually supportive and *integrated* has been proven extremely difficult and almost infeasible. Yet, the *integration* of separated functions in (a) infrastructure and operations, (b) various interacting modes, and (c) infrastructure financing and pricing are considered key by the authors of the report.

4.3.1.2 Urban Freight: the Niles MTI Report (50) and Ogden (25)

This report is focused on policies for the facilitation of urban freight movements; it is largely based on the landmark textbook by Ogden written in 1992 that also revolves around urban freight (25). Urban freight movement is of interest for our purpose for three reasons: (i) major production and consumption takes place in urban/metropolitan setting making it a critical part of the supply chain, (ii) the urban freight movement link is one that is most vulnerable to congestion and exacerbates the impact of freight transport’s negative externalities due to the urban/residential setting, (iii) the recommendations, insights, and analytical tools used for urban freight transport planning can be generalized for application in the setting of the whole supply chain.

Both the Niles report and Ogden classify freight movement based on demand-driven and supply-driven factors as well as on origin/destination pairs. They use this as a base for analyzing freight movements and eventually construct what they call a Regional Freight Logistics Profile (RFLP) – a framework for regional freight analysis. In Section 6.1 under the subject of modeling we elaborate on and expand their approach to fit regional rather than urban freight planning.

Their analysis concludes that the following areas are the main arenas where Public Policy and Freight transport interact on an order of diminishing influence:

- Transportation infrastructure investment,
- Traffic Operations Management,
- Vehicle Regulations, and
- Results of business decisions.

Their assessments and proposed RFLP framework have been used and expanded upon in Chapter 7. Yet, this report was aimed mainly to trucking issues and related congestion problems and did not try to include the total set of influences that the public sector exerts on freight traffic.

4.3.1.3 Moving the Economy (MTE) Group

This Canadian group has published various studies on transportation issues of which are of interest for us the “Moving Goods in the New Economy” primer written by Miller et al. (52) and the “Building a New Mobility Industry Cluster in the Toronto Region” a collaborative project between MTE and ICF Consulting (53). Like the Niles report, these studies are also focused on urban freight movements.

The former begins by presenting the new logistics trends emphasizing supply chains, JIT, and globalization. It then proceeds to discuss the impact of freight transport in Canada and the more specifically the position in the freight flows of the Ontario area and Toronto more specifically noting the scarcity of available space for logistics operations and the existence of many studies which were not followed up by actions.

The report discusses the importance of short haul rail lines (less than 500 km) as potential relievers of freight traffic from congested highways with a more benign environmental footprint. Supporting the viability of these projects case studies of regional lines are presented (Algoma Central, Ontario Northland, BC Rail, Expressway short haul land-bridge project, the RoadRailer dual mode trailer). Tax structures and land use planning, in order to accommodate both residential and industrial uses along the lines and foster the development of new sidings while not inhibiting the building and maintenance of the lines, are noted as important.

A presentation of modern developments in the supply chain is accompanied by case studies. *Ryder Logistics Inc.* is showcased as a 3PL provider; their performance metrics for serving *General Motors* factories are shown in Box 4-2. Another logistics provider *Exel Americas* by operating a logistics campus in the Toronto area provides a case of operational advantages mainly due to freight consolidation, labor flexibility and sharing of resources among clients, established relationship networks. These result in reduced freight costs due to volume discounts, improved transit times, product integrity, and increased productivity. Freight consolidation and integration of supply chains (i.e. mixing inbound and outbound flows from various locations) are critical trends that lead to improved efficiency even though orders are becoming smaller and more frequent.

Box 4-2 Performance Metrics Used by a 3PL (Ryder Logistics Inc. for General Motors -- MTE (52))

- Determining optimum locations within plant for inventory.
- Inventory savings,
- Equipment utilization,
- Average unload times,
- Percent of inventory value on a plan,
- Delay times at suppliers or plants,
- Planned vs. actual miles,
- Premium freight,
- Integrating suppliers with the overall plan,
- Trailer reduction,
- Safety activity,
- Carrier performance,
- Amount of total number of special deliveries.

The authors assess freight policies in Canada as practically non-existent and they comment that this allows Canadian cities to adopt *integrated* policies informed by best practices around the

world. As main policy options they mention strategic investment in corridors, ITS, as well as regulatory changes that affect the modal balance. In addition there is preparation from the part of municipal officials to support the operations of logistics centers and plan the requirements for their operation. As one means to support public-private cooperation they refer to the U.S. MPO working councils or the EU technical committees. Finally, as an important backdrop to the above they stress the need for collection of reliable data.

4.3.1.4 European Transport Policy

As discussed in Section 3.3.2, European transportation policy is being largely defined by the relevant research programs. In this section we simply present the various projects that focus on freight transport and the interface of private and public actors that are active in Europe along with a very brief summary of their findings. We base our presentation on the concise report by Schäffeler (54) under auspices of the PORTAL Project (55).

Schaffeler classifies the relevant projects into the categories shown in Table 4-1:

Table 4-1 Classification of EU Research Projects on Freight Transport (Source: Schäffeler (54))

Freight Movements	
LEAN	Development and demonstration of new concepts for freight distribution within cities
BESTUFS	Identification of success criteria for the movement of freight
IDIOMA	Demonstration of the potential of optimization of freight movement in 5 urban areas within Europe
COST 321	Preparation of innovative measures to improve environmental impacts of freight transport in urban areas
SOFTICE	Identification of cost of freight transport within Europe with regard to harmonization in Europe and internalization of external cost
Optimal use of networks	
DIRECT	Analysis of the aspects of transport-data sharing structures for better databases for traffic management within cities
Efficient transshipment	
FV-2000	Discussion of several freight villages in Europe
FREYA	Investigation of access of small and medium-size enterprises (SME) to intermodal transport
IDIOMA	Presentation of city delivery centers in 5 European cities
INFREDAT	Investigation of the whole transport chain of intermodal transport, focusing on the requirements of data flows
REFORM	Analysis of the effects of freight intermodal platforms regarding the urban traffic
Container Standardization	
COST 339	Guiding principles for standardization of common container platforms that are usable during a whole transport chain within Europe and compatible with palletization

Given the variety and extend of the projects an attempt to present their findings extensively is beyond the scope of this document. In the following we simply handpick some of the conclusions. Notably in many of the projects internalization of external costs through pricing is considered as an important step towards more efficient use of the network's resources.

Additionally, the existence of efficient networks and intermodal facilities is considered as enhancing regional competitiveness. Finally, the confidentiality hurdle that private/public (and even private/private inter-company) cooperations face is proposed to be handled through an official authority.

4.3.1.5 U.S. Transport Policy on Public/Private Cooperation on Freight Transport

On the U.S. side, unlike the European situation we described above, there exist specific transport policy guidelines regarding freight policies that are recommended for use by the federal DOT. These can be found on the U.S.DOT FHWA Planning website (56). The guidelines stress the public/private nature of a coherent freight transport policy by recommending the assembly of *freight advisory councils (FAC)* comprising shippers, manufacturers, transportation providers, state representatives and infrastructure operators. According to the FHWA website, already existing committees include the following:

Puget Sound Regional Council (PSRC) – Formed in the Seattle-Tacoma region in 1994 PSRC’s FAC facilitated freight data collection efforts and assisted in creating a list of short-term improvement projects, and freight-related MPO planning education.

Metropolitan Transportation Commission (MTC) – As the MPO of the region that includes San Francisco, Oakland, and San Jose MTC formed a FAC to address private freight sector concerns and to provide them with a voice in the planning process. Similarly to PSRC proposals of short-term critical infrastructure projects, truck-surveying, and education have been among the primary actions of the council.

Capital District Transportation Committee (CDTC) – Operates in the Albany-Schenectady-Troy metropolitan area in upstate New York.

Chicago Area Transportation Study (CATS) – With Chicago being the nation's largest intermodal freight area, goods movements consideration have a history that dates back to 1970. CATS FAC conducts surveys, identifies bottlenecks, composes the intermodal element of the Transportation Improvement Plan (see Section 3.3.1), and completes an inventory of the region's intermodal facilities.

Comparatively
Weak
Centralized
Control

Based on the experience from the existing FACs the FHWA Planning guidelines indicate a set of freight-related planning activities. Those activities can span from data gathering to project financing. More specifically they can include:

Lists of Improvements: The experience of FAC members can offer valuable information on bottlenecks and other inefficiencies in the freight. These can be listed and prioritized. One way to organize the project list is the “Action Matrix” approach – first used by the PSRC – that classifies actions into four groups:

Institutional: affecting the relationships among actors;

Operational: affecting the operations of the regional freight transport system;

Infrastructure: affecting the physical network and facilities; and

Financial: affecting the ways the actions above are funded.

Potential FAC
Activities

Corridor Studies: Going further than the identification of individual issues the FACs have been used to consult larger corridor-wide studies.

Ad Hoc Working Groups: These are simply looser alternatives to FACs that have a more localized or mode-specific scope.

Modeling/Data Collection: Finally, the experience of FACs can be tapped to provide decision-support models for the region. Additionally, the interaction of public and private sector can

increase the trust of private-sector executives towards their public-sector counterparts and hence be more willing to share sensitive data as well as control the type and use of the data provided.

The MPOs that decide to proceed in the creation of FACs need to prepare accordingly by educating their staff and creating a process for incorporating the goals and perspectives of the private sector with those of the MPO. The FHWA guidelines recommend that this preparation be made in steps: setting the MPOs own goals,³⁵ considering how the FAC will fit into the existing structure of the MPO and what duties would it have, alignment of the perspectives of the two sectors, understanding where the motivation of the participants, and identifying the private sector members that would be a good fit and provide valuable input.

Finally, the FHWA guidelines discuss how to energize and retain the private sector interest. The focus is on creating the sense to private-sector participants that their resources (time and funding) are productively spent. Short-term yield projects, productive meetings, and aligned goals can work towards sustaining the participants' enthusiasm.

4.4 Overview

In this chapter we reviewed the state-of-the art of freight transportation planning as employed by governments in both North America and Europe as well as transportation planning research conducted by academic institutions or consultants. As a general conclusion, we can deduce that consideration of the impacts of the supply chain are only nascent, if they exist at all, and the reason for this is probably supply chains are complex and the bulk of its effects on transport flows are indirect and hard to quantify. European and the Canadian transportation policy statements follow a much broader yet less structured approach to transportation planning compared to the those implemented in the U.S.

Our aim in Part 2 is to push forward the more systemic view of transportation planning in freight. For this reason in Chapter 5 we enumerate and briefly review the shortcomings of transportation planning processes that we saw and outline how the use of CLIOS in transportation planning can address some of those shortcomings.

³⁵ As far as the goals are concerned the FHWA planning framework notes that they should be mainly focused on the efficient movement of goods with no reference to the sustainability concerns discussed in this thesis.

Part 2

System Analysis

The best way to predict the future is to create it.
- Peter Drucker

5 Regional Strategic Transportation Planning as a CLIOS³⁶

Having discussed the state of the art in transportation planning in Part 1 we introduce in the first chapter of Part 2 a comprehensive alternative framework for transportation planning. Structured as a holistic process, our framework stresses the importance of operational and infrastructure considerations while encouraging the participation of a full range of stakeholders. In Chapter 5 we sketch the framework for regional transportation planning in general and in Chapter 6 we flesh it out focused on sustainable freight transportation so that it integrates SCM and RSTP in one unified approach.

5.1 Transportation Planning: A Review

As a precursor to discussing how the CLIOS process can be adapted to the special case of regional strategic transportation planning (RSTP) we first review the state-of-the-art in transportation planning in the U.S. Regional transportation planning is a process involving numerous agencies at several levels and performing different missions. These agencies create plans that will affect the physical and institutional layers of regional transportation. The timeframes, interactions and details of the plan vary from region to region but since strategic planning is long term by definition, this section primarily focuses on the long-range transportation plan (LRTP) but describes other plans as well.

5.2 Shortcomings in Contemporary Transportation Planning

In 2000, Conklin and Sussman (2) summarized the common shortcomings of traditional transportation plans that they identified in their review of transportation strategic plans in the Netherlands, the States of Washington, Iowa, New Mexico, Florida and others. The areas where shortcomings were identified included:

- *Intermodalism.* The unimodal perspective usually adopted in planning as opposed to the often more fruitful intermodal approach. Planning seems to lack an integrative flavor and leans towards multimodalism where several modes coexist but low effort is made at easing the transitions between them.
- *Economic integration.* The lack of emphasis on economic integration and creation of regional competitive advantage. Transportation plans have only recently started to seriously consider business firms, freight issues and private sector involvement.
- *Freight.* The overemphasis on travelers and the underemphasis on freight in the planning process. This picture has started to change in areas where freight transport is critical.
- *Private sector involvement.* The lack of private sector involvement in the planning process and in financing of transportation infrastructure.
- *Operations.* An overemphasis on a master plan defining conventional infrastructure and an underemphasis on integrating operations planning into the overall process.
- *Technology scanning.* The absence of long-term technology scanning—looking out several decades for technological developments that could impact the regional transportation system and its customers.
- *Transport and telecommunications.* Shortcomings in considering the synergistic relationships between telecommunications and transportation systems.

³⁶ This chapter is based on Sussman, Sgouridis, and Ward (29) submitted for publication as a stand-alone paper at the TRB conference.

- *Human resources.* A lack of direct concern with the development of human resources in the professional transportation community—of particular concern in this era of an aging workforce and the need for transportation professionals to understand new technologies and methods.

To the above shortcomings identified in 2000 we add the following:

- *Sustainability.* Limited focus on long term multi-dimensional sustainability.
- *Institutional change.* Lack of concern with the need for institutional change in the planning and operations process, engendered by the regional scale of operations and changing pressures on the transportation system.
- *Uncertainty management.* The lack of emphasis on dealing with uncertainty and utilizing appropriate tools to forecast future demand and to value the flexibility of designs.

The shortcomings listed above were evaluated in today's context taking into account the current trends in planning as described in the previous section and compared to contemporary plans from the U.S. MPO's. Although there has been progress on the various areas that were identified, this progress is uneven. The fact that transportation plans are not comprehensive is an anticipated side-effect of them being developed through an inherently political processes based on limited resources but in this work we strive to include all major aspects that should be addressed for completeness. The CLIOS process described below is, we believe, a significant tool that enhances completeness.

A Recent U.S. DOT Planning Framework

Recently, in 2004, the planning unit of the U.S. DOT published some general guidelines for informing the procedures followed by the individual Metropolitan Planning Organizations (MPOs) in the U.S. which addressed some but not all of the issues outlined above. Their schematic framework is presented in Figure 5-1.

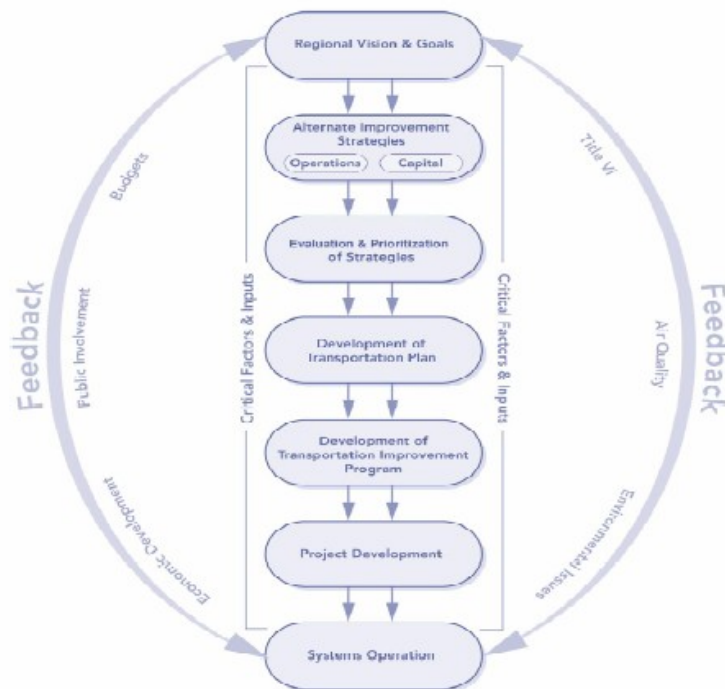

Figure 5-1 MPO/DOT planning framework [Source: (34)]

The MPO/DOT diagram introduces a sustainability perspective in the feedback loops on the two side-arrows of the process. The issues of economic development, environmental impacts and environmental equity (Title VI) are prominently featured along with the financing considerations. At the two poles of the planning loop are the development of visions and goal and system operations. The intermediate steps involve the design of general strategies or strategic options and laying out the actual transportation plans. Overall, the MPO/DOT framework addresses many of the issues identified in the previous section but it does not refer to changes of organizational structure or institutional responsibilities and, as far as practice goes, it is still far from being the accepted state-of-the-art planning framework.

We propose that the use of CLIOS, a general framework for analyzing complex systems, would provide benefits to the RSTP not explicitly captured by the framework presented above. The next sections briefly describe CLIOS and conduct a thought experiment of how CLIOS can be used in RSTP providing an initial take on the procedure. It should be made clear that we are not trying to replace the existing approaches but rather inform them with insights from the CLIOS process. Having now set the stage, we briefly introduce the CLIOS process and discuss how it can be used in the RSTP domain.

5.3 RSTP as CLIOS

Characteristics of the CLIOS Process

- “Christmas Tree”: The tree is the process; the ornaments are the tools particular to the CLIOS of interest.
- Diagrammatic approach to understanding the CLIOS at the representation phase.
- Nested complexity: bi-directional relationship between the physical and the institutional.
- Institutional change as a strategic option.
- Step-by-step, yet iterative process: an organized structure for analysis, design and implementation.

The CLIOS (Complex, Large-Scale, Integrated, Open Systems) process is discussed briefly in Section 1.3 and also in the extensive paper by Dodder, Sussman and McConnell in (8). In this section we follow the CLIOS process step-by-step applying it to RSTP for a generic region.

5.3.1 Representation Phase of CLIOS Process (Steps 1-5)

To begin the application of the CLIOS process to Regional Strategic Transportation Planning (RSTP), we represent in Figure 5-3 the region under study physically and institutionally in the nested complexity (physical complexity surrounded by institutional complexity) CLIOS diagram, seeking insight about the system. Similar to the DOT/MPO framework, the CLIOS representation phase (Figure 1-2 and for a full scale view Figure 5-2 show the steps in the CLIOS process) starts by bounding the issue to be examined: identify the problem, the vision that will drive the solutions and the more specific objectives.

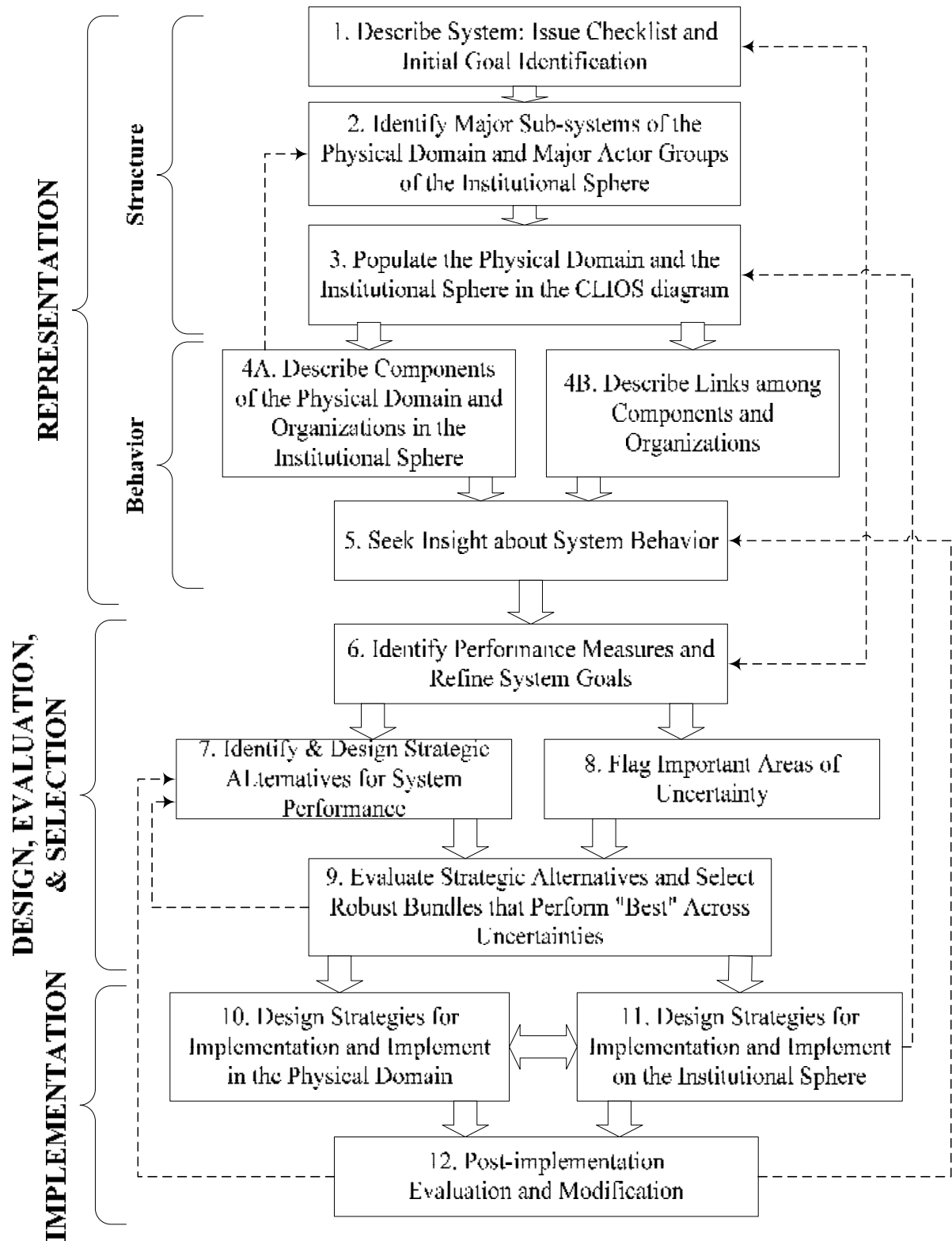

Figure 5-2 The CLIOS Process

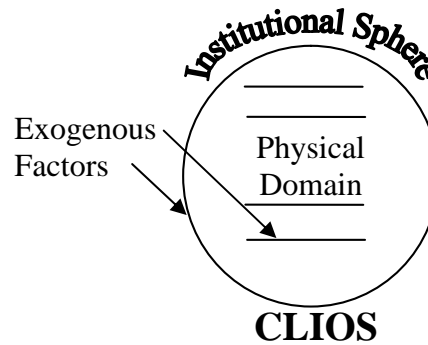

Figure 5-3 Nested Complexity in the CLIOS System representation

Step 1: Describe System: Issue and Goal Identification

In Step 1 a checklist of important issues is created that will act as a guide to ensure that no important factors are left out during the later and more detailed development of the CLIOS. In parallel, a set of initial goals of the RSTP is identified that range within the two following overarching goals: (i) ensuring/providing an adequate, efficiently operated, robust and secure transportation network and (ii) maximizing total societal benefits within a sustainable framework. Of course different regions may choose different goal mix depending on their constituency, perception of competitive advantage, and strategy.

Bounding the problem is critical for the evolution of RSTP – constraining the problem too much would result in a system that may be easy to optimize but that would lack the comprehensiveness needed to create long-term improvements. On the other hand, expanding the boundaries too much can result in an unsolvable problem. At the current level of system thinking it may be possible to optimize on levels that were previously infeasible but political inertia would still halt changes. For the purpose of the discussion that follows, we assume that the implementation of the process is a result of an already resolved political mandate in which the decision-makers favor holistic over incremental set of propositions.

The definition of an overarching goal for transportation planning can be deceptively straight forward: a plausible goal that focuses on the supply side could be the provision of a reliable and cost-effective transportation system that will have adequate capacity to serve the transportation needs of a region for the planning timeframe. Regarding transportation policy goals, as discussed extensively in Section 3.2.1, Ogden (25) describes the same vision but highlighting the importance of reduction of external costs or “disbenefits.” Raising the level of complexity, Hall and Sussman (26) have argued that sustainability must be included in the agenda of transportation planning. They indicate that the pursuit of a sustainable transportation system is not sufficient; the transportation system’s connections with the other sectors have also to be investigated for sustainability.

The policy goals of transportation planning can vary substantially from region to region. Putting the pieces together, general transportation planning decisions would heavily depend on:

- (i) the level of development of the transportation network of the region;
- (ii) the overall policy perception; if for example sustainable development is on the political agenda or not or if there is an interest in public transit and passenger facilities which can appeal to voters better than for example, sophisticated port equipment perhaps because the latter is not directly visible; and

- (iii) the economic condition of the country; i.e. if there is available funding for investment from internal (economic surplus) or external sources (international borrowing or aid). In the latter case the goals of the planners will be influenced by the lenders' or investors' objectives.

Step 2: Identify the Major Subsystems of the Physical Domain and Major Actor Groups of the Institutional Sphere

Step 2 in the CLIOS process emphasizes the understanding of the system as a dynamic entity that consists of physical subsystems nested within the institutional sphere. In the case of RSTP as CLIOS the physical domain may be divided into four major interconnected subsystems (also shown in Figure 5-4): (i) Economy, (ii) Land Use, (iii) Environment and (iv) Transportation. The institutional sphere would include the relevant organization from the public and private side. In some regions additional subsystems may be needed.

This allows for a multi-dimensional consideration of the CLIOS and avoids one of the problems faced by previous regional transportation plans: their lack of full consideration of the various stakeholders and the respective effects of the plan on them on an aggregate level as discussed by Meyer and Miller (35). The decision about major physical subsystems is clearly related to Step 1; while a purely transportation-oriented plan may break-up the system simply in the different modes and nodes in the region³⁷ the more expanded the boundaries the more varied the subsystems will be. As shown in Dodder, et al. (8) CLIOS is well suited for describing the structure of complex systems offering scalability to detail and inter-relations based on the organizational tools of nesting, layering and expanding and using common drivers to weave the subsystems together as described in the next section.

Step 3: Populate the Physical Domain and the Institutional Sphere on the CLIOS Diagram

This step involves the creation of mental and simulation models for representing the system. The subsystems from Step 2 are populated with components. These will represent among other things the transportation network (hardware infrastructure planning involves the "lines on the map"), the demand for transport, and the equipment or transportation fleets along with important relevant characteristics of those components like capacity, energy consumption, and pollutant emissions.

The institutional sphere is populated with public and private organizations. On the public side organizations that regulate, plan, construct, fund and operate transportation projects would be included, like Metropolitan Planning Organizations (MPOs), Federal and State Departments of Transportation (DOTs). Other aspects of the government that can significantly influence decisions on transportation investments, vehicle regulations, and the flows of goods, like the DOE (Department of Energy), and EPA (Environmental Protection Agency) should also be included. On the private side included organizations would be those providing transportation services like trucking, railroad, and shipping companies, non-governmental organizations (NGOs), as well as industry and stakeholder groups that may act as intermediaries between the public and private side.

The different subsystems and their inter-relations can be visualized using the CLIOS diagrams. The CLIOS diagram, a mental model, is based on nesting, layering, and expanding. Nesting allows for the incorporation of physical systems within the organizations that operate them. Layering allows for different levels of detail, so, for example, the transportation subsystem can be layered into the transit sub-layer, along with the highway sub-layer and the airport sub-layer. The

³⁷ We distinguish the hard transport network planning as drawing "lines on the map" since it can be represented as such as opposed to operations design which is concerned with methods and practices.

layers are populated by components that can represent physical or regulatory aspects of the system. In our example, the transit system sub-layer will include components representing the underground metro, the bus lines, and commuter rail, along with components like passenger demand, fare price, and public financing. Components like financing, or safety regulations are called policy levers and are distinct from the physical components. Moreover, the components that affect more than one layer, e.g. demand for travel or intermodal stations are called common drivers. If finer detail is required for a specific component then expanding allows for a close-up view of the structure of a specific component.

The ultimate goal of the representation stage is to create a representation and experimentation platform where the existing infrastructure, organizational structure, and impacts on economy, land use and the environment are represented. Figure 5-4 shows Step 3 and demonstrates how a CLIOS diagram representation is articulated using nesting, layering, and expanding based on a generic large scale transportation system. The process is illustrated from left to right but due to space limitations, it is illustrative and therefore far from being complete. On the far left the actual system is represented as CLIOS with the physical domain and institutional sphere. Next, the physical subsystems (economy, land use, environment and transportation) are distinguished and the institutional sphere is mapped on a plane. As an example the transportation layer is shown on the right and several components are shown: common drivers like GDP, location of activity and emissions; policy levers like emission limits and congestion charging regulations; and elements specific to the layer like the highway infrastructure are added. Finally on the far right, we show the expansion of “highway infrastructure” element to provide additional detail.

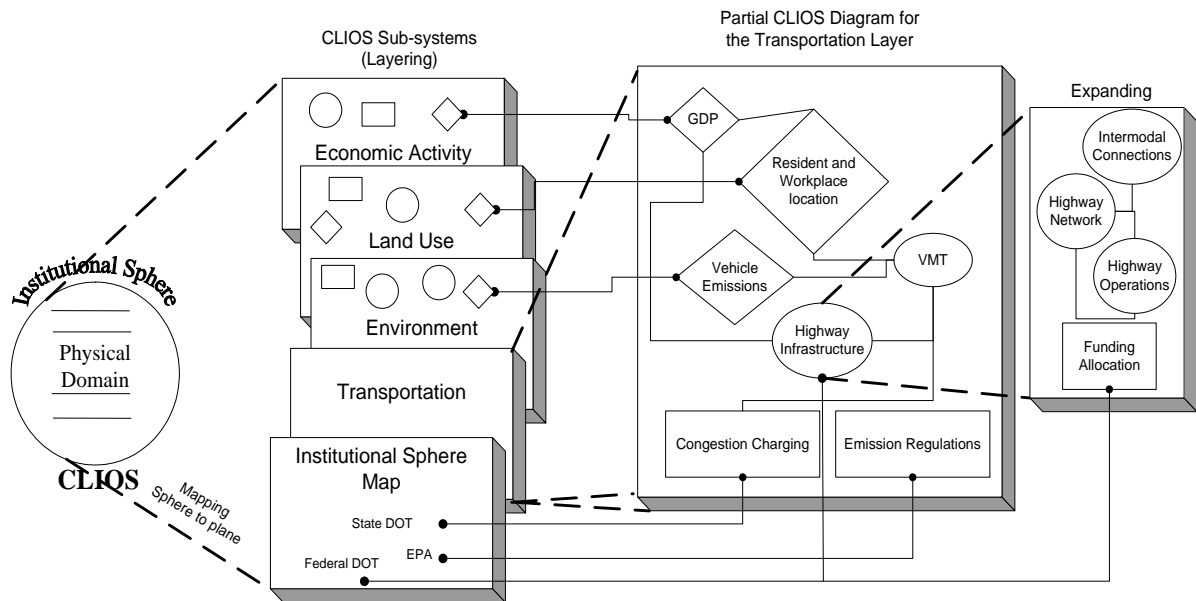

Figure 5-4 View of the Step 3 of the RSTP CLIOS Representation Process

Step 4: A. Describe Components of the Physical Domain and Organizations of the Institutional Sphere. B. Describe links among Components and Organizations.

This step is directly connected with the development of the CLIOS diagrams. The description of components and links ensures the understanding and continuity of the CLIOS process. The effects of the institutional sphere on the physical domain are visualized as projection of their policies on the various subsystems as policy levers. The interaction of links among physical components as

well as between the institutional sphere and the physical domain can be quantified using micro-economic or simulation models whereas the links between organizations within the institutional sphere can only be approached qualitatively.

Step 5: Seek Insight about System Behavior

Having created a working model of the CLIOS the system's behavior can be studied in Step 5. To proceed from a static to a dynamic system representation (simulation) that would allow experimentation various methods can be used. One promising way to do this is being developed by Mostashari and Sussman (36): their Stakeholder Assisted Modeling and Policy Design (SAM-PD) uses system dynamics as a base model where the interactions among the subsystems can be visualized in a dynamic fashion. The proposition is that stakeholders are called early on to provide their intuition and expertise on whether the representation is accurate. The introduction of the stakeholders at this early stage of the process is important not only for the system knowledge they can offer but it can be politically helpful. If handled correctly, this creates a positive climate and makes it useful as a change management tool – the stakeholders' potential resistance to novel recommendations can be overcome when they feel part of the plan formation process.

5.3.2 Design, Evaluation and Selection Stage of CLIOS Process (Steps 6-9)

In the evaluation/design stage a variety of strategic options are developed. One output of this process is what we call the “regional infrastructure” – or as we characterized it in footnote 37 the “lines on maps.” Based on the description of the system and the goals of the process, we define RSTP more broadly to include fleet, technology, and environmental considerations, land use policy, operation actions such as congestion pricing and so forth. These areas where transportation planning has an impact and different choices can be made are shown as strategic options in Figure 5-5.

The notion of Architectures was introduced in the Introduction (Section 1.3). Figure 5-5 brings in the idea of institutional “architectures” that denote the institutions and their relationships that plan the transportation system (regional planning architecture) and the ones that operate it (regional operating architecture). Of particular interest is the recursive nature of the planning process in that it is charged with “reinventing” the regional planning architecture for the next cycle of the planning process. Also noteworthy is the output of the planning process we call an “operations plan” -- think of it as “planning for operations” (as opposed to planning for capital facilities -- the “lines on maps”) and a regional operating architecture (usually different than the regional planning architecture) responsible for the operations process. Integration is the watchword. So, central to our thinking is the integrated treatment of the planning process and operations process. A discussion of how the steps in the evaluation stage (steps 6-9) of the CLIOS process relate to this particular application to RSTP follows.

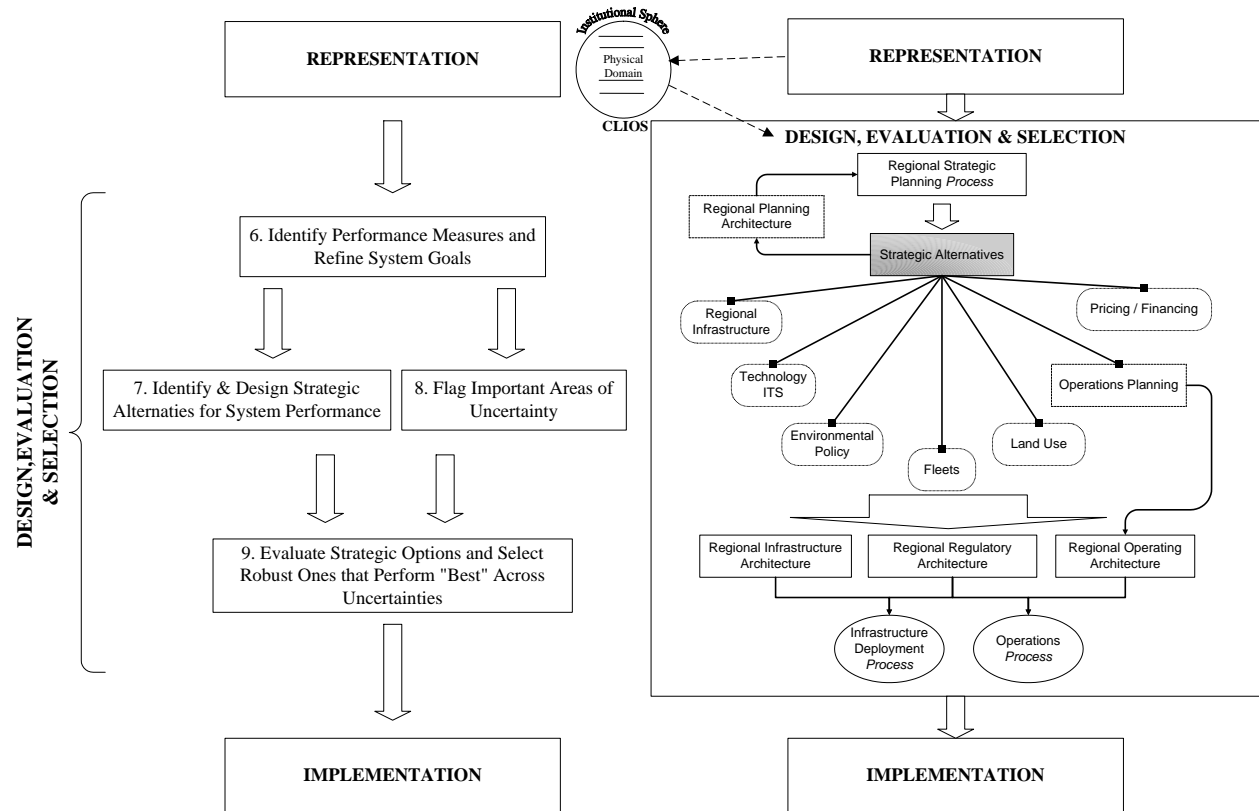

Figure 5-5 Strategic Options in the Evaluation Stage of CLIOS

Step 6: Identify Performance Measures and Refine System Goals

In Step 1 of the representation phase there was a discussion of the broad goals of the transportation system. In this step the goals are refined and another aspect is considered: economic competitiveness of the region. We argue that a regional strategic transportation plan is important not only for offering an adequate and efficient transportation system but for creating a competitive regional advantage. The sources of competitive advantage for a region, according to Michael Porter (37), should be sought beyond providing good infrastructure and a sensible tax policy. Hence, strategic transportation plans should provide: (i) a good infrastructure, if it is lacking but, most importantly, (ii) competitive advantages to the firms operating within the region. Further discussion on how transportation systems can be viewed as competitive advantages and facilitate clustering can be found in Grube's MIT Master's thesis (38).

Competitive advantages can be measured in productivity increases but go beyond simply providing transportation. Competitive advantages can be derived from pursuing the following strategic policies:

- institutional integration or rationalization through a regional planning architecture (provides an advantage as it creates a stable, clear-cut organizational environment that is more effective and allows clear-cut working relationships with the private sector)
- operations planning and a regional operations architecture (incident management and future flow forecasts create a more reliable system)
- modal integration on the infrastructure level (enhances modal choice and system resilience)

- informational integration using ITS and provision of ITS infrastructure (the versatility of use for this information is limited only by the innovation capacity of the firms)
- facilitation of freight traffic to ensure reliable access to markets and manufacturing inputs
- coordination of land-use policy and transportation access (clustering supported by infrastructure - freight villages, preventing conflicts of housing and industry)
- coordination of environmental policies that result in enhanced quality of life for skilled labor and headquarter positioning.

In order to gauge the success of strategic policy options, different measures can be applied for each one of them. Individual measures are easier to conceive and track but they may create a false impression of overall system performance. Hence performance measures for the system as a whole are needed too. Some critical issues at stake in a regional transportation plan are (i) regional competitiveness and economic development, (ii) environmental quality and sustainable resource use, and (iii) equitable distribution of benefits (progressive measures) and convergence with land-use policies. Strategic plans that positively target all three areas may be hard to visualize but, in any case, the implications of the plan on all three should be explicit and measurable in the models used to represent the system. This means that there is a need to create measures that are calibrated to compare economic, social and environmental outcomes. The creation of adequate measures of these qualities is still nascent. It is an area where there is potential for significant contributions. Conventional performance measures have been related to the various aspects of the projects and plans. There are mobility measures (e.g. percentage of people that commute to their work in an hour), capacity and operations measures (i.e. percentage of time an artery is congested or utilization of a facility), project management measures (e.g. projects constructed on time and budget), safety measures (e.g. accidents per vehicle-mile) environmental measures (emissions per vehicle-mile or per ton-mile) and others. These measures can translate to monetized benefits as reductions in travel time, vehicle operating costs, environmental impacts, and accident avoidance have direct and indirect monetary impact which can affect the cost of doing business in the region and eventually personal income. Since these numbers can be highly speculative and influenced politically, managing to tie the economic with the social and environmental under a standardized carefully calibrated procedure that is non-controversial to the stakeholders would be a major breakthrough. At the current point, different measures like the ones above are used to cover different areas and multi-criteria analysis is generally used to make the final valuation. This creates two concerns: (i) it makes the procedure value-laden and crucially dependent on stakeholder judgment and (ii) it does not guarantee that the metrics used to evaluate the performance of subsystems accurately describe the aggregate system performance.

Step 7: Identify and Design Strategic Alternatives for System Performance

Having identified the strategic goals and created a process to measure the successful achievement of those, the CLIOS process continues to the critical step of envisioning and designing the strategic options that should accomplish the stated goals. The strategic policies from the previous step are intended to satisfy the region's goals and provide it with a competitive advantage. In this step, for each policy projects and actions will be studied in the form of strategic options. Often, projects can contribute towards more than one goal. For example, an incident management system may provide operations improvement but in addition it may provide data to an information system and clarify the institutional role of the entity that uses it.

The options may differentiate not only on the type of project but also on variations on the same theme. The same project can be financed with a variety of ways or be priced to the user with different formulas. These variations on a theme do not provide a direct advantage per se, but set

the stage for the advantages to be realized by enhancing project viability. These “variation” options include:

- Innovative financing (for creation of additional infrastructure – Miller (47) compiles an exhaustive list of financing methods)
- Balanced infrastructure pricing (could be congestion pricing or other forms of pricing to promote fair use of the provided facilities and allow for capacity)
- Fleet technology and age requirements (conforms with environmental policies and allows for increased productivity of both freight and transit vehicles).
- Regulatory changes.
- Institutional architecture (planning and operation) modifications (reduces overlap and institutional inertia when it comes to planning, enforcing, and monitoring changes).

For example, if the establishment of public transportation line in a corridor was identified as providing a competitive advantage, then possibilities like Light Rail Transit, Bus Rapid Transit, underground metro or informal colectivos (as in Mexico City) could be examined as different project options. These options can in turn vary on project financing; the possibilities of Built-Operate-Transfer, of Built-Own-Operate, of public financing or bonding should be evaluated for each project separately if this can alter the viability and attractiveness of the project. Although the enumeration of variations cannot be exhaustive, missing a potential alternative reduces the decision-space and in some cases will result in diminished performance.

Step 8: Flag Important Areas of Uncertainty

This step is important and interrelated with Step 9. Strategic decisions are made in the presence of uncertainty since for the most part they rely on forecasts of future demand. In RSTP forecasts of demand, of economic and environmental impacts, or of land-use patterns are used among others. As de Neufville (48) asserts, “the forecast is always wrong,” meaning that even in relatively simple cases the quantitative extrapolation of data from past trends gives a false sense of accuracy. Quantitative models should be used as indicative since however well-validated a model may be, there will still be instances where its predictions will be wrong or inconsistent. Understanding the models in-depth and informing the decision-makers and stakeholders of their limitations is critical for the success of RSTP. In addition, the use of techniques for risk-assessment, risk-management, and flexibility valuation can be fruitful for the success of the plan along with periodic re-evaluations.

Step 9: Evaluate Strategic Alternatives and Select Robust Bundles that Perform “Best” Across Uncertainties

This is the integrative step, where all the above steps fit into place. The policy goals generated in Step 6 and the strategic options to reach them of Step 7 are not easily evaluated or compared on a quantitative basis. As policy decisions they need to be discussed on a qualitative level and with a broad spectrum of stakeholders. There is a combination of system modeling tools that is able to assist the process even on that high level. The suggested process combines scenario planning and the SAM-PD system dynamic model mentioned earlier. Scenario planning requires the imaginative projection of a number of possible futures that impact the performance of the system configuration. The system dynamic model is an overarching model that represents all the interactions in the system. This overarching model interconnects a number of lower level models that represent the various subsystems. Finally, the performance of the overarching model is tied with a macro-economic forecasting component. This technique allows independent models of different options to be tied together in a system model. Eventually this can simulate how the system will react to different options implemented simultaneously as bundles. This way, using the performance measures developed in Step 6 the overarching model can provide a ranking of

projects under each strategic option; the projects that perform are robust across scenarios are ranked higher.

Creating an integrated model to represent the whole system and test the various scenarios can be hard because of the complexities, development costs and uncertainties that are involved. In this case a more conventional approach of policy deliberations can be informed by project specific rather than system-wide evaluations. This type of quantitative analysis is more common and can be based on tools like Real Options, BCA - life-cycle costing, simulation modeling (Monte Carlo), system dynamics, genetic algorithms, and others. The projects that are chosen should be expected to perform robustly in a cost-efficient manner for a variety of potential futures, as described above.

5.3.3 Implementation Stage of CLIOS Process (Steps 10-12)

The implementation stage of the planning process involves three final steps.

Step 10: Design Strategies for Implementation and Implement in the Physical Domain

This step guides how the implementation will unfold. It includes actions that are needed to initiate the actual implementation process like the finalization of financing strategies, time prioritization and scheduling of project construction, deciding on pricing of services, reaching stakeholder consensus and authorizations when they are required, etc.

Step 11 Design Strategies for Implementation and Implement on the Institutional Sphere

There can be three main outputs of a regional transportation plan; regional infrastructure network, regional operating architecture, and regional planning architecture. This step emphasizes the importance of as well as the difficulties that can be encountered in implementing institutional changes to conform to the latter outputs. While the options for changes in the institutions that operate the system and those that plan for it have been identified in Step 7 and evaluated in Step 9, it is critical from the CLIOS perspective to review and pursue such changes. Furthermore, any modifications or insights on the interactions of the institutions in the region may also initiate changes in the diagrams as part of iterations in the RSTP process.

Step 12: Post-implementation Evaluation and Modification

This evaluation step relates the performance of the system compared to the goals set in Step 6. The performance measures that were identified then are used for both quantitative and qualitative assessment. But the most important characteristic of this step is that it can serve as a threshold for a more refined and focused iteration of the CLIOS process.

5.3.4 Overview of the proposed RSTP as CLIOS Approach

Our proposed method for strategic planning is deliberately distanced from being project-oriented. Instead the center of attention is placed on more integrated actions like:

- articulating long-term regional goals,
- bringing in stakeholder participation early-on in the process,
- understanding the interactions of the region using dynamic models,
- affecting planning and operations architecture changes to avoid institutional overlap, inertia, and conflict,
- developing bundles of robust strategic options both physical and institutional in nature,
- valuing flexibility and alternatives to big-project construction,
- de-emphasizing single-point forecasts by using ideas such as scenario planning,

- integrating projects in a systems/intermodal perspective, and
- emphasizing the three-dimensional sustainability (economic, environmental, societal) of the system.

The structured CLIOS process when applied on RSTP creates a holistic, systemic approach to transportation planning that emphasizes integration, institutional coordination, and long term sustainability. This makes it capable of addressing the transportation planning shortcomings that were identified in the first section by allowing for expansion of the strategic goals and the strategic options to achieve them. These advantages notwithstanding, the proposed RSTP process suggests needs for more centralized planning and implementation and thus it may encounter obstacles for its adoption. The next section briefly addresses this question.

RSTP Implementation Prospects

RSTP can hardly be expected to immediately displace existing planning processes. A planning agency may be uncomfortable with changing its process because of institutional experience with the old one, or lack of skills for some parts of RSTP that go beyond traditional transportation boundaries. Perhaps the agency is currently engaged with its process and does not want to be disrupted. RSTP can be phased-in to the agency, to allow its comfort with RSTP to grow. While some parts cannot be added wholesale in the middle of the process without great disruption, parts of it can. The main variable to consider is how connected it is with other parts of the process. Adding methods for dealing with uncertainty is relatively undisruptive as they can be used in dealing with individual projects to try them out in addition to the normal methods used. The SAM-PD process would be harder to initiate in a similar manner. The connections between operations planning and infrastructure are what make it difficult to substantially align it with the RSTP method midstream despite its similarities to the normal output of the transportation planning process. An increased emphasis on operations could begin but it would be unwise to try a significant overhaul until the regional planning architecture is developed as described previously.

By far the most difficult part will to include institutional change in the regional planning and operating architecture. There are several reasons why it will be difficult to implement this. First, the public rarely clamors for it; unsurprisingly they are interested in transportation projects in a transportation plan. Second, there are many legal and financial structures surrounding the regional transportation system. Many of the meaningful changes in these structures would require many years of work. Finally, institutional inertia will reduce the initiative for change. Many people are comfortable in their jobs, do not want to lose authority, or just do not want to change.

Two possibilities to introduce institutional change on a large scale are either with institutional change being imposed from the state or federal level or the leadership of a politically adept visionary. Federal level change is possible, like the resurgence of MPOs with ISTEA, but it is difficult to forge sweeping changes at the federal level without local government support or a public outcry. The transportation planning process rarely gets the electorate riled up so the reason for change would have to come from local governments and if there is much local support, the federal level changes would be unnecessary except for funding or legal codification purposes. Change at the state level is more realistic as local governments or agencies will have more influence rather than be diluted by numerous other regions with their institutional peculiarities. While a visionary leader would be helpful, it is not something that can be counted on. Absent either of these, regions will have to stick to a long process of small steps towards institutional change. This will require relationship building and taking advantage of opportunities for small changes where they can be found. In the meantime though, every region can consider the list of

generic shortcomings described earlier in this paper with an eye towards self-diagnosis and incremental change.

In the next chapter, we expand on the framework described above and present how it can be applied with a focus on integrating SCM and RSTP towards achieving sustainability goals.

6 Creating an SCM-informed Transportation Planning Process: Decomposition of Freight Transport Planning based on CLIOS

Chapter 6 continues creating a process for transportation planning that explicitly integrates SCM considerations. We envision this as a process that is conducted by the public sector based on direct input from the private sector. There can be interaction between the two stakeholder groups during the planning process as well as through various iterations of the whole process.

Of course, as Table 1-1 showed, the two sectors have different planning horizons and their primary goals may be diverging as well (see Section 6.2.1.1). This implies that the public sector representing the public welfare should be the stakeholder with the greatest authority on the outcome of the transportation plan when it is not possible to reach consensus decisions.

In order to complete a general process we base our work on a generic region (Region A) that we introduce in Section 6.2. This way we also achieve relative simplification of the problem that comes from not dealing with context-specific characteristics that drive the complexity of a real-world region. There are at least two approaches to understanding/designing an architecture; one is the *de novo* case, where a system is studied in a “pure” state, and the other is the legacy design where the system is built upon the cumulative experience of existing designs (Crawley et al. (5)). Since the freight transportation system is an already existing and highly evolved system the intuitive approach would be to rely on the second, or legacy approach. We argue that because of the extreme complexity of the system, the *de novo* approach starting from simple abstract conditions like those used in economics or trade theory (for example Krugman (49)) may provide benefits in understanding the complexity and decomposing the system into its essential elements. In addition, this kind of approach may provide the necessary abstraction level to identify and distinguish between indispensable and “gratuitous” complexity.

6.1 Classification of Regional Freight Flows

As a step to understanding and modeling freight flows in a region, it is useful to categorize freight flows based on generic origin destination pairs. Based on the Niles MTI report (50), in this section we classify the most common freight movements.

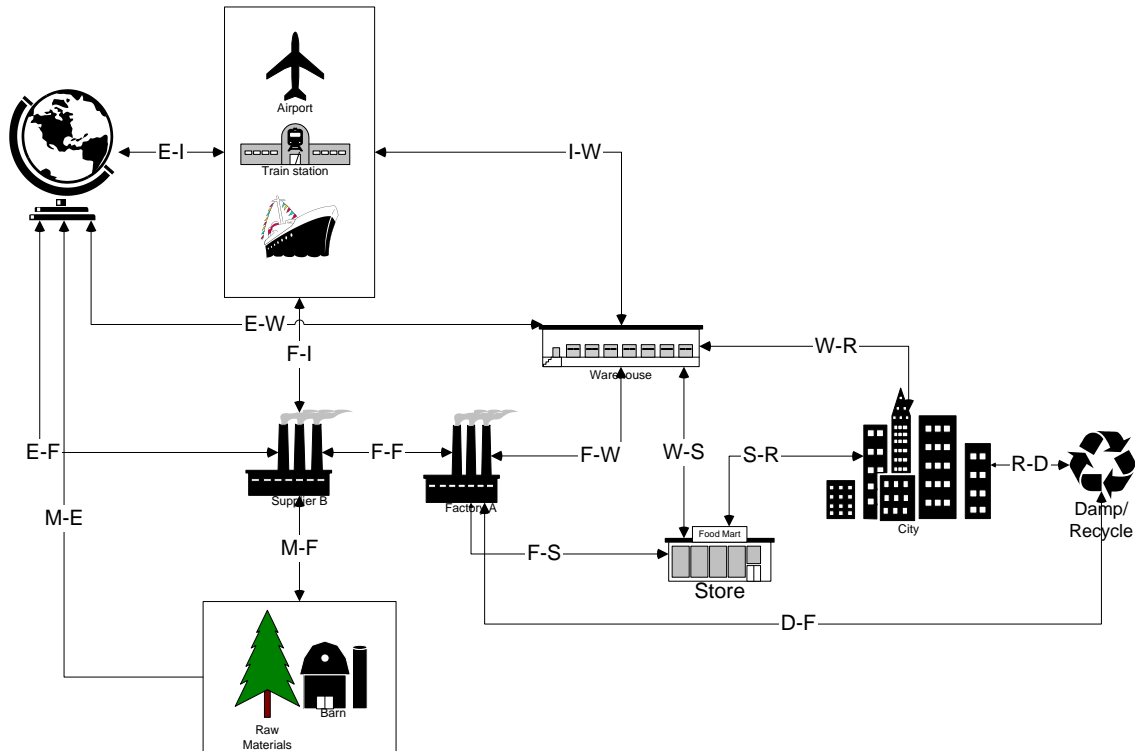

Figure 6-1 Classification of Common Freight Flows

Figure 6-1 and Box 6-1 enumerate the most common freight flows based on the origin-destination (O-D) pairs.³⁸ The notation used for each O-D is the following: **Factories (F)**: Manufacturing facilities in which significant volumes of input in the form of raw materials, parts, and subassemblies are transformed into final products or subassemblies for further processing. **Warehouses (W)**: Warehouses, distribution centers DCs, sorting centers, break bulk facilities, are included. There may be some value-added to the products but this is significantly smaller compared to factories since the output products are the same as the inputs although packaging and load sizes may differ. **Stores (S)**: Retail outlets for products that may also include restaurants, hotels, commercial and government offices, medical and educational facilities. Individual customers or workers purchase or consume goods in their premises. **Residencies (H)**: All types of households. **Intermodal terminals (I)**: Terminals where trucks load and unload cargoes to be shipped using other modes of transport like railcars, airplanes and ships. **External (E)**: This signifies all the regions that are in commercial contact with the studied region and with which exchanges of goods take place. **Raw Material (M)**: Agriculture production, mining, oil-drilling are activities and land-uses that fall under this category. The products from this source need further processing to be used by consumers. **Damp/Recycle (D)**: Finally, this area represents disposal and/or recycling facilities for the products at their end-of-life.

³⁸ Movements inside the region are expected to be conducted mainly by trucks although rail or barge movements especially for the R-F and F-F vectors are possible.

Box 6-1 Classification of Common Freight Flows [based on Niles MTI (50)]

- External - Factories (E-F): Manufacturing process inputs (raw materials and parts) flow from sources external to the region direct to factories. On the reverse, factory output (finished goods and subassemblies) is transported by truck to destinations outside of the region (external).
- External - Intermodal (E-I): This vector represents the flows cargo from areas outside the region in order to use the regional intermodal terminals (seaports, airports, and rail yards) that may serve larger inland areas than the immediate region.
- External - Warehouses (E-W): Distribution centers (DCs) may send or receive goods beyond the boundaries of the region in which they are situated.
- Factories - Factories (F-F): When two factories that are part of the same supply chain reside in the same region this vector occurs.
- Factories - Intermodal (F-I): Factories that ship their output, or receive their input with an intermodal transfer within the region.
- Factories - Warehouses (F-W): Factories that receive raw material and parts input from warehouses, or send their output of finished goods or parts to local warehouses.
- Factories - Stores (F-S): Facilities that ship directly to retail locations within the region without intermediate warehousing.
- Warehouses - Intermodal (W-I): DCs send and receive cargo through intermodal terminals with final destination or origin that is external to the region.
- Warehouses - Stores (W-S): A common vector of freight transport from the warehouse to the store. Reverse direction can be expected for returns, overstocks, as well as for transfer to other retail facilities for which a given product is in greater demand.
- Warehouses - Residences (W-R): This vector represents the B2C connection; mail, express packages, and internet orders arrive at residential locations originating from warehouses and sorting centers rather than stores. The reverse direction represents returned items, outgoing mail. In a sustainable setting this direction would also serve for the collection of products to be reused in the manufacturing process.
- Stores - Residences (S-R): Usually appliance stores deliver goods directly to residential locations.
- Residences - Damp (R-D): The flows of used products and waste to a refuse and/or recycling facility.
- Damp – Factories (D-F): This vector shows the flow of factory waste and on the reverse recycled material and products that go back in the production process.
- Raw material – Factories (M-F): The transfer of products from raw material sources within the region to factories for processing as inputs. The reverse signifies the production of inputs like fertilizers or machine parts for the raw material source.
- Raw material – External (M-E): This vector represents the export of raw material to external regions.

The regional models for freight flows that will be presented in the rest of the chapter are founded on this basic, yet realistic, model for freight flows. More detailed modeling can investigate the relative importance of individual flows and in case some flows are considered as inconsequential they can be dropped from the region-specific models.

6.2 Region A: One region, one product model

This is perhaps the simplest model of a regional freight transport system that can be created; it has no direct practical application in real-world systems but it provides a test-bed for thinking through the architecture creation process and its implications. This model consists of one region (Region A). The region has one city and demand for one product that requires certain manufacturing processes and raw materials. The use of the product results in waste that can be partially reused if so desired.

In the following, we create the regional architecture from scratch based on the first two phases of the CLIOS process: 1) Representation and 2) Design, Evaluation and Selection. We follow the steps of the CLIOS process for architecting the freight transportation, supply chain, and organizational structure of the very simple Model A shown in Figure 6-2. Our objectives in this exercise are:

- (i) identify the main subsystems and their components of the generic RSTP/SCM system,
- (ii) set the stage for the evolution of more complex models that are scalable, and
- (iii) create a detailed process that can be used for application to real-world cases.

Note that the system in this case is a blank slate which is of course not the case in the real world. However, it will allow us to explore various possible architectures and design parameters.

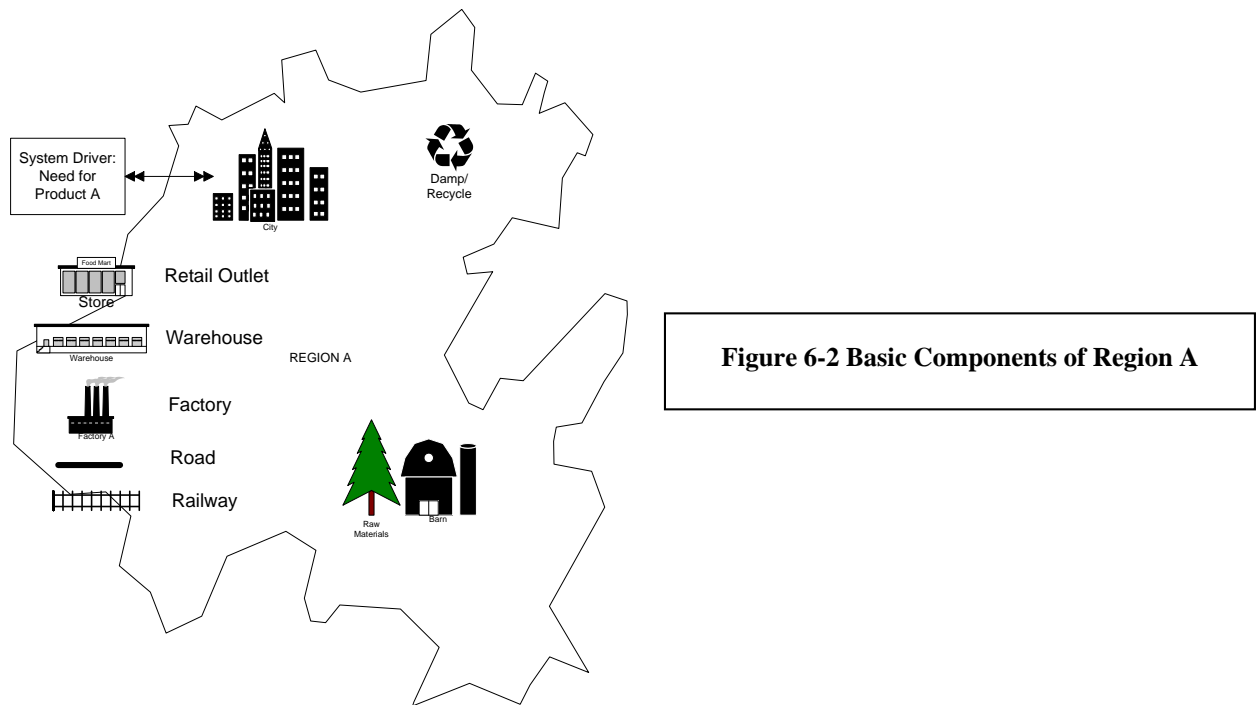

Figure 6-2 Basic Components of Region A

6.2.1 Representation Phase of the CLIOS Analysis for Region A

6.2.1.1 Step 1: Describe System: Issue Checklist and Goal Identification

The system's region contains one major population center that has demand for a product A. As a starting point we assume that the production and distribution of the product will be done through private initiative while infrastructure provision can be either public or private.

The system is designed with the main objective of satisfying the demand for product A while producing acceptable external costs. A subsequent objective is to maintain enough capacity to satisfy passenger needs through access to stores and workplace. An initial list of primary and secondary goals that operationalizes the definition of sustainable transportation policy goals given in Section 3.2.1 can be seen in Table 6-1.

Goals

Table 6-1 Goal Identification for Region A

General	Primary System Goals for Region A
	Satisfy the demand for product A
	Provide sufficient capacity for freight and passenger transportation
	Keep externalities within tolerable levels
Private Sector	Secondary Goals for Region A
	Profit maximization
	Efficient operations
	Low production cost
	Tertiary Goals for Region A's Supply Chain
	Low inventory
	Fast Delivery
	Reliability
	Flexibility
	Transparency/ real-time information
Public Sector	Secondary Goals for Region A
	Positive Economic Impact on Growth
	Acceptable environmental external costs
	Safety
	Low operating costs
	Low capital costs
	Efficient operations
	Passenger transport retains enough capacity

In addition to the list of goals the CLIOS process suggests the creation of a *checklist* of important issues that are prominent in the system and essentially substantiate the problem; that is why the CLIOS analysis is conducted. As discussed in Section 5.3.1 this checklist will act as reminder for the rest of the process and provide a fast-check on whether the issues are really being addressed during the process and most probably will be updated as system understanding increases. Since this is a thought experiment the checklist provided below in Table 6-2 is imaginary and based on issues faced by regions in the real-world.

*Issue
Checklist*

Table 6-2 Indicative Issue Checklist for Region A

Competition among firms
Competition among regions
Congestion
Infrastructure maintenance
Equitable pricing of infrastructure use
Externality pricing
Utilization of new technologies
Optimal infrastructure expansion
Increasing consumer expectations / consumerism
Optimal supply chain development
Economic growth and wealth based on material transactions / Dematerialization of the economy
Network accessibility
Resource depletion
Environmental degradation

6.2.1.2 Step 2: Identify the Major Subsystems of the Physical Domain and Major Actor Groups of the Institutional Sphere

As major subsystems in this case we will use the ones commonly identified previously (see Chapter 5): transportation, economy, land use, environment and we will *add* a manufacturing/supply chain subsystem.

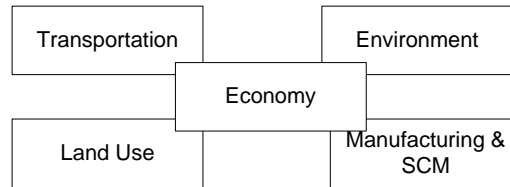

Figure 6-3 Major CLIOS Subsystems for Region A

The major actor groups in the institutional sphere³⁹ for our generic Region A can be initially represented simply as the public and private sector. More detailed grouping would be warranted in a real-world example.

6.2.1.3 Steps 3 & 4: Components and Links for Physical Domain and Institutional Sphere

Step 3: Populate the Physical Domain and the Institutional Sphere in the CLIOS Diagram

Step 4A: Describe Components of the Physical Domain and Organizations on the Institutional Sphere

Step 4B: Describe Links among Components and Organizations

In this set of steps we create the basic CLIOS diagrams that represent the system. For presentation clarity Steps 3 and 4 – CLIOS diagrams and component and link description – are bundled. A brief description of links and components accompanies each diagram that represents Steps 4A and 4B (Figure 6-4 to Figure 6-9). In order to clarify the interconnections among the components and facilitate architecting we use, as a supplementary tool, a link matrix (see Table 6-3) that represents the specific interactions among the components in a condensed tabularized format.

Transportation Subsystem⁴⁰

We begin by representing the transportation subsystem. The components and their interactions are shown in the CLIOS diagram (Figure 6-4). The diagram structure categorizes the components into loosely connected areas. For clarity only the basic links are shown and the rest are represented in detail in the link matrix as shown in Table 6-3 .

Transportation Subsystem Component Description

The basic components include elements of the infrastructure (road and rail networks), the fleet that uses the infrastructure, and the actual transport flows which are shown as elliptical shapes. The projections from the institutional sphere, that is regulations and private strategies, are shown as rectangles. The influence that location of major entities exerts on transport is depicted through

³⁹ To refresh the reader's memory the institutional sphere is a notional sphere that encompasses the planes of the physical subsystems. It consists of organizations that through their actions control, or "contain," parts of the physical system.

⁴⁰ The order the subsystems are presented does not necessarily represent their relative importance.

common drivers (rhombic shapes) in the land use area. Finally, the impact of the demand for the product and the output are shown as common drivers in the economy area.

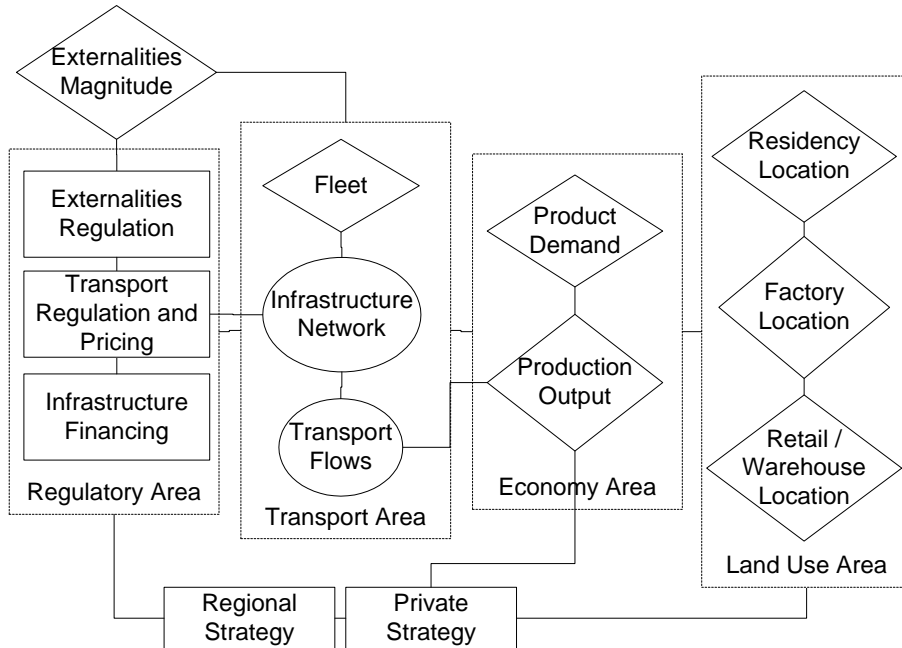

Figure 6-4 CLIOS Diagram of the Transportation Subsystem

The demand for products drives the output of production which in turns results in transport flows of freight. Passenger transport flows are also present as trips to work or to retail outlets. The location of the factories, residences, warehouses and outlets influence the layout of the infrastructure network as well as the main type of flows that originates and terminates in each location. The transport flows and the engine types of the vehicle fleets influence the type and magnitude of environmental externalities, mainly through their emissions. At the same time the transport flows when they reach or exceed the capacity of the infrastructure create congestion externalities. In order to mitigate those externalities regulatory and pricing schemes can be devised. Pricing can also influence infrastructure financing that affects the construction of new connections and the maintenance of the existing network.

Economy Subsystem

The economy subsystem is simpler in structure. In addition to components established previously in the transportation subsystem, Figure 6-5 introduces the elements of economic output and trade regulations that influence the specific subsystem.

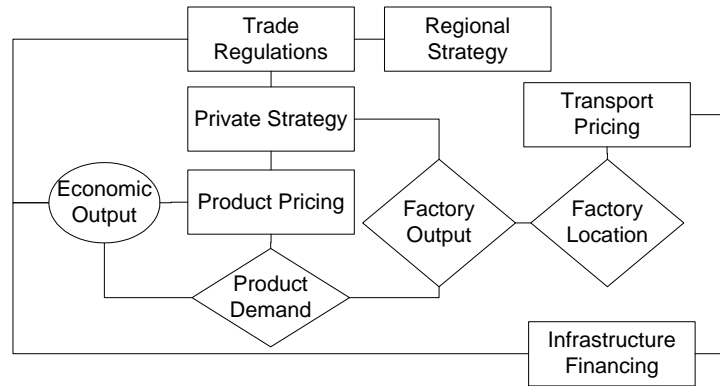

Figure 6-5 CLIOS Diagram of the Economy Subsystem

Economy Subsystem Component Description

In this simplified model, the main driver of the subsystem is the product demand as well. The equilibrium of product pricing and product demand creates surpluses that drive the economic growth of the region. Product pricing and product output can be influenced by trade regulations (for example anti-monopoly regulations) as well as by the private sector’s strategies. At the same time the product output and the location of production facilities create demand for transport services that can drive transportation prices and ultimately the financing of infrastructure.

Land Use Subsystem

In the land use subsystem, the projection from the institutional sphere of land-use regulations is added as well as the element of location of the damp / recycling site.

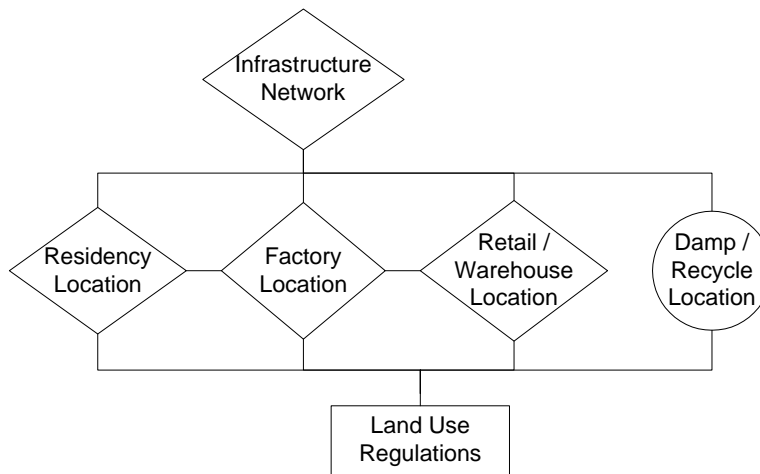

Figure 6-6 CLIOS Diagram of the Land-use Subsystem

Land-use Subsystem Component Description

This subsystem simply depicts the interrelation of location of the residencies, retail outlets, warehouses, and factories. The infrastructure network connects those elements and their establishment can be partially controlled through regulatory measures. Many complex interactions take place within this subsystem in the real world due to the ambivalent forces at work; for example factories may be located close to residencies in order to offer short commutes to their workers but their existence makes the area less desirable for residencies. Another example calls for retail outlets to be within the communities but the availability of auto-based mobility and the higher value of land at the center of the cities pushed large outlets to the outskirts of cities in a

reinforcing loop that lead to current urban sprawl phenomenon. Here we just present the potential links without delving into such details.

Environment Subsystem

With the environment subsystem three new elements are introduced: ecosystem and habitat loss, which represent the environmental impact of the taking of land for other uses, manufacturing process emissions and wastes, and vehicle emissions.

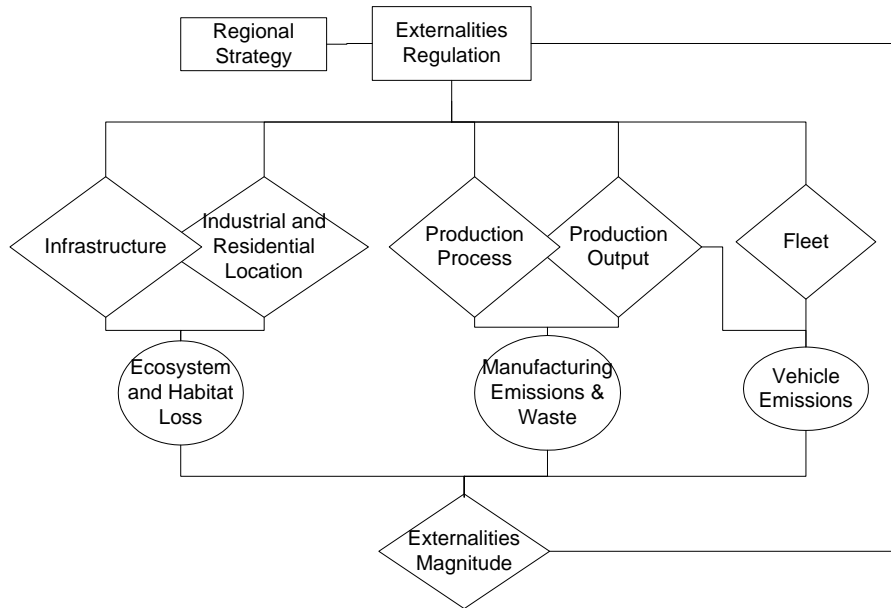

Figure 6-7 CLIOS Diagram of the Environment Subsystem

The environment subsystem depicts the direct impact that the activities of the freight transport system have on the surrounding environment. Infrastructure networks as well as residential and industrial complexes take up space that used to be part of natural ecosystems. This taking of space is shown on the interaction on the left. At the same time the choice of the production processes and the amount of output impact the type and quantities of generated effluence. Finally, the transport of the products themselves produces emissions. These three impacts are consolidated in the “Externalities Magnitude” common driver. This in turn drives the regulation of those externalities which is of course moderated by the strategy of the region. Of course, in practice externality regulations are instituted by different organizations but this does not contradict the generality of the above representation.

*Environment
Subsystem
Component
Description*

Manufacturing and SCM Subsystem

The last subsystem we introduce is the Manufacturing and SCM subsystem. It is a complicated subsystem which, similarly to the previous subsystems, is simplified in this representation. This simplification allows for easier representation and makes the integration of SCM into RSTP possible without sacrificing practical applications.

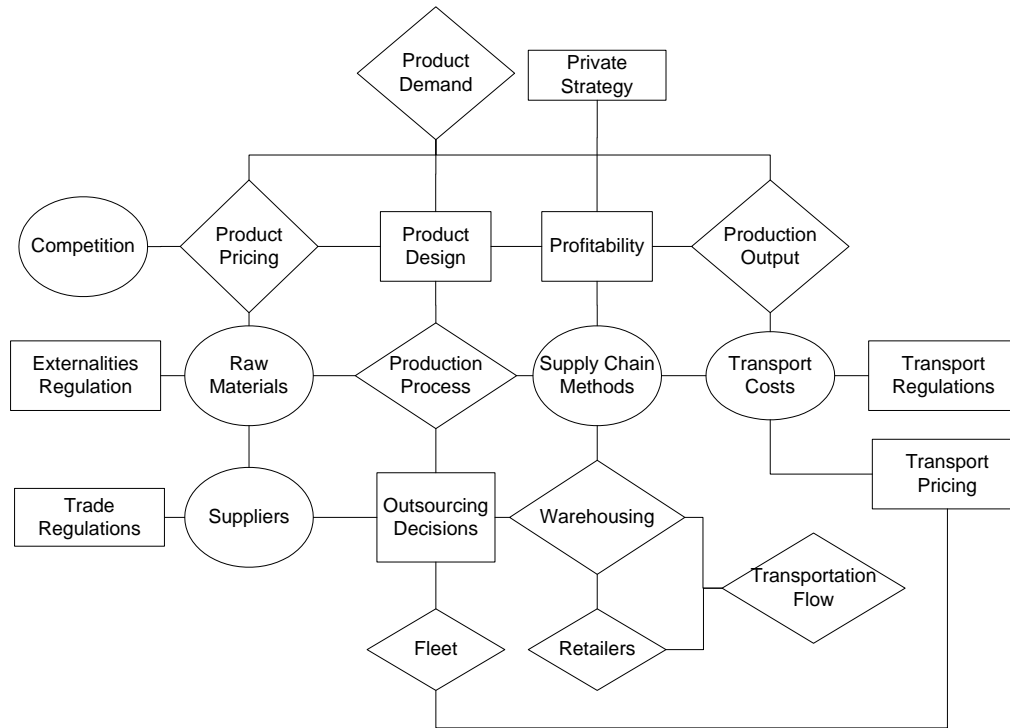

Figure 6-8 CLIOS Diagram of the Manufacturing and SCM Subsystem

*Manufacturing
Subsystem
Component
Description*

We assume that the demand for product A is enough to attract corporate interest. The interested company is expected to follow a product design and development process along the lines provided by Ulrich and Eppinger (12). Decision points will be faced regarding raw materials, process type, suppliers, potential for outsourcing, delayed differentiation features etc. These decisions will be constrained by considerations like externalities regulation, transport pricing, expected product demand etc. Final product pricing and production output will be influenced by trade regulations and existing or potential market competitors. Decisions on supply chain methods (like out sourcing, just-in-time (JIT) delivery, cross-docking etc) will influence the operation and location of retailers and warehouses as well as the transportation configurations from suppliers and to the retailers. Eventually, this will affect transport flows; if for example a JIT system is initiated to reduce inventory costs it is expected that it will translate in more frequent shipments of goods using smaller vehicles eventually increasing vehicle flows.

Institutional Sphere

Finally we *map* the institutional sphere so that the projections of regulations and strategies on the subsystem layers are tied with the various levels of government and private actors.⁴¹

⁴¹ The institutional sphere includes only the institutions (oval shapes) while their policies (rectangular shapes) are part of the previously examined subsystems. In this representation we include both as a way to tie the various 2-dimensional layers together.

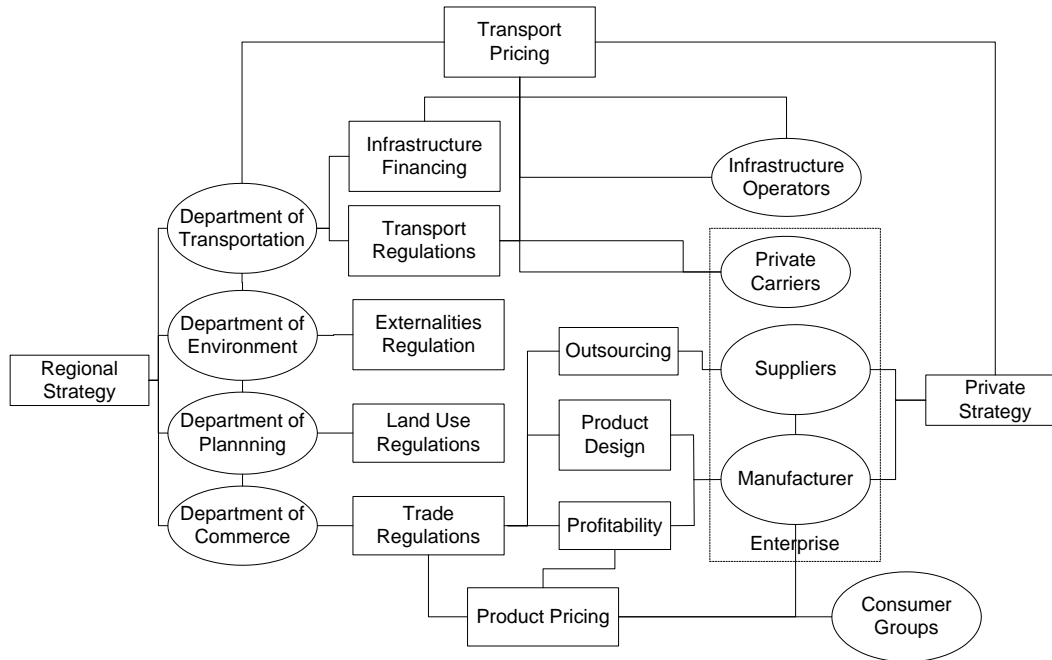

Figure 6-9 CLIOS Mapping of the Institutional Sphere

Since the system is a simplification and not a real world case, on the public side we use generic names to identify the usual sections of government that regulate each sector.⁴² The Department of Transportation influences infrastructure financing and transport pricing and possibly some regulations regarding vehicle emissions. The Department of Environment regulates emissions, waste disposal, and use of environmentally sensitive land across the board. The Department of Planning controls land use and zoning laws and finally the Department of Commerce oversees market functioning. These departments may be guided by a common strategy given as political mandate shown as “Regional Strategy.”

*Institutional
Sphere
Organizations
Description*

On the private side, the elements used are simpler with generic classes to represent suppliers, manufacturers and carriers. These elements are encased to signify the potential Enterprise perspective, a vertical integration theme presented by Allen et al. (35). Consumer groups and infrastructure operators are also represented as potential actors influencing the system.

Link Matrix

Even with such a simplified model the number of links and components rises quickly and makes visual representation unwieldy and cluttered. As a way to represent this complex system in a concise and complete manner we propose the use of a “link matrix.” The link matrix is based on the Design Structure Matrix (DSM) methodology, primarily developed for product design and system analysis (58). It provides a summary of the links as well as tools for analyzing the structure. Each element is assigned to a column and a row. When an element influences another element an X denotes this relationship on the appropriate square.

⁴² In this we follow the notation of the U.S. government by name the sections of government as departments. Our notation is consistent based on function so for example we use Department of Environment instead of Environmental Protection Agency. Hence this terminology is interchangeable with ministries.

The CLIOS diagrams have heuristic advantages and intuitive appeal but the link matrix can be complementary to the diagrammatic representation because it offers:

- (i) *concise representation of the system*. Diagrams can become really complex, cluttered visually resulting in suppression of links, and take up many pages. The link matrix can provide information at a glance without the need to suppress linkages.
- (ii) *ability to manipulate it algorithmically*. The link matrix, unlike diagrams, offers a tool where information about the system can be drawn immediately (e.g. find the number of links originating from any component, or find the components that influence the greater number of other components, or make a causality diagram starting from any component). In addition DSM analysis (based on clustering as discussed in 6.2.1.4.1) can be applied.
- (iii) *ability to clearly encode additional information*. The link matrix is based on directed vectors of influence (arrows would be needed to show this information on a diagram), the “strength” or importance of any link can be also indicated based on a predetermined scale (in our example we simply distinguish between strong and weak links), information on the type of link (e.g. financial, material, energy, command, etc) can be added on the matrix using additional encoding.⁴³

The Link Matrix is a square matrix with identical elements in both rows and columns. Each component is presented in the matrix as a part of the diagonal with the number that corresponds to its row (and column). An off-diagonal mark signifies the dependency of one component to another. Reading down a column Y shows all components that are directly influencing component Y (Y is dependent on the elements that are marked). Scanning across a row X reveals what other elements the element X influences. Thus, in Table 6-3, element 1 (Road Network), to pick one example, is depended on elements 2, 3, 4, 5, 9, 11, 17, 19, 20, 24, 39 and influences elements 2, 3, 4, 5, 6, 7, 8, 10, 12, 16, 20, 32, 33.⁴⁴

Reading the
Link Matrix

Steps 3, and 4 of the CLIOS process are concluded with the completion of the CLIOS Diagrams and the creation of the Link Matrix to represent the interconnections among the components. The next step uses this representation to draw insights for the system.

6.2.1.4 Step 5: Seek insight about the system behavior.⁴⁵

How one actually achieves the objective of this step – that is to gain insight on the system – will usually differ among CLIOSs as will the depth of the insights. In the following we propose that there can be at least four structured ways of approaching the insight generation: (i) expert interaction, (ii) Link Matrix Analysis, (iii) Systems Dynamics, and (iv) System Architecture decomposition. While any of the four can be used in isolation, the best results can be obtained by combining the insights from one method to the next and stopping when the researchers consider

⁴³ The link matrix *does not* provide a good means of representing usefully information on the functional form and speed of the link influence (if for example the influence is a step, linear, or exponential function). This type of encoding can be done with dynamic models like the system dynamics one presented in the next section.

⁴⁴ The description of DSM by Browning (60) was used as basis for this description of the link matrix.

⁴⁵ Quantitative insights into the system can be gained through simulation of the system and experimentation. Since the creation of the simulation is deferred for the PhD dissertation, only qualitative insights are sought in this section.

that there is enough information to proceed to the next steps for the current iteration of CLIOS or in the worst case, planned allocation of research effort and funding runs out for this step.

The first and most widely accepted one normally takes place from the beginning of the process. It involves gauging the knowledge of stakeholders and experts on the system through personal interviews and questionnaires. Since our system at its current stage is mainly a conceptual model we will rely on the latter three ways of understanding system behavior and finding the major leverages in the system. In the next three sections we will present each method and discuss the insights gained.

6.2.1.4.1 *Link Matrix Analysis*

In order to visualize system behavior using the link matrix discussed previously, we need to process it so that the internal structure can become visible. One way to do so is to ascribe weights on the links according to their relative importance and proceed to cluster the matrix in a way that tight interconnections are revealed. The analysis tools designed for DSM are focused on partitioning and clustering the matrix in a way that makes it simpler and separates the elements that are connected with loop interactions. Browning (60) defines the objective of clustering as “maximiz[ing] interactions between elements [components] within clusters ... while minimizing interactions between clusters.”

Weighted Link Matrix Although all the interconnections shown are part of the system as presented in the link matrix, not all of them have the same weight. To facilitate the task of clustering and make it reflect the real-world interactions a simple weighing scheme of the importance of each link is employed. Important links are noted with the bold capital X while less important ones with a small x. The resulting weighted link matrix can be seen in Table 6-4.

Clustering the Link Matrix We used the trial version of PSM32, a commercially available software for DSM by Problematics (59), we tried to cluster this CLIOS. We based our attempts on the weighted matrix simply substituting 1 for x (shown in lighter shade) and 2 for X (shown darker). The results of this first-order clustering and some manual re-ordering can be seen in Table 6-5. Several clusters of tight interconnections surfaced as anticipated; these are marked as rectangles with heavier borderlines. In addition, secondary clusters, or blocks, appear that are indicative of interactions from one main cluster to another; these are marked with a dashed borderline.

In order to better identify the clusters we indicated the subsystem where each component can be found. In the case of common drivers the first is the subsystem where the component is directly related with along with the more important secondary one.

Table 6-5 A Possible Clustering of the Link Matrix for Model A

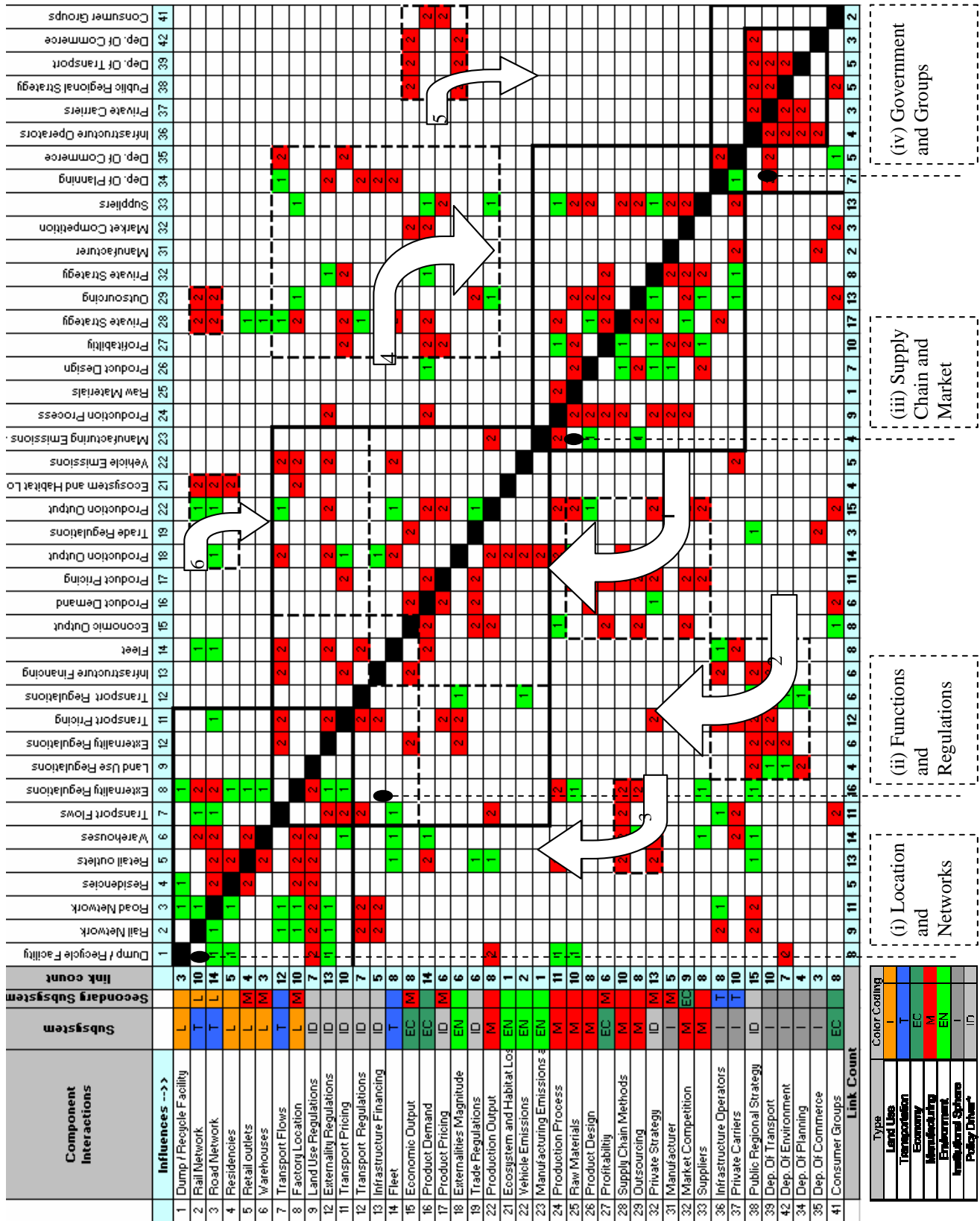

The four main clusters of tight interactions that appear in Table 6-5 are: (i) Locations and networks, (ii) Economic functions, market, and regulations, (iii) Supply chain, and (iv) Government and groups.

Analyzing the Link Matrix

What becomes apparent from Table 6-5 is that this system representation indicates a high degree of integration. This lack of “modularity” indicates that any planning effort should be based on as comprehensive models as possible – one cannot expect to change one aspect or one cluster of the system without changing other clusters. These types of interactions are shown as block arrows in the table in addition to clusters across the main diagonal. These off-diagonal clusters or “blocks” are marked by an arrow that indicates the direction of influence from cluster to cluster. The more significant blocks that emerge are: 1. the influence of supply chains on the markets (Cluster (ii)); 2. The influence of government on the regulations (upper left of Cluster (ii)); 3. The influence of supply chains on locations (especially retailers, warehouses, and factories of Cluster (i)); 4. The influence of regulations and functions (Cluster (ii)) on supply chains; and 5. The influence of economic output and externalities on government.

Table 6-6 Ranking of Components by Outgoing and Incoming Links

Components	Subsystem	Secondary Subsystem	Influence Link Count	Influenced by Link Count	Ranked by Number of Influential Links					Ranked by Number of Influenced Links				
					1	2	3	4	5	1	2	3	4	5
1 Dump/Recycle Facility	-	-	3	8	35 Public Regional Strategy	IC		15	4	28 Supply Chain Methods	IC		10	17
2 Rail Network	T	-	10	9	3 Road Network	T	L	14	11	9 Factory Location	-	IC	10	15
3 Road Network	T	-	14	1	6 Financial Markets	FC		14	3	22 Production Output	IC		3	15
4 Residences	-	-	5	5	12 Externalities Regulations	IC		13	3	10 Externalities Magnitude	EN		3	14
5 Retailers	-	IC	4	13	22 Private Strategy	IC	IC	13	3	8 Warehouses	IC	IC	3	14
6 Warehouses	-	IC	3	14	7 Transport Flows	T		12	11	29 Outsourcing	IC		3	13
7 Transport Flows	I	-	12	1	24 Production Process	IC		11	4	23 Suppliers	IC		4	13
8 Factory Location	-	IC	10	16	2 Rail Network	T	L	10	3	3 Retail Outlets	-	IC	4	13
9 Land Use Regulations	IC		7	4	3 Factory Location	-	IC	10	6	1 Transport Piling	IC		10	12
10 Externalities Regulations	IC		13	6	1 Transport Piling	IC		10	2	3 Rail Network	T		4	11
11 Transport Pricing	IC		10	12	25 Raw Materials	IC		10	1	7 Transport Flows	T		12	11
12 Transport Regulations	L		7	6	26 Supply Chain Methods	IC		10	1	17 Production Process	L	IC	3	11
13 Infrastructure Financing	IC		5	0	27 Private Carriers	I		10	5	27 Profitability	EC	IC	3	10
14 Fleet	I		8	8	25 Dep. Of Transport	I		10	2	24 Production Process	IC		1	9
15 Economic Output	EC	IC	8	8	32 Market Competition	IC	EC	9	3	2 Rail Network	T		10	9
16 Product Design	EC		11	6	11 Fleet	T		9	3	32 Private Strategy	IC	IC	13	8
17 Financial Markets	IC	IC	6	1	15 Economic Output	EC	IC	8	3	14 Fleet	T		3	8
18 Externalities Magnitude	EN		6	14	22 Production Output	IC		8	15	15 Economic Output	EC	IC	3	8
19 Trade Regulations	L		8	2	26 Product Design	IC		8	7	1 Dump/Recycle Facility	-		3	7
20 Production Output	IC	IC	8	15	23 Outsourcing	IC		8	13	28 Product Design	IC		3	7
21 Ecosystem and Habitat Loss	EN		1	4	22 Suppliers	IC		8	12	36 Infrastructure Operations	I	T	3	7
22 Vehicle Emissions	EN		2	5	35 Infrastructure Output	I		8	7	18 Product Design	IC	IC	14	6
23 Manufacturing Emissions and Waste	EN		1	4	41 Consumer Groups	EC		8	2	12 Externalities Regulations	IC		13	6
24 Financial Process	IC		1	5	3 Land Use Regulations	IC		7	4	17 Transport Regulations	IC		7	6
25 Raw Materials	IC		10	1	12 Transport Regulations	IC		7	2	19 Infrastructure Financing	IC		5	6
26 Product Design	IC		8	7	42 Dep. Of Environment	I		7	2	24 Private Carriers	I	I	10	5
27 Profitability	EC	IC	6	10	17 Product Pricing	IC	IC	6	11	42 Dep. Of Environment	I		7	5
28 Supply Chain Methods	IC		10	17	18 Externalities Magnitude	EN		6	14	4 Accidents	-		5	5
29 Outsourcing	IC		8	13	18 Trade Regulations	IC		6	3	34 Dep. Of Planning	-		4	5
30 Private Strategy	IC	IC	13	8	27 Profitability	EC	IC	6	10	22 Vehicle Emissions	EN		2	6
31 Financial Markets	I	IC	5	2	4 Accidents	I		5	1	38 Profit Regional Strategy	IC		15	4
32 Market Competition	IC	EC	9	3	10 Infrastructure Financing	IC		5	2	3 Land Use Regulations	IC		7	4
33 Suppliers	IC		8	12	21 Manufacture	I	IC	5	2	21 Ecosystem and Habitat Loss	EN		1	4
34 Infrastructure Output	I	T	8	7	3 Retail Outlets	-	IC	4	13	23 Manufacturing Emissions and	EN		1	4
35 Private Carriers	I	T	10	6	3 Dep. Of Planning	I		4	5	29 Dep. Of Transport	I		10	3
36 Public Regional Strategy	IC		15	4	1 Dump/Recycle Facility	-		3	3	32 Market Competition	IC	IC	3	3
37 Dep. Of Transport	I		10	3	6 Warehouses	-	IC	3	14	19 Trade Regulations	IC		3	3
38 Dep. Of Environment	I		7	5	27 Dep. Of Commerce	I		3	3	35 Dep. Of Commerce	I		3	3
39 Dep. Of Planning	I		4	5	22 Vehicle Emissions	EN		2	5	41 Consumer Groups	EC		3	2
40 Dep. Of Commerce	I		3	3	21 Ecosystem and Habitat Loss	EN		1	4	31 Manufacturer	I	IC	3	2
41 Consumer Groups	EC		8	2	23 Manufacturing Emissions and	EN		1	4	25 Raw Materials	IC		10	1

Beyond knowing how clusters form and influence each other we can identify individual “hub” components. “Hub” components are those with the greater number of outgoing and/or incoming links. Ranking of all components is shown in Table 6-6. The most “influential” components appear to be the public regional strategy, the road and rail networks, the product demand, and the private strategy. Supply chain methods, location of manufacturing, production output, magnitude of externalities, and outsourcing seem to be the more influenced components. It should be noted that when ranking only by high impact links (2) the order does not change substantially.

The components with the higher rankings are among the ones that planners should consider when finding ways to affect change. Of course the way that the system is impacted by change in one of those components may not be intuitive; for this reason it is useful to have a dynamic model of the system like the one suggested in the next section.

Insights gained by using the Link Matrix (LM) Analysis:

Clustering: allows us to understand which components have greater interdependency. In case of change in one component the components within the cluster will be directly affected.

Ranking: The components higher in the list are the ones that may provide the greater leverage for affecting change.

6.2.1.4.2 System Dynamics

The representation of a system through System Dynamics follows the procedure and notation described in detail by Sterman (61). In the following we will discuss the qualitative model for the most important interactions in our Model A Region system.

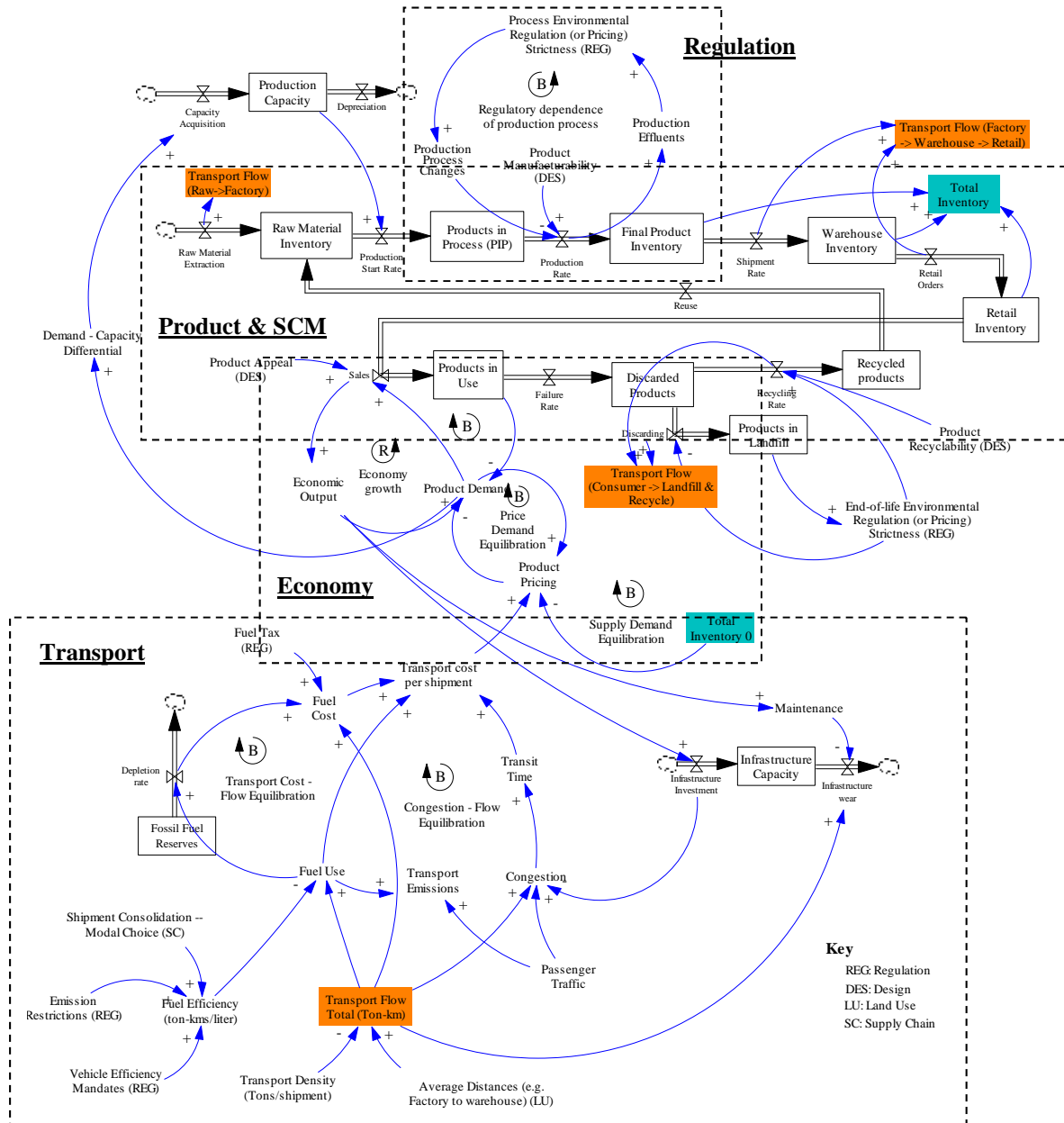

Figure 6-10 Complete Systems Dynamics Model for Model Region A (All SD figures prepared using Vensim ® PLE Student Version (62))

Notation: Arrows indicate causal connections. A positive arrow indicates a positive correlation between origin and destination (if origin value increases destination value increases as well). Variables that are in rectangles represent stocks and double-line arrows represent flows. In this model stocks and flows are used to represent the transformations and accumulations of physical

objects but they can be used in general for representation of financial assets and other non-physical entities. The letters B and R mark balancing and reinforcing loops accordingly and are supplemented by comments that explain the main character of the loop.

Figure 6-10 provides the full view of the model. In order for it to become clearer we will break it down into parts and discuss how they tie together. For clearer presentation some of the less important connections with the variables from other parts of the model will be suppressed.

Model
Explanation

At the heart of the model is a chain of stocks and flows that represent a full material product life cycle (Figure 6-11). The various levels of raw material extraction, actual production, inventory acquisition, sales, discarding, and re-use are represented. Each of the flows that utilize the transport network translates into actual transport flow marked by the orange boxes. Finally, the inventory levels are added as total inventory (blue box).

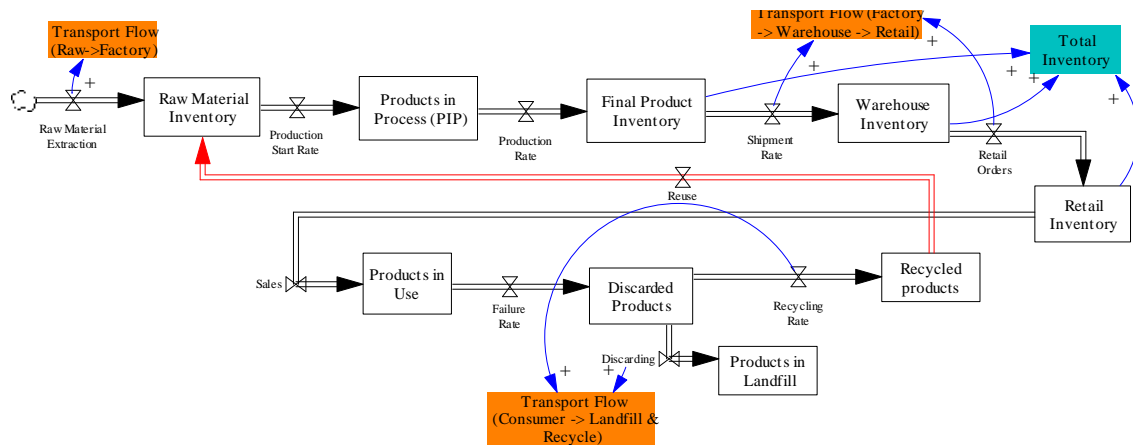
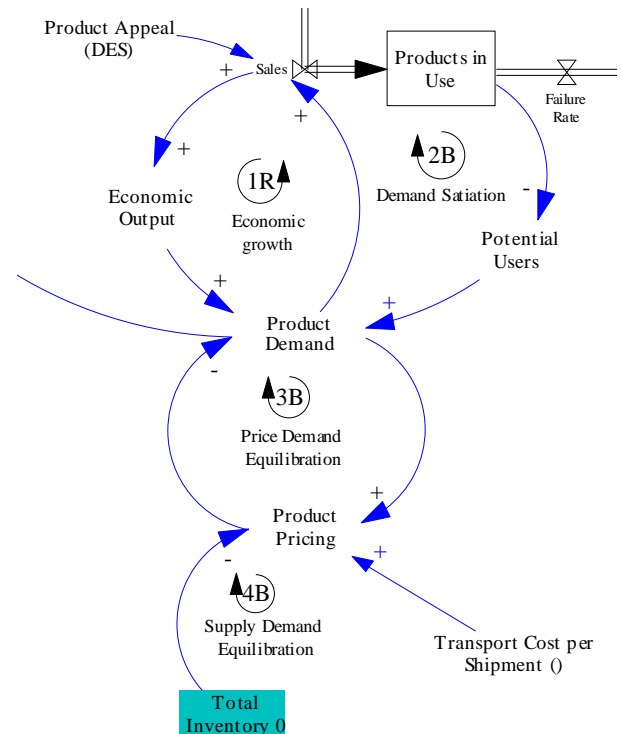

Figure 6-11 Material Production Life Cycle & Resulting Transport Flows

The product cycle is directly tied to economic performance as shown in Figure 6-12. There are four loops that are active in this part of the model: (1) as the product sales increase so does economic output and product demand, but (2) as sales increase the stock of products in use the demand increase is slowed since a greater percentage of total potential customers are satisfied. Finally, (3) and (4) are adjusting the price to reflect demand and inventory but transport cost per shipment is also influencing the final price.

Economic activity influences capacity of two procedures: by directly giving a signal to capacity changes on the manufacturing side (shown in Figure 6-13) as well as by allowing infrastructure maintenance and expansion through revenues from taxing and/ or transport pricing (Figure 6-14).



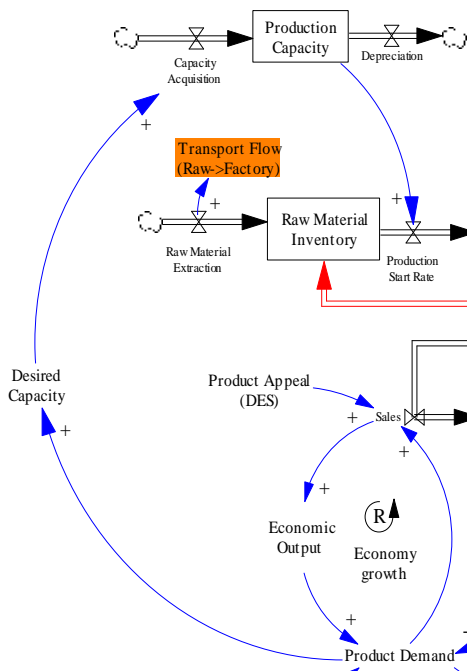

Figure 6-13 Manufacturing Capacity Influenced by Market

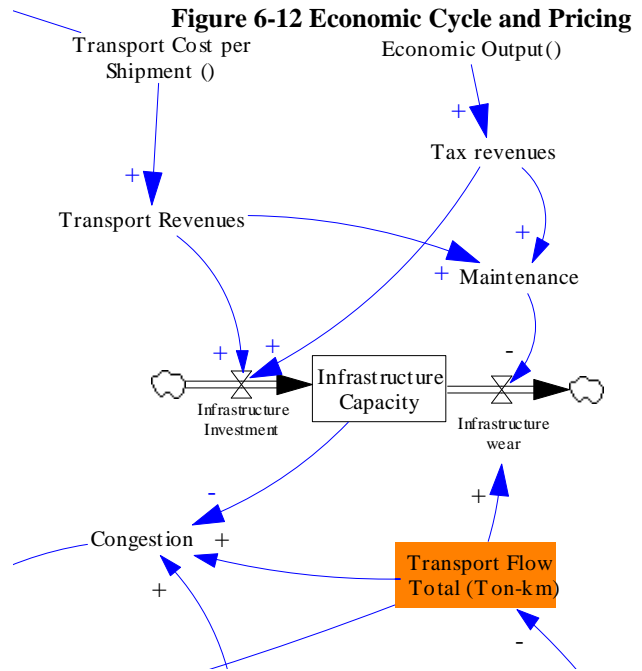

Figure 6-14 Network Infrastructure Capacity Influenced by Flow (as wear) and Maintenance (coming from transport pricing (indirect Flow influence) and economic output)

A large part of the model consists of the representation of the transportation flows influences on the system. These are shown in Figure 6-15.

The two main connecting variables with the rest of the model are the amount of flow (indicated as transport flow) and the transport cost per shipment that in turn influences pricing.

These two variables are connected with loops that represent fuel use and fuel cost, emissions restrictions and pricing, congestion, as well as the bigger loop that calibrates total production based on demand that is in turn affected by transport cost. Other influences

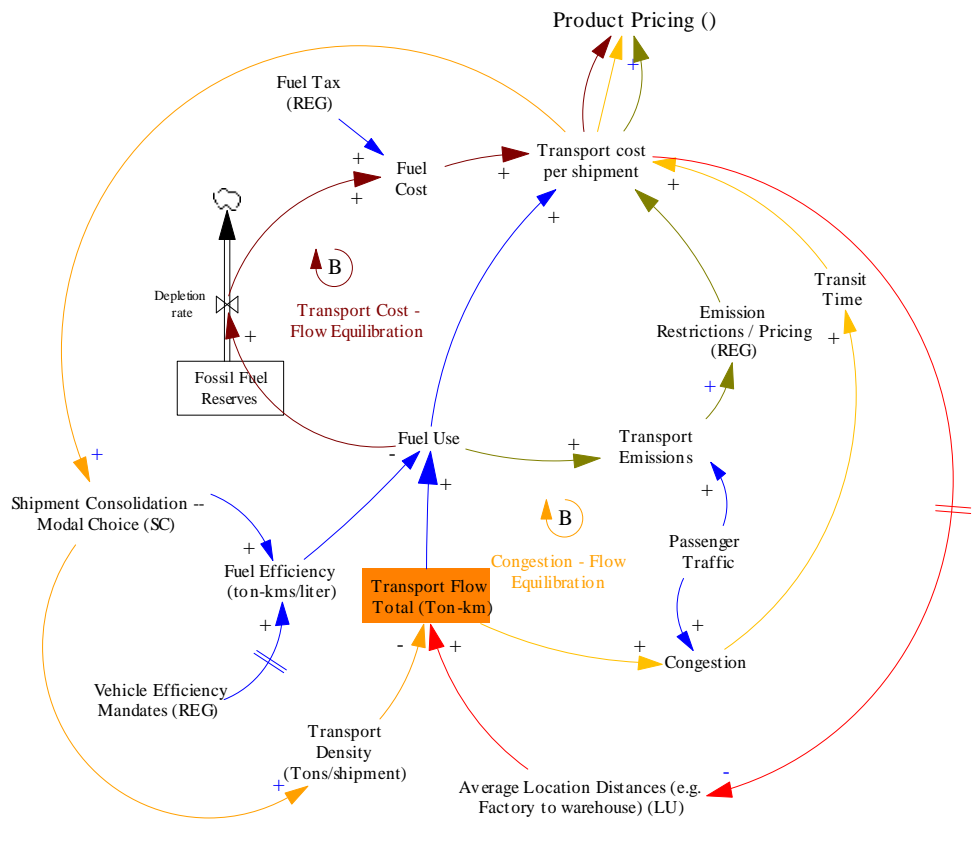

Figure 6-15 Transport Flows Influence on Emissions, Congestion, Fuel Use, and Location and ultimately on Transport Pricing

include the long term effects of transport pricing to relocation of facilities as well as the effects of passenger traffic both on congestion and emissions.

Finally there are a number of variables that represent regulatory influences (marked by REG in the model). In Figure 6-15 these are: fuel taxes, vehicle fuel efficiency regulations, and emissions restrictions. Another regulatory influence is the environmental regulation that is directed on production process (shown in Figure 6-16). Depending on the success of implementation the production rate can even be increased.

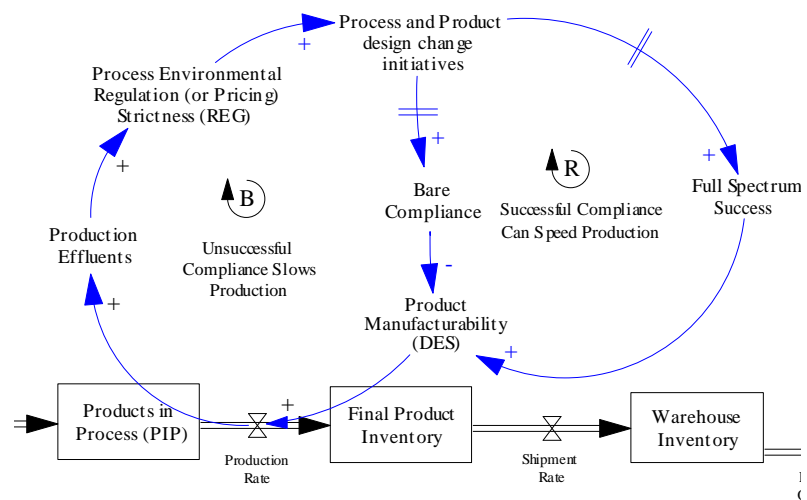

Figure 6-16 Environmental Regulation on Production Process

SD-based Analysis The major addition of the conceptual SD model over the Link Matrix model is that it allows for a focused look on the more important *functions* of the variables/elements as clearer view of the loop interactions and a sense of dynamic development through time. This latter feature is SD's greatest advantage and can mainly be utilized through simulation (future development into PhD dissertation). Of course, quantification into a simulation model may not be widely acceptable across stakeholders initially and may be difficult since many components are qualitative. Even with these caveats though simulation, if used as a suggestive and not predictive tool, and if reasonably substantiated can greatly enhance the understanding of the system.

Using a calibrated model and simulation, the researcher can identify the relative impact of the various regulatory influences. Given that there are many embedded loops, the model can measure the sensitivity of the major variables (transport flow and economic output) in changes in the other model parameters. Of special interest are the effects of parameters that exhibit delayed change (infrastructure development, delays from measuring of pollution to implementing regulation, or from depleting fuel reserves and affecting fuel price) or of the effect of regulations that may have ambivalent impact or be highly contested. For example, a policy to drive freight off the road (e.g. through pricing or mandating) may have negative impact on revenues for maintaining the existing network. This policy could be resisted not only by the shippers but by road transport departments as well that would disapprove any restrictions on their revenues.⁴⁶

Insights gained by using the Systems Dynamics (SD) Analysis:

Dynamic understanding: SD modeling offers understanding of the system over time and over relative importance of variables.

Focusing on function: The SD model clarifies the interactions that in the Link Matrix are shown as clusters and brings forward the more important ones.

Quantification of Influence: Allows for quantification of relative influence of variables for testing various policies.

⁴⁶ A similar effect has been discussed in the EU concerning truck road pricing as indicated in an OECD report (66) – A. Priebis and A.D. Wesbuer pg. 26 .

6.2.1.4.3 Systems Architecture (SA)

The third approach we used for getting insights from the system is a methodology that derives also from product development processes. This methodology allows for flexibility in the development process since it aims to provide a boost of creativity for developing innovative products and systems. For this reason it is currently less well adapted to understanding evolutionary systems like a transportation system but it can still be useful by giving a different perspective of how the system fundamentally operates and which areas can be improved.

In order to start the SA process, the system needs to be seen in its context. A stripped down view of a Freight Transportation System (FTS) is shown in Figure 6-17.

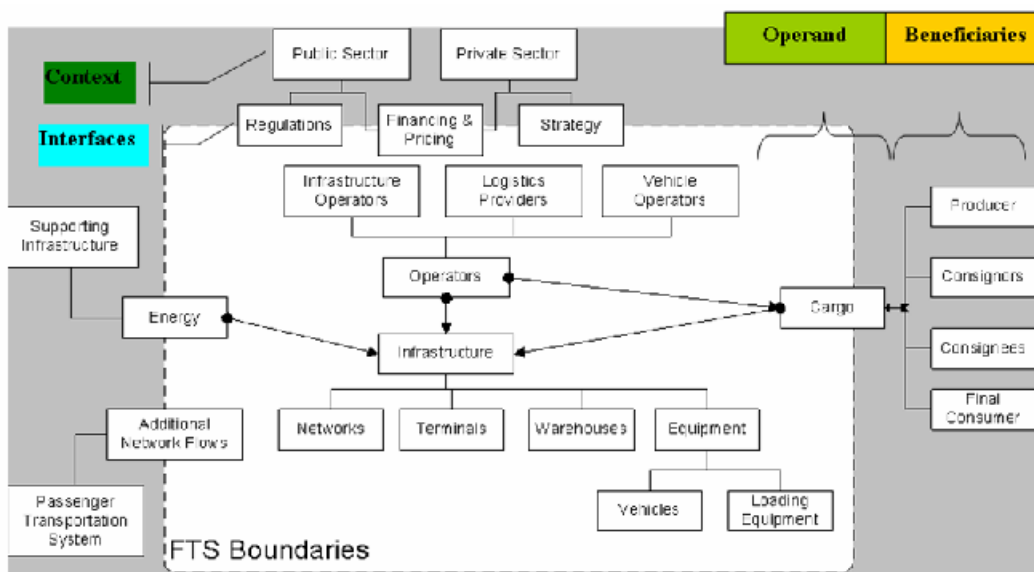

Figure 6-17 Schematic View of a Freight Transportation System (FTS) from an SA perspective

The main elements of FTS in the above representation are the infrastructure and the agents that operate it (from organizations to human drivers). The infrastructure element is constituted by the networks, terminals, storage facilities (denoted as warehouses) and the equipment (that includes network vehicles and terminal equipment).

FTS Context and Overview

The operand of this representation is the freight that is being transported, or transformed from its initial position to one in which it has added value. The beneficiaries of this transformation process are the consignors (shippers) and consignees (receivers) which could also be represented as producers and consumers.

The FTS system is incorporated within the greater context of society, which includes organizations (as operators, beneficiaries, and managers), other supporting infrastructures (e.g. the power grid, the fuel extraction and refining industry, the equipment manufacturing plants), as well as systems that use the same infrastructures but for different purposes (e.g. the passenger transportation system, and the defense system).

FTS
Decomposition

From a functional perspective as well from a structural perspective, an FTS system can be studied in three distinct levels (see Figure 6-18): the **micro** level that encompasses the actions of receiving, transporting and delivering goods; the **mid** level that includes the transporting organization; and the **macro** level that involves the processes for planning, constructing, maintaining and operating the infrastructure that is necessary for the micro-level functions to take place. The mid and macro levels are functioning in a way that satisfies the needs of both beneficiaries and accommodate the operand specifications (cargo). The levels also reflect differences in timeframes with expanding time horizons as one goes from micro- (hours to weeks), to mid- (days to months), to macro- (months to decades).

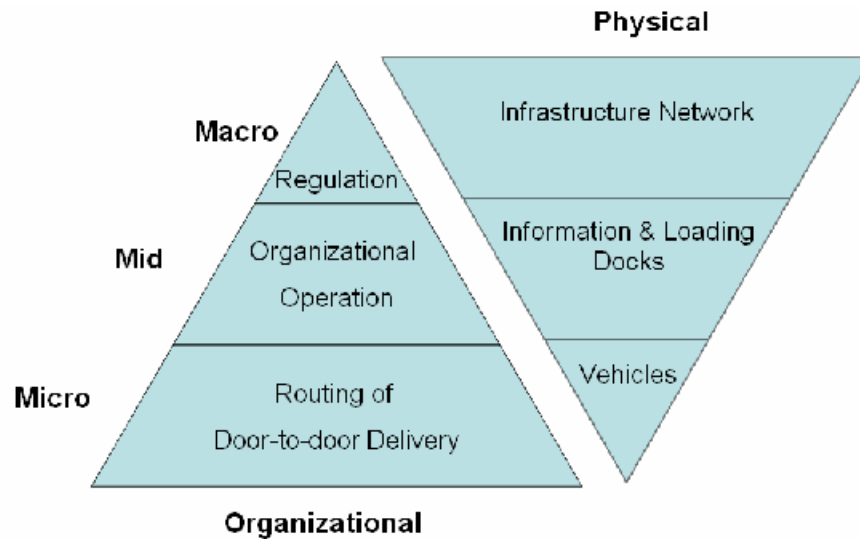

Figure 6-18 Organizational/Functional and Physical/Structural Decomposition of an FTS

FTS Problem
Statement and
Concept

After providing the system context, the SA process provides the problem statement and concept of the studied system. This is usually done in an unbiased way that avoids pre-conceived notions of traditional or common ways to address the problems (solution-neutral). Two possible constructs of problem statement and concept are shown in Figure 6-19 using the Object-Process-Methodology (OPM) developed by Dov Dori (63) as a “language” for representation.

OPM Notation: Ovals are processes and rectangles objects. Items with a shadow are physical while the rest are “informatical.”
 Links: *white triangle* indicates specialization, *triangle with embedded black triangle* indicates characterization, *line with white circle* indicates instrument for an action, while *a line with a black circle* indicates agency. Lines with arrows indicate relationships (consumption, affectation). A more detailed list of notation is available in (64).

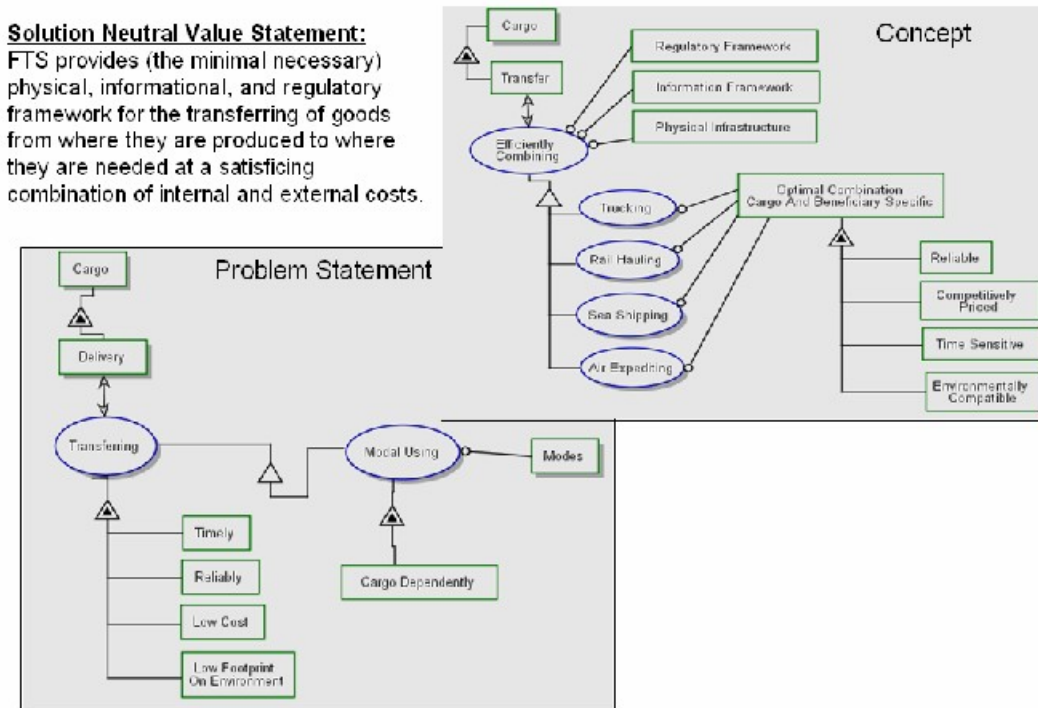

Figure 6-19 System Architecture Representation of Problem Statement and Concept of a Freight Transportation System (FTS) Using OPM.

A functional decomposition of the three levels is presented in Figure 6-20, Figure 6-21, and Figure 6-22. Some of the functions in the three levels were expanded to reveal more detail depth. Figure 6-23 and Figure 6-24 show the structural decomposition for the institutional sphere and physical infrastructure respectively. The latter also expands the structure of objects in order to show a possible structure.

Although the vantage point of the SA approach can be seen from these figures, their real advantages and insights would be generated if compared to existing situations. In our example, having a “solution-neutral” approach might lead the planners to consider sea-shipping in addition to or as a replacement of the land-based modes.

The current planning system is based on aggregate transportation needs satisfaction; the planning level (macro) is primarily disconnected from the user level (mid and micro) as shown by the expanded “Regulating” function of Figure 6-22 where the functions connecting the private sector and the function is lobbying, courts, and privately sponsored research. Changing that connectivity and having the planning to take into account, anticipate, react to, or even precipitate changes in the SCM processes of the firms in the region is not part of the current transportation planning state-of-the-art.⁴⁷

⁴⁷ Ultimately this proposition would lead to Real-time User Requirement Informed Transportation Planning.

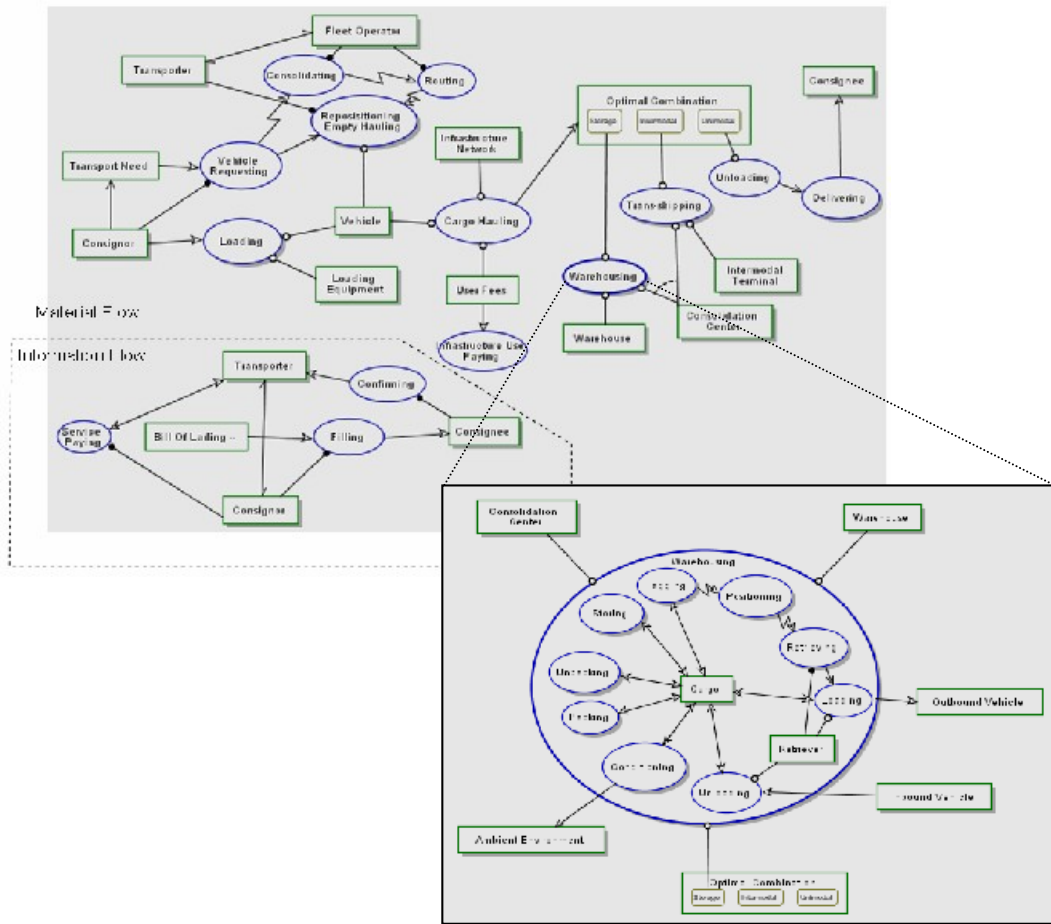

Figure 6-20 Micro-level Functional Decomposition of an FTS: Door-to-Door Delivery

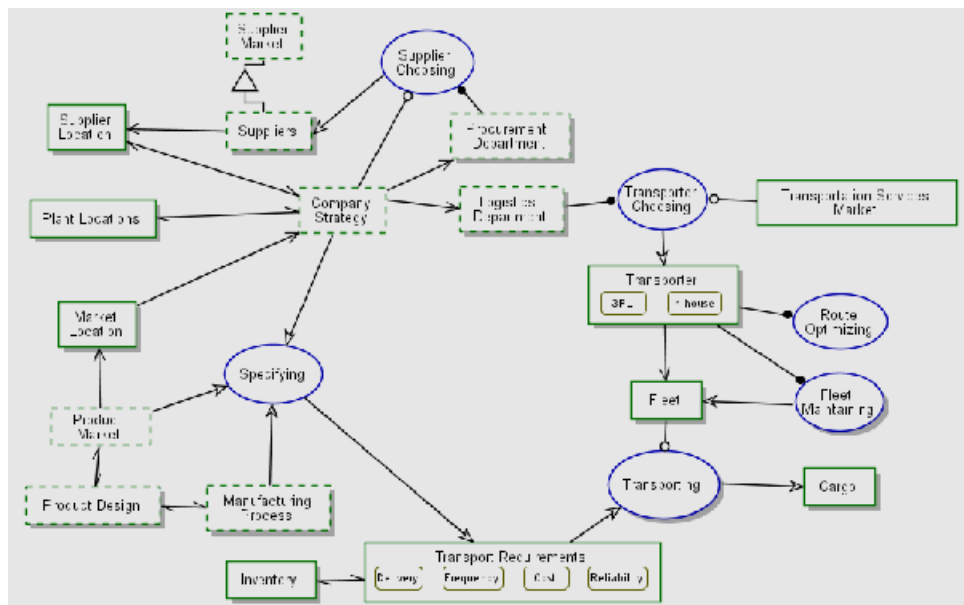

Figure 6-21 Mid-level Functional Decomposition of an FTS: Supply Chain Strategy

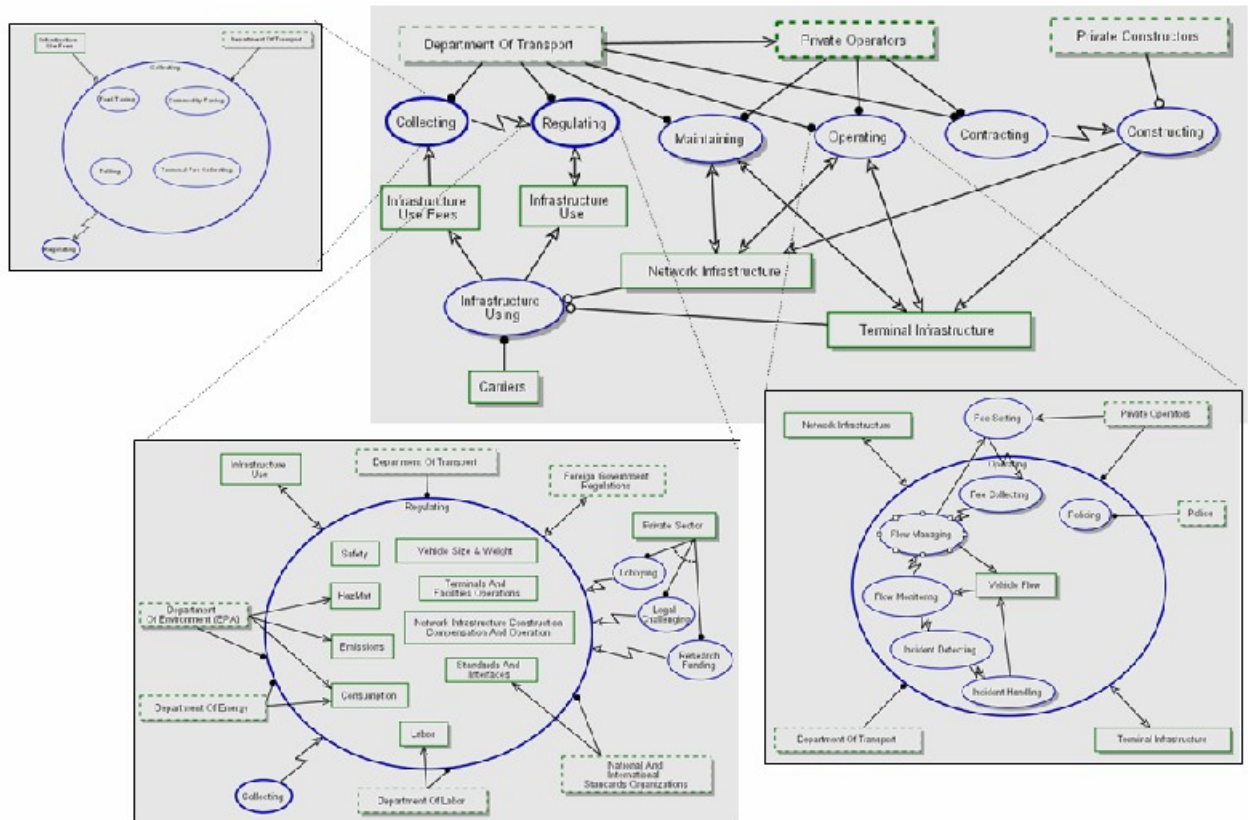

Figure 6-22 Macro-level Functional Decomposition of an FTS: Regulations and Infrastructure Building

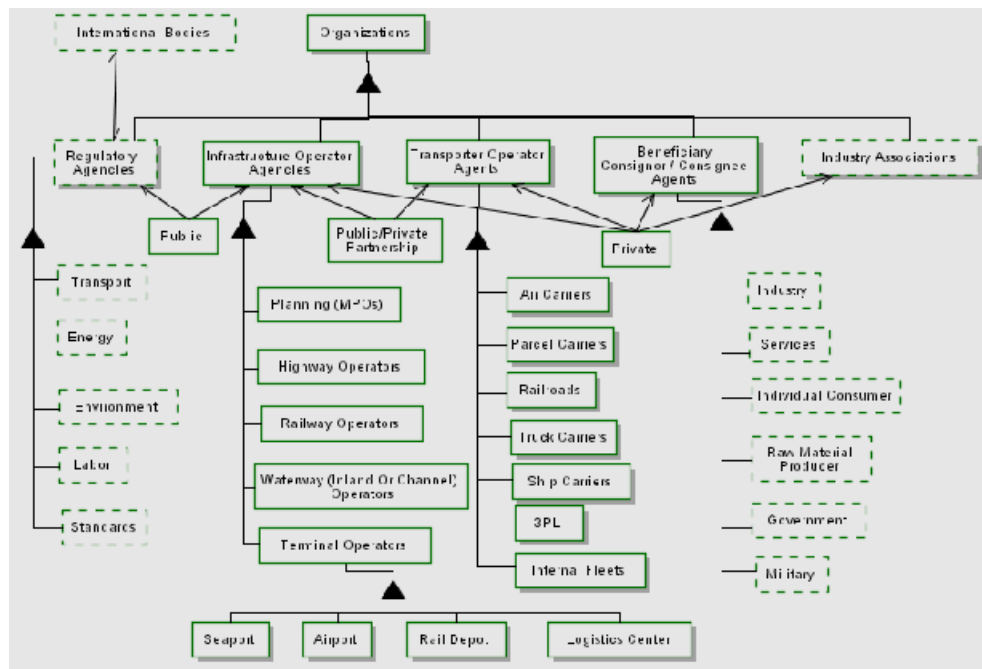

Figure 6-23 Structural Decomposition of the Institutional Sphere

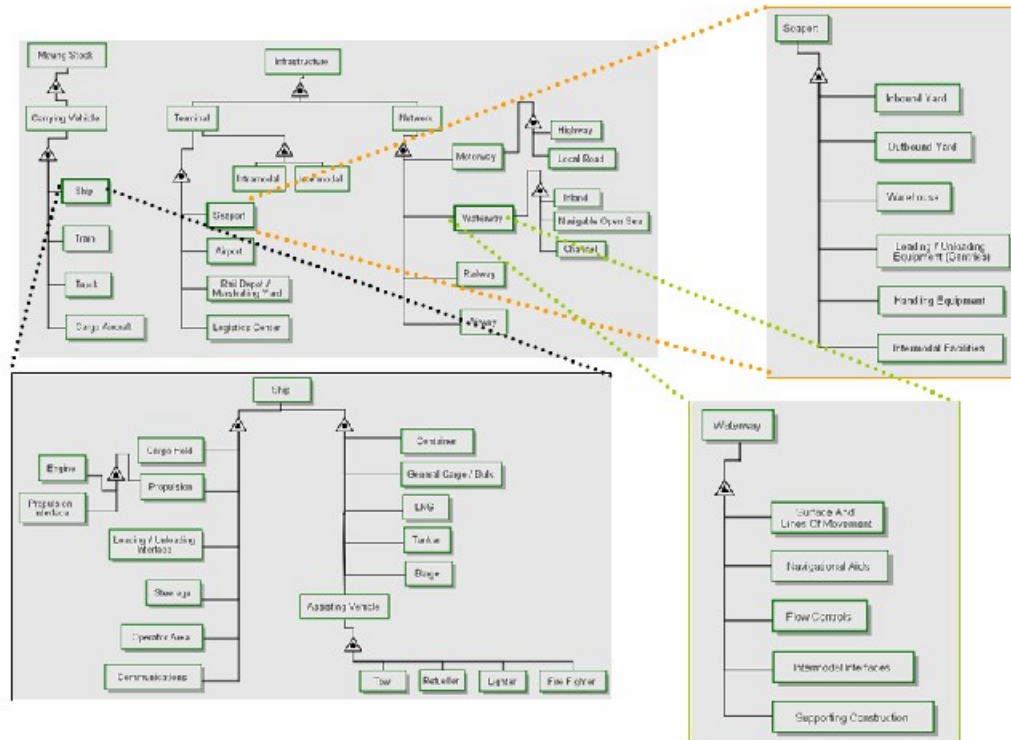

Figure 6-24 Structural Decomposition of the Physical Infrastructure

Insights gained by using System Architecture (SA) Analysis:

Disaggregating the levels of function and form.

Identifying previously not-considered solutions or weaknesses in implementation of functions.

Visualizing changes for newly proposed connection of objects and functions; e.g. from the traditional separation of planning and individual activity (aggregate transportation response) to direct linkages of transportation planning and SCM activities.

6.2.1.4.4 Comparative Summary of “Insight” Methods

For a clearer view of all three methods that we proposed for analyzing the RSTP/SCM system we conclude the presentation with a tabularized summary (Table 6-7) of their characteristics, advantages, disadvantages and usefulness.

Comparative
Overview of
Methods

Table 6-7 Comparative Summary of proposed CLIOS methods of analysis: CLIOS Diagrams, Link Matrix, System Dynamics, and System Architecture

	Characteristics	Advantages	Disadvantages	Insights
CLIOS Diagrams	Visual diagrammatic representation of static interactions of the system components	Intuitive, easy visualization, Good tool for engaging input of experts and presenting to laypersons	Visually cluttered even for moderately complex systems Difficult to extract quantitative information from ⁴⁸	Direct view of important connections Forces thinking about the system Balances abstraction with reality
Link Matrix	The matrix’s cells represent interaction among components	Concise, Denser information, Allows for quantitative manipulation of data	Less intuitive than diagrams Link trees are harder to read Static	Clustering clarifies interdependency of components Ranking indicates potential high leverage components
System Dynamics	Interactions of components of a system are modeled as loops that reinforce or reduce an influence	Allows for both quantitative and qualitative modeling Good intuition and communication Existing modeling platforms	Harder to validate, Quantitative modeling could create false sense of reliability Hard to choose values to quantify non-measurable variables	Dynamic understanding. Focus on functions. Quantification and experimentation with models.
System Architecture	Breaks down studied system into objects and functions	Visualizes goals and objectives Advocates solution-neutral thinking	Static Can be cluttered Architecture of evolutionary systems looks efficient	Disaggregation of function and form. Opens-up solution space.

⁴⁸ Ideally CLIOS software would allow the user to draw the diagrams and provide information for each component and link. Then the system would automatically generate the link matrix and suggest clustering solutions. Possibly dynamic simulations could be facilitated as well.

6.2.2 Design, Evaluation & Selection Phase of the CLIOS Analysis for Region A

In order to transition from a representation of the system to a design that improves it, it is necessary to define the parameters of the system that can be used to measure performance and thus improvement. Step 6 in the CLIOS process that follows provides exactly that.

6.2.2.1 Step 6: Identify Performance Measures and Refine System Goals

Needs - Metrics Matrix This step in effect translates the system objectives that were identified in Step 1 into measurable⁴⁹ quantities or parameters. An initial set of measurable information that can be collected from the system of Region A is shown in Table 6-8. In order to categorize and utilize those metrics another tool from product design comes handy: the *needs-metrics matrix* as discussed by Ulrich and Eppinger (12). This matrix simply matches the needs or requirements or objectives of the system with quantities that can be measured or at least compared among various states.

Table 6-8 Indicative Measurable Information for System Description

Area	Desired Information
Regional Infrastructure	Map of designated truck routes in the region. Capacity of network Average travel time and variance Congestion-prone areas Accident-prone areas Planned Infrastructure expansions Position of intermodal terminals
Flows	Measured and modeled cargo flows OD nodes location and throughput Intermodal terminals location and throughput Breakdown of flow based on commodity and priority! Breakdown of flow relative to the region (interregional, intraregional, through) Proportion of trucks in general traffic flow Data on 3PL and private fleets (number of trucks, itineraries, cargo, shifts etc)* Maintenance cycles
Land Use	GIS Maps with information on land uses and zoning Location of infrastructure and terminals
Safety / Security	Accident rates related to freight Hazmat routes and types Potentially affected areas Truck inspections results (random and checkpoint)
Environment	Air emissions from idling and moving vehicles (trucks, planes, locomotives, ships) Complaints filed by residents Emissions from freight-generating facilities Environmentally sensitive areas in the region

⁴⁹ Measurable does not necessarily imply only objectively quantifiable parameters. Subjective and/or qualitative comparisons among states may also qualify as measurable parameters. Equal emphasis should be given to quantitative and qualitative metrics in order to avoid the bias of presenting and discussing only those aspects quantified and thus provide a sense of subjectivity.

From the general needs-metrics matrix of Table 6-9, a smaller set of metrics might need to be picked as representative of the system functions in order to provide a more tangible yet adequate way of measuring and discussing the system improvements. One criterion for weeding out the metrics is the ease or potential for the parameter that they measure to be influenced by system changes. Another criterion can be if they are duplicate, that is if a system parameter can be measured adequately using more than one metric then not all need to be included. In that case, the one which is the more easily quantifiable or the one that has sources of data available may be preferred. Finally, metrics that measure more than one parameters should be preferred as well.

Deciding on
Needs

The second part of Step 6 involves refining of the goals set in Step 1 into more specific objectives (based on the definition of Section 3.1). In order to make the objective tangible it is useful to tie them with the metrics and assign target values to be achieved. These values will be compared with estimates of the current conditions to track progress towards the objectives and will inform Step 7 (Identification of Strategic Alternatives) by dictating the extent of the policy interventions that are needed (an easily achieved objective usually requires less radical policies). Specific objective examples are context-specific and they could take the following formulation: "Reduce congestion by 20%," "Increase capacity of corridor X by 1000 veh/hour," "Reduce emissions from trucks by 15% in 3 years while catering to 20% increased demand."

Assigning
Values

Finally, one of the most important elements that should be taken into account when evaluating sustainable policies is the issue of timing. In sustainable development the breaking down of the effects of policies further into the future and across generations is important and appropriate discounting factors (positive, zero or negative) should be used to take into account the effect of ongoing negative externalities for future generations.

Evaluation
Timing

Table 6-9 Needs – Metrics Matrix for Model A

Needs	Private Sector	Public Sector	Profits and Share Value	Percent of Market Share *	Survey Answers	Return Ratio	Service and Maintenance	Frequency	Percent of on-time delivery	\$/ ton-mile	\$/ Item / day	Items / Labor-hour	Turnover ratio	Lead Time	Emissions or effluent / item produced	Emissions / item transported	Wages as % of regional average	% of recyclable components	% Growth rate in GRP	% of unemployment	Import / Export Ratio	% of processed over raw material exported	STD of travel time	Total Emissions and Effluence	Average usage over infrastructure capacity	% of price over total cost (construction, Accidents / ton_mile
1 Shareholder Value	X		X																							
1.1 Competitive Position			X																							
1.1.1 Customer satisfaction			X		X																					
1.1.1.1 Product Quality			X		X																					
1.1.1.2 Right Price			X																							
1.1.1.3 On-time Delivery								X																		
1.2 Profit Maximization																										
1.2.1 Cost Constraining																										
1.2.1.1 Transport Costs								X																		
1.2.1.2 Inventory Holding Costs								X																		
1.2.1.3 Labor Costs								X																		
1.3 Efficiency																										
1.3.1 Productivity												X														
1.3.1.1 Inventory levels												X														
1.3.2 Flexibility												X														
1.4 Regulatory compliance **																										
1.4.1 Environmental																										
1.4.1.1 Production Emissions															X											
1.4.1.2 Fleet Emissions															X											
1.4.1.3 Waste																X										
1.4.1.4 Reusability / Recyclability																	X									
1.4.2 Labor																										
1.4.3 Trade																										
1 Maximizing External Benefits			X																							
1.1 Economic Growth																										
1.2 Employment																										
1.3 Regional Development			X																							
2 Minimizing External Costs																										
2.1 Congestion									X																	
2.2 Environmental																										
2.3 Social																										
2.4 Safety																										
3 Financing																										
3.1 Infrastructure Utilization																										
3.2 Infrastructure Pricing																										

** Note on market share: The market niche classification is important. Ford and Ferrari, for example, do not share the same market niche although they both sell cars. The same is true for individual products. (or exceedance if part of the competitive strategy)

6.2.2.2 Step 7: Identify and Design Strategic Alternatives for System Performance

In order to design policies that will satisfy the goals and objectives of Steps 1 and 2 it is necessary to list the potential policies that are available to planners of both the public and the private sector in terms of affecting change to the freight transportation system on a regional scale. Two possible lists for the private and public sector respectively are shown in Table 6-10 and Table 6-11.

Table 6-10 Freight Transport Options for the Private Sector

Product Design	
	Mass customization Design for SC Design for Production Design for recyclability / reusability Quality
Supply Chain	
Strategic	Supplier choice Production outsourcing Import inputs Export outputs
Methods	JIT Cross-docking B2B / B2C EDI use Fleet management
Location	Warehouse location Retailer Location Factory Location
Procurement	Bidding Portfolio supply
Organizational	
	SC Vertical integration Service Outsourcing (3PL, transport, etc) Integration/coordination of departments Enterprise design
Research	(Emphasis on applied)

Table 6-11 Freight Transport Related Options for the Public Sector

Infrastructure	
Location	Highway Railroad Airport Seaport
Capacity (Clearance, weight, traffic flow)	Road Bridges Intermodal Connectors Tunnels
Operations	Traffic signal timing Maintenance Incident Clearance
ITS	Electronic Toll Collection (ETC) Advanced Traffic Management Systems (ATMS) Ramp Metering
Facilities	Intermodal Facility Logistics Park Truck Service Stations
Incremental Changes	Truck-only lanes Layover Facilities Hours of Operation for Facilities Grade-separated crossings Adequate turning radii
ICT	Internet Communication Network
Regulation	
ICT	Band allocation (RFID, Communications) Standards (EDI, Communications, RFID)
Environmental	Externality pricing Vehicle Emissions Vehicle Design Production emissions
Safety	Truck Hours of Service (HOS) Crew requirements for vessels Truck Weight and Size Regulations
Infrastructure	Infrastructure Pricing Fuel Tax
Trade	Rate and market Regulations Import/Export taxes and duties
Land use and Zoning	Free trade zones Industrial / residential land allocation
Institutional	
	Integration/coordination of departments Regional Planning
Policy	
Research	(emphasis on fundamental)
Subsidies	Indirect modal subsidies Direct Subsidies
Strategic	National "champion" industries Education

What is striking in both lists is that implementing any set of policy options requires coordination and cooperation among departments in a private firm or across the government. Budgetary restrictions and perhaps political considerations may render some of the policy options listed above infeasible, ineffective or undesirable. For this reason, along with identifying the policy alternatives, it is useful to have a sense of direct monetary cost and benefits for implementation, indirect costs and benefits, environmental impacts and political implications.

The Systems Dynamics (simulation) model developed in Step 5 may provide a platform to assess on a preliminary level policy effectiveness and emergence of unanticipated second order behaviors. This way the model can be used for evaluation of the options and supplement the Step 9 selection process.

This activity will eventually create “bundles” of options (strategic alternatives) that will be coherent combinations of individual policy options and are relevant to the region’s needs. Individual policies may be duplicated across bundles but in principle the policy bundles should represent different perspectives of how the system should be changed if at all. It would be preferable if this disaggregation is not based on ideologically opposing views (for example on progressiveness vs. conservative status-quo retention, or in environmental focus vs. business focus) since this creates a research environment prone to biased judgment. We discuss policy alternative bundles further in Section 7.3 when discussing the applicability of our proposed framework on the real world.

6.2.2.3 Step 8: Flag Important Areas of Uncertainty

Uncertainty as discussed in de Neufville et al. (67) is not necessarily a liability but can also be viewed as an opportunity. In the context of freight transportation, the areas of uncertainty range across a large spectrum. For example, the regional economy can affect actual demand of products, fuel costs can be affected by external conditions, technological advances can bring new regional competitors and render regional comparative advantages obsolete, emergence of competitor suppliers may require the development of new corridors etc.

The trends that we are witnessing that affect the way business and people use freight transport become a significant source of uncertainty. The effects of trends like internet shopping, mass customization, carving new market niches, global outsourcing, 24-hour manufacturing operations, just-in-time manufacturing, security requirements are not yet clearly understood.

As a general rule, incorporating flexibility increases the overall present value of projects since it allows for exploitation of positive outcomes but also prevents severe losses from negative outcomes. Since models are indicative of reality they are not expected to predict the future but at the least they can be used to estimate the performance of the system.

6.2.2.4 Step 9: Evaluate Strategic Alternatives and Select Robust Ones that Perform “Best” Across Uncertainties

This step is the logical extension of the work that has been built up to now. In classic planning fashion, it uses the models (conceptual and analytic) built in Steps 3 to 5 to estimate system performance for the policy alternatives described in Step 7. To quantify the performance, the metrics defined in Step 6 are used and the results are compared to the objectives set in the second

part of Step 6. Since neither the system nor the models are usually deterministic the performance of the policy alternatives is estimated using different scenarios based on the identified uncertainties from Step 8.

In evaluating the alternatives, understanding the barriers to implementation (political, social, and economic) will be an important aspect of the planning process. In the real-world, transportation can be a very contentious politically sensitive subject. Even freight transport policy, which is less visible than passenger transport can be stalled by strong unions or industry associations.

In order to counterbalance the influence of reality-checking of barriers that may lead to more conservative planning, backcasting may be employed. Backcasting, as scenario planning in reverse, is a technique that is based on visualizing the end state without restrictions from the extrapolation of present trends. This idealized end state is then used for creating the policies that will lead to achieving this state or in other words it is an exercise on how a desirable future outcome can be attained.

Another balance that may be even harder to strike are the trade-offs that would be needed between needs. Especially pricing externalities or allocating resources previously considered practically infinite could clash with the private sector's goals of maximizing shareholder value (if value is mainly in monetary terms) and thus convincing the private sector partners may be a hard task. In any case there will be strategies that by a combination of measures would yield better outcomes than others and hopefully would fall into the win-win category.

6.3 Conclusions on the Proposed RSTP/SCM Process

Having completed the first two CLIOS stages for the Model A we have reached the limits of the usefulness of a conceptual generic model. The reason for this is that the Implementation stage is very context specific by definition and this makes futile the attempt to devise strategies for implementation of the policy options away from the real-world environment nuances.

With the RSTP/SCM framework structured as a CLIOS meta-process we show that it is feasible to create a transportation planning process that is informed by and intentionally affects the supply chains. We also show that the integration of transport, trade, and the environment is needed if sustainability becomes a central goal in transportation policy making. For example, by using the SD model we can appreciate that changing product consumption affects transport with more than one mechanisms or that imposing regulatory restrictions on the production process can have ambiguous outcomes depending on the ability of the sector to react to the change without altering throughput. This kind of events can cause ripple effects on the economy of the region which can lead into reinforcing feedback loops or balance out without leading to crises. To name another example, pricing freight transport externalities would increase in freight rates may increase end-price which in turn may lead competitors to enter the market and eventually lead to a price-war and economic downturn or actually balance out without leading to a crises.

Not having run any simulations and of course not having used the process in a real world situation to test its viability, a conclusive verdict on the viability of the scheme cannot be given in this document. It is rather a proposition to be further tested. The essential conclusion that can be drawn up to now is that such an implementation will be a complex process with impacts that can not be predicted with certainty. The high clockspeed changes of the global economy – especially when it comes to high-tech industries – make regional economic development difficult to predict

and as a consequence this uncertainty compounds the uncertainty faced for the returns on investment for transportation projects.

The complexity of the problem becomes even greater when the goals of sustainable development are added to simple economic development. In the former case the process we propose has, in principle, additional advantages since the environmental impacts and the tools to influence them are integrally considered in the process.

Until now, having a balance sheet of impacts for a given product from the manufacturing process to transportation and usage/operation (i.e. from the total life-cycle perspective) has not been considered as worthy of consideration for regulatory regimes. As we elaborate more in the next chapter, it may be possible to use transportation as a springboard to control and monitor the resource-intensiveness of the product life-cycles. These ideas are explored in Part 3 by bringing together Part 1 and Part 2 and discussing further the applicability of our proposed integrated transportation planning process.

Part 3

System Integration

If a serious attempt is to be made to achieve sustainable transport, then a group of nations has to take the lead and demonstrate the art of the 'impossible.'
Banister et al. (69)

7 Integration and Policy Recommendations

The projects that were described in Chapter 5 were all successful or partially successful implementations of a freight-oriented transportation policy. What they lacked is a consideration of at least one or more parameters that would create a consistent reference mode of how those projects would affect the supply chain and their environment (economic, social, and natural). Such parameters are the distribution of suppliers, the business development of the region in which they are situated and the adjacent ones, their ability to withstand crisis and economic downturns, or even their environmental impact not in the directly surrounding environment but as a regional (or even a national and global) system.

In Part 1 we argued that in the competitive regional environment of the 21st century a comprehensive consideration of those issues may provide firstly a competitive edge to the region and secondly create a basis for sustainable transportation. In Part 2 we proposed a framework based on the CLIOS process describing how SCM considerations can be integrated into RSTP planning with a sustainability agenda. We discussed what issues the planning process should take into account, and how it may affect the region. In Part 3 we discuss the shortcomings of current regional planning regarding how they can be addressed by our framework (Section 7.1); then in Section 7.2 we discuss the advantages and disadvantages of our framework and how it can be used across regions and propose the consideration of a variety of policy measures that focus on SCM and sustainability; in Section 7.3 we bring forward policy recommendations that relate sustainability and freight sector along with barriers that can be encountered when trying to implement a comprehensive RSTP/SCM planning process and finally we indicate directions for further research and conclude (Section 7.4).

7.1 Identified Shortcomings of Current Regional Freight Transportation Planning

As a general critique, we can say that most transportation planning for the projects that have been described in Chapter 5 has been made on the “*aggregation principle of transportation planning*,” that is planning based on extrapolation of current flows between origin – destination pairs. These extrapolations are usually conducted by regression models that cannot take into account individual characteristics of industries not to mention developments in technology or the global economy. In short this approach translates to an expectation that given capacity, users will find ways to utilize it. This approach has been pretty much the only approach up to now and of course it has proven its viability but we argue that when it comes to freight transportation there are advantages in understanding the nature of the shipments as well as the individual origins and destinations.

The
Aggregation
Principle

Of course, the counter argument is not necessarily to restrict capacity but to understand the costs, opportunities, benefits, and potential for flexibility that certain projects offer. In the current globalized environment a region cannot positively alter its competitive advantages by restricting transportation network capacity or by heavily regulating its imports. But it can rationalize those costs and benefits and align them with broader goals especially when among the goals of the plan is sustainability – with its environmental and societal parameters. With a model that registers the impact of transportation projects on the supply chain (and vice versa) further predictions can be made and along with preparations for changes in land-use and zoning rules across the region.

Kane and Del Mistro (71) in their overview of transportation planning indicate that the shortcomings of current transportation planning may reside in the mental model of the planners that adheres to a mechanistic, or “rational comprehensive,” perspective rather than a systemic/holistic view. The characteristics of the former model are quoted in Box 7-1.

Box 7-1 Characteristics of the “Rational Comprehensive” model of transportation planning as quoted by Kane and Del Mistro (71)

- (a) the notion that analysis and decision-making are separable activities performed by different actors;
- (b) the definition of “problems” that are abstracted from a complex world, and the implicit assumption that problems can be “solved”;
- (c) an orientation towards optimization, or searching for the best solution;
- (d) a commitment to reductionism; research and study of systems that are defined by a limited number of elements or variables; and by their interactions; reliance on data, models and combinations thereof, as modes of representation and inquiry;
- (e) quantification of information;
- (f) commitment to objectivity: the belief that the analyst or researcher is outside the system he or she is studying, and that knowledge can be found which is independent of the observer;
- (g) a commitment to problem-solving as a sequence of logical steps: for example, problem definition, specification of alternatives, enumeration of goals, assessment of consequences, selection of a course of action and implementation of a selected course of action.”

The framework that we propose in Part 2 provides an intermediate or hybrid approach that we think bridges over the rational comprehensive model of transportation and the holistic/systemic “soft” one that Kane and Del Mistro present. For example in our framework, decision-makers are engaged from Step 1 through goal identification (point a of Box 7-1); the process is not motivated by an abstract problem-solving mindset but instead by a recognition of the system as a whole (points b and d). On the other hand there is a stated preference to quantify information and parameters and attempts to optimize if possible or at least satisfy the goals set at the beginning of the process (points e and c). Finally, it is a structured process with sequential steps (point g) but the disadvantages of the sequence are mitigated by stressing the need for several iterations as a prerequisite to successful application.

But more importantly, our framework proposes the elevation of transportation planning to a tool for advancing sustainability goals. In the following section we discuss how this is done and what advantages are gained through an implementation of the framework, as well as its potential flaws.

7.2 How applicable is the Proposed Framework? Advantages, Disadvantages and Barriers in Application

Transportation planning during the 90’s and up to now is undergoing transformation that derives from the realization that transportation decisions are not only important but also are highly subjective and influenced by political factors. When it comes to sustainability considerations, freight transportation plays a very significant role. As we have seen in Part 1, it provides the critical link among suppliers/producers and markets.

Banister et al. (69) identify the following key issues regarding the success of sustainability-oriented transportation policies: (i) *packaging* – where the increase of linkages and synergies is

sought, (ii) *timing* – the time scale of implementation and results varies significantly across policies and their effectiveness can be mitigated through premature ending, (iii) *implementation* – which organizational actors can implement policies and what barriers they encounter, and (iv) *responsibilities* and *coordination* across the actors.

The advantages that we expect from our proposed planning process are:

Advantages

1. Systemic perception of the transport/production system;
2. Consideration and weighing of non-transport policies for sustainability of freight transport
3. Better predictive modeling and realistic scenario planning of land use and traffic flows based on actual production trends as compared to regression models,
4. Clearer understanding of the effect of transport projects on the whole economic, social, and natural environment of a region,
5. Stakeholder participation from the beginning of the process,
6. Several iterations and incorporation of flexibility in projects rather than static proposals,
7. Promoting out-of-the-box thinking for use of non-transport related solutions,
8. Promotion of proactive rather than reactive planning.

Of course these advantages remain on a theoretical basis until being proven on actual applications. There is also the possibility that some of the perceived advantages can be disadvantages in different planning settings. This is true especially in the case of advantages 2 and 6:

Disadvantages

- (i) For the former, the consideration of non-transport policies from traditional transport planners requires a high degree of integration among government agencies. If this requirement is not met, internal friction over agency jurisdictions may escalate and prevent positive progress.
- (ii) Similarly for the latter, incorporating flexibility in projects and allowing for subsequent iterations in planning has as a prerequisite a high level of trust among the stakeholders. If this does not exist, the perceived uncertainty may prohibit the private sector from locking-in projects through investments and also may make large projects that are open to public scrutiny harder to realize and complete.

The major disadvantages of the process are probably more pronounced in the implementation since it challenges a lot of the accepted truths in planning and policy. On the other hand there are recent positive changes that open the possibility for realizing radical changes. Firstly the realization that systemic thinking is needed is gradually being accepted at the higher echelons of government administration (see for example the speech given by Emil Frankel as Assistant Secretary of Transportation Policy at the U.S. DOT during the TRB conference (65)). Secondly, as government resources are less abundant the motivation to consider public/private partnerships, to tie project performance with ROI, and to consider alternative planning proposals will become mainstream. Thirdly, as public/private partnerships become more common the issue of disclosure of sensitive information from the private sector shippers may become easier to resolve as trust grows, possibly accompanied by legal agreements.

The above optimistic changes notwithstanding, the greater controversy over implementation of the proposed process may be raised on ideological grounds. It is possible to classify planning approaches under two broad categories or schools of thought in capitalistic market societies:

Political
Conditions

- (i) The “laissez-faire” model where the intervention of the government has the smallest possible footprint and where market interactions are expected to self-regulate, and
- (ii) The “interventionist” model where the government is expected to intervene and regulate whenever public goals clash with free market actions.

In the real world governments are positioned somewhere in the gray area between the two ‘extremes.’

Implicit in the two approaches is an ideology/political statement regarding sustainability. The first approach attributes the highest priority to economic growth and therefore if there are concerns about the other two parts of sustainability (i.e. environment and social equity) there is the expectation that any problems will be solved over time as they come up. Closer to the second side of the spectrum, i.e. the “interventionist” approach, all around sustainability can take a more prominent position as a policy goal. It seems that our proposed process can provide more advantages to regional governments that lean towards the “interventionist” model since in this case trying to satisfice across more than one parameter requires a systemic/holistic approach.

Global vs.
regional
effectiveness

On the political front, even the notion of broader sustainability goals encounters effectiveness problems at a national level. For example, if goals like the reduction of greenhouse gases emissions are to have effect on a global scale then the scale of the region should extend across national borders. Cooperation on this scale requires significant effort and success is difficult to achieve as shown by the Montreal Protocol that regulated CFCs and the Kyoto Protocol that attempts to regulate greenhouse gases (GHG).

Complexity
vs. insights

Another argument that can be raised against this approach is that of the complexity of the modeling part of the process itself (as described in Section 6.2.1.4 that describes Step 5, i.e. seeking insight for the system). The representation of the supplier system is hard even for one company and one product. For a large region an accurate representation of individual companies would be close to infeasible both for lack of computational ability as well as for lack of cooperation from the actors themselves in their disclosure of proprietary or sensitive information.⁵⁰ But the modeling of the region is not done for having an exact knowledge of the flows through the system; this is best performed with transportation simulation models based on TRANSCAD, MITSIM and similar platforms. Instead the reason for simulating the supply chain is for creating a model that facilitates deeper understanding of how and to what extent transport and business interacts, and more importantly to have a platform for experimentation for different types of transport and non-transport related policies that nonetheless affect the supply chain as well as the environment. In the next section we present different set of policies that can be explored through the models.

7.3 Proposed Policies and Applications (Policy Recommendations) for review

This section expands on the first part of Step 7 (identification and design of strategic alternatives) of our proposed process. We present ‘bundles’ of alternative policies based on existing literature as well as some ideas not presented before (at least in this form). Those policy bundles are not meant as panaceas or as preemptive of other innovative context specific solutions that can come from applying the process. They are intended to provide a basis for discussion of their potential applicability and effectiveness regarding the attainment of sustainable freight transport.

With regard to the latter, one of the theses of this work is that the freight transportation impact on the environment is tightly connected to non-transport parameters of the production and use

⁵⁰ The latter effect has been noted in the disclosure of flow data from counties where large companies operate in the Commodity Flows Surveys conducted by FHWA as well as in the disaggregation of data offered by private sources like the Reebie Associates TRANSEARCH database.

process: from raw material use to end-of-life disposal. Given this, three main sets of macro-level policies have been proposed to address the combined impact of transport and production (i) *regionalization*, that is the intention of promoting more localized production and consumption, (ii) *dematerialization*, that is the development of smaller less resource intensive and more durable products and (iii) *spatial clustering*, which involves land use planning in order to consolidate related industries and reduce the amount of transport needed for parts. Banister et al. (69) suggest several policy packages for sustainable transportation. Those that are directly relevant to freight transport are summarized below in Table 7-1.

Regionalization
and
Dematerialization

Table 7-1 “Policy Packages” Proposed by Banister et. al as classified by OECD

(1) Fair and Efficient Distribution of Mobility – Tradable Mobility Credits. Transportation and the costs for it are increasing thereby creating social and geographical distribution problems. This policy package offers a flexible market based approach by combining market incentives and information technology, so that social and spatial equity concerns can be addressed.
(2) Promoting Subsidiarity in Freight Flows. Policies for decoupling freight transport from economic growth cannot only come from traditional transport policy. Structural changes are required to reduce the travel distance of goods through regulatory and fiscal incentives, and through comprehensive and stable industry directives – mainly set at the national level. These may include incentives for altering raw material inputs and increasing product re-use and recyclability.
(3) Promoting dematerialization of the economy. A main strategy for reducing the need for freight transport could be to reduce the material flows required for certain economic output. This also requires approaches that go far beyond traditional transport policy and would include incentives to business and industry to produce locally and reorganize distribution networks.
(4) Resource-efficient Freight Transport. This policy package aims to increase the resource efficiency of freight transport, reducing haul distance, and having more energy efficient vehicles. Again the incentives would be mainly regulatory and gradually introduced over time, but these would be supported by fiscal incentives (e.g. to increase load factors) and make better use of multimodal options.

Bannister et al. admit that the spatial structure of production and consumption patterns are influenced by a large number of factors and are not well understood (pg. 97). This makes the above proposed policies quite vague and as discussed in Section 6.2 quite hard to implement in the real world. As noted in the comments for each ‘bundle’, the scope of two out of the four ‘bundles’ reaches beyond traditional transport policy -- a finding that aligns well with the propositions and findings of this thesis.

One policy that may be worth considering spans the policy packages 1 through 4 as a possible means for striking the coveted balance between transportation, production and environment. This is a proposition of discriminatory pricing for freight based on the type of the cargo carried. Such a system can take the form of a combination of taxes and rebates (also known as ‘feebates’). As explained below it relies on an effective rating system for sustainability of the cargo, technologies to enforce it and of course stakeholder acceptance.

7.3.1 Sustainability Adjusted Freight/Environment Rates (SAFER)

The research described in Chapter 6 suggests that comprehensive life-cycle accounting of product performance is recommended for a comprehensive sustainability policy. This means that transportation fees should take into account not only the cost of transport part but also the cargoes’ performance during manufacturing, use, and end-of-life recyclability. In this section we further explore this idea.

Freight Discriminatory Pricing

The EU has already planned to enforce a GPS based transportation pricing scheme that accounts for road-use for trucks and sets additional fees for environmentally sensitive routes.⁵¹ Extending this approach one step further we propose the idea of using discriminatory pricing based on the environmental impact of content; that is the products that have been more harmful to produce are penalized over those that were produced sustainably as are those that are being returned for recycling. Ideally this scheme could rationalize both production and transport of goods to avoid the “recycling paradox”⁵² but more importantly it would allow for major transport incentives to be offered to products that utilize the “product-as-nutrient” approach of McDonough and Braungart (24).

There is a long history of setting transport fees for freight based on origin and content as exhibited by Odyzko (68). This historical tradition of discriminatory pricing has been all but abandoned in the interest of equality and because of the difficulty of keeping track of the contents of the shipments. Modern technology and a new understanding of equality that encompasses the environment can make sustainability-adjusted rates a reality. The idea is to create a common accounting system for the implications of any product using a scale of sustainability performance.

In order for such a policy to be implementable there is a need to create a rating system which for the purpose of this thesis we call Product Sustainability Rating Scale (PSRS). In an era where the Kyoto Protocol treaty has been ratified and operating in a significant portion of the developed world such a scale would facilitate other purposes as well. For example, in order to comply with the requirements for emission reductions, countries could ‘carbon-tax’ products based on emissions as classified by the PSRS. The PSRS would allow for assigning the exact carbon-emission “cost” of any given product stored among the information on its RFID tag.

Their far-reaching nature aside, there is a possibility that those policy packages may still be inconsistent with regard to achieving sustainability goals. For this reason further research based on this thesis’ arguments should substantiate their viability through dynamic modeling. The last section discusses those avenues for further research and reiterates the positions of this thesis.

7.4 Overview, Further Research and Concluding Comments

This thesis proposed the idea of infusing into Regional Strategic Transportation Planning insights and information from the private sector’s Supply Chain Management and treating these processes in an integrated fashion. This integration is facilitated by closer cooperation of the public and private sector and can take the form of an iterative process in which both actors adjust their respective inputs to the process gradually converging on mutually acceptable and optimized (or better satisfied) policy ‘solutions.’

Overview

We propose a comprehensive process to guide RSTP/SCM integration based on the CLIOS process as developed by Dodder, Sussman, and McConnell (8) and expanding on the meta-process for applying CLIOS on RSTP as developed by Sussman, Sgouridis, and Ward (30) (see also Chapter 5).

⁵¹ The relevant legislature is Directive 1999/62/EC on the charging of heavy goods vehicles for the use of certain infrastructures (COM(2003)448 final). A discussion of proposed amendments can be found in Kageson (70). In late 2004 Germany has successfully implemented a country-wide GPS-based truck toll which may be the basis for an EU-wide charging system.

⁵² It is conceivable that reclaiming some products for recycling may be more harmful than simply disposing of them.

This RSTP/SCM process interweaves the where, how, and who of both planning areas with macro-economic and environmental parameters. In a real world context though, only the bigger private sector supply chains would probably be considered on an individual basis and there would still be barriers in disclosing sensitive information about their suppliers as well as their plans. Lower quality of data regarding hard to measure parameters is also expected. These handicaps do not necessarily detract value from the process since the ultimate goal is to understand and plan for the evolution of a very complex system. Having even a crude model of how all these parameters interact with each other will help the planners in devising policy bundles that are adapted to the needs of their regions and their respective political mandates.

Actually proving that our proposed process is better than existing processes in achieving sustainability goals is something that can only be verified through a controlled real-world comparative application (perhaps in a way similar to Mostashari and Sussman (36) manner of verifying the merits of the stakeholder-assisted modeling).

Such verification is one possible outlet for further research on the RSTP/SCM process. Of course prior to real-world testing, several steps need to be taken. For example, a quantitative system dynamics model of the generic region (based on the conceptual model presented in Section 6.2.1.4.2) can be used for initial testing of the policy bundles we presented in Section 7.3. As a second step, the model can be expanded to incorporate more than one ‘foreign’ region with different characteristics and import/export patterns. This way, shifting of suppliers and regional competitiveness can be investigated. Another expansion can be the incorporation of more than one industry; this way the dynamics of several industries that are competitive, complementary, or independent can be investigated. This way, the effects of the proposed alternative policies can be tested on companies with different supply chain needs. Of course the variety of combinations can quickly become overwhelming but complexity of this level is still manageable with existing system dynamics software.

Further
Research

Finally, two additional lines of research can be opened: (i) by further examining the practicality of using the Link Matrix Analysis (as described in Section 6.2.1.4.1) on real-world applications and (ii) by using the System Architecture framework (as presented in Section 6.2.1.4.3)

This thesis showed that understanding the supply chains of the industries that operate in a region is important and that the needs of freight shippers and carriers beyond simple capacity enhancements should be considered. This is especially so when sustainability is among the policy goals of the transportation planner and of the public sector. In this case greater levels of cooperation and understanding of complex interactions are needed if the policy goal is to be achieved. Implementing such a process can be hindered by all sorts of barriers especially considering that up to now societies based on the consumption/production capitalistic market model have been relying on non-renewable resources for their development following a possibly non-sustainable path to growth.⁵³ The latter should not be a cause of despair but instead a challenge for “a group of nations to take the lead and demonstrate the art of the impossible,” as Banister et al. (69) urge.

⁵³ For an extended discussion of sustainability of western societies see Chapter 3 in R.P. Hall’s upcoming MIT doctoral dissertation and also (72).

References

- (1) Dernbach, J. C. (1998) 'Sustainable Development as a Framework for National Governance', *Case Western Reserve Law Review*, Volume 49, Number 1, Fall 1998.
- (2) Sussman, J. and C. Conklin. (2000). "Regional Strategies For The Sustainable Intermodal Transportation Enterprise (ReS/SITE): Five Years of Research." In *Transportation Research Record: Journal of the Transportation Research Board* TRB Record, TRB Paper Number: 01-0302.
- (3) Runhaar, H. (2002). "Freight Transport: at any price?" Doctoral dissertation. Delft University. DUP Science. Netherlands.
- (4) Moses, J. (2004). "Foundational Issues in Engineering Systems: a Framing Paper." Presented at the MIT Engineering Systems Symposium, 29-31 March, at MIT, Cambridge, Mass. 2004. Available at: <http://esd.mit.edu/symposium/monograph>. Accessed Jul. 2004.
- (5) Crawley E., O. de Weck, S. Eppinger, C. Magee, J. Moses, W. Seering, J. Schindall, D. Wallace, and D. Whitney. (2004). "The Influence of Architecture in Engineering Systems." Presented at the MIT Engineering Systems Symposium, 29-31 March, at MIT, Cambridge, Mass. Available at: <http://esd.mit.edu/symposium/monograph>. Accessed Jul. 2004.
- (6) Pendleton, T.A. (1998). *Regional Architectures: Definition and Integration into the Strategic Transportation Planning Process*. Unpublished thesis. MIT.
- (7) US DOT. (2001). *Regional ITS Architecture Guidance: Developing, Using, and Maintaining an ITS Architecture for your Region*. Oct.
- (8) Dodder, R, J. Sussman and J. McConnell. (2004). The Concept of the "CLIOS Process": Integrating the Study of Physical and Policy Systems Using Mexico City as an Example. Presented at the MIT Engineering Systems Symposium, 29-31 March, at MIT, Cambridge, Mass.
- (9) Harrison, J. and J. Sussman (2004). *Outline of a 12-Step CLIOS Process for Understanding Complex Socio-Technical Systems*. Working project unpublished. MIT.
- (10) Levinson D. and L. Zhang. (2004). "A Model of the Rise and Fall of Transportation Networks." Presented at the 2004 ESD Symposium. Available at: <http://esd.mit.edu/symposium/pdfs/papers/levinson-b.pdf>. Accessed Jul. 2004.
- (11) Maier, M. and E. Rechtin. (2000). *The Art of Systems Architecting*. CRC Press, Boca Raton, Florida. 2nd Edition.
- (12) Ulrich, T. K., and S. D. Eppinger. (2000). *Product Design and Development*. Mc-Graw-Hill Companies Inc. Second Edition.
- (13) Simchi-Levi, D., P. Kaminsky, and E. Simchi-Levi. (2003). "Designing and Managing the Supply Chain: Concepts, Strategies and Case Studies." 2nd Edition. McGraw Hill.

- (14) Anderson, E. G. Jr, C.H. Fine, G.G. Parker, "Upstream volatility in the supply chain: The machine tool industry as a case Study." *Production and Operations Management*; Fall 2000; 9, 3; ABI/INFORM Global, pg. 239.
- (15) Kasardra, J. (2004). "Aerotropolis: airport driven commercial development." Presented at the Annual TRB Conference 2004.
- (16) Economic and Social Commission for Asia and the Pacific (ESCAP). (2001). "Review of Developments in Transport and Communications in the ESCAP Region 1996-2001," United Nations, New York, 2001.
- (17) Mangan, J. (2004). In class lecture for the course "1.265/ESD.265 International Logistics." MIT. January 2004.
- (18) Fishman, C. (2003). "The Wal-Mart You Don't Know." *FastCompany*, Issue 77, December 2003, pg 68. Available at: <http://www.fastcompany.com/magazine/77/walmart.html>. Accessed Jun. 2004.
- (19) Arntzen, B. (2004). "Creating Supply Chains for International Trade." Presentation for the 2004 MIT Course 1.265 on International Logistics.
- (20) Grossman, E. (2004). "High-tech Wasteland: It's the information age so why don't we know how to dispose of a laptop safely?" *Orion Magazine*. July-August 2004. Abridged version available at: <http://www.oriononline.org/pages/om/04-4om/Grossman.html>. Accessed Aug. 2004.
- (21) Byrnes, J. (2004). During Lecture in Course: 1.261J Case Studies in Logistics and Supply Chain Management. Spring 2004.
- (22) Energetics, Incorporated. (2001) "A Roadmap for Recycling End-of-Life Vehicles of the Future." Workshop sponsored by the Department of Energy. Available at: http://www.es.anl.gov/Process%20Engineering/Documentation/Selected_Publications/ELV%20Roadmap%20.PDF. Accessed Aug. 2004.
- (23) Wikipedia. (2004). Online Encyclopedia. Entry for Supply Chain Management. Available at: http://en.wikipedia.org/wiki/Supply_chain_management. Accessed Aug. 2004.
- (24) McDonough, W. and M. Braungart. (2002). *Cradle to Cradle: Remaking the Way We Make Things*. North Point Press. New York. 1st Edition.
- (25) Ogden K.W. (1992). *Urban Goods Movement*. Cambridge University Press.
- (26) Hall, R. and J. Sussman. (2004). "Sustainable Transportation – A Strategy for System Change." Under review for the *International Journal of Sustainable Development*.
- (27) Polenske, K. (2001). "Competitive Advantage of Regional Internal and External Supply Chains." In *Regional Science Perspectives in Economic Analysis*, Benjamin H. Stevens, edited by Michael L. Lahr and Ronald E. Miller, Amsterdam, The Netherlands: Elsevier Science, B.V., pp. 259-284.

- (28) Lakshmanan, T. R. and W. P. Anderson. (2002). "Transportation Infrastructure, Freight Services Sector and Economic Growth." A White Paper prepared for The U.S. Department of Transportation, Federal Highway Administration. Center for Transportation Studies. Boston University. Available at: <http://www.ncgia.ucsb.edu/stella/meetings/20020115/Lakshmanan.pdf>. Accessed Aug. 2004.
- (29) Ward, J. (2004). "Current Regional Strategic Transportation Planning Practice: Shortcomings and Solutions." Internal report. MIT.
- (30) Sussman, J., S. Sgouridis, and J. Ward. (2004). "An Engineering Systems Approach to Transportation Planning: Regional Strategic Transportation Planning as a CLIOS." Under review for publication at the 84th Transportation Research Board Annual Meeting. January 2005. Washington DC.
- (31) Committee on Developing a Regional Concept for Managing Surface Transportation Operations. Letter Report to Associate Administrator, Operations, FHWA. Transportation Research Board. 30 June 2003.
- (32) Sussman, J. (1999). "Regional ITS Architecture Consistency: What Should it Mean?" "Thoughts on ITS" Column, *ITS Quarterly*, ITS America, Washington, DC, Fall.
- (33) Transportation Research Board. (2004). "NCHRP Synthesis 326: Strategic Planning and Decision Making in State Departments of Transportation," Washington D.C.
- (34) U.S. DOT. (2004). "The Metropolitan Transportation Planning Process: Key Issues – A Briefing Notebook for Transportation Decisionmakers, Officials and Staff." Transportation Planning Capacity Board, Federal Highway Administration. <http://www.planning.dot.gov/documents/BriefingBook/BBook.html>. Accessed Jul. 2004.
- (35) Meyer, M., and E. Miller. (2001). *Urban Transportation Planning: A Decision-Oriented Approach*. McGraw Hill. Second Edition. (pg. 71).
- (36) Mostashari, A. and J. Sussman. (2004). Engaging Stakeholders in Engineering Systems Representation and Modeling. Presented at the MIT Engineering Systems Symposium, 29-31 March, at MIT, Cambridge, Mass.
- (37) Porter, M. (2001). "Regions and the New Economics of Competition," In *Global City-Regions*, edited by Allen J. Scott. New York: Oxford University Press, pp. 139-157.
- (38) Grube J.W. (2001). *Regional Competitive Advantage and Transportation Planning: An Extended ReS/SITE Framework*. Unpublished thesis for the Master of Science in Transportation, MIT.
- (39) Glasmeier, A and J. Kibler. 1996. "Power Shift: The Rising Control of Distributors and Retailers in the Supply Chain for Manufacturing Goods." *Urban Geography*, Vol. 17, No. 8, pp. 740-757.
- (40) Li, Y., and K. Polenske. Forthcoming. "Measuring Dispersal Economies." In *Entrepreneurship, Spatial Industrial Clusters and Inter-Firm Networks*. Trollhätten, Sweden: Universities of Trollhätten, Uddevalla (Papers from Symposium 2003), June 12-14.

- (41) Dutta, D. 2002 "Retail at the speed of fashion." Published online:
http://www.3isite.com/articles/ImagesFashion_Zara_Part_I.pdf. Accessed June 2004.
- (42) Landsberg, M. and P. Burkett. 1998. "Contradictions of Capitalist Industrialization in East Asia: A Critique of 'Flying Geese' Theories of Development," *Economic Geography*, Vol. 74, No. 2, pp. 87-110.
- (43) Osgood N., and S. Kennedy (2004). "Proposal for the MUST Center for Post-harvest Research and Technology." MIT (unpublished proposal)
- (44) PTP. 2004. Official website: http://www.ptp.com.my/ptp_features.asp
- (45) ZLC. 2004. Official website: <http://www.plazadosmil.com/ingles/index.asp>
- (46) European Commission. 2000. *White Paper – European Transport Policy for 2010: Time to decide*. Office of Official Publications for the European Communities. Luxemburg. Available online: http://europa.eu.int/comm/energy_transport/library/lb_texte_complet_en.pdf. Accessed: June 2004.
- (47) Miller, J. (2000). *Principles of Public and Private Infrastructure Delivery*. Kluwer Academic Publishers.
- (48) de Neufville, R., and A. Odoni. (2004). *Airport Systems: Planning, Design and Management*. McGraw-Hill. (pg. 70).
- (49) Krugman, R. P. (1996) *Rethinking International Trade*. MIT Press.
- (50) Niles, J. (2003). "Trucks, Traffic, and Timely Transport: A Regional Freight Logistics Profile." Mineta Transportation Institute. College of Business San José State University. San Jose. Available at: <http://transweb.sjsu.edu/publications/Freight.htm>. Accessed Aug. 2004.
- (51) MIT and Charles River Associates. (2001). *Mobility 2001: World Mobility at the End of the Twentieth Century and its Sustainability*. Prepared for the Sustainable Mobility Working Group of the World Business Council for Sustainable Development. Available at: http://www.wbcds.ch/web/projects/mobility/english_full_report.pdf. Accessed Aug. 2004.
- (52) Miller, G., D. Kiguel and S. Zielinski. (2003). *Moving Goods in the New Economy: a Primer for Urban Decision Makers*. Moving the Economy (MTE) and Canadian Urban Institute. Toronto, Canada.
- (53) MTE and ICF Consulting. (2002). *Building a New Mobility Industry Cluster in the Toronto Region*. MTE and ICF Consulting. Available at: http://www.movingtheeconomy.ca/content/MTE_New_Mobility_Study.pdf. Accessed Aug. 2004.
- (54) Schäffeler, U. (2002). "Summary of projects and results from topic: Inner Urban Freight Transport and City Logistics." PORTAL Consortium.
- (55) PORTAL (Promotion Of Results in Transport Research And Learning). European Commission funded project. <http://www.eu-portal.net>

- (56) Federal Highway Administration. (2004). "Public-Private Freight Planning Guidelines." Online guidelines: <http://www.fhwa.dot.gov/freightplanning/guidel2.html>. Accessed June 2004.
- (57) Allen, T., D. Nightingale, and E. Murman. (2004). "Engineering Systems: as Enterprise Perspective." Presented at the MIT Engineering Systems Symposium, 29-31 March, at MIT, Cambridge, Mass. Available at: <http://esd.mit.edu/symposium/monograph>. Accessed Jul. 2004.
- (58) Design Structure Matrix Website. (2004). Available at <http://www.dsmweb.org/>. Accessed Aug. 2004.
- (59) Problematics. (2004). PSM 32 Software Version 3.9j. Available at <http://www.problematics.com/>. Accessed Aug. 2004.
- (60) Browning, T. R. (2001). "Applying the Design Structure Matrix to System Decomposition and Integration Problems: A Review and New Directions." IEEE Transactions on Engineering Management, VOL. 48, NO. 3, AUGUST 2001. Available at: [http://sbufaculty.tcu.edu/tbrowning/Publications/Browning%20\(2001\)--IEEE-TEM%204%20DSMs.pdf](http://sbufaculty.tcu.edu/tbrowning/Publications/Browning%20(2001)--IEEE-TEM%204%20DSMs.pdf). Accessed Aug. 2004.
- (61) Sterman, J. (2000). "Business Dynamics: Systems Thinking and Modeling for a Complex World." McGraw-Hill / Irwin.
- (62) Ventana Systems, Inc. (2004). Vensim PLE v5.4b. Available at <http://www.vensim.com/>. Accessed Oct. 2004.
- (63) Dori, D. (2002). *Object-Process Methodology- A Holistic System Paradigm*, Springer, Heidelberg.
- (64) Huget, M.P. et al. (2003). "OPM/MAS Modeling Notation Source." Available at: <http://www.auml.org/auml/documents/OPM.pdf>. Accessed Dec. 2004.
- (65) Frankel, E. (2005). Federal Perspective on the topic: "Transportation from the Customer's Perspective: Mega-Trends in Delivering the Goods." Speech. Session 283. Monday, January 10th. Washington D.C. (Speech is available as webcast)
- (66) OECD (2004). "Transport and Spatial Policies: the Role of Regulatory and Fiscal Incentives." European Council of Ministry of Transport (ECMT). Round Table 124. Available at: <http://www1.oecd.org/publications/e-book/7504091E.PDF>. Accessed Dec. 2004.
- (67) de Neufville et. al. (2004). "Uncertainty Management for Engineering Planning and Design." Engineering Systems Monograph. Available at: <http://esd.mit.edu/symposium/monograph>. Accessed Jul. 2004.
- (68) Odylzko A. (2004). "The Evolution of Price Discrimination in Transportation and its Implications for the Internet." Review of Network Economics Vol.3, Issue 3 – September http://www.rnejournal.com/articles/odylzko_RNE_sept_2004.pdf. Accessed Nov. 2004.

- (69) Banister, D., D. Stead, P. Steen, K. Dreborg, J. Akerman, P. Nijkamp, and R. Schleicher-Tapeser, (2000). *European Transport Policy and Sustainable Mobility*. Routledge, London.
- (70) Kågeson, P. (2003) *Efficient charging of heavy goods vehicles: A critical review of the Commission's proposal for amending the Eurovignette Directive*. Comments by J. Dings, G. Lindberg, C. Nash. Swedish Institute for Transport and Communications Analysis. Stockholm. Available online at: http://www.sika-institute.se/databas/data/kortrapport_031028.pdf.
- (71) Kane L. and R. Del Mistro. (2003). "Changes in transport planning policy: Changes in transport planning methodology?" *Transportation* **30**: 113–131, 2003. Kluwer Academic Publishers. Netherlands
- (72) Georgescu-Roegen, N. (1971). *The Entropy Law and the Economic Process*, Harvard University Press, Cambridge.

Additional Bibliography:

- Kasarda J. and D. Rondinelli. (1998). "Innovative Infrastructure for Agile Manufacturers." *MIT Sloan Management Review*, Winter. pp. 73-82
- New, S., K. Green, and B. Morton. (2002.) "An Analysis of Private versus Public Sector Responses to the Environmental Challenges of the Supply Chain." *Journal of Public Procurement*. Boca Raton. Vol. 2. Issue 1. pp. 93-105.
- New, S.J., Green, K., & Morton, B. (1997, April). "The Sustainable Supply Chain: Theoretical Perspectives and Practical Developments." Paper presented to the International Sustainable Development Research Conference, Manchester, UK.
- Pendleton Todd and Joseph Sussman. "Regional Architectures: Strengthening the Transportation Planning Process."
- Porter, M. (2001). "Regions and the New Economics of Competition." In *Global City-Regions*, edited by Allen J. Scott. New York: Oxford University Press. (pp. 139-157.)
- Porter, M. E., and C. van der Linde. (1995a, September-October). "Green and Competitive: Ending the Stalemate." *Harvard Business Review*, 73(5), 120-134.
- Porter, M. E., and C. van der Linde. (1995b). "Toward a New Conception of the Environment-Competitiveness Relationship." *Journal of Economic Perspectives*, 9(4): 97-118.
- Sussman, J. (1996). ITS Deployment and the 'Competitive Region.' *ITS Quarterly*, ITS America, Washington, DC, Spring.
- Sussman, J. (2000). *Introduction to Transportation Systems*. Artech House, Boston.
- U.S. DOT. (1998). *Transportation Equity Act for the 21st Century. A Summary*. <http://www.fhwa.dot.gov/tea21/sumcov.htm>. Accessed Jul. 2004.
- U.S. DOT. (2004). "The Metropolitan Transportation Planning Process: Key Issues – A Briefing Notebook for Transportation Decisionmakers, Officials and Staff." *Transportation Planning*

Capacity Board, Federal Highway Administration.

<http://www.planning.dot.gov/documents/BriefingBook/BBook.html>. Accessed Jul. 2004

U.S. DOT, Freight Analysis Framework. Information available at the FHWA webpage:

http://ops.fhwa.dot.gov/freight/freight_analysis/faf/index.htm (Accessed Jul. 2004)

Zegras, C., J. Sussman, and C. Conklin. (2004). "Scenario Planning for Strategic Regional Transportation Planning." Urban Planning and Development. ASCE. Vol. 130. No 1.

Appendix I: Glossary of Key CLIOS Terms⁵⁴

Architecture:

A way of structuring institutional *and/or* physical relationships.

Actors and Actor groups:

Individuals, formal and informal organizations on the institutional sphere. Actor groups can be identified initially as equivalent to subsystem identification on the physical domain.

Bounding:

A crucial process where the decision on the extent at which the issue will be investigated is made. Occurs in Step 1 but is subject to iterative changes (expansion and possibly reduction if the problem proves too complex). Note: In system dynamics it is recommendable to start small and expand as you validate and understand the existing models.

Checklist:

Basic list including the prominent characteristics and issues of the system, defined in Step 1. The checklist serves as reminder of critical elements for later steps in the study.

CLIOS:

(Complex, Large-scale, Integrated, Open System) The object of study for the CLIOS Process. CLIOS complexity can be distinguished into internal, behavioral, and evaluative complexity (please see key concepts below). A CLIOS can be large-scale geographically or impact-wise. It is considered integrated due to tight interactions among subsystems and open because it is affected by external forces such as social, political, and economic influences.

“A class of systems of special interest in the socio-technical domain. Because of the many subsystems, the uncertainty in subsystem behavior and interaction and the degree of human agency involved, the emergent behavior of CLIOS is difficult to predict and often counterintuitive, even when subsystem behavior is readily predictable.”

CLIOS Process:

A framework that “can be used as an organizing mechanism for understanding a system’s underlying structure and behavior, identifying strategic options for improving the system’s performance, and deploying and monitoring those strategic options.” It is a holistic system approach, using both qualitative and quantitative methods to analyze a CLIOS. It is divided into 3 Phases and 12 steps.

CLIOS Sub-systems:

Individually identifiable entities that relate or are included to the CLIOS system

CLIOS Process advantages:

(i) structure for analysis, (ii) increased rigor and validity in analysis, and (iii) facilitation in identifying options on the *policy* sphere.

⁵⁴ CLIOS Glossary of terms as Appendix I prepared by the author yet based on team discussions as captured through internal memos by Sharon Lin and Ali Mostashari as well as two CLIOS papers: Dodder, Sussman, and McConnel (8) and Harrison and Sussman (9). The entries that are put in quotes are directly taken from the former.

CLIOS Stages:

Three distinct phases in the CLIOS Process; “*representation* of the CLIOS structure and behavior, *design and evaluation* of CLIOS performance and options, considering various strategic options and *implementation* of the selected options.”

Stage 1: describing/understanding the system

Stage 2: Creation and evaluation of options for improving system performance

Stage 3: Finalization of strategy

Note: The phases are not strictly sequential but on the contrary iterations are recommended to improve the process outputs.

CLIOS Steps:

Twelve smaller chunks of identifiable actions/jobs/functions within the stages.

CLIOS Process outputs:

The outputs from each phase of the CLIOS Process can be summarized as follows:

- Phase one (representation) – System description, issue identification, goal identification
- Phase two (design and evaluation) – Identification of performance measures, identification and design of physical performance improvement options, evaluation of options and uncertainties
- Phase three (implementation) – Implementation strategy for options, creation and evaluation of institutional performance improvement options, post-implementation evaluation

A summary of the summary:

- Strategic Alternatives
- Implementation plans
- Architecture structures
- Evaluation metrics – performance measures

CLIOS Christmas tree:

A framework for identifying the right analytic tools/methods for facilitating the CLIOS steps.

Note: this informal notation should be preceded by a more formal one (e.g. Tools identification?)

CLIOS Christmas tree ornaments:

Various tools/methods that can be used during the CLIOS process.

Common Driver:

Components shared across subsystems of the physical domain.

Components:

Individual units that make up a major subsystem. They may be policy levers, common drivers, or basic elements.

Component Diagram (also know as CLIOS diagram):

A qualitative diagrammatic representation of the interrelationships among the components of a major subsystem.

Complexity:

Internal (also known as combinatorial): The number of components in the system and the network of interconnections between them

Behavioral (also know as emergent or dynamic): The type of behavior that emerges due to the manner in which sets of components interact

Evaluative: The competing actions of decision makers in the system who have alternate views of “good” system performance. This type of complexity relates the links from the institutional sphere to the physical layer

Nested: Describes the situation of “a physical system [] inside a policy system, where both are complex and interdependent.”

Other references:

“The physical system can be envisioned as *embedded* within a sphere, representing the complex policy or institutional system.”

“[N]ested complexity” [occurs] when the physical system is being “impacted” or “managed” by a complex organizational and policymaking system, whether intentionally or not.”

Drivers:

Drivers are components common across subsystems in the physical domain. There are two types of drivers, including common drivers and exogenous drivers. They are drawn as diamonds in the component diagrams.

Elements:

Basic components of a diagram that are not defined as policy leavers, common drivers, or performance measures. The majority of components in CLIOS diagrams are basic elements. They are drawn as circles in the CLIOS diagram

Exogenous Drivers:

Forces that affect the system externally, i.e. the system has limited ability to affect. As common drivers, they may also link several layers of the physical domain, or unlike common drivers, they may simply be represented as a single component of a layer. They are drawn as shaded diamonds in the component diagrams.

Expanding:

The process of analyzing a subsystem down into its finer parts. It is used to develop a component diagram. Creating an additional sub-system out of one component if this component is critical for the system in order to gain detail. Expansion happens within the same subsystem layer.

Institutional Sphere:

Set of actors that influence the physical domain. It is a complex system in its own right, but its interaction with the physical domain forms the larger CLIOS.

Layering:

The further break-down of physical sub-systems within umbrella systems. It generates additional sub-layers. It is an organizing tool for dividing the physical domain out into relatively independent subsystems (called system layering), or layering the subsystems into relatively independent layers (called subsystem layering).

Layers (see subsystems):

Physical systems of general nature.

Links:

A general term to describe the connections between the components of the physical domain (defined as class 1), the components of the institutional sphere and the policy domain (defined as

class 2), or the components of the institutional sphere (defined as class 3). The class 2 links are also known as “projections.”

Mapping:

“The process of ‘flattening’ the Institutional Sphere into a surface in order to examine its parts. The Institutional Sphere is mapped into a plane for convenience to allow one to consider it.”

Nesting:

Separation of the system to the physical and institutional sphere. (See “nested complexity”)

Physical Domain:

“A system in its own right, it interacts with the institutional sphere to form the CLIOS. It represents an infrastructure or operating process of some sort that is used and managed by the institutional sphere. Often CLIOS involve a physical domain with technical components.”

Policy Lever:

Indicates the components in the physical domain that are directly affected by actors on the institutional sphere. These are drawn as rectangles in the component diagrams.

Projections:

“The links that connect the institutional sphere and the physical domain. The influence may be thought of as going in either direction: from the institutional sphere to the physical domain or vice versa. However, the projection coming from the institutional sphere can only go to the physical domain, projected as a policy lever and this projection cannot bounce directly back to the institutional sphere. For projections coming from the physical domain can come from any components on the layers and go back projecting on the institutional sphere. Projection is important as it forms close loops between the physical domain and institutional sphere, which are key sources for Step 5 to generate insights of the system.”

Strategic Alternatives:

Possibilities for improvement in the physical, technical, or institutional architectures. They are strategic in that they are selected and combined to form robust solutions for system improvement. Furthermore, they are chosen and shaped to maximize feasibility of implementation. are alternatives for improvement in the physical domain. They are strategic in that they are selected and combined to form robust solutions for system improvement. Furthermore, they are chosen and shaped to maximize feasibility of implementation.

Robustness (of strategic alternatives):

Options that perform well across uncertainties.

Subsystems:

Represent the layers of the physical domain and the institutional sphere. Identifying major subsystems is the first step toward representing a CLIOS.

