



A C H I L D R E N ' S H O S P I T A L  
I N A M E D I C A L C E N T E R

FOR WINNIPEG, CANADA.

Master of Architecture Thesis  
Massachusetts Institute of  
Technology

Ernest J. Smith. Sept. 1947.

C O N T E N T S

Acknowledgment	1 - 10
Introduction	1 - 4
The Problem	4 - 5
Physical Conditions	5 - 8
The Medical Center -- Whittier	8 - 10
The Children's Hospital	10 - 13
Program for the New Children's Hospital	13 - 18
Program Requirements for the Children's Hospital	18 - 34
Analysis and Solution	34 - 60
Conclusion	60 - 61
Bibliography	61 - 62

12-125 Chestnut St.,  
Cambridge, Mass.,  
September 1947.

William W. Wurster, Dean,  
School of Architecture and Planning,  
Massachusetts Institute of Technology,  
Cambridge, Mass.

Dear Dean Wurster,

This report, along with drawings, represents my thesis  
"A Children's Hospital in a Medical Center."

This thesis is submitted as partial fulfillment towards  
the degree of Master of Architecture.

Sincerely yours,

  
Ernest J. Smith.

## A C K N O W L E D G M E N T

For the generous help given to me during my research and preparations for this thesis, I wish to thank sincerely the following persons:

Wallace Grant, M.D., Superintendent of the Children's Hospital of Winnipeg, Manitoba, Canada.

H. Coppinger, M.D., Superintendent of the Winnipeg General Hospital, Winnipeg, Manitoba, Canada.

Eric W. Thrift, M. Arch., Director, Metropolitan Plan, Greater Winnipeg.

Mrs. Ruth Jerofsky, Assistant Chief of Social Service, Children's Hospital, Boston, Mass.

H. Pollack, M.D., National Authority on Children's Hospitals, Boston, Mass.

H.C. Stuart, M.D. Physician and Chief of the Child Health Division, Children's Hospital, Boston, Mass.

A. Davidson: Manager of special events, Children's Hospital, Boston, Mass.

Marshall Shaffer: Chief Architect, Hospital Facilities Section, U.S. Public Health, Washington, D. C.

P. Walker: Assistant to the Administrator, Children's Hospital, Boston, Mass.

Lee Forest Hill, M.D. Medical Director, Children's Hospital, Des Moines, Iowa.

Miss F. W. Stiles, S.E. Head Librarian, Mass. Inst. of Technology.

Miss M. H. Beale A. B. Assistant Librarian, Mass. Inst. of Technology.

Dennis H. Carter, B. Arch. Winnipeg, Canada.

For the valuable criticism given to me during the development of the design, I wish to thank the following staff members of the Mass. Inst. of Technology.

Dean W. W. Wurster

Prof. L. B. Anderson

Prof. H. L. Beckwith

Prof. R. W. Kennedy

Prof. A. C. Koch

N. Anderson



## I N T R O D U C T I O N

In the city of Winnipeg, Manitoba, Canada, the question of The Medical Center has been, for the past seven or eight years, a very live topic. Unfortunately, during the war period when other duties seemed more vital, little could be done in forwarding such an enterprise. Now that the war is over, renewed interest is being shown and some definite features have been established.

The "Manitoba Medical Center" has been incorporated by an act of Legislation. The board allows six represent-

atives for each member hospital. These are the Children's Hospital, St. Joseph's Hospital - a small general hospital in north Winnipeg, St. Boniface Hospital - a large general hospital in St. Boniface, Winnipeg's twin city across the Red River, and the Winnipeg General Hospital.

#### SITE

The area for the Medical Center has been defined as that lying between Sherbrook St. and Tecumseh St., running north and south and Notre Dame Ave. and William Ave., running east and west. The land here is perfectly flat and there is a coverage of eleven small city blocks or an area of approximately 47 acres.

Within this area there now exists the nucleus for the Medical Center. There is the Winnipeg General Hospital, with a bed capacity of 650, The Manitoba Medical College and the Central Tuberculosis Clinic. Surrounding these institutions and within the area are one or two churches, a few small commercial buildings, five or six brick apartment blocks and several old frame residences. It is proposed that most of these would be torn down for the Center's expansion. Building restrictions have been placed on this area and the Metropolitan Planning Commission of Greater Winnipeg have dealt with this location accordingly in the development of their Master Plan.



The location defined is located in an older residential neighborhood and is about 10 or 15 minutes from the main business section of Winnipeg.



#### BUILDING PROPOSED

The Winnipeg General Hospital is at present building a new Maternity Pavilion of 200 beds in the area on vacant lots lying between Pearl and Emily Streets facing Notre Dame Ave. This structure has apparently been located without relation to any overall plan of the Center. No such plan in fact, has been worked out. The General Hospital plans replacement of its oldest structure by a modern one and also plans additional stories over the administration block in the near future.

The Children's Hospital plans on moving into the area as soon as funds can be raised although no definite plans have been worked out as yet. St. Joseph's Hospital plans eventually on moving into the Medical Center. St. Boniface Hospital will not build in the area, but is a member of the Center because of the Center's relationship to medical education.

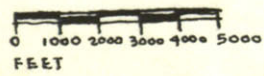
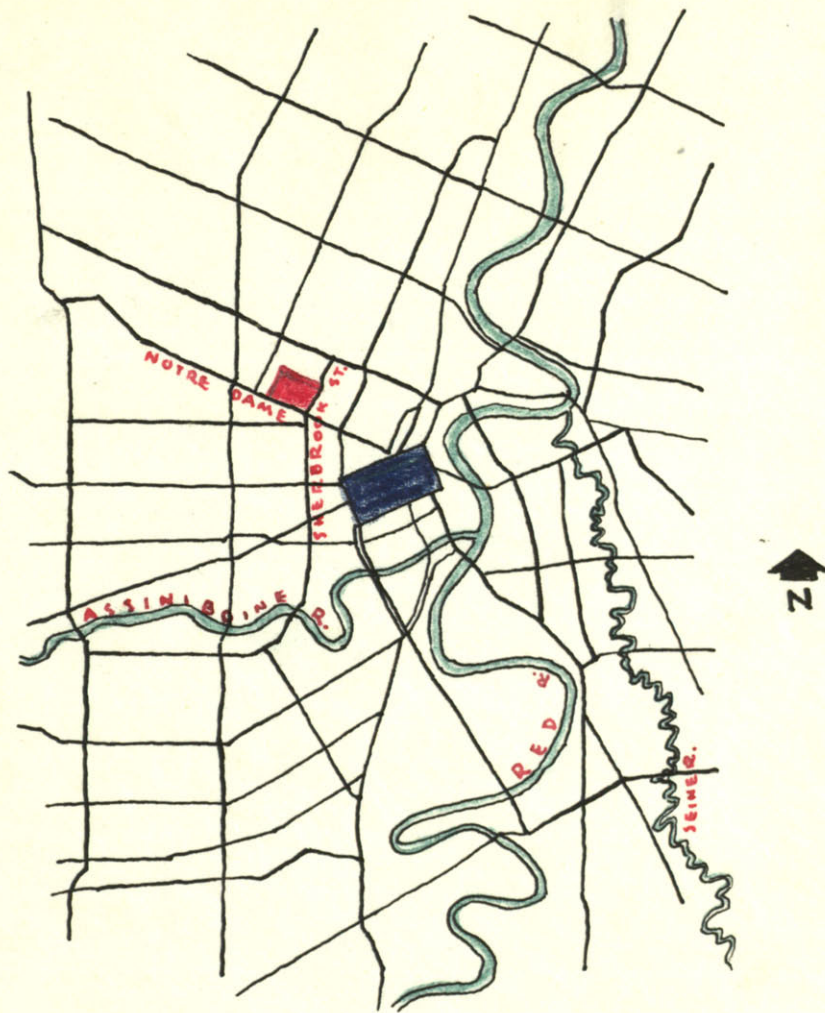
These are the only definite features of the Medical Center program to date. There has been some talk of building a new neuro-psychiatric pavilion and a convalescent unit in the area but nothing definite has been settled on this.



-  MEDICAL CENTER AREA
-  BUSINESS DISTRICT

# THE CITY OF WINNIPEG



THE MEDICAL CENTER AREA

- 1. GENERAL HOSPITAL
- 2. MEDICAL COLLEGE
- 3. T. B. CLINIC

## T H E P R O B L E M

It is proposed in this thesis to make a study of and design the building for the proposed new Children's Hospital unit as it is anticipated within the future Medical Center. An effort will be made to study the overall plan of the Center and to relate existing and proposed future units to one another and to the scheme as a whole. The completeness of this latter will depend to some extent upon the time available.

## P H Y S I C A L   C O N D I T I O N S

## THE CITY AND ITS CLIMATE

Often referred to as "The Gateway to the West," Winnipeg is known primarily as a wheat center. It is situated at the junction of the Red and Assiniboine rivers-- latitude  $49^{\circ} 53'$  N, longitude  $97^{\circ} 7'$  W. It is at the beginning of the vast western prairies. The city is characterized by its low buildings and broad streets.

The present population of Winnipeg is approximately 300,000. A large proportion of this population is employed by the railways and grain companies and many by light industry in

and about the city..

Winnipeg's climate is one of extremes. Although humidity is very low, the temperature varies from a high of about 95° in July to a low of -24° in February. The annual mean temperature is approximately 39° \*. There is a total annual snowfall of about 32 inches and the prevailing wind is North-West. The great majority of the days, both summer and winter, have a great deal of sunshine.

#### SOIL CONDITIONS IN WINNIPEG

The entire Winnipeg district is underlaid with limestone bed rock. This rock varies from as low as 100 feet below grade to as high as about 50 feet below grade.

Just above the good bed rock is a thin strata of a pink rock commonly called shale - really decomposed limestone. This is generally about 18 inches thick and must be cleaned off to get a good bearing for caissons. Above this is a deposit known locally as "hardpan." This varies in thickness from about 5 to 10 feet and if in a thick strata it has ample bearing capacity for apartments, office buildings, hospitals etc. of 7 or 8 stories. This "hardpan" is composed of boulders of granite and limestone in a mixture of sand, glacial clay and ground up limestone dust.

Above "hardpan" is a thin layer of soft white clay contain-

\* 1944.

ing considerable water and above this again is blue clay which is about 30 to 40 feet thick and fairly firm for pile foundations. Above this to the surface of the ground is clay. The top few feet of this clay is surface soil and yellow clay running into brown clay. There is a sharply defined yellow band of clay about 8 to 14 feet down which has been the curse of many of the old spread foundations in Winnipeg.

## T H E M E D I C A L C E N T E R - -

## W H A T I T I S

The function of the modern hospital may be divided into four main parts.

1. Treatment of the sick or the "Medical" function.
2. Training of medical students and nurses or the "Teaching" function.
3. Investigation or the "Research" function.
4. Constructive health buildings or the "Social" function.

From this the Medical Center has developed which is the logical economic coordination of hospital and health facilities.



Physically it is a hospital or group of hospitals and their dependencies, frequently linked with the medical college and arranged, if properly planned, for future expansion of any or all of the hospital functions. The Medical Center is generally developed around one or more institutions already existing which form a nucleus, and determine the site. Such a Medical Center is not necessarily an administrative amalgamation.

T H E C H I L D R E N ' S  
H O S P I T A L

The main function of a Children's Hospital is to give the best possible care for sick children. This was of course, the original purpose for founding such an institution. Today, however, there is the concept of a preventive service which not only prevents diseases and disabling conditions, mental and physical, but is prepared also to help the child realize his potentialities for growth and development.

The Children's hospital in a medical center has still further obligations.. It must train personnel to provide such service

and it should carry on research which will make its care more effective. Whatever the facilities or surroundings, the quality of care of the children depends upon the stress given to teaching and research.

In basic organization the children's hospital is essentially the same as an adult hospital. Much of the diagnostic and therapeutic equipment, dietetic facilities, administrative and staff needs are essentially the same as in the adult hospital but the nursing care and treatment technique for the child is quite different. "The adult may safely be treated as a child, but the converse can lead to disaster."\* The physiological difference between the child and the man require a vast amount of training, clinical knowledge and experience to diagnose accurately the physical signs of diseases in infancy and childhood.

Cross infection of children's diseases presents a real problem and nursing facilities must be designed to allow practice of isolation or semi isolation between patients.

Service for the adolescent is being given increasing attention by Children's hospital authorities. Adolescents have come to be known as the "forgotten age group" in modern medicine. Many of the conditions of adolescence are closely related to childhood, such as rheumatic fever and infantile paralysis, and provision for them is now considered essential in any modern Children's hospital.

\* Quotation by Sir Lancelot Barrington Ward in "The Child is Not a Little Man." -- pamphlet by The Children's Hospital Boston. April 1946.

Although some provision is usually made for the chronic and convalescent in the general Children's hospital, separate institutions are normally provided for this.

P R O G R A M M E F O R T H E N E W  
C H I L D R E N ' S H O S P I T A L

Some study has been done on a program for a new Children's hospital by the medical authorities in Winnipeg. The suggestions made by them were obtained and, with the guidance of Dr. Wallace Grant, superintendent of the existing Children's Hospital there, the following was formulated as the necessary elements of a program for the proposed building..

## BED CAPACITY

Past experience at the Children's Hospital and the General Hospital in Winnipeg suggests that a hospital of about 185 beds will prove sufficient for many years. This would allow for Medical, General Surgical, Eye, Ear, Nose and Throat, Infectious Diseases other than those requiring isolation in an isolation hospital, infants and prematures.

## SERVICES

### 1. Nursing.

A Children's Hospital School of Nursing will be conducted. The teaching of basic sciences would be combined with the General Hospital and, so far as possible, clinical lectures would also be combined. Ward practice will be carried on and also affiliation and post-graduate teaching.

### 2. Operating Rooms:

Completely equipped operating units will be necessary. The director of Anaesthetics of the Children's Hospital will be one and the same as the director of Anaesthetics at the Winnipeg General Hospital.

### 3. Laboratories.

Routine laboratory work in biochemistry and bacteriology and its branches will be combined with the General Hospital under the direction of the professors of Biochemistry and Bacterio-

logy respectively. Pathology, however, will be a separate service including the pathology of the newborn, and necessary laboratories will be provided for this. The reason for this decision as pointed out by the Children's Hospital advisors in Winnipeg, is that biochemical and bacteriological techniques are the same for the adult as for the child, but the problems of Pathology are, to a considerable extent, different. A number of research laboratories will also be required.

#### 4. Physiotherapy.

Physiotherapy equipment and space for the various necessary branches will be provided. Both the type and the approach to physiotherapy for children are different than for the adult and therefore cannot be combined with that of the Winnipeg General Hospital.

#### 5. X-Ray.

X-Ray equipment and space will be provided for. A separate technician will be necessary, but the Radiologist will be one and the same as at the General Hospital.

#### 6. Dietetics.

There will be a complete and separate dietetics service provided for.

### 7. Housekeeping.

There will be necessary space and facilities for housekeeping provided for.

### 8. Purchasing.

Coordination of purchase of standard supplies e.g. foods, linens, surgical dressings and most surgical and medical supplies, will be arranged with the General Hospital. Purchase of special supplies would be more satisfactorily arranged as a separate service and necessary space will be provided for this.

### 9. Heat and Steam.

This will be purchased from the central plant of the Winnipeg General Hospital.

### 10. Laundry.

It is suggested that this be centralized with that of the General Hospital, but that necessary linen and sewing rooms be provided.

### 11. Business Offices.

Administration will, to some extent, be coordinated with that of the General Hospital, but certain offices will necessarily be provided.



## 12. Record Office.

A separate Records Office will be provided in the new building.

## 13. Out-Patients' Department.

It is recommended by the Children's Hospital advisors in Winnipeg that there be a Medical Center or University Out-Patients' Department as a separate but single unit housing out-patients of all ages and run by the combined staffs of the Children's and the General Hospital. There is however, a general concensus of opinion among hospital planners and consultants that the children's out-patient department should be connected directly with the Children's Hospital itself. It has therefore been decided to provide space and facilities for a complete out-patient and public health department in keeping with the scale of the main building.

## 14. Nurses and Internes Quarters.

Living accomodation for about 100 graduate and student nurses and 10 or 15 internes will be necessary, but this will be taken care of in a separate building to be built in collaboration with the General Hospital within the Medical Center area.

P R O G R A M R E Q U I R E M E N T S  
F O R T H E C H I L D R E N ' S  
H O S P I T A L

The following requirements are to be planned for in the design of the building.

NURSING UNITS

: There is to be a total of 185 beds. These to be divided as follows:

Medical	--	comprising approx.	32%	or	59 beds.
Surgical	-	"	"	30%	or 55 beds.

Orthopedic - comprising approx. 25% or 46 beds.  
 Eye, Ear, Nose  
 & Throat " " 13% or 25 beds.

These divisions are a general mean and services should be able to take overflow of one or the other when and if necessary.

There may be one of two types of nursing division:

1. Children separated as to age grouping regardless of clinical division i.e. all clinics together.
2. Children separated as to clinical division and an age separation within each clinic.

The age division is to be as follows:

Infants (0 - 2 years)  
 2 - 6 years  
 6 - 12 "  
 Adolescents 12 - 18 years.

There must be a sex separation in all clinics for children over 6 years of age. Between 15% - 20% of all beds are to be private and semi private.

If type No. 1 above is decided upon, the following is to be used as a guide:

Percentage and Number of Beds for Each Age Division.

Infants 0-2 (including premature)	24%	or 44 beds with 8 isolation.
2 - 6 years	23%	or 42 beds with 7 isolation.
6 - 12 years	22%	or 49 beds with 5 isolation.
Adolescents	19%	or 35 beds with 6 isolation.

There will be an observation unit of approx. 24 beds for children of all ages and both sexes suffering from diseases which are infectious in nature.

: If type No. 2 is decided upon the following is to be used as a guide.

#### Percentage of Beds for Each Age Division:

##### Medical:

Infants	approx. 40%	with approx. 33%	of these isolation.
2 - 6 years	" 23%	" "	" " "
6 - 12 "	" 23%	" "	" " "
Adolescent	" 14%	" "	" " "

##### Surgical:

Infants	approx. 25%	with approx. 11%	of these isolation
2 - 6 years	" 15%	" "	" " "
6 - 12 "	" 23%	" "	" " "
Adolescent	" 17%	" "	" " "

##### Neuro Surgical:

(all ages, both sexes) 20% with approx. 25% isolation.

##### Orthopedic:

0 - 6 years	approx. 35%	with approx. 25%	of these isolation
6 - 12 "	" 35%	" "	" " "
Adolescent	" 30%	" "	" " "

##### Physical Therapy:

Infants approx. 40%  
All others " 60% with approx. 20% of these isolation.

##### Eye, Ear, Nose & Throat: (All ages and both sexes.)

Nose and Throat	approx. 40%	(isolation approx. 20%	of this)
Tonsil & Adenoids	" 20%	" "	" 10% "
Eye & Ear	" 40%	" "	" 20% "

Each Nursing Unit To Contain The Following Facilities:

- : Treatment Room:  
Large enough for examining table, instrument sterilizer, sink and storage cabinets.
- : Nursing Station:  
Centrally located and large enough for teaching charting to students.  
Medicine room off this with medicine cabinet and small sink.  
Nurses' toilet room.  
Supply closet.
- : Utility Room:  
To contain necessary work counter, sinks, bedpan warmers and sterilizers, storage cabinets and clothes chute.
- : Serving Kitchen:  
Centrally located, should contain sink, refrigerator, cupboards, electric plate etc.
- : Dish Washing Room:  
Next to serving pantry. To contain dishwasher and space for tray trucks.
- : Flower Room:  
Small room with counter and flower sink.
- : Supply and Linen Closet:  
Large enough to take a linen truck, shelves of varying width.
- : Cleaners' Closet:  
Door wide enough to take scrubbing truck; sink.
- : Stretcher Closet:  
Closet or alcove for taking wheel chairs and stretchers.
- : Lavatories:  
At least one lavatory in each public ward, semi-private room, and private room.
- : Sun Rooms:  
A sun room which can be easily controlled and used as a children's play room or dining room for ambulatory patients. Wash room off of this.
- : Guest Room:  
For parents staying overnight - one for each two or three nursing units. Large enough for two single beds,

dresser, closet and toilet facilities off of it.

- : Waiting Space  
A small waiting area for visitors for each unit.
- : Bath and Toilet  
Toilet and bath for male and female patients.  
Junior type fixtures where necessary.

## SURGICAL UNIT

- : Operating Rooms  
4 major operating rooms of approx. 300 sq. ft. each  
with necessary cabinets and equipment.  
2 of these rooms to be planned with viewing galleries  
for witnessing operations.  
1 minor operating room (approx. 165 sq. ft.)
- : Sterilizing Rooms  
Next to major operating room or between two with  
necessary cabinets, sink and equipment for steriliz-  
ing of instruments.
- : Scrub-up Rooms  
Next to operating rooms with access corridor.  
4 sinks sufficient for 2 operating rooms.  
Viewing windows from scrub-up into operating rooms.
- : Central Sterilizing and Supply Room (approx. 20' x 30')  
Equipped with sterilizers for dressing etc. and lined  
with counter and cupboards.
- : Sterile Storage Room (approx. 8' x 18')  
Off central supply room.
- : Clean-up Room (approx. 8' x 18')  
With counter and sinks necessary.
- : Surgical Supervisor's Office  
Space for desk and extra chair. Closet.  
Close to entrance of unit for control.
- : Doctors' and Nurses' Locker Rooms  
Space for 15 - 18 lockers in each.  
Treated as lounge at one end to take couch.  
Wash room with W.C., lavatory and shower.
- : Anaesthesia Rooms  
2 rooms for administering anaesthesia.

- : Stretcher Space  
Alcove or closet for about 4 stretchers.
- : Recovery Rooms  
2 recovery rooms large enough to take two wheel stretchers each.
- : Sterile Storage Room  
With cabinets for dressings and instruments.
- : Plaster Room  
Large enough to take treatment table, sink, cupboards, etc.  
Plaster closet off this.  
Splint closet off this.
- : Consultation Room  
Small room for doctors to discuss operating procedure.
- : Waiting Room  
For parents - close to recovery rooms.

#### X - RAY

Used by both in and out-patient departments..

#### Two Divisions:

Diagnostic  
Therapeutic

#### Diagnostic X-Ray.

- : 2 Radiography and Fluoroscopy Rooms (approx. 11'-6" x 18'-0")  
Each to take combination radiographic-fluoroscopy unit.  
W.C. and Lav. off of each room.
- : Dark Room (approx. 11'-6" x 8'-0" )
- : Waiting Room (approx. 300 sq. ft.)
- : 2 Dressing Rooms  
From waiting room into each Radiography and Fluoroscopy room.

- : Office and Viewing Room (approx. 13'-6" x 18'-0")
- : Film Filing Room (approx. 9'-6" x 18'-0")
- : Storage Room
- : Closet off Corridor  
For Mobile X-Ray machine.

#### Therapeutic X-Ray

- : Waiting Room (approx. 325 sq. ft.)
- : Doctors' Office  
Near waiting room for pre-treatment consultation.
- : Examination and Radium Treatment Room (approx. 10' x 15')
- : Small General Office (approx. 150 sq. ft.)  
With information counter, off waiting room to take  
typist's desk and filing cabinets.
- : Linen Room  
With shelving for linen storage.
- : Dressing Cubicles  
6 required.
- : Rest Room  
To take couch and 2 chairs.  
Toilet adject.
- : Deep Therapy Room (approx. 11'-6" x 18'-0")  
To take deep therapy unit and other equipment.  
Partition walls to be lead lined.
- : Superficial Therapy Room (approx. 11'-6" x 18'-0")  
To take superficial therapy unit and other necessary  
equipment. Partition walls to be lead lined.
- : Control Room  
Separate from either x-ray room to control both deep  
and superficial therapy units.

#### PHYSIO-THERAPY DEPARTMENT

To consist of:  
Electro-therapy



Exercise Room:  
 Hydro-Therapy  
 Occupational Therapy

: General

Waiting Room (approx. 120 sq. ft.)  
 Office (approx. 8' x 10')  
 To take desk, chairs and lockers.  
 W. C. and Lavatory off waiting room.

Electro-Therapy

- : 3 Treatment Rooms with small linen closet and soiled linen hamper each. (approx. 8' x 9') Each to take treatment table, bed table and chair.
- : 1 Treatment Room (approx. 10' x 9')  
 To take treatment table, paraffin tank, bed table and chair.
- : Exercise Room (approx. 700 sq. ft.)  
 To take a walker, portable stairs, various posture and ceiling mirrors, treatment table, stall bars and a non-skid mat on floor, etc.

Hydro-Therapy

- : Room (approx. 12' x 20')  
 To take a Hubbard Bath with monorail over, wheel stretcher, treatment table.
- : 2 Treatment Rooms (approx. 9' x 6')  
 Off Hubbard bath room.  
 Each to contain combination arm and let whirlpool, linen closet, soiled linen hamper and chairs.
- : Shower Room  
 Off Hubbard bath room.
- : Room with Pool (approx. 12' x 30')  
 With necessary exercising devices.

## Occupational Therapy

- : Room (approx. 20' x 30')  
To contain various work benches, bicycle, jig saw, etc.  
Ample storage cupboards with adjustable shelves.  
Sink and drainboard.  
Separate cubicle (approx. 6' x 6') with glazed partitions with desk and filing cabinet for supervisor.

## LABORATORIES

- : General Laboratory (approx. 19' x 20')  
Equipped with necessary cabinets, tables, sinks, etc.
- : Office (approx. 9' x 18')  
Off General Lab. To take 2 desks and filing cabinets.
- : Washing and Sterilizing Room (approx. 15' x 9'-6")  
Equipped with lab sink, work counter, sterilizers, etc.  
Off General Lab.  
Storage room off of this (approx. 9'-0" x 4'-0")
- : E K G, B M R and Specimen Rooms (approx. 11' x 18')  
To take hospital bed, table, Basal Metabolism and Electrocardiograph apparatus.
- : A group of Laboratories equipped for clinical pathology and research.

## PHARMACY

- : Pharmacy Room (approx. 15' x 18')  
To take large table, desk, sink and work counter.
- : Solution Room (approx. 9' x 15')  
To take work counter, sink, cabinets and rectangular sterilizer. Off Pharmacy.
- : Manufacturing Room (approx. 15' x 18')  
Off Pharmacy.  
To take large table, work counter, and cabinets.

## OUT - PATIENT DEPARTMENT

There must be a separate entrance planned for this department. Adjunct services such as X-Ray, Physio-therapy and certain laboratory services provided in the main hospital will be used also by the out-patient department.

- : Entrance Vestibule
- : Main Waiting and Play Room (approx. 1000 sq. ft.)
- : Appointment Office and Cashier (approx. 8' x 10')  
Desk and filing cabinets.
- : 2 Social Service Offices (approx. 8' x 10') each.  
Desk and 2 chairs.  
Waiting room for these (approx. 10' x 16')
- : 2 Public Telephones
- : History and Screening Room (approx. 8' x 12')  
Writing table, desk.
- : Public Toilets  
For both boys and girls (men and women)
- : Eye, Ear, Nose and Throat Clinic:  
Eye (approx. 20' x 10') with Dark Room off this (approx. 6' x 8')  
Ear, Nose & Throat (approx. 20' x 10') with necessary apparatus.
- : Dental Clinic  
2 operating rooms (8' x 10') each.  
Small lab.  
Small recovery room with storage closet.
- : Surgery (for minor operations)  
Small operating room (approx. 16' x 20')  
With operating table, storage cupboards and dressing room.
- : Utility Room (approx. 10' x 15')  
Off surgery with sink, B.P. washer.  
Refrigerator etc.
- : Immunization Room (approx. 15' x 8')

: Plaster Room:  
With plaster and splint storage.

: Medical Division

Examination Rooms for:

Heart

Diabetes

Allergy

Skin

Psychiatry

Feeding

Neurology

Epilepsy

Each of these clinics to have dressing rooms, waiting space, and Doctors' working facilities.

#### PUBLIC HEALTH DEPARTMENT

: Waiting Area (approx. 600 sq. ft.)

: Information Desk  
Off waiting area.

: Examining Room:  
Fairly large area with 7 or 8 examining rooms off of central attendants' area for routine checkups.

: Interview and Discussion Room (approx. 10' x 20')  
For interviews with mother and child in which students can listen.

: Office with Examining Room off  
2 or 3 required.

## ADMINISTRATION DEPARTMENT

- : Main Entrance Lobby  
Used by patients, visitors, medical staff and general public.  
Information desk in prominent location.
- : Waiting and Play Space (approx. 1500 sq. ft.)
- : Small Gift Shop
- : Public Toilets  
For men and women.
- : Admitting Office (public)  
Private for consultation.
- : Cashier's Office
- : Business Office (approx. 35' x 20')  
5 desks, filing cabinets, supply closet, vault.
- : Administrative Offices  
Administrator's office - private toilet and coat closet.  
Secretary's room - for administrator and director of nurses.  
Director of Nurses' office. Near administrator with private toilet and coat closet.
- : Examination Rooms (for admitting)  
Overnight rooms - 4 required - to take 1 hospital bed.  
Examiner's room - 2 required - to take examining table wash basin and desk.
- : Social Services  
2 Private offices with waiting for 3 or 4. Filing cabinet space.
- : Records Room (approx. 24' x 20')  
For live records. To take record cabinets and 2 or 3 reading desks.
- : Dead Storage Room (approx. 20' x 20')
- : Medical Library (approx. 400 sq. ft.)  
With small stock room off of this.
- : Conference and Board Room  
Would be combined with library.

- : Amphitheatre  
Small amphitheatre of approx. 60 capacity for special instruction lectures for students and internes - equipped with movie projector.
- : Staff Lounge  
For visiting medical staff.  
To take locker room, coat space and toilet facilities.
- : Nurses' Lounge  
With dressing room, shower and toilet facilities.  
Locker room for approx. 75 lockers.
- : Employees' Locker Rooms  
1 each for Male and Female.  
4 W.C.'s, 4 wash basins, 4 showers, 50 lockers each.
- : Switchboard and Doctors' Register  
Main switchboard possibly with information desk.  
In and Out board for doctors.
- : Student Lounges  
One each for student nurses and internes - equipped with toilet facilities and lockers.
- : Overnight Rooms  
2 only required - for 24 hour duty nurses.

#### KITCHEN

- : Main Room (approx. 55' x 35')  
For preparation, cooking, baking and serving.
- : Cart Washing (approx. 16' x 16')  
Equipped with counter and dishwashing equipment.
- : Special Diets Room (approx. 19' x 10')
- : Dietician's Office (approx. 10' x 10')  
Off main room with counter desk for 2, and filing cabinets.
- : Can Wash and Garbage Refrigerator  
Accessible off main room & close to exit.
- : Day Storage Room (approx. 12' x 16')  
Off main room.  
Shelving and frozen food locker.
- : Meat Preparation Room and Refrigerator (approx. 100 sq. ft)

- : Dairy Refrigerator (6' x 6')  
Off main room.
- : Fruit and Vegetable Refrigerator (approx. 7' x 11')  
Off main room.

#### DINING FACILITIES

Total dining space including serving space, staff, employees and nurses-- two sittings (approx. 1000 sq. ft.)

- : Professional Staff Dining Room  
With serving.
- : Non-Professional Staff Dining Room  
With serving.
- : Private Dining Room - for doctors.
- : Small Snack Bar-- for out-patients, parents, etc.

#### LAUNDRY

Laundry to be done at main laundry at the General Hospital.

The following rooms will be needed however:

- : Soiled Linen Room (approx. 12' x 14')  
Clothes chute from floors.  
Sorting tables.
- : Central Linen Room (approx. 20' x 25')  
Counter and shelving.
- : Sewing Room and Housekeeper's Room (approx. 10' x 20')  
Off central linen room. To take counters, tables,  
cabinets, and sewing machine.

#### MORGUE

- : Morgue Room (approx. 12'-6" x 18')  
To take examining table.

- : Mortuary Refrigerator  
To take 4 bodies - off morgue.
- : Museum (approx. 18' x 14')  
Equiped with specimen cabinets -- off morgue.
- : Shower Room  
Off museum. Equiped with shower, W.C. and Lavatory.
- : Autopsy Room (approx. 18' x 18')  
To take autopsy table with sink, work counter,  
stretcher, observation stand and scrub sink.  
Should be room here for student instruction.

#### CENTRAL STORE ROOM (total of about 3600 sq. ft.)

- : General Storage (approx. 60' x 40')  
With counters and adjustable shelves.
- : Case Storage and Bulk Food (approx. 20' x 30')  
Wood platforms and adjustable shelves.
- : Issue and Receiving Room (approx. 10' x 15')  
To take desk, counter and filing cabinets.
- : Furniture Room (approx. 15' x 30')  
With racks for storing beds, mattresses, chairs etc..
- : Anaesthesia Storage (approx. 10' x 15')  
Close to service entrance. Explosion danger here.

#### EMERGENCY DEPARTMENT

- : Vestibule  
To take 2 wheel chairs and 2 wheel stretchers.
- : W. C. and Lavatory (off vestibule)
- : Supply Closet (approx. 6' x 8')
- : Office and Waiting Room (approx. 8' x 10')  
To take desk, 4 chairs and files.
- : Utility Room and Bath (approx. 7'-6" x 18'-0")  
To take sink, Cupboard, B.P. washer etc.



- : Emergency Room (approx. 15' x 18')  
To take necessary equipment. (emergency)
- : Overnight Rooms  
4 required to take 1 hospital bed. (These can be same rooms as mentioned in Admitting Department.)

#### AMBULANCE GARAGE

To take two ambulances.

#### HEATING AND VENTILATION

- : Mechanical Equipment Room (approx. 30' x 30')
- : Engineer's Office (approx. 10' x 15')
- : Maintenance Shop (approx. 20' x 15')

## A N A L Y S I S A N D S E O L U T I O N

## THE SITE

The Manitoba Medical Center area as defined, appears to be in a reasonably good location in the city. It is easily accessible from, and yet not too close to, the main business section and the district immediately surrounding appears to be one which would be well served by such facilities as out-patient clinics and public health departments. It is made up largely of a residential area whose occupants would not likely be able to afford private medical care, or who could easily go great

distances to reach such facilities.

Although the choice of the site was pre-determined due to the existing nucleus of buildings, it is felt that the location is essentially a good one.

The actual layout of the area itself (i.e. street system etc.) is, however, poor as it now stands. The street system in the area carries out the rectangular grid pattern of the city layout resulting in far too many through streets and chopped up land, making good sites for future building almost impossible.

In studying the site an attempt was made to isolate the entire medical center area from the surrounding traffic and to keep the number of accesses to a minimum. It is proposed to clear the area of all old existing frame houses, apartment blocks and the two churches. There was a definite question about the churches as they would doubtlessly be difficult to have removed. They are on the periphery of the area and would perhaps not interfere too much. One is quite old however, and an eyesore, and would have to be demolished at some future date anyway. It was therefore decided to assume that the both churches would be removed.

A new street scheme is proposed which will allow additions to the present general hospital and to the medical college. This scheme makes use largely of existing streets, but many

of course have been eliminated to allow larger areas of free land for future buildings.

The areas chosen within the center for the Children's Hospital unit is on the south side, adjacent to the Notre Dame boundary thoroughfare. This location is adjacent to the Maternity hospital, a connection which was thought desirable, and is also within easy reach of the existing boiler houses from which the authorities propose to purchase heat and steam. The fact that this location puts the hospital rather close to a major thoroughfare (Notre Dame Ave.) was considered, and it was felt that some slight traffic noise would not bother children patients too much. Authorities claim that noise does not bother a child patient nearly as much as it does an adult.

#### THE BUILDING

As mentioned previously, the basic organization of a Children's hospital is essentially the same as an adult hospital. There is the problem of serving both in-patients and out-patients with auxiliary service departments; of organizing the many lines of circulation for patients, for visitors and for supplies etc. The main difference comes in the actual nursing care and treatment of the child -- a difference which is taken up largely by the personnel who run the hospital, but also of course, in the actual planning of the

facilities themselves.

#### NURSING UNITS

The nursing unit is the most important element of the many comprising the hospital. It is the space where the patient actually lives during his stay and involves the various services and auxiliaries which are necessary for ministering to wants and needs.

In a children's hospital there are two methods of grouping patients. Either the children are divided into age groups, or they are divided as to clinical services -- (i.e. - all surgical patients together, all medical patients together, etc.) Both methods are used and some authorities prefer one and some the other.

In the solution, the age group division was finally decided upon after considerable thought and research. This method is now used by the present Winnipeg Children's Hospital -- a consideration of some importance. Authorities agree that



children of 2 to 6 years old are happier together than mixed with 10 and 12 year olds. In the teaching hospital age grouping seems to hold a preference. When internes go through their training with such a setup, they come into contact with children of all ailments -- something which is difficult to accomplish if the clinical division is used. That is, during his relatively short period of training, the interne would not be able to go through a surgical unit, a medical unit, an orthopedic unit etc., very thoroughly.

There are certain disadvantages to the age grouping. Surgical patients are frequently "clean" from the standpoint of respiratory infection, while medical wards have a higher percentage of "dirty" patients. Small units and good technique help to prevent the spread of infection of course. There is the question of different nursing care for an orthopedic case for example, than for a medical case which may cause difficulties in the nursing set-up in the age group unit. Some authorities claim however, that this "splitting up" is even preferable. The size of the hospital was another consideration. It was felt that even in a hospital of approximately 200 beds, the clinical division would hardly be justified -- the number of beds per division would be too small to warrant it.

The size of groups of children is another controversial question. Cross infection from one child to another is a very real problem and by keeping the group small it is large-

ly overcome. It is generally agreed that ward patients should be limited to 4 per room or possibly 6 per room for the very small children. Within the ward itself the cubicle system is considered essential in which each bed is divided by a glazed partition approximately 7'-0" high with curtains which can be pulled across the ends. New admissions need to be isolated until their condition is determined and very ill children need care in a room alone whatever their financial status. Although some private rooms have been provided in the solution, it is felt that the sharp distinction between ward patients and private-room patients will eventually disappear.

Best orientation for hospital beds is considered to be south-southeast and south-southwest. In the solution a south-southwest exposure is used and was aimed at for all beds. The nursing units are limited to two per floor with the nurses' stations situated to save nurses' steps. The number of beds per nursing unit is preferred to be somewhat smaller for children than for adults and should range around 20 to 25 beds. The system of an off-set corridor was considered a good one with all patient rooms on one side and all service rooms on the other -- facing primarily north.

Each nursing unit is cut off completely from public circulation and visitors' waiting areas are planned outside the units themselves. A sun room for each nursing unit is planned to prevent children leaving their area. Three or four

guest rooms were considered a worthwhile innovation where parents could stay overnight if and when necessary.

#### SURGICAL UNIT

The traditional location for the surgical unit has been on the top floor of the building. This is advantageous to the point that it is a terminal point of the building and is isolated-- something which is necessary for this department.

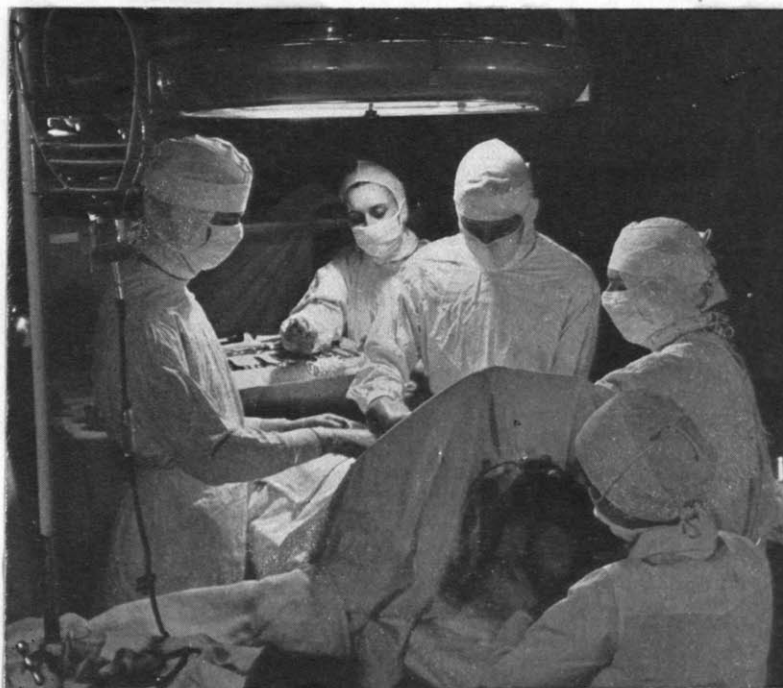

Many authorities now contend that the surgical unit should be located so that it is horizontally contiguous with the surgical nursing units. In a normal general hospital this is undoubtedly preferable. In the development of the solution however, as has been mentioned, nursing was split by age groups rather than by clinical service. To have surgical beds horizontally contiguous with the surgical unit thus became impossible and certainly not essential. In fact, by making such a decision, the surgical unit could go almost anywhere in the building (vertically that is) provid-



ed it met the requirements of being isolated and being easily accessible from emergency and from the nursing units by elevator.

The question of natural light for operating rooms was studied, and many authorities now claim that the uncontrollable, undependable natural light is undesirable if anything and that artificial light has to be used during operations anyway.

In the solution, it was found that by burying the operating rooms in the center of the building with no natural light, a plan could be developed which would enable the whole functioning of the hospital to be more tightly integrated making horizontal distances as short as possible. This also gives a compactness which is desirable in the heating problem of buildings in Winnipeg. The surgical unit is placed low in the building (it is on the second floor) thus allowing the necessary spreading out for its facilities. Above the second floor and on up, the structure could then be stepped back and narrowed in order to admit natural light to other services which needed it.

Operating viewing galleries should preferably be reached without going through the surgical unit. This fact eliminated the possibility of any portable type which is placed right in the operating rooms and it was felt justifiable to plan on viewing domes over the operating rooms which are

accessible from the floor above. Observers can use binoculars if desired and a two-way address system can be installed between the gallery and surgeon.

## X - RAY

X-rays are used in hospitals both for diagnostic and therapeutic purposes. Radium is employed for therapeutic purposes only. Radiology is the term applied to diagnostic and therapeutic uses of X-rays and radium, while roentgenology refers to X-rays only.

## DIAGNOSTIC X - RAY

One of the questions which came up with diagnostic X-ray was whether or not it was undesirable to separate it from therapeutic X-ray. Nothing was found during the course of research which said that it should not be separated and it was found in the solution that definite advantages could be gained by making a separation.

This department, along with the operating rooms, is one which can operate as well if not better without

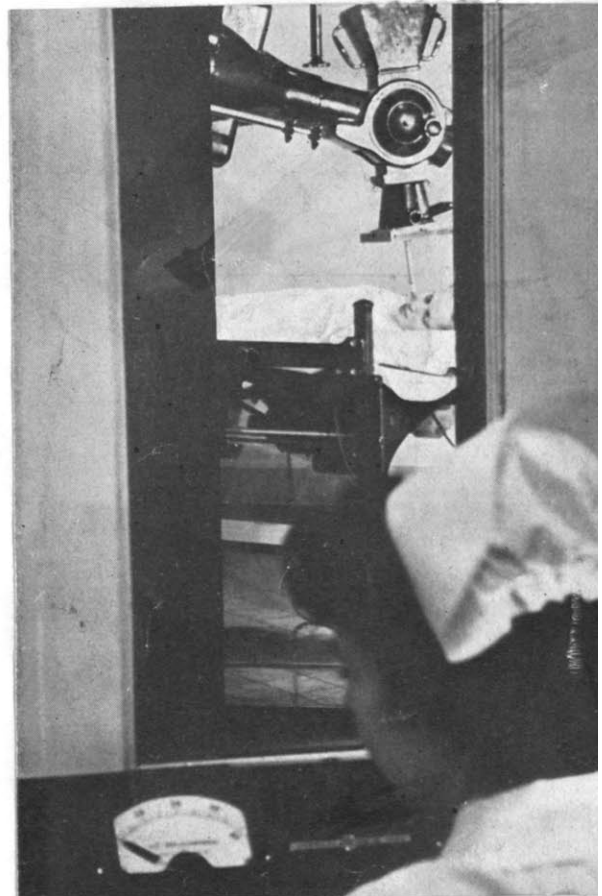

any natural light. Like the operating rooms, it is located in the core of the building without any outside light. It is situated on the ground floor under the operating suite, where it is easily accessible from the emergency department and from both in-patients and out-patients.

#### THERAPEUTIC X-RAY

This department needs good outside light and should preferably be in a cul-de-sac location.

In the solution it is placed in the treatment zone of the building -- on the fourth floor. It is easily accessible from both in and out-patients by means of elevators and the horizontal distances to it are short.

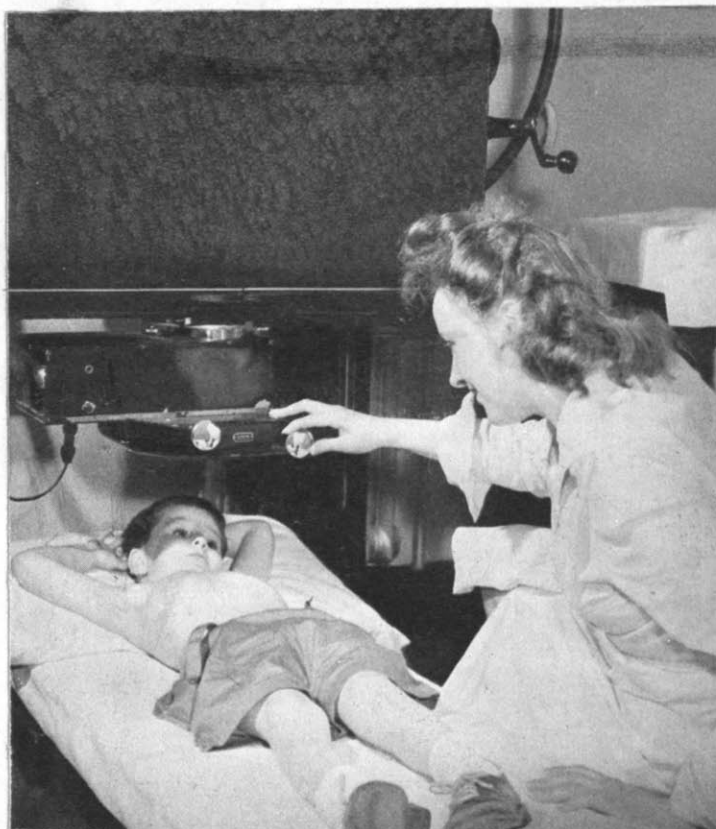

## PHYSIO - THERAPY DEPARTMENT

Physio-therapy is part of the division of physical medicine involving various mechanical means for stimulating normal physiological processes. It is part of the process of rehabilitation. The aims are not only to restore function in organs like arms, legs, muscles etc., but simultaneously to restore mental equilibrium. This department again should be situated to be equally available to both out-patients and in-patients.

In the solution all branches of physio-therapy are grouped together on one floor with the exception of the occupational therapy room which is on the X-ray therapy floor. All are easily accessible from both in-patients and out-patients by means of elevator.

## HYDRO THERAPY

The hydro therapy pool governed, to quite an extent, the location of this section. The room for the pool required additional height and for this reason was limited to either the ground floor, free of anything above, or to the top floor. The top floor of the treatment wing worked out to be the most logical, as too many other facilities were better located on the ground floor.



H U B B A R D B A T

## OCCUPATIONAL THERAPY

Good light is required for this and it is best located in conjunction with other therapeutic facilities.



## LABORATORIES

Hospital laboratories form a department of hospital work which cannot very well be standardized. In the teaching hospital there are additional research laboratories required for students in addition to the normal general laboratories used in the routine work.

In the solution, the general laboratories are located in the service wing on the third floor. These are adjacent to the elevators making servicing to and from them easy. They are also easily accessible from out-patients.

A few clinical laboratories are provided on the same floor as the general laboratories and several research laboratories are located on the floor above. All laboratories have the advantage of east light.

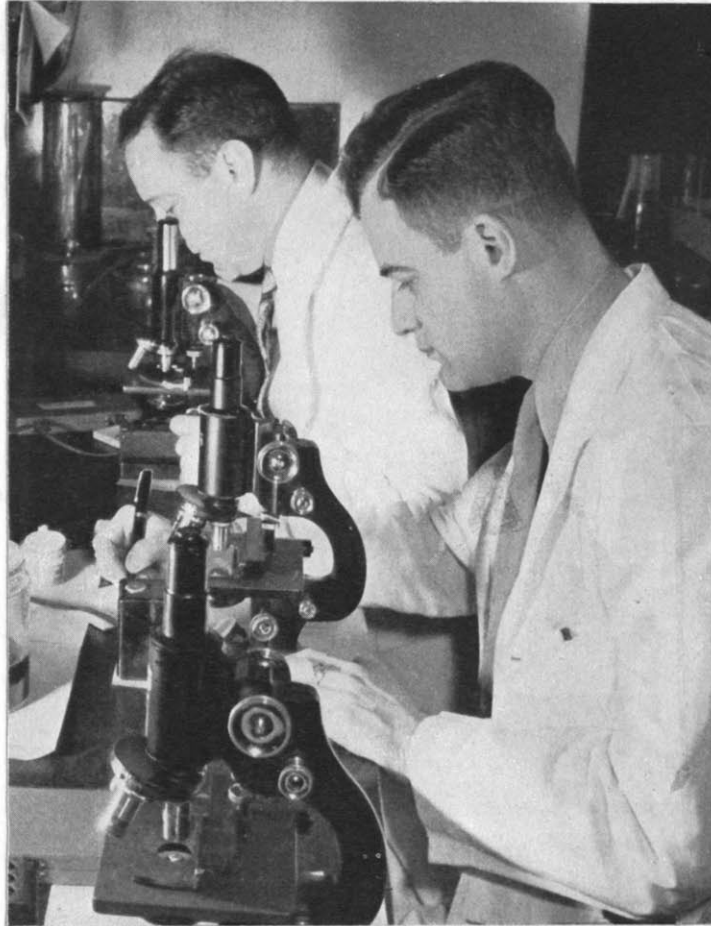

## PHARMACY

The pharmacy is a department which must be directly connected to the out-patient department, as it is used mostly by out-patients. It is here that prescriptions are filled out for patients upon leaving the hospital.

In the solution the pharmacy is located on the ground floor directly off the out-patient waiting lobby and is also easily accessible from the in-patient waiting room.

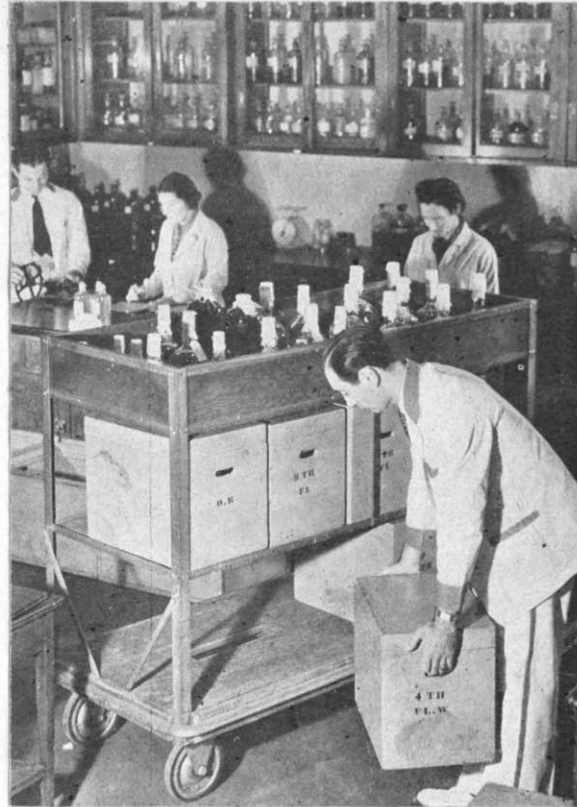



## OUT - PATIENT DEPARTMENT

This is one department which is in an expanding stage in hospital organization and certain assumptions have to be made in forming the number and extent of its facilities. As mentioned previously, there must be a direct connection from this department to the auxiliary facilities of the rest of the hospital. Ample waiting area is needed for the out-patient department -- it is a department of waiting.



It was felt that the location of the out-patients should be on the ground floor or at least very obviously available from the ground floor. In the solution a split level scheme was resorted to where patients go half a flight up and half a flight down. Ramps for wheel chairs or baby carriages supplement the stairs. By using such a scheme the whole plan of the out-patients is considerably compacted and good light is available to rooms in the lower level as well as in the upper level. Extension in the future of the out-patient wing is easily accomplished.

## PUBLIC HEALTH DEPARTMENT

This department like the out-patient is one which is in a growing stage. Preventive medicine is becoming increasingly popular and necessary and particularly so where it is connected with children.

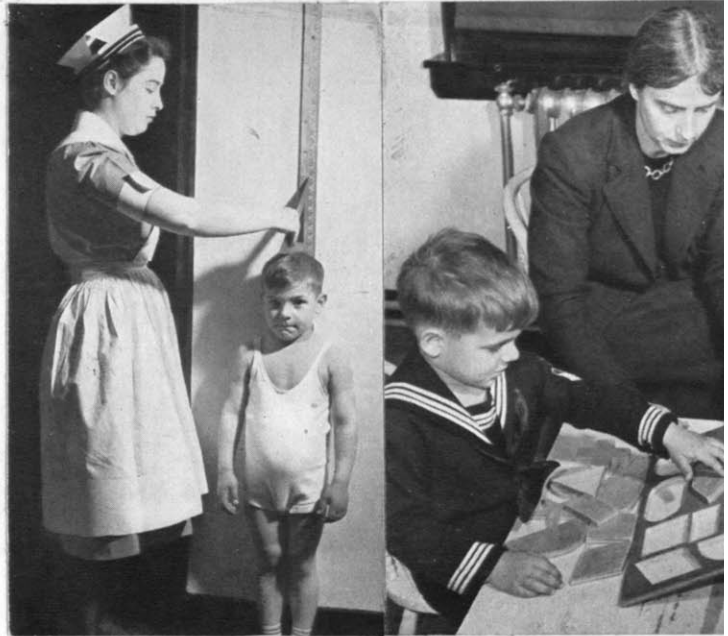

In the solution, Public Health has been located in the out-patient wing. It has its own waiting area -- something which is considered desirable as presumably well patients should not have to wait in the same area as the sick and ailing. Like the out-patient department this can easily be extended in the future.

## ADMINISTRATION DEPARTMENT

Although it is likely that much of the administration would be done under a central control of the entire medical center, some facilities obviously had to be provided.

The business offices and medical records are best located so that administration of both in and out-patient departments can be carried on within the same general

area. Information desks and cashiers should be located close to entrances and waiting areas and admitting and social service offices should preferably feed from the business administration section. Lounges for visiting doctors and staff and for nurses, student nurses and internes should be located so that these personnel do not have to cut through the main lobby or waiting area when arriving or leaving the building. The medical library should be easily accessible to medical staff in the hospital.

In the solution the business offices form a block connecting in and out-patient waiting areas, with the records room eas-



ily accessible from both departments. The directors' offices, lounges and medical library are situated in a separate one-story wing connected directly to the center of the hospital. This wing can be entered without going through any central public areas.

## KITCHEN

This department is too frequently planned in a dark basement area with little light or ventilation. For such an important function as feeding, greater stress should be given to its proximity. It should be so placed that food supplies can be easily brought in and garbage taken out. It should be organized in such a way that the food going from the kitchen can be taken out and up to floor kitchens crossing as few lines of traffic as possible.



The site chosen for the hospital is perfectly flat, and putting the kitchen in any space below grade seemed out of the question. In the solution it is arranged on the ground floor where service is easy to it and food travel to elevators and staff dining is direct. After a study of methods of feeding patients, the decentralized service was thought best. In this, food is taken in bulk in heated carts to the floor

kitchens and there it is made up on trays and wheeled to the beds in tray carts. All dishes are washed on each floor and only food carts return to the kitchen. Facilities for cart wash and staff dining dish washing are provided.

#### DINING FACILITIES

There is some controversy as to whether or not professional staff should eat with non-professional staff. The tendency today is for simplification. The dining rooms should if possible face a pleasant view and be located where they can be easily reached from staff lounges and lockers.

In the solution there is separate provision for doctors, professional, and non-professional staff. It is thought that these areas could be divided simply by light opaque glazed partitions not necessarily to the ceiling. They are located on the south side of the building overlooking a children's play area and are easily fed by a servery which works directly off the main kitchen.

A small snack bar has been provided close to the out-patients' department for waiting patients to have a light lunch.

#### LAUNDRY

The actual laundry service is to be purchased from the Winnipeg General Hospital in the area and no provision for a

laundry unit is necessary.

The central linen room and housekeeper's quarters should be easily accessible by elevator at least, and the soiled linen room should be reached from the service entrance for picking up dirty laundry.

These facilities have been located in the basement and meet the above conditions.

#### MORGUE

The removal of the deceased from a hospital should be done as unobtrusively as possible.

In the solution this department is planned for in the basement where the service elevator connects to it. Bodies can be easily removed from the service entrance.

#### CENTRAL STORE ROOM

There is a distinction between stores and storage. Stores are newly bought goods which have to be distributed sooner or later to their respective departments. Storage is material belonging to the various divisions of the hospital which is stored for future use.

The steward is responsible for receiving goods, accounting and distributing them. This department is logically located in the basement.

In the solution stores and storage are located in the basement and are in close proximity to the service entrance.

#### ADMITTING AND EMERGENCY DEPARTMENT

The principal functions performed by this division are as follows: kits are prepared for ambulance physicians or attendants; ambulance calls are received and ambulances dispatched; patients are received and examined; patients suffering from major or minor injuries are given emergency treatment; a child may be detained here for purposes of observation and more careful diagnosis.

This division should be easily accessible to the emergency entrance and to both in and out-patient entrances. It should be located near elevators so that patients in need of immediate surgery can be taken there without delay.

In the solution the above requirements have been well met and the diagnostic X-ray also feeds off this department.

#### AMBULANCE GARAGE

This should be located off the general service area of the hospital.

## HEATING AND VENTILATION

As previously mentioned heat and steam is to be purchased from the central boiler plant in the area. Rooms from which heat is distributed within the building and in which air conditioning equipment, refrigeration, emergency electric plant are housed, are best located in a central area in the basement of the building.

A hot water radiant heating system is proposed throughout the building and air conditioning will be a definite necessity in such places as operating rooms, diagnostic X-ray, rooms, pharmacy etc.

Although some estimates on the installation of radiant heating panels show a cost increase of about 25 percent over a steam convactor heating system, so far as radiators and risers are concerned, it is claimed that the heating plant can be smaller and that panel heating requires a good deal less fuel than the traditional methods of heating. This method of heating would be particularly well suited to the nursing units where convalescing children may be playing on the floor.

## CONSTRUCTION

The building will be of reinforced concrete frame construction. It is proposed to use a one way combination floor with



tile fillers (concrete ribs) which will frame into flat band beams which carry continuously through the length of the building without unsightly cross beams.

This would eliminate the necessity of hanging ceilings and would reduce the floor to floor heights from 6 to 10 inches-- a big saving in construction cost.

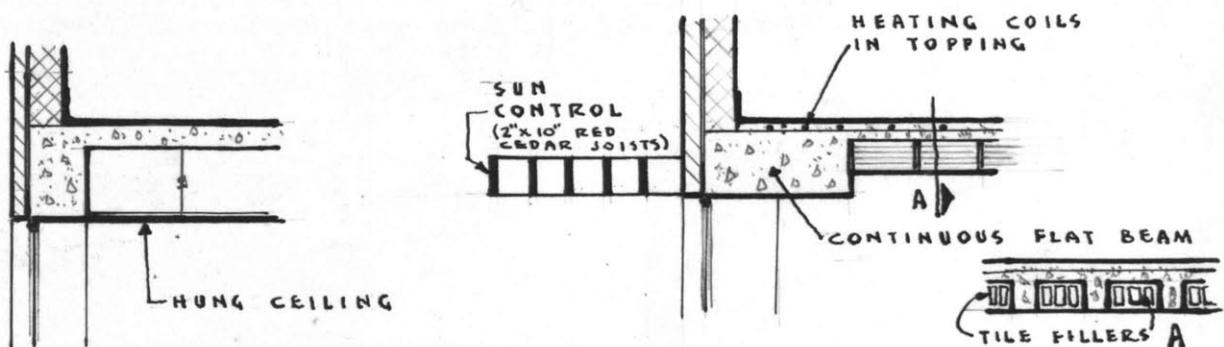

TRADITIONAL  
METHOD

SUGGESTED  
METHOD

A good buff brick is obtainable locally and it is proposed to use this on the exterior of the building. This would be backed up with hollow tile. Tyndal limestone (grey) will be used for sills and some trim. This is also a local product, obtained from Tyndal, a small town just east of Winnipeg, and is an excellent material.

## FOUNDATIONS

In the new Maternity Pavilion, which is at present being erected in the immediate area of the proposed Children's Hospital site, boring tests were made and a thick layer of hardpan was encountered about 25 to 30 feet below grade. Caisson foundations to this hardpan have been used here.

It seems logical therefore to assume that the same type of foundation should be used for the proposed building.

## INTERIOR FINISHES

The question of interior finishes in a hospital is something which requires considerable experience.

### Floors

The type of floor finish is determined by the use to which the space is put. Cement floors with integral hardener are satisfactory for working spaces such as store rooms, and basement corridors. All "wet" rooms such as toilets, baths and utility rooms etc., will best be finished with terrazzo. Operating rooms will also be finished with terrazzo. In patient rooms, and nursing corridors asphalt tile or linoleum are satisfactory as they are good wearing and resilient.

### Walls.

In the kitchen, receiving room, store rooms and stairways, salt glazed tile is considered good. This is also suggested in "wet" rooms and operating rooms at least to a 6 or 7 foot wainscot height with keene's cement plaster above.

Patient rooms and sun rooms will be plastered and painted.

### Ceilings.

Acoustic treatment is a necessity in almost every room in the hospital. Acoustic plaster will be used in most of the service rooms but patient rooms and nursing corridors should be treated with a more efficient acoustic tile.

### Color.

Color is a subject which is extremely important and too little is known of it. The whole scheme should be kept light and airy as possible using pastel yellows, blues and rose colors in various combinations.

The entrance lobbies and waiting areas need particular study as it is here that the child gets its first impression. Such things as Disney murals on the walls and various patterns in bright colors on the floors will be used.

The wards should be kept as "homey" and "playful" as possible with the use again of some caricatures of Disney or fairy tales on light yellows and blues and greys.

## C O N C L U S I O N

Throughout the whole scheme there has been an attempt, first of all, to integrate the Children's Hospital with the overall plan of the medical center.

In the building itself, study indicated that the plan should be compacted horizontally and go up vertically in order to attain the desirable relationship between the many elements.

The fact that the building is to house sick children was kept in mind constantly. At the same time however it was realized that it is the adult who has to work in it.

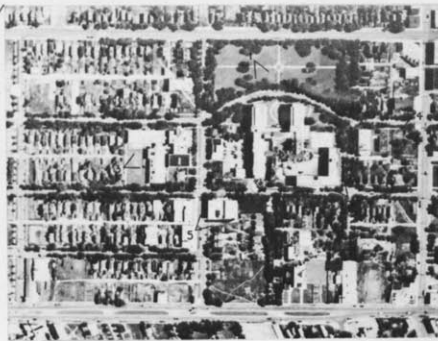
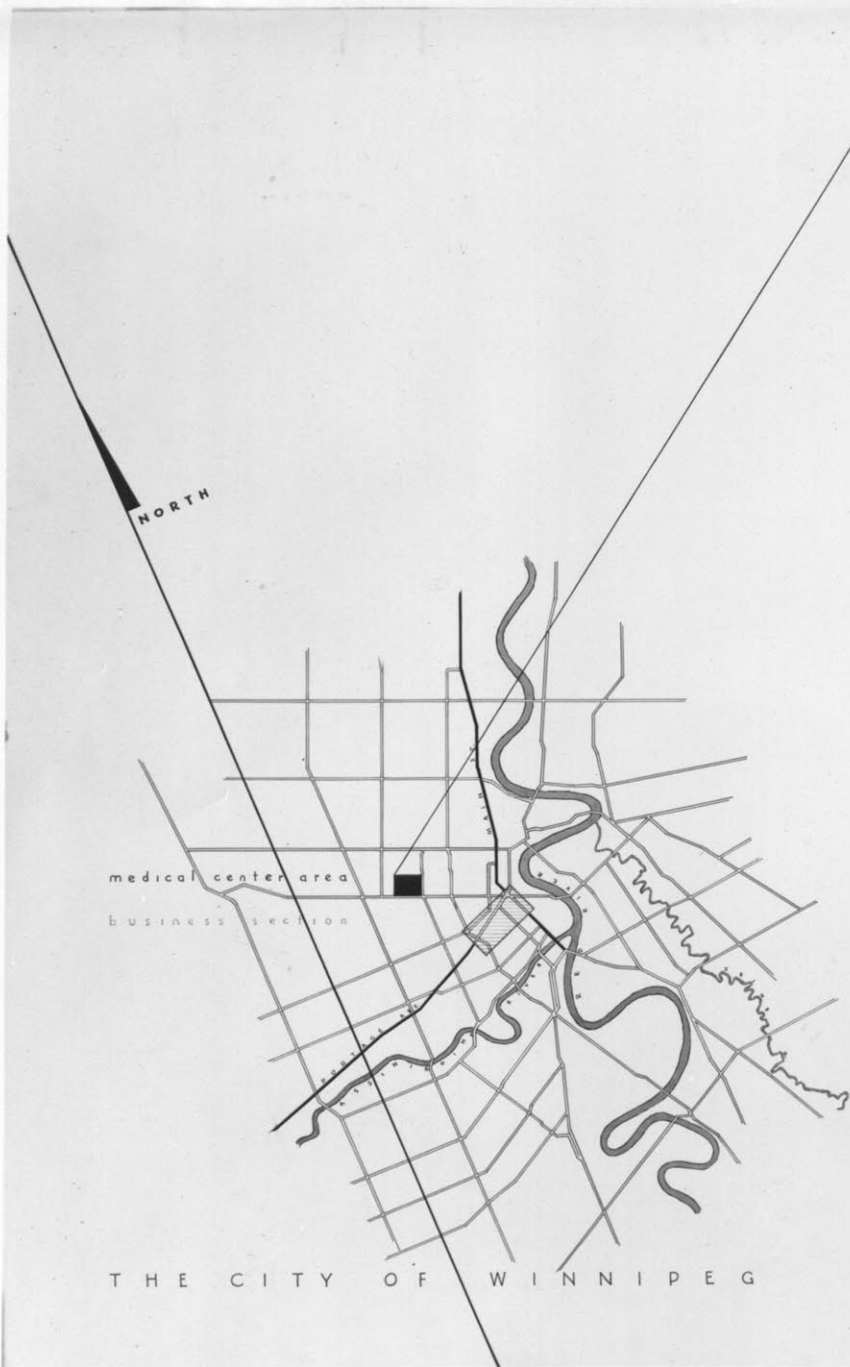

1. GENERAL HOSPITAL



2. NURSES' HOME



3. MEDICAL COLLEGE



4. T. B. CLINIC



5. BOILER PLANT



# A CHILDREN'S HOSPITAL in a medical center

THESIS FOR M. ARCH. DEGREE  
MASS. INST. OF TECHNOLOGY  
ERNEST J. SMITH      SEPT. 1947

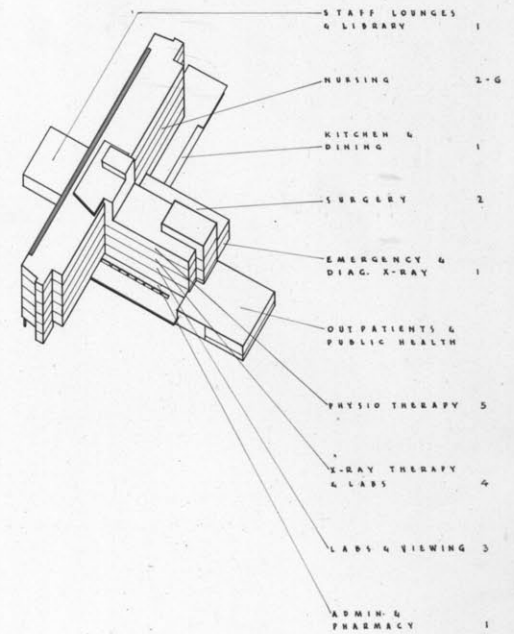
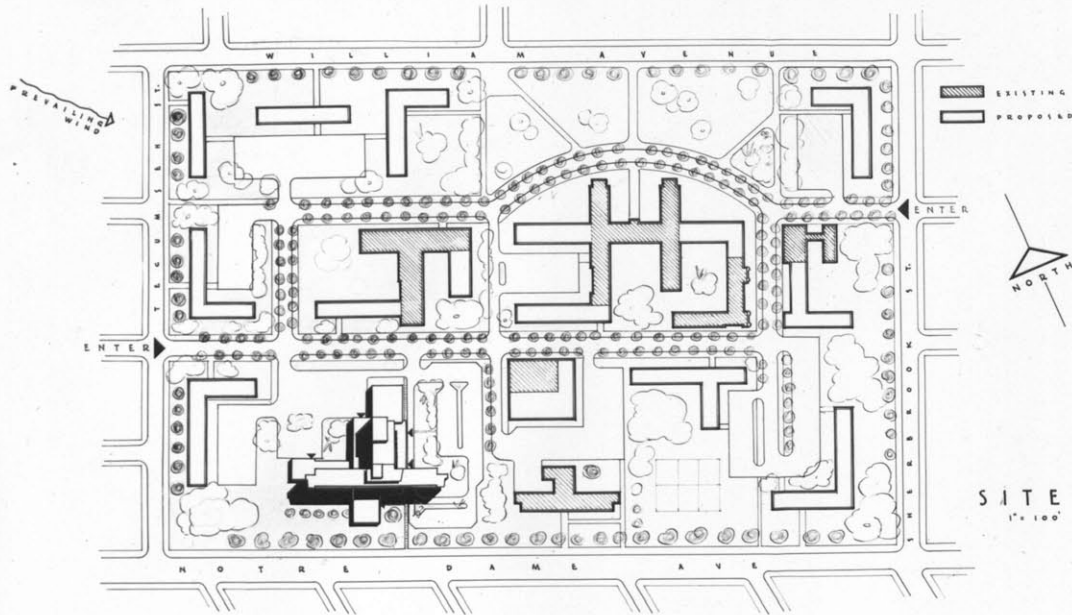

O R G A N I Z A T I O N

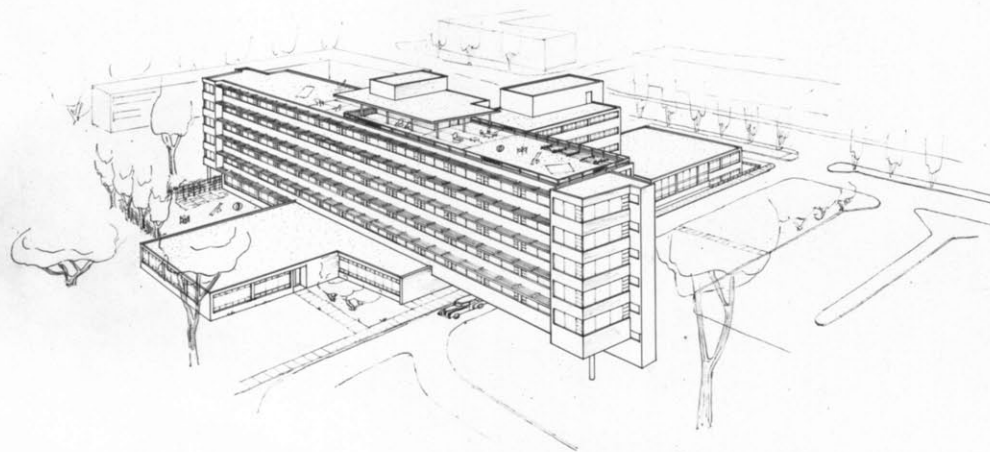

A CHILDREN'S HOSPITAL

THESIS FOR M. ARCH. DEGREE  
 MASS INST. OF TECHNOLOGY  
 ERNEST J. SMITH SEPT. 1947

OUT PATIENT

- 1. WAIT & PLAY
- 2. WAITING RM.
- 3. OFFICE
- 4. IMMUNIZATION
- 5. EXAM. RM.
- 6. OFFICE
- 7. OFFICE
- 8. OFFICE
- 9. OFFICE
- 10. EXAM. RM.

ADMIN.

- 11. OFFICE
- 12. OFFICE
- 13. OFFICE
- 14. OFFICE
- 15. OFFICE
- 16. OFFICE
- 17. OFFICE
- 18. OFFICE
- 19. OFFICE
- 20. OFFICE

PHARMACY

- 21. PHARMACY
- 22. PHARMACY
- 23. PHARMACY

EMERGENCY

- 24. OFFICE
- 25. OFFICE
- 26. OFFICE
- 27. OFFICE
- 28. OFFICE
- 29. OFFICE
- 30. OFFICE

DIAG. X-RAY

- 31. FILM ROOM
- 32. FILM ROOM
- 33. PORTABLE X-RAY
- 34. OFFICE & VIEW
- 35. WAIT
- 36. WAIT
- 37. X-RAY
- 38. X-RAY

KITCHEN

- 39. KITCHEN
- 40. KITCHEN
- 41. KITCHEN
- 42. KITCHEN
- 43. KITCHEN
- 44. KITCHEN
- 45. KITCHEN
- 46. KITCHEN
- 47. KITCHEN
- 48. KITCHEN

DINING

- 49. DINING
- 50. DINING
- 51. DINING
- 52. DINING
- 53. DINING
- 54. DINING
- 55. DINING

SERVICE

- 56. SERVICE
- 57. SERVICE
- 58. SERVICE
- 59. SERVICE
- 60. SERVICE
- 61. SERVICE
- 62. SERVICE

ADMITTING

- 63. ADMITTING
- 64. ADMITTING
- 65. ADMITTING
- 66. ADMITTING
- 67. ADMITTING
- 68. ADMITTING
- 69. ADMITTING

STAFF FACILITIES

- 70. STAFF FACILITIES
- 71. STAFF FACILITIES
- 72. STAFF FACILITIES
- 73. STAFF FACILITIES
- 74. STAFF FACILITIES
- 75. STAFF FACILITIES
- 76. STAFF FACILITIES
- 77. STAFF FACILITIES
- 78. STAFF FACILITIES
- 79. STAFF FACILITIES

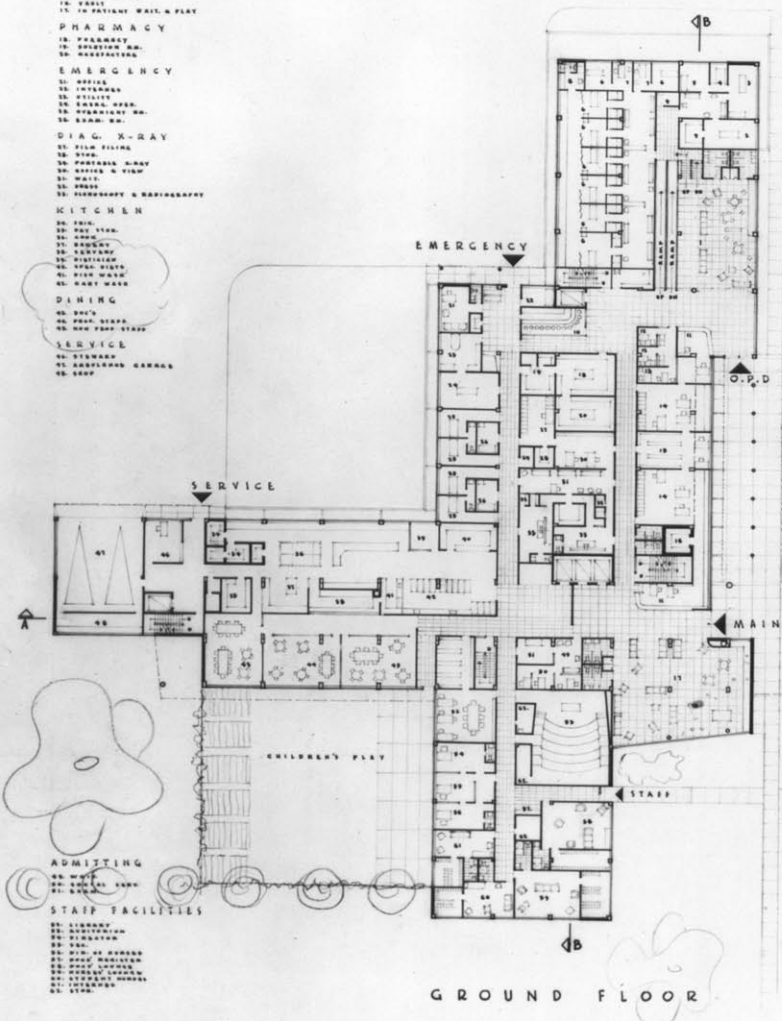

GROUND FLOOR

1" = 16'-0"

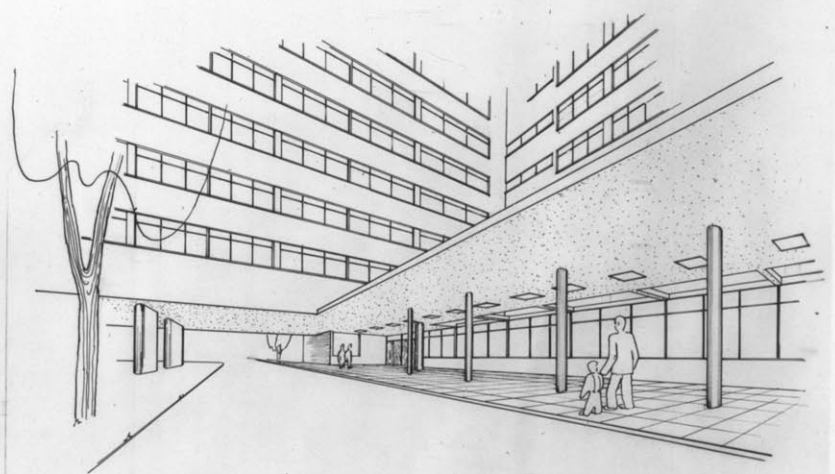

A CHILDREN'S HOSPITAL

THESIS FOR M. ARCH. DEGREE  
 MASS. INST. OF TECHNOLOGY  
 ERNEST J. SMITH SEPT. 1947

**SURGERY**

- 1. ADMITTANCE
- 2. OPERATING ROOM
- 3. CLEAN UP
- 4. INSTRUMENT ROOM
- 5. NURSING LOCKERS
- 6. NURSE LOCKERS
- 7. ANESTHESIA
- 8. FLUENT SIGN
- 9. FLECTOR RM.
- 10. RECOVERY RM.
- 11. RECOVERY
- 12. RM. RM.
- 13. CATER RM.
- 14. STERILE SIGN
- 15. LAUNDRY SUPPLY
- 16. MAJOR OFFICE
- 17. STERILE UP
- 18. STERILE
- 19. STERILE SUPPLY
- 20. HYDRO OFFICE

**NURSING**

- 21. LINDEN H. CORPUS
- 22. DIGN WASH
- 23. MIT
- 24. ATTITUDE
- 25. TOWER
- 26. TOWER
- 27. LEB
- 28. NEW RM.
- 29. NEW PRIC. RM.
- 30. NEW V. RM.
- 31. D. RM.
- 32. W. RM.
- 33. W. RM.
- 34. W. RM.
- 35. W. RM.
- 36. W. RM.
- 37. W. RM.
- 38. W. RM.
- 39. W. RM.
- 40. W. RM.
- 41. W. RM.
- 42. W. RM.
- 43. W. RM.
- 44. W. RM.
- 45. W. RM.
- 46. W. RM.
- 47. W. RM.
- 48. W. RM.
- 49. W. RM.
- 50. W. RM.
- 51. W. RM.
- 52. W. RM.
- 53. W. RM.
- 54. W. RM.
- 55. W. RM.
- 56. W. RM.
- 57. W. RM.
- 58. W. RM.
- 59. W. RM.
- 60. W. RM.
- 61. W. RM.
- 62. W. RM.
- 63. W. RM.
- 64. W. RM.
- 65. W. RM.
- 66. W. RM.
- 67. W. RM.
- 68. W. RM.
- 69. W. RM.
- 70. W. RM.
- 71. W. RM.
- 72. W. RM.
- 73. W. RM.
- 74. W. RM.
- 75. W. RM.
- 76. W. RM.
- 77. W. RM.
- 78. W. RM.
- 79. W. RM.
- 80. W. RM.
- 81. W. RM.
- 82. W. RM.
- 83. W. RM.
- 84. W. RM.
- 85. W. RM.
- 86. W. RM.
- 87. W. RM.
- 88. W. RM.
- 89. W. RM.
- 90. W. RM.
- 91. W. RM.
- 92. W. RM.
- 93. W. RM.
- 94. W. RM.
- 95. W. RM.
- 96. W. RM.
- 97. W. RM.
- 98. W. RM.
- 99. W. RM.
- 100. W. RM.

INFANTS (0-1 YRS)  
44 BEDS

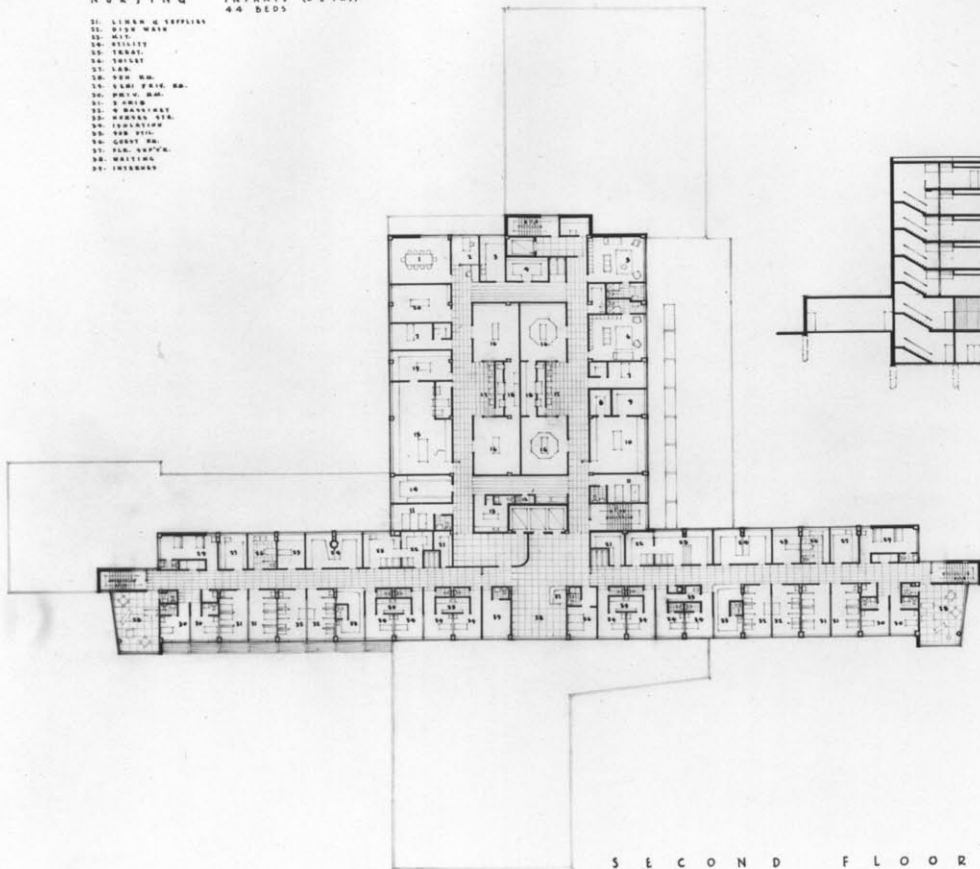

S E C O N D F L O O R 1" = 16'-0"

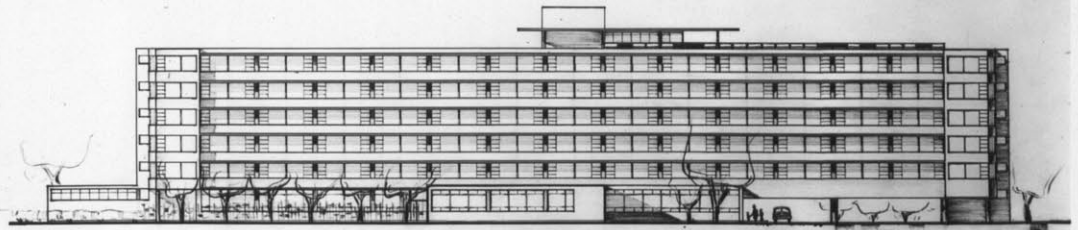

S O U T H E L L E V A T I O N

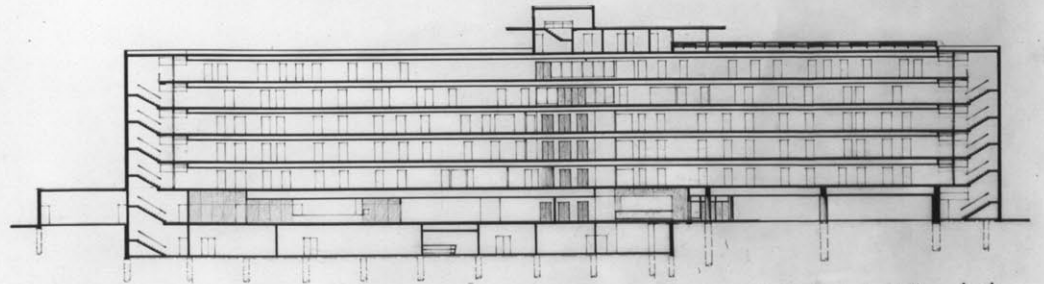

S E C T I O N A - A

**A CHILDREN'S HOSPITAL**

THESIS FOR M. ARCH. DEGREE  
MASS. INST. OF TECHNOLOGY  
ERNEST J. SMITH SEPT. 1947



- VIEWING**
- 1. VIEWING RM.
  - 2. INTERVIEW ROOMS
- LABORATORIES**
- 3. CLINICAL LAB.
  - 4. BLOOD, B.M.R. & SPECIMEN
  - 5. BACTERIA
  - 6. CHEM. LAB.
  - 7. WASH. & STERIL.
  - 8. X-RAY
- NURSING 1-6 YR. OLDS**  
42 BEDS
- 9. LINEN & SUPPLY
  - 10. NURS. WARD
  - 11. NUR.
  - 12. STERILITY
  - 13. TREATY
  - 14. TUBS
  - 15. LAB. RM.
  - 16. LAB. RM.
  - 17. PRIVATE RM.
  - 18. TREAT. ROOM RM.
  - 19. & NUR. STATION
  - 20. & NUR.
  - 21. NUR. STA.
  - 22. NUR.
  - 23. NUR. STA.
  - 24. NUR. STA.
  - 25. NUR. STA.
  - 26. NUR. STA.
  - 27. INTERVIEW ROOM

- OCCUP. THERAPY**
- 1. OCCUP. THERAPY
  - 2. OCCUP. THERAPY
  - 3. BATH. & REST. ROOM
  - 4. BATH
  - 5. REST.
  - 6. REST.
  - 7. TUBS
  - 8. SPECIALIZED TREAT.
  - 9. CORRIDOR
  - 10. NUR. STATION
- LABORATORIES**
- 11. BACTERIO LAB.
- NURSING 6-12 YR. OLDS**  
41 BEDS
- 12. LINEN & SUPPLY
  - 13. NURS. WARD
  - 14. NUR.
  - 15. STERILITY
  - 16. TREATY
  - 17. TUBS
  - 18. LAB.
  - 19. NUR. STATION
  - 20. PRIVATE RM.
  - 21. NUR. STA.
  - 22. & NUR. WARD
  - 23. & NUR. WARD
  - 24. NUR. STA.
  - 25. NUR. STA.
  - 26. NUR. STA.
  - 27. NUR. STA.
  - 28. NUR. STA.
  - 29. NUR. STA.
  - 30. NUR. STA.
  - 31. INTERVIEW RM.

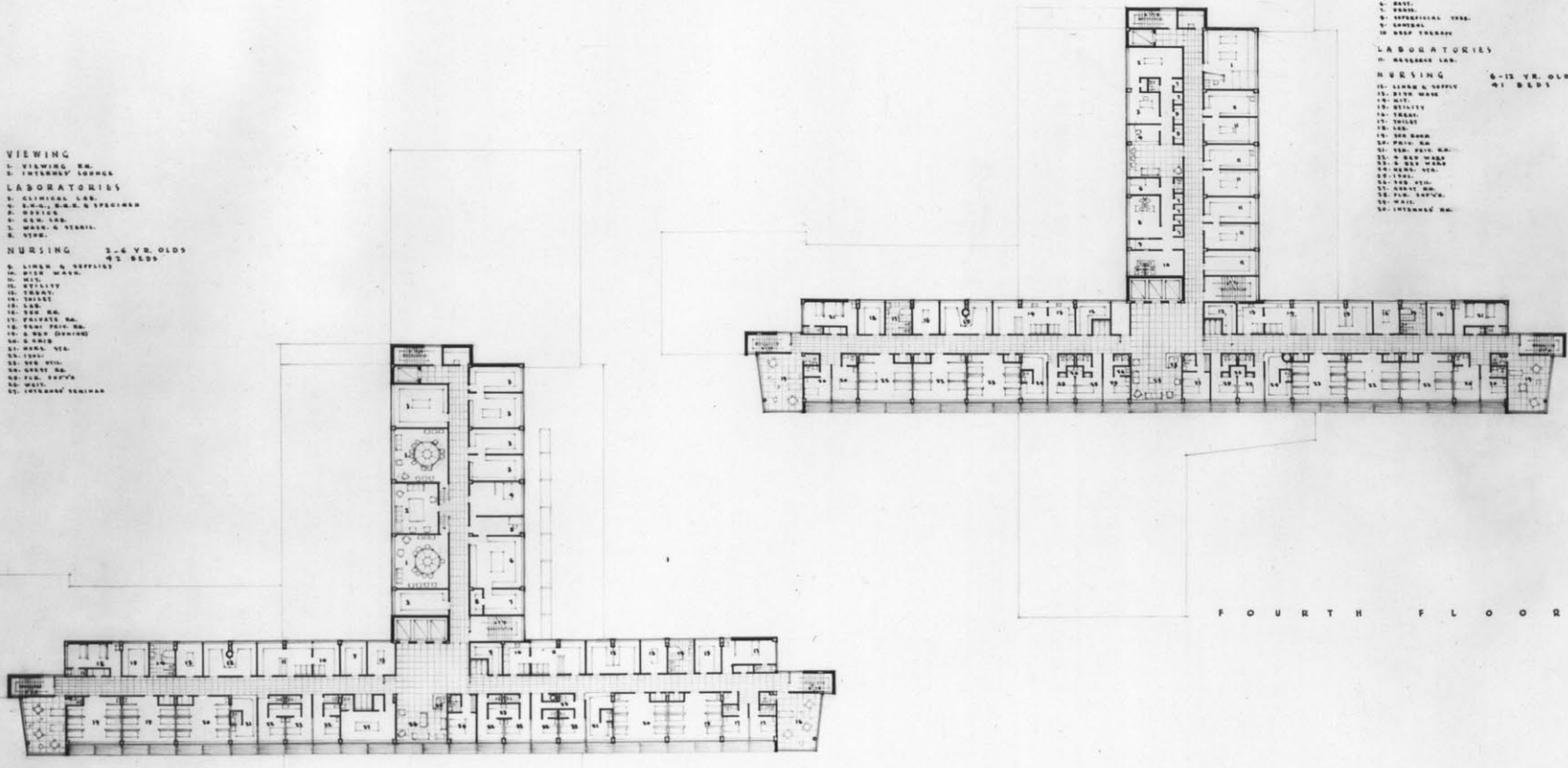

F O U R T H F L O O R

T H I R D F L O O R 1" = 16'-0"

A CHILDREN'S HOSPITAL

THESIS FOR M. ARCH. DEGREE  
MASS. INST. OF TECHNOLOGY  
ERNEST J. SMITH SEPT. 1947

HYDRO THERAPY

- 1. MASSAGE POOL
- 2. SHOWER
- 3. OFFICE
- 4. HYDRO THERAPY (WATER)

ELECTRO THERAPY

- 5. SHOWER
- 6. TREATMENT ROOM
- 7. OFFICE

EXERCISE

- 8. GYMNASIUM ROOM
- 9. OFFICE

NURSING ADOLESCENTS  
36 BEDS

- 10. LAB
- 11. OFFICE
- 12. OFFICE
- 13. OFFICE
- 14. OFFICE
- 15. OFFICE
- 16. OFFICE
- 17. OFFICE
- 18. OFFICE
- 19. OFFICE
- 20. OFFICE
- 21. OFFICE
- 22. OFFICE
- 23. OFFICE
- 24. OFFICE
- 25. OFFICE
- 26. OFFICE
- 27. OFFICE
- 28. OFFICE
- 29. OFFICE
- 30. OFFICE
- 31. OFFICE
- 32. OFFICE
- 33. OFFICE
- 34. OFFICE
- 35. OFFICE
- 36. OFFICE

- 1. BATH ROOM
- 2. OFFICE
- 3. OFFICE
- 4. OFFICE
- 5. OFFICE
- 6. OFFICE
- 7. OFFICE
- 8. OFFICE
- 9. OFFICE
- 10. OFFICE
- 11. OFFICE
- 12. OFFICE
- 13. OFFICE
- 14. OFFICE
- 15. OFFICE
- 16. OFFICE
- 17. OFFICE
- 18. OFFICE
- 19. OFFICE
- 20. OFFICE
- 21. OFFICE
- 22. OFFICE
- 23. OFFICE
- 24. OFFICE
- 25. OFFICE
- 26. OFFICE
- 27. OFFICE
- 28. OFFICE
- 29. OFFICE
- 30. OFFICE
- 31. OFFICE
- 32. OFFICE
- 33. OFFICE
- 34. OFFICE
- 35. OFFICE
- 36. OFFICE

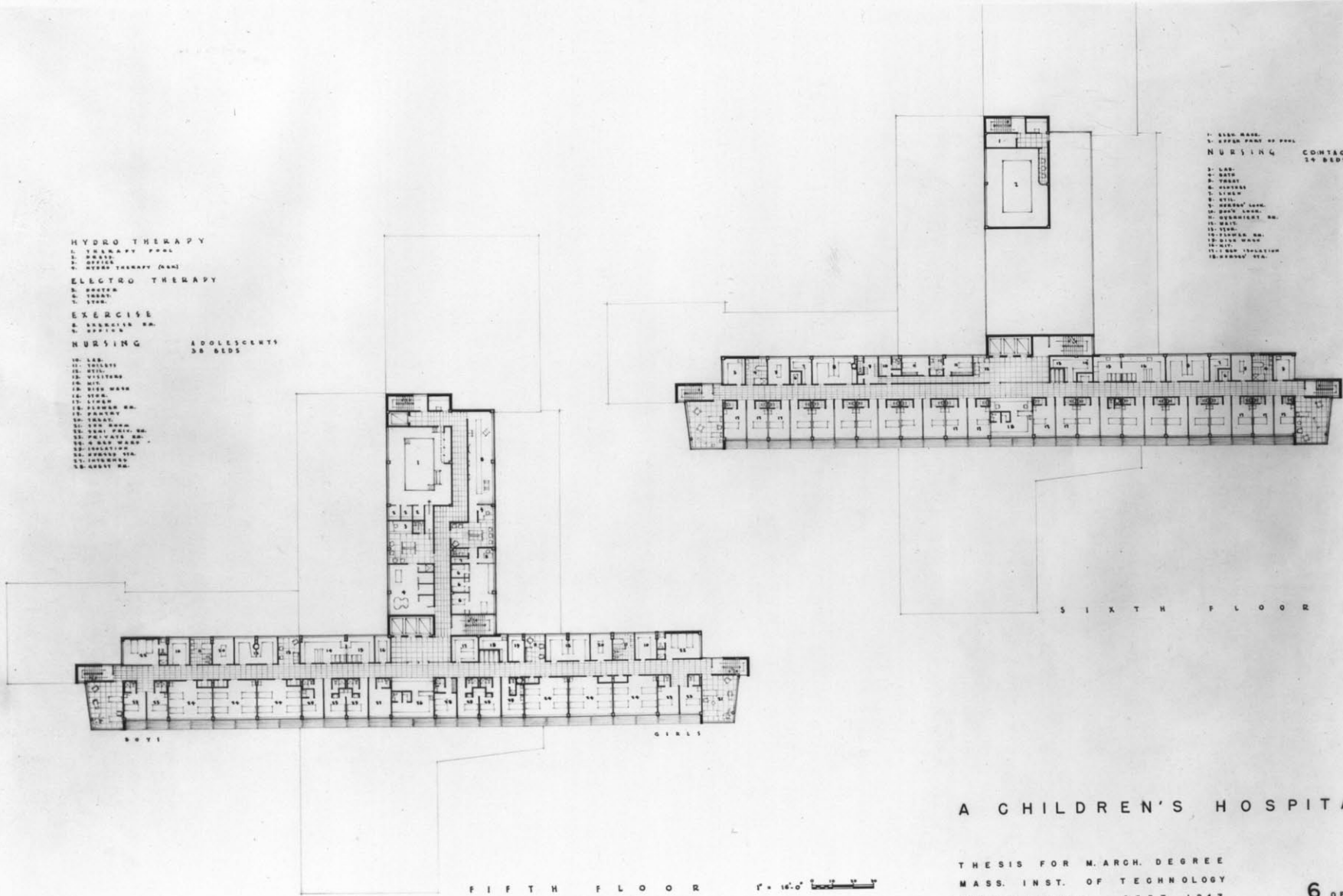

A CHILDREN'S HOSPITAL

THESIS FOR M. ARCH. DEGREE  
MASS. INST. OF TECHNOLOGY  
ERNEST J. SMITH SEPT. 1947

- OUTPATIENT
- 1. WAIT
- 2. X-RAY EXAM.
- 3. DRUG DISP.
- 4. NURSING
- 5. DENTAL EXAM.
- PUBLIC HEALTH
- 6. WAIT
- 7. EXAM.
- 8. INTERVIEW
- 9. BRASS
- 10. OFFICE
- MORQUE
- 11. MORQUE
- 12. BATH
- 13. ANATOMY
- LAUNDRY
- 14. SWISS STAIR
- 15. CENTRAL STAIR
- 16. RECEPTION
- SERVICE
- 17. WOMEN'S LOCKER
- 18. MEN'S LOCKER
- 19. MEN'S TOILET
- 20. MEN'S TOILET
- 21. MEN'S TOILET
- 22. MAINTENANCE SHOP
- 23. BATH
- 24. FURN. STOR.
- 25. HOUSEHOLD STOR.
- 26. GENERAL STOR.
- 27. CARP. STOR.
- 28. STOR.

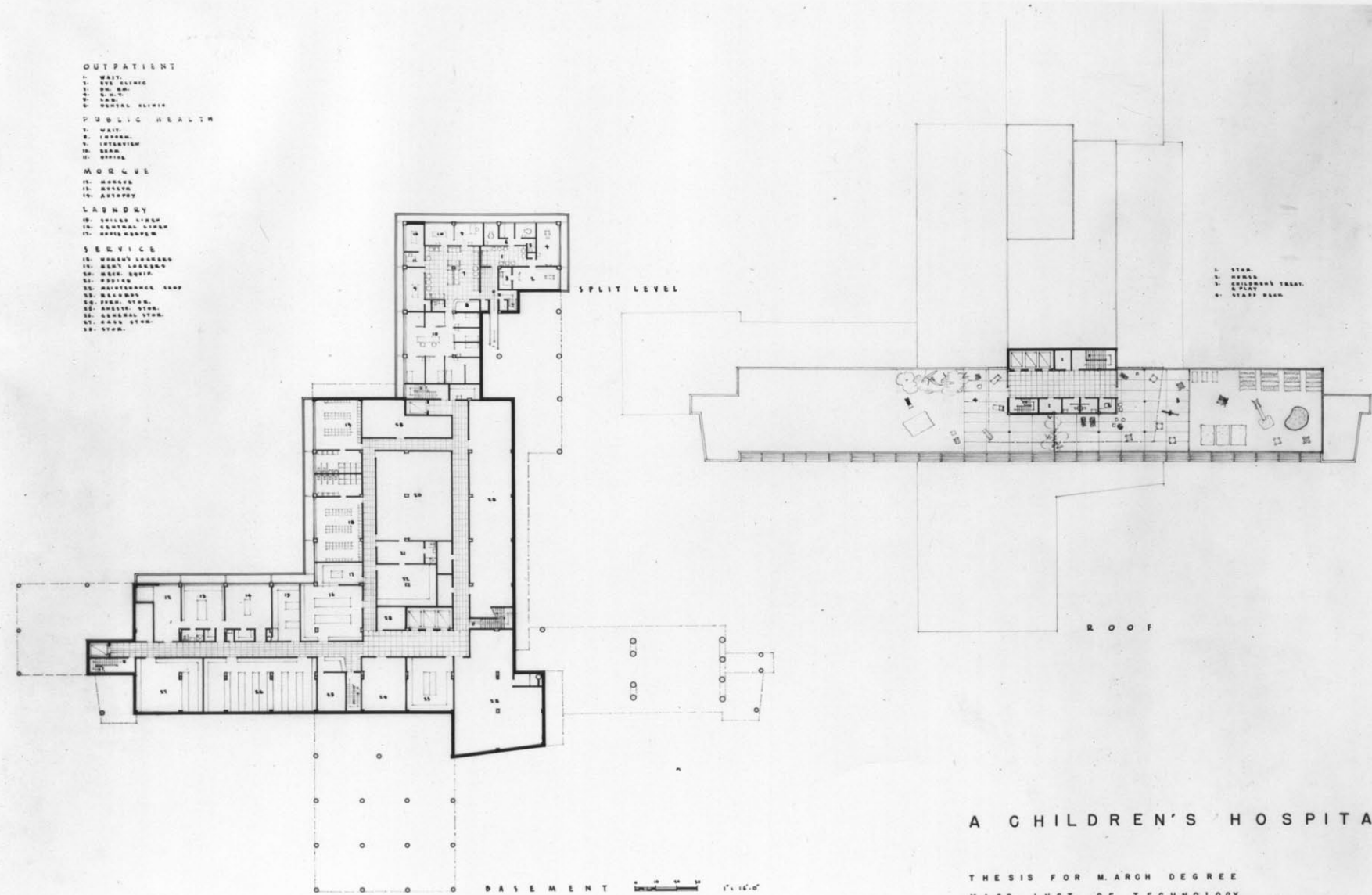

- 1. STOR.
- 2. OFFICE
- 3. CHILDREN'S TREAT.
- 4. STAFF REAR.

A CHILDREN'S HOSPITAL

THESIS FOR M. ARCH DEGREE  
 MASS. INST. OF TECHNOLOGY  
 ERNEST J SMITH SEPT. 1947

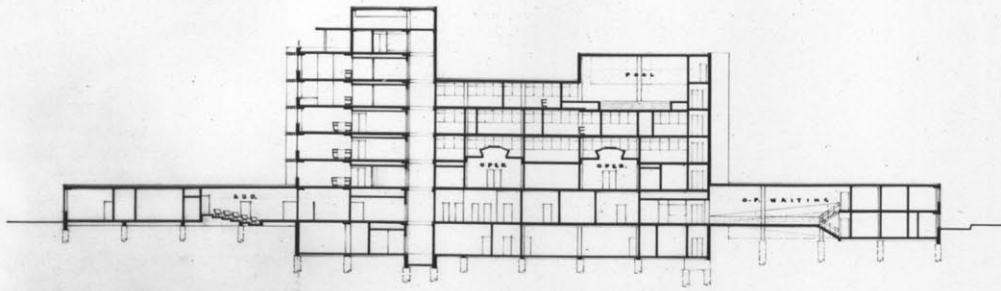

S E C T I O N D - D

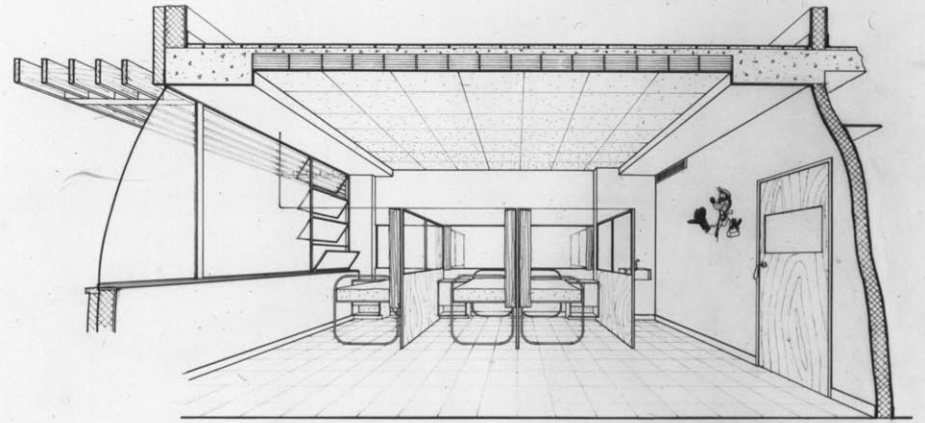

T Y P I C A L W A R D

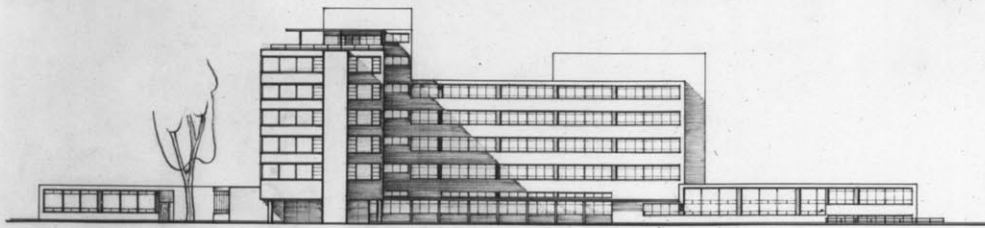

E A S T E L E V A T I O N

1"=16'-0"

A CHILDREN'S HOSPITAL

THESIS FOR M. ARCH. DEGREE  
 MASS. INST. OF TECHNOLOGY  
 ERNEST J. SMITH SEPT. 1947

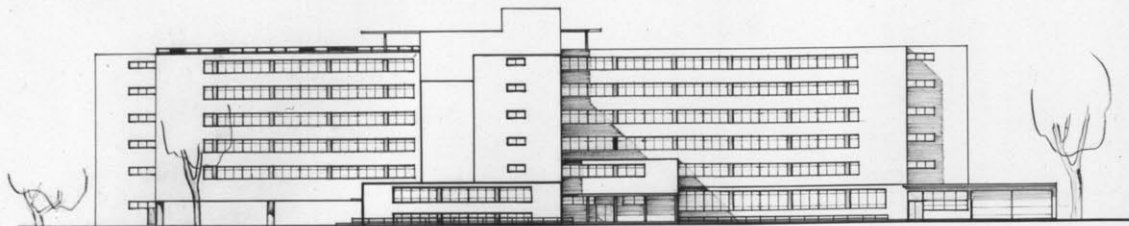

N O R T H E L E V A T I O N

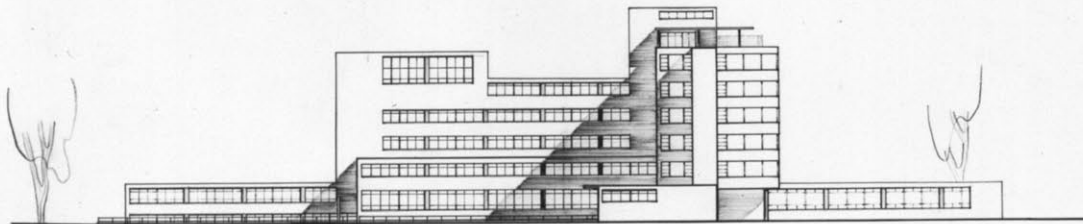

W E S T E L E V A T I O N

1" = 16'-0"

A CHILDREN'S HOSPITAL

THESIS FOR M. ARCH. DEGREE  
MASS. INST. OF TECHNOLOGY  
ERNEST J. SMITH SEPT. 1947

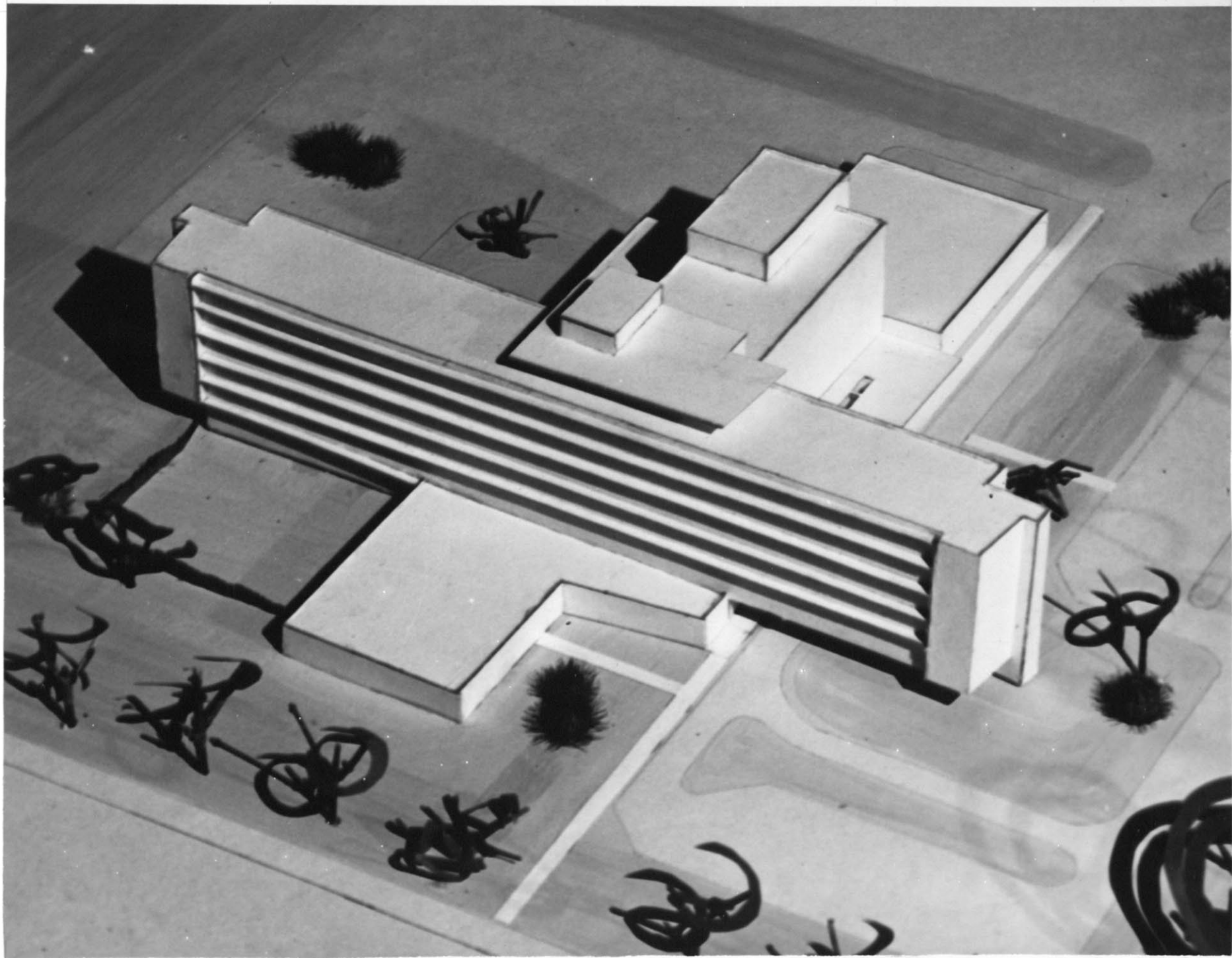

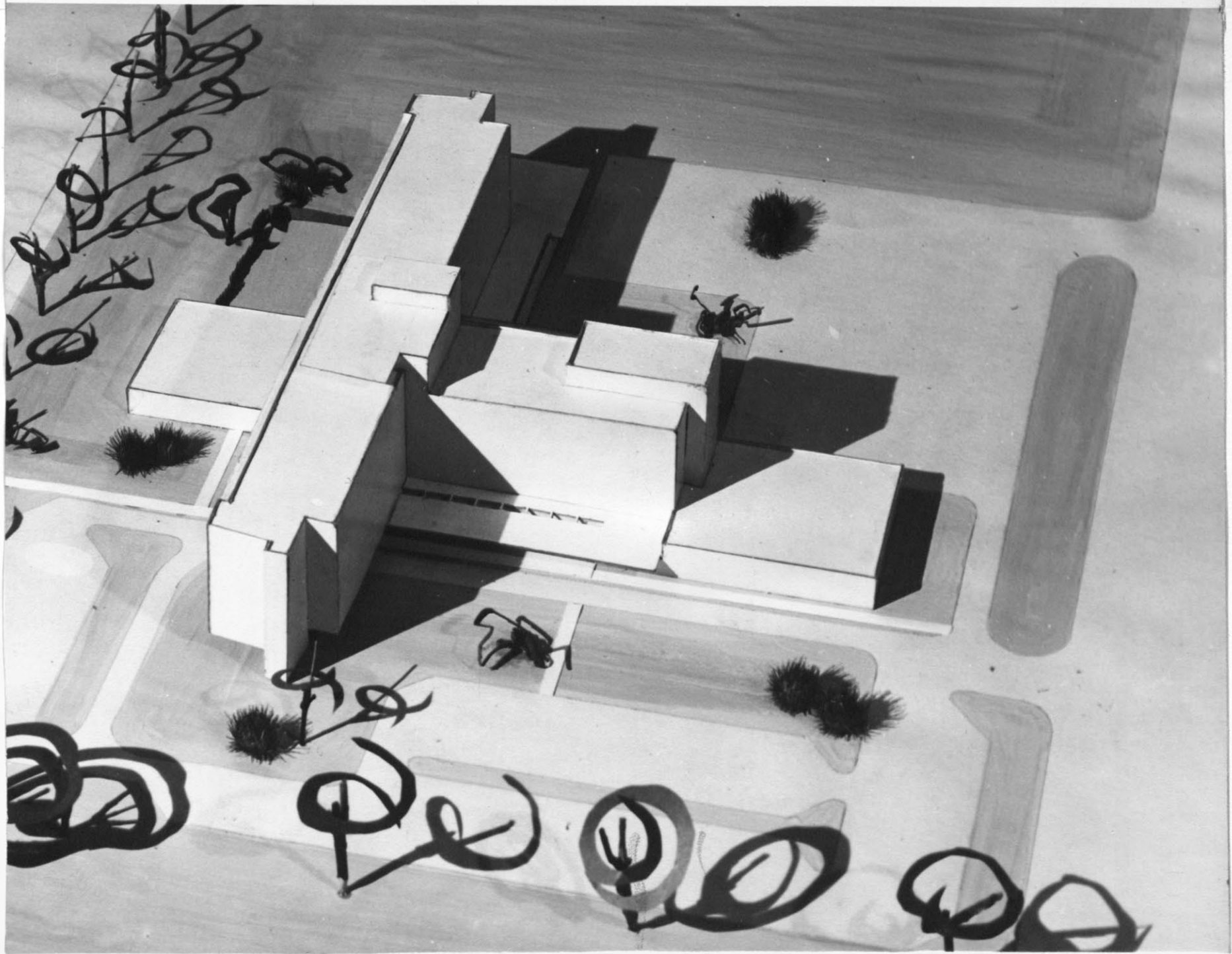

## B I B L I O G R A P H Y

## BOOKS

Butler, Charles and Erdman, Addison: "Hospital Planning."  
New York, F. W. Dodge Corp. 1946. 8-

Dodson, John Milton and Schmidt, Richard Ernest: "Hospitals  
for Infants and Children." Philadelphia and London,  
W. B. Saunders Company, 1926.

Emerson, Charles, D.: "A Preliminary Report Concerning the  
Construction of Hospitals for Children." Baltimore,  
The Friedenwald Company. 1906.

Rosenfield, Isadore: "Hospitals, Integrated Design."  
New York, Reinhold Publishing Corp. 1947.

Stevens, Edward, F: "American Hospital of the Twentieth  
Century." New York, F. W. Dodge Corp. 1928.



## MAGAZINES, PAMPHLETS AND REPORTS.

American Hospital Association: "Measuring the Community for a Hospital." 1945.

Architectural Forum: Hospital Number PP. 387-482 Nov. 1932.

Architectural Forum: Children's Hospital, Denver, Colorado. December 1936.

Architectural Record: Hospital Design and Equipment; Health Centers PP. 374-450 June 1935.

Architectural Record: Mexico City Children's Hospital October 1941.

Bain, Dr. Katherine: (U.S. Dept. Of Labor) Report on "A Children's Medical Center Serving the New England Area." 1944.

Bajpai, Durga Shankos,, "New Delhi Medical Centen." M. I. T. 1946 B. Arch. Thesis.

Fosness, A. W. M.E.I.C. "Foundations in the Winnipeg District." Revised, Nov. 1932. University of Manitoba, Book Department.

Progressive Architecture: "Daylighting for Hospitals" Reprint from Progressive Architecture, December 1945, February and March 1946.

Spencer, Steven M: "We're Taking Better Care of Children Now." Saturday Evening Post P. 32, July 12, 1947.

The Children's Hospital, Boston: (pamphlet) "A Child is not a Little Man." April 1946.

The Children's Hospital, Winnipeg: Thirty-Seventh Annual Report. December 31st, 1945.

U. S. Public Health: Building Types Study No. 104. Architectural Record, August 1945.