

THE CLASSIFICATION AND ANALYSIS OF TERRACE HOUSES AND THE  
RATIONALIZATION OF THEIR DESIGN PROCESS

By; Gabriel M. Nattel, Bachelor of Architecture and Town Planning,  
The Technion, Israel Institute of Technology, 1976

Submitted in Partial Fulfilment of the Requirements for the Degree of  
Master of Architecture in Advanced Studies at the

MASSACHUSETTS INSTITUTE OF TECHNOLOGY ,September 1979

© Gabriel M. Nattel 1979

Signature of the Author \_\_\_\_\_  
Department of Architecture August 10, 1979

Certified by \_\_\_\_\_  
Eric Dluhosch, Associate Professor of Architecture  
Thesis Supervisor

Accepted by \_\_\_\_\_  
Professor Julian Beinart , Chairman Departmental  
Committee for Graduate Students

**Rotch**  
MASSACHUSETTS INSTITUTE  
OF TECHNOLOGY

NOV 29 1979

LIBRARIES

THE CLASSIFICATION AND ANALYSIS OF TERRACE HOUSES  
AND THE RATIONALIZATION OF THEIR DESIGN PROCESS.

Gabriel M. Nattel

Submitted to the Department of Architecture on August 10, 1979  
in partial fulfillment of the requirements for the degree of  
Master of Architecture in Advanced Studies

ABSTRACT

This study was done in relation to two contextual levels;  
A general level of structural-methodical rationalization  
problems of the planning and design process. This general  
level was related mainly to the building types which respond  
to extreme external conditions (such as topography, climate or  
social economic conditions).

The specific level of terrace houses as an example of bu  
buildings of that kind and their adaptation process and mecha-  
nisms to the external conditions as a rational, systematic  
development process.

The S.A.R. approach serves as a background reference for  
this study. Some proposals were made to adopt the S.A.R design  
methodology in the case of terrace houses.

The 'Morphological Box' method which was developed by  
F.Zwicky for the systematic generation of alternative planning  
solutions was modified and applied in the classification and  
analysis purposes as well as in structuring the planning and  
design process to accomodate different external conditions and  
changing design objectives.

These two systematic approaches were applied in the pro-  
posals for the rationalization of terrace houses.

Thesis Supervisor; Eric Dluhosch, Associate Professor of Architecture.



ACKNOWLEDGMENT

---

I would like to take this opportunity to express my gratitude to my thesis advisor - Professor Eric Dluhosch for the devoted and helpful advising and for the encouraging confidence he had in me and in this study.

I would like to thank Professor N.J. Habraken and Dr. M. Gerszo for their helpful advice and support.

In addition I would like to thank Professor W. Zalewski, Professor S. Vamosi and Professor M. Safdie for their constructive advise.

TABLE OF CONTENTS

---

1.	INTRODUCTION	
1.1.1	definitions-----	7
1.1.2	the relevance of terrace houses -----	8
1.2.1	classification and analysis - the method -----	12
1.2.2	the application of the morphological box -----	16
1.2.3	the notation system of the parameters and variants -----	22
2.	CLASSIFICATION AND ANALYSIS	
2.0	classification- examples -----	23-62
2.1	site condition parameter group - general -----	63
2.2	the slopes and the relation of the building to the----- natural slope	67
2.3	the soil conditions and foundation systems for terrace houses	75
2.4	natural light and ventilation in terrace houses -----	80
2.5	connection to the urban circulation network -----	84
2.6	site boundaries - geometric form and orientation of the site-- boundaries to the slope direction	89
2.7	orientation to the sun direction -----	94
2.8	terrace houses the building types -----	97
3.	ZONING SYSTEM - A PROPOSAL	
3.0	a proposal for a zoning system for terrace houses - general ----	107
3.1	the diagonal zoning system -----	110
3.2	the horizontal zoning system -----	116

3.2.1	the horizontal zoning systems - parallel to the slope -----	117
3.2.2	horizontal zoning systems - segmental (transversal) zoning -----	124
	examples for the application of the proposed zoning systems ---	130-134
4.	THE APPLICATION OF THE MORPHOLOGICAL BOX IN IDENTIFYING AND CONTROL OF THE DESIGN PROCESS	
4.1.1	the structuring list of the planning and design stages -----	136
4.1.2	the selection process -----	137
4.2.1	SEQUENCE No.(1)- -----	138
4.2.2	SEQUENCE No.(2)- -----	151
4.2.3	SEQUENCE No.(3)- -----	165
	examples of application of complete morphological box in the classification -----	179
5.	CONCLUSION -----	184
	bibliography-----	191

1. I N T R O D U C T I O N

1.1.1 DEFINITION :

This work deals with terrace houses which are located on slopes. The slope's angle can vary from 5 to 45 degrees. This definition does not exclude any specific type of terrace houses on slopes, although it emphasizes clusters of dwelling units more than one family, detached houses.

The terrace houses were studied in relation to two main contextual levels;

(a)-The general level; Terrace houses as a specific example of the building types which are generated by extreme external conditions (such as climatic, site topography or social and economical conditions). These extreme conditions generate the adaptation process of the building to the various aspects of its context, resulting in a definition of a distinct building type. The mechanisms of this

adaptation process should be studied on the level of its elements and its overall characteristics, and then generalized to other building types which undergo parallel process development.

(b)-The specific level; This level is specifically practical in terrace houses. In this context the inventory of terrace houses was examined, classified and analyzed. The proposed design tools and the analyses conclusions can be implemented mainly in terrace houses but the method of their formulation can be generalized to similar processes in other building types.

(1.1.2) THE RELEVANCE OF TERRACE HOUSES :

The relevance of terrace houses in today's urban realities should be tested in two contextual levels; the public level and the private housing level.



The urban development in many cities which are located in mountainous or hilly environment show some clear similarities. The development trends in many of these cities were inclined to utilize first the flat sites which were available in the urban area, and only then, if no other choice was at hand, develop houses on the slopes. This approach created a common situation where the ridges of the hills and mountains and the valleys between them, became the prime choice of urban development (or rather exploitation). The obvious results of this development type were primarily the excessive expansion of the urban concentrations over the hills ridges and the valleys, with the increasing segregation of the urban structure which made many urban structure systems either unefficient or even obsolete in some cases. Urban roads networks, infra-structural systems like sewage and water supply as well as electricity systems are stretching to

distances far too long relatively to the population size which they serve.

Because of these reasons the urban growth pattern which emerged can be defined as artificial growth pattern as the area which was urbanized in that way had the capacity to support much larger population (with all the building implications of such larger population).

The assumption that the areas which were urbanized with that type of development can support larger population, is based upon the following assumptions;

(a)-That there is a point along the urban development process (which is concentrated mainly on the hills' or mountains' ridges or in the valleys between them) where public demands of various nature (social, economical, etc.) build up enough pressure to change the present urban development trends.

(b)-That more efficient and rational design and construction methods can yield by their implementation an economical advantageous feasibility to building on the slopes.

(c)-That there is a point in the urban development where the spreading of the urban area reaches so far that sites in the central area, which were unattractive for development before, become economically compatible with remote flat sites.

A conclusion for these assumptions is that along the development process of urban areas in mountainous or hilly environment, occurs a phase beyond which the development of housing and other urban activities on the slopes becomes a rational conclusion of an analysis of the current urban situation in the light of future development needs.

(1.2.1) CLASSIFICATION AND ANALYSIS.

THE METHOD

The first step in the classification and analysis study was to establish the definitions of the terrace house types which will be the focus of this study. The next step was the sorting out of the relevant information on those examples of terrace houses which follow that definition. Information on other types of terrace houses (mainly terrace houses on flat sites and terraced 'super structures') served as reference later in the analysis.

The development of a list of parameters for the classification was the next step in the analysis. The initial parameters list served as a hypothesis of the relevant parameters for the classification of this particular building type. The variants (or 'values') which were assigned to each parameter were identified after the examination of the examples and extracting

those which did not appear on the parameters' list before.

The parameters which were applied in the analysis can be categorized into:

- Programatic parameters; densities, land coverage, environmental protection rules of different nature (such as the building height, possible use of local materials, preservation of some natural qualities etc.). These parameters may also include such parameters as spatial standards for private and public spaces (open and closed) and more.

- Site conditions parameters; The slope's angle, the orientation of the site to the sun and wind, orientation of the site boundaries to the slope direction, connections to the urban circulation networks, soil conditions, etc.

- 14 -

- Design parameters; such as the basic functional patterns inside the dwelling units, ventilation and lighting methods, the relation of the building to the natural sloped site, etc.

- Technical parameters; foundation systems, structural systems, various infrastructural systems of the building, etc.

Once all the examples were studied and classified, the classified information could be analyzed and evaluated. This analysis had two goals; the first was to draw some conclusive information concerning the characteristics of the terrace houses which were designed and built in the past. The second goal of that analysis was to refine the list of parameters into a list of meaningful generic variables which are characteristically applied in terrace houses.

One of the important results of this phase was the generalization of the basic generic functional

settings (or patterns) in the dwelling units by a zoning system for terrace houses. The method of establishment of the zoning system as a design tool was based upon the Dutch zoning system, as described in "Variations; The Systematic Design of Supports". This zoning system had to be slightly modified to accommodate the special needs of the terrace buildings. The proposed zoning system was tested in some of the examples of terrace houses which were classified before and it is assumed that the same zoning system can be applied in the design of other terrace houses.

The next steps in the analysis were in fact a second analytical cycle. Some of the conclusions of the former steps were re-applied in the examples for validation.

The parameters and their generic variables ('values') were put in some hierarchical orders which represented different scenarios of design and constructions of terrace houses. The study of these various 'scenarios' can serve in the rationalization of terrace houses.

(1.2.2) THE APPLICATION OF THE 'MORPHOLOGICAL BOX'

---

This study had been applying to a large extent the 'Morphological Box' method, which was developed by Fritz Zwicky, a swiss born astrophysicist at Cal-Tech. This method is the best known of several methods which were generated by the 'Morphological Approach', developed by Zwicky with the intention "to aid mankind in understanding all interrelations of human life and the universe. The morphological box encourages and even forces the bringing together of previously unrelated concepts, into new and novel combinations".

With that method, the characteristic parameters (or variables) which describe the subject of the study, and their respective variants (the alternative solutions or 'values' which the parameters might assume) are identified and defined. The various parameters and their respective variants are organized in an open end matrix which has rows as the number of parameters with a variable number of variants in each row. All these elements are notated to make this table legible and easy to operate with. Each combination of one variant for each parameter when completed for all the parameters list is representing one



distinctive example of the study subject. Through a process of sorting through the various combinations the 'impossible' combinations can be dropped, and the rest are ready for various evaluations and the selecting process. To make the selecting process easier and more efficient the number of parameters should be kept down to a minimum number of generic parameters which can express the significant differences between the various examples of the study subject.

By introducing some 'rules' concerning the interrelations between the parameters (i.e. hierarchy), the morphological box can be converted into a 'morphological tree', which is a narrower version of the morphological box, as by introducing the hierarchy into the process, a wide range of combinations (or 'morphologies') is eliminated.

The method which was applied in this study can be defined as a hybrid between the morphological box and the morphological tree. The parameters can be arranged in a hierarchical order which can be altered to suit different planning and design objectives. By doing so, the parameters combination possibilities are still larger than with the morphological tree, but can be reasonably managed and manipulated to meet those planning and

design objectives.

When the basic structure of parameters and their respective variants is determined, the relevant information elements from each example of the study can be classified into that structure. Finally, each example can be represented by a list of variants (in codes) which are assigned to it in each parameter. The coding is done according to a notation system which was established with the completion of the parameters and variants lists.

The generic parameters and their respective variants can represent the planning and design decisions which are made throughout every comprehensive design process. The difference between a common design process of making design decision after considering its alternative solutions and, on the other hand the application of the morphological box method, lies in the clarity by which the influence of each decision which is made through the process on the end product, can be easily traced.

The observations which were made during the classification of terrace houses indicated the possibility of the presence of a basic common structure of planning and design of terrace houses, which undergoes some alterations in specific cases.

These alterations are essentially changes in the hierarchy of the decisions on the various design and planning parameters which effected the possible choice of alternative variants for each one of the parameters. With that hypothesis, the hierarchy of the decisions, which is obvious in every planning and design process, can be altered with according changes in the choice possibilities of the alternative variants. The hierarchy of the parameters is allowing those which appear at the top of the list more choice possibilities of 'legitimate' solutions, with the opposite situation occurring with the parameters at the bottom of the list. This is not saying that each parameter is necessarily effecting the choice possibilities in the following parameters. Generally, the possibility of such narrowing of choice range is increasing towards the bottom of the parameters list.

The parameters which are independent of any other parameter on the list are indifferent to their location on the list, and can be located anywhere along it without disrupting the hierarchical order of the other. Their placement can be done according to considerations which are apparently outside the scope of the planning and design objectives of the specific

case. A second consideration should be given in the case of the 'independent parameters' to check again whether they maintain any generic importance or not. If at that point they do not have that generic role, they can be removed from the parameters list and make the sorting out and the selection process with the morphological box more efficient.

The hierarchical parameters can represent a sequential process of planning and design. This sequence of decisions is arranged in a deliberated order, to meet various combinations of design and planning objectives.

The morphological box was applied in the following stages of this study ;

- In the classification and analysis stage the morphological approach was adopted as a classification method. Through the analysis and the classification stage the elements of the morphological box (the parameters and the variants) were identified and organized.
- The same morphological box was applied in building three hypothetic sequences of planning and design decisions (planning and design 'scenarios') which demonst-

rated the application of that approach in structuring various types of planning and design process sequences to meet various combinations of external conditions.

-The morphological box was applied in classifying some examples in the completed form of the morphological box for terrace houses (in a notation ).

The same notation system was applied through all this study. The notation of each parameter group, each parameter and variant is the same from the first classification study through the various analytical steps to the final form of the morphological box for terrace houses.

(1.2.3) THE NOTATION SYSTEM OF THE PARAMETERS AND THE VARIANTS  
OF THE 'MORPHOLOGICAL BOX'.

---

- Each parameter is identified by a letter (a),(b),etc, which is the same through this study.
- Each variant is identified by a number (in addition to the identification of the variant with the parameter (.\_.3),(.\_.5).
- If the variant is a combination variant it is notated by the number which refers to a combination as a variant and then, in brackets, The numbers which identify the combined variants. (example; (8.(2+4+6)) ,).
- In every parameter variants list the last variant is"other", to allow adding new alternatives which were not included in the or-ginal list.
- The affiliation of each parameter with a larger parameter group is notated by a respective capital letter in the upper horizontal line (only in the complete table).

**(2.0) CLASSIFICATION EXAMPLES**

---

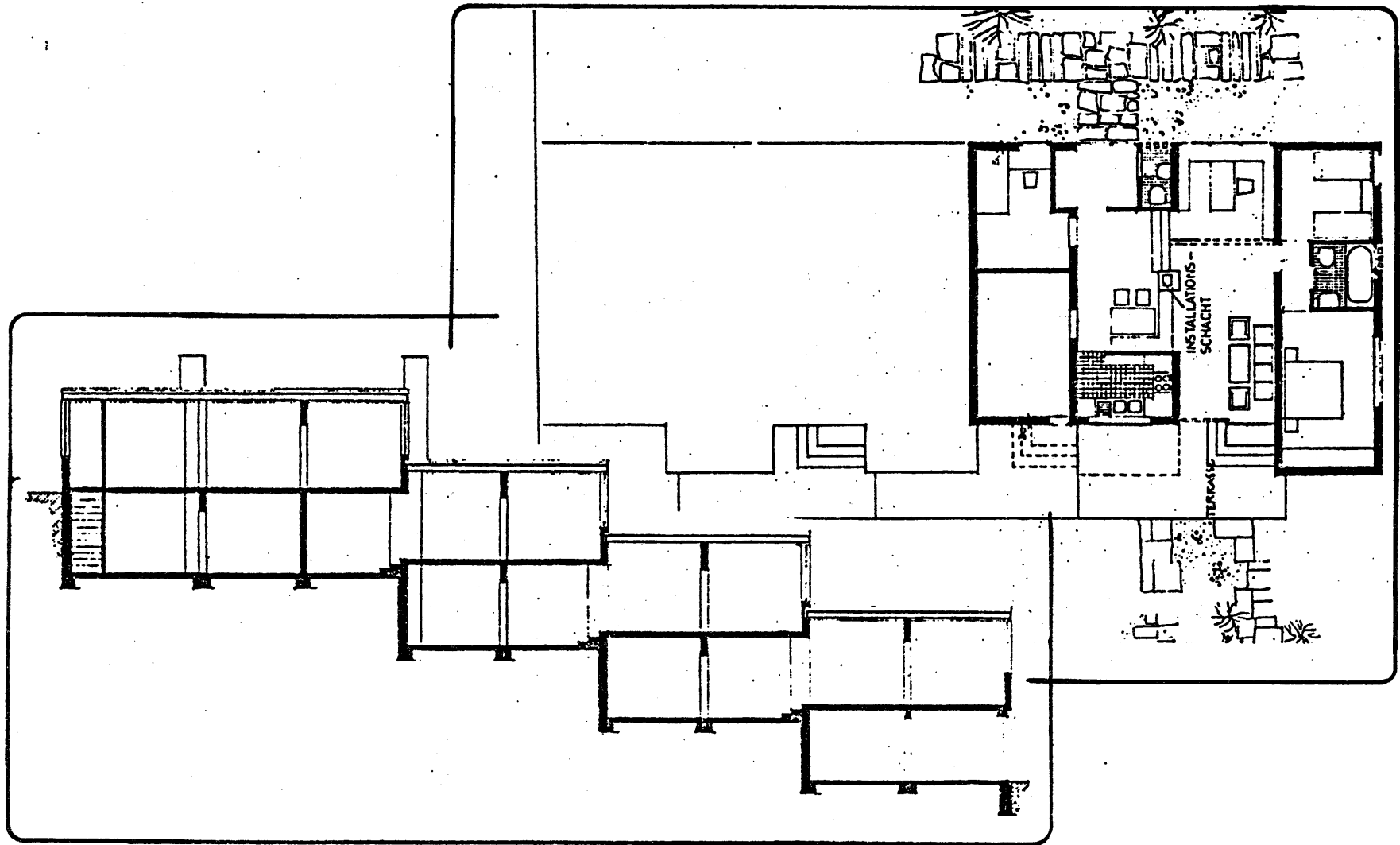

Project ; Starnberg Germany

Architect ; H.Peter Buddeberg.

1



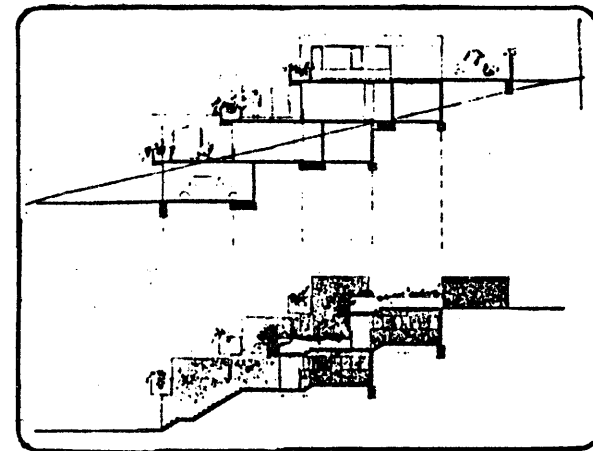
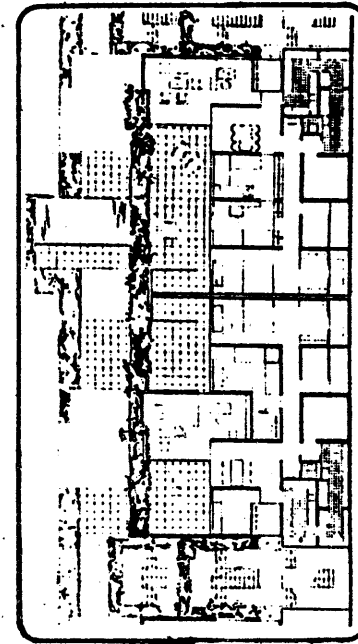
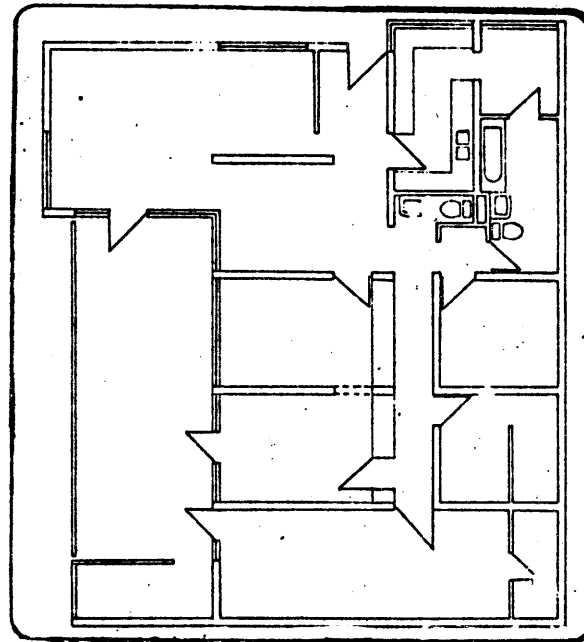

---

**Project ;** Heidelberg-Boxberg

**Architect ;** J.Herkommer, Alscher, Berger, Kiesewetter, Otto

**2**

---

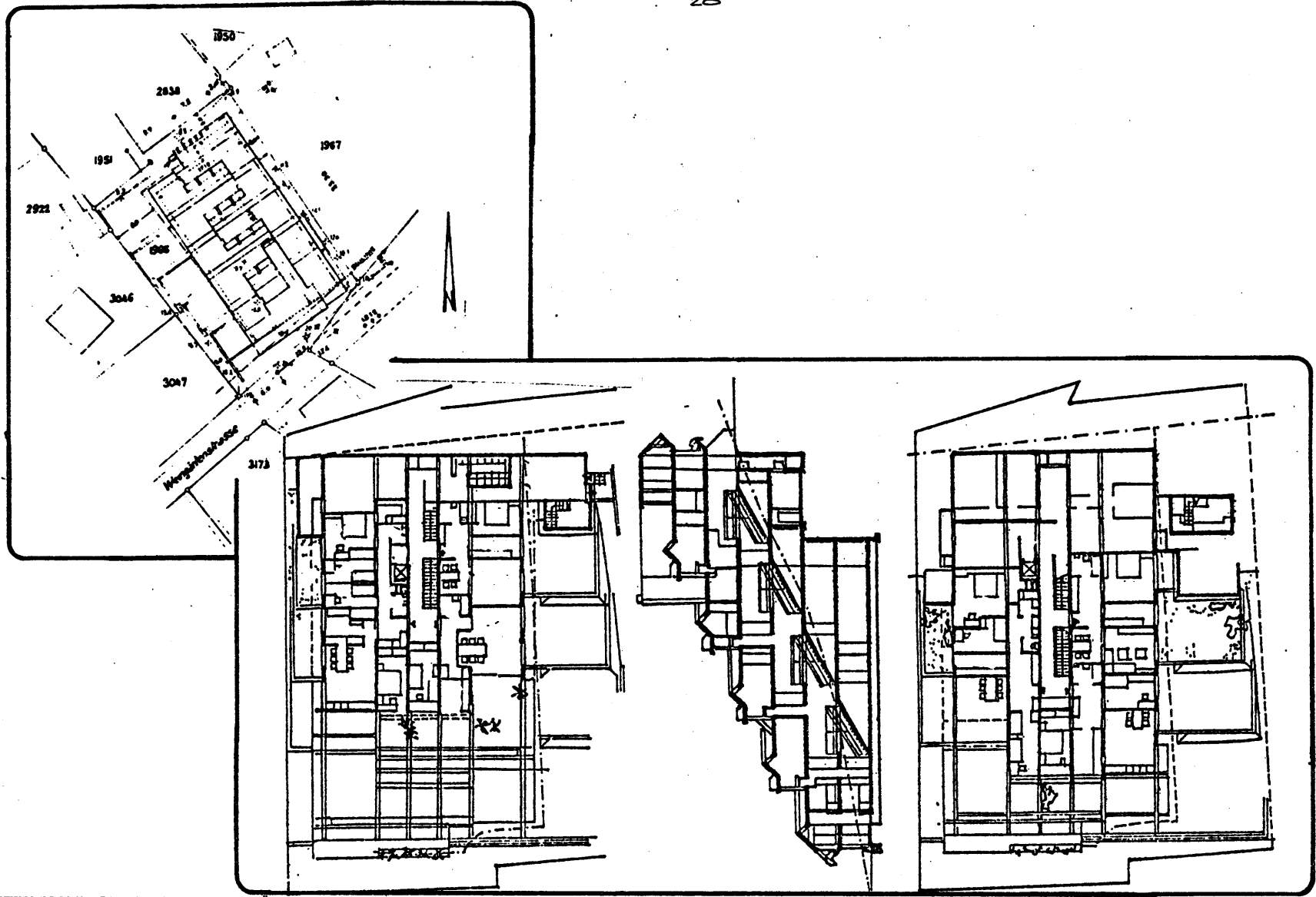

Project ; Visp Suisse

Architect ; André M. Studer

**3**

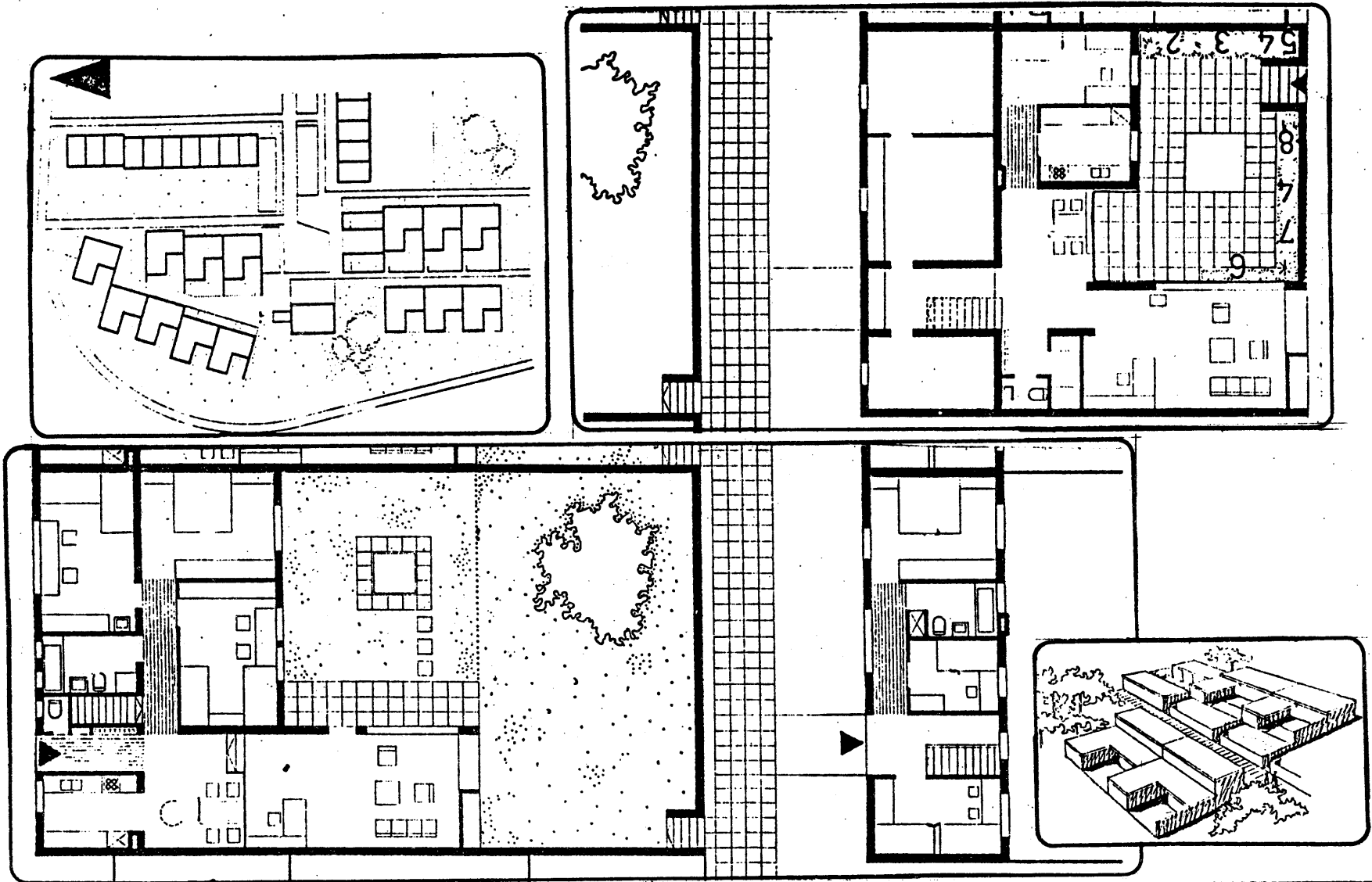

Project; Maria-Hof, Trier  
Architect; Klaus Frey

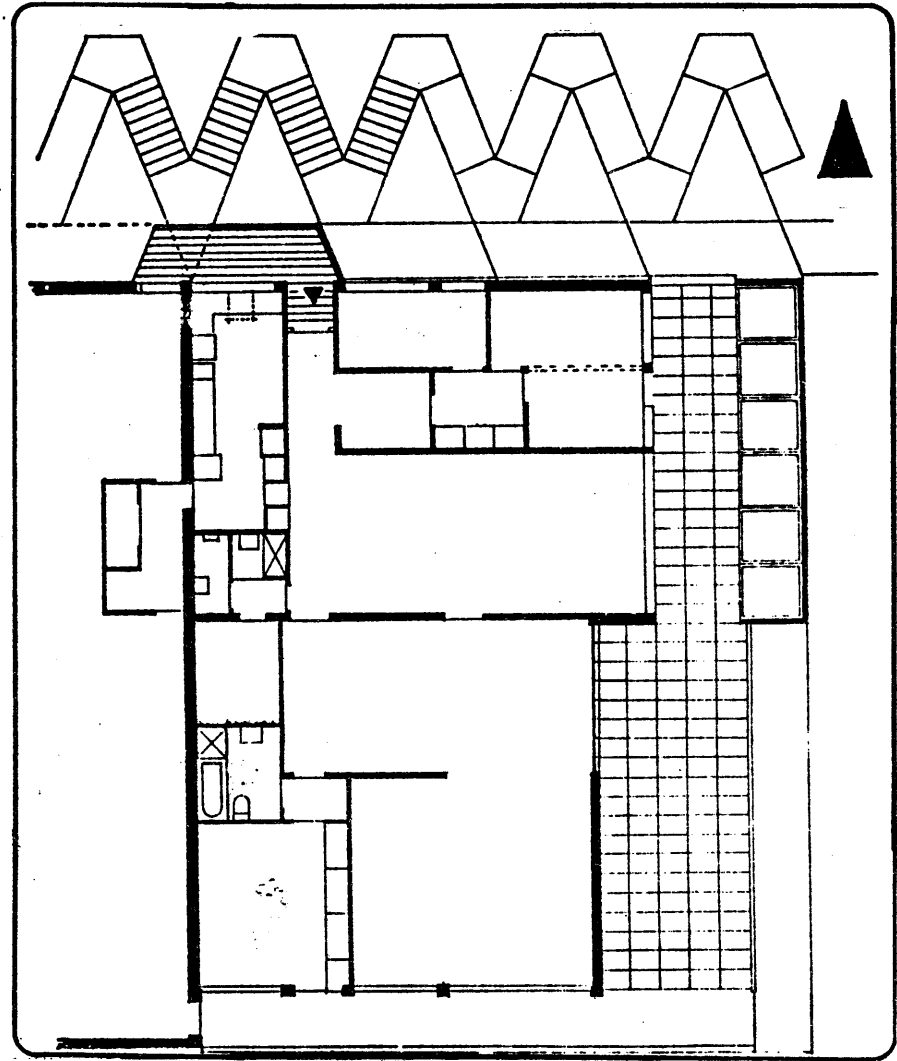
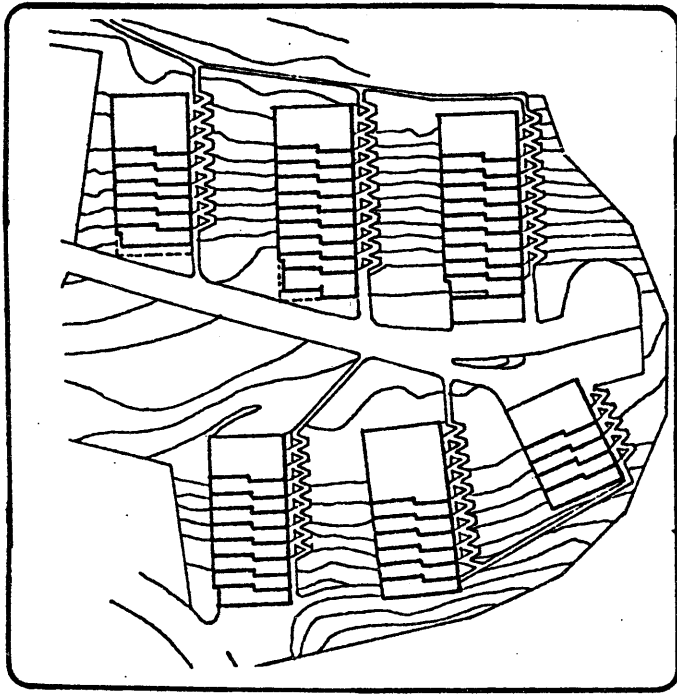
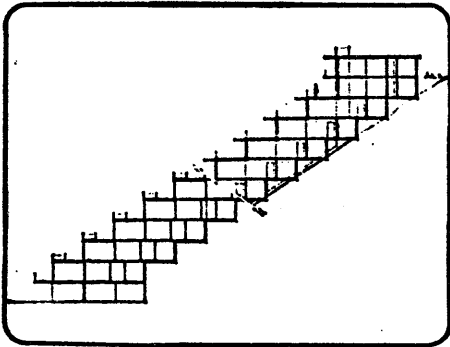

Project; Ullernaasen Oslo

Architect; Anne-Tinne & Mogens Friis

5

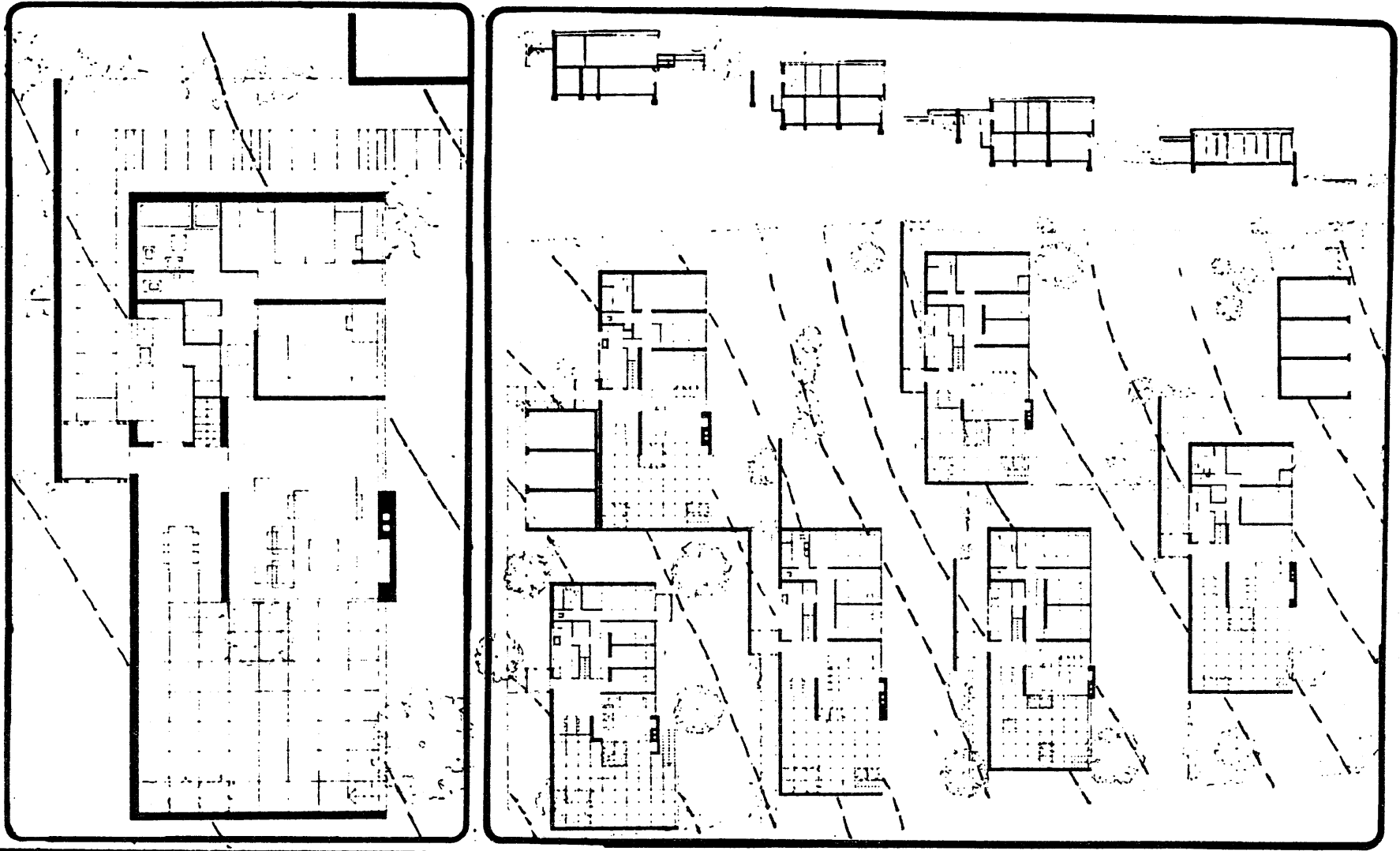

Project; Rossdorf, Germany

Architect; Gerhard Heid

6

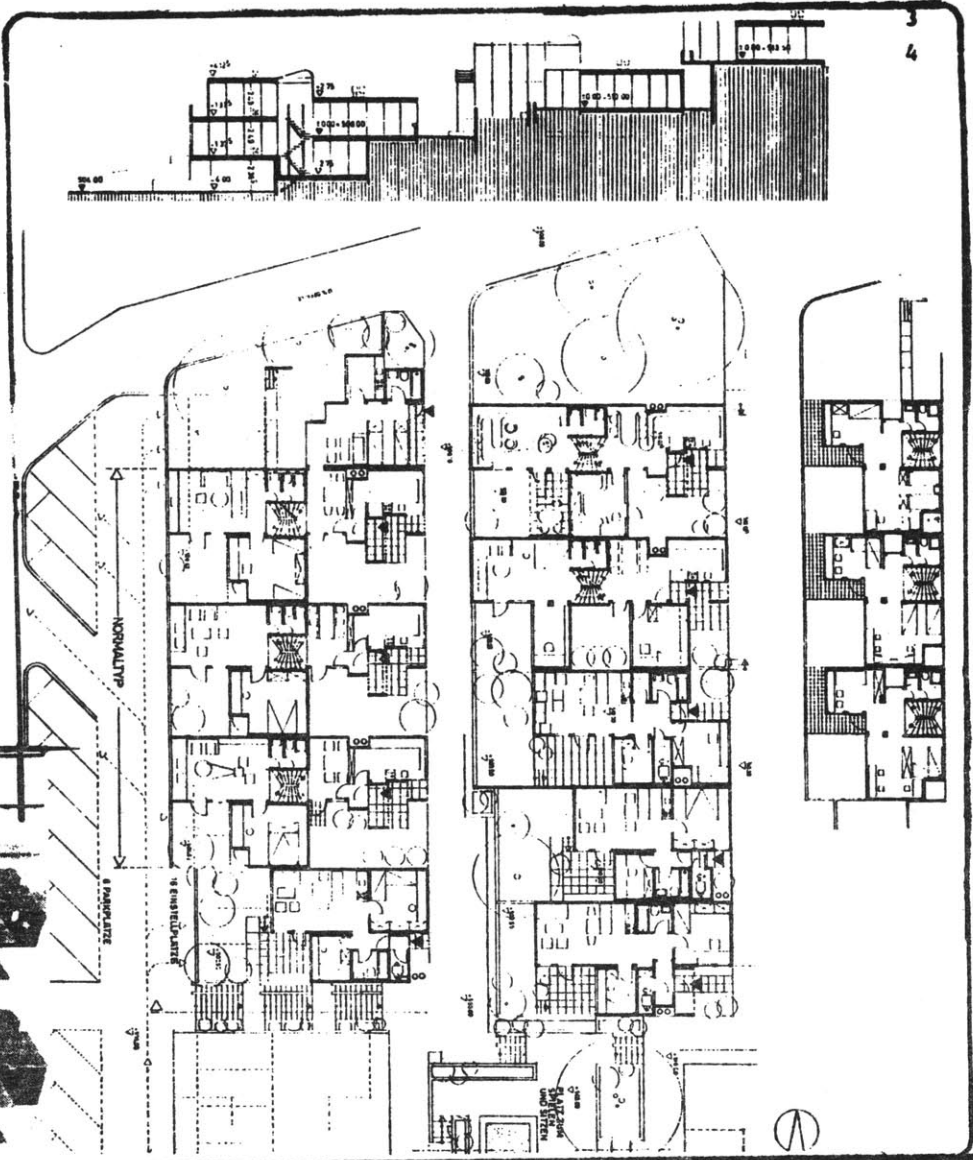
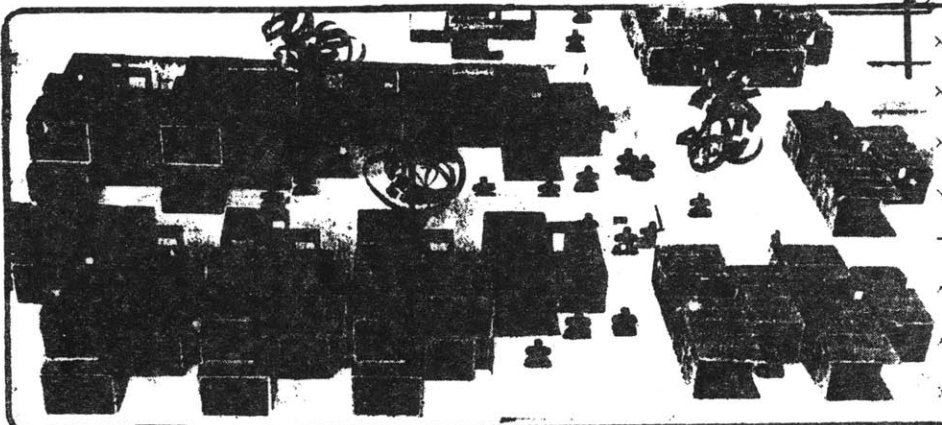
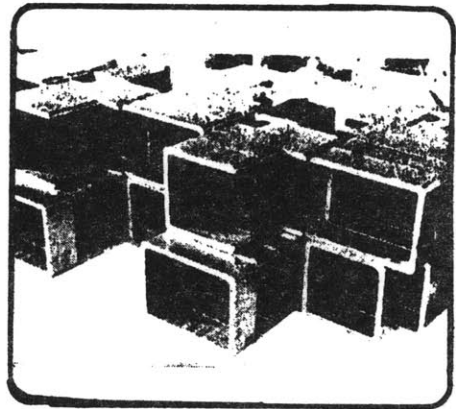

Project; Balzers Liechtenstein  
Architect; Ot Hoffmann

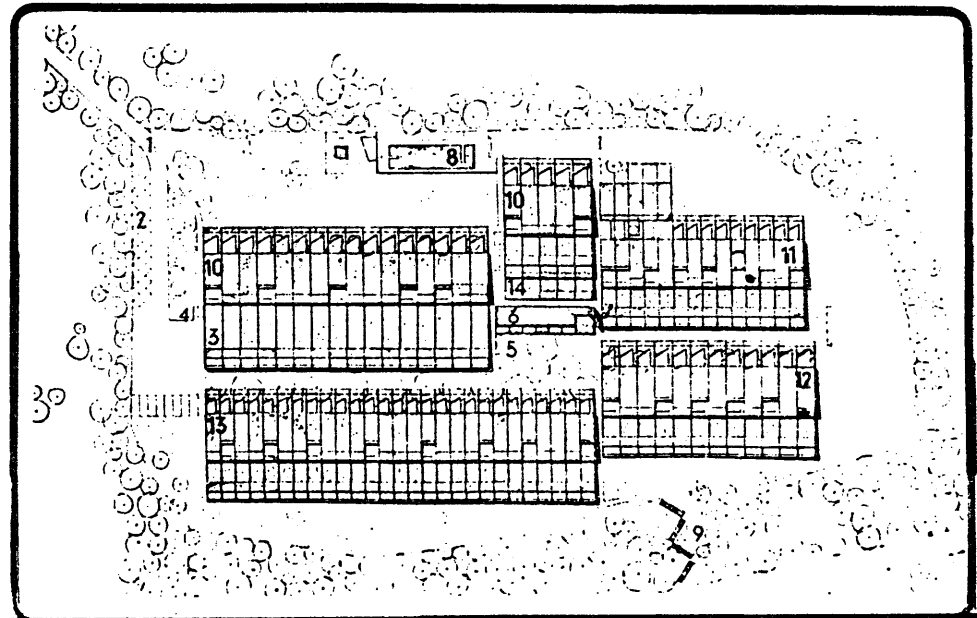

Project; Siedlung Halen bei Bern Swisse

Architect; Atelier 5

8

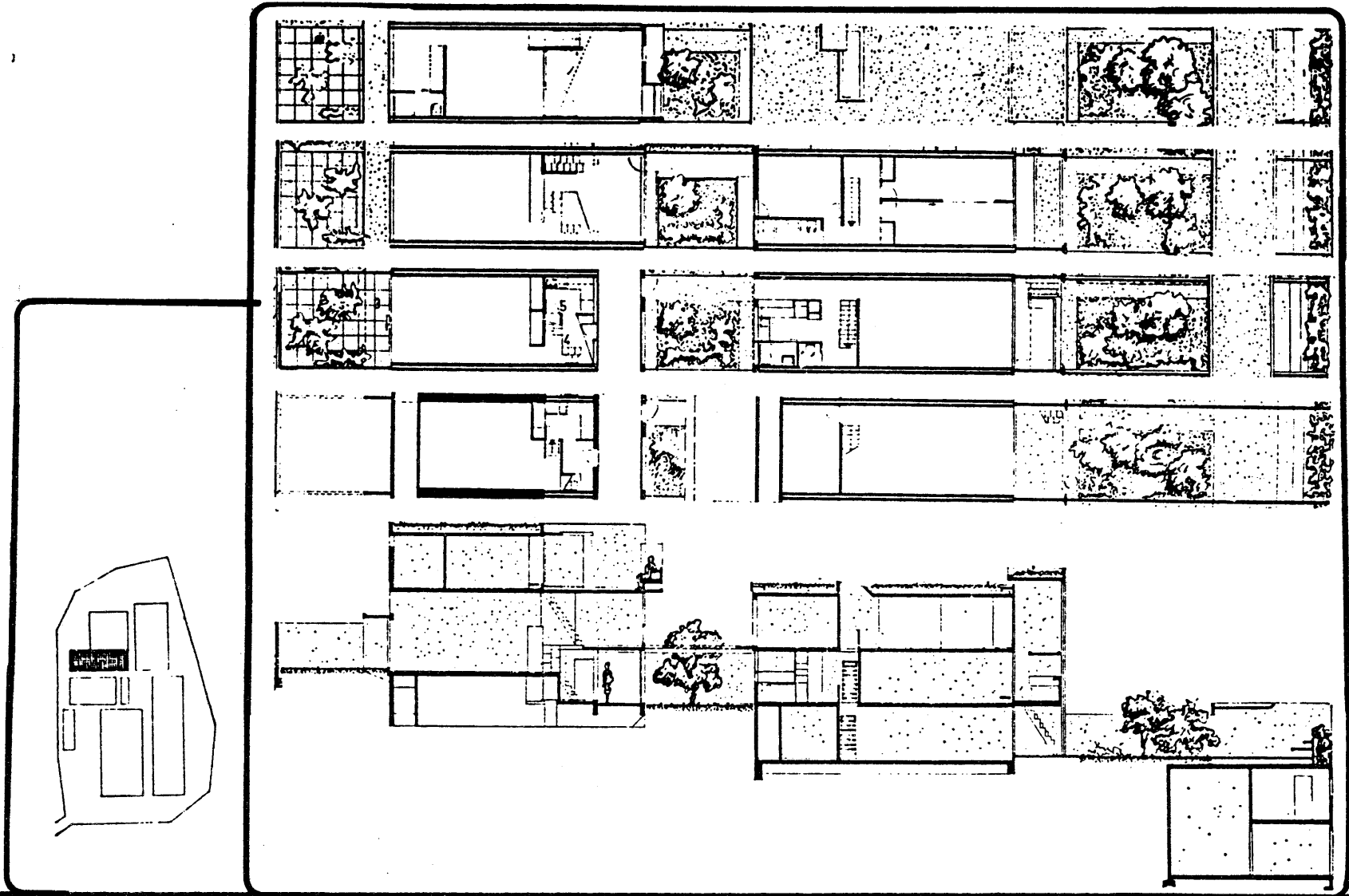

Project; Siedlung Halen bei Bern Suisse

Architect; Atelier 5

8



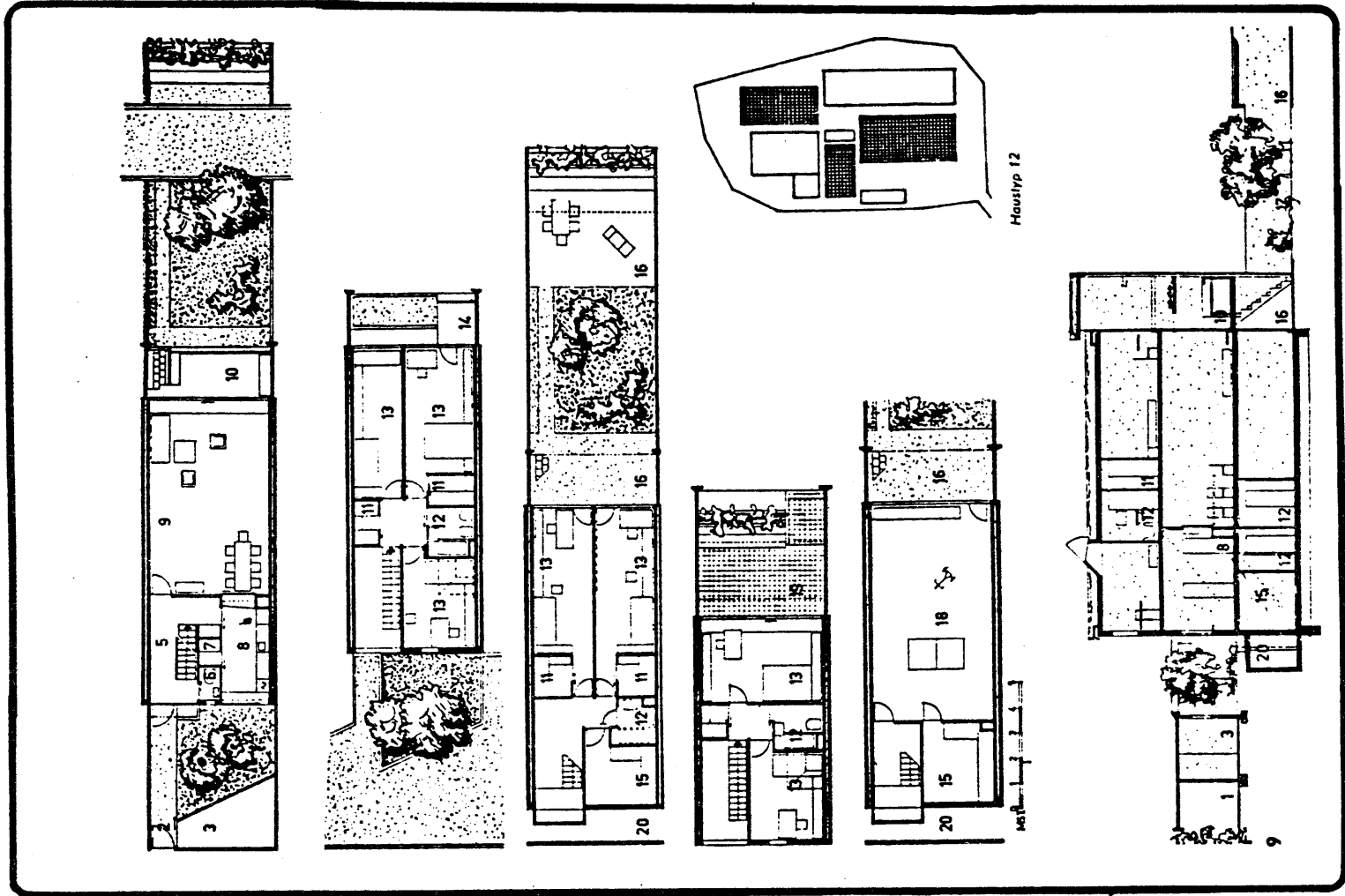

Project; Siedlung Halen bei Bern Swisse  
Architect; Atelier 5

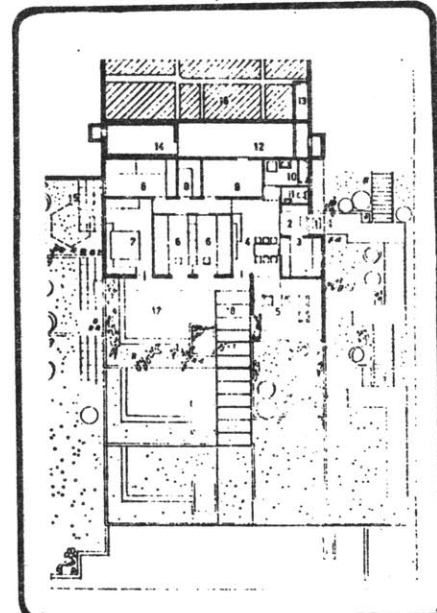
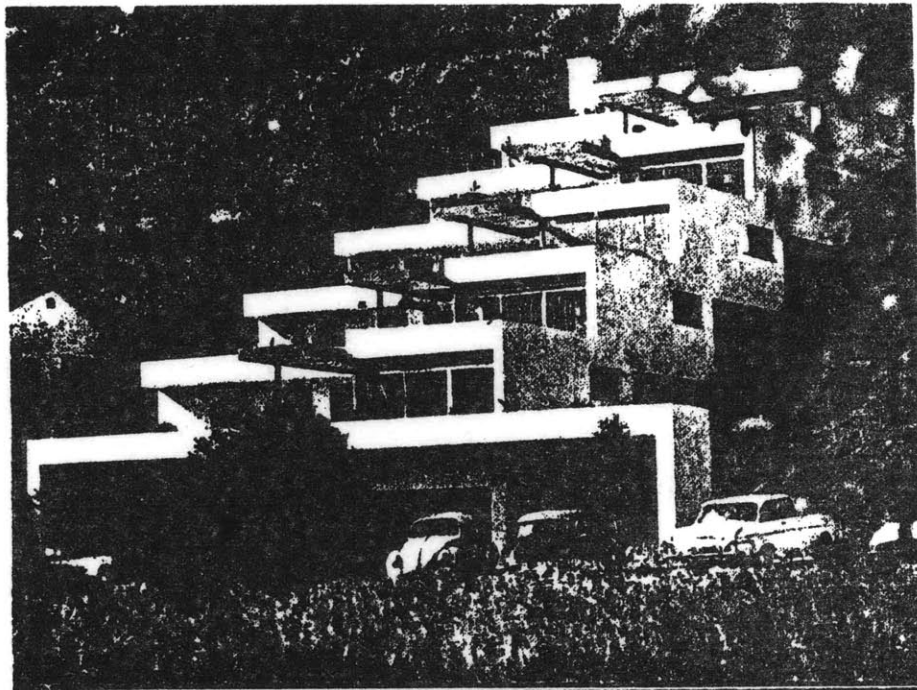
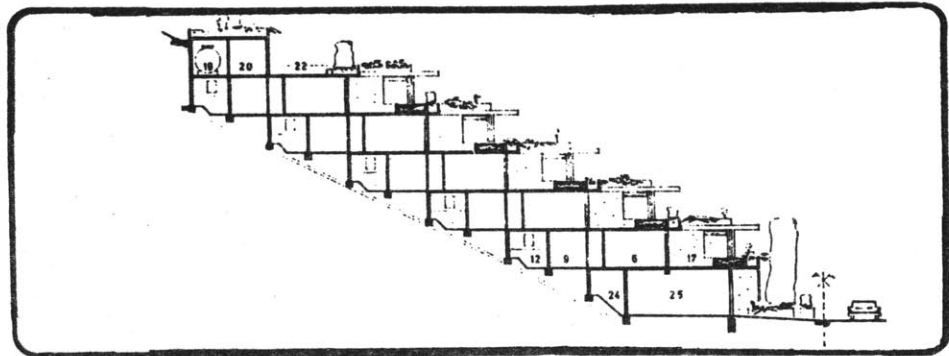

**Project ;** Pfaffenzien Untersiggenthal Suisse

**Architect ;** Robert Frei

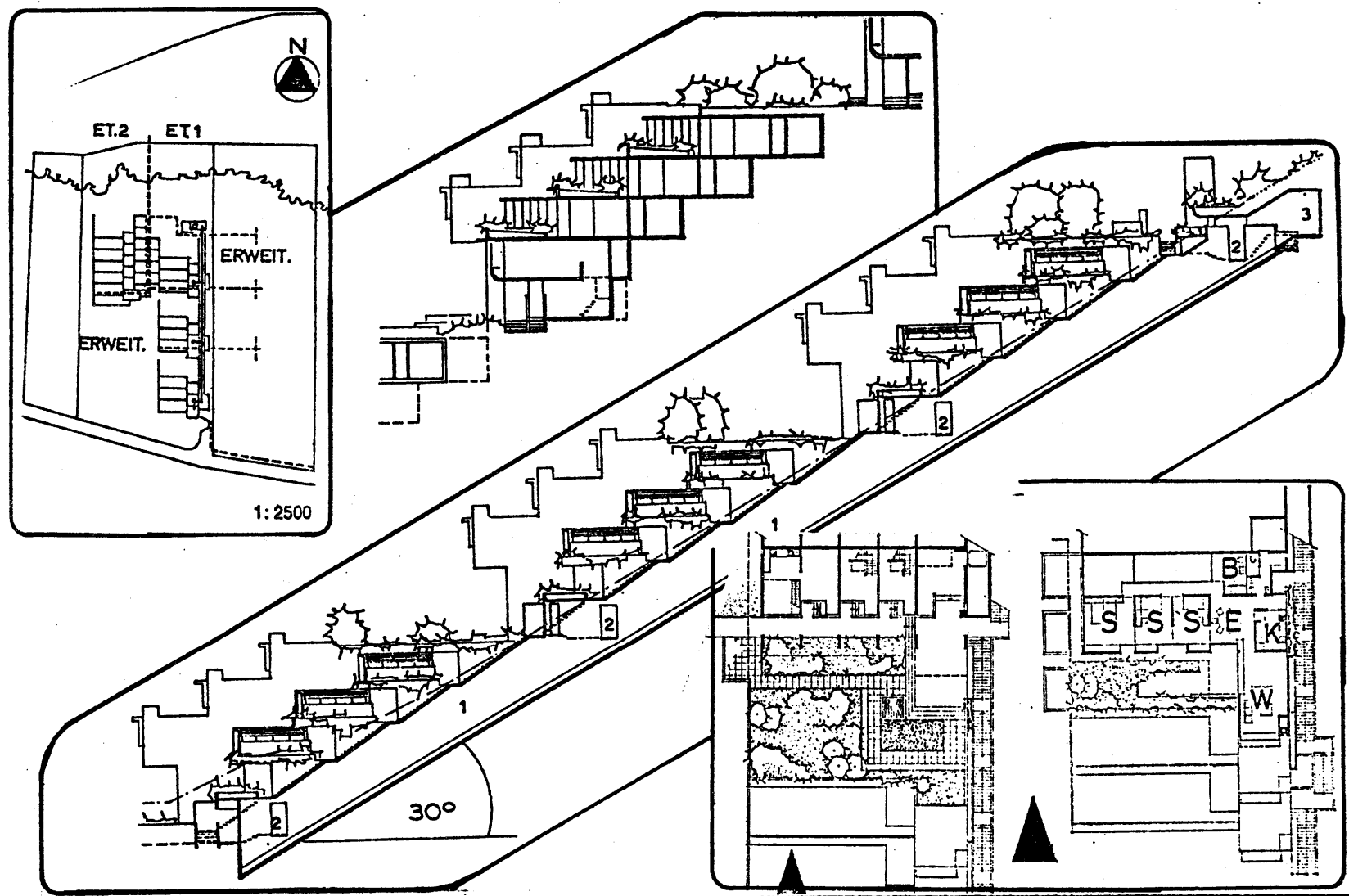

Project ; Mühlehalde, Brugg Swisse

Architect ; Team 2000. Scherer, Strickler, Weber

10

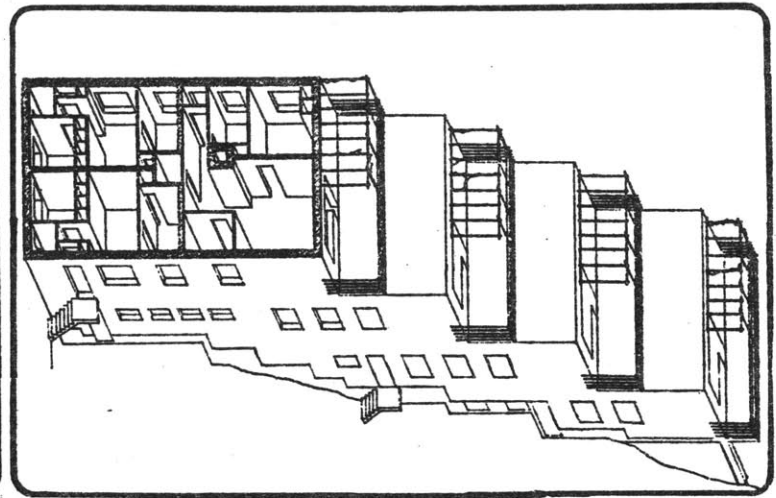
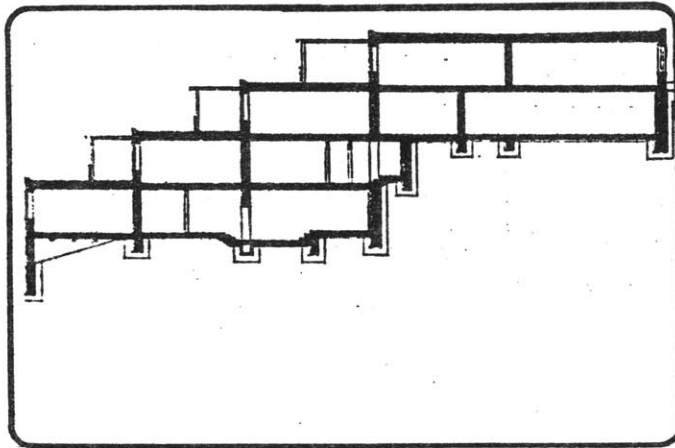
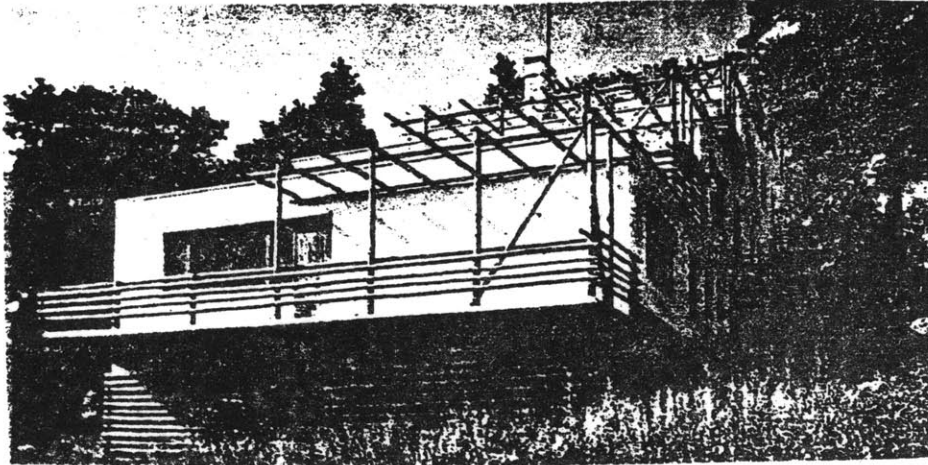

---

**Project;** Kauttua Finland  
**Architect;** Alvar Aalto

---

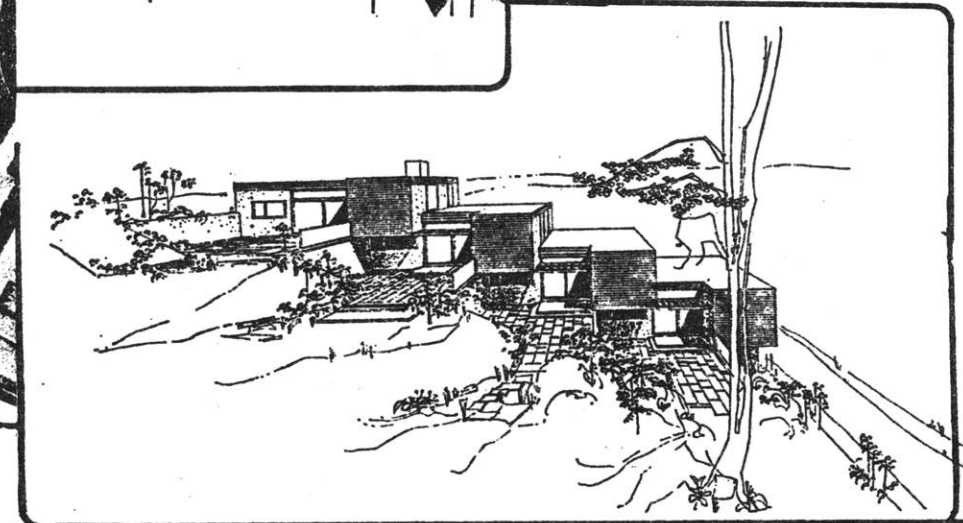
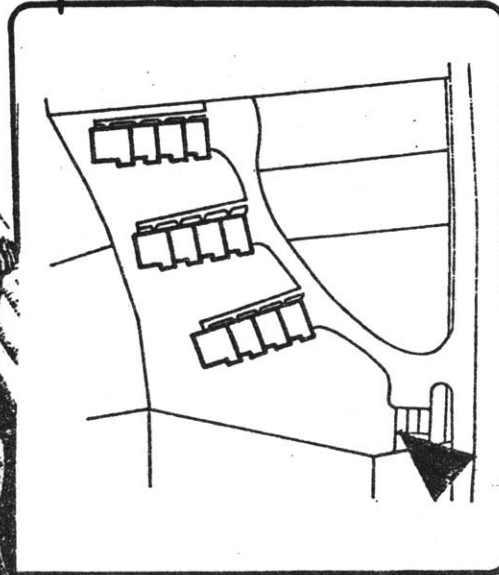
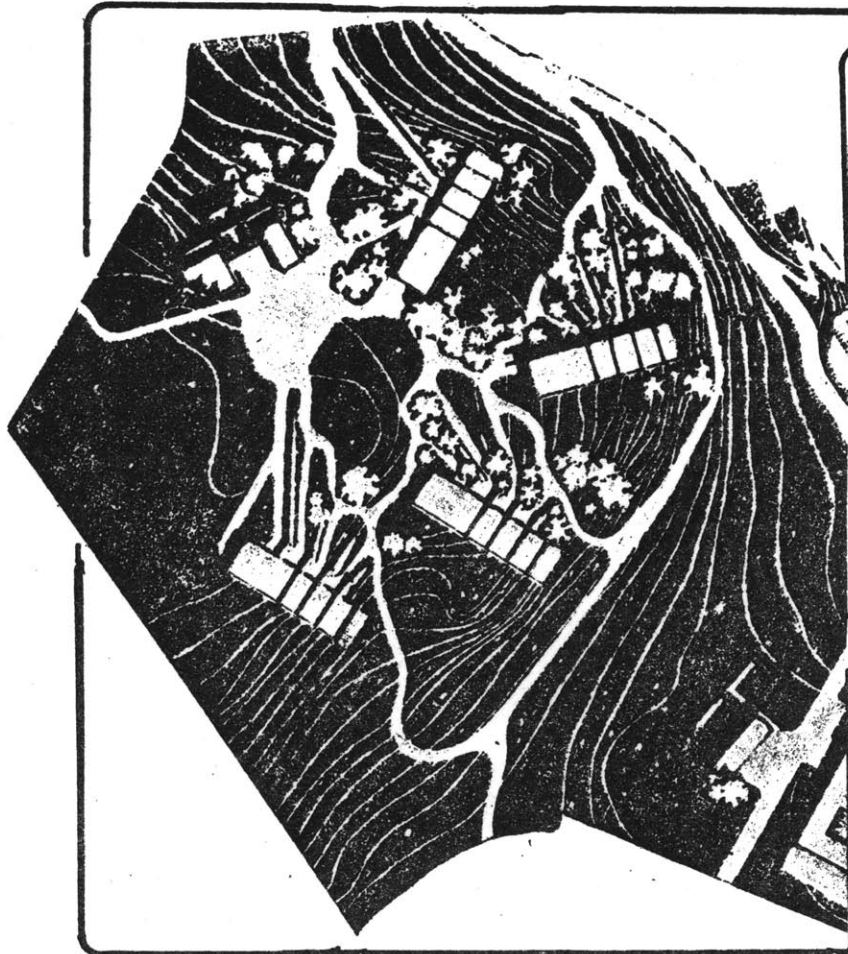

**Project ;** Kauttua Finland  
**Architect ;** Alvar Aalto

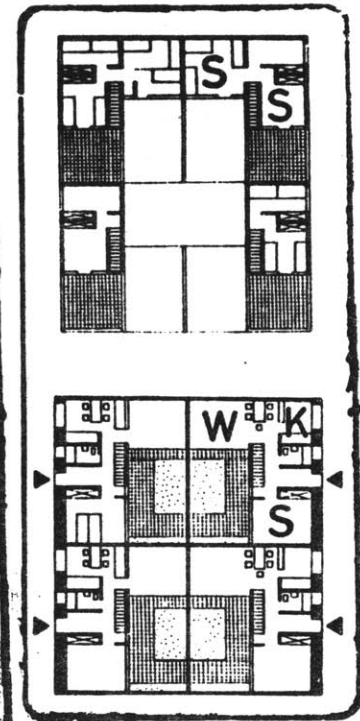
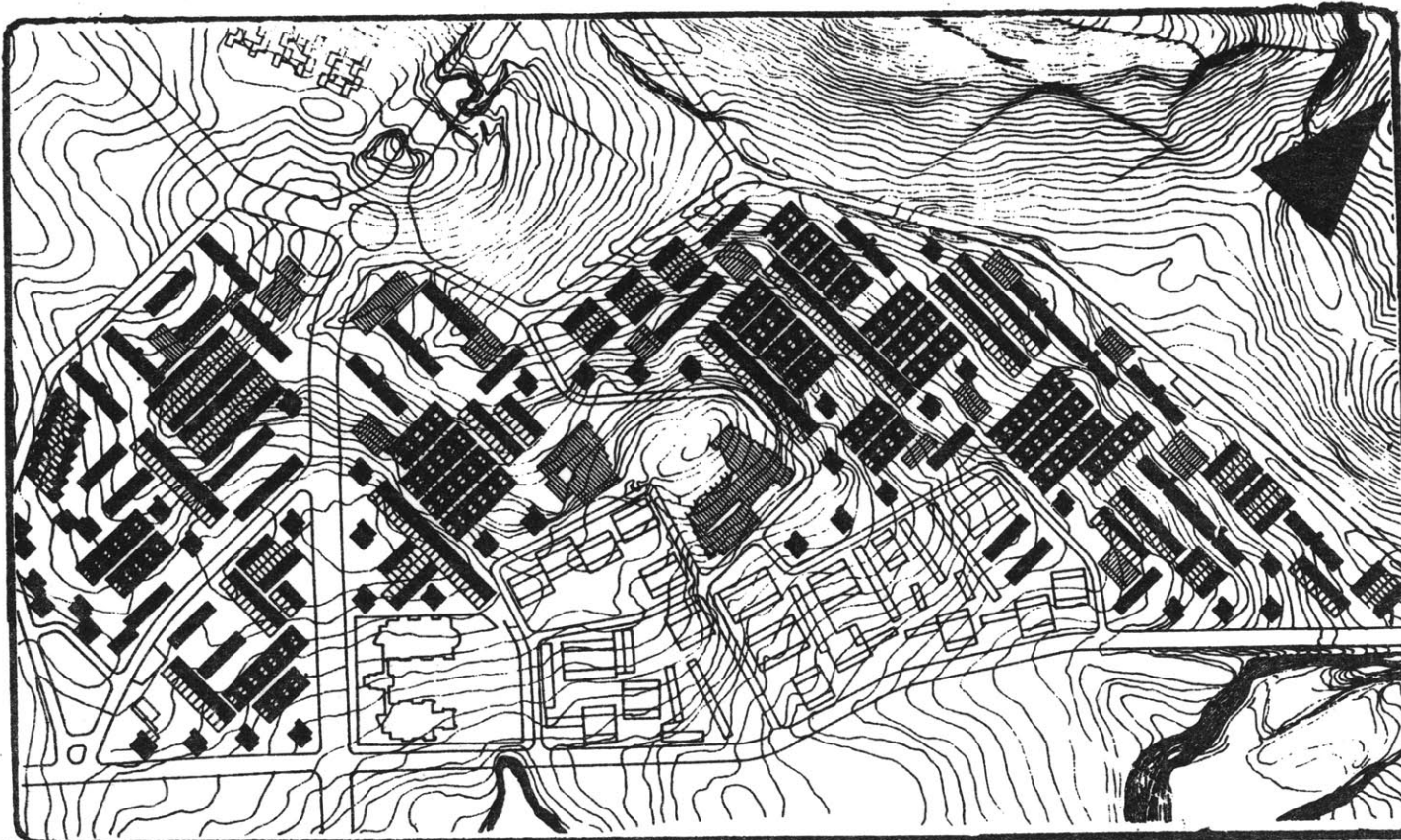

Project ; Cano Roto, Madrid

Architect ; Jose L.I. de Onzono-A.V. de Castro

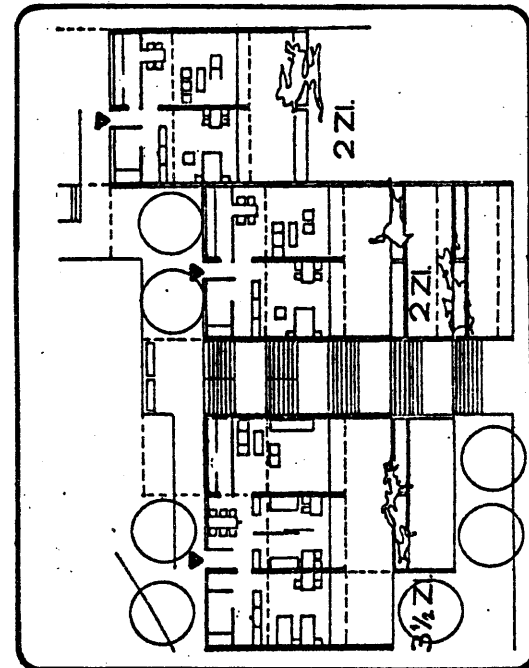
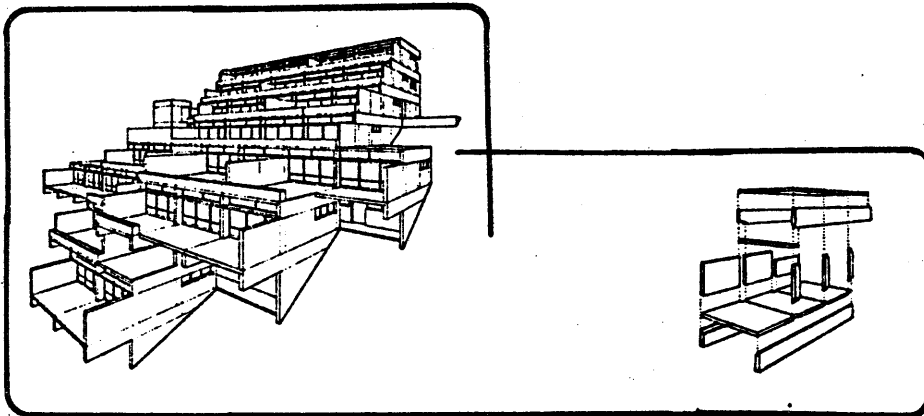
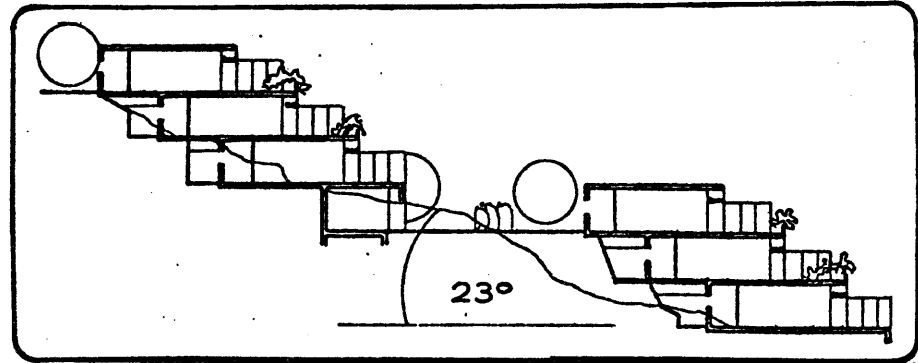
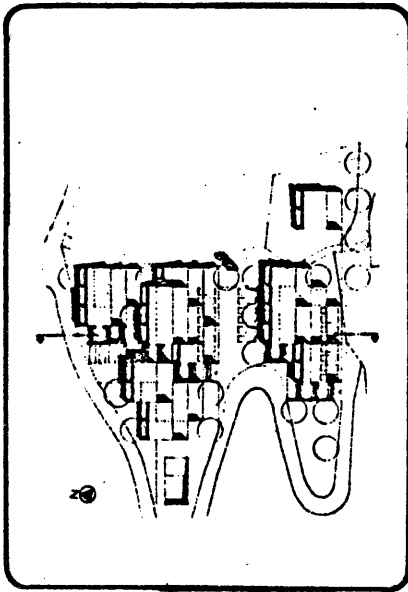

Project ; Orselina, Locarno, Corsier, Suisse  
Architect ; Erwin Mühlestein

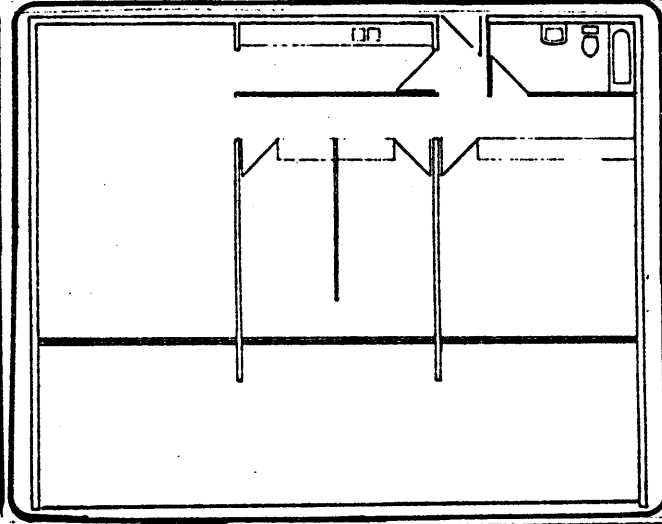
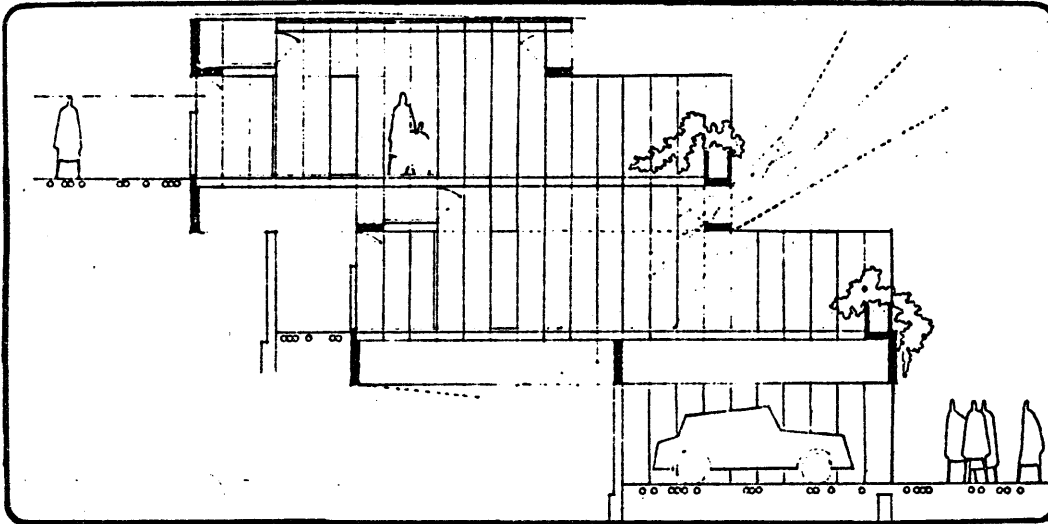
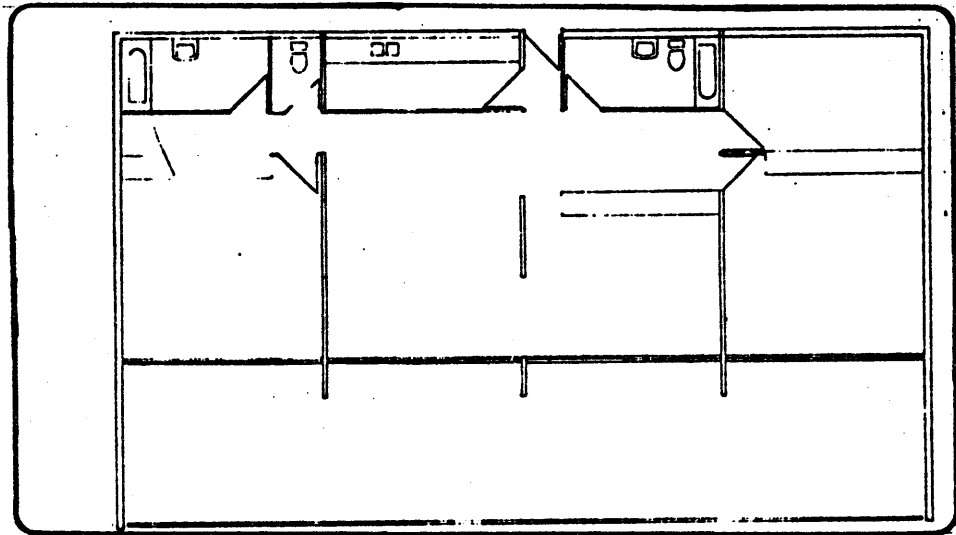
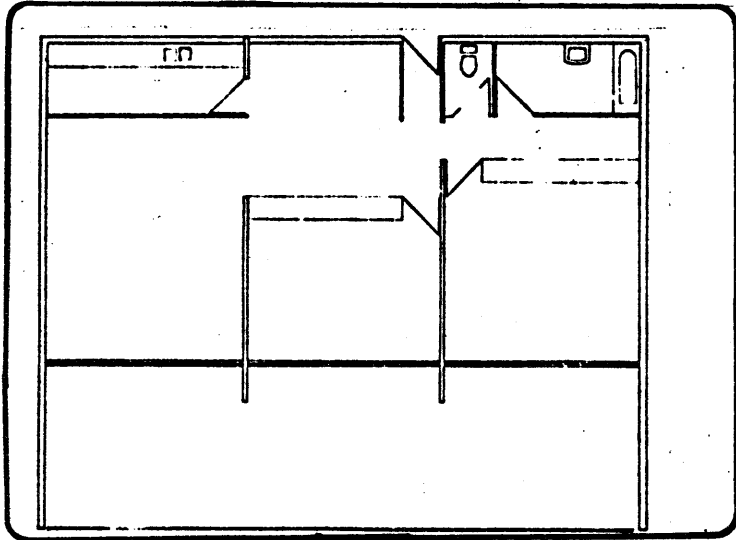

Project ; Orselina, Locarno, Corsier, Suisse  
Architect ; Erwin Mühlestein

13



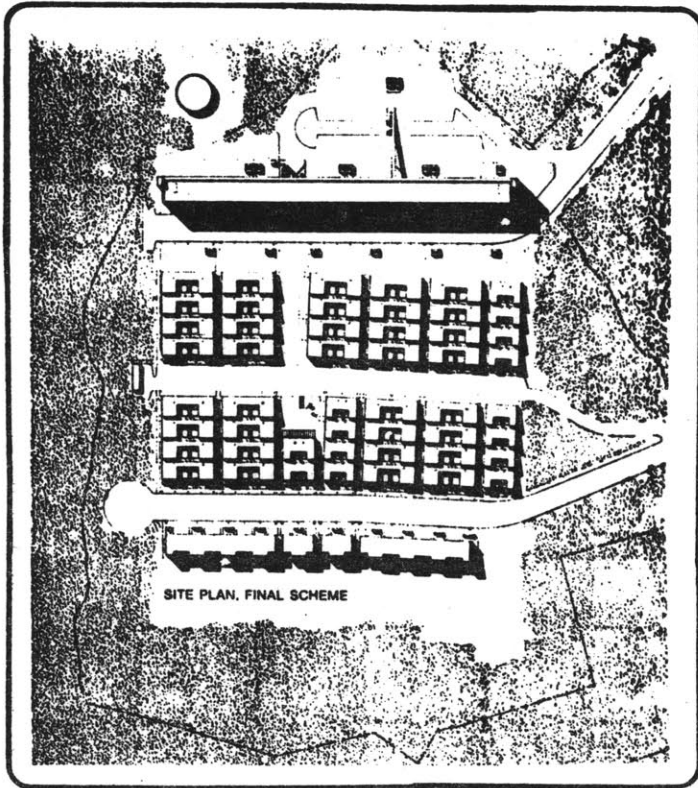

---

**Project ;** Ithaca housing N.Y.

**Architect ;** Werner Seligmann and Associates

---

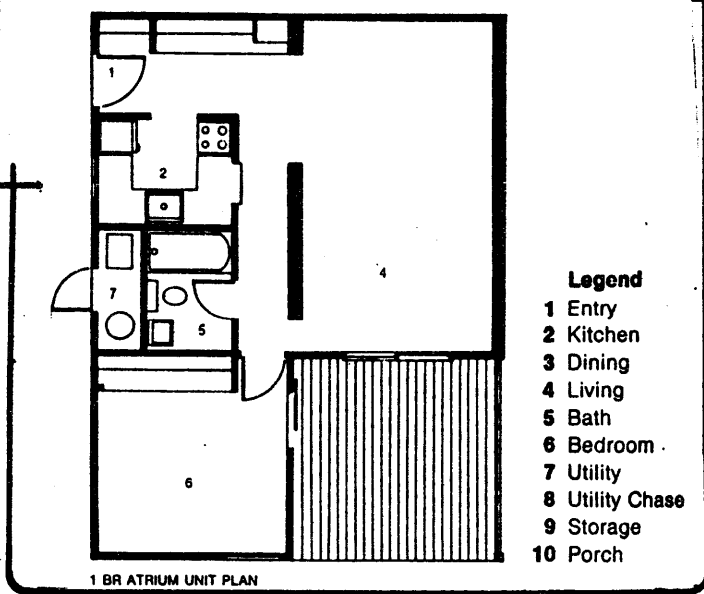
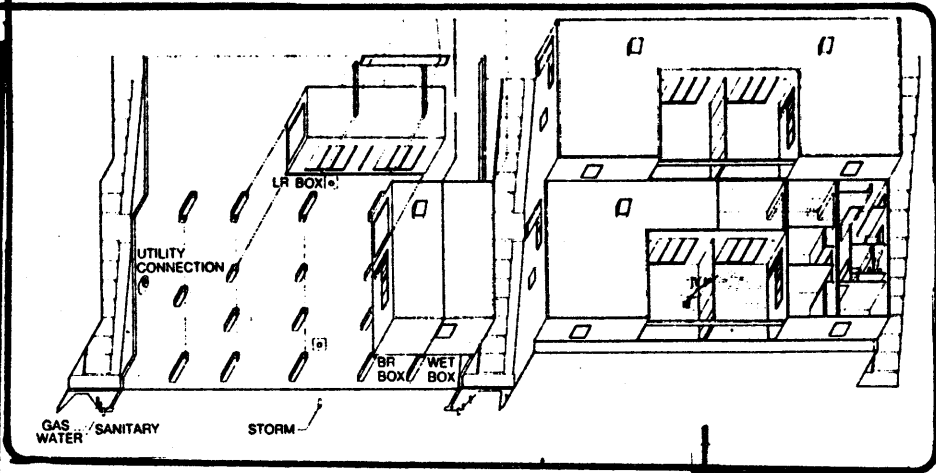
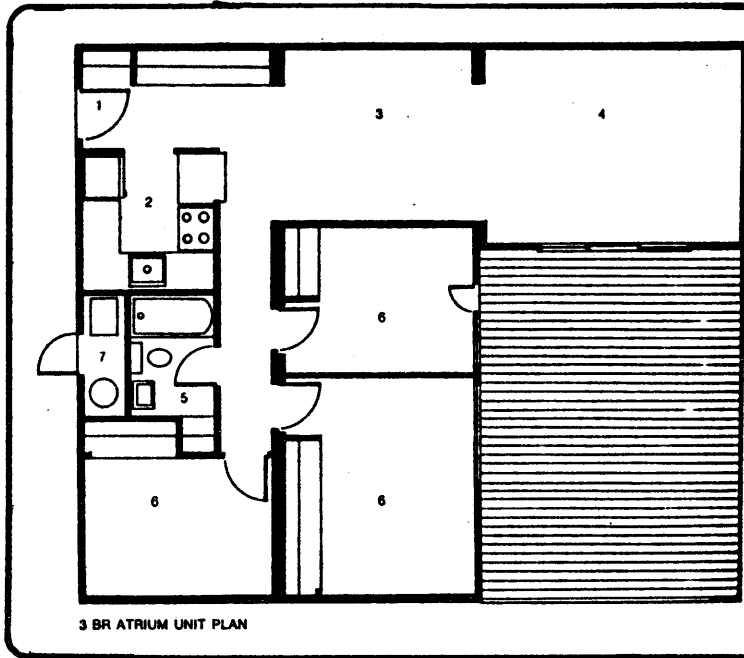

- Legend**
- 1 Entry
  - 2 Kitchen
  - 3 Dining
  - 4 Living
  - 5 Bath
  - 6 Bedroom
  - 7 Utility
  - 8 Utility Chase
  - 9 Storage
  - 10 Porch

Project ; Ithaca housing N.Y.

Architect ; Werner Seligmann and Associates

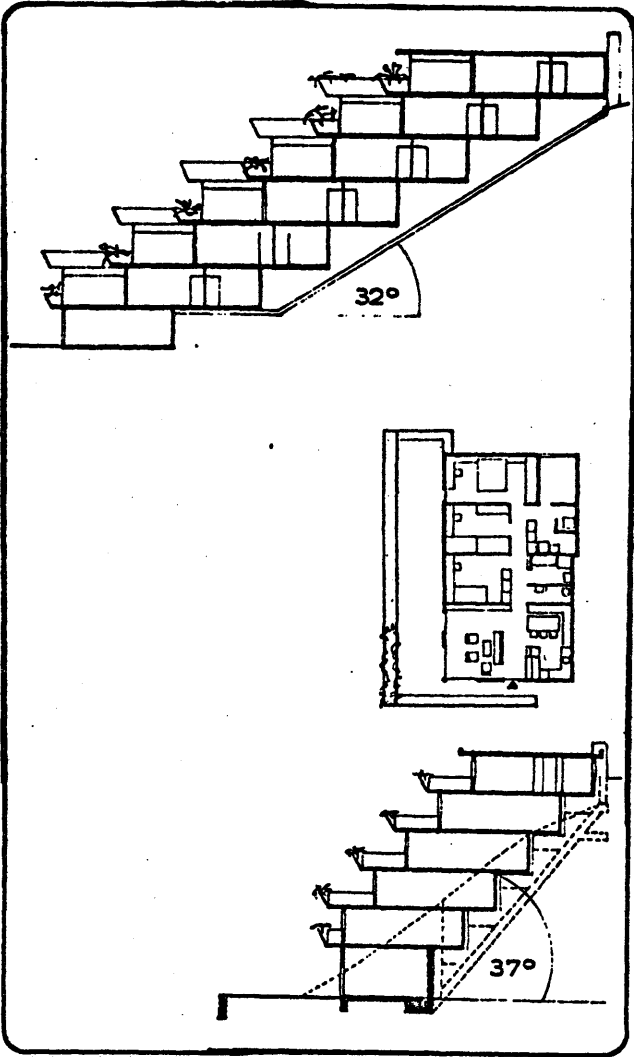
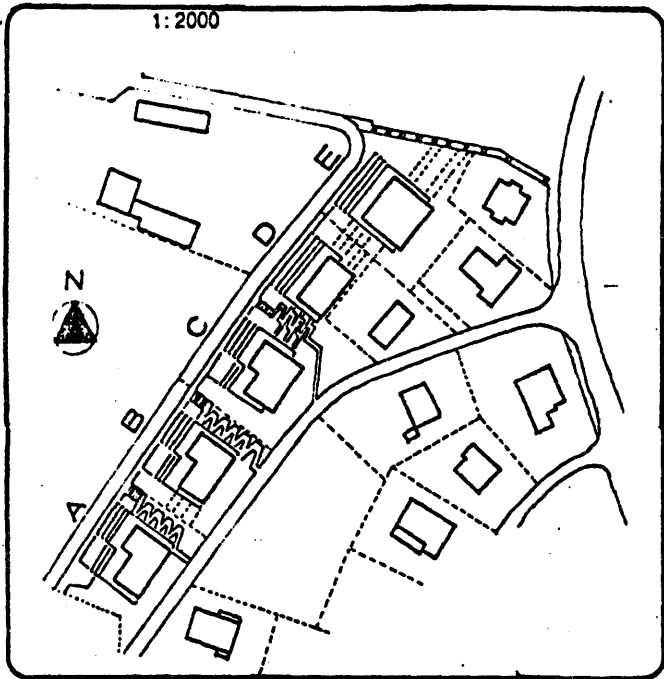

Project; Zug Swisse  
Architect; F. Stucky & R. Meull

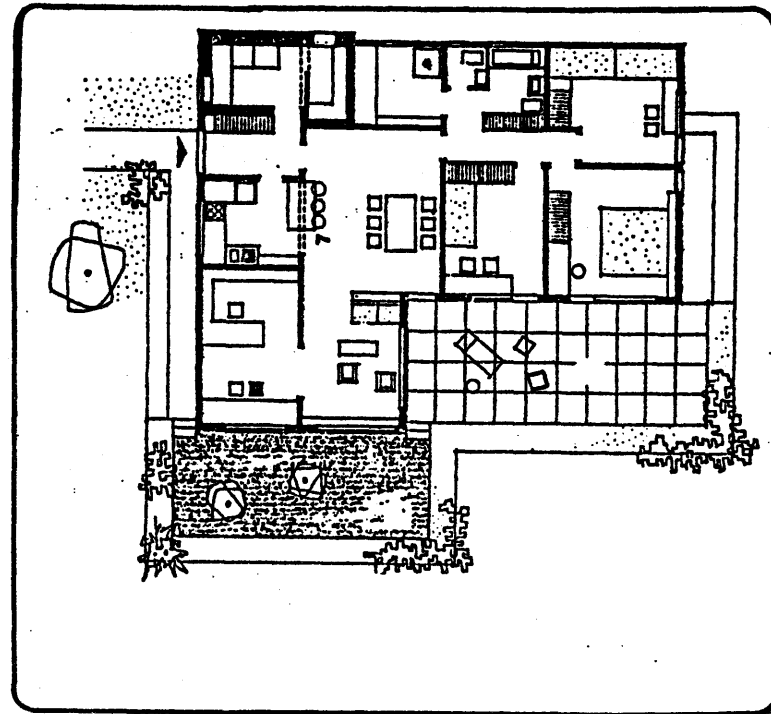
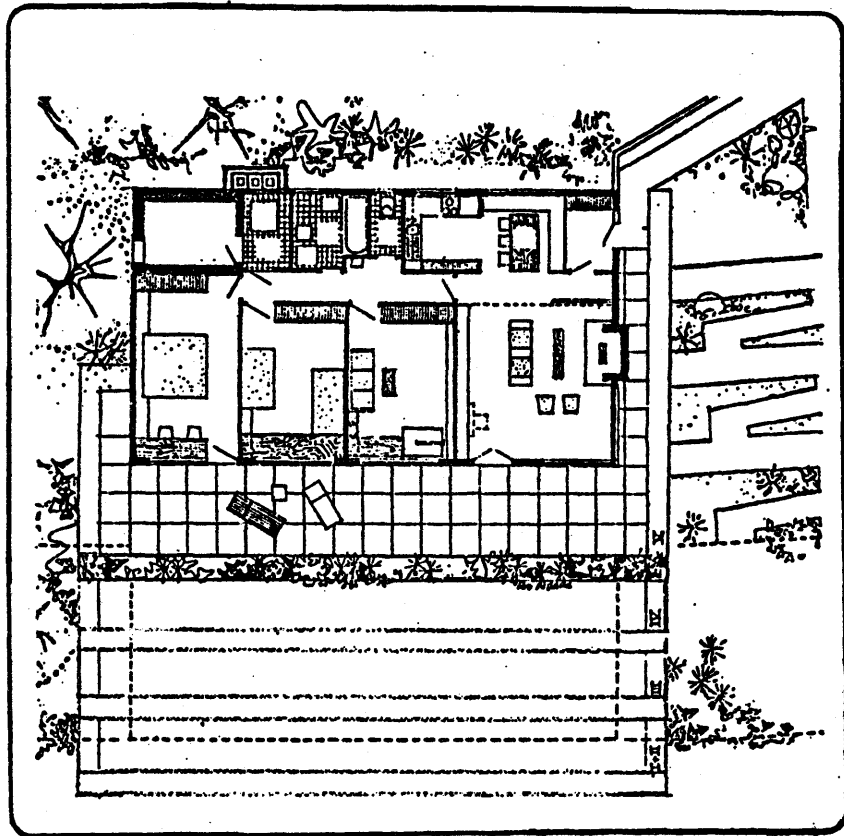

---

Project; Zug Swisse  
Architect; F. Stucky & R. Meull

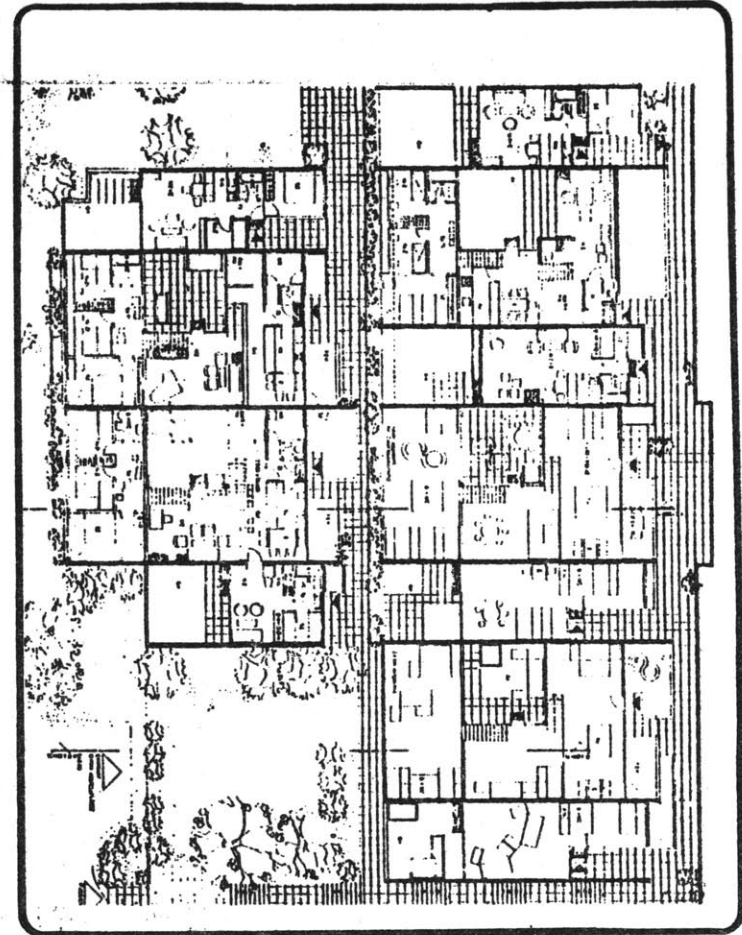
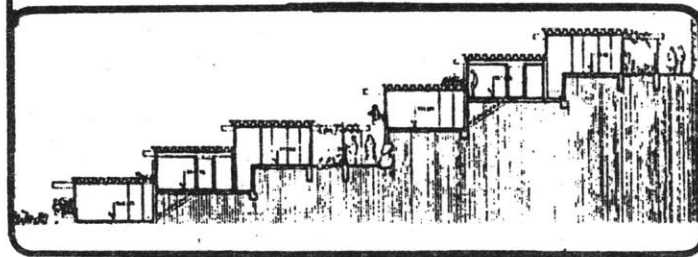
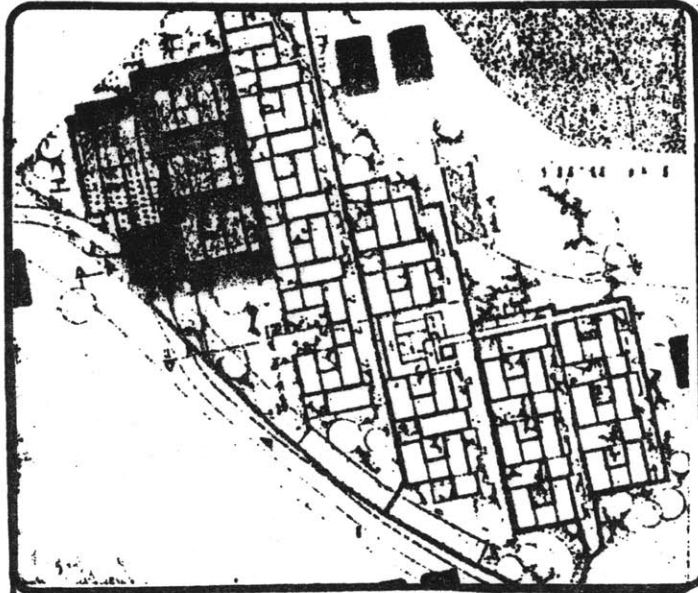

---

**Project;** Mauren Liechtenstein  
**Architect;** Ot Hoffmann

---

- 46 -

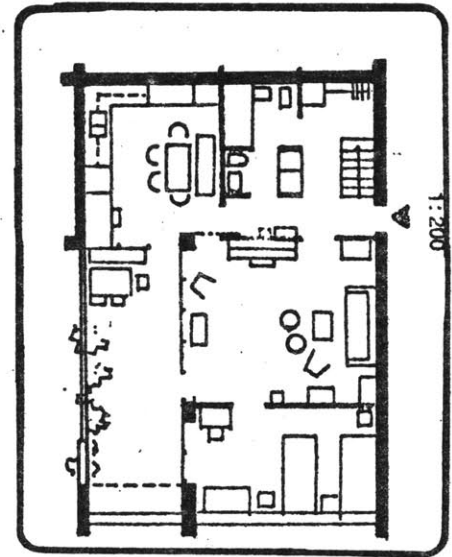
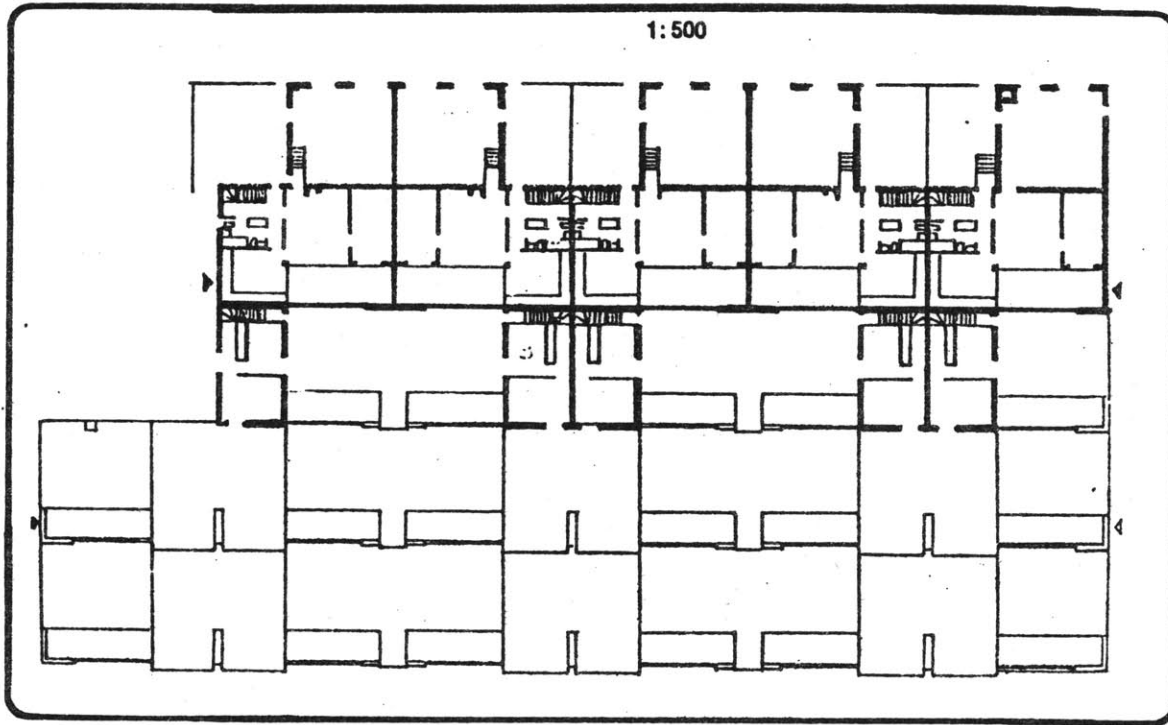
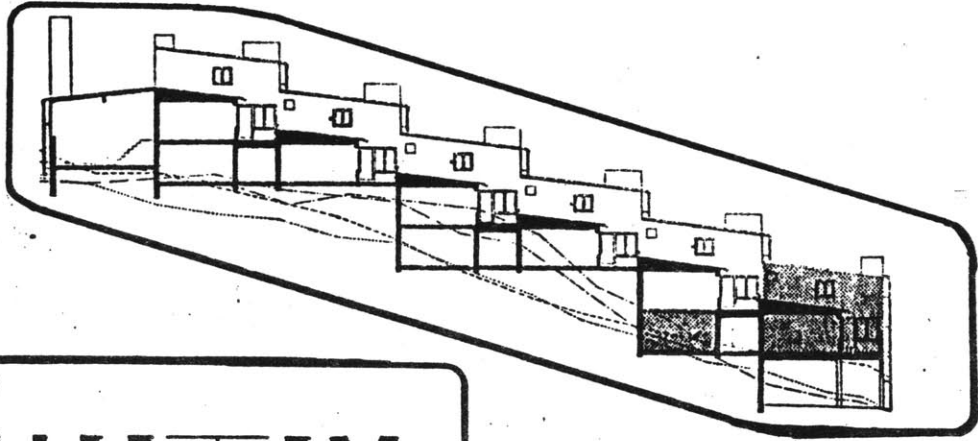
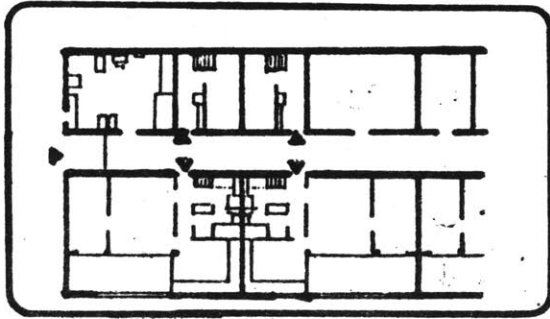

---

**Project;** Skönstavik Stockholm

**Architect;** Axel Kandell

**17**

---

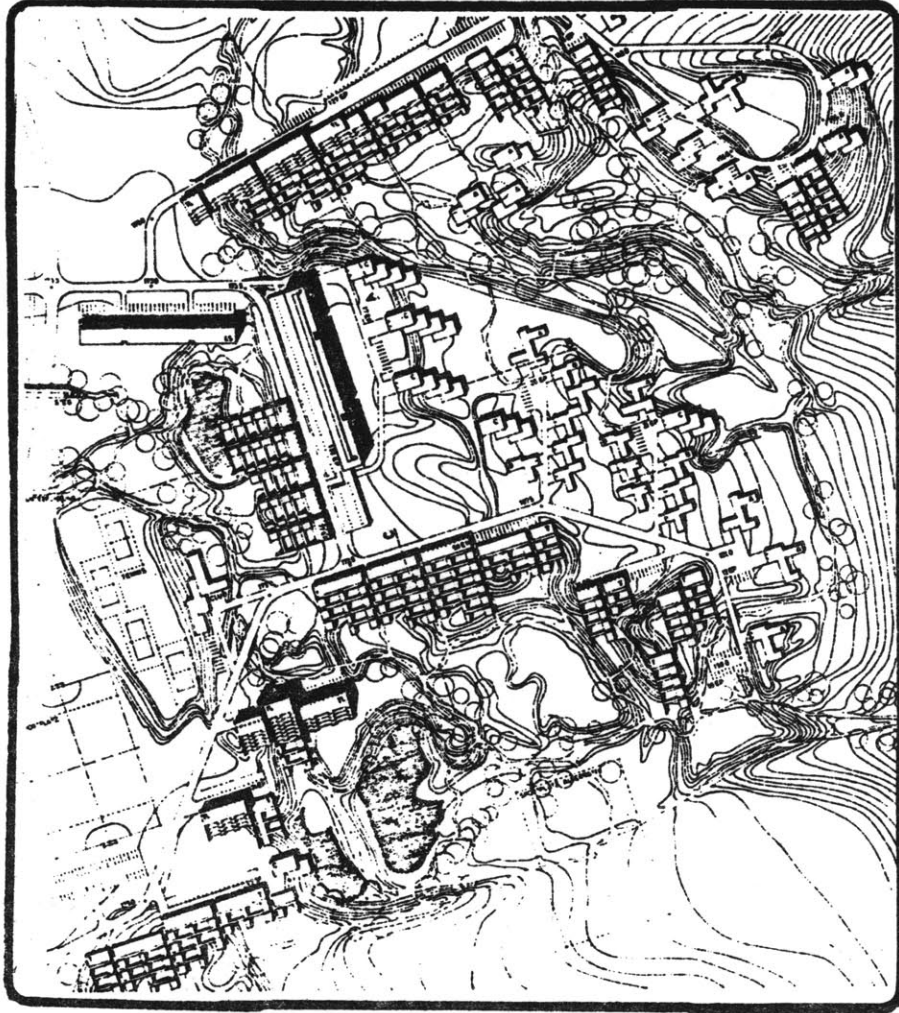

---

Project; "Brüggliacher" Baden Swisse  
Architect; Hans Ulrich Scherer.

---

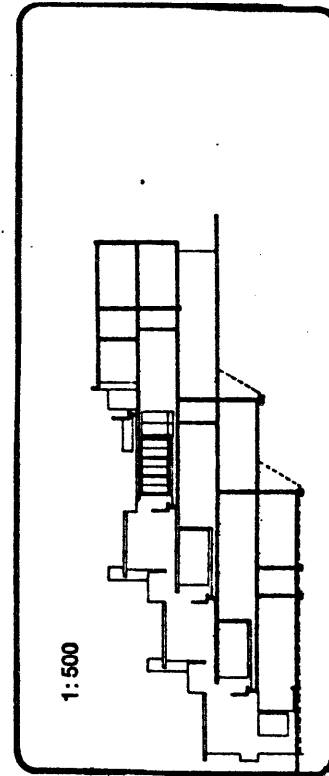
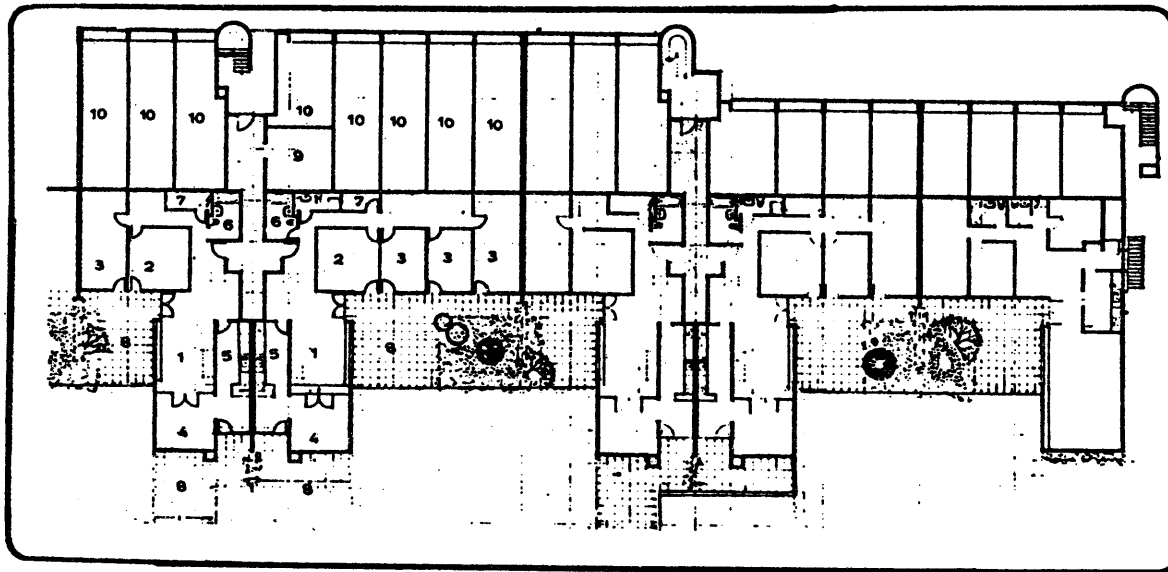
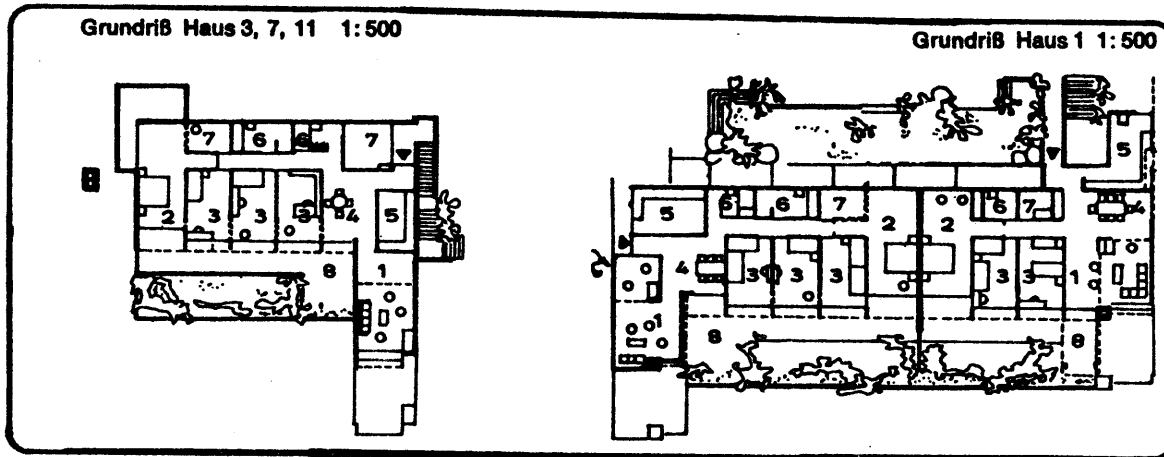

Project; "Brüggliacher" Baden Swisse  
Architect; Hans Ulrich Scherer.



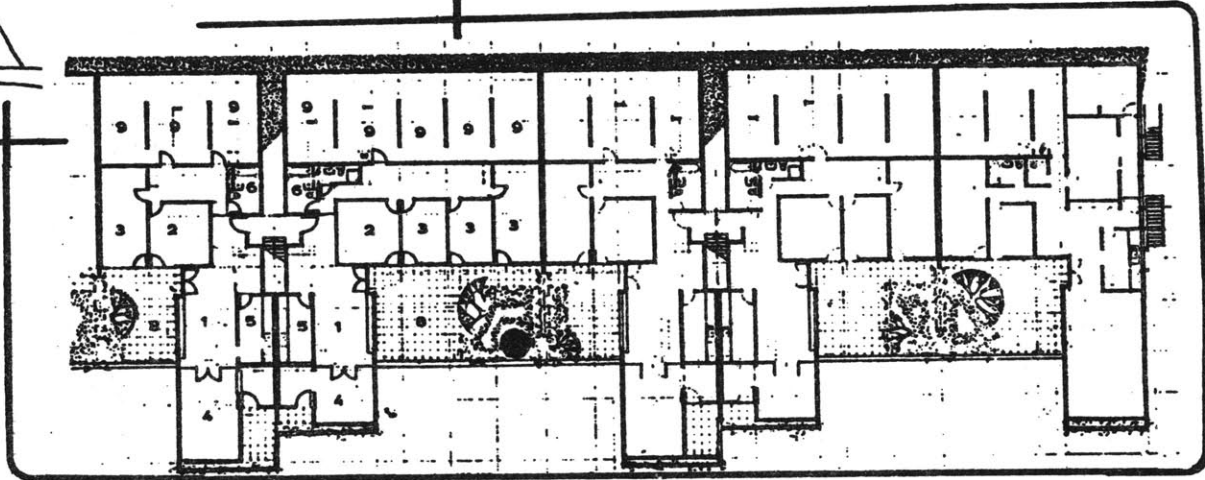
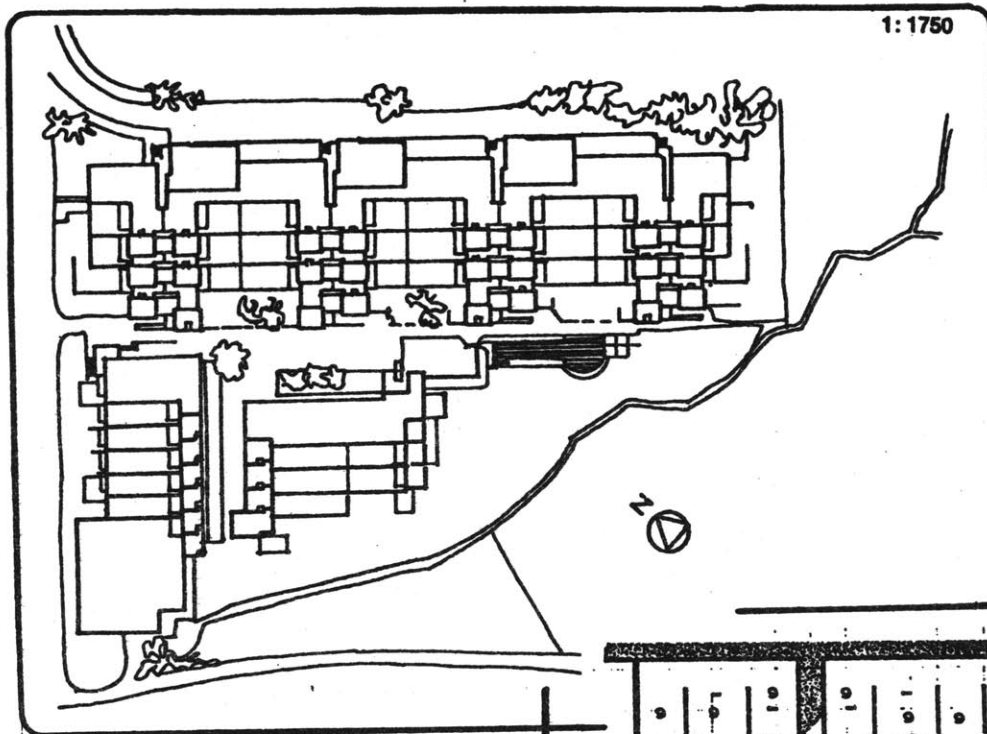

**Project ;** "Brüggliacher" Baden Swisse

**Architect ;** Hans Ulrich Scherer.

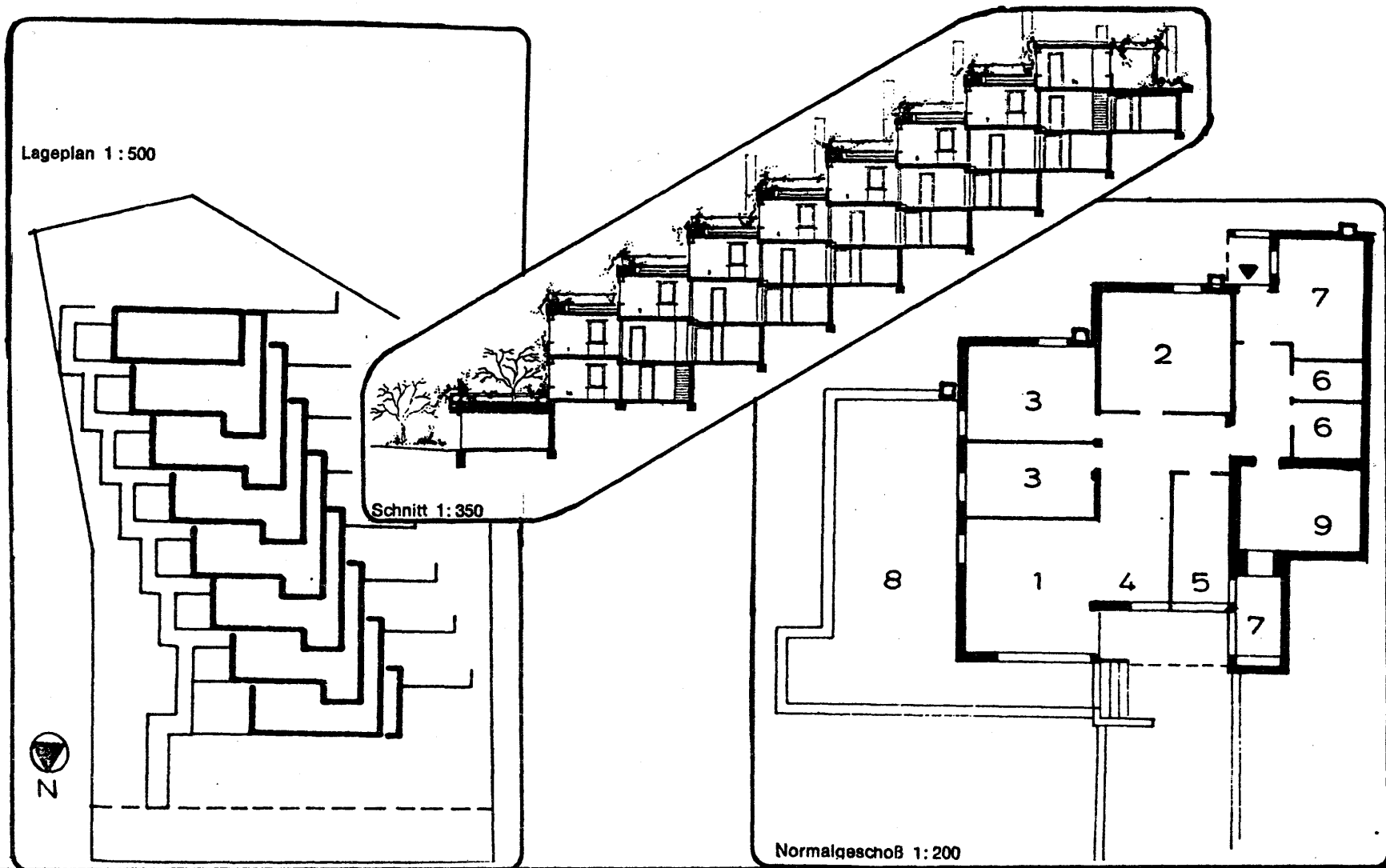

**Project**; Pratteln Swisse

**Architect**; U. Remund; H. Alioth

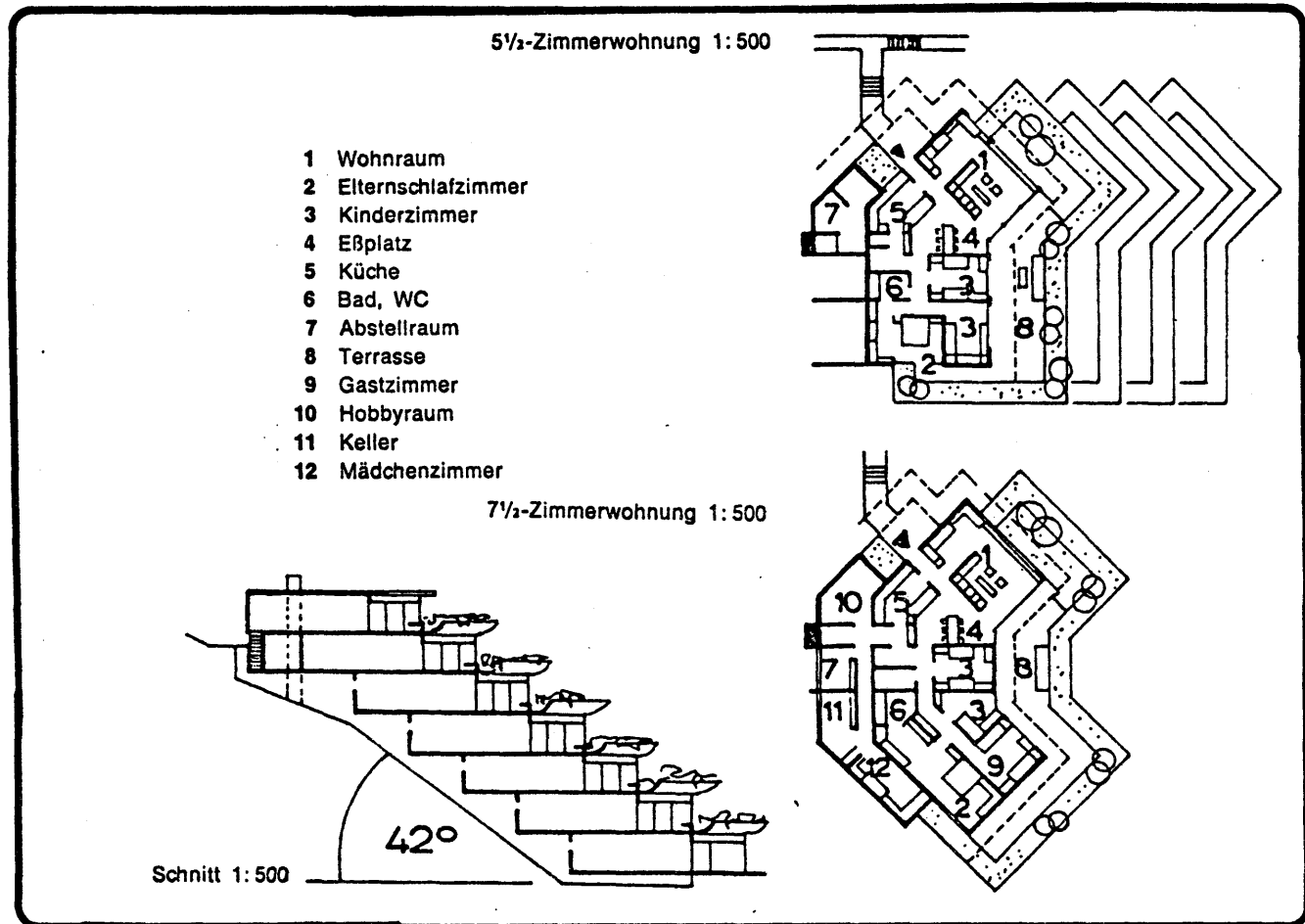

Project; Bäch-Freienbach Swisse

Architect; B.L.Hir & R.Michel.

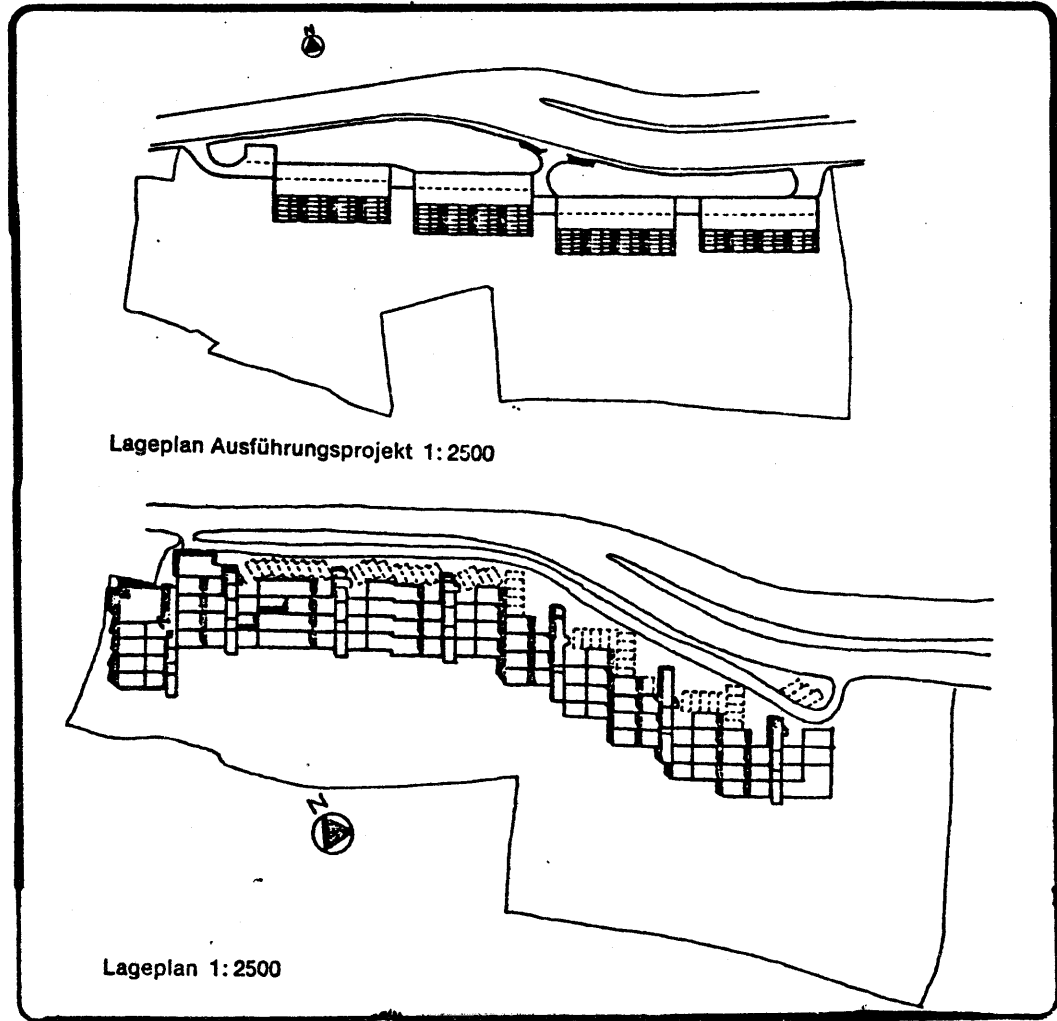

Project; Roquebrune France

Architect; G. Candilis

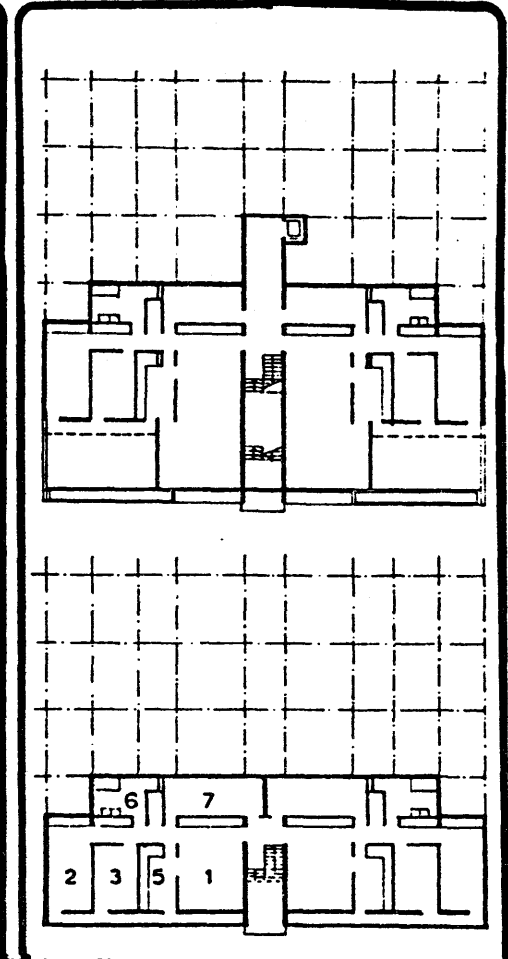
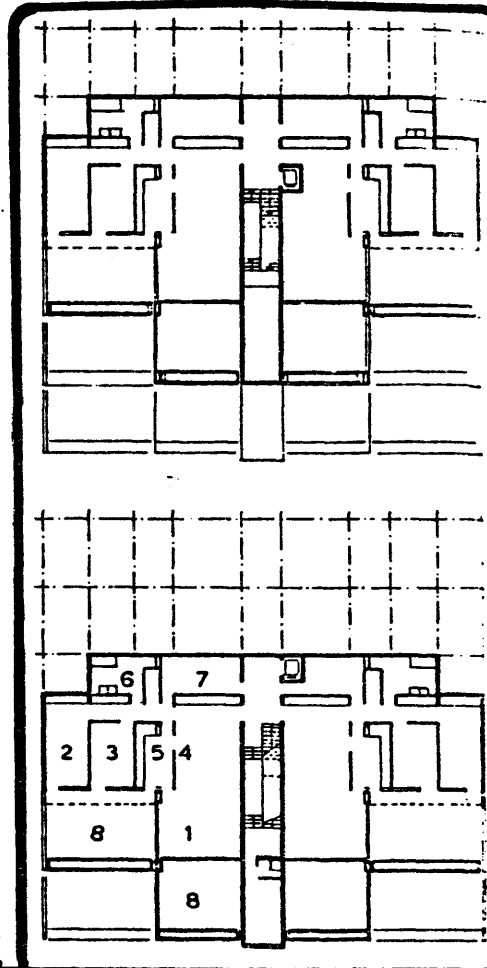
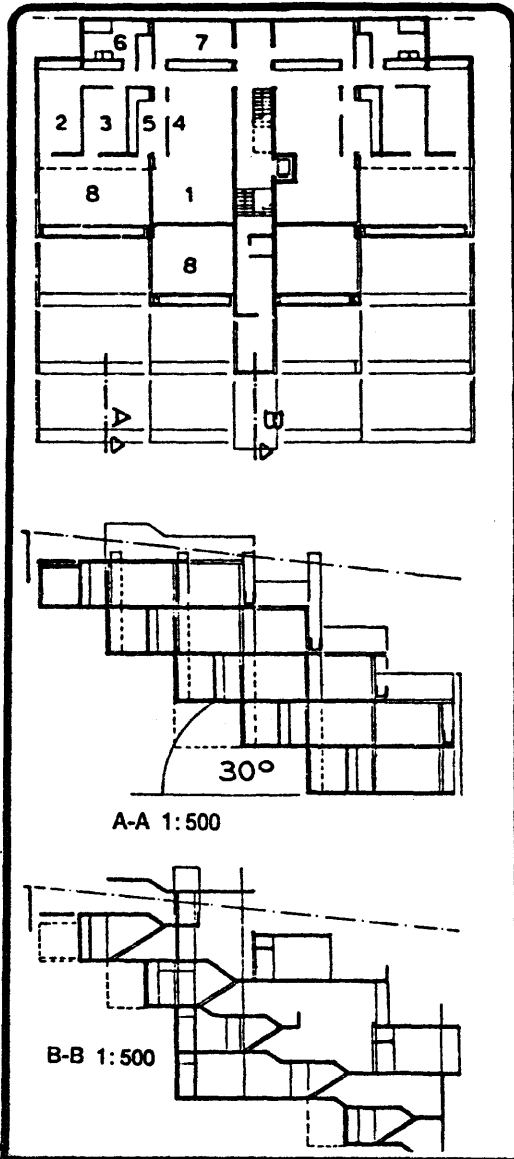

Project ; Roquebrune France

Architect ; G. Candilis

-5A-

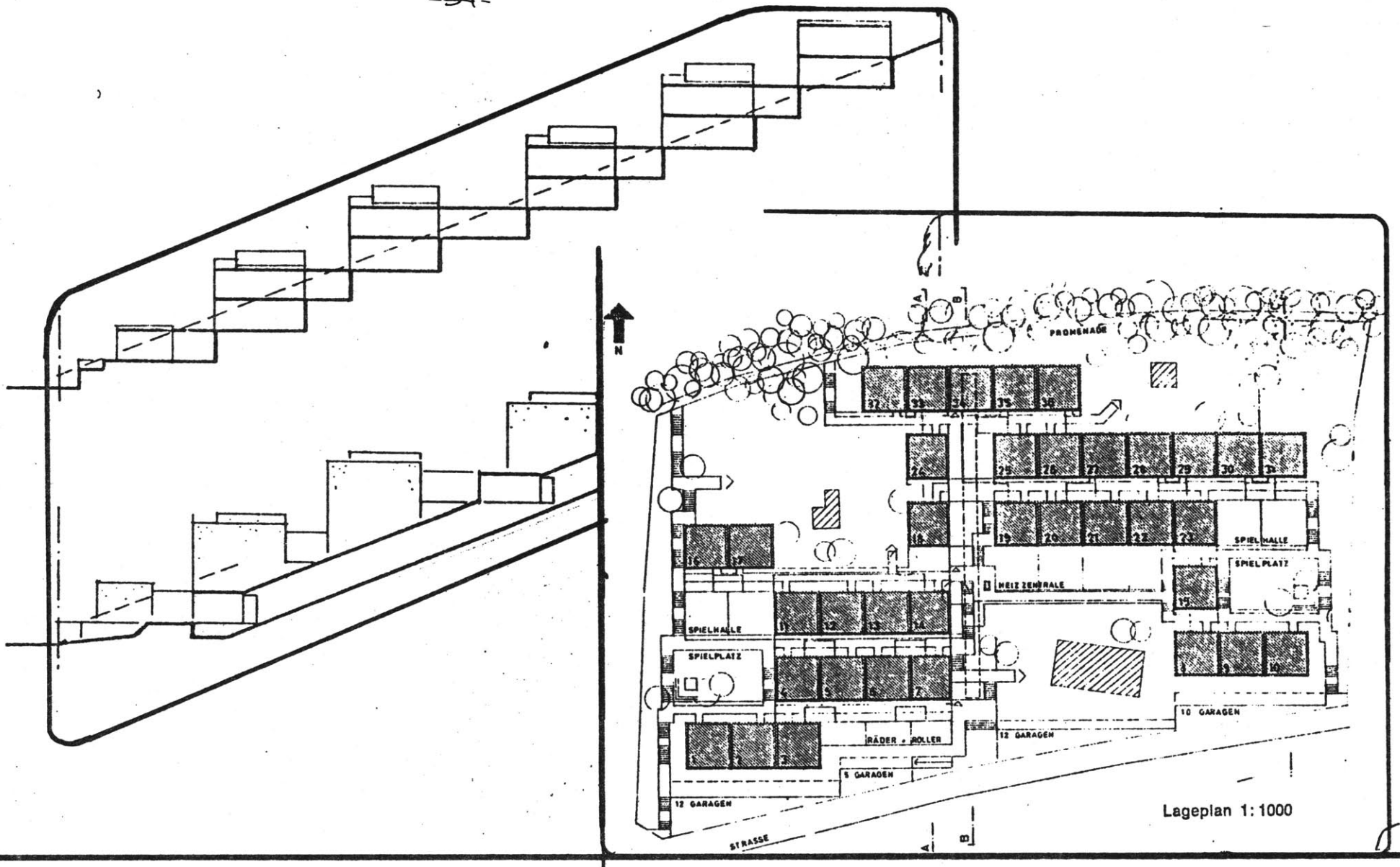

**Project ;** Grenzach Germany

**Architect ;** C.P. Blumer; U. Remund; H. Alioth

**22**

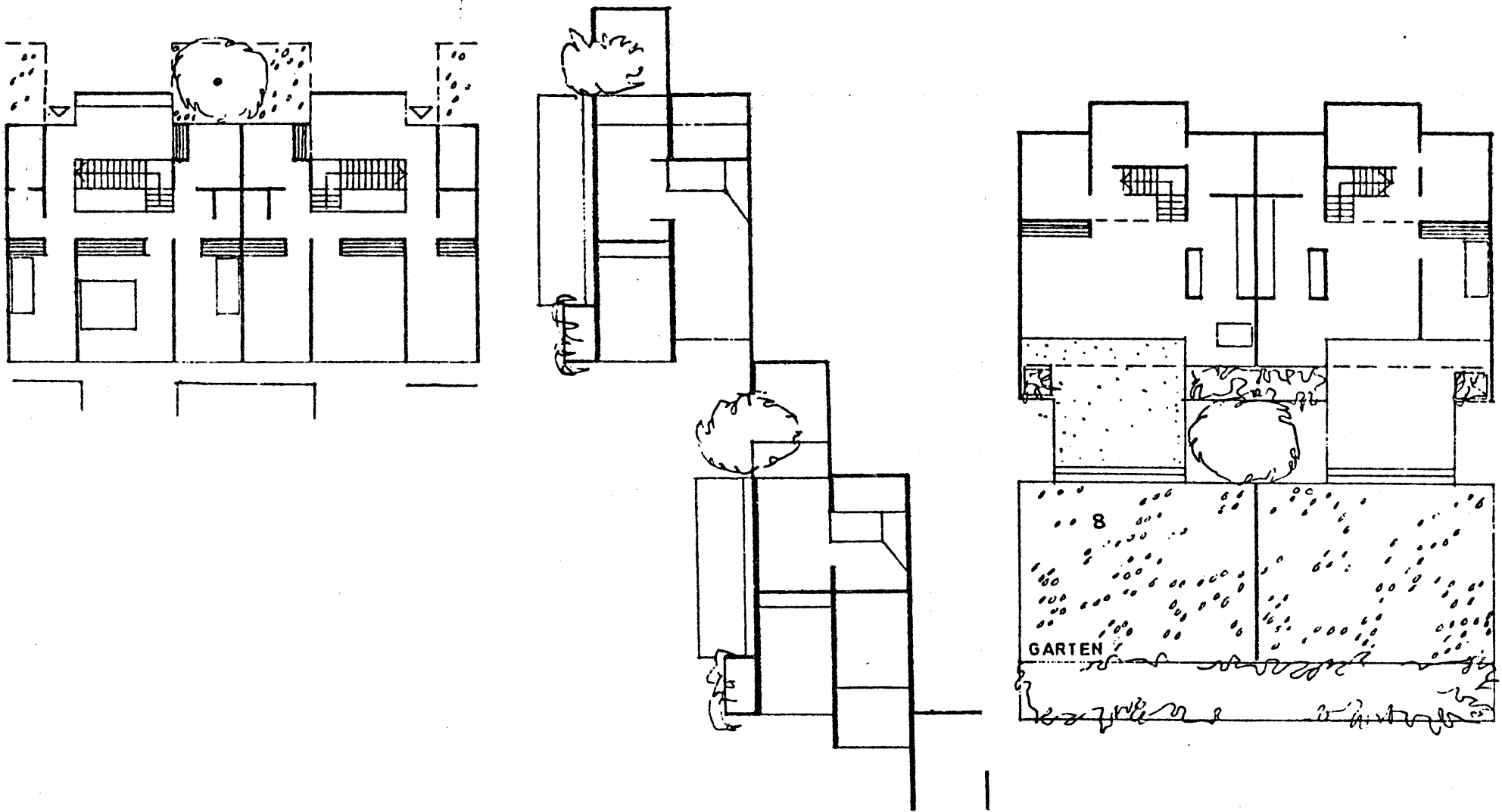

Project; Grenzach Germany

Architect; C.P. Blumer; U. Remund; H. Alioth

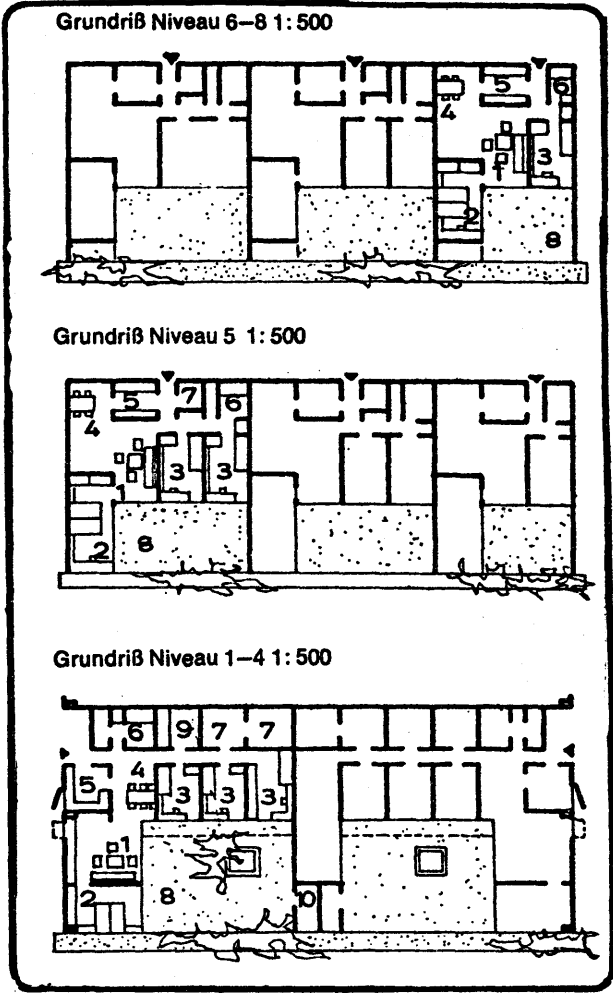
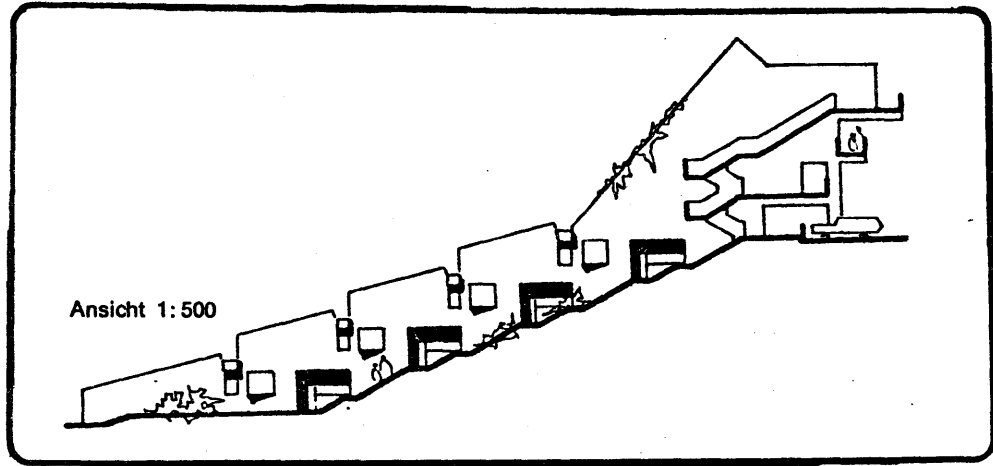
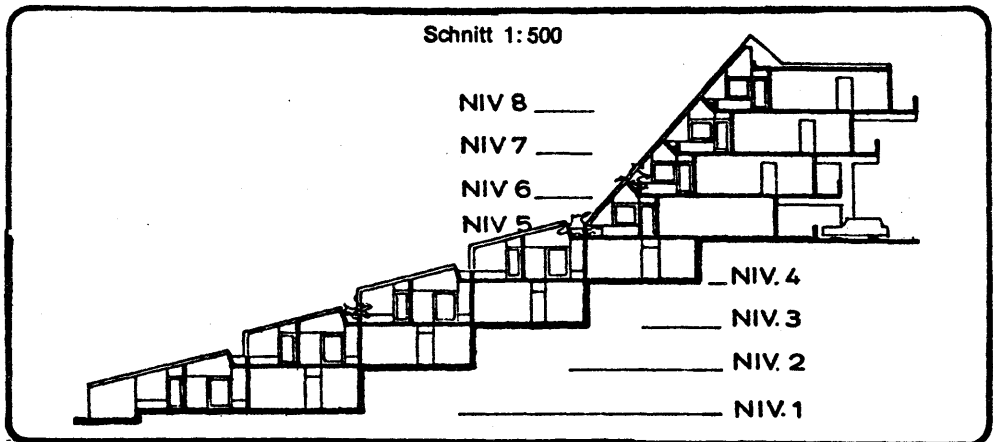

Project; Bad Godesberg, Germany  
Architect; Fallier + Schröder; R. Frey



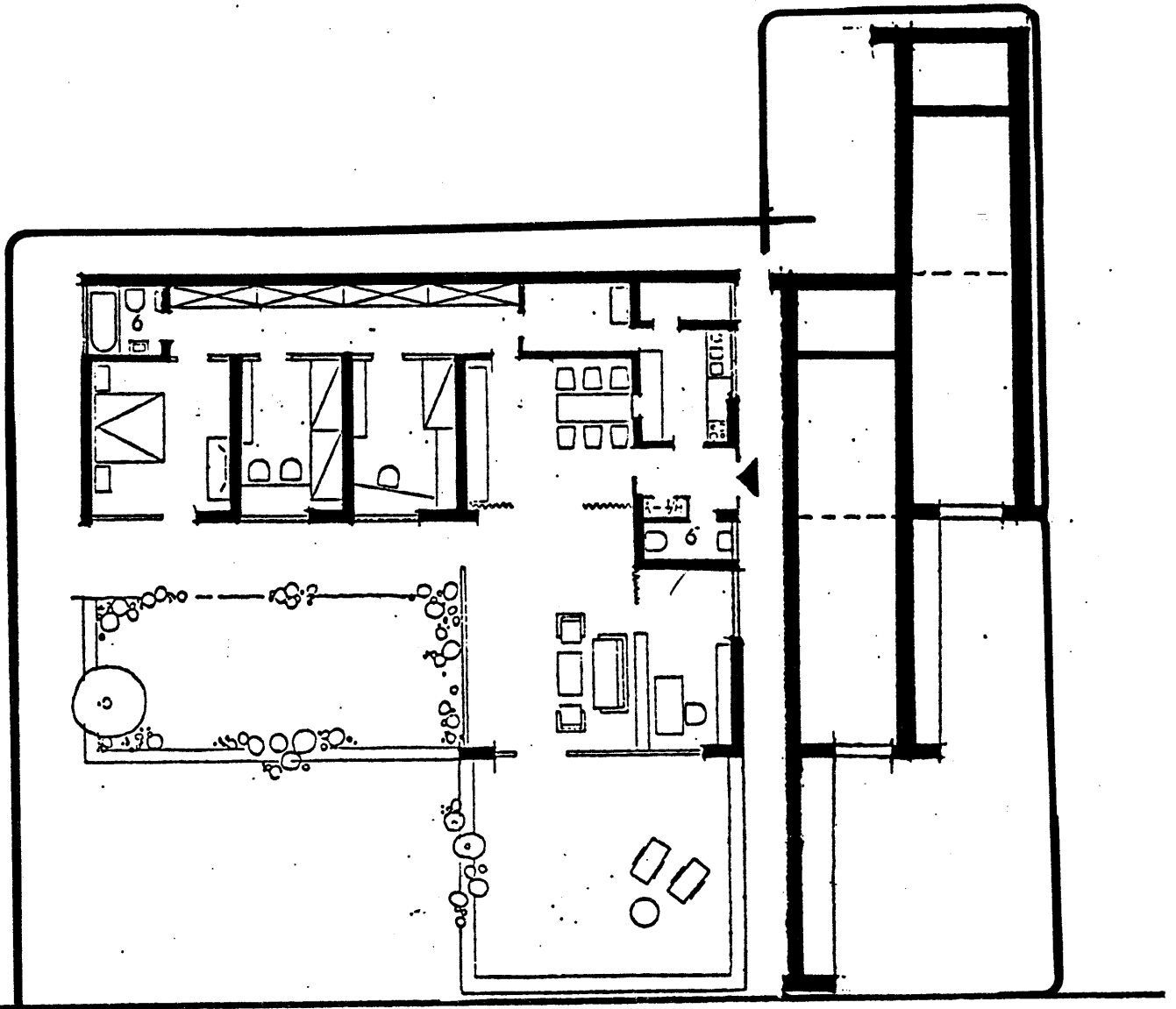
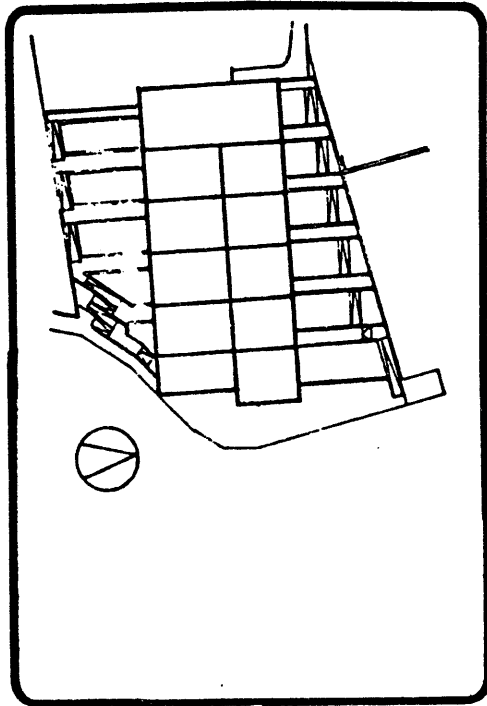

Project ; Freiburg

Architect ; Günter Balser

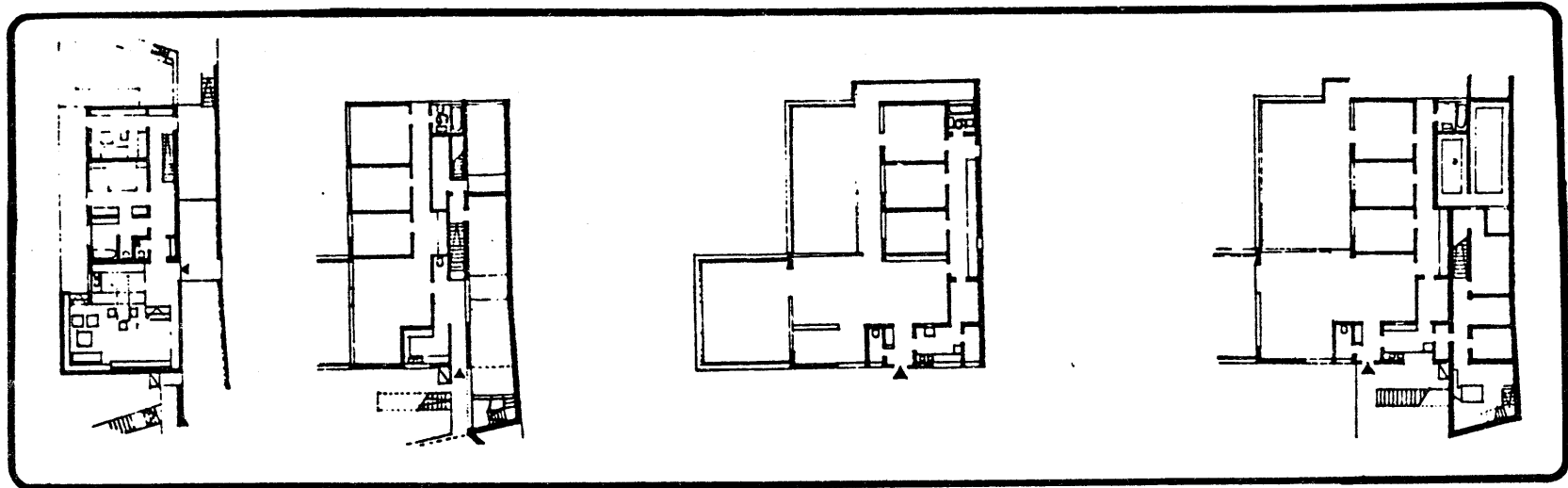
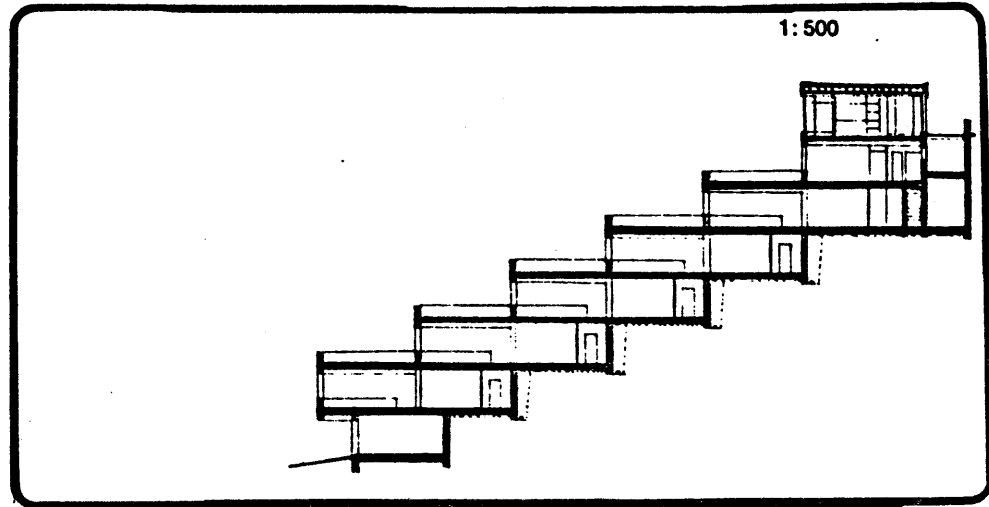

Project ; Freiburg

Architect ; Günter Balsler

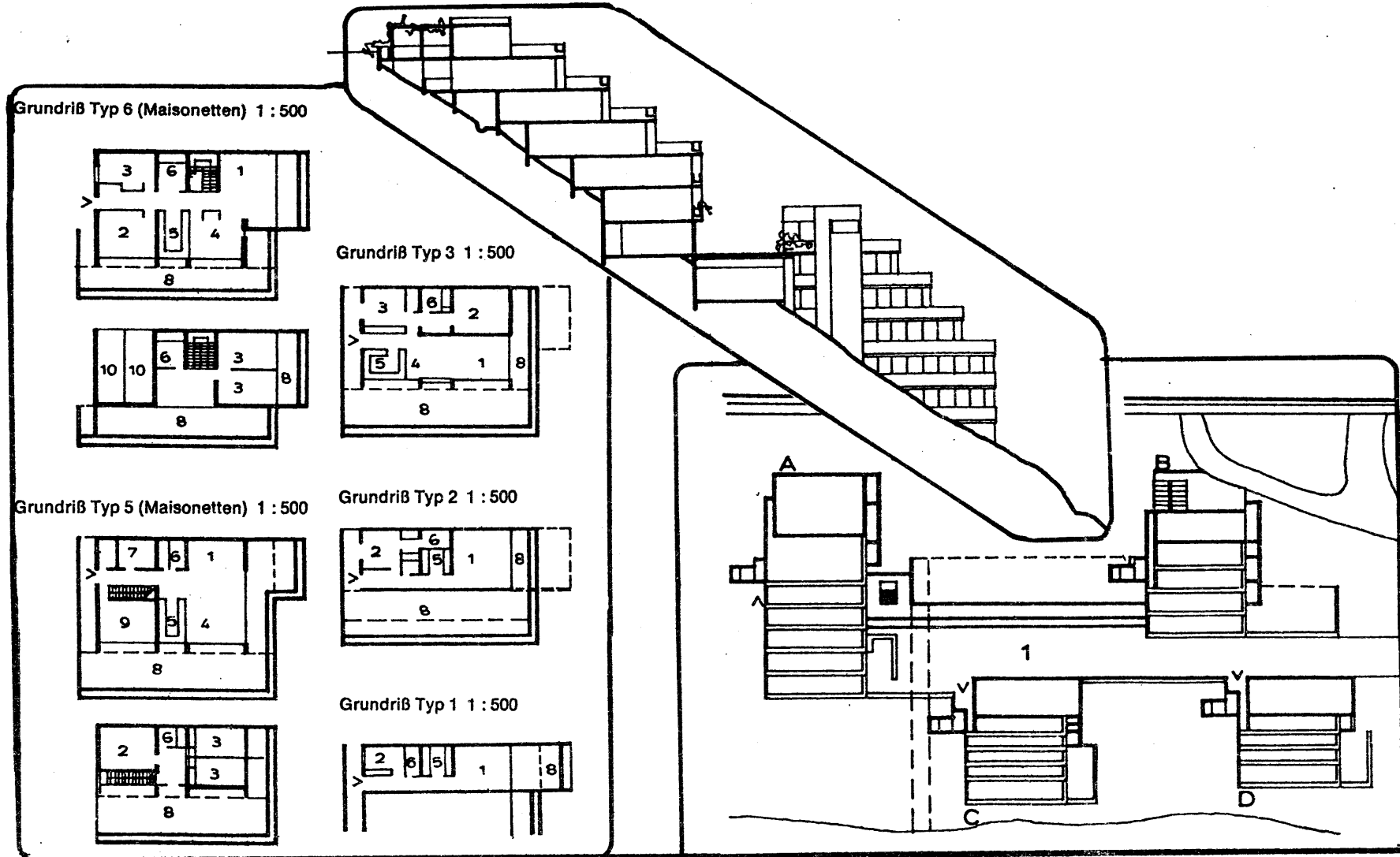

Project; Hornberg  
Architect; Rainer Disse

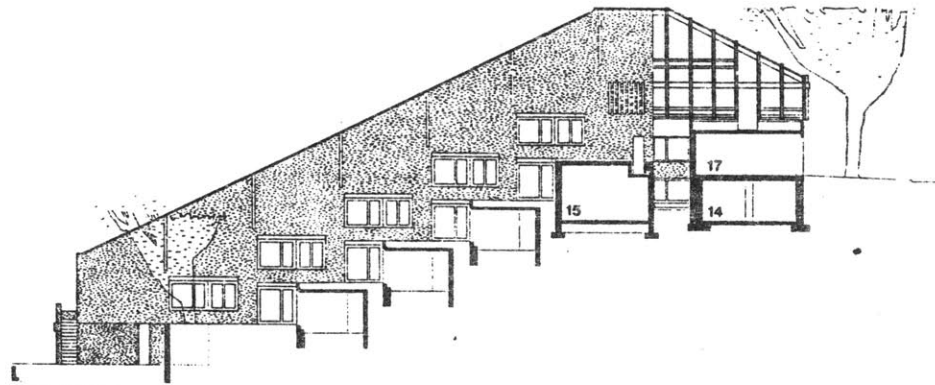
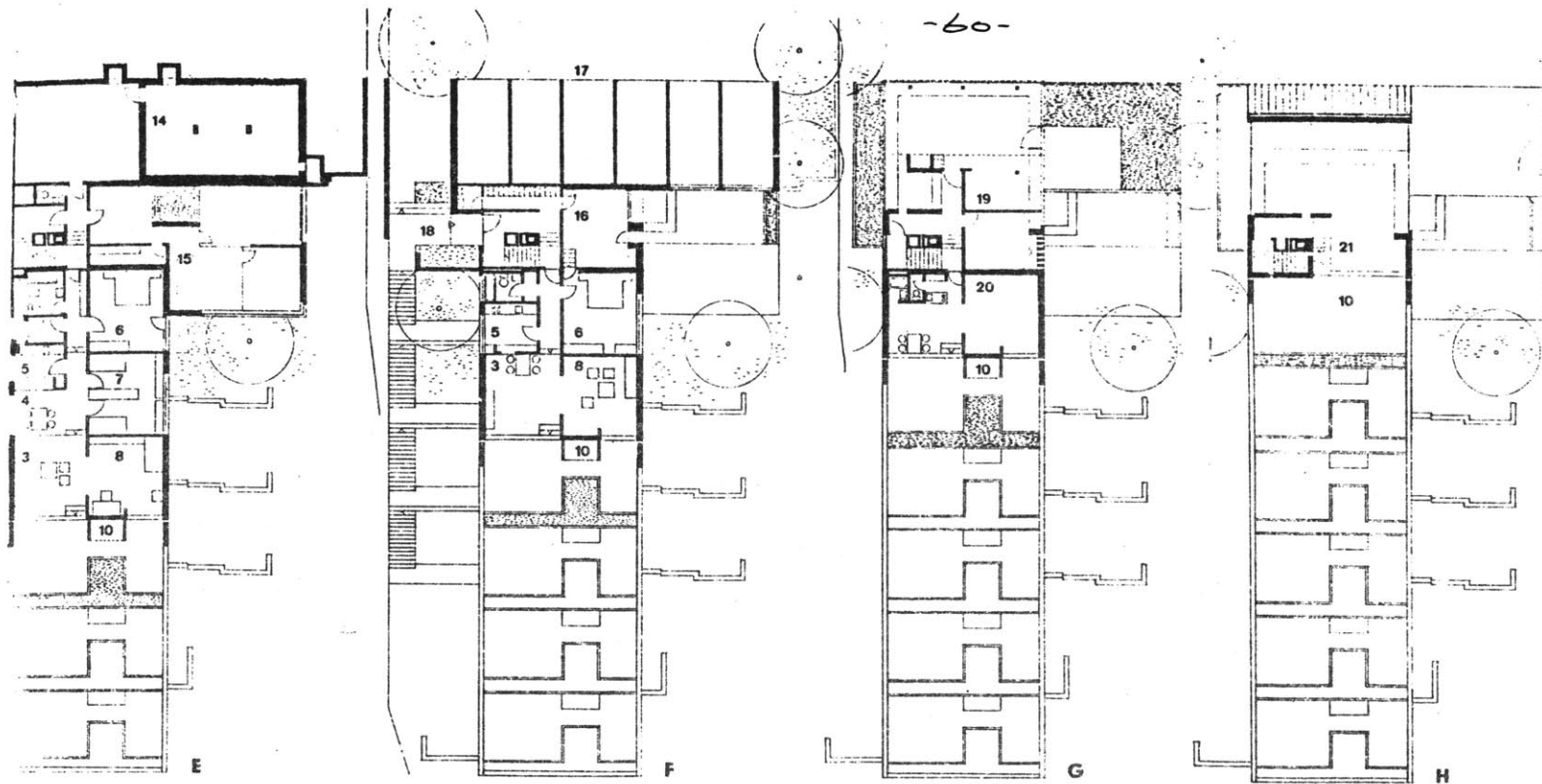

Project ; Witikon Zürich Swisse  
Architect ; C Paillard P Leemann

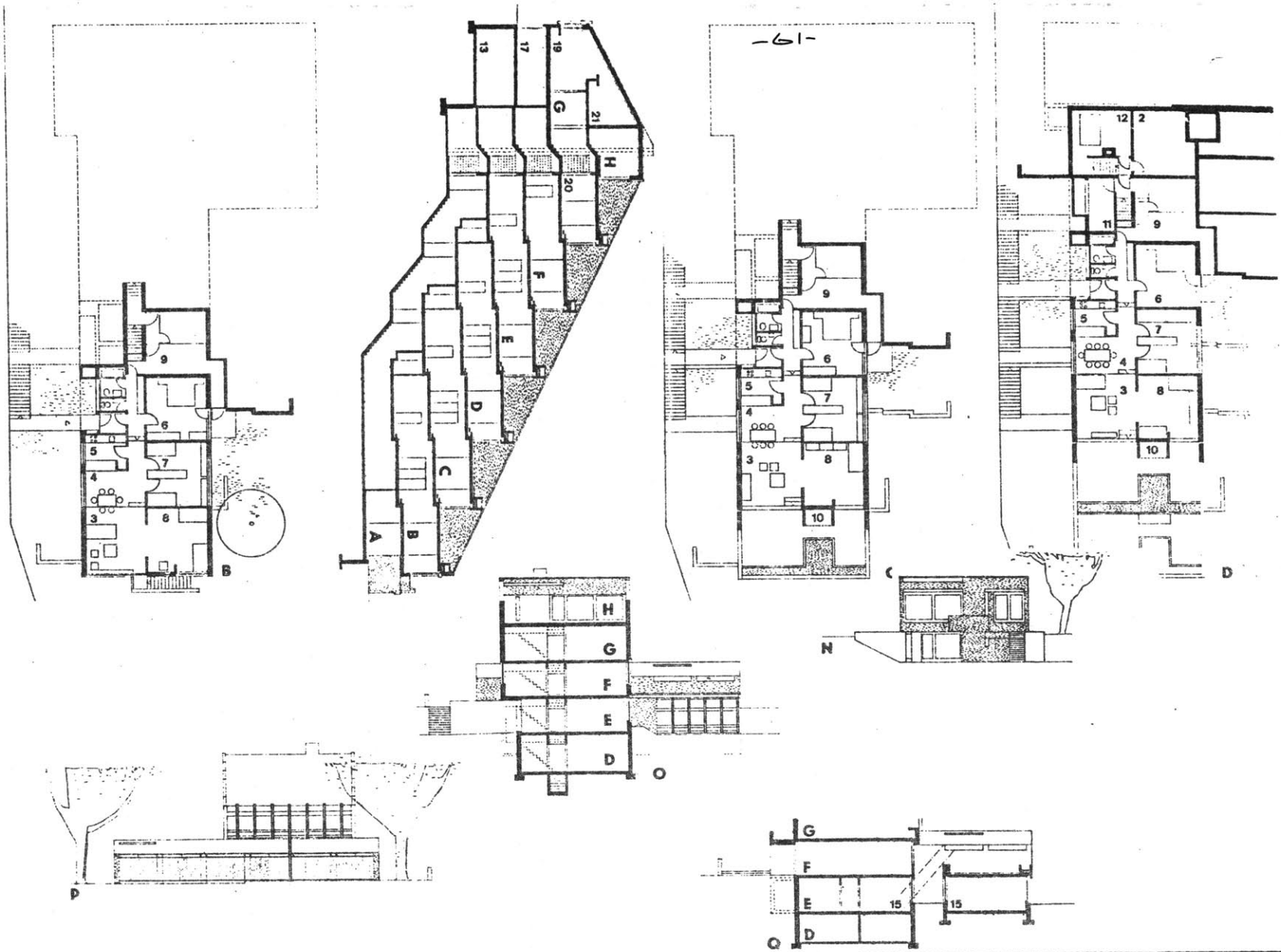

Project; Witikon Zürich Swisse  
 Architect; C Paillard P Leemann

26

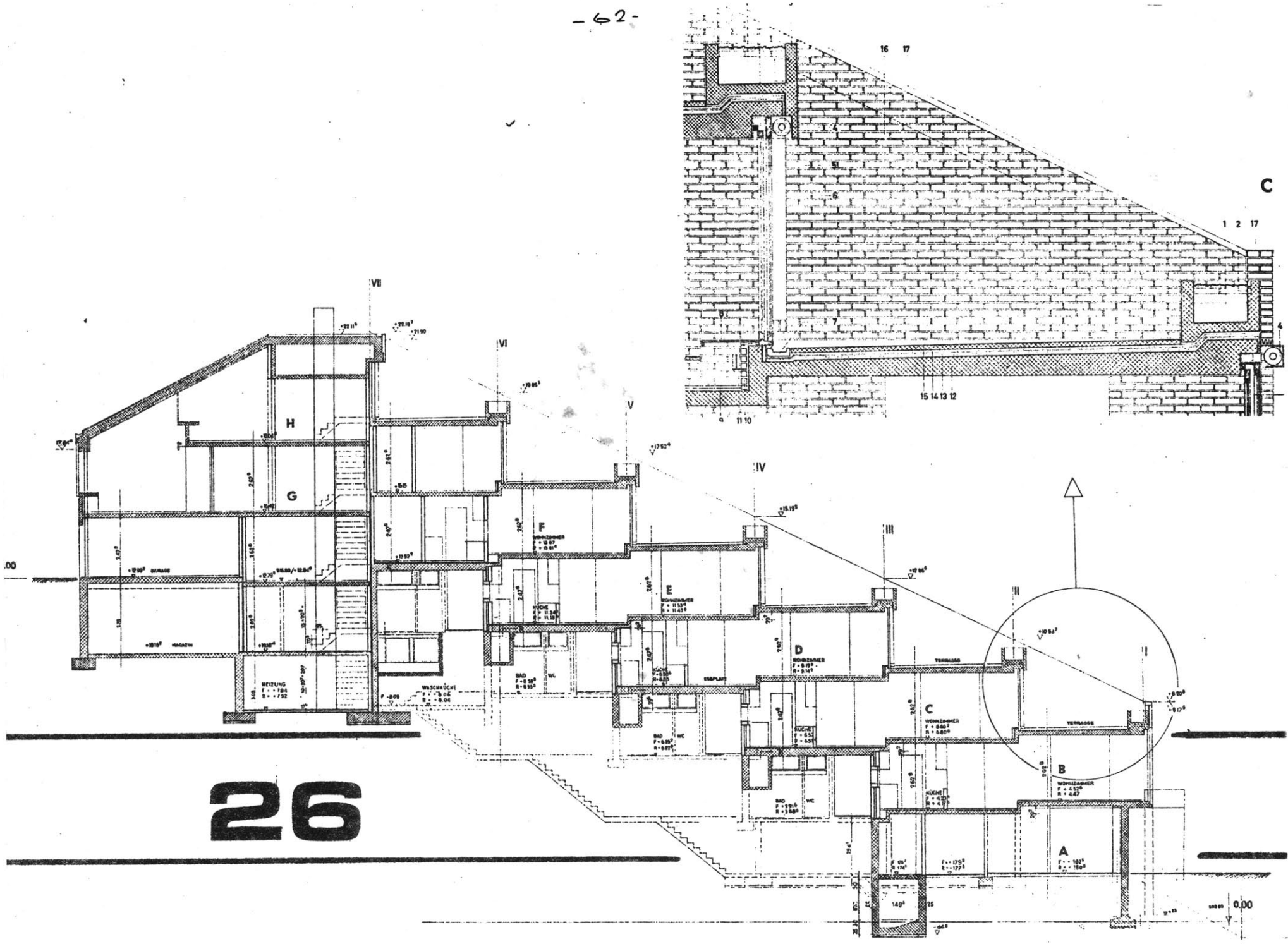

26

0.00

(2.1) SITE CONDITIONS PARAMETERS GROUP - GENERAL

This parameters group, which is among the first to be considered in the design process in various site conditions, is characterized by the fact that most of its elements are naturally set, without the human design and planning control. Other parameter groups can be or are controlled by human planning and design decisions such as: programatic parameters; design and technological parameters; etc. This fact puts the considerations of these parameters in the initial phases of many design processes, as they can narrow down the range of alternative design options. This is true particularly in situations where the site conditions are of extreme nature, as special climatic conditions or special topographic conditions such as slopes.

Site conditions in general and in the presence of extreme conditions in particular put some important

natural and contextual constraints on the planning and design alternatives which may be considered as 'adequate' or 'legitimate' in the specific site conditions. These constraints should not be conceived as final determinations of the planning and design alternatives. The nature of the site conditions considerations is of design guidelines or reference points rather than 'rules' (although they are frequently treated as design determinants). Various 'trade off's' can be assessed between these guidelines and other design factors as programmatic requirements or other design goals or technological constraints. The weight of this 'trade off' is increasing significantly as the planning and design scale is growing.

Two examples can be given here to illustrate the way by which the constraints which are implied by the site conditions can be over-weighted in these 'trade off' mechanisms:

- In the case of national housing policies level, the design and technical performance



standards are determined very often regardless of specific site conditions.

- In the case of production of industrialized building systems, the manufacturers are assuming that the building sites have the common landscape of their target market and their products are designed to meet these average conditions. The industrial repetition encourages many manufacturers to leave only a narrow design margin of open ended elements of the whole building system, which might accommodate specific site requirements, such as sloped sites.

With a closer look at the site conditions parameters group we find that they can be interrelated among themselves in a hierarchical order which reflects the weight and particular constraints of each parameter and its place in the design process. This hierarchical

order can be rearranged in every specific design to match the specific site conditions. For example; the parameter of the natural slope angle can be of primary importance in the case of a steep slope while in another case, the northerly slope orientation of the site may over-weight many other design parameters, by establishing dominance which effects many other parameters regardless of their usual importance in most other types of design process.

(2.2) THE SLOPES AND -

THE RELATION OF THE BUILDING TO THE NATURAL SLOPE.

Although these are two independent parameters it is preferred to discuss and analyze them together as they are closely related.

The examples of terrace houses which were studied were built on natural slopes with varying slope angles from minimum angles of  $5^{\circ}$  (8.7%) up to steep slopes of  $35^{\circ}$  (about 68% tilted site). The calculated average slope in the examples which were studied is  $21.5^{\circ}$ , which is only slightly higher than the average sloped sites with terrace houses which can be found in many countries.

The natural slope of the site was compared to the 'artificial slope' of the building, which is an imaginary line that passes through points in the building which appear in a repetitive pattern in the building's section (such as points as the meeting points of the

floors with the rear walls or the front walls, etc.). The 'building slope' does not have to conform to the natural slope angle of the site (there are examples of buildings which have steeper or more moderate slope angles than the sites they are located on). The 'building slope' may change within the building itself as in example no. 23 where the slopes in the front zone of the building are changed from the lower floors to the upper floors and the 'building slope' angle in the rear part of the building are different from those in its front.

The relation of the building to its natural sloped site is reflecting a basic component in the design concepts of building on slopes. The meeting of the building and the ground has been an important design issue throughout the history of architecture, reflecting different design-cultural attitudes and conceptions which questioned the meaning of the relations between the building and its natural-physical context. These

considerations also include an essential set of technical and design properties which should be maintained to comply with those general conceptions which were mentioned above. This consideration is important particularly in the design of terrace buildings, as the range of alternative solutions which will allow the basic need of proper functioning of the building is much more narrow than in other building types on flat sites. This decision has a larger range of implications in terrace buildings, as many other design parameters are dependent upon it. We can trace the consequences of this decision in many other parameters, and as this decision is clearly related to the angle of the natural slope we can consider these two parameters as the end of the thread which connects-relates the slope as an external reality which cannot be disregarded and the nature of the building which was generated by these conditions.

Two generic types of relations between the building and the natural slope were observed:

-(a) A building which follows gradiently the natural slope. Some of the examples where this solution was applied are: (1), (5), (6), (7), (8), (10). These solutions, although they are all of the same type, differ from one another in the level of interference with the natural site and in their details (i.e. some are partially dug into the ground, creating small terraces, some are detached from the ground by elevating them on piles and columns, some leave space between the building and the natural slope (ventilated or not), and some do not leave any space between the building and the ground, etc.).

-(b) The building slope is different from the natural slope (the 'building slope' line is dug into the ground). These buildings can be buried in the ground in the upper floors and the bottom floors are elevated on the surface or vice versa. Examples for

this building type are: (2), (3), (9), (11), and more.

Four 'slope types' were defined which may differ in the kind of solution to the building/ground which they enhance:

- Moderate slope - between  $6^{\circ}$  (10%) -  $14^{\circ}$  (25%).
- Medium slope between  $14^{\circ}$  (25%) -  $22^{\circ}$  (40%).
- Steep slope between  $22^{\circ}$  (40%) -  $45^{\circ}$  (100%).
- Slopes above  $45^{\circ}$  (100%).

The decision on the type of interface between the building and the natural slope can be based upon two parameters; the natural slope's angle, and the soil conditions (its fitness to accommodate a foundation system for the building). Other parameters of the site conditions may have some weight in these considerations, but it is generally of secondary importance. The weight of the slope angle and the soil conditions in determining the solution to the building/ground problem is an interchangeable variable which is dependent upon the extremity

of the conditions which they indicate. The importance of the natural slope angle with respect to various design considerations out-weighs the soil conditions (if they are not of extreme quality) as the slope becomes steeper.



No	PROJECT	NATURAL SLOPE	BUILDING SLOPE
(1)	STARNBERG GERMANY	18° (32%)	17° (30%)
(2)	HEIDELBERG/BOXBERG - GERMANY	13° (23.5%)	24° (45%)
(3)	VISP - SWISSE	16° (28.5%)	49° (115%)
(5)	OSLO - NORWAY	34° (68%)	34° (68%)
(6)	DARMSTADT - GERMANY	9° (16%)	9° (16%)
(7)	BALZERS - LIECHTENSTEIN	15° (26%)	15° (26%)
(8)	SIEDLUNG HALEN - SWISSE	12° (22%)	12° (22%)
(9)	PFaffenZIEL UNTERSIGGENTHAL SWISSE	23.5° (43%)	27° (50%)
(10)	MUHLEHALDE BRUGG - SWISSE	30° (58%)	30° (58%)
(11)	SIEDLUNG KAUTTUA - FINLAND	15° (26%)	21° (38%)
(13)	ORSELINA , TESSIN - SWISSE	23° (42.5%)	34° (68%)
(14)	ITACKA, N.Y. - U.S.A.	11° (20%)	11° (20%)
(15)	ZUG - SWISSE (a)	32° (62.5%)	32° (62.5%)
(15)	ZUG - SWISSE (b)	37° (75%)	50° (118.5%)
(16)	MAUREN - LIECHTENSTEIN		17.5° (31.5%)

(17)	SKONSTAVIK , STOCKHOLM - SWEEDEN	18.5° (33.5%)	18.5° (33.5%)
(18)	"BRUGGLIACHER", BADEN - SWISSE	15° (26%) - 20° (36%)	
(19)	PRATTEN - SWISSE	28° (53%)	28° (53%)
(20)	BACH FREIBACH - SWISSE		42° (90%)
(21)	ROQUERBRUNE - FRANCE		30° (58%)
(22)	GRENZACH - GERMANY	22° (40.5%)	22° (40.5%)
(23)	BAD GODESBERG , GUTACHTEN	25° (46,5%)	28° (53%)
(24)	FREIBURG- SWISSE		25° (46.5%)
(25)	HORENBERG	30° (58%)	30° (58%)

(2.3) THE SOIL CONDITIONS  
AND  
FOUNDATION SYSTEMS FOR TERRACE BUILDINGS.

This parameter deals with the natural soil conditions and their relations to the design and construction of buildings on slopes in general and their foundation systems in particular. This parameter is one of the parameters which specify the natural site conditions, and is closely related to the slope angle variables.

Many steep slope mountains are characterized by rocky soil conditions, while this statement cannot characterize with the same level of generality many moderate sloped hills and mountains (those which have rocky soil versus those which have not). This phenomenon can be explained by the influence of various types of erosion as the water and snow erosions or wind or thermic erosion. These various types of natural

erosion are more effective on the weak layers of the sloped ground. The weak layers of the ground are removed down-hills, and the hard and more stabilized ground layers are exposed. This process is more effective on steeper slopes where the eroded earth was quickly removed down-hills leaving the rocks exposed. Obviously the soil conditions have a special importance for the design of the foundation systems for buildings on slopes. The soil types of the slopes can vary between rocky soil and soft earth. As this study is concerned with the adequacy of the sloped ground to support terrace buildings, the soil conditions were divided into three categories;

(a)- Rocky soil; Although rocky soil qualities can differ from one site to another (in their homogeneity, their resistance to erosion, etc.), this soil type gives the best conditions for many foundation methods.

(b)- Stabilized soil; The soil is a mixture of rocks and soft earth (structured in layers or not), which gives fair conditions for proper design with conventional foundation methods.

(c)- Unsafe soil conditions; These soil conditions include either soft earth or soil types which have questionable or unpredicted qualities for supporting a building. There are very little quality 'half-tones' between soil conditions which are adequate for conventional foundation systems and those which are inadequate, as the planners prefer using wide safety margins in designing foundation systems on slopes.

These three categories of the soil conditions on slopes and the understanding of the natural erosion process of the slopes refer to the state of balance between the natural slopes and various external natural forces (as erosion) which is jeopardized by building on the slopes with inadequate handling of the slopes

external layers. As this balanced situation is often not realized it is disturbed by common practice of unnecessary excavation and leveling of the slopes into terraces, and by so doing weakening the soil structure on which the buildings are founded.

It should be noted here that the structural properties of the soil are examined with respect to the soil's capability to resist forces of two kinds; the vertical loads of the building, and the horizontal forces which might cause the sliding of the ground layers one on top of the other.

In the past, vernacular houses on slopes were built in small (and often lightweight) spatial elements on small terraces which required minimal intervention with the natural slope. This incremental building method reduced significantly the probability of land layers sliding and of whole buildings collapsing.

This approach was drastically changed in modern times as terraced houses were built in larger

scale, with the extensive intervention with the natural slopes. The change of the natural slope conditions is much more drastic than before, as it is believed that the modern construction and building technology might do the job better than the old methods and thus justify the more extensive intervention with the natural slopes. The technological solutions of the foundation systems on slopes were in most cases basically the same as those which were applied on flat sites. Very few foundation systems were developed especially for buildings on slopes; more of those should be developed to allow further development of terrace houses. Such foundation methods should increase the capacity of the slopes to support large building loads with minimum intervention with the natural slopes (for structural reasons as well as for ecological-environmental reasons).

(2.4)

NATURAL LIGHT AND VENTILATION IN TERRACE HOUSES.

The illumination and ventilation conditions in terrace houses are determined by the configuration of the envelope elements and their interrelations. Their physical definition indicates the specific problem of terrace houses as they have a rear edge which faces the slope, with very limited ventilation possibilities. The configurations of the envelopes elements in terrace houses can be divided into two categories:

(a) The case of the terrace houses which have either one dwelling unit per floor or two. These types are often applied on narrow lots. In this arrangement each dwelling unit has one main open front wall and one or two side walls which can be fully or partially open (depending on the site slope conditions and the amount of desired control by the users over the areas which are attached to the units at their sides.



(b) The case of the row-linear terrace houses, where the dwelling units have only one open faced wall to the front, as two flank side walls are dividing between neighboring units.

These conditions of natural ventilation and illumination create a dominant orientation of the dwelling units towards their front. That dominant orientation is among the main reasons for clear segmentation of the functions inside the dwelling units. As in many terrace houses the ventilation and the illumination problems are more acute than in other, more ordinary building types, they may require special consideration during the design process and possibly some additional investment of design and financial resources in providing some special technical solutions to these problems. Among these solutions are the following:

- 82 -

- Ventilating tunnels or ditches in the rear of the building [examples (6); (9); (11); (25)]. This solution may answer some isolation requirements of the building from the slope, to avoid dampness in the dwelling units.

- Ventilation and illumination through skylights [example (3)].

- Application of split-level design schemes which provide some possibilities for vertical cross ventilation and illumination solutions.

- Natural ventilation and illumination considerations can be integrated in the basic building design concept, encouraging curved and broken facade line, as by increasing the envelope length there are some better chances of improved ventilation and illumination inside the dwellings. Other possibilities can be invented and developed having these considerations in mind.

- In the cases where none of the solutions which provide natural ventilation and illumination are sufficient, some mechanical devices of ventilation can be considered, with proper provision of shafts and ducts system in the building. As it was indicated before, the factors of natural ventilation and illumination conditions are closely related to the functional setting possibilities inside the dwelling units. Planning and design decisions concerning these factors have to do with traditional-cultural norms and standards. Most of the examples which were studied and classified were built in western Europe; they reflect the low standards of natural ventilation and illumination provisions in the building which suit the local cold climate conditions. These standards are obviously different in other climates.

(2.5) CONNECTION TO THE URBAN CIRCULATION NETWORKS.

The need to provide easy access for pedestrians and vehicular circulation to the sloped sites is a consideration of special importance in the design of houses on slopes.

Generally, common planning standards of circulation networks on slopes for vehicular circulation as well as for pedestrian circulation, call for minimizing the use of steep slopes. In the case of vehicular circulation these standards are very rigid as most cars can take only a limited slope and maintain the safety of their passengers and the pedestrians who are around. Pedestrian paths networks on slopes are characterized by a much more flexible set of design standards as paths on slopes can combine horizontal paths with sloped paths and stairs paths. The limitations on the acceptable steepness of pedestrian paths are intended to provide a desired level of comfortable

pedestrian accessibility to and inside sloped sites. These standards of comfortable accessibility are determined by the combined effort of walking on horizontal paths plus the efforts of climbing in sloped paths or stairs. These increased walking uphill efforts can be measured by weighing them relatively to walking on flat horizontal paths. Different combinations of horizontal intervals between sloped/stairs paths allow a larger design flexibility for pedestrian circulation systems on slopes.

The examination of the classified examples of terrace houses on slopes indicates that pedestrian circulation networks are designed mostly on a small scale of 'on site' circulation patterns. These circulation patterns are often close ended systems which do not connect to other sites or relate to a clear pedestrian circulation master-plan. This situation

seems to be the result of the dispersed urban structure which characterizes many urban areas on hills or mountains. Pedestrian circulation networks in these places seem to be a by-product of the vehicular circulation roads systems, without special consideration of the different needs of pedestrian movement on slopes. Examples of urban developments on slopes which realized the special needs of pedestrians movement on slopes can be found in two contexts:

- In intensive development of contemporary high density urban centers on hills or mountains. The high density and development intensity may justify the extra investments of resources in developing special pedestrian circulation systems.

- In medieval towns on slopes where networks of pedestrian's alleys were built with the natural considerations of their special needs. The road systems for carriages and carts were built with planning

considerations which are basically those which are applied in the design of roads networks for motor vehicles today.

The following guidelines for planning circulation systems seem to be common in many circulation systems design on hilly or mountainous sites:

(a)- Main circulation arteries are located preferably in horizontal position (or as close to it as possible), on the ridges of the hills or in the valleys between them.

(b)- Secondary roads and paths are drawn in 'up-hills' positions. In steeper slopes, these roads and paths may climb the hills diagonally or in the steepest cases in curved snaky lines up-hills.

(c)- Vehicular circulation roads should not exceed the slope angle of  $8^{\circ}$  (15%) as average slope, and the maximum safety angle of about  $12^{\circ}$  (21%).

(d)- Pedestrian paths, if they combine slopes and stairs, should be designed with respect to the

kind of efforts which they require from different user groups, particularly elderly people and young children.

These functional guidelines may lead some designs to segregation of vehicular circulation from pedestrian circulation; they are not intended to imply that conclusion. Such a conclusion should be the result of a specific study of 'primary site conditions' as the slope, its shape, etc..



(2.6) SITE BOUNDARIES - GEOMETRIC FORM

AND

ORIENTATION OF SITE BOUNDARIES TO SLOPE DIRECTION.

A common design consideration which is particularly relevant in the design of terrace houses is the type of relation between the site's boundaries and the natural slope directions in its descriptive geometry sense. The various types of relations of this kind are dependent upon the following parameters:

- The geography of the site and its surrounding area (continuous mountains or hills ridges versus broken - dispersed lines of ridges and valleys).

- The roads and paths networks in the area (roads are located just on the ridges and in the valleys or a crosswise system of roads - on the hills ridges and in the valleys plus roads climbing straight uphill or in snaky lines, etc.).

Site boundaries and their relation to the natural slopes contour lines have the clearest implications on the following parameters:

- The possible building types which can be built on the specific sloped sites (row terrace buildings or one or two dwelling units per floor types, etc.).
- Preferred positioning of the buildings on the sites
- Possible on-site circulation patterns.

The generic site geometric forms which have been identified in the classification were: longitudinal sites; transversal sites (their long edges are perpendicular to the slope's contour lines); a circle segment (in both directions, relatively to the slope); and combinations of these basic elements.

A favorable lots division on slopes occurs mostly on longitudinal hills or mountains or on continuous ridges of hills where the roads are located on the

ridges or in the valleys. In that situation, a common lots division is nearest to regular; from the roads, which are the ridges or valley lines, up or down the hills. In this case the lots boundaries are parallel or perpendicular to the slopes contour lines and to the roads system. That kind of relation of the site boundaries to the natural slope allows the simplest regular design patterns (geometric) and thus might save many design and technical complications [examples (5); (8); (10); (13); (14)...].

As the natural slopes contour lines in hilly or mountainous areas are curved, the common lots division in these areas are frequently including circle sectors lots. These lots often imply a certain level of irregularity in the design schemes [examples (11); (23)], or it can be controlled by imposing a design grid on the site which allows adaptation to the irregular site conditions [as in example (7)].

Another possibility of relations between the site's contour lines and the natural site occurs where the slope contour lines are lined in a regular pattern but the lots division is inconsistent with that regularity. Often the reasons for this type of lots division is irrelevant to the regular design and planning considerations of buildings on slopes. In this situation the natural potential of the site to allow regular site conditions had been overlooked.

Another remark which can be made here concerns the site form geometric proportions. A common situation in this respect is that of transversal sites on sloped areas. That type of lots division seems to maximize the number of lots which are served by the expensive roads system on slopes and intensifies the utilization of urban infrastructure systems which are related to the roads systems. These narrow sites encourage the design of one or two units per floor types of buildings.

If the sites are divided the other way around, the sites are longitudinal, they encourage design of row terrace buildings (which take full advantage of that situation). Other types of terrace buildings are feasible in that situation although they might not take full advantage of it. If the slope contour lines are curved the row buildings can follow them with curved lines.

( 2.7) SITE CONDITIONS :

ORIENTATION TO SUN DIRECTION.

The orientation of the site towards the sun direction is one of the planning and design parameters which have a special importance in terrace houses on slopes. That importance is due to the presence of the prevailing slope conditions which dictate the orientation of the whole building as well as its spatial-functional elements. The extent to which that orientation converges with the preferred for residential purposes can determine the choice of the possible alternative in other design parameters. The consideration of the site orientation to the sun is gaining increasing importance in view of the diminishing energy resources situation. The solar energy can undoubtedly serve as an important energy source for heating and lighting. The relevance of these considerations is evident in cold climates as well as in arid

or tropical climates. In many West European countries the sloped sites which were developed in the urban areas, were facing the southern to west southern directions to allow maximum utilization of the natural light and heat of the sun. Many of the northern slopes (which are not facing the sun) were unattractive for residential uses and were thus left undeveloped, or were developed as green areas or for uses which are indifferent to their sun orientation. The reverse situation may occur in countries with hot arid or tropical climate. In these climatic conditions direct sun radiation is often undesired in houses in order to keep them shady and cool inside.

It should be noted here that even if the preferred sun orientation and the actual orientation of the site are in opposite directions, housing development on that site is still technically feasible. That feasibility is dependent upon the kind of 'economical trade-off' that the developer is willing

to make to cover the extra design and implementation costs to solve the unfavorable orientation problems. In many cases it can be assumed that the inferior sun orientation of the site was among the reasons to postpone the development until the time when the 'trade-off' will favor the development due to changing urban development trends or technological, economical future developments.



(2.8) TERRACE HOUSES - THE BUILDING TYPES.

The classification and the analysis study of the terrace houses identified the following three generic types of terrace houses on slopes:

- The longitudinal buildings; This type of buildings can also be identified as row terrace houses. According to the definition of this building type the length of the building is parallel to the slope contour lines. There are two sub-types of longitudinal terrace buildings; one with straight linear plan scheme and the second follows a curved or broken line scheme.

- The transversal buildings; These are terrace buildings which cross perpendicularly the slope contour lines. Two building sub-types can be distinguished here: the terrace houses with two dwelling units per floor, and the terrace building with a single dwelling unit per floor.

- The 'diagonal' terrace buildings; These are the terrace buildings which are developed in angle (except right angle) to the slope contour lines. Often each floor in these buildings is situated in two way set-back position in relation to the floors below and above. The distinctions between the sub-types can be the same as those which were applied in the transversal building type (one or two dwelling units per floor).

- Hybrid types of terrace buildings; These buildings can be identified as various combinations of other building types which were mentioned before. For the purposes of this study, only the primary types of terrace buildings were considered.

Each one of these terrace house types can be described as a result or generation of the various possibilities of the site condition parameter combinations. Such parameters as the site's geometric form, the orientation of the site to the slope direction

and the sun and wind directions have a primary importance in making the choice of the building type to be applied in a given site. Longitudinal sites are the most flexible in this respect as they allow the implementation of all the three generic building types of terrace houses on them. Transversal sites narrow down the preferred alternative solutions into transversal building types - with one or two dwelling units per floor. This choice might not be acceptable if the site's boundary lines geometry is transversal but the slope's contour lines are diagonal to the boundaries. This situation might encourage the choice of the diagonal terrace building type which can provide a better solution of the building's relation to the slopes as well as in some other respects. The same diagonal building type might be attractive in the case of the site whose boundary lines geometry is a circle's segment, as in most cases of a rational lots division

on slopes, these sites occur on the curved parts of the slopes. The latter sites allow the application of some transversal building types as well as some combinations of row buildings with transversal or diagonal buildings (given a large scale site). The different building types qualify differently with respect to the various site or programatic parameters such as the site's built coverage, the 'adequacy' of the building in relation to the specific site conditions (in technical details as well as in overall design issues as circulation and access patterns), or in the spatial standards which were applied in the building. In most rational design processes the decision concerning the building type will follow the considerations of the programatic requirements and the considerations of the specific site conditions.

In many designs the decision, concerning the choice of the building type to be applied is the turning

point from the planning and design considerations phase which precedes the actual design decisions, into the actual, specific design process. In the case of terrace buildings design, this decision is often made together with the decision concerning the general concept of the building relation to the sloped site. It is thus important and interesting to trace back and analyze the factors which lead into these decisions in various specific site conditions and programatic considerations.

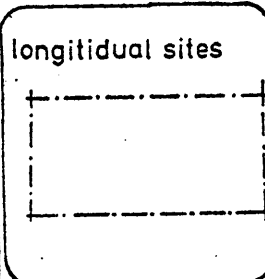
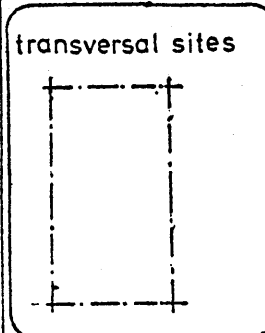
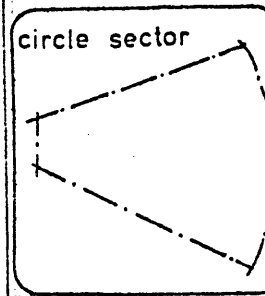
Q SLOPE ANGLE	EXAMPLES	C SITE BOUNDARIES - MORPHOLOGY	EXAMPLES
① moderate $6^{\circ}(10\%) - 14^{\circ}(25\%)$	① (1); (7); (8); (10); (13*); (14*); (15); (16); (17); (21); (18); (22); (25);	① longitudinal sites 	① (1); (7); (8); (10); (13*); (14*); (15); (17); (18); (21); (22); (25);
② medium $14^{\circ}(25\%) - 22^{\circ}(40\%)$	② (3); (5); (6); (9); (19); (24);	② transversal sites 	② (3); (5); (6); (9); (19); (24) (24);
③ steep $22^{\circ}(40\%) - 45^{\circ}(100\%)$	③ (11);	③ circle sector 	③ (11);
④ above $45^{\circ}$	④ (2 (1+3)); (4 (1+3)); *the site is much larger for a single building development	④ combination of the other variants	④ (2 (1+3)); (4 (1+3)); * The site is a large site which can accommodate a number of buildings.

**d** SLOPE CONTOUR LINES DIRECTION

**EXAMPLES**

①

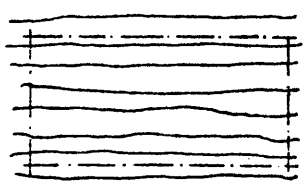

parallel to the site boundaries

①  
 (1); (3); (5); (7); (8);  
 (10); (13); (14); (15);  
 (17); (22); (24); (25);

②

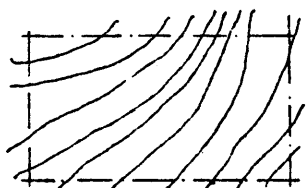

diagonal

②  
 (6); (16);

③

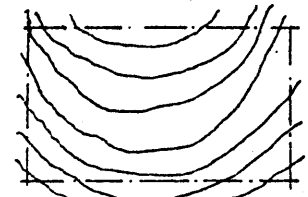

curved

③  
 (11); (26);

④

combination of the other variants

④  
 (2(I+3)); (4(I+3));  
 (18(I+3));

\*in the examples where explicit info. was not available, the slope direction was estimated by examining the pictures of the building.

**e** ORIENTATION TO THE SUN

**EXAMPLES**

①

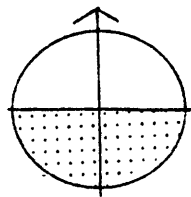

acceptable

①  
 (2); (3); (4); (5); (7); (8);  
 (9); (11); (14); (15); (17);  
 (19); (23); (22); (18);

②

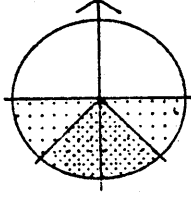

preferred

②  
 (1); (6); (10); (13); (26);  
 (21); (22); (23);

③

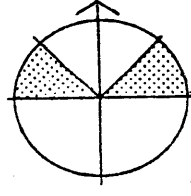

inferior

③  
 (15);

④

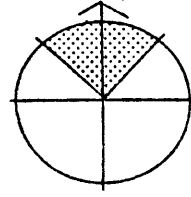

undesired

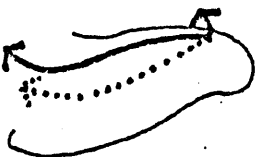
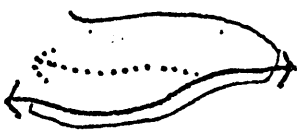
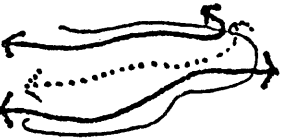
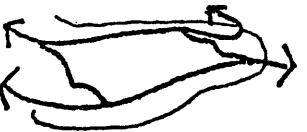
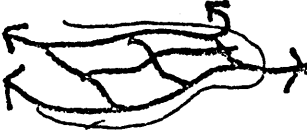
B		
f	CONNECTION TO URBAN ROADS & TRANS NETWK	EXAMPLES
①		① (16); (13); (14); (21); (23);
②		② (1); (3); (5); (9); (10); (17); (19); (22); (24)
③		③ (2); (6); (8); (15);
④		④ (11); (18);
⑤		⑤ (4); (7); (12);
⑥	combination of the other variants	

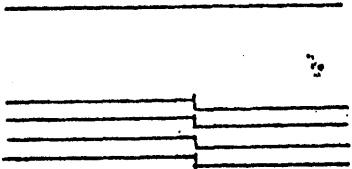
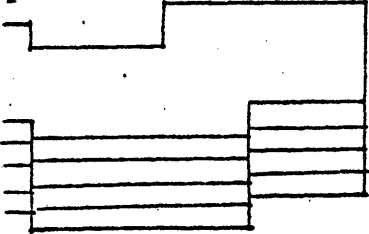
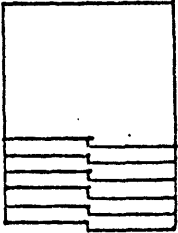
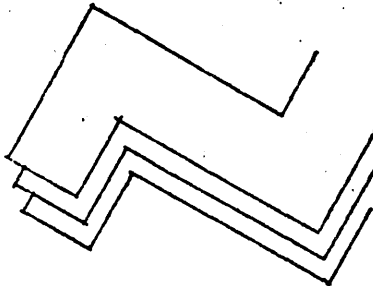
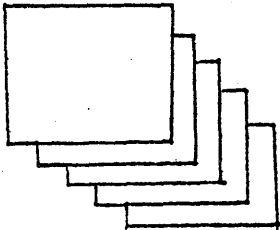
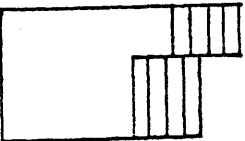
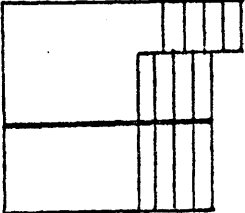

THE BUILDING TYPE			
9	GENERIC TYPES	SUB-TYPES	EXAMPLES
①			<u>(1.1)</u> (4); (7); (8); (13); (17); (18); (21); (22);
②			<u>(2.3)</u> (5); (9); (10); (11); (20); (24); (25);
③			<u>(2.4)</u> (2); (3); (12);
④	combination of the other variants		<u>(3.3)</u> (19);
			<u>(4)</u> <u>(1.1+2.4)</u> (4); (14); (21); (23);

**h** SCHEMATIC CONCEPT OF THE BUILDING RELATION TO THE NATURAL SLOPE

**EXAMPLES**

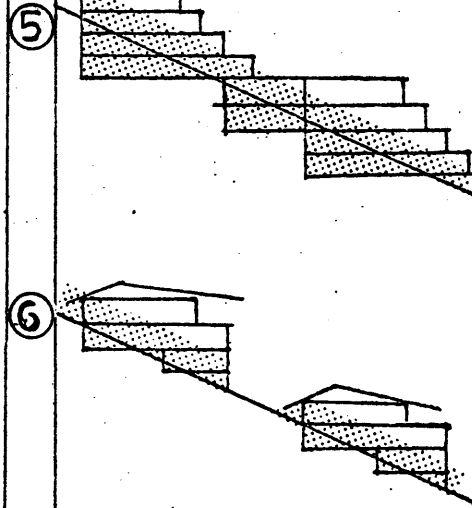
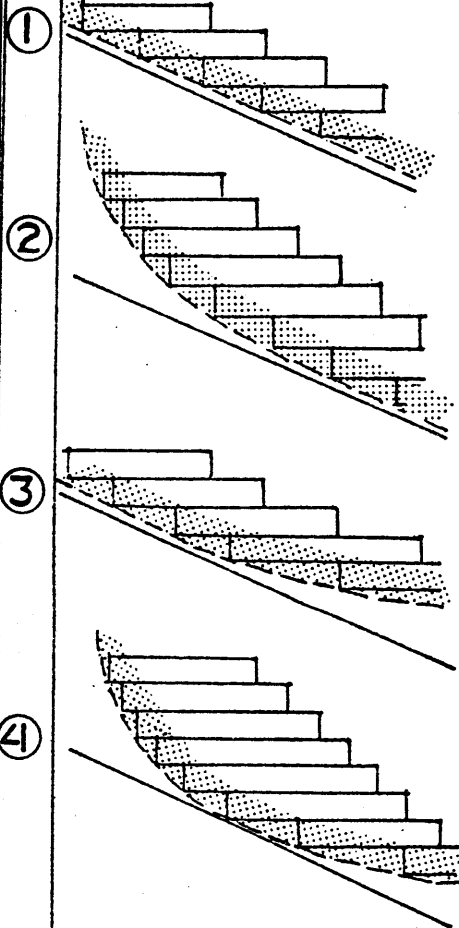

7 combination of the other variants

8 other solutions

**①**  
(1); (4); (5); (7); (8); (9);  
(10); (12); (14); (15); (19);  
(21); (22);

**③**  
(24);

**④**  
(23);

**⑤**  
(3); (11); (13); (17); (25);

**⑥**  
(6);

**⑧**  
(2); (15);

(3.0) A PROPOSAL FOR A ZONING SYSTEM FOR TERRACE HOUSES.

GENERAL

Terrace houses as a distinct building type, have some specific requirements for an appropriate zoning system which might help in rationalizing the planning and design process of this building type. A zoning system which is in essence a rational ordering system of various building design elements as the functional spaces (open and built); some building systems as the structural and infra structural system or the infill elements system. Such a zoning system is needed for terrace houses as they pose some difficult orientation problems of those elements with respect to the natural slope, the sun etc).

The method of forming this proposed zoning system is continuous to the classification method applied before. Some observations which were made throughout the classification study were generalized and integrated in establishing this zoning system. Also were included some remarks which were made in the analysis, concerning the following distinctive properties of terrace houses;

- The fragmented nature of terrace buildings, these buildings can be conceived as an agglomeration of 'independent' elements which are the various building floors with their different situation in the building with respect to some external elements as the slope.

- The set of design problems which are created by the 'set back' situation of the floors.

- The analysis of the various classification parameters.

These remarks can be helpful in generalizing some conclusions, concerning the ordering systems of the various building elements. These observations lead to the identification of two main zoning systems for terrace houses;

- (a) The diagonal (sections) zones ; These zones define three diagonal zones in the building's sections. Each one of these zones contains a set of building elements which characterize the specific diagonal zone and the set of problems which it generates. The diagonal zones help to determine the relations between the various building floors.

- (b) The horizontal zoning systems ; These zoning systems

are particularly effective in designing the two dimensional floor layouts (after the coordination between the different floors common building systems with the diagonal zoning system). Two horizontal zoning systems were observed; the primary zoning which is parallel to the slope contour lines, and the segmental zoning which is perpendicular to the slope.

These two main zoning systems constitute together a design framework which is specific to the design and planning problems of terrace houses.

(3.1) THE DIAGONAL ZONING SYSTEM

---

The elements of the diagonal zoning system are defined in the building sections. These elements are three main diagonal zones which contain three distinctive sets of building elements which are related to the three possible situations in terrace buildings.

(a) The front zone ; This zone includes the terrace areas of the building and can be related to the following design issues;

- The terraces use; to what extent are the terraces used, by who and for what purposes.
- The growth possibilities of the dwelling units on the terraces; design and technological-execution.
- Privacy control; the mechanisms and the elements which serve this purpose.
- Technical problems; water drainage systems, thermal and water insulation problems etc,.

(b) The main - functional building zone ; This zone contains most of the residential activities which are accommodated inside the building. The design problems which

are particularly relevant in this diagonal zone are;

- The basic functional patterns which are frequently applied in terrace houses (with all the specific orientation problems involved).
- The relations of the structural building systems and the characteristic functional patterns, (the constraints which they put on each other).
- The effect of the 'set back' situation on the design of the infra structural systems.

(c) The rear zone ; This building zone contains all the elements which relate the building to the natural slope. This zone is functioning as a distinct building element which acts as a membrane although its main functional assignments may be for other purposes (mostly service areas). The design issues which are relevant for consideration in this context are the following;

- The general treatment of the natural slope; leaving the natural slope intact (by elevating the building above the ground), rearrangement of the natural slope into leveled terraces (by excavating or land filling or by combination of both etc.), changing

radically the natural slope conditions (large scale excavations and land filling etc,).

- The isolation techniques of the building from the ground; -technical solutions (water proofing, thermal isolation, preventing the rooting of the surrounding flora in the rear walls of the building.

- Functional solutions; allocating the functional areas in the rear zone to functions which are indiffererent to the implications of such location, or by using non-functional spaces for isolation purposes, or by combining the two possibilities to give a double insulation results.

The building elements which are assigned to each of the diagonal zones are part of the design solution of each specific floor layout. This definition is close to the concept of terrace houses as stratal structures; both definitions express the method of independent assignment of relevant design solution to each floor in the building, matching it's specific requirements. The diagonal zones are serving as a design tool to coordinate and adjust the various independent





design alternatives, assigned to each floor as 'adequate', without imposing the same solution, for the continuity's sake on other building floors. This design problem implies the nature of the diagonal zones as a rational set of 'rules' for positioning and dimensioning the building elements of terrace houses as functional spaces, infra structural systems structural elements, land development etc,.

PRELIMINARY DESIGN DECISIONS

**k** THE REAR ZONE AND BUFFER ELEMENTS (ALT.)

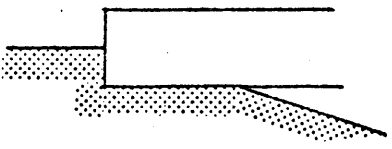
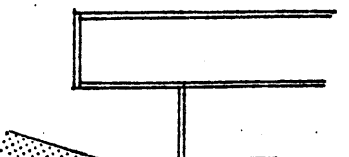
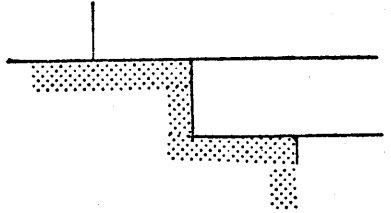
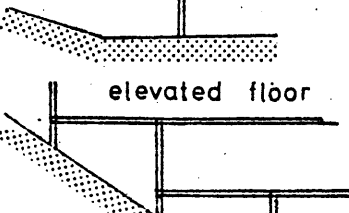
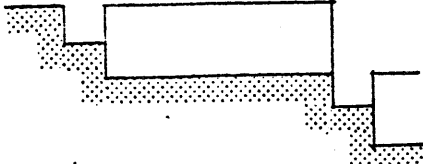
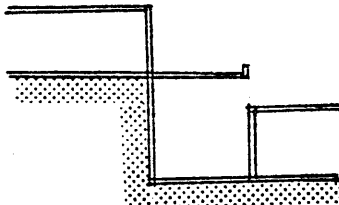
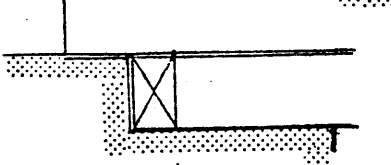
ELEMENTS      EXAMPLES

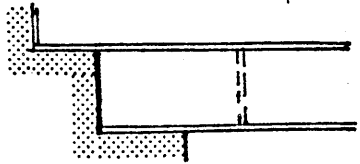
①		⑥		<p>① (6); (15); (12);</p>
②		⑦	 <p>elevated floor</p>	<p>② (7); (9); (12); (17);</p>
③		⑧		<p>③ (6); (24);</p>
④	 <p>'buffer' margin</p>	⑨		<p>④ (1); (2); (3); (8); (9); (10); (11); (13); (15); (18); (20);</p>
⑤	 <p>buffer rear zone (functional space)</p>			<p>⑤ (1); (2); (3); (4); (5); (7); (8); (9); (10); (11); (13); (15); (19); (20); (21); (22); (23); (24);</p>
				<p>⑥ (2); (3); (4); (5); (8); (13); (17); (18); (19); (23); (24);</p>
				<p>⑦ (5); (14); (17); (19); (20); (25);</p>
				<p>⑧ (7);</p>
				<p>⑨ parking space (23); (25); (18);</p>

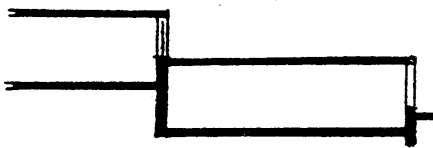
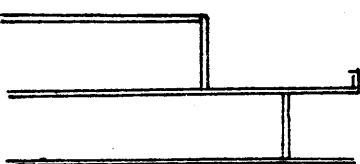
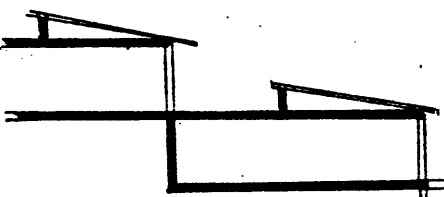
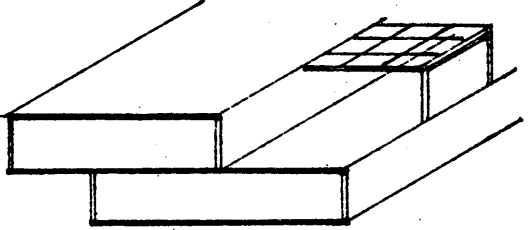
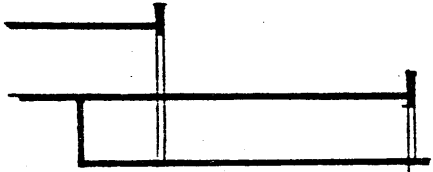
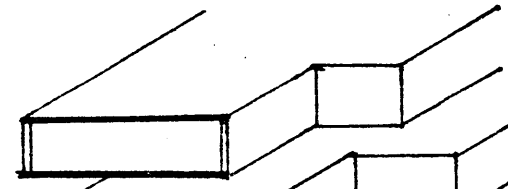
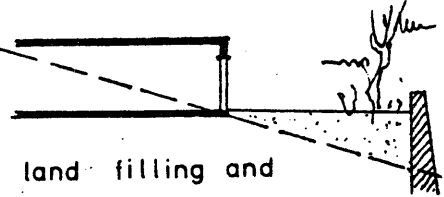
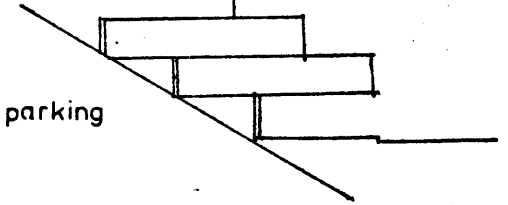
L THE FRONT-TERRACES ZONE	ELEMENTS	EXAMPLES
<p>①</p>  <p>not usable</p>	<p>⑤</p> 	<p>①</p> <p>(1); (14); (16);</p>
<p>②</p>  <p>partially used</p>	<p>⑥</p>  <p>partially roofed terrace</p>	<p>②</p> <p>(9); (11); (17); (21); (22);</p> <p>③</p> <p>(4); (5); (8); (13); (15); (18); (19); (20); (24); (25);</p>
<p>③</p>  <p>fully used</p>	<p>⑦</p>  <p>patio terraces</p>	<p>④</p> <p>(6); (7); (8);</p> <p>⑤</p> <p>(7); (22);</p>
<p>④</p>  <p>land filling and retaining walls</p>	<p>⑧</p>  <p>parking</p>	<p>⑥</p> <p>(10); (11);</p> <p>⑦</p> <p>(2); (3); (4); (7); (10); (12); (14); (16); (17); (18); (21); (23); (24);</p>
	<p>⑨</p>	<p>⑧</p> <p>(1); (2); (5); (9); (13); (15); (19); (24);</p> <p>⑨</p> <p>(8);</p>

(3.2) THE HORIZONTAL ZONING SYSTEMS

---

The observations which were made throughout the classification of terrace houses revealed some common types of segregation of various building elements as functional spaces, infra structural elements etc,. The analysis of these segregation types suggests that they were generated by the special sloped site conditions of the terrace houses. These segregation methods seem to be related to the distance and the position of the various building elements with respect to the slopes, the external walls and front terraces. The segregation of the building elements in relation to the external walls (as they enjoy natural sun light and ventilation), is common in many housing types, the special relation to the rear area which faces the slope is particular to terrace houses. These segregation methods were generalized as two complementary zoning systems; one, main system, parallel to the slope contour lines and the other, the secondary, which is perpendicular to the slope. The two systems act together in ordering the various elements in the building.

(3.2.1) THE HORIZONTAL ZONING SYSTEMS - PARALLEL TO THE SLOPE

This zoning system seems to have primary importance as it converges with the natural direction for development on the slopes in the urban scale as well as in the site planning and the building scales. The zoning system parallel to the slope translates the various requirements of planning and building on slopes into actual design decisions in a most direct way. This horizontal zoning system defines three main zones and the margins between them.

- THE REAR ZONE (R) : This zone is the closest to the natural slope. This zone is acting not only as an ordering tool but also defines a zone in the rear of the building which has an isolation function of the building from the ground. This is an additional function of the spaces which are in this zone, besides their main assigned function in the building. Because of that characteristic of the rear zone, the functions which are assigned to it are secondary functions in the dwelling unit (not main living functions), including kitchens, bathrooms, work rooms, storage and hobbies rooms. If there is no 'buffer' margin between the rear zone and the slope, a special

treatment should be given to the rear wall in this zone to enable it to function as isolating zone.

- THE LIVING SPACE ZONES (L) : These zones accommodate the main living functions in the dwelling unit which include the main living (family) rooms, and the bedrooms (the master bedroom and the children's). In many cases, functions which can be assigned to the rear zone (R), can be located in these living zones. Two sub-types of living zones can be observed and defined; a living zone which is a single living zone in the dwelling unit and thus acts as a more 'exclusive zone, and living zones of multiple living zones system which accommodate other functions including (most common) some terraces, patio elements. The living zones are always located in front area in the dwelling unit, enjoying direct sun light and natural ventilation, and an open view ahead.

- THE TERRACE ZONE (T) : This zone is a unique feature of the terrace houses. In most of the cases the terraces are the results of the building floors 'set back' one on top of the other. The observations of the terrace uses indicate a

large variety of uses ranging from un used non-functional open spaces (as tilted roofs) through recreational uses for the whole family, roof gardens, to fully used spaces which were added to the dwelling units behind the terraces. If the growth possibilities on the terrace are legal and made with agreements among the building users the terraces can be designed as an additional living zones (∞). If the expansion on the terraces is illegal, the added spaces will probably start modestly as small storage areas which will develop in the future into full living spaces. Another terraces use vanished in modern terrace houses and is the semi-public and semi private uses as small shops, circulation areas and recreational areas. It seems that with a proper technical design solutions, some of these ambiguous activities can be revitalized.

#### THE MARGINS :

These are the areas which separate between the zones at the building edges and the outside and between the building zones themselves. The basic rules which are applied in the use

of the margins, as well as in most of the zones rules, are similar to the 'rules' which were developed within the S.A.R design methodology as described in "VARIATIONS The Systematic Design of Supports". The spaces which are located in the zones are terminated in the margins. The margins provide the space which is needed to allow some design flexibility and to accommodate various interface elements between various building systems. In terrace houses, some margins may assume an additional role mainly as unused 'buffer' margins which isolate the building from the ground, or for circulation purposes inside the dwelling units. The main margins are;

- The BUFFER margin (B) ; This margin is located behind the rear zone (R), and serves as additional isolation band between the main functional spaces and the natural slope. Like the rear zone this buffer margin prevents the penetration of moisture into the building. This unfunctional space is sometime used as a duct for various infra structural systems. The spaces in the rear zone cannot be extended into this buffer margin.



- THE CIRCULATION MARGIN (C) : This margin resembles to a large extent the ( $\beta$ ) zone of the S.A.R. design method although the special design patterns of terrace houses do not allow it's definition as a building zone. This margin is used mainly for circulation area (mostly only in part of it's length). This margin accomodates also some closets area.

- THE ( $\alpha, \tau$ ) MARGIN : Generally this is the marginal area which accomodates the membrane between the built spaces and the terrace open spaces. This margin allows the veriety in the design treatment of that membrane (the facad,).





These zones and margins which constitute the zoning system which is parallel to the slope contour lines can be combined in different ways. The different combinations represent either existing buildings for classification or various analysis purposes, or they can be applied as design tools applied in the process of generating new design solutions to various site conditions or any external conditions.

The observations of the classified examples of terrace houses identified two generic zoning systems parallel to slopes;

- Single living zone (X) system ; This zoning system is generally constituted by a combination of a rear zone (R), a circulation margin (C), one living zone (X), and a terrace zone in front.

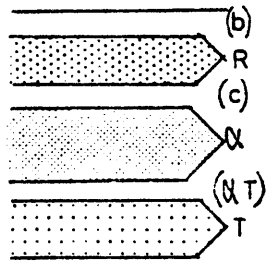
- Double living (X) zones system ; This zoning system combines a rear (R) zone, a circulation (C) margin, with two living (X) zones and a terraces zone (T) in front, (an additional (X1,X2) margin can be applied between the living zones). The front living zone (X1) is mostly used for primary living functions as family room, while the inner living zone can be partially used for secondary functions. In all cases, the external living zone is accomodating on most of it's area a patio which provides light and ventilation to the inner living zone.

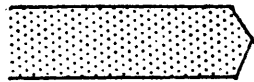
THE ZONING SYSTEMS - HORIZONTAL

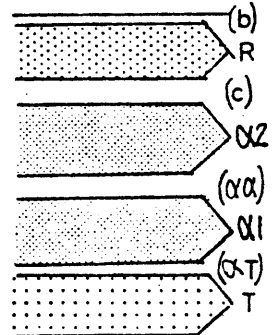
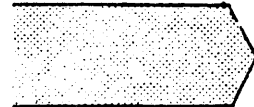
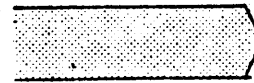
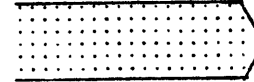
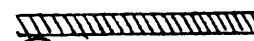
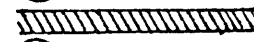
i	GENERIC - PARALLEL TO SLOPE - ZONING SYS.	ELEMENTS:	EXAMPLES	
①	 <p>single (<math>\alpha</math>) zoning system</p>	<p>1  (b) - buffer margin</p> <p>2  (R) rear zone</p> <p>3  (c) 'circulation' margin</p>	<p>(1) - ② (1.2.5.7.5)</p> <p>(2) - ② (1.2.3.5.5)</p> <p>(3) - ② (1.2.3.5.5)</p> <p>(5) - ① (2.3.4.8.6)</p> <p>(6) - ① (1.2.3.4)</p> <p>(7) - ② (2.3.5.7.5)</p>	<p>(20) - ③ (1.2.3.4.6)</p> <p>(21) - ① (2.3.5.7.5)</p> <p>(22) - ① (1.2.3.4)</p> <p>(23) - ② (2.3.5.7.5)</p> <p>(24) - ② (2.3.5.7.5.6)</p> <p>(25) - ③ (5.7.5.6)</p>
②	<p>double (<math>\alpha</math>) zoning system</p> 	<p>4  (<math>\alpha</math>) - zone</p> <p>5  (<math>\alpha</math>)(<math>\alpha</math>) - zones</p> <p>6  (T) - terraces zone</p>	<p>(9) - ② (1.1.2.3.5.7.5)</p> <p>(10) - ② (2.3.5.7.5)</p> <p>(11) - ② (2.3.5.7.5.6)</p> <p>(12) - ② (5.7.5)</p> <p>(13) - ① (1.2.3.4.8.6)</p> <p>(14) - ② (2.3.5.7.5)</p> <p>(15) - ① (1.2.3.4.6)</p> <p>(16) - ③ (1.2.3.5.7.5)</p> <p>(17) - ③ (5.7.5.5) (2.3.4)*</p> <p>(18) - ② (1.2.3.5.7.5.6)</p>	
③	<p>other zoning systems</p>	<p>7  (<math>\alpha</math>) - margin</p> <p>8  (<math>\alpha</math>T) - margin</p>	<p>(19) - ③ (2.3.5.5.6)</p>	

(3.2.2) HORIZONTAL ZONING SYSTEMS - SEGMENTAL (TRANSVERSAL) ZONING

These horizontal zoning of the terrace houses are perpendicular to the slope contour lines. The segmental zoning is particularly relevant in the transversal buildings and the diagonal terrace houses, although it can be helpful in the design of row terrace buildings. The significant role of the segmental zoning in diagonal and transversal buildings stems from the fact that as there are only one or two dwelling units per floor in these buildings each dwelling unit has two or even three edges with the natural illumination and ventilation which they provide. This situation, where there are two or three favourable orientations in each dwelling unit create a different segmentation system of the building elements which is essentially perpendicular to the slope direction. The segmental zoning system is recognizing and formalizing that natural trend which is characteristic not only in terrace buildings.

The establishment of the segmental zoning system is following the formulation of the horizontal zoning -parallel

to the slope. The latter zoning system plays a major role in establishing the basic concept of many buildings with respect to the schematic and detailed relations of the building to the natural slope (with the preliminary segregation of the building elements accordingly).

The two zoning systems create an orthogonal chequered board zoning framework. In that combined zoning system, each spatial element is identified (by the generic characteristics of the two perpendicular zones which converge in it).

The structural system which is employed in each building has a determinant role in choosing the segmental zoning system and its elements, this deterministic function can be working in the other direction if the decisions order is changed. In the first case the process of establishing the two zoning systems can be divided into two stages; in the first only the zoning system - parallel to the slope is determined, the second stage will enter the design process only after it had proceeded into some decisions including a preliminary allocation of building elements in the parallel zoning system,

and the assignment of a basic structural system to the building. The second stage will involve the establishment of a segmental zoning system after considering the conditions which were created by the former decisions. The functions which were assigned before to the 'parallel' zoning system can be reshuffled in the same zone, changing orientation only.

The segmental zoning system includes the following elements in various combinations;

- Internal zones-(I) segments ; These are the segments which have access to the outside (with natural light and ventilation ) only in the front. If primary functional elements ( living rooms, bedrooms) are located in segments of that kind, they will be located in the front 'chequer'.

The ( I ) segments can be sub-devided into;

(I;1)- An internal segment with natural ventilation and access to daylight only in the front.

(I;2)- An internal segment which has access to daylight only in the front plus natural or mechanical ventilation on it's rear side.

Segments with a side facad ( E ); These are the segments which have a front facad (facing the terrace) and one or even two side facad, providing direct natural light and ventilation. These segments can accomodate living functions as the (X) zones in the 'parallel' zoning system.

(E:1)- A building segment which has front and side facads providing natural light and ventilation with blank rear.







(E;2)- A building segment which has front and side facads providing natural light and ventilation plus an open rear which can provide additional natural or mechanical ventilation to the rear zone of the dwelling unit.

THE MARGINS : Two margin types are applied in the segmental zoning systems. These two types are different in their 'transparancy', or the extent to which they allow the penetration of the building elements on their sides through them.

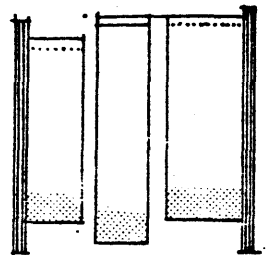
The 'open' margin ; This margin may vary in its width as it passes across the dwelling unit. It can accomodate circulation areas, closets or ducts, the spaces on its sides can stretch over this margin to other building segments.

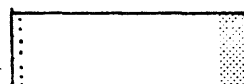
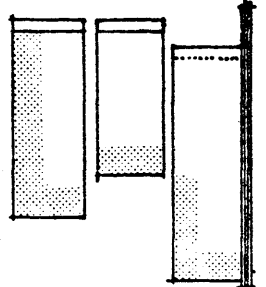
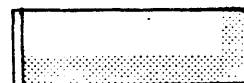
The 'blank' margins ; These are margins with fixed lines which in many cases indicate the location and position of the structural systems of the building, as load bearing walls systems or the infra structural systems (mainly the 'wet' cores. In many cases these margins are deviding between neighbouring dwelling units.

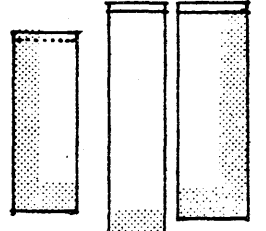
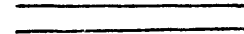

j	SEGMENTAL ZONING	ELEMENTS :	EXAMPLES	
①	 <p>segmental zoning in a row building</p>	<p>.1 </p> <p>① internal segment unventilated rear</p> <p>2 </p> <p>① internal segment ventilated rear</p>	<p>(1) <del>③</del> (3.5.1.5.3)</p> <p>(2) <del>②</del> (3.5.1.1.1.6)</p> <p>(3) <del>②</del> (3.5.1.5.3.6)</p> <p>(5) <del>③</del> (3.5.1.1.3)</p> <p>(6) <del>③</del> (3.5.1.3)</p> <p>(7) <del>①</del> (2.5.2)</p> <p>(9) <del>③</del> (3.5.1.5.3)</p>	<p>(20) <del>④</del> (4.5.1.5.4)</p> <p>(21) <del>②</del> (3.5.1)</p> <p>(22) <del>②</del> (4.5.2.2.6) (3.1.1.6)*</p> <p>(23) <del>②</del> (3.5.1.1.1)</p> <p>(24) <del>③</del> (3.1.1.1.3)</p> <p>(25) <del>③</del> (3.5.1.1.3)</p>
②	 <p>two dwelling units per floor</p>	<p>3 </p> <p>Ⓔ side seg. unvent. rear</p> <p>4 </p> <p>Ⓔ side seg. vent. rear</p>	<p>(10) <del>③</del> (3.1.1.1.3)</p> <p>(11) <del>③</del> (4.5.4)</p> <p>(12) <del>②</del> (3.5.1.6)</p> <p>(13) <del>①</del> (2.5.2)</p> <p>(14) <del>②</del> (3.5.1)</p>	<p>*duplex apartments</p>
③	 <p>one d/u per floor</p>	<p>5 </p> <p>open margin</p> <p>6 </p> <p>closed margin</p>	<p>(15) <del>③</del> (4.5.2.5.2.5.4)</p> <p>(16) <del>①</del> (2.5.2)</p> <p>(17) <del>②</del> (4.2.2.4.6)</p> <p>(18) <del>②</del> (3.5.1.1.1.1.6)</p>	
④	<p>other zoning sys.</p>	<p>.7 other elements</p>	<p>(19) <del>④</del> 'diagonal'</p>	

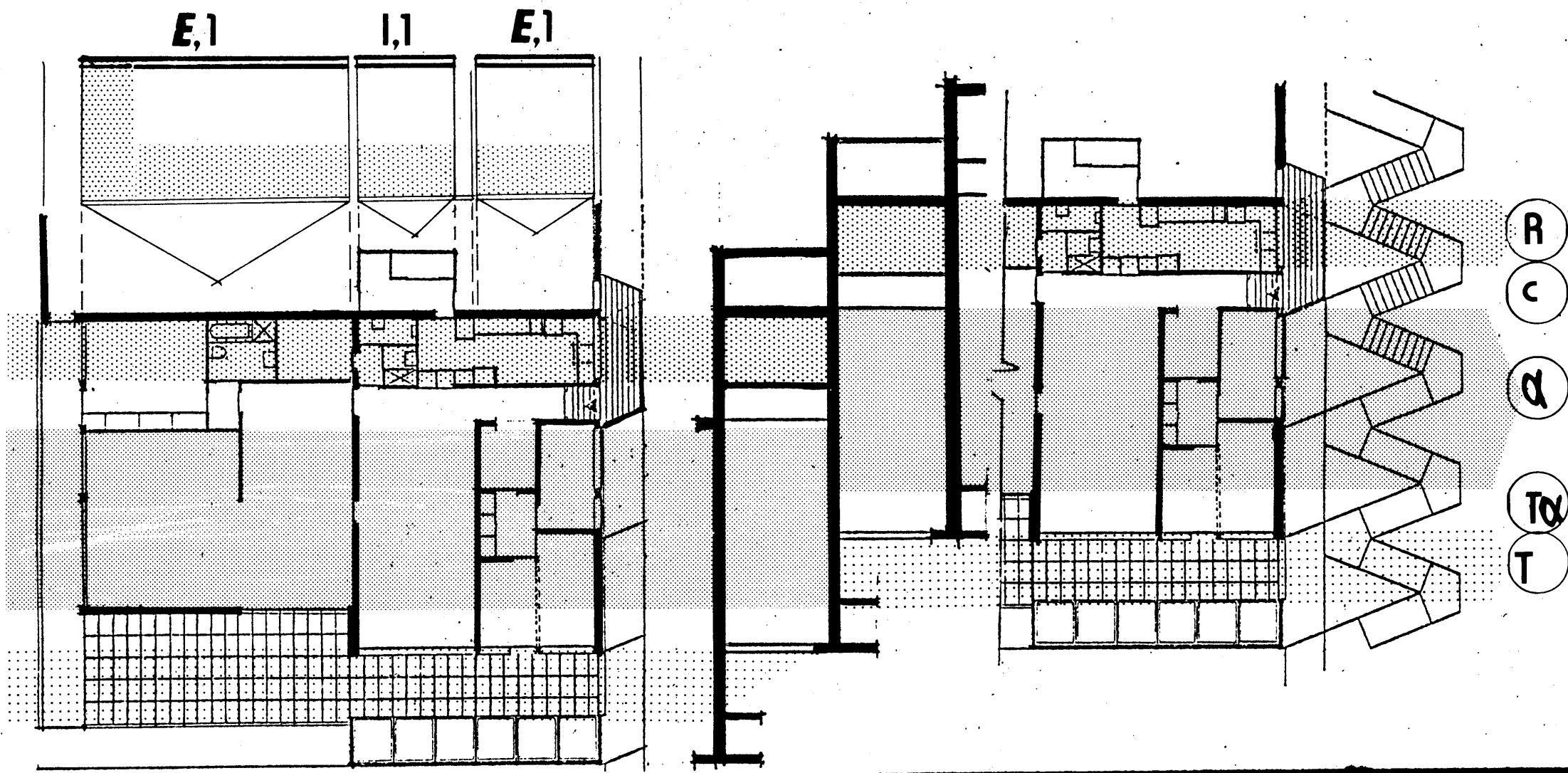

Project; Ullernaasen Oslo  
Architect; Anne-Tinne & Mogens Friis

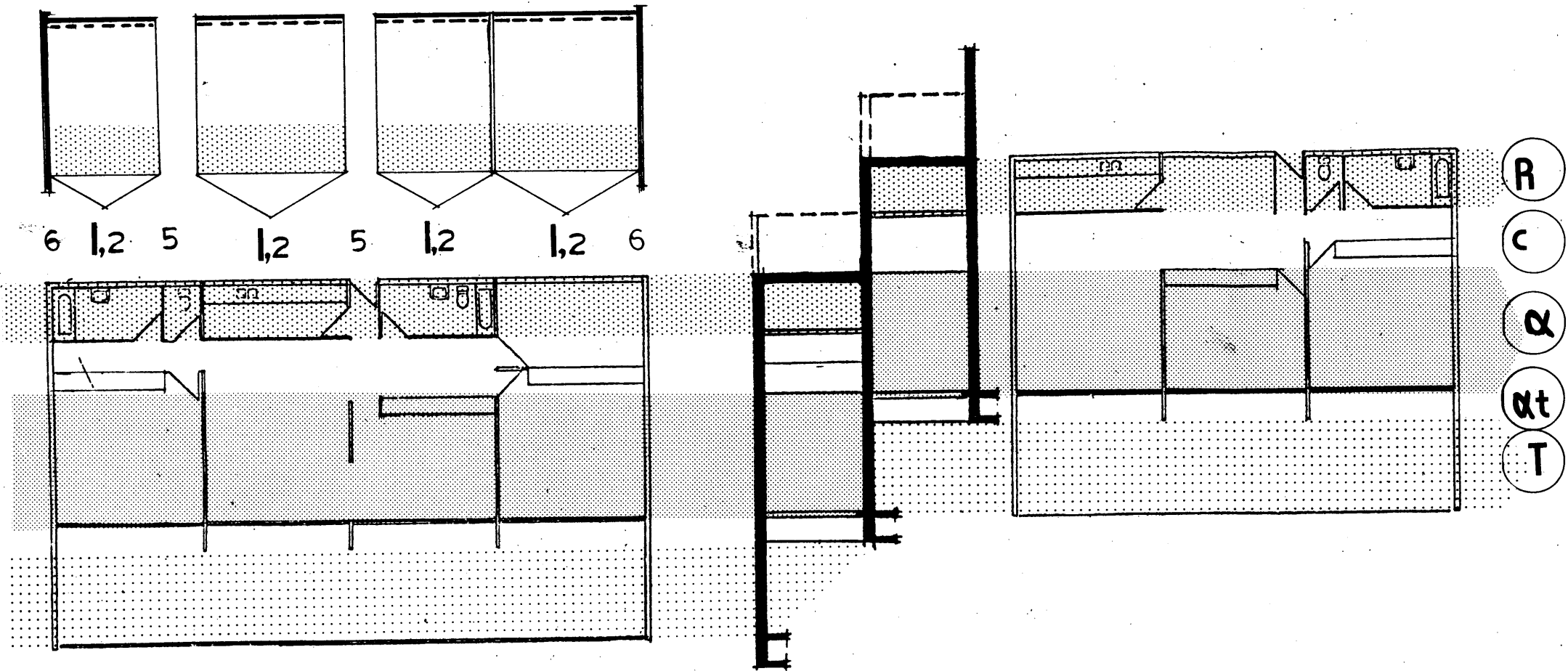

Project ; Orselina, Locarno, Corsier, Suisse

Architect ; Erwin Mühlestein

13

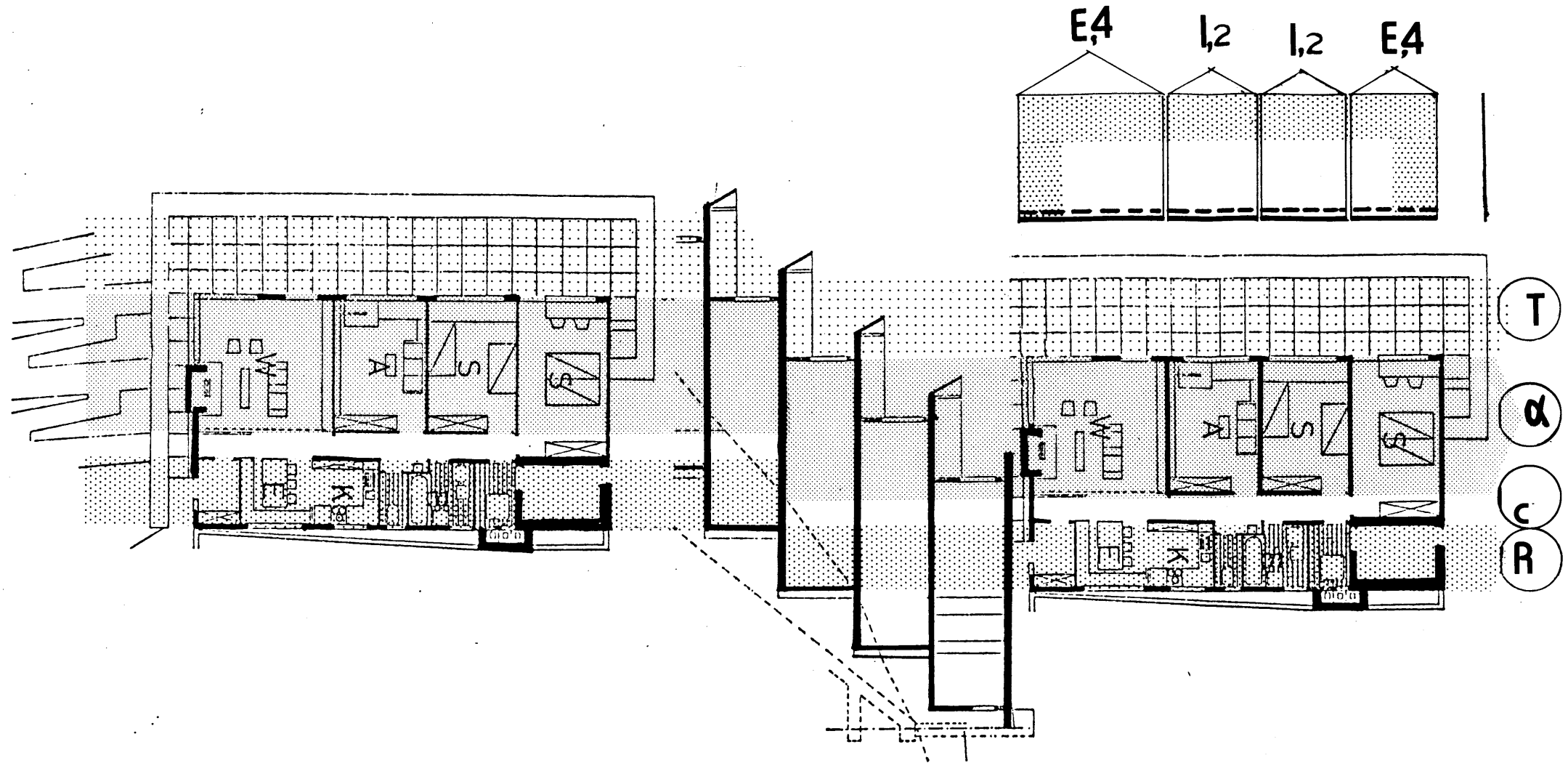



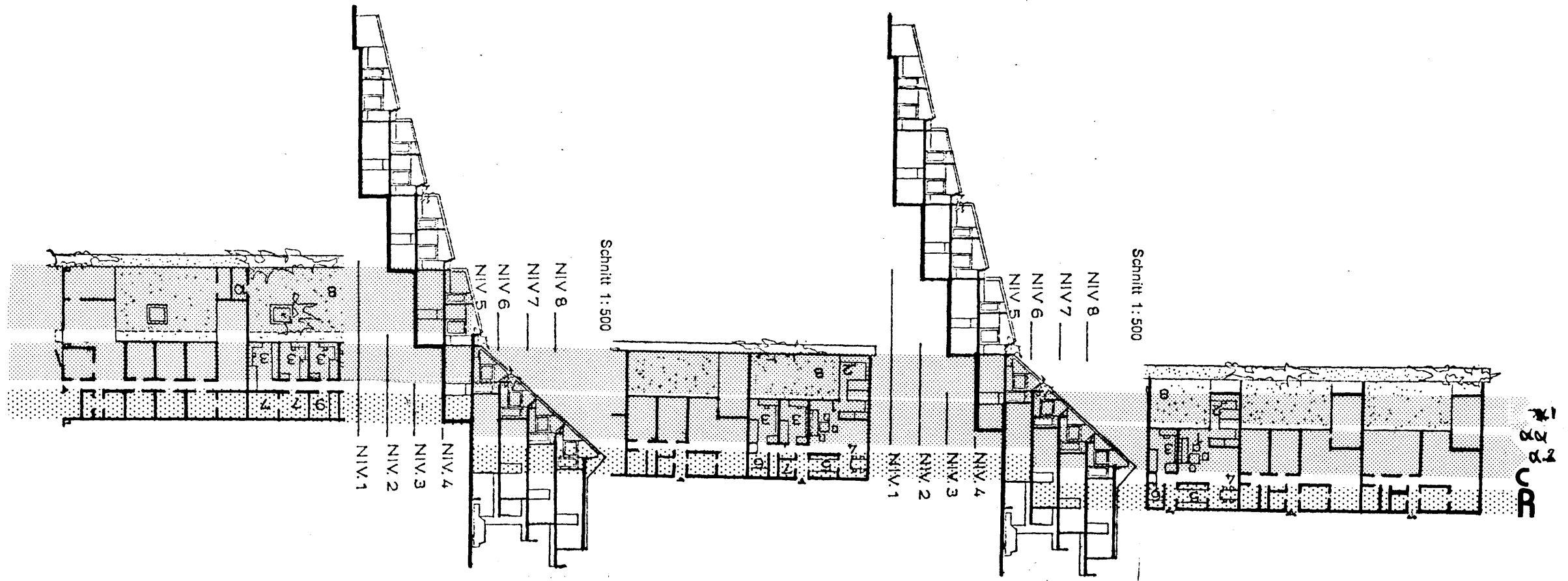

Project; Zug Swisse  
Architect; F. Stucky & R. Meull

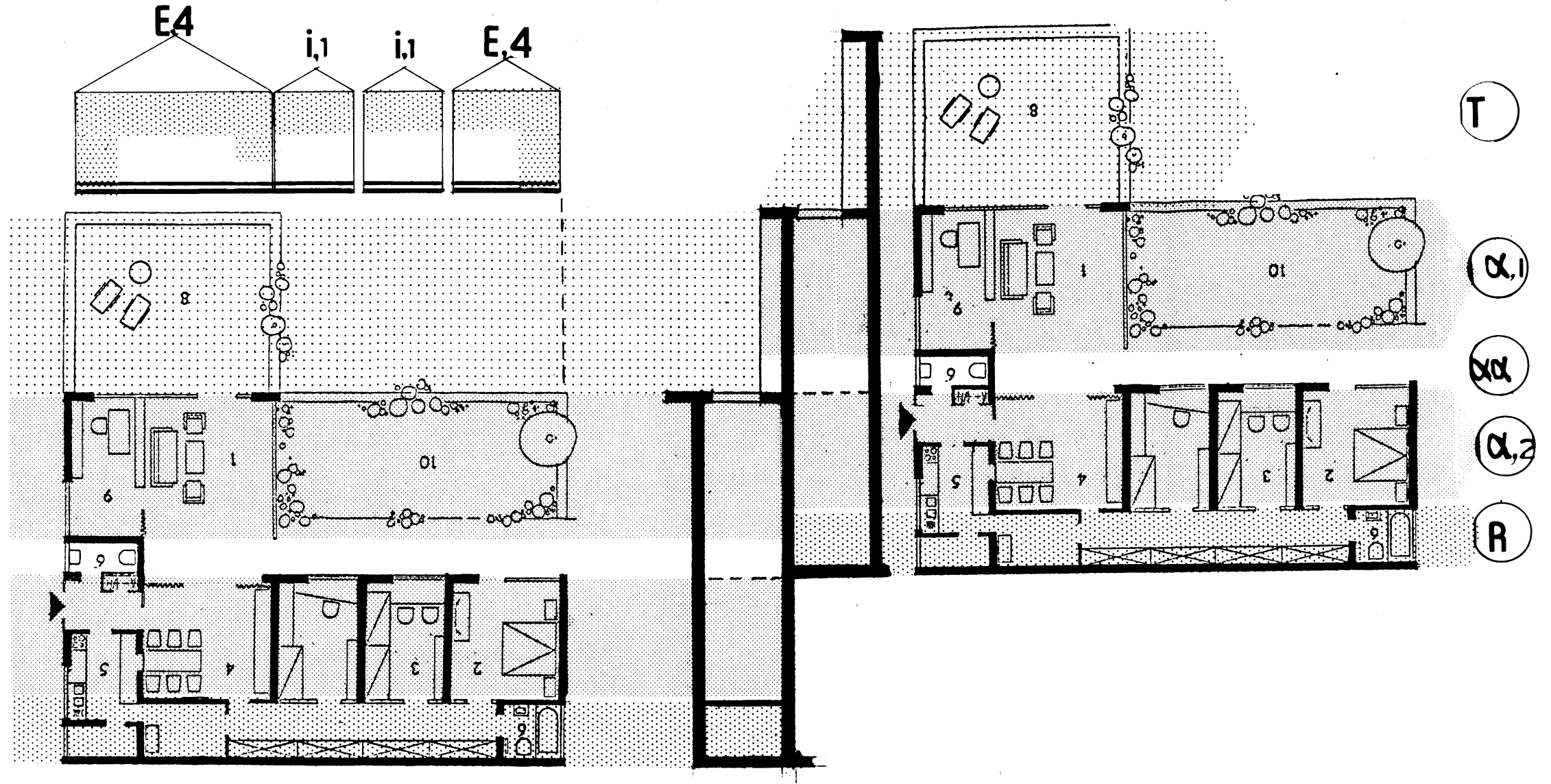

Project; Bad Godesberg, Germany  
Architect; Fallier + Schröder; R. Frey

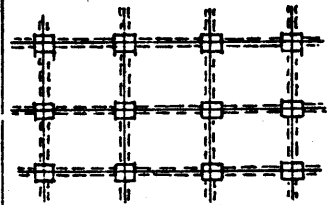
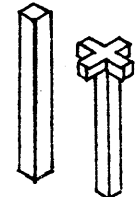

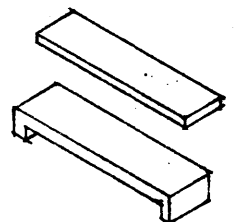
Project; Freiburg  
Architect; Günter Balsler

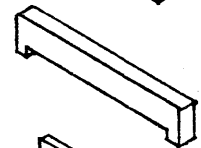
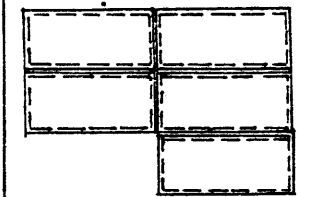
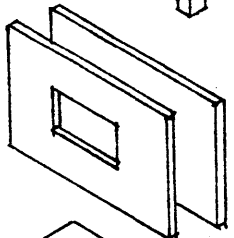
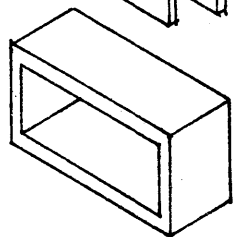
n STRUCTURAL SYSTEMS	ELEMENTS	EXAMPLES
<p>①</p>  <p>skeleton-frames</p>	<p>.1</p> 	<p>① (5); (15); (17);</p>
<p>②</p>  <p>load bearing walls</p>	<p>.2</p> 	<p>② (1); (2); (3); (4); (6); (8); (9); (10); (12); (14); (18); (21); (22); (23); (25);</p>
<p>③</p>  <p>panels</p>	<p>.3</p> 	<p>③ (2);</p>
<p>④</p>  <p>'boxes'</p>	<p>.4</p> 	<p>④ (16);</p>
<p>⑤</p> <p>combination of the other variants</p>	<p>.5</p> 	<p>⑤ (7 <u>(1+3)</u>); (13 <u>(1+3)</u>); (19 <u>(1+2)</u>); (20 <u>(1+2)</u>); (24 <u>(1+2)</u>);</p>
<p>⑥</p> <p>other solutions</p>		<p>Due to the unclarity of the available information on this parameter, most load bearing walls systems can be classified as skeleton systems.</p>

(4. ) THE APPLICATION OF THE MORPHOLOGICAL BOX IN IDENTIFYING  
AND CONTROL OF THE DESIGN PROCESS.

---

(4.1.1) THE STRUCTURING LIST OF THE PLANNING AND DESIGN STAGES.

---

The structuring list of the planning and design stages is set before proceeding to building the sequence of the planning and design decisions and the selection process. That list helps in clarifying and determining the specific planning and design procedure on a very general level. The elements which appear on that list are the various parameters groups (whole or partial), the various parameters without their variants. The parameters are organized hierarchically, following specific design objectives or external conditions. The importance of this stage is the chance which it provides to examine on a general level the planning procedure to be applied in each case, before getting 'deeper' into the detailed design process.



(4.1.2) THE SELECTION PROCESS

---

The selection process of a particular alternative from the 'legitimate' alternative possibilities of each parameter can be done only when the list of parameters and their respective variants is organized in a hierarchical order, reflecting a particular set of design objectives and contextual conditions.

The selection is done in two consecutive stages; In the first stage the 'legitimate' variants are identified for each parameter and marked (a circle in the variants indicator columns). In the second stage, one of the 'legitimate' alternatives is chosen (marked with a full dot). When the selection sequence continues into the next parameter the last decision joins the previous decisions on other parameters, setting a clearer, narrower reference framework for the decision on that parameter.

The 'end product' of this selection process is a distinctive list of one variant for each parameter (a 'morphology'). Each 'morphology' is essentially an alternative solution to the planning problem for which the specific 'morphological box' was designed.

(4.2.1) SEQUENCE No. (1) -

The 'classical'- modern planning and design process.

This planning and design process is considered by many schools and individual architects as a most rational process type. In this process, a contextual reality which is characterized by political, socio-economical and legal factors yields a specific planning and design program which reflects the reality and the aspirations of those who are involved in the programming process. The programmatic requirements together with the parameters which specify the site conditions, are acting as a basic planning input. The site conditions parameters group includes the slopes angle, the soil conditions, the orientation of the site to the sun, it's relation to the direction of the slope contoure lines and more. The analysis of that input is followed by establishing the basic abstract and physical concept of the building. That concept will refer, among other issues, to the choice of the building type and it's overall relation to the natural slope. A specific zoning system is established at that point as a design tool of the particular case. The selection of a specific zoning system is essential

in the case of terrace houses design as some of the critical design problems of that building type are related to the 'edges' of the buildings, and can be easily dealt with when th considered with the three dimensional zone system. Early decisions on the 'edges' elements of the building (those are the elements of the rear zone and the front terraces) are directly related to the basic building concept and can be handled independently with proper zoning system. The design process continues into the floor layouts phase which has two secondary alternatives; the decisions concerning the elements of the 'edges' precede the positioning of the internal functional spaces, or the second alternative is the adverse process. Following these decisions come the decisions concerning the 'hardware' elements of the building. These include the structural and the infrastructural building systems, (the infrastructural elements include the 'wet' cores, the ventilation systems (mechanical and natural), and the circulation systems.

The end product of that design process is expected to be a rational, optimized results -f the specific physical context as well as the political, socio-economic etc, context and the amount and kind of resources which were allocated in that case.

---

THE PLANNING AND DESIGN PROCESS





SEQUENCE No.(1) --- THE 'CLASSICAL' PLANNING AND DESIGN PROCESS

---

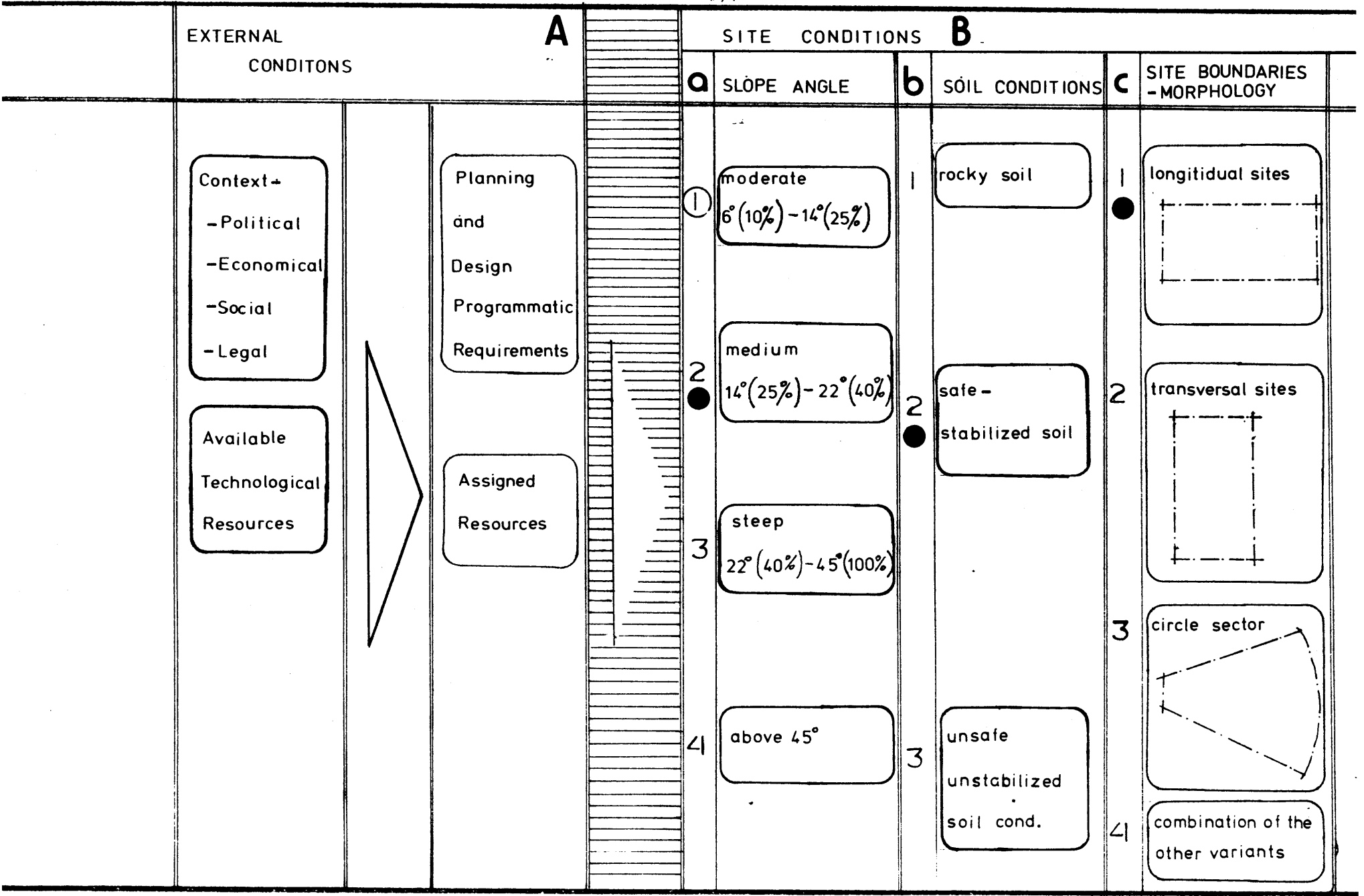
( A ) EXTERNAL CONDITIONS	Contextual conditions (political, socio-economic situation) programmatic requirements and available resources climatic conditions
( B ) SITE CONDITIONS	(a) the slope angle; (b) the soil conditions; (c) the site boundaries-morphology; (d) the slope contour lines direction (e) orientation of the site to the sun; (f) connection to the urban roads and public transportation networks
( C ) THE BUILDING TYPE	(g) generic building types; elements; (h) schematic concept of the <b>building</b> relation to the natural slope
( D ) THE HORIZONTAL ZONING SYSTEMS	(i) generic zoning systems- parallel to the slope; elements (zones and margins); (j) segmental zoning systems; elements (sectors and margins)
( E ) PRELIMINARY DESIGN DECISIONS-THE ALLOCATION OF 'PARTS' TO THE DIAGONAL ZONES	(k) the elements of the rear zone and the 'buffer' elements; (l) the elements of the front terraces zone
( F ) STRUCTURAL SYSTEMS	(m) the foundation system; elements; (n) the structural system above the ground; elements
( G ) INFRASTRUCTURE SYSTEMS	(o) wet cores( piping); elements; (p) the ventilation systems (natural and mechanical); elements; (q) pedestrian and vehicular circulation on the site.

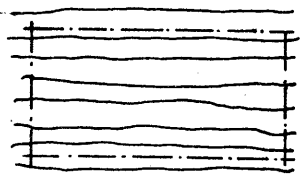
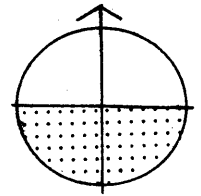
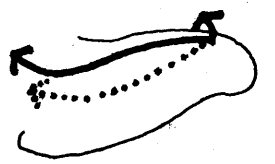
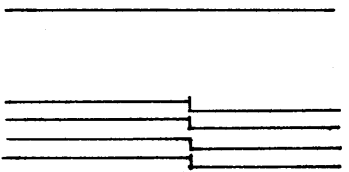
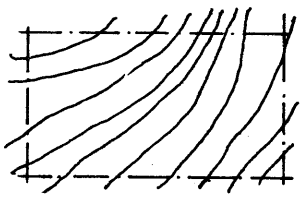
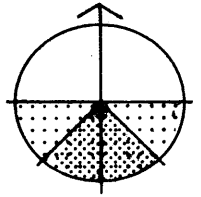
---

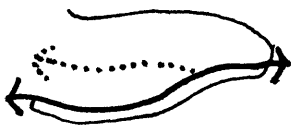
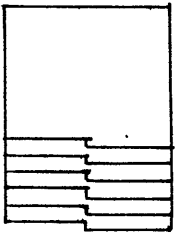
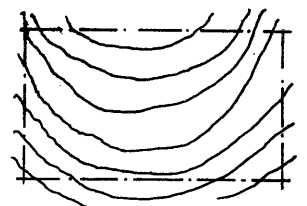
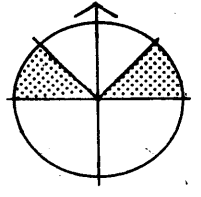
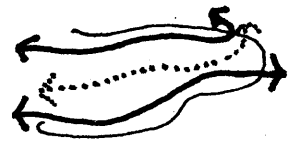
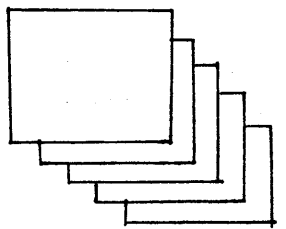
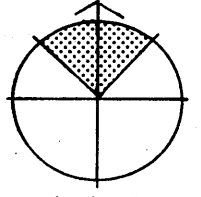
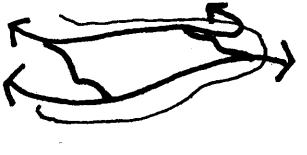

				<b>B</b>		THE BUILDING TYPE		
<b>d</b>	SLOPE CONTOUR LINES DIRECTION	<b>e</b>	ORIENTATION TO THE SUN	<b>f</b>	CONNECTION TO URBAN ROADS & TRANS NETWK	<b>g</b>	GENERIC TYPES	
1	 <p>parallel to the site boundaries</p>	1	 <p>acceptable</p>		1		1	
2	 <p>diagonal</p>	2	 <p>preferred</p>		2		2	
3	 <p>curved</p>	3	 <p>inferior</p>		3		3	
4	<p>combination of the other variants</p>	4	 <p>undesired</p>		4		4	<p>combination of the other variants</p>
					5			
					6	<p>combination of the other variants</p>		

C

SUB-TYPES

1 ●

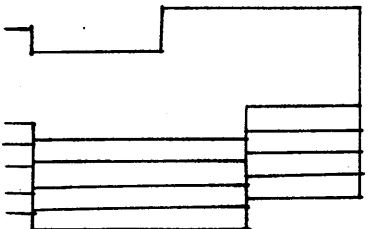

2

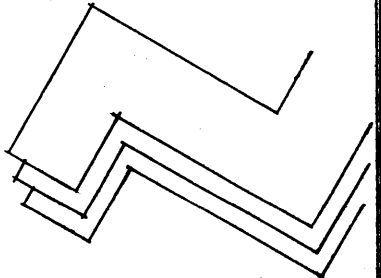

3

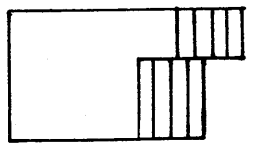

4

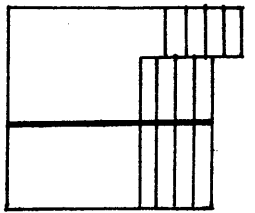

h

SCHEMATIC CONCEPT OF THE BUILDING RELATION TO THE NATURAL SLOPE

1 ○

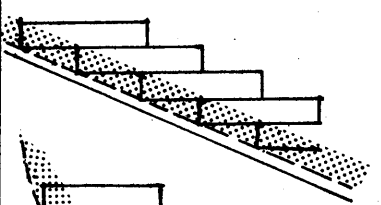

2 ●

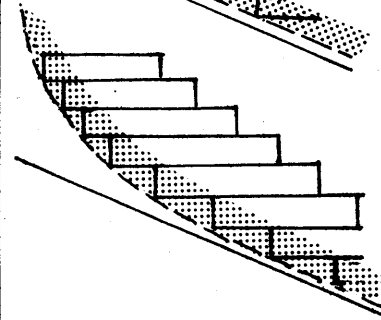

3 ○

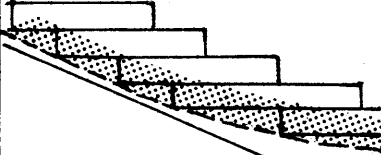

4 ○

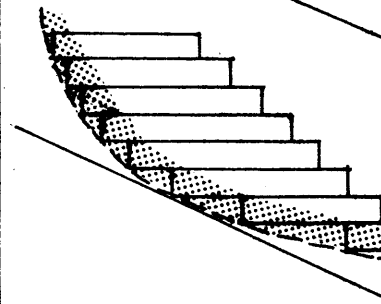

5 ○

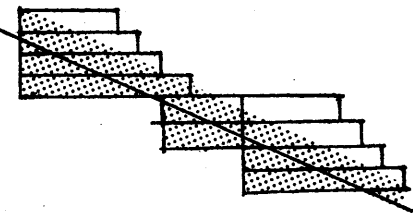

6

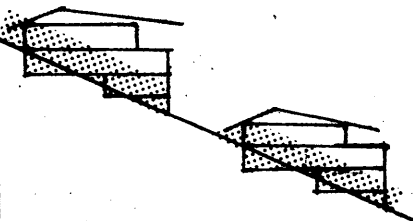

7

combination of the other variants

8

other solutions

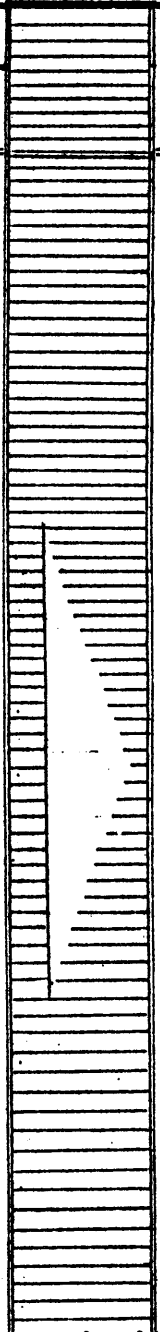

THE ZONING SYSTEMS - HORIZONTAL

D

**i** GENERIC-PARALLEL TO SLOPE-ZONING SYS.

ELEMENTS :

**j** SEGMENTAL ZONING

ELEMENTS :

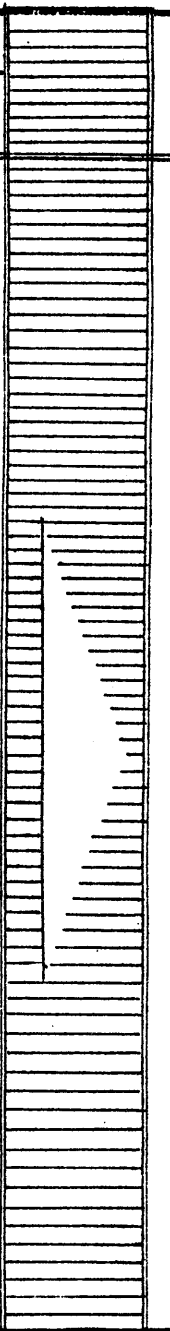
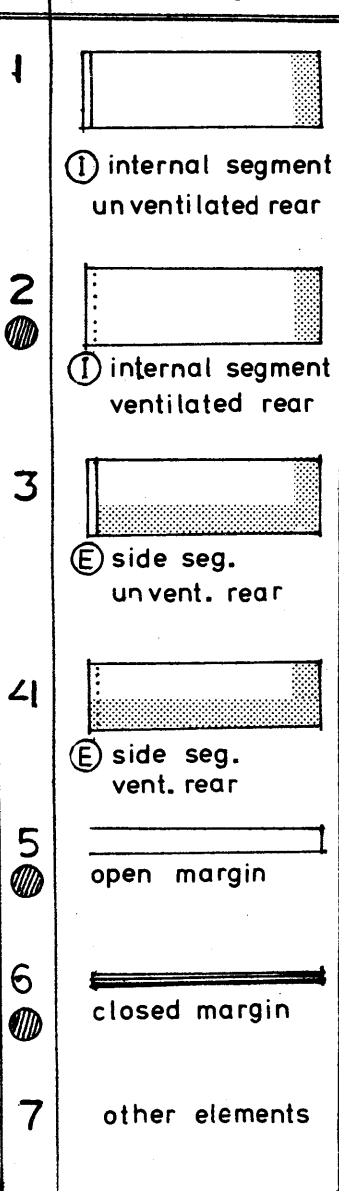
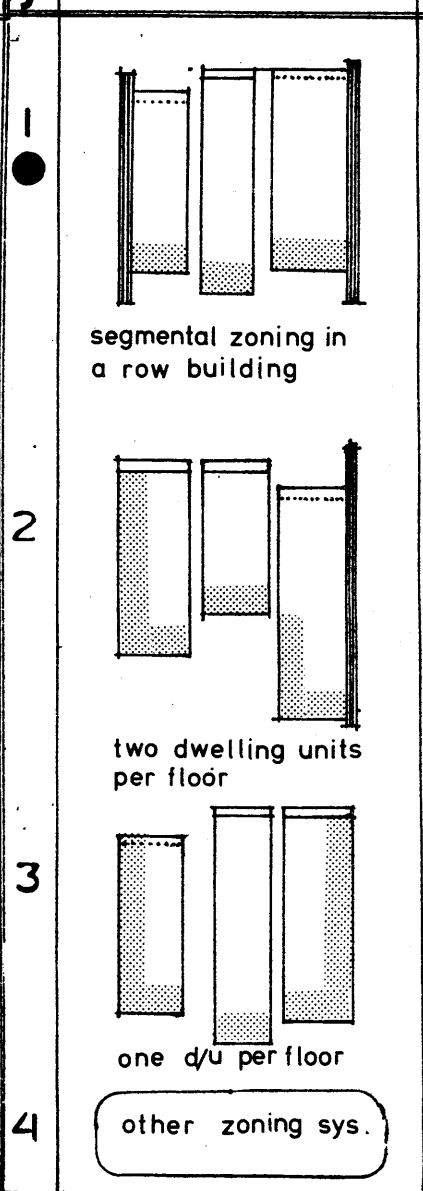
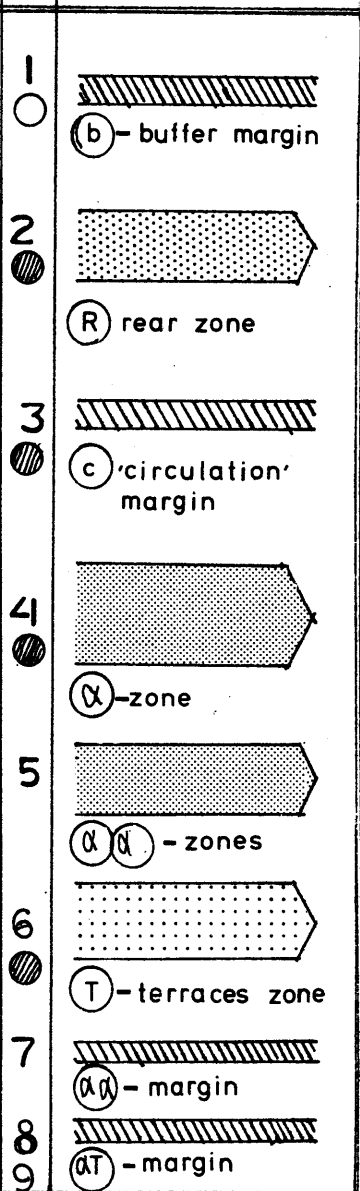
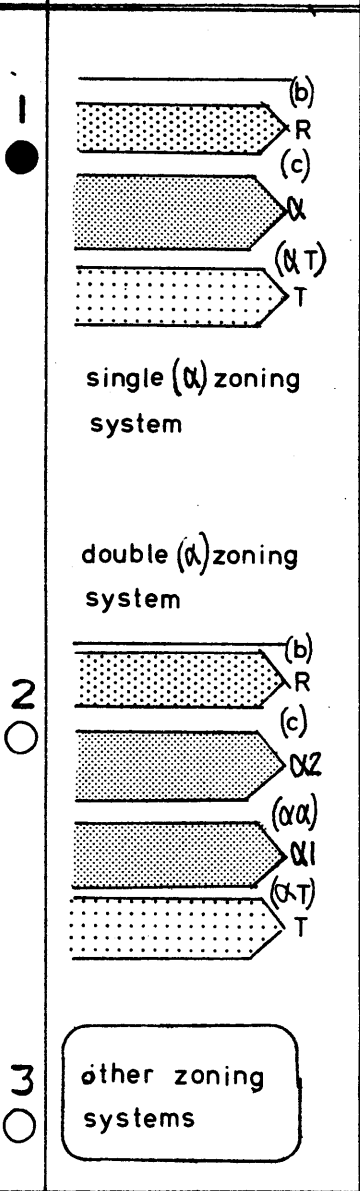



PRELIMINARY DESIGN DECISIONS - THE ALLOCATION OF GENERIC BUILDING PARTS TO

**k** THE REAR ZONE AND BUFFER ELEMENTS (ALT.)

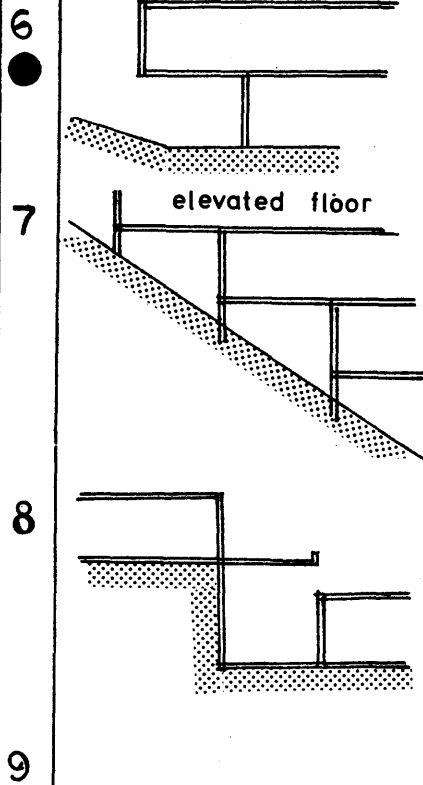
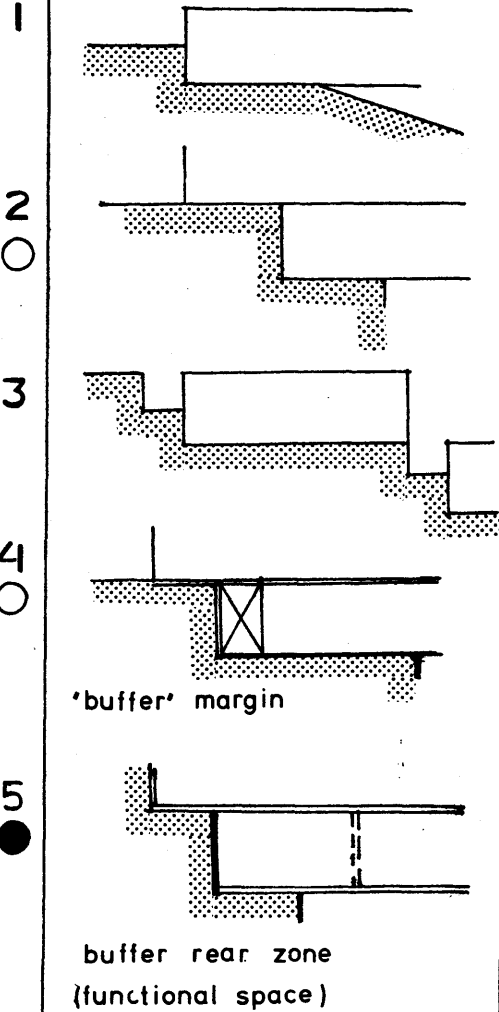

**L** THE FRONT-TERRACES ZONE

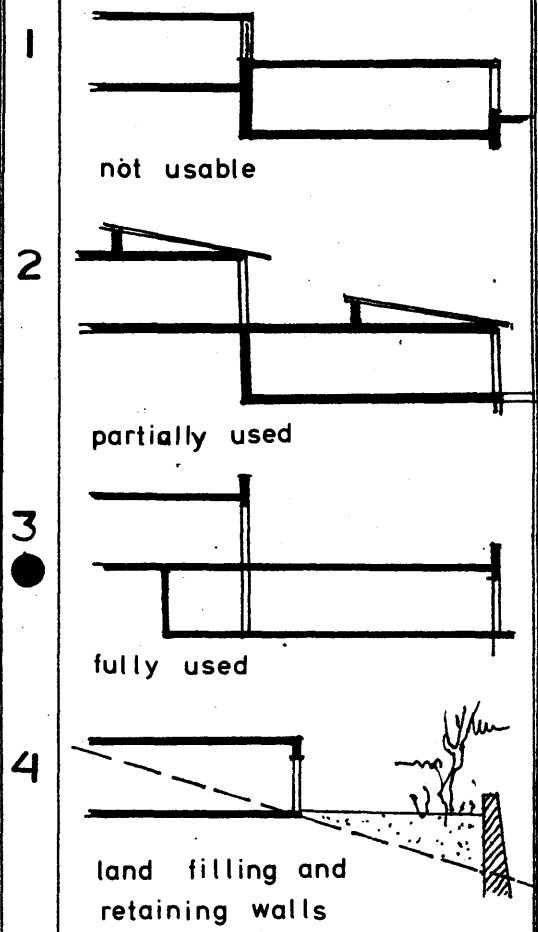

THE DIAGONAL ZONES

E

ELEMENTS

5

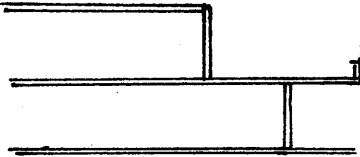

6

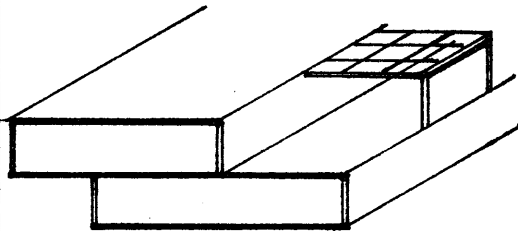

partially roofed terrace

7

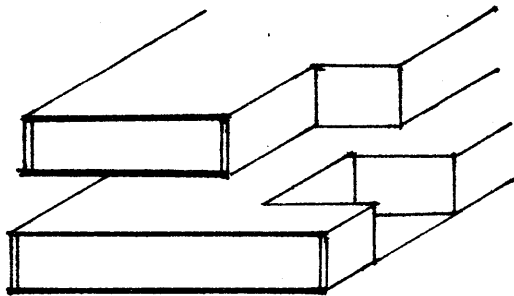

patio terraces

8



parking

9

function analysis



analysis of the building sectors



allocation and positioning of the residential functions in the interior spaces

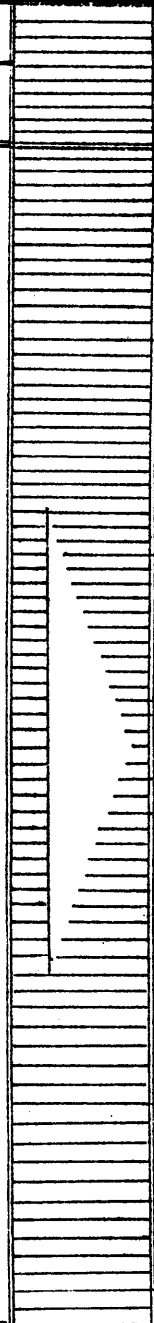

STRUCTURAL SYSTEMS

m FOUNDATION SYSTEMS

anchöring

1

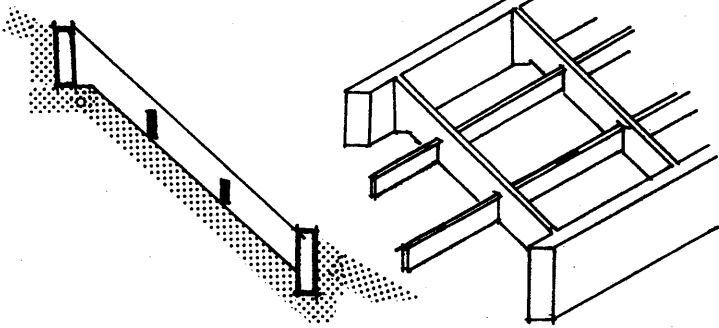

2

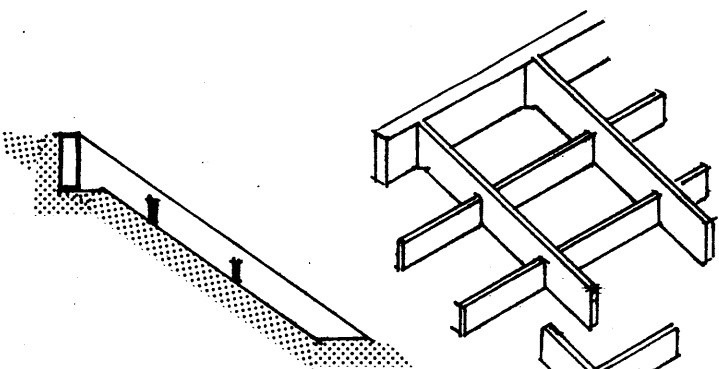

3

○

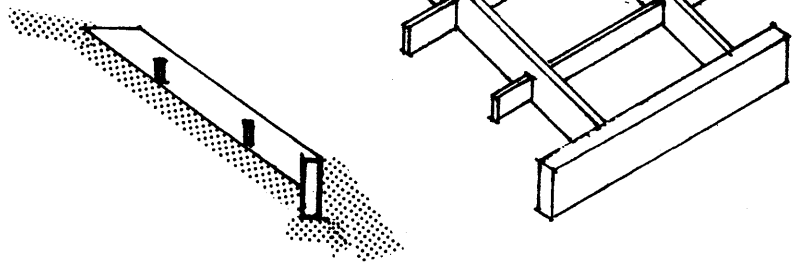

4

●

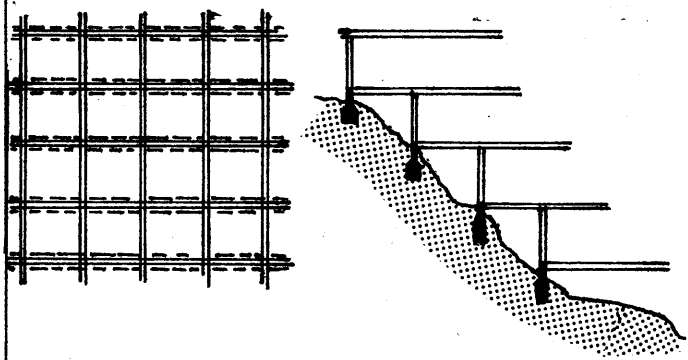

5

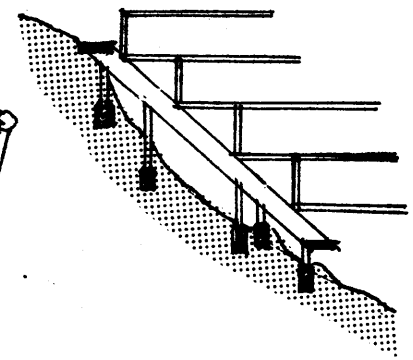
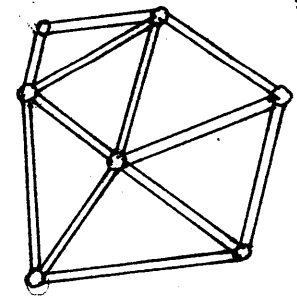

6

combination of the other variants



7

other solutions

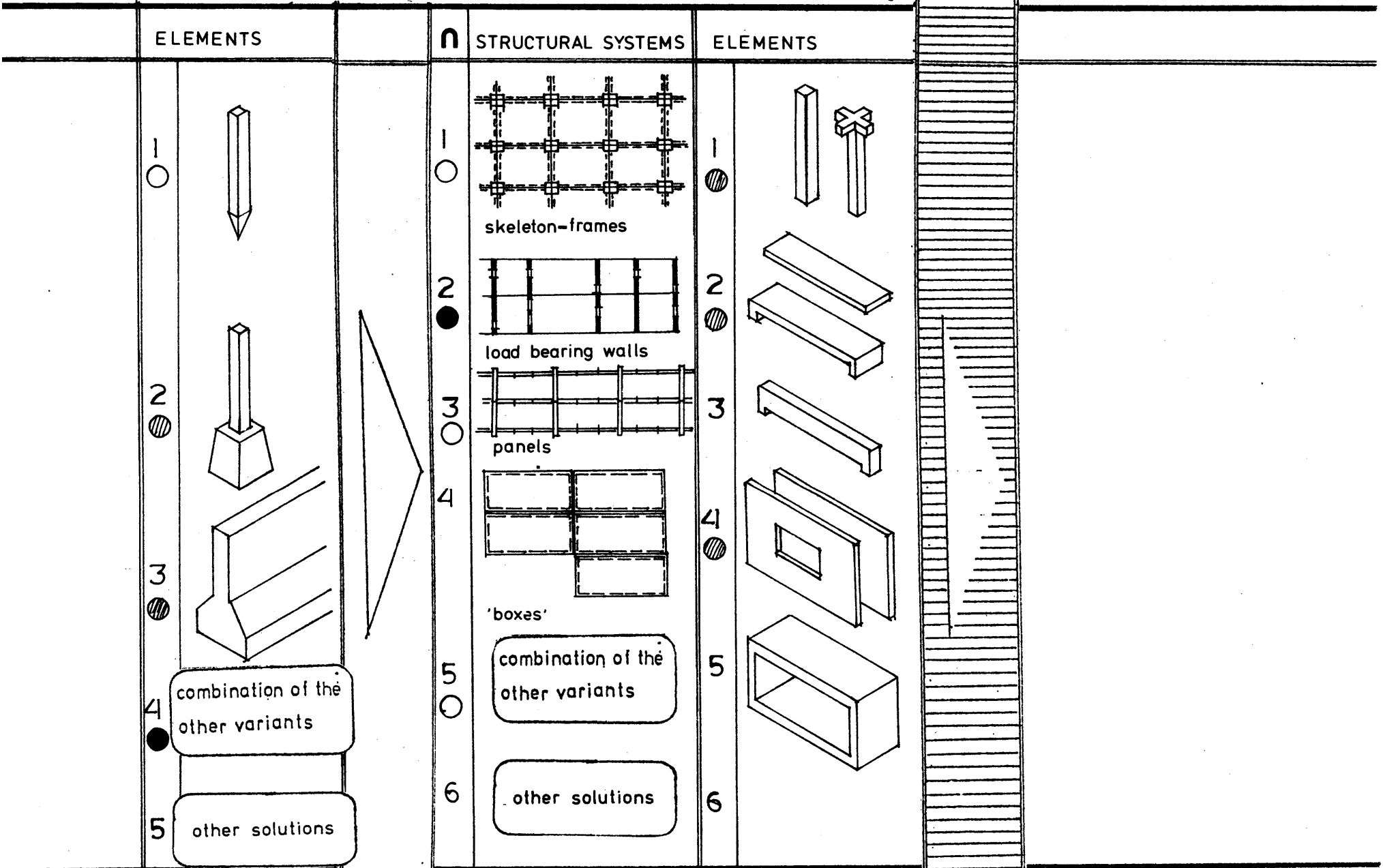
F

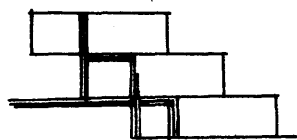
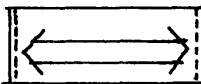
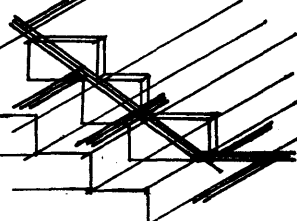
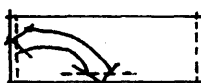
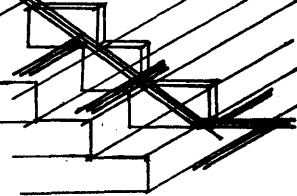
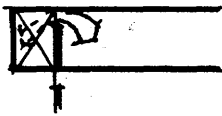

INFRA STRUCTURAL SYSTEMS

O	WET CORES	ELEMENTS	P	VENTILATION SYSTEMS	ELEMENTS	
1 ○	internal cores sys.	1 	1 ○	natural vent.	1 	
2 ○	external cores sys.	2  open cores	2 ○	mechanical vent.	2 	
3 ●	combination of the other variants	3  closed in ducts	3 ●	combination of the other variants	3 	
4 ○	other solutions	4 in the front zone (external)			4 	
		5 on the side elevation (ext.)			5 individual a/c units for rooms or dwel. unit	
		6 in the rear zone			6 central a/c sys.	
		7 combination of the other variants			7 other	
		8 other solutions				

**9** CIRCULATION SYSTEMS

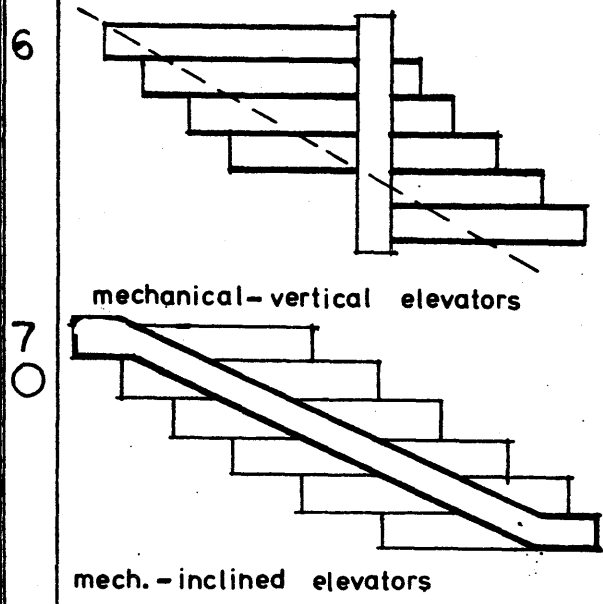
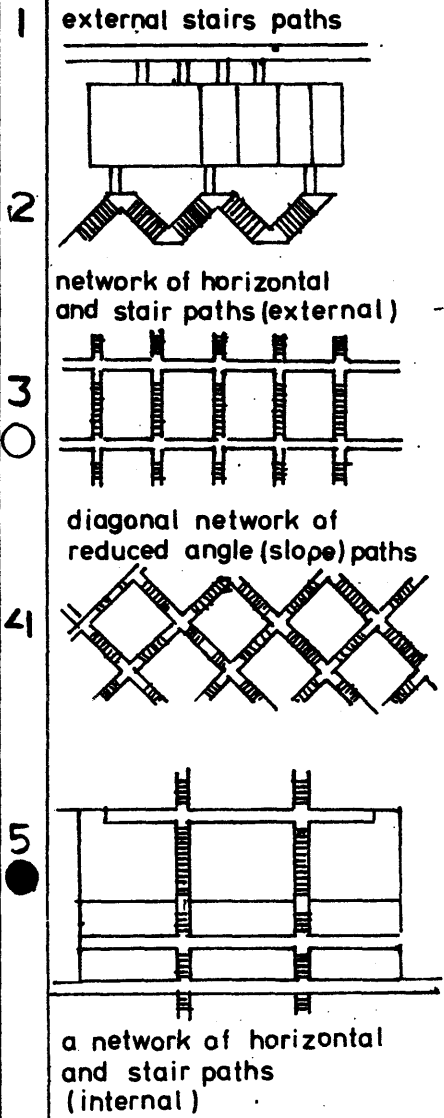

**8**

combination of the other variants

other solutions

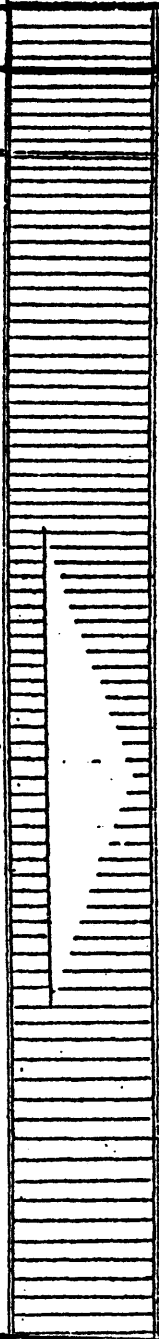

specific detailed design

EXECUTION

**G**

**H**

(4.2.2) SEQUENCE No.(2) -

planning and design with exceptional site conditions

This example demonstrates the way by which the first sequence may adjust itself to a new situation where some of the site condition parameters are assigned extreme values which result in difficult planning problems. This new situation calls for changing the regular hierarchy of the planning decisions , as it was expressed in the first sequence example .

The two site condition parameters which got extreme values are ; the angle of the slope (a), (a steep slope (a.3)), and the orientation of the sloped site to the sun (inferior orientation (e.3)). The steep slope situation may effect primarily the design of the building foundation system, and thus that decision has to be done earlier in the design process to provide it's increased independence of other design decisions. That independence is justified the rationality of the foundations design (it's direct response to external conditions and possibly it's effect on the following design decisions). The problem of the inferior orientation of the sloped site to the sun can be faced with two decisions; the first is the decision on the building type, and the second is on the zoning

systems which will be applied in it's design. Some of the problems of the inferior orientation to the sun can be solved by choosing a building type which has more than one exterior walls. The types which may be favourable in that situation are the buildings with one or two dwelling units per floor, or linear-row buildings with fragmented facade lines (broken or curved lines).

The two decisions which have already been made may determine to a large extent the concept of the overall relation of the building to the natural slope. The zoning systems which are determined at this early stage allow the manipulation of the internal elements of the building into a position which overcomes the overall inferior orientation of the building to the sun. These relations between various design decisions allow the implicit introduction of preliminary considerations of the internal arrangement of the building, into an earlier design stage.

The previous decisions narrow the range of possibilities of alternative structural systems of the building. To avoid conflicts between the remaining possibilities for the struc-



tural system and the following design decisions, the decision on the structural system is made before proceeding into the next planning stages of allocation of building elements (or 'parts') to the rear and the front terraces zones and completing the main design stages with the infrastructural elements and the complete design of the dwelling units.

SEQUENCE No.(3) -

Planning and design process, originated by existing building construction system.

---

This planning and design sequence is basically different from the other two sequences mainly in the first stages of the process. It describes a planning and design process which was originated after a building construction system was made available and could be applied with minor modifications on various site conditions. Such systems can be put into use either by public authorities ( for various reasons as the economical advantages of the industrialized building, easier centralized management possibilities, increasing the housing stock at a



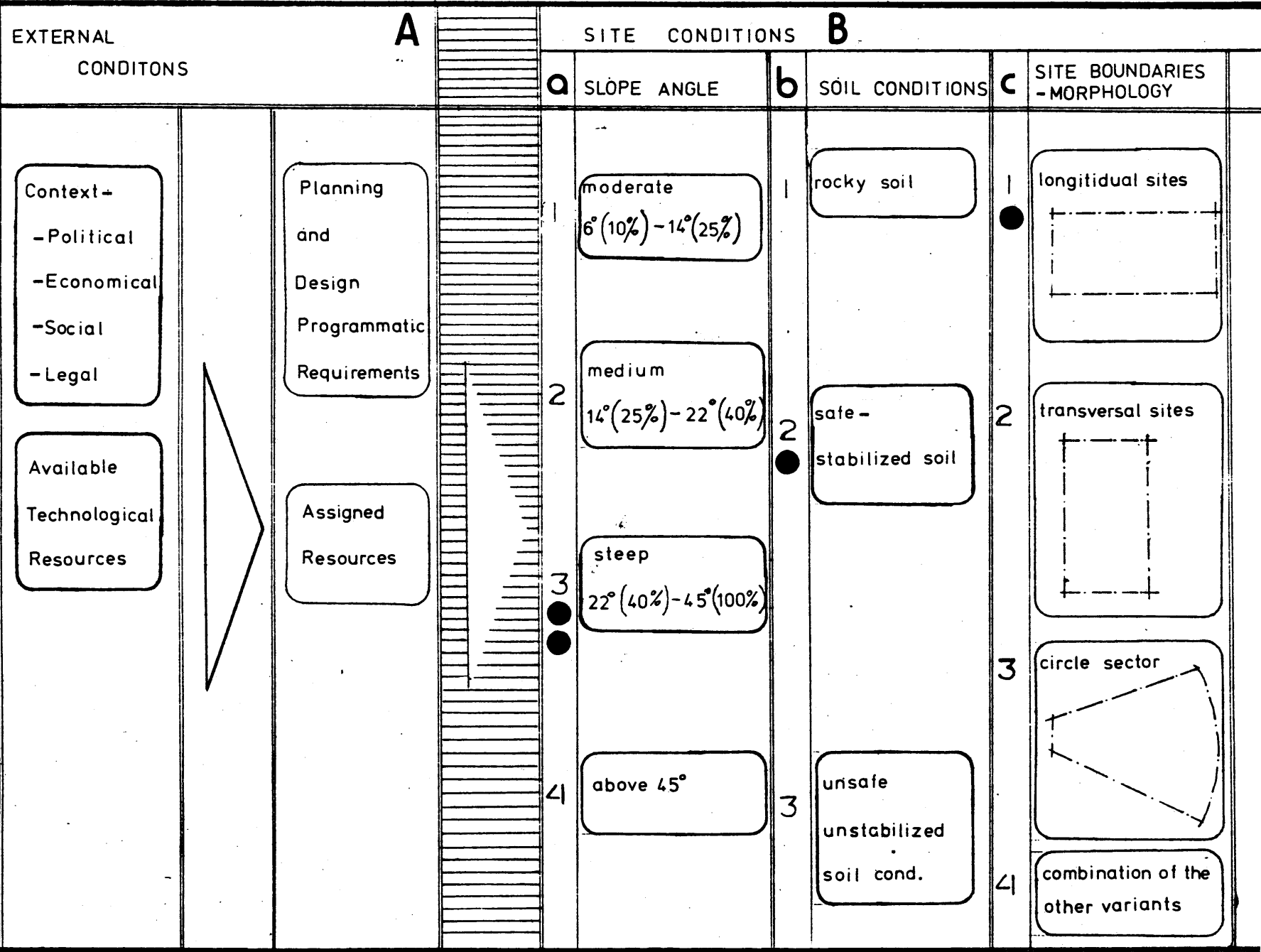

B

d	SLOPE CONTOUR LINES DIRECTION	e	ORIENTATION TO THE SUN	f	CONNECTION TO URBAN ROADS & TRANS NETWORK
---	-------------------------------	---	------------------------	---	---

1 ●

2

3

4

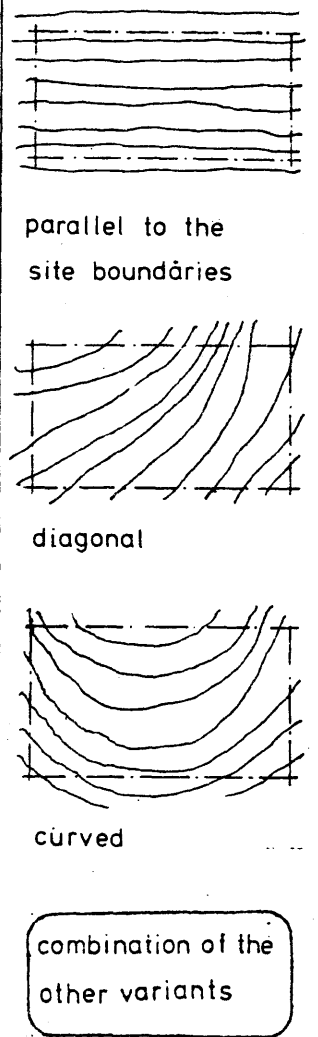

1

2

3 ●

4

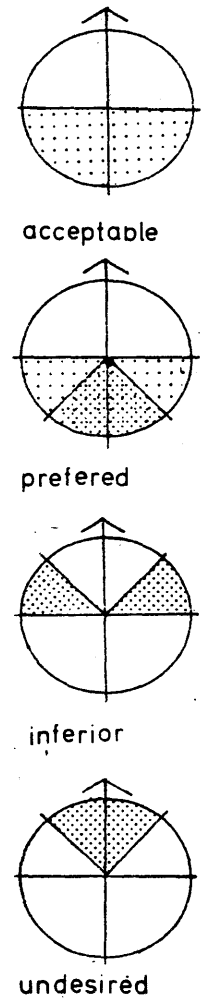

1 ●

2

3

4

5

6

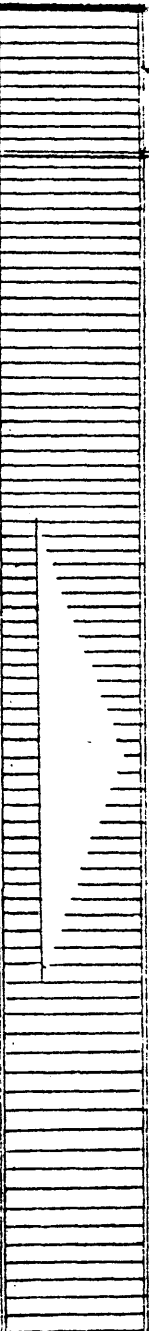
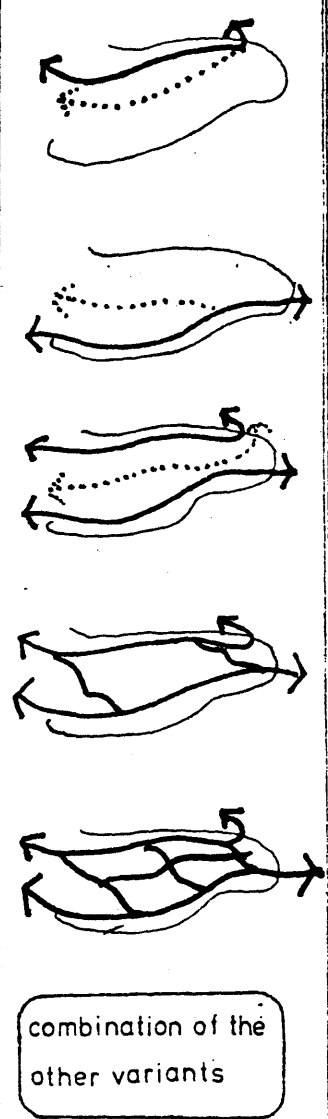

STRUCTURAL SYSTEMS

m FOUNDATION SYSTEMS

anchöring

1  
○

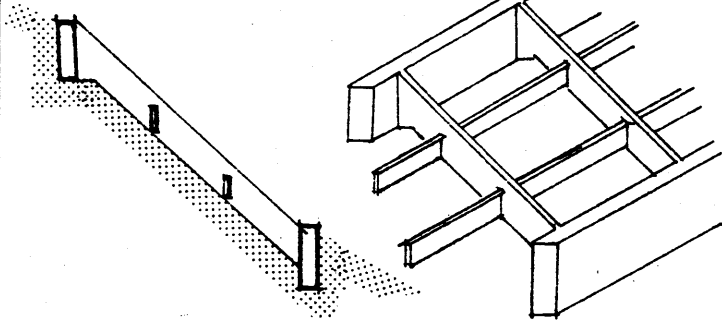

2  
●

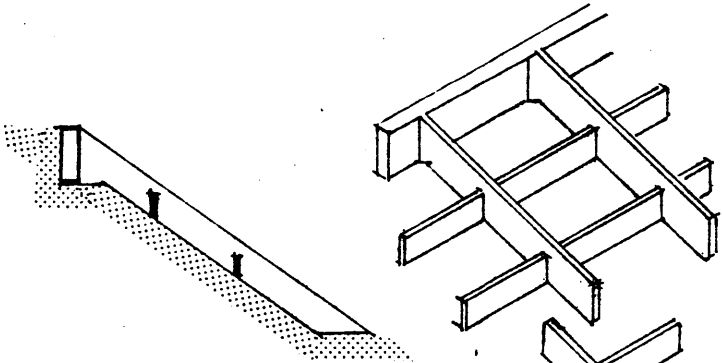

3  
○

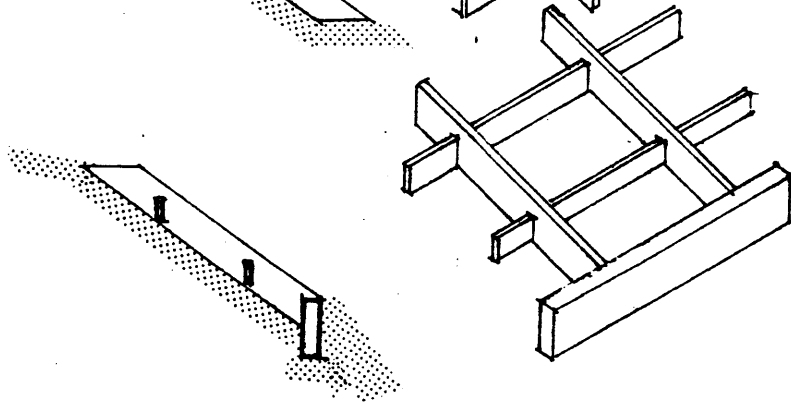

4  
○

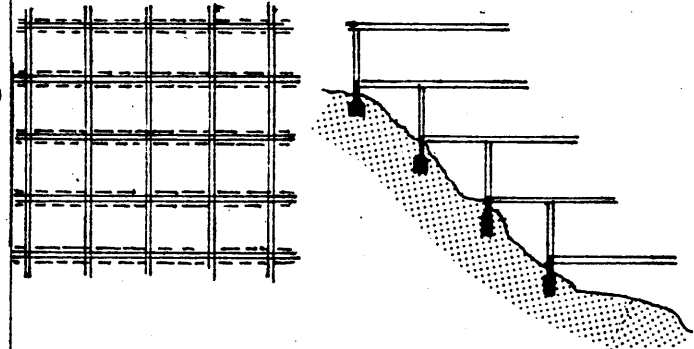

5  
○

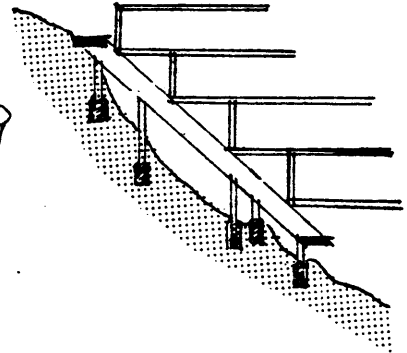
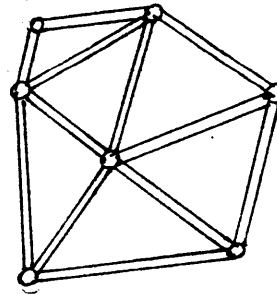

6  
○

combination of the other variants

7  
○

other solutions

**F**



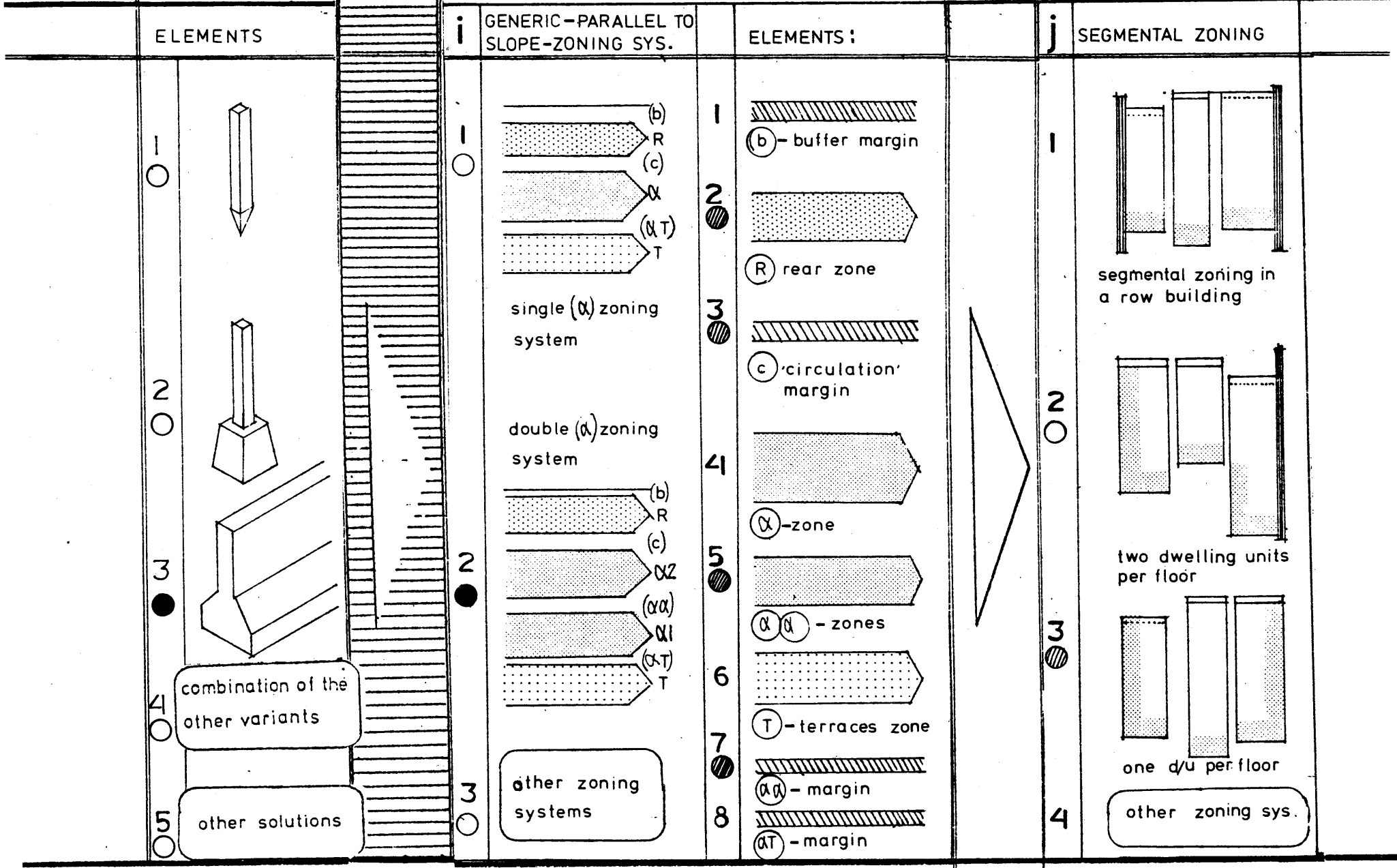

THE ZONING SYSTEMS - HORIZONTAL

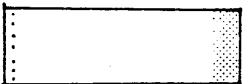

**D**

THE BUILDING TYPE

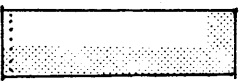
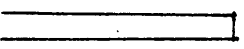
ELEMENTS :

- 1   
① internal segment  
un ventilated rear
- 2   
① internal segment  
ventilated rear
- 3   
⑤ side seg.  
un vent. rear
- 4   
⑤ side seg.  
vent. rear
- 5   
open margin
- 6   
closed margin
- 7 other elements

**9** GENERIC TYPES

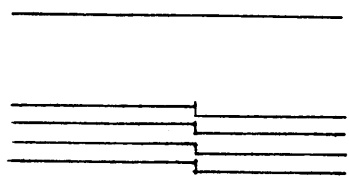
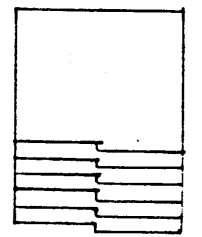
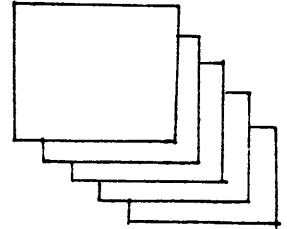
- 1 
- 2 
- 3 
- 4 combination of the other variants

SUB-TYPES

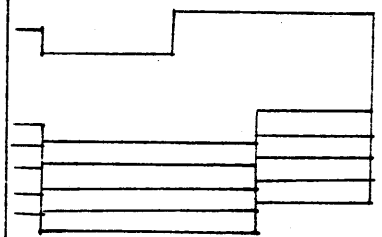
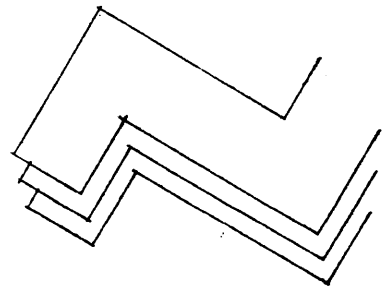
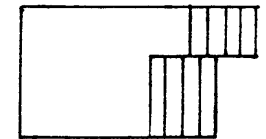
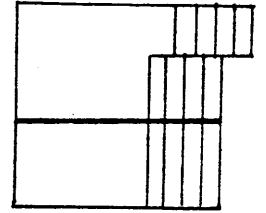
- 1 
- 2 
- 3 
- 4 

C

F

**h** SCHEMATIC CONCEPT OF THE BUILDING RELATION TO THE NATURAL SLOPE

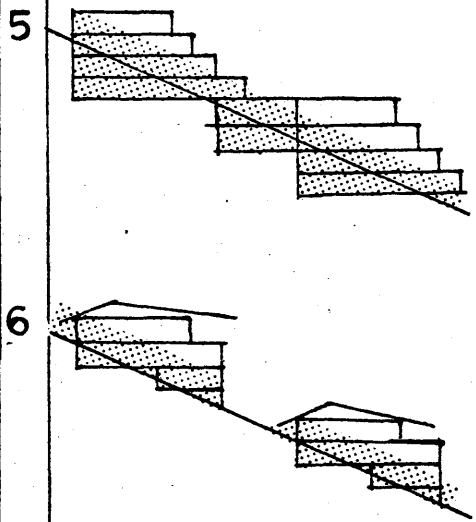
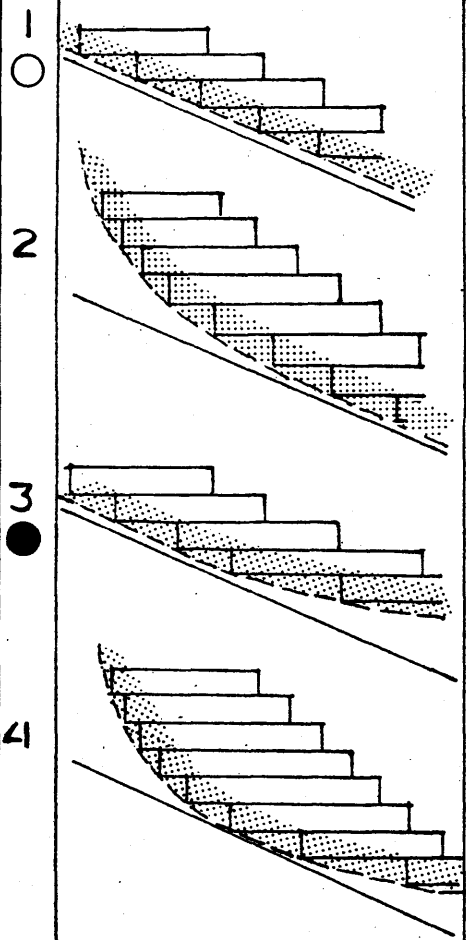

combination of the other variants

other solutions

8

STRUCTURAL SYSTEMS

**n** STRUCTURAL SYSTEMS      ELEMENTS

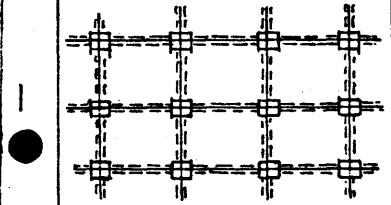

skeleton-frames

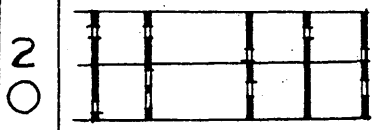

load bearing walls

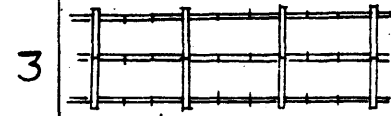

panels

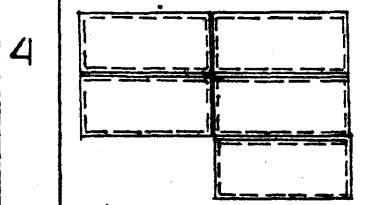

'boxes'

5 combination of the other variants

6 other solutions

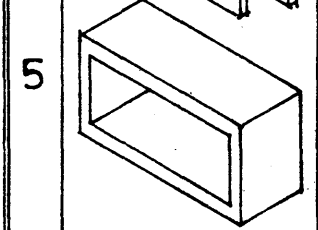
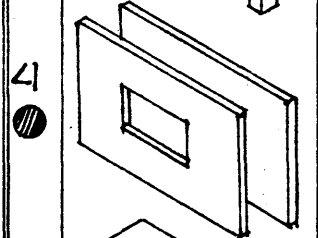
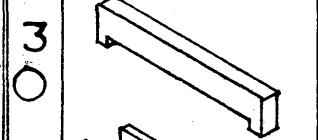
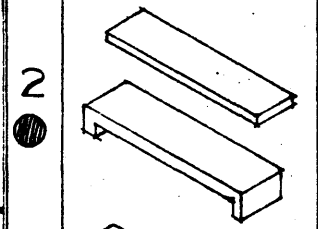
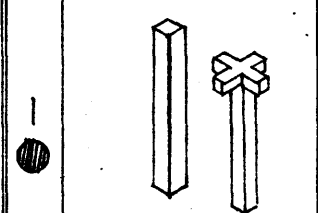



PRELIMINARY DESIGN DECISIONS - THE ALLOCATION OF GENERIC BUILDING PARTS TO

**k** THE REAR ZONE AND BUFFER ELEMENTS (ALT.)

**L** THE FRONT-TERRACES ZONE

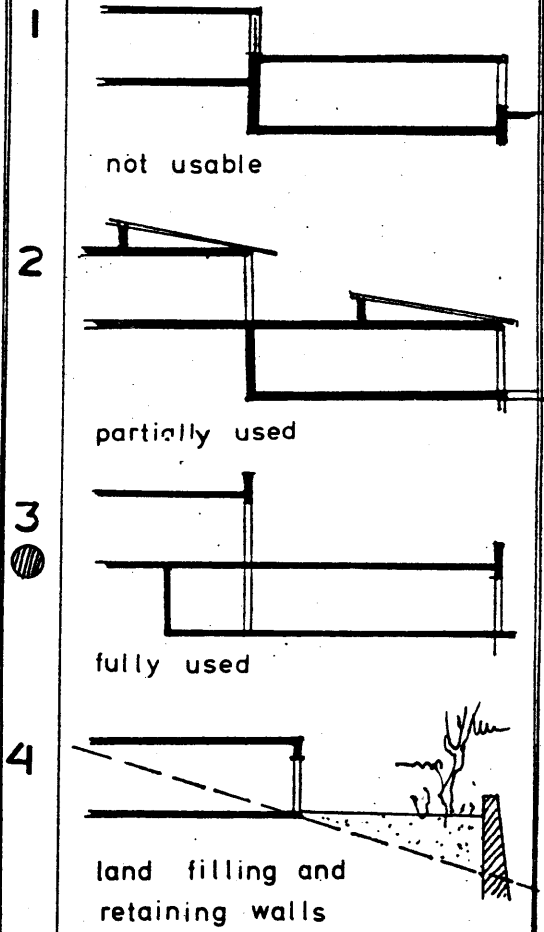
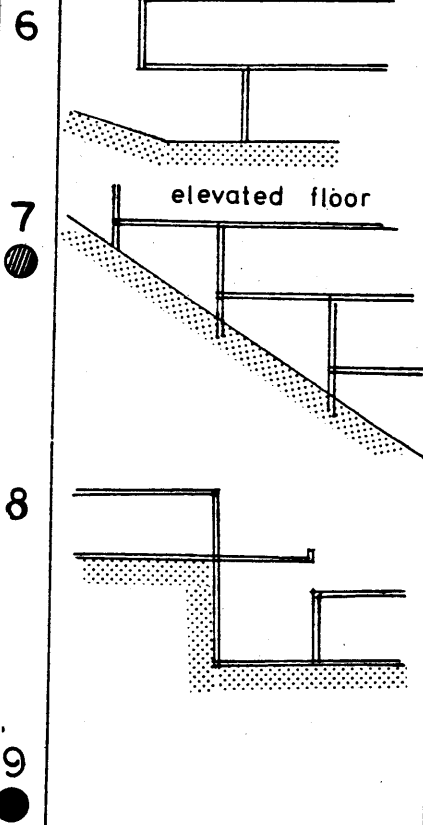
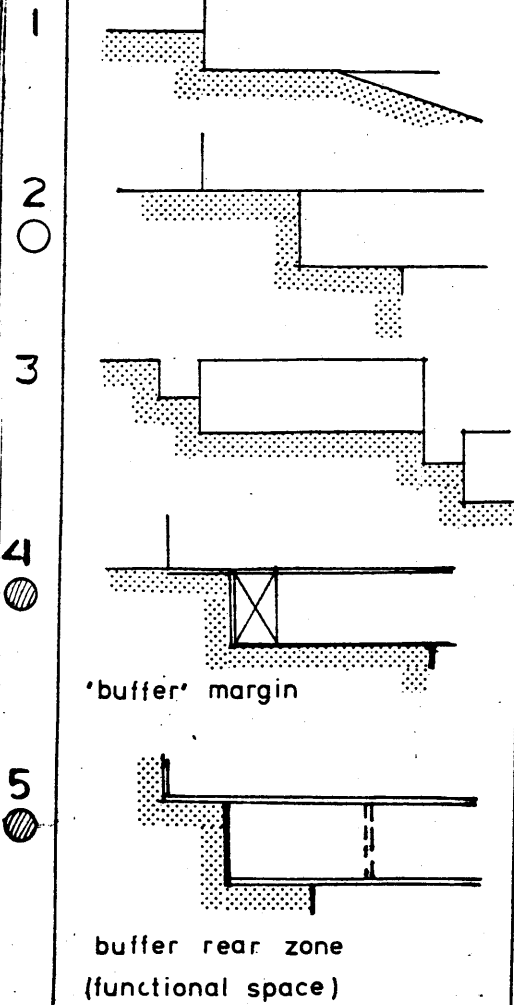

THE DIAGONAL ZONES

E

ELEMENTS

5  
○

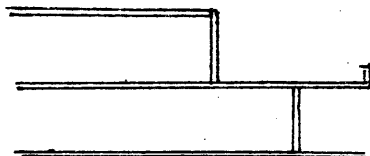

6

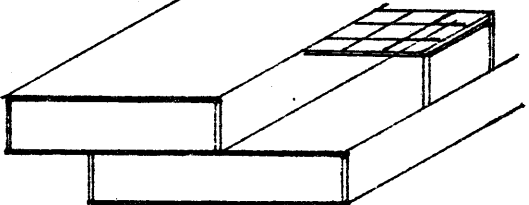

partially roofed terrace

7  
●

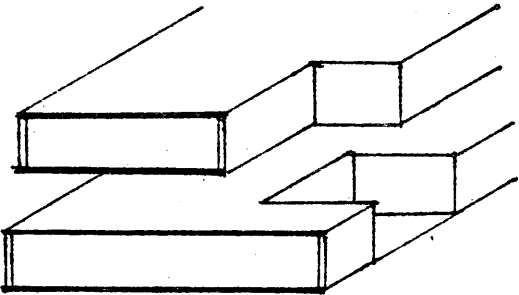

patio terraces

8

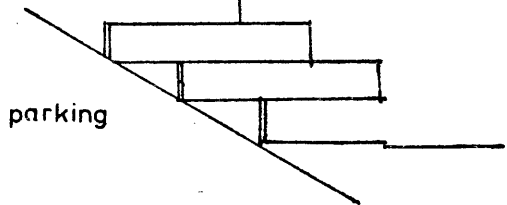

parking

9

function analysis



analysis of the building sectors



allocation and positioning of the residential functions in the interior spaces

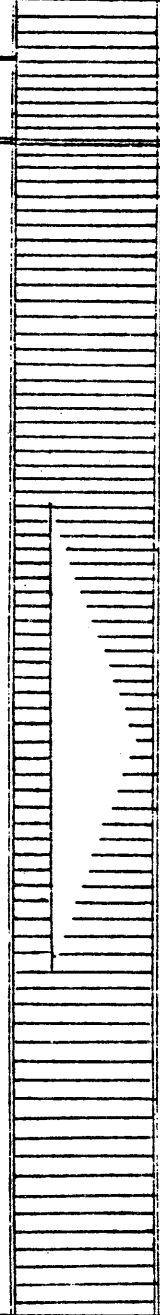

INFRA STRUCTURAL SYSTEMS

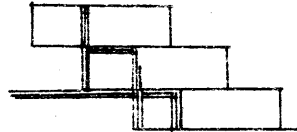
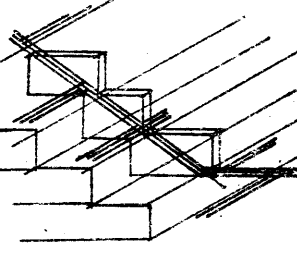
O	WET CORES	ELEMENTS	P	VENTILATION SYSTEMS	ELEMENTS
1 ○	internal cores sys.	1 	1 ●	1 ●	1 ●
2 ○	external cores sys.	open cores 2 ○	2 ○	2 ○	2 ○
3 ●	combination of the other variants		3 ○	3 ○	3 ○
4 ○	other solutions	closed in ducts		3 ●	3 ●
		3 in the front zone (external)		4 ○	4 ○
		4 on the side elevation (ext.) 4 ●		4 ○	4 ○
		5 in the rear zone 5 ●		5 ○	5 ○
		6 combination of the other variants 6 ●		6 ○	6 ○
		7 other solutions 7 ○		7 ○	7 ○
			1 ●	1 ●	1 ●
			2 ○	2 ○	2 ○
			3 ○	3 ○	3 ○
				3 ●	3 ●
				4 ○	4 ○
				4 ○	4 ○
				5 ○	5 ○
				6 ○	6 ○
				7 ○	7 ○

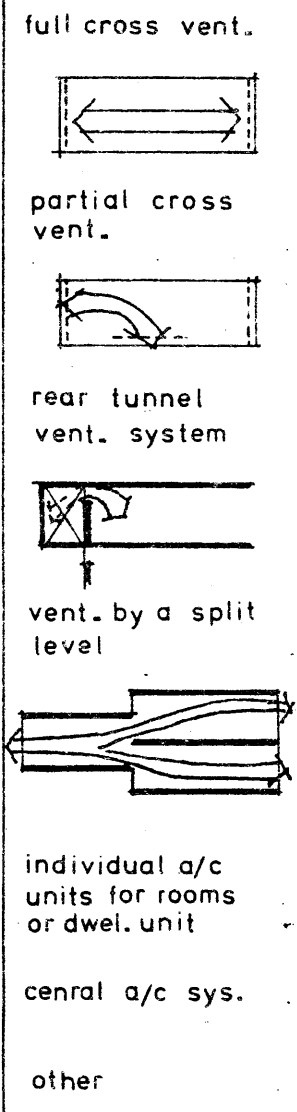

G

H

9 CIRCULATION SYSTEMS

1 external stairs paths

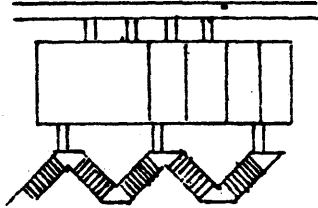

2 network of horizontal and stair paths (external)

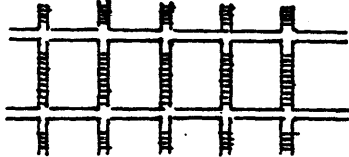

3 diagonal network of reduced angle (slope) paths

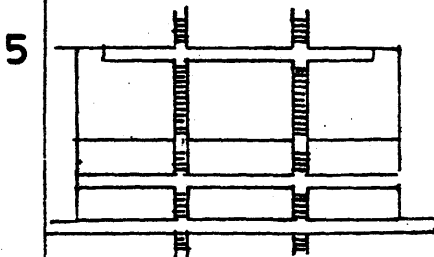
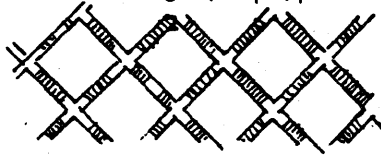

a network of horizontal and stair paths (internal)

6

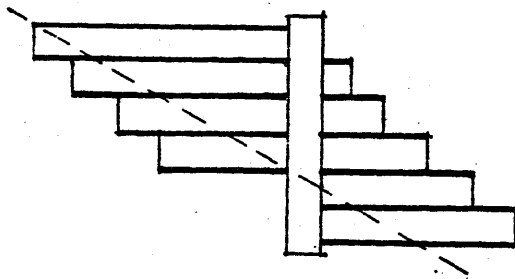

mechanical-vertical elevators

7

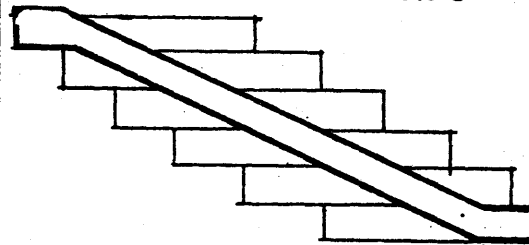

mech.-inclined elevators

8

combination of the other variants

9

other solutions

specific detailed design



EXECUTION



short time, etc.), or by the manufacturers who are naturally interested in initiating projects which implement their systems.

The contextual factors as the socio-economical situation political and legal characteristics and existing sets of norms and standards or various housing design and planning programs serve as the background from which that building industry emerged.

Once a project is initiated, the planning and design process starts as in the other two sequences, by identifying the specific site conditions. The next planning stages include choosing the building type, defining it's overall relation to the sloped site, as a result of the combination of the specific construction system which will be applied and the specific site conditions. These decisions are followed by decisions on the building foundation and infrastructural systems. If the zoning systems are not determined by the building construction system they should be chosen before the decisions on the infrastructural systems as they can link between the construction system and the structural system which it implies and the functional design of the building. By that point all the decisions which were made define the building support system.

The building systems which are still to be selected are acting as infill systems. The rear and the front terraces zone elements are designed and allocated as part of the adaptation process of the building construction method which was designed for a general case, to the sprcific site conditions.

---

THE PLANNING AND DESIGN PROCESS

SEQUENCE No.(3) --- PLANNING PROCESS, INITIATED WITH AN EXISTING BUILDING CONST. SYSTEM

---

( A ) EXTERNAL CONDITIONS	contextual conditions (as socio-economical, political situation programmatic requirements and available resources climatic conditions
------------------------------	---

---

( F ) STRUCTURAL SYSTEMS (II)	(n) the structural systems above the ground level; elements
----------------------------------	---

---

( B ) SITE CONDITIONS	(a) the slope angle; (b) the soil conditions; (c) the site boundaries-morphology; (d) the direction of the slope contour lines; (e) orientation of the sun to the site; (f) connection to the urban roads and public transportation networks;
--------------------------	--

---

( C ) THE BUILDING TYPE	(g) the generic building types; sub-types; (h) schematic relation of the building to the natural slope
----------------------------	---

---

( F ) STRUCTURAL SYSTEMS (I)	(m) the foundation system; elements;
---------------------------------	--------------------------------------

---

( D ) THE HORIZONTAL ZONING SYSTEMS	(i) zoning systems - parallel to the slope; elements; (j) segmental zoning systems; elements (sectors and margins)
---	---

---

( G ) THE INFRA-STRUCTURAL SYSTEMS	(o) wet cores; elements; (p) the ventilation systems (natural and mechanical); elements; (q) pedestrian and vehicular circulation pattern on the site;
---------------------------------------	--

---

( E ) PRELIMINARY DESIGN DECISIONS-THE ALLOCATION OF 'PARTS' TO THE DIAGONAL ZONES	(k) the elements of the rear zone and the 'buffer' margin; elements; (l) the 'parts' of the front terraces zone.
---	---

---



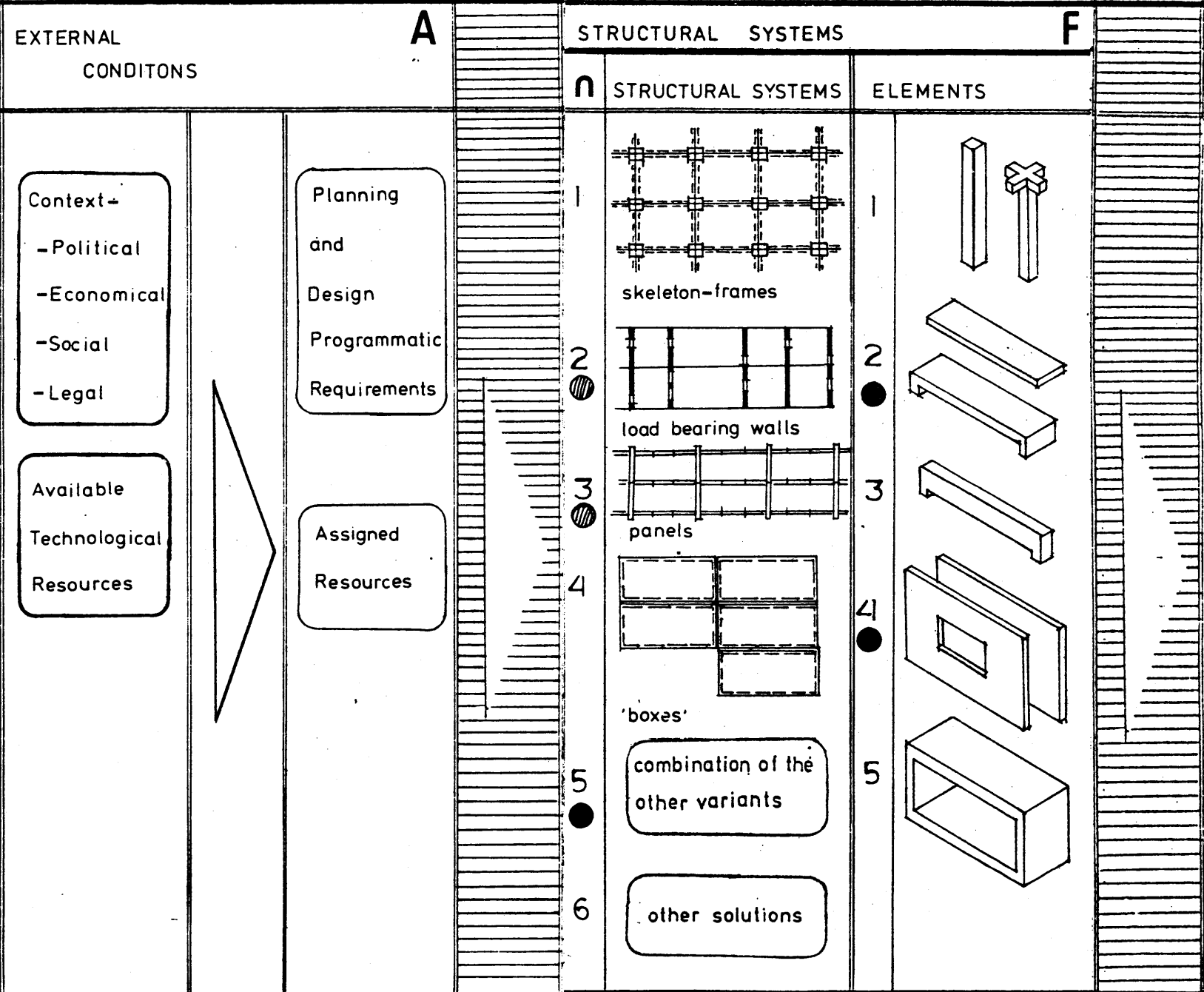

SITE CONDITIONS **B**

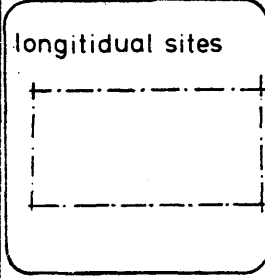
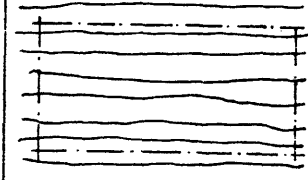
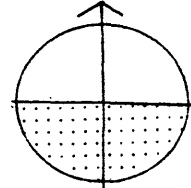
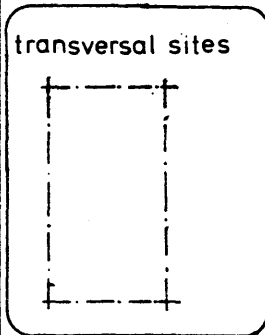
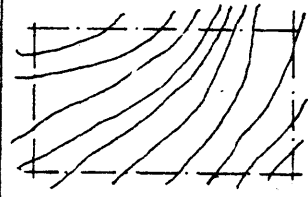
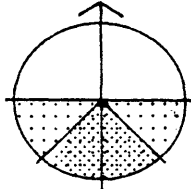
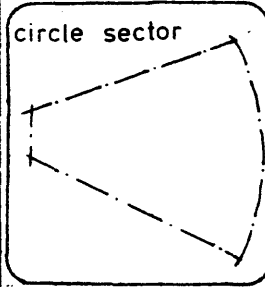
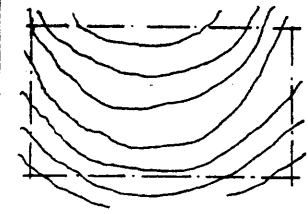
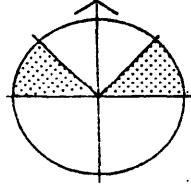
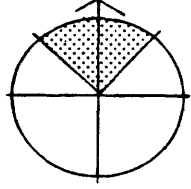
a SLOPE ANGLE	b SOIL CONDITIONS	c SITE BOUNDARIES - MORPHOLOGY	d SLOPE CONTOUR LINES DIRECTION	e ORIENTATION TO THE SUN
1 moderate $6^{\circ}(10\%) - 14^{\circ}(25\%)$	1 rocky soil	1 longitudinal sites 	1  parallel to the site boundaries	1  acceptable
2 medium $14^{\circ}(25\%) - 22^{\circ}(40\%)$	2 safe - stabilized soil	2 transversal sites 	2  diagonal	2  preferred
3 steep $22^{\circ}(40\%) - 45^{\circ}(100\%)$	3 unsafe unstabilized soil cond.	3 circle sector 	3  curved	3  inferior
4 above $45^{\circ}$	4 unsafe unstabilized soil cond.	4 combination of the other variants	4 combination of the other variants	4  undesired

**B**

THE BUILDING TYPE

**f** CONNECTION TO URBAN  
ROADS & TRANS NETWK

**9** GENERIC TYPES

SUB-TYPES



1 ●

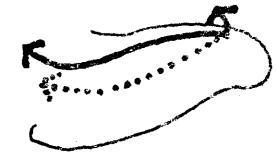

2

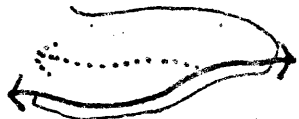

3

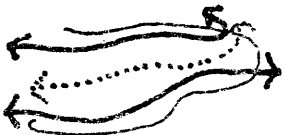

4



5

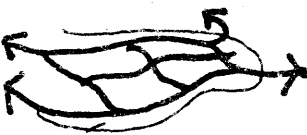

6

combination of the  
other variants

2 ●

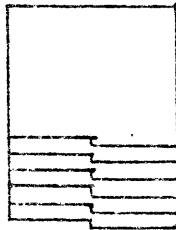

3

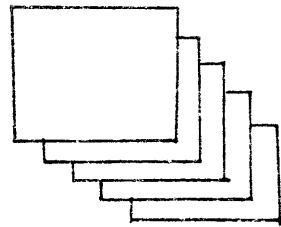

4

combination of the  
other variants

2

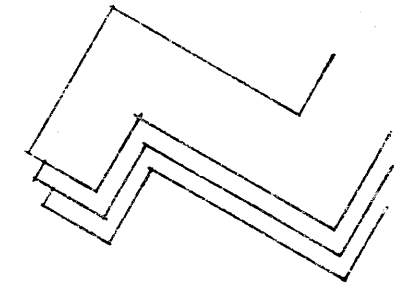

3 ○

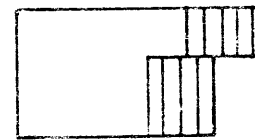

4 ●

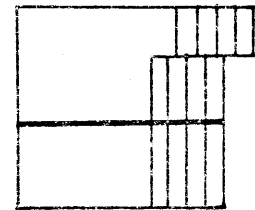

STRUCTURAL SYSTEMS

m FOUNDATION SYSTEMS

anchoring

1

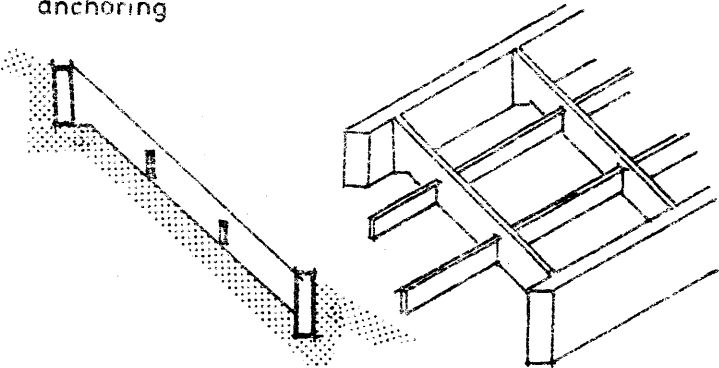

2  
O

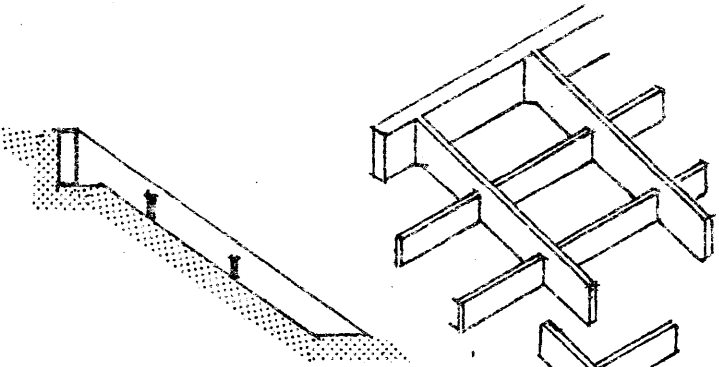

3

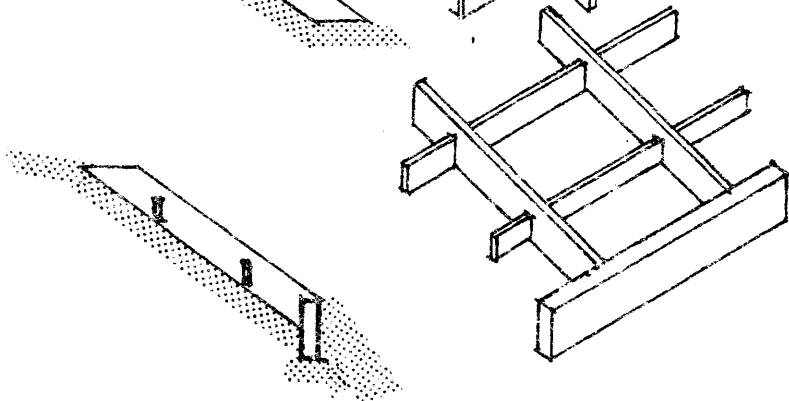

4

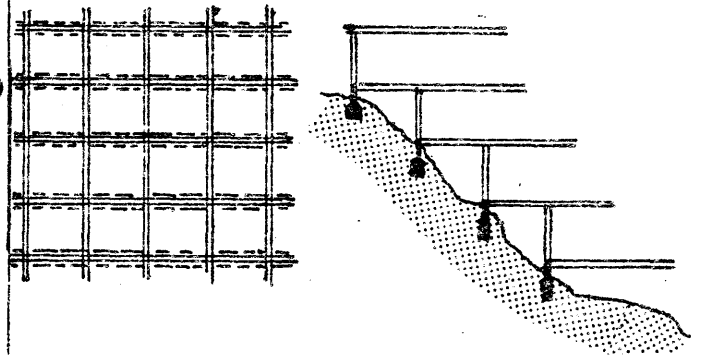

5

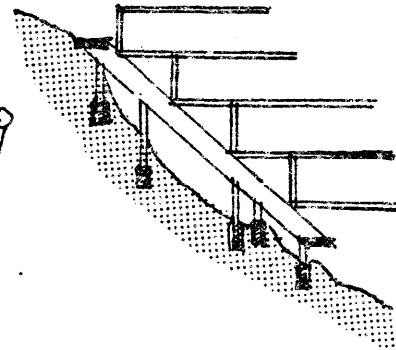
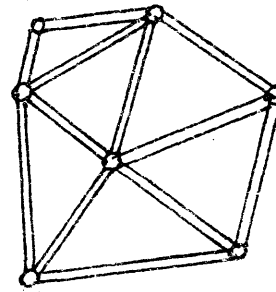

6

combination of the other variants

7

other solutions

C

**h** SCHEMATIC CONCEPT OF THE BUILDING RELATION TO THE NATURAL SLOPE

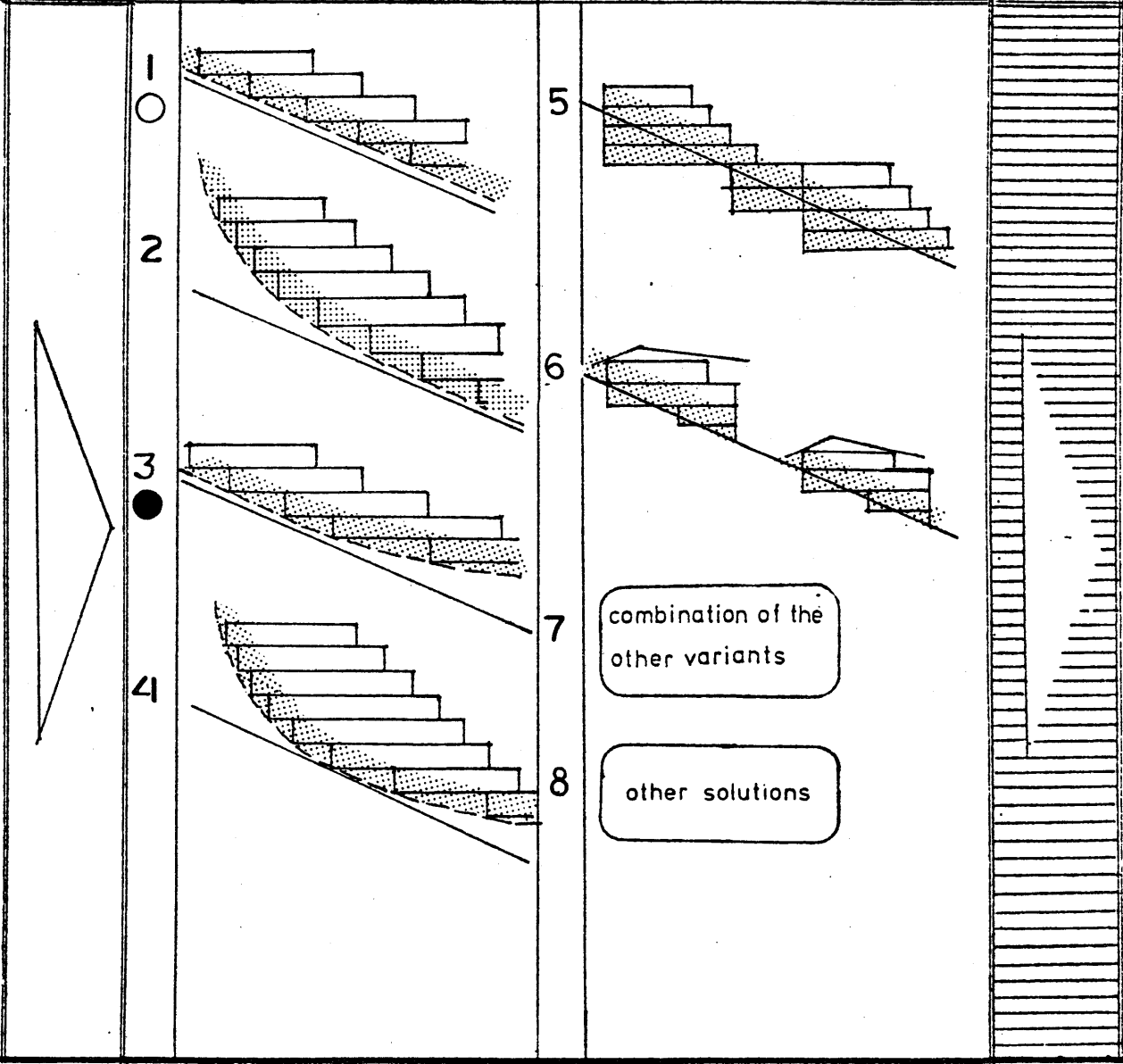

THE ZONING SYSTEMS - HORIZONTAL

D

**i** GENERIC-PARALLEL TO SLOPE-ZONING SYS.

ELEMENTS :

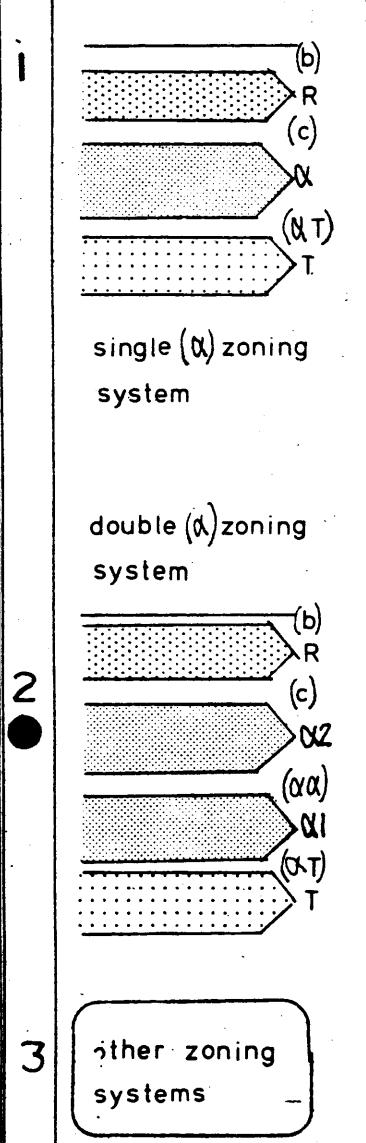

**j** SEGMENTAL ZONING

ELEMENTS :

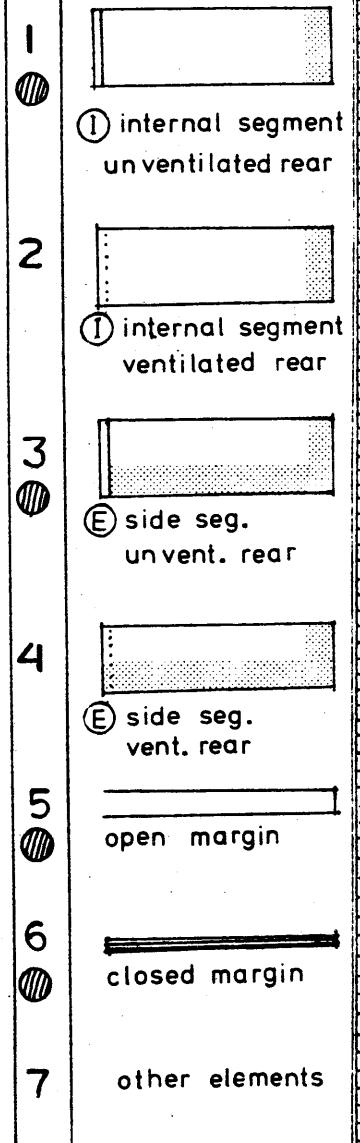
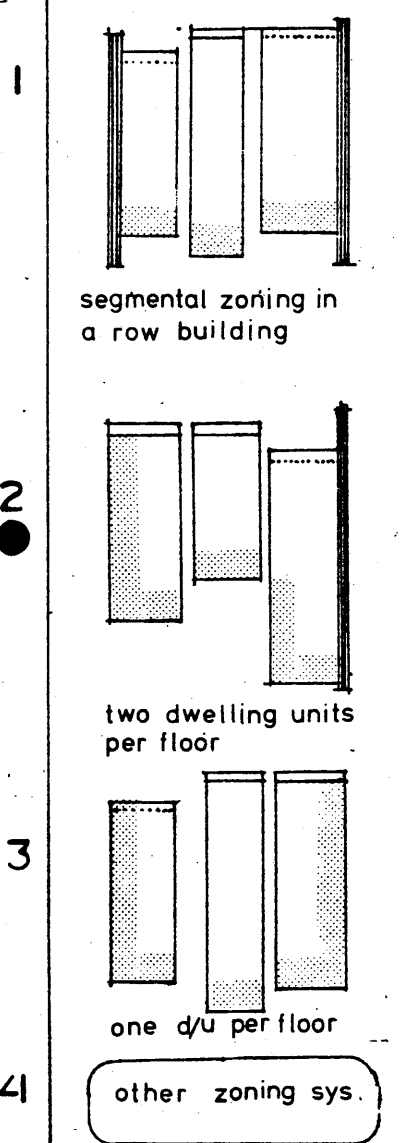





2 ●

3

2 ●

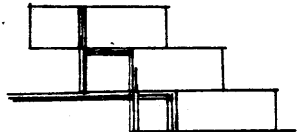
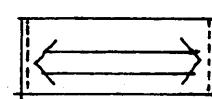
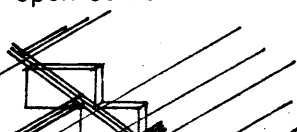
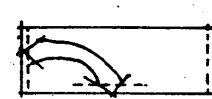
3

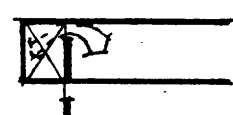
4

INFRA STRUCTURAL SYSTEMS				G	
O	WET CORES	ELEMENTS	P	VENTILATION SYSTEMS	ELEMENTS
1 ●	internal cores sys.	1 	1 ●	natural vent.	1 full cross vent. 
2 ○	external cores sys.	2 open cores 	2	mechanical vent.	2 partial cross vent. 
3 ○	combination of the other variants	3 closed in ducts 	3	combination of the other variants	3 rear tunnel vent. system 
4	other solutions	4 in the front zone (external)			4 vent. by a split level 
		5 on the side elevation (ext.)			5 individual a/c units for rooms or dwel. unit
		6 in the rear zone			6 central a/c sys.
		7 combination of the other variants			7 other
		8 other solutions			

INFRA STRUCTURAL SYSTEMS

ELEMENTS

1  
○



2  
●

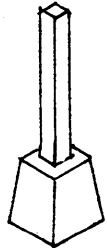

3  
●

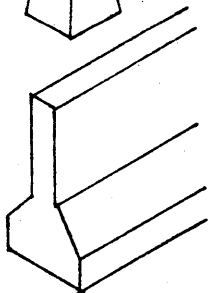

4  
●

combination of the other variants

5

other solutions

9 CIRCULATION SYSTEMS

1 external stairs paths

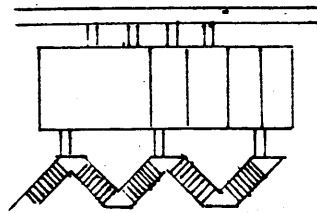

2 ●

network of horizontal and stair paths (external)

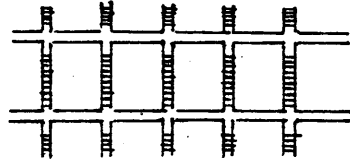

3

diagonal network of reduced angle (slope) paths

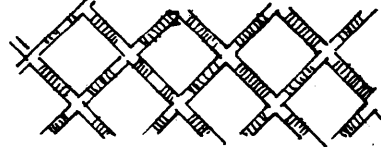

4

5

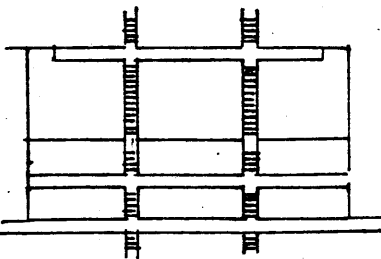

a network of horizontal and stair paths (internal)

6

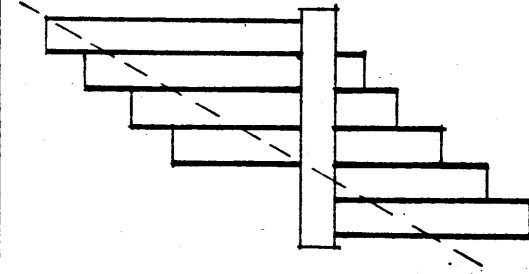

mechanical-vertical elevators

7

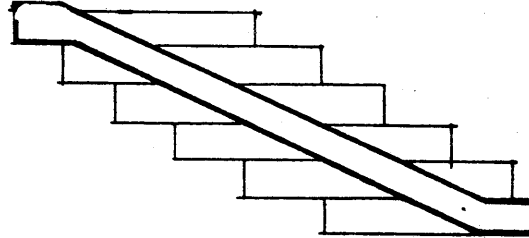

mech.-inclined elevators

8

combination of the other variants

9

other solutions

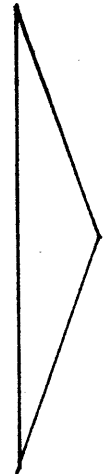



PRELIMINARY DESIGN DECISIONS - THE ALLOCATION OF GENERIC BUILDING PARTS TO

**k** THE REAR ZONE AND BUFFER ELEMENTS (ALT.)

1

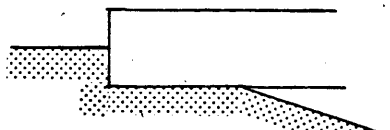

2

○

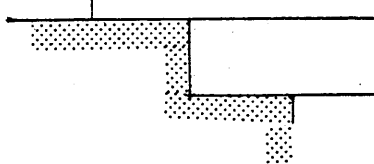

3

○

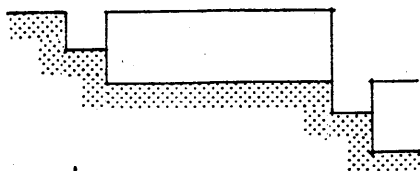

4

●

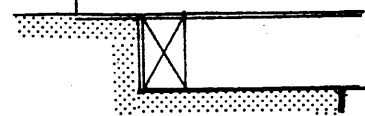

'buffer' margin

5

●

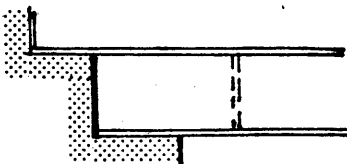

buffer rear zone  
(functional space)

6

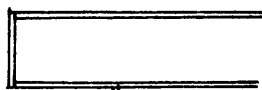

7

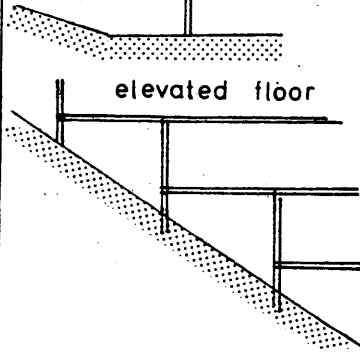

8

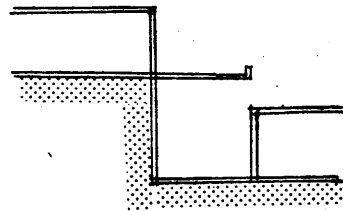

9

**L** THE FRONT-TERRACES ZONE

1

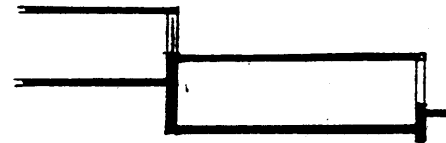

not usable

2

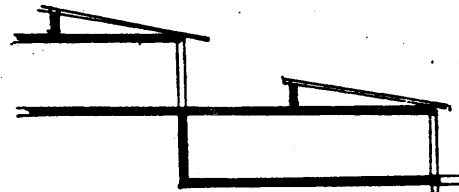

partially used

3

○

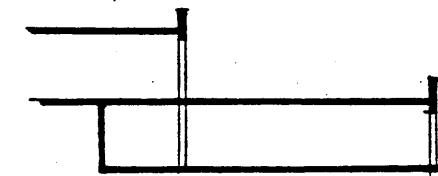

fully used

4

○

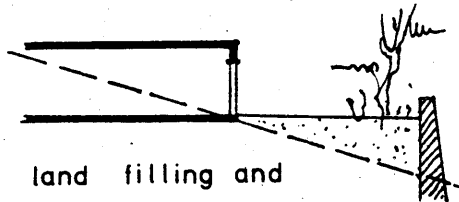

land filling and  
retaining walls

THE DIAGONAL ZONES

E

H

ELEMENTS

5

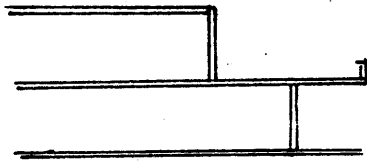

6

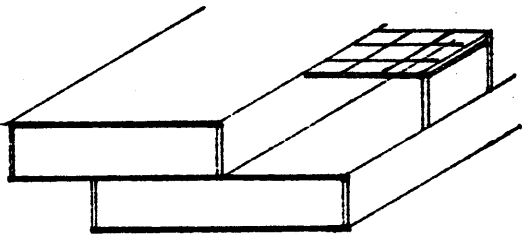

partially roofed terrace

7

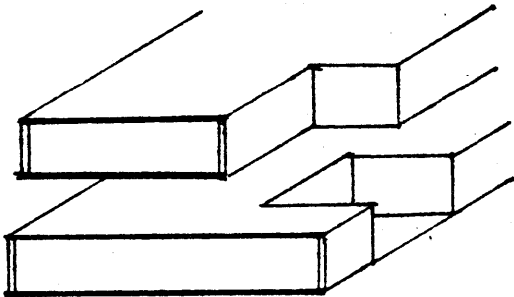

patio terraces

8

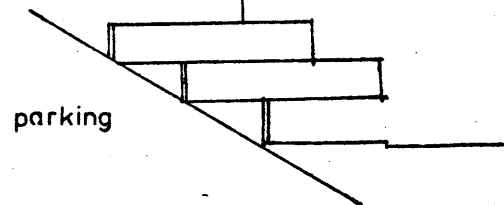

parking

9

function analysis

analysis of the building sectors

allocation and positioning of the residential functions in the interior spaces

specific detailed design

EXECUTION

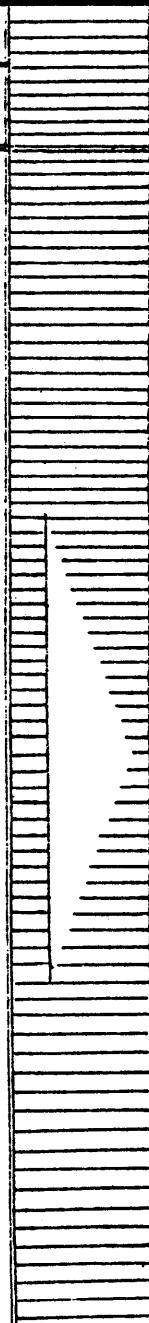

THE 'MORPHOLOGICAL BOX' FOR TERRACE HOUSES - PARAMETERS & VARIANTS LIST - NOTATION

	PARAMETERS	VARIANTS									PARAMETERS	VARIANT no.								
		1	2	3	4	5	6	7	8	9		1	2	3	4	5	6	7	8	9
(A)	EXTERNAL CONDITIONS										(E)	ALLOCATION OF 'PARTS' TO THE DIAGONAL ZONES								
(B)	SITE CONDITIONS										k	the rear zone & 'buffer' elements	■	■	■	■	■	■	■	■
a	the slope angle	■	■	■							l	the front terraces zone elements	■	■	■	■	■	■	■	■
b	soil conditions	■	■	■							(F)	THE STRUCTURAL SYSTEMS								
c	site boundary lines-morphology	■	■	■							m	foundation systems / elements	■	■	■	■	■	■		
d	slope contour lines-direction	■	■	■							n	structural systems / elements	■	■	■	■	■	■		
e	orientation to the sun	■	■	■							(G)	INFRASTRUCTURE SYSTEMS								
f	connection to urban roads & public trans.	■	■	■							o	wet cores / elements	■	■	■	■	■	■		
(C)	THE BUILDING TYPE										p	ventilation system / elements	■	■	■	■	■	■		
g	generic type / elements sub-types	■	■	■							q	circulation system / elements	■	■	■	■	■	■	■	■
h	the relation of the building to the slope	■	■	■							(H)	SPECIFIC DETAILED DESIGN AND EXECUTION								
(D)	THE HORIZONTAL ZONING SYSTEMS																			
i	Parallel to slope zoning / elements	■	■	■																
j	segmental zoning/ elements	■	■	■																

THE 'MORPHOLOGICAL BOX' FOR TERRACE HOUSES - PARAMETERS & VARIANTS LIST - NOTATION

	PARAMETERS	VARIANTS									PARAMETERS	VARIANT no.																	
		1	2	3	4	5	6	7	8	9		1	2	3	4	5	6	7	8	9									
(A)	EXTERNAL CONDITIONS										(E)	ALLOCATION OF 'PARTS' TO THE DIAGONAL ZONES																	
(B)	SITE CONDITIONS										k	the rear zone & 'buffer' elements																	
a	the slope angle										l	the front terraces zone elements																	
b	soil conditions										(F)	THE STRUCTURAL SYSTEMS																	
c	site boundary lines-morphology										m	foundation systems / elements																	
d	slope contour lines-direction										n	structural systems / elements																	
e	orientation to the sun										(G)	INFRASTRUCTURE SYSTEMS																	
f	connection to urban roads & public trans.										o	wet cores / elements																	
(C)	THE BUILDING TYPE										p	ventilation system / elements																	
g	generic type / elements sub-types										q	circulation system / elements																	
h	the relation of the building to the slope										(H)	SPECIFIC DETAILED DESIGN AND EXECUTION																	
(D)	THE HORIZONTAL ZONING SYSTEMS										Project; Ullernaasen Oslo																		
i	Parallel to slope zoning / elements										Architect; Anne-Tinne & Mogens Friis																		
j	segmental zoning/ elements										<b>5</b>																		

THE 'MORPHOLOGICAL BOX' FOR TERRACE HOUSES - PARAMETERS & VARIANTS LIST - NOTATION

	PARAMETERS	VARIANTS									PARAMETERS	VARIANT no.								
		1	2	3	4	5	6	7	8	9		1	2	3	4	5	6	7	8	9
(A)	EXTERNAL CONDITIONS										(E)	ALLOCATION OF 'PARTS' TO THE DIAGONAL ZONES								
(B)	SITE CONDITIONS										k	the rear zone & 'buffer' elements	█		█					
a	the slope angle	█									l	the front terraces zone elements		█					█	
b	soil conditions		█								(F)	THE STRUCTURAL SYSTEMS								
c	site boundary lines-morphology	█									m	foundation systems / elements	█							
d	slope contour lines-direction		█								n	structural systems / elements	█							
e	orientation to the sun	█									(G)	INFRASTRUCTURE SYSTEMS								
f	connection to urban roads & public trans.		█								o	wet cores / elements		█				█		
(C)	THE BUILDING TYPE										p	ventilation system / elements	█							
g	generic type / elements sub-types	█									q	circulation system / elements		█						
h	the relation of the building to the slope	█									(H)	SPECIFIC DETAILED DESIGN AND EXECUTION								
(D)	THE HORIZONTAL ZONING SYSTEMS																			
i	Parallel to slope zoning / elements	█																		
j	segmental zoning/ elements		█																	

Project ; Orselina, Locarno, Corsier

Architect ; Erwin Mühlestein

**13**

THE 'MORPHOLOGICAL BOX' FOR TERRACE HOUSES - PARAMETERS & VARIANTS LIST - NOTATION

	PARAMETERS	VARIANTS									PARAMETERS	VARIANT no.								
		1	2	3	4	5	6	7	8	9		1	2	3	4	5	6	7	8	9
(A)	EXTERNAL CONDITIONS										(E)	ALLOCATION OF 'PARTS' TO THE DIAGONAL ZONES								
(B)	SITE CONDITIONS										k	the rear zone & 'buffer' elements								
a	the slope angle	█									l	the front terraces zone elements	█							
b	soil conditions	█									(F)	THE STRUCTURAL SYSTEMS								
c	site boundary lines-morphology	█									m	foundation systems / elements								
d	slope contour lines-direction	█									n	structural systems / elements								
e	orientation to the sun	█									(G)	INFRASTRUCTURE SYSTEMS								
f	connection to urban roads & public trans.	█									o	wet cores / elements								
(C)	THE BUILDING TYPE										p	ventilation system / elements								
g	generic type / elements sub-types	█	█								q	circulation system / elements								
h	the relation of the building to the slope	█									(H)	SPECIFIC DETAILED DESIGN AND EXECUTION								
(D)	THE HORIZONTAL ZONING SYSTEMS																			
i	Parallel to slope zoning / elements		█																	
j	segmental zoning/ elements		█																	

Project; Ithaca housing N.Y.

Architect; Werner

Seligmann and Associates

14

THE 'MORPHOLOGICAL BOX' FOR TERRACE HOUSES - PARAMETERS & VARIANTS LIST - NOTATION

	PARAMETERS	VARIANTS									PARAMETERS	VARIANT no.																	
		1	2	3	4	5	6	7	8	9		1	2	3	4	5	6	7	8	9									
(A)	EXTERNAL CONDITIONS										(E)	ALLOCATION OF 'PARTS' TO THE DIAGONAL ZONES																	
(B)	SITE CONDITIONS										k	the rear zone & 'buffer' elements																	
a	the slope angle										l	the front terraces zone elements																	
b	soil conditions										(F)	THE STRUCTURAL SYSTEMS																	
c	site boundary lines-morphology										m	foundation systems / elements																	
d	slope contour lines-direction										n	structural systems / elements																	
e	orientation to the sun										(G)	INFRASTRUCTURE SYSTEMS																	
f	connection to urban roads & public trans.										o	wet cores / elements																	
(C)	THE BUILDING TYPE										p	ventilation system / elements																	
g	generic type / elements sub-types										q	circulation system / elements																	
h	the relation of the building to the slope										(H)	SPECIFIC DETAILED DESIGN AND EXECUTION																	
(D)	THE HORIZONTAL ZONING SYSTEMS										Project; Zug Suisse																		
i	Parallel to slope zoning / elements										Architect; F. Stucky																		
j	segmental zoning/ elements										& R. Meull																		

(5. ) CONCLUSION

---

The common housing problems on a general level are the wider context of this study, regardless of any specific building type which is used for housing. The general approach for dealing with the housing problem is essentially based on two complementary means; the increasing of the housing users control over the planning and design of their homes and the better employment of various resources which are put into housing mainly by the systematization of that planning and design process with its general implications on the housing 'industry'.

A basic planning and design approach which deals with the housing problems by these means was developed by prof. N.J. Habraken (in **Supports, An Alternative to Mass Housing**), and the dutch S.A.R. group (described in "Variations- a Systematic Design of Supports", and in 'S.A.R 73'). That systematic approach and the planning and design methodology which it evolved serve as the background and a reference base for this study.

This study deals with two basic problem sets on a specific level of the study of terrace houses, and on the general level



of the planning and design process and the way by which it responds to various external conditions. These two problem sets are; - The methodological and structural problems of the planning and design process.

- The methodological and structural problems of an architectural analytic classification study.

These two problem sets are related to each other with respect to a larger rationalization process.

The study was done through a case study of a specific building type which was generalized into the larger context. The structure of the specific analysis, planning and design tools which were yielded by the study of terrace houses were developed with the intention that they will allow generalizations and modifications to accommodate their application in other building types.

The building type which was chosen as a subject of the case study was the terrace houses on sloped sites. This type was chosen as an example of the building types, designed to accommodate extreme external conditions. The extreme site conditions with the planning and design problems which they

generate seemed to help in clarifying the structure of the planning and design process which was studied. The extreme differences which were generated among the variants of the design parameters, helped also in establishing and clarifying the method and the tools/which were applied in this study.

In the methodological-structural study of the planning and design process an effort was made to identify clearly the generic parameters. With clear definitions of these parameters, their interrelations and the dynamics of the process can be studied. Such a study may yield some proposals for increased rationalization of that process, which are aimed for simplifying it, upgrade it's efficiency and make progress towards optimization of it's product.

The initial study of that kind which was completed suggested some explanations and possible solution directions for some of the specific problems of terrace houses. The key for the ability to point out generic problems and solutions lies in the application of the modified version of the 'Morphological Box' method which was established by F.Zwicky. With the application of the morphological box, each example of the

study subject could be easily classified and examined in a larger perspective of the terrace houses design problems. That larger perspective was established by comparison and analysis of the various examples of terrace houses. The identification of each example by its generic characteristics as the variants of the classification study parameters can point out the range of 'legitimate' alternative solutions which was not applied in the specific example. If the main points of the planning and design process is known (like a general description of the design steps etc,) some explanation can be made as to why and how a specific alternative was generated and chosen. This tracking back of the design process can also point out what would the chosen alternative probably be in different external conditions and in different organization of the planning and design sequence.

In this study the S.A.R. approach to the housing problems was carried out in the following manner ;

- The basic structure of the planning and design and its main elements had been identified, with some understanding of this process dynamics.

- The classification and analysis study identified the generic physical elements of terrace building as a case study. From these generic elements, the 'support' elements can be sorted out. This study provided also the tools which may indicate the compatibility between the various potential 'support' elements.
- The zoning system which was developed specifically for terrace houses is essentially an adaptation of the dutch zoning system (as developed by the S.A.R. group) to the requirements of the sloped sites and the terrace building type. The zoning system which is parallel to the slope is applying the same 'rules' as the dutch zoning. In addition, the specific positional problems of terrace houses and their internal elements with respect to the slope, generated the segmental zoning. An additional study is required to determine more clearly that zoning system which is common in many building types (which are not row building as in the dutch houses). Relatively to the dutch system, that space ordering system seems to function as a mixture of the characteristics of the simple zones and the 'sectors'.

- The diagonal zones which were proposed in this study as design tools which are specifically responding to some design problems of terrace houses. This diagonal zoning system divides the building into three inclined zones which refer independently to three distinct problems sets (as the relation of the building to the slope in the rear diagonal zone). The study of these diagonal zones went as far as recognizing and identifying them and their elements. The proposed steps ahead are to establish a systematic functional and zoning analysis for these zones to gain a better understanding of their characteristics.

The proposal of the three zoning systems for terrace houses was the deepest 'stab' of this study in the the design problems of the 'support' level of housing planning, as it was established by the S.A.R. methodology. The rest of the design tools of the S.A.R. approach and methodology (as the function and sector analysis or the generating of various 'basic variants') is proposed for additional study in the future.

This study was initiated with the intention to get a better understanding of the rationalization and systematization of the planning and design process. The terrace houses on slopes have been chosen as a case study besides having their independent relevance to be the subject of a systematic study.

During the information gathering stage and the first analytical steps the method of the study and to some extent even the desired 'final product' were somewhat vague. They became clearer after proceeding with some systematic attempts 'to make sense out of them'. It is believed that the final results indicate the advantages which can be provided by a systematic-rational approach to the planning and design process.

The specific case of rationalization of the terrace houses remained in the state of proposing some design tools, guidelines and developing some partial examples. These results are satisfactory as it was not the intention of this study to provide better design examples nor to concentrate mainly on terrace houses, but to provide some deeper understanding of the planning and design process and its rationalization.

BIBLIOGRAPHY LIST

---

- Habraken N.J. "Supports, An Alternative to Mass Housing"  
New York Praeger, 1972
- Habraken N.J. , J.T. BOEKHOLT, A.P Thijssen PJM Dinjens;  
"Variations - The Systematic Design of Supports"  
M.I.T. Laboratory of Architecture and Planning,  
Cambridge Mass. 1976
- Donald P. Grant, , "How to Construct a Morphological Box"
- Donald P. Grant, "How to Construct a Morphological Tree"
- Harald Deilman, Jorg C. Kirschenmann, Herbert Pfeiffer,  
"The Dwelling",  
Karl Kramer Verlag, Stuttgart, 1973.
- Karl Heinz Benkert "Terrassenhauser am Hang"  
Deutsche Verlags-Anstalt , 1974
- Ot Hoffmann Christoph Repenthin  
Neue Urbane Wohnformen (Gartenhofhauser,  
Teppichsiedlungen, Terrassenhauser)  
Bertlesmann Fachverlag , Berlin 1965
- Gerhard Schwab, Mehrfamilienhauser  
Deutsche Verlags-Anstalt GmbH Stuttgart 1964

- Christof Riccabona , Michael Wachberger  
Terrassenhauser (E+P, No.14) (Entwurf und Planung)  
Verlag Georg D.W.Callwey , Munchen 1972.
- Reyner Banham, "Theory and Design in the First Machine Age",  
The Architectural Press ,London, 1960
- Michael Franklin Ross, "Beyond Metabolism, The New Japanese Architecture",  
Architectural Record Books, N.Y. 1978
- Riba Publications, " A Language and a Theme, The Architecture of  
Denys Ladsun & Partners "  
London 1976
- Prof. Zalewski, Building on Slopes, An Approach  
M.I.T 1969