

**TOWARD THERMAL MANAGEMENT OF DEFORMATION
BEHAVIOR IN UNIAXIAL
THERMOPLASTIC COMPOSITES**

by

Timothy W. Hyland

SUBMITTED TO THE DEPARTMENT OF MECHANICAL
ENGINEERING IN PARTIAL FULFILLMENT OF THE
REQUIREMENTS FOR THE DEGREE OF
BACHELOR OF SCIENCE

at the

MASSACHUSETTS INSTITUTE OF TECHNOLOGY

May 1988

Copyright © 1988 Massachusetts Institute of Technology

Signature Redacted

Signature of Author _____

Department of Mechanical Engineering
May 27, 1988

Signature Redacted

Certified by _____

Professor Timothy G. Gutowski
Thesis Supervisor

Signature Redacted

Accepted by _____

Professor Peter Griffith
Chairman, Undergraduate Thesis Committee

MASSACHUSETTS INSTITUTE
OF TECHNOLOGY

JUN 13 1988
ARCHIVES

LIBRARIES

TOWARD THERMAL MANAGEMENT OF DEFORMATION BEHAVIOR IN UNIAXIAL THERMOPLASTIC COMPOSITES

by

Timothy W. Hyland

Submitted to the Department of Mechanical Engineering on May 27, 1988 in partial fulfillment of the requirements for the degree of Bachelor of Science.

Abstract

This project's aim was to explore ways of thermally managing the deformation behavior of a uniaxial Advanced Thermoplastic Composite (ATC) during forming. When a uniaxial composite is pulled or compressed off axis, its anisotropic properties cause it to deform non-uniformly and shear. Selectively heating regions of a simple thermoplastic sheet induces an anisotropy that is similar to the anisotropy in an ATC. By applying this heating method to a uniaxial ATC, it may be possible to induce an anisotropy that will "cancel out" the natural anisotropy of the composite in tensile deformation. Two major obstacles kept the technique from being demonstrated in an ATC. The first problem was that the softened uniaxial ATC would fail before any appreciable deformation could occur. This tearing occurs between the fibers of the composite, where there is little polymer matrix to hold it together. The second problem was that high thermal gradients in the composite were required for the technique, but heat conduction through the fibers reduced the temperature gradient substantially.

Thesis Supervisor:
Title:

Professor Timothy G. Gutowski
Alcoa Associate Professor of Mechanical Engineering

Dedication

Thanks to the engineers at Du Pont for their time and support. Thanks to Prof. Tim Gutowski for his guidance. Thanks to Julian Macri, Michael Ni, and Michael Sentovich for their help. Thanks especially to Mom and Dad, without whom, none of this would have been possible. But most of all, thanks to Tim Eicher for his love and support.

Table of Contents

Abstract	2
Dedication	3
Table of Contents	4
List of Figures	6
List of Tables	7
1. Introduction	8
1.1 Background	8
1.2 Overview	10
1.3 Breakdown of the Thesis	12
2. Theory	13
2.1 Anisotropy in a Uniaxial Composite	13
2.2 Heat Transfer in a Thermoplastic Sheet	15
2.3 Heat Transfer in a Composite	18
3. Experimental Methods	19
3.1 Materials	19
3.2 Material Samples	20
3.3 Heating Methods	21
3.3.1 Infrared heating	21
3.3.2 Ohmic heating	22
3.3.3 Heating times	22
3.4 Testing Equipment	23
3.4.1 Pulling rate	23
4. Experiments On Thermoplastic Sheet	24
4.1 The Use of Acrylate	24
4.2 Experimental Procedure	25
4.2.1 Heating with IR lamp and foil mask	25
4.2.2 Heating with ohmic heating wires	25
4.3 Results of Tests on Thermoplastic Sheet	27
4.3.1 Heating with IR lamp and foil mask	27
4.3.2 Heating with ohmic heating wires	28
4.4 Interpretation of Results	30
5. Demonstration of Shear in an ATC	32
5.1 The Use of Polypropylene/Glass ATC	32
5.1.1 Experimental Procedure	33
5.1.2 Results	33
5.2 Use of Kevlar/J2 ATC	35
5.2.1 Experimental procedure	35
5.2.2 Results	36
5.3 Use of Polypropylene/Glass ATC with Polypropylene Core	37
5.3.1 Experimental procedure	38
5.3.2 Results	38

5.4 Interpretation of Results	40
6. Controlling Anisotropic Deformation in an ATC	41
7. Suggestions for Further Research and Conclusions	43
7.1 Further Research	43
7.2 Conclusion	44
Appendix A. Heat Conduction in an Infinite Plate, Solution	45
Appendix B. Mold for Consolidating Polypropylene/Glass Pre-Preg	47

List of Figures

Figure 1-1:	Shear deformation of a uniaxial composite in off-axis tension	9
Figure 1-2:	Thermally induced anisotropy in a thermoplastic sheet	10
Figure 1-3:	Thermally induced anisotropy superimposed on an off-axis ATC	11
Figure 2-1:	Heating of bands in a thermoplastic sheet, idealized and simplified	15
Figure 2-2:	Plot of non-dimensional temperature in an infinite plate	17
Figure 4-1:	Plexiglass coupon with grid and foil mask	26
Figure 4-2:	Ohmic heating device (from toaster)	26
Figure 4-3:	Pulled plexiglass coupons, heated with IR lamp and foil mask	28
Figure 4-4:	Pulled Plexiglass coupons, heated with IR lamp and ohmic unit	29
Figure 4-5:	Comparison of heating methods on Plexiglass coupons	31
Figure 5-1:	Pulled polypropylene/glass ATC samples	34
Figure 5-2:	Pulled Kevlar/J2 samples	36
Figure 5-3:	PPGL samples with cores of polypropylene	38
Figure 5-4:	Pulled samples of PPGL ATC with polypropylene core	39

List of Tables

Table 3-I:	Material Sample Properties	20
Table 4-I:	Results of tests on Plexiglass samples	31
Table 5-I:	Results of experiments to demonstrate shear in ATC samples	40

Chapter 1

Introduction

Advanced composite materials have been in use for a number of years and are finding more applications everyday. Composites are often made with glass or carbon fibers imbedded in thermosetting matrices, such as epoxy. Recently thermoplastic matrices have been used more often because of their flexibility in processing. New fibers have also been developed and are used in these Advanced Thermoplastic Composites (ATC's), such as Kevlar®. Along with the development of the materials, new processing methods must be developed. This thesis discusses the research of a novel processing method for uniaxial composites. The process uses localized heating to thermally manage the deformation of a uniaxial ATC that is being pulled in tension.

1.1 Background

When a uniaxial composite is pulled or compressed in a direction that is at an angle to the fiber orientation, its anisotropic properties cause it to deform non-uniformly. It is the goal of this work to investigate the effects of thermally inducing an opposing anisotropic behavior. In this way the unwanted shear deformation may be controlled and eliminated on macroscopic scale.

If a section of uniaxial composite is pulled with the axis of the fibers at an angle to the direction of tension, it will not deform the way an isotropic material will deform. Instead of extending in the direction of the tension, it will try to extend in the direction perpendicular to the fiber direction. See Fig. 1-1. This causes shearing to take place, distorting the composite as it is being pulled. It may be possible to control this phenomenon by "convincing" the composite to shear the opposite way using localized heating. Hence, the two defor-

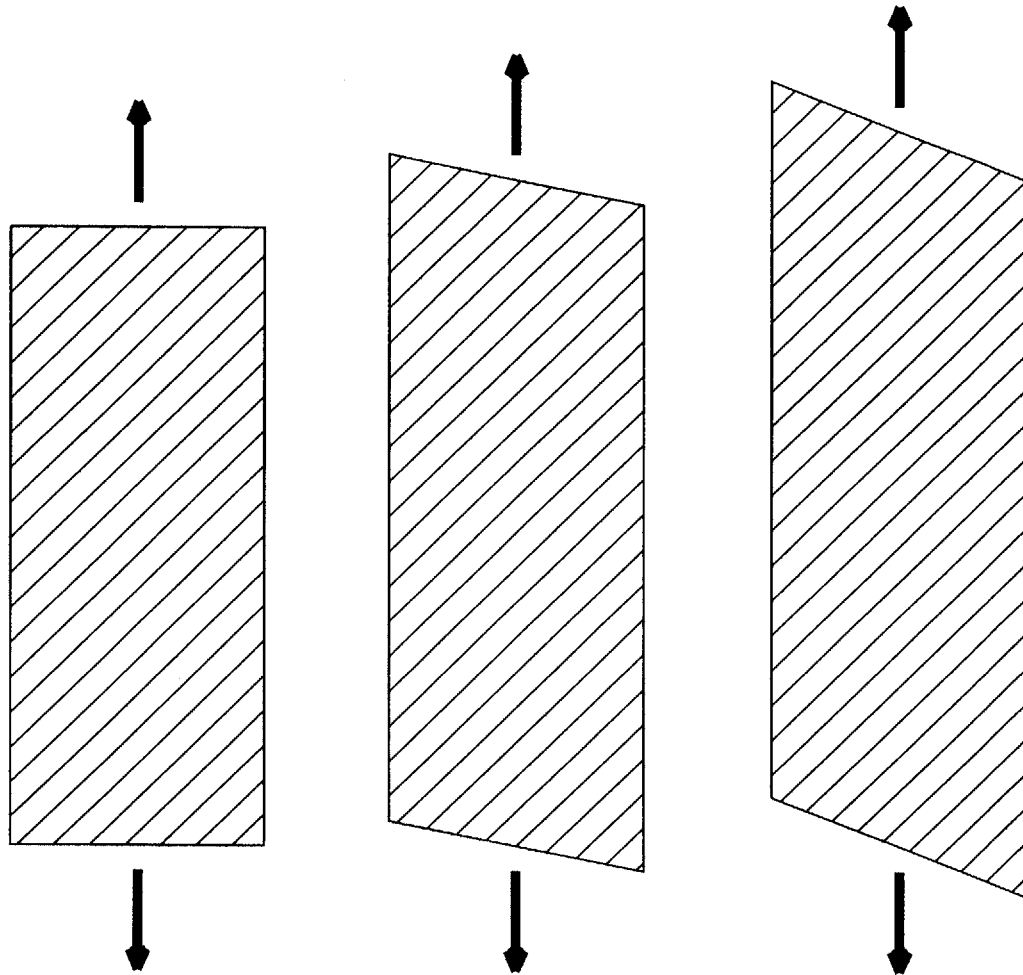

Figure 1-1: Shear deformation of a uniaxial composite in off-axis tension
mations will "cancel" each other, producing (macroscopic) isotropic behavior when the composite is pulled.

It is possible to induce anisotropic behavior in a thermoplastic sheet. If alternate bands or strips in the thermoplastic sheet are heated to a temperature above its glass transition point, leaving cooler bands in between, an incremental anisotropy will be created. If this thermoplastic sheet is now stretched such that the heated bands are at an angle to the direction of tension, a shear deformation will occur. This shear deformation will be very similar in nature to the shear deformation found in uniaxial composites. See Fig. 1-2.

By applying this heating method to a uniaxial ATC, such that the heated regions are

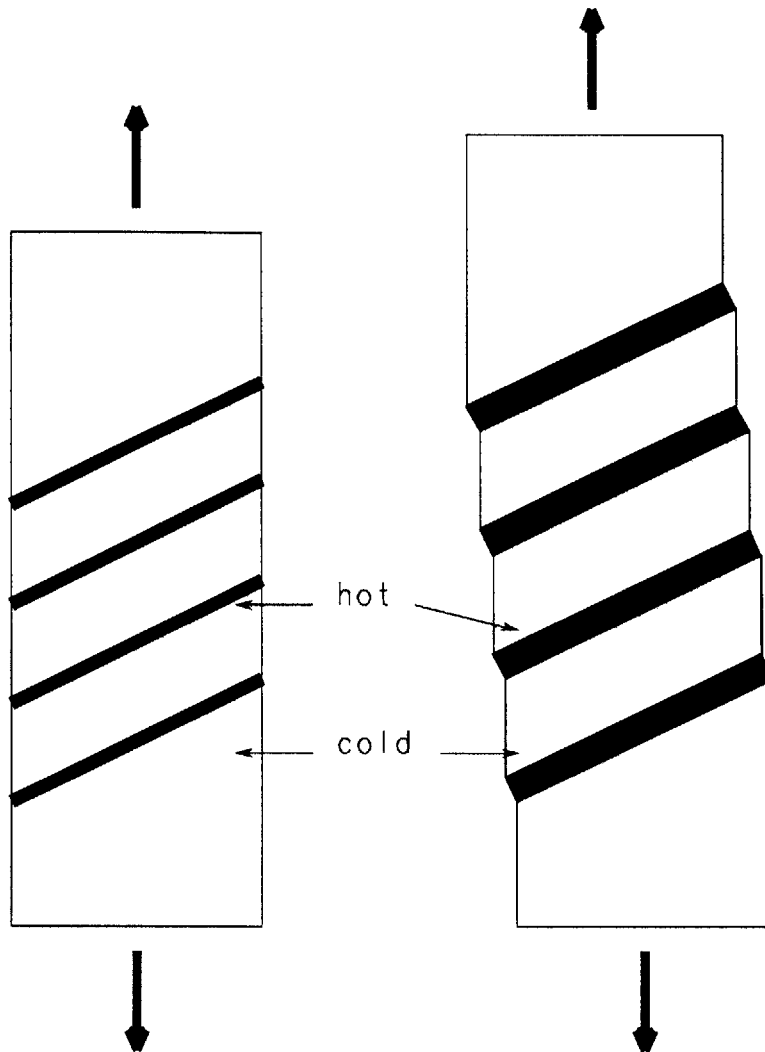

Figure 1-2: Thermally induced anisotropy in a thermoplastic sheet perpendicular to the fiber direction, the two anisotropic behaviors should cancel each other. Thus, the deformation of the composite can be controlled thermally. See Fig. 1-3.

1.2 Overview

The initial research was conducted on simple amorphous thermoplastic sheet, specifically acrylate. The goal of this research was to explore methods of heating and to develop models to predict the temperature distribution in the cool regions of the sample coupon.

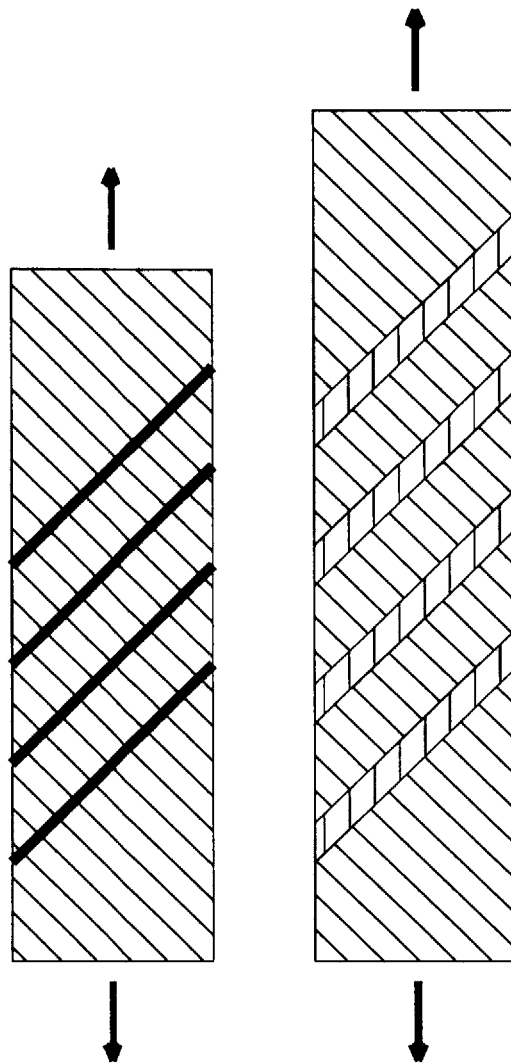

Figure 1-3: Thermally induced anisotropy superimposed on an off-axis ATC

Once the methods of heating were understood in the thermoplastics, the knowledge was applied to ATC's. The research was done qualitatively, rather than quantitatively.

In applying this method to ATC's it was found that there were two main obstacles preventing the control of the anisotropy. The first was that the softened composite sample would tear between fibers before any appreciable deformation could occur. In other words, there was little or no shear deformation to cancel in many cases. This was overcome by increasing the amount of polymer matrix in the composite, but there was a second obstacle.

The second obstacle was the problem of heat transfer between the cool and hot regions of the composite. To get the maximum effect from this heating method, high temperature gradients are required. However, in the time that it takes to heat a region to a high enough temperature, heat has been conducted to the cool region, reducing the temperature gradient. Thus, the hot regions and the cool regions are actually both hot regions and there is very little anisotropy in the sample.

1.3 Breakdown of the Thesis

The theories behind the thermal management techniques are discussed in the next chapter. Also discussed are the issues of heat transfer and failure of uniaxial composites. Chapter 3 contains information about the materials and procedures used in the experiments. Chapters 4, 5, and 6 contain information about the actual experiments and the last chapter has a conclusion and suggestions for further research.

Chapter 2

Theory

2.1 Anisotropy in a Uniaxial Composite

One of the many odd properties of a uniaxial composite is the coupling between shear strain and normal stress and between shear stress and normal strain. Equations (2.1), (2.2), and (2.3) show the stress strain relation in a uniaxial composite for an arbitrary rotation of the primary material coordinates (**1,2** coordinates) with respect to the geometric coordinate system (**X,Y** coordinate system). (Jones, 1975) The **1,2** coordinate system refers to the material axes, with **1** being parallel to the fibers and **2** perpendicular to the fibers. The **X,Y** coordinate system refers to the frame of reference in which the composite is located. The angle θ is the angle that the **X,Y** coordinate system must be rotated to coincide with the **1,2** coordinate system.

$$\begin{Bmatrix} \epsilon_x \\ \epsilon_y \\ \gamma_{xy} \end{Bmatrix} = \begin{bmatrix} \bar{S}_{11} & \bar{S}_{12} & \bar{S}_{16} \\ \bar{S}_{12} & \bar{S}_{22} & \bar{S}_{26} \\ \bar{S}_{16} & \bar{S}_{26} & \bar{S}_{66} \end{bmatrix} \begin{Bmatrix} \sigma_x \\ \sigma_y \\ \tau_{xy} \end{Bmatrix} \quad (2.1)$$

$$\begin{aligned} \bar{S}_{11} &= S_{11}\cos^4\theta + (2S_{12} + S_{66})\sin^2\theta\cos^2\theta + S_{22}\sin^4\theta \\ \bar{S}_{22} &= S_{12}(\sin^4\theta + \cos^4\theta) + (S_{11} + S_{22} - S_{66})\sin^2\theta\cos^2\theta \\ \bar{S}_{22} &= S_{11}\sin^4\theta + (2S_{12} + S_{66})\sin^2\theta\cos^2\theta + S_{22}\cos^4\theta \\ \bar{S}_{16} &= (2S_{11} - 2S_{12} - S_{66})\sin\theta\cos^3\theta - (2S_{22} - 2S_{12} - S_{66})\sin^3\theta\cos\theta \\ \bar{S}_{16} &= (2S_{11} - 2S_{12} - S_{66})\sin^3\theta\cos\theta - (2S_{22} - 2S_{12} - S_{66})\sin\theta\cos^3\theta \\ \bar{S}_{66} &= 2(2S_{11} + 2S_{22} - 4S_{12} - S_{66})\sin^2\theta\cos^2\theta + S_{66}(\sin^4\theta + \cos^4\theta) \end{aligned} \quad (2.2)$$

$$\begin{aligned} S_{11} &= \frac{1}{E_1} \\ S_{12} &= \frac{-\nu_{12}}{E_1} = \frac{-\nu_{21}}{E_2} \\ S_{22} &= \frac{1}{E_2} \\ S_{66} &= \frac{1}{G_{12}} \end{aligned} \tag{2.3}$$

The fact that the \bar{S}_{16} and \bar{S}_{26} components of the compliance matrix $[\bar{S}]$ are non-zero indicates coupling between shear strain and normal stress. This means that when the composite is stressed in the X direction, it will deform in shear. This is the phenomenon that causes the distortion to take place in the composite samples when they are heated and stretched.

In Equations (2.3), E_1 is the Young's modulus of the composite in the direction of the fibers. It can be approximated as a function of the fiber volume fraction, the matrix volume fraction, and the Young's moduli of the fibers and matrix. This relationship is shown in Equation (2.4).

$$E_1 = V_f E_f + V_m E_m \approx V_f E_f \tag{2.4}$$

The matrix component is negligible compared to the fiber component. Similarly, E_2 can be approximated with the equation

$$\frac{1}{E_2} = \frac{V_f}{E_f} + \frac{V_m}{E_m} \approx \frac{V_m}{E_m} \tag{2.5}$$

In this case, the component due to the fibers is negligible because of the high strength of the fibers.

The material properties G_{12} and ν_{12} are given by Equations (2.6) and (2.7). (Gutowski, 1983)

$$G_{12} = \frac{G_m(1 + 2\eta V_f)}{1 - \eta V_f} \quad \eta = \frac{(G_f/G_m) - 1}{(G_f/G_m) + 2} \quad (2.6)$$

$$v_{12} = (1 - V_f)v_m + V_f v_f \quad (2.7)$$

In these equations, G_m , G_f , v_m , and v_f are material properties of the fibers and matrix.

2.2 Heat Transfer in a Thermoplastic Sheet

Heating bands in a sheet of thermoplastic will cause the cool regions to get warm in addition to the heated regions. Figure 2-1A displays the idealized case of heating two regions in a thermoplastic sheet. The regions are being heated by a constant heat flux, q . There are a few assumptions in this case: heat loss from the cool regions due to convection or radiation is negligible and the heat flow in the sheet is one dimensional. The problem can be further simplified as pictured in Figure 2-1B. Here, the central cool region in Figure 2-1A is approximated as an infinite plate, because of the one dimensional heat flow assumption. The heat flux q_0 is the heat being conducted from the heated regions on either side of the cool region.

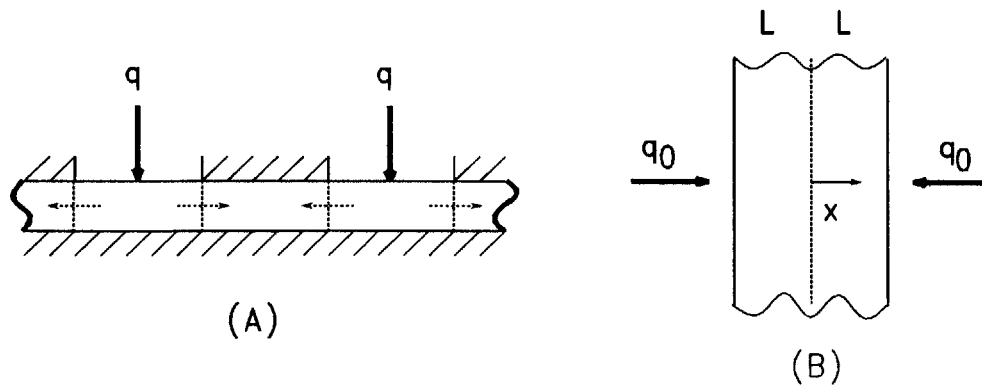

Figure 2-1: Heating of bands in a thermoplastic sheet, idealized and simplified

In this simplified ideal case, the plate (cool region) is $2L$ thick, and the coordinate x is measured from the center of the plate. The temperature distribution as a function of x and time can be found in this infinite plate, subject to a constant heat flux. The heat diffusion equation for one dimensional heat flow is:

$$\frac{d^2t}{dx^2} = \frac{1}{\alpha} \frac{dt}{d\tau} \quad (2.8)$$

Boundary conditions for this problem are:

$$t = t_i \text{ for } -L < x < +L \text{ at } \tau = 0.$$

$$q = q_0 \text{ for } x = \pm L \text{ at } \tau > 0.$$

Where t is temperature, τ is time, q is heat flux, and α is the thermal diffusivity. The solution to this problem is as follows. (VanSant, 1983)

$$\frac{(t-t_i)k}{q_0L} = Fo + \frac{X^2}{2} - \frac{1}{6} - 2 \sum_{n=1}^{\infty} \frac{(-1)^n}{\lambda_n^2} \exp(-\lambda_n^2 Fo) \cos(\lambda_n X) \quad (2.9)$$

$$\lambda_n = n\pi$$

$$Fo = \frac{\alpha\tau}{L^2}$$

$$X = \frac{x}{L}$$

Where, k is the thermal conductivity, X is the length ration, and Fo is the Fourier Modulus. This equation can be solved numerically.

A FORTRAN program was used to solve this equation. See Appendix A for a listing of the code. The code was written to solve for the generic case of a plate one meter thick, with a thermal diffusivity of $\alpha = 0.001 \text{ M}^2/\text{s}$. The program solves for the non-dimensional temperature that is the left side of Equation (2.9). The resulting output is plotted in Figure 2-2.

Conduction in an infinite plate

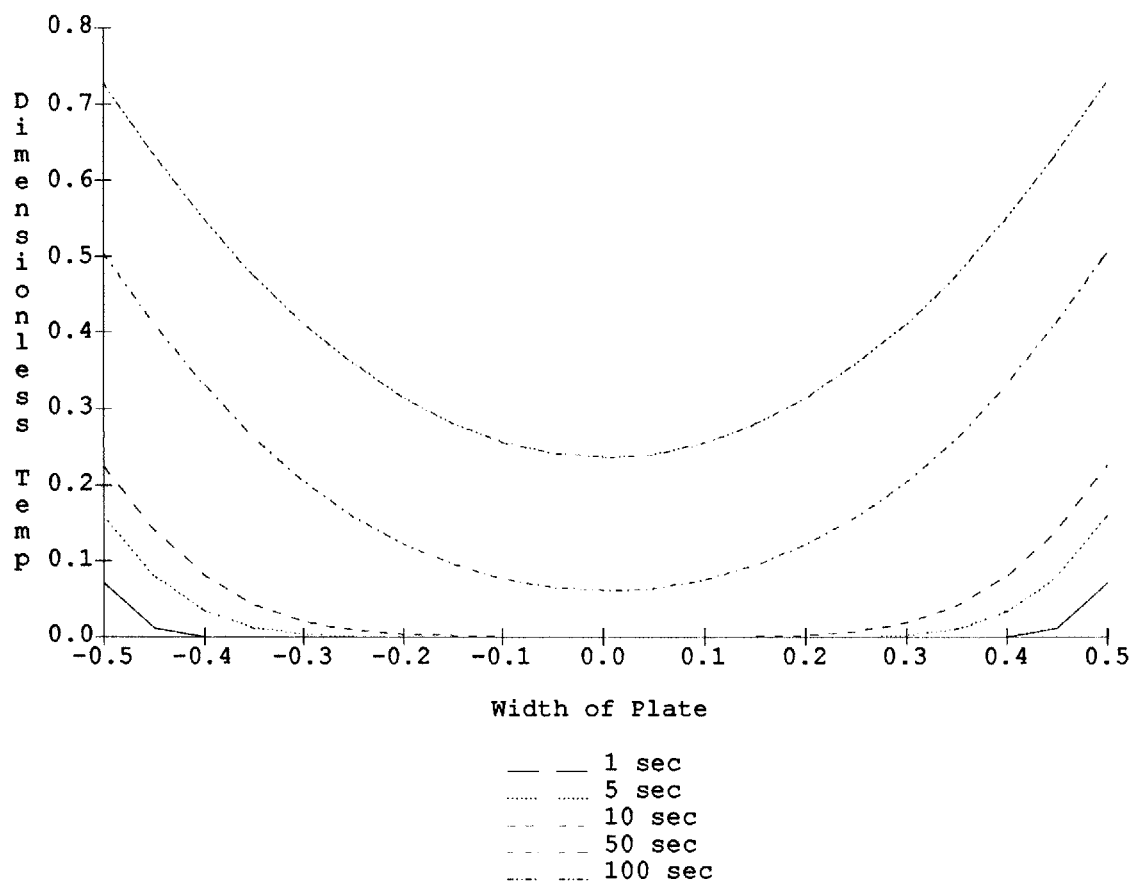

Figure 2-2: Plot of non-dimensional temperature in an infinite plate

This plot demonstrates that after a certain length of time, the temperature of the entire plate starts rising. This knowledge, when applied to the cool region in the thermoplastic sheet indicates that after a certain amount of time, the entire cool region will be gaining in temperature as the heated regions are getting warmer.

2.3 Heat Transfer in a Composite

If a band in a composite is heated, as in Figure 1-3, the heat will conduct to the cool regions through the fibers. The thermal conductivity in the 1 direction, k_1 , is approximately equal to the thermal conductivity of the fibers, k_f . The conductivity of the fibers is much greater than the conductivity of thermoplastic sheet, k_{TP} . Therefore, in the composite the heat will be conducted to the cool regions faster than in the thermoplastic sheet. This will lower the temperature gradient and, as a result, the induced anisotropy. To increase the temperature gradient between the hot and cool regions, it will be necessary to increase the separation between the heated regions.

The heat conduction in the thermoplastic sheet between the hot and cool regions is assumed to be proportional to

$$Q = k_{TP} \frac{d^2T}{dx_{TP}^2} \approx k_{TP} \frac{\Delta T}{x_{TP}}$$

where ΔT is the temperature difference and x_{TP} is the distance between the heated regions. If the same temperature difference is required in the composite, then the conduction is proportional to

$$Q = k_f \frac{d^2T}{dx_C^2} \approx k_f \frac{\Delta T}{x_C}$$

where x_C is the distance between the heated regions in the composite. It is desired to have the same amount of heat conducted in both cases above. Upon setting these equal, the relationship between x_C and x_{TP} is given by

$$\frac{x_C}{x_{TP}} = \left(\frac{k_f}{k_{TP}} \right)^{\frac{1}{2}} \equiv X \tag{2.10}$$

This factor, X , determines how much further apart the heated regions must be in the composite to get approximately the same temperature gradient as in the thermoplastic sheet.

Typical values for k_f (glass fibers: 12 W/m·°C) and k_{TP} (epoxy resin: 0.25 W/m·°C) give a multiplication factor, X , of 7. In other words, the heated regions in the composite must be seven times further apart than in the thermoplastic sheet.

Chapter 3

Experimental Methods

Many of the experiments documented in this thesis used some of the same methods and procedures. The test equipment used in all of the experiments was an Instron Tensile Testing Machine (Model 1125). The methods of heating the samples were also similar in many of the experiments.

3.1 Materials

Three materials were used in the tests described below, see Table 3-I.¹ One was an acrylate, (Plexiglass[®]), which is a low temperature, amorphous thermoplastic.² The acrylate used was in sheet form (1/16 inch thick) and was opaque black with a mirror finish. In a few of the tests the surface was sanded to remove the mirror finish. A number of other amorphous thermoplastics were tested initially (high impact polystyrene, $T_G=100^\circ\text{C}$, and polypropylene), but the acrylate was used because of its low glass transition temperature, $T_G=100^\circ\text{C}$.

Two uniaxial ATC's were also used. The first was a staple formable composite of Kevlar[®] short fibers and J2[®] polymer matrix.³ The J2 is a polyamide based, amorphous thermoplastic and is a high temperature thermoplastic.⁴ The fibers of the composite were short fibers (on the order of a few inches) made of Kevlar, a very high strength polymer fiber.

¹All polymer properties are from the Modern Plastics Encyclopedia, except as noted in the text.

²Plexiglass is a registered trademark of Rohm & Haas Co.

³Kevlar and J2 are trademarks of E. I. Du Pont de Nemours & Co.

⁴Technical name bis(para-aminocyclohexyl)methane. (Okine, 1987)

This composite came in the form of a pre-consolidated sheet (approximately 0.1 inch thick) and was a very high quality composite.

The other ATC consisted of a polypropylene matrix with glass fibers (PPGL). The polypropylene has a low melting temperature, T_M . This composite came in the form of a pre-impregnated tape (pre-preg) that was consolidated in a mold specifically designed for the task. The quality of the pre-preg was low and the resulting composite was low quality, also.

Table 3-1: Material Sample Properties

Properties of Materials Used in Experiments			
Property	Plexiglass (acrylate)	Kevlar/J2	PPGL
T_G	100 °C	~250 °C	-20°C
T_M	N/A	N/A	170 °C
V_f	0	~0.6	~0.5
Dimensions of coupons (inches)	2.0 × 7.0	1.0 × 7.0	1.5 × 6.5 1.0 × 6.5

3.2 Material Samples

The thermoplastics and ATC's used in the experiments were all originally in sheet form. The sheets were cut into "coupons" which then were heated and pulled. The coupons were cut such that there was a high aspect ratio, where aspect ratio is the length of the sample divided by the width of the sample. The aspect ratios of the coupons varied between 3.5 and 7. The reason for this was to allow any shearing to take place in the middle of the coupon while minimizing end effects.

The thicknesses of the coupons were chosen so that as the coupon was heated, the temperature would be approximately uniform through the thickness. This thickness also facilitated the quickest possible heating of the entire sample for a given heat flux. The dimensions of the coupons were all very close. Lengths varied between 5 and 7 inches.

Widths, between 1 and 2 inches. The thicknesses were on the order of 0.1 inches, which were often determined by suppliers' stocks of thermoplastic sheet.

In a few experiments involving the PPGL ATC, a core of pure polypropylene was sandwiched between two layers of composite. This was to decrease the fiber volume fraction, V_f , of the composite. All the ATC coupons were cut so that the fibers made 45° angles with the sides of the coupons. This was to permit the maximum shear to occur when the coupon was heated and stretched.

All the coupons, both ATC and Plexiglass, were painted with a 1/2 inch square grid so that any shear deformation would be noticed. This grid also made photographic reproduction of the stretched composites easier.

3.3 Heating Methods

The coupons were heated using a number of different methods, depending on which was being tested. Often combinations of heating methods were used. There were two tasks that had to be accomplished in the heating of the coupons. The first was heating the entire coupon to a point near or above the glass transition temperature or the melting temperature of the thermoplastic. The second was heating selected regions to a temperature higher than the surrounding areas. Sometimes the entire coupon was heated by heating only the selected regions and letting excess heat transfer to the cooler sections of the coupon. There were two basic heating methods.

3.3.1 Infrared heating

The most effective heating was by infrared radiation. Two types of infrared heating units were used. One was a 250 Watt heating lamp that can be found in any hardware store. The maximum attained temperature from this lamp was less than 100°C. The other was a pair of 500 Watt quartz heating panels that could reach temperatures above 1500°C.

The 250 W heating lamp was used to heat the Plexiglass and the PPGL ATC in a few experiments. The heating panels were used in the other experiments.

These heating lamps and panels were used for heating the entire coupon as well as the specific regions. Heating of the selected regions was accomplished by use of a thin metal mask. See Figure 4-1. The mask (aluminum foil or steel shim stock) had strips cut in it to let the IR radiation through. The rest of the radiation was reflected away. This mask was then attached to the coupon for the heating process.

3.3.2 Ohmic heating

In some early tests, ohmic (resistance) heating wires were used to heat specific regions. This was accomplished by attaching parallel wires to a heat resistant frame and then placing the frame against the coupon. This method was often used in conjunction with IR heating of the entire coupon. Stock 18 gauge Ni-chrome wire was used rather unsuccessfully in the first few trials. This wire proved to be too bulky and hard to work with because of its very low resistance. A good source of ohmic heating wires turned out to be a kitchen toaster. The heating wires came pre-wrapped around a heat resistant card right in the toaster. These cards were removed from the toaster and the pattern of the wires wrapped around them was modified slightly. See Figure 4-2. This proved a simple, quick way to heat narrow regions of the composite.

3.3.3 Heating times

In tests that involved the heat lamp, heating times ranged from 30 seconds to 5 minutes. In tests that used the heating panels, heating times ranged between 5 seconds and 12 seconds. In most of the tests, the sample was heated for a period of time and then the sample was pulled. In a few of the cases, the sample was heated and then pulled while the heat was continued. The reason for heating and then pulling was that the stretching of the sample behind the foil mask moved cool regions into areas exposed to IR radiation. If the

heating were to continue during stretching, then the cool regions would be heated even more, decreasing the temperature gradient further.

3.4 Testing Equipment

An Instron Tensile Testing Machine (Model 1125) was used to provide the required tensile loads on the sample coupons. The Instron is a very accurate and powerful machine, however, it was used solely for its ability to stretch a sample at a constant rate. The force required to stretch a softened (heated) coupon was very low, so grips with a relatively low gripping force (200 lbs) were used. This permitted the sample to slip out of the grips before being destroyed by the enormous forces of which the machine is capable.

The Instron is also capable of accurately measuring the forces it is applying to a sample. The force measurements were used mainly to determine if the sample had softened enough. When the force reading was small, the measurement was ignored. When the force reading was high, the heating time was increased for the next test to soften the sample more.

3.4.1 Pulling rate

The pulling rate was determined by the speed of the crosshead. The crosshead could be set to a wide range of speeds: 20.0 inches per minute to 0.001 inches per minute. The pulling rates used most often were 1.0 inch per minute and 2.0 inches per minute. In some respects this was too slow; in other respects too fast. Because the samples were very hot, compared to the ambient air temperature, it was imperative that the tests be run quickly to minimize cooling of the sample. On the other hand, increasing the pulling rate increased the strain rate, which increased the stresses in the coupon; thus the coupon would fail sooner than if there were a slow pulling rate. The pulling rate used was simply a bargained rate.

Chapter 4

Experiments On Thermoplastic Sheet

The first step in the research was to demonstrate the technique of thermally managing deformation on a simple thermoplastic. As described in Chapter 3, the material used in these tests was Plexiglass, an acrylate. Much of the initial testing was conducted to find a suitable thermoplastic and suitable heating methods.

4.1 The Use of Acrylate

It was determined that an amorphous thermoplastic with a low glass transition temperature would perform best. An amorphous thermoplastic will act as a glass under the T_G , but above the T_G it acts rubbery. As the temperature is increased, the plastic gets more rubbery. It is this transition between glassy and rubbery that makes the amorphous thermoplastics a good choice for these experiments. A plastic with a low T_G would permit easy heating in the laboratory.

A number of thermoplastics were considered, but most had T_G 's that were too high. Others were too tough, even in the rubbery region. Acrylate was chosen because it is amorphous, has a very low T_G (100 °C), and comes in a wide variety of forms. The form used in the experiments was black 1/16 inch thick sheet. The black color was chosen to aid the infrared heaters. The black dye decreased the transmission of the IR radiation through the sample, increasing the absorption. A few of the samples were sanded to remove their mirror finish. This was done to decrease the reflectance of the coupon so that absorption would be increased. It was later found that the mirror finish did not affect the absorption greatly.

4.2 Experimental Procedure

In these experiments, the black Plexiglass sheet (1/16 in thick) was cut into coupons 2 inches by 7 inches. Approximately half of these coupons were cut from Plexiglass sheet that had been sanded to remove the mirror finish. These samples were then painted with a white half inch grid. After being clamped into the Instron, the crosshead rate was set and the heating unit(s) were moved into place. The heating process was monitored and the Instron was activated immediately upon completion of the heating. The crosshead was stopped before or just after the sample began to fail. It was then allowed to cool in the machine in tension so that the full deformation would be preserved.

4.2.1 Heating with IR lamp and foil mask

The 250 W heating lamp was used in these experiments. A foil mask was attached to the composite so that only the exposed regions would be heated. See Figure 4-1. The foil mask had slits cut in it 0.175 inches wide, spaced 0.325 inches apart. The slits were oriented at an angle of 45° when the mask was placed over the composite. A second mask was made with 30° slits. The foil mask was attached to the coupon simply by folding the edges of the mask around to the back of the coupon. It was held in place by the friction between the mask and the sample.

Only one lamp was used in these tests. It was mounted directly facing the Plexiglass coupon at a distance of 3 inches. The heating times ranged between 30 and 75 seconds. The pulling rates ranged between 0.5 inches per minute and 5 inches per minute.

4.2.2 Heating with ohmic heating wires

The second method of heating the specified bands of the coupon was using an ohmic heating unit (or resistance heating unit). The heating unit was a heat resistant card wrapped with heating wires. Two units were made, the first with the wires at 20°, spaced 0.45 cm apart. The second was made with the wires at 30°, spaced 0.9 cm apart. See figure 4-2.

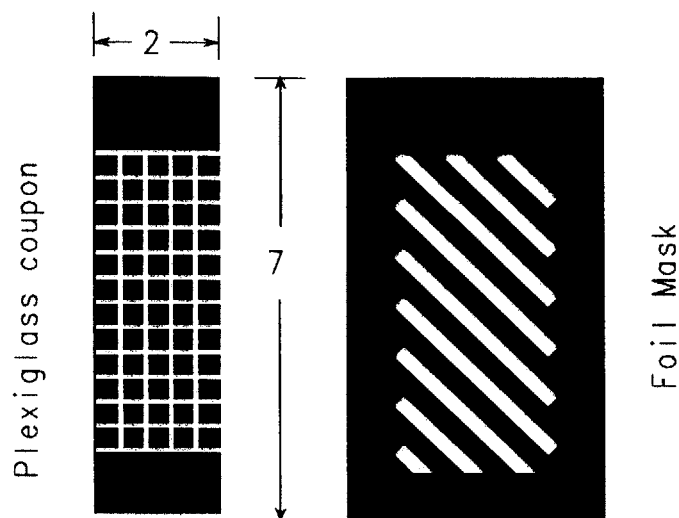

Figure 4-1: Plexiglass coupon with grid and foil mask

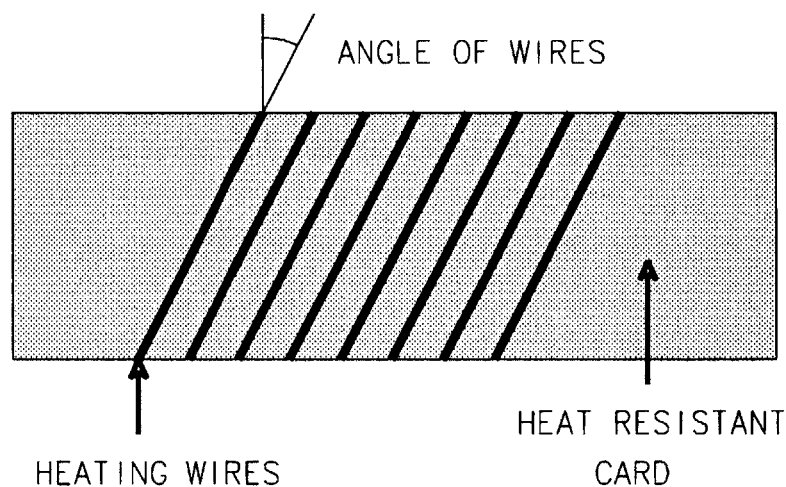

Figure 4-2: Ohmic heating device (from toaster)

This wire-wrapped card was then pressed against the Plexiglass coupon and held in place by rubber bands. A 120V AC wall current was then connected to the wires, which were immediately brought up to a high enough temperature for them to glow red. The current was left on for periods ranging between 6 and 9 seconds. It was hoped that this would heat the desired regions while also conducting some heat to the cooler regions.

A number of tests were also conducted using both the IR heating lamp and the ohmic heating units. In these tests the coupon was heated to a point near the T_G with the IR heat-

ing lamp (approx. 40 sec.) and then it was "zapped" with the ohmic heating device for a few seconds to heat the desired regions above the T_G .

4.3 Results of Tests on Thermoplastic Sheet

Thermal anisotropy was successfully induced in the Plexiglass sheet using both methods of heating. Heating with the IR lamp and the foil mask produced the most dramatic results. Heating with the ohmic heating unit alone was not effective; however, heating with both the ohmic heating unit and the IR lamp produced good results.

4.3.1 Heating with IR lamp and foil mask

The experiments conducted with the heating lamp alone were found to work best when the sample was heated for 45 seconds. Heating times above 45 seconds brought the cool regions to a temperature too close to the T_G and the whole coupon was soft. Heating times below 45 seconds did not bring the heated regions up to the T_G and the whole coupon was too brittle. Brittle coupons broke easily in the Instron, while soft coupons showed no shear deformation.

The optimum pulling rate in these experiments was 2.0 inches per minute. Speeds faster than 2.0 inches per minute caused the coupon to tear easily due to the high strain rate. Speeds lower than this allowed the temperatures in the coupon to equilibrate, reducing the temperature gradient. The lower speeds also permitted the coupon to cool due to natural convection to the surrounding ambient room air; although, speeds of 1.0 inch per minute did produce acceptable results in a few tests.

Using a heating time of 45 seconds and a pulling rate of 2.0 inches per minute, extensions of up to 15% (of the 7.0 inch coupon) were achieved. Many of the sample coupons started to rip before the Instron crosshead could be stopped. Despite the slight rips and tears, noticeable, discrete shear was observed. See Fig. 4-3. This shear deformation was

highly incremental, due to the hard and soft properties of the hot and cool regions of the coupon. The hot regions were the sites of heaviest deformation; the cool regions were deformed very little. This is noticeable in Fig. 4-3 as a "staircase" effect. This phenomenon also produced an interesting necking in the heated bands. This necking gave the pulled coupon a thin-thick quality that mapped to the heated and cool regions.

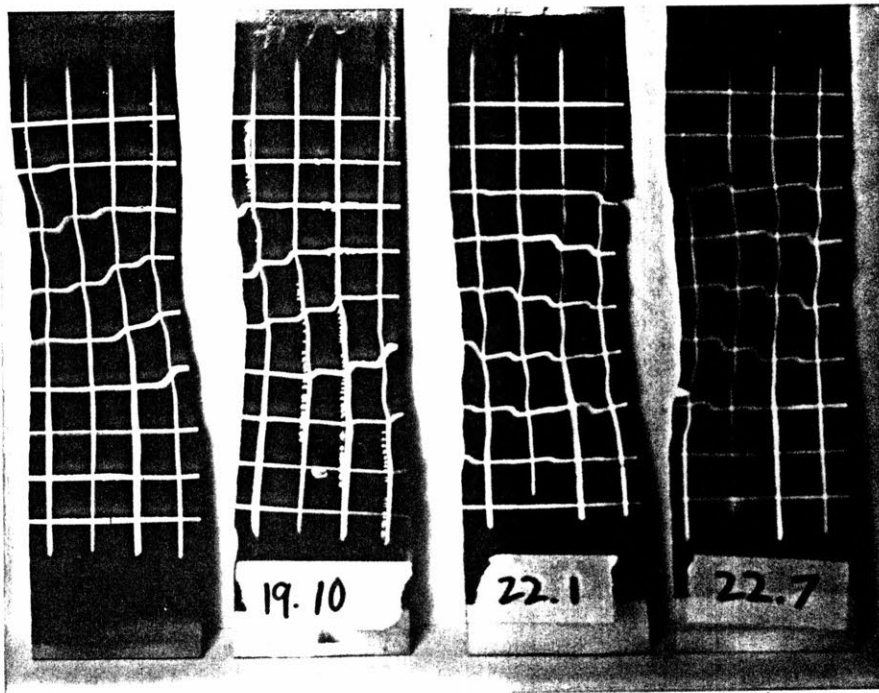

Figure 4-3: Pulled plexiglass coupons, heated with IR lamp and foil mask

4.3.2 Heating with ohmic heating wires

A few samples were heated with the ohmic heating unit alone. In these experiments the regions to be heated were often melted or burned away by the heating wires due to long heating times. In addition to the destruction of the heated regions, the cool regions were left much too cool. It was determined that if the entire coupon were to be heated to a temperature near the T_G with the IR lamp, then the ohmic heating unit could be used to heat regions without burning or melting the acrylate.

When this combination heating method was applied to the coupons, the results were very favorable. The optimum IR lamp heating time was 40 to 45 seconds. The sample was then heated for 3 or 4 seconds with the ohmic heating unit. The pulling rate was 2.0 inches per minute in all of these experiments.

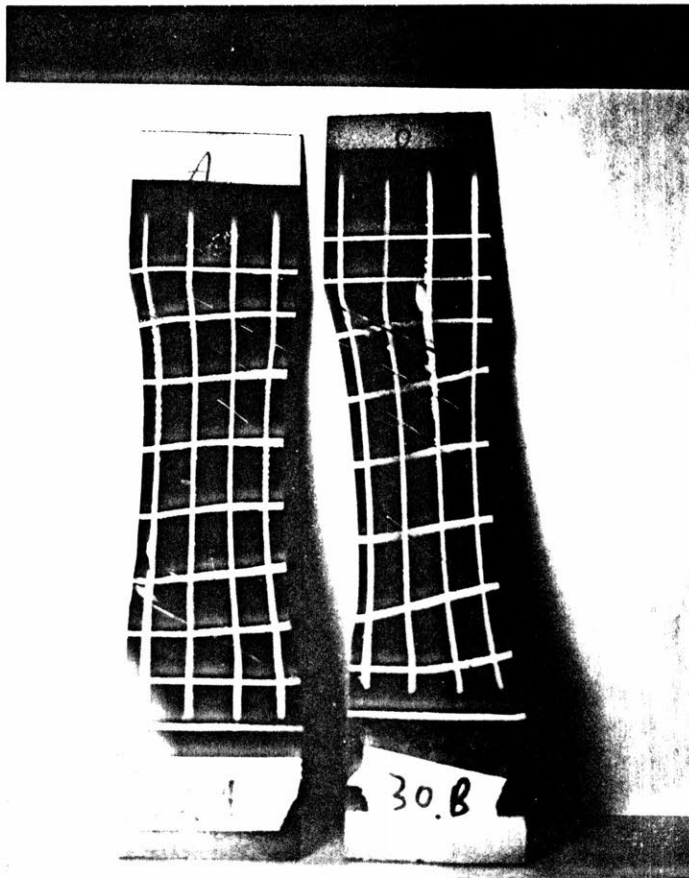

Figure 4-4: Pulled Plexiglass coupons, heated with IR lamp and ohmic unit

The results were good. See Figure 4-4 The shear was less dramatic than in the experiments that used only the IR lamp with the mask. However, the shear was less incremental and more continuous across the sample. This was due to the fact that the entire coupon was heated to a point near the T_G , and then regions were heated to a point far above the

T_G . This produced close to the same temperature gradient as in the previous experiments, but this time the entire coupon could deform. As a result of this, the coupons attained extensions of up to 30%, double the extension of samples heated with the IR lamp and foil mask. There was no necking and no staircase effect in these pulled samples.

Figure 4-5 shows three coupons that were heated and stretched. The coupon on the left was heated uniformly and deformed. It demonstrates the uniform deformation that is expected. The coupon on the right has been heated with only the ohmic heating unit. It shows some discrete shear. The middle coupon was heated with both the IR lamp and the ohmic heating unit. This sample shows much more uniform shear deformation. The discrete bands of deformation present in the other coupon have been smoothed over by heating the entire coupon.

4.4 Interpretation of Results

The theory of thermally controlling the deformation of a thermoplastic sheet by selective heating was demonstrated. Of the three heating methods tested, two showed promise. See Table 4-I. The most pronounced shear deformation was produced by heating only the selected regions of the sample with the IR lamp, although greater extensions were produced using both the IR lamp and the ohmic heating device.

The best results can be obtained by heating the entire sample to a point that is near the T_G and then heating regions to a point well above the T_G . The results of the tests that used both IR and ohmic heating could have been improved if the heated regions had been hotter. This would have increased the temperature gradient causing a more pronounced shear, as in the tests conducted with only the IR lamp.

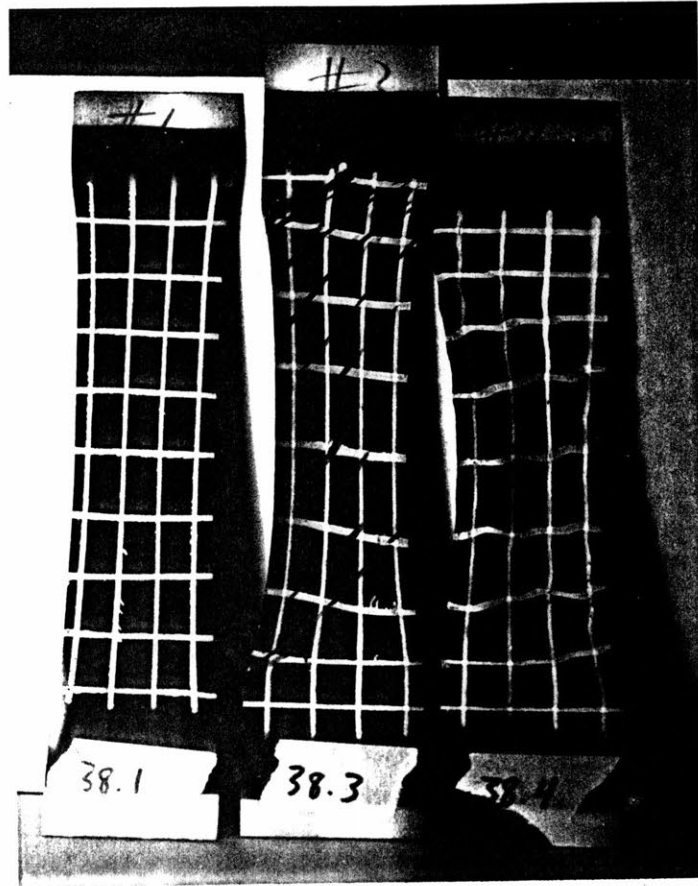

Figure 4-5: Comparison of heating methods on Plexiglass coupons

Table 4-I: Results of tests on Plexiglass samples

Heating Method	Max. Extension	Noticeable Shear Deformation	Results
IR/Mask	15%	yes	good
Ohmic heating device	10%	no	poor
IR/ohmic	30%	yes	fair

Chapter 5

Demonstration of Shear in an ATC

In theory, a uniaxial composite will shear when it is stretched in a direction that is not a principle direction of the composite (see Chapter 2). In practice, most composites tear long before any appreciable deformation occurs. The experiments documented in this section were conducted to find an ATC that would deform appreciably and the conditions under which this would occur.

The first experiments were done on a polypropylene/glass (PPGL) ATC using the 250 W heating lamp. This did not produce good results due to a number of reasons, so a second ATC was investigated. Kevlar/J2 composite was tested, requiring the 500 W heating panels. These experiments had their own problems. The final experiments were conducted on PPGL with the 500 W heating panels and information learned in the Kevlar/J2 experiments.

5.1 The Use of Polypropylene/Glass ATC

The PPGL ATC was originally chosen for the experiments for two reasons. First, polypropylene is a relatively low temperature thermoplastic ($T_M=170^\circ\text{C}$); not as low as acrylate, however. Second, there was an abundant supply of PPGL pre-preg in the laboratory. A mold was designed to consolidate the pre-preg into a composite sheet. See Appendix B.

The PPGL pre-preg tape was very poor quality with imperfect wetting of the fibers and miss-aligned fibers. The imperfect wetting caused fibers to bunch up with no polymer to hold them together. When the pre-preg tape was consolidated, the fibers were still not wetted in many places. This produced bunching of the fibers in the final composite. There were also miss-aligned fibers in the final composite, due to flow of the polymer in the mold.

The miss-aligned fibers did not affect the experiments significantly; however, the bunched fibers did.

The bunched fibers in the ATC caused the coupon to rip easily. Normally, the composite's weakness is between the fibers, where there is only polymer matrix to hold the composite together. When the fibers are bunched together, there is no polymer matrix to hold the composite together, and there is a greater chance of ripping in these locations. In these cases the tangled, miss-aligned fibers actually helped to keep the composite from ripping

5.1.1 Experimental Procedure

The consolidated composite was cut into samples 1.5 inches by 6.5 inches and a black half inch grid was painted on one side. Some samples were also cut 1 inch by 6.5 inches. In some cases, the back of the coupon was painted flat black to increase IR radiation absorption. The 250 W heating lamp was used to heat the entire composite sample. No selective heating was attempted. The coupon was clamped in the Instron and the lamp was placed 3 inches from the coupon. Heating times ranged from 80 to 220 seconds, and the pulling rates from 0.5 inches per minute to 5.0 inches per minute.

5.1.2 Results

It was found that the imperfections in the PPGL samples caused them to fail quickly. Some experiments were further complicated by uneven heating by the lamp. The results were not good: localized deformations and premature tearing. See Figure 5-1. Extensions of the 5 inch exposed section of the samples were approximately 5-10%. Unfortunately, this deformation was often highly localized with some sections extending over 50%.

It was found that incorporating a dwell time between heating and pulling equalized the uneven heating. The dwell time was approximately 20 seconds. However, this dwell

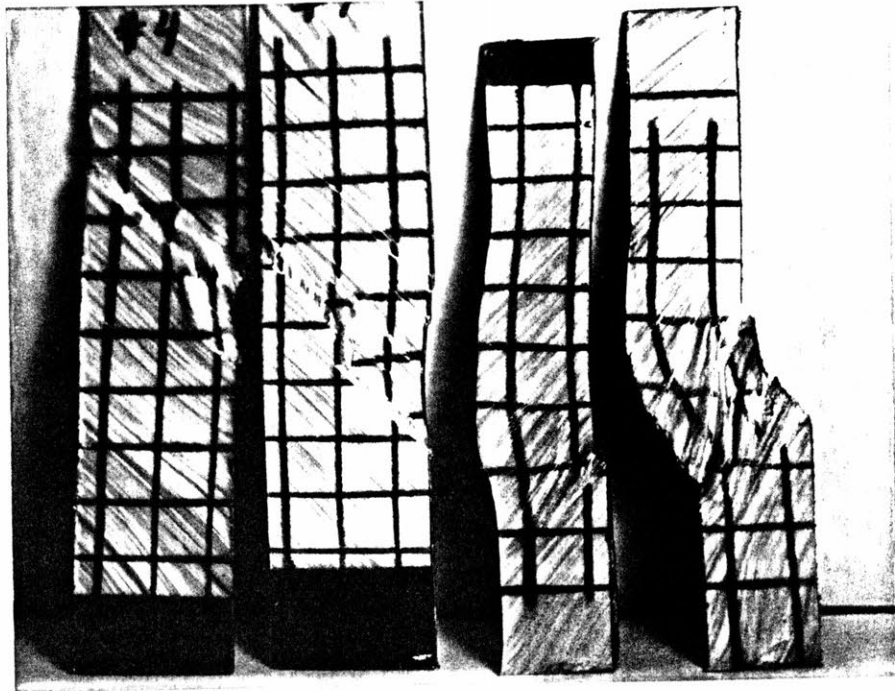

Figure 5-1: Pulled polypropylene/glass ATC samples

reduced the temperature of the entire sample and did not greatly affect the extension. The deformation was more uniform, but there was less of it.

In addition to uneven heating of the sample coupons, they also ripped easily. The rips often occurred at a section where there was very little polypropylene. These sections were the locations of bunches of fibers that were not wetted completely when the composite was consolidated. Rips also occurred in regions where there was a high density of fibers, regardless of how well the fibers were wetted. This suggested that there was not enough matrix to hold the fibers together.

5.2 Use of Kevlar/J2 ATC

A uniaxial composite of short Kevlar fibers in a J2 matrix (a polyamide based polymer) was used for a number of experiments. This composite was chosen for two reasons. First, the composite was a very high quality composite; it came in the form of a pre-consolidated sheet. There was very little fiber miss-alignment. Second, the short Kevlar fibers could slide past one another slightly when pulled in the direction of the fibers. (Okine, 1987) It was hoped that this ability would slightly decrease the stresses perpendicular to the fibers. It was these stresses that caused the composite to shear and tear.

The major disadvantage of using the Kevlar/J2 composite was that the J2 matrix was a medium-high temperature thermoplastic (recommended processing temperature: 315°C). (Okine, 1987) This is why the 500 W heating panels were acquired.

5.2.1 Experimental procedure

The Kevlar/J2 was cut into strips 1 inch wide by 7 inches long with the fibers at an angle of 45° to the edges of the coupon. A black half inch grid was painted on the back of the coupon. The coupon was placed in the grips of the Instron and heated for 7 to 12 seconds by the two 500 Watt heating panels.

A frame was constructed to hold the two heating panels facing each other, spaced approximately one inch apart. The heating panels were controlled by a timing unit. The timing unit was a cycling on-off switch with a cycle time of 15 seconds. The unit could be set so that the panels would receive a current for a percentage of the 15 second cycle time. The heating panels had enough thermal mass for the heat produced to appear constant, even though the supply current was intermittent. The percentage of time that the current was being supplied to the heaters was proportional to the heat produced by the heaters. This way the temperature of the heating panels could be controlled.

The control unit was set at percentages from 50% to 90% to vary the temperature of the heating panels. The heating times were also varied from 7 to 15 seconds. The crosshead speed was set at rates between 0.5 and 5 inches per minute.

5.2.2 Results

Most of the Kevlar/J2 samples deformed as expected and demonstrated the shear deformation. However, the samples all ripped or deconsolidated before any appreciable extension could occur, even more so than the best PPGL ATC samples tested. See Figure 5-2.



Figure 5-2: Pulled Kevlar/J2 samples

The best results were obtained when the control timer was set below 75%. Percentages above this resulted in the heaters being too hot and the samples burning on the surface. The optimum heating time at 75% was 10 seconds. Times longer than 10 seconds resulted in burnt samples. Times less than 10 seconds did not allow the sample to soften enough. As in the previous tests, the best pulling rates were either 1 or 2 inches per minute.

The maximum extension in these tests was 13%, assuming that only 5 inches of the 7.5 inch sample was heated and deformed. The deformations in these experiments were more uniform than in the tests conducted on PPGL. The 500 W heating panels quickly and evenly heated the samples.

Despite the high quality of the Kevlar/J2 ATC, the samples often ripped. It is suspected that these samples ripped for the same reason that the PPGL samples ripped; there was not enough polymer matrix to hold the fibers together. Because the Kevlar/J2 composite had a higher fiber volume fraction than the PPGL, there was even less matrix.

5.3 Use of Polypropylene/Glass ATC with Polypropylene Core

A number of tests were run using samples of PPGL that had a core of pure polypropylene. One of the reasons that the samples in the previous experiments ripped was that there was not enough polymer matrix to hold the fibers together. Increasing the amount of polymer matrix in the composite could increase the extension of the sample when it is pulled. This would result in more pronounced shear deformation.

Because the composite must be consolidated from a pre-preg tape, it would be difficult to increase the matrix volume fraction, V_m , uniformly. The V_m was increased by placing a core of pure polypropylene between two layers of PPGL composite. This three layer composite was then consolidated in a mold and cut into coupons 1.0 inches by 6.5 inches. A black half inch square grid was painted on the coupons.

Another problem experienced with the PPGL composites tested in section 5.1 was the uneven heating produced by the 250 W heat lamp. The 500 W heating panels were used in this set of tests to provide a more reliable heat source. These heating panels could quickly heat the composite to a point above the melting temperature and leave the core cool, adding strength to the composite.

5.3.1 Experimental procedure

Composites with different core thicknesses were consolidated. All had the same amount of PPGL composite, which was approximately the same amount of PPGL used in the experiments described in Section 5.1. Two core sizes were used: twice the thickness of PPGL (referred to as *double*), and a thickness equal to the PPGL thickness (referred to as *single*). Coupons with no polypropylene core were also tested again. See Figure 5-3.

These samples were heated and pulled in the same way as the Kevlar/J2 samples. Heating times ranged from 7 to 15 seconds and pulling rates were either 1 or 2 inches per minute.

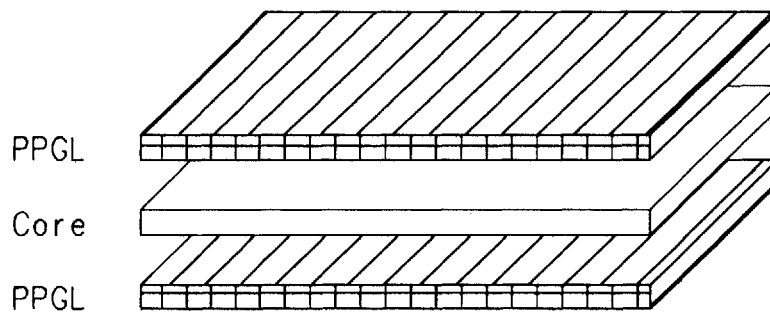

Figure 5-3: PPGL samples with cores of polypropylene

5.3.2 Results

As expected, the best results were obtained from a sample that had a core of polypropylene. Extensions of approximately 20-25% were obtained from samples with a single polypropylene core. The samples with a double core were too thick to heat com-

pletely; the core stayed too cool and hard. The greatest extension of a coupon with no core was 14% which is twice the extensions observed in previous tests with the 250 W heating lamp.

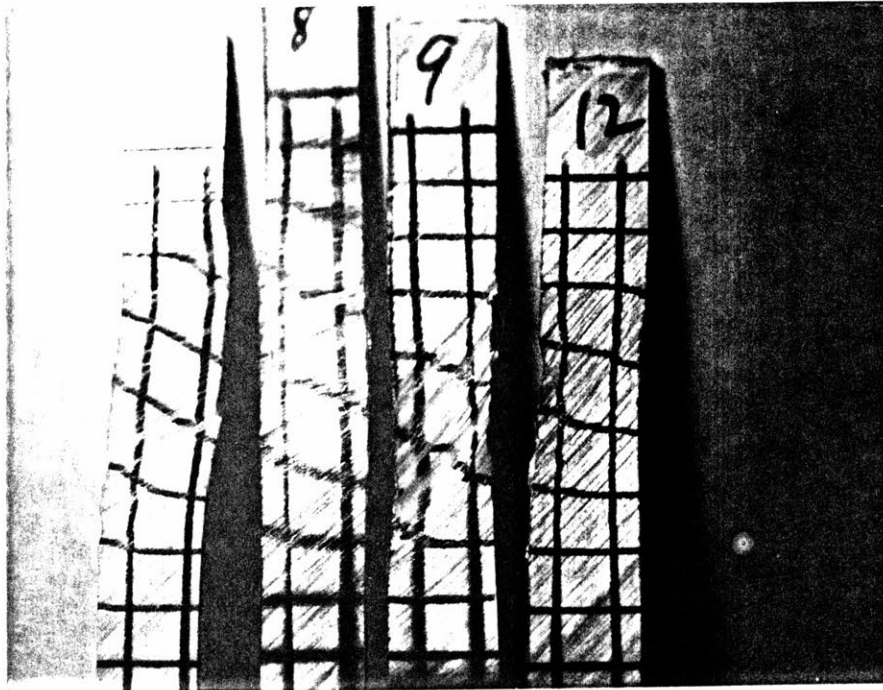

Figure 5-4: Pulled samples of PPGL ATC with polypropylene core

Figure 5-4 shows some samples with polypropylene cores that were heated with the 500 W heating panels. Compare these with the samples shown in Figure 5-1. The samples with the cores that were heated with the heating panels show much more uniform deformation. There is also a pronounced shear deformation. The sample on the left had no core of polypropylene. The middle two coupons had a single core, and the rightmost coupon had a double core of polypropylene. The sample with no core surprisingly showed a large extension. This coupon may have deformed more than the coupons in earlier tests because it was pulled at a higher temperature and was heated more evenly.

Despite the fact that the deformation was more extensive, the results were not much better than before. Due to the poor quality of the PPGL composite, there were sections in the pulled samples with no fibers and sections with bunches of fibers. Only the core of polypropylene held the samples together, allowing the fibers to separate.

5.4 Interpretation of Results

Every test conducted demonstrated the anisotropic shear deformation in the composite; however, not every sample demonstrated the extensive shear deformation which was being sought. See Table 5-I for a summary of the results. It became apparent that an ATC must have a high V_m for there to be appreciable deformation when it is heated and pulled. Increasing the amount of polymer matrix gave the composite more integrity; there was more material to hold the fibers together, permitting it to deform more extensively before ripping. A side effect of an increased the V_m was a decreased V_f (by definition, $V_m + V_f = 1$). A decrease in the amount of fibers will decrease (but not eliminate) the magnitude of the anisotropic behavior.

Table 5-I: Results of experiments to demonstrate shear in ATC samples

Type of ATC	Heating Method	Max. Extension	Noticeable Shear Deformation	Results
PPGL	250 W lamp	14%	yes	fair
Kevlar/J2	500 W panels	13%	yes	poor
PPGL with core	500 W panels	25%	yes	good

Chapter 6

Controlling Anisotropic Deformation in an ATC

The idea of controlling or managing the deformation of a uniaxial composite that has been heated and stretched can only be applied to composites that demonstrate a certain amount of deformation. If there is little or no deformation, then the idea is moot, whether there is anisotropy present or not. Many composites fail before any appreciable deformation occurs. As shown in Chapter 5, there are a number of reasons why composites fail before deforming extensively.

The main reason that the composites failed without deforming appreciably is because there was not enough polymer matrix to hold the fibers together; they lacked integrity. The V_m was artificially increased by adding a core of pure polypropylene to the composite. This increased the extent of the deformation enough to demonstrate the anisotropic behavior in the composite. However, this still produced poor results (see Section 5.3.1).

There are a number of reasons why selectively heating regions of an ATC sample may not control the deformation as effectively as the method did in a simple thermoplastic sample. First, the high quality composites that were available did not have a high matrix volume fraction. The composites that were available were too prone to tearing.

Second, to counteract the natural anisotropy of the uniaxial composite, it would be necessary to heat bands of the composite that were rotated 90° from the direction of the fibers. This would cause the fibers to be oriented in a direction parallel to the direction of heat conduction between the heated bands and the cool bands. Most fibers, especially carbon and graphite, have high thermal conductivities compared to the thermal conductivity of the matrix polymer. The Kevlar and glass fibers are also more conductive than the matrix polymers. This increased conductivity in the direction of heat transfer causes the cool

regions to be heated even more quickly than in the simple thermoplastic samples. This decreases the temperature gradient in the sample and produces a less dramatic induced anisotropy. (See Section 2.3.)

Third, to counteract the high heat conduction from the heated regions to the cool regions due to the orientation of the fibers, it would be necessary to space the heated regions relatively far apart. This would increase the temperature gradient, but would require a much larger coupon to accommodate the larger cool regions.

And fourth, as shown in Figure 1-3 on Page 11, the fibers of the ATC will be deformed into "stair cases" after the sample is selectively heated and stretched. If the induced anisotropy is very pronounced, then the stiffness of the fibers must be taken into account.

For these reasons, it was decided that an attempt to demonstrate the theory on an ATC sample would be premature.

Chapter 7

Suggestions for Further Research and Conclusions

7.1 Further Research

There are obviously a number of problems that will have to be overcome before extensive research can be done to prove this method of controlling deformation. The main problem that must be overcome is that of the composites tearing before any appreciable deformation can occur. There are two ways the research could follow to approach this problem.

First, rather than deforming the composites in tension, use compression. This will eliminate the inherent instabilities that cause a composite to tear when it is pulled off-axis. This may introduce instabilities that are inherent to compression, however. Second, explore the availability of high quality, high matrix content composites with relatively low temperature resins. If composites of this type are available, explore the use of these composites in the tests.

Further research should be conducted in a number of areas. First, thermal management of deformation in a thermoplastic sheet should be explored and researched quantitatively. The research for this thesis showed qualitatively that a thermal anisotropy can be induced in a thermoplastic sheet, but more work is required to completely understand the process. Another area that should be researched is the conduction of heat in the composite. A study of the effect of the fibers on the heat conduction between hot and cold regions would certainly prove useful.

7.2 Conclusion

Thermal management of deformation in an ATC is an enticing concept. The fact that an anisotropy can be induced in a material by localized heating has been demonstrated on a thermoplastic sheet. However, demonstrating this technique on an ATC will prove to be much more of a challenge. The problems of composites that tear easily and heat conduction that is complicated by fiber orientation make the application of this process to ATC's much more complicated than it is with a thermoplastic sheet. Thermally managing the deformation by inducing an anisotropy in an ATC may be possible; the results obtained so far are promising, but in no way do they prove that the technique will work. It is only through further research that this technique can be proven.

Appendix A

Heat Conduction in an Infinite Plate, Solution

The following is the FORTRAN code used to solve Equation (2.9) which was the solution to an infinite plate subject to a constant and equal flux on each side.

```
REAL ALPHA, TIME, X, CAPX, L, FO, GROUP, DTEMP
REAL PI, SUMM1, SUMM2, PART1, LAMBDA, PART2, PART3
REAL COND, FLUX

INTEGER I, N, STEPS, J

WRITE(6,*) 'ENTER TIME SPAN IN SECONDS'
READ(5,*) TIME

C INITIAL VALUES

N = 20
STEPS = 20
ALPHA = 0.001
L = 0.5
FO = (ALPHA*TIME)/(L**2)
PI = 3.14159

GROUP = 0.0
C GROUP IS THE NON DIMENSIONAL TEMPERATURE GROUP

C SOLVE BY LOOPING

DO 20 I = 0, STEPS

X = (-1.0)*L + I * (2.0 * L/STEPS)
CAPX = X/L
SUMM2 = 0.0
DO 10 J = 1, N

LAMBDA = J * PI
PART1 = COS(LAMBDA * CAPX)
PART2 = EXP((-1.0) * (LAMBDA**2) * FO)
PART3 = ((-1.0)**J) / (LAMBDA**2)
SUMM1 = SUMM2 + (PART1 * PART2 * PART3)
SUMM2 = SUMM1
```

10 CONTINUE

 GROUP = FO + (CAPX**2)/2.0 - 1.0/6.0 - 2*SUMM1
 WRITE (6,*) X, ', ', GROUP

20 CONTINUE

 STOP
 END

Appendix B

Mold for Consolidating Polypropylene/Glass Pre-Preg

The polypropylene/glass composite came in the form of a pre-preg tape, 2 inches wide by 12 inches long, with the fibers oriented in the long direction. The tape was approximately 0.05 inches thick. This tape was consolidated into a 6 inch by 6.5 inch composite in a mold specifically designed and built for the purpose.

The tape was cut into sections and placed in the mold oriented at 45° with respect to the walls of the mold. The tape was placed in the mold with pieces overlapping, making approximately 2 and 1/2 layers of pre-preg. The mold was then placed in a hot press. The temperature of the mold in the press was raised to approximately 180°C at a pressure of approximately 170 psi. The mold was left at this temperature and pressure for 30-45 minutes and then cooled, still under the high pressure.

The composite was then removed from the mold and cut into samples. There was a fair amount of fiber miss-alignment due to resin flow in the mold, but this did not significantly affect the experiments.

References

- Maurice A. Biot. *Mechanics of Incremental Deformations*. New York: John Wiley & Sons, Inc., 1965.
- Timothy G. Gutwoski. A Brief Introduction to Composites. March 1983.
- Robert M. Jones. *Mechanics of Composite Materials*. Washington, D.C.: Scripta Book Company, 1975.
- Modern Plastics Encyclopedia, 1986-1987*. New York: McGraw-Hill, Inc., 1986.
- R. K. Okine, D. H. Edison, and N. K. Little. Properties and Formability of a Novel Advanced Thermoplastic Composite Sheet Product. In *32nd International SAMPE Symposium*. SAMPE, 1987.
- James H. VanSant. *Conduction Heat Transfer Solutions* (Tech. Rep. UCRL-52863 Rev. 1). Livermore, CA: Lawrence Livermore National Laboratory, University of California, August 1983.