

OPTIMUM DESIGN OF A STATIC
SINGLE-PHASE FREQUENCY TRIPLER

by

Robert William Reichard

Submitted in Partial Fulfillment of the
Requirements for the Degree of
Master of Science
at the
Massachusetts Institute of Technology
(1955)

Signature Redacted

Signature of Author

Department of Electrical Engineering, 23 May, 1955

Signature Redacted

Certified by

Thesis Supervisor

Signature Redacted

Accepted by

Chairman, Departmental Committee on Graduate Students

OPTIMUM DESIGN OF A STATIC SINGLE-PHASE
FREQUENCY TRIPLER

by

Robert William Reichard

Submitted to the Department of Electrical
Engineering on 23 May 1955 in partial fulfill-
ment of the requirements for the degree of
Master of Science.

ABSTRACT

The purpose of frequency multipliers in in-
creasing the performance and adding to the appli-
cability of magnetic amplifiers in many marginal
applications is defined. A type of static multi-
plier is described, the dependability of which is
compatible with that of contemporary magnetic
amplifiers.

The operation of these triplers with various
degrees of optimization is discussed, along with
the reasons why these difference degrees may be
desirable in various applications. A design
procedure is given such that triplers of optimum
power efficiency and good waveform quality can
readily be assembled.

A method of analysis of the single-phase
tripler is formulated which is capable of solution
on a standard Reeves Electronic Analogue Computer.
Examples of computer solutions for representative
partially-completed tripler circuits are presented,
and a brief comparison is made with the actual
results obtained experimentally.

Thesis Supervisor: George C. Newton, Jr.
Title: Associate Professor of Electrical Engineering

Voil (e. e.) Sept 27 1955

TABLE OF CONTENTS

- 1.1 The need for frequency multiplication.
- 1.2 The saturable reactor frequency multiplier.
- 1.3 The need for an analysis or a set of descriptive parametric curves.
- 1.4 Brief description of the approach to analysis and a suggested approach to assembling triplers.
- 1.5 Results of the attempted analyses.
- 1.6 Conclusions.
- 2.1 Background history of static frequency multipliers.
- 3.1 Basic operation of a single-phase tripler.
- 3.2 Practical considerations in assembling single-phase triplers.
- 4.1 The computer analysis of tripler circuits.
- 4.2 Representative results obtained on the computer.
- 4.3 A few experimental results and their comparison to the results of computer analysis.
- 5.1 Appendix.
- 6.1 Bibliography.

1.1 THE NEED FOR FREQUENCY MULTIPLICATION

Inherent among the characteristics of most magnetic amplifiers in current usage is a delay, or deadtime, which characteristic very frequently becomes a major limiting factor in the operation of high-performance systems which encompass these amplifiers.¹ The deadtime can, through careful design or choice of circuit, be held close to a theoretical minimum, which figure is customarily expressible as a small number of half-periods of the power-supply frequency. A deadtime is particularly objectionable in a 60 cps magnetic amplifier where, for example, a conventional half-wave bridge magnetic amplifier has a deadtime of about one period of the supply frequency. In the terminology of servo techniques, then, this amplifier will contribute a phase factor, due to the deadtime alone, of $e^{-0.0167s}$ to the effective transfer function of this amplifier, and a simple calculation shows that this factor alone will contribute 45 degrees of phase lag to the system at a frequency of about 7.5 cps, such that a very definite restriction is placed upon the ultimate system performance.

¹ Superscripts refer to similarly numbered entries in the Bibliography.

There are numerous methods for reducing this delay; for example, it is possible to assemble a gating circuit in the input or control windings of each stage such that an output can be obtained during the same period in which its respective control is applied.² There have been other methods described in the literature³, all of which require some auxiliary components. The obvious method is merely to raise the frequency of the power supplied to the magnetic amplifier. Since one of the exemplary features of magnetic amplifiers is their long life with a minimum of maintenance, it would be desirable to create a power supply having these same features of ruggedness and durability.

1.2 THE SATURABLE-REACTOR FREQUENCY MULTIPLIER

Such a device is the saturable-reactor frequency multiplier. This device, as currently known, can operate from either a polyphase or a single-phase source, and its components consist only of single-winding saturable reactors plus a number of linear inductors and capacitors which is a function of the quality of the waveform desired in the output. It has been demonstrated⁴ that a magnetic amplifier in an instrument servo system can be operated from a three-phase frequency tripler which consists only of three saturable reactors and a step-up transformer.

The supplementary componentry thus represented is comparatively small and inexpensive and contributes measurably to the performance of the system.

1.3 THE NEED FOR AN ANALYSIS OR A SET OF DESCRIPTIVE PARAMETRIC CURVES

It has been demonstrated²⁰ that static frequency multipliers of the saturable reactor type can be assembled into compact, reliable systems for the primary purpose of increasing the bandwidth of magnetic amplifiers, with the secondary result in some applications that a type of annoying drift can be greatly reduced.¹⁶ These multipliers have of necessity been designed from purely empirical considerations, in particular those which operate from a single-phase power source, since there has apparently been no successful attempt at an analysis that could be called comprehensive.

With proper care, single-phase triplers can be built to have widely varying characteristics. In some applications, for instance in a case where the output supplies another cascaded tripler, the output waveform may not be critical, while in a tripler used directly to power a magnetic amplifier, the presence of a component of fundamental frequency in the output may violate one of the secondary principles¹⁶ for which the

tripler was intended. In some applications, the power efficiency and weight may not be important, while in a tripler intended to accompany a magnetic amplifier in an aircraft application, both the weight and efficiency factors might be quite important.

Since there is a conflict between size, weight, number of components, and the parameters of efficiency, waveform quality, and voltage regulation, it is apparent that there should be some better basis of making an engineering compromise than the arbitrary selections which now occur.

1.4 BRIEF DESCRIPTION OF THE APPROACH TO ANALYSIS

The stated intent of this thesis was to formulate data, either in equation form or in a set of parametric curves, by means of which a single-phase tripler could be straightforwardly designed for specific applications. The particular circuit chosen as representative was a type (Fig. 1.41) utilizing a transformer-connected linear inductor and a single-winding saturable reactor for the switching section, and various systems of linear inductors and capacitors as filtering elements, of which the configuration in Figure 1.41 is typical. This circuit, by virtue of the transformer connection, has two equivalent circuits in time, similar

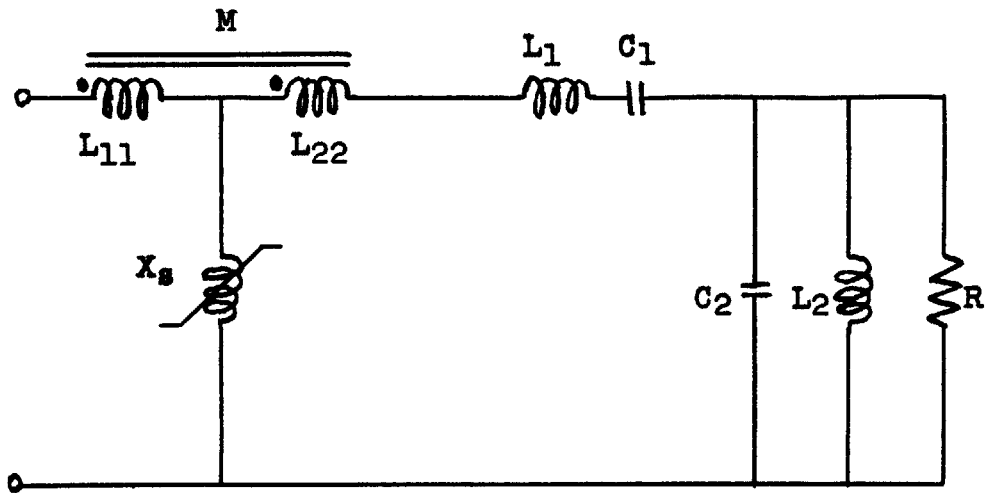

Figure 1.41 A FREQUENCY TRIPLER OF THE TRANSFORMER TYPE

to those indicated in Section 3.1, where the basic operating principles are explained in some detail.

The analysis of this circuit would be only a few minutes work were it not for the presence of the reactive tuning elements. In addition to shaping the output in order to eliminate distortion, the presence of elements capable of considerable energy storage presents a potential source of magnetizing voltage to the reactor. It is this effect which is responsible for the fact that the switching times are not straightforwardly determinable in time, and the circuit does not readily lend itself to a difference-equation solution. It is also due to this fact that output voltages can be realized which reach almost the magnitude of the input voltage, rather than the significantly smaller magnitude which would be anticipated from a Fourier analysis of the basic waveform of Figure 3.14. The saturable reactor in this application was treated as a switching element whose action is determined by the volt-time integral appearing across its terminals and by the current flowing through it, as indicated in discussion of Section 1.5.

It is necessary for the sake of logical presentation of results that a few parameters be chosen by which the circuitry of the tripler can be characterized. Firstly, if significant power is to be drawn from the

tripler, it is obviously desirable to have as high a voltage as possible at the output terminals. This immediately dictates the presence of a series capacitor, in order to conjugate the inductive output impedance of the switching section of the circuit. Note that the power output and the output voltage will also dictate the magnitude of the apparent load resistance. This will be facilitated if we note that in triplers with series and parallel tuning, the output voltage of the tripler will invariably be on the order of 80 percent to 100 percent of the input voltage. Under these conditions, the optimum absorptive characteristic of the reactor has been determined by experimental and computer solutions to be such that the reactor fires at an angle of about 120° of the input half sine-wave. From Faraday's law, this can be shown* to dictate that the product of number of reactor turns and the core area in square centimeters equals about $1000 \frac{E}{F}$, where E is the peak magnitude of the sinusoidal input voltage and F the input frequency. In a highly peaked case, where a low ratio of $\frac{\sqrt{\frac{L_2}{C_2}}}{R}$ is used in the parallel elements, a minor loop of the core is traversed, as mentioned in Section 1.6, so that less time is available for traversal of the complete hysteresis loop, and fewer turns are necessary; of the desired product of turns and area can in many cases be reduced to

*See appendix

500 $\frac{E}{F}$.

An approach to the selection of a reactor core can be formulated from the efficiency viewpoint. Knowing that a core of the types herein considered (Orthonol, Hypernik V, etc.) have core losses of about 1100 ergs per cubic centimeter per cycle, we can increase the loss figure to account for the traversal of additional minor loops per cycle plus the fact that the loop is widened for a non-sinusoidal waveform, and hypothesize the core loss to be about 2000 ergs per cubic centimeter per cycle. Now, although it is plain that the "switching efficiency" of a reactor depends upon how far into the saturation region it is driven, we can note from experience that core losses in the reactor generally amount to about 5 percent of the output power. Thus, the core must be selected such that its volume in cubic centimeters be approximately $\frac{250}{F}$ times the desired output power, F again being the frequency of input power.

With the core volume, and product of cross-section area and number of turns determined, there remains the question of selecting the number of turns and the mean length of the core. A low number of turns is desirable from the standpoint of minimizing I^2R losses in the winding, but undesirable in that it increases the magnetizing current. Probably the most expeditious approach is to choose that core of the proper volume with the

shortest mean length, and investigate whether sufficient windings (of very large gauge) can be wound upon the core to satisfy the condition that the product of core area and number of turns equals between 500 and 1000 times $\frac{E}{F}$. If this is satisfied, and the indicated magnetizing current* is not excessive (5 percent of the output current would be a reasonable limit), the core probably is about optimum.

From the elementary explanation of Section 3.1, notice that the component of load voltage in the unsaturated case is reduced from line voltage. This occurs also in the transformer tripler. Then, if a ratio of mutual inductance to primary self-inductance of 1:1 is used, the average load voltage in each equivalent state will be approximately equal. In practice, this has given quite satisfactory results. Then, the option remains whether to wind the transformer such that its secondary has a high leakage inductance, or to use a closely-coupled transformer with supplementary series inductance. It is suggested that the tight-coupling case is the most convenient to instrument, as a 1:1 turns ratio will give very nearly the 1:1 voltage condition if wound on a magnetic dust-core, the coefficient of coupling generally being in the vicinity of 0.95. The total number of turns and character of the dust-core can be chosen rather simply; assume a volt-

* See appendix

ampere efficiency (watts output divided by volt-amperes input) of one-third. This, with the given output power and voltage, will determine the approximate figure of input current. Now, the inductance of the series-aiding windings of the transformer can be chosen so that the inductive impedance at the input frequency will be about twice that of the resistive load, in order to supply the phase-shift of about 60° as noted in Figure 3.14. Then, a dust-core can be chosen as follows. From a table of dust-cores (for example, Arnold Engineering Co. Bulletin PC-104) choose one of those with permeability 125, calculate the number of turns necessary for the determined inductance, then, with the previously calculated figure of input current, check to see that the equation $NI \leq 300D^*$ is satisfied, where D is the mean diameter in inches of the dust-core. This condition is to insure that the core operates in a linear range.

The important parameters that remain are the ratios of the series and parallel **tuning** elements normalized to the load resistance.

If the tripler is to operate a reactive load, the **apparent** load impedance can be converted into an equivalent parallel impedance, the reactive parts then being deducted from the reactive elements in the tripler, while R is determined from the tripler output voltage

* See Appendix

and the power demanded by the load.

1.5 RESULTS OF THE ATTEMPTS AT ANALYSIS

The first attack made upon this problem was a uninformed method of difference-equation solution. This method, which relied upon the equating of circuit conditions at ~~appropriately~~ separated times in the time-solution (solving for steady-state mode) failed due to loss of numerical accuracy in consecutive solutions in five variables, these being the exciting voltage and the magnitudes of the four energy storages in the circuit. In addition, this attack relied at the start upon the assumption of a waveform of voltage similar to that of Figure 3.14 applied to the terminals of the tuning elements of the tripler, treating the remaining switching section as a voltage source. Obviously, this approach was incorrect, due to the phenomenon previously mentioned in which the reactive elements of the circuit alter the voltage at the reactor terminals.

The second attack upon the problem, a more fruitful one, was the formulation of an analog circuit to be investigated upon the computer facilities* of the Servomechanisms Laboratory. The instrumentation of this problem required that a representation of the reactor be formulated. This was done, following the example of contemporary magnetic amplifier analyses in assuming the

*

(See Reeves Electronic Analog Computer, Model C202 "REAC" the Appendix)

reactor to act as a switch so far as concerns the external circuitry. However, the reactor is an element sensitive to the volt-time integral upon its terminals and the current flowing through it, so that there must of necessity be some actual element in the computer analog of the circuit which can represent the reactor in each of its states. That is, such that the volt-time integral and the reactor current can be monitored. In this case, the reactor was simulated as a pair of resistances which will be quite high or quite low with respect to the remaining circuit parameters in its unsaturated or saturated states, respectively. The ratio of non-conducting to conducting impedances, so to speak, was chosen at about 3000 to 1, which is not difficult to realize in a square-hysteresis-loop material of the type usually employed, and represents approximately the ratio of a reactor used in some experimental investigations. This ratio of resistances, however, was the cause of considerable difficulty in formulating the computer scaling factors since the ratio represents a ratio of gains which must be incorporated into the computer circuitry. With a ratio of gains of this magnitude to be changed during the solution of a problem, and the requirement that circuit parameter levels be maintained during switching, there is a careful compromise to be made in deciding the level at which the computer should be operated, since the computer must

not be allowed to saturate in the high-gain operation, and the voltage levels must be kept significantly above the noise level in the low-gain phase of operation.

It was found, after much experiment, that these ends could be accomplished satisfactorily. The necessary operations of switching were controlled manually via observing the level of volt-time integral across the terminals of the reactor (here measured by monitoring the time integral of current through the core, multiplied by an appropriate conversion factor) and the instantaneous current through the core. Basically, the operation was simply to observe the volt-time integral until the reactor reached the calculated saturation level, hold the computer while switching the reactor analog to its saturated position, then observing the current level through the saturated reactor until it decreased to zero, at this time holding the computer while switching back to simulate the unsaturated reactor, etc.

A basic circuit, without tuning elements, was investigated first, to **explore** the validity of the solution obtained. It was found at this time that the combination of high-gain connection and the closely-coupled transformer in the circuit gave an unstable configuration of computer components* which obviated the possibility of obtaining any useful data, and temporarily suggested that the whole project was destined to little

* See Section 4.1 for details on this phenomenon.

accomplishment. This trouble was circumvented by the expedient of adding to the secondary of the transformer an inductance which is representative of a typical value employed in empirical investigations as the series tuning inductance, thus lowering the effective coefficient of coupling of the transformer. A representative waveform of circuit currents with this basic circuit is shown in Figure 4.25.

Since, in this initial investigation of the problem, all switching was done manually, it was necessary to construct an exciting sinusoidal voltage source of computer elements so that the source could be held at an instant of time along with the rest of the computer elements. It was also necessary to derive the time-axis of the output table from an integrator which could be held. This then meant that the complete tripler circuit as of Figure 1.41 could not readily be investigated, since there are only seven integrators in the REAC facility which are instrumented to be held, and the seven are used when the basic circuit is constructed with one additional tuning element. Provision is however made that four other amplifiers in the REAC can be externally instrumented to operate as holding integrators; the controlling relays, condenser, and input resistors must be supplied externally.

1.6 CONCLUSIONS

It has been adequately shown that an analogue computer solution to the frequency multiplier problem can indeed be carried out. A satisfactory representation of the saturable reactor is a pair of resistances which are very high or very low, respectively, when the reactor is being simulated in its unsaturated and saturated states. The switching action between these states is controllable, as in the actual operation through observing the instantaneous states of voltage integral across the reactor terminals, and the direction of the current flowing through the reactor.

Some caution must be taken in simulating the switching actions, since, as mentioned previously, the voltage which appears at the reactor terminals is not a well-behaved function in time. For this reason, were an electronic means constructed for controlling the switching operations, it would require complex circuitry beyond the simple sequential circuitry which has been used to simulate a magnetic amplifier. That is, the operation of the reactor is not a simple sequence of traveling up its loop to positive B_{\max} , into saturation, then back to negative B_{\max} ; in the critically designed case it has been observed that the reactor traverses a minor loop between traversals from one extreme of B to the other.

It should be reiterated and emphasized that a switching circuit involving considerable energy storage and employing a saturable reactor switching element, is

not susceptible to analysis via difference-equation techniques since the switching times are determined by two variables, voltage and time. A graphical procedure probably is possible, but would of necessity be an iterative process, probably involving many steps in each iteration.

2.1 BACKGROUND HISTORY OF STATIC FREQUENCY MULTIPLIERS

The concept of non-rotating magnetic frequency multipliers is far from a new one. The principle was investigated around the time of the first World War,^{5,6,7,8,9} at which time the purpose was to find a means for the generation of "high frequencies" for radio transmission. In this country the investigations were promptly dropped upon the advent of the vacuum tube, but in Europe the subject was accorded some occasional attention.^{10,11,12} When the magnetic amplifier art was revived, during the second World War, the magnetic frequency multiplier again became the subject of some interest here and abroad.^{13,14,15}

The majority of these frequency multipliers employed circuitry consisting of a polyphase source which fed a common load through phase-wise symmetrical branches. The operation of these devices depended upon saturable reactors in the capacity of switching devices, the legs of the circuit operating sequentially in time as determined by the phase sequence. There have been schemes hybrid to these employed a Scott-transformer operating from a

single-phase source through a phase-splitter, the output feeding a polyphase frequency multiplier. It can easily be seen that in all such schemes, that a voltage can be generated at the load which is periodic and of a frequency greater than the original by a factor of the number of phases.

There is one single-phase tripler discussed in a U.S. patent of 1913^{*} granted to M. Joly, a Frenchman. This patent contains only a brief qualitative description of the circuit operation, the circuit being that of Figure 2.11. There is another similar circuit considered in a patent of 1928^{*} granted to O. Von Bronk, a German. There is described in later literature a single-phase doubler employed as a means of increasing the frequency of power supplied to fluorescent lighting circuits¹³, but it is admitted that this particular circuit is not an efficient one.

It should be noted here that, only recently, an extremely efficient d-c to a-c converter was disclosed^{**}. This circuit is described fully in the literature,¹⁷ and is capable of greater than 90 percent power efficiency at output frequencies about 10 kc. The author mentions that this single circuit, consisting of two switching

* See list of patents in Bibliography.

** Circuit disclosed at AIEE Conference, Summer and Pacific General Meeting, Los Angeles, June, 1954.

transistors and a saturable reactor, can deliver up to a watt of output power, which might be sufficient to supply magnetic preamplifier stages in some applications, and that when a buffer stage of amplification follows, any reasonable power can be obtained. It is also mentioned in another paper¹⁸ that this circuit readily lends itself to frequency stabilization, if such is necessary. Therefore, in applications which desire of a magnetic amplifier of very high performance, this circuit, with appropriate stabilized rectifier power supply and a frequency-compensating circuit if needed, could be utilized as a supply for powering any reasonable size of magnetic amplifier. However, in applications requiring only a nominal improvement over that obtainable by a standard magnetic amplifier circuit, it will resolve into considerations of economy, weight, and size, whether this circuitry offers sufficient margin over that performance obtainable with one or two frequency triplers, to justify its use.

3.1 BASIC OPERATION OF A SINGLE-PHASE TRIPLER

It will be assumed, for the sake of simplification, that a saturable reactor of contemporary type, having a low coercive force and a square hysteresis loop, can be considered to exhibit two values of effective impedance to a circuit; in its unsaturated state this impedance will be quite high in comparison to the other circuit parameters while in its saturated state this impedance will be quite low in comparison to the same circuit parameters. Thus the reactor can effectively be treated as a switch. Moreover, these impedances are assumed to be resistive in nature in each state. It has been pointed out in the literature¹⁹ that the apparent impedance of reactors of the type herein considered exhibits a very small phase-angle (less than 10 degrees) between its exciting voltage and current, and a vanishingly small ratio of stored energy to that energy dissipated in a period of exciting alternating voltage, which characteristics certainly appear resistive to an external observer. Obviously, the consideration should be kept in mind that these devices to obey Faraday's law during traversal of the closed portion of their hysteresis loop.

To simplify an explanation of the basic theory, the operation of a single-phase tripler will be described

in terms of a bridge circuit of linear inductors and saturable reactors. Geometrically, this circuit appears as in Figure 3.11. Electrically, due to the switching action, there are two equivalent circuits: that one (Figure 3.12) which operates when the reactors are in their unsaturated state, and that one (Figure 3.13) which operates when the reactors are in their saturated state. The operation can be simply explained in terms of the waveforms of Figure 3.14. Assume that the reactors are wound with sufficient turns that the change in flux level from negative residual to positive residual occurs at a point about 120 degrees from the zero-crossing of a half sine-wave of voltage which appears across the reactor. (Note that the reactors do not see the line voltage, but rather a voltage diminished by the drop across a linear reactor.) Then the voltage which appears across the resistor (here representing a general load impedance) will appear as a combination of these voltages which would appear singly from either of the equivalent circuits (neglecting switching transients). The effective load voltage is shown in the figure, and can be seen to be rich in third harmonic content.

Obviously, the quality of waveform of load voltage indicated is deficient. This can be improved by appropriately chosen inductors and capacitors placed, for example, in the configuration shown in Figure 3.15.

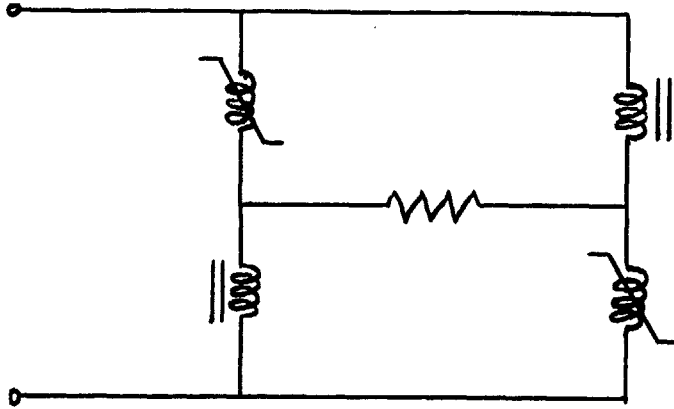

Figure 3.11 A BASIC BRIDGE-CIRCUIT TRIPLER

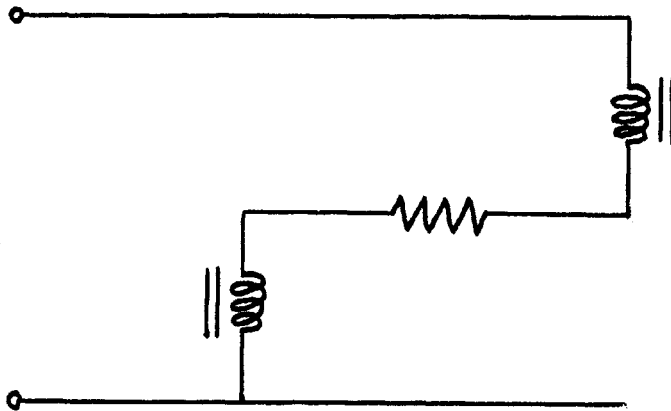

Figure 3.12 EQUIVALENT CIRCUIT WHEN THE REACTORS ARE UNSATURATED

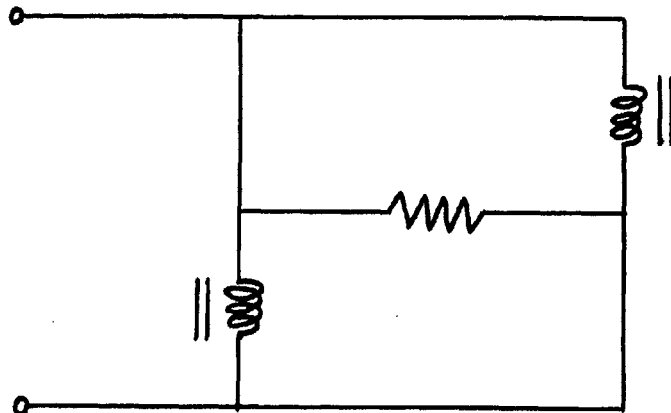

Figure 3.13 EQUIVALENT CIRCUIT WHEN THE REACTORS ARE SATURATED

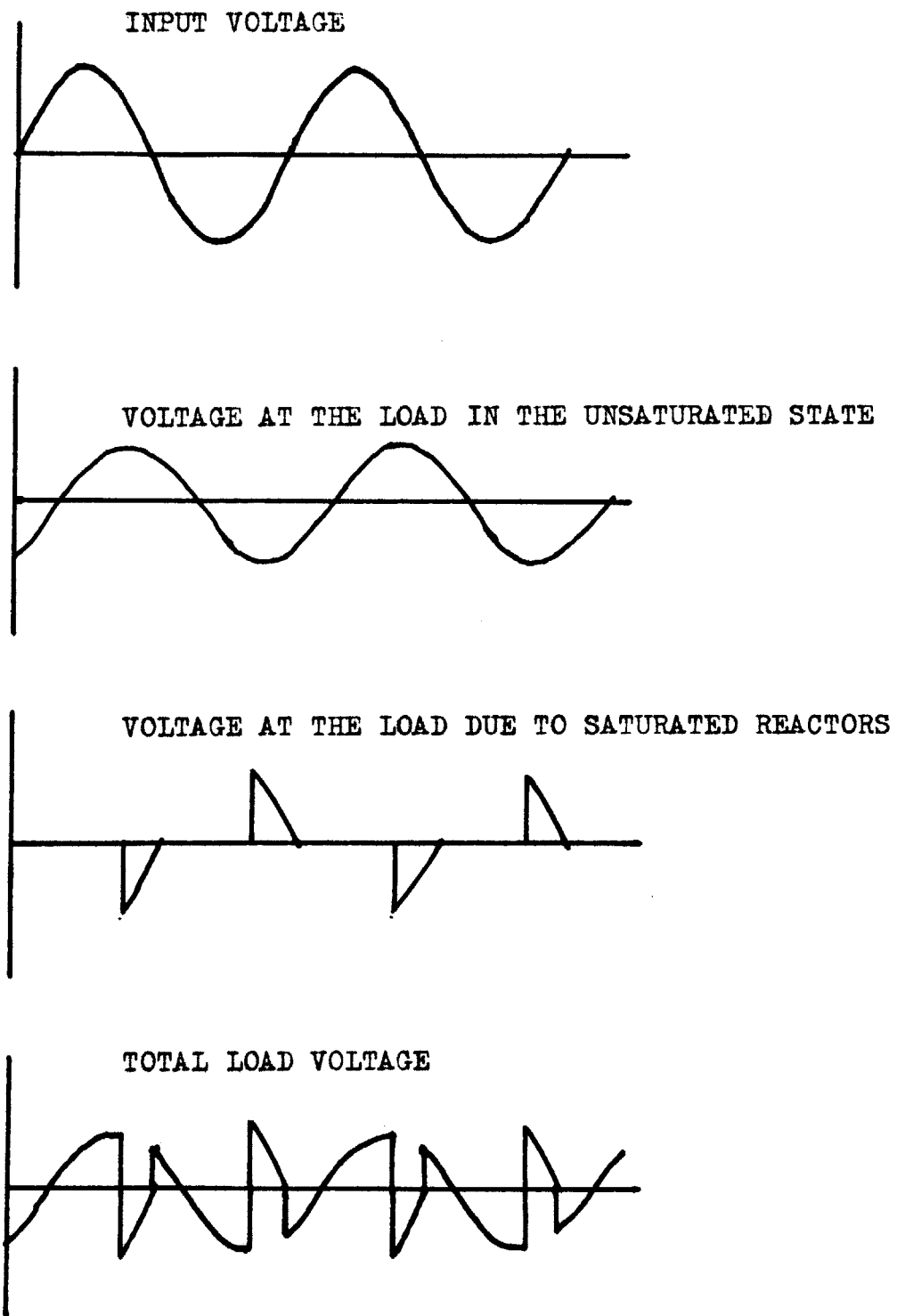

Figure 3.14 WAVEFORMS PERTINENT TO THE EXPLANATION OF BASIC CIRCUIT OPERATION

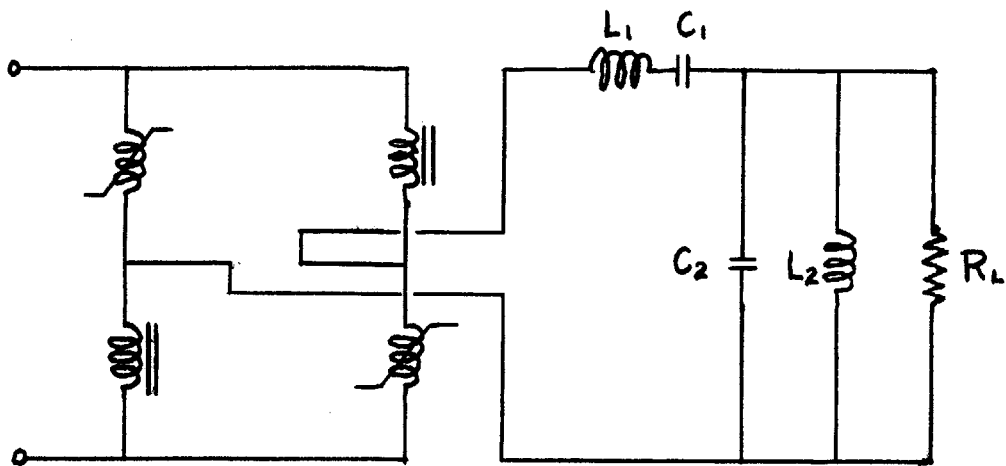

Figure 3.15 A COMPLETE BRIDGE-TYPE TRIPLER

3.2 PRACTICAL CONSIDERATIONS IN ASSEMBLING SINGLE-PHASE TRIPLERS

There are several considerations which become of importance in assembling this circuit breadboard fashion.

The so-called filtering circuits can be regarded from more than one point of view. In a sense, it may be seen that the basic elements, the switching section of the circuit may, as a first approximation, be looked upon as a driving voltage source. With this point of view, it is evident that the source has associated with it a series inductive impedance. Obviously, then, the desire for efficient power transfer between the source and a load suggest immediately the well-known condition that the load impedance be made the conjugate to the source impedance, which dictates the addition of a series capacitor between the switching section and the load. This conjugation can obviously take place at only one frequency, which is fortunate, inasmuch as it implies filtering in the sense that unwanted frequency components in the voltage of the switching source will not be coupled efficiently to the load. The condition of conjugacy requires a resonance at the third harmonic frequency, which corroborates the filtering viewpoint. Notice that the series inductor L_1 is dictated minimum by the transformer. Actually,

for the best selectivity, it is advisable here to increase L_1 considerably since in communications terminology, the selectivity is given by $\frac{\sqrt{E}}{R}$. Also, if the selectivity of this circuit R is regarded from the viewpoint of the existence of a large circulating current, this current sees a change in parameters due to switching. When the reactor is unsaturated, there appears in series with the source an inductance given by L_{11} plus L_{22} plus $2M$, but in the saturated state, the inductance of the transformer is much less. For this reason, in order to maintain resonance, it is desirable to employ a series inductor of value significantly larger than L_{11} plus L_{22} plus $2M$, so that the percentage change in tuning is minimized. Furthermore, raising the value of the series inductance obviates the necessity for close coupling between L_{11} and L_{22} with a given M ; in the experimental investigations, these were typically a few hundred turns, center tapped, on Permalloy* dust cores with a relative permeability of about 125.

The parallel tuning elements contribute nothing to the matching of impedances for purposes of gaining maximum power transfer, since in the ideal case they will be tuned to resonance at the desired third harmonic frequency, at which point their impedance becomes quite large in comparison to the load resistance.

*438281, Arnold Engineering Company

These can be looked upon, then, as a selective circuit, or filter which will tend to bypass unwanted components of frequency around the load. For optimum filtering in the parallel elements, it is apparent that the L:C ratio should be low, since, in communications terminology

again, Q_0 equals $\frac{R}{\sqrt{\frac{L}{C}}}$. However, when the previous

criterion of low L:C ratio is carried toward a limit, another practical consideration, beyond the physical size of the capacitors, becomes restrictive. This is the so-called ferro-resonance²¹ effect, a phenomenon that can occur when any non-linear inductance is coupled to a capacitor capable of high energy storage in such a way that the capacitor voltage can act to excite the magnetization of the reactor. If this condition should occur, the magnitude of the energy stored in the capacitor being the critical quantity, circuit operation can be disrupted completely, the core and capacitor proceeding to exhibit a square-wave mode of operation which can have a frequency much greater than the driving source.

The following scheme can be employed in some cases to keep the necessary value of capacity low in the event that a low voltage can be employed at the load. A transformer coupling to the load can be used, with a turns ratio greater than one, such that the reflected

resistance is lower than the actual load resistance. Since the apparent R is lowered, the selectivity of the parallel tuning circuit can be increased without increasing the L:C ratio and incurring the possibility of ferro-resonance.

It should be observed that instrumenting these circuits experimentally involves much careful thought. In the course of investigations, it was attempted to chart the loss of power in various elements. Obviously, in retrospect, a standard wattmeter was destined to failure in this application. Disregarding the fact that the wattmeters employed (Weston Model 310) were recommended for accurate operation below frequencies of 133 cps, the disrupting fact was that the inductance of the current coil is of the same order as the tuning inductors, and the circuitry became changed significantly when the wattmeter was inserted into the circuit. Although readings could be taken, having inserted the wattmeter and retuned the circuit, it would be difficult at best to normalize the power readings to the case of a specific circuit in order to study a particular power flow. An electronic wattmeter would be invaluable in this application, particularly one with an a-c frequency range extending into the kilocycle region.

It has been noticed empirically, and is apparently considered rule-of-thumb by many people in the field of

magnetic amplifiers and related devices, that a frequency multiplier of this type will demonstrate a volt-ampere efficiency inversely proportional to the multiplication factor. That is, a tripler generally shows a volt-ampere efficiency of around one third. This factor had been considered a limitation in the applicability of these circuits, but has recently been shown to be capable of elimination,* the power factor being correctable to unity through employing three more reactive elements at the input to the tripler.

4.1 THE COMPUTER ANALYSES OF TRIPLER CIRCUITS

It was stated in sections 1.5 and 1.6 that a computer solution could be carried out for the tripler circuit. Some qualifications must be made with regard to this statement.

As can be seen in Figure 4.11, a computer block diagram for the tripler circuit, there are necessary six integrators, four inverters, and six summers. The driving sinusoidal source requires an additional two integrators and one inverter, and an integrator is required to drive the time-axis of the output table. This makes a total of nine integrators, six summers, and five inverters, for a total of twenty components, which is exactly the number available in the REAC facility.

* Private correspondence to the author by Mr. J.J. Suozzi of the Naval Ordnance Laboratory, White Oak, Maryland.

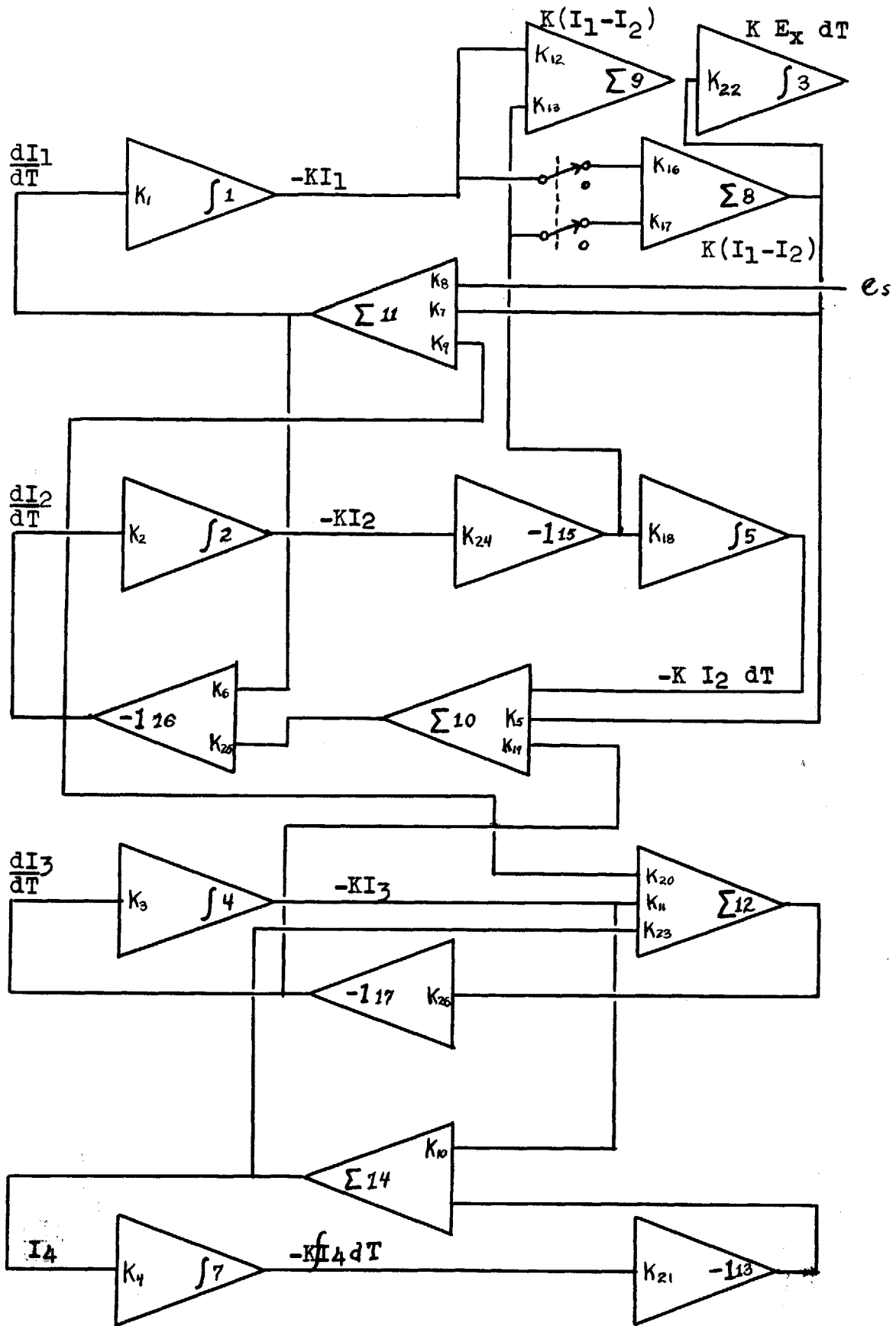

Figure 4.11 COMPUTER BLOCK DIAGRAM FOR COMPLETE TRIPLER

As can be observed in the charts, Figures 4.21-4.24, the sinusoidal source in some manner transmitted a d-c component of about one-half volt. The effect in the circuit is exactly that which would occur in the physical tripler circuit were an additional winding placed upon the reactor which carried a small component of d-c current, such that the reactor, in five or ten cycles of operation, is driven toward one end of its hysteresis loop. In some of the simpler circuit investigations this effect was compensated through summing the sinusoidal driving voltage with a small component of d-c, which artifice worked well. However, this compensation was not possible in the complete circuit, due to the lack of an available summer. Furthermore, it was found desirable in many cases, when plotting a circuit current on the output table, to magnify the current via a summer, which again would not be possible with the complete circuit.

The d-c component effect could probably be averted were the integrators selected individually in each case but this phenomenon was observed to be variable; that is, the same integrators in the sine-source would one day exhibit a d-c component, then perform well the following day. Thus a trial-and-error investigation would have to

be made each time the problem was set up on the computer. For these reasons, along with the decreasing time available, the complete circuit was never actually investigated although the circuits investigated show that the entire circuit is theoretically capable of being instrumented and investigated.

When this instrumentation is formulated the solution is an accurate one, certainly within the accuracy of an experimental investigation, for any individual set of circuit parameters. The errors in the computer solution, other than computer errors, will lie in the simulation of the reactor, which is, at first consideration, open to some criticism. It is well-known that a sinusoidal voltage impressed upon a representative reactor of 50 percent nickel, 50 percent iron grain-oriented material, a so-called square-loop material, gives rise to almost a square wave of current when the magnitude of volt-time integral which the core sees is just below that required for saturation at the end of any half-cycle. Therefore, from the sinusoidal steady-state point of view, the reactor is, when operated in this voltage region, often considered a current limiter¹⁴. Moreover, there will evidently be

a current-limiting action in an instantaneous sense when any arbitrary waveform of voltage is impressed upon a reactor, but the means do not yet exist for accurately predicting the waveform composed of the locus of instantaneous limiting values. An investigation currently in progress will attempt to show the determinacy of this locus, and obviously nature will see to it that this is a single-valued function relating instantaneous voltage and current. In this computer analysis, the only limitation imposed upon the reactor current in its unsaturated state was that the magnitude be kept quite low with respect to the magnitudes of currents in other elements of the circuit; this being accomplished by simulating it as a large resistance. The waveform of current then will be identical to that of the impressed voltage. It is felt that the resulting error in the complete circuit solution will be completely insignificant since the flow of a very small "magnetizing current", regardless of its waveform, will not detract significantly from the magnitudes or waveforms of other circuit currents. There is a secondary question to be asked here; whether going

one step further and considering that the current-time integral at the simulated reactor terminals will be equivalent to that volt-time integral which occurs in the physical case, if the reactor is simulated as a resistance. The only justification offered here, other than the fact that the results are quite equivalent to those obtainable with the physical circuits, is that, according to Reference 14, the reactor does actually appear resistive, and its non-linear magnitude can, for a period of time always less than one half-cycle, be represented by some sort of average or rms resistance* with the result that the volt-time integral in the physical case will be proportional to the current-time integral observed on the computer.

Another neglected factor is the actual inductance of a saturated reactor. It can be shown experimentally that the inductance of a saturated reactor of the types herein considered is approximately five times that which would be exhibited by the same geometric configuration of windings in a medium of air. Certainly the resulting inductive impedance in a 60 cps or 400 cps tripler will be measured in the order of tenths of ohms, so will not contribute a significant error in a circuit where the remaining parameters are measured in tens or hundreds of ohms.

*See appendix

Another disturbing effect in the computer solution should be considered. In the tuned cases investigated, either series tuned or parallel tuned, it was found desirable to minimize the starting transient of the tripler. The primary reason was to keep the solution time short in order that cumulative computer errors be minimized. If the double-tuned circulate were investigated, this might be more desirable in order to minimize the further effects of the aforementioned drift in the sine-source. At any rate, it was found that exciting the circuit with a cosine rather than a sine form of voltage greatly reduced the transient. However, doing so allows the existence of a potential throughout the analog, since the presence of what can be regarded as a d-c excitation to all elements except the integrators (whose grids are grounded in the reset or hold position) dictates the existence of a voltage distribution throughout the analog. In the physical case, this voltage represents the constant value of the time-derivative of current which exists in a circuit containing only inductances, the magnitude obviously being $\frac{E}{L}$. Moreover, when there are mutual impedances between two loops, or a series-adding mutual inductances between two loops, as in this problem, it is

simple to show that there loops formed in the computer block diagram, composed of elements handling current derivatives, which have positive feedbacks, and can on occasion sum close to unity, so that a static voltage magnification will exist in the circuit; (Figure 4.13); another stringent limitation upon the magnitude of the exciting voltage is thus incurred. For this reason, all of the curves of computer results were taken with analog voltages of less than 25 volts peak, and the majority were taken at an excitation of 6.25 volts peak. This will not contribute any error other than that due to the increased effort of noise, hum, etc. to the forms of solutions, since, assuming linearity in the physical elements, the only component which has a voltage dependency is the reactor, and as mentioned previously, the design of this element (relation of number of turns to its cross-section area) will be a direct function of the exciting voltage, and to a lesser extent, of the voltage generated in the parallel tuning elements.

Figure 4.13 is pertinent to the effect mentioned in Section 1.5, the fact that static voltage levels in the computer can be magnified by positive feedbacks in the summers of the computer. In the particular case indicated, which occurs in the parallel-tuned tripler or in the series-parallel tuned tripler, the positive

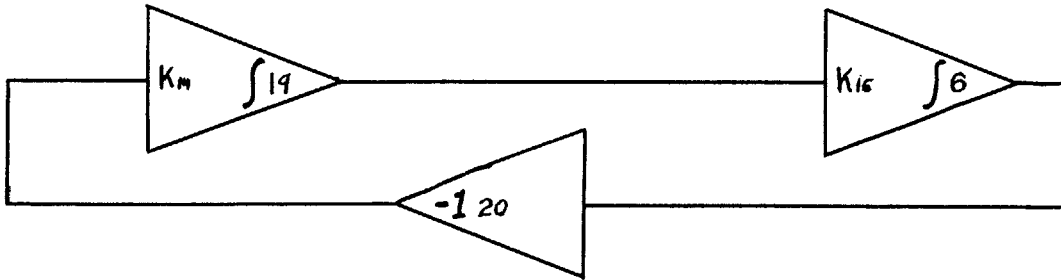

Figure 4.12 COMPUTER BLOCK DIAGRAM OF A
SINUSOIDAL SOURCE

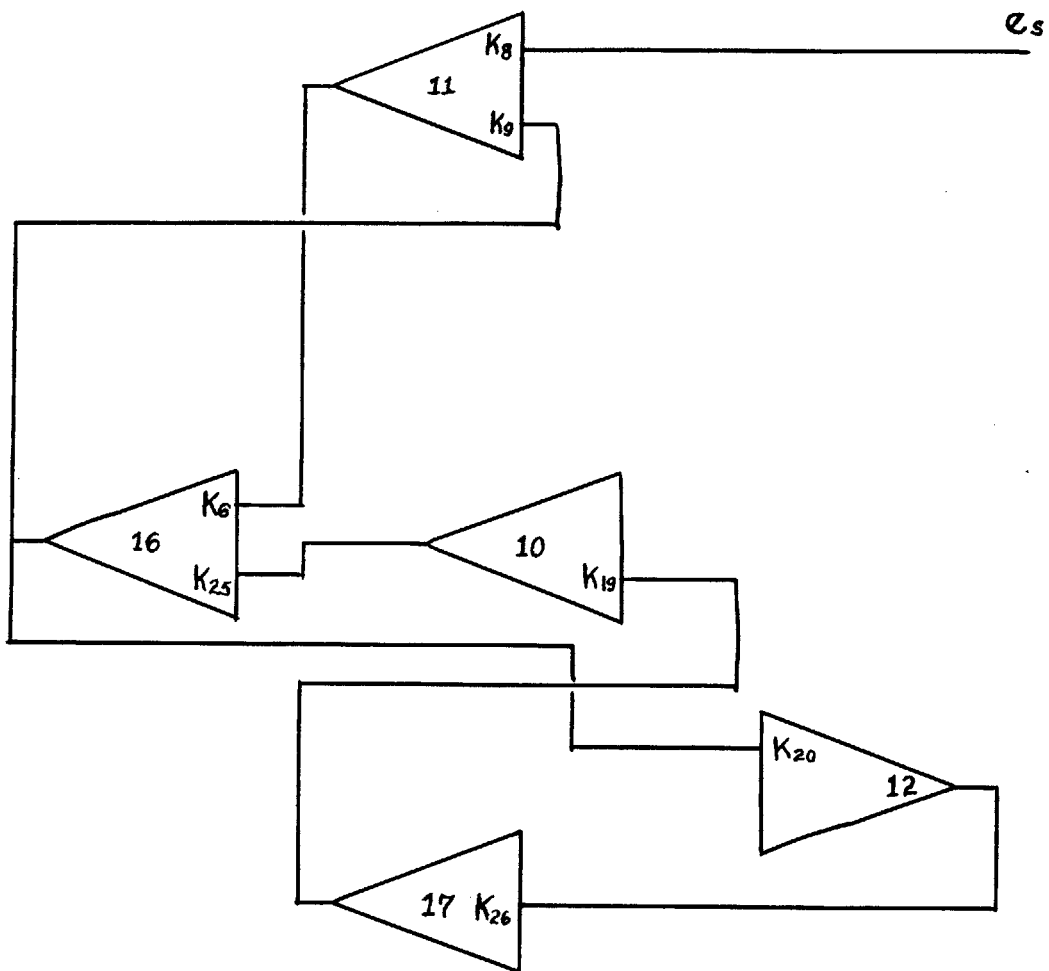

Figure 4.13 CLOSED LOOPS IN THE COMPUTER
(Pertinent to page 30)

feedbacks are obviously greater when a closely-coupled transformer is used. In a case for a circuit as on Figure 4.21, with the constants $L_{11} = L_{22} = 6.24$ millihenries, $M = 5.93$ millihenries, and $L_2 = 1$ millihenry, $C_2 = 20$ microfarads, $R = 50$ ohms, the gains are as follows: $K_9 = 0.950$, $K_6 = 0.820$, $K_{25} = 1$, $K_{19} = 0.138$, $K_{20} = 1$, $K_{26} = 1$. Then, the gain in the loop 11-16 equals 0.779, the gain in the loop 16-10-12-17 equals 0.138, both positive feedbacks. Since both loops have a common node in summer 16, the closed-loop total gain from e_s to the output of summer 16, for example is $\frac{0.95}{1 - 0.779 - 0.138} = 13$, which represents a considerable voltage magnification in the static case. Similarly, the outputs of summer 6 equals about 11.2 times e_s , output of summer 9 equals about 10.7 times e_s , etc. These static voltages which exist in the computer compel one to limit the source voltage to a respectably low value, as mentioned briefly in Section 1.5. The close coupling in the transformer is averted in the series-tuned case, since increasing the series inductance in loop i_2 of Figure 4.25 has an identical effect to lowering the effective coefficient of coupling. However, this effect caused some concern before it was understood.

The saturable reactor was simulated as saturating in all of the previous cases when $100 \int (i_1 - i_2) dt$

equalled 1.5 volts. Since e_x , the reactor voltage, equals 1500 ($i_1 - i_2$), this is equivalent to firing at a volt-time integral of 22.5 volt-seconds.

Dividing by 8000, the time scaling factor of the computer, gives an equivalent real volt-time integral of 0.00282 volt-seconds.

Now, $\int_0^{\frac{2\pi}{3}} E \sin wt \, dt$ equals $\frac{3E}{2w}$, so that for $E = 6.25$ volts and $w = 2510$ radians per second, this volt-time integral equals 0.00374 volt-seconds. If we assume a 20% of source voltage drop across the primary of the transformer, the voltage-time integral at saturation should be about 0.00299, which compares closely with the actual figure employed, 0.00282. The latter figure was used since 1.5 volts is a convenient level to monitor on the computer indicating meter.

4.2 REPRESENTATIVE RESULTS OBTAINED ON THE COMPUTER

Charts 4.21 through 4.212 are tracings of waveforms obtained on the output table of the REAC, the circuit being one with parallel tuning, as indicated on Figure 4.21. On the first figure, the currents and voltages are marked for reference. The integral of $i_1 - i_2$, the net current through the saturable reactor, is indicated since this term, multiplied by an appropriate factor representing the resistance of the unsaturated reactor, gives a measure of the flux traversal of the reactor, and is a controlling factor in the switching. It can be noted that the effective volt-time integral builds up to a point corresponding to a predetermined* saturation flux level of the reactor, then is held constant as saturation is simulated, starting downward from this level again as the difference between i_1 and i_2 approaches zero, symbolic of the current through the reactor dropping toward zero, when the core must again start integrating voltage.

The indicated current $i_3 - i_4$ is that which flows through the resistor load, and it can be seen that a fairly good sinusoidal waveform is generated at a frequency three times that of the source voltage E which is indicated on Figure 4.21. The other currents i_1 and i_2 are those indicated on the small diagram at the bottom of Figure 4.21 for reference.

On the following three figures, only the important

circuit currents are shown, i_1, i_2 , and i_3-i_4 ; the time scales and amplitudes of individual currents are the same.

Figure 4.22 was taken with identical circuit parameters as 4.21, with the exception that the reactor was simulated as saturating at 33 percent less volt-time integral. Note that the currents i_1 and i_2 are increased 10 to 20 percent, but that the current i_3-i_4 , proportional to the output voltage, is increased only about 5 to 10 percent. In this case, the reactor is over-firing, and the efficiency of the circuit would be reduced significantly.

It should be noted that the magnitude of i_3-i_4 has obviously been increased in order to make the waveform more clear.

In the circuit of Figure 4.23 the parallel capacitor C_1 was increased to 25 microfarads. Note that detuning lowers the output voltage and introduces a considerable component of fundamental frequency.

In the circuit of Figure 4.24, the parallel capacitor was decreased to about 16.7 microfarads. Note that the output voltage in waveform and amplitude is quite comparable to that of Figure 4.21, in which the tuning capacitor was 20 microfarads. This suggests that the proper value of capacitance lies somewhere between the two values. However, there is a difference which becomes of considerable importance in the series-parallel tuned

tripler; this is the phase of the output voltage, relative to the source voltage, which can be seen on scrutiny to be about 30 degrees different in the two Figures. This factor becomes of importance due to the effect previously discussed in which this parallel capacitor supplies a significant part of the magnetizing voltage to the reactor, and in practice is found to be quite significant. An analogous effect is shown quite well in Section 4.3, in Figure 4.35, where the series capacitor is varied just over 2 percent in either direction and causes in one case almost a 50 percent drop in the output voltage.

Figures 4.25 through 4.2.12 are tracings of waveforms taken on the output table of the REAC, the circuit being one with series tuning, as indicated on Figure 4.25. The two currents shown are obviously i_1 and i_2 . The load voltage would, in these cases, have the waveform of i_2 . Figure 4.25 was taken with a relatively small amount of series inductance and large series capacity, and indicates a rather sharp waveform, similar to the basic waveform as shown in Figure 3.14.

Figures 4.25 through 4.2.11 are taken with the same circuit, but the Q of the tuning circuit is progressively increased, with the exception of Figure 4.29. It can be seen that the quality of waveform increases significantly. The actual Q's of these Figures are

indicated at the bottom of the figures. The final Figure 4.2.12, is included to indicate the effects of poor tuning; in it the L_1 and C_1 were tuned to a frequency twice that of the desired third harmonic. It can be seen that there is some ringing of the tank circuit at a low amplitude, but not sufficient to warrant an attempt to multiply the input frequency greater than the efficient tripling.

The complete data for all of the charts of computer results are given in the table following the Figures.

In experimental assembly of triplers, it probably would be desirable to assume a Q of about 5 in both tank circuits initially, since this will give quite good waveform without causing great difficulty with the phasing problems previously discussed. If the resulting waveform is not satisfactory, it would be advisable to increase the series tank-circuit Q to about 10, which should give quite good results without the element values being overly critical.

Data pertinent to Figures 4.21 through 4.2.12:

In the following cases, $L_{11} = L_{22} = 6.24$ millihenries,

$M = 5.93$ millihenries, $e_s = 6.25$ volts.

Figure	R	L_2	C_2	peak i_1	peak i_2	peak e_o
4.21	50	1.0 mh	20 mf	0.4 a	0.1 a	1.7 v
4.22	50	1.0	20	0.45	0.13	1.8
4.23	50	1.0	25	0.3	0.08	1.0
4.24	50	1.0	16.7	0.3	0.08	1.7

Data pertinent to Figures 4.25 through 4.2.12:

In the following cases, $L_a = L_{22}$ plus L_1 ,

L_{11} , M , and e_s as above.

Figure	R	L_a	C_1	peak i_1	peak i_2	peak e_o
4.25	50	8	3.26	0.3	0.1	5.0
4.26	63	12	1.48	0.3	0.08	5.0
4.27	50	18	2.18	0.4	0.08	4.0
4.28	50	18	1.0	0.45	0.1	5.0
4.29	20	18	1.0	0.6	0.2	4.0
4.2.10	50	30	0.59	0.4	0.12	6.0
4.2.11	25	50	0.36	0.45	0.15	3.8
4.2.12	25	50	0.18	0.3	0.05	1.3

Figure 4.21

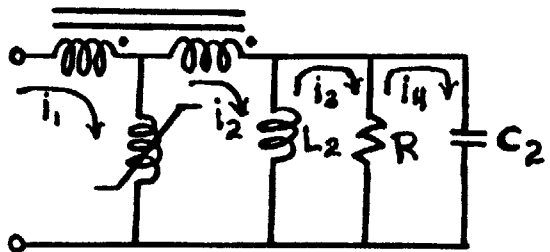
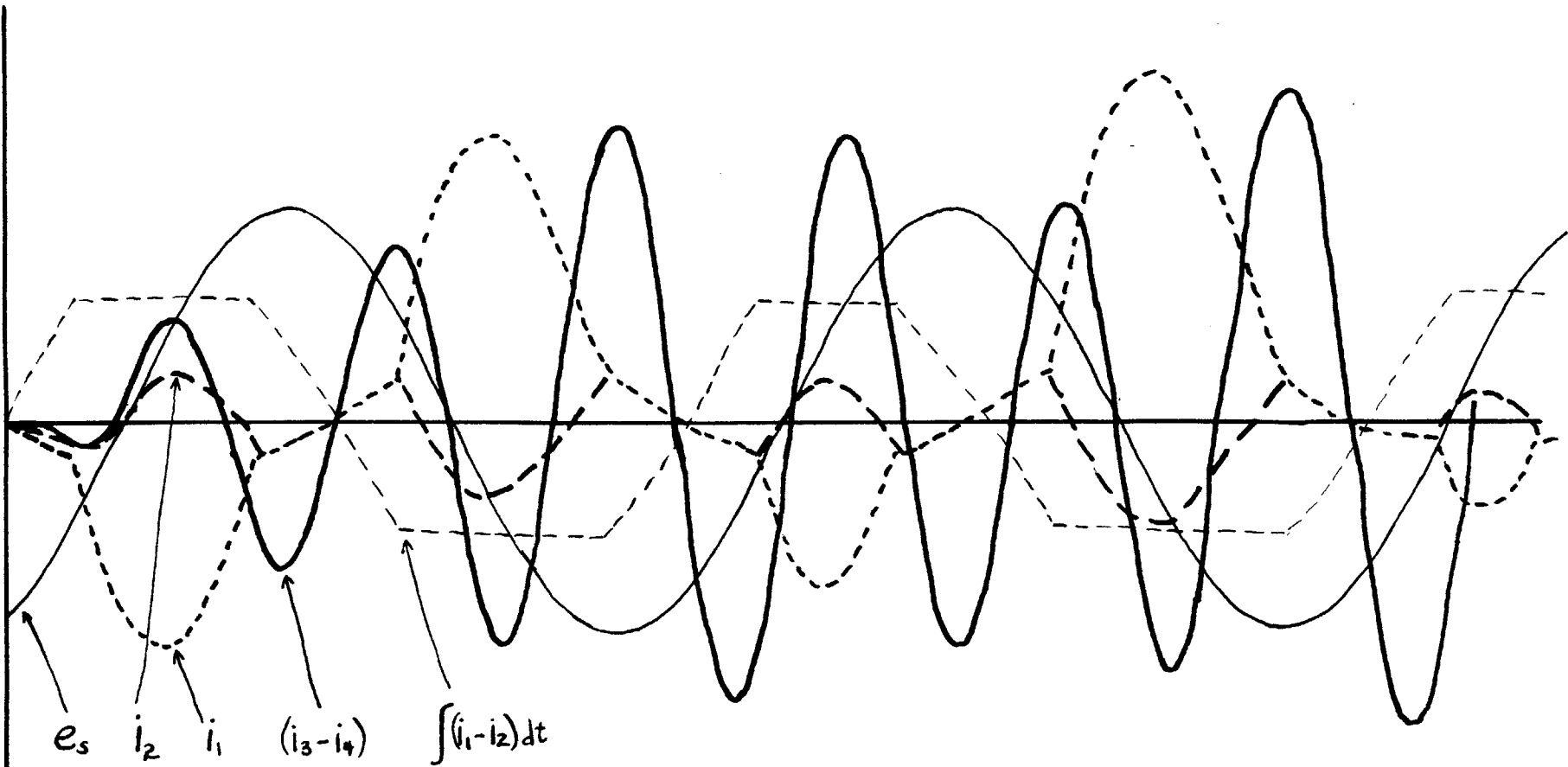

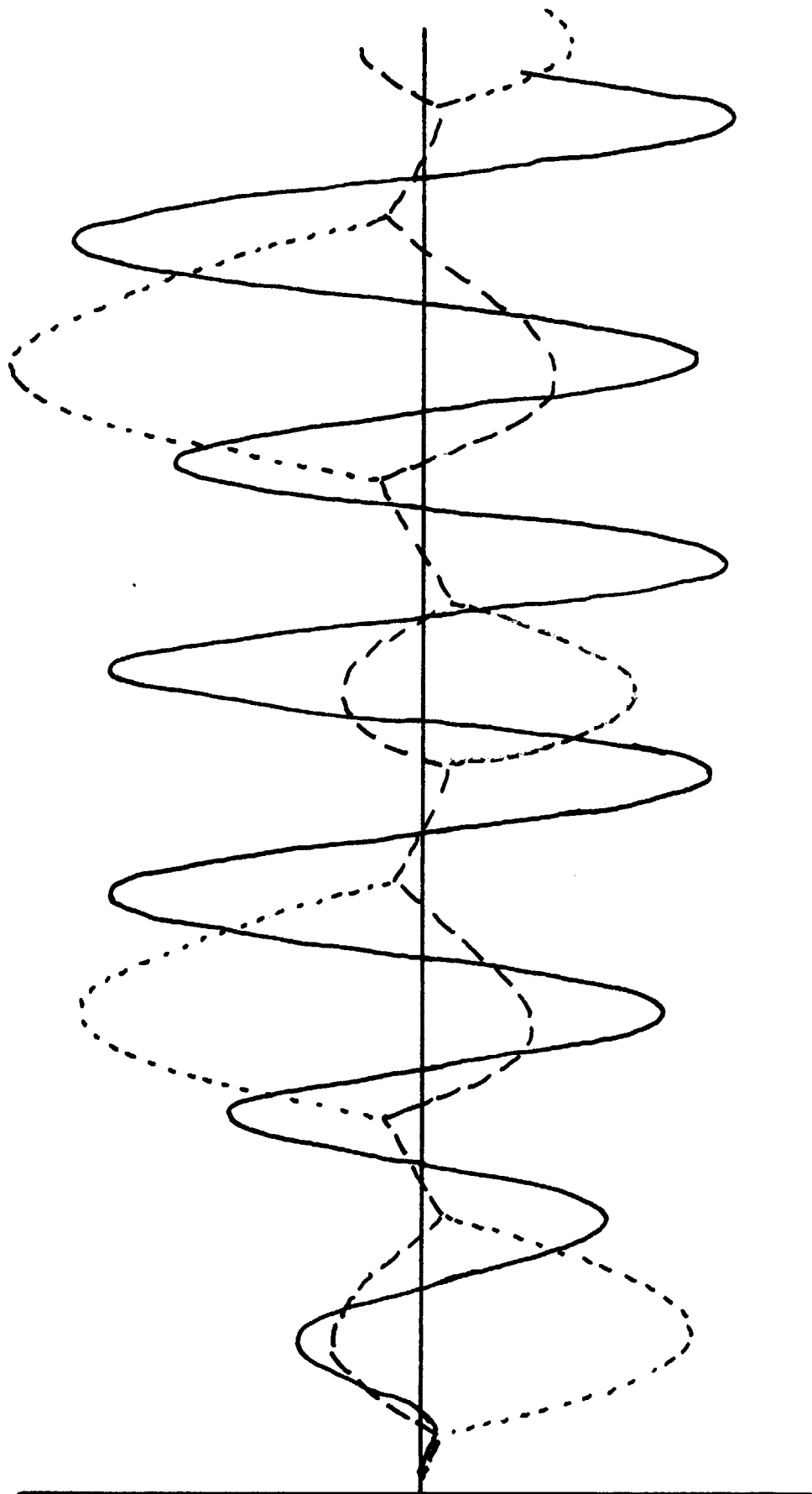

Figure 4.22

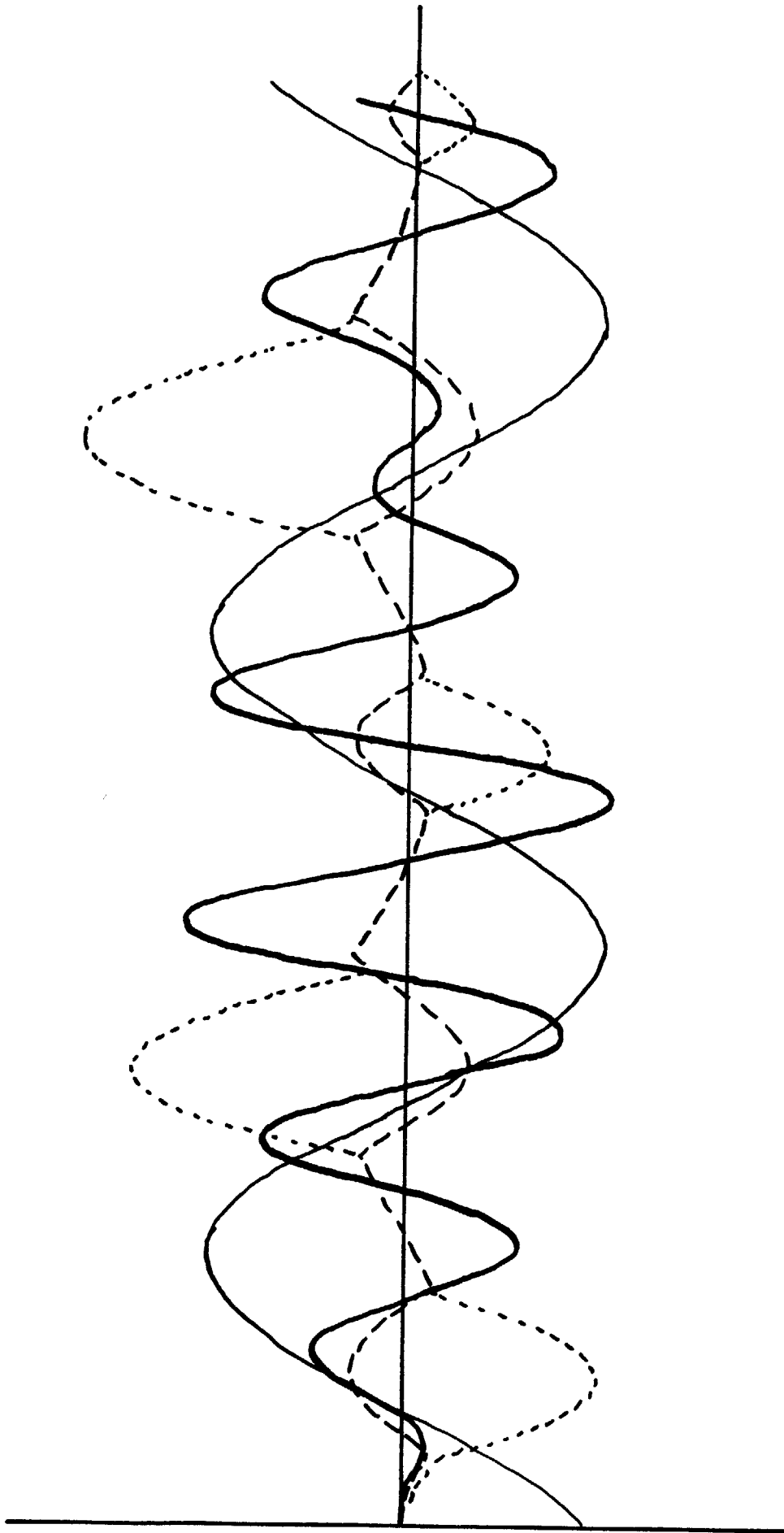

Figure 4.23

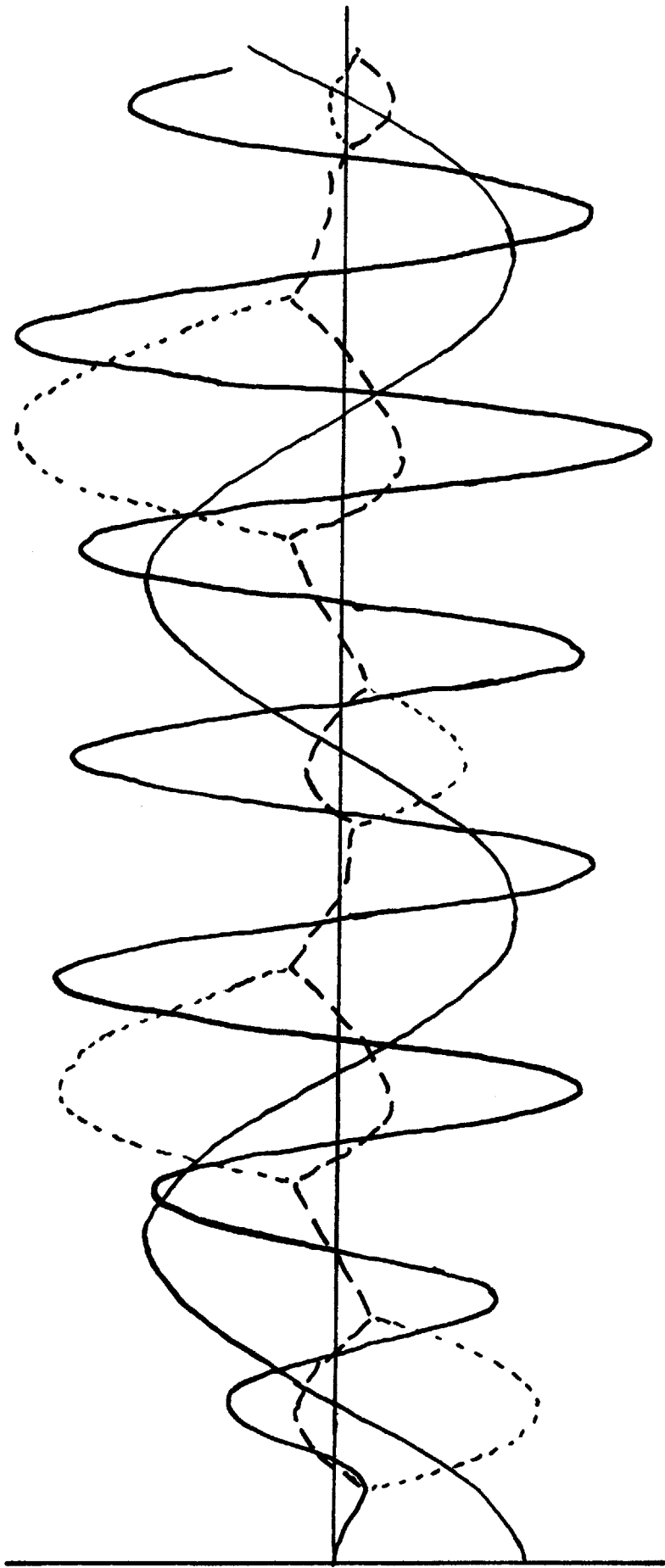

Figure 4.24

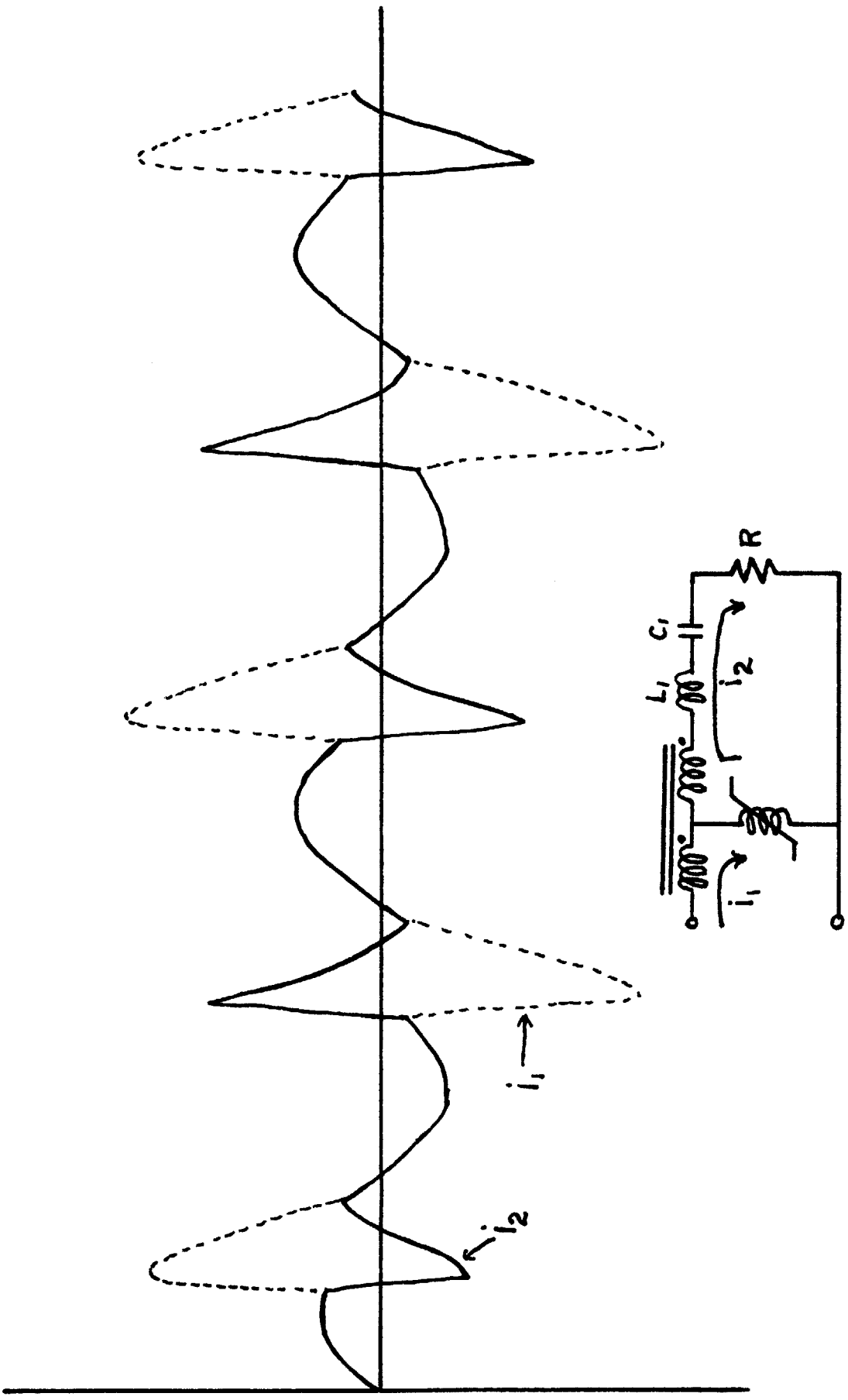

Figure 4.25 ($Q_1 = 1$)

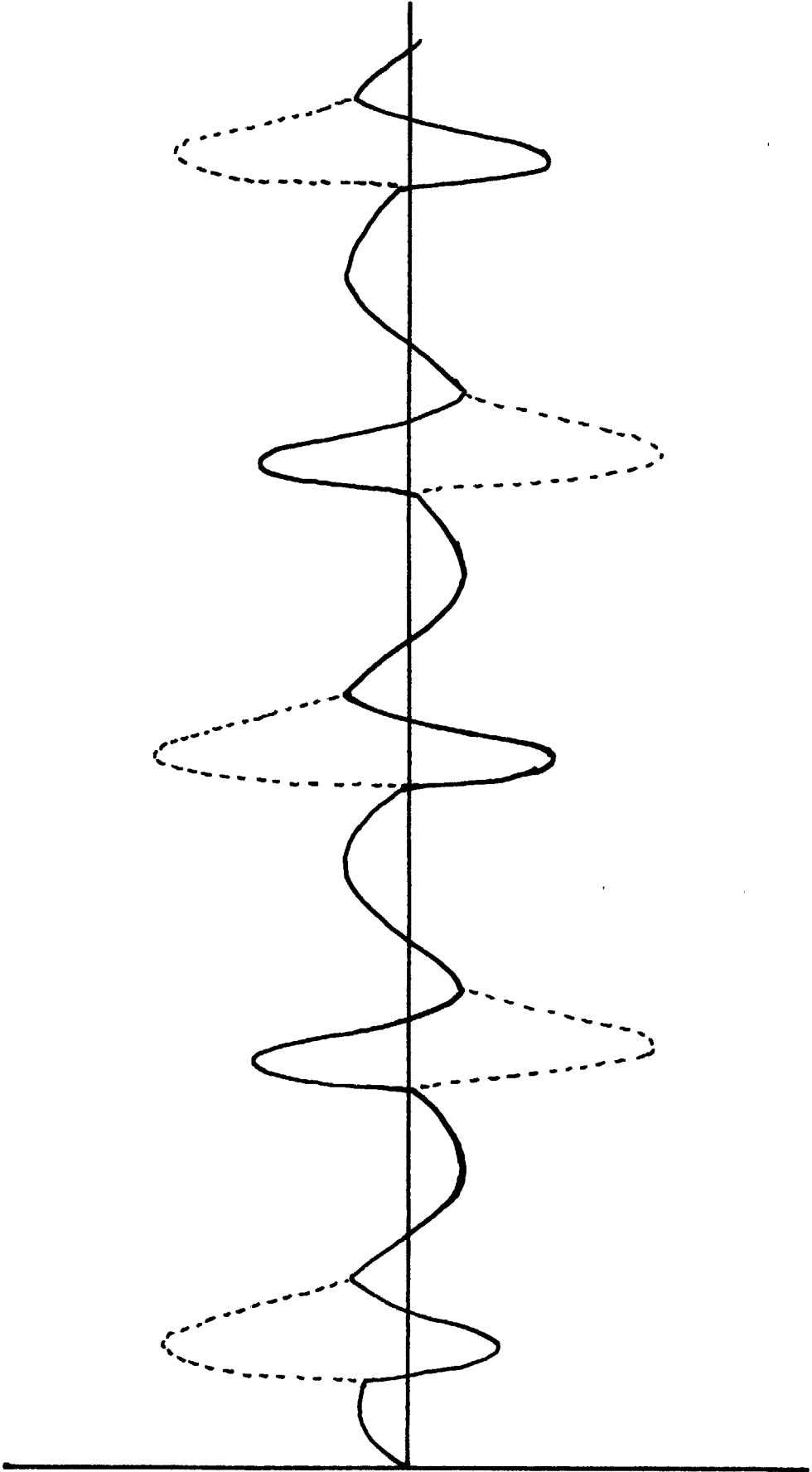

Figure 4.26 ($Q_1 = 1.8$)

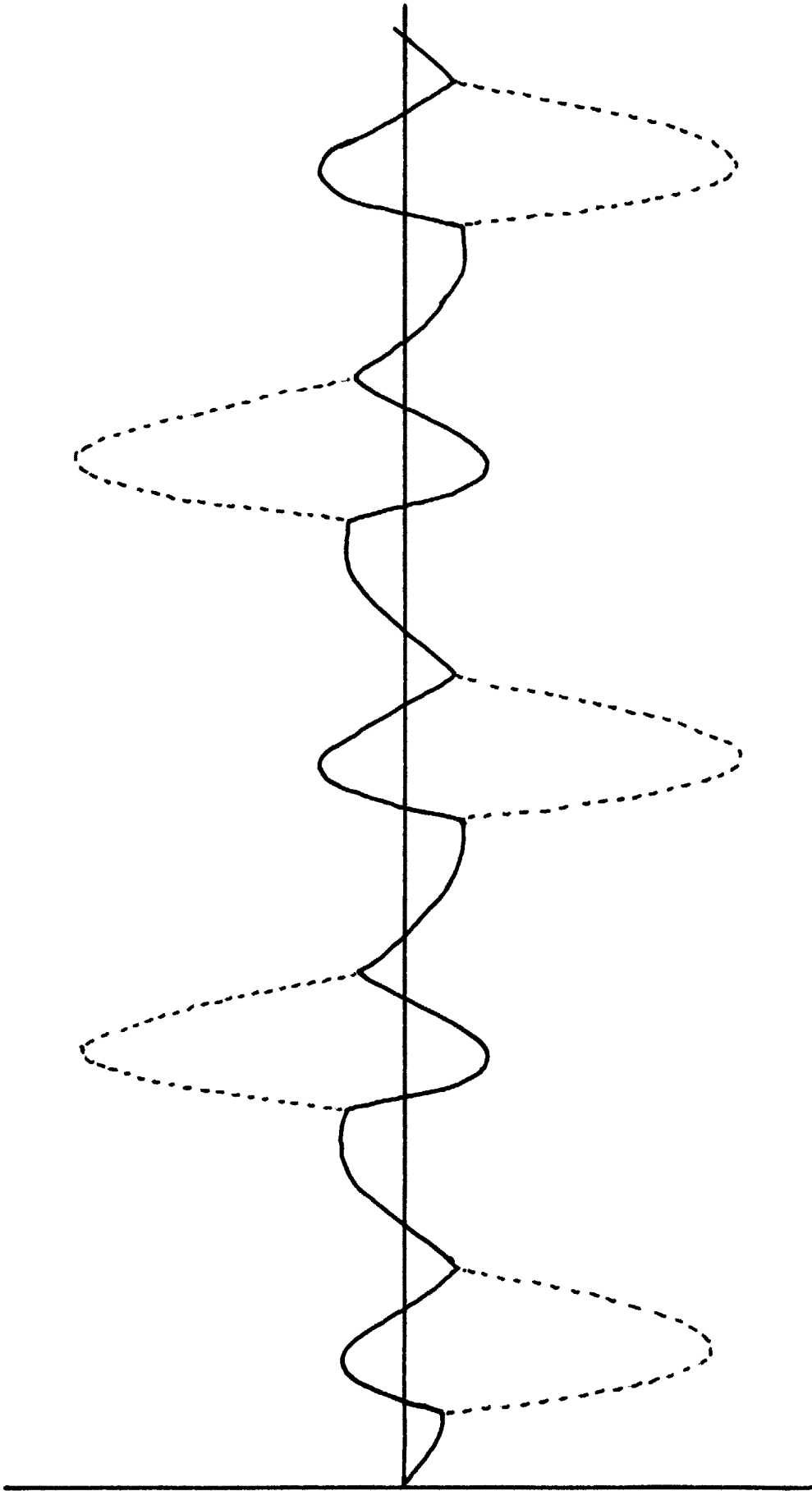

Figure 4.27

($Q_1 = 1.9$)

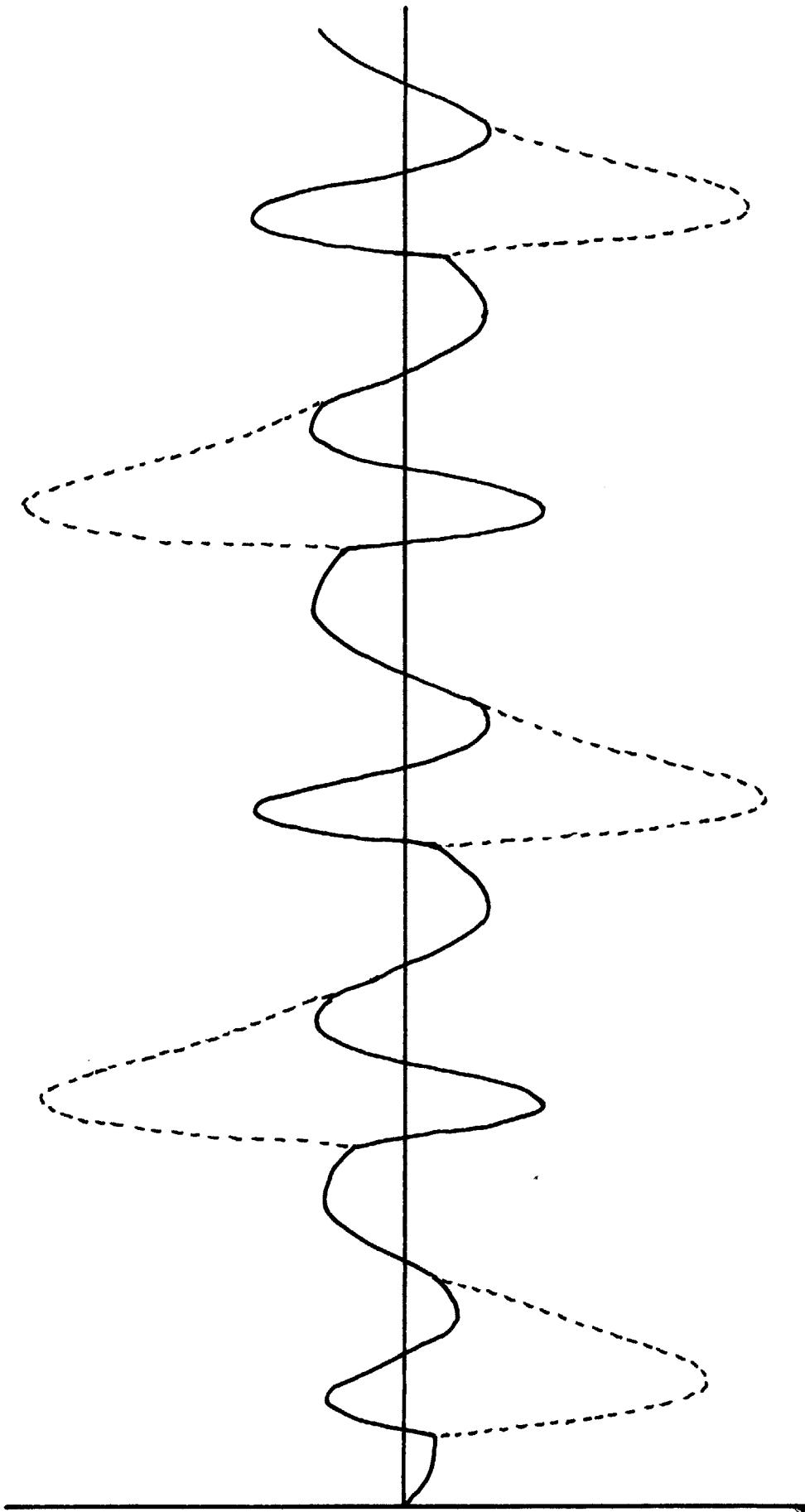

Figure 4.28 ($Q_1 = 2.7$)

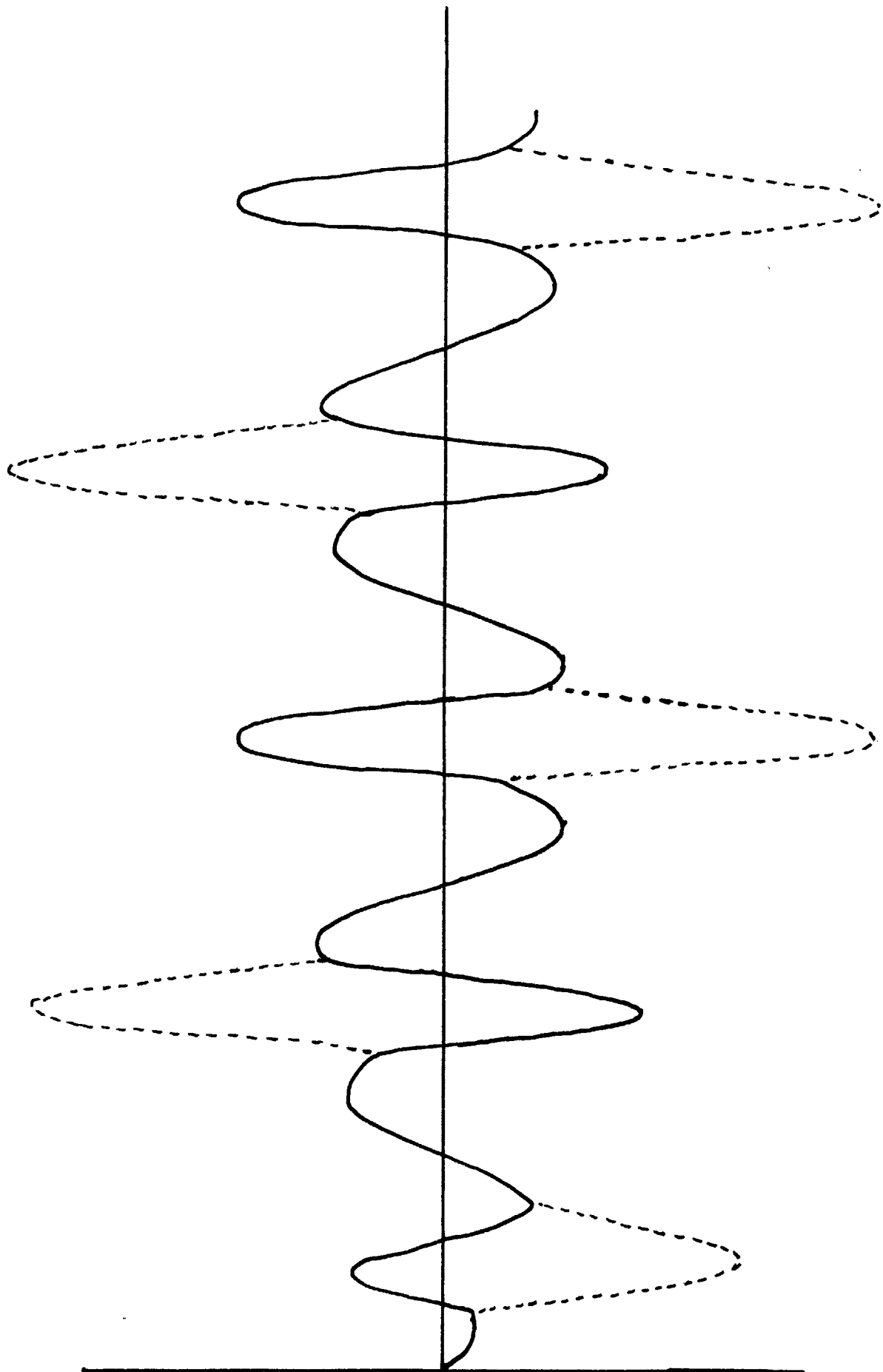

Figure 4.29 ($Q_1 = 6.8$)

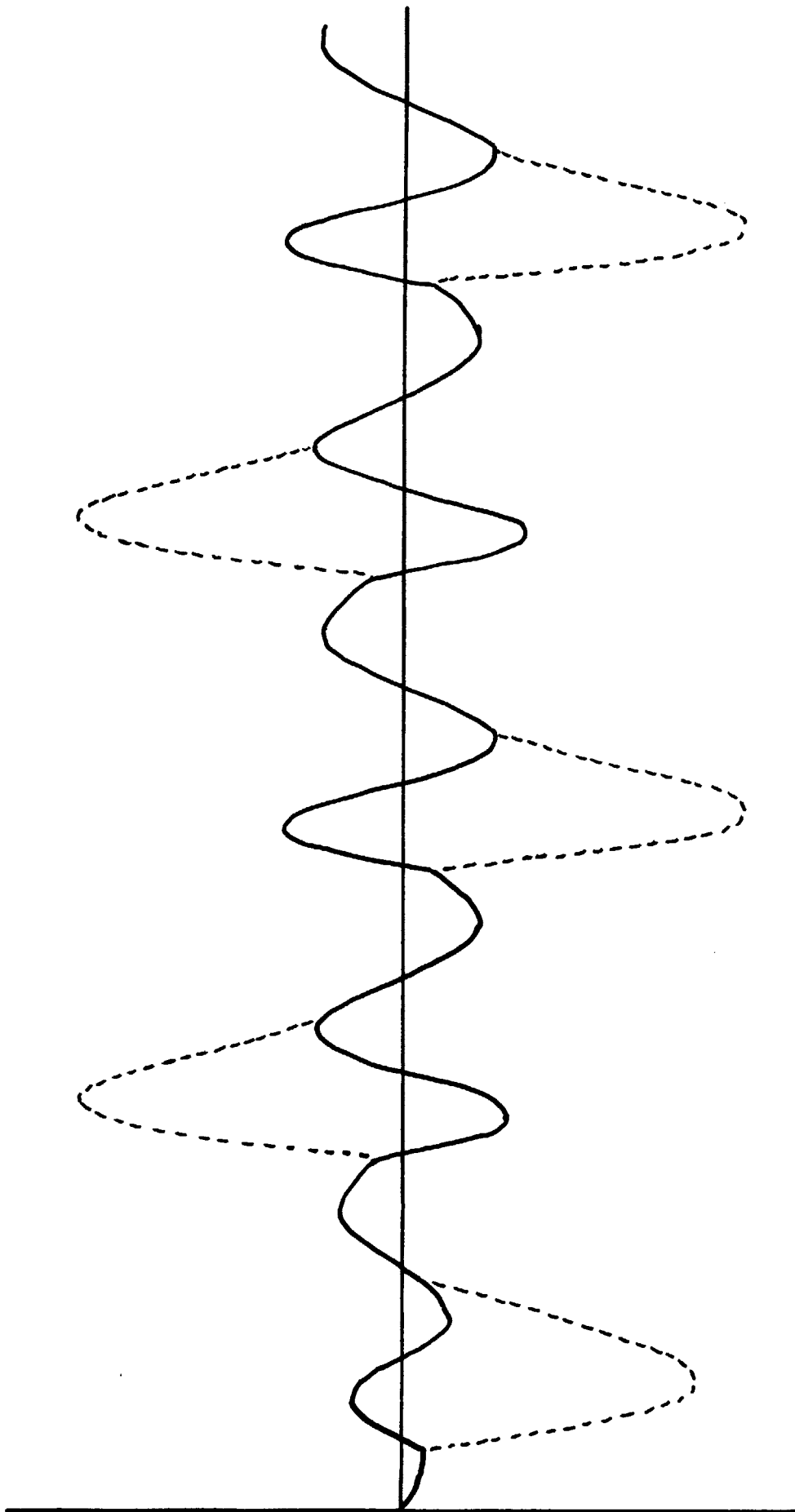

Figure 4.2.10 ($Q_1 = 4.5$)

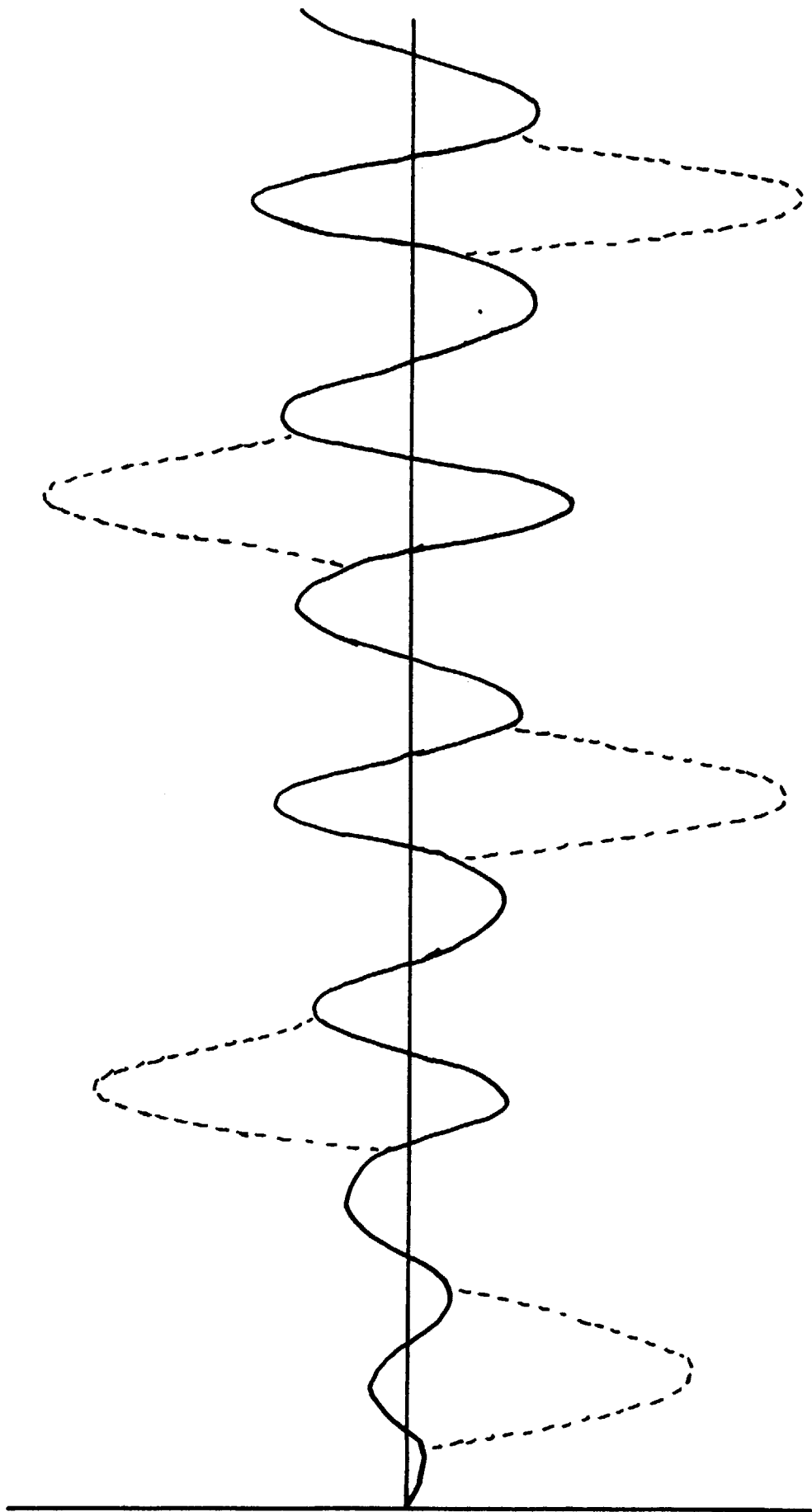

Figure 4.2.11 ($Q_1 = 14.9$)

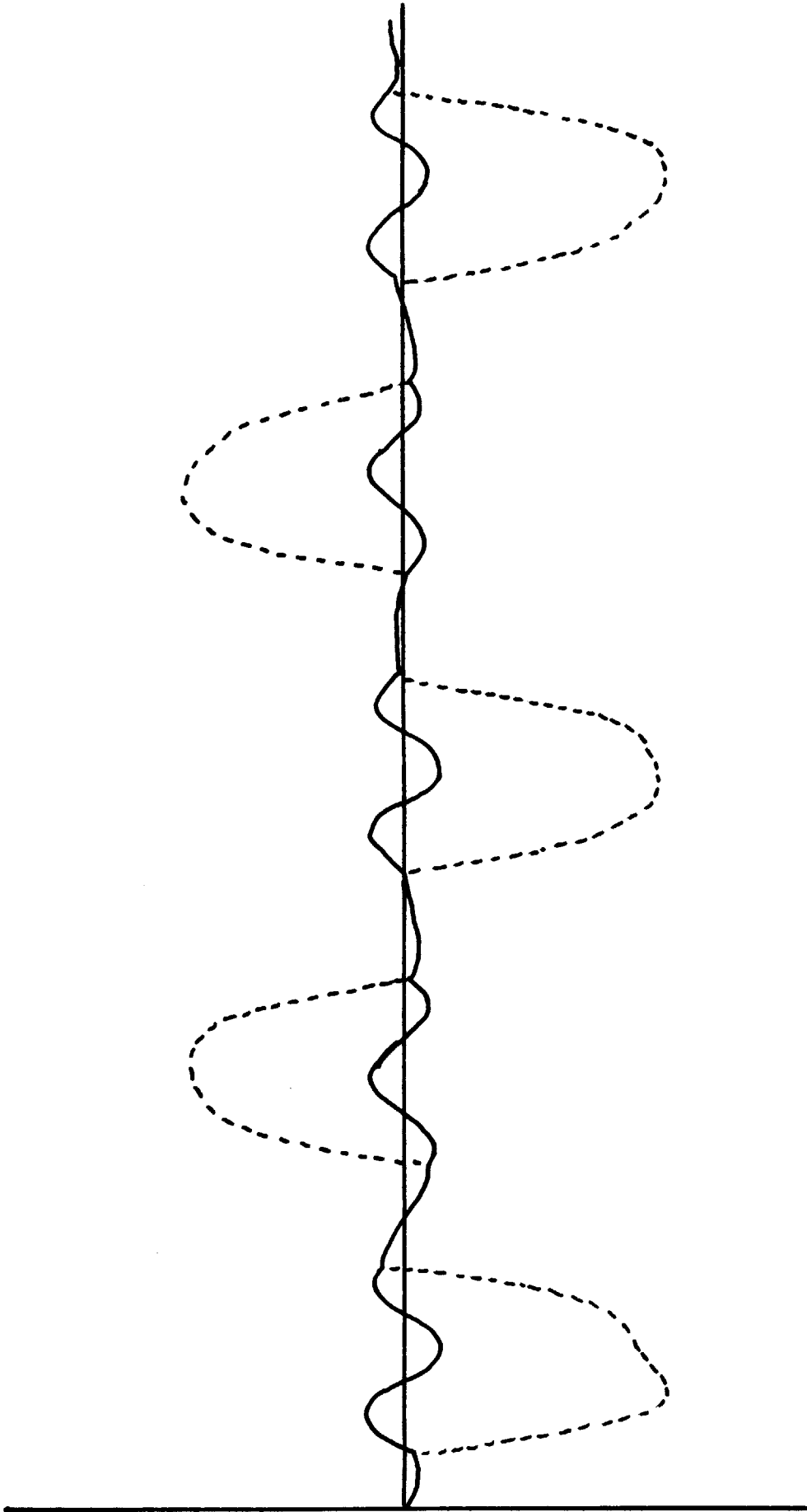

Figure 4.2.12

4.3 A FEW EXPERIMENTAL RESULTS AND THEIR COMPARISON TO THE RESULTS OF COMPUTER ANALYSIS.

Figures 4.31 through 4.37 are those obtained experimentally; the circuit being that upon which are based the values of some parameters which were used in the computer study. The representative transformer in which $L_{11} = L_{22} = 6.24$ millihenries and $M = 5.93$ millihenries stemmed from these experiments. This transformer consisted of 400 turns of A.W.G. number 18 wire wound upon two stacked Permalloy dust cores made by the Arnold Engineering Company, these cores being Arnold number 109156, having a relative permeability of 125, the dimensions being 1.40 inches L.D., 2.25 inches O.D., and 0.55 inches in height.

Other parameters in the experimental circuits are indicated in the data sheet following the Figures.

A strict comparison to the results of computer analysis is not valid inasmuch as the complete circuit was not investigated, the reasons for this being given in Section 4.1. Some comparisons can nevertheless be made in regard to waveforms, etc.

In Figure 4.21, a computer solution, only parallel tuning was employed. The particular circuit had a 50 ohm load resistor and the output resonant circuit had a Q of about 7. Part of the fundamental frequency

Data on figures relating to experimental results:

- 4.31 through 4.34, a series-parallel tuned tripler, with 50 ohm load. With $C_1 = 0.69$ mf, the circuit is well tuned, and $Q_1 = Q_2 = 3.9$.
- 4.31 Output voltage of the tripler, peak amplitude about 43 volts.
- 4.32 Current in saturable reactor, measured via the drop across a series 0.1 ohm resistor. Peak amplitude of about 10 amperes.
- 4.33 Current in the series inductor, measured via a 0.1 ohm resistor, with two modes of tuning; in the top trace $C_1 = 0.69$ mf, below, $C_1 = 0.59$ mf.
- 4.34 Voltage to tuning circuits, again taken with $C_1 = 0.69$ and 0.59, respectively.
- 4.35 through 4.37, a different circuit under three stages of tuning; varying C_1 from 0.45 mf, thence to 0.43 mf, thence to the correct value, 0.44 mf.
- 4.35 Output voltage, 17, 30, and 32 peak volts, respectively.
- 4.36 Current in saturable reactor, measured via series 0.1 ohm resistor.
- 4.37 Current in series inductor L_1 , again observed via 0.1 ohm resistor.

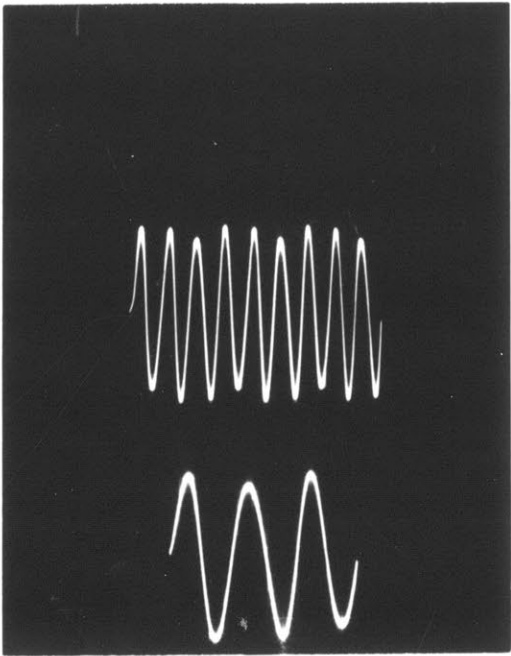

Figure 4.31

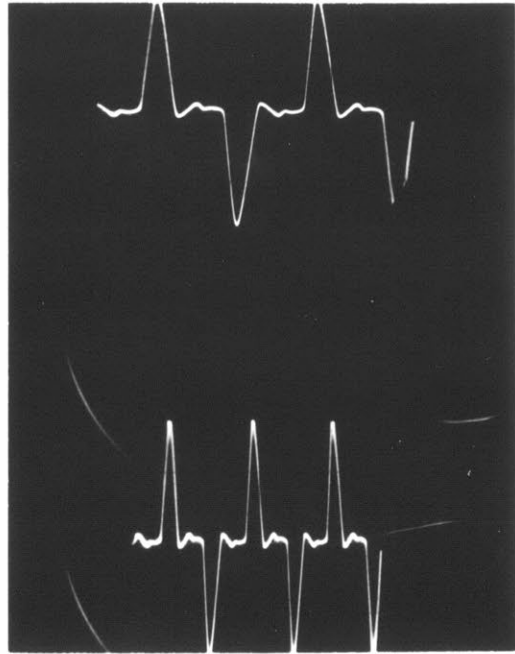

Figure 4.32

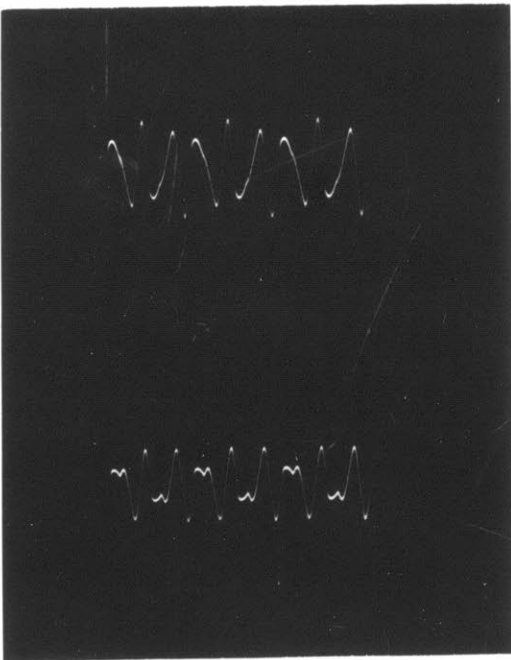

Figure 4.33

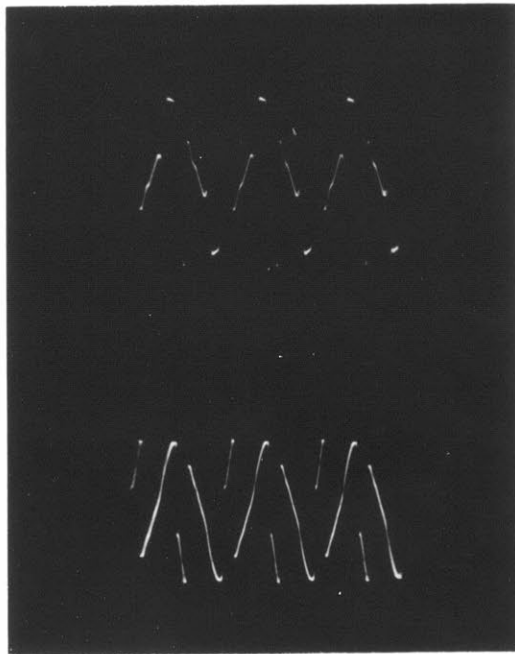

Figure 4.34

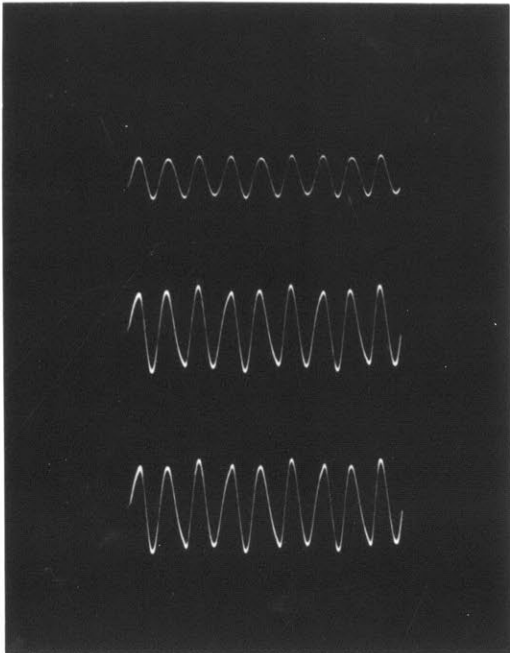

Figure 4.35

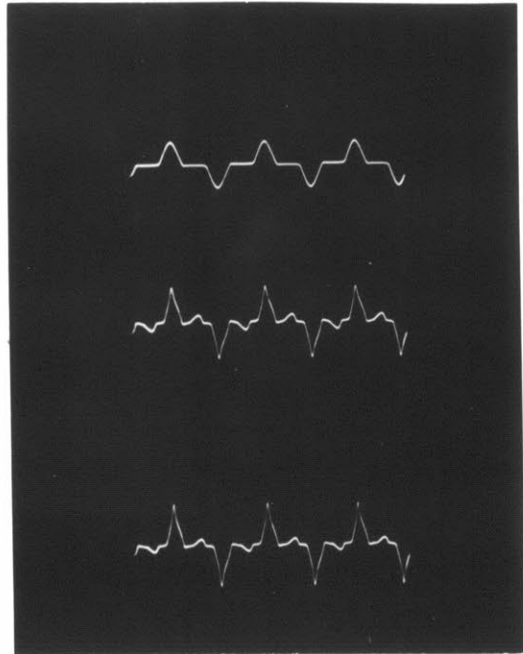

Figure 4.36

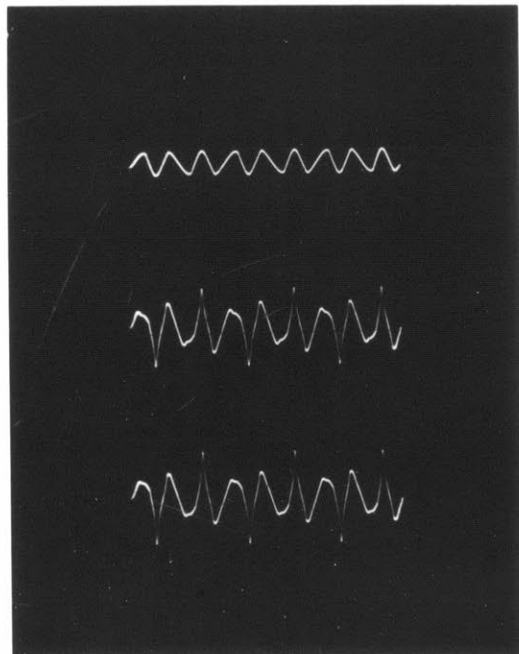

Figure 4.37

component which appears on this figure may be due to the d-c bias in the source, but the amplitude rise in the last cycle indicates the definite existence of a fundamental component. Contrast this waveform with that of Figure 4.31, an experimental series-parallel tuned tripler which had a 50 ohm load resistor and both series and parallel tuned circuits of Q about 4. With regard to the input current in these circuits, note that i_1 in the experimental circuit had a peak amplitude of about 10 amperes while the corresponding i_1 in the computer circuit had a peak amplitude of about 0.4 amperes. This gives a ratio of about 25, corresponding to the fact that the ratio of source voltages in the two cases is the ratio of 141 to 6.25, or 22.5.

Turning now to Figure 4.27, a series-tuned tripler with Q of only 1.9, a definite comparison can be made between the saturable reactor current as in Figure 4.32 (top trace) and i_1 in Figure 4.27. The series inductor current at the top of Figure 4.33 also is closely identifiable with that of i_2 in this figure. Note that the lower traces in Figures 4.32 and 4.33 were taken for detuned circuits; no analogous waveforms were investigated upon the computer. Note, however, the close similarity of i_2 in Figure 4.27 and the upper trace in Figure 4.37 (a detuned series-parallel tuned experimental tripler).

The upper trace in Figure 4.36 is of the current through the saturable reactor in a slightly detuned case. The significant thing here is the flatness in the trace during the non-conducting period, illustrating the current-limiting property of the reactor in its unsaturated state.

Going on to the traces of Figure 4.36, it is illustrated very graphically that the reactor can exhibit saturation more than once in a half-cycle of the source frequency. This is the effect discussed previously in which the reactor cycles around a minor hysteresis loop before proceeding toward saturation in the opposite direction.

Further comparisons were impossible due to the failure to obtain more photographs of experimental results. However, those comparisons made are sufficient to illustrate that a completely workable model of the tripler can be investigated upon an analogue computer, provided that supplementary external circuitry is constructed to convert a few of the inverters to integrators, and that time be allowed for carefully choosing the integrators to be employed as a source of sinusoidal voltage such that a very nearly balanced source is employed throughout.

5.1 Appendix

a, Determination of saturable reactor volume:

Assuming a core-loss of about 2000 ergs per cubic centimeter per cycle in tripler usage:

For 5% of total power loss to occur in the core,

$P_{out} = 19$ times core loss.

$$\frac{2000 \text{ ergs}}{\text{cm}^3 \text{ cycle}} \cdot f \frac{\text{cycles}}{\text{sec}} = \frac{0.002 f}{\text{cm}^3} \text{ watts}$$

$$\text{Then, } P_{out} = \frac{0.038 f}{V} \text{ watts, or}$$

$$V = \frac{P_{out}}{0.038 f} = \frac{250}{f} P_{out}$$

b, Determination of product of number of reactor turns and cross-section area:

From Faraday's law, $E = 4.44 \cdot 10^{-8} NfAB_{max}$

For Orthonol, $B_{max} = 14,000$,

$$\text{Therefore, } NA = \frac{10^8 E}{f B_{max}} = 1610 \frac{E}{f}$$

The reactor sees a voltage at its terminals of about 80% of line voltage, and needs absorb 75% of the volt-time integral over a half-cycle:

$$\text{Therefore, } NA = 0.8 \cdot 0.75 \cdot 1610 \frac{E}{f} = 1000 \frac{E}{f}$$

c, Avoidance of saturation of dust-core inductors:

$$H = 1.26 \frac{NI}{L}; \quad NI = \frac{L H_{sat}}{1.26}$$

From the Arnold Engineering Company bulletin PC-104,
note that the knee of the magnetization curve for
cores of permeability of 125 occurs at about
50 oersteds:

Therefore, $NI = \frac{50 L}{1.26}$ where L is the mean length in cm.
or $NI \leq 317 D$, where D is the mean diameter in inches.

d, Calculation of saturated inductance of reactor:

As an example, consider a core of $1\frac{1}{4}$ inches mean
diameter and 4 inches mean length, wound with
35 turns of heavy wire:

From the Federal Radio and Telephone Co. handbook,
 $L = Fn^2D$, where F is a form factor determined by the
ratio of diameter to length and equals 0.007,
D is the mean diameter:

Therefore, $L = 7 \cdot 10^{-3} \cdot 1.225 \cdot 10^3 \cdot 1.25 = 10.7$ microhenries

Alternately, $L = n^2 \frac{\mu r^2}{9R \cdot 10 L} = 10.5$ microhenries.

For a saturated permeability of about 5, the reactance
at 400 cps = 0.133 ohms.

e, Theory of a model of the saturable reactor:

Again, as an example, choose that one used in the experimental investigations, having a mean length of 14 centimeters, wound with 35 turns:

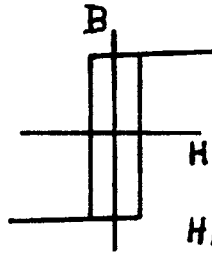

$$i_{\text{mag}} = \frac{H l}{1.26 N} \approx \frac{0.3 \cdot 14}{1.26 \cdot 35} = 0.116 \text{ a}$$

$$H_{400} \approx 0.3 \text{ oersteds}$$

An average impedance over the range to 120° :

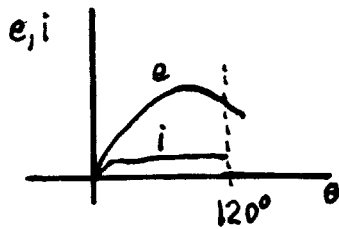

$$R_{\text{av}} = \frac{3}{2\pi} \int_0^{\frac{2\pi}{3}} \frac{e(\theta)}{i(\theta)} d\theta = \frac{3 E}{2\pi i_{\text{mag}}} \int_0^{\frac{2\pi}{3}} \sin \theta d\theta = \frac{4.5 E}{2\pi i_{\text{mag}}} = 6.19 E$$

An rms impedance:

$$R_{\text{rms}} = \frac{3}{2\pi} \sqrt{\int_0^{\frac{2\pi}{3}} \left(\frac{e(\theta)}{i(\theta)}\right)^2 d\theta} = \frac{3 E}{2\pi i} \sqrt{\int_0^{\frac{2\pi}{3}} \sin^2 \theta d\theta} = 3.82 E$$

For $E = 155$ volts peak, ($E = 117$ volts rms),

$$R_{\text{av}} = 960 \text{ ohms}, \quad R_{\text{rms}} = 593 \text{ ohms.}$$

f, Example of formulation of computer circuitry
from a physical circuit:

The circuit employed for illustration will be that
of which the results are depicted in Figures 4.31
through 4.34, in which

$$\begin{aligned} f &= 400 \text{ cycles per second} \\ L_{11} &= L_{22} = 6.24 \text{ millihenries} \\ M &= 5.93 \text{ millihenries} \\ L_1 &= 20 \text{ millihenries} \\ L_2 &= 1.8 \text{ millihenries} \\ C_1 &= 0.69 \text{ microfarads} \\ C_2 &= 11 \text{ microfarads} \\ R &= 50 \text{ ohms} \end{aligned}$$

The saturable reactor will be represented
as a two-valued resistance, whose magni-
tudes are 1500 and 0.5 ohms.

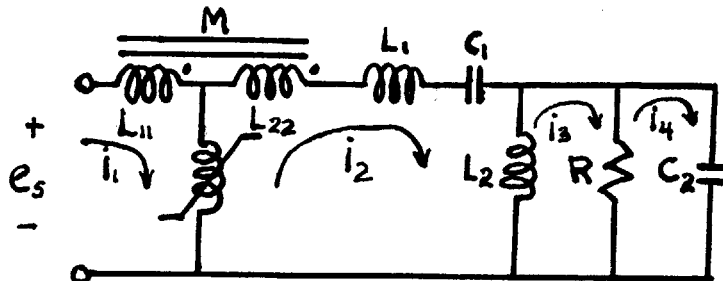

$$L_A \triangleq L_{22} + L_1 + L_2$$

$$\begin{aligned} e_s &= L_{11} \dot{i}_1 + X(i_1 - i_2) + M \dot{i}_2 \\ 0 &= M \dot{i}_1 + X(i_2 - i_1) + L_A \dot{i}_2 - L_2 \dot{i}_3 + \frac{1}{C_1} \int i_2 dt \\ 0 &= L_2(\dot{i}_3 - \dot{i}_2) + R(i_3 - i_4) \\ 0 &= R(i_4 - i_3) + \frac{1}{C_2} \int i_4 dt \end{aligned}$$

Solving for the highest derivative of each variable in
a separate equation:

$$\begin{aligned} \dot{i}_1 &= \frac{e_s}{L_{11}} - \frac{X}{L_{11}}(i_1 - i_2) - \frac{M}{L_{11}} \dot{i}_2 \\ \dot{i}_2 &= -\frac{M}{L_A} \dot{i}_1 + \frac{L_2}{L_A} \dot{i}_3 + \frac{X}{L_A}(i_1 - i_2) - \frac{1}{L_A C_1} \int i_2 dt \\ \dot{i}_3 &= \dot{i}_2 - \frac{R}{L_2}(i_3 - i_4) \\ \dot{i}_4 &= \dot{i}_3 - \frac{1}{R C_2} \int i_4 dt \end{aligned}$$

In regard to scaling factors*, it is found that the current derivatives i_1 and i_2 will have large peak magnitudes due to switching, so that it is desirable to keep the analogous computer voltages low. This suggests high integrator gains, but these were kept below 10 for the sake of stability. Three current scaling factors were therefore chosen as 10, the fourth as 1. The time scaling factor was chosen as 8000, thus simulating one cycle of the 400 cps operation in 20 seconds on the computer.

In computer technology, then, $A_1, A_2, A_3 = 10$, $A_4 = 1$, and $a = 8000$. These factors are defined in the equations $I_n = A_n i_n$ and $T = at$, where I represents a voltage in the computer analogous to a real current i in a circuit, and T represents the time unit of the computer.

Therefore,

$$\begin{aligned} \dot{I}_1 &= \frac{A_1 e_s}{a L_{11}} - \frac{X}{a L_{11}} (I_1 - \frac{A_1}{A_2} I_2) - \frac{M A_1}{L_{11} A_2} \dot{I}_2 \\ \dot{I}_2 &= \frac{-A_2 M}{A_1 L_a} \dot{I}_1 + \frac{A_2 L_2}{A_3 L_a} \dot{I}_3 + \frac{X}{a L_a (A_1 - I_2)} - \frac{1}{a^2 L_a C_1} \int I_2 dt \\ \dot{I}_3 &= \frac{A_3}{A_2} \dot{I}_2 - \frac{R}{a L_2} (I_3 - \frac{A_3}{A_4} I_4) \\ I_4 &= \frac{A_4}{A_3} I_3 - \frac{1}{a R C_2} \int I_4 dt \end{aligned}$$

* For details on the operation of the REAC, a representative analogue computer, see "Electrical Engineering Department REAC Analogue Computer Theory and Operation Manual", M.I.T. Servomechanisms Laboratory Report 6080-1, Mar. 1954.

Substituting in the values of circuit parameters
and computer conversion factors:

$$\begin{aligned} \dot{I}_1 &= 0.2 e_s - \left\{ \begin{matrix} 30 \\ 0.01 \end{matrix} \right\} (I_1 - I_2) - 0.95 \dot{I}_2 \\ \dot{I}_2 &= -0.211 \dot{I}_1 + 0.064 \dot{I}_3 + \left\{ \begin{matrix} 6.69 \\ 0.002 \end{matrix} \right\} (I_1 - I_2) - 0.808 \int I_2 dt \\ \dot{I}_3 &= \dot{I}_2 - 3.48 (I_3 - I_4) \\ I_4 &= I_3 - 0.227 \int I_4 dt \end{aligned}$$

Then, referring to the block diagram of Figure 4.11,
the computer constants can be as follows:

$$K_1 = K_2 = K_3 = 10, K_4 = 1$$

$K_8 = 0.2$ for 1:1 voltage correspondence between real
and computer cases.

K_{12} and K_{13} must be equal and can be set at a level
allowing convenient observation of $(I_1 - I_2)$.

K_{22} can be set for convenient observation of $e_x dt$

$$K_{16} = K_{17} = 3$$

$$K_5 = 0.448$$

$$K_6 = 0.211$$

$$K_7 = 1$$

$$K_9 = 0.95$$

$$K_{10} = 0.1$$

$$K_{11} = 0.348$$

K_{14} and K_{15} , determining the frequency of the source
as per Figure 4.12, = 0.314

$$K_{16} = K_{17} = 3$$

$$K_{18} = 0.081$$

$$K_{21} = 0.227$$

$$K_{19} = 0.064$$

$$K_{23} = 3.48$$

$$K_{20} = 1$$

$$K_{24} = K_{25} = K_{26} = 1$$

BIBLIOGRAPHY

PERTINENT PATENTS

Single-phase multiplier:

1. "Static Frequency Transformer," M. Joly,
U.S. patent 1,118,935, issued December 1914.
2. "Frequency Multiplier," O. Von Bronk, U.S.
patent 1,678,965, issued July 1928.

Polyphase multipliers:

3. "Frequency Multiplier," H.M. Huges, U.S.
patent 2,424,237, issued July 1947.
4. "Electric Frequency Transformation System,"
E.F.W. Alexanderson, A.H. Mittag, M.W. Sims,
U.S. patent 2,451,189, issued October 1948.
5. "Means for Increasing Frequency," F.G. Logan,
U.S. patent 2,157,396, issued August 1950.

REFERENCES

1. "Effect of Magnetic Amplifier Deadtime upon
Servo Performance" L.S. Weinstein, MIT S.M.
thesis, 1954.
2. "Fast Response Magnetic Servo Amplifier"
Fingerett and Hill, Electronics, October 1954.
3. "Pulse Relaxation Amplifier--A Low Level
Amplifier" Morgan and McFerran, AIEE Paper
54-198, July 1954.
4. "Magnetic Servo Amplifiers Employing Tripled-
Frequency Carriers" G. Schohan and R. Reichard,
U.S. Naval Ordnance Laboratory NavOrd Report
3856.

5. "Radio-frequency Changers" A.N. Goldsmith,
Proc. of the I.R.E., March 1915.
6. "A Contribution to the Theory of Magnetic
Frequency Changer" J. Zenneck, Proc. I.R.E.,
December 1920.
7. "Static Frequency Multiplier for VHF Radio"
Latour, Revue Generale de L'Electricite,
July 1922.
8. Article in Electrician, by Spinelli, Vol. 70,
1912.
9. Article by Taylor, Journal of I.E.E., London,
Vol. 52, 1914.
10. "A Contribution to Frequency Transformation
by means of Iron-core Inductors" Dornig,
Electrotechnische Zeitschrift, October 1924.
11. "Frequency Multipliers; Principles and Appli-
cations of Ferro-magnetic Methods" Lindenblad
and Brown, Trans. AIEE, Vol. 44, 1925.
12. "Frequency Changing at Supply Frequency by
Static Means" Brailsford, Journal of I.E.E.
London, September 1933.
13. "Fluorescent Lamp Operation at Frequency Above
60 Cps" Campbell and Bedford, Proc. of N.E.C.,
Vol. 3, 1947.
14. "A Non-linear Resistive Element" C.M. Davis,
Jr., NavOrd Report 2700, 1953.
15. "Magnetic Frequency Conversion" L.C. Harriott,
Proc. of N.E.C., Vol. 9, 1953

16. "Elimination of Asymmetry Zero-Drift Errors in Magnetic Servo Amplifiers" W.A. Geyger, AIEE Transactions Paper 55-73, 1955.
17. "A Switching Transistor D-c to A-c Converter Having an Output Frequency Proportional to the Input Voltage" G.H. Royer, AIEE Transactions Paper 55-73, 1955.
18. "A Variable Frequency Magnetic-coupled Multi-vibrator" R.L. Van Allen, AIEE Transactions Paper 55-75, 1955.
19. "Magnetic Frequency Multipliers" Johnson and Rauch, AIEE Transactions, March 1954.
20. "An All Magnetic Audio Amplifier System" Suozzi and Hooper, AIEE Transactions Paper 55-70, January 1955
21. "Practical and Theoretical Aspects of Ferro-resonance", R.B. Finn, Jr., and R.S. Foster, MIT S.M. thesis, 1955.