

**Invariants linked to models of curves over discrete
valuation rings**

by

Padmavathi Srinivasan

Submitted to the Department of Mathematics
in partial fulfillment of the requirements for the degree of

Doctor of Philosophy

at the

MASSACHUSETTS INSTITUTE OF TECHNOLOGY

June 2016

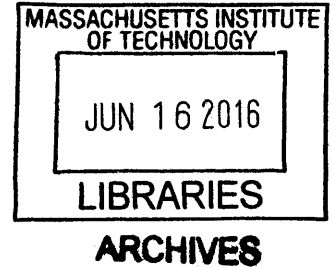

© Massachusetts Institute of Technology 2016. All rights reserved.

Signature redacted

Author

.....
Department of Mathematics
April 29, 2016

Signature redacted

Certified by...

.....
Bjorn Poonen
Claude Shannon Professor of Mathematics
Thesis Supervisor

Signature redacted

Accepted by

Alexei Borodin
Chairman, Department Committee on Graduate Theses

Invariants linked to models of curves over discrete valuation rings

by

Padmavathi Srinivasan

Submitted to the Department of Mathematics
on April 29, 2016, in partial fulfillment of the
requirements for the degree of
Doctor of Philosophy

Abstract

This thesis consists of two parts. In part one of this thesis, we study the relationship between the Artin conductor and the minimal discriminant of a hyperelliptic curve defined over the fraction field K of a discrete valuation ring. The Artin conductor and the minimal discriminant are two measures of degeneracy of the singular fiber in a family of hyperelliptic curves. In the case of elliptic curves, the Ogg-Saito formula shows that (the negative of) the Artin conductor equals the minimal discriminant. In the case of genus 2 curves, Liu showed that equality no longer holds in general, but the two invariants are related by an inequality. We extend Liu's inequality to hyperelliptic curves of arbitrary genus, assuming rationality of the Weierstrass points over K .

In part two of this thesis, we compute the sizes of component groups and Tamagawa numbers of Néron models of Jacobians using matrix tree theorems from combinatorics. Raynaud gave a description of the component group of the special fiber of the Néron model of a Jacobian, in terms of the multiplicities and intersection numbers of components in the special fiber of a regular model of the underlying curve. Bosch and Liu used this description, along with some Galois cohomology computations to provide similar descriptions of Tamagawa numbers. We use various versions of the matrix tree theorem to make Raynaud's and Bosch and Liu's descriptions more explicit in terms of the combinatorics of the dual graph and the action of the absolute Galois group of the residue field on it. We then derive some consequences of these explicit descriptions. First, we use the explicit formula to provide a new geometric condition on the curve for obtaining a uniform bound on the size of the component group of its Jacobian. Then we prove a certain periodicity property of the component group of a Jacobian under contraction of connecting chains of specified lengths in the dual graph. As a third application, we obtain an alternate proof of one of the key steps in Halle and Nicaise's proof of the rationality of the Néron component series for Jacobians.

Thesis Supervisor: Bjorn Poonen

Title: Claude Shannon Professor of Mathematics

Acknowledgments

I have been truly fortunate to have had so many wonderful, supportive mentors all through my student life. First of all, I would like to thank my advisor, Bjorn Poonen, whose patient and thoughtful guidance has helped shaped this thesis. His generosity, constant encouragement and infectious enthusiasm for mathematics have been a steady source of strength. I could not have hoped for a better mentor to help me navigate through graduate school. I would also like to thank all the faculty at my undergraduate institution, Chennai Mathematical Institute, for introducing me to the joys of doing mathematics, and for their continuing support over the years.

I would like to thank François Charles for several exciting mathematical discussions, and for all his advice during the last few years. I would like to thank Naoki Imai and Davesh Maulik for serving on my thesis committee. I would also like to thank Swati Gupta, Sam Hopkins and Melody Chan for helpful discussions regarding some of the material in Chapter 4.

I would like to thank my academic siblings, both older and younger, for their mentorship and comradery. I have really benefited from being part of such a tight-knit family. I would also like to thank all my friends for their support.

I would like to thank Dinah and Stephanie for helping me settle in during my first year. I would like to thank the wonderful staff at the MIT math department for their hospitality, and especially Barbara Peskin, for all her help during the semester I was away.

Finally, I would like to thank my family for having always stood by me, and for doing everything in their power to get through challenging times.

Contents

1	Introduction	9
2	Background and Definitions	17
2.1	Weierstrass models and minimal discriminants	17
2.2	Regular models	21
2.3	Artin conductor	21
2.4	Deligne discriminant	23
2.5	Relation between the Deligne discriminant and the Artin conductor	24
2.6	Some graph theory	24
2.7	Néron models	28
2.8	Component groups and Tamagawa numbers of Jacobians	29
2.8.1	The Artin–Winters type of a regular S -curve	29
2.8.9	Component groups	31
2.8.13	Tamagawa numbers	32
2.9	Hirzebruch–Jung continued fractions	33
2.10	Behaviour of regular models under tame extensions	35
2.11	Néron component series	38
3	Comparing conductors and discriminants	39
3.1	Construction of the regular model	40
3.2	An explicit formula for the Deligne discriminant	45
3.3	Dual graphs	47
3.4	Deligne discriminant and dual graphs	48

3.5	Description of the strategy	48
3.6	A decomposition of the minimal discriminant	49
3.6.1	Weight of a vertex	51
3.6.3	Local contribution and weights	51
3.7	A combinatorial description of the local terms in the Deligne discriminant . .	52
3.7.9	Computation of $D(v)$ for an even vertex v	63
3.7.15	Computation of $D(v)$ for an odd vertex v	71
3.7.21	Formula for $D(v)$	76
3.8	Comparison of the two discriminants	77
3.8.1	A new decomposition of the Deligne discriminant	77
4	Computing orders of component groups and Tamagawa numbers of Jacobians	87
4.1	Explicit computation of the orders of component groups	87
4.1.1	The weighted dual graph	87
4.1.4	The formula	88
4.1.9	Applications of the formula	89
4.2	Explicit computation of Tamagawa numbers	98
4.2.1	The quotient graph \tilde{G}	99
4.2.2	Explicit computation of Tamagawa numbers	99

Chapter 1

Introduction

Let R be a discrete valuation ring with fraction field K and residue field k . Let X be a nice (smooth, projective and geometrically integral) K -variety. The variety X is said to have good reduction if there exists a smooth and proper R -scheme \mathcal{X} whose generic fiber \mathcal{X}_K is isomorphic to X . In his 1967 paper [Ogg67], Ogg proved that an elliptic curve E (a nice group variety of dimension 1) defined over K has good reduction if and only if the natural action of the inertia group I_K on the ℓ -adic Tate module of E is trivial. This criterion (the *Néron–Ogg–Shafarevich criterion*) was later generalized by Serre and Tate [ST68] to abelian varieties of arbitrary dimension. The nontriviality of the inertia action on the Tate module of an abelian variety is captured by the nonvanishing of a certain numerical invariant, called (the exponent of) the conductor of the abelian variety (see Section 2.3 for the definition). For an abelian variety defined over a number field, the local conductors at various primes appear in the conjectured functional equation for the L -function of the abelian variety.

Elliptic curves occupy a special place in the study of nice varieties, since they straddle the worlds of algebraic curves (nice varieties of dimension 1) and abelian varieties (nice group varieties). One can ask if the Néron–Ogg–Shafarevich criterion extends to curves of arbitrary genus, with $H^1(X_{\overline{K}}, \mathbb{Q}_\ell)$ in place of the the ℓ -adic Tate module, but this turns out to be false [Oda95, Theorem 3.2]¹. The correct generalization of the conductor also takes into account the dimensions of the cohomology groups of the special fiber of the minimal proper

¹For an explicit example, see <http://mathoverflow.net/questions/91909/a-curve-with-bad-reduction-for-which-the-jacobian-has-good-reduction>.

regular model of the algebraic curve, and this is encoded in another numerical invariant called the Artin conductor (see Section 2.3 for the definition). For curves of genus $g \geq 2$, the Artin conductor vanishes exactly when the minimal proper regular model of the curve is smooth over R . For a nice curve defined over a number field, the Artin conductors at various primes appear in the conjectured functional equation for the L -function associated to a global proper regular model of X over the ring of integers of the number field [Blo87, Proposition 1.1]. The (negative of the) Artin conductor is an upper bound for the conductor of the I_K -representation $H^1(X_{\overline{K}}, \mathbb{Q}_\ell)$, and the difference of the two conductors is one less than the number of the components in the special fiber of the minimal proper regular model of X (Lemma 2.3.3).

Elliptic curves over K also have integral Weierstrass equations over R . An integral Weierstrass equation is an equation of the form

$$F(x, y, z) = y^2z + a_1xyz + a_3yz^2 + x^3 + a_2x^2z + a_4xz^2 + a_6z^3$$

that cuts out the elliptic curve in \mathbb{P}_K^2 , with $\{a_1, a_2, \dots, a_6\} \subset R$. Any such equation has an associated (valuation of) discriminant² [Sil09, p.42, Section III.1], which is a nonnegative integer that measures how far the corresponding closed subscheme of \mathbb{P}_R^2 is from being smooth over R . An integral Weierstrass equation that minimizes the value of the discriminant is called a minimal Weierstrass equation, and the corresponding discriminant is called the minimal discriminant. It can be shown that an elliptic curve over K has good reduction if and only if it has an integral Weierstrass equation with discriminant 0 (Proposition 2.1.5(c)).

Since elliptic curves have these two measures of failure of good reduction, namely the Artin conductor and the minimal discriminant, it is quite natural to ask how these two invariants are related. In [Ogg67], Ogg showed that the minimal discriminant of an elliptic curve over K equals the (negative) of the Artin conductor. He attributes this to a result of Tate from 1960 in the case when $\text{char } k \neq 2, 3$, and remarks that the results in his paper are

²For an elliptic curve over a global field, one can also define a global conductor and a global discriminant; our definitions of the discriminant and the conductor equal the valuation of the global discriminant and conductor; the definitions that we use are better suited to our situation since we are interested in studying the local behaviour at a *single* prime.

essentially about filling in the two remaining cases. However, the arguments in his paper fall short of handling the mixed characteristic 2 case, i.e., when $\text{char } K = 0$ and $\text{char } k = 2$. The gap in his proof was finally filled in 20 years later by Saito in [Sai88]. The proof given by Ogg proceeds by a lengthy case by case analysis, and uses the Kodaira-Néron classification of the possible special fibers of proper regular models of elliptic curves. Saito's result, on the other hand, is far more general, and holds for proper regular models of *arbitrary* curves, not just elliptic curves.

To describe Saito's result, we first need to recall some earlier results of Mumford and Deligne. For any integer $g \geq 1$, let $\overline{\mathcal{M}}_g$ be the Deligne-Mumford compactification of the moduli space of smooth genus g curves. In [Mum77, Theorem 5.10], Mumford established relations between certain natural classes of line bundles in $\text{Pic } \overline{\mathcal{M}}_g$. Deligne used one of Mumford's relations as a template for defining a discriminant for an arbitrary proper regular model \mathcal{X} over $\text{Spec } R$ (see Section 2.4 for the definition). Saito proved that the (negative of) the Artin conductor of a proper regular model \mathcal{X} equals the discriminant that Deligne defined. This new discriminant, which we call the Deligne discriminant, coincides with the minimal discriminant in the case when \mathcal{X} is the minimal proper regular model of an elliptic curve. In the case of genus 2 curves, Saito relates his result to an explicit formula given by Ueno for the Deligne discriminant when $\text{char } k = 0$ or when $\text{char } k > 6$. Ueno's formula is in terms of yet another notion of discriminant that is special to genus 2 curves, and it uses data pertaining to the geometry of the special fiber of a minimal proper regular model for a genus 2 curve [Uen88]. The explicit classification that Ueno used for special fibers of proper regular models of genus 2 curves already has over 120 different types! For higher genus curves, the Deligne discriminant is very hard to explicitly compute in practice.

For a genus g hyperelliptic curve, Liu defined a minimal discriminant that is analogous to the minimal discriminant for elliptic curves (see Section 2.1.3 for the definition). In [Liu94], Liu proved that for a genus 2 hyperelliptic curve, the minimal discriminant is an upper bound for the (negative of the) Artin conductor. For genus 2 curves, unlike elliptic curves, the minimal discriminant and the (negative of the) Artin conductor are sometimes different. In his paper, Liu gives an exact formula for the difference. When $\text{char } k \neq 2$, this difference can be computed quite explicitly in terms of the aforementioned classification

of fibers of genus 2 curves. When the hyperelliptic curve has semistable reduction over K , Kausz [Kau99] (when $\text{char } k \neq 2$) and Maugeais [Mau03] (for all residue characteristics) prove theorems that relate the Deligne discriminant to yet another discriminant. We are not sure if Liu's minimal discriminant coincides with the discriminant that is used by Kausz and Maugeais. One of the main results in this thesis is the following.

Theorem 1.0.1. *Let R be a discrete valuation ring with perfect residue field k . Assume that $\text{char } k \neq 2$. Let K be the fraction field of R . Let K^{sh} denote the fraction field of the strict henselization of R . Let C be a hyperelliptic curve over K of genus g . Let $\nu: K \rightarrow \mathbb{Z} \cup \{\infty\}$ be the discrete valuation on K . Assume that the Weierstrass points of C are K^{sh} -rational. Let $S = \text{Spec } R$ and let $\mathcal{X} \rightarrow S$ be the minimal proper regular model of C . Let $\nu(\Delta)$ denote the minimal discriminant of C . Then*

$$- \text{Art}(\mathcal{X}/S) \leq \nu(\Delta).$$

Our method of proof is different from Liu's method for genus 2 curves. Liu compares the Deligne discriminant of the minimal proper regular model and the minimal discriminant by comparing both of them to a third discriminant that he defines, following a definition given by Ueno [Liu94, Definition 1, Théorème 1 and Théorème 2]. This third discriminant is specific to genus 2 curves.

We instead proceed by constructing an explicit proper regular model for C (Section 3.1). We can immediately reduce to the case where R is a henselian discrete valuation ring with algebraically closed residue field. We may then choose a minimal Weierstrass equation of the form, $y^2 - f(x)$ where f is a monic polynomial in $R[x]$ that splits completely. If the Weierstrass points of C specialize to distinct points of the special fiber, then the polynomial $y^2 - f(x)$, suitably homogenized, defines a smooth proper model of C in a weighted projective space over R (see Section 2.1.3 for the definition). If not, we iteratively blow up \mathbb{P}_R^1 until the Weierstrass points have distinct specializations. After a few additional blow-ups, we take the normalization of the resulting scheme in the function field of C . This gives us a (not necessarily minimal) proper regular model for C (Theorem 3.1.4).

We have the relation $-\text{Art}(X/S) = n(X_s) - 1 + \tilde{f}$ for a proper regular model X of C ,

where $n(X_s)$ is the number of components of the special fiber of X and \tilde{f} is an integer that depends only on C and not on the particular proper regular model chosen. This tells us that to bound $-\text{Art}(X/S)$ for the minimal proper regular model from above, it suffices to bound $-\text{Art}(X/S)$ for some proper regular model for the curve.

In Section 3.2, we give an explicit formula for the Deligne discriminant for the model we have constructed. After a brief interlude on dual graphs in Section 3.3, we restate the formula for the Deligne discriminant using dual graphs. This formula tells us that the Deligne discriminant decomposes as a sum of terms, indexed by the vertices of the dual graph of the special fiber of the proper regular model we constructed (Section 3.4). In Section 3.5, we give a description of the rest of the strategy to prove the main theorem using this formula. The additional ingredients that are necessary are a decomposition of the minimal discriminant into a sum of terms depending on the local geometry of the graph (Section 3.6) and explicit formulae for the local terms in the Deligne discriminant in terms of dual graphs (Section 3.7). In Section 3.8, we show how to compare the Deligne discriminant and the minimal discriminant locally. To finish the proof, we sum the local inequalities to obtain $-\text{Art}(X/S) \leq \nu(\Delta)$.

One application of Theorem 1.0.1 is to give upper bounds on the number of components in the special fiber of the minimal proper regular model (Corollary 3.8.8). This has applications to Chabauty's method of finding rational points on curves of genus at least 2 [PS14].

It might be possible to adapt the same strategy to extend Theorem 1.0.1 to the case of nonrational Weierstrass points. The main difficulties in making this approach work are in understanding the right analogues of the results in Sections 3.6 and 3.7.

In the second half of this thesis, we study the component group scheme attached to the special fiber of the Néron model of a Jacobian. The Néron model of an abelian variety A defined over K is in a certain sense the best possible extension of A to a smooth, commutative group scheme \mathcal{A} over R (See Section 2.7 for a precise definition). The Néron model \mathcal{A} is proper over S if and only if the abelian variety has good reduction. In general, the special fiber of the Néron model might not be proper, or even connected. The special fiber of the

Néron model \mathcal{A}_s fits in an exact sequence

$$0 \rightarrow \mathcal{A}_s^0 \rightarrow \mathcal{A}_s \rightarrow \Phi \rightarrow 0,$$

where \mathcal{A}_s^0 is a connected group scheme and Φ is a finite étale group scheme, called the component group scheme. Let \bar{k} be an algebraic closure of k . The component group is $\Phi(\bar{k})$, and the Tamagawa number is the order of the group $\Phi(k)$.

Computing the orders of component groups and Tamagawa numbers have arithmetic applications. For an abelian variety A over a number field K , bounds on the order of the component group at a prime is one of the inputs for giving bounds on the order of the torsion subgroup of $A(K)$. Mazur used this fact in his paper [Maz77] to prove that for an elliptic curve E over \mathbb{Q} , the order of the torsion subgroup of $E(\mathbb{Q})$ is bounded above by 16. The local Tamagawa numbers appear in the statement of the full Birch and Swinnerton-Dyer conjecture; explicit verification of the full BSD conjecture for a specific abelian variety requires explicit computation of Tamagawa numbers.

In the special case where the abelian variety is the Jacobian J of a nice K -curve X , there are multiple approaches for constructing the Néron model. Under relatively mild hypotheses, one can construct the Néron model of J by using the theory of the relative Picard scheme of a proper regular model of X over $\text{Spec } R$ [BLR90, Chapter 9, Section 5, Theorem 4]. This method also leads to a description of the component group of the special fiber of the Néron model [BLR90, Chapter 9, Section 6, Theorem 1]: the component group is the middle homology group of a three term complex of free abelian groups, where the maps between the groups in the complex are given in terms of multiplicities and intersection numbers of the components in the special fiber of a proper regular model of $X \times K^{\text{sh}}$ (see Section 2.8 for details). The free abelian groups in this complex also admit natural actions of the absolute Galois group G of k that commute with the maps in the complex; Bosch and Liu used this action to give a description of $\Phi(k)$ similar to the description of the component group (Theorem 2.8.14), assuming that G is procyclic.

The multiplicities and the intersection numbers of components in the special fiber of a proper regular model can be encoded in a weighted graph, called the dual graph of the special

fiber (See Section 4.1.1 for the definition). In Theorem 4.1.5, we give an explicit formula for the order of the component group that can be expressed in terms of the combinatorics of this dual graph, using the matrix-tree theorem (2.6.2). Formulas of this type for the component group are not new, and special cases are well-known; when the proper regular model is semistable, the order of the component group equals the number of spanning trees in the dual graph, and when the dual graph is a tree, the order of the component group equals the product of the multiplicities of the components raised to certain exponents; each exponent depends on the number of neighbours of the corresponding vertex in the dual graph. The formula in Theorem 4.1.5 can be viewed as a hybrid of the formula in these two special cases, where each spanning tree in the dual graph is assigned a weight, and the expression for the weight is formally similar to the expression for the order of the component group in the case when the dual graph is a tree. A version of this formula is implicit in the proof of [Lor89, Corollary 3.5]. Using a weighted version of the matrix-tree theorem (Theorem 2.6.1), we obtain a similar formula for Tamagawa numbers expressed in terms of the combinatorics of a certain quotient graph.

For an elliptic curve having good or additive reduction the order of the component group is at most 4. Using our explicit formula in Theorem 4.1.5, we prove an analogue of this fact for curves of higher genus (Theorem 4.1.11). The condition of having good or additive reduction in genus 1 is replaced by a certain geometric condition on the -2 curves in the minimal proper regular model in higher genus. To explain the nature of this geometric condition, we first recall that any connected commutative algebraic group over a perfect field admits a three step filtration, where the quotients are an abelian variety, a torus, and a unipotent group. The dimensions of the corresponding groups for the special fiber \mathcal{A}_s^0 of the Néron model of any abelian variety, are called the abelian rank, toric rank and unipotent rank respectively. The condition of having good or additive reduction for an elliptic curve is equivalent to the elliptic curve having toric rank 0. When the abelian variety is a Jacobian, the unipotent, abelian and toric ranks can be computed from the geometry of the special fiber of a proper regular model of the curve [Lor90, p.148]. The toric rank equals the first Betti number of the dual graph of the special fiber of a proper regular model. In [Lor90], Lorenzini shows that there is a uniform bound on the order of component groups of Jacobians having toric

rank 0. The condition that we impose is strictly weaker than requiring that A have toric rank 0, since we only disallow cycles of -2 curves, and not cycles of curves where at least one of the curves in the cycle has geometric genus ≥ 1 .

Even though the order of the component group for a Jacobian is well-understood, the structure of the group remains quite mysterious. There are very few cases where the group structure is explicitly known; the only exceptions are genus 1 curves where one can use the Kodaira-Néron classification and a certain subset of Jacobians having potentially good reduction as described in [Lor92, Theorem 2.1]. We prove a periodicity property of the component group under partial contraction of connecting chains (Theorem 4.1.14), generalizing [BN07, Corollary 4.7] from the case of unweighted graphs.

The formation of the Néron model of an abelian variety does not commute with ramified base change: if (R', K') is a ramified extension of (R, K) , the Néron model of $A \times_K K'$ might not be equal to $\mathcal{A} \times_R R'$. The Néron component series defined by Halle and Nicaise (see Section 2.11 for the definition) simultaneously records the changes in the order of the component group under all tamely ramified extensions of the base in a power series. This power series is known to be rational in the following three cases: (i) when A acquires semistable reduction after a tame extension of the base, (ii) when the toric rank equals the dimension of A after a base extension, and (iii) when A is a Jacobian. It is believed to be rational in general. Using our explicit formula (Theorem 4.1.5), we provide an alternate proof of the key step in Halle and Nicaise's proof in case (iii), without having to resort to a reduction to the mixed characteristic case (Theorem 4.1.16).

Chapter 2

Background and Definitions

Let R be a henselian discrete valuation ring with algebraically closed residue field k . Let $p = \text{char } k \geq 0$. (The hypotheses on R and k hold for the rest of this thesis, unless explicitly stated otherwise.) Let K be the fraction field of R . Let \overline{K} denote a separable closure of K . Let $\nu: K \rightarrow \mathbb{Z} \cup \{\infty\}$ denote the discrete valuation on K . A K -variety is a separated scheme of finite type over K . A nice K -curve C is a smooth, projective, geometrically integral K -variety of dimension 1. Let $S = \text{Spec } R$. In this thesis, a hyperelliptic curve defined over K will be a nice positive-genus K -curve which admits a degree 2 map to \mathbb{P}^1 that is defined over K .

Remark 2.0.2. The most general definition for a hyperelliptic curve would be a nice K -curve X that admits a degree 2 map $X \rightarrow C$, where C is a nice genus 0 curve (that may or may not have rational points). However, we restrict our attention to those hyperelliptic curves for which C has a K -point.

2.1 Weierstrass models and minimal discriminants

Let A be a commutative ring. Let g be a positive integer ≥ 1 . Let $A[x, y, z]$ be the weighted polynomial ring over A which assigns weight 1 to the variables x and z , and weight $g+1$ to the variable y . Let $\mathbb{P}_A = \text{Proj } A[x, y, z]$. Given a polynomial $f(x, y) \in A[x, y]$, its homogenization $F(x, y, z)$ is given by $F(x, y, z) = z^{\deg f} f(x/z, y/z^{g+1})$, where $\deg f$ is the degree of f in the

weighted polynomial ring $A[x, y, z]$.

Definition 2.1.1. An integral Weierstrass equation for a hyperelliptic K -curve C of genus g is an equation $f(x, y) = y^2 + q(x)y - p(x) = 0$, where $q(x) \in R[x]$ is of degree $\leq g + 1$ and $p(x) \in R[x]$ is of degree $\leq 2g + 2$, such that the locus cut out by the homogenization of f in \mathbb{P}_K is isomorphic to C .

Let $A = \mathbb{Z}[p_0, p_1, \dots, p_{2g+2}, q_0, q_1, \dots, q_{g+1}]$ and let $B = \text{Spec } A$. Let $P(x, z) = \sum_{i=0}^{2g+2} p_i x^i z^{2g+2-i}$ and let $Q(x, z) = \sum_{i=0}^{g+1} q_i x^i z^{g+1-i}$. Let $F(x, y, z) = y^2 + Q(x, z)y - P(x, z)$. The universal family of hyperelliptic curves in Weierstrass form $\pi: \mathcal{W} \rightarrow B$ is the hypersurface cut out by F in \mathbb{P}_A . Standard arguments show that the image (under π) of the non-smooth locus of π is a closed irreducible hypersurface in B , and hence is cut out by a single polynomial $\Delta \in A$, determined uniquely up to sign. Over $B \times_{\mathbb{Z}} \mathbb{Z}[1/2]$, this hypersurface is the vanishing locus of the polynomial $\Delta' := \text{disc}(4P(x, z) + Q(x, z)^2)$. Hence $\Delta = u\Delta'$ for some unit u in $A[1/2]$, i.e., $u = 2^a$ for some $a \in \mathbb{Z}$. To compute a , we can use the fact Δ is a 2-adic unit when evaluated at any hyperelliptic curve over \mathbb{Z} that has good reduction at 2 (for example, the hyperelliptic curve given by $y^2 + z^{g+1}y = x^{2g+1}z$); this yields $a = -4(g + 1)$.

Definition 2.1.2. The discriminant of the hyperelliptic equation $f(x, y) = y^2 + q(x)y - p(x) = 0$ equals $\nu(\Delta(f))$, where $\Delta(f)$ equals Δ evaluated at the coefficients of the homogenization of f .

Definition 2.1.3. [Liu96, Definition 3, Remarque 4] A minimal Weierstrass equation for a hyperelliptic K -curve C is an integral Weierstrass equation for C whose discriminant is minimal amongst all integral Weierstrass equations of C . The discriminant of a minimal Weierstrass equation is called the minimal discriminant.

Proposition 2.1.4. *Let C be a hyperelliptic K -curve of genus g .*

- (a) *The curve C has an integral Weierstrass equation.*
- (b) *If the degree 2 morphism $C \rightarrow \mathbb{P}_K^1$ has a K -rational branch point, then we can find a minimal Weierstrass equation of the form $y^2 + q(x)y = p(x)$, where $\deg q \leq g$ and $\deg p \leq 2g + 1$.*

(c) If $\text{char } k \neq 2$, the curve C has a minimal Weierstrass equation of the form $y^2 = p(x)$.

Proof.

(a) We first prove that there exists an integral Weierstrass equation for C . Let $\pi: C \rightarrow \mathbb{P}_K^1$ be the canonical morphism. Let $D = \pi^*((\infty))$. Using the Riemann-Roch theorem and the fact that C is hyperelliptic, we can pick elements $x, y \in K(C)$ such that $\{1, x\}$ is a basis for $H^0(C, D)$ and $\{1, x, \dots, x^{g+1}, y\}$ is a basis for $H^0(C, (g+1)D)$. Since

- $\{1, x, \dots, x^{2g+1}, y, yx, \dots, yx^g\}$ is a basis for $H^0(C, (2g+1)D)$,
- $\{1, x, \dots, x^{2g+2}, y, yx, \dots, yx^{g+1}, y^2\}$ span $H^0(C, (2g+2)D)$,
- $\dim H^0(C, (2g+2)D) = 3g+5$, and,
- $y \notin K(x) \cap H^0(C, (g+1)D)$,

there has to be a nontrivial relation

$$y^2 + (b_0x^{g+1} + b_1x^g + \dots + b_{g+1})y = a_0x^{2g+2} + a_1x^{2g+1} + \dots + a_{2g+2}$$

for some set $\{b_0, b_1, \dots, b_{g+1}, a_0, a_1, a_{2g+2}\} \subset K$. Replacing x by ux replaces b_0 by $u^{g+1}b_0$ and a_0 by $u^{2g+2}a_0$, so by making u sufficiently divisible by the uniformizer, we get a nontrivial relation where $b_0, a_0 \in R$. Now if we simultaneously replace x by $u^{-1}x$ and y by $u^{-(g+1)}y$, we get a relation where each b_i is replaced by $u^i b_i$ and each a_i is replaced by $u^i a_i$. By making u sufficiently divisible by the uniformizer of R , we can make all the b_i and all the a_i integral. Let C' be the K -curve defined by the corresponding weighted homogeneous equation. The complete linear system $H^0(C, (2g+2)D)$ induces a rational map $C \dashrightarrow C'$ that factors via the normalization $\overline{C'}$ of C' . The curve C' has arithmetic genus $g(C)$. Therefore the genus of $\overline{C'}$ is less than or equal to $g(C)$, and equality holds only when C' is smooth. Since C and $\overline{C'}$ are both smooth, projective curves, the rational map $C \dashrightarrow \overline{C'}$ is in fact a morphism. Since there are no morphisms from C to a curve of strictly smaller genus, it follows from the Riemann-Hurwitz formula that C' is smooth, and the morphism $C \rightarrow C'$ is an isomorphism. This gives us an integral Weierstrass equation.

- (b) Start with a minimal Weierstrass equation $y^2 + Q(x, z)y = P(x, z)$. Since $\mathrm{PGL}_2(R)$ acts transitively on $\mathbb{P}^1(K)$, we first make an R -linear change of variables that sends $\pi(P)$ to ∞ (i.e., the point with homogeneous $(x : z)$ coordinates $[1 : 0]$). Then we make the change of coordinates $y \mapsto y + \sqrt{p_{2g+2}}x^{g+1}$. These two operations gives us a new Weierstrass equation, which we continue to denote by $y^2 + Q(x, z)y = P(x, z)$. The new equation has the same discriminant as the original Weierstrass equation, and therefore is also minimal. By our choice of change of coordinates, it follows that $p_{2g+2} = 0$. Since P is a Weierstrass point, the quadratic equation $y^2 + q_{g+1}y = y^2 + Q(1, 0)y - P(1, 0) = 0$ has a unique solution, which implies that $q_{g+1} = 0$. This proves (c).
- (c) If $\mathrm{char} k \neq 2$, and $y^2 - q(x)y = p(x)$ is a minimal Weierstrass equation for C , one can check that $y^2 = (y - \frac{q(x)}{2})^2 = 4^{-1}(4p(x) + q(x)^2)$ is also a minimal Weierstrass equation for C . This proves (d). \square

Proposition 2.1.5. *A hyperelliptic K -curve C has good reduction if and only if its minimal discriminant is 0.*

Proof. If C has a minimal Weierstrass equation with discriminant 0, then the subscheme defined by the corresponding homogenized equation in \mathbb{P}_R is smooth and proper over S and has generic fiber C . This proves one direction of the implication.

For the other direction, let \mathcal{C} be a smooth, proper S -scheme with generic fiber C . Let $\pi: \mathcal{C} \rightarrow \mathbb{P}_K^1$ be the canonical morphism. Let $D = \pi^*((\infty))$ and let \overline{D} denote the flat closure of D in \mathcal{C} . We repeat the argument in Theorem 2.1.4(a) with \overline{D} in place of D . We have to be slightly careful, since the global sections of multiples of \overline{D} are now R -modules, and not K -vector spaces. However, all the R -modules involved are free — they are torsion-free from being subsheaves of the function field of C , and are free since R is a discrete valuation ring. So all the arguments in Theorem 2.1.4[(a)] go through, as long as we carefully choose free R -module generators in place of K -bases. The relation $y^2 + q(x)y = p(x)$ that we obtain can be used to define a closed subscheme \mathcal{C}' of \mathbb{P}_R . By our choice of module generators, the special fiber \mathcal{C}'_s is isomorphic to \mathcal{C}_s and is therefore smooth over $\mathrm{Spec} k$. By the definition of Δ , its image in k must be nonzero when evaluated at the coefficients of the defining equation for \mathcal{C}'_s . Therefore the discriminant of the corresponding Weierstrass equation must be 0. \square

2.2 Regular models

Definition 2.2.1. A regular model for a nice curve C is a proper, flat, regular S -scheme X , whose generic fiber is isomorphic to C . A regular S -curve X is an S -scheme that is a regular model for its generic fiber.

For a regular S -curve X , let $X_s := X \times_R k$ denote its special fiber, let $X_\eta := X \times_R K$ denote its generic fiber and let $X_{\bar{\eta}} := X \times_R \bar{K}$ denote its geometric generic fiber. For a scheme X , let X_{red} denote the associated reduced subscheme.

Definition 2.2.2. A regular model X is a simple normal crossings (snc) model if the irreducible components of $(X_s)_{\text{red}}$ are smooth, and $(X_s)_{\text{red}}$ has at worst nodal singularities.

Let C be a nice K -curve of genus $g \geq 1$. Given any two regular models X' and X of C , the identity map $C \rightarrow C$ can be viewed as a rational map $X' \dashrightarrow X$.

Definition 2.2.3. The minimal proper regular model of C is a regular model such that for every regular model X' , the rational map $X' \dashrightarrow X$ is a morphism.

The minimal proper regular model of C exists and is unique up to unique isomorphism; any other regular model can be obtained from the minimal proper regular model by a sequence of blow-ups [Lic68, Theorem 4.4].

2.3 Artin conductor

Let $G := \text{Gal}(\bar{K}/K)$ be the absolute Galois group of K . Equip G with the profinite topology. The group G admits a filtration $G = G_0 \supset G_1 \supset G_2 \supset \dots$ where G_1 is the maximal pro- p subgroup of G , called the *wild inertia* subgroup and G_i is the i^{th} *ramification subgroup* (in the lower numbering). Fix a prime $\ell \neq p$. Let $\rho: G \rightarrow \text{Aut}(V)$ be a continuous finite dimensional \mathbb{Q}_ℓ -representation of G , where $\text{Aut}(V)$ has the ℓ -adic topology. For $\sigma \in G$, let $\text{Tr}(\rho(\sigma))$ denote the trace of $\rho(\sigma)$. The restriction of ρ to G_1 factors via a finite quotient $q: G_1 \rightarrow G'_1$ (essentially because every continuous homomorphism from a pro- p group to a pro- ℓ group is trivial). Let $L \supset K$ be a finite Galois extension such that $G_1 \cap \text{Gal}(\bar{K}/L)$ acts

trivially on V . Then L is also a discretely valued field; let π be a generator for the maximal ideal of the ring of integers of L and let $\nu_L: L \rightarrow \mathbb{Z} \cup \{\infty\}$ be the associated discrete valuation. Define a function $\text{sw}_{L/K}: \text{Gal}(L/K) \rightarrow \mathbb{Z}$ as follows (see [KS04, Section 6.1] for details):

$$\text{sw}_{L/K}(\sigma) := \begin{cases} 1 - \nu_L(\sigma(\pi) - \pi) & \text{if } \sigma \neq 1 \\ \sum_{\tau \neq 1} (\nu_L(\tau(\pi) - \pi) - 1) & \text{if } \sigma = 1. \end{cases}$$

Let $P = G_1/(G_1 \cap \text{Gal}(\overline{K}/L))$. For any subspace $W \subset V$, let $\text{codim } W$ denote the codimension of W in V . For any $i \geq 0$, let V^{G_i} denote the subspace of V consisting of elements fixed pointwise by every element of G_i . The definition of the Swan conductor below is independent of the choice of L by [KS04, Lemma 6.1.1.1]. The tame conductor ϵ of the representation V is defined by

$$\epsilon = \text{codim } V^G,$$

and the Swan conductor δ of V is defined by

$$\delta = \frac{1}{[L:K]} \sum_{\sigma \in P} \text{sw}_{L/K}(\sigma) \text{Tr}(\rho(\sigma)).$$

The conductor f of the representation V is given by

$$f = \epsilon + \delta.$$

For a finite set S , let $|S|$ denote the cardinality of S .

Remark 2.3.1. [Ser, Section 19.3] If the image of G under ρ is finite, then

$$\delta = \sum_{i \geq 1} \frac{|\rho(G_i)|}{|\rho(G_0)|} \text{codim } V^{G_i}.$$

Let X be a regular S -curve. Fix $\ell \neq p$. For any curve C over an algebraically closed field

of char $\neq \ell$, the ℓ -adic Euler-Poincaré characteristic $\chi(C)$ of C is given by

$$\chi(C) = \sum_{i=0}^2 (-1)^i \dim H_{\text{ét}}^i(C, \mathbb{Q}_\ell).$$

Since X_η is defined over K , the group G acts on $H_{\text{ét}}^1(X_\eta, \mathbb{Q}_\ell)$ by functoriality. Let δ be the Swan conductor of this representation.

Definition 2.3.2. The Artin conductor $\text{Art}(X)$ of the regular model X is defined by

$$- \text{Art}(X) = \chi(X_s) - \chi(X_\eta) + \delta.$$

Lemma 2.3.3. [Liu94, Proposition 1] *Let f be the conductor of the G -representation $H_{\text{ét}}^1(X_\eta, \mathbb{Q}_\ell)$. Let $n(X_s)$ be the number of irreducible components of the special fiber of X_s . Then*

$$- \text{Art}(X/S) = n(X_s) - 1 + f.$$

Definition 2.3.4. Let C be a nice curve of genus $g \geq 1$ and let X be its minimal proper regular model. The Artin conductor $\text{Art}(C)$ of C is defined to be $\text{Art}(X)$.

2.4 Deligne discriminant

In [Mum77, Theorem 5.10], Mumford established various relations amongst line bundles on the coarse moduli space \mathcal{M}_g of smooth curves of genus g (in fact, he even proved an extension of these relations to the Deligne-Mumford compactification $\overline{\mathcal{M}}_g$). Pulling back one of Mumford's relations along an arbitrary morphism $T \rightarrow \mathcal{M}_g$ gives rise¹ to the following proposition.

Theorem 2.4.1. [Del85, Proposition] *Let $f: Y \rightarrow T$ be a proper smooth morphism over an arbitrary base T , all of whose fibers are nice curves. Let $\omega_{Y/T}$ denote the relative dualizing*

¹What we actually need is a similar relation on the moduli stack, and this is proved in an unpublished letter of Deligne [Del85, Proposition]. In his letter, Deligne comments that this makes a difference only in genus ≤ 2 , since the Picard group of the moduli stack has no torsion when $g \geq 3$.

sheaf of the morphism f . Then there exists a canonical isomorphism (unique up to sign) of sheaves

$$\Delta: \det(Rf_*(\omega_{Y/T}^{\otimes 2})) \rightarrow \det(Rf_*\omega_{Y/T})^{\otimes 13}.$$

Using the above proposition, we can attach an integer discriminant to an arbitrary regular S -curve as follows. Let X be a regular S -curve, and let $\omega_{X/S}$ be the relative dualizing sheaf of $f: X \rightarrow S$. The canonical isomorphism in Theorem 2.4.1 gives rise to a canonical nonzero rational section $\Delta = \Delta_{X/S}$ of the invertible \mathcal{O}_S -module (equivalently R -module)

$$\mathrm{Hom}_{\mathcal{O}_S}(\det(Rf_*(\omega_{X/S}^{\otimes 2})), \det(Rf_*\omega_{X/S})^{\otimes 13}).$$

Given an invertible \mathcal{O}_S -module M and a rational section $m \in M \otimes_R K$, the order of vanishing of m is the unique integer s such that $Rm = \pi^s M$, where π is a uniformizer of R .

Definition 2.4.2. The Deligne discriminant $\mathrm{ord} \Delta_X$ of X/S is the order of vanishing of the canonical rational section Δ of $\mathrm{Hom}_{\mathcal{O}_S}(\det(Rf_*(\omega_{X/S}^{\otimes 2})), \det(Rf_*\omega_{X/S})^{\otimes 13})$.

2.5 Relation between the Deligne discriminant and the Artin conductor

Theorem 2.5.1. [Sai88, Theorem 1] *Let X be a regular S -curve. Then*

$$- \mathrm{Art}(X/S) = \mathrm{ord} \Delta_X.$$

2.6 Some graph theory

A directed weighted multigraph G is a quadruple $(V(G), \vec{E}(G), p, w)$, where

- $V(G)$ is a finite set called the vertices of G ,
- $\vec{E}(G)$ is a finite set called the directed edges of G ,
- $p: \vec{E}(G) \rightarrow V(G) \times V(G)$ is a map of sets, and,

- $w: \overrightarrow{E}(G) \rightarrow \mathbb{N}$ is a nonnegative integer valued function called the weight function.

For $e \in \overrightarrow{E}(G)$, define the head e^+ and the tail e^- by $(e^-, e^+) = p(e)$. Let $a, b \in V(G)$. A directed path in G from a to b is an ordered set of vertices $\{v_0, \dots, v_k\}$ and an ordered set of directed edges e_1, \dots, e_k such that $v_0 = a, v_k = b$ and $e_i^- = v_{i-1}, e_i^+ = v_i$ for all $i \in [1, k]$. If $v \in V(G)$, we will also use v to denote the corresponding basis element of $\mathbb{Z}^{V(G)}$. Let $v \in V(G)$. A spanning tree directed into v is a directed weighted multigraph $T = (V(T), \overrightarrow{E}(T), p', w')$ such that

- $V(T) = V(G)$,
- $\overrightarrow{E}(T) \subset \overrightarrow{E}(G)$, and $p'(e) = p(e), w'(e) = w(e)$ for every $e \in \overrightarrow{E}(T)$, and,
- for every $u \in V(T)$, there is a unique directed path in T from u to v .

The weight of a spanning tree equals the product of the weights of all the directed edges in the spanning tree. The vertex v is called a sink if there is a directed path in G from u to v for every vertex $u \in V(G)$. Assume that v is a sink, let $W = V(G) - \{v\}$ and let $\Delta_{\text{red}}: \mathbb{Z}^W \rightarrow \mathbb{Z}^W$ be the linear map defined by

$$u \mapsto \left(\sum_{\substack{e \in \overrightarrow{E}(G) \\ e^- = u}} w(e) \right) u - \sum_{t \in W} \left(\sum_{\substack{e \in \overrightarrow{E}(G) \\ e^+ = t, e^- = u}} w(e) \right) t$$

for every $u \in W$. The map Δ_{red} is called the reduced Laplacian of G with respect to the sink v .

We recall the statement of the Matrix-Tree theorem for directed weighted multigraphs.

Theorem 2.6.1. [PPW13, Theorem 2.5] *The determinant of the reduced Laplacian of G is equal to the sum of the weights of all its directed spanning trees into the sink.*

For any set V , the symmetric group on two letters S_2 acts on $V \times V$ by interchanging the two factors, and we denote by $\pi_V: V \times V \rightarrow (V \times V)/S_2$ the corresponding map from $V \times V$ to the space of orbits of $V \times V$ under this action. A graph is a quadruple $(V(G), E(G), p, w)$, where

- $V(G)$ is a finite set, called the set of vertices of G ,
- $E(G)$ is a finite set, called the set of edges of G ,
- $p: E(G) \rightarrow (V(G) \times V(G))/S_2$ is a map of sets, and,
- $w: E(G) \rightarrow \mathbb{N}$ is a nonnegative integer valued function called the weight function.

Given a graph $G = (V, E, p, w)$, we define the associated unweighted graph to be the triple (V, E, p) . Every graph $G = (V, E, p, w)$ also has an associated directed weighted multigraph $\vec{G} = (\vec{V}, \vec{E}, \vec{p}, \vec{w})$ uniquely characterized (up to isomorphism) by the following properties:

- $\vec{V} = V$,
- there exists a map $\tilde{\pi}: \vec{E} \rightarrow E$ such that the following diagrams commute

$$\begin{array}{ccc}
 \vec{E} & \xrightarrow{\vec{p}} & V \times V \\
 \downarrow \tilde{\pi} & & \downarrow \pi_V \\
 E & \xrightarrow{p} & (V \times V)/S_2
 \end{array}
 \qquad
 \begin{array}{ccc}
 \vec{E} & \xrightarrow{\vec{w}} & \mathbb{N} \\
 \downarrow \tilde{\pi} & & \downarrow \text{Id}_{\mathbb{N}} \\
 E & \xrightarrow{w} & \mathbb{N}
 \end{array}$$

- $\#\tilde{\pi}^{-1}(e) = 2$ for every $e \in E$, and,
- if $\tilde{\pi}^{-1}(e) = \{e_1, e_2\}$, then $e_1^- = e_2^+$ and $e_1^+ = e_2^-$.

The set of endpoints of an edge e , denoted $D(e)$, is the set $\{e_1^+, e_1^-\}$ for any $e_1 \in \tilde{\pi}^{-1}(e)$ (this set is well-defined by the last condition listed above). A subgraph of a graph $G = (V(G), E(G), p, w_G)$ is a graph $H = (V(H), E(H), p_H, w_H)$ such that $V(H) \subset V(G)$, $E(H) \subset E(G)$, $p_H = p|_{E(H)}$ and $w_G|_{E(H)} = w_H$. A spanning tree T of a graph G is a subgraph of G such that $V(T) = V(G)$, and $E(T) = \tilde{\pi}(\vec{E}(T'))$, where T' is a spanning tree directed into some vertex v for the associated directed weighted multigraph \vec{G} . For a graph G , let $S(G)$ denote the set of spanning trees of G . For a vertex v in a graph G , let $N_G(v)$ denote the set of neighbours of v in G , that is, the set of vertices v' such that there exists an edge $e \in E(G)$

whose set of endpoints $D(e)$ equals $\{v, v'\}$. Let $\Delta: \mathbb{Z}^{V(G)} \rightarrow \mathbb{Z}^{V(G)}$ be the linear map defined by

$$u \mapsto \left(\sum_{e \in E(G), u \in D(e)} w(e)u - \sum_{t \in V(G)} \left(\sum_{e \in E(G), D(e) = \{t, u\}} w(e) \right) t \right)$$

for every $u \in V(G)$. Let L denote the matrix of Δ with respect to the standard basis of $\mathbb{Z}^{V(G)}$. The map Δ is called the Laplacian of G . For a vertex $v \in V(G)$, let L_v denote the absolute value of the minor of the element L_{vv} of L . We recall the statement of the Matrix-Tree theorem for graphs.

Theorem 2.6.2. [CS97, Theorem 1] *For any vertex v , the number L_v equals the sum of the weights of all the spanning trees of the graph G .*

A subgraph C of a graph G is called a cycle if $\#V(C) = \#E(C) \geq 1$ and if there exists an ordering (v_1, v_2, \dots, v_k) of $V(C)$, and an ordering (e_1, e_2, \dots, e_k) of $E(C)$ such that $D(e_i) = \{v_i, v_{i+1}\}$ if $1 \leq i < k$ and $D(e_k) = \{v_1, v_k\}$. We say that a vertex v belongs to a cycle C if $v \in V(C)$; similarly, we say that an edge e belongs to a cycle C if $e \in E(C)$. A subgraph C of a graph G is called a chain if $\#V(C) = \#E(C) + 1 \geq 1$ and if there exists an ordering $(v_0, v_1, v_2, \dots, v_k)$ of $V(C)$, and an ordering (e_1, e_2, \dots, e_k) of $E(C)$ such that $D(e_i) = \{v_{i-1}, v_i\}$ for all i ; the length of the chain is k . An edge e in a graph G is called a connecting edge if there exists a partition $\{V_1, V_2\}$ of the set $V(G)$ such that the only edge with one endpoint in V_1 and another endpoint in V_2 is e . A connecting chain is a chain C such that every edge of C is a connecting edge. Contracting a connecting chain C in a graph $G = (V, E, p, w)$ gives rise to another graph $G' = (V', E', p', w')$ defined as follows. Let \sim be the equivalence relation on V that identifies all the vertices in $V(C)$, and let V/\sim denote the equivalence classes. Let $V' := V/\sim$, let $E' := E - E(C)$, let $w' = w|_{E'}$ and let p' be the composition of p with the natural quotient map from $(V \times V)/S_2$ to $(V' \times V')/S_2$.

Let v, w be two distinct vertices in an unweighted graph $G = (V, E, p)$ and let $[v, w]$ denote the corresponding class in $(V \times V)/S_2$. Let $\alpha_{v,w} := \#p^{-1}([v, w])$. Let $\beta: \mathbb{Z}^V \rightarrow \mathbb{Z}$ be a linear map such that for every $v \in V$, we have that $\beta(v)$ divides $\sum_{w \in V, w \neq v} \beta(w)\alpha_{v,w}$. We call such a pair (G, β) a graph equipped with a multiplicity function. For every $v \in V$, let $\alpha_{v,v}$ be the unique integer defined by the relation $\sum_{w \in V} \beta(w)\alpha_{v,w} = 0$. Let $\alpha: \mathbb{Z}^V \rightarrow \mathbb{Z}^V$ denote

the linear map corresponding to the matrix $(\alpha_{v,w})$. Then by the definition of α , we have $\text{im } \alpha \subset \ker \beta$. The component group $\Phi(G)$ of the pair (G, β) is defined by $\Phi(G) := \ker \beta / \text{im } \alpha$.

Lemma 2.6.3. *Suppose that (G, β) is a graph equipped with a multiplicity function, and suppose that C is a connecting chain in G such that $\beta|_{V(C)}$ is constant. Let $G' = (V', E', p')$ be the contraction of C in G . Define $\beta': \mathbb{Z}^{V'} \rightarrow \mathbb{Z}$ so that the composition $\mathbb{Z}^V \rightarrow \mathbb{Z}^{V'} \xrightarrow{\beta'} \mathbb{Z}$ is β . Then (G', β') is a graph equipped with a multiplicity function, and gives rise to a component group $\Phi(G')$.*

Proof. For a pair of distinct vertices v', w' in $V(G')$, let $\alpha'_{v',w'} = \#p'^{-1}([v', w'])$. Choose an ordering (v_0, v_1, \dots, v_k) of $V(C)$ as in the definition of a connecting chain, and let v' denote the common image of these vertices in $V(G')$. Since $\sum_{w \in V} \beta(w) \alpha_{v_0,w} = 0$ and $\sum_{w \in V} \beta(w) \alpha_{v_k,w} = 0$, adding these together tells us that $\beta'(v')$ divides $\sum_{w' \neq v'} \beta'(w') \alpha'_{v',w'}$. This finishes the proof. \square

2.7 Néron models

In this section, we relax the hypothesis and let R be any discrete valuation ring with perfect residue field. Let K be the fraction field of R . Let $S = \text{Spec } R$. Let \mathcal{A} be the Néron model of an abelian variety A defined over K . It is characterized by the following universal property: it is the unique smooth S -group scheme such that for every smooth S -scheme T , we have a natural isomorphism $\mathcal{A}(T) \simeq A(T \times_S K)$ that is functorial in T . Much of the book [BLR90] is devoted to the construction of the Néron model.

The Néron model \mathcal{A} is proper over S if and only if the abelian variety A has good reduction. In general, the special fiber of \mathcal{A}_k might not be proper, or even connected. The special fiber \mathcal{A}_s fits in the following exact sequence

$$0 \rightarrow \mathcal{A}_s^0 \rightarrow \mathcal{A}_s \rightarrow \Phi \rightarrow 0,$$

where \mathcal{A}_s^0 is a connected group scheme and Φ is a finite étale group scheme, called the component group scheme. The component group is the set of points of the component group scheme over an algebraic closure, and the Tamagawa number is the order of the group $\Phi(k)$.

The connected group scheme \mathcal{A}_s^0 has a Chevalley decomposition:

$$0 \rightarrow U \times T \rightarrow \mathcal{A}_s^0 \rightarrow B \rightarrow 0.$$

In the exact sequence above, U is a unipotent algebraic group, T is a torus and B is an abelian variety. The dimensions of these groups are called the unipotent rank, toric rank and abelian rank respectively.

2.8 Component groups and Tamagawa numbers of Jacobians

2.8.1 The Artin–Winters type of a regular S -curve

Let X be a regular S -curve. Let $X_s = \sum_{i \in I} r_i E_i$. Here the E_i are the (reduced) irreducible components of X_s and r_i is the multiplicity of E_i in X_s for every $i \in I$. Let K be a relative canonical divisor for $X \rightarrow S$.

Definition 2.8.2. [AW71, Definition 1.2] The type T of X consists of the integers

$$\#I; (E_i \cdot E_j); (E_i \cdot K); r_i \quad \text{for all } i, j \in I.$$

The genus g of X_η satisfies $2g - 2 = X_s \cdot K = \sum_{i \in I} r_i E_i \cdot K$.

Definition 2.8.3. A collection of integers

$$n; m_{ij}; k_i; r_i \quad i, j = 1, \dots, n$$

is called a type if

- $n \geq 1$,
- $r_i \geq 1$ for every i ,
- $m_{ij} = m_{ji} \geq 0$ if $i \neq j$, and for every i , we have $\sum_j r_j m_{ij} = 0$, and,

- for every i , we have $m_{ii} + k_i \in \{-2, 0, 2, 4, \dots\}$.

Definition 2.8.4. The genus of a type T equals $1 + \frac{1}{2} \sum r_i k_i$.

Definition 2.8.5. An exceptional curve in a type T is an index i such that $k_i = -1$ and $m_{ii} = -1$.

Let T be a type containing three indices, say $i = 1, 2, n$ having the following properties:

$$\begin{aligned} r_1 &= r_2 = r_n \\ k_n &= 0 \\ m_{ni} &= \begin{cases} 1 & \text{if } i = 1, 2 \\ -2 & \text{if } i = n \\ 0 & \text{if } i \notin \{1, 2, n\}. \end{cases} \end{aligned}$$

The contraction of n in the type T is the new type T' obtained by omitting the index n , increasing m_{12} and m_{21} by 1, and leaving all the other data unchanged (one can easily check that T' is a type, i.e., it satisfies the conditions above). Conversely, given the type T' , we can build a new type T by reversing the process above; we say that the type T is a decontraction of T' .

Definition 2.8.6. Two types T_1 and T_2 are similar if one can be obtained from the other by a series of contractions and decontractions.

Theorem 2.8.7. [AW71, Theorem 1.6] *Let $g \geq 2$ be an integer. There are finitely many similarity classes of types T of genus g without exceptional curves.*

Theorem 2.8.8. [Win74, Corollary 4.3] *Let $T = (n; m_{ij}; k_i; r_i)$ be a type. Let k be an algebraically closed field. Assume that $\text{char } k$ does not divide any r_i . Then there exists a proper map $f: X \rightarrow Y$ from a nice k -surface onto a nice k -curve with a closed fiber $Z = \sum_{i=1}^n r_i E_i$ having this type, having nonsingular components E_i having normal crossings.*

2.8.9 Component groups

The description of the component group given in [BLR90, Section 9.6] holds in generality slightly greater than what we assume later in this thesis. In this section, we state the more general results. We relax the assumption on R and assume that it is a strictly henselian discrete valuation ring (which implies only that the residue field k is separably closed, and not necessarily algebraically closed). Let X be a proper, flat, regular curve over S whose generic fiber is geometrically irreducible. Let \bar{k} be an algebraic closure of the residue field k of R . Let $(X_i)_{i \in I}$ be the (reduced) irreducible components of X_k . For each $i \in I$, let η_i be the generic point corresponding to X_i . Let $\overline{X_k} := X_k \times_k \bar{k}$ and let $\overline{X_i} := X_i \times_k \bar{k}$. For each i , let $\overline{\eta_i} \in \overline{X_k}$ be the unique point lying over η_i .

Definition 2.8.10. The multiplicity d_i of X_i in X_k is the length of the Artinian local ring $\mathcal{O}_{X_k, \eta_i}$. The geometric multiplicity δ_i of X_i in X_k is the length of the Artinian local ring $\mathcal{O}_{\overline{X_k}, \overline{\eta_i}}$. The geometric multiplicity e_i of X_i is the length of the Artinian local ring $\mathcal{O}_{\overline{X_i}, \overline{\eta_i}}$.

If k is algebraically closed, then $e_i = 1$ for all $i \in I$.

Let J be the Jacobian of X_K and let \mathcal{J} be its Néron model.

Theorem 2.8.11. [BLR90, Section 9.6, Theorem 1] *Assume either that k is algebraically closed, or that X admits a section. Consider the homomorphisms*

$$\mathbb{Z}^I \xrightarrow{\alpha} \mathbb{Z}^I \xrightarrow{\beta} \mathbb{Z},$$

where α is given by the modified intersection matrix $(e_i^{-1} X_i \cdot X_j)_{i, j \in I}$ and $\beta((a_i)_{i \in I}) := \sum a_i \delta_i$. Then $\text{im } \alpha \subset \ker \beta$. The component group of \mathcal{J}_s is canonically isomorphic to the quotient $\ker \beta / \text{im } \alpha$.

Corollary 2.8.12. [BLR90, Section 9.6, Corollary 4] *Assume that all the e_i are equal to 1. Let $\#I = r$ and let $d = \gcd(d_i : i \in I)$. Let M be the $r \times r$ matrix corresponding to the intersection pairing, i.e., the matrix with entries $(X_i \cdot X_j)_{i, j \in I}$. Fix i and j . Let a_{ij}^* be the $(r-1) \times (r-1)$ minor corresponding to the index (i, j) . Then*

$$\#\Phi(\bar{k}) = \frac{d^2}{d_i d_j} a_{ij}^*.$$

2.8.13 Tamagawa numbers

In this section, we do not assume that the residue field k is separably closed. Assume that k is perfect and let \bar{k} denote an algebraic closure of k . Let R^{st} denote the strict henselization of R . Let X be a regular S -curve. Let Φ denote the component group scheme of the Néron model of the Jacobian of X_K . The main objective of this section is to recall the description of $\Phi(k)$ given by Bosch and Liu in [BL99].

Let $X^{\text{st}} = X \times_R R^{\text{st}}$. Let V denote the set of (reduced) irreducible components of X_s^{st} , and let \tilde{V} denote the set of (reduced) irreducible components of X_s . The set \tilde{V} can also naturally be identified with the space of orbits for the natural action of $\text{Gal}(\bar{k}/k)$ on V . This gives rise to a quotient map $\pi: V \rightarrow \tilde{V}$, where we map $v \in V$ to the corresponding orbit. For every $\tilde{v} \in \tilde{V}$, let $|\tilde{v}|$ denote the size of the orbit corresponding to \tilde{v} and let $m_{\tilde{v}}$ denote the multiplicity of \tilde{v} in X_s . Let m_v denote the multiplicity of v in X_s^{st} . Consider the complex

$$\mathbb{Z}^{\tilde{V}} \xrightarrow{\alpha} \mathbb{Z}^{\tilde{V}} \xrightarrow{\beta} \mathbb{Z},$$

where the maps α and β are defined as follows.

For any $v, w \in V$, let $v.w$ denote the intersection number of the components v and w in X_s^{st} . In order to define α , we need to fix some $w \in \pi^{-1}(\tilde{w})$ for every $\tilde{w} \in \tilde{V}$. The map below is well-defined, independent of this choice, since the Galois action permutes the various $w \in \pi^{-1}(\tilde{w})$ and preserves intersection numbers.

$$\alpha((b_{\tilde{v}})_{\tilde{v} \in \tilde{V}}) = \left(\sum_{\tilde{v} \in \tilde{V}} b_{\tilde{v}} \sum_{v \in \pi^{-1}(\tilde{v})} v.w \right)_{\tilde{w} \in \tilde{V}}.$$

$$\beta((b_{\tilde{v}})_{\tilde{v} \in \tilde{V}}) = \sum_{\tilde{v} \in \tilde{V}} b_{\tilde{v}} m_{\tilde{v}} |\tilde{v}|$$

Using the following two facts, one can check that the composition of the two maps above is zero: (i) for any $\tilde{v} \in \tilde{V}$ and for any $v \in \pi^{-1}(\tilde{v})$, we have $m_v = m_{\tilde{v}}$, and, (ii) the intersection number of any vertical divisor of X_s^{st} with the special fiber X_s^{st} is 0.

Theorem 2.8.14. [BL99, Theorem 1.17, Corollary 1.17] *Assume that k is perfect and that*

$\text{Gal}(\bar{k}/k)$ is procyclic. Let X be a regular S -curve. Let g be the genus of X_K . Let $m = \gcd(m_{\tilde{v}} \mid \tilde{v} \in \tilde{V})$ and let $\tilde{m} = \gcd(m_{\tilde{v}}|\tilde{v}| : \tilde{v} \in \tilde{V})$. Let Φ denote the étale k -group scheme corresponding to the component group of the Néron model of the Jacobian of X_K over S . Let $q = 1$ if $\tilde{m}|g - 1$ and $q = 2$ otherwise. Then qm divides \tilde{m} and there exists an exact sequence

$$0 \rightarrow \ker \beta / \text{im } \alpha \rightarrow \Phi(k) \rightarrow (qm\mathbb{Z})/\tilde{m}\mathbb{Z} \rightarrow 0. \quad (2.1)$$

Remark 2.8.15. The theorem above follows from an analysis of the long exact sequence in Galois cohomology associated to the short exact sequence of $\text{Gal}(\bar{k}/k)$ -modules

$$0 \rightarrow \text{im } \bar{\alpha} \rightarrow \ker \bar{\beta} \rightarrow \Phi(\bar{k}) \rightarrow 0,$$

where the maps $\bar{\alpha}$ and $\bar{\beta}$ are the α and β that appear in Theorem 2.8.11.

2.9 Hirzebruch–Jung continued fractions

Let n and r be positive integers, such that $0 < r < n$ and $\gcd(r, n) = 1$. The Hirzebruch–Jung continued fraction expansion $[b_1, b_2, \dots, b_\lambda]_{\text{HJ}}$ of n/r is given by

$$\frac{n}{r} = b_1 - \frac{1}{b_2 - \frac{1}{\dots - \frac{1}{b_\lambda}}},$$

where λ and b_i are positive integers with $b_i \geq 2$.

Let m_1, m_2 be positive integers such that $\gcd(m_1, n) = \gcd(m_2, n) = 1$ and $rm_2 + m_1 = 0 \pmod{n}$. If $\lambda = 1$, let $\mu_1 = (m_1 + m_2)/n$. Otherwise, let μ_i be the unique solution to the

system of equations

$$\begin{bmatrix} b_1 & -1 & & & & \\ -1 & b_2 & -1 & & & \\ & -1 & b_3 & -1 & & \\ & & & \ddots & & \\ & & & & -1 & b_{\lambda-1} & -1 \\ & & & & & -1 & b_\lambda \end{bmatrix} \begin{bmatrix} \mu_1 \\ \mu_2 \\ \vdots \\ \vdots \\ \mu_{\lambda-1} \\ \mu_\lambda \end{bmatrix} = \begin{bmatrix} m_2 \\ 0 \\ \vdots \\ \vdots \\ 0 \\ m_1 \end{bmatrix}.$$

We call $(\mu_1, \mu_2, \dots, \mu_\lambda)$ the multiplicity vector associated to the tuple (n, r, m_2, m_1) . For the proof of existence and uniqueness, see [CES03, Corollary 2.4.3].

Lemma 2.9.1.

$$\frac{n}{m_1 m_2} = \frac{1}{m_2 \mu_1} + \frac{1}{\mu_1 \mu_2} + \dots + \frac{1}{\mu_{\lambda-1} \mu_\lambda} + \frac{1}{\mu_\lambda m_1}.$$

Proof. We will prove this by induction on the length λ of the continued fraction expansion of n/r . Since $\gcd(n, r) = 1$, if $\lambda = 1$, it follows that $r = 1$, $b_1 = n$ and $\mu_1 = (m_1 + m_2)/n$, so

$$\frac{1}{m_2 \mu_1} + \frac{1}{\mu_1 m_1} = \frac{m_1 + m_2}{\mu_1 m_1 m_2} = \frac{n}{m_1 m_2}.$$

Now assume $\lambda > 1$. Let $n = b_1 r - r'$. We have $r m_2 + m_1 = n \mu_1$ by [CES03, Corollary 2.4.3]. One can then check that the continued fraction expansion of r/r' is given by $[b_2, \dots, b_\lambda]_{\text{HJ}}$. We also have

$$\begin{aligned} m_1 + r' \mu_1 &= m_1 + (b_1 r - n) \mu_1 \\ &= m_1 + b_1 r \mu_1 - n \mu_1 \\ &= m_1 + b_1 r \mu_1 - m_1 - r m_2 \\ &= r(b_1 \mu_1 - m_2) \\ &= r \mu_2. \end{aligned}$$

One can check (using the uniqueness statement in Section 2.9) that the multiplicity vector associated to the tuple (r, r', μ_1, m_1) equals $(\mu_2, \dots, \mu_\lambda)$. The induction hypothesis applied

to the tuple (r, r', μ_1, m_1) (in place of the original (n, r, m_2, m_1)) then tells us that

$$\frac{r}{m_1\mu_1} = \frac{1}{\mu_1\mu_2} + \dots + \frac{1}{\mu_{\lambda-1}\mu_\lambda} + \frac{1}{\mu_\lambda m_1}.$$

Now,

$$\begin{aligned} \frac{n}{m_1 m_2} &= \frac{m_1 + r m_2}{\mu_1 m_1 m_2} \\ &= \frac{1}{m_2 \mu_1} + \frac{r}{m_1 \mu_1} \\ &= \frac{1}{m_2 \mu_1} + \frac{1}{\mu_1 \mu_2} + \dots + \frac{1}{\mu_{\lambda-1} \mu_\lambda} + \frac{1}{\mu_\lambda m_1}. \end{aligned} \quad \square$$

Lemma 2.9.2. $\gcd(m_1, m_2) = \gcd(m_1, \mu_1, \mu_2, \dots, \mu_\lambda, m_2)$.

Proof. We prove this by induction on λ . First let $\lambda = 1$. Then $\mu_1 = (m_1 + m_2)/n$. Since $\gcd(m_1, n) = \gcd(m_2, n) = 1$, it follows that $\gcd(m_1, \mu_1, m_2) = \gcd(m_1, m_1 + m_2, m_2) = \gcd(m_1, m_2)$. Now let $\lambda > 1$. With the same notation as in the proof of Lemma 2.9.1, the induction hypothesis will imply that $\gcd(\mu_1, m_1) = \gcd(m_1, \mu_1, \mu_2, \dots, \mu_\lambda)$. Therefore $\gcd(\mu_1, m_1, m_2) = \gcd(m_1, \mu_1, \mu_2, \dots, \mu_\lambda, m_2)$. Since $\gcd(m_1, n) = \gcd(m_2, n) = 1$, it follows that $\gcd(\mu_1, m_1, m_2) = \gcd(r m_2 + m_1, m_1, m_2) = \gcd(m_1, m_2)$. \square

2.10 Behaviour of regular models under tame extensions

Let R and K be as in the beginning of this chapter. Let X be a snc model of a nice K -curve of genus $g \geq 1$. Let \mathbb{N}' be the set of positive integers not divisible by the characteristic of k . For $d \in \mathbb{N}'$, let $K(d)$ denote the unique tamely ramified extension of K of degree d and let $R(d)$ denote its ring of integers. Let $S(d) = \text{Spec } R(d)$. Let X_d denote the normalization of $X \times_S S(d)$. Let $X(d)$ denote the minimal desingularization of X_d . In [HN12, Chapter 3], Halle and Nicaise prove that $X(d)$ is again a snc model and describe its special fiber in terms of the special fiber of X . In this section, we recall the necessary results from their book that we will need in Chapter 4.

Let $X_s = \sum_{i \in I} N_i E_i$, where the E_i are the (reduced) irreducible components of X_s and

N_i is the multiplicity of E_i in X_s . For each $i \in I$, let $E_i^\circ = E_i - \bigcup_{j \neq i} E_j$. For any subset $S \subset X_s$, we let \overline{S} denote its Zariski closure in X_s .

Proposition 2.10.1. [HN12, Chapter 3, Proposition 1.3.2] *Let $d \in \mathbb{N}'$.*

- (i) *For each irreducible component E_i of X_s , the scheme $F_i := X_d \times_X E_i$ is a disjoint union of smooth irreducible curves F_{ij} . The multiplicity N'_i of each component F_{ij} in $(X_d)_s$ is given by $N'_i = N_i / \gcd(d, N_i)$, and the morphism $X_d \times_X E_i^\circ \rightarrow E_i^\circ$ is a Galois cover of degree $\gcd(d, N_i)$.*
- (ii) *If E_i is a rational curve such that the set-theoretic intersection $E_i \cap \overline{(X_s - E_i)}$ consists of precisely one (respectively two) point(s), i.e., $\sum_{j \neq i} E_j \cdot E_i \in \{1, 2\}$, then each F_{ij} is a rational curve such that $F_{ij} \cap \overline{((X_d)_s - F_{ij})}$ consists of precisely one (respectively two) point(s). In both cases, the number of connected components of F_i is equal to $n_i := \gcd(N_i, N_a, d)$ where a is any element of $I - \{i\}$ such that E_a intersects E_i . In particular, the gcd does not depend on the choice of a .*
- (iii) *Each nonregular point of X_d is an intersection point of two distinct irreducible components of the special fiber. Let $x \in (X_d)_s$ be a point that belongs to the intersection of two distinct irreducible components F and F' which dominate irreducible components E and E' of X_s respectively. Let N and N' be the multiplicities of E and E' in X_s respectively. Then the special fiber of the minimal desingularization Z of the local germ $\text{Spec } \mathcal{O}_{X_d, x}$ is a divisor with strict normal crossings whose combinatorial data (i.e. multiplicities of components and their intersection numbers; see Proposition 2.10.2 below) depend only on N, N' and d . Moreover, each exceptional component of Z_s is a rational curve that meets the other irreducible components of Z_s in precisely two points.*

In particular, the $S(d)$ -scheme $X(d)$ is a snc model of $X \times_K K(d)$.

Proposition 2.10.2. [HN12, Chapter 3, Proposition 4.2.5] *Retain the notation in Proposition 2.10.1(iii). The special fiber of the minimal desingularization Z of the local germ $\text{Spec } \mathcal{O}_{X_d, x}$ consists of a chain of (-2) curves that connect the strict transforms of F and F' . The multiplicities of the (-2) curves in the chain can be computed by the following procedure. Let $g = \gcd(N, N', d)$, $h = \gcd(N, d)$, $h' = \gcd(N', d)$, $n = N/h$, $n' = N'/h'$, $d' =$*

$(dg)/hh'$. Let r be the unique solution to the equation $rn + n' = 0 \pmod{d'}$ such that $0 < r < d'$. Let $[b_1, b_2, \dots, b_\lambda]_{\text{HJ}}$ be the Hirzebruch–Jung continued fraction expansion of d'/r . Let $(\mu_1, \dots, \mu_\lambda)$ be the multiplicity vector associated to the tuple (d', r, n, n') . Then there are λ components in the chain joining the strict transform of F and the strict transform of F' in $\mathcal{C}(d)_s$. Their multiplicities in order are $\{\mu_1, \mu_2, \dots, \mu_\lambda\}$.

Definition 2.10.3. [HN12, Chapter 3, Definition 2.2.2] A component Γ of X_s is principal if

- either the genus of Γ is nonzero, or,
- $\Gamma - \Gamma^\circ$ contains at least 3 points.

Since we assumed that the genus of X_η is nonzero, it follows that there exists a minimal snc model X_{\min} of X_η [Liu02, Chapter 9, Proposition 3.36].

Definition 2.10.4. [HN12, Chapter 3, Definition 2.2.3] Let I denote the set of principal components of X . The stabilization index $e(X)$ of X is defined by

$$e(X) := \operatorname{lcm}_{\Gamma \in I} m_\Gamma.$$

Also, the stabilization index $e(X_\eta)$ of X_η is defined by

$$e(X_\eta) := e(X_{\min}).$$

Lemma 2.10.5. [HN12, Chapter 3, Lemma 2.3.2] *Assume either that the genus of X_η is ≥ 2 , or that X_η is a genus 1 curve with a rational point, or that X_η is a genus 1 curve whose Jacobian has additive or good reduction. Let $d \in \mathbb{N}'$ be an element that is prime to $e(X)$.*

- (i) *Then for every (reduced) irreducible component E_i of X_s , the k -scheme $F_i = X_d \times_X E_i$ is smooth and irreducible.*
- (ii) *Let N'_i be the multiplicity of F_i in $(X_d)_s$. Then $N'_i = N_i / \gcd(d, N_i)$, and $F_i \rightarrow E_i$ is a ramified tame Galois cover of degree $\gcd(d, N_i)$.*
- (iii) *If E_i is principal, or E_i is a rational curve such that $E_i \cdot \sum_{j \neq i} E_j = 1$, then $F_i \rightarrow E_i$ is an isomorphism and $N'_i = N_i$.*

- (iv) If E_i is a rational curve such that $E_i \cdot \sum_{j \neq i} E_j = 2$, then $F_i \simeq \mathbb{P}_k^1$ and $F_i \rightarrow E_i$ is either an isomorphism, or ramified over the two points of $E_i - E_i^\circ$.
- (v) Moreover, if i and j are distinct elements of I , then over any point of $E_i \cap E_j$ lies exactly one point of $F_i \cap F_j$.

2.11 Néron component series

Let X be a regular S -curve. Let \mathcal{A} denote the Néron model of the Jacobian of X_K . For $d \in \mathbb{N}'$, let $\mathcal{A}(d)$ denote the Néron model of the Jacobian of $X \times_K K(d)$. Since the construction of the Néron model does not commute with base extension, it is natural to ask how much $\mathcal{A} \times_R R(d)$ and $\mathcal{A}(d)$ differ. The behaviour of the order of the component group under tame extensions is recorded in a precise fashion by the Néron component series

$$\sum_{d \in \mathbb{N}'} |\Phi(\mathcal{A}(d))| T^d.$$

One of the key results in [HN12] is a proof of the rationality of the Néron component series [HN12, Chapter 3, Theorem 3.1.5]. The main ingredient in the proof of this result is the following theorem.

Theorem 2.11.1. [HN12, Chapter 3, Proposition 3.1.1] *Let t denote the toric rank of \mathcal{A} . Let K'/K be a finite tame extension of K whose degree d is prime to $e(X_\eta)$. Then*

$$|\Phi(\mathcal{A} \times_K K')| = d^t |\Phi(\mathcal{A})|.$$

The proof given by Halle and Nicaise involves a reduction to the equicharacteristic case. We provide an alternate proof of this result in Section 4.1.9.

Chapter 3

Comparing conductors and discriminants

The invariants $-\text{Art}(X/S)$ and $\nu(\Delta)$ are unchanged when we extend scalars to the strict henselization. So from the very beginning, we let R be a henselian discrete valuation ring with separably closed residue field k . Assume that $\text{char } k \neq 2$. Let t be a uniformizer of R , i.e., $\nu(t) = 1$. Let C be a hyperelliptic curve over K with K -rational Weierstrass points and genus $g \geq 2$.

We first show that we can find a minimal Weierstrass equation such that f is a monic, separable polynomial of degree $2g + 2$ in $R[x]$ that splits completely; $f(x) = (x - b_1)(x - b_2) \dots (x - b_{2g+2})$ in $R[x]$. Let $y^2 - h(x)$ be any minimal Weierstrass equation for C . Let $H(x, z) = z^{2g+2}g(x/z)$. Choose a point $\tilde{P} \in \mathbb{P}^1(k)$ that is not a zero of H and let $P \in \mathbb{P}^1(R)$ be a lift of \tilde{P} ; $P \bmod t = \tilde{P}$. Since $\text{GL}_2(R)$ acts transitively on $\mathbb{P}^1(R)$, we can find $\varphi \in \text{GL}_2(R)$ that sends P to $[1 : 0] \in \mathbb{P}^1_R$. Then if $F(x, z) = \varphi \cdot H(x, z)$, then $F(x, 1)$ is of degree $2g + 2$ and $u := F(1, 0) \in R$ is a unit. Let $f(x) = u^{-1}F(x, 1)$. Since $\text{char } k \neq 2$ and R is henselian with algebraically closed residue field, we can find a $u' \in R$ such that $u'^2 = u$. This tells us that by scaling y by u' , we obtain a Weierstrass equation $y^2 - f(x)$ for C such that $f(x)$ is monic and separable of degree $2g + 2$. Since $\det \varphi$ is a unit in R , and the discriminant of f differs from the discriminant of h by a power of $\det \varphi$, it follows that $y^2 - f(x)$ is a minimal Weierstrass equation for C . Fix such an equation.

We will denote the fraction field of an integral scheme Z by $K(Z)$, the local ring at a point z of a scheme Z by $\mathcal{O}_{Z,z}$ and the unique maximal ideal in $\mathcal{O}_{Z,z}$ by $\mathfrak{m}_{Z,z}$. The reduced

scheme attached to a scheme Z will be denoted Z_{red} .

3.1 Construction of the regular model

We first prove a lemma that gives sufficient conditions for the normalization of a regular 2-dimensional scheme in a degree 2 extension of its function field to be regular.

Lemma 3.1.1. *Let Y be a regular integral 2-dimensional scheme and let f be a rational function on Y that is not a square. Assume that the residue field at any closed point of Y is not of characteristic 2. (Weil divisors make sense on Y .) Let $(f) = \sum_{i \in I} m_i \Gamma_i$. Assume that*

- (a) *Any two Γ_i for which m_i is odd do not intersect.*
- (b) *Any Γ_i for which m_i is odd is regular.*

Then, the normalization of Y in $K(Y)(\sqrt{f})$ is regular.

Proof. We will sketch the details of the proof. The construction of the normalization is local on the base. Therefore, it suffices to check that for every closed point y of Y , the normalization of the corresponding local ring $\mathcal{O}_{Y,y}$ in $K(Y)(\sqrt{f})$ is regular. There are two cases to consider.

The first case is when m_i is even for every Γ_i that contains y . In this case, since $\mathcal{O}_{Y,y}$ is a regular and hence a unique factorization domain, we can write $f = (c_1/c_2)^2 u$ for some $c_1, c_2 \in \mathcal{O}_{Y,y} - \{0\}$ and a unit $u \in \mathcal{O}_{Y,y}$. Using the fact that 2 is a unit in $\mathcal{O}_{Y,y}$ for every y , a standard computation then shows that the normalization of $\mathcal{O}_{Y,y}$ in $K(Y)(\sqrt{f})$ is $\mathcal{O}_{Y,y}[z]/(z^2 - u)$. From this presentation, we conclude that the normalization is étale over $\mathcal{O}_{Y,y}$, and hence regular by [BLR90, Proposition 9].

The second case is when exactly one of the m_i is odd for the Γ_i that contain y . Let a be an irreducible element of the unique factorization domain $\mathcal{O}_{Y,y}$, corresponding to the unique Γ_i for which m_i is odd. In this case, $f = (c_1/c_2)^2 au$, where $c_1, c_2 \in \mathcal{O}_{Y,y} - \{0\}$ and u is a unit in $\mathcal{O}_{Y,y}$ as before. One can then check that the normalization of $\mathcal{O}_{Y,y}$ in $K(Y)(\sqrt{f})$ is $\mathcal{O}_{Y,y}[z]/(z^2 - au)$. Since Γ_i is regular at y , we can find an element $b \in \mathcal{O}_{Y,y}$ such that a and

b generate the maximal ideal of $\mathcal{O}_{Y,y}$. One can then check that z and b generate the unique maximal ideal of $\mathcal{O}_{Y,y}[z]/(z^2 - au)$. This implies that $\mathcal{O}_{Y,y}[z]/(z^2 - au)$ is regular. \square

Remark 3.1.2. The construction of a regular model in Lemma 3.1.1 as the normalization of a regular scheme in a degree 2 extension of the function field, is special to hyperelliptic curves. A similar construction exists for tricyclic covers of the projective line, but it does not extend to other Galois covers [LL99].

In our example, $Y = \mathbb{P}_R^1$ and the rational function f is $(x - b_1)(x - b_2) \dots (x - b_{2g+2})$. The divisor of f is just the sum of the irreducible principal horizontal divisors $(x - b_i)$, all appearing with multiplicity 1 in (f) , and the divisor at ∞ (the closure of the point at ∞ on the generic fiber), with multiplicity $-(2g + 2)$. If the b_i belong to distinct residue classes modulo t , then the condition in the lemma is satisfied and we get the regular scheme $\text{Proj} \frac{R[x,y,z]}{y^2 - z^{2g+2}f(x/z)}$. If some of the b_i belong to the same residue class, then the corresponding horizontal divisors would intersect at the closed point on the special fiber given by this residue class and we cannot apply the lemma directly with $Y = \mathbb{P}_R^1$. We will instead apply the lemma to the divisor of f on an iterated blow-up of \mathbb{P}_R^1 . The generic fiber of this new Y is still \mathbb{P}_K^1 , so the regular scheme that we obtain will still be a relative S -curve with generic fiber the hyperelliptic curve we started with.

We will need another lemma to show that we can resolve the issue discussed above by replacing \mathbb{P}_R^1 by an iterated blow-up of \mathbb{P}_R^1 . The following lemma is a minor modification of [LL99, Lemma 1.4], where we consider irreducible divisors appearing in the divisor of an arbitrary rational function on a model (instead of the rational function t) and the order of vanishing of f along these divisors instead. We recover [LL99, Lemma 1.4] by taking f to be t .

Lemma 3.1.3. *Let Y/R be a regular model of a curve Y_η/K . Let f be a rational function on Y . Let C and D be irreducible divisors of Y that appear in the divisor of f , and let the order of vanishing of f along C and D be r_C and r_D respectively. Let $y \in Y$ be a closed point, and let Y' denote the model of Y_η obtained by blowing up Y at y . Let $E \subset Y'$ denote the exceptional divisor.*

- (a) If y is a regular point of C that does not belong to any other irreducible divisor appearing in (f) , then the order of vanishing of f along E equals r_C .
- (b) If $y \in C \cap D$ and does not belong to any other divisors appearing in (f) , and if C and D intersect transversally at y , then the order of vanishing of f along E is $r_C + r_D$.

Proof. Omitted. This can be seen using explicit equations of the blow-up in a neighbourhood of y . □

We are now ready to construct the regular model X of C . A very similar construction already appears in [Kau99] under some additional simplifying hypotheses. The model that is obtained there turns out to be semistable. The regular model X that is constructed below is not necessarily semistable.

Let D_i be the irreducible principal horizontal divisor $(x - b_i)$ on \mathbb{P}_R^1 . First blow-up \mathbb{P}_R^1 at those closed points on the special fiber where any two of the D_i intersect to obtain a new scheme $\text{Bl}_1(\mathbb{P}_R^1)$. On this scheme, the strict transforms of any two divisors D_i and D_j for which the b_i agree mod t and not mod t^2 will no longer intersect. If some of the b_i agree mod t^2 as well, then continue to blow-up (that is, now blow up $\text{Bl}_1(\mathbb{P}_R^1)$ at the closed points on the special fiber of $\text{Bl}_1(\mathbb{P}_R^1)$ where any two of the strict transforms of the divisors $(x - b_i)$ intersect, and call the result $\text{Bl}_2(\mathbb{P}_R^1)$). Since the b_i are pairwise distinct, we will eventually end up with a scheme $\text{Bl}_n(\mathbb{P}_R^1)$ where no two of the irreducible horizontal divisors occurring in (f) intersect. We may hope to set Y equal to $\text{Bl}_n(\mathbb{P}_R^1)$, but the divisor of the rational function f might now vanish along some irreducible components of the special fiber.

Lemma 3.1.3 now tells us that a single blow-up of $\text{Bl}_n(\mathbb{P}_R^1)$ based at a finite set of closed points will ensure that no two components where f vanishes to odd order intersect. Do this as well and call the resulting scheme Y . Call an irreducible component of the special fiber of Y even if the order of vanishing of f along this component is even. Similarly define odd component. Similarly define odd and even components of $\text{Bl}_n(\mathbb{P}_R^1)$.

Recall the notion of a good model as defined in [LL99, 1.8]. A regular model Y/\mathcal{O}_K of Y_η/K is good if it satisfies the following two conditions:

- (a) The (reduced) irreducible components of Y_s are smooth.

- (b) Each singular point of $(Y_s)_{\text{red}}$ belongs to exactly two irreducible components of $(Y_s)_{\text{red}}$ and these components intersect transversally.

The blow-up of a good model at a closed point is again a good model.

The model Y we have constructed is a good model of \mathbb{P}_K^1 as it is obtained using a sequence of blow-ups starting from the good model \mathbb{P}_R^1 of \mathbb{P}_K^1 . The model $\text{Bl}_n(\mathbb{P}_R^1)$ is the model we would get using [LL99, Lemma 1.9] if we start with the model \mathbb{P}_R^1 and the divisor (f) on it. Set X to be equal to the normalization of Y in $K(Y)(\sqrt{f})$.

Theorem 3.1.4. *The scheme X/S is regular.*

Proof. The components of Y_s are smooth and the divisor (f) satisfies the conditions in the statement of Lemma 3.1.1. It follows that X is regular. \square

We will now prove that X is a good model of C and compute the multiplicities of the components of the special fiber of X . Let the divisor of t on X be $\sum m_i \Gamma_i$; here the sum runs over all irreducible components of the special fiber X_s and the Γ_i are integral divisors on X . Let ψ denote the map $X \rightarrow \text{Bl}_n(\mathbb{P}_R^1)$.

Lemma 3.1.5.

- (a) *The scheme X is a good model of C .*
- (b) *Each m_i is 1 or 2. Furthermore, $m_i = 2$ if and only if either*
- (i) $\psi(\Gamma_i)$ is an odd component of $(\text{Bl}_n(\mathbb{P}_R^1))_s$, or,*
 - (ii) $\psi(\Gamma_i) = \Gamma \cap \Gamma'$ for two distinct odd components Γ and Γ' of $(\text{Bl}_n(\mathbb{P}_R^1))_s$.*

Proof.

- (a) Let S be the set of odd components of Y_s and let B be the divisor $\sum_{\Gamma \in S} \Gamma + \sum_{i=1}^{2g+2} \overline{\{b_i\}}$ where $\overline{\{b_i\}}$ is the horizontal divisor that is the closure of the point b_i on the generic fiber \mathbb{P}_K^1 . Since the map $X \rightarrow Y$ is finite of degree 2, the image of an irreducible component of X_s is an irreducible component of Y_s , and there are at most two irreducible components of X_s mapping down to an irreducible component of Y_s . All the irreducible components

of Y_s are isomorphic to \mathbb{P}_k^1 . There are two irreducible components of X_s mapping down to a given component of Y_s only when the component of Y_s is an even component that does not intersect any of the irreducible divisors appearing in B . In this case the two components in X_s that map down to the given component of Y_s do not intersect, and are isomorphic to \mathbb{P}_k^1 . In all other cases there is a unique component of X_s mapping down to a component of Y_s .

Since at most two irreducible components of Y_s pass through any given point of Y_s , we see that this implies that at most two irreducible components of X_s pass through any given point of X_s . The intersection point x of two irreducible components of X_s has to map to the intersection point y of two irreducible components of Y_s . If y is the intersection of two even components, then the map ψ is étale at x , so the intersection is still transverse. If y is the intersection of an even and odd component, because the intersection of these components is transverse, we can pick the function g in the proof of Lemma 3.1.1 to be a uniformizer for the even component. This shows that étale locally, the two components that intersect at x are given by the vanishing of $\sqrt{t_j u}$ and g and as these two elements generate the maximal ideal at x étale locally, the intersection is transverse once again. For a closed point x on X_s lying on exactly one component Γ of X_s , the same argument shows that we can choose a system of parameters at the point such that one of them cuts out the component Γ of X_s . This shows that the irreducible components of X_s are smooth.

- (b) A repeated application of [LL99, Lemma 1.4] tells us that the multiplicity of every irreducible component of $(\text{Bl}_n(\mathbb{P}_R^1))_s$ is 1. The same lemma tells us that Y_s has a few additional components of multiplicity either 1 or 2 - If we blow up the closed point that is the intersection of an odd component of the special fiber of $\text{Bl}_n(\mathbb{P}_R^1)$ with a horizontal divisor appearing in (f) , then we get a component of multiplicity 1 in the special fiber and if we blow up the intersection of two odd components of the special fiber, we get a component of multiplicity 2. Since f vanishes to an even order along components of multiplicity 2 in Y_s , each m_i is either 1 or 2 - It is 1 if Γ_i maps down to an even component of Y_s and its image in $(\text{Bl}_n(\mathbb{P}_R^1))_s$ does not equal the intersection point of two components

of the special fiber and it is 2 otherwise. This is because $\mathcal{O}_{Y,\eta(\psi(\Gamma_i))} \rightarrow \mathcal{O}_{X,\eta(\Gamma_i)}$ is an extension of discrete valuation rings (here $\eta(C)$ for an integral curve C denotes its generic point), and the corresponding extension of fraction fields is of degree 2. t is a uniformizer in $\mathcal{O}_{Y,\eta(\psi(\Gamma_i))}$, so its valuation above is either 1 or 2 depending on whether the extension is ramified at (t) or not. The extension is not ramified if the image of Γ_i in Y is an even component. \square

3.2 An explicit formula for the Deligne discriminant

The Deligne discriminant of the model X is $-\text{Art}(X/S) := -\chi(X_{\bar{\eta}}) + \chi(X_s) + \delta$, where δ is the Swan conductor associated to the ℓ -adic representation $\text{Gal}(\bar{K}/K) \rightarrow \text{Aut}_{\mathbb{Q}_\ell}(H_{\text{ét}}^1(X_{\bar{\eta}}, \mathbb{Q}_\ell))$ ($\ell \neq \text{char } k$) (Section 2.3).

Lemma 3.2.1.

$$-\text{Art}(X/S) = -\chi(X_{\bar{\eta}}) + \chi(X_s) = \sum_i \left((1 - m_i)\chi(\Gamma_i) + \sum_{j \neq i} (m_j - 1)\Gamma_i \cdot \Gamma_j \right) + \sum_{i < j} \Gamma_i \cdot \Gamma_j.$$

Proof. Since all irreducible components of X_s have multiplicity either 1 or 2 in the special fiber and $\text{char } k \neq 2$, [Sai87, Theorem 3] implies that $\delta = 0$.

Using the intersection theory for regular arithmetic surfaces, for a canonical divisor K

on X , we have

$$\begin{aligned}
-\chi(X_{\bar{\eta}}) &= 2p_a(X_{\bar{\eta}}) - 2 \\
&= 2p_a(X_s) - 2 \\
&= X_s.(X_s + K) \\
&= X_s.K \quad (\text{because } X_s \text{ is a complete fiber, } X_s.X_s = 0) \\
&= \sum_i m_i \Gamma_i.K \\
&= \sum_i m_i (-\chi(\Gamma_i) - \Gamma_i.\Gamma_i) \quad (\text{by the adjunction formula applied to the divisor } \Gamma_i) \\
&= \sum_i \left(-m_i \chi(\Gamma_i) + \sum_{j \neq i} m_j \Gamma_j.\Gamma_i \right).
\end{aligned}$$

The last equality is obtained from $X_s.\Gamma_i = 0$.

Let $\lambda: \sqcup \Gamma_i \rightarrow (X_s)_{\text{red}}$ be the natural map which is just the inclusion of each Γ_i into $(X_s)_{\text{red}}$. Since the Γ_i are smooth, [Lor90, Theorem 2.6] tells us that $\chi(X_s) = \chi((X_s)_{\text{red}}) = -\delta_{X_s} + \sum \chi(\Gamma_i)$ where $\delta_{X_s} = \sum_{P \in (X_s)_{\text{red}}} (|\lambda^{-1}(P)| - 1)$. In our case δ_{X_s} is just the number of points where two components of X_s meet. Since the intersections in X_s are all transverse,

$$\delta_{X_s} = \sum_{i < j} \Gamma_i.\Gamma_j = \sum_i \sum_{j \neq i} \Gamma_i.\Gamma_j - \sum_{i < j} \Gamma_i.\Gamma_j.$$

Putting all this together, we can rewrite $\chi(X_s)$ in the following form

$$\chi(X_s) = \sum_i \left(\chi(\Gamma_i) - \sum_{j \neq i} \Gamma_i.\Gamma_j \right) + \sum_{i < j} \Gamma_i.\Gamma_j.$$

This expression, together with the formula above for $-\chi(X_{\bar{\eta}})$ gives

$$-\text{Art}(X/S) = \sum_i \left((1 - m_i) \chi(\Gamma_i) + \sum_{j \neq i} (m_j - 1) \Gamma_i.\Gamma_j \right) + \sum_{i < j} \Gamma_i.\Gamma_j. \quad \square$$

Remark 3.2.2. The formula

$$-\chi(X_{\bar{\eta}}) + \chi(X_s) = \sum_i \left((1 - m_i)\chi(\Gamma_i) + \sum_{j \neq i} (m_j - 1)\Gamma_i \cdot \Gamma_j \right) + \sum_{i < j} \Gamma_i \cdot \Gamma_j$$

holds for any regular S curve X with smooth, projective, geometrically integral generic fiber and whose special fiber is a strict simple normal crossings divisor (i.e., the components themselves might have multiplicities bigger than 1, but each of the components is smooth, and the reduced special fiber has at worst nodal singularities). We also recover the result that if X/S is regular and semistable, then $-\text{Art}(X/S) = \sum_{i < j} \Gamma_i \cdot \Gamma_j$, since in this case $m_i = 1$ for all i and $\delta = 0$ by [Sai87, Theorem 3].

3.3 Dual graphs

By the construction of X we have a sequence of maps $X \rightarrow Y \rightarrow \text{Bl}_n(\mathbb{P}_R^1) \rightarrow \mathbb{P}_R^1$. Let T_X be the dual graph of X_s , i.e., the graph with vertices the irreducible components of X_s , and an edge between two vertices if the corresponding irreducible components intersect. (In this chapter, it is not necessary for graphs to have a weight function, so we refrain from defining one.) Let T_Y be the dual graph of Y_s and T_B the dual graph of $(\text{Bl}_n(\mathbb{P}_R^1))_s$. For a vertex v of any of the graphs T_X, T_Y or T_B , the irreducible component corresponding to the vertex in the respective dual graph will be denoted Γ_v . Let ψ_1 denote the map $X \rightarrow Y$ and let ψ_2 the map $Y \rightarrow \text{Bl}_n(\mathbb{P}_R^1)$. Let $\psi = \psi_2 \circ \psi_1$.

We will denote the vertices of a graph G by $V(G)$. For any $v \in V(G)$, let $N(v)$ (for neighbours of v) denote the set of vertices w for which there is an edge between v and w . If G is a directed graph and $v \in V(G)$, let $C(v)$ (for children of v) denote the set of vertices w for which there is an edge pointing from v to w .

The graph T_B naturally has the structure of a rooted tree (remembering the sequence of blow-ups, i.e., whether the component was obtained as a result of a blow-up at a closed point of the other component). The graph T_Y is obtained from the graph of T_B by attaching some additional vertices between two pre-existing vertices connected by an edge and some additional leaves, so T_Y is also a tree. By virtue of being rooted trees, the edges of T_B and

T_Y can be given a direction (and we choose the direction that points away from the root).

There is a natural surjective map $\varphi_1 : V(T_X) \rightarrow V(T_Y)$: if the image of an irreducible component $\Gamma_{v''}$ of X_s under ψ_1 is an irreducible component $\Gamma_{v'}$ of Y_s then let $\varphi_1(v'') = v'$. If two vertices of T_X are connected by an edge, so are their images in T_Y . We can use this surjection to transfer the direction on the edges of T_Y to the edges of T_X ; this makes T_X a directed graph. Call a vertex of T_B odd (respectively even) if the order of vanishing of f along the corresponding component is odd (respectively even). Similarly define odd and even vertices of T_Y . This definition is consistent with the earlier definition of odd and even components of Y and $\text{Bl}_n(\mathbb{P}_R^1)$.

3.4 Deligne discriminant and dual graphs

The last term $\sum_{i < j} \Gamma_i \cdot \Gamma_j$ in the Deligne discriminant can be thought of as the sum

$$\sum_{v'' \in V(T_X)} \left(\sum_{w'' \in C(v'')} \Gamma_{v''} \cdot \Gamma_{w''} \right).$$

We use this observation to decompose the Deligne discriminant as a sum over the vertices of the graph T_X . Let $m_{v''}$ be the multiplicity of $\Gamma_{v''}$ in X_s . We then have

$$-\text{Art}(X/S) = \sum_{v'' \in V(T_X)} \left((1 - m_{v''}) \chi(\Gamma_{v''}) + \sum_{w'' \in N(v'')} (m_{w''} - 1) \Gamma_{v''} \cdot \Gamma_{w''} + \sum_{w'' \in C(v'')} \Gamma_{v''} \cdot \Gamma_{w''} \right).$$

3.5 Description of the strategy

To compare the discriminant d_f of the polynomial f with the valuation of the Deligne discriminant of the model X , it would be useful if we could decompose d_f as a sum of local terms. In the next section, we will show that there is a way to decompose the minimal discriminant as a sum over the vertices of T_B . There is a simple relation between the irreducible components of X_s and those of $(\text{Bl}_n(\mathbb{P}_R^1))_s$ (which we will describe below), so we will be able to compare the two discriminants using this decomposition, by first comparing

them locally.

The image of an irreducible component of Y_s under ψ_2 is either an irreducible component of $(\text{Bl}_n(\mathbb{P}_R^1))_s$ or a point that lies on exactly one of the irreducible components of $(\text{Bl}_n(\mathbb{P}_R^1))_s$ or the intersection point of two irreducible components of $(\text{Bl}_n(\mathbb{P}_R^1))_s$. This induces a surjective map $\varphi_2 : V(T_Y) \rightarrow V(T_B)$ where the vertex corresponding to an irreducible component of Y_s is mapped either to the vertex corresponding to the unique irreducible component that its image is contained in or to the smaller of the two vertices (by which we mean the vertex closer to the root) corresponding to the two irreducible components that its image is contained in. Let $\varphi = \varphi_1 \circ \varphi_2$.

We have written the Deligne discriminant as $\sum_{v'' \in V(T_X)} \cdots$ and we can rewrite this sum as $\sum_{v \in V(T_B)} (\sum_{v'' \in V(T_X), \varphi(v'')=v} \cdots)$, so the Deligne discriminant can be regarded as a sum over the vertices of T_B .

The discussion above implies the following lemma, which will be useful later on in an explicit computation of the Deligne discriminant.

Lemma 3.5.1. *Let $v'' \in V(T_X)$.*

- (a) *If $w'' \in C(v'')$, then $\varphi_1(w'') \in C(\varphi_1(v''))$. In particular, if $w'' \in N(v'')$, then $\varphi_1(w'') \in N(\varphi_1(v''))$.*
- (b) *Let $w'' \in C(v'')$. If $\psi(\Gamma_{w''})$ is a point, then $\varphi(w'') = \varphi(v'')$ and $\varphi(v'')$ is an odd vertex. Otherwise, $\varphi(w'') \in C(\varphi(v''))$.*

3.6 A decomposition of the minimal discriminant

To each vertex v of T_B , we want to associate an integer $d(v)$ such that the minimal discriminant equals $\sum_{v \in V(T_B)} d(v)$. We will now define $d(v)$ by inducting on the vertices of T_B .

For the base case, note that if the b_i belong to distinct residue classes modulo t , then $\text{Bl}_n(\mathbb{P}_R^1) = \mathbb{P}_R^1$ and T_B is the graph with a single vertex v . The minimal discriminant is 0, so we set $d(v) = 0$.

The scheme $\text{Bl}_n(\mathbb{P}_R^1)$ was obtained as an iterated blow-up of \mathbb{P}_R^1 while trying to separate the horizontal divisors $(x - b_i)$ corresponding to the linear factors of f . This can be done for any separable polynomial $g \in R[x]$ that splits completely – let $\text{Bl}(g)$ denote the iterative blow up of \mathbb{P}_R^1 that one obtains while trying to separate the divisors corresponding to the linear factors of g . With this notation $\text{Bl}(f)$ equals the scheme $\text{Bl}_n(\mathbb{P}_R^1)$ we had above.

Let A be the set of residues of the b_i modulo t . For a residue $a \in A$, let the weight of the residue a ($:= \text{wt}_a$), be the number of b_i belonging to the residue class of a . Observe that the subtrees of the root of T_B are in natural bijection with the residues of weight strictly larger than 1.

The minimal discriminant $\nu(\Delta)$ ($= \nu(d_f)$) can be decomposed as follows:

$$\begin{aligned} \nu(d_f) &= \sum_{\substack{a \in A \\ \text{wt}_a > 1}} \nu \left(\prod_{\substack{b_i \bmod t = a \\ b_j \bmod t = a \\ i \neq j}} (b_i - b_j) \right) \\ &= \sum_{\substack{a \in A \\ \text{wt}_a > 1}} \nu \left(t^{\text{wt}_a(\text{wt}_a - 1)} \prod_{\substack{b_i \bmod t = a \\ b_j \bmod t = a \\ i \neq j}} \left(\frac{b_i - b_j}{t} \right) \right) \\ &= \sum_{a \in A} \text{wt}_a(\text{wt}_a - 1) + \sum_{\substack{a \in A \\ \text{wt}_a > 1}} \nu \left(\prod_{\substack{b_i \bmod t = a \\ b_j \bmod t = a \\ i \neq j}} \left(\frac{b_i - b_j}{t} \right) \right). \end{aligned}$$

Set $d(\text{root of } T_B) = \sum_{a \in A} \text{wt}_a(\text{wt}_a - 1)$. Pick an element b_i belong to the residue class $a \in A$ of weight strictly bigger than 1. The subtree corresponding to the residue a can naturally be identified with the dual graph of $\text{Bl}(g_a)_s$ for the polynomial $g_a = \prod_{b_j \bmod t = a} (x - \frac{b_j - b_i}{t})$.

Let d_a denote the discriminant of g_a . Then

$$\nu(d_f) = \sum_{a \in A} \text{wt}_a(\text{wt}_a - 1) + \sum_{a \in A, \text{wt}(a) > 1} \nu(d_a).$$

Now recursively decompose $\nu(d_a)$ as a sum over the vertices of the dual graph of $\text{Bl}(g_a)_s$.

Identifying the dual graph of $\text{Bl}(g_a)_s$ with the corresponding subtree in T_B , this gives us a way to decompose the minimal discriminant as a sum over the vertices of T_B .

We will now prescribe a way to attach weights to the vertices of T_B and give an explicit formula for $d(v)$ in terms of these weights.

3.6.1 Weight of a vertex

Suppose $v \in V(T_B)$. Let T_v be the complete subtree of T_B with root v . The complete subtree of T_B with root v has as its set of vertices all those vertices of T_B whose path to the root crosses v . There is an edge between two vertices in this subtree if there is an edge between them when considered as vertices of T_B .

For each vertex v of T_B , define the weight of the vertex wt_v as follows: Let J be the set of all irreducible components of $(\text{Bl}_n \mathbb{P}_R^1)_s$ corresponding to the vertices that are in T_v . Let wt_v equal the total number of irreducible horizontal divisors that occur in the divisor (f) in $\text{Bl}_n(\mathbb{P}_R^1)$, not counting the divisor $\{\infty\}$, that intersect any of the irreducible components in J . Thus, if Γ_v was obtained as the exceptional divisor in the blow-up of an intermediate iterated blow-up Z between $\text{Bl}_n(\mathbb{P}_R^1)$ and \mathbb{P}_R^1 at a smooth closed point of the special fiber $z \in Z_s$, then wt_v is exactly the number of irreducible horizontal divisors that occur in (f) that intersect Z_s at z . This in turn implies the following:

Lemma 3.6.2. *If $v \in V(T_B)$, then $\text{wt}_v \geq 2$.*

3.6.3 Local contribution and weights

Lemma 3.6.4. *For any vertex v of T_B ,*

$$d(v) = \sum_{w \in C(v)} \text{wt}_w (\text{wt}_w - 1).$$

Proof. This will once again proceed through an induction on the number of vertices of the tree. For the base case, note that the tree T_B has only one vertex if and only if all the roots of the polynomial f belong to distinct residue classes mod t and in this case $d(v) = 0$. Now for the general case. It is clear that the equality holds for the root — for a residue class

$a \in A$ such that $\text{wt}_a > 1$, the weight of the residue class as in the definition is just the weight of the subtree corresponding to the residue class. For any vertex v at depth 1 (by which we mean one of the nearest neighbours of the root) corresponding to a residue class a such that $\text{wt}_a > 1$, we first observe that the set of roots of the polynomial $g_a = \prod_{b_j \bmod t = a} (x - \frac{b_j - b_i}{t})$ corresponding to the residue class a is in natural bijection with a subset of the horizontal divisors of (f) – namely the ones corresponding to the strict transforms of the divisors $(x - b_j)$ on \mathbb{P}_R^1 for $b_j \bmod t = a$. These are the divisors that intersect the special fiber at one of the irreducible components corresponding to the vertices in this subtree with root v . These horizontal divisors are also in bijection with the horizontal divisors of the function g_a different from $\{\infty\}$ on $\text{Bl}(g_a)$. The identification of horizontal divisors of $\text{Bl}(g_a)$ and a subset of the horizontal divisors of $\text{Bl}(f)$ is compatible with the identification of the subtree of T_B with the dual graph of $\text{Bl}(g_a)_s$. By this we mean that the set of horizontal divisors intersecting the irreducible component corresponding to any given vertex match up. This tells us that the weight of a vertex of the dual graph of $\text{Bl}(g_a)_s$ equals the weight of the corresponding vertex in T_B . Since the lemma holds for the complete subtree at vertex v by induction (where the weights to the vertices of $\text{Bl}(g_a)_s$ are assigned using the horizontal divisors of $\text{Bl}(g_a)$), we are done. \square

3.7 A combinatorial description of the local terms in the Deligne discriminant

The goal of this section is to obtain explicit formulae (Theorem 3.7.22) for the local terms appearing in the Deligne discriminant in terms of the combinatorics of the tree T_B (Definition 3.7). This involves a careful analysis of the special fiber of X which we present as a series of lemmas.

Lemma 3.7.1.

- (a) *The branch locus of the double cover $\psi_1 : X \rightarrow Y$ is the set of all odd components of Y_s along with the strict transforms of the horizontal divisors $(x - b_i)$ on \mathbb{P}_R^1 .*

- (b) If Γ is an even component of Y_s and Γ' is an irreducible component of the branch locus that intersects Γ , then $\Gamma \cdot \Gamma' = 1$.

Proof.

- (a) This is clear from the construction of X as outlined in Lemma 3.1.1.
- (b) From (a), it follows that Γ does not belong to the branch locus and Γ' is either an odd component of Y_s or the strict transform of the horizontal divisor $(x - b_i)$ on \mathbb{P}_R^1 for some b_i .

Suppose Γ' is an odd component of Y_s . It follows from the construction of Y that if any two irreducible components of Y_s intersect, then they intersect transversally and there is at most one point in the intersection. This implies that $\Gamma \cdot \Gamma' = 1$.

Suppose Γ' is the strict transform of the horizontal divisor $(x - b_i)$ on \mathbb{P}_R^1 for some b_i . Let $\pi : Y \rightarrow \mathbb{P}_R^1$ be the iterated blow-up map that we obtain from the construction of Y . Since π is an iterated blow-up morphism, $\text{Pic } \mathbb{P}_R^1$ is a direct summand of $\text{Pic } Y$, with a canonical projection map $\pi_* : \text{Pic } Y \rightarrow \text{Pic } \mathbb{P}_R^1$. Let B_i denote the Weil divisor $(x - b_i)$ on \mathbb{P}_R^1 . Then $\pi_* \Gamma' = B_i$.

$$0 < \Gamma \cdot \Gamma' \leq Y_s \cdot \Gamma' = \pi^*(\mathbb{P}_R^1)_s \cdot \Gamma' = (\mathbb{P}_R^1)_s \cdot (\pi_* \Gamma') = (\mathbb{P}_R^1)_s \cdot B_i = 1.$$

This implies that $\Gamma \cdot \Gamma' = 1$. □

Lemma 3.7.2. *Let $v \in V(T_B)$ and $w \in C(v)$. Then $w(f) = v(f) + \text{wt}_w$. (Here $v(f)$ and $w(f)$ denote the valuation of f in the discrete valuation rings corresponding to the irreducible divisors Γ_v and Γ_w of $\text{Bl}_n(\mathbb{P}_R^1)$). In particular, if v is even, then w is odd if and only if wt_w is odd; if v is odd, then w is odd if and only if wt_w is even.*

Proof. The scheme $\text{Bl}_n(\mathbb{P}_R^1)$ was constructed as an iterated blow-up of \mathbb{P}_R^1 . There exist intermediate iterated blow-ups Z' and Z of \mathbb{P}_R^1 with iterated blow-up maps $\text{Bl}_n(\mathbb{P}_R^1) \rightarrow Z'$, $Z' \rightarrow Z$ and $Z \rightarrow \mathbb{P}_R^1$ such that

- (a) The scheme Z' is the blow-up of Z at a smooth closed point z of the special fiber Z_s .

- (b) The divisor $\Gamma_v \subset \text{Bl}_n(\mathbb{P}_R^1)$ is the strict transform of a vertical divisor D on Z under the morphism $\text{Bl}_n(\mathbb{P}_R^1) \rightarrow Z$.
- (c) $z \in D$.
- (d) The divisor $\Gamma_w \subset \text{Bl}_n(\mathbb{P}_R^1)$ is the strict transform of E under the morphism $\text{Bl}_n(\mathbb{P}_R^1) \rightarrow Z'$, where E denotes the exceptional divisor of $Z' \rightarrow Z$.

The valuation of f along E equals the multiplicity $\mu_z(f)$ (that is, the largest integer m such that $f \in \mathfrak{m}_{Z,z}^m - \mathfrak{m}_{Z,z}^{m+1}$). There are wt_w distinct irreducible horizontal divisors of (f) that intersect Z_s at z , and z is a smooth point on each of these divisors. This in particular implies that a uniformizer for each of the corresponding discrete valuation rings is in $\mathfrak{m}_{Z,z} - \mathfrak{m}_{Z,z}^2$. From the factorization of f and the fact that $\mathcal{O}_{Z,z}$ is a regular local ring (in particular, a unique factorization domain), one can deduce that $w(f) = \mu_z(f) = v(f) + \text{wt}_w$. This implies that $w(f)$ and wt_w have the same parity if $v(f)$ is even and have opposite parity if $v(f)$ is odd. \square

Definition. Suppose $v \in V(T_B)$. Let r_v be the total number of children of v of odd weight, and let s_v be the total number of children of v of even weight. Let l'_v equal the number of horizontal divisors of (f) different from $\{\infty\}$ passing through Γ_v and let $l_v = l'_v + r_v$. For a vertex v of T_B (or of T_Y) not equal to the root, let p_v denote the parent of v .

Since $\text{Bl}_n(\mathbb{P}_R^1)$ was obtained by iteratively blowing up a regular scheme at smooth rational points on the special fiber, all the components of its special fiber are isomorphic to \mathbb{P}_k^1 and X_s is reduced. Similarly, all the components of the special fiber of Y are also isomorphic to \mathbb{P}_k^1 , though Y_s may no longer be reduced.

Lemma 3.7.3. *Let $v \in V(T_B)$ be an even vertex. Then l_v is odd if and only if v has an odd parent. In particular, if v is the root, then l_v is even.*

Proof. Suppose $v \in V(T_B)$ is even. Then $\psi_2^{-1}(\Gamma_v)$ is a single irreducible component F of Y_s and ψ_2 is an isomorphism above a neighbourhood of Γ_v . Using Lemma 3.7.1(b) and the Riemann-Hurwitz formula, we see that the branch locus of ψ_1 has to intersect F at an even number of points. Since v is even, Lemma 3.7.1(a) and Lemma 3.7.2 imply that F intersects the branch locus at $l_v + 1$ points if v has an odd parent, and at l_v points otherwise. \square

Lemma 3.7.4. *A component of Y_s is odd if and only if it is the strict transform of an odd component of $(\text{Bl}_n(\mathbb{P}_R^1))_s$.*

Proof. The exceptional divisors that arise when we blow up $\text{Bl}_n(\mathbb{P}_R^1)$ to obtain Y are all even by Lemma 3.1.3, as every point that is blown up in $\text{Bl}_n(\mathbb{P}_R^1)$ is at the intersection of two odd components. \square

Lemma 3.7.5.

- (a) *Let $v' \in V(T_Y)$. Then $\#\varphi_1^{-1}(v') = 1$ if $\Gamma_{v'}$ intersects the branch locus of ψ_1 , and $\#\varphi_1^{-1}(v') = 2$ otherwise. If $\#\varphi_1^{-1}(v') = 2$, then both irreducible components of X_s corresponding to vertices in $\varphi_1^{-1}(v')$ are isomorphic to \mathbb{P}_k^1 .*
- (b) *Suppose $v \in V(T_B)$ is an even vertex. Then $\#\varphi^{-1}(v)$ is either 1 or 2. It is 1 if and only if $\psi_2^{-1}(\Gamma_v)$ intersects the branch locus of ψ_1 . If $\#\varphi^{-1}(v) = 2$, then both irreducible components of X_s corresponding to vertices in $\varphi^{-1}(v)$ are isomorphic to \mathbb{P}_k^1 .*
- (c) *Suppose $v \in V(T_B)$ is odd. Let $v' \in V(T_Y)$ be the vertex corresponding to the strict transform of Γ_v in Y . Let*

$$\begin{aligned} T_0 &= \{v'\}, \\ T_1 &= \{u' \in \varphi_2^{-1}(v) \mid \psi_2(\Gamma_{u'}) = \Gamma_v \cap \Gamma_u \text{ for some odd } u \in C(v)\}, \text{ and,} \\ T_2 &= \left\{ u' \in \varphi_2^{-1}(v) \left| \begin{array}{l} \psi_2(\Gamma_{u'}) = \Gamma_v \cap H \text{ for some irreducible horizontal divisor} \\ H \neq \overline{\infty} \text{ appearing in the divisor of } (f). \end{array} \right. \right\} \end{aligned}$$

Let $S_0 = \varphi_1^{-1}(T_0)$, $S_1 = \varphi_1^{-1}(T_1)$ and $S_2 = \varphi_1^{-1}(T_2)$. Then

- (i) *The sets T_0, T_1 and T_2 form a partition of $\varphi_2^{-1}(v)$. Hence $\{S_0, S_1, S_2\}$ is a partition of $\varphi^{-1}(v)$.*
- (ii) *We have that $\#S_0 = \#T_0 = 1$. Suppose $S_0 = \{\tilde{v}\}$. Then v' is odd, $m_{\tilde{v}} = 2$, and*

$$S_0 = \{v'' \in \varphi^{-1}(v) \mid \psi(\Gamma_{v''}) \text{ is not a point}\}.$$

(iii) We have that $\#S_1 = \#T_1 = s_v$. If $v'' \in S_1$, then $m_{v''} = 2$. If $u' \in T_1$, then u' is not a leaf in T_Y .

(iv) We have that $\#S_2 = \#T_2 = l'_v$. If $v'' \in S_2$, then $m_{v''} = 1$.

(v) We have that

$$T_2 = \{u' \in \varphi^{-1}(v) \mid u' \text{ is an even leaf of } T_Y\}.$$

(vi) The map φ_1 induces an isomorphism of graphs between $\varphi_2^{-1}(v)$ and $\varphi^{-1}(v)$.

(vii) The graph $\varphi_2^{-1}(v)$ is a tree with root v' and the graph $\varphi^{-1}(v)$ is a tree with root $\psi_1^{-1}(\Gamma_{v'})$.

(viii) If $v'' \in \varphi^{-1}(v)$, then $\Gamma_{v''} \cong \mathbb{P}_k^1$.

Proof.

(a) All the components of Y_s are isomorphic to \mathbb{P}_k^1 . Let $v' \in V(T_Y)$. The vertices in $\varphi_1^{-1}(v')$ are the irreducible components of $\psi_1^{-1}(\Gamma_{v'})$. If v' is even, then Lemma 3.7.1(b) tells us that if $\Gamma_{v'}$ intersects the branch locus at all, it intersects it transversally. Since ramified double covers of \mathbb{P}_k^1 are irreducible, $\psi_1^{-1}(\Gamma_{v'})$ is irreducible if $\Gamma_{v'}$ intersects the branch locus. If $\Gamma_{v'}$ does not intersect the branch locus, as \mathbb{P}_k^1 has no connected unramified double covers, we see that $\psi_1^{-1}(\Gamma_{v'})$ has two irreducible components, both of which are isomorphic to \mathbb{P}_k^1 . This implies that $\#\varphi_1^{-1}(v')$ is 1 if $\Gamma_{v'}$ intersects the branch locus of ψ_1 and is 2 otherwise.

(b) Suppose $v \in V(T_B)$ is even. Then $\psi_2^{-1}(\Gamma_v)$ is a single irreducible component F of Y_s and ψ_2 is an isomorphism above a neighbourhood of Γ_v . Let $v' \in V(T_Y)$ be such that $\Gamma_{v'} = F$. Then $\varphi_2^{-1}(v) = \{v'\}$ and $\varphi^{-1}(v) = \varphi_1^{-1}(v')$. Apply (a) to v' .

(c) (i) The component $\Gamma_{v'}$ of Y_s satisfies $\psi_2(\Gamma_{v'}) = \Gamma_v$ and it is the only component of Y_s with this property. It follows that $\varphi_2(v') = v$. The other components $\Gamma_{u'}$ of Y_s satisfying $\varphi_2(u') = v$ are the exceptional divisors of $\psi_2 : Y \rightarrow \text{Bl}_n(\mathbb{P}_R^1)$ that get mapped to a point of Γ_v that does not also lie on Γ_{p_v} . Since Y is the blow-up of $\text{Bl}_n(\mathbb{P}_R^1)$ at the finite set of points consisting of the intersection of any two odd components of the special fiber and the intersection of an odd component of the

special fiber with an irreducible horizontal divisor $H \neq \overline{\infty}$ appearing in (f), it follows that $\{T_0, T_1, T_2\}$ is a partition of $\varphi_2^{-1}(v)$. Since $\varphi^{-1}(v) = \varphi_1^{-1}(\varphi_2^{-1}(v))$, it follows that $\{S_0, S_1, S_2\}$ is a partition of $\varphi^{-1}(v)$.

- (ii) Lemma 3.7.4 tells us $\Gamma_{v'}$ is odd, and Lemma 3.7.1(a) tells us that ψ_1 is ramified over $\Gamma_{v'}$ and therefore $\psi_1^{-1}(\Gamma_{v'})$ is irreducible, and isomorphic to \mathbb{P}_k^1 . It follows that $\#S_0 = \#T_0 = 1$. Since $\psi(\Gamma_{\bar{v}}) = \psi_2(\Gamma_{v'}) = \Gamma_v$ and v is odd, Lemma 3.1.5(b) tells us that $m_{\bar{v}} = 2$.

Since $\psi(\Gamma_{\bar{v}}) = \Gamma_v$, it follows that $\psi(\Gamma_{\bar{v}})$ is not a point. Conversely, suppose $v'' \in \varphi^{-1}(v)$ and $\psi(\Gamma_{v''})$ is not a point. Since $\{T_0, T_1, T_2\}$ is a partition of $\varphi_2^{-1}(v)$ by (a) and $\psi_2(\Gamma_{u'})$ is a point for $u' \in T_1 \cup T_2$, it follows that $v'' \in \varphi_1^{-1}(T_0) = S_0$.

- (iii) For every odd $u \in C(v)$, there exists a unique exceptional curve E of the blow-up $Y \rightarrow \text{Bl}_n(\mathbb{P}_R^1)$ such that if $u' \in V(T_Y)$ is the vertex such that $\Gamma_{u'} = E$, then $u' \in \varphi_2^{-1}(v)$ and $\psi_2(\Gamma_{u'}) = \Gamma_v \cap \Gamma_u$. This shows that

$$\#T_1 = \#\text{odd children of } v = s_v \text{ (by Lemma 3.7.2 since } v \text{ is odd)}.$$

Suppose $u' \in T_1$. Let $w \in C(v)$ be an odd vertex such that $\psi_1(\Gamma_{u'}) = \Gamma_v \cap \Gamma_w$. Let $w' \in V(T_Y)$ be the vertex corresponding to the strict transform of Γ_w in Y . Then $u' \in C(v')$ and $w' \in C(u')$. In particular, u' is not a leaf. Since v' is odd, Lemma 3.7.1(a) and part (a) applied to u' imply that $\#\varphi_1^{-1}(u') = 1$. This tells us that $\#S_1 = \#T_1 = s_v$.

Suppose $v'' \in S_1$. Since v is odd and $\varphi_1(v'') \in T_1$, Lemma 3.1.5(b) implies that $m_{v''} = 2$.

- (iv) For every irreducible horizontal divisor $H \neq \overline{\infty}$ appearing in the divisor of (f) on $\text{Bl}_n(\mathbb{P}_R^1)$, there exists a unique exceptional curve E of the blow-up $Y \rightarrow \text{Bl}_n(\mathbb{P}_R^1)$ such that if $u' \in V(T_Y)$ is the vertex such that $\Gamma_{u'} = E$, then $u' \in \varphi_2^{-1}(v)$ and $\psi_2(\Gamma_{u'}) = \Gamma_v \cap H$. This shows that

$$\#T_2 = \# \left\{ \begin{array}{l} \text{irreducible horizontal divisors } H \neq \overline{\infty} \text{ appearing in} \\ (f) \text{ on } \text{Bl}_n(\mathbb{P}_R^1) \text{ that intersect } \Gamma_v \end{array} \right\} = l'_v.$$

Suppose $u' \in T_2$. Then $u' \in C(v')$. Since v' is odd, Lemma 3.7.1(a) and part (a) applied to u' imply that $\#\varphi_1^{-1}(u') = 1$. This tells us that $\#S_2 = \#T_2 = l'_v$.

Suppose $v'' \in S_2$. Then $\varphi_1(v'') \in T_2$. This implies that $\psi(\Gamma_{v''})$ is a point lying on a unique odd component of $(\text{Bl}_n(\mathbb{P}_R^1))_s$, namely Γ_v . Lemma 3.1.5(b) implies that $m_{v''} = 1$.

- (v) We already observed that v' is the unique vertex of T_0 and that it is odd (by Lemma 3.7.4). If $u' \in T_1$, then (iii) implies that u' is not a leaf. This shows

$$\{u' \in \varphi^{-1}(v) \mid u' \text{ is an even leaf of } T_Y\} \subset T_2.$$

If $u' \in T_2$, then Lemma 3.7.4 implies that u' is even. Since $\Gamma_{u'}$ is the exceptional curve that is obtained by blowing up the point of intersection of an odd component and a horizontal divisor, u' is a leaf. This shows the opposite inclusion.

- (vi) Parts (ii),(iii),(iv) imply that $\#S_0 = \#T_0$, $\#S_1 = \#T_1$ and $\#S_2 = \#T_2$. Since φ_1 is a surjection and $\{T_0, T_1, T_2\}$ is a partition of $\varphi_2^{-1}(v)$, it follows that φ_1 induces a bijection between $\varphi^{-1}(v)$ and $\varphi_2^{-1}(v)$.

If $u' \in T_1 \cup T_2$, let $u'' \in \varphi^{-1}(v)$ be the unique vertex such that $\varphi_1(u'') = u'$. Let $\{\tilde{v}\} = S_0$. If $u' \in T_1 \cup T_2$, then $u' \in C(v')$.

If $u' \in T_1 \cup T_2$, then $\Gamma_{\tilde{v}} \cap \Gamma_{u''} = \psi_1^{-1}(\Gamma_{v'} \cap \Gamma_{u'}) \neq \emptyset$. This implies that $u'' \in N(\tilde{v})$ for any $u'' \in S_1 \cup S_2$. If $\tilde{v} \in C(u'')$ for some $u'' \in S_1 \cup S_2$, then Lemma 3.5.1(a) would imply $v' \in C(u')$. Since $u' \in C(v')$, it follows that $u'' \in C(\tilde{v})$.

If $u'_1, u'_2 \in T_1 \cup T_2$, then $\Gamma_{u'_1} \cap \Gamma_{u'_2} = \emptyset$. It now follows from Lemma 3.5.1(a) and the fact that $\varphi_1(u''_1), \varphi_1(u''_2) \in T_1 \cup T_2$ that if $u''_1, u''_2 \in S_1 \cup S_2$, then $\Gamma_{u''_1} \cap \Gamma_{u''_2} = \emptyset$.

Combining the previous three paragraphs, we get that φ_1 induces an isomorphism of graphs between $\varphi^{-1}(v)$ and $\varphi_2^{-1}(v)$.

- (vii) The proof of (vi) shows that if $u' \in T_1 \cup T_2$, then $u' \in C(v')$ and that if $u'_1, u'_2 \in T_1 \cup T_2$, then $\Gamma_{u'_1}$ and $\Gamma_{u'_2}$ do not intersect. It follows that $\varphi_2^{-1}(v)$ is a tree with root v' . Since (vi) shows φ_1 induces an isomorphism of graphs between $\varphi^{-1}(v)$ and $\varphi_2^{-1}(v)$, it follows that $\varphi^{-1}(v)$ is a tree with root $\psi_1^{-1}(\Gamma_{v'})$.

(viii) We already observed in the proof of (ii) that if $\{\tilde{v}\} = S_0$, then $\Gamma_{\tilde{v}} \cong \mathbb{P}_k^1$.

Suppose $u'' \in S_1$. Let $u' = \varphi_1(u'')$. Then $u' \in T_1$. Let $w \in C(v)$ be an odd vertex such that $\psi_2(\Gamma_{u'}) = \Gamma_v \cap \Gamma_w$. Let w' be the vertex corresponding to the strict transform of Γ_w in Y . Then from the construction of Y , it follows that $N(u') = \{v', w'\}$, $u' \in C(v')$ and $w' \in C(u')$. Lemma 3.7.4 implies that v' and w' are odd and u' is even. Since $\Gamma_{u'} \cong \mathbb{P}_k^1$ and $\Gamma_{u'}$ intersects the branch locus transversally at two points (the points of intersection with $\Gamma_{v'}$ and $\Gamma_{w'}$) by Lemma 3.7.1(a,b), the Riemann-Hurwitz formula implies that $\Gamma_{u''} = \psi_1^{-1}(\Gamma_{u'}) \cong \mathbb{P}_k^1$.

Suppose $u'' \in S_2$ and $u' = \varphi_1(u'')$. Then $u' \in T_2$. Like in the previous paragraph, we can argue that $\Gamma_{u'}$ intersects the branch locus at exactly two points, corresponding to the point of intersection of $\Gamma_{u'}$ with its odd parent $\Gamma_{v'}$ and the point of intersection of $\Gamma_{u'}$ with an irreducible horizontal divisor $H \neq \overline{\infty}$ appearing in the divisor of (f) , and that these intersections are transverse. The Riemann-Hurwitz formula would once again imply $\Gamma_{u''} \cong \mathbb{P}_k^1$. Since (vi) implies that $\{S_0, S_1, S_2\}$ is a partition of $\varphi^{-1}(v)$, this completes the proof. \square

We have the following restatement of Lemma 3.1.5(b) using φ and φ_1 .

Lemma 3.7.6. *Suppose $v'' \in V(T_X)$. Then $m_{v''} = 2$ if and only if $\varphi(v'')$ is odd and $\varphi_1(v'')$ is not an even leaf. In particular, if $\varphi(v'')$ is even, then $m_{v''} = 1$.*

Proof. Lemma 3.1.5(b) tells us that $m_{v''} = 2$ if and only if $\psi(\Gamma_{v''})$ is an odd component, or, if $\psi(\Gamma_{v''}) = \Gamma_v \cap \Gamma_w$ for two odd vertices $v, w \in V(T_B)$. Let $v = \varphi(v'')$. If either of the conditions above hold, it follows from the definition of φ that the vertex v is odd. So now assume v is odd. Let $\{S_0, S_1, S_2\}$ be the partition of $\varphi^{-1}(v)$ as in Lemma 3.7.5(c). Lemma 3.7.5(c)(ii,iii,iv) imply that $m_{v''} = 2$ if and only if $v'' \notin S_2$. Lemma 3.7.5(c)(v) then tells us that $v'' \notin S_2$ if and only if $\varphi_1(v'')$ is not an even leaf.

Putting all this together, we get that $m_{v''} = 2$ if and only if $\varphi(v'')$ is odd and $\varphi_1(v'')$ is not an even leaf. \square

Lemma 3.7.7.

(a) *Suppose $u'' \in V(T_X)$ and $\psi(\Gamma_{u''})$ is a point.*

- (i) We have that $\#N(u'') = 1$ if $\psi(\Gamma_{u''})$ belongs to a unique odd component of $(\text{Bl}_n(\mathbb{P}_R^1))_s$, and $\#N(u'') = 2$ otherwise.
- (ii) If $\#N(u'') = 1$, then $\#C(u'') = 0$. If $\#N(u'') = 2$, then $\#C(u'') = 1$.
- (iii) If $w'' \in N(u'')$, then $\varphi(w'')$ is an odd vertex.
- (iv) If $w'' \in N(u'')$, then $m_{w''} = 2$.
- (b) Suppose $u'' \in V(T_X)$, $w'' \in N(u'')$, $\varphi(u'')$ is odd and $\varphi(w'')$ is even. Then $\psi(\Gamma_{u''})$ is not a point, and the component $\Gamma_{u''}$ is the inverse image under ψ_1 of the strict transform of $\Gamma_{\varphi(u'')}$.

Proof.

- (a) Let $v = \varphi(u'')$. Since $\psi(\Gamma_{u''})$ is a point, v is odd. Construct the partition S_0, S_1, S_2 of $\varphi^{-1}(v)$ as in Lemma 3.7.5(c). Since $\psi(\Gamma_{u''})$ is a point, Lemma 3.7.5(c)(ii) implies that $u'' \in S_1 \cup S_2$.

If $u'' \in S_1$, then $\psi(\Gamma_{u''}) = \Gamma_v \cap \Gamma_w$ for an odd vertex $w \in V(T_B)$. Let v', w' be the vertices in T_Y corresponding to the strict transforms of Γ_v and Γ_w respectively. Since v and w are odd, Lemma 3.7.4 tells us that v' and w' are odd. Then $N(\varphi_1(u'')) = \{v', w'\}$. By Lemma 3.7.5(a), the vertices $v', \varphi_1(u''), w'$ of T_Y each have exactly one preimage under φ_1 . Let $v'', w'' \in V(T_X)$ such that $\varphi_1(v'') = v'$ and $\varphi_1(w'') = w'$. The unique point $\Gamma_{v'} \cap \Gamma_{\varphi_1(u'')}$ has exactly one preimage under ψ_1 and therefore lies on both $\Gamma_{v''}$ and $\Gamma_{u''}$. Similarly, $\Gamma_{u''} \cap \Gamma_{w''}$ is nonempty. Lemma 3.5.1(a) now tells us that $N(u'') = \{v'', w''\}$. This implies that $\#N(u'') = 2$ and $\#C(u'') = 1$. We also have $\varphi(v'') = v$ and $\varphi(w'') = w$, and both v and w are odd vertices. Since $\varphi(v'')$ is odd and $\varphi_1(v'') = v'$ is odd, Lemma 3.7.6 tells us that $m_{v''} = 2$. Similarly, we can show $m_{w''} = 2$.

If $u'' \in S_2$, then Lemma 3.7.5(c)(v) implies that $u' := \varphi_1(u'')$ is an even leaf of T_Y . Lemma 3.7.5(c)(vii) shows u' has a parent. Let $v' = p_{\varphi_1(u'')}$ and $v = \varphi_2(v')$. Lemma 3.7.5(c)(ii, vii) imply that v' is an odd vertex corresponding to the strict transform of Γ_v in Y , and $\#\varphi_1^{-1}(v') = 1$. Let $v'' \in V(T_X)$ be such that $\varphi_1(v'') = v'$. Then

the unique point in $\Gamma_{v'} \cap \Gamma_{w'}$ has exactly one preimage under ψ_1 and this preimage is contained in $\Gamma_{v''} \cap \Gamma_{w''}$. Lemma 3.5.1 now tells us that $\#N(u'') = 1$ and $\#C(u'') = 0$. Lemma 3.7.4 implies that $\varphi(v'') = \varphi_2(v') = v$ is odd. Since $\varphi(v'') = v$ is odd and $\varphi_1(v'') = v'$ is also odd, Lemma 3.7.6 implies that $m_{v''} = 2$.

The definitions of T_1, T_2, S_1, S_2 in Lemma 3.7.5(c) show that the vertices in S_1 are exactly the ones corresponding to irreducible components of X_s whose images under ψ are contained in two odd components of $(\text{Bl}_n(\mathbb{P}_R^1))_s$ and the vertices in S_2 are the ones corresponding to irreducible components of X_s whose images under ψ are contained in exactly one odd component.

- (b) Suppose $u'' \in V(T_X)$, $w'' \in N(u'')$, $\varphi(u'')$ is odd and $\varphi(w'')$ is even. Then part (a) of this lemma tells us that $\psi(\Gamma_{u''})$ is not a point. If S_0, S_1, S_2 is the partition of $\varphi^{-1}(\varphi(u''))$ as in Lemma 3.7.5(c), then Lemma 3.7.5(c)(ii) implies that $u'' \in S_0$ since $\psi(\Gamma_{u''})$ is not a point. As S_0 has a unique vertex, and this vertex corresponds to the inverse image under ψ_1 of the strict transform of $\Gamma_{\varphi(u'')}$, we are done. \square

Lemma 3.7.8. *Let $v'', w'' \in V(T_X)$. Then $\Gamma_{v''} \cdot \Gamma_{w''} \in \{0, 1, 2\}$. Let $v = \varphi(v''), w = \varphi(w''), v' = \varphi_1(v'')$ and $w' = \varphi_1(w'')$. Then $\Gamma_{v''} \cdot \Gamma_{w''} = 2$ if and only if*

- (i) *both v and w are even,*
- (ii) *the vertices v and w are neighbours of each other, and,*
- (iii) *both $\Gamma_{v'}$ and $\Gamma_{w'}$ intersect the branch locus of ψ_1 .*

Proof. Lemma 3.1.5(b) tells us that all intersections in X_s are transverse, so the the number of points in the intersection of any two irreducible components in X_s equals their intersection number.

Let $v'', w'' \in V(T_X)$. Then $\Gamma_{v''} \cap \Gamma_{w''} \subset \psi_1^{-1}(\Gamma_{v'} \cap \Gamma_{w'})$. Since ψ_1 is finite of degree 2, any point of Y has at most two preimages under ψ_1 and therefore $\#\psi_1^{-1}(\Gamma_{v'} \cap \Gamma_{w'}) \leq 2\#\Gamma_{v'} \cap \Gamma_{w'}$. The set $\Gamma_{v'} \cap \Gamma_{w'}$ has at most one point since the dual graph T_Y of Y_s is a tree. This implies

that $\#\Gamma_{v'} \cap \Gamma_{w'} \leq 1$. Putting these together, we get

$$\begin{aligned}
\Gamma_{v''} \cdot \Gamma_{w''} &= \#\Gamma_{v''} \cap \Gamma_{w''} \\
&\leq \#\psi_1^{-1}(\Gamma_{v'} \cap \Gamma_{w'}) \\
&\leq 2 \#\Gamma_{v'} \cap \Gamma_{w'} \\
&\leq 2.
\end{aligned}$$

It follows that $\Gamma_{v''} \cdot \Gamma_{w''} \in \{0, 1, 2\}$.

Suppose that the three conditions in the lemma hold. Then conditions (i) and (ii) imply that $\Gamma_v \cap \Gamma_w$ is nonempty and consists of a single point, say b . Then the strict transforms of Γ_v and Γ_w are $\Gamma_{v'}$ and $\Gamma_{w'}$ respectively and the map ψ_2 is an isomorphism above a neighbourhood of $\Gamma_v \cup \Gamma_w$. Let y be the unique point in $\Gamma_{v'} \cap \Gamma_{w'}$. As T_Y is a tree, the point y does not lie on any other component of Y_s except $\Gamma_{v'}$ and $\Gamma_{w'}$. Lemma 3.7.4 tells us that v' and w' are even. Lemma 3.7.1(a) now tells us that the point y has two preimages under ψ_1 . Since $\Gamma_{v'}$ and $\Gamma_{w'}$ intersect the branch locus, their inverse images under ψ_1 are irreducible. This tells us $\Gamma_{v''} = \psi_1^{-1}(\Gamma_{v'})$ and $\Gamma_{w''} = \psi_1^{-1}(\Gamma_{w'})$. Then $\psi_1^{-1}(\Gamma_{v'} \cap \Gamma_{w'}) = \Gamma_{v''} \cap \Gamma_{w''}$.

$$\begin{aligned}
\Gamma_{v''} \cdot \Gamma_{w''} &= \#\Gamma_{v''} \cap \Gamma_{w''} \\
&= \#\psi_1^{-1}(\Gamma_{v'} \cap \Gamma_{w'}) \\
&= \#\psi_1^{-1}(y) \\
&= 2.
\end{aligned}$$

Now assume $\Gamma_{v''} \cdot \Gamma_{w''} = 2$. Since the intersections in X_s are transverse, the set $\Gamma_{v''} \cap \Gamma_{w''}$ has two points, say x_1 and x_2 . Then $\psi_1(x_1)$ and $\psi_1(x_2)$ must lie in $\Gamma_{v'} \cap \Gamma_{w'}$. Since any two components of Y_s cannot intersect at more than one point, this tells us that $\psi_1(x_1) = \psi_1(x_2)$. Call this point of intersection y . Since y has two preimages under ψ_1 , it cannot lie on the branch locus of ψ_1 . Lemma 3.7.1(a) tells us that v' and w' must both be even. Since $\psi(\Gamma_{v''}) = \Gamma_v$, it follows that $\psi(\Gamma_{v''})$ is not a point. Similarly $\psi(\Gamma_{w''}) = \Gamma_w$ is not a point. Either $w'' \in C(v'')$ or $v'' \in C(w'')$, and Lemma 3.5.1(b) tells us that in both cases v and w

are neighbours of each other. If $\Gamma_{v'}$ did not intersect the branch locus, then Lemma 3.7.5(a) implies that $\psi_1^{-1}(\Gamma_{v'})$ must have two disjoint irreducible components, one of which is the $\Gamma_{v''}$ we started with. Let $\tilde{v}'' \in V(T_X)$ be the other. Then there is exactly one point of $\psi_1^{-1}(y)$ in each $\Gamma_{v''}$ and $\Gamma_{\tilde{v}''}$. This contradicts the fact that $\Gamma_{v''}$ has both points of $\psi_1^{-1}(y)$. A similar argument shows that $\Gamma_{w'}$ intersects the branch locus. \square

We now make some definitions motivated by Sections 6 and 7. For $v'' \in V(T_X)$, define

$$\delta(v'') = (1 - m_{v''}) \chi(\Gamma_{v''}) + \sum_{w'' \in N(v'')} (m_{w''} - 1) \Gamma_{v''} \cdot \Gamma_{w''} + \sum_{w'' \in C(v'')} \Gamma_{v''} \cdot \Gamma_{w''}.$$

Let $v \in V(T_B)$. Define

$$D(v) = \sum_{v'' \in \varphi^{-1}(v)} \delta(v'').$$

3.7.9 Computation of $D(v)$ for an even vertex v

Suppose $v \in V(T_B)$ is an even vertex. We define $D_0(v), D_1(v), D_2(v)$ as follows.

$$\begin{aligned} D_0(v) &= \sum_{v'' \in \varphi^{-1}(v)} (1 - m_{v''}) \chi(\Gamma_{v''}). \\ D_1(v) &= \sum_{v'' \in \varphi^{-1}(v)} \sum_{w'' \in N(v'')} (m_{w''} - 1) \Gamma_{v''} \cdot \Gamma_{w''}. \\ D_2(v) &= \sum_{v'' \in \varphi^{-1}(v)} \sum_{w'' \in C(v'')} \Gamma_{v''} \cdot \Gamma_{w''} \end{aligned}$$

Then $D(v) = D_0(v) + D_1(v) + D_2(v)$. We will now compute $D_i(v)$ for each $i \in \{0, 1, 2\}$ in terms of l_v, r_v and s_v .

Lemma 3.7.10. *Suppose $v \in V(T_B)$ is even. Then $D_0(v) = 0$.*

Proof. Suppose v is an even vertex. Lemma 3.7.6 implies that $m_{v''} = 1$ for every $v'' \in \varphi^{-1}(v)$ and therefore,

$$D_0(v) = \sum_{v'' \in \varphi^{-1}(v)} (1 - m_{v''}) \chi(\Gamma_{v''}) = 0. \quad \square$$

Lemma 3.7.11. *Suppose $v \in V(T_B)$ is even. Let $v'' \in \varphi^{-1}(v)$ and $w'' \in N(v'')$. Let $v' = \varphi_1(v'')$, $w' = \varphi_1(w'')$ and $w = \varphi(w'')$.*

- (a) *The vertex v' is even and $\varphi_2^{-1}(v) = \{v'\}$.*
- (b) *The multiplicity $m_{w''} = 2$ if and only if w is odd.*
- (c) *If $v'' \in C(w'')$, then $v \in C(w)$. If $w'' \in C(v'')$, then $w \in C(v)$. In particular, $w \in N(v)$.*
- (d) *If $r_v = 0$ and l_v is even, then every neighbour of v is even.*
- (e) *The branch locus of ψ_1 intersects $\Gamma_{v'}$ at $l_v + (l_v \bmod 2)$ points, and all these intersections are transverse.*
- (f) *If $l_v = 0$, then $\Gamma_{v'}$ does not intersect the branch locus of ψ_1 and $\#\varphi^{-1}(v) = 2$.*
- (g) *If $l_v \neq 0$, then $\Gamma_{v'}$ intersects the branch locus of ψ_1 , $\#\varphi^{-1}(v) = 1$ and $\varphi^{-1}(v) = \{v''\}$.*
- (h) *If w is odd, then $\Gamma_{v''} \cdot \Gamma_{w''} = 1$.*
- (i) *Suppose $u \in N(v)$ is odd. Then there exists a unique $u'' \in \varphi^{-1}(u)$ such that $u'' \in N(v'')$. If $u \in C(v)$, then $u'' \in C(v'')$. If $v \in C(u)$, then $v'' \in C(u'')$.*
- (j) *Suppose $l_v \neq 0$, $w'' \in C(v'')$ and w is even. Then $\#\varphi^{-1}(w) \in \{1, 2\}$. If $\#\varphi^{-1}(w) = 1$, then $\Gamma_{v''} \cdot \Gamma_{w''} = 2$. If $\#\varphi^{-1}(w) = 2$, then $\Gamma_{v''} \cdot \Gamma_{w''} = 1$.*
- (k) *Suppose $l_v \neq 0$ and $u \in C(v)$ is even. If $u'' \in \varphi^{-1}(u)$, then $u'' \in C(v'')$.*
- (l) *If $l_v = 0$, then $\Gamma_{v''} \cdot \Gamma_{w''} = 1$.*
- (m) *Suppose $l_v = 0$ and $u \in C(v)$ is even. If $\varphi^{-1}(u) = \{u''\}$, then $u'' \in C(v'')$. If $\varphi^{-1}(u) = \{u''_1, u''_2\}$, then, after possibly interchanging u''_1 and u''_2 , we have that $u''_1 \in C(v'')$ and $\Gamma_{v''} \cdot \Gamma_{u''_2} = 0$.*

Proof.

- (a) Since $\varphi_2(v') = \varphi(v'') = v$ and v is even, Lemma 3.7.4 tells us that v' is even.

(b) First assume w is odd. Since v' is even, Lemma 3.7.7(b) implies that $\Gamma_{w''}$ is the preimage under ψ_1 of the strict transform of Γ_w in Y . In particular, Lemma 3.7.4 tells us that w' is odd, and therefore not an even leaf. Lemma 3.7.6 applied to w'' then implies that $m_{w''} = 2$.

Conversely, assume $m_{w''} = 2$. Lemma 3.7.6 applied to w'' implies that w is odd.

(c) If w is odd, since v is even, Lemma 3.7.7(b) tells us that $\psi(\Gamma_{w''})$ is not a point. If w is even, then $\psi(\Gamma_{w''})$ is not a point. Since v is even, $\psi(\Gamma_{v''})$ is not a point. Since $w'' \in N(v'')$, either $v'' \in C(w'')$ or $w'' \in C(v'')$. Since both $\psi(\Gamma_{v''})$ and $\psi(\Gamma_{w''})$ are not points, Lemma 3.5.1(b) tells us that in the first case $v \in C(w)$ and in the second case $w \in C(v)$. Both of these imply $w \in N(v)$.

(d) Suppose $r_v = 0$ and l_v is even. Since v is even and $r_v = 0$, Lemma 3.7.2 implies that every child of v is even. Since l_v is even, Lemma 3.7.3 implies that v does not have an odd parent. Therefore every neighbour of v is even.

(e) Lemma 3.7.1(a) and Lemma 3.7.4 tell us that $\Gamma_{v'}$ does not belong to the branch locus since $\varphi_2(v') = v$, which is even. Lemma 3.7.1(b) tells us that any component of the branch locus that intersects $\Gamma_{v'}$, intersects it transversally.

- Lemma 3.7.1(a) tells us that the components of the branch locus are the odd components of Y_s and the irreducible horizontal divisors appearing in (f) different from $\overline{\infty}$.
- Lemma 3.7.4 tells us that the odd components of Y_s are the strict transforms of odd components of $(\text{Bl}_n(\mathbb{P}_R^1))_s$.
- Since v is even, the map ψ_2 induces an isomorphism above a neighbourhood of Γ_v .

Therefore, the number of components of the branch locus intersecting $\Gamma_{v'}$ is the number of odd neighbours of v added to the number of horizontal divisors different from $\overline{\infty}$ appearing in the divisor of (f) that intersect Γ_v . The latter number is l'_v . Since v is even, Lemma 3.7.2 tells us that the number of odd children of v is r_v . Lemma 3.7.3 tells us that

the number of odd parents of v is $(l_v \bmod 2)$. Since $l'_v + r_v + (l_v \bmod 2) = l_v + (l_v \bmod 2)$, the branch locus intersects $\Gamma_{v'}$ at $l_v + (l_v \bmod 2)$ points.

- (f) Suppose $l_v = 0$. Then $l_v + (l_v \bmod 2) = 0$. Part (e) tell us that $\Gamma_{v'}$ does not intersect the branch locus of ψ_1 . Since v is even, Lemma 3.7.5(b) implies that $\#\varphi^{-1}(v) = 2$.
- (g) Suppose $l_v \neq 0$. Then $l_v + (l_v \bmod 2) \neq 0$. Part (e) tells us that $\Gamma_{v'}$ intersects the branch locus of ψ_1 . Lemma 3.7.5(b) then implies that $\#\varphi^{-1}(v) = 1$. It follows that $\varphi^{-1}(v) = \{v''\}$.
- (h) Suppose w is odd. Since w is odd, Lemma 3.7.8 tells us that $\Gamma_{v''} \cdot \Gamma_{w''} < 2$. On the other hand, since $w'' \in N(v'')$, it follows that $\Gamma_{v''} \cdot \Gamma_{w''} \geq 1$.
- (i) Suppose $u \in N(v)$ is odd. Let u' be the vertex corresponding to the strict transform of Γ_u in Y . As $u \in N(v)$ and ψ_2 is an isomorphism above a neighbourhood of Γ_v , it follows that $u' \in N(v')$. In fact, this shows that if $u \in C(v)$, then $u' \in C(v')$; if $v \in C(u)$, then $v' \in C(u')$.

Lemma 3.7.4 shows that u' is odd. Lemma 3.7.1(a) and Lemma 3.7.5(a) applied to u' show that there is a unique u'' in $V(T_X)$ such that $\varphi_1(u'') = u'$. Part (a) tells us that v' is even and $\varphi_2^{-1}(v) = \{v'\}$. Since $\Gamma_{v'}$ intersects $\Gamma_{u'}$ and u' is odd, Lemma 3.7.1(a) and Lemma 3.7.5(a) applied to the even vertex v' tell us that $\varphi^{-1}(v) = \varphi_1^{-1}(v') = \{v''\}$. Since $\psi_1^{-1}(\Gamma_{u'}) = \Gamma_{u''}$ and $\psi_1^{-1}(\Gamma_{v'}) = \Gamma_{v''}$, it follows that $\Gamma_{u''} \cap \Gamma_{v''} = \psi_1^{-1}(\Gamma_{u'} \cap \Gamma_{v'})$. Since ψ_1 is surjective and $\Gamma_{u'} \cap \Gamma_{v'}$ is nonempty, it follows that $u'' \in N(v'')$. We also have $\varphi(u'') = \varphi_2(u') = u$. This proves the existence of $u'' \in \varphi^{-1}(u)$ such that $u'' \in N(v'')$.

Suppose that we are given $u'' \in \varphi^{-1}(u)$ such that $u'' \in N(v'')$. Since v is even and u is odd, Lemma 3.7.7(b) forces u'' to be the inverse image under ψ_1 of the strict transform of Γ_u in Y . This proves uniqueness.

Lemma 3.5.1(a) tells us that if $v'' \in C(u'')$, then $v' \in C(u')$. If $u \in C(v)$, then $u' \in C(v')$ and therefore $u'' \in C(v'')$. Similarly, one can show that if $v \in C(u)$, then $v'' \in C(u'')$.

- (j) Part (g) tells us that $\Gamma_{v'}$ intersects the branch locus of ψ_1 . Since w is even, Lemma 3.7.5(b) implies that $\#\varphi^{-1}(w) \in \{1, 2\}$. Since v and w are even, $\#\psi^{-1}(\Gamma_v \cap \Gamma_w) = 2$. Since

$w'' \in C(v'')$, Lemma 3.7.8 tells us that $1 \leq \Gamma_{v''} \cdot \Gamma_{w''} \leq 2$. We have that v and w are even, $w \in C(v)$ (by (c)) and that $\Gamma_{v'}$ intersects the branch locus; thus, Lemma 3.7.8 implies that $\Gamma_{v''} \cdot \Gamma_{w''} = 2$ if $\Gamma_{w'}$ intersects the branch locus, and $\Gamma_{v''} \cdot \Gamma_{w''} = 1$ if it does not. Lemma 3.7.5(b) applied to w tells us that this can be restated as follows: If $\#\varphi^{-1}(w) = 1$, then $\Gamma_{v''} \cdot \Gamma_{w''} = 2$; if $\#\varphi^{-1}(w) = 2$, then $\Gamma_{v''} \cdot \Gamma_{w''} = 1$.

(k) Let $u' \in V(T_Y)$ be the vertex corresponding to the strict transform of Γ_u in Y . Let $u'' \in \varphi^{-1}(u)$.

- Part (g) tells us that $\Gamma_{v'}$ intersects the branch locus of ψ_1 and $\varphi^{-1}(v) = \{v''\}$. Therefore $\psi_1^{-1}(\Gamma_{v'}) = \Gamma_{v''}$.
- Since ψ_2 is an isomorphism above a neighbourhood of Γ_v , we have that $u' \in C(v')$. In particular, $\Gamma_{u'} \cap \Gamma_{v'} \neq \emptyset$.
- The map ψ_1 restricts to a surjection $\Gamma_{u''} \rightarrow \Gamma_{u'}$.

These three facts together imply that $\Gamma_{u''} \cap \Gamma_{v''}$ is not empty. In particular, $u'' \in N(v'')$. If $v'' \in C(u'')$, then Lemma 3.5.1(a) would imply $v' \in C(u')$. Since $u' \in C(v')$, Lemma 3.5.1(a) implies that $u'' \in C(v'')$.

(l) Suppose $l_v = 0$. Part (f) tells us that $\Gamma_{v'}$ does not intersect the branch locus. Lemma 3.7.8 applied to the pair v'', w'' tells us $\Gamma_{v''} \cdot \Gamma_{w''} < 2$. On the other hand, since $w'' \in N(v'')$, we have that $\Gamma_{v''} \cdot \Gamma_{w''} \geq 1$. Therefore, $\Gamma_{v''} \cdot \Gamma_{w''} = 1$.

(m) Let $u' \in V(T_Y)$ be the vertex corresponding to the strict transform of Γ_u in Y . Since ψ_2 is an isomorphism above a neighbourhood of Γ_v , we get that $u' \in C(v')$.

Suppose $\varphi^{-1}(u) = \{u''\}$. Since $\psi_1^{-1}(\Gamma_{u'}) = \Gamma_{u''}$ and ψ_1 restricts to a surjection $\Gamma_{v''} \rightarrow \Gamma_{v'}$, an appropriate modification of the argument in part(j) tells us that $u'' \in C(v'')$.

Suppose $\varphi^{-1}(u) = \{u''_1, u''_2\}$. Then Lemma 3.7.5(a) implies that $\Gamma_{u'}$ does not intersect the branch locus. Part (f) implies that $\Gamma_{v'}$ does not intersect the branch locus. This implies that the map ψ_1 is étale above a neighbourhood of $\Gamma_{v'} \cup \Gamma_{u'}$. Since \mathbb{P}_k^1 has no connected étale covers, this implies that $\psi_1^{-1}(\Gamma_{v'} \cup \Gamma_{u'})$ has two connected components, each of which maps isomorphically on to $\Gamma_{v'} \cup \Gamma_{u'}$ via ψ_1 . This finishes the proof. \square

Lemma 3.7.12. *Suppose $v \in V(T_B)$ is even. Then $D_1(v) = (l_v \bmod 2) + r_v$. (Here and subsequently $l_v \bmod 2$ is an integer in $\{0, 1\}$. It is 0 if l_v is even and 1 if l_v is odd.)*

Proof. Suppose $v \in V(T_B)$ is even. We break up the computation of $D_1(v)$ into two cases:

Case 1: $l_v = 0$

In this case,

$$\begin{aligned}
D_1(v) &= \sum_{v'' \in \varphi^{-1}(v)} \sum_{w'' \in N(v'')} (m_{w''} - 1) \Gamma_{v''} \cdot \Gamma_{w''} \\
&= \sum_{v'' \in \varphi^{-1}(v)} \sum_{\substack{w'' \in N(v'') \\ \varphi(w'') \text{ even}}} (m_{w''} - 1) \Gamma_{v''} \cdot \Gamma_{w''} \quad (\text{by Lemma 3.7.11(d) since } r_v = l_v = 0) \\
&= \sum_{v'' \in \varphi^{-1}(v)} \sum_{\substack{w'' \in N(v'') \\ \varphi(w'') \text{ even}}} (1 - 1) \Gamma_{v''} \cdot \Gamma_{w''} \quad (\text{by Lemma 3.7.11(b)}) \\
&= 0 \\
&= (l_v \bmod 2) + r_v \quad (\text{since } l'_v \text{ and } r_v \text{ are nonnegative, } r_v = 0).
\end{aligned}$$

Case 2: $l_v \neq 0$

In this case, Lemma 3.7.11(g) implies that $\#\varphi^{-1}(v) = 1$. Let $\varphi^{-1}(v) = \{v''\}$. Then

$$\begin{aligned}
D_1(v) &= \sum_{\tilde{v}'' \in \varphi^{-1}(v)} \sum_{w'' \in N(\tilde{v}'')} (m_{w''} - 1) \Gamma_{\tilde{v}''} \Gamma_{w''} \\
&= \sum_{w'' \in N(v'')} (m_{w''} - 1) \Gamma_{v''} \Gamma_{w''} \\
&= \sum_{\substack{w'' \in N(v'') \\ \varphi(w'') \text{ odd}}} (m_{w''} - 1) \Gamma_{v''} \Gamma_{w''} + \sum_{\substack{w'' \in N(v'') \\ \varphi(w'') \text{ even}}} (m_{w''} - 1) \Gamma_{v''} \Gamma_{w''} \\
&= \sum_{\substack{w'' \in N(v'') \\ \varphi(w'') \text{ odd}}} (2 - 1) \Gamma_{v''} \Gamma_{w''} + \sum_{\substack{w'' \in N(v'') \\ \varphi(w'') \text{ even}}} (1 - 1) \Gamma_{v''} \Gamma_{w''} \quad (\text{by Lemma 3.7.11(b)}) \\
&= \sum_{\substack{w'' \in N(v'') \\ \varphi(w'') \text{ odd}}} 1 \quad (\text{by Lemma 3.7.11(h)}) \\
&= \sum_{\substack{w \in N(v) \\ w \text{ odd}}} \sum_{\substack{w'' \in N(v'') \\ \varphi(w'')=w}} 1 \quad (\text{by Lemma 3.7.11(c)}) \\
&= \sum_{\substack{w \in N(v) \\ w \text{ odd}}} 1 \quad (\text{by Lemma 3.7.11(i) with } u = w) \\
&= \begin{cases} 1 + \sum_{\substack{w \in C(v) \\ w \text{ odd}}} 1 & \text{if } v \text{ has an odd parent} \\ \sum_{\substack{w \in C(v) \\ w \text{ odd}}} 1 & \text{otherwise} \end{cases} \\
&= (l_v \bmod 2) + r_v \quad (\text{by Lemma 3.7.3 and Lemma 3.7.2 since } v \text{ is even}). \quad \square
\end{aligned}$$

Lemma 3.7.13. *Suppose $v \in V(T_B)$ is even. Then $D_2(v) = r_v + 2s_v$.*

Proof. We break up the computation of $D_2(v)$ into two cases:

Case 1: $l_v = 0$

In this case, Lemma 3.7.11(f) tells us that $\#\varphi^{-1}(v) = 2$. Since l'_v and r_v are nonnegative, $r_v = 0$. Then

$$\begin{aligned}
D_2(v) &= \sum_{v'' \in \varphi^{-1}(v)} \sum_{w'' \in C(v'')} \Gamma_{v''} \cdot \Gamma_{w''} \\
&= \sum_{\substack{w \in C(v) \\ w \text{ even}}} \sum_{v'' \in \varphi^{-1}(v)} \sum_{\substack{w'' \in C(v'') \\ \varphi(w'')=w}} \Gamma_{v''} \cdot \Gamma_{w''} \\
&\quad \text{(since Lemma 3.7.11(c,d) imply that } \varphi(w'') \in C(v) \text{ and is even)} \\
&= \sum_{\substack{w \in C(v) \\ w \text{ even}}} 2 \\
&\quad \text{(by Lemma 3.7.11(1,m) since Lemma 3.7.5(b) implies that } \#\varphi^{-1}(w) \in \{1, 2\}) \\
&= r_v + 2s_v \quad \text{(by Lemma 3.7.2 since } v \text{ is even and } r_v = 0).
\end{aligned}$$

Case 2: $l_v \neq 0$

In this case, Lemma 3.7.11(g) implies that $\#\varphi^{-1}(v) = 1$. Let $\{v''\} = \varphi^{-1}(v)$. Then

$$\begin{aligned}
D_2(v) &= \sum_{w'' \in C(v'')} \Gamma_{v''} \cdot \Gamma_{w''} \\
&= \sum_{\substack{w'' \in C(v'') \\ \varphi(w'') \text{ odd}}} 1 + \sum_{\substack{w'' \in C(v'') \\ \varphi(w'') \text{ even}}} \Gamma_{v''} \cdot \Gamma_{w''} \quad \text{(by Lemma 3.7.11(h))} \\
&= \sum_{\substack{w \in C(v) \\ w \text{ odd}}} \sum_{\substack{w'' \in C(v'') \\ \varphi(w'')=w}} 1 + \sum_{\substack{w \in C(v) \\ w \text{ even}}} \sum_{\substack{w'' \in C(v'') \\ \varphi(w'')=w}} \Gamma_{v''} \cdot \Gamma_{w''} \quad \text{(by Lemma 3.7.11(c))} \\
&= \sum_{\substack{w \in C(v) \\ w \text{ odd}}} 1 + \sum_{\substack{w \in C(v) \\ w \text{ even}}} 2 \\
&\quad \text{(by Lemma 3.7.11(i), (k) with } u = w \text{ and Lemma 3.7.11(j))} \\
&= r_v + 2s_v \quad \text{(by Lemma 3.7.2 since } v \text{ is even).} \quad \square
\end{aligned}$$

Lemma 3.7.14. *Suppose $v \in V(T_B)$ is even. Then*

$$D(v) = (l_v \bmod 2) + 2r_v + 2s_v.$$

Proof. Combine Lemmas 3.7.10, 3.7.12 and 3.7.13. □

3.7.15 Computation of $D(v)$ for an odd vertex v

Suppose $v \in V(T_B)$ is odd. Let $S_0(v), S_1(v), S_2(v)$ denote the partition of $\varphi^{-1}(v)$ constructed in Lemma 3.7.5(c).

Lemma 3.7.16. *Suppose $v \in V(T_B)$ is odd. Let $v'' \in S_0(v), w'' \in N(v''), v' = \varphi_1(v'')$ and $w = \varphi(w'')$.*

(a) *The component $\Gamma_{v'}$ is the strict transform of Γ_v in Y and v' is odd. The image $\psi(\Gamma_{v''})$ is not a point.*

(b) *We have that*

$$\{w'' \in C(v'') \mid m_{w''} = 2\} = S_1(v).$$

We also have that $\#S_1(v) = s_v$.

(c) *If $v'' \in C(w'')$ and $m_{w''} = 2$, then $w = p_v$ and w is odd.*

(d) *If p_v is odd, there exists a unique $u'' \in \varphi^{-1}(p_v)$ such that $v'' \in C(u'')$.*

(e) *The map φ induces a bijection between the sets $\{w'' \in C(v'') - S_2(v) \mid m_{w''} = 1\}$ and $\{w \in C(v) \mid w \text{ is even}\}$.*

(f) *We have that $\Gamma_{v''} \cdot \Gamma_{w''} = 1$.*

Proof.

(a) Since $v'' \in S_0(v)$ and $v' = \varphi_1(v'')$, it follows from Lemma 3.7.5(c)(ii) that $\Gamma_{v'}$ is the strict transform of Γ_v in Y . Since $\varphi_1(v'') = v'$, it follows that $\psi(\Gamma_{v''}) = \psi_2(\Gamma_{v'}) = \Gamma_v$. Therefore $\psi(\Gamma_{v''})$ is not a point. Lemma 3.7.5(c)(ii) also implies that v' is odd.

(b) Suppose $w'' \in C(v'')$ and $m_{w''} = 2$. Let $w' = \varphi_1(w'')$. Since $w'' \in C(v'')$, Lemma 3.5.1(a) implies that $w' \in C(v')$. Since odd components of Y do not intersect and (a) implies that v' is odd, w' is even. Since $m_{w''} = 2$, Lemma 3.7.6 tells us that w is odd and w' is not an even leaf of T_Y . Let T_0, T_1, T_2 be the partition of $\varphi_2^{-1}(w)$ as in Lemma 3.7.5(c).

Since w' is even, Lemma 3.7.4 tells us that $w' \notin T_0$. Since w' is not an even leaf of T_Y , the displayed equation in the proof of Lemma 3.7.6 shows that $w' \in T_1$. Since $w' \in T_1$, Lemma 3.7.5(c)(vii) shows that $p_{w'} \in T_0$. Since $w' \in C(v')$, it follows that $v' = p_{w'} \in T_0$ and therefore $\varphi_2(v') \in \varphi_2(T_0) = \{w\}$, which implies that $v = w$. Finally, $w'' \in \varphi_1^{-1}(w') \subseteq \varphi_1^{-1}(T_1) = S_1(v)$.

Conversely, suppose $w'' \in S_1(v)$. Since $v'' \in S_0(v)$, Lemma 3.7.5(c)(i,vii) show that $w'' \in C(v'')$ and $m_{w''} = 2$. Lemma 3.7.5(c)(iii) implies that $\#S_1(v) = s_v$.

(c) Suppose $v'' \in C(w'')$ and $m_{w''} = 2$. Since $v'' \in C(w'')$ and $\psi(\Gamma_{v''})$ is not a point by (a), Lemma 3.5.1(b) tells us that $v \in C(w)$. Since $m_{w''} = 2$, Lemma 3.7.6 tells us that w is odd.

(d) Suppose p_v is odd. Let $u = p_v$. Let T_0, T_1, T_2 be the partition of $\varphi_2^{-1}(u)$ as in Lemma 3.7.5(c). Let $u' \in T_1$ be the unique vertex such that $\psi_2(\Gamma_{u'}) = \Gamma_u \cap \Gamma_v$. Since (a) implies that $\Gamma_{v'}$ is the strict transform of Γ_v in Y , the proof of Lemma 3.7.5(c)(iii) in the case of the odd vertex u shows that $v' \in C(u')$. Lemma 3.7.5(c) applied to the odd vertex u tells us that φ_1 induces a bijection between $\varphi^{-1}(u)$ and $\varphi_2^{-1}(u)$. This shows that there exists a unique $u'' \in V(T_X)$ such that $\varphi_1(u'') = u'$. Since v' is odd by (a), Lemma 3.7.5(a) and Lemma 3.7.1(a) then imply that $\psi_1^{-1}(\Gamma_{v'}) = \Gamma_{v''}$. Since $\varphi_1^{-1}(u') = \{u''\}$, it follows that $\psi_1^{-1}(\Gamma_{u'}) = \Gamma_{u''}$. Therefore, $\Gamma_{u''} \cap \Gamma_{v''} = \psi_1^{-1}(\Gamma_{u'} \cap \Gamma_{v'}) \neq \emptyset$. This implies that either $u'' \in C(v'')$, or $v'' \in C(u'')$. Since $v' \in C(u')$, Lemma 3.5.1(a) implies that $v'' \in C(u'')$. This proves the existence of u'' .

Suppose $u'' \in \varphi^{-1}(u)$ be such that $v'' \in C(u'')$. Then Lemma 3.5.1(a) implies that $\varphi_1(u'') = p_{v'}$. Since v' is odd (by (a)) and $\Gamma_{p_{v'}}$ intersects $\Gamma_{v'}$, Lemma 3.7.1(a) and Lemma 3.7.5(a) imply that $\#\varphi_1^{-1}(p_{v'}) = 1$. This proves uniqueness of $u'' \in \varphi^{-1}(u)$ such that $v'' \in C(u'')$.

(e) Suppose $w'' \in C(v'') - S_2(v)$ and $m_{w''} = 1$. We will first show $\psi(\Gamma_{w''})$ is not a point. Suppose $\psi(\Gamma_{w''})$ is a point. Since $w'' \in C(v'')$, Lemma 3.5.1(b) implies that $w = \varphi(w'') = \varphi(v'') = v$. Since $m_{w''} = 1$, Lemma 3.7.5(c)(i,ii,iii) then imply that $w'' \in S_2(v)$, which is a contradiction. Therefore, $\psi(\Gamma_{w''})$ is not a point. Lemma 3.5.1(a) then implies that

$w \in C(v)$.

Suppose w is odd. Let $w' = \varphi_1(w'')$. Since $\psi(\Gamma_{w''})$ is not a point, $w'' \in S_0(w)$. Part (a) applied to w'' implies that w' is odd. Part (a) implies that v' is odd. Since $w'' \in C(v'')$, Lemma 3.5.1(a) implies that $w' \in C(v')$. This is a contradiction since odd components of Y cannot intersect. Therefore w is even. This shows one inclusion.

Now suppose $u \in C(v)$ is even. Let $u' \in V(T_Y)$ be the vertex corresponding to the strict transform of Γ_u in Y . Part (a) implies that v' is the vertex corresponding to the strict transform of Γ_v and v' is odd. Lemma 3.7.4 implies that u' is even. This in turn implies that ψ_2 is an isomorphism above a neighbourhood of Γ_u , and therefore $u' \in C(v')$. Since v' is odd and $u' \in C(v')$, Lemma 3.7.5(b) applied to u implies that $\#\varphi^{-1}(u) = 1$. Let $\varphi^{-1}(u) = \varphi_1^{-1}(u') = \{u''\}$. Since $\psi_1^{-1}(\Gamma_{v'}) = \Gamma_{v''}$ and $\psi_1^{-1}(\Gamma_{u'}) = \Gamma_{u''}$, it follows that $\Gamma_{v''} \cap \Gamma_{u''} = \psi_1^{-1}(\Gamma_{v'} \cap \Gamma_{u'})$ is not empty. In particular, $u'' \in N(v'')$. Since $\varphi_1(u'') = u' \in C(v') = C(\varphi_1(v''))$, Lemma 3.5.1(a) implies that $u'' \in C(v'')$. This shows the opposite inclusion.

(f) Since $\varphi(v'') = v$ is odd, Lemma 3.7.8 tells us that $\Gamma_{v''} \cdot \Gamma_{w''} < 2$. On the other hand, since $w'' \in N(v'')$, we have that $\Gamma_{v''} \cdot \Gamma_{w''} \geq 1$. \square

We will now compute $\sum_{v'' \in S_i(v)} \delta(v'')$ for each $i \in \{0, 1, 2\}$, in terms of l_v, r_v and s_v .

Lemma 3.7.17. *Suppose $v \in V(T_B)$ is odd. Then*

$$\sum_{v'' \in S_0(v)} \delta(v'') = \begin{cases} -2 + l_v + 2s_v & \text{if } p_v \text{ is even} \\ -1 + l_v + 2s_v & \text{if } p_v \text{ is odd.} \end{cases}$$

Proof. Let $S_0 = S_0(v), S_1 = S_1(v)$ and $S_2 = S_2(v)$. Lemma 3.7.5(c)(ii) implies that $\#S_0 = 1$. Let $\tilde{v} \in S_0$. Since S_0 consists of a single vertex \tilde{v} ,

$$\sum_{v'' \in S_0} \delta(v'') = \delta(\tilde{v}) = (1 - m_{\tilde{v}}) \chi(\Gamma_{\tilde{v}}) + \sum_{w'' \in N(\tilde{v})} (m_{w''} - 1) \Gamma_{\tilde{v}} \cdot \Gamma_{w''} + \sum_{w'' \in C(\tilde{v})} \Gamma_{\tilde{v}} \cdot \Gamma_{w''}.$$

We will compute each of the three terms in this sum separately.

By Lemma 3.7.5(c)(ii),

$$(1 - m_{\bar{v}}) \chi(\Gamma_{\bar{v}}) = (1 - m_{\bar{v}}) \chi(\mathbb{P}_k^1) = (1 - 2)(2) = -2.$$

Now

$$\begin{aligned} \sum_{w'' \in N(\bar{v})} (m_{w''} - 1) \Gamma_{\bar{v}} \cdot \Gamma_{w''} &= \sum_{w'' \in N(\bar{v})} (m_{w''} - 1) \quad (\text{by Lemma 3.7.16(f)}) \\ &= \sum_{w'' \in S_1} (2 - 1) + \sum_{w'' \in C(\bar{v}) - S_1} (1 - 1) + \sum_{\substack{w'' \in V(T_X) \\ \bar{v} \in C(w'')}} (m_{w''} - 1) \\ &\hspace{15em} (\text{by Lemma 3.7.16(b)}) \\ &= s_v + \sum_{\substack{w'' \in V(T_X) \\ \bar{v} \in C(w'')}} (m_{w''} - 1) \quad (\text{by Lemma 3.7.16(b)}) \\ &= s_v + \sum_{\substack{w'' \in \varphi^{-1}(p_v) \\ \bar{v} \in C(w'')}} (m_{w''} - 1) \quad (\text{by Lemma 3.7.16(c)}) \\ &\hspace{15em} \varphi(w'') \text{ is odd} \\ &= \begin{cases} s_v & \text{if } p_v \text{ is even} \\ s_v + 1 & \text{if } p_v \text{ is odd} \end{cases} \quad (\text{by Lemma 3.7.16(d)}). \end{aligned}$$

Now

$$\begin{aligned} \sum_{w'' \in C(\bar{v})} \Gamma_{\bar{v}} \cdot \Gamma_{w''} &= \sum_{w'' \in C(\bar{v})} 1 \quad (\text{by Lemma 3.7.16(f)}) \\ &= \sum_{\substack{w'' \in C(\bar{v}) \\ m_{w''}=2}} 1 + \sum_{w'' \in S_2} 1 + \sum_{\substack{w'' \in C(\bar{v}) - S_2 \\ m_{w''}=1}} 1 \\ &\hspace{15em} (\text{by Lemmas 3.1.5(b), 3.7.5(c)(i,iv,vii)}) \\ &= s_v + l'_v + \sum_{\substack{w'' \in C(\bar{v}) - S_2 \\ m_{w''}=1}} 1 \quad (\text{by Lemma 3.7.16(b) and Lemma 3.7.5(c)(iv)}) \\ &= s_v + l'_v + r_v \quad (\text{by Lemma 3.7.2 since } v \text{ is odd, and by Lemma 3.7.16(e)}) \\ &= s_v + l_v. \end{aligned}$$

Adding the three previous equalities gives us

$$\sum_{v'' \in S_0(v)} \delta(v'') = \delta(\tilde{v}) = \begin{cases} -2 + l_v + 2s_v & \text{if } p_v \text{ is even} \\ -1 + l_v + 2s_v & \text{if } p_v \text{ is odd.} \end{cases} \quad \square$$

Lemma 3.7.18. *Suppose $v \in V(T_B)$ is odd. Then*

$$\sum_{v'' \in S_1(v)} \delta(v'') = s_v.$$

Proof. Let $S_1 = S_1(v)$. Let \tilde{v} be the unique element of $S_0(v)$. Suppose $v'' \in S_1$. Lemma 3.7.5(c)(iii,viii) tells us that $\Gamma_{v''} \cong \mathbb{P}_k^1$, $v'' \in C(\tilde{v})$, $m_{v''} = 2$ and $\psi(\Gamma_{v''}) = \Gamma_v \cap \Gamma_u$ for an odd $u \in C(v)$.

Since $\psi(\Gamma_{v''})$ is a point that belongs to two odd components of $(\text{Bl}_n(\mathbb{P}_R^1))_s$, Lemma 3.7.7(a)(i,ii) tell us that $\#N(v'') = 2$ and $\#C(v'') = 1$. Suppose $w'' \in N(v'')$. Lemma 3.7.7(a)(iii,iv) tell us that $\varphi(w'')$ is odd and $m_{w''} = 2$. Since $\varphi(w'')$ is odd, Lemma 3.7.8 tells us that $\Gamma_{v''} \cdot \Gamma_{w''} < 2$. On the other hand, since $w'' \in N(v'')$, we have that $\Gamma_{v''} \cdot \Gamma_{w''} \geq 1$. This implies that

$$\begin{aligned} \delta(v'') &= (1 - m_{v''}) \chi(\Gamma_{v''}) + \sum_{w'' \in N(v'')} (m_{w''} - 1) \Gamma_{v''} \cdot \Gamma_{w''} + \sum_{w'' \in C(v'')} \Gamma_{v''} \cdot \Gamma_{w''} \\ &= (1 - 2)2 + (2 - 1)1 + (2 - 1)1 + 1 \\ &= 1. \end{aligned}$$

Therefore

$$\sum_{v'' \in S_1(v)} \delta(v'') = \sum_{v'' \in S_1(v)} 1 = s_v \quad (\text{since Lemma 3.7.5(c)(iii) implies that } \#S_1 = s_v). \quad \square$$

Lemma 3.7.19. *Suppose $v \in V(T_B)$ is odd. Then*

$$\sum_{v'' \in S_2(v)} \delta(v'') = l_v - r_v.$$

Proof. Let $S_2 = S_2(v)$ and $S_0(v) = \{\tilde{v}\}$. Suppose $v'' \in S_2$. Lemma 3.7.5(c)(iv,viii) tells us that $\Gamma_{v''} \cong \mathbb{P}_k^1$, $v'' \in C(\tilde{v})$, $m_{v''} = 1$ and $\psi(\Gamma_{v''}) = \Gamma_v \cap H$ where H is an irreducible horizontal

divisor occuring in (f) on $\text{Bl}_n(\mathbb{P}_R^1)$.

Since $\psi(\Gamma_{v''})$ is a point that belongs to a unique odd component of $(\text{Bl}_n(\mathbb{P}_R^1))_s$, Lemma 3.7.7(a)(i,ii) tell us that $\#N(v'') = 1$ and $\#C(v'') = 0$. Since $v'' \in C(\tilde{v})$, we have that $N(v'') = \{\tilde{v}\}$. Lemma 3.7.5(c)(ii) implies that $m_{\tilde{v}} = 2$. Since $\tilde{v} \in N(v'')$ and $\varphi(\tilde{v}) (= v)$ is odd, Lemma 3.7.8 applied to the pair v'', \tilde{v} tells us that $\Gamma_{v''} \cdot \Gamma_{w''} < 2$. On the other hand, since $\tilde{v} \in N(v'')$, we have that $\Gamma_{v''} \cdot \Gamma_{w''} \geq 1$. This implies that

$$\begin{aligned} \delta(v'') &= (1 - m_{v''}) \chi(\Gamma_{v''}) + \sum_{w'' \in N(v'')} (m_{w''} - 1) \Gamma_{v''} \cdot \Gamma_{w''} + \sum_{w'' \in C(v'')} \Gamma_{v''} \cdot \Gamma_{w''} \\ &= (1 - 1)2 + (2 - 1)1 + 0 \\ &= 1. \end{aligned}$$

Therefore

$$\sum_{v'' \in S_2(v)} \delta(v'') = \sum_{v'' \in S_2(v)} 1 = l'_v = l_v - r_v \quad (\text{since Lemma 3.7.5(c)(iv) implies that } \#S_2 = l'_v).$$

□

Lemma 3.7.20. *Suppose $v \in V(T_B)$ is odd (in particular, v is not the root). Then*

$$D(v) = \begin{cases} -2 - r_v + 3s_v + 2l_v & \text{if } v \text{ is odd and } p_v \text{ is even} \\ -1 - r_v + 3s_v + 2l_v & \text{if } v \text{ is odd and } p_v \text{ is odd.} \end{cases}$$

Proof. Combine Lemmas 3.7.17, 3.7.18, 3.7.19. □

3.7.21 Formula for $D(v)$

Theorem 3.7.22. *Let $v \in V(T_B)$. Then*

$$D(v) = \begin{cases} (l_v \bmod 2) + 2r_v + 2s_v & \text{if } v \text{ is even} \\ -2 - r_v + 3s_v + 2l_v & \text{if } v \text{ is odd and } p_v \text{ is even} \\ -1 - r_v + 3s_v + 2l_v & \text{if } v \text{ is odd and } p_v \text{ is odd.} \end{cases}$$

Proof. This follows directly from Lemma 3.7.14 and Lemma 3.7.20. □

3.8 Comparison of the two discriminants

One might hope that the inequality $D(v) \leq d(v)$ holds for every vertex $v \in V(T_B)$, but this is not true. It is however true after a slight alteration of the function D .

3.8.1 A new decomposition of the Deligne discriminant

Define a new function E on $V(T_B)$ as follows:

$$E(v) = \begin{cases} -(l_v \bmod 2) - \sum_{\substack{v' \in C(v) \\ v' \text{ odd}}} (2 - \text{wt}_{v'}(\text{wt}_{v'} - 1)) & \text{if } v \text{ is even} \\ r_v + s_v + 2 - \text{wt}_v(\text{wt}_v - 1) - \sum_{\substack{v' \in C(v) \\ v' \text{ odd}}} (2 - \text{wt}_{v'}(\text{wt}_{v'} - 1)) & \text{if } v \text{ is odd, } p_v \text{ even} \\ r_v + s_v + 1 - \text{wt}_v(\text{wt}_v - 1) - \sum_{\substack{v' \in C(v) \\ v' \text{ odd}}} (2 - \text{wt}_{v'}(\text{wt}_{v'} - 1)) & \text{if } v \text{ and } p_v \text{ are odd.} \end{cases}$$

For $v \in V(T_B)$, set $D'(v) := D(v) + E(v)$.

Using Lemma 3.7.2, we get

$$\sum_{\substack{v' \in C(v) \\ v' \text{ odd}}} 2 = \begin{cases} 2s_v & \text{if } v \text{ is odd} \\ 2r_v & \text{if } v \text{ is even} \end{cases}$$

We can use this, along with Theorem 3.7.22 to simplify the expression of D' .

$$D'(v) = \begin{cases} 2s_v + \sum_{\substack{v' \in C(v) \\ v' \text{ odd}}} \text{wt}_{v'}(\text{wt}_{v'} - 1) & \text{if } v \text{ is even} \\ 2(l_v + s_v) - \text{wt}_v(\text{wt}_v - 1) + \sum_{\substack{v' \in C(v) \\ v' \text{ odd}}} \text{wt}_{v'}(\text{wt}_{v'} - 1) & \text{if } v \text{ is odd} \end{cases} \quad (3.1)$$

Lemma 3.8.2. *The following equalities hold.*

$$\sum_{\substack{v \in V(T_B) \\ v \text{ even}}} \sum_{\substack{v' \in C(v) \\ v' \text{ odd}}} -(2 - \text{wt}_{v'}(\text{wt}_{v'} - 1)) + \sum_{\substack{v \in V(T_B) \\ v \text{ odd}}} \left(2 - \text{wt}_v(\text{wt}_v - 1) - \sum_{\substack{v' \in C(v) \\ v' \text{ odd}}} (2 - \text{wt}_{v'}(\text{wt}_{v'} - 1)) \right) = 0.$$

$$\sum_{\substack{v \in V(T_B) \\ v \text{ even}}} -(l_v \bmod 2) + \sum_{\substack{v \in V(T_B) \\ v \text{ odd}}} r_v = 0.$$

$$\sum_{\substack{v \in V(T_B) \\ v \text{ odd} \\ p_v \text{ is odd}}} -1 + \sum_{\substack{v \in V(T_B) \\ v \text{ odd}}} s_v = 0.$$

Proof. The first equality can be rewritten as

$$\sum_{v \in V(T_B)} \sum_{\substack{v' \in C(v) \\ v' \text{ odd}}} -(2 - \text{wt}_{v'}(\text{wt}_{v'} - 1)) + \sum_{\substack{v \in V(T_B) \\ v \text{ odd}}} (2 - \text{wt}_v(\text{wt}_v - 1)) = 0.$$

Since the root is an even vertex, every odd vertex has a parent. This implies that

$$\sum_{v \in V(T_B)} \sum_{\substack{v' \in C(v) \\ v' \text{ odd}}} -(2 - \text{wt}_{v'}(\text{wt}_{v'} - 1)) = - \sum_{\substack{v \in V(T_B) \\ v \text{ odd}}} (2 - \text{wt}_v(\text{wt}_v - 1)).$$

We have that

$$\begin{aligned} \sum_{\substack{v \in V(T_B) \\ v \text{ even}}} -(l_v \bmod 2) &= \sum_{\substack{v \in V(T_B) \\ v \text{ even} \\ v \text{ has an odd parent}}} -1 \quad (\text{by Lemma 3.7.3}) \\ &= \sum_{\substack{w \in V(T_B) \\ w \text{ odd}}} \sum_{\substack{v \in C(w) \\ w \text{ even}}} -1 \\ &= \sum_{\substack{w \in V(T_B) \\ w \text{ odd}}} -r_w \quad (\text{by Lemma 3.7.2}). \end{aligned}$$

We have that

$$\begin{aligned} \sum_{\substack{v \in V(T_B) \\ v \text{ odd} \\ p_v \text{ is odd}}} -1 &= \sum_{\substack{w \in V(T_B) \\ w \text{ odd}}} \sum_{\substack{v \in C(w) \\ w \text{ odd}}} -1 \\ &= \sum_{\substack{w \in V(T_B) \\ w \text{ odd}}} -s_w \quad (\text{by Lemma 3.7.2}). \end{aligned}$$

□

Lemma 3.8.3.

$$\sum_{v \in V(T_B)} E(v) = 0.$$

Proof. The sum of the left hand sides of the three equalities in Lemma 3.8.2 equals $\sum_{v \in V(T_B)} E(v)$, which is therefore 0. \square

For an odd $v \in V(T_B)$ such that $\text{wt}_v > 2$, let $L_v = \{w \in C(v) \mid \text{wt}_w = 2\}$. Define a new function D'' on $V(T_B)$ as follows:

$$D''(v) = \begin{cases} D'(v) - 2 & \text{if } v \text{ is an odd leaf and } \text{wt}_v = 2 \\ D'(v) & \text{if } v \text{ is odd, not a leaf, and } \text{wt}_v = 2 \\ D'(v) + 2\#L_v & \text{if } v \text{ is odd, and } \text{wt}_v > 2 \\ D'(v) & \text{if } v \text{ is even.} \end{cases}$$

Lemma 3.8.4.

$$\sum_{v \in V(T_B)} D''(v) = \sum_{v \in V(T_B)} D'(v).$$

Proof. For an odd leaf $v \in V(T_B)$ such that $\text{wt}_v = 2$, let q_v denote the least ancestor of v such that $\text{wt}_{q(v)} \geq 3$ (here least ancestor means the ancestor farthest away from the root); such an ancestor exists as the root has weight $2g + 2 \geq 3$. If $v \in V(T_B)$ is odd and $\text{wt}_v = 2$, then p_v must also be odd by Lemma 3.7.2. A repeated application of this fact tells us that if v is an odd leaf such that $\text{wt}_v = 2$, then q_v is odd.

For any vertex $v \in V(T_B)$, let T_v denote the complete subtree of T_B with root v (see section 8 for the definition of complete subtree). Suppose v is an odd vertex such that $\text{wt}_v > 2$. We will now prove the following three claims.

- If $w \in L_v$ and $u \in T_w$, then u is odd and $\text{wt}_u = 2$.
- If $w \in L_v$, then T_w is a chain (that is, every vertex in T_w has at most one child).
- If $v' \in V(T_B)$ is an odd leaf such that $\text{wt}_{v'} = 2$ and $q_{v'} = v$, then there exists a unique $w \in L_v$ such that $v' \in V(T_w)$.

Suppose $w \in L_v$ and $u \in T_w$. Since $u \in T_w$, the definition of the function wt tells us that $\text{wt}_u \leq \text{wt}_w = 2$. On the other hand, Lemma 3.6.2 tells us that $\text{wt}_u \geq 2$. Therefore, $\text{wt}_u = 2$. A repeated application of Lemma 3.7.2 along the path from v to u tells us that u is odd. This proves the first claim.

Suppose $w \in L_v$ and $u \in T_w$. Suppose $u_1, u_2 \in C(u)$ are distinct. The first claim shows $\text{wt}_{u_1} = \text{wt}_{u_2} = 2$. The definition of wt then tells us that $\text{wt}_w \geq \text{wt}_u \geq \text{wt}_{u_1} + \text{wt}_{u_2}$. Since $\text{wt}_w = 2$ and $\text{wt}_{u_1} + \text{wt}_{u_2} = 4$, this is a contradiction. Therefore every vertex in T_v has at most one child, and this proves the second claim.

Suppose $v' \in V(T_B)$ is an odd leaf such that $\text{wt}_{v'} = 2$ and $q_{v'} = v$. Let w be the greatest ancestor of v' such that $\text{wt}_w = 2$ (here greatest ancestor means the ancestor closest to the root). Then $\text{wt}_{p_w} > 2$. The definition of q then implies $p_w = q_{v'} = v$. This implies that $w \in L_v$. If $w_1, w_2 \in L_v$, then T_{w_1} and T_{w_2} have no vertices in common. This proves that every $v' \in M_v$ can belong to $V(T_w)$ for at most one $w \in L_v$. This finishes the proof of the third claim.

Let $M_v = \{v' \in V(T_B) \mid v' \text{ is an odd leaf, } \text{wt}_{v'} = 2, q_{v'} = v\}$. We will now use the claims above to show that there is a bijection $\kappa: L_v \rightarrow M_v$. Let $w \in L_v$. Let v' be the unique leaf in the chain T_w . Then v' is an odd leaf and $\text{wt}_{v'} = 2$. Furthermore, w is an ancestor of v' such that $\text{wt}_w = 2$ and $\text{wt}_v = \text{wt}_{p_w} > 2$, which shows $q_{v'} = v$. Set $\kappa(w) = v'$. The third claim shows that κ is a bijection. Therefore $\#M_v = \#L_v$.

This implies that

$$\sum_{\substack{v' \text{ is an odd leaf} \\ \text{wt}_{v'}=2}} 2 = \sum_{\substack{v \text{ odd} \\ \text{wt}_v > 2}} \sum_{v' \in M_v} 2 = \sum_{\substack{v \text{ odd} \\ \text{wt}_v > 2}} 2 \#M_v = \sum_{\substack{v \text{ odd} \\ \text{wt}_v > 2}} 2\#L_v.$$

This tells us that

$$\sum_{v \in V(T_B)} (D''(v) - D'(v)) = \sum_{\substack{v \in V(T_B) \\ v \text{ odd leaf} \\ \text{wt}_v=2}} -2 + \sum_{\substack{v \in V(T_B) \\ v \text{ odd} \\ \text{wt}_v > 2}} 2\#L_v = 0. \quad \square$$

Lemma 3.8.5.

(a) If $v \in V(T_B)$, then

$$\text{wt}_v \geq l'_v + 3r_v + 2s_v \geq l_v + 2s_v.$$

(b) If $r_v = s_v = 0$, then $\text{wt}_v = l'_v$.

Proof.

(a) Suppose $u \in C(v)$. Lemma 3.6.2 tells us that $\text{wt}_u \geq 2$. If u is of odd weight, then $\text{wt}_u \geq 3$. Therefore

$$\begin{aligned} \text{wt}_v &= l'_v + \sum_{u \in C(v)} \text{wt}_u \quad (\text{by the definitions of } l'_v \text{ and } \text{wt}) \\ &\geq l'_v + \sum_{\substack{u \in C(v) \\ \text{wt}_u \text{ is odd}}} 3 + \sum_{\substack{u \in C(v) \\ \text{wt}_u \text{ is even}}} 2 \\ &\geq l'_v + 3r_v + 2s_v \\ &= l_v + 2r_v + 2s_v \\ &\geq l_v + 2s_v. \end{aligned}$$

(b) If $r_v = s_v = 0$, then $C(v) = \emptyset$ and therefore $\text{wt}_v = l'_v + \sum_{u \in C(v)} \text{wt}_u = l'_v$. \square

We are now ready to compare the two discriminants. We first compare the local contributions.

Lemma 3.8.6. *If $v \in V(T_B)$, then $D''(v) \leq d(v)$. If v is even, then $D''(v) = d(v)$ if and only if every even child of v has weight 2. If v is odd, then $D''(v) = d(v)$ if and only if either $\text{wt}_v = 2$ or $\text{wt}_v = 3$ and v has no even children.*

Proof. If $v \in V(T_B)$ is even, then

$$\begin{aligned}
D''(v) - d(v) &= D'(v) - d(v) \\
&= 2s_v + \sum_{\substack{v' \in C(v) \\ v' \text{ odd}}} \text{wt}_{v'}(\text{wt}_{v'} - 1) - \sum_{v' \in C(v)} \text{wt}_{v'}(\text{wt}_{v'} - 1) \\
&\quad \text{(by Lemma 3.6.4 and Equation 3.1)} \\
&= \sum_{\substack{v' \in C(v) \\ v' \text{ even}}} (2 - \text{wt}_{v'}(\text{wt}_{v'} - 1)) \quad \text{(by Lemma 3.7.2)} \\
&\leq 0 \quad \text{(by Lemma 3.6.2)}.
\end{aligned}$$

From this, it follows that if v is even, then $D''(v) = d(v)$ if and only if the inequality above is actually an equality, that is, if and only if every even child of v has weight 2.

From now on assume $v \in V(T_B)$ is odd. Then

$$\begin{aligned}
D'(v) - d(v) &= 2(l_v + s_v) - \text{wt}_v(\text{wt}_v - 1) + \sum_{\substack{v' \in C(v) \\ v' \text{ odd}}} \text{wt}_{v'}(\text{wt}_{v'} - 1) - \sum_{v' \in C(v)} \text{wt}_{v'}(\text{wt}_{v'} - 1) \\
&\quad (3.2) \\
&= 2(l_v + s_v) - \text{wt}_v(\text{wt}_v - 1) - \sum_{\substack{v' \in C(v) \\ v' \text{ even}}} \text{wt}_{v'}(\text{wt}_{v'} - 1),
\end{aligned}$$

where the first equality follows from Lemma 3.6.4 and Equation 3.1. Lemma 3.6.2 tells us that $\text{wt}_v \geq 2$. We will handle vertices with $\text{wt}_v = 2$ and with $\text{wt}_v \geq 3$ separately.

Suppose $\text{wt}_v = 2$. Lemma 3.8.5(a) implies that $l'_v + 3r_v + 2s_v \leq \text{wt}_v = 2$. This implies that $r_v = 0$. Lemma 3.8.5(b) implies that either

(i) $l'_v = 2$ and $s_v = 0$, or,

(ii) $l'_v = 0$ and $s_v = 1$.

In both cases, since $r_v = 0$ and v is odd, Lemma 3.7.2 tells us that

$$\sum_{\substack{v' \in C(v) \\ v' \text{ even}}} \text{wt}_{v'}(\text{wt}_{v'} - 1) = 0.$$

In case (i), we have that v is an odd leaf of weight 2 and

$$\begin{aligned}
D''(v) - d(v) &= D'(v) - d(v) - 2 \\
&= 2(l_v + s_v) - \text{wt}_v(\text{wt}_v - 1) - \sum_{\substack{v' \in C(v) \\ v' \text{ even}}} \text{wt}_{v'}(\text{wt}_{v'} - 1) - 2 \\
&= 2(2 + 0) - 2(2 - 1) + 0 - 2 \\
&= 0.
\end{aligned}$$

In case (ii), we have that v is not a leaf and $\text{wt}_v = 2$ and

$$\begin{aligned}
D''(v) - d(v) &= D'(v) - d(v) \\
&= 2(l_v + s_v) - \text{wt}_v(\text{wt}_v - 1) - \sum_{\substack{v' \in C(v) \\ v' \text{ even}}} \text{wt}_{v'}(\text{wt}_{v'} - 1) \\
&= 2(0 + 1) - 2(2 - 1) - 0 \\
&= 0.
\end{aligned}$$

Now suppose $\text{wt}_v \geq 3$. By definition, $\#L_v \leq s_v$.

$$\begin{aligned}
2\#L_v + 2(l_v + s_v) - \text{wt}_v(\text{wt}_v - 1) &\leq 2(l_v + 2s_v) - \text{wt}_v(\text{wt}_v - 1) & (3.3) \\
&\leq 2\text{wt}_v - \text{wt}_v(\text{wt}_v - 1) & \text{(by Lemma 3.8.5(a))} \\
&= \text{wt}_v(3 - \text{wt}_v) \\
&\leq 0.
\end{aligned}$$

This implies that

$$\begin{aligned}
D''(v) - d(v) &= D'(v) - d(v) + 2\#L_v \\
&= 2(l_v + s_v) - \text{wt}_v(\text{wt}_v - 1) - \left(\sum_{\substack{v' \in C(v) \\ v' \text{ even}}} \text{wt}_{v'}(\text{wt}_{v'} - 1) \right) + 2\#L_v \\
&\hspace{15em} \text{(by Equation 3.2)} \\
&\leq - \sum_{\substack{v' \in C(v) \\ v' \text{ even}}} \text{wt}_{v'}(\text{wt}_{v'} - 1) \quad \text{(by Equation 3.3)} \\
&\leq 0 \quad \text{(by Lemma 3.6.2)}.
\end{aligned}$$

If v is odd and $D''(v) = d(v)$, then either $\text{wt}_v = 2$ or $\text{wt}_v = 3$ and $r_v = 0$ and $\#L_v = s_v$. By Lemma 3.7.2, $r_v = 0$ if and only if v has no even children. Since every child of v has weight atleast 2 and has weight bounded above by $\text{wt}_v = 3$, Lemma 3.7.2 tells us that $\#L_v = s_v$. \square

We are now ready to prove the main theorem.

Proof of Theorem 1.0.1. Construct the proper regular model X as above. Let $n(X)$ denote the number of irreducible components of the special fiber of X and let n be the number of components of the special fiber of the minimal proper regular model \mathcal{X} of C .

To prove $-\text{Art}(X/S) \leq \nu(\Delta)$, sum the inequality of Lemma 3.8.6 over all vertices of T_B and use Lemmas 3.8.3–3.8.4.

We have the equalities

$$\begin{aligned}
-\text{Art}(X/S) &= n(X) - 1 + \tilde{f} \\
-\text{Art}(\mathcal{X}/S) &= n - 1 + \tilde{f}
\end{aligned}$$

where \tilde{f} is the conductor of the ℓ -adic representation $\text{Gal}(\overline{K}/K) \rightarrow \text{Aut}_{\mathbb{Q}_\ell}(H_{\text{et}}^1(X_{\overline{\eta}}, \mathbb{Q}_\ell))$ [Liu94, Proposition 1]. The minimal proper regular model can be obtained by blowing down some subset (possibly empty) of irreducible components of the special fiber of X_s , so $n \leq n(X)$.

Putting everything together, we get

$$-\mathrm{Art}(\mathcal{X}/S) \leq -\mathrm{Art}(X/S) \leq \nu(\Delta).$$

□

Remark 3.8.7. Lemma 3.8.6 and the proof of Theorem 1.0.1 tell us that $-\mathrm{Art}(\mathcal{X}/S) = \nu(\Delta)$ if and only if the model X is already minimal and the tree T_B satisfies certain strict conditions. Call a subset S of vertices of T_B a connecting chain if

- for any $v \in V(T_B)$, if v lies in the path between two vertices of S , then $v \in S$, and,
- every vertex in S has exactly two neighbours in T_B .

If $-\mathrm{Art}(X/S) = \nu(\Delta)$, then the conditions on the tree T_B tell us that if we replace every connecting chain of 3 or more vertices with a chain of 2 vertices (or equivalently, disregard the length of the chains in T_B and just consider the underlying topological space of T_B), then the tree T_B has height at most 2 (that is, the path from any vertex to the root has at most one other vertex), and all children of the root have at most 3 neighbours. The model X is not minimal if and only if it has contractible -1 curves, and this happens if and only if the tree T_B has an odd vertex v such that $l'_v = 0$, v has an even parent, and v has exactly one child, and that child is even.

Corollary 3.8.8. *Let n be the number of components of the special fiber of the minimal proper regular model of C over R . Then*

$$n \leq \nu(\Delta) + 1.$$

Proof. Since the conductor \tilde{f} is a nonnegative integer, $n - 1 \leq n - 1 + \tilde{f} \leq \nu(\Delta)$. □

Remark 3.8.9. The equality $n = \nu(\Delta) + 1$ holds if and only if $\tilde{f} = 0$ in addition to all the conditions for $-\mathrm{Art}(\mathcal{X}/S) = \nu(\Delta)$ to hold. By the Néron-Ogg-Shafarevich criterion, $\tilde{f} = 0$ if and only if the Jacobian of C has good reduction.

Chapter 4

Computing orders of component groups and Tamagawa numbers of Jacobians

4.1 Explicit computation of the orders of component groups

4.1.1 The weighted dual graph

Let C be a nice K -curve and let X be a proper regular model of the curve C over R . The weighted dual graph G of X_s is defined as follows. The vertices of G are the irreducible components of X_s . For each vertex v of G , let Γ_v denote the corresponding irreducible component of X_s and let m_v denote the multiplicity of Γ_v in X_s . The number of edges between two distinct vertices v and w equals $\Gamma_v \cdot \Gamma_w$. There are no edges connecting a vertex to itself. For every edge e between the vertices v and w , the weight of e , denoted $\text{wt}(e)$, is defined to be $m_v m_w$.

Remark 4.1.2. This is the graph obtained by deleting all the loops (i.e., the edges that connect a vertex to itself) in the usual dual graph associated to X_s that is used in algebraic geometry. Including the loops will not alter the proof below, since a graph and the associated loopless graph have the same Laplacian operator.

Let Φ denote the component group scheme of the Néron model of the Jacobian of C .

Remark 4.1.3. Let β be the map defined in Theorem 2.8.11. The component group asso-

ciated to the pair (G, β) (as defined in Section 2.6) coincides with $\Phi(\bar{k})$. In fact, the map α in Section 2.6 coincides with the map α in Theorem 2.8.11.

In this section, we give a formula for $\Phi(\bar{k})$ in terms of the graph G . Special cases of this formula already appear in [Lor93]; see, for instance, Proposition 4.19 therein. A version of this formula is also implicit in the proof of [Lor89, Corollary 3.5].

4.1.4 The formula

Theorem 4.1.5. *Let $m = \gcd(m_v \mid v \in V(G))$. Let Φ denote the component group scheme of the Néron model of the Jacobian of C . Then*

$$\#\Phi(\bar{k}) = m^2 \left(\sum_{T \in \mathcal{S}(G)} \prod_{v \in V(T)} m_v^{\#N_T(v)-2} \right). \quad (4.1)$$

Proof. Let $r = \#V(G)$. As in the statement of Corollary 2.8.12, let M be the $r \times r$ matrix corresponding to the intersection pairing. Let a_v denote the absolute value of the $(r-1) \times (r-1)$ minor that we get from M by deleting the row and column corresponding to the vertex v . Corollary 2.8.12 shows that if $v \in V(G)$, then the order of the component group is equal to $(\frac{m}{m_v})^2 a_v$. Let $(N_{vv'})$ be the $r \times r$ matrix defined by $N_{vv'} = m_v m_{v'} M_{vv'}$ for every $v, v' \in V(G)$. Fix a vertex \tilde{v} of G . Let b denote the absolute value of the $(r-1) \times (r-1)$ minor that we get from N by deleting the row and column corresponding to the vertex \tilde{v} .

Then

$$\begin{aligned}
\#\Phi(\bar{k}) &= \left(\frac{m}{m_{\bar{v}}}\right)^2 a_{\bar{v}} \\
&= \frac{m^2}{\left(\prod_{v \in V(G)} m_v\right)^2} b \\
&= \frac{m^2}{\left(\prod_{v \in V(G)} m_v\right)^2} \sum_{T \in \mathcal{S}(G)} \prod_{e \in E(T)} \text{wt}(e) \quad (\text{by Theorem 2.6.2}) \\
&= \frac{m^2}{\left(\prod_{v \in V(G)} m_v\right)^2} \sum_{T \in \mathcal{S}(G)} \prod_{v \in V(T)} m_v^{\#N_T(v)} \\
&= m^2 \left(\sum_{T \in \mathcal{S}(G)} \prod_{v \in V(T)} m_v^{\#N_T(v)-2} \right),
\end{aligned}$$

since $V(T) = V(G)$ for any spanning tree T of G . □

Remark 4.1.6. The formula also holds under the assumption that R is merely strictly henselian, provided we also assume that all the e_i are equal to 1 and that X admits a section.

Remark 4.1.7. If the dual graph G is a tree, the formula simplifies to

$$\#\Phi(\bar{k}) = m^2 \prod_{v \in V(G)} m_v^{\#N_G(v)-2}.$$

Remark 4.1.8. Specializing to the case where C is an elliptic curve, we recover the correct orders of the component groups for each of the Kodaira types.

4.1.9 Applications of the formula

Criterion for uniform bounds on the orders of component groups

In the case of elliptic curves, the order of the component group is bounded above by 4 if we exclude curves of reduction type I_n . In the theorem below, we provide a generalization of this fact for higher genus curves. We begin by proving a lemma in graph theory.

Lemma 4.1.10. *A vertex v of a graph G belongs to some cycle of G if and only if there exists a spanning tree T of G and an edge $e \in E(G)$ such that $v \in D(e)$ and $e \notin E(T)$.*

Sketch of proof. The ‘if’ direction follows from the fact that adding any edge of $E(G) - E(T)$ to a spanning tree produces a graph that contains a cycle. The ‘only if’ direction follows from the fact that any spanning tree of $(V(G), E(G) - \{e\}, w)$ is a spanning tree of G , where e is an edge in a cycle having v as an endpoint. \square

Theorem 4.1.11. *Assume that X/S is the minimal proper regular model of the curve C/K and that the genus g of C satisfies $g \geq 2$. Let G be the dual graph of X_s . Assume further that if $v \in V(G)$ corresponds to a (-2) -curve (that is, a \mathbb{P}_k^1 of self-intersection -2), then v does not belong to any cycle of G . Then there exists an integer $n(g)$, depending only on the genus g of C , such that the order of the component group of the special fiber of the Néron model of the Jacobian of C is bounded above by $n(g)$.*

Proof. Lemma 4.1.10 and the assumption on (-2) -curves in the theorem imply that the edges in any chain of (-2) -curves belong to every spanning tree. In other words, every chain of (-2) -curves is a connecting chain. Contracting all chains of (-2) -curves produces a graph G' . [Win74, Corollary 4.3] implies that G' is the dual graph of the special fiber of a regular S -curve X' . Since a vertex v that is part of a connecting chain has exactly two neighbours in every spanning tree, the exponent $N_T(v) - 2$ equals 0 for every spanning tree T for every such vertex. It follows that such a vertex does not contribute to the order of the component group by formula (4.1). This implies that the order of the component group of G' equals the order of the component group of G . Since we also assumed that X is minimal and $g \geq 2$, Theorem 2.8.7 implies that there are only finitely many possibilities for the weighted dual graph of X'_s , if we fix the genus g of X'_η . For a fixed g , we can compute the order of the component group of the special fiber of the Néron model of the Jacobian for each of these finitely many weighted dual graphs and take the maximum of these numbers to be $n(g)$. \square

Remark 4.1.12. The condition in the theorem above is strictly weaker than requiring the toric rank of C be 0. The toric rank 0 condition would imply that the graph G has no cycles.

Remark 4.1.13. A naïve bound for $n(g)$ that one gets by examining the Artin–Winters argument is $n(g) \sim O((2g - 2)^{8(2g-2)^2})$. It might be possible to improve this bound by analyzing the combinatorics of these graphs more carefully.

Structure of the component group: periodicity

We will now prove an analogue of [BN07, Corollary 4.7]. The key step in the proof of Theorem 4.1.11 is the fact that contracting connecting chains in the dual graph does not alter the order of the component group. The structure of the group, however, does depend on the length of the chain. For example, the Kodaira types I_n^* all have component groups of order 4, but the component group is either $\mathbb{Z}/2\mathbb{Z} \times \mathbb{Z}/2\mathbb{Z}$ or $\mathbb{Z}/4\mathbb{Z}$ depending on whether n is even or odd. In this example, the structure of the component group only depends on the length of the connecting chain modulo 2. This suggests that if we have a family of dual graphs which only differ in the length of a single connecting chain, and if all the vertices in the connecting chain have multiplicity m , then the structure of the component group should be m -periodic, i.e., it should depend only on the length of the chain modulo m . More precisely:

Theorem 4.1.14. *Let (G, β) be a graph equipped with a multiplicity function. Let L be a length m connecting chain in G such that $\beta(v) = m$ for all $v \in V(L)$. Define α as in Section 2.6. Assume that $\alpha_{v,v} = -2$ for every $v \in V(L)$. Let (G', β') be the pair obtained by contracting the chain L . Then the component group of (G', β') is isomorphic to the component group of (G, β) .*

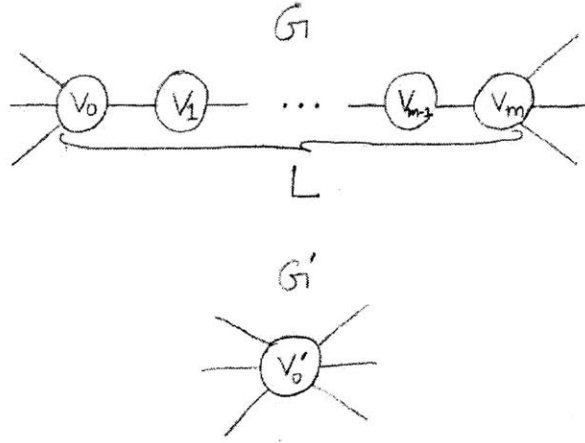

Proof. Let $\Phi(G) = \ker \beta / \text{im } \alpha$ and let $\Phi(G') = \ker \beta' / \text{im } \alpha'$ as in Section 2.6. Choose an ordering (v_0, v_1, \dots, v_m) of $V(L)$ as in the definition of a chain, and let $\{v'_0\}$ be the image of $V(L)$ in $V(G')$. Let $f_0: V(G') \rightarrow V(G)$ be the section of the natural quotient map $V(G) \rightarrow V(G')$ that satisfies $f_0(v'_0) = v_0$. Let $f: \mathbb{Z}^{V(G')} \rightarrow \mathbb{Z}^{V(G)}$ be the linear map defined by f_0 on the corresponding basis elements. We will now define another map h such that the maps in the following diagram commute.

$$\begin{array}{ccccc}
 \mathbb{Z}^{V(G')} & \xrightarrow{\alpha'} & \mathbb{Z}^{V(G')} & \xrightarrow{\beta'} & \mathbb{Z} \\
 \downarrow h & & \downarrow f & & \parallel \\
 \mathbb{Z}^{V(G)} & \xrightarrow{\alpha} & \mathbb{Z}^{V(G)} & \xrightarrow{\beta} & \mathbb{Z}
 \end{array}$$

Then f will induce a homomorphism from the homology $\Phi(G')$ of the top row to the homology $\Phi(G)$ of the bottom row.

We will describe h by giving its value on each $v' \in V(G')$. In order to define h , for every $v' \in V(G')$, it suffices to find $v \in \mathbb{Z}^{V(G)}$ (depending on v') such that $\alpha(v) = f(\alpha'(v'))$; we can then define $h(v') = v$.

Case 1: $v' \notin \{v'_0\} \cup f_0^{-1}(N_G(v_m))$.

In this case, let $h(v') := f_0(v')$. Since the edges emanating from v' are in bijection with the edges emanating from $f_0(v')$, it follows that $\alpha(f_0(v')) = f(\alpha'(v'))$.

Case 2: $v' \in f_0^{-1}(N_G(v_m)) - \{v'_0\}$.

In this case $f(\alpha'(v')) = \alpha(f_0(v')) + \Gamma_{v'} \cdot \Gamma_{v'_0}(v_m - v_0)$. It therefore suffices to find $t_1 \in \mathbb{Z}^{V(G)}$ such that $\alpha(t_1) = \Gamma_{v'} \cdot \Gamma_{v'_0}(v_m - v_0)$, since we can then define $h(v') = f_0(v') + t_1$.

Let $V(G) - V(L) = D_0 \cup D_m$, where D_0 (respectively D_m) consists of the vertices of G having a path to L meeting L only at v_0 (respectively v_m). Let $t = mv_m + \sum_{w \in D_m} \beta(w)w$. If $v \notin D_m \cup \{v_{m-1}, v_m\}$, then the vertex v has no neighbours in $D_m \cup \{v_m\}$, so the coefficient of v in $\alpha(t)$ is 0. For any vertex v , we have $\alpha(v) = \alpha_{v,v}v + \sum_{w \in N_G(v)} \alpha_{v,w}w$; it follows that if $v \in D_m$, then the coefficient of v in $\alpha(t)$ equals the coefficient of v in $\alpha(\sum_{w \in V(G)} \beta(w)w)$. The latter is 0 since $\sum_{w \in V(G)} \beta(w)\alpha_{w',w} = 0$ for every $w' \in V(G)$. By a similar argument, the coefficient of v_m in $\alpha(t + \beta(v_{m-1})v_{m-1})$ is 0 since it equals the coefficient of v_m in $\alpha(\sum_{w \in V(G)} \beta(w)w)$. The same type of argument also shows that the coefficient of v_{m-1} in $\alpha(t - mv_m)$ is 0. Since $\beta(v_{m-1}) = \beta(v_m) = m$, we conclude that $\alpha(t) = mv_{m-1} - mv_m$.

Fix j such that $0 \leq j \leq m-1$. Let $x_j = \sum_{i=1}^j iv_i$. Since $\alpha(v_j) = v_{j-1} - 2v_j + v_{j+1}$, an inductive argument shows that $\alpha(x_j) = v_0 - (j+1)v_j + jv_{j+1}$. Let $t_1 = -\Gamma_{v'} \cdot \Gamma_{v'_0}(x_{m-1} + t)$. It follows that $\alpha(t_1) = \Gamma_{v'} \cdot \Gamma_{v'_0}(v_m - v_0)$.

Case 3: $v' = v'_0$.

We have $f(\alpha'(v'_0)) = \alpha(v_0 + v_m) - v_1 - v_{m-1} + 2v_m$. It therefore suffices to find $t_2 \in \mathbb{Z}^{V(G)}$ such that $\alpha(t_2) = 2v_m - v_1 - v_{m-1}$. We may then define $h(v'_0) = v_0 + v_m + t_2$.

Let t be defined as in Case 2. For $1 \leq j \leq m-1$, let $y_j = \sum_{i=1}^j (i-1)v_i$. Once again an inductive argument as in Case 2 shows that $\alpha(y_j) = v_1 - jv_j + (j-1)v_{j+1}$. Let $t_2 = -y_{m-1} - t$. Then $\alpha(t_2) = 2v_m - v_1 - v_{m-1}$.

We have now proved that f induces a well-defined map from $\Phi(G')$ to $\Phi(G)$. We want to prove that this map is an isomorphism. Since $|\Phi(G')| = |\Phi(G)|$ (by the proof of Theorem 4.1.11), it suffices to prove that it is a surjection. Let $u \in \ker \beta$. We will inductively construct a sequence of elements u_0, u_1, \dots, u_m such that

- $u_0 = u$ and $u_m \in \text{im } f$,
- For every i satisfying $0 \leq i \leq m-1$, we have $u_{i+1} - u_i \in \text{im } \alpha \subset \ker \beta$.

- For every i satisfying $1 \leq i \leq m$, and for every $j \in \{m - i + 1, m - i + 2, \dots, m\}$, the coefficient of v_j in u_i is 0.

For the inductive step, suppose that $1 \leq i \leq m - 2$ and $u_i = \sum -a_v v$, where $a_v \in \mathbb{Z}$. Let

$$u_{i+1} = u_i + \alpha(a_{v_{m-i}} v_{m-i-1}) = u_i + a_{v_{m-i}}(v_{m-i-2} - 2v_{m-i-1} + v_{m-i}).$$

From the equation above, it follows that for $j \in \{m - i + 1, m - i + 2, \dots, m\}$ the coefficient of v_j in u_{i+1} is the same as that in u_i , and that the coefficient of v_{m-i} in u_{i+1} is $-a_{v_{m-i}} + a_{v_{m-i}} = 0$. The induction hypothesis implies that $a_{v_j} = 0$ for $j \in \{m - i + 1, m - i + 2, \dots, m\}$. This finishes the induction. So to finish the construction, it now suffices to prove that $u_m \in \text{im } f$.

Let $T = V(G) - \{v_1, v_2, \dots, v_m\}$. By the definition of the map f , it maps $\mathbb{Z}^{V(G)}$ isomorphically on to the subset of elements of $\mathbb{Z}^{V(G)}$ supported on T . This isomorphism maps $\ker \beta'$ isomorphically to the set of elements of $\ker \beta$ supported on T . Since $u_m \in \ker \beta$ and is supported on T , this shows that $u_m \in \text{im } f$. Since $u_m - u_0 \in \text{im } \alpha$, this completes the proof of surjectivity of f on to $\Phi(G)$. \square

Remark 4.1.15. Fix g . If $\text{char } k = 0$, then it is possible to list all the groups that can arise as the component group of the Jacobian of a nice curve of genus g by combining the theorem above with Theorem 2.8.7 and Theorem 2.8.8.

The Néron component series for Jacobians

In this section, we provide an alternate proof of [HN12, Chapter 3, Proposition 3.1.1], that works in both the equal characteristic and mixed characteristic cases. For the proof, we use the explicit formula in Theorem 4.1.5 and the behaviour of snc models under tame extensions, as described in Section 2.10.

Proposition 4.1.16. [HN12, Chapter 3, Proposition 3.1.1] *Let X be the minimal snc model of a nice K -curve of genus $g \geq 1$. Let $d \in \mathbb{N}'$ be an integer prime to $e(X)$. Let \mathcal{A} denote the Néron model of the Jacobian of X_η and let $\mathcal{A}(d)$ denote the Néron model of the Jacobian of*

$X \times_K K(d)$. Let t denote the toric rank of \mathcal{A} . Then

$$|\Phi(\mathcal{A}(d))| = d^t |\Phi(\mathcal{A})|.$$

Proof. Let $X(d)$ be the minimal desingularization of the normalization X_d of $X \times_R R(d)$. Let G be the dual graph of X_s and let G' be the dual graph of $X(d)_s$. As mentioned before Proposition 2.10.1, $X(d)$ is a snc model. Let J be the Jacobian of X_η .

Case 1: J is an elliptic curve with multiplicative reduction.

In this case, [LLR04, Theorem 6.6] tells us that the minimal snc model and the minimal regular model coincide, and X_s is also a cycle of rational curves, where the rational curves in the cycle all have the same multiplicity, say m . Since the number of spanning trees of G equals the number of vertices in the cycle, and for each spanning tree T , the product $\prod_{v \in V(T)} m_v^{N_T(v)-2}$ equals $1/m^2$, the explicit formula in Theorem 4.1.5 implies that the order of the component group of the Néron model of J equals the number of vertices in the cycle G .

We will first show that $X(d)_s$ is also a cycle of rational curves, and then compute the number of rational curves in the cycle. Formula 4.1 would once again imply that the order of the component group equals the number of vertices in the cycle G' .

Proposition 2.10.1(ii) implies that every component of $(X_d)_s$ intersects exactly two other components. Since $(X_d)_s$ is connected by Zariski's connectedness principle, we conclude that it is a cycle of rational curves. Proposition 2.10.1(iii) tells us that in order to obtain $X(d)_s$ from $(X_d)_s$, we have to replace each node in the cycle of rational curves by a chain of rational curves of appropriate length. This implies that $(X_d)_s$ is also a cycle of rational curves. Now,

- Proposition 2.10.1(ii) implies that the number of irreducible components of $(X_d)_s$ equals $\gcd(d, m)$ times the number of irreducible components of X_s .
- Proposition 2.10.1(iii) and Proposition 2.10.2 imply that the preimage of each singular point of $(X_d)_s$ is a chain of rational curves, where the number of rational curves in the chain equals $d/\gcd(d, m)$.
- The number of singular points of $(X_d)_s$ equals the number of irreducible components

of $(X_d)_s$.

Combining the arguments above, we conclude that the number of irreducible components of $X(d)_s$ is d times the number of irreducible components of X_s , and this finishes the proof in this case, since the toric rank t equals 1.

Case 2: J is not an elliptic curve with multiplicative reduction.

Then either $g \geq 2$, or J is an elliptic curve with good or additive reduction. Lemma 2.10.5 implies that X_s and $(X_d)_s$ have the same dual graph. Proposition 2.10.1(iii) implies that G' is a subdivision of G . Let $\pi: E(G') \rightarrow E(G)$ be the surjective map that maps an edge of G' to the unique edge in G that it is a subdivision of. Let v and w be neighbouring vertices of G . In this case, the proof of [HN12, Lemma 2.3.2] tells us that $\gcd(d, m_v, m_w) = 1$. Let

- $h_v = \gcd(d, m_v)$,
- $h_w = \gcd(d, m_w)$,
- $m_v = h_v m'_v$,
- $m_w = h_w m'_w$, and,
- $d = h_v h_w d'$.

Then $dm'_v m'_w = d' m_v m_w$. Let v' and w' be the corresponding vertices of G' and let $u_1, u_2, \dots, u_\lambda$ be the intermediate vertices. Then Lemma 2.10.5(ii) tells us that $m_{v'} = m'_v$ and $m_{w'} = m'_w$. Let r be the unique solution to $rm_{v'} + m_{w'} = 0 \pmod{d'}$. Let $(\mu_1, \mu_2, \dots, \mu_\lambda)$ be the multiplicity vector associated to the tuple $(d', r, m_{v'}, m_{w'})$. By Proposition 2.10.2 $m_{u_i} = \mu_i$. By Lemma 2.9.1,

$$\frac{d}{m_v m_w} = \frac{d'}{m'_v m'_w} = \frac{1}{m'_v \mu_1} + \frac{1}{\mu_1 \mu_2} + \dots + \frac{1}{\mu_{\lambda-1} \mu_\lambda} + \frac{1}{\mu_\lambda m'_w}. \quad (4.2)$$

Let H be a connected graph. Let $S(H)$ be the collection of spanning trees of H . The first Betti number $t(H)$ of a connected graph H equals $|V(H)| - |E(H)| + 1$. Let $T \in S(H)$. Since $|V(H)| = |V(T)|$, and the first Betti number of a tree equals 0, it follows that $\#(E(H) - E(T)) = t(H)$. For a spanning tree T of a dual graph H , let $\varphi(T) = \prod_{v \in V(H)} m_v^{N_T(v) - 2}$. Fix

a dual graph H . Let $\delta: E(H) \rightarrow \mathbb{N}$ be the map defined by $\delta(e) := m_v m_w$, where v and w are the endpoints of e , and m_v and m_w are the multiplicities of the corresponding irreducible components in the special fiber.

Fix $T' \in S(G')$. Let T be the subgraph of G such that $V(T) = V(G)$ and such that $E(T) = \{e \in E(G) \mid \pi^{-1}(e) \subset E(T')\}$. Since G' is a subdivision of G , it follows that T is a spanning tree of G . The construction $T' \mapsto T$ defines a map $\tau: S(G') \rightarrow S(G)$. Let $T' \in S(B')$ and let $\tau(T') = T$. Let $B' = E(G') - E(T')$ and let $B = E(G) - E(T)$. Let π_T be the restriction of π to $\pi^{-1}(B)$. Let $\epsilon: \pi^{-1}(B) \rightarrow \mathbb{Q}^\times$ be the map defined by $\epsilon(e) = \delta(\pi(e))/\delta(e)$. Since G' is a subdivision of G , it follows that

- $t(G') = t(G)$, and,
- there is a multiplicity-preserving bijection between the vertices of T' of degree ≥ 3 and those of T of degree ≥ 3 .

The two facts above imply that

$$\varphi(T')/\varphi(T) = \prod_{e \in B'} \epsilon(e).$$

Since G' is a subdivision of G , it follows that there exists a bijection

$$\{T'' \in S(G') \mid \tau(T'') = T\} \longleftrightarrow \text{Sections } \sigma: B \rightarrow \pi^{-1}(B) \text{ of } \pi_T.$$

Let \mathfrak{s} denote the set of sections of π_T . Since $t(G) = t(G')$, and the toric rank t equals the first Betti number of the graphs G and G' (by [BLR90, 9.2.5, 9.2.8]), it follows that

$\#B = \#B' = t$. Now

$$\begin{aligned}
\sum_{T' \in \tau^{-1}(T)} \frac{\varphi(T')}{\varphi(T)} &= \sum_{\sigma \in \mathfrak{S}} \prod_{e \in B} \epsilon(\sigma(e)) \\
&= \prod_{e \in B} \sum_{e' \in \pi^{-1}(e)} \epsilon(e') \\
&= \prod_{e \in B} \delta(e) \sum_{e' \in \pi^{-1}(e)} \frac{1}{\delta(e')} \\
&= \prod_{e \in B} \delta(e) \frac{d}{\delta(e)} \quad (\text{by Equation (4.2)}) \\
&= d^{\#B} = d^t.
\end{aligned}$$

Now

$$\sum_{T' \in \mathcal{S}(G')} \varphi(T') = \sum_{T \in \mathcal{S}(G)} \sum_{T' \in \tau^{-1}(T)} \varphi(T') = d^t \sum_{T \in \mathcal{S}(G)} \varphi(T).$$

To finish the proof, it suffices to prove that $\gcd(m_v \mid v \in V(G)) = \gcd(m_{v'} \mid v' \in V(G'))$ by the formula in Theorem 4.1.5. Lemma 2.9.2 implies that the gcd of the multiplicities of the components of X_d and the gcd of the multiplicities of the components of $X(d)$ are equal. This implies that it now suffices to prove $\gcd(m_v \mid v \in V(G)) = \gcd(m_v / \gcd(m_v, d) \mid v \in V(G))$. The right hand side divides the left hand side. To prove the other divisibility, we use the fact that G is connected, and the fact that if v and w are any pair of neighbouring vertices in G , then $\gcd(m_v, m_w, d) = 1$ (this follows from the proof of Lemma 2.10.5 in [HN12]). This concludes the proof. \square

4.2 Explicit computation of Tamagawa numbers

In this section, we will show that we can use a version of the matrix-tree theorem for directed weighted multigraphs to compute Tamagawa numbers. The notation used in this section is consistent with the notation in Section 2.8.13.

4.2.1 The quotient graph \tilde{G}

Let $X^{\text{st}} = X \times_R R^{\text{st}}$. Let G denote the dual graph of X_s^{st} , and let $V = V(G)$. We now define a directed weighted multigraph \tilde{G} , which we call the quotient graph. The set of vertices of \tilde{G} , which we denote \tilde{V} , is the set of irreducible components of X_s . The set \tilde{V} can also naturally be identified with the set of orbits of V under the natural action of $\text{Gal}(\bar{k}/k)$. This identification gives rise to a quotient map $\pi: V \rightarrow \tilde{V}$ where we map a vertex v to the corresponding orbit. For any two vertices \tilde{w} and \tilde{v} in \tilde{V} , the number of directed edges with tail \tilde{w} and head \tilde{v} , which we denote $\alpha_{\tilde{w}\tilde{v}}$, is defined as follows. Fix any $w \in \pi^{-1}(\tilde{w})$. Then $\alpha_{\tilde{w}\tilde{v}} = \sum_{v \in \pi^{-1}(\tilde{v})} \Gamma_v \cdot \Gamma_w$. Since the Galois action transitively permutes the vertices $w \in \pi^{-1}(\tilde{w})$ and preserves intersection numbers, the sum is independent of the choice of $w \in \pi^{-1}(\tilde{w})$. This defines the vertices and directed edges of \tilde{G} .

We now define a weight function on \tilde{G} . For every $\tilde{v} \in \tilde{V}$, let $|\tilde{v}|$ denote the size of the orbit corresponding to \tilde{v} . For any $\tilde{v} \in \tilde{V}$, let $\Gamma_{\tilde{v}}$ denote the corresponding irreducible component of X_s , and let $m_{\tilde{v}}$ denote the multiplicity of $\Gamma_{\tilde{v}}$ in the special fiber X_s . For any directed edge e with tail \tilde{w} and head \tilde{v} , the weight of the edge e , denoted $\text{wt}(e)$ is defined to be $m_{\tilde{v}} m_{\tilde{w}} |\tilde{w}|$.

4.2.2 Explicit computation of Tamagawa numbers

In this section, we will show how to combine Theorem 2.8.14 and Theorem 2.6.1 to explicitly compute Tamagawa numbers. In the rest of this section, we will assume that $\text{Gal}(\bar{k}/k)$ is procyclic in order to be able to apply Theorem 2.8.14.

Remark 4.2.3. The order of the component group can also be computed using using Theorem 2.6.1 (this corresponds to the special case where $k = \bar{k}$). The formula that we obtain for the component group using Theorem 2.6.1 can be checked to be equal to the formula obtained in Theorem 4.1.5. We included the proof in Section 4.1 since the graph that appears in Section 4.1 is more closely related to the dual graph that appears in algebraic geometry.

Let α and β be as in Section 2.8.13. We now show that if we make the appropriate modifications to α and β , we can use Theorem 2.6.1 to compute Tamagawa numbers. Define

maps $\delta_1, \delta_2, \alpha_1, \beta_1, \beta_2$ as follows:

$$\begin{aligned}
\delta_1: \mathbb{Z}^{\tilde{V}} &\rightarrow \mathbb{Z}^{\tilde{V}} \\
(b_{\tilde{v}}) &\mapsto (b_{\tilde{v}}m_{\tilde{v}}|\tilde{v}|) \\
\delta_2: \mathbb{Z}^{\tilde{V}} &\rightarrow \mathbb{Z}^{\tilde{V}} \\
(b_{\tilde{v}}) &\mapsto (b_{\tilde{v}}m_{\tilde{v}}) \\
\alpha_1 &= \delta_1 \circ \alpha \circ \delta_2 \\
\beta_1: \mathbb{Z}^{\tilde{V}} &\rightarrow \mathbb{Z} \\
(b_{\tilde{v}}) &\mapsto \sum_{\tilde{v} \in \tilde{V}} b_{\tilde{v}} \\
\beta_2: \mathbb{Z} &\rightarrow \mathbb{Z}^{\tilde{V}} \\
b &\mapsto (b, b, \dots, b).
\end{aligned}$$

We have $\beta_1\delta_1 = \beta$, so $\beta_1\alpha_1 = \beta_1\delta_1\alpha\delta_2 = \beta\alpha\delta_2 = 0$. This implies that $\text{im}(\alpha_1) \subset \ker \beta_1$.

We now prove a lemma in linear algebra that allows us to compare the orders of the finite groups $\ker(\beta_1)/\text{im}(\alpha_1)$ and $\ker(\beta)/\text{im}(\alpha)$.

Lemma 4.2.4. *Let n be a nonnegative integer. Let $D, D': \mathbb{Z}^n \rightarrow \mathbb{Z}^n$ be two rank n linear operators whose matrices are diagonal. Let $A: \mathbb{Z}^n \rightarrow \mathbb{Z}^n$ be a rank $n-1$ linear operator. Let $S: \mathbb{Z}^n \rightarrow \mathbb{Z}$ denote the linear operator which takes a vector to the sum of its coordinates, and let $\Delta: \mathbb{Z} \rightarrow \mathbb{Z}^n$ denote the diagonal embedding. Assume $SDA = 0$ and $AD'\Delta = 0$. Let d, d' be positive integers such that $d\mathbb{Z} = \text{im}(SD)$ and $d'\mathbb{Z} = \text{im}(SD')$ respectively. Then*

$$\# \frac{\ker(SD)}{\text{im } A} = \frac{d}{|\det D|} \cdot \# \frac{\ker S}{\text{im}(DA)} = \frac{dd'}{|\det D||\det D'|} \cdot \# \frac{\ker S}{\text{im}(DAD')}. \quad (4.3)$$

Proof. The integer d is the gcd of the diagonal entries of D . Thus $\frac{1}{d}D \in M_n(\mathbb{Z})$. Similarly $\frac{1}{d'}D' \in M_n(\mathbb{Z})$. Replacing D by $\frac{1}{d}D$ and replacing D' by $\frac{1}{d'}D'$ multiplies the five ratios in Equation (4.3) by $1, d^{n-1}, d^{1-n}, (dd')^{n-1}$ and $(dd')^{1-n}$ respectively. Therefore we may assume $d = d' = 1$ without any loss of generality.

We now prove the first equality. For this, we show that the following sequence is exact.

$$0 \rightarrow \frac{\ker(SD)}{\operatorname{im} A} \xrightarrow{D} \frac{\ker S}{\operatorname{im}(DA)} \rightarrow \frac{\mathbb{Z}^n}{\operatorname{im} D} \rightarrow 0.$$

The exactness at the left follows because D is an injection, and therefore restricts to an injection from $\ker(SD)$ to $\ker S$, and also implies that $D^{-1}(\operatorname{im}(DA)) = \operatorname{im} A$. The exactness at the middle follows because $D(\ker(SD)) = \ker S \cap \operatorname{im} D$. For the exactness on the right, it suffices to show that $\mathbb{Z}^n/(\ker S + \operatorname{im} D) = 0$. This follows because $\mathbb{Z}^n/(\ker S + \operatorname{im} D) \simeq \operatorname{im} S/\operatorname{im}(SD) = \mathbb{Z}/d\mathbb{Z} = 0$, since $d = 1$. Since all the groups in the above exact sequence are finite and $\# \left(\frac{\mathbb{Z}^n}{\operatorname{im} D} \right) = |\det D|$, we get

$$\# \frac{\ker(SD)}{\operatorname{im} A} |\det D| = \# \frac{\ker S}{\operatorname{im}(DA)}.$$

This finishes the proof of the first equality.

Let $A' = DA$. For the second equality, we show that the following sequence is exact.

$$0 \rightarrow \frac{\mathbb{Z}^n}{\operatorname{im} D'} \xrightarrow{A'} \frac{\ker S}{\operatorname{im}(A'D')} \rightarrow \frac{\ker S}{\operatorname{im} A'} \rightarrow 0.$$

First, since $SA' = SDA = 0$, the map on the left is well-defined. Since $d' = 1$, it follows that $\operatorname{im} D'\Delta$ is a rank 1 lattice generated by a primitive vector, and therefore is a saturated submodule of \mathbb{Z}^n . On the other hand, we have $\operatorname{im} D'\Delta \subset \ker A'$ (since $A'D'\Delta = DAD'\Delta = 0$), and $\ker A'$ is also a rank 1 lattice (since D' is injective and A has rank $n - 1$). Therefore we must have $\operatorname{im} D'\Delta = \ker A'$, which implies that $\ker A' \subset \operatorname{im} D'$. This in turn implies that $A'^{-1}(\operatorname{im} A'D') = \operatorname{im} D' + \ker A' = \operatorname{im} D'$. This proves exactness on the left of the sequence above. The exactness at the other two positions is immediate. \square

Lemma 4.2.5. *Let m and \tilde{m} be as defined as in Theorem 2.8.14.*

$$\# \left(\frac{\ker \beta}{\operatorname{im} \alpha} \right) = \frac{m\tilde{m}}{\prod_{\tilde{v} \in \tilde{V}} m_{\tilde{v}}^2 |\tilde{v}|} \# \left(\frac{\ker \beta_1}{\operatorname{im} \alpha_1} \right).$$

Proof. This follows directly from Lemma 4.2.4 with $A = \alpha$, $D = \delta_1$ and $D' = \delta_2$. \square

We will now show how we can use Theorem 2.6.1 to compute $\#(\ker \beta_1 / \text{im } \alpha_1)$. Recall the definition of the graph \tilde{G} as defined in the beginning of this section.

Lemma 4.2.6. *Fix a vertex \tilde{w} of the directed weighted multigraph \tilde{G} . Let $\tilde{S}_{\tilde{w}}(\tilde{G})$ be the set of directed spanning trees into the vertex \tilde{w} . Then*

$$\# \left(\frac{\ker \beta_1}{\text{im } \alpha_1} \right) = \sum_{T \in \tilde{S}_{\tilde{w}}(\tilde{G})} \prod_{e \in E(T)} \text{wt}(e).$$

Proof. We observe that $\# \left(\frac{\ker \beta_1}{\text{im } \alpha_1} \right)$ is equal to the absolute value of the determinant of the reduced Laplacian operator on \tilde{G} , with the fixed vertex \tilde{w} as the sink (since X_s is connected, every vertex of \tilde{G} is a sink). The determinant can then be computed using Theorem 2.6.1. \square

Theorem 4.2.7. *Let q, m and \tilde{m} be defined as in Theorem 2.8.14.*

$$\#\Phi(k) = \frac{\tilde{m}^2}{q \prod_{\tilde{v} \in \tilde{V}} m_{\tilde{v}}^2 |\tilde{v}|} \left(\sum_{T \in \tilde{S}_{\tilde{w}}(\tilde{G})} \prod_{e \in E(T)} \text{wt}(e) \right).$$

Proof. Combine Theorem 2.8.14, Lemma 4.2.5 and Lemma 4.2.6. \square

Bibliography

- [AW71] M. Artin and G. Winters, *Degenerate fibres and stable reduction of curves*, *Topology* **10** (1971), 373–383. MR0476756 ↑2.8.2, 2.8.7
- [BL99] Siegfried Bosch and Qing Liu, *Rational points of the group of components of a Néron model*, *Manuscripta Math.* **98** (1999), no. 3, 275–293. MR1717533 ↑2.8.13, 2.8.14
- [Blo87] Spencer Bloch, *de Rham cohomology and conductors of curves*, *Duke Math. J.* **54** (1987), no. 2, 295–308. MR899399 ↑1
- [BLR90] Siegfried Bosch, Werner Lütkebohmert, and Michel Raynaud, *Néron models*, *Ergebnisse der Mathematik und ihrer Grenzgebiete (3) [Results in Mathematics and Related Areas (3)]*, vol. 21, Springer-Verlag, Berlin, 1990. MR1045822 ↑1, 2.7, 2.8.9, 2.8.11, 2.8.12, 3.1, 4.1.9
- [BN07] Matthew Baker and Serguei Norine, *Riemann-Roch and Abel-Jacobi theory on a finite graph*, *Adv. Math.* **215** (2007), no. 2, 766–788. MR2355607 ↑1, 4.1.9
- [CES03] Brian Conrad, Bas Edixhoven, and William Stein, $J_1(p)$ has connected fibers, *Doc. Math.* **8** (2003), 331–408 (electronic). MR2029169 ↑2.9, 2.9
- [CS97] P. Yu. Chebotarev and E. V. Shamis, *A matrix forest theorem and the measurement of relations in small social groups*, *Avtomat. i Telemekh.* **9** (1997), 125–137. MR1609615 ↑2.6.2
- [Del85] Pierre Deligne, *Le discriminant d'une courbe*, *Appendice 3 Lettre Quillen* (June 20, 1985). ↑2.4.1, 1
- [GKZ08] I. M. Gelfand, M. M. Kapranov, and A. V. Zelevinsky, *Discriminants, resultants and multidimensional determinants*, *Modern Birkhäuser Classics*, Birkhäuser Boston, Inc., Boston, MA, 2008. Reprint of the 1994 edition. MR2394437 ↑
- [HN12] Lars Halvard Halle and Johannes Nicaise, *Néron models and base change* (September 25, 2012). <http://arxiv.org/abs/1209.5556>. ↑2.10, 2.10.1, 2.10.2, 2.10.3, 2.10.4, 2.10.5, 2.11, 2.11.1, 4.1.9, 4.1.16, 4.1.9, 4.1.9
- [Kau99] Ivan Kausz, *A discriminant and an upper bound for ω^2 for hyperelliptic arithmetic surfaces*, *Compositio Math.* **115** (1999), no. 1, 37–69. MR1671741 ↑1, 3.1
- [KS04] Kazuya Kato and Takeshi Saito, *On the conductor formula of Bloch*, *Publ. Math. Inst. Hautes Études Sci.* **100** (2004), 5–151. MR2102698 ↑2.3
- [Lic68] Stephen Lichtenbaum, *Curves over discrete valuation rings*, *Amer. J. Math.* **90** (1968), 380–405. MR0230724 ↑2.2
- [Liu02] Qing Liu, *Algebraic geometry and arithmetic curves*, *Oxford Graduate Texts in Mathematics*, vol. 6, Oxford University Press, Oxford, 2002. Translated from the French by Reinie Ern e, Oxford Science Publications. MR1917232 ↑2.10
- [Liu94] ———, *Conducteur et discriminant minimal de courbes de genre 2*, *Compositio Math.* **94** (1994), no. 1, 51–79. MR1302311 ↑1, 1, 2.3.3, 3.8.1

- [Liu96] ———, *Modèles entiers des courbes hyperelliptiques sur un corps de valuation discrète*, Trans. Amer. Math. Soc. **348** (1996), no. 11, 4577–4610. MR1363944 ↑2.1.3
- [LL99] Qing Liu and Dino Lorenzini, *Models of curves and finite covers*, Compositio Math. **118** (1999), no. 1, 61–102. MR1705977 ↑3.1.2, 3.1, 3.1, 3.1, b
- [LLR04] Qing Liu, Dino Lorenzini, and Michel Raynaud, *Néron models, lie algebras, and reduction of curves of genus one*, Invent. Math. **157** (2004), no. 3, 455–518. MR2092767 ↑4.1.9
- [Lor89] Dino J. Lorenzini, *Arithmetical graphs*, Math. Ann. **285** (1989), no. 3, 481–501. MR1019714 ↑1, 4.1.1
- [Lor90] ———, *Groups of components of Néron models of Jacobians*, Compositio Math. **73** (1990), no. 2, 145–160. MR1046735 ↑1, 3.2
- [Lor92] ———, *Jacobians with potentially good l -reduction*, J. Reine Angew. Math. **430** (1992), 151–177. MR1172912 ↑1
- [Lor93] ———, *On the group of components of a Néron model*, J. Reine Angew. Math. **445** (1993), 109–160. MR1244970 ↑4.1.1
- [Mau03] Sylvain Maugeais, *Relèvement des revêtements p -cycliques des courbes rationnelles semi-stables*, Math. Ann. **327** (2003), no. 2, 365–393. MR2015076 ↑1
- [Maz77] B. Mazur, *Modular curves and the Eisenstein ideal*, Inst. Hautes Études Sci. Publ. Math. **47** (1977), 33–186 (1978). MR488287 ↑1
- [Mum77] David Mumford, *Stability of projective varieties*, Enseignement Math. (2) **23** (1977), no. 1-2, 39–110. MR0450272 ↑1, 2.4
- [Oda95] Takayuki Oda, *A note on ramification of the Galois representation on the fundamental group of an algebraic curve. II*, J. Number Theory **53** (1995), no. 2, 342–355. MR1348768 ↑1
- [Ogg67] A. P. Ogg, *Elliptic curves and wild ramification*, Amer. J. Math. **89** (1967), 1–21. MR0207694 ↑1
- [PPW13] David Perkinson, Jacob Perlman, and John Wilmes, *Primer for the algebraic geometry of sandpiles*, Tropical and non-Archimedean geometry, 2013, pp. 211–256. MR3204273 ↑2.6.1
- [PS14] Bjorn Poonen and Michael Stoll, *Most odd degree hyperelliptic curves have only one rational point*, Ann. of Math. (2) **180** (2014), no. 3, 1137–1166. MR3245014 ↑1
- [Rum15] Robert Rumely, *The minimal resultant locus*, Acta Arith. **169** (2015), no. 3, 251–290. MR3361223 ↑
- [Sai87] Takeshi Saito, *Vanishing cycles and geometry of curves over a discrete valuation ring*, Amer. J. Math. **109** (1987), no. 6, 1043–1085. MR919003 ↑3.2, 3.2.2
- [Sai88] ———, *Conductor, discriminant, and the Noether formula of arithmetic surfaces*, Duke Math. J. **57** (1988), no. 1, 151–173. MR952229 ↑1, 2.5.1
- [Ser] Jean-Pierre Serre, *Linear representations of finite groups*, Springer-Verlag, New York-Heidelberg. Translated from the second French edition by Leonard L. Scott; Graduate Texts in Mathematics, Vol. 42. MR0450380 ↑2.3.1
- [Sil09] Joseph H. Silverman, *The arithmetic of elliptic curves*, Second, Graduate Texts in Mathematics, vol. 106, Springer, Dordrecht, 2009. MR2514094 ↑1
- [ST68] Jean-Pierre Serre and John Tate, *Good reduction of abelian varieties*, Ann. of Math. (2) **88** (1968), 492–517. MR0236190 ↑1
- [Uen88] Kenji Ueno, *Discriminants of curves of genus 2 and arithmetic surfaces*, Algebraic geometry and commutative algebra, Vol. II, 1988, pp. 749–770. MR977781 ↑1
- [Win74] Gayn B. Winters, *On the existence of certain families of curves*, Amer. J. Math. **96** (1974), 215–228. MR0357406 ↑2.8.8, 4.1.9