

An Investigation of Glass Cartridge Siliconization Processes for Improved Device Performance

By

Scott D. McArthur

B.S. Chemical and Biological Engineering
Tufts University, 2012

Submitted to the MIT Sloan School of Management and the Department of Mechanical Engineering in Partial Fulfillment of the Requirements for the Degrees of

Master of Business Administration and
Master of Science in Mechanical Engineering

In conjunction with the Leaders for Global Operations Program at the
Massachusetts Institute of Technology

June 2017

© 2017 Scott D. McArthur. All rights reserved.

The author hereby grants to MIT permission to reproduce and to distribute publicly paper and electronic copies of this thesis document in whole or in part in any medium now known or hereafter created.

Signature of Author

Signature redacted

MIT Sloan School of Management, Department of Mechanical Engineering
May 12, 2017

Certified by

Signature redacted

Thomas Roemer, Thesis Supervisor, Professor of Management

Certified by

Signature redacted

Jung-Hoon Chun, Thesis Supervisor, Professor of Mechanical Engineering

Accepted by

Signature redacted

Maura Herson, Director of MIT Sloan MBA Program, MIT Sloan School of Management

Accepted by

Signature redacted

Rohan Abeyaratne, Chair, Mechanical Engineering Graduate Committee

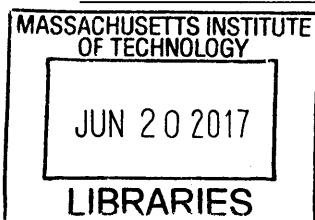

ARCHIVES



77 Massachusetts Avenue
Cambridge, MA 02139
<http://libraries.mit.edu/ask>

DISCLAIMER NOTICE

Due to the condition of the original material, there are unavoidable flaws in this reproduction. We have made every effort possible to provide you with the best copy available.

Thank you.

The images contained in this document are of the best quality available.

This page intentionally left blank.

An Investigation of Glass Cartridge Siliconization Processes for Improved Device Performance

by
Scott D. McArthur

Submitted to the MIT Sloan School of Management and the MIT Department of Mechanical Engineering on May 12, 2017 in Partial Fulfillment of the Requirements for the Degrees of Master of Business Administration and Master of Science in Mechanical Engineering

Abstract

This study aims to advance understanding of baked-in siliconization of cartridges for application in Insulin injection pens. This research is motivated by lack of knowledge of baked-in siliconization and business opportunities a better understanding can provide. The primary contribution from this work is the development of a recommended silicone profile that can significantly reduce friction force variation within a cartridge during device use.

An Insulin pen delivers Insulin to patients by the mechanical pushing of a rubber stopper through a cylindrical glass cartridge forcing the Insulin through a hypodermic needle at the cap end. This cartridge is coated with a very thin layer of silicone to reduce the force necessary for injection. This silicone layer is introduced to the cartridge prior to filling in the manufacturing process. This step of the filling process was characterized and results revealed different silicone profiles and friction force profiles for different filling lines. Correlations between silicone profile and friction forces were then developed for cartridges. As predicated, lower levels of silicone thickness and a higher percent of dry spots led to increased friction forces and higher variation among samples. These correlations were used to recommend a silicone profile with an average layer thickness greater than 60nm with fewer than 20% dry spots. Finally, atmospheric pressure plasma (APP) treatment was explored as a pre-treatment step to improve siliconization. Findings from APP feasibility studies showed that APP increases glass surface energy and wettability, but that its effect wears off over time and therefore impact on siliconization is still unknown.

These results set the stage for further research and process optimization of siliconization in the context of medical injection devices. Insights gained will contribute to design of new devices, improved manufacturing operations and increased quality for Sanofi and the pharmaceutical medical device industry. The opinions expressed herein are solely those of the author and do not necessarily reflect those of Sanofi.

Thesis Supervisor: Thomas Roemer
Title: Professor of Management Science, MIT Sloan School of Management

Thesis Supervisor: Jung-Hoon Chun
Title: Professor of Mechanical Engineering, MIT

This page intentionally left blank.

Acknowledgements

I would like to acknowledge the support of my MIT academic advisors, Professor Jung-Hoon Chun and Professor Thomas Roemer as well as my Sanofi advisors, Dr. Christoph Dette, Dr. Holger Kramm and Martin Otten. I would further like to thank my many colleagues at Sanofi for their support including Stefanie Becker, Silke Dittombee, Katerina Lenk and Fabian Voll. This work would not have been possible without several external collaborations including Dr. Sang-Ro Lee and his team at SEP, Inc., Steffen Ebert at Bosch GmbH and Andre Kempe at ScienceAnalytics. Finally I would like to thank the Leaders for Global Operations staff and my fellow LGO classmates for their guidance and support throughout the process.

Table of Contents

Abstract	1
Acknowledgements	3
List of Figures.....	8
List of Tables	9
1 Introduction.....	10
1.1 Baked-in Siliconization at Sanofi.....	10
1.1.1 Project Context.....	10
1.1.2 Project Motivation.....	11
1.2 Project Overview	11
1.3 Thesis Organization	12
2 Background.....	13
2.1 Global Diabetes Prevalence.....	13
2.2 Background of Sanofi	14
2.2.1 Overview of Sanofi Medical Devices	14
2.2.2 Overview of Sanofi Insulin Production	18
3 Literature Review.....	19
3.1 Baked-in Siliconization of Glass Cartridges.....	19
3.1.1 Silicone and Siliconization	19
3.1.2 Baked-in Siliconization	20
3.1.3 Prior LGO Thesis Work on Siliconization at Sanofi.....	21
3.2 Nanotribology: Friction and Lubrication	23
3.2.1 Friction	23
3.2.2 Lubrication	24
3.3 Optimization.....	27

3.4	Atmospheric Pressure Plasma	28
4	Data Collection Techniques.....	31
4.1	Core Analytical Techniques	31
4.2	Surface Layer Spectroscopy	31
4.3	Friction Forces Testing	32
4.4	Data Computation and Comparison	34
4.4.1	Rap.ID® Layer Explorer	34
4.4.2	Zwick® zwickiLine Test Equipment.....	35
5	Current State Filling Line Analysis	37
5.1	Data Collection and Sampling Procedure.....	37
5.2	Results	40
5.2.1	Summary of Results	40
5.2.2	Silicone Profile.....	41
5.2.3	Friction Forces.....	44
5.3	Characterization in the Context of Device Performance.....	47
5.3.1	Introduction to Pen Systems.....	47
5.3.2	Importance of Filling Line Flexibility.....	49
6	Friction Correlations and Recommended Silicone Profile.....	51
6.1	Silicone Amount and Friction Forces.....	51
6.2	Defining a Good Siliconization Profile	55
6.2.1	How to Define a Good Siliconization Profile.....	55
6.2.2	Silicone Layer Thickness Recommendation	56
6.2.3	Percent Dry Spot Recommendation	57
6.2.4	Silicon Profile Recommendations and Impact.....	59
7	Atmospheric Pressure Plasma Treatment.....	64
7.1	Opportunity for APP Treatment in Siliconization Process	64

7.2	APP Testing and Evaluation Methodology	64
7.3	APP Treatment at SEP	65
7.4	Glass Surface Effects.....	67
7.4.1	Contact Angle Measurements.....	67
7.4.2	Visual Wettability Measurements	68
7.4.3	Surface Roughness Measurements.....	68
7.5	Pre-Siliconization Washing Effects.....	72
7.5.1	Experiment Set-up	72
7.5.2	Experimental Results.....	72
7.6	Effect of APP Treatment over Time and Conclusions	75
7.6.1	Initial Conclusions	75
7.6.2	Effect of APP Treatment over Time.....	76
7.6.3	APP Treatment Conclusions	78
8	Conclusions and Recommendations.....	79
8.1	Impact and Key Findings	79
8.2	Filling Line Characterization.....	79
8.3	A Good Siliconization Profile	80
8.3.1	Defining a Good Siliconization Profile	80
8.3.2	Future Opportunities for Silicone Profile and Friction Correlations.....	82
8.4	Atmospheric Pressure Plasma Treatment.....	84
8.4.1	APP Key Findings	84
8.4.2	APP Future Opportunities.....	84
8.5	Process Optimization.....	85
9	References.....	87
	Appendix.....	90
	Appendix A: Rap.ID Data Translated	90

Appendix B: Rap.ID Images92
Appendix C: Friction Force Testing Methods.....93
Appendix D: Dimensional Considerations.....95
Appendix E: Siliconization Method Steps99
Appendix F: APP Study rap.ID Images.....100
Appendix G: Theoretical Evaluation of Friction and Lubrication Properties101

List of Figures

Figure 1-1: Insulin Cartridge	10
Figure 2-1: SoloStar® Injection Pen	14
Figure 2-2: Components of SoloStar® Pen.....	15
Figure 2-3: Glass Cartridge Components	16
Figure 2-4: Components of the 3D Pen	17
Figure 3-1: Effect of Silicone Amount on Friction Coefficient.....	22
Figure 3-2: Simplified force diagram during injection adapted from [19]	23
Figure 3-3: Stribeck Diagram [21]	25
Figure 3-4: APP Operating Principle [27].....	29
Figure 3-5: Wetting Effect [27].....	30
Figure 4-1: Example Layer Explorer Measurement Outputs	32
Figure 4-2: Simplified Force Profile for Cartridge during Injection	33
Figure 4-3: Correlating Silicone Profile to Friction Forces	36
Figure 5-1: Process Diagram of Filling Process at SFI [17]	38
Figure 5-2: Diving Needle Process	39
Figure 5-3: Micro-dosing Siliconization (left) and Pressure-time Siliconization (right).....	39
Figure 5-4: Sample Cartridge Box	40
Figure 5-5: Characteristic Silicone Profile for Filling Lines A, B, C.....	41
Figure 5-6: Example Differences in Silicone Profile Between Data Sets	42
Figure 5-7: Silicone Layer Height in Cartridges	43
Figure 5-8: Dry Spots in Cartridges.....	43
Figure 5-9: Friction Force Profile for Cartridges.....	45
Figure 5-10: Line Characterization - Average Friction Forces.....	46
Figure 5-11: Line Characterization - Variation of Gliding Forces	46
Figure 6-1: Friction Force Correlation with Silicone Amount, Averages.....	52
Figure 6-2: Average Gliding Force Correlation with Silicone Amount	53
Figure 6-3: Maximum Gliding Force Correlation with Silicone Amount.....	54
Figure 6-4: Typical Silicone Profile for Cartridge Siliconized at Bosch	55
Figure 6-5: Silicone Layer Thickness Correlation to Friction Forces	56
Figure 6-6: Silicone Layer Thickness Recommendation.....	57

Figure 6-7: Dry Spot Correlation to Friction Forces.....	58
Figure 6-8: Dry Spot Recommendation (expanded data set).....	59
Figure 6-9: Layer Thickness and Dry Spot Recommendation.....	60
Figure 6-10: Layer Thickness and Dry Spot Correlations Expanded Data Set.....	60
Figure 6-11: Data Fit Recommendation.....	61
Figure 6-12: Data by Filling Line.....	61
Figure 7-1: APP Generation for Cartridges [27].....	66
Figure 7-2: Contact Angle Measurement APP Study.....	67
Figure 7-3: Visual Wettability Test APP Study.....	68
Figure 7-4: Glass Surface Roughness Color Scaling 2D.....	69
Figure 7-5: Glass Surface Roughness 3D.....	70
Figure 7-6: Surface Roughness of Glass Samples.....	71
Figure 7-7: Variation Comparison for Cleaning Methods.....	73
Figure 7-8: Gliding Force Profiles Washing Study Set 1.....	74
Figure 7-9: Gliding Force Profiles Washing Study Set 2.....	74
Figure 7-10: Sample rap.ID Results for Washing Study.....	75
Figure 7-11: APP Treatment over Time.....	77
Figure 8-1: Cartridge Samples Achieving a ‘Good Silicone Profile’.....	81
Figure 8-2: Correlating Silicone and Friction Force Profiles Individually Example 1.....	82
Figure 8-3: Correlating Silicone and Friction Force Profiles Individually Example 2.....	83
Figure 8-4: Example DOE Set-up and Output.....	86

List of Tables

Table 3-1: Stribeck Regimes [22].....	26
Table 4-1: Silicone Profile Characteristics.....	34
Table 4-2: Characteristics of Fiction Force.....	35
Table 6-1: Silicone Profile Recommendation Impact on Variability.....	62
Table 7-1: APP Experimental Conditions.....	66
Table 7-2: Washing Effect Sample Groups.....	72
Table 7-3: Absolute Friction Force Measurements.....	73

1 Introduction

1.1 Baked-in Siliconization at Sanofi

1.1.1 Project Context

Baked-in siliconization is a process used to apply a thin layer of silicone to the surface of a desired material or substrate. At Sanofi Deutschland GmbH glass cartridges that serve as the primary container for Sanofi's Insulin products are coated on the inner surface by baked-in siliconization. The main purpose of this thin layer of silicone is to provide lubrication along the glass surface during Insulin injection. These glass cartridges, after being siliconized, baked, filled and capped are integrated in a mechanical delivery device and used to treat patients with diabetes. The cartridge pictured in Figure 1-1 measures 62mm in length and serves as the main focus for investigation in this work.

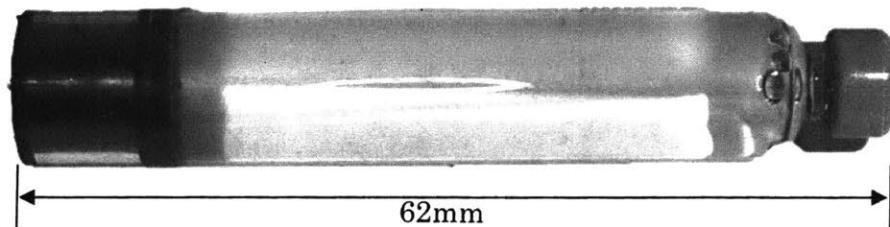

Figure 1-1: Insulin Cartridge

There is a strong business case to be made for the investment in improvement of this product. These cartridges are produced in high volume with over one million cartridges and integrated devices being manufactured every day. The market for diabetes therapy products is immense, projected to reach US\$116.1B by 2024 [1]. This market can be segmented into types of treatment and devices. The segment of interest is Insulin injection pens, which had a global market of US\$4.9B in 2015. With projections of CAGR of 7.9% from 2016 to 2026 the market is expected to reach US\$9.7B by the end of 2024 [2]. Capturing an additional 1% of this market could increase Sanofi's market value by US\$490M today or nearly US\$1B in 2024. Compared to their current market capitalization of US\$104B this is significant [3].

Improving the function of the cartridge pictured in Figure 1-1 has the potential to improve injection pen performance consistency, improving the patient experience. Sanofi's brand reputation is dependent on the performance of the complete device. Performance is defined primarily by functional injection, dose accuracy and minimal pain during injection. Ensuring high performance time and time again positions Sanofi to capture the additional market share described above.

1.1.2 Project Motivation

The motivation for this project is threefold. First, as a science driven organization Sanofi is always looking to expand its fundamental knowledge on the drugs and products it produces. Second, as a manufacturer Sanofi is committed to continuous improvement of its products and manufacturing processes. Thirdly, Sanofi is currently in late stage development of a new pen device, called the 3D. The 3D pen differs from existing pens Sanofi produces in that it relies on a spring for assisted injection (prior and current pens have all been designed for manual injection). This new feature requires better understanding and control of the forces counteracting the spring force, specifically pressure drop through a needle and friction forces between the rubber stopper and glass cartridge during injection. This project focuses on better understanding the latter.

1.2 Project Overview

Baked-in siliconization is important for cartridge performance, specifically in providing sufficient lubrication to maintain acceptable friction forces during injection. Beyond understanding that the silicone plays an important role in lubrication and reduces friction forces, there is a lack of understanding about how, specifically, the baked-in siliconization profile affects friction. It is important to understand this relationship and how the profile can be influenced on the filling lines to achieve a desired profile and ultimately consistent and reliable performance when integrated into the devices.

Intuition suggests that characteristics of the silicone profile on the inner surface of a cartridge impact the friction forces produced between the silicon coated glass surface and the rubber stopper during injection.

The first goal is to characterize the current state of the process to understand what types of silicone profiles are being generated by different siliconization methods on the filling lines. Because there are three different methods for applying silicone in Sanofi's filling process, one hypothesis is these different methods produce differences in the silicone profile of a cartridge. It may be the case, however, that there are other issues common to all methods such as cartridge cleaning or silicone emulsion that is preventing a good siliconization profile from being achieved.

The second goal is to develop a methodology for and the initial steps in defining a 'good siliconization profile.' Here the hypothesis tested states there is an optimum amount of silicone which provides low, acceptable friction forces beyond which increasing that layer thickness leads to marginal returns. The other critical hypothesis states dry spots, defined as extremely low levels or complete absence of silicone, within a cartridge cause increased friction and lead to device performance issues.

The third goal is to explore pre-treatment, specifically atmospheric pressure plasma (APP) treatment of the glass cartridge, prior to siliconization. Designing and executing a feasibility study will test the hypothesis that treating cartridges with APP will increase the surface energy and wettability of the glass, enabling a more evenly distributed siliconization profile and more desirable friction forces.

1.3 Thesis Organization

Following the brief introduction of this project topic and project goals this thesis will cover a literature review of the applicable topics in the order of their appearance later in the thesis. In this literature review the theoretical topics discussed include baked-in siliconization, nanotribology, siliconization process optimization and atmospheric pressure plasma. Next this thesis will cover the two main methods used for data collection and analysis, surface layer spectroscopy and friction force measurement. Armed with an understanding of how data is generated the thesis will then cover the three core areas of investigation for this project: First, filling line characterization; second, friction correlations and recommended silicone profile; and third, atmospheric pressure plasma treatment. Results, discussion and key findings will be covered for each core area of investigation. Finally key findings, conclusions and future work will be summarized in the final chapter of this document.

2 Background

2.1 Global Diabetes Prevalence

Diabetes is one of the major chronic diseases affecting a significant portion of the global population. As reported in 2014, the number of people with diabetes is over 420 million. Globally among adults over the age of 18, 8.5% are living with diabetes. Patients with diabetes cannot effectively regulate blood sugar due to lack of Insulin production by the pancreas or inability to effectively use Insulin in the process of blood sugar control. Diabetes significantly increases a patient's risk of heart attack, strokes, can lead to damaged organs, blood vessel and nerves and is the leading cause of kidney failure [4].

There are several factors that contribute to a patient's risk of diabetes including genetics, life style and diet. Preventing the onset of diabetes by maintaining a healthy life style with regular exercise and a diet low in sugar and saturated fat is critical to reducing the impact of this disease. However for patients already living with diabetes, managing the disease through treatment is essential to maintaining a high quality of life. Disease management for patients with diabetes often involves the administration of Insulin to supplement the body's lack of natural production. Introducing Insulin to a patient by a medical device allows for blood glucose and blood pressure control, significantly reducing the symptoms of patients. Biotechnology companies produce Insulin as a medical product to be used as medical therapy for patients with diabetes. With successful disease management including life style changes and use of Insulin products, diabetic patients can lead normal and high functioning lives [4].

2.2 Background of Sanofi

Sanofi is a global life sciences company headquartered in Paris. Sanofi has core healthcare solutions in human vaccines, diabetes, cardiovascular diseases, oncology, rare diseases, multiple sclerosis, consumer healthcare as well as animal health [5]. Sanofi operates in over 100 countries with industrial sites in more than 40 countries and its healthcare solutions are available in over 170 countries. In 2015, Sanofi was the 5th largest pharmaceutical company with net sales of €37 B. Of these sales, 20.5% were from diabetes related products and 36.2% of sales were to the United States [6].

Sanofi has several subsidiary companies including Sanofi-Avantis Deutschland GmbH. The core business of Sanofi-Avantis Deutschland GmbH is pharmaceutical and medical device manufacturing, specifically insulin products.

2.2.1 Overview of Sanofi Medical Devices

Medical device injectors deliver drug or biologic formulations to a patient. They are designed to provide an accurate dose injection of the desired product from a reservoir, cartridge or syringe through a hypodermic needle. The delivery method of these injectors can be manual or automatic and both disposable (single-use) and reusable devices are designed and produced [7].

Within Sanofi-Avantis Deutschland GmbH, the Medical Device Group (MED) and Site Frankfurt Devices (SFD) design and manufacture devices for insulin injection. The most common medical device used by patients with diabetes are insulin pens and Sanofi currently offers several varieties of these pens: SoloSTAR®, ClikSTAR®, AllSTAR® and JuniorSTAR®. These are all insulin injection pens that deliver a specified dose of insulin to the patient [8]. An example of the SoloSTAR® pen can be seen in Figure 2-1.



Figure 2-1: SoloStar® Injection Pen

Figure 2-2 shows the components of the Solostar pen. For this investigation the most relevant component of the pen system is the cartridge.

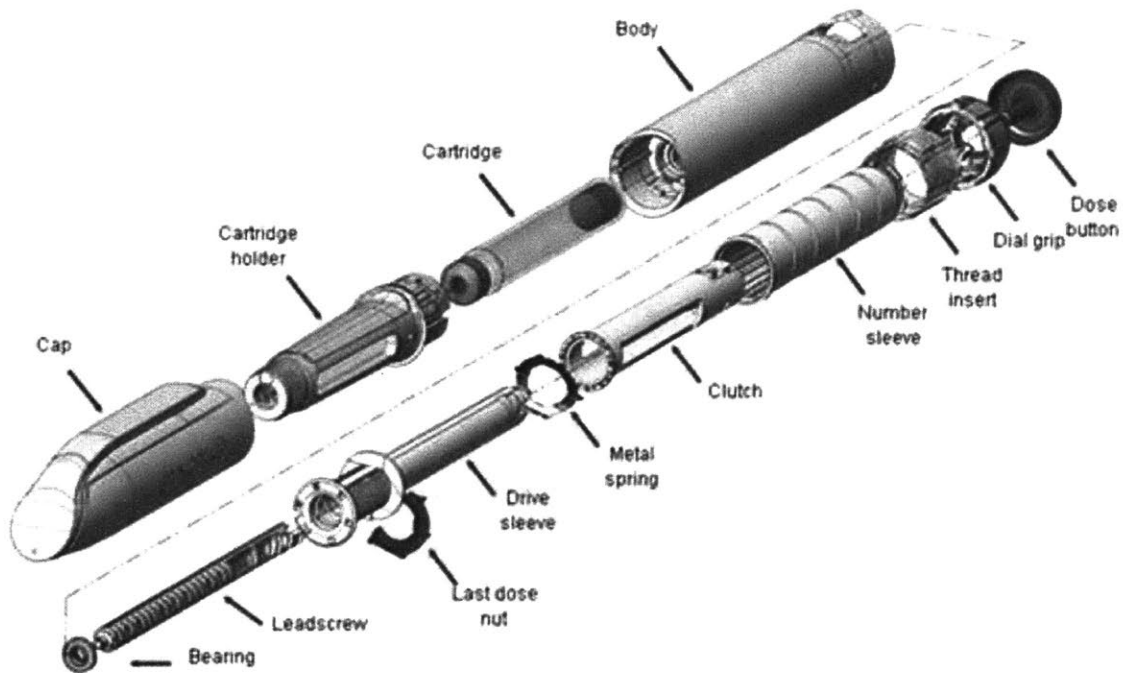

Figure 2-2: Components of SoloStar® Pen

Figure 2-3 shows a graphic of the glass cartridge containing the insulin. The cartridges is capped on one end and a rubber stopper is inserted in the other end to enclose the insulin. The capped end serves as the delivery point, where a double headed needle is inserted through the mesh cap and then below the skin to deliver the insulin.

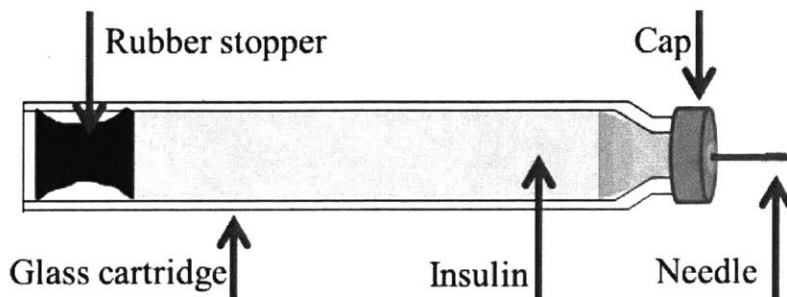

Figure 2-3: Glass Cartridge Components

MED is currently developing the next generation of insulin delivery devices. The next generation pen is called the 3D and it is a slightly modified auto injector. An auto-injector under medical device classification is “a device for injecting oneself with a single, preloaded dose of a drug that typically consists of a spring-loaded syringe activated when the device is pushed firmly against the body” [9]. The 3D pen uses a torsion spring to exert a force on the drive sleeve, which moves the rubber stopper through the cartridge and injects a specified dose of insulin. This differs from a true auto-injector because it does not require a single dose, but can be used multiple times until the cartridge is emptied. Nevertheless, the operating principles are the same as a typical auto-injector. Figure 2-4 shows the components of the 3D pen and demonstrates the added complexity as compared to its predecessor the SoloSTAR®.

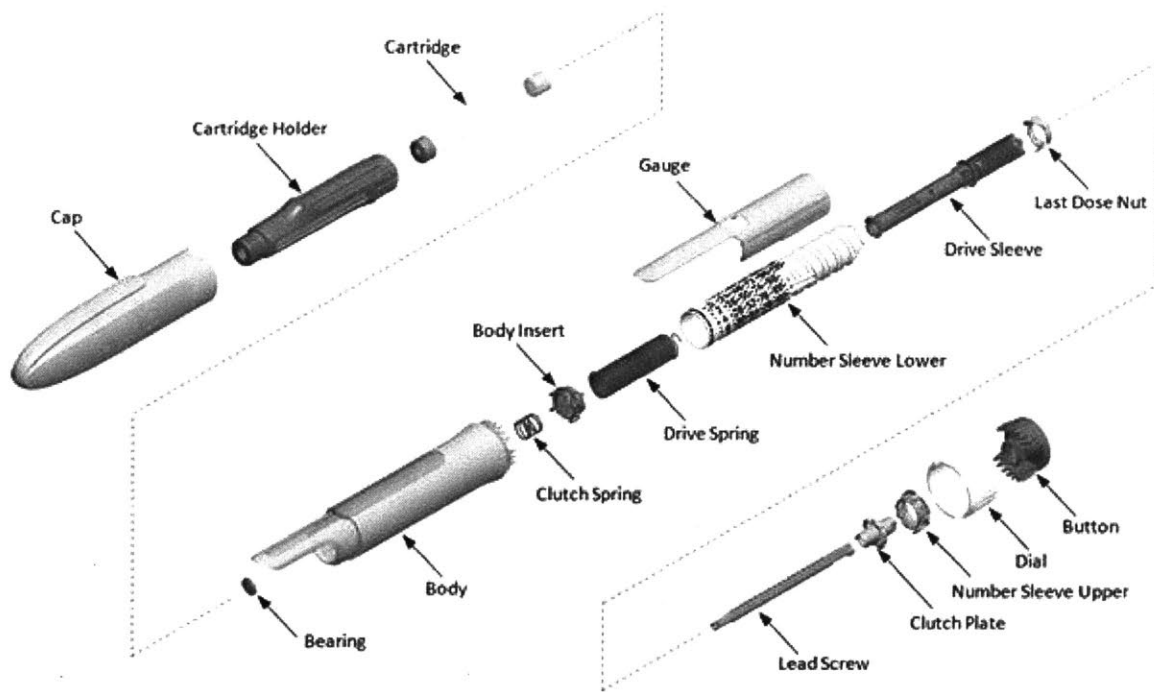

Figure 2-4: Components of the 3D Pen

SFD is responsible for the final assembly of the injection pens. Sanofi's brand reputation is dependent on the performance of the complete device. To ensure robust performance for the device the individual components must also be robust in their production and predictable in their performance. One of the most critical components of the device is the Insulin containing cartridge, which is supplied to SFD by Site Frankfurt Insulin (SFI).

2.2.2 Overview of Sanofi Insulin Production

SFI produces over one million insulin cartridges per day for patients with diabetes. The majority of these cartridges are integrated into the pen delivery systems described above. SFI is the group responsible for filling primary packaging materials with Insulin in the Insulin product production and device integration value chain. The majority of this business unit is focused on production and production related operations, including quality, controlling, and compliance. There are groups within SFI whose focus extends beyond production, including new products, technology implementation, technology transfers and life-cycle management.

In Sanofi's Insulin product profile is Lantus®, Toujeo®, Apidra®, Insuman®, Lyxumia®, and Amyryl®. These products range from long-acting insulin to rapid-acting insulins as well as drugs that stimulate natural insulin production by the pancreas (effective only for Type 2 diabetes) [8].

3 Literature Review

3.1 Baked-in Siliconization of Glass Cartridges

3.1.1 Silicone and Siliconization

Silicone oil has been used in the medical industry for decades and it is the most widely used surface treatment in the industry [10]. Silicone oils have properties that are attractive for medical applications. They are mostly inert and do not react appreciably with biological compounds or initiate a response by biological systems. They are hydrophobic due to their non-polar structure, which limits aqueous mixing and interactions with non-polar drug compounds. They are viscoelastic, which means they exhibit elastic characteristics but increase viscosity during deformation. Under high stress viscoelastic fluids exhibit a solid-like response but under low stress they act as traditional Newtonian fluids [11]. In the context of this application, this means that if significant force is applied to silicone oil it will become more ridged and less effective as a lubricant.

In the relevant application, silicone oil, in the form of a water-dilutable emulsion is applied to the inner surface of glass cartridges prior to filling the cartridge with the desired injectable drug, in this case Insulin. The purpose of this silicone is to lubricate the cartridge during injection, facilitate draining of the product, and provide a barrier layer between the active drug and the glass surface [10, 12]. The protective barrier limits the effects of drug components adsorbing to the glass or impurities from the glass, such as sodium ions, leaching out of the glass and into solution [12]. There are three main types of silicone fluids used for these applications: Non-reactive silicone fluids, non-reactive silicone emulsion, and reactive silicone dispersion [10]. This investigation focuses strictly on the lubrication properties of non-reactive silicone emulsion.

Non-reactive silicone fluids are colorless oils available in varying molecular weights designed by changing chain length. The higher the molecular weight the more viscous the fluid; this results in decreased mobility of the fluid and increased durability [10]. These fluids are typically applied using spraying, dripping or wiping techniques. For cartridge coating the preferred silicon oil product is a non-reactive water-dilutable silicone emulsion. The most common product used in the industry is DOW CORNING® 360 Medical Fluid [12]. Objects coated with non-reactive fluids and emulsions can be baked to remove excess, non-silicon material and further improve cohesion to the substrate and therefore durability [10].

3.1.2 Baked-in Siliconization

The baking process, also called thermal fixation, provides two key advantages. First, it is believed to cause the formation of strong covalent bonds between the glass and the silicone, creating a robust hydrophobic layer. This improves the effectiveness of the silicone as a coating and reduces 'squeeze-out' which is undesirable. "Squeeze-out" is described by the process whereby two solids are in contact, first there is fluid 'trapped' between the rough point contacts between the solids. As time goes on, this fluid (silicone) squeezes out from the asperity contact regions. During this phenomenon the real contact between the rubber stopper and glass increases resulting in higher friction forces [13]. Studies comparing silicone oil coated syringes and baked-in syringes over time have shown significant increase in forces at the beginning of injection for the oil syringes and only minimal increases for baked-in syringes [12, 14]. The difference in performance is attributed to strong bonds formed between the silicone and the glass during baking which keep the silicon adhered to the glass and over time there is significantly less 'squeeze-out'.

Second, thermal fixation reduces the amount of silicone in the cartridge. At the high temperatures reached during baking non-silicone materials and short-chain molecules are vaporized leaving higher viscous silicone in a very thin layer. This layer height is typically on the order of 15-150nm compared to non-baked oil coated surface which is typically 500-1,000nm in thickness [12]. Reducing the amount of silicone needed is important for several reasons. It is believed that silicone promotes aggregation of certain proteins, which could have a negative impact for certain drugs so reducing this effect by reducing silicone amount is desirable [15]. Additionally, if there is more silicone used in coating there is more opportunity for silicone to become free in solution. While silicone is non-toxic it is still not desirable to inject into a patient. Studies have shown the number free droplets found in syringes with baked-in siliconization drops to approximately 10% compared to conventional silicone oil siliconization [14]. Finally, lowering silicone use can reduce manufacturing costs improving the bottom line and making the product more cost competitive.

Some studies have shown that while silicone is heat stable in general, the baking process does lead to some thermal degradation of silicone emulsion. This was observed as a molecular weight distribution shift towards higher molecular weight silicones after heat exposure [17]. This increased viscosity likely has an impact on lubrication properties of the silicone layer. The effect of baking temperature and time on gliding and break lose forces are an interesting topic and one to explore in future work.

3.1.3 Prior LGO Thesis Work on Siliconization at Sanofi

Jeff Schacherl, LGO 2016 investigated the topic of baked-in siliconization and friction force at Sanofi in 2015 [17]. His experiments show several interesting observations and important findings. A design of experiments (DOE) analysis performed on several factors including normal force, linear velocity and silicone spray amount show the directional impact of these parameters on friction coefficient. The majority of analysis was done on flat plate glass using a linear tribometer¹ set up with glass as the substrate and a rubber sphere or rubber stopper as the complimenting material.

¹ Instrument designed to measure the friction coefficient of two materials when set in motion along a single dimension (x-axis) with a specified normal force and linear velocity.

In support of intuitive theories, the DOE results confirmed normal force and linear velocity have significant effects on friction coefficient. More interesting, the DOE suggests an exponential relationship between friction coefficient and baked-in siliconization amount. At very low levels of baked-in silicone, the friction coefficient increases significantly, however, once a minimum is reached, the further increase in baked-in silicone amount does not lead to a significant decrease in the friction coefficient. This minimum layer was found to be 40% of the nominal spray amount (Figure 3-1).

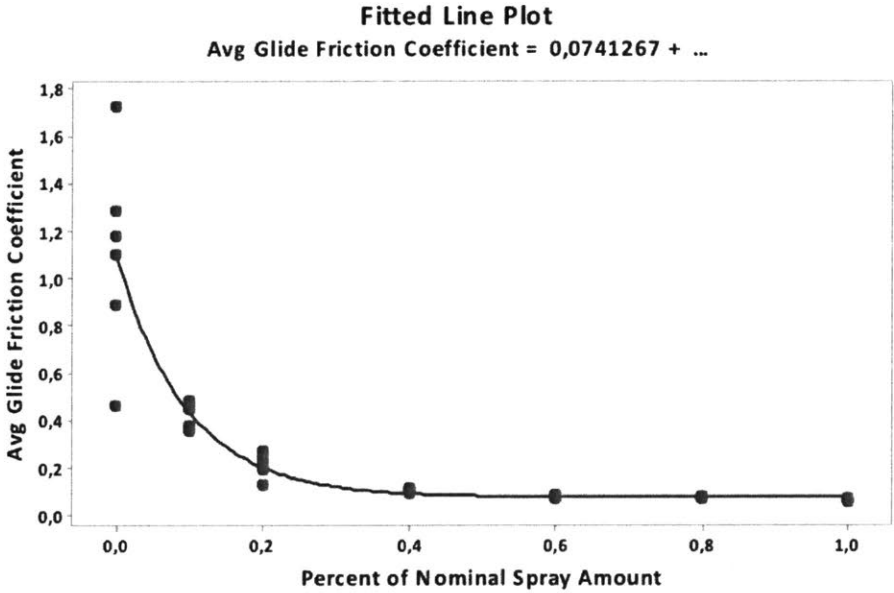

Figure 3-1: Effect of Silicone Amount on Friction Coefficient

Additional experiments carried out show that dry spots² have a significant impact on friction coefficient. The size of the dry spot has an impact on the magnitude of friction coefficient increase and Schacherl suggests opportunities to quantify that effect based on size and geometry of the dry spot. Testing was expanded to linear tribometer testing on curved glass samples, taken from production and modified, in order to more closely simulate and measure the real application. Measurements confirmed friction coefficient values in the same regime as flat plate glass samples and similar trends were observed with dry spots that were identified on one sample from production [17].

² Dry spots are defined as areas on the glass where little or no silicone is present.

3.2 Nanotribology: Friction and Lubrication

3.2.1 Friction

The study of friction on the atomic level, known as nanotribology has been studied since the late 1960s but more progress has been made in the last decade with ever improving technology, analytical equipment and computer simulations [18]. It is fundamentally important when investigating the interactions of two materials with a lubrication layer to explore the molecular interactions.

The industry standard for checking the effective lubrication of a siliconized cartridge is by measuring break loose and gliding forces. The break loose force is the force needed to put the rubber stopper in motion from a stationary state. The gliding force is the force needed to move the stopper through the cartridge during injection [14]. Break loose force is analogous to static friction and gliding force to dynamic friction. There are two major sources of opposing forces that counteract the break loose and gliding forces: friction force and hydrodynamic force. These can be visualized in Figure 3-2 below. The hydrodynamic force is fairly well understood as a function of needle length and diameter and is not the focus of this investigation. The friction force is heavily influenced by the silicone distribution inside of the cartridge and is the subject of this investigation.

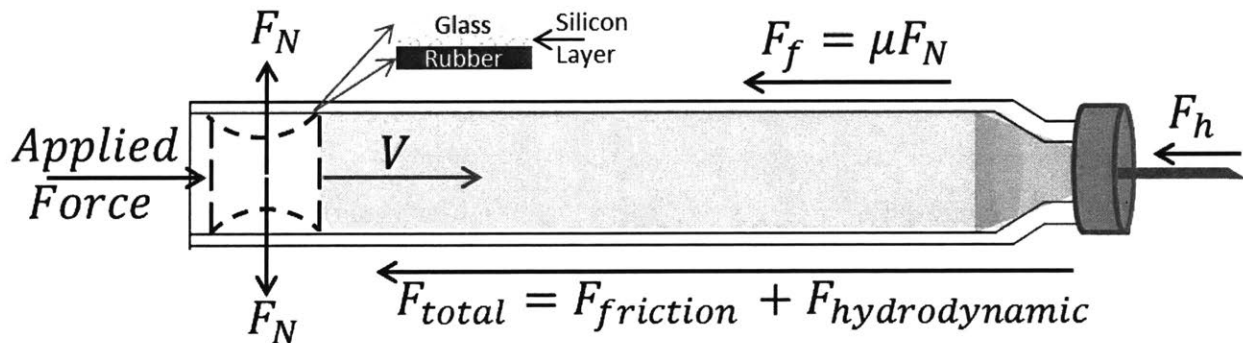

Figure 3-2: Simplified force diagram during injection | adapted from [19]

Break loose and gliding force measurements are easily performed in production settings and with common test equipment; however, they are often not sensitive enough to understand the full picture, especially on the nanoscale. On a very fundamental level, friction has been described by Equation 3-1, where μ is the coefficient of friction which is constant for a specified set of materials under specified conditions [20].

$$F_{friction} = \mu F_{normal} \quad (3-1)$$

A more microscopic view of friction reveals that friction is dependent on the real area of contact and the yield stress of individual points of contact, called asperities, during movement or shear. This relationship can be understood with Equation 3-2:

$$F_{friction} = T_c A_{real} \quad (3-2)$$

where T_c is yield stress during shear and A_{real} is the real contact area. Knowing the proportionality between true contact area and friction force, it must be that the real contact area of a material is linearly dependent on the normal force of that material [20]. This becomes an important relationship when dealing with friction force investigations in which there are varying normal forces.

3.2.2 Lubrication

Friction can be reduced by lubrication. In the application being investigated the silicone is the lubricant between the glass cartridge and the rubber stopper. There are three regimes used to describe lubricated or 'wet' friction and these are best visualized by the Stribeck diagram (Figure 3-3).

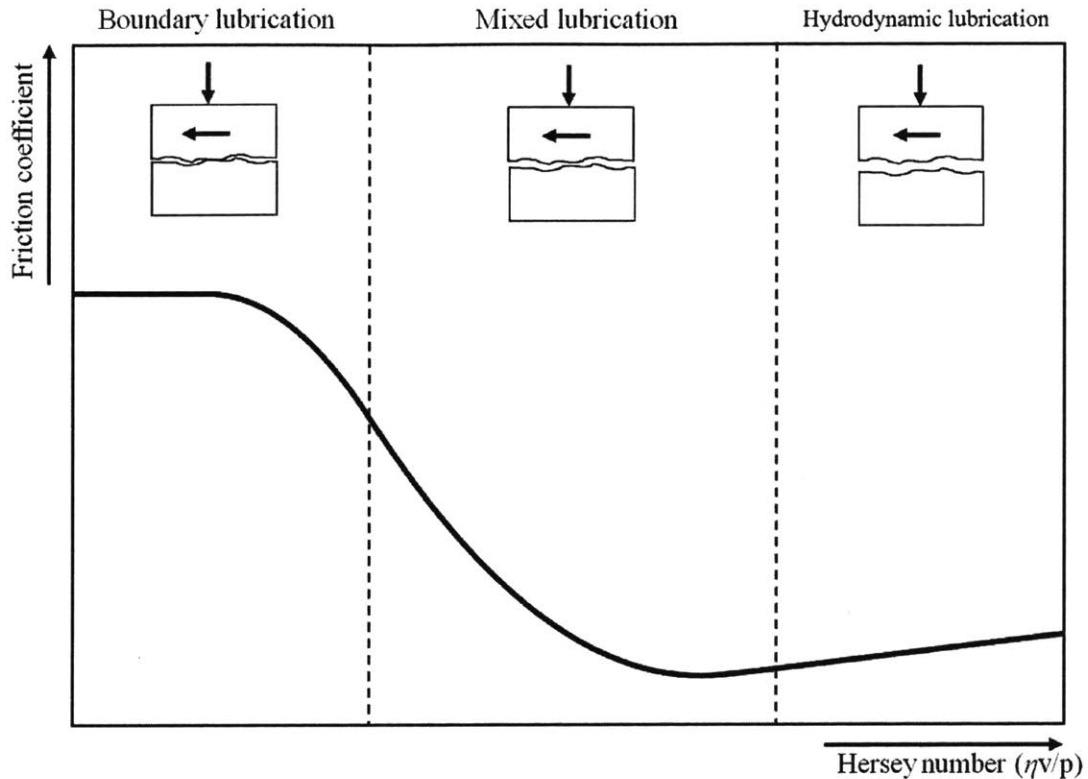

Figure 3-3: Stribeck Diagram [21]

Figure 3-3 plots the coefficient of friction (μ) against the Hersey's number defined as:

$$\text{Hersey's Number} = \frac{\eta * v}{P} \quad (3-3)$$

where η is the fluid viscosity, v is the velocity and P is the contact pressure or load. The three regimes are boundary, mixed lubrication and hydrodynamic. In boundary lubrication the lubrication layer is not sufficient to separate the two surfaces completely. In hydrodynamic lubrication there is a sufficient layer of lubrication larger than the materials' roughness, such that the materials themselves do not come into contact during movement. Mixed lubrication is used to describe an environment that is somewhere between the boundary and hydrodynamic conditions [20].

From a theoretical perspective, surface roughness and lubricant thickness dictate which operating regime a specific application is in. Each of these ranges can be described by λ , the ratio of lubricant film thickness to the combined surface roughness of materials and seen in Table 3-1 [22]. Baked-in siliconization has not been described using this framework in literature, but it is possible that it spans all three regimes due to the reality that lubricant thickness varies throughout the cartridge.

Table 3-1: Stribeck Regimes [22]

Lubrication regime	Ratio of lubricant film thickness to the combined surface roughness (λ)
Boundary	$\lambda < 1$
Mixed	$1 < \lambda < 5$
Elastohydrodynamic*	$3 < \lambda < 10$
Hydrodynamic	$5 < \lambda$

*The elastohydrodynamic regime is used to describe a liquid's behavior under which it exhibits both elastic and Newtonian properties.

In general, viscosity is the most important property of a lubricant and usually used to characterize lubricants. However, it is clear that surface roughness plays an important role in lubricant effectiveness. Literature states that “in lubricated systems, rough surfaces tend to produce higher friction.” This suggests an opportunity to reduce friction if the material roughness can be decreased [20]. The Stribeck diagram nicely supports the discussion about the ‘squeeze out’ effect discussed in Section 3.12 where increased friction due to ‘squeeze out’ becomes more prominent under higher normal forces.

In a hydrodynamic lubrication state, friction becomes linearly dependent on velocity and nearly independent of normal force. This relationship is derived from the Navier-Stokes's equation and is represented by the Equation 3-4 describing friction force for two solids with parallel planar surfaces sliding over one another with a film of lubricant.

$$F_F = \frac{A}{d} * \eta * v \tag{3-4}$$

For cylindrical geometry this can be extended.

$$F_F = \frac{\pi r^2}{d} * \eta * v \tag{3-5}$$

Under low pressures, viscosity is independent of pressure; however, a further expansion of this takes into account the change in viscosity of the lubricant caused by pressure change. Increased pressure on the lubricant comes from increased normal force.

$$F_F = \frac{\pi r^2}{d} * \eta_0 e^{\alpha P} * v \quad (3-6)$$

Where η_0 is viscosity at $P=0$ and α is a constant. The assumptions that govern Equations 3-4, 3-5, 3-6 are that an even layer of lubricant exists, fluid flow is laminar and the fluid is a Newtonian fluid.

Not knowing which lubrication regime exists for this application, a single theory cannot be relied upon in isolation to describe the behavior; however, these mathematical descriptions can be used to gain better insight into the friction properties observed.

3.3 Optimization

The existing literature characterizes the siliconization process as “having decisive influence [on force parameters]” but qualifies that statement by saying “silicone coating that is too thin or uneven can impair the syringe’s mechanical function. Vice-versa, too much silicone oil can in some circumstances result in free silicone oil droplets forming.”[14]. A common objective in the siliconization process is to “reduce the quantity of silicone oil to the minimum level possible without impairing the syringe’s [or cartridge’s] mechanical function.” Other qualifications, some specific to the process of siliconization include: “It is clear that there is no universal solution for syringe function [14],” and “siliconization is a complex process” [23]. These qualifying statements show that the desired factors of a siliconization profile are intuition driven at best and not well understood. The ability to achieve a desired change or characteristic, a uniform thickness for example, has been investigated with pilot siliconization spray systems in at least one published study.

In this study, a DOE was carried out to investigate effects of nozzle spray range, nozzle retraction speed, silicone-coated amount and air-to-nozzle pressure. The criteria used to determine effective coating was visual inspection using glass powder and gliding forces. The key findings are mostly applicable only for the specific test set-up used but some findings can be extended to general siliconization and potentially baked-in siliconization. First, the nozzle retraction is important for even distribution and the faster the retraction, the less uniform the coating. Second, finer droplets, created by heating the silicone oil and increasing the atomizing air pressure, contribute to an even silicone distribution [23].

Beyond this study, few efforts published in literature have been made to describe optimization of the siliconization process applicable for a process at the manufacturing scale.

3.4 Atmospheric Pressure Plasma

Atmospheric Pressure Plasma (APP) when applied to a substrate surface removes organic contaminants using charged radicals. APP is a group of electrically charged particles produced at or around atmospheric pressure. These charged particles are both positive and negative such that the collective medium is nearly neutral. Plasma surface treatment has become increasingly important in many industries over the past 20 years including electronics, aerospace, biotechnology and medical device [24]. The main advantage of *atmospheric* pressure plasma treatment over vacuum pressure plasma treatment is that it can be done without enclosing the system in a pressure or vacuum chamber. This enables plasma systems to be integrated into manufacturing lines at reasonable cost.

There are several different ways to generate and apply APP to a substrate. These include microwave, radio frequency, dielectric barrier discharge and gliding arc discharge using AC or DC [24, 25]. Plasma generation can be retrofitted to many different applications as different plasmas interact with different substrates in different ways. The general effect of APP is a 'super cleaned' surface with increased surface energy.

By exposing a glass surface to APP, the charged particles and radicals in the plasma remove organics by chemically ‘pulling’ them off the substrate surface. Figure 3-4 demonstrates this cleaning action. This APP effect makes the glass substrate cleaner, more uniform and in doing so increases the surface energy and wettability. Another advantage is that this treatment does not modify the bulk material so the glass is not changed [26].

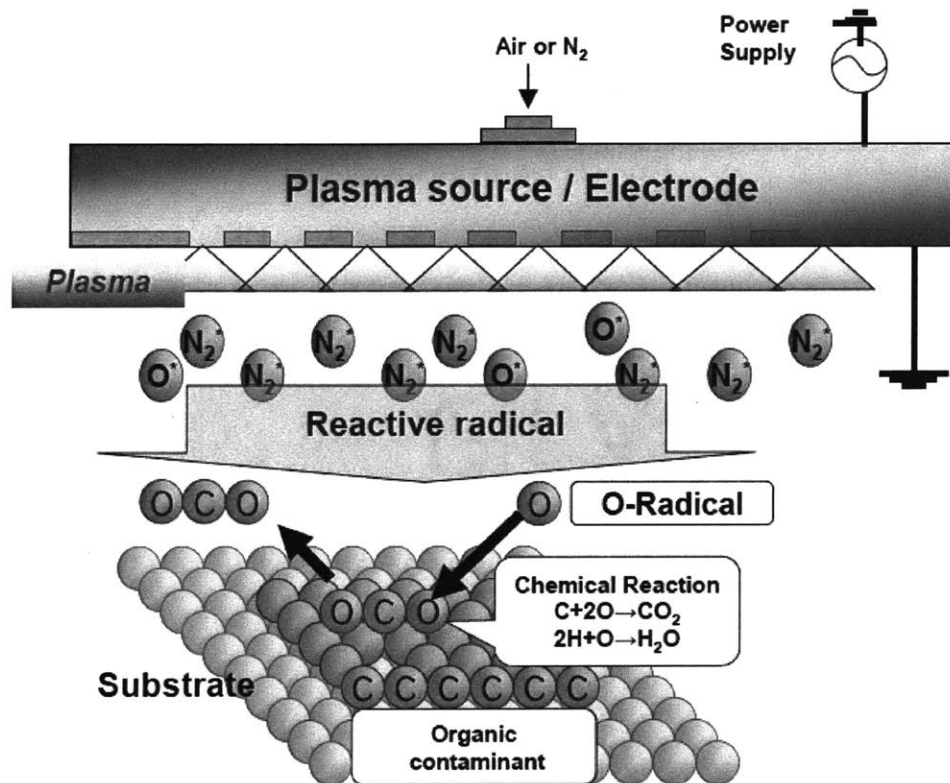

Figure 3-4: APP Operating Principle [27]

Surface energy is a measure of intermolecular forces on a substrate’s surface and the degree to which it attracts other material [28]. Wettability is the degree to which a liquid spreads or adheres to a surface and can be observed by measuring the contact angle of a liquid droplet placed on the substrate [29]. Surface energy and wettability are proportional to one another, as surface energy increases, so does wettability. Figure 3-5 demonstrates the effect APP has been shown to have on wettability of a glass substrate [25].

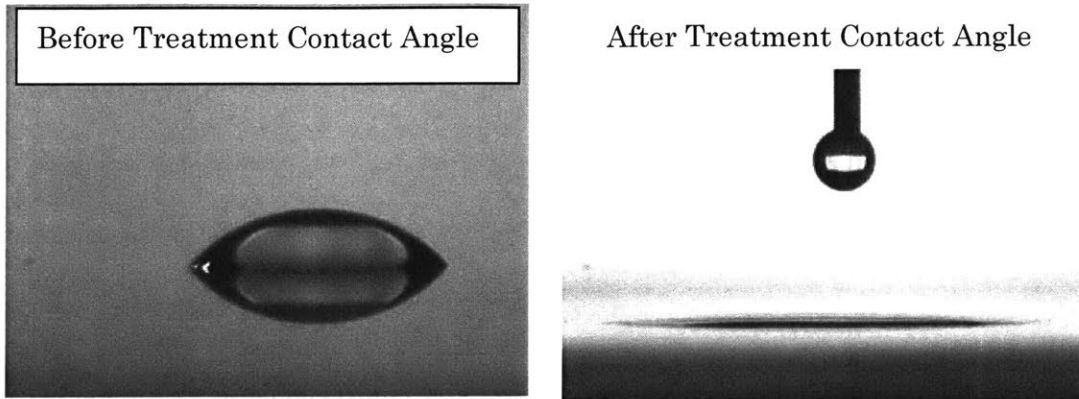

Figure 3-5: Wetting Effect [27]

The application of interest here is APPs effect on the glass, specifically the inner surface of glass cartridges. The hypothesis is that an APP treated surface applied with silicone should have a more uniform and evenly distributed surface layer of silicone.

4 Data Collection Techniques

4.1 Core Analytical Techniques

Samples were analyzed using two main analytical techniques designed to gather data about the silicone layer profile and resulting friction forces produced by each method of siliconization. The first technique, reflectometric interference spectroscopy and interferometry, analyzes the thickness layer of the silicone at specific intervals to provide a 'picture' of what the silicone profile looks like [30]. The instrument providing this analysis was produced by rap.ID and is discussed in detail in Section 4.2 and 4.4.1. The second technique uses a pressure sensor to measure force resistance during simulated injection of a cartridge, where a rubber stopper is pushed through the cartridge at constant velocity. This technique is described in detail in Sections 4.3 and 4.4.2.

4.2 Surface Layer Spectroscopy

The rap.ID Layer Explorer is an instrument used to measure the thickness and distribution of silicone inside a syringe or cartridge. The thickness is calculated by measuring the interference pattern of light obtained with a spectrometer. The traditional method can be used to accurately determine thicknesses as low as 80nm. Additional functionality is provided by the ultra-thin measurement equipment, which allows for measurements down to 20nm using laser interferometry [30]. Both methods used in conjunction provide the data used in the following analysis.

The output of measurements is displayed pictorially to visualize the inner surface profile of the cartridge using color-coded thickness ranges. Examples from measurements taken of samples from the filling lines can be seen in Figure 4-1. This analytical tool is critical to understanding what layer profile is being produced from the siliconization and baking processes of filling lines and siliconization systems.

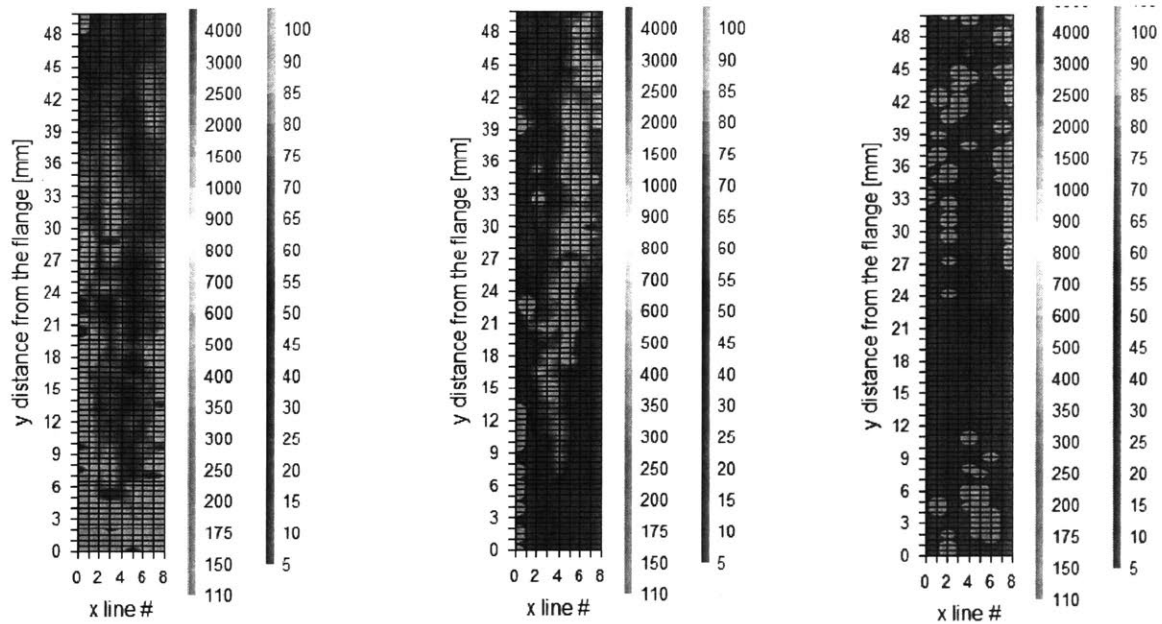

Figure 4-1: Example Layer Explorer Measurement Outputs

4.3 Friction Forces Testing

As previously discussed in Section 3.2.1 the industry standard for measuring friction forces in cartridges is break loose (static) and gliding (dynamic) forces. At SFI, these are currently measured as quality process control (QPC) checks at regular intervals during production. The current in process QPC method as of July 2016 measures the force profile over the length of the cartridge during simulated injection at a constant velocity of 45mm/min. The cartridges tested are collected from the end of the filling process so they are filled with Insulin and capped. To simulate injection, a standard 29 gage needle of length 12.7mm is inserted into the cap to allow liquid to flow out of the cartridge and a piston applies a force at constant velocity to the rubber stopper [31]. The force profile is therefore the resistive force to movement of the rubber stopper through the cartridge. A simplified force profile for a cartridge measured using this method can be seen in Figure 4-2.

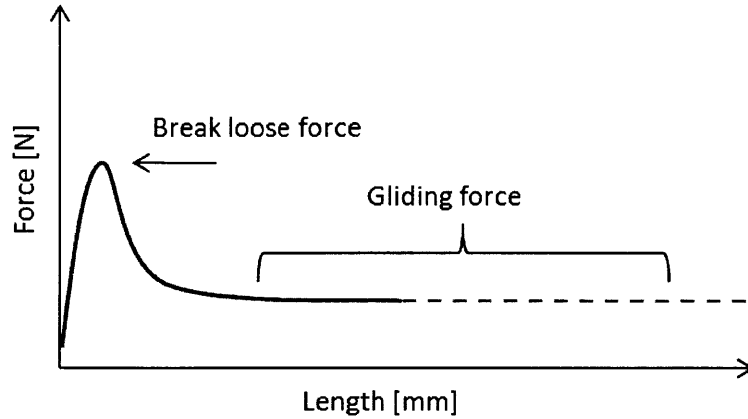

Figure 4-2: Simplified Force Profile for Cartridge during Injection

Two main effects create the resistive force on the rubber stopper and these are hydrodynamic force and friction force. While other phenomena contribute to the resistive force, subcutaneous resistance for example, their impact is negligible and the simplified total resistive force can be described by Equation 4-1. If flow of the Insulin is assumed to be laminar and Newtonian then the hydrodynamic force can be described by Equation 4-2, using the Hagen-Poiseuille law and shown to accurately predict hydrodynamic force in syringes [19].

$$F_{total} = F_{friction} + F_{hydrodynamic} \quad (4-1)$$

$$F_h = \left(\frac{8\pi\eta L r_b^4}{r_n^4} \right) V \quad (4-2)$$

where η is the viscosity fluid, L is the needle length, r_b is the cartridge inner radius, r_n is the needle inner diameter and V is the velocity of injection.

In order to focus this investigation specifically on the friction forces, force measurements were performed on empty cartridges in order to remove hydrodynamic effects in an attempt to isolate friction resistance forces. Testing velocity used was chosen to be 150mm/min based on device use velocity in the range of both current injection pens and spring driven pen systems. The effects of testing speed and testing with and without a needle were observed empirically. These effects are displayed and discussed in Appendix C.

While this testing aims to isolate the friction force so that relationships can be developed between friction force and silicone layer profile, there are other factors that cannot be eliminated using the described test set up. One important source of error is dimensional differences in the testing components, specifically the glass cartridges and the rubber stoppers. The magnitude of this source of error can be approximated and those impacts are discussed in Appendix D.

4.4 Data Computation and Comparison

4.4.1 Rap.ID® Layer Explorer

The Layer Explorer measures layer thickness at single positions along the cartridge according to the method specified. The raw data produced is therefore a collection of individual data points. These data points are organized and analyzed to provide a variety of quantifiable characteristics which define the silicone profile. These characteristics are listed and defined in Table 4-1.

Table 4-1: Silicone Profile Characteristics

Metric	Description
Overall mean layer height [nm]	Average value from all measurement points
Overall max layer height [nm]	Maximum value measured in cartridge
Overall min layer height [nm]	Minimum value measured in cartridge
Overall layer height standard deviation [nm]	Measure of variation among measurements
Range of layer height [nm]	Difference between max and min data points
Mean layer height top, middle, bottom [nm]	Average layer height from top, middle and bottom sections of the cartridge divided equally in thirds
Quantity and percent of dry spots [#, %]	Number and percent of data points measured below a specified minimum (30nm)
Quantity and percent of LLD data points [#, %]	Number and percent of data points measured below the lower limit of detection (20nm)

Because the layer explorer has a lower limit of detection (LLD) of 20nm, the points identified as ‘below the level of detection’ were replaced with an assumed thickness height to allow for quantitative analysis. 10nm is an obvious choice as it is the middle point between 0 and 20nm and was used to replace any LLD data points for quantitative analysis. The criteria for what consists of a ‘dry spot’ is a topic for further discussion but for this investigation a dry spot was defined as any data point with a thickness measured below 30nm. This includes all LLD data points and data points measured below 30nm.

In addition to these metrics, a method to identify large ‘dry spot’ clusters within a data set would provide valuable information to make determinations about size and geometry of dry spots and their impact on friction. This method was not, however, developed during this investigation.

4.4.2 Zwick® zwickiLine Test Equipment

As already discussed in Section 4.3 and Appendix C and D the gliding forces measured include a significant source of error. Therefore, while it is possible to investigate cartridges based on an individual force profile it is more reliable to look at general trends of sets of force measurements. These metrics are listed and described in Table 4-2.

Table 4-2: Characteristics of Fiction Force

Metric	Description
Average gliding force [N]	For a set of data of n cartridges measured using the Zwick, the average of each cartridge’s average gliding force during simulated injection.
Average break loose force [N]	The average of each cartridge’s break loose force
Average maximum gliding force [N]	The average of the maximum force encountered by each cartridge during gliding
Standard Deviation on max force [N]	The standard deviation of maximum force encountered during gliding for a given data set of n cartridges
Standard Deviation on average gliding force [N]	The standard deviation of average gliding force for a given data set of n cartridges
Absolute Max [N]	The highest friction force encountered by a single cartridge in the data set

Some efforts were made to correlate specific silicone profiles to friction force effects but the sources of error limited these efforts mostly to exploratory work. There are clear examples where the silicone profile can be tied to friction effects as demonstrated by Figure 4-3.

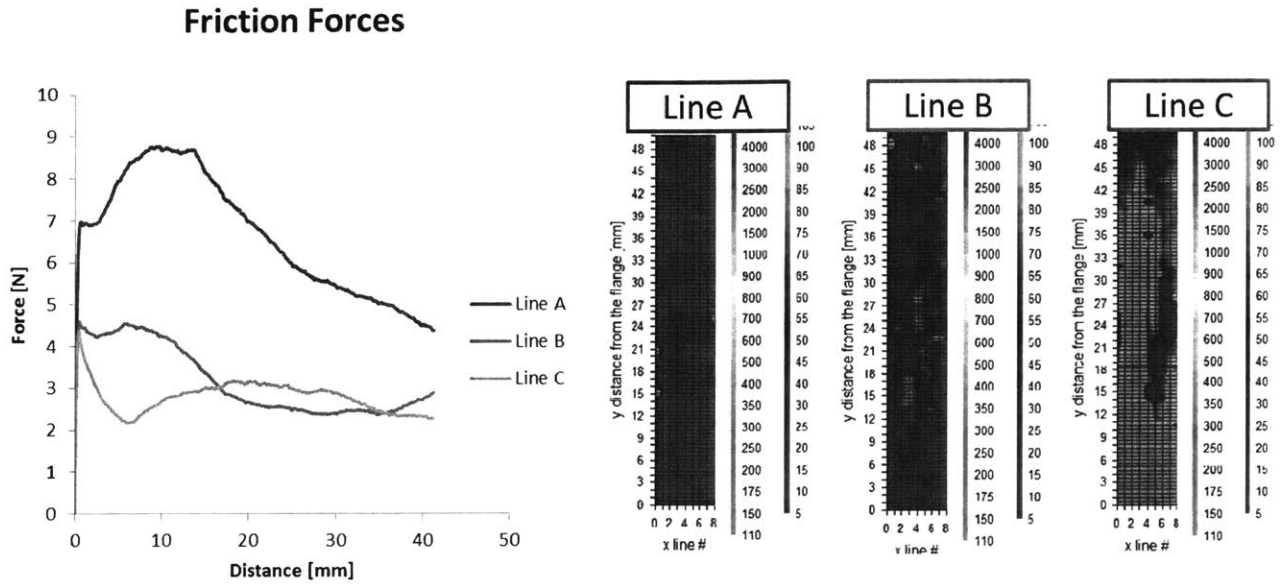

Figure 4-3: Correlating Silicone Profile to Friction Forces

While these correlations appear clear and consistent, there are several other examples where the silicone profile, characterized in the context of the rap.ID layer explorer data, does not accurately predict or agree with the friction force profile. This is an opportunity for future work and will be discussed in detail in Chapter 8.

5 Current State Filling Line Analysis

5.1 Data Collection and Sampling Procedure

At Sanofi Deutschland there are several filling lines for Insulin cartridges. Due to development and growth of the business these lines have been added or upgraded over the past 25 years. The result is filling lines with different equipment and different processes, though all lines produce similar products and satisfy internal company and outside regulatory requirements. Three different methods exist for siliconization. These methods are: 1) flushing system, 2) time-pressure system and 3) micro dose system and will be referred to as Line A, B, C respectively.

Looking at a representative filling line with each method allows for the analysis of the different systems and their corresponding siliconization profiles and resulting friction performance. The results of this investigation show that differences exist between the methods.

The first steps of the filling process include washing, siliconizing and baking. These process steps for siliconization with each method are outlined shown in Figure 5-1 and described step by step in Appendix E. There are several differences in process parameters and set points but the main difference between systems is how the silicone is sprayed into the cartridge. These parameters and this information were aggregated to compare differences and assess potential impacts.

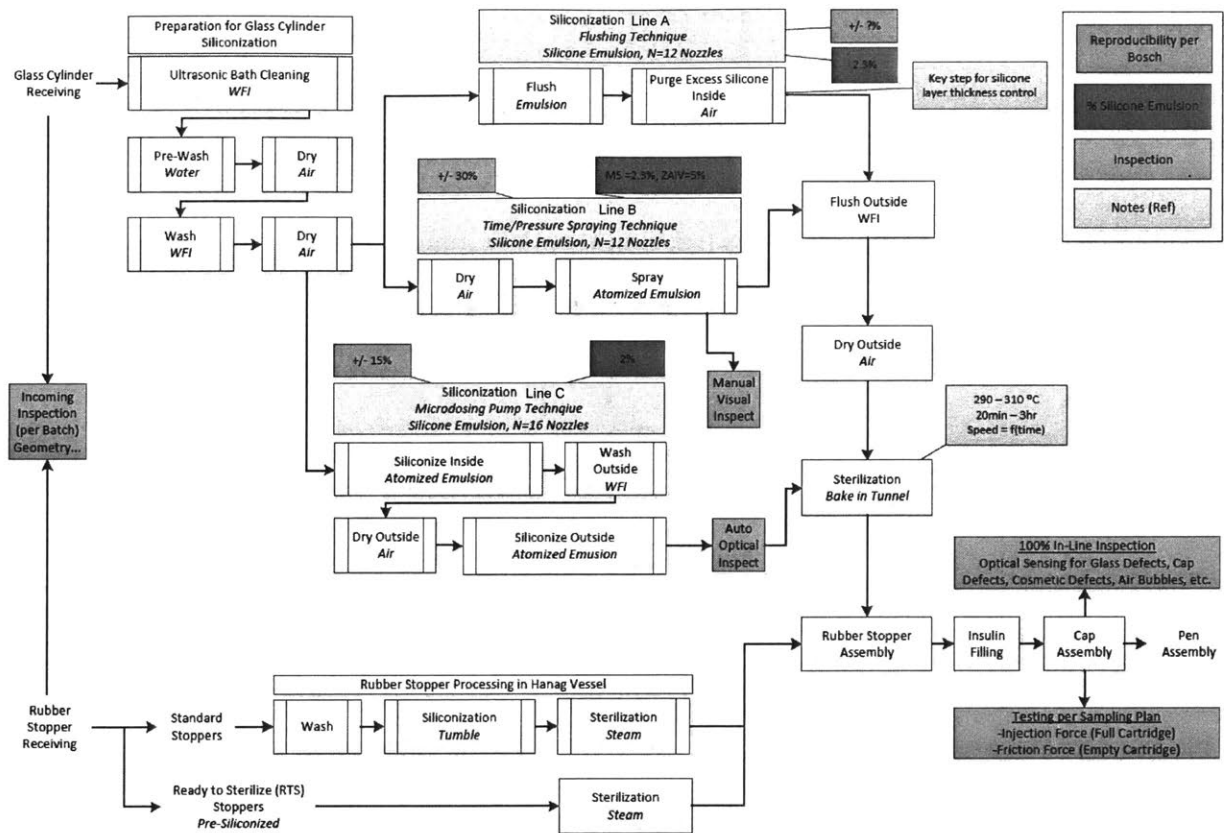

Figure 5-1: Process Diagram of Filling Process at SFI [17]

In the flushing system (Line A), an excess amount of silicone emulsion is sprayed into the cartridge with a ‘diving needle’ that travels down, out of the cartridge as it sprays emulsion (Figure 5-2). Another needle then blows compressed air inside the cartridge to remove the excess silicone with the same diving movement. This step lasts between 2-3 seconds. In the pressure time system (Line B), silicone emulsion is atomized with compressed air and sprayed into the cartridge with a short nozzle from below the cartridge (Figure 5-3). The micro dosing system (Line C) is a sort of hybrid system that delivers a specified amount of silicone emulsion to a cartridge through atomization and with a ‘diving needle’.

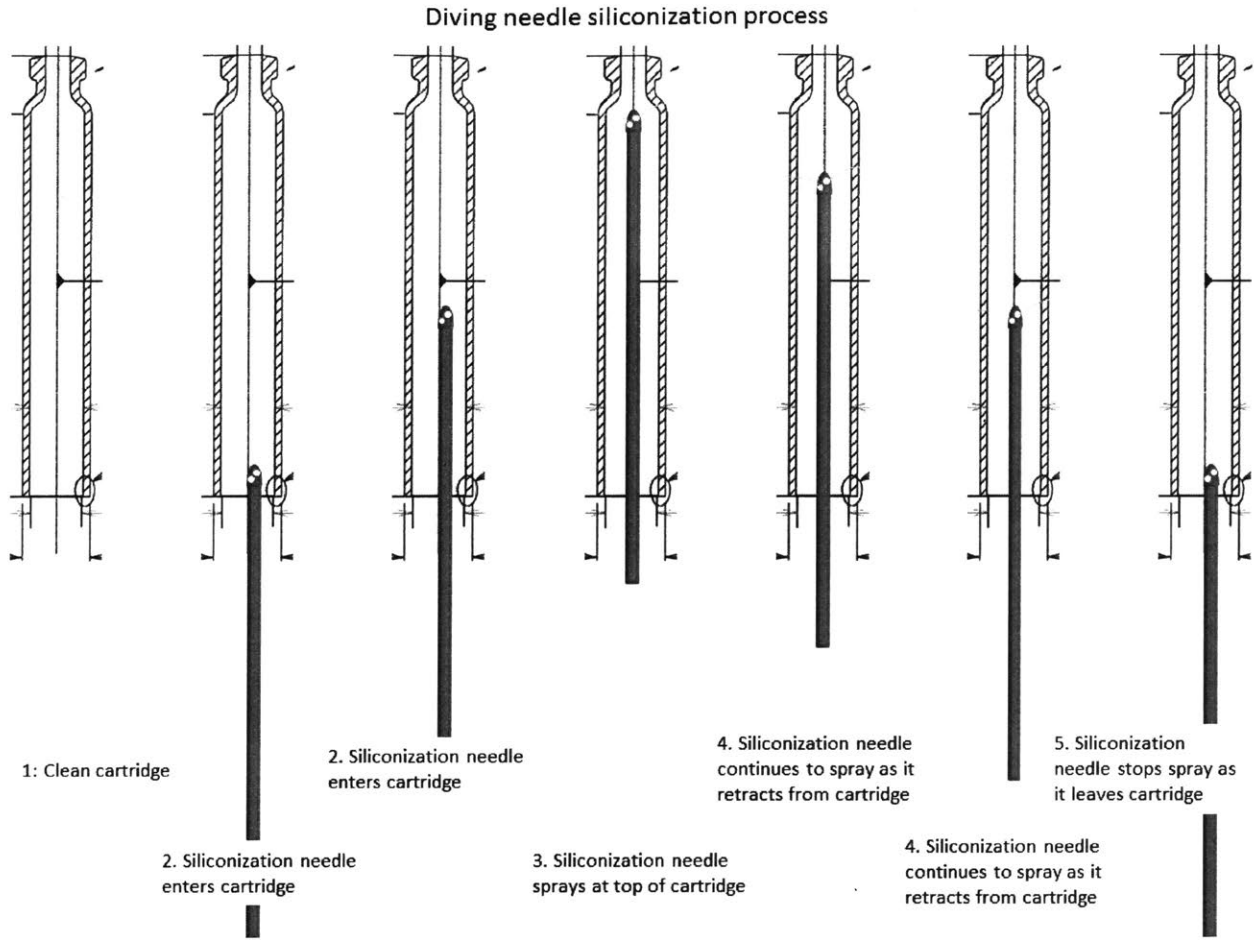

Figure 5-2: Diving Needle Process

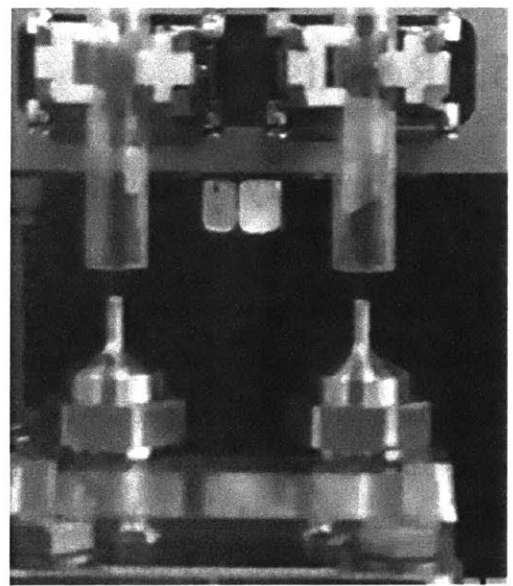

Figure 5-3: Micro-dosing Siliconization (left) and Pressure-time Siliconization (right)

Samples were collected during two separate batch production runs from each representative filling line. The samples included Insulin filled cartridges from the end of the filling line and siliconized cartridges collected from after the heating/baking tunnel. All samples collected were 3.0ml cartridges and were stored upright in cartridge boxes (Figure 5-4).



Figure 5-4: Sample Cartridge Box

From these samples collected, the siliconization profile and friction performance were evaluated using the analytical techniques described in Chapter 4.

5.2 Results

5.2.1 Summary of Results

For the filling lines characterized there exist several distinct differences in the process of siliconization. Due to these differences, results of characterization show differences in silicone layer profile and subsequent friction forces. Filling line A, equipped with the flushing system, showed the lowest average silicone layer height, highest number of dry spots and the largest friction forces and variability in friction forces. Filling line C, the micro dose system showed the highest average silicone layer height, fewest dry spots and the lowest friction forces and friction force variability. Filling line B showed a silicone profile and friction forces in the middle of line A and C.

5.2.2 Silicone Profile

Each filling line has a characteristic silicone profile. Figure 5-5 shows a typical siliconization profile for filling lines A, B and C respectively. Within the data set analyzed there is variability among silicone profiles; however, there are trends among a particular filling line and differentiating characteristics between the filling lines. The entire data set of images can be seen in Appendix B.

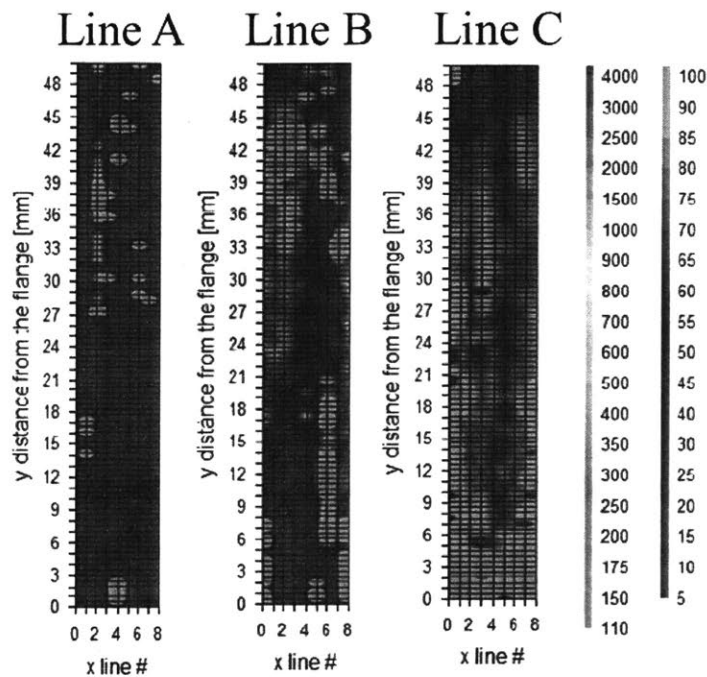

Figure 5-5: Characteristic Silicone Profile for Filling Lines A, B, C

The noticeable visual difference here is that line C has better silicone coverage than line B which has better silicone coverage than line A. In addition to these observations, there are differences between the first and second data sets when comparing the profiles produced from an individual line. For example, shown in Figure 5-6 is a characteristic profile of a cartridge siliconized on line C from the first and second data set. These differences can be attributed to slight differences in production from one batch to another or from measurement variation. To control for measurement error within a data set, samples from each line were randomized prior to measurements. The characteristics reported here include averages from all measurements taken (20 per filling line).

Line C

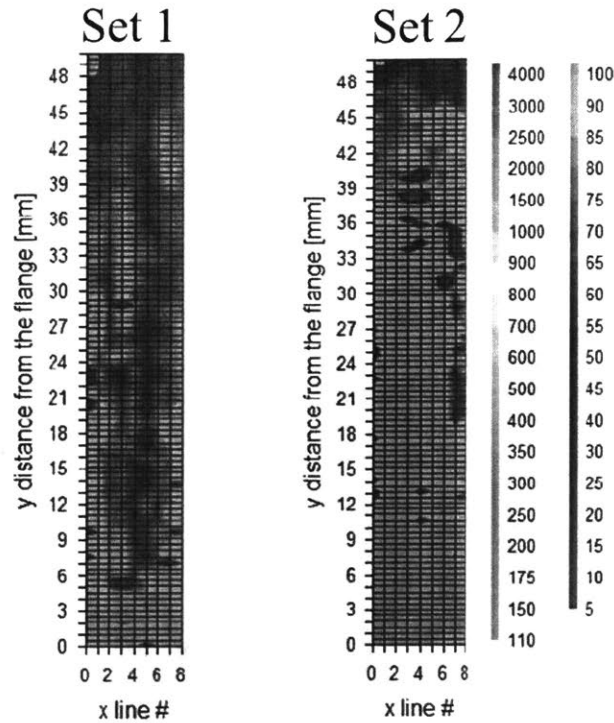

Figure 5-6: Example Differences in Silicone Profile Between Data Sets

Two of the most descriptive characteristics of the silicone profile, average layer height and percent of dry spots, are quantifications of silicone layer thickness. Figure 5-7 compares average layer height between lines A, B, and C. Figure 5-8 compares the average dry spots for lines A, B, and C.

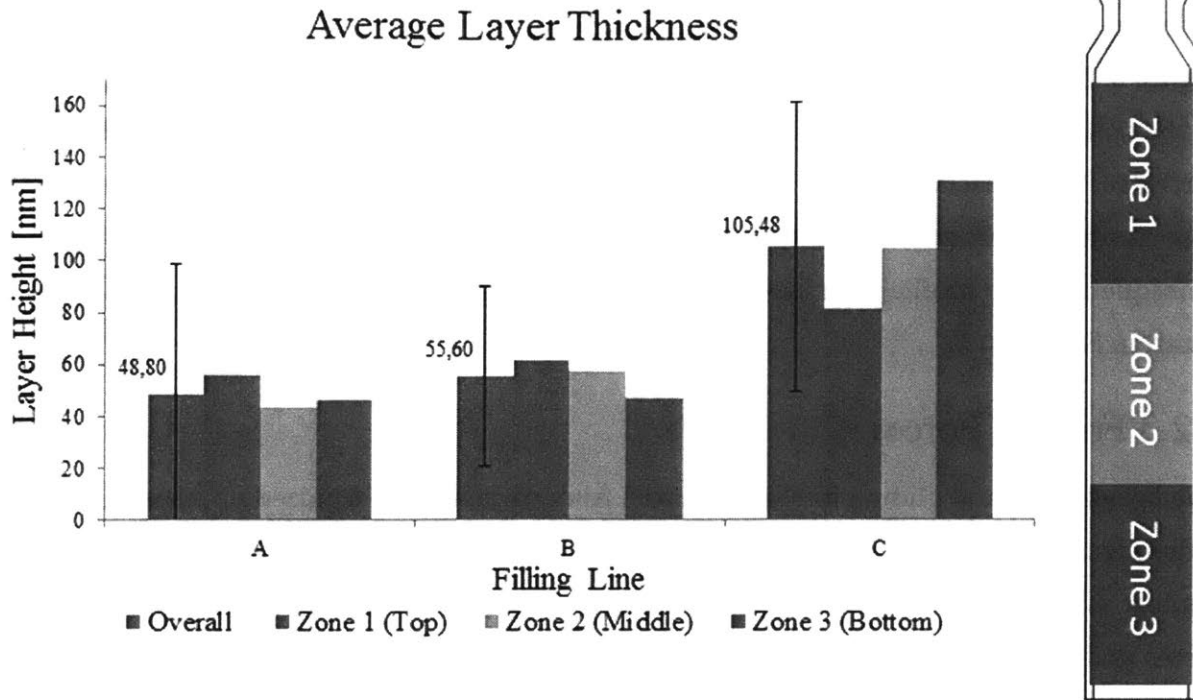

Figure 5-7: Silicone Layer Height in Cartridges

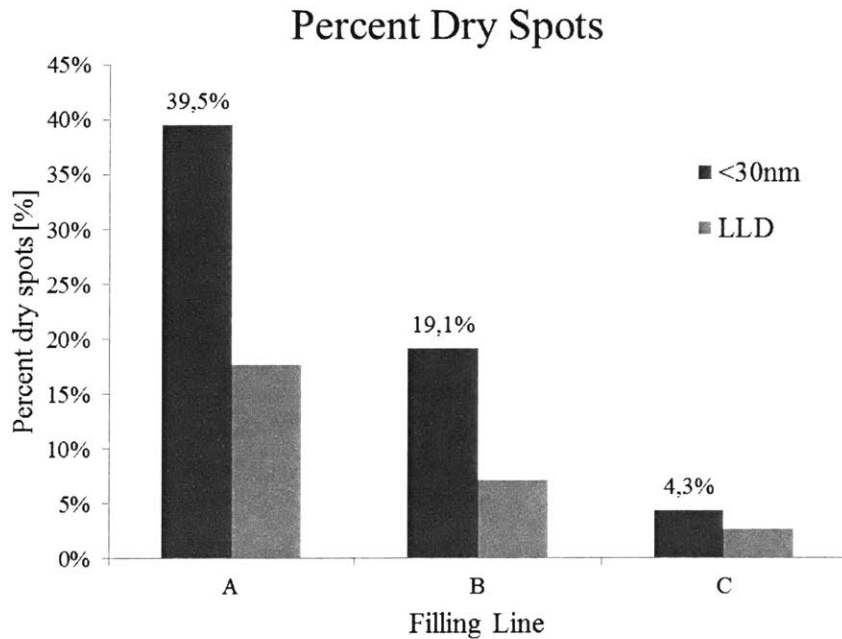

Figure 5-8: Dry Spots in Cartridges³

³ LLD stands for lower level of detection. This is the percent of data points that were not able to be measured using reflectometry, indicating the silicone is either not present or below 20nm in height.

Further differences in layer height profiles can be observed by hypothetically breaking the cartridge into segments and measuring average layer height. The results are shown in Figure 5-7. For line C there is a strong pattern that shows a thicker silicone layer present at the bottom of the cartridge with less silicone present at the top (needle-end) of the cartridge. This observation can be attributed to current parameter settings with an opportunity to influence the distribution by changing those parameters. The potential consequences of a profile with less silicone near the needle end will be discussed in more detail in Section 5.3.

5.2.3 Friction Forces

The break loose and gliding forces measured from cartridges siliconized on lines A, B, and C differ significantly from one another and can be seen in Figure 5-9. Line A shows the highest average forces for all metrics including variability, line C has the lowest friction forces and variability and line B measures in the middle between lines A and C. The most striking observation is the degree of variation seen in lines A and B compared to C. From a production, quality and design perspective, the gliding forces produced from line C cartridges have the tightest control, which is a desirable characteristic.

Friction Forces [V=150mm/min; N=20]

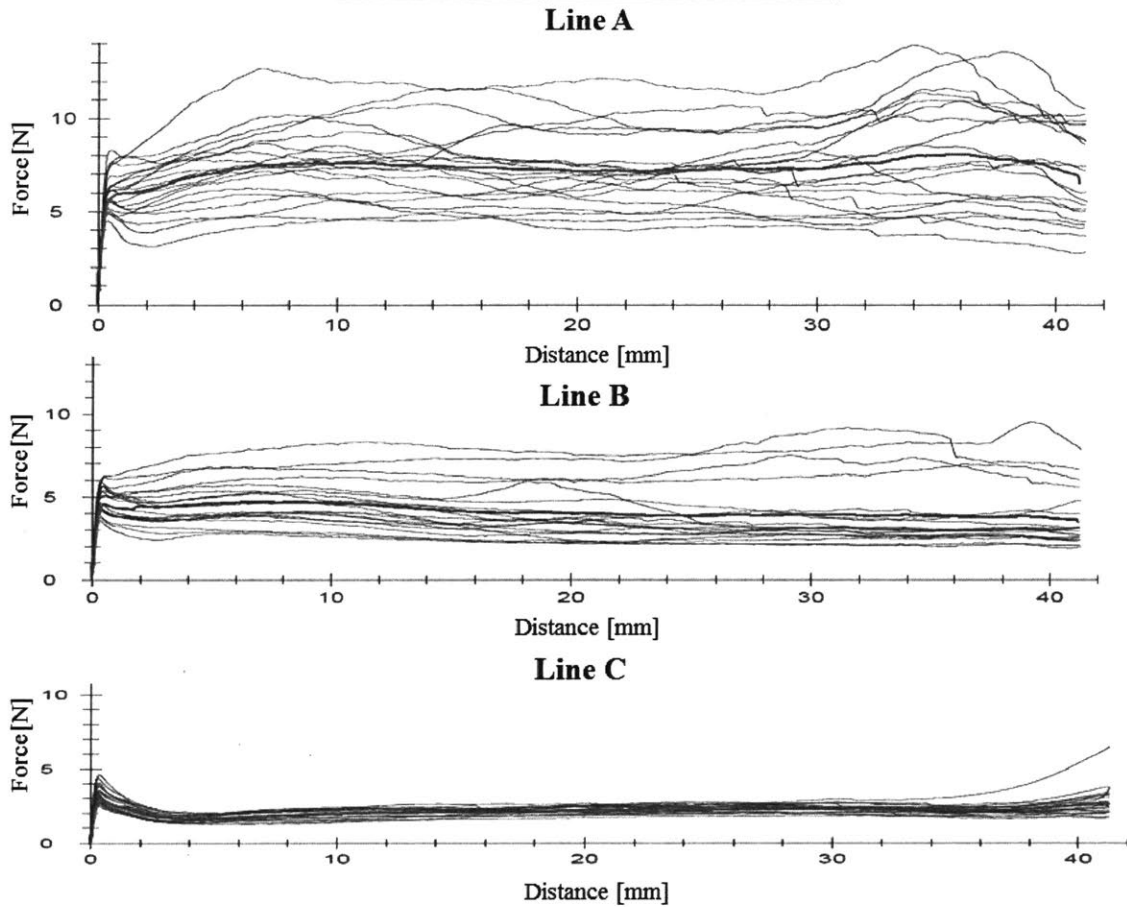

Figure 5-9: Friction Force Profile for Cartridges

The key metrics used to evaluate and compare friction forces are average gliding force, break loose force, maximum gliding force and absolute maximum force. Each of these is calculated for a single cartridge measured using the Zwick®. Averaging these metrics provides the data for comparison. The absolute max reported is the largest force observed for a single cartridge among all those sampled; it is not an average. In addition the variation of these metrics within a large enough data set can be used to objectively measure differences between line variability. The two metrics used to compare variation were average gliding force and max gliding force. The differences in magnitude are summarized in Figure 5-10 and variation is summarized in Figure 5-11.

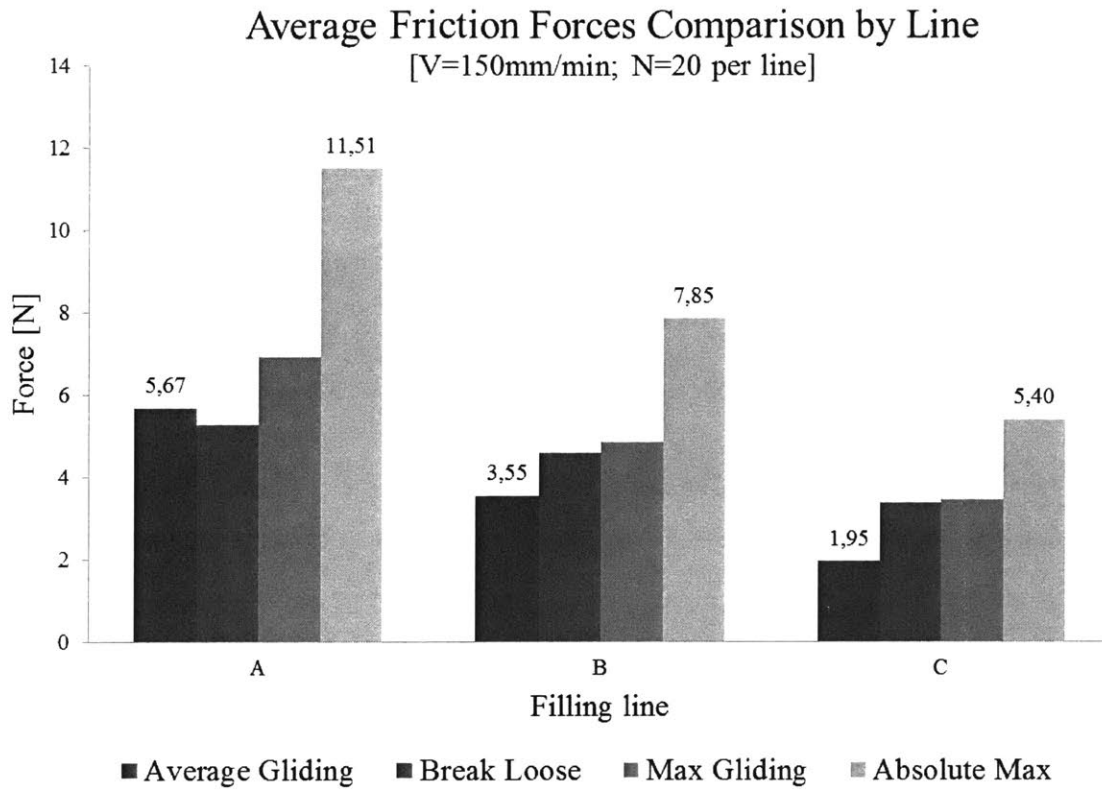

Figure 5-10: Line Characterization - Average Friction Forces

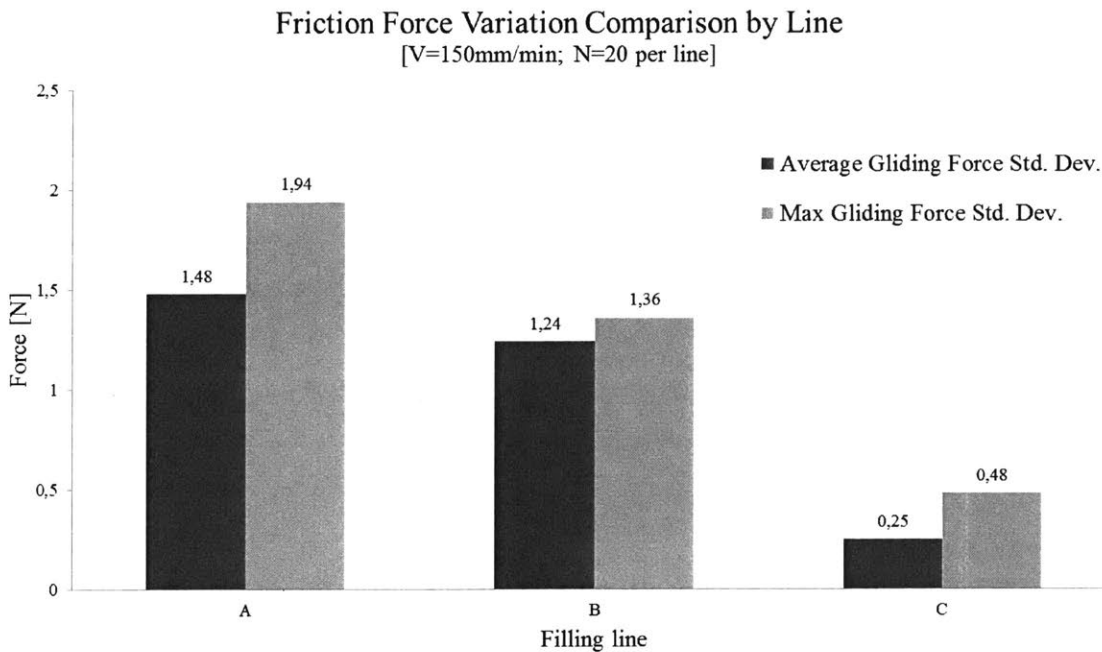

Figure 5-11: Line Characterization - Variation of Gliding Forces

The silicone profile and subsequent friction forces are correlated in these samples. This relationship observed here is a core insight that will be discussed in detail in Chapter 6. The three siliconization methods used at SFI produce cartridges with different siliconization profiles and different friction forces. All lines produce cartridges that meet quality standards necessary for effective performance in the current devices; however, new devices require tighter control of friction forces for optimal performance. Knowing the current state of the siliconization processes sets the stage for further investigation into key process settings effecting the siliconization profile and ultimately optimization.

5.3 Characterization in the Context of Device Performance

5.3.1 Introduction to Pen Systems

The metrics evaluated to characterize the siliconization methods are designed to provide insight into cartridge performance in both existing and future injection pens.

Understanding of the pen mechanics, dynamics and performance criteria is critical to identifying risks of insufficient performance. For the majority of current devices, like the SoloStar®, the injection is manually driven by the user's hand. The control systems embedded in human motions are very precise and able to adapt under a wide range of environments. Consider a patient using the SoloStar®. If the patient is seeking constant velocity injection, they simply adjust the pressure applied to the injection button from their thumb as resistance within the cartridge and needle change. The human body does this naturally and very effectively. Trends in the industry, however, are moving away from manually driven devices and towards auto injectors. Studies have shown that patients prefer an auto injector because they do not like the feeling of injecting themselves with a manual process. With spring assisted injection as the future of injection devices, these devices require better control of forces opposing injection.

For a spring assisted pen the torsion spring is loaded when the patient dials a specific dose. With the click of the injection button the torsion spring begins to relax, forcing the lead screw and bearing forward and exerting its force on the rubber stopper and therefore driving insulin through the hypodermic needle and into the patient. The torsion spring, bound by the natural properties of springs, has a force profile in which the force decreases proportionally with displacement distance [32]. This means that the largest risk for stalling, where the friction force is greater than the spring force, is at the end of dose when the spring is more relaxed. Similarly the largest risk for too fast an injection is at the beginning of the dose when spring force is highest. While too fast an injection can cause slight discomfort to the patient and is a concern, the alternative where a stopper stalls is of greater concern because it could leave a patient without their proper dosage of Insulin. To evaluate cartridges with this in mind, forces must be compared against the lowest force produced by the spring, which occurs at the end of the dose. The largest force encountered during gliding, as measured by max gliding force for a given cartridge or the absolute max gliding force for a sample set of cartridges, is the key metric used to evaluate friction forces against the spring's operating force.

The trend of silicone layer height of Line C (Figure 5-7) shows a thinner layer of silicone at the top of the cartridge. This location at the top of the cartridge is also a position where the spring will be partially relaxed and therefore exert less force. This suggests that perhaps more silicone should be present at the top of the cartridge where spring force is lower. On the other hand, experiments have demonstrated that during injection silicone is moved forward through the cartridge along with the rubber stopper by a 'plowing' effect [33]. This 'plowing' effect may be enough to compensate for reduced spring force at the top of the cartridge.

In the context of device design, in order to control injection velocities as much as possible, the **variation** of gliding forces from one cartridge to the next needs to be reduced, not necessarily the magnitude of gliding forces themselves. As long as gliding forces are consistent within a cartridge and from cartridge to cartridge, pen devices, specifically spring profiles, can be designed for accurate performance. The most applicable metrics used to evaluate this variation are average gliding force variation and max gliding force variation. These metrics directly influences the variation in injection times and therefore control, which can limit design advances.

5.3.2 Importance of Filling Line Flexibility

It is clear that significant differences exist between cartridges produced on line A, B and C. One approach to circumvent what might be a problem is to specify which cartridges (from which line) can be used for which devices. For example the variable and higher friction forces characteristic of cartridges from line A may be restricted for use with manual pens, while cartridges from line C, which show lower friction forces and better control, may be used for Sanofi's auto-injection devices. While this requires additional logistical considerations, this may be a viable plan while Sanofi's device portfolio is relatively homogenous and if forecasting is accurate. However, this reality is changing quickly and as Sanofi innovates and brings new devices to market, the ability to manufacture with flexibility and speed will become increasingly important.

This flexibility needs to include the core components of the device, including the Insulin containing cartridge. As demand surges for a particular device, Sanofi cannot be limited by its ability to produce cartridges on a single filling line when it has the mechanical capacity of several filling lines. The production of cartridges with consistent performance regardless of which filling line it is produced from is an important strategic capability that Sanofi has to take advantage of.

Additionally this improved capability allows for more streamlined design and development process for new devices. New devices can be developed using a set of consistent cartridge requirements which are well defined and accurately reflect performance. New devices under evaluation will be compatible with all cartridges produced by SFI, eliminating redundant required evaluation testing.

To achieve constant performance across fillings line, defining a target siliconization profile is critical. This profile can be defined in terms of device performance and correlated to other metrics that can be measured and used to predict performance. The following chapter is dedicated to that task.

6 Friction Correlations and Recommended Silicone Profile

6.1 Silicone Amount and Friction Forces

The differences observed between filling lines during characterization and the goal to reduce variation requires an understanding of how silicone profiles impact friction forces and ultimately device performance. Optimization efforts to produce cartridges with consistent friction forces can begin only when the optimization parameters are specified. This chapter develops the context and recommendations for defining a silicone profile that will result in a cartridge with desirable friction performance.

It is expected that there is a relationship between amount of silicone deposited on the inner surface of a cartridge and the subsequent friction forces of that cartridge. General lubrication theory suggests that up to a point, the more silicone present on the cartridge surface the lower the friction forces will be. The nature of this relationship for this specific system is explored by siliconizing cartridges with different amounts of silicone and measuring their friction forces.

3.0ml cartridges were siliconized using a test pressure-time spray siliconization system produced and operated by Bosch®, one of Sanofi's manufacturing equipment providers. The system used is nearly identical to that used in production on Line B. Process parameters including baking temperature and time were set at specified set points recommended by Bosch and kept constant during siliconization except for two parameters. The concentration of emulsion used in the process was varied between 0.67% and 17.5% to produce cartridges with varying amounts of silicone deposited on the inner surface. The atomizing pressure was set at either 0.8bar, 1.2bar or 1.8bar during siliconization with a separate goal to investigate the impact of pressure on silicone profile and gliding forces.

Friction forces are evaluated with similar methods described in Chapter 4, but using an injection velocity of 100mm/min. These forces were evaluated by one of Sanofi's manufacturing equipment providers, who use 100mm/min as their standard protocol. As in the case of the filling line characterization, average gliding force and maximum gliding force are the key parameters being assessed. The average of forces are plotted in Figure 6-1 and the data is fit to a power curve, which shows a good fit.

Friction Force vs. Average Siliconization Amount
[3.0ml cartridge; V=100mm/min; N=135]

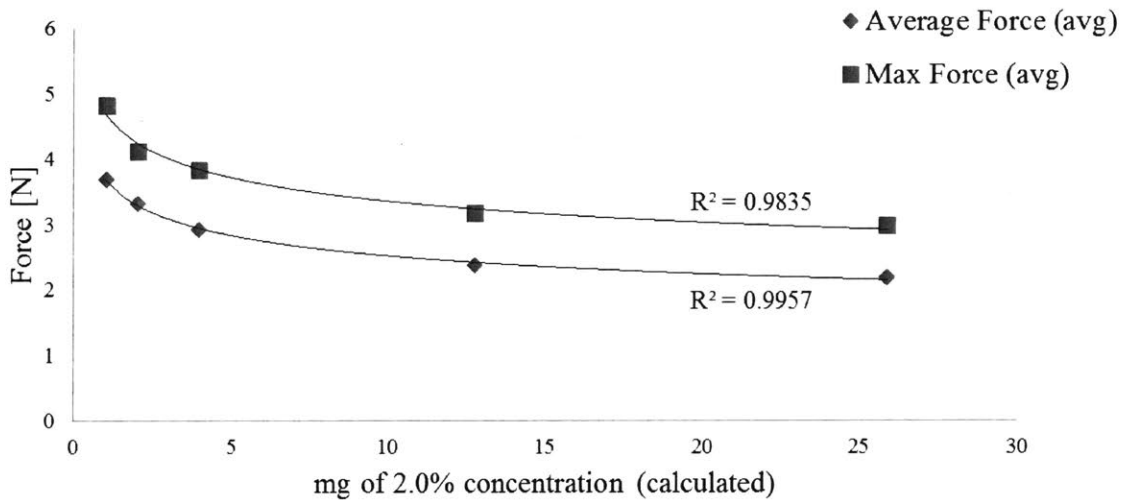

Figure 6-1: Friction Force Correlation with Silicone Amount, Averages

The data presented here supports previous work done by Schacherl, examining the relationship between silicone amount and friction coefficient on flat glass using a linear tribometer [17]. Results suggest an exponential relationship between friction and siliconization amount. At very low levels of silicone, the friction coefficient increases significantly, however, once a minimum is reached, the further increase in silicone amount does not lead to a significant decrease in friction.

This presentation of data, however, does not tell the full story. The data presented in Figure 6-1 are averages across several samples. While averages are valuable in understanding trends and general behavior, the relationships discovered must hold true the majority of the time for individual cartridges. Presented in Figure 6-2 and Figure 6-3 are the friction forces for individual cartridges plotted against their silicone amount. The variation in forces demonstrated by these plots calls into question the validity of the exponential relationship described by the averages alone. What becomes even more apparent here is that within a constant silicone amount, friction forces can still vary significantly.

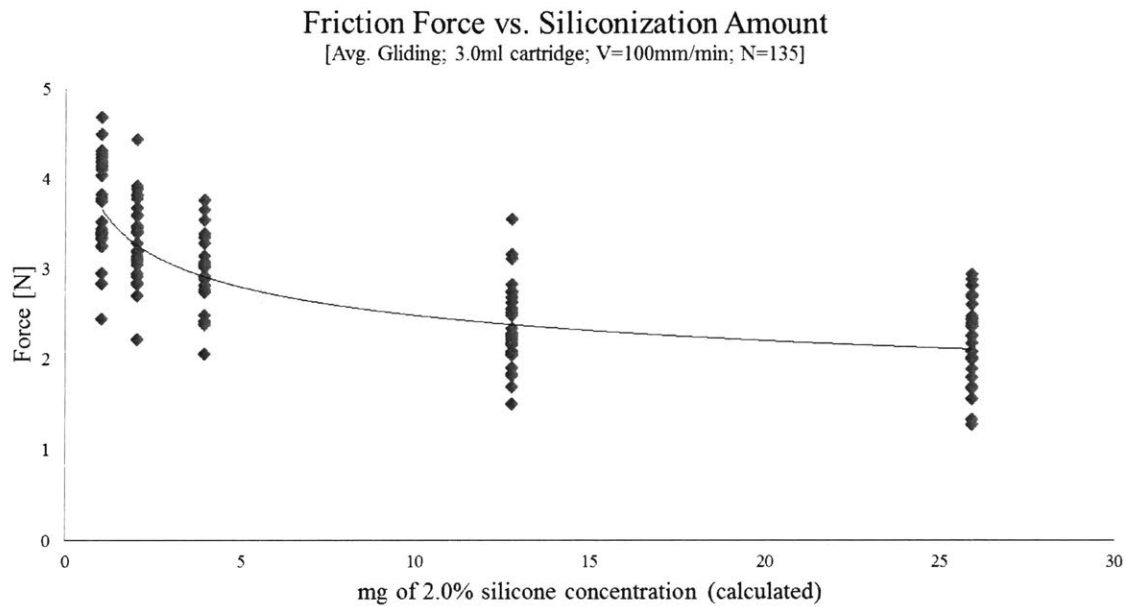

Figure 6-2: Average Gliding Force Correlation with Silicone Amount

Friction Force vs. Siliconization Amount [Max Gliding; 3.0ml cartridge; V=100mm/min; N=135]

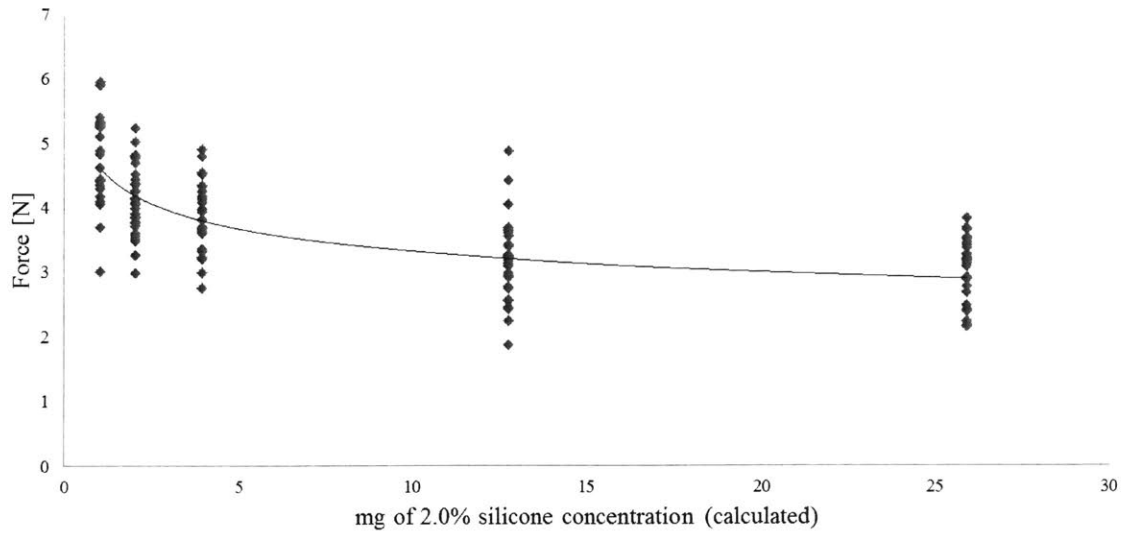

Figure 6-3: Maximum Gliding Force Correlation with Silicone Amount

The type of silicone profile produced by this Bosch system must also be taken into consideration. The relationships developed here may only be valid for this specific siliconization profile. The silicone profiles produced using Bosch recommended settings have higher amounts of silicone concentrated at the bottom end of the cartridge and lower thickness at the top or needle end of the cartridge. A characteristic silicone profile of cartridge siliconized with these settings can be visualized in Figure 6-4.

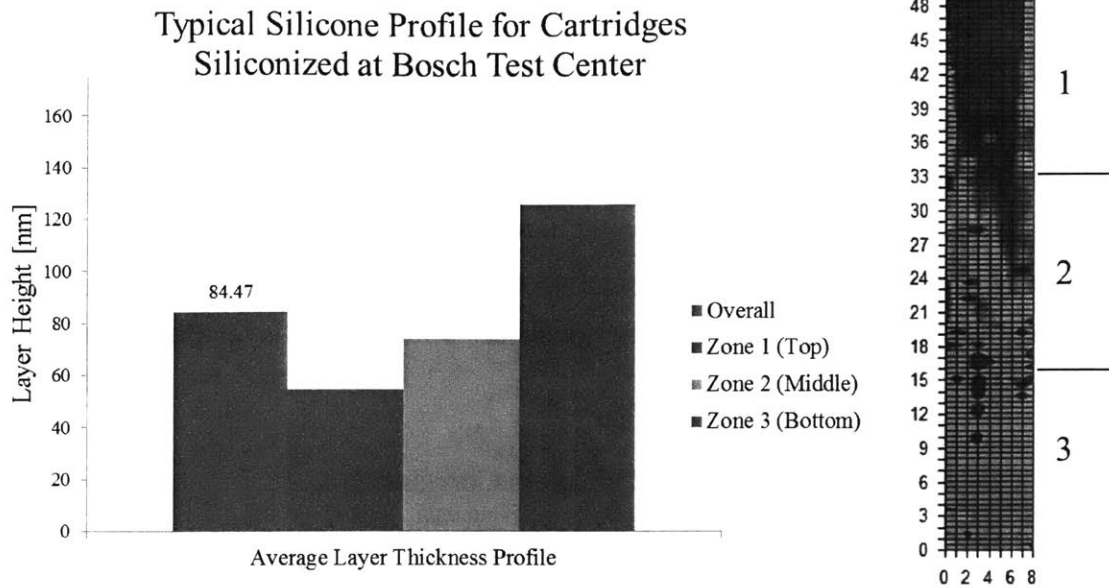

Figure 6-4: Typical Silicone Profile for Cartridge Siliconized at Bosch

This data describes a relationship between friction forces and silicone amount for a specific siliconization profile and shows a large degree of variability and uncertainty. While this still informs a general relationship, a different approach is now taken to describe the relationship between silicone amount and friction forces and inform a recommendation using empirical data and a more practical approach.

6.2 Defining a Good Siliconization Profile

6.2.1 How to Define a Good Siliconization Profile

An empirical approach is used to develop criteria for a good siliconization profile by correlating measurements to parameters that are used to evaluate performance, in this case friction forces. Parameters are correlated to one another directly and used to build a data set. This data set is then used to inform and define recommendations.

6.2.2 Silicone Layer Thickness Recommendation

The rap.ID layer explorer is one of the newly available instruments that can be used to quantify a baked-in silicone profile on the inner surface of a cartridge and its use in filling line characterization was demonstrated in Chapter 5. The same core metrics, average layer thickness and percent of dry spots are used here to develop friction correlations. Taking cartridges produced during normal production runs on five filling lines, including lines A, B and C, the direct correlation between friction forces and average layer thickness are plotted in Figure 6-5.

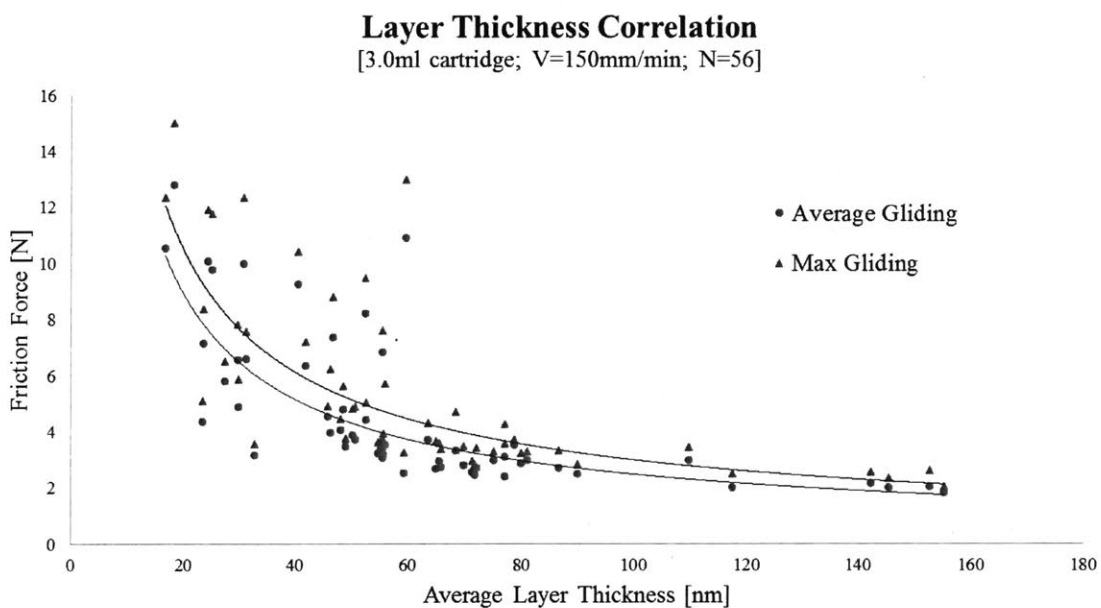

Figure 6-5: Silicone Layer Thickness Correlation to Friction Forces

Once again this exponential relationship of silicone amount and friction force presents itself in the data, reinforcing evidence of this relationship. What is also clear from this data is that at lower average thickness layers, friction force becomes increasingly more unpredictable and the variation of friction forces increases dramatically. Using this data the recommendation is for cartridges to achieve an average silicone thickness layer greater than 60nm.

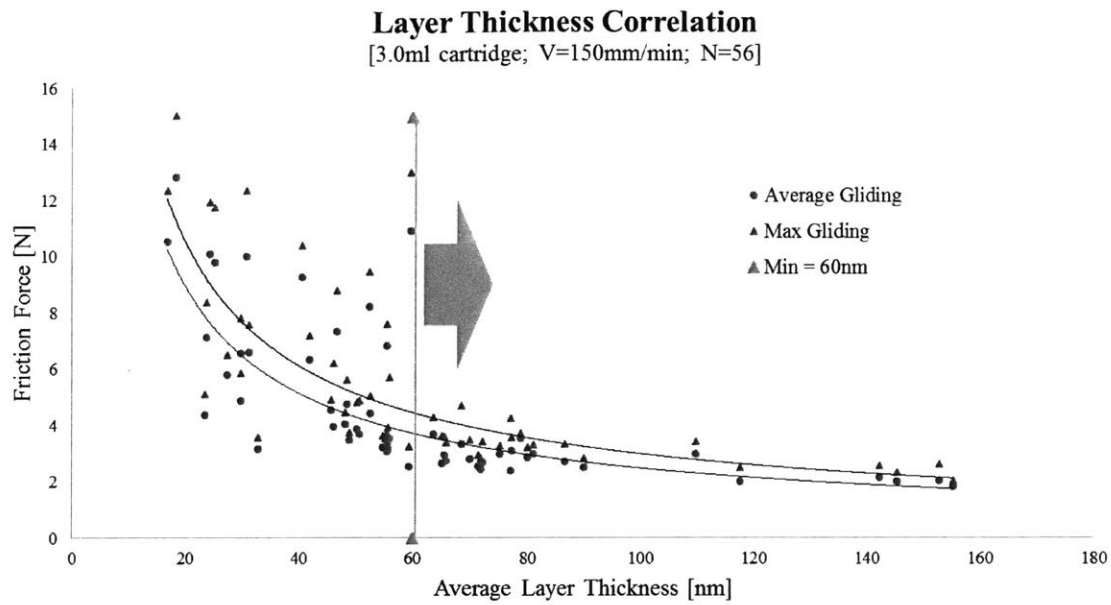

Figure 6-6: Silicone Layer Thickness Recommendation

6.2.3 Percent Dry Spot Recommendation

There are a couple of potential shortcomings in the recommendation based on average silicone thickness if that recommendation is taken in isolation. For example, a situation can be imagined where a large amount of silicone is deposited in a concentrated area of the cartridge and the rest of the cartridge is mostly uncoated. This could result in an average silicone thickness layer greater than 60nm but still present problems. In an effort to protect against that situation another recommendation is introduced in parallel with an average thickness layer greater than 60nm. This recommendation uses the metric defined as dry spots and Figure 6-7 shows the correlation developed using the same data set above.

Dry Spots Correlation

[3.0ml cartridge; V=150mm/min; N=56]

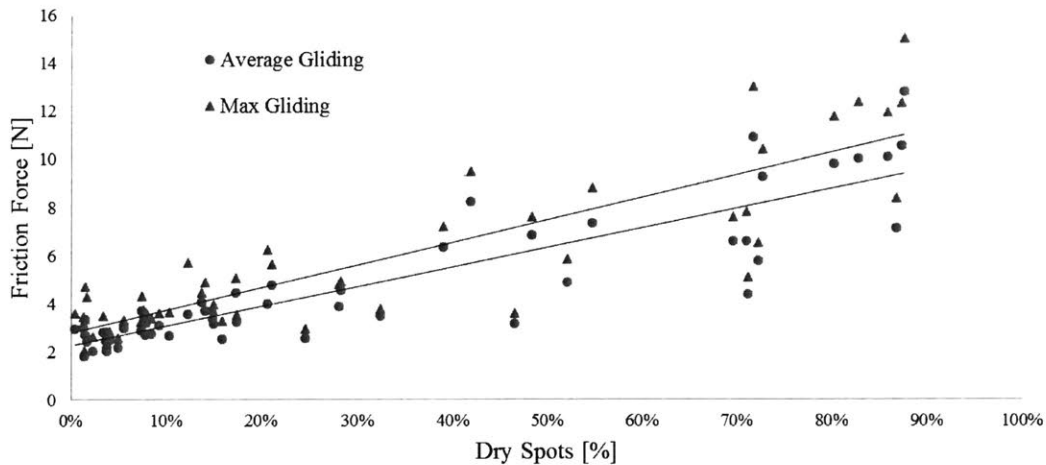

Figure 6-7: Dry Spot Correlation to Friction Forces

The relationship between dry spots and friction force appears to be linear in nature. This suggests that forces do not increase as dramatically as a function of dry spots. Because this data set is the same data set used to evaluate silicone layer thickness it is not surprising that a similar cluster with less variation is seen in the bottom left of Figure 6-7. This data suggests that adopting a recommendation that cartridges maintain a dry spot percent less than 35% will be sufficient to eliminate high variation; however, upon expanding this data set by running 50 more samples, there were cartridges with dry spots measured between 20-35% that showed high friction forces (Figure 6-8). Using this additional data the recommendation for cartridges is to maintain a dry spot percent less than 20%.

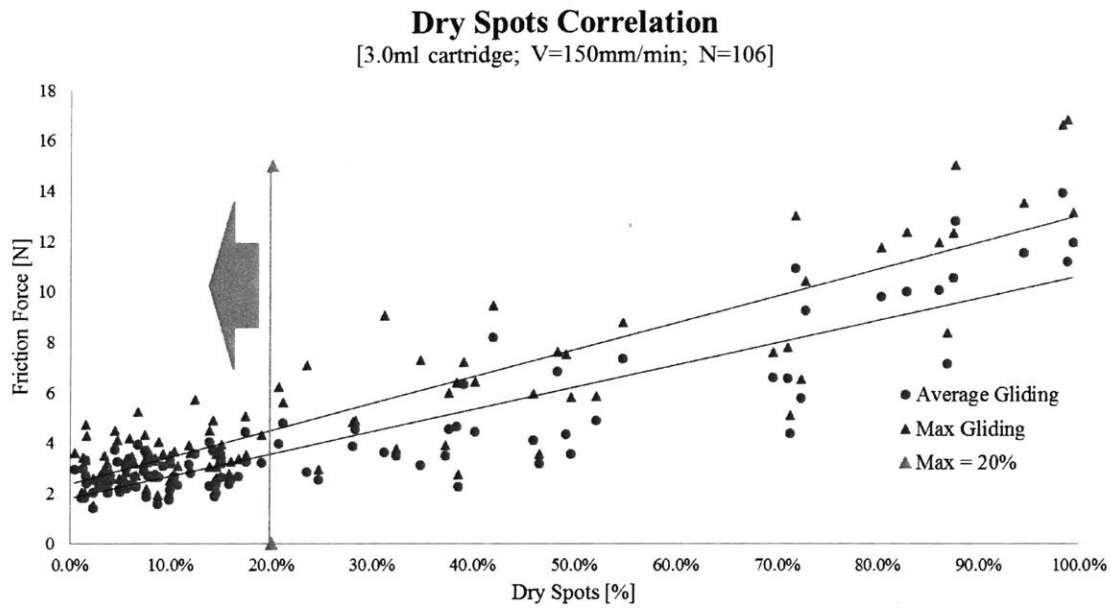

Figure 6-8: Dry Spot Recommendation (expanded data set)

6.2.4 Silicon Profile Recommendations and Impact

Looking at both parameters together provides a more complete picture of how these recommendations will improve and reduce variability of friction force. Figure 6-9 shows the relationship of average layer height and percent of dry spots impact on friction force. The data points circled within the oval are data points that fall within the recommendation guidelines.

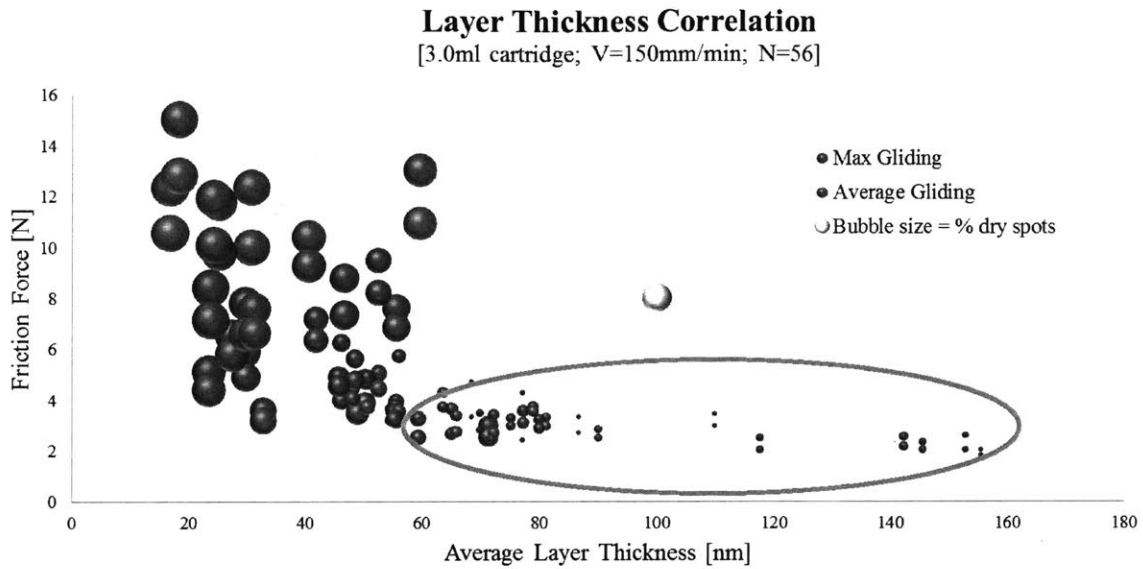

Figure 6-9: Layer Thickness and Dry Spot Recommendation

As discussed before, this data set was expanded significantly by measuring an additional 50 cartridges siliconized using lab-scale siliconization equipment similar to the system of Line C but with varied equipment settings. Figure 6-10 shows this expanded data set follows the same trend originally observed.

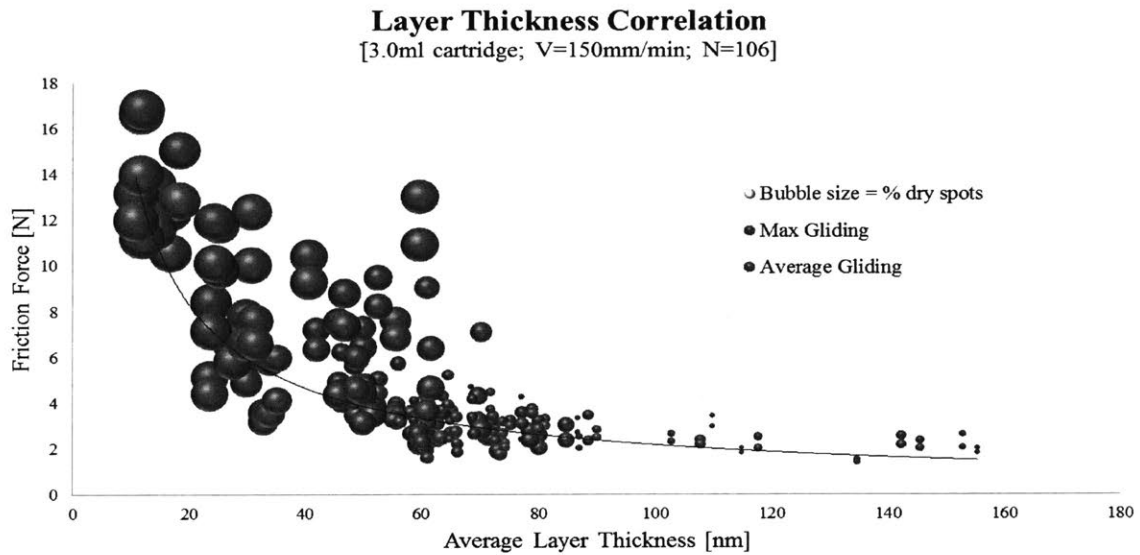

Figure 6-10: Layer Thickness and Dry Spot Correlations Expanded Data Set

Additional plots of this data are shown in Figure 6-11 and Figure 6-12 where the data points fitting the recommended profile are separately colored (Figure 6-11) and where data points indicate which filling line the sample cartridge evaluated was siliconized on (Figure 6-12).

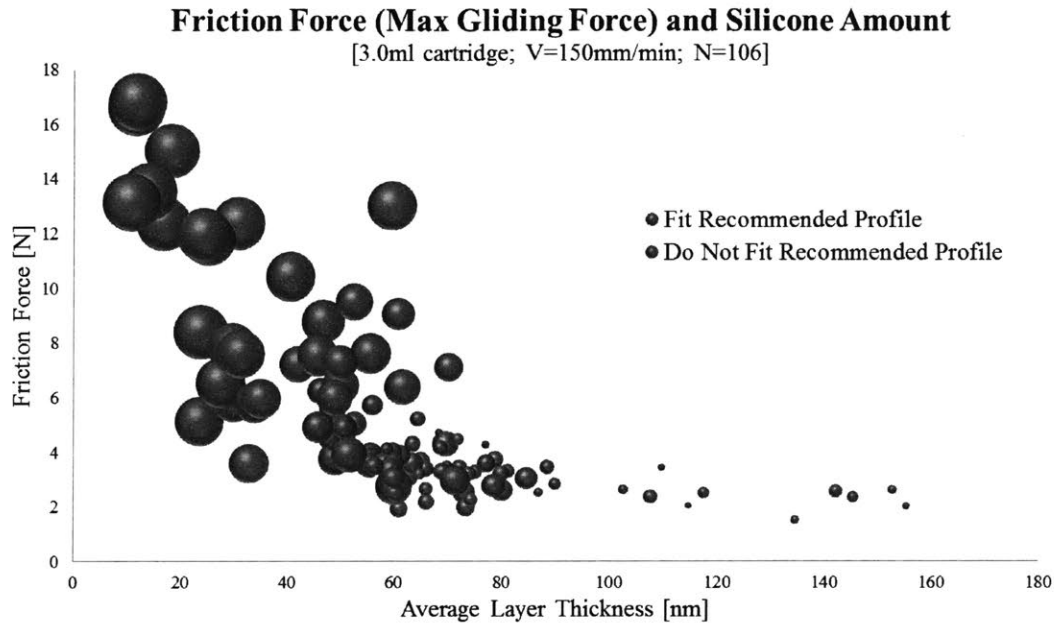

Figure 6-11: Data Fit Recommendation

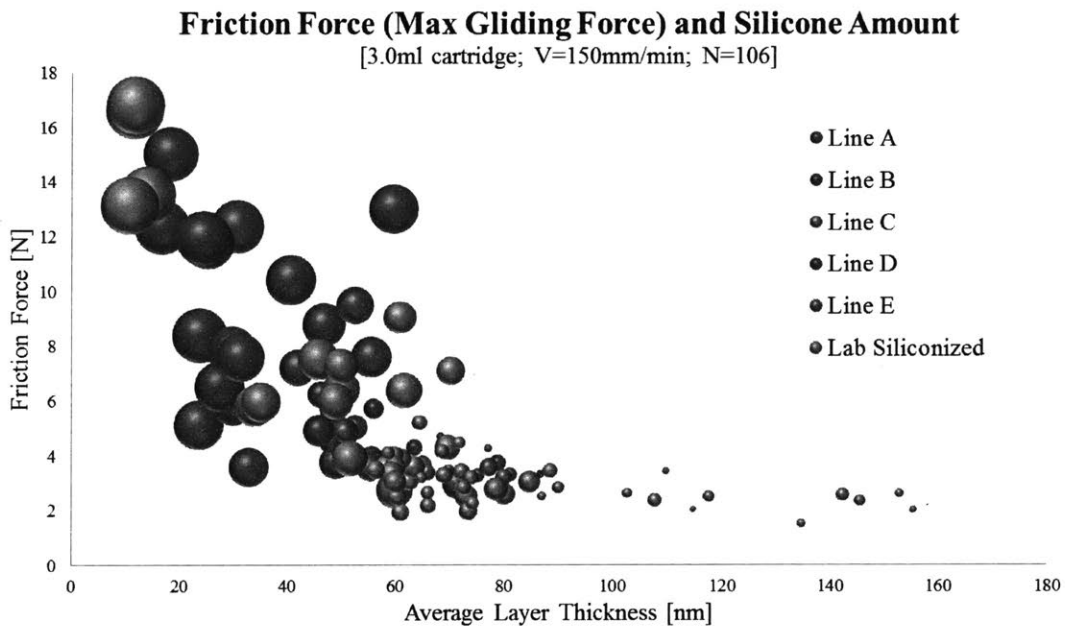

Figure 6-12: Data by Filling Line

A key takeaway from Figure 6-12 is the variability between different siliconization methods (lines) but also within a given production line. The positive take-away is that all siliconization methods (Lines A, B, C) have the ability to produce cartridges that fit the recommended profile. This key point shows the future opportunity in siliconization equipment optimization to achieve the recommended profile is possible. Achieving this recommended profile, as compared to current state, provides a significant improvement in friction force variation. Table 6-1 shows the improvement potential in reducing variation, specifically an 18-24 times reduction in variance depending which data set is used. Variance is a statistical measure of variation or variability defined as the sum of squares of values deviating from the mean of a data set as described in Equation 6-1:

$$\sigma^2 = \frac{\sum(X - \mu)^2}{N} \quad (6-1)$$

Where σ^2 is the variance, X is each sample value for max friction force, μ the mean max friction force from the data set of N samples. In this case N is either 56 or 106 as described in Table 6-1.

Table 6-1: Silicone Profile Recommendation Impact on Variability

Maximum Gliding Force Variation				
	<i>Original Data Set</i>		<i>Expanded Data Set</i>	
Friction Force Metrics	Cartridges that Fit Recommended Criteria	Total Data Set	Cartridges that Fit Recommended Criteria	Total Data Set
Sample Count	22 (39% of samples)	56	49 (46% of samples)	106
Minimum Force (N)	2.03	2.03	1.53	1.53
Maximum Force (N)	4.71	15.03	5.22	16.82
Standard Deviation (N)	0.64	3.15	0.78	3.33
Variance	0.41	9.89	0.61	11.11
Reduction in Variance Original Data Set: 24x Expanded Data Set: 18x				

It has been clearly demonstrated that different siliconization profiles have an impact on friction forces. The results used to set the recommendation are driven by real samples produced on the filling lines during normal operation. There is an opportunity to further add to and refine the recommendations given here by gathering more samples, analyzing their silicone profile and parameters using the rap.ID and evaluating friction forces using the Zwick. Adding additional samples will improve the statistical significance of these results and uncover gaps that might exist.

Using this recommendation for the continued goal to reduce variation in friction forces by siliconization optimization, efforts are now turned to improving the silicone profile to achieve the recommended silicone profile attributes. In particular Atmospheric Pressure Plasma treatment is explored as a pretreatment for cartridges in an effort to improve silicone uniformity (i.e. reduce dry spots).

7 Atmospheric Pressure Plasma Treatment

7.1 Opportunity for APP Treatment in Siliconization Process

As described in Section 3.4, atmospheric pressure plasma (APP) treatment increases the surface energy and wettability of a substrate by removing contaminants and ‘super cleaning’ the surface. It does this under atmospheric conditions allowing feasible integration of an APP system into a manufacturing line. This treatment step, if integrated into the filling lines, would have an associated cost; however, these costs could be offset by reduction in other process steps, specifically the water bath ultrasonic wash. A cost analysis would need to be done to determine the efficacy of such a project. Prior to this analysis it is critical to understand what effect, if any, APP treatment has on siliconization profile and subsequent gliding forces. This chapter describes testing to accept or reject the hypothesis that APP treating the inner surface of glass will improve silicone uniformity and distribution, specifically by reducing dry spots.

7.2 APP Testing and Evaluation Methodology

APP treatment requires specialized equipment for treatment. In order to treat glass samples, a partnership was established between MIT, Sanofi and SEP Inc. SEP is a research and application lab in South Korea run by Dr. Sang-Ro Lee. SEP specializes mostly in electronic applications with over 20 years of experience with plasma treatment. Glass samples were sent to SEP for APP treatment and analyzed in SEP’s lab and sent back to Sanofi in Frankfurt to be siliconized and tested. The core analysis carried out to test the hypothesis were contact angle measurements, visual wettability effects, surface roughness measurements and finally a low-level DOE to compare friction force impact with different cleaning methods including APP.

These analysis methods give information about the surface energy and wettability of glass; however, some of the traditional methods of analysis are challenging to perform on the inner surface of a cartridge. Therefore, the contact angle and surface roughness measurements were done on flat plate glass which closely matches the properties of the cartridge glass. This glass was APP treated and used for contact angle and surface roughness measurements. Visual effect of wettability and friction force measurements were done using glass cartridges to more closely simulate real application. The DOE study was done with glass cartridges as well so that friction forces could be evaluated using the same methods previously discussed.

The three techniques provide a comparison between untreated and APP treated glass surfaces. The results of these analyses are interrelated because of the nature of the investigation. A lower contact angle is descriptive of higher surface energy which leads to a higher degree of wettability. Furthermore it has been demonstrated both theoretically and through experiments that in general, an increase in surface roughness leads to an increase in surface energy [20].

Finally an important factor of this experimentation is the time between APP treatment and analysis. This time factor, the amount of time between treatment and siliconization or analysis, is described for each analysis result and discussed in detail in Section 7.6.

7.3 APP Treatment at SEP

Section 3.4 describes how APP treatment works. The equipment used for APP treatment is typically used for flat substrates; however, it was adapted with minimal adjustments to accommodate cartridges. The plasma was applied at both ends of the cartridges sequentially for 60 seconds at each end. The ideal treatment takes place with more direct contact and can achieve the same effect in significantly less exposure time (~1-2 seconds). The parameters used for treatment are described in Table 7-1.

Table 7-1: APP Experimental Conditions

Plasma			Cathode (Area: 26,000mm ²)		Gas	
Voltage	Power	Frequency	Length(mm)	Width(mm)	N2 (slm)	Dry Air(slm)
12 kV	4.0 kW	30 kHz	650	40	800	1.6
Plasma 'on' time:		60sec	Gas applied to single cartridge:		2.2	4.4

*Parameters set and treatment performed by SEP [27]

Figure 7-1 shows a graphic describing this process for APP treating the sample cartridges.

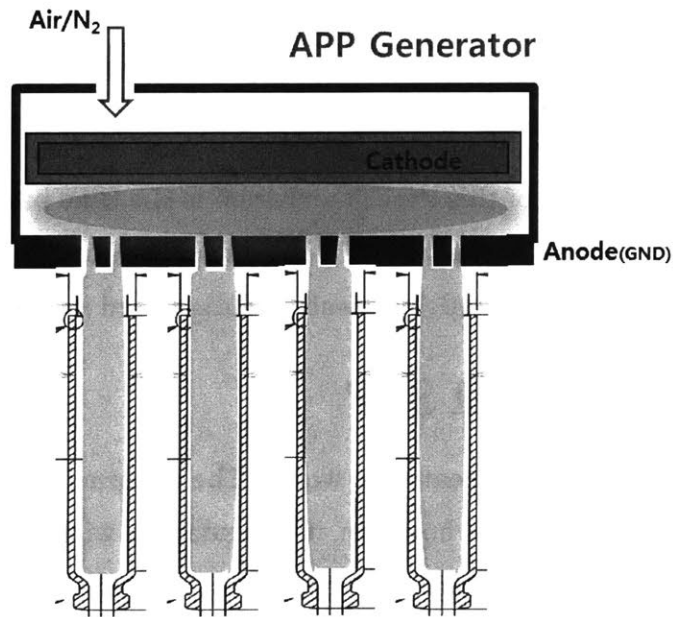

Figure 7-1: APP Generation for Cartridges [27]

Following treatment, cartridges were vacuum packed in an effort to preserve the treatment effect and prevent re-contamination of the glass inner surface.

7.4 Glass Surface Effects

7.4.1 Contact Angle Measurements

Contact angle measurements are used to describe the surface energy of a substrate. The larger the contact angle, the lower the surface energy. Surface energy can be thought of as the energy required overcoming surface tension of a spherical drop of water resting on a substrate. As the surface energy increases, the water droplet is 'pulled' towards the surface due to chemical and physical interactions. Contact angles are measured as a proxy for surface energy and use the principle of water droplets and surface tension. The impact of APP treatment on contact angle and by extension surface energy is very significant and can be seen in the results from the analysis presented in Figure 7-2.

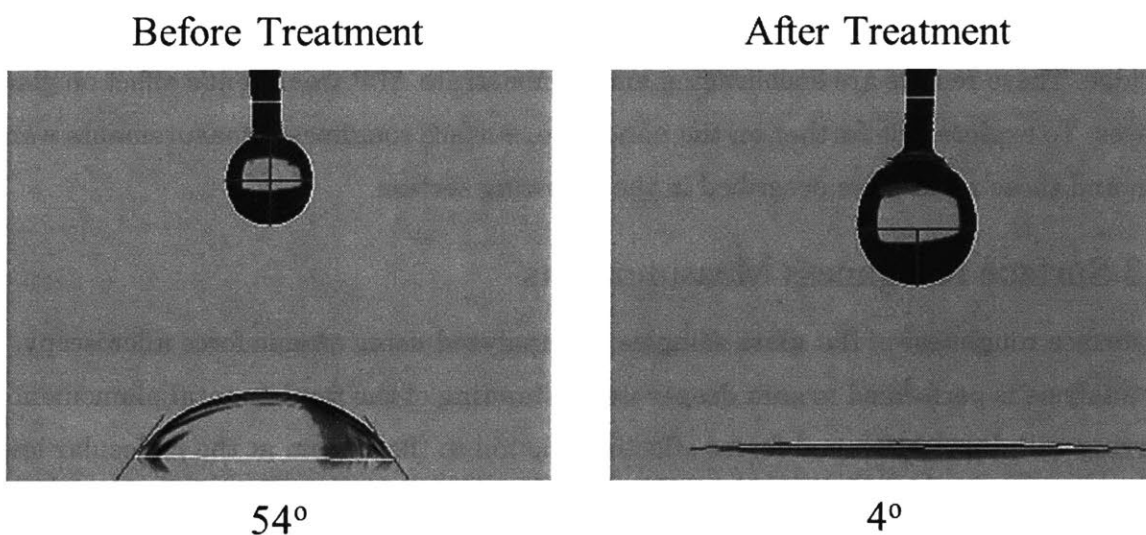

Figure 7-2: Contact Angle Measurement APP Study

This analysis was performed by SEP in their lab and the measurements were performed on flat glass samples sent to SEP from Sanofi. The measurements of the sample after treatment were taken within one minute from when the glass cartridge was treated with APP. The effect is dramatic, showing the clear influence of APP treatment on glass surface energy and wettability. These results support the hypothesis that APP treating glass improves the wettability.

7.4.2 Visual Wettability Measurements

Extending this analysis to cartridges Figure 7-3 shows qualitatively how a solution spreads on an untreated cartridge versus an APP treated cartridge.

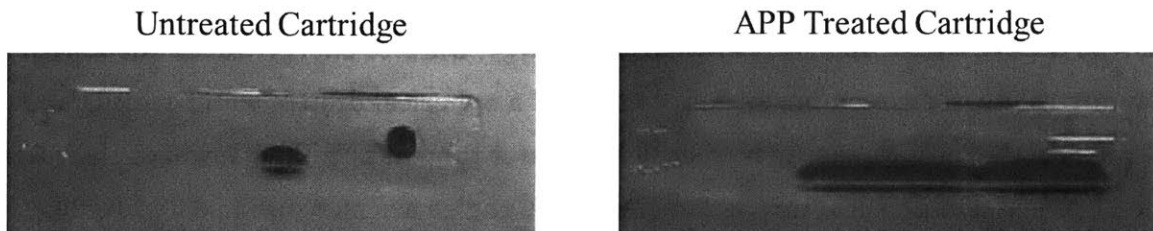

Figure 7-3: Visual Wettability Test APP Study

Again, the effect is quite dramatic and supports the hypothesis. This analysis was also done by SEP and the solution was applied inside the cartridge using a pipet needle. The solution was applied within minutes after APP treatment had taken place for the APP treated cartridge. These results are encouraging and demonstrate APP treatment's effect on glass surfaces. To explore this further on the nanoscale, surface roughness measurements were taken and those results are described in the following section.

7.4.3 Surface Roughness Measurements

The surface roughness of flat glass samples are analyzed using atomic force microscopy. This analysis is performed to gain deeper understanding of the fundamental phenomenon occurring with lubrication and forces effecting friction in the system at the molecular level. This analysis is discussed in more detail in Appendix G; however, comparing surface roughness of untreated and APP treated glass samples provides further data to describe the effects of APP treatment on glass surfaces. Figure 7-4 and Figure 7-5 show these comparisons in two-dimension and three-dimension formats respectively.

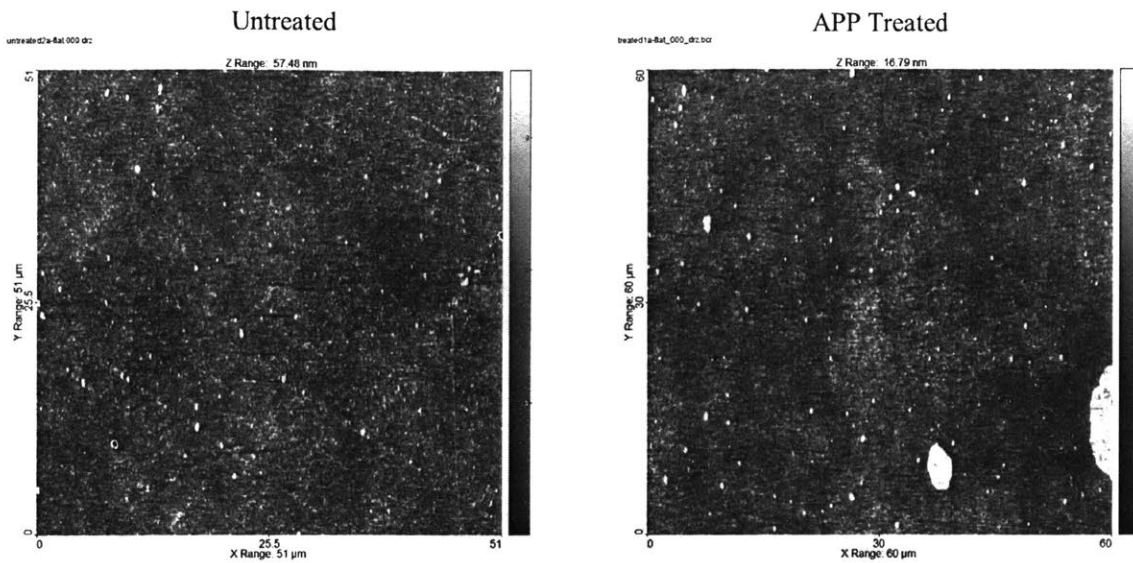

Figure 7-4: Glass Surface Roughness Color Scaling 2D

Figure 7-4 shows a comparison of height values contributing to roughness core values by color scaling. The data displayed ranges from 0 nm to 3.5nm, which is the upper threshold. Higher elevations are lighter in color with white being the highest points measured. The APP treated glass was treated about four weeks prior to this analysis and kept in vacuum sealed plastic up until the time of analysis. The white regions on the APP treated cartridge in the lower right hand corner are likely dust that accumulated on the sample during transfer. Judging these images qualitatively, there appear to be no discernable differences between untreated and APP treated glass surface roughness. Figure 7-5, a representation of surface topography in three dimensions, similarly shows very little difference between untreated and APP treated glass.

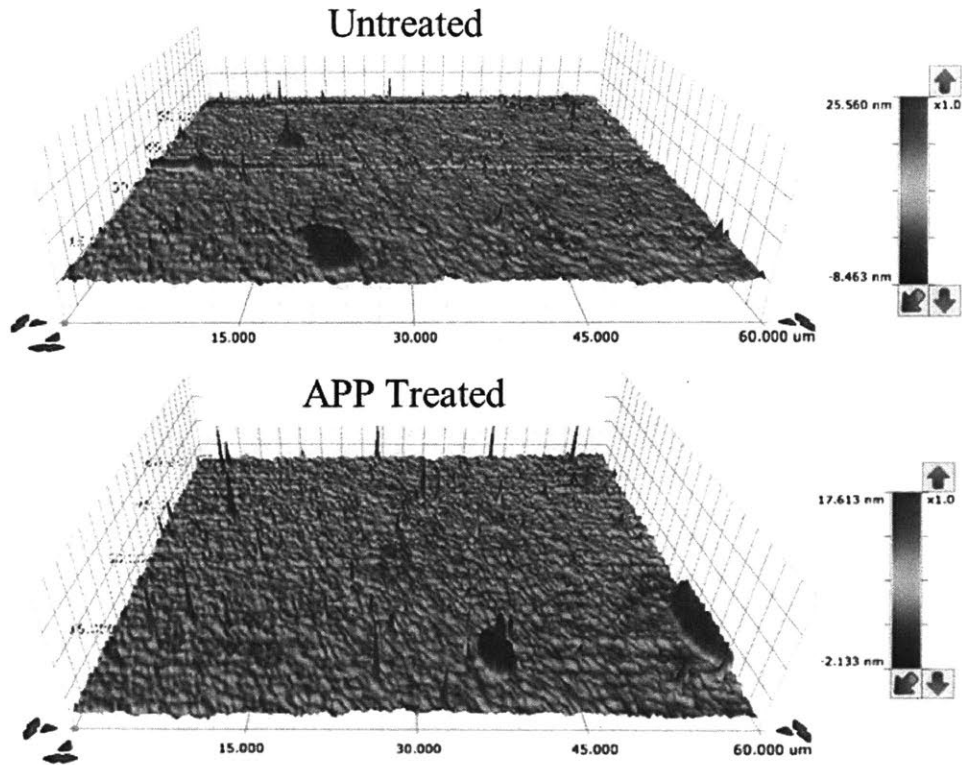

Figure 7-5: Glass Surface Roughness 3D

The data used to produce these images is also used to calculate roughness values for the different samples. R_a is a value used to describe the surface roughness of a material. R_a is a measurement of a surface's peaks and valleys. R_a is defined by ASME standards as the arithmetic average of the absolute values of the profile height deviation from the mean line evaluated over a length or area [34]. Equation 7-1 below describes this calculation where n is the number of data points (equally spaced along a line or several lines) and y_i is the height profile or difference from the mean height.

$$R_a = \frac{1}{n} \sum_0^n |y_i| dx \quad (7-1)$$

Shown below in Figure 7-6 are the roughness values for six untreated and six APP treated flat plate glass samples. The data suggests slightly higher surface roughness on the APP treated samples. On average the surface roughness of APP treated glass is 10% higher than untreated glass. While this difference is small, it does indicate that APP treatment has the effect of slightly increasing surface roughness, which is known to increase surface energy and wettability.

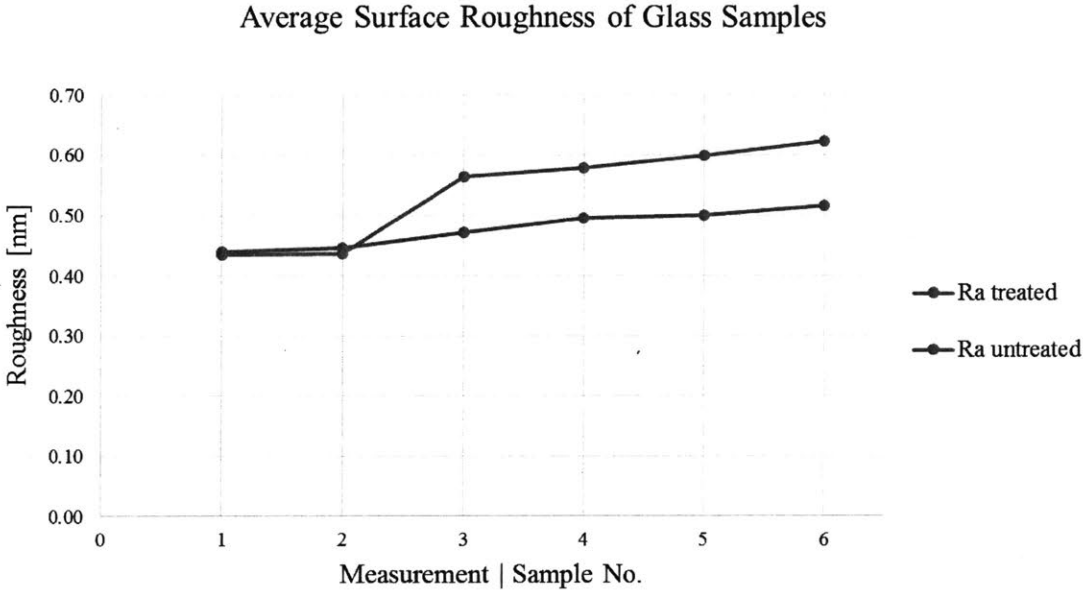

Figure 7-6: Surface Roughness of Glass Samples

The data shown here indicates that APP treatment impacts the glass surface by lowering contact angle, increasing surface energy, increasing wettability and slightly increasing surface roughness. The effects observed by visual comparison, which were analyzed four weeks after treatment, show little difference between untreated and treated samples. It is clear that under certain circumstances APP treatment has the desired effect on glass; however, to fully test the hypothesis, the treated glass must be siliconized and evaluated using friction force measurements.

7.5 Pre-Siliconization Washing Effects

7.5.1 Experiment Set-up

This study examines the impact APP treatment on glass cartridges has on silicone profile and subsequent friction forces for cartridges. To test this, the scope of the study was expanded to explore the effect different washing and pre-treatment methods have on shaping a cartridge’s silicone profile and subsequent performance, evaluated by friction forces. Four different scenarios were examined for comparative analysis. Table 7-2 below describes the differences in samples that were siliconized. Each sample was siliconized and baked under the same circumstances with identical process parameters.

Table 7-2: Washing Effect Sample Groups

Scenario 1	Scenario 2	Scenario 3	Scenario 4
<i>No Treatment:</i> Cartridge taken from supplier packaging, no washing or pre-treatment	<i>Water Washed:</i> Cartridge washed in deionized water bath for 30sec then blown out with compressed air to dry	<i>Alcohol washed:</i> Cartridge washed with alcohol soaked, dust-free paper towel then then blown out with compressed air to dry	<i>APP treated:</i> Cartridge treated with APP by SEP, vacuum packed, stored for four weeks, unpacked prior to siliconization

Cartridges were siliconized in partnership with Bosch® at their facility in Crailsheim, Germany. The test rig used is a pressure-time system and key parameter settings include silicone emulsion of 3.2%, atomizing pressure of 1.2 bar and silicone emulsion pump pressure of 0.45 bar.

7.5.2 Experimental Results

As described in Chapter 4, the key measurement used to evaluate performance in this study was not absolute friction forces but variation in forces. Reducing variation in friction forces allows for more consistent performance and opportunity for improved design flexibility. For context, the average absolute forces measured for the sample set are reported in Table 7-3.

Table 7-3: Absolute Friction Force Measurements

Data set includes 10 samples from each method (N=40)	
Average Gliding Force (N)	2.81
Average Break Loose Force (N)	3.50
Average Max Gliding Force (N)	3.61
Max Force in entire Data Set (N)	5.62

Figure 7-7 shows the results from the study, comparing variation among samples within a method. Given the small data set, these results do not demonstrate significant differences between methods. The APP treated samples do show the lowest variation in break loose forces and maximum gliding force encountered; however, the difference in variation is quite small. The untreated, unwashed cartridges show slightly higher variation, indicating washing likely does have an impact on silicone profile and resulting friction forces. However, comparing water washed, alcohol washed and APP treated cartridges, the variation differences in average gliding and break loose forces are almost non-existent.

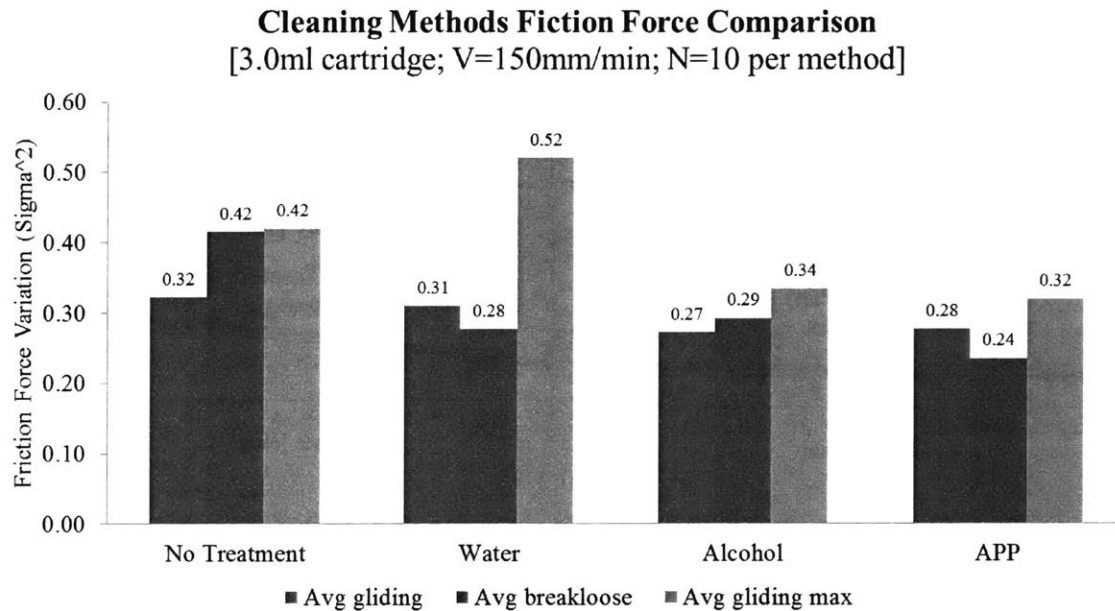

Figure 7-7: Variation Comparison for Cleaning Methods

The complete gliding force profiles for the first and second data set (N=5 for each method in each set) are shown in Figure 7-8 and Figure 7-9 to compliment the variation comparison presented in Figure 7-7. These gliding force profiles do not show significant differences between methods.

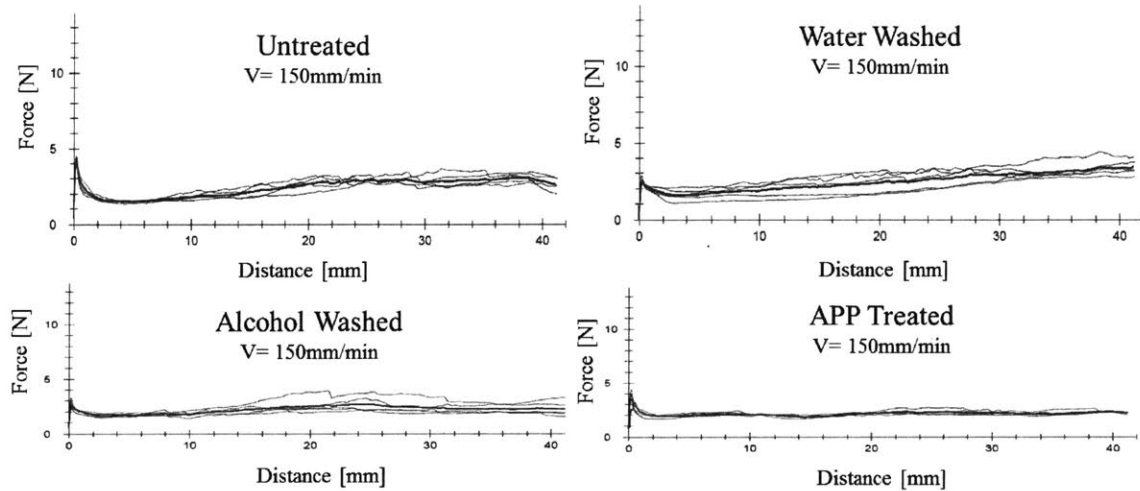

Figure 7-8: Gliding Force Profiles Washing Study Set 1

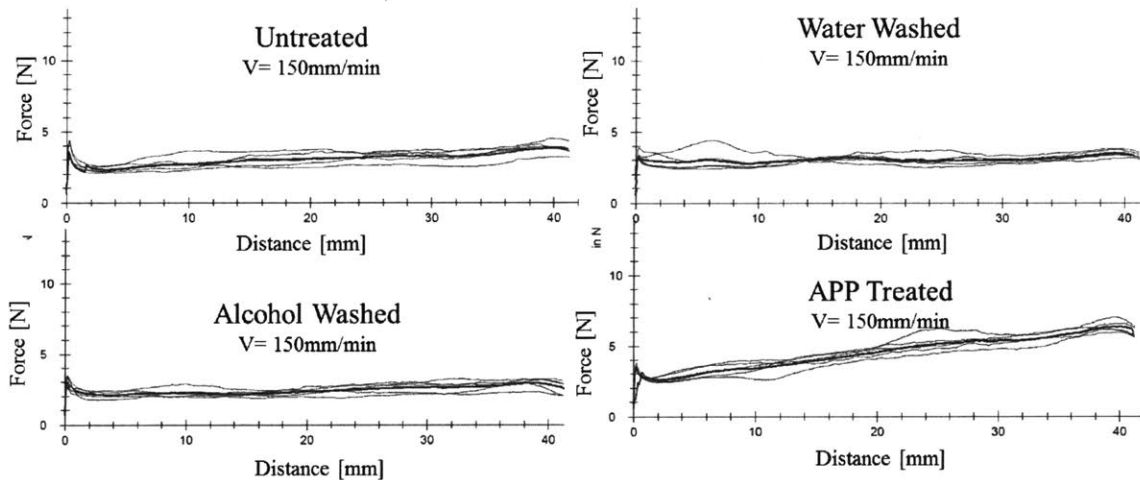

Figure 7-9: Gliding Force Profiles Washing Study Set 2

Accompanying these results, the silicone profiles evaluated by rap.ID analysis did not show significant differences in silicone uniformity, dry spot reduction or general profile attributes. A sample silicone profile for each method is shown below in Figure 7-10. It does appear that there is slightly better coverage in the upper portion of the cartridge in the APP treated cartridges. More rap.ID images for this study are included in Appendix F.

Untreated | Water Washed | Alcohol Washed | APP Treated

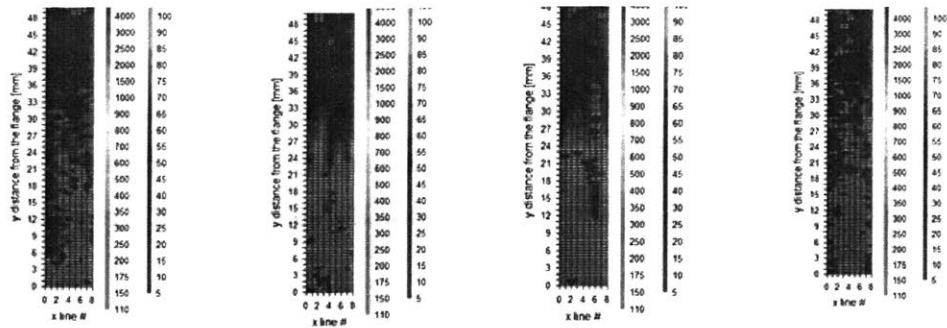

Figure 7-10: Sample rap.ID Results for Washing Study

Based on the rap.ID and friction force analysis, no significant differences were observed. Therefore these results fail to confirm the hypothesis that APP treatment improves siliconization and friction force variability. A second study was designed and executed to evaluate the effect of APP treatment by siliconizing treated and untreated cartridges under varying conditions. Results from this study also showed no statistical difference between cartridges that had been treated with APP and untreated cartridges, further supporting the result that APP does not improve silicone profile or friction force variation.

7.6 Effect of APP Treatment over Time and Conclusions

7.6.1 Initial Conclusions

The effects of APP treatment on glass were quite dramatic when evaluated by surface contact angle reduction and wettability increase. The roughness measurements showed a slight increase in surface roughness of APP treated cartridges though surface topography showed no discernable difference. The studies designed to measure the impact on siliconization and subsequent friction force variation showed no differences between APP treated and untreated cartridges. These results are troubling because they do not agree with one another. The results from surface angle measurements and wettability should complement the results from siliconization studies, but in fact they do not seem to be correlated at all.

This information suggests that APP treatment increases the surface energy and wettability of glass, but that the increase in these properties does not impact how silicone distributes on the inner surface of glass cartridges. No significant differences in measured friction variation confirms these results and suggests APP is not a viable form of pre-treatment for cartridges to improve silicon profile or friction force variation. However, this conclusion is missing a key piece of information, which, when considered holistically, explains the results described in this chapter.

The quantitative contact angle measurements were taken immediately before and after APP treatment. These showed a significant effect. The qualitative wettability analysis described by Figure 7-3 was performed with an APP treated cartridge immediately after treatment. This showed a significant effect. The surface imaging and roughness analysis was done with APP treated cartridges that had been treated about four weeks prior to analysis. These results showed little differences. The cartridges used for the final test were siliconized, baked and evaluated about four weeks after APP treatment. These results showed no difference between treated and untreated cartridges. A possible reason for the lack of consistency in results is that the effects of APP treatment wear off over time.

7.6.2 Effect of APP Treatment over Time

To explore this potential explanation, the effect of APP treatment over time was tested using contact angle measurements performed by SEP. Flat plate glass samples were APP treated on both sides, then vacuum packed with the same packaging used for the cartridges sent to Sanofi for siliconization. Samples were unpacked at regular time intervals and contact angles were measured. Results are presented in Figure 7-11.

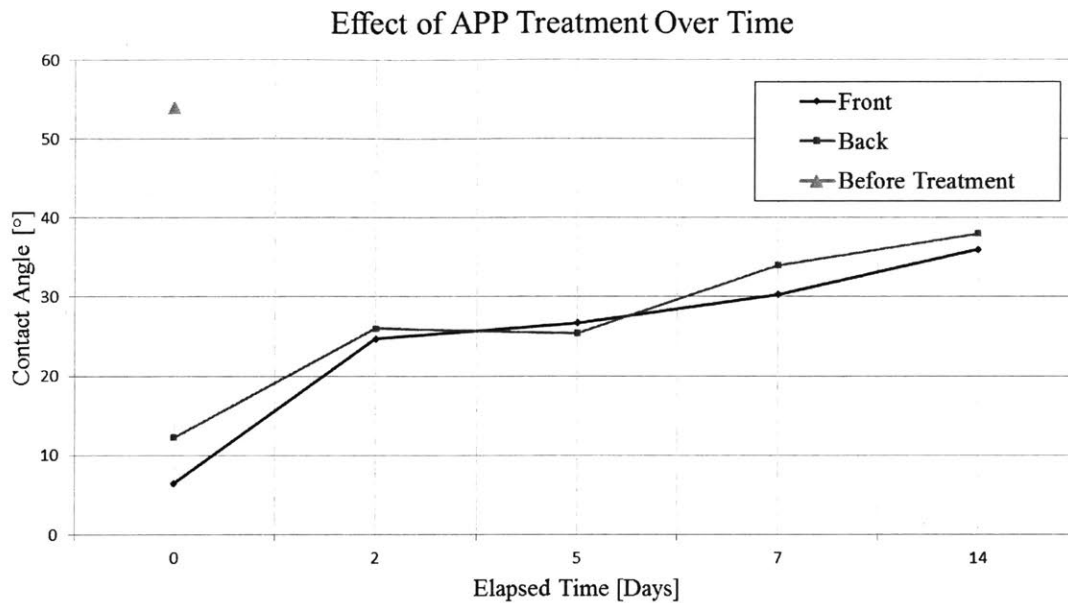

Figure 7-11: APP Treatment over Time

These results prove that the effect of APP treatment diminishes over time, even when stored in vacuum packed plastic. For these samples, prior to treatment contact angles were measured at 54°. Immediately following treatment, contact angles were measured at 8-12°; however, two weeks after treatment the contact angles had returned to 70% of their starting values. Extrapolating this time effect out to four weeks, when much of the analysis was done, the contact angles were likely between 40-45°, 80% of their untreated measurements. The results from this study show that the APP treated cartridges siliconized and tested were not effectively APP treated. This explains why little or no effect was observed between treated and untreated samples.

It is not fully understood why the APP effect wears off even when stored in vacuum packed plastic. It is possible that free radicals of small enough size are able to permeate the plastic and settle on the glass surface, effectively un-doing the valuable effect of APP treatment. What is now apparent is that in order to benefit from APP, APP treatment must be applied immediately prior to siliconization.

7.6.3 APP Treatment Conclusions

The results of this investigation show that APP treatment has significant impact on surface properties of glass. Specifically APP treatment increases the surface energy and wettability of glass. This is demonstrated quantitatively by the dramatic reduction in contact angles and qualitatively by the spreading of fluid on a treated surface. The other key conclusion from this investigation is that the effect of APP treatment on glass wears off over time. APP treated cartridges treated four weeks prior to siliconization did not show a significantly improved silicon profile, fewer dry spots or a decrease in friction variation during simulated injection. In order to evaluate the impact of APP treatment on silicone profile and friction force variation, cartridges need to be APP treated immediately prior to the siliconization step.

8 Conclusions and Recommendations

8.1 Impact and Key Findings

Insulin injection pens are used by millions of diabetic patients every year [5]. Their performance and reliability are paramount to ensuring patients can receive the treatment they need. Siliconization is an important aspect of that performance that can either hinder it or contribute to it. The characteristics of a cartridge's silicone profile dramatically impact its friction force profile. Sanofi currently has several filling lines used to siliconize cartridges and these methods produce different profiles and friction forces. This investigation has described those differences and drawn correlations between silicone profile and friction forces. Using those correlations, recommended parameters that define a 'good' siliconization profile have been presented. Atmospheric Pressure Plasma treatment has been explored for its impact on glass surfaces and its potential to improve silicone distribution, resulting in fewer dry spots. Finally a theoretical analysis was done to describe the lubrication regime of this application and is presented in Appendix G.

8.2 Filling Line Characterization

The characterization of three key filling lines was undertaken to gain insight into the differences between siliconization methods and the silicone profile they produce. The key take away is that different filling lines are producing cartridges with different silicone profiles. The core analysis focused on filling lines A, B, C but filling lines D and E which share a siliconization method with line A were also characterized. Filling lines A, B, C produced cartridges with different silicone profiles, line A having the lowest average layer thickness and the highest percent of dry spots. Filling line C had the highest average layer thickness and lowest percent of dry spots. Line C cartridges, when tested with simulated injection had the lowest variability in friction force measurements, a desirable characteristic whereas line A cartridges showed a high degree of variability. This correlation was identified between silicone profile parameters and friction force through filling line characterization. The relationship was then explored to further develop specific correlations and recommendations.

Process parameters and operating set-points for each siliconization method were collected in an attempt to understand which process set-points might be contributing to the type of silicone profile being produced. The collection of this information is important to have a complete picture of the system and all the potential factors that impact siliconization. As this project moves into its next stage, there is an opportunity for these operation set points to be collected and examined in further detail.

8.3 A Good Siliconization Profile

8.3.1 Defining a Good Siliconization Profile

The most significant result of this investigation is that a silicone profile target has been set for 3.0ml cartridges. It has been demonstrated that achieving a silicone profile, regardless of method, that meets the criteria specified can have a dramatic improvement on friction force variation. The two parameters used to define this silicone profile are average layer thickness and percent of dry spots. Both these metrics are measurable using the rap.ID layer explorer. A good silicone profile is one that has an average silicone layer thickness greater than 60nm and with fewer than 20% dry spots. To reiterate, a dry spot is defined as a data point measuring a layer thickness below 30nm. Figure 8-1, previously presented in Chapter 6, shows the data set used to set these parameter limits and describes the subsequent friction forces associated with cartridges that fit and do not fit the recommended profile.

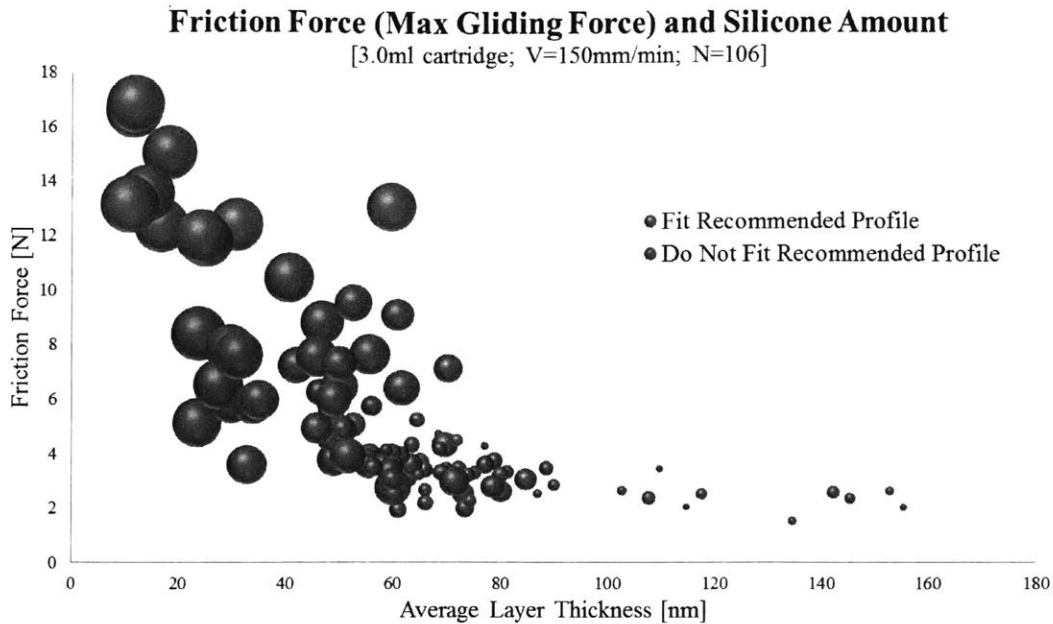

Figure 8-1: Cartridge Samples Achieving a ‘Good Silicone Profile’

For this particular data set, the result of achieving a good silicone profile was an 18x reduction in maximum gliding force variance. This improvement, if achieved on the filling lines, has the opportunity to improve device performance consistency and allow for more design flexibility.

This data was collected under specific circumstances and therefore the recommendations set forth apply most specifically under those circumstances. The data was measured using siliconized and baked 3.0ml cartridges collected from five filling lines at Sanofi prior to filling running under normal operation. They were evaluated for silicone profile characteristics using rap.ID layer explorer with 900 data points measured per cartridge. Friction forces were measured by testing empty cartridges with a manually inserted standard rubber stopper at a velocity of 150mm/min. However, it is believed that under similar circumstances this recommendation will hold, including application for 1.5ml cartridges and injection speeds between 50 - 350 mm/min.

8.3.2 Future Opportunities for Silicone Profile and Friction Correlations

There is certainly an opportunity to expand the data set to test, confirm and adjust the recommended parameters. Furthermore, data sets could be built under varying conditions such as cartridge geometry and testing methods. The most relevant testing methods are ones that most accurately simulate real application in the consumer device. In addition to these opportunities, there is still significant work to be done to correlate specific silicone profiles with resulting friction forces. The investigation presented here relied on aggregate data more than individual samples; however, there are clear relationships that can be observed when looking at individual samples. Figure 8-2, previously presented in Chapter 4, shows three friction force profiles for three silicone profiles produce by the three different siliconization methods. These cartridge samples were identified and are shown because of their clear differences.

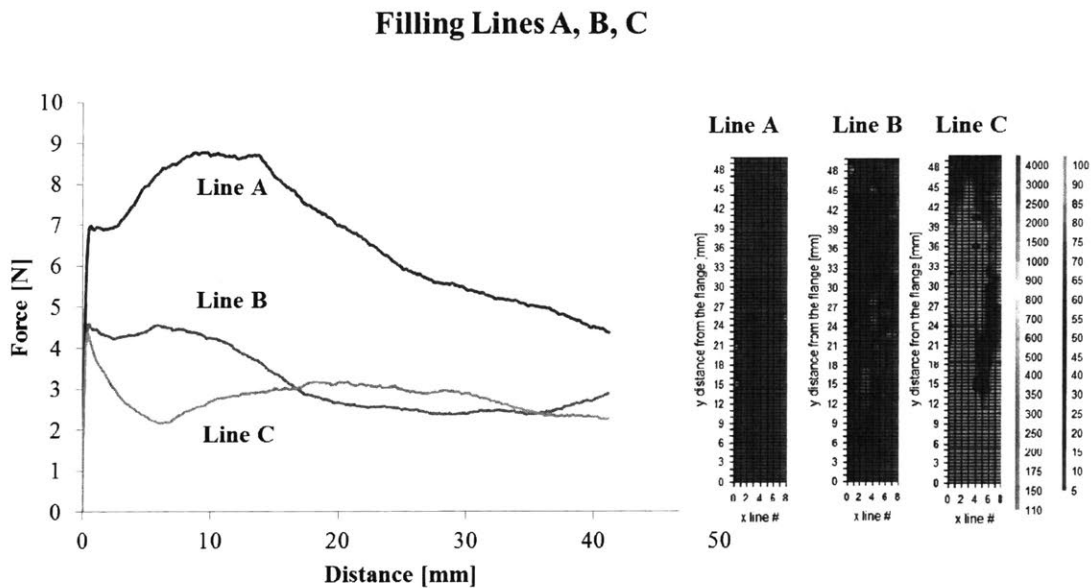

Figure 8-2: Correlating Silicone and Friction Force Profiles Individually Example 1

These gliding force profiles are almost intuitively what would be expected given their silicone profile as described using rap.ID analysis. The challenge is that this consistency is not always observed. There are some sample cartridges that do not produce the type of gliding force profile that might be expected given its silicone profile. Another representation of the type of analysis that could be taken further is shown in Figure 8-3.

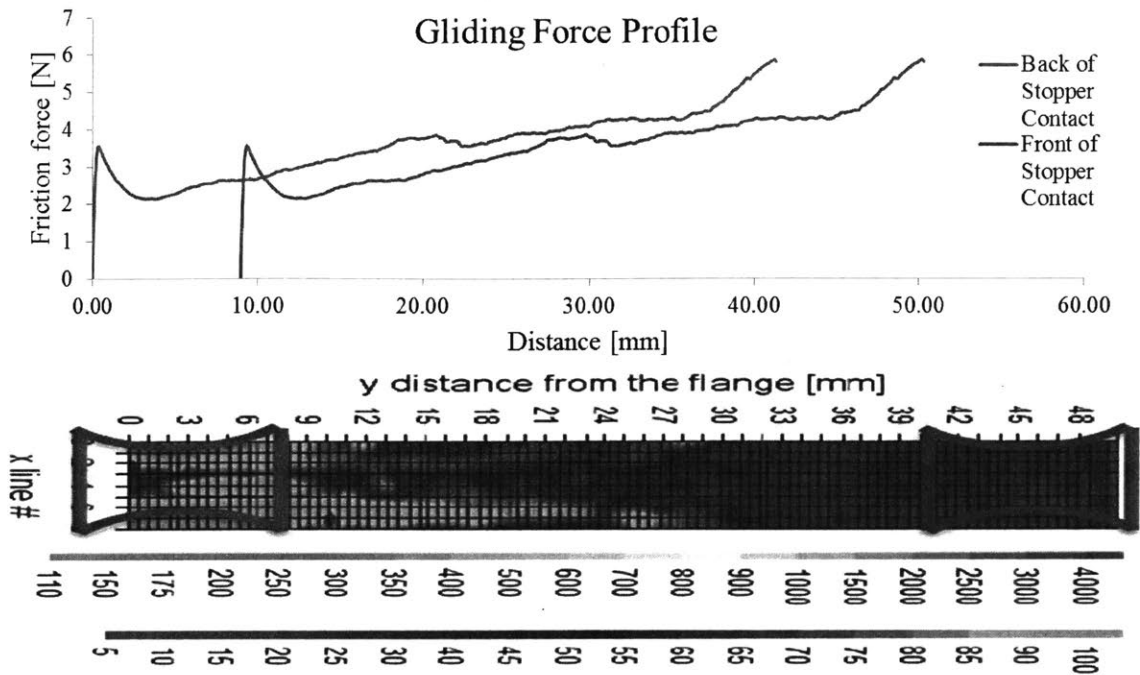

Figure 8-3: Correlating Silicone and Friction Force Profiles Individually Example 2

This example of a correlation shows the potential to track forces associated with silicone profile properties such as thickness and distribution millimeter by millimeter as a rubber stopper is pushed through a cartridge. In this specific example the force increases as the layer thickness of silicone decreases as the stopper is pushed further along the cartridge. This result is also in-line with expectations that a lower silicone thickness results in higher friction forces. But again, this relationship is not always so clearly observed, indicating there are more intricacies and molecular level interactions that these analysis methods cannot currently capture. Investigation into these is described briefly in Appendix G but significant opportunity for further understanding exists in this area.

Finally, another area of investigation relating to silicone profile and friction force correlations that would be valuable is better understanding how true dry spots effect friction force in the cartridge geometry. Schacherl showed in his work that they can be quite significant [17]. Understanding what size and geometry of dry spots are important to avoid and if they are occurring on the filling lines would help inform future optimization efforts.

8.4 Atmospheric Pressure Plasma Treatment

8.4.1 APP Key Findings

The hypothesis that APP treatment of glass cartridges prior to siliconization will improve silicone profile resulting in more consistent friction forces was tested. It was expected that APP treatment would increase glass wettability, improving silicone distribution and partially eliminating dry spots. The results showed that APP treatment does increase glass surface energy and improve wettability, but that this effect wears off over time. After two weeks of storage in vacuum sealed packaging, the surface energy (measured by contact angle) reverts to 70% its original value. It is expected that under less conservative storage, the effect wears off even more quickly.

APP treated cartridges that were siliconized, baked and evaluated on the basis of silicone profile and friction forces showed no significant improvement as compared to untreated cartridges. However, because APP wears off over time, the APP treated samples tested were effectively untreated, making the study inconclusive. The experiments failed to confirm or deny the hypothesis that APP treatment improves silicone profile and subsequent friction force variation.

8.4.2 APP Future Opportunities

Based on the dramatic wettability effect observed, future opportunities with APP are optimistic. Feasibility studies, similar to the ones performed and described in Chapter 7, should be done to effectively test the efficacy of APP treatment of glass cartridges. These tests should be performed by APP treating the glass immediately prior to siliconization with as little transition time between APP treatment and siliconization as possible.

A collaboration between the MIT Manufacturing and Productivity Lab and Sanofi has been formed to explore these opportunities in more detail. One approach includes MIT designing, building and testing a small scale, portable APP system at MIT. This system can then be sent to Sanofi's siliconization lab so that APP treatment and siliconization can be done sequentially with almost no storage time between the two steps. This partnership would allow for a true feasibility study to be designed to test the hypothesis that APP treatment improves silicone profile and friction force variability.

8.5 Process Optimization

This investigation has been aimed at furthering process knowledge and fundamentally understanding the relationship siliconization plays in device performance and quality assurance. With a more informed understanding of the key relationships, a recommended silicone profile has been established. This recommendation sets the stage for process optimization at Sanofi SFI. Achieving these recommendations will improve the consistency of cartridges and result in improved device performance; however, without making this silicone profile reproducible on the filling lines, the gains will not be achieved in practice or at scale. It is therefore a logical next step for the siliconization equipment on each filling line to be further characterized and optimized to produce the desired silicone profile for each cartridge in a repeatable process.

Optimization can be done at the lab scale with pilot siliconization equipment prior to full implementation on the filling lines. There are many parameters and factors that may be important to consider when trying to optimize siliconization. Some of these include silicone emulsion concentration, emulsion temperature, target siliconization amount, needle position, needle movement, baking temperature, baking time, air pressure, pump pressure, etc. With this number of variables a DOE can become very burdensome and hundreds of trials may be necessary to achieve statistically significant results. It will be key to select the parameters that impact the silicone profile the most. What has been demonstrated here is that the recommended silicone profile is achievable on several filling lines under current conditions, therefore some factors such as emulsion concentration need not be included in the optimization. Further selection of factors can allow for a more manageable design of experiments to be conducted. The information can then be used to inform directional impacts of parameters on friction forces. An example of this type of output is included in Figure 8-4.

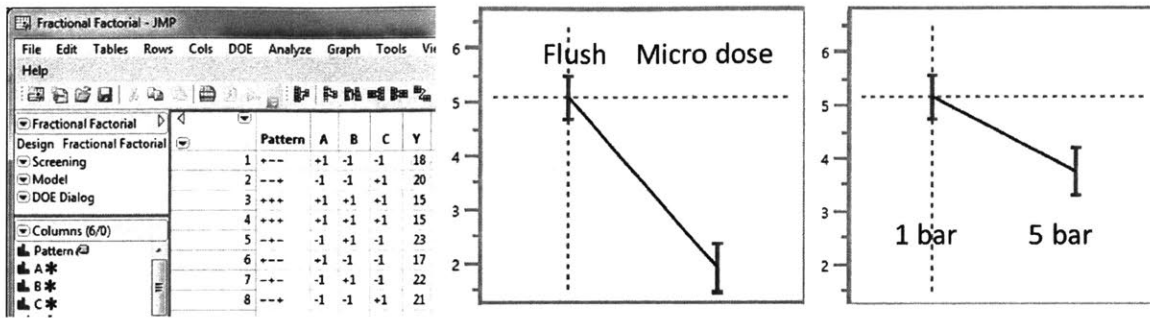

Figure 8-4: Example DOE Set-up and Output

This DOE was set up and executed in conjunction with APP testing. The tests runs were limited and select results are shown in Figure 8-4 as examples of the type of analysis DOE allows for. Once parameters for siliconization are optimized to meet the recommended silicone profile, they can be outfitted and adapted to the filling lines. Once all filling lines are able to produce cartridges with the recommended silicon profile many of the benefits gained from better understanding siliconization will be realized.

There is much more to be learned and understood about baked-in siliconization. Each iteration of siliconization research provides more knowledge that can inform and guide engineering and business decisions for Sanofi and the industry. Insulin pens provide the necessary therapy for millions of people around the world to manage their disease [5]. This thesis work aims to support the high quality and consistent performance critical to ensuring high functionality and performance of such devices.

9 References

- [1] Insights, Inc Global Market. "Antidiabetics Market Size worth USD 116 Billion by 2023: Global Market Insights Inc." *GlobeNewswire News Room*. N.p., 05 July 2016. Web. 24 Mar. 2017.
- [2] "Diabetes Injection Pens Market Is Expected to Be Worth US\$9.7 Billion by 2024 - Leading Players Operating Are Novo Nordisk A/S, Eli Lilly and Company, AstraZaneca Plc., Biocon Ltd., and Sanofi S.A." *AboutPharma*. Transparency Market Research, 08 Dec. 2016. Web. 23 Mar. 2017.
- [3] "SAN.PA : Summary for SANOFI - Yahoo Finance." *Yahoo! Yahoo!*, n.d. Web. 24 Mar. 2017.
- [4] "Sanofi - Healthcare Solutions." *Sanofi*. Accessed December 1, 2016. <http://en.sanofi.com/healthcare-solutions/healthcare-solutions.aspx>.
- [5] "WHO | Diabetes." *WHO*. Accessed December 1, 2016. <http://www.who.int/mediacentre/factsheets/fs312/en/>.
- [6] "Sanofi - Healthcare Solutions." *Sanofi*. Accessed December 1, 2016. <http://en.sanofi.com/healthcare-solutions/healthcare-solutions.aspx>.
- [7] "Technical Considerations for Pen, Jet, and Related Injectors Intended for Use with Drugs and Biological Products." U.S. Department of Health and Human Services, June 2013. <http://www.fda.gov/downloads/RegulatoryInformation/Guidances/UCM147095.pdf>.
- [8] "Sanofi - Diabetes." *Sanofi*. Accessed December 1, 2016. <http://en.sanofi.com/healthcare-solutions/diabetes/diabetes.aspx>.
- [9] "Medical Definition of AUTO-INJECTOR." Accessed December 1, 2016. <http://www.merriam-webster.com/medical/auto%E2%80%93injector>.
- [10] Colas, Andre, Jason Siang, and Kathy Ulman. "Silicones in Pharmaceutical Applications. Part 5: Siliconization of Parenteral Packaging Components." Technical Report 52-1094-01, Dow Corning Corporation, 2006. <https://cmd-www.dowcorning.com/content/publishedlit/52-1094-01.pdf>.
- [11] "Ripping Viscoelastic Fluids." Accessed December 1, 2016. <http://www.phy.olemiss.edu/~jgladden/rippingfluids/>.
- [12] Reuter B, Petersen C. Syringe Siliconization: Trends methods, analysis procedures. *TechnoPharm*. 2012;2(4):238-244.
- [13] Lorenz, B, B A Krick, N Rodriguez, W G Sawyer, P Mangiagalli, and B N J Persson. "Static or Breakloose Friction for Lubricated Contacts: The Role of Surface Roughness and Dewetting."

Journal of Physics: Condensed Matter 25, no. 44 (November 6, 2013): 445013.
doi:10.1088/0953-8984/25/44/445013.

- [14] “Gerresheimer Customer Newsletter.” Design and editing Gerresheimer Group Communication & Marketing, July 2015.
- [15] Jones LS, Kaufmann A, Middaugh CR. Silicone Oil induced aggregation of proteins. *J Pharm Sci* 2005; 94(4):918-927
- [16] Mundry, T, T Schurreit, and P Surmann. 2000. "The fate of silicone oil during heat-curing glass siliconization--changes in molecular parameters analyzed by size exclusion and high temperature gas chromatography." *PDA Journal Of Pharmaceutical Science And Technology / PDA* 54, no. 5: 383-397. *MEDLINE Complete*, EBSCOhost (accessed December 1, 2016).
- [17] Schacherl, Jeffrey. “Glass Siliconization Process Characterization for Insulin Delivery Device Performance.” Massachusetts Institute of Technology, 2016.
- [18] Bhushan, Bharat, Jacob N. Israelachvili, and Uzi Landman. “Nanotribology: Friction, Wear and Lubrication at the Atomic Scale.” *Nature* 374, no. 6523 (April 13, 1995): 607–16.
doi:10.1038/374607a0.
- [19] Rathore N, Pranay P, Eu B, Ji W, Walls E. Variability in syringe components and its impact on functionality of delivery systems. *PDA J Pharm Sci Technol.* 2011;65(5):468-480.
doi:10.5731/pdajpst.2011.00785.
- [20] Butt, Hans-Jürgen, Karlheinz Graf, and Michael Kappl. *Physics and Chemistry of Interfaces*. 2nd, Rev, Enl ed. Darmstadt: Wiley-VCH, 2010. Print.
- [21] Yazawa, Shuichiro, Ichiro Minami, and Braham Prakash. “Reducing Friction and Wear of Tribological Systems through Hybrid Tribofilm Consisting of Coating and Lubricants.” *Lubricants* 2, no. 2 (2014). doi:10.3390/lubricants2020090.
- [22] Stribeck, Richard, and Cylinder Cutaway. “Generating a Stribeck Curve in a Reciprocating Test (HFRR/SRV-Type Test).” Accessed December 1, 2016.
https://www.bruker.com/fileadmin/user_upload/8-PDF-Docs/SurfaceAnalysis/TMT/ApplicationNotes/AN1004_RevA2_Generating_a_Stribeck_Curve_in_a_Reciprocating_Test-AppNote.pdf.
- [23] Chan, Edwin, Aaron Hubbard, Samir Sane, and Yuh-Fun Maa. “Syringe Siliconization Process Investigation and Optimization.” *PDA Journal Of Pharmaceutical Science And Technology / PDA* 66, no. 2 (April 3, 2012): 136–50. doi:10.5731/pdajpst.2012.00856.
- [24] “Our History « Atmospheric Plasma Treatment with High Speed Plasma System – SurfX Technologies.” Accessed December 1, 2016. http://www.surfstechnologies.com/about_us/our-history/.

- [25] Štěpánová, Vlasta, Pavel Slaviček, Miroslav Valtr, Vilma Buršíková, Monika Stupavská, and others. "Improvement of Glass Wettability Using Diffuse Coplanar Surface Barrier Discharge and Gliding Arc Considering Aging Effect," 2015.
<http://www.nanocon.eu/files/proceedings/23/papers/4546.pdf>.
- [26] Ting, Julie Anne S., Leo Mendel D. Rosario, Henry V. Lee, Henry J. Ramos, and Roy B. Tumlos. "Hydrophobic Coating on Glass Surfaces via Application of Silicone Oil and Activated Using a Microwave Atmospheric Plasma Jet." *Surface and Coatings Technology* 259 (November 2014): 7–11. doi:10.1016/j.surfcoat.2014.08.008.
- [27] SEP Company, Dr. Sang-Ro Lee, *Communication March through August 2016*
- [28] "Surface Energy and Surface Tension." Accessed December 1, 2016.
<http://www.adhesiveandglue.com/surface-energy.html>.
- [29] "Wetting." Accessed December 1, 2016.
<http://web.mit.edu/nmf/education/wettability/wetting.html>.
- [30] "rap.ID Technical Paper." rap.ID Particle Systems, 2011.
- [31] BRAUN, Franziska. "FRA-SOP-02117," March 27, 2014.
- [32] "Hooke's Law and Circular Motion." MIT, September 2004.
- [33] Persson, B., N. Prodanov, B. Krick, N. Rodriguez, N. Mulakaluri, W. Sawyer, and P. Mangiagalli. 2012. "Elastic contact mechanics: Percolation of the contact area and fluid squeeze-out." *European Physical Journal E -- Soft Matter* 35, no. 1: 1.
- [34] American Society of Mechanical Engineers, ed. *Surface texture: (surface roughness, waviness, and lay) ; an American standard*. New ed. ASME American standard, B-46.1. New York, NY: ASME, 2010.
- [35] Mittal, K. L., W. J. Van Ooij, and H. R. Anderson, eds. *First International Congress on Adhesion Science and Technology: Invited Papers: Festschrift in Honor of Dr. K.L. Mittal on the Occasion of His 50th Birthday*. Utrecht, The Netherlands: VSP, 1998.

Appendix

Appendix A: Rap.ID Data Translated

The basic geometry of the 3.0ml cartridges collected from the filling lines can be visualized below:

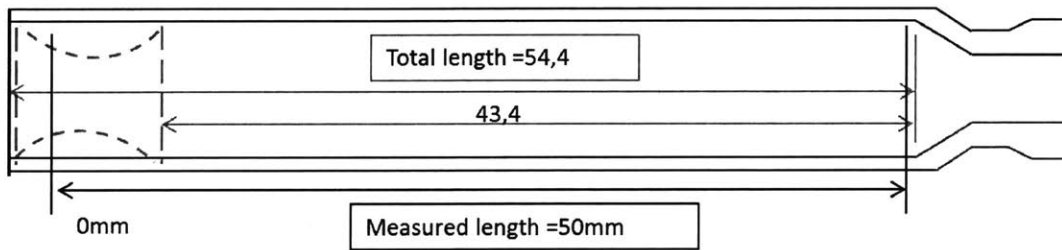
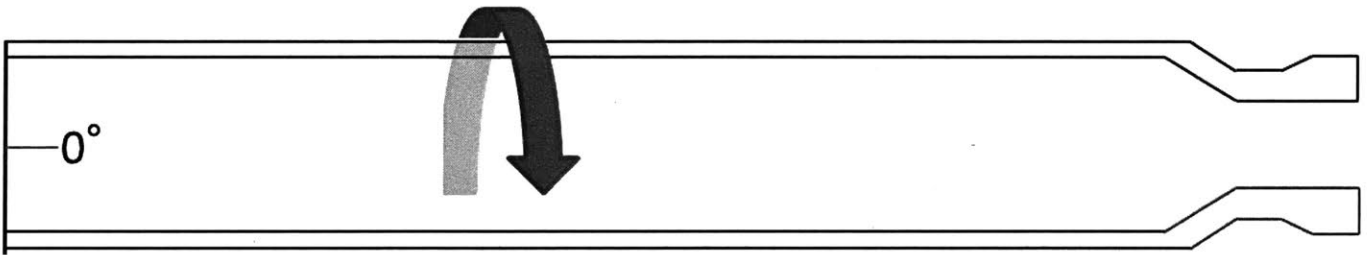
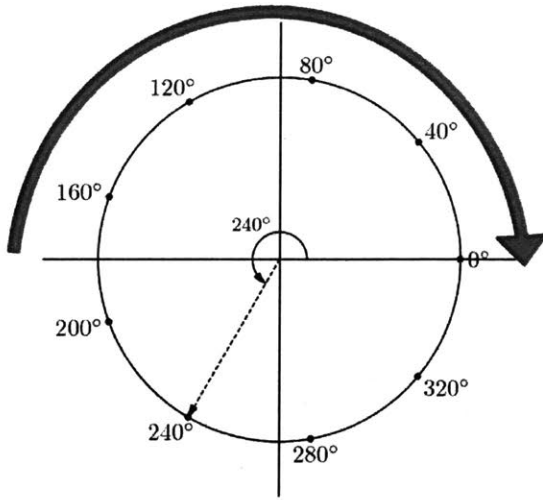

Figure: 3.0ml cartridge

Nine lines, each with a length of 50mm and 100 data points per line are measured at 40° intervals around the cartridge's inner surface circumference. These 900 measurements provide a representation of the silicone layer height and profile distribution on the inner surface of the cartridge. The data is translated to the real geometry using the below information.

#	mm	#	mm	#	mm	#	mm	#	mm
0	0,00	20	10,10	40	20,20	60	30,30	80	40,40
1	0,51	21	10,61	41	20,71	61	30,81	81	40,91
2	1,01	22	11,11	42	21,21	62	31,31	82	41,41
3	1,52	23	11,62	43	21,72	63	31,82	83	41,92
4	2,02	24	12,12	44	22,22	64	32,32	84	42,42
5	2,53	25	12,63	45	22,73	65	32,83	85	42,93
6	3,03	26	13,13	46	23,23	66	33,33	86	43,43
7	3,54	27	13,64	47	23,74	67	33,84	87	43,94
8	4,04	28	14,14	48	24,24	68	34,34	88	44,44
9	4,55	29	14,65	49	24,75	69	34,85	89	44,95
10	5,05	30	15,15	50	25,25	70	35,35	90	45,45
11	5,56	31	15,66	51	25,76	71	35,86	91	45,96
12	6,06	32	16,16	52	26,26	72	36,36	92	46,46
13	6,57	33	16,67	53	26,77	73	36,87	93	46,97
14	7,07	34	17,17	54	27,27	74	37,37	94	47,47
15	7,58	35	17,68	55	27,78	75	37,88	95	47,98
16	8,08	36	18,18	56	28,28	76	38,38	96	48,48
17	8,59	37	18,69	57	28,79	77	38,89	97	48,99
18	9,09	38	19,19	58	29,29	78	39,39	98	49,49
19	9,60	39	19,70	59	29,80	79	39,90	99	50,00



Line number	0	1	2	3	4	5	6	7	8
Angle	0°, 360°	40°	80°	120°	160°	200°	240°	280°	320°

Because the Layer Explorer has a lower limit of detection at 15-20nm, it is not possible to know the silicone thickness below this point. Furthermore, the accuracy error of the UT measurement system is reported by rap.ID® to be +/- 15nm in the range of 20-150nm [30]. The amount of time to measure a single cartridge with this resolution is forty minutes, and is done with minimal intervention by the user.

Appendix B: Rap.ID Images

Rap.ID Images – Data Set 1

Line B

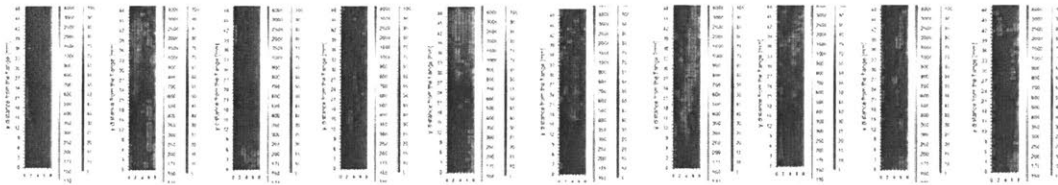

Line A

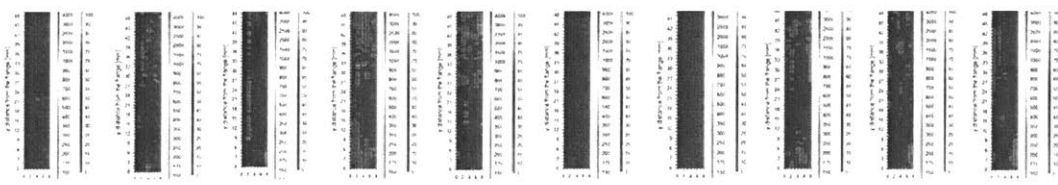

Line C

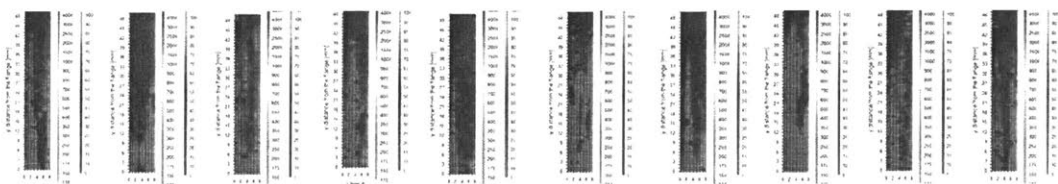

Rap.ID Images – Data Set 2

Line B

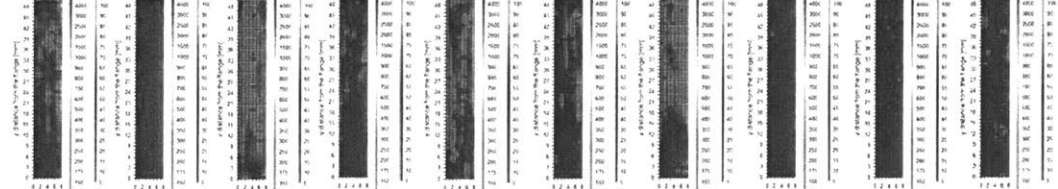

Line A

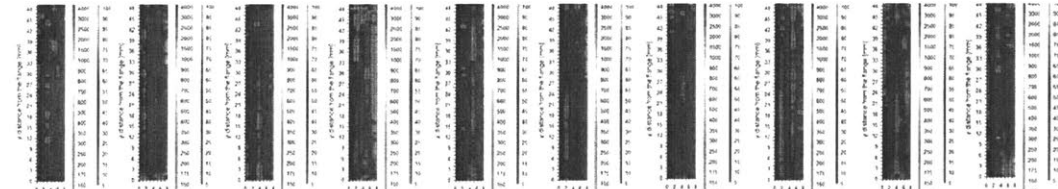

Line C

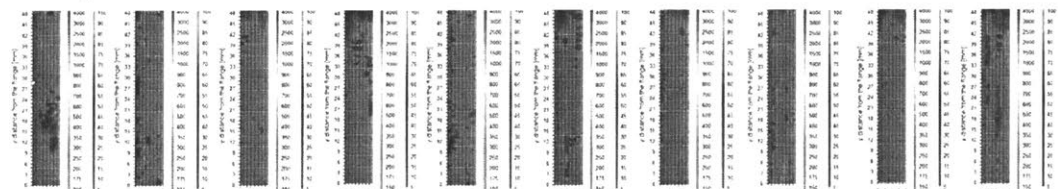

Appendix C: Friction Force Testing Methods

The amount of variation did not change significantly with different testing speeds. The break loose and gliding forces increased with a higher velocity as expected, indicating a relationship between velocity and friction forces. The velocity of 150 mm/min was selected for the majority of measurements to ensure consistency.

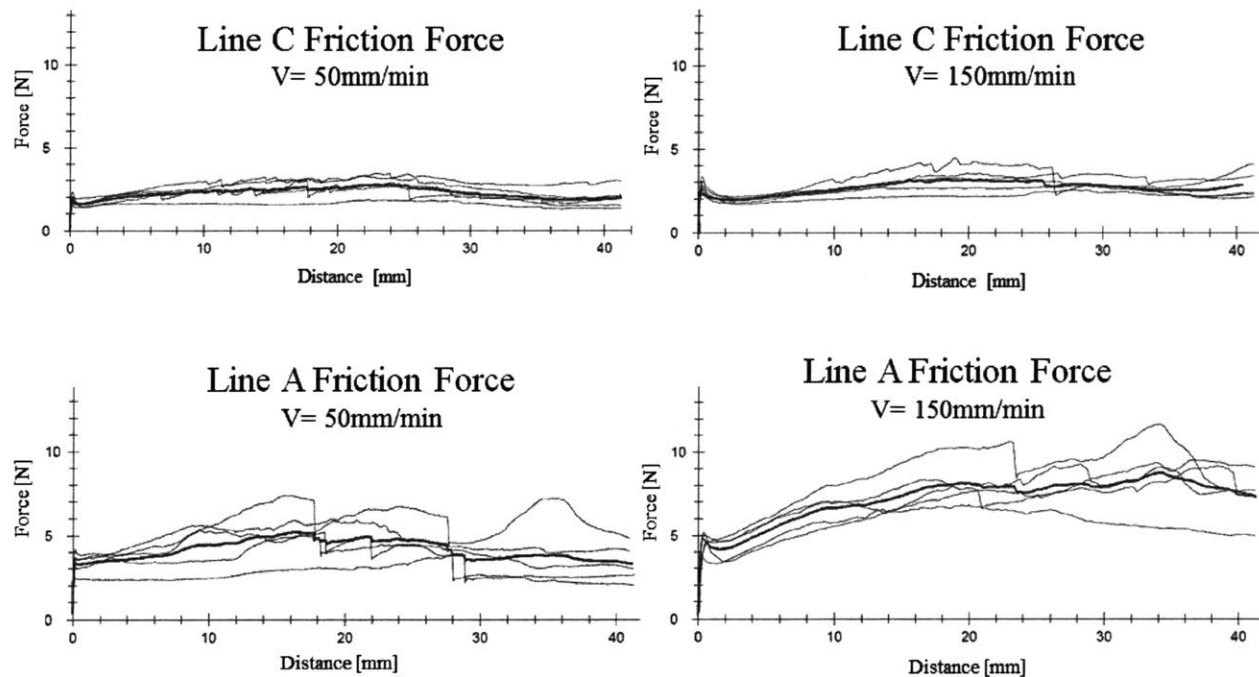

Figure: Effect of Testing Speed

The use of a needle significantly increased friction force due to the expected hydrodynamic contribution previously discussed. The effect was more dramatic at 150 mm/min testing speed because hydrodynamic force increases linearly with velocity.

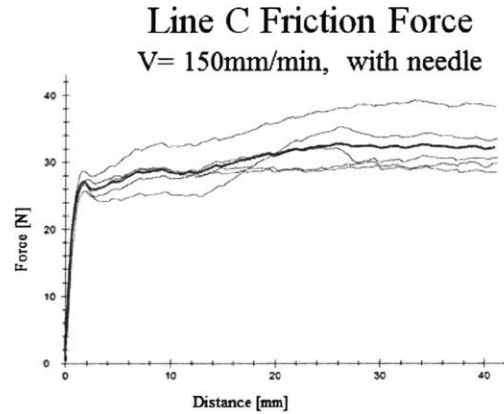
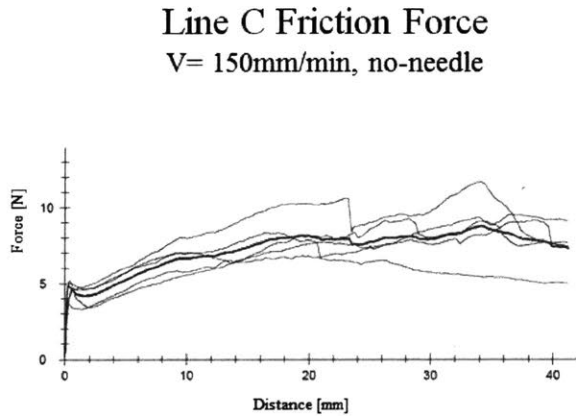
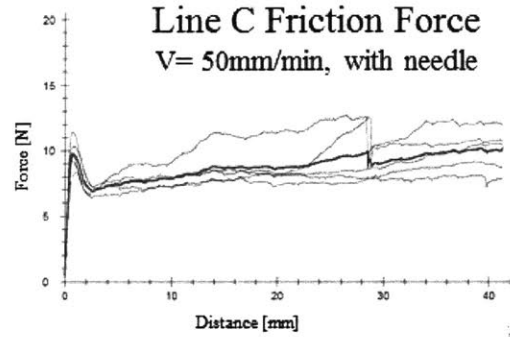
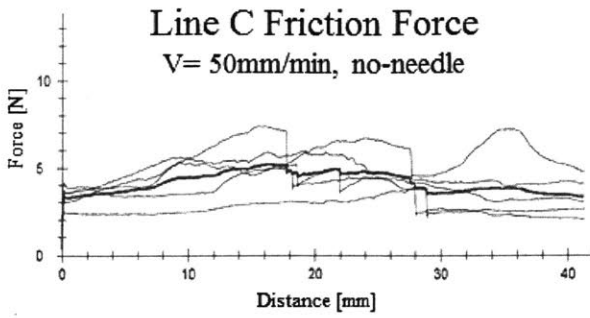

Figure: Effect of Needle

One drawback to measuring without a needle is that the rubber stopper during actual injection is more compressed than in the measurement method described here. The hydrostatic pressure created in the barrel during injection exerts a force on the rubber stopper in the opposite direction of the driving force, effectively compressing the stopper laterally and increasing radial normal force. Again, however, all comparative tests were performed without a needle to remove needle differences as a source of error. This was achieved by testing cartridges extracted from production after the siliconization and baking step but before the cartridge is filled with Insulin.

Appendix D: Dimensional Considerations

A potentially significant source of error comes from material dimensional differences related to cartridge and rubber stopper tolerances. The analysis that follows is applicable for dry friction, and as such describes the largest amount of variability attributable to dimensional differences that might be seen throughout experimentation. Because this application is not operating in 100% dry friction, any benefit from lubrication will reduce the impact of this variability because as we move from dry friction towards hydrodynamic lubrication the impact of normal force on friction force decreases significantly.

From Equation 3-1 ($F_{friction} = \mu F_{normal}$), the inherent characteristic used to describe friction between two materials is the coefficient of friction, thus to control results, testing should be performed with equal normal forces. This, however, is challenging to accomplish in practice and serves as a source of variability in this works experimentation and results.

To quantify this variability, the specs for the glass cartridge inner diameter is $9.6 \pm 0.1\text{mm}$ and for the rubber stopper the outer diameter spec (without compression) is $10.0 \pm 0.1\text{mm}$. Because the materials tested come from this pool, it is possible to have two extremes and all possibilities in between. To see the potential impact of these differences, below walks through the process to calculate theoretical normal forces resulting from the two extremes and a dimensionally perfect combination of cartridge and rubber stopper.

$$F_n = \sigma * A \quad (D-1)$$

where F_n is the normal force of the rubber stopper on the glass cartridge, σ is the normal stress [N/mm^2] and A is the apparent area of contact. Normal stress can be defined by:

$$\sigma = \epsilon * E \quad (D-2)$$

where ϵ is strain and E is the elasticity or Young's modulus. ϵ is a dimensionless number defined for cylindrical geometry as:

$$\epsilon = \frac{\text{Change in diameter}}{\text{Original diameter}} \quad (D-3)$$

Young's modulus is assumed to be constant, which is generally true for rubber, with a value of 11.7 N/mm^2 [35]. Strain can be calculated by the compression required by the rubber stopper due to diameter overlap between the rubber stopper and the glass cartridge. It is assumed that the glass is ridged and does not compress, which is true under these low normal forces. Finally the apparent area of contact was measured using an optical microscope, observing where the rubber stopper is compressed against the glass inner surface and calculating surface area of the cylindrical sides. The average height of contact area from ten samples was measured to be $1.81\text{mm} \pm 0.16$. The apparent area of contact decreases when the overlap is the greatest because the diameter of the cylinder is smaller; however, it is likely that under increased compression the height of the compressed regions increases effectively increasing the area of contact. Because there is not a reliable method to measure this, the effect is assumed to be accounted for in the sample measurements taken is not included in the theoretical calculation.

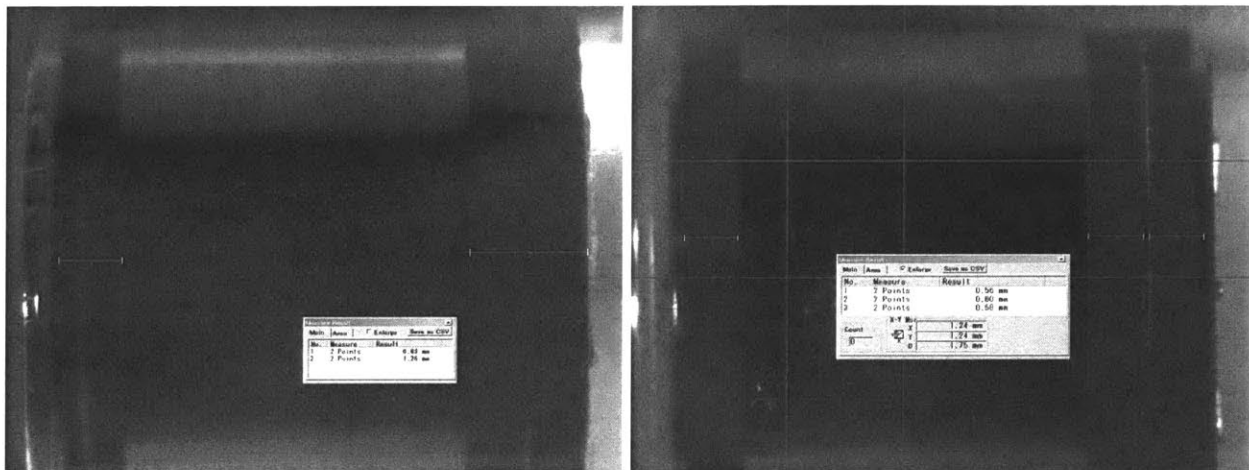

Figure: Rubber Stopper Contact Area inside Two Cartridges

With these parameters, the theoretical normal force for the design dimensions and the minimum and maximum dimensional overlap is calculated and shown in the table below. It is important to observe the range of normal forces possible based on dimensional differences.

Calculating Theoretical Normal Force of Rubber Stopper

Dimension overlap between cartridge and stopper	Diameter Overlap [mm]	Strain (relative change)	Young's Modulus [N/mm ²]	Area of Contact (mm ²)	F _n (N) Calculated	Change from Standard
Minimum	0.20	0.02	11.70	55.19	13.04	-49%
Standard Specs	0.40	0.04	11.70	54.62	25.56	--
Maximum	0.60	0.06	11.70	54.05	37.57	47%

Assuming a friction coefficient of 0.2 for siliconized glass, the dimensional impact on friction force ranges can be seen in the table below. To think about it another way, if friction force is measured to be 5.00 N for three sample cartridges, the frictional impact of the siliconization, specifically the friction coefficient could be between 0.13 and 0.38, almost a 3-fold difference. This wide range makes it challenging to make conclusive statements about how siliconization affects friction.

Theoretical Dimensional Effects on Friction⁴

Overlap	Friction Coefficient, μ	Normal Force (N)	Friction Force (N)
Minimum	0.20	13.04	2.61
Nominal	0.20	25.56	5.11
Maximum	0.20	37.57	7.51
Minimum	0.38	13.04	5.00
Nominal	0.20	25.56	5.00
Maximum	0.13	37.57	5.00

⁴ These calculations are descriptive for dry friction ($F = \mu F_{\text{Normal}}$) and represent a 'worst case' impact.

While it is not expected that these extremes occur frequently, it is important to understand the potential impact. Because of this source of variability, friction forces measured with this method need to be compared using larger sample sets on the basis of averages. Furthermore comparisons between individual cartridges cannot confidently be made regarding siliconization impact on friction forces alone.

Another possible source of variability is the difference in the degree of siliconization of the rubber stopper. The rubber stoppers are also siliconized and since different stoppers were used for each friction test, it is possible that this could add further error to the results. These sources of error certainly present challenges when trying to develop relationships between siliconization and friction forces by comparing cartridges; however, these sources of variability are spread throughout every sample set and thus comparisons can still be made and results collected.

Appendix E: Siliconization Method Steps

Summary of Washing and Siliconization Steps

A - Flushing	B – Time pressure	C – Micro dose
Ultrasonic bath with WFI*	Ultrasonic bath with WFI	Inside and Outside Pre-wash with circulated water
Outside and inside flushing with water	Outside and inside flushing with water	Blow out with compressed air (inside)
	Blow outside with compressed air	Inside washing with WFI
Final Rinse with WFI	Final Rinse with WFI	Inside and outside washing with WFI
Blow out with compressed air (inside)	Blow out with compressed air inside and outside	Blow out with compressed air (inside)
Flushing siliconization	Time pressure siliconization	Micro dose siliconization
Blow out with compressed air (inside)		
Outside flushing with WFI	Outside flushing with WFI	Outside flushing with WFI
Drying outside with compressed air	Drying outside with compressed air	Drying outside with compressed air
Baking: 290-320°C, 15-90mins	Baking: 320°C, 15-90mins	Baking: 290°C, 15-270mins

*WFI = Water for Injection (purified water by steam condensation)

Appendix F: APP Study rap.ID Images

Rap.ID Images: Washing Study (Set 1)

Alcohol Washed

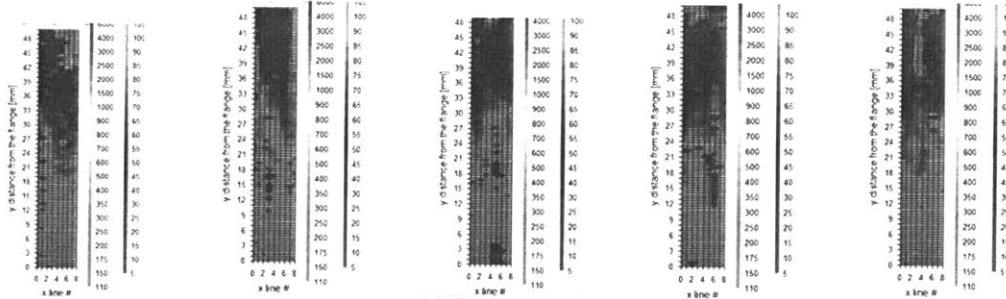

APP Treated

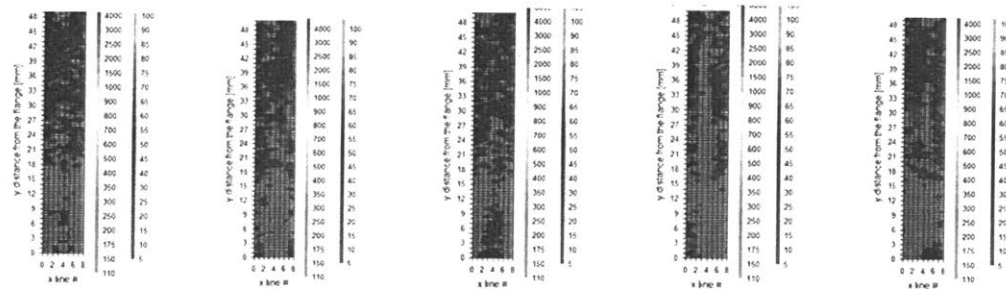

Untreated

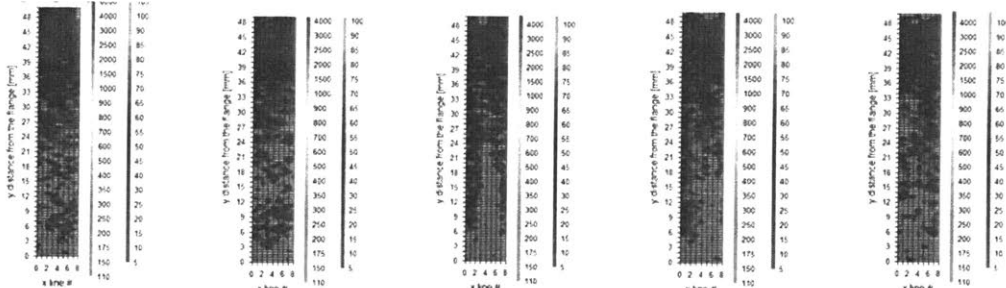

Water Washed

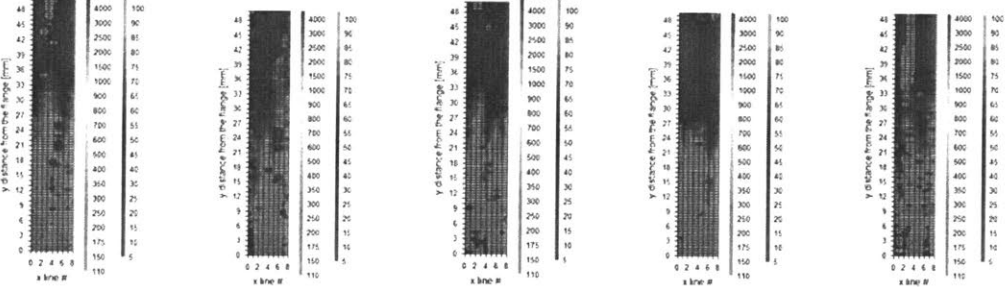

Appendix G: Theoretical Evaluation of Friction and Lubrication Properties

Introduction

As described in Section 3.2, the fundamental physics governing this application include friction, lubrication and fluid dynamics. Developing a better understanding of what is physically happening will help guide optimization efforts as well as design decisions for future primary packaging materials. This appendix section describes work that was done combining measurements and experimentation with theoretical descriptions of friction and lubrication. This analysis serves as a one perspective approach and a starting point to begin to understand more fundamentally what is happening during injection as the rubber stopper is pushed through the baked-in silicone coated glass cartridge and through the needle. First the relative significance of friction in this application is described, followed by surface roughness analysis aimed at describing on friction and lubrication on the nanoscale.

Relative Impact of Friction

As described in Chapter 3, there are two key components to the force opposing the rubber stopper during injection, friction and hydrodynamic.

$$F_{total} = F_{friction} + F_{hydrodynamic} \quad (G-1)$$

Equation G-2 is used to approximate the hydrodynamic force, where η is the viscosity fluid, L is the needle length, r_b is the cartridge inner radius, r_n is the needle inner diameter and V is the velocity of injection.

$$F_h = \left(\frac{8\pi\eta L r_b^4}{r_n^4} \right) V \quad (G-2)$$

The cartridges examined through this investigation are designed with a spec to be able to empty their contents in span of 8-40 seconds. Knowing the geometry of the cartridge, this spec provides the lower and upper bounds of injection velocity, 68.1 - 340.5 mm/min. Using Equation G-2, the force contribution from the hydrodynamic effects through a 31G needle range from 6.57 - 32.83N. Because force is directly proportional to velocity, the higher force is associated with the fastest injection time of 8 seconds.

Friction forces have been calculated throughout this investigation by simulating injection without Insulin or a needle. Friction forces are also proportional to velocity, however, the precise mathematical relationship is less clear. Under the lowest force conditions (low velocity) friction forces for production siliconized cartridges of up to 7.5N were observed for injection speeds of 50mm/min.

Comparing hydrodynamic and friction force magnitudes, it becomes clear that at lower injection velocities the friction component can make up more than half the total force. It is for this reason and these scenarios that friction forces are critical to ensuring consistent and reliable device performance. The figure below shows the force profile provided by a torsion spring used to drive injection. The largest risk of stalling, when friction and hydrodynamic force become greater than the spring force, is at the end of dose when the spring is more relaxed and exerts its lowest force. This further demonstrates the need to control friction force by reducing variability.

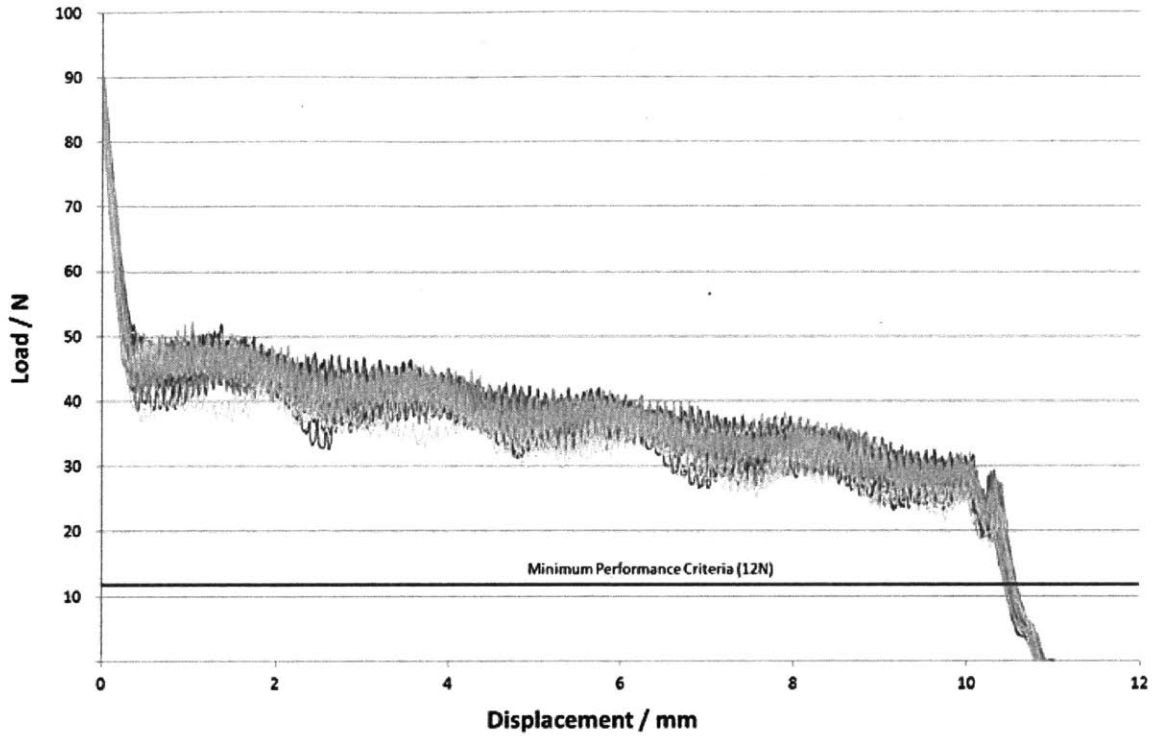

Figure: 3D Pen Spring Force Profile

Material Properties

Friction properties vary depending on material, environment and application. Dry friction and wet (or lubricated) friction behave in very different ways and are characterized by different equations and relationships. The Stribeck diagram introduced in Chapter 3 is presented again here for reference and provides a framework to describe what type of lubrication exists by evaluating material properties.

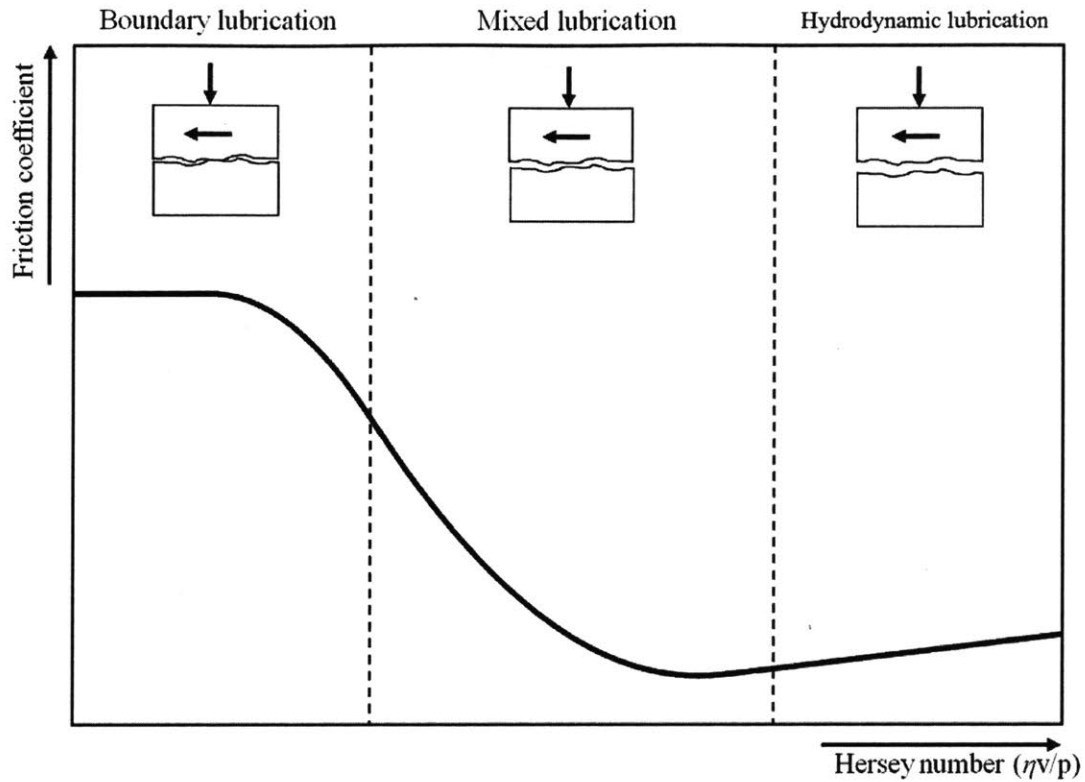

Figure: Stribeck Diagram [21]

These different lubrication regimes operate differently and it is valuable to know which regime is active as the rubber stopper glides through the siliconized cartridge. The physical factor that impacts what lubrication regime can be described by λ , the ratio of lubricant film thickness to the combined surface roughness of materials, where λ is presented in the Table below.

Table: Lubrication Regime

Lubrication regime	Ratio of lubricant film thickness to the combined surface roughness (λ)
Boundary	$\lambda < 1$
Mixed	$1 < \lambda < 5$
Elastohydrodynamic	$3 < \lambda < 10$
Hydrodynamic	$5 < \lambda$

To quantify the lubrication regime of this application, surface roughness measurements were collected for glass and rubber stopper samples. With surface roughness measurements, Equation G-3 can be used to determine the lubrication regime. In Equation G-3, h_{min} is the minimum lubrication thickness layer present between the two interacting materials and R_q are the roughness values of glass and rubber described by Equation G-4.

$$\lambda = \frac{h_{min}}{\sqrt{R_{q,glass}^2 + R_{q,rubber}^2}} \quad (G-3)$$

$$R_q = \sqrt{\frac{1}{n} \sum_{i=1}^n y_i^2} \quad (G-4)$$

Equation G-4 can be rearranged to solve for the minimum lubrication needed for the application to exist in a given lubrication regime.

$$h_{min} = \lambda * \sqrt{R_{q,glass}^2 + R_{q,rubber}^2} \quad (G-5)$$

Surface roughness values for glass and rubber were calculated used atomic force microscopy and white light interferometry respectively. The Figures below shows surface roughness for glass and rubber followed by calculated values for surface roughness (R_q). The average R_q for glass and rubber are 1.075 and 1385 nm respectively. What becomes immediately clear is the difference in magnitude of the surface roughness. Virtually all of the combined surface roughness comes from the rubber stopper.

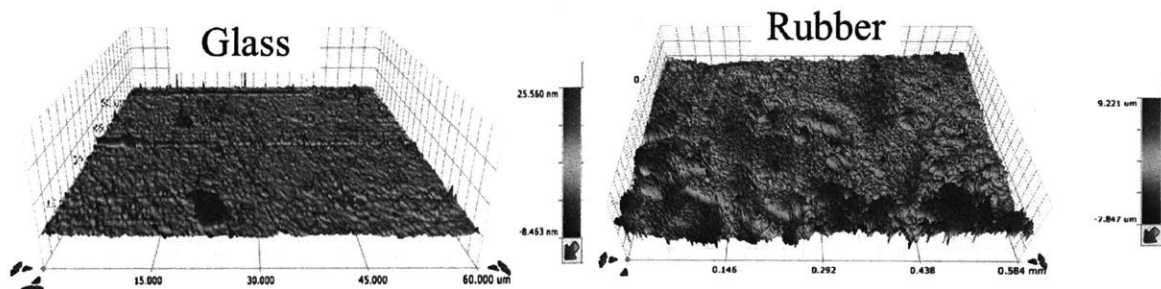

Figure: Surface Roughness

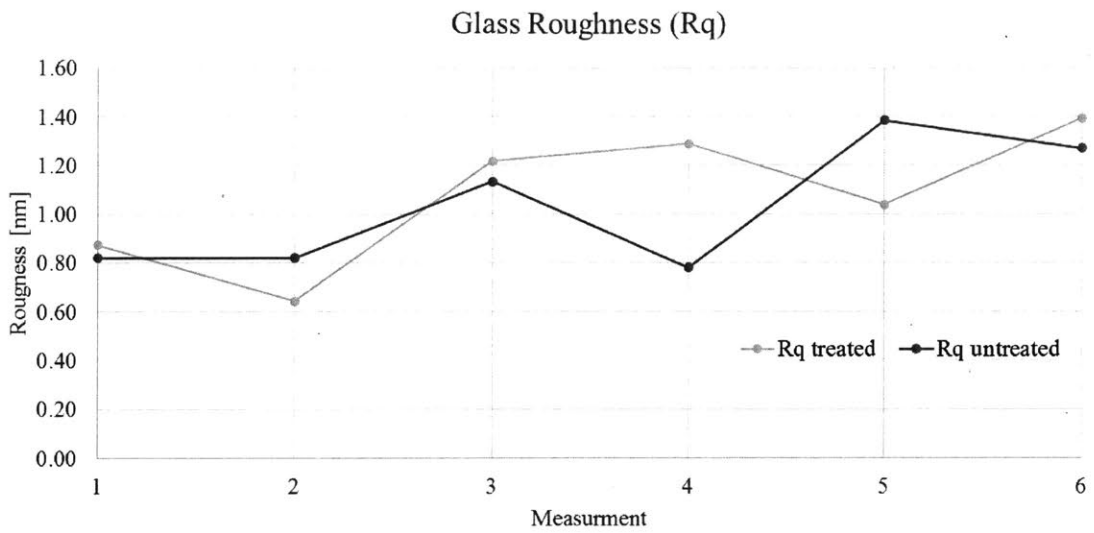

Figure: Rq for Glass Sample

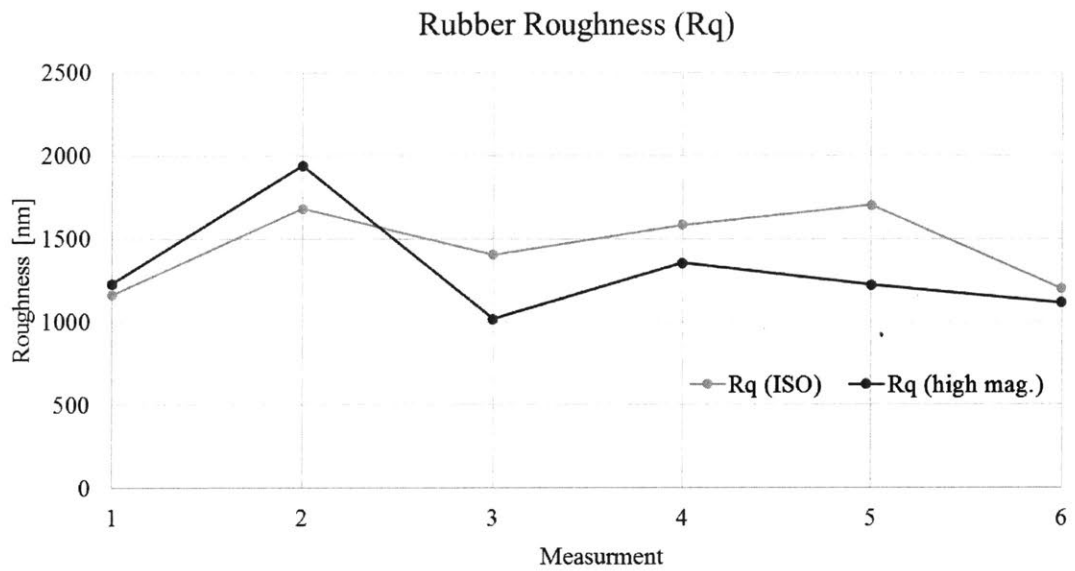

Figure: Rq for Rubber Sample

Expected Friction and Lubrication Properties

Using the surface roughness values measured for glass and rubber, Equation G-5 is used to provide the following analysis. The table below describes what silicone thickness would be required to move from one lubrication regime to another.

Table: Operating Lubrication Regime

Lubrication Regime	Parameter	Si thickness Layer [nm]
Hydrodynamic	$\Lambda > 5$	6921 (minimum)
Elastohydrodynamic	$\Lambda > 3$	4153 (minimum)
Mixed or Partial	$\Lambda > 1$	1384 (minimum)
Boundary	$\Lambda < 1$	< 1384

All of the data collected using the rap.ID layer explorer shows that silicone thickness is on the order of 100nm. This is an entire magnitude below what is required to enter mixed or partial lubrication. One source of uncertainty that is not accounted for in this analysis is the silicone oil that is present on the rubber stopper. The rubber stoppers are siliconized by the supplier prior to assembling them into the glass cartridge. This adds to the lubrication thickness and is known to be a non-zero number, but its value is unknown. However, assuming the silicone layer thickness on the rubber stopper is not significantly more than what is present on the glass surface, this results informs that lubrication for this application is taking place well within the boundary regime.

It would take significantly more silicone emulsion to move into mixed or partial lubrication. Alternatively, decreasing the surface roughness of rubber through processing could also have this effect. This would have the effect of lowering overall friction during operations, but there are risks associate with this including silicon-Insulin interactions and potential squeeze out of Insulin at the back of the cartridge.

This analysis suggests that rubber is coming into direct contact with the glass (or the cross-linked silicone) so the governing friction forces are most likely described by Equation G-6, which was presented earlier in Chapter 3.

$$F_{friction} = T_c A_{real} \quad (G-6)$$

where T_c is yield stress during shear and A_{real} is the real contact area. Opportunities to influence friction rely on improving consistency in the real area of contact between rubber and glass. This analysis scratches the surface of the theoretical and fundamental phenomenon governing this application and there is significant opportunity to take this analysis further to better understand the underlying mechanics governing the process.