

Design of an Ultraportable Surgical Enclosure for Low Resource Environments

by

Sally A. Miller

S.B. Mechanical Engineering
Massachusetts Institute of Technology (2016)

Submitted to the Department of Mechanical Engineering
in partial fulfillment of the requirements for the degree of

Master of Science in Mechanical Engineering

at the

MASSACHUSETTS INSTITUTE OF TECHNOLOGY

February 2018

© 2018 Massachusetts Institute of Technology. All rights reserved

Signature redacted

Signature of Author.....

.....
Department of Mechanical Engineering
January 15, 2018

Signature redacted

Certified by

.....
Daniel Frey
Professor of Mechanical Engineering
Thesis Supervisor

Signature redacted

Accepted by

.....
Rohan Abeyaratne
Professor of Mechanical Engineering
Chairman, Department Committee on Graduate Theses

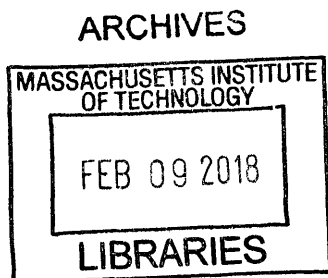

Design of an Ultraportable Surgical Enclosure for Low Resource Environments

by

Sally A. Miller

Submitted to the Department of Mechanical Engineering
on January 15, 2018 in partial fulfillment of the requirements
for the degree of Master of Science

Abstract

Access to surgical care for people in remote settings and/or developing countries is limited: 30% of the world's population receives 75% of major operations [1]. In developing countries, up to a third of patients acquire a surgical site infection (SSI), which is nine times more likely than in developed countries [2]. An estimated 85,500 cases of HIV and hepatitis are contracted by obstetrical/gynecological providers every year, and 90% of those cases are the result of treating patients living in poverty. SurgiBox aims to address these issues by providing a portable, sterile operating environment for use in austere settings. Not only are patients protected from environmental hazards through the use of SurgiBox, but medical personnel are also shielded from patient fluids, blood, and aerosols.

SurgiBox consists of a clear, disposable plastic enclosure that is adhered to the patient's surgical site and inflated with filtered air. Long gloves, similar those used in a glovebox, are integrated into the enclosure and used by the medical personnel to perform the surgery. Surgical instruments are sterilized before the surgery and are placed inside the enclosure prior to the procedure, but materials, or even a baby in the case of a cesarean section, can be passed in or out of the sterile field during the procedure through a resealable port. Particle count testing inside the enclosure shows that particle counts could be maintained at less than 25% of operating room standards for particles greater than 0.5 microns (OR standard: less than 83,000 particles/m³) and 0.3 microns (OR standard: less than 1,000,000 particles/m³).

Thesis Supervisor: Daniel Frey
Title: Professor of Mechanical Engineering

Acknowledgements

I would like to acknowledge several people who have been influential in my life over the last few years and helped me succeed with my masters degree.

The SurgiBox team, of course, has been hugely helpful. Dr. Debbie Teodorescu, the woman behind the vision, thanks for sharing your project with me! You are so dedicated to your work—I admire your creativity, hard-working attitude, and willingness to always put SurgiBox first. And to everyone else on the team who has helped me along the way: Rob, Keith, Mike, Jess, Amna, Annie, Stephen, and Sashi. It's been a joy to work with you and get to know you.

Thanks Dr. Stephen Odom and Dr. David King for providing valuable feedback throughout the design process! Hopefully soon you'll be able to perform procedures in low-resource settings more safely with the help of SurgiBox!

Thanks, Dan, for being a supportive advisor who has let me direct my own path during grad school. I always love hearing about your creative projects and new ideas.

My friends have been there to both support me in my work when I needed it, or provide distractions and adventures in the mountains when that was what was needed! Leigh Ann, Hilary, Julia, Neil, Chris, to name a few.

To my family, thanks for supporting me throughout my entire time at MIT, from a freshman back in 2012 until now. Look how far I've come! Despite being across the country, I appreciate you always welcoming me back with open arms (and I promise to return for good soon!).

Contents

| | |
|--------------------------------------------------------------|----|
| Abstract | 3 |
| Acknowledgements..... | 5 |
| 1 Background..... | 12 |
| 2 Literature Review..... | 14 |
| 2.1 Better Access to Safe Surgery is a Global Need..... | 14 |
| 2.2 Surgical Site Infections..... | 16 |
| 2.3 Operating Theaters in Developed Countries..... | 17 |
| 2.4 Operating Theaters in Developing Countries..... | 18 |
| 2.5 Case Study of Surgical Care in Uganda..... | 18 |
| 2.6 Attempts to Improve Surgical Care in LMIC Countries..... | 19 |
| 3 Motivation..... | 20 |
| 3.1 Potential Users..... | 20 |
| 4 Prior Art..... | 22 |
| 4.1 Patents..... | 22 |
| 5 Description of Original SurgiBox Design..... | 23 |
| 5.1 Patient-SurgiBox Interface..... | 24 |
| 5.2 SurgiBox Frame..... | 25 |
| 5.3..... | 25 |
| 5.4 Surgical Tray Support..... | 25 |
| 5.5 Environmental controls..... | 26 |
| 5.6 Workflow..... | 26 |
| 5.7 Takeaways..... | 27 |
| 5.7.1 Enclosure..... | 27 |
| 5.7.2 Frame..... | 28 |
| 5.7.3 Environmental System..... | 29 |
| 6 Functional requirements..... | 29 |
| 6.1 User interface..... | 30 |
| 6.2 Patient interface..... | 30 |
| 6.3 Setup..... | 30 |
| 6.4 Sterility..... | 31 |

| | | |
|--------|---------------------------------------|----|
| 6.5 | Cost..... | 31 |
| 6.6 | Manufacturability | 31 |
| 6.7 | Portability..... | 31 |
| 6.8 | Robustness | 31 |
| 7 | Final Design..... | 32 |
| 7.1 | Patient-SurgiBox Interface..... | 33 |
| 7.2 | Frame..... | 37 |
| 7.3 | Tethers | 40 |
| 7.4 | Enclosure..... | 34 |
| 7.5 | Environmental System..... | 41 |
| 8 | Surgical Tray Support | 44 |
| 8.1 | Sleeves..... | 45 |
| 8.2 | Workflow..... | 45 |
| 9 | Prototyping..... | 46 |
| 9.1 | Fabrication Techniques..... | 47 |
| 9.1.1 | Sewing..... | 47 |
| 9.1.2 | Hot Glue | 48 |
| 9.1.3 | Adhesives | 48 |
| 9.1.4 | Heat Sealing..... | 48 |
| 9.1.5 | Jigs..... | 49 |
| 9.2 | Alternate Port Ideas..... | 49 |
| 9.2.1 | Plastic Zippers | 49 |
| 9.2.2 | Pressurized Tubes | 49 |
| 9.2.3 | Velcro..... | 50 |
| 9.3 | Development of Patient Interface..... | 50 |
| 9.4 | Testing the Inflatable Design | 51 |
| 10 | Testing and Validation..... | 53 |
| 10.1 | User Testing | 53 |
| 10.2 | Environmental Testing..... | 54 |
| | Air quality testing..... | 54 |
| 10.2.1 | Anti-Backflow Testing..... | 56 |
| 11 | Future Work..... | 56 |
| 11.1 | Lighting..... | 56 |

| | | |
|------|------------------------|----|
| 12 | References | 59 |
| 13 | Appendix..... | 61 |
| 13.1 | Airflow algorithm..... | 61 |

List of Figures

| | |
|-----------------------------------------------------------------------------------------------------------------------------------------|----|
| Figure 1 Estimated number of deaths per year that could be prevented if basic surgical care could be provided in LMICs [6] | 15 |
| Figure 2 Patent 5316541..... | 22 |
| Figure 3 Original SurgiBox enclosure with patient's entire torso enclosed | 24 |
| Figure 4 Model of original SurgiBox design, showing PVC frame, arm ports, surgical tray and enclosure..... | 25 |
| Figure 5 Top view of SurgiBox in use | 32 |
| Figure 6 Side view of SurgiBox..... | 33 |
| Figure 7 Top of enclosure made with vinyl and LDPE with airflow tube in the middle | 35 |
| Figure 8 Inflated enclosure inside pentagonal frame (top) and deflated frame supported by frame and tethers (bottom)..... | 39 |
| Figure 9 Inflated enclosure within pentagonal frame | 40 |
| Figure 10 Patent drawing of mylar balloon inflation mechanism [25] | 42 |
| Figure 11 Schematic of airflow from filter to surgical site | 44 |
| Figure 12 Diagram of air control system | 44 |
| Figure 13 Demonstrating a first prototype of an inflated enclosure. Method of fabrication: sewing | 47 |
| Figure 14 Testing an inflated design with SurgiBox team member Rob Smalley | 52 |
| Figure 15 User testing to ensure visual clarity is acceptable | 54 |
| Figure 16 Particle testing for particles greater than 0.5 microns..... | 55 |
| Figure 17 Particle testing for particles greater than 0.3 microns..... | 56 |
| Figure 18 Operating room in Cameroon, providing inspiration for SurgiBox design decisions ... | 57 |

1 Background

The sterile field is the area surrounding the incision insertion point of any instruments into the body, its bottom boundary generally established by sterile drapes. All equipment in the sterile field must be sterilized or covered in sterile drapes. All personnel operating within the sterile field should wear sterile (i.e. contains no living microorganisms) attire [3].

Throughout a surgical procedure, the biggest defense against surgical site infections is a sterile field. There are guidelines for how to create and maintain the sterile field, starting with constant communication among all surgical team members. When creating and maintaining a sterile field, communication and behavior are the primary defenses against a breach. The Association of Surgical Technologists recommends eight Standards of Practice to ensure that this is successful. The following is an outline of the standards:

1. To provide for a safe and uneventful surgical procedure, the Certified Surgical Technologist (CST) should have all the necessary instruments, supplies, and equipment needed to prepare the sterile field for the surgical procedure.
2. The OR furniture and equipment should be grouped and positioned prior to opening the sterile items.
3. Aseptic technique must be strictly adhered to by the surgical team members when opening sterile instrument sets, packages and peel packs.
4. Traffic in and out of the OR should be monitored and controlled when the surgical team begins to open sterile items.

5. Sterile supplies should be opened as close to the time of surgery as possible and for one surgery only.
6. To contribute to the efficiency of surgical patient care the CST in the first scrub role should implement the principles of economy of motion when completing the setup of the sterile field.
7. To contribute to the efficiency of surgical patient care the CST in the first scrub role should establish a routine for setting up the backtable and Mayo stand. While set ups will vary according to surgical specialty, procedure and facility policy, there are principles that can be applied to all backtable and Mayo stand set ups.
8. The electrosurgery active electrode handpiece should be controlled when not in use to prevent inadvertent activation in order to avoid burns to the patient and sterile surgical team members, and ignition or puncture of the drapes [4].

All of these standards guide the behavioral approach necessary to keep a sterile operating environment and manage surgical site infections. As a result, all of these best practices should either be directly applicable to a product designed to improve the surgical field, or they should have a close equivalent. A product to fit this space needs to improve aspects of maintaining the sterile field without compromising others.

While behavior is an important part of maintaining any sterile field, the operating theater quality itself is vital. Without the ability to filter air and keep contaminants out of the surgical site, the previous guidelines are not as effective. Surgical site infection rate depends highly on the ventilation systems inside operating systems. In an evaluation of 5,800 surgical operations

for total joint replacements, the SSI rate fell from 7% to 0.5% when unidirectional airflow was introduced. There was a high number of hourly air exchanges, and surgical staff wore suits that covered their entire bodies [5]. This demonstrates that the air patterns inside even state of the art operating theaters have a high impact on the sterility achieved.

In order to create and maintain a sterile field to minimize the SSI rate, both behavior throughout the procedure as well as environmental control is important. SurgiBox aims to bring this environmental control to low resource settings, where expensive airflow systems are not affordable or feasible.

2 Literature Review

2.1 Better Access to Safe Surgery is a Global Need

With the poorest third of the world's population receiving only 3.5% of all surgical procedures [6], the need for improved global surgical care is undeniable. In the words of Dr. Jim Yong Kim, president of the World Bank, "surgery is an indivisible, indispensable part of health care" [7].

Many conditions, such as appendicitis, are only treatable through surgical intervention.

However, five billion people lack access to safe and affordable surgical care when needed, the majority of whom live in low- and middle-income countries (LMICs), or live in the poorest wealth quintiles of any country [7]. In an effort to make surgical care more equitably distributed, the World Bank developed Global Surgery 2030, which aims to provide 80% coverage of essential surgical and anesthesia services by 2030. According to the World Bank,

143 million additional surgeries need to be performed each year to meet the demand, and the highest need is in the poorest countries [8].

| Surgical condition | | Eastern Europe and Central Asia | Sub-Saharan Africa | Middle East and North Africa | South Asia | East Asia and Pacific | Latin America and the Caribbean | LMIC total | Major category totals (percent) |
|--------------------|---------------------------------------|---------------------------------|--------------------|------------------------------|------------|-----------------------|---------------------------------|------------|---------------------------------|
| Digestive diseases | Appendicitis | 1,773 | 14,248 | 1,035 | 1,712 | 3,905 | 3,614 | 26,286 | 145,292 (9.0) |
| | Gall bladder and bile duct disease | 3,672 | 9,123 | 1,950 | 2,087 | 21,605 | 9,477 | 47,914 | |
| | Hernia | 3,810 | 816 | 0 | 4,459 | 1,279 | 3,700 | 14,065 | |
| | Paralytic ileus and bowel obstruction | 938 | 17,637 | 4,622 | 23,360 | 4,525 | 5,945 | 57,027 | |
| Maternal-neonatal | Maternal hemorrhage | 63 | 10,228 | 703 | 6,147 | 2,424 | 478 | 20,042 | 233,658 (14.4) |
| | Obstructed labor | 8 | 2,248 | 59 | 8,284 | 255 | 28 | 10,882 | |
| | Abortion | 333 | 16,756 | 364 | 15,179 | 3,440 | 862 | 36,935 | |
| | Neonatal encephalopathy | 1,475 | 62,271 | 2,477 | 91,286 | 5,871 | 2,420 | 165,800 | |

Figure 1 Estimated number of deaths per year that could be prevented if basic surgical care could be provided in LMICs [6]

As seen in the Figure 1, access to surgery in LMIC countries is essential, especially for digestive diseases and maternal conditions.

An estimated 4664 inpatient surgical procedures per 100,000 people, or 321.5 million procedures globally, were needed in 2010. The types of surgeries varied greatly across the world; for example, surgical procedures addressing infectious and parasitic diseases accounted for 0.32% of procedures in Western Europe but 35.3% of procedures in sub-Saharan Africa. In sub-Saharan Africa, 20.4% of procedures were for maternal conditions. Understanding the variability in need around the world is vital when strategizing solutions to improve surgical care [9].

In “Training to Serve Unmet Surgical Needs Worldwide” from the Journal of the American College of Surgeons in October 2001, Robert Blanchard, MD, argues that surgeons trained in

the developing world need to have a very broad skillset, and that pursuing advanced technologies and specialized procedures should not be focused on as long as the demand for general surgeries persists. The top priority in developing countries should be improving access to the most common surgical illnesses, since access to surgical intervention for even routine surgeries is limited [10]. SurgiBox is designed to be used with the most common abdominal surgeries, and will thus improve care for the much-needed general surgeries.

While SurgiBox will not increase the number of doctors trained to perform the surgeries required to address the global need to increase surgeries, it will improve safe surgery in rural clinics or hospitals with inadequate operating rooms.

2.2 Surgical Site Infections

The biggest problem that SurgiBox is designed to address is the high rate of surgical site infections in developing countries. An SSI is an infection occurring up to 30 days after surgery that affects either the incision or the deep tissue at the operation site. The most common pathogens involved in SSIs are *Staphylococcus aureus*, coagulase-negative staphylococci, *Enterococcus spp.*, and *Escherichia coli*. If a surgical site is contaminated with greater than 100,000 microorganisms per gram of tissue, the likelihood of an SSI increases [11]. Acquiring an SSI means spending an average of an extra 7-10 additional days in the hospital and an increased chance of death [5]. SSIs affect up to a third of all post-operative patients in developing countries, and leading causes of the infections include inadequate hygienic conditions and waste disposal; poor knowledge and application of basic infection control measures; and insufficient application of standard and isolation precautions.

The CDC has set forth infection prevention guidelines to prevent SSIs. These include cleaning hands and arms up to the elbows with an antiseptic agent prior to the surgery, wearing hair covers, masks, gowns, and gloves, giving antibiotics prior to surgery and cleaning the surgical site [12].

With lower surgical site infection rates with SurgiBox, doctors will be able to focus less time on treating infections and more time operating on more patients

2.3 Operating Theaters in Developed Countries

There are a number of operating room characteristics that contribute to cleaner operating rooms and fewer surgical site infections. SurgiBox aims to shrink the sterile field necessary during a surgery down from the size of the operating room to the size of the patient, so operating room guidelines are taken into consideration in the design of SurgiBox to create a miniaturized sterile surgical environment. All surfaces in operating rooms should be smooth and compatible with chemical and physical cleaning agents [5]. Also important in the prevention of SSIs is ventilation during procedures. Dust particles, textile fibers, skin particles, and respiratory aerosols are present during surgeries, so an effective airflow system is essential in reducing airborne bacteria [13]. HVAC systems control the temperature, humidity, and air currents in the room. The air in operating theaters is slightly pressurized compared to nearby rooms, which prevents air from moving from less to more sterile environments [14]. The CDC also recommends exchanging the air in operating rooms at least fifteen times per hour, and three of those exchanges should be fresh air [15]. Turbulent airflow, which controls contamination through dilution and is common in many operating rooms worldwide, actually

17

speeds up microbial dispersion [5]. However, much of the contamination present is from the surgical staff themselves (e.g. skin cells), which SurgiBox will eliminate.

2.4 Operating Theaters in Developing Countries

Even when surgeries are performed in hospitals in developing countries, the conditions in which procedures are performed are often unacceptable. Dr. Stephen Odom, MD, trauma surgeon at Beth Israel Deaconess Medical Center, has traveled to Haiti, Malaysia, and many countries in Africa to perform surgeries, and explained that in many cases, lighting is poor, windows are open, and dust and insects end up in the surgical site [16]. While workflow before, during, and after surgeries worldwide is fairly standardized, the infrastructure to support these surgeries varies greatly across the globe.

2.5 Case Study of Surgical Care in Uganda

To get an idea of the surgical care available in one African country, provided are some key insights from a 2012 survey of surgical and anesthesia capacity in Uganda's public hospitals. Researchers found that there were only 328 formally trained surgeons in a country of over 32 million people. Patients had to travel an average of 33 km to reach their nearest hospital, and all hospitals surveyed reported frequent power outages. All hospitals had at least one working autoclave and performed surface disinfection of operating theaters [17]. SurgiBox could be used in these hospitals to work alongside existing infrastructure while improving sterility. These statistics from Uganda highlight the need for improved surgical care and indicate some important functional requirements, namely that a device should not rely on constant electricity

and a portable device could cut down on the travel distances currently necessary. Additionally, although SurgiBox cannot address the fact that there are not enough surgeons to meet the needs of the country, SurgiBox does have potential to improve care for people who cannot travel to a hospital.

2.6 Attempts to Improve Surgical Care in LMIC Countries

Attempts have been made to improve surgical care in areas with insufficient access to hospitals.

A notable example of a technology that has brought 7000 operations to people in remote areas is a converted delivery truck in Ecuador, a project spearheaded by Edgar Rodas, the former Ecuadorian minister of health. The truck has an operating theater in the back and has been used to perform surgeries all over the country. The cost of the truck was about \$75,000, and the average cost of a surgery that would cost \$10,000 in the United States is less than \$100 [18]. A similar project is CompactOR, a portable operating theater for use in rural area that can be transported by car. CompactOR is equipped with the tools necessary to perform a wide range of surgeries, from appendectomies to hysterectomies and heart surgeries [19].

In an attempt to improve surgeries with a behavioral approach, the WHO published “Safe Surgery Saves Lives,” which sets the challenge to improve surgical care through the improvements of surgical site prevention, safe anesthesia, safe surgical teams, and the measurement of surgical services. In order to address these issues, the WHO published a safety checklist to ensure that proper procedures are followed each time [1].

SurgiBox fits into a high-need market with few products designed to lower surgical site infections in low-resource settings. Paired with improved sterility thanks to dissemination of things like the WHO's safety checklist, SurgiBox will be able to improve safe surgery around the globe.

3 Motivation

As described in the previous section, SurgiBox has the potential to have a big impact on improving safety during surgical procedures in low-resource settings.

3.1 Potential Users

Three main use cases for SurgiBox have been identified: developing countries, disaster relief, and the military. Each has a large potential market and a large user base, and ultimately, we would like to have an impact in all three segments.

Many developing countries have high rates of surgical site infections, even in operating rooms in hospitals. SurgiBox can have a large impact if it is used within operating rooms to improve the sterility and safety of the operation. Additionally, five billion people have inadequate or no access to surgical care [20]. SurgiBox can be used in rural clinics, temporary hospital tents, or even in a makeshift clinic. It can be used to expand the surgical capabilities of developing countries in a safe way.

Disaster relief is another high-impact possibility for SurgiBox. Units could be stored around the world in emergency caches, and used in compromised hospitals or temporary clinics. During

natural and man-made disasters, injury rates skyrocket, which adds to the unrelated surgical burden of routine surgeries.

The military is another promising market for SurgiBox, because of the high injury rates. From 2001 to 2006, soldiers in Iraq and Afghanistan over 7,000 injuries to extremities, 7% of which resulted in an amputation [21]. SurgiBox would allow time-sensitive operations to be performed in more remote settings, without the need to transport the patient to a facility capable of providing the necessary sterility. In some dire cases, the surgeries are performed in the field, and SurgiBox could be used to create a much safer environment for those procedures. The biggest concern with designing for a military application is how unpredictable the injuries are, and how many of them are often contaminated (as in most trauma injuries).

It is important to narrow down the scope of the problem and only address one market initially. Each market will have slightly different needs and limitations, and different distribution strategies, and if I tried to design a solution that would fit all, it would likely not be an adequate fit for market and be less likely to be successful. Additionally, if the market is initially narrow and slowly broadened, much will be learned along the way about what parts of the design work and which need to be improved, and those changes can be implemented much more easily if the market is small and well-defined.

Ultimately, the SurgiBox team chose to pursue developing countries as the first market. This was chosen partly because the project has been a part of D-Lab since its inception, meaning it has always been designed through a development lens. Additionally, it has gained the most publicity through various development channels and conferences. However, while developing

countries are the current focus of the SurgiBox team, depending on funding sources in the future, it may be shifted to another market segment.

4 Prior Art

4.1 Patents

There are a number of patents that similarly aim to shrink the sterile field during operations. However, the biggest difference between anything that has been patented and SurgiBox is the intended use: while the other devices were designed for use in modern operating rooms, SurgiBox is designed specifically to meet the needs of hospitals in developing countries. As a result, SurgiBox was designed with an added set of functional requirements pertaining to usability and cost.

US patent 5316541 comprises a transparent enclosure with integrated gloves that adheres to the patient's surgical site. It is intended to protect "medical personnel from being infected by the patient and the patient from being infected by the surgical environment." Additionally, it reduces sterilizing procedures and attendant costs required before and after a surgery is performed [22]. A notable difference between SurgiBox and this design is there is a support structure to support the tent. SurgiBox, on the other hand, simply uses positive pressure and a minima frame to provide its structure.

U.S. Patent May 21, 1994 Sheet 2 of 6 5,316,541

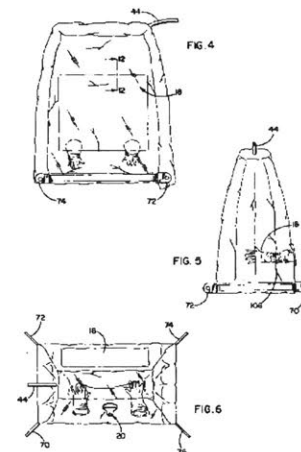

Figure 2 Patent 5316541

US patent 6199551 comprises an enclosure to isolate the patient's surgical site. A positive pressure is maintained to decrease blood loss during surgery. The increased pressure is intended to minimize the passage of blood through and out of damaged blood vessels [23].

Both of these patents can offer insight about how to create a positive pressure system that integrates with the patient's body. SurgiBox improves upon these ideas and is designed specifically for use in low-resource settings.

5 Description of Original SurgiBox Design

SurgiBox was first envisioned in 2010 by Dr. Debbie Teodorescu, a medical student at Harvard Medical School. She heard stories of operating rooms with inadequate facilities, leading to unsafe operating conditions and high SSI rates. She brainstormed ways to shrink the operating room down to the size of the patient to create an enclosure that was much more manageable to keep sterile. She iterated several times on her design, and in summer 2016, she asked Professor Dan Frey to join the team as advisor, and they also brought me on to redesign SurgiBox.

Essentially, the original SurgiBox was a rigid frame supporting a transparent plastic enclosure, which enclosed the patient's torso, and was filled with HEPA-filtered air to provide a sterile surgical environment while protecting medical providers from the patient's bodily fluids.

In order to provide context for the design changes that I made, the following is a detailed description of the previous iteration of the SurgiBox system.

5.1 Patient-SurgiBox Interface

A plastic enclosure fully contains the patient's torso, sealing around the patient's armpits and waist. It extends above the legs to provide a space for the surgical tray. The enclosure can be opened along one side to get the patient inside the system, after which it is wrapped around the body. Elastic at the two points at which the body interfaces with the enclosure can be tightened to create the seal.

The enclosure is made out of vinyl to provide users with the best visibility into the system. There are LDPE sleeves to provide access into the surgical space. At the end of the sleeves are thin, one-size-fits all gloves. Users place their hands in the gloves and don their own, tight fitting surgical gloves over the integrated gloves, which are thin enough that they do not interfere with dexterity when they are compressed by surgical gloves.

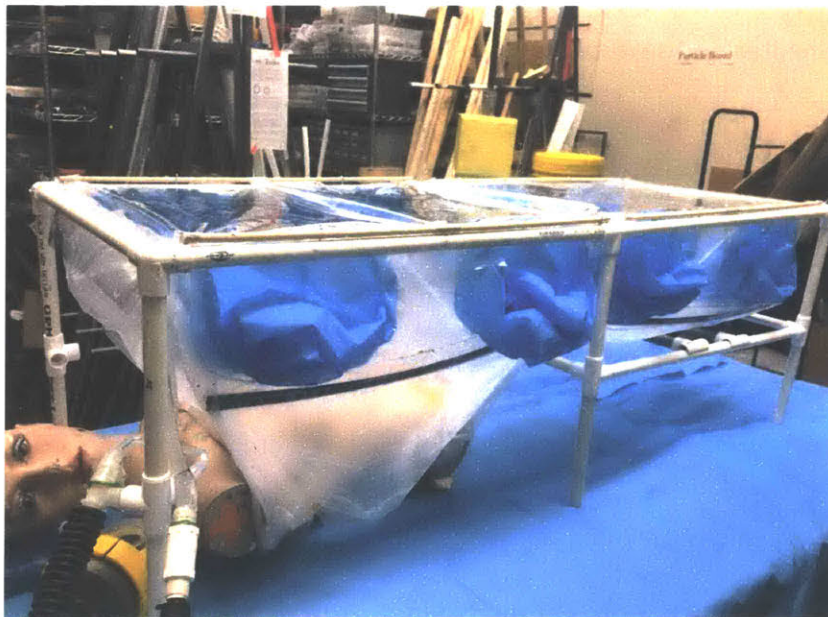

Figure 3 Original SurgiBox enclosure with patient's entire torso enclosed

Ports are integrated into the enclosure to allow materials to be passed into or out of it. There is an 18-inch wide port above each set of sleeves, and the ports are sealed with magnets.

The enclosure is supported by a frame (see description of frame below), and the vertical walls of the enclosure are made of loose plastic to allow for a wide range of motion.

5.2 SurgiBox Frame

The original SurgiBox has a rigid frame to hold the liner taut. This frame is made of several pieces of PVC pipe and connectors. The frame can be disassembled to be more portable. The frame is attached to the enclosure with clamps.

5.3 Surgical Tray Support

The surgical tray was supported by the frame over the patient's legs. Horizontal PVC pipes running parallel to the legs are dimensioned to support a tray. The tray would be inserted into the enclosure prior to the procedure.

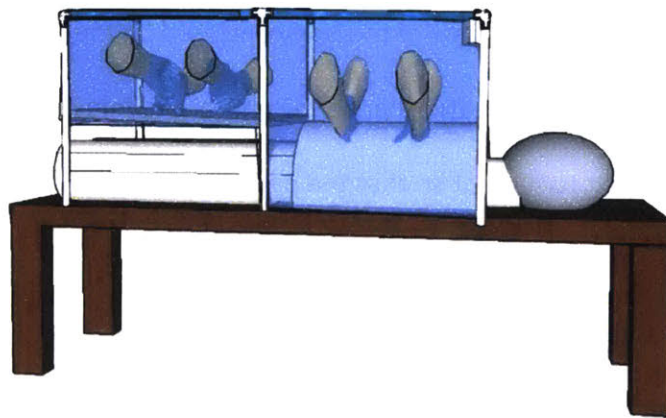

Figure 4 Model of original SurgiBox design, showing PVC frame, arm ports, surgical tray and enclosure

5.4 Environmental controls

An integral part of the current and past versions of SurgiBox is the environmental control system. In the previous version, the air filtration was a repurposed mask with integrated HEPA filter. The maximum airflow was 0.24 m³/min. The air entered the enclosure at the patient's head, and included a one-way valve to prevent backflow.

While the system would primarily operate on battery power, it was also equipped with a foot-operated bellows pump, so clean air could be pumped into the enclosure in case the primary pump or battery failed.

5.5 Workflow

The SurgiBox liner is packaged so that it is first unfolded beside the patient. The following is a description of the steps to prepare the patient for a procedure using the original SurgiBox design:

1. Clean entire torso (this is the part of the body enclosed by the SurgiBox and therefore should start clean to minimize the chance to surgical site infections).
2. Unroll enclosure next to patient so that the part that will be tucked under the patient is next to them.
3. Lift patient and slide bottom of enclosure under them.
4. Unroll remainder of enclosure and wrap around patient
5. Seal enclosure at along open edge
6. Tighten elastic at waist and armpits

7. Assemble frame
8. Place frame over patient
9. Attach enclosure to frame with supplied clamps
10. Attach environmental control system to port in enclosure
11. Begin running fan
12. After two minutes, begin procedure

5.6 Takeaways

Through setting up and taking down the original SurgiBox several times and interviewing the team, I identified several 'pain points' that should be fixed in future iterations.

5.6.1 Enclosure

First and foremost, the system was inflexible in the size of patient it could be used for. Both torso girth and length vary greatly among humans, meaning multiple versions of the enclosure would have to be produced to fit the spectrum of sizes. This adds complexity to manufacturing since multiple tooling variations need to be created. Additionally, in order to be well-stocked, a hospital or clinic would need enclosures of all sizes, meaning a large inventory, which is costly and inconvenient to store and transport. It would also likely result in the wrong size liner being used for a patient, either by accident or because the correct one was not available at the time of the procedure.

This system was also difficult for the patient to don. Because the liner wraps completely around the patient, the patient had to be rolled or lifted in order to get in the system. This would be

difficult with a large patient or a patient in a lot of pain. It also does not fit well with the current workflow before many procedures, meaning it would be more difficult to adopt the technology.

The enclosure is fully opened to get the patient inside the system, allowing contaminants to get inside the enclosure. These contaminants include skin (and other) cells or bacteria from the medical providers, dust from the environment, and any bacteria that may be on the surgical table.

Because the patient's entire torso is enclosed by SurgiBox, the entire torso must be cleaned, which may be difficult when time is tight before an emergency procedure or if the patient is particularly dirty. If the torso is inadequately prepared for the surgery, the SurgiBox would be less effective.

Another challenge introduced by this patient interface is it is optimized for abdominal and thoracic procedures, but cannot easily be used for other operations. Because of the proportions of the system, it would be difficult to create an adequate seal around a leg or arm, for example, to have a wider variety of procedures supported by SurgiBox.

5.6.2 Frame

While the frame could certainly be redesigned to be more intuitive and faster to set up, the concept of the frame itself poses some risks to the procedure, which led to its removal in the design of the new prototype.

First of all, the frame holds the enclosure rigidly, maintaining the volume inside the sterile area. This means that if the ports are opened or the enclosure is breached in some other way (for

example by a stray scalpel or manufacturing defect), the pressure inside will equalize to match the pressure of the environment, allowing diffusion into the system. This is a concern because it reduces the impact of SurgiBox. Additionally, it is difficult to recognize and solve the problem as there is no feedback that the system may be breached because the frame holds the liner in the same orientation no matter the pressure inside.

Because the enclosure is set up and attached to the frame before the environmental system is attached, the system is filled with potentially contaminated air. It takes about two minutes, as shown by testing, for diffusion to leave the inside of the enclosure acceptably clean, according to operating room standards.

The frame is slow and confusing to set up, and breaks down into several parts. It would be easy to lose a part or put it together incorrectly, and setting up the frame is a considerable fraction of the time to prepare the patient for surgery.

5.6.3 Environmental System

The maximum airflow from the fan used is 0.24 m³/min. If a port has to be opened during the procedure to pass something into or out of the enclosure, outside air will soon diffuse into the enclosure.

6 Functional requirements

When I joined the SurgiBox team, I spent a few months doing a literature review and interviews with past team members, as well as local doctors and medical students. Based on these interviews, I developed a list of functional requirements. This allowed me to take a step back

and look at the problem as a whole, and reassess how it could be solved. I could creatively come up with new solutions to fit the functional requirements, even if they did not look like the original SurgiBox design. The following functional requirements guided the redesign of SurgiBox.

6.1 User interface

| | |
|------------|--------------------------------------------------------------------------------------------------------------|
| Visibility | High visibility through the liner to allow unhindered ability to perform procedure |
| | Should account for humidity and splashing |
| | Material selection should prevent warping of view due to ripples |
| Ergonomic | Users should be able to perform standard procedures without drastic changes to workflow |
| | Users should have range of motion to accommodate all motions necessary, including passing tools and suturing |
| | Users can use their own fitted surgical gloves |
| Accessible | Four users can access the sterile field |
| | Materials/tools can be passed on/off sterile field |
| | Babies can be removed in the case of a cesarean section |

6.2 Patient interface

| | |
|----------|----------------------------------------------------------------|
| Flexible | Fits a wide range of patient sizes (ideally one-size-fits-all) |
| | Can be used on pregnant patients |
| Reliable | Seals reliably and intuitively around surgical site |

6.3 Setup

| | |
|-----------|-----------------------------------------------------------------------------------------------------------|
| Time | System can be set up in less than two minutes |
| Intuitive | Can be set up with minimal training |
| Flexible | Can be used in a variety of settings, including inside operating rooms, hospital tents, and rural clinics |

6.4 Sterility

| | |
|-------------------------------|-------------------------------------------------------------------------------------------------------------------------------|
| Provides Sterile Field | Provides an environment to safely perform abdominal procedures without exposing the surgical site to the outside environment. |
| | Sterile field is attained within two minutes of setting up SurgiBox |
| Maintainable | Sterility is maintained throughout operation |
| | Ports can be opened and closed without compromising sterility |
| Meets or Exceeds OR standards | In terms of surgical site infection rate and particle counts |

6.5 Cost

| | |
|-------------------------|-----------------------------------------------------------------------------------------------------|
| Affordable upfront cost | Environmental control system, tubing, and frame should be affordable by most clinics or NGOs |
| Low recurring costs | Liner cost should not exceed cost of drapes |
| Low energy budget | System should be able to operate on battery power if used in a location with unreliable electricity |

6.6 Manufacturability

| | |
|----------------|------------------------------------------|
| Reliable | Employ existing manufacturing techniques |
| Cost-effective | Use affordable, accessible materials |

6.7 Portability

| | |
|-------------|----------------------------------------------|
| Lightweight | Entire system can be transported by a person |
| Compact | Easily shippable and storable |
| | Person can carry enough for five surgeries |

6.8 Robustness

| | |
|------------|---------------------------------------------------------------------------|
| Repairable | Should be repairable in the field either with common tools or spare parts |
|------------|---------------------------------------------------------------------------|

| | |
|--------|------------------------------------------------------------------------|
| Robust | Should hold up to rough transport |
| | Reusable components should hold up for hundreds of uses |
| | Should not fail during a procedure with unexpected motions or movement |

7 Final Design

The final design was based on fulfilling all the functional requirements and solving the problems faced by the previous version of the prototype. The following section provides a detailed description of the most recent design for SurgiBox.

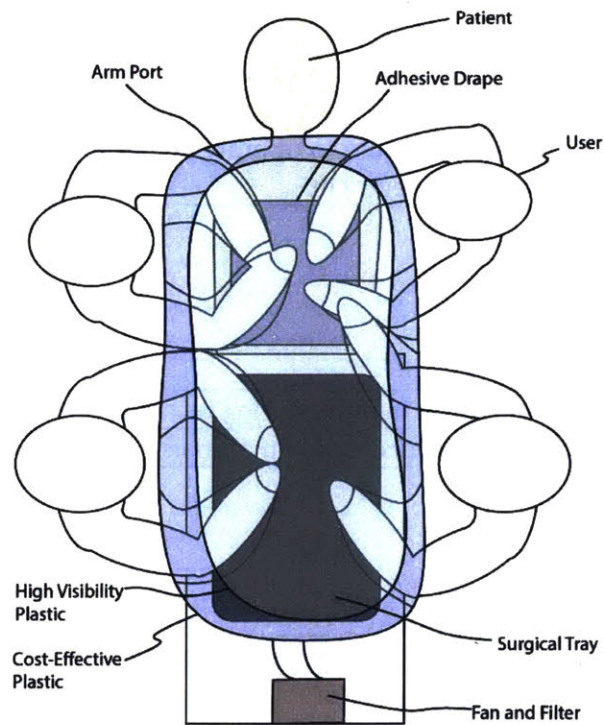
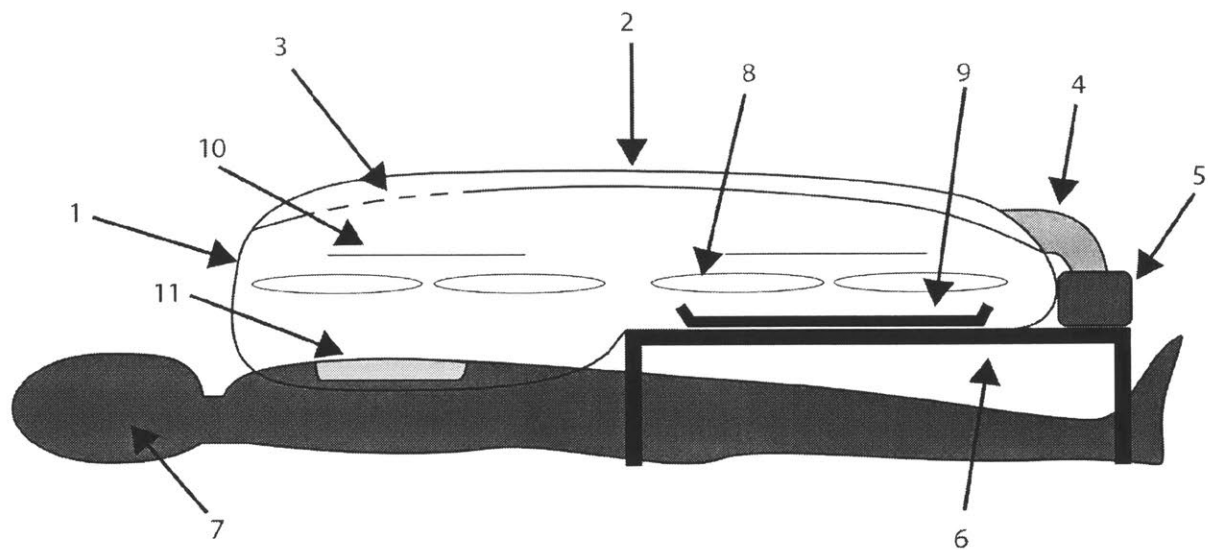

Figure 5 Top view of SurgiBox in use



- 1: Plastic enclosure
- 2: Overhead inflow tube
- 3: Directed airflow over surgical site
- 4: Flexible tubing
- 5: Fan and filter
- 6: Table
- 7: Patient
- 8: User sleeves
- 9: Surgical tray
- 10: Material port
- 11: Incise drape

Figure 6 Side view of SurgiBox

7.1 Patient-SurgiBox Interface

In order to tackle the problem of making SurgiBox compatible with patients of all sizes, the enclosure was redesigned so it no longer wraps around the patient's torso, as in the original design. Instead, the surgical enclosure now rests on top, meaning it does not have to be adjusted for the patient's size. An incise drape is integrated into the bottom of the enclosure.

The backing is peeled off the incise drape and it is placed on a patient's prepared torso, as shown in Figure 6.

An advantage of the incise drape is it can be used for a wide range of procedures. A large drape (about 12 inches by 18 inches) is incorporated in the liner, and this drape is adhered to the surgical site. As long as the incise drape is big enough to completely cover the incision, it does not matter if it is oversized; thus the enclosure can now be a 'one-size-fits-all' product, decreasing problems with manufacturing and storing inventory.

Another notable advantage of the incise drape is it will be destroyed after each procedure: it will have been cut through, and it will have lost its adhesion after being used on the patient. This makes it no longer usable for future procedures, which is advantageous because it is contaminated and could infect a future patient if it were reused. In low-resource settings, people are often very creative and resourceful, finding new uses for materials and parts that may be discarded elsewhere. While this is a good practice and leads to many cost savings in some cases, it could be disastrous for a product such as the SurgiBox enclosure, which could do the exact opposite of what it is intended for by causing more infections and an unsafe surgical environment.

7.2 Enclosure

In order to combat the problems posed by the frame, the frame was eliminated altogether: through using a more powerful fan to inflate the enclosure, a positive pressure can be maintained so that the frame can be eliminated—the liner is inflated.

The idea resembles a glovebag, which is a low-cost inflatable chamber with built-in gloves to create an isolated environment where access to a traditional glovebox is not possible. They can be used either to keep outside contaminants from a sample inside the glovebag, or to protect the user from a harmful sample. Glovebags generally have three different closure mechanisms: a zipper, tape, or removable clip [24].

Glovebags can guide the design for manufacturing of SurgiBox, but it has some key differences. While glove bags are generally made solely out of low-density polyethylene, this does not provide the visual clarity necessary for a surgery. As a result, SurgiBox is made with multiple types of plastic.



Figure 7 Top of enclosure made with vinyl and LDPE with airflow tube in the middle

The internal pressure to achieve optimal inflation was 1.08 atm. The pressure should be high enough so that the enclosure is inflated and the plastic is taut, thus providing adequate visual clarity for the users. However, if the pressure is too high, there is the risk of the ports opening unexpectedly.

The ports are designed with the users in mind, and many types and configurations were tested. The ports must allow for the easy insertion of the surgical tray and surgical tools prior to the procedure. Additionally, it's possible that materials will need to be moved in or out of the enclosure during the procedure.

There are a total of four ports in the enclosure, one over each set of sleeves. The ports over the sleeves of the user performing the operation (i.e. the sleeves over the incise drape) are 8 inches wide. Tools can be passed in and out during a procedure, and the airflow can be increased to accommodate for the breach, thus preventing the enclosure from collapsing and preventing external contaminants from getting into the system. There are two additional ports over the other two sets of sleeves. These ports are 18 inches long to accommodate a surgical tray being passed into the enclosure prior to the procedure or a baby being removed from the enclosure after a cesarean section.

Ultimately, magnets were chosen as the best mechanism for closing ports. They provide a good seal and they are self-aligning, so once a user begins to close the ports, they snap into place on their own. They can pop open if the pressure inside is too high, making it important to ensure that the internal pressure is at the appropriate level.

The major downside to using magnets is they are currently the most expensive component of the disposable liner. One possible way to design around this is if the magnets are reusable and can be slipped in and out of sleeves, which could be built into the liner.

7.3 Frame

A big breakthrough was the elimination of the bulky frame used to support the liner. SurgiBox needs to have positive pressure, just like in operating rooms, to prevent air from outside the system from entering the enclosure. In previous versions, the frame fully supported the liner, keeping its shape around the patient. However, the frame caused several problems:

- Conflicts with the users' field of view,
- Provides another point of failure
- Adds bulk to the system for transporting it
- Restricts the user's motions.

When I first introduced the incise drape into the design, I envisioned a frame that would need to be adjustable to some extent: the height would have to be adjusted to accommodate varying girths of patients. The distance between the top of the SurgiBox (sitting on top of the patient) and the top of the frame should be at approximately the same level. The length would likely have to be adjustable as well to accommodate different torso lengths.

When the design evolved to be inflatable instead of frame-supported, there were two obvious options: either completely eliminate the frame, or retain a back-up frame.

Initially, I was a very strong advocate for completely eliminating the frame. One advantage of the inflatable, positive pressure-supported frame was that if a port is opened or the enclosure is nicked, the enclosure begins to collapse, forcing the clean air out and preventing the potentially contaminated air outside from entering the enclosure. When the nick is patched or the port closed, the enclosure would immediately begin to reinflate. If a frame holds up the enclosure, an open port or nick could easily go unnoticed, and if the flow out is great enough, the positive pressure inside will not be maintained.

There are also some notable disadvantages of completely eliminating the frame. While increased airflow can prevent the enclosure from collapsing if a small port is opened, the enclosure will collapse if the large port needs to be opened. Luckily, this is not anticipated to be a likely event, but the large port would need to be used if, for example, an infant needs to be removed after a cesarean section.

Ultimately, I designed a minimal frame, which addresses some problems posed by a completely frameless design, without being bulky or compromising the sterile field but supporting the enclosure even in the case of a breach. This pentagonal frame was inspired by camping tents: poles under tension create a closed loop and are stiff due to the tension within them.

The frame is planar, so to prevent it from tipping over, it was designed so that it is attached to a flat, padded board that is slipped underneath the patient's back. Because the patient is lying down throughout the procedure, they prevent the frame from tipping. This also makes it easy to adjust the position of the frame relative to the liner.

The frame is collapsible, lightweight, and portable. Elastic runs through the aluminum poles, meaning when it is collapsed, all the parts are still attached to prevent parts from being lost. It can be used or not used according to the specific scenario and preferences of the users.

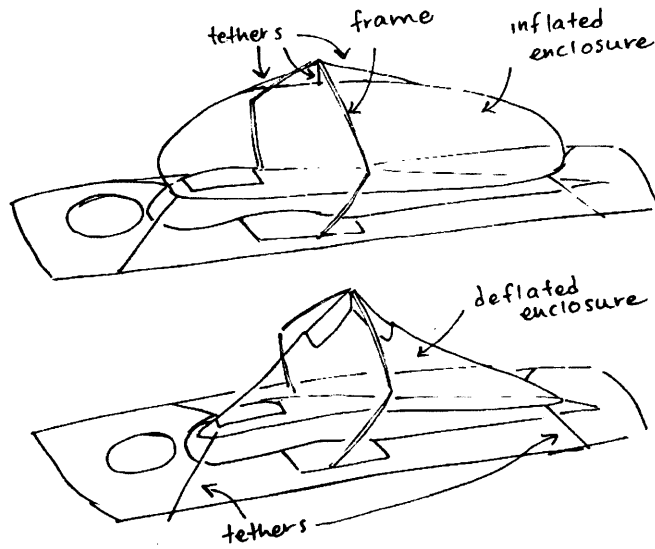

Figure 8 Inflated enclosure inside pentagonal frame (top) and deflated frame supported by frame and tethers (bottom)

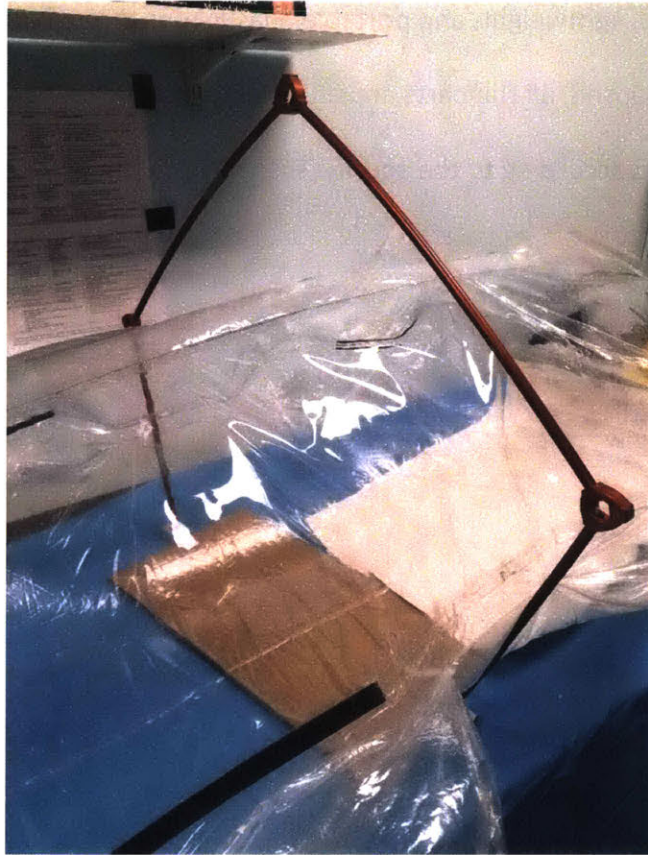

Figure 9 Inflated enclosure within pentagonal frame

7.4 Tethers

There are three tethers attached to the top of the SurgiBox enclosure which are tied to the frame. If the enclosure loses pressure, it will mostly collapse but be held up by the points at which the tethers attach, which is important because it suspends the top of the enclosure above the surgical site and the surgical tray. This prevents the top of the enclosure from interfering with or impeding the procedure, and also prevents it from getting punctured by tools.

Additionally, there are tethers on the bottom of the enclosure near the head and feet of the patient. These tethers ideally are tied to the surgical table to prevent the enclosure from rotating during use. They also help ensure that the incise drape will not peel up from the surgical site during the procedure. If the tethers cannot be tied to the table, they can alternately be tied under the patient.

7.5 Environmental System

One of the biggest challenges after turning to a higher airflow, inflatable version of SurgiBox was preventing backflow into the fan and filter. Backflow from the inside of the liner back into the fan and filter would mean contamination of the environmental system, and it would either need to undergo a thorough sterilization process or be disposed of.

One-way valves are generally expensive, especially at the flow rates and diameters needed for SurgiBox. As a result, other methods of preventing backflow were explored. The breakthrough came after studying the sealing mechanism of Mylar balloons.

Most Mylar balloons have very simple self-sealing valves for inflation. They consist of long flat plastic tubes made of two flat pieces of flexible plastic sealed at the edges. A nozzle is inserted into the end during inflation, forcing the end open. Since this tube is much longer than it is wide, it self-seals when the nozzle is removed because the tube is naturally in a flattened state, and since there is pressure on the outside of it, there is nothing to force it open to allow air to leak out.

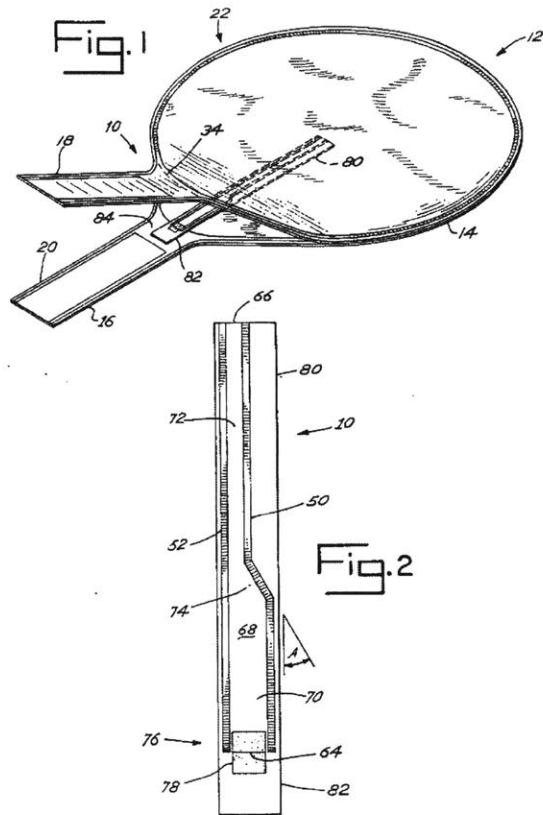
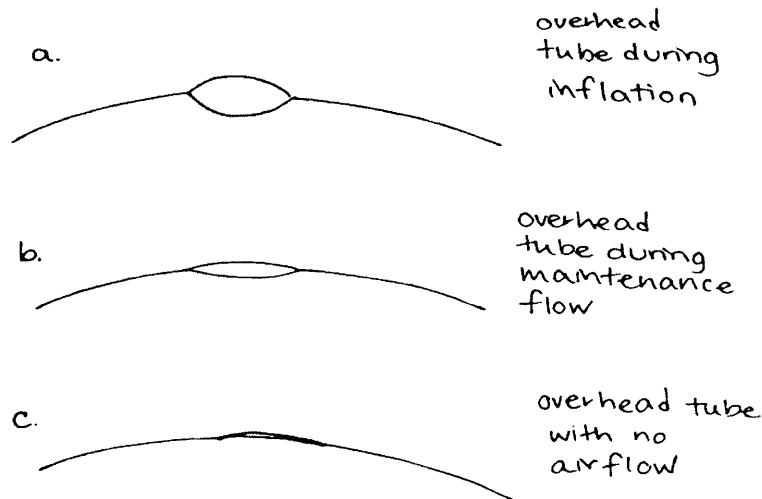

Figure 10 Patent drawing of mylar balloon inflation mechanism [25]

This concept was adapted to fit the needs of SurgiBox. A long overhead tube (flattened width of two inches) reaches from the fan to the far end of the liner and is integrated into the underside of the top of the enclosure. The tube has holes above the surgical site, thus blowing air straight from overhead onto the surgical side, similar to the air patterns inside conventional operating rooms.

During inflation, this overhead tube is expanded as filtered air is pushed through it. During maintenance flow, less air is flowing through the tube, and as a result it is partially collapsed. If the airflow is completely shut off, the overhead tube collapses, and thus prevents backflow.



The positioning of the holes was chosen such that there is equal airflow out of each hole. The holes vary in density at the end of this collapsible tube to create uniform airflow over the surgical site. The pressure inside the tube increases along the tube, reaching a maximum at its terminus (near the patient's head). As a result, the perforation density (or the size of the perforations themselves) must decrease along the tube to allow for a uniform flow rate.

The fan chosen which has the following specs has a maximum airflow of 200 CFM (5.6 m³/min).

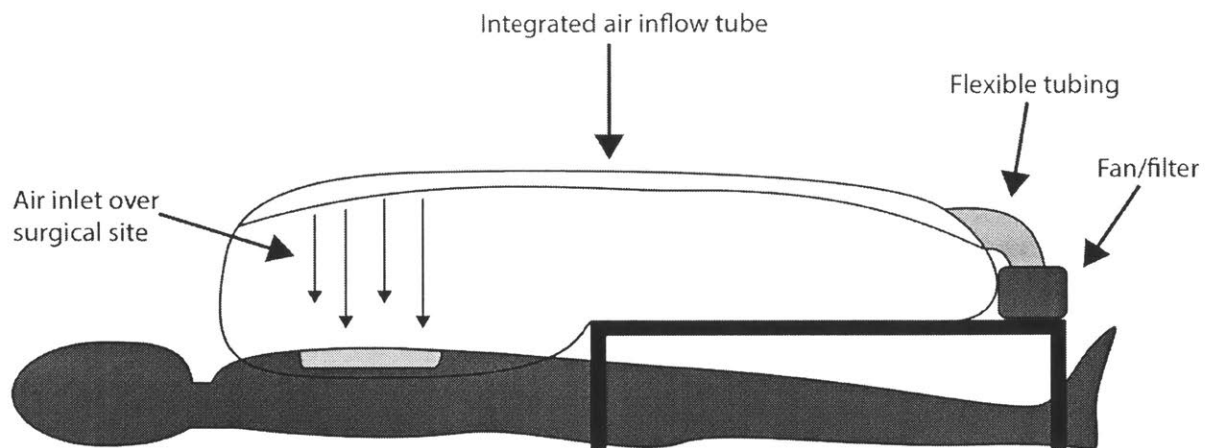

Figure 11 Schematic of airflow from filter to surgical site

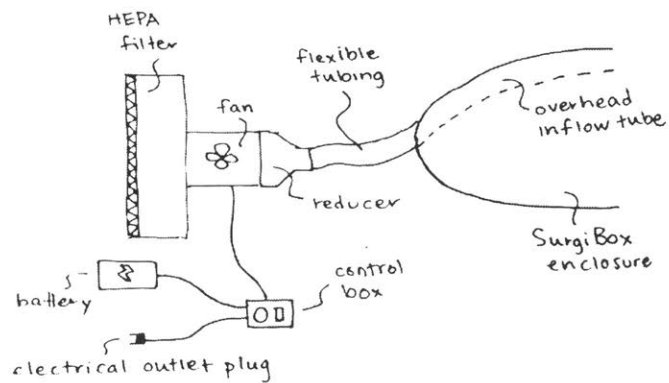

Figure 12 Diagram of air control system

7.6 Surgical Tray Support

Surgical trays ('Mayo trays') are nearly ubiquitous around the world as a means of providing easy access to tools. These trays are commonly on a table beside the operating table or on a stand that supports the tray over the patient's legs.

Because the tools for SurgiBox need to be inside the enclosure to prevent them from being contaminated, they need to be supported over the patient's legs. This could either be done with a supplied collapsible table or a Mayo stand. The table or stand would be on the outside of the enclosure, and the tray would be on the inside. One challenge of using a Mayo stand is the tray could be knocked off if the plastic liner in between the tray and the stand is jostled, but clamps could be used to prevent this from happening.

7.7 Sleeves

The sleeves self-seal when the enclosure is first inflated. The users place one pair of gloves each into the enclosure before the procedure when placing the surgical tray inside. They don a pair of gloves outside the enclosure, then reach their hands through the sleeves, and pull on the second pair of gloves, pulling the cuffs so they cover the sleeve, creating a seal.

Alternatively, there can be a design with very thin, large (one-size-fits-all) gloves attached to the end of the sleeves. This design was tested in previous versions of SurgiBox. While the gloves were thin enough that they did not bunch up and cause problems under the tight-fitting surgical gloves, they were so thin that they were very prone to rips.

7.8 Workflow

The workflow for the new version of SurgiBox should be more intuitive and faster than the previous version.

1. Prep the surgical site as recommended for the application of an incise drape
2. Slip padded board for base of frame under patient

3. Remove SurgiBox enclosure from packaging
4. Peel backing from incise drape and place over surgical site
5. Unroll remainder of enclosure so it is lying deflated over the patient
6. Attach enclosure to environmental system tubing
7. Assemble pentagonal frame over patient
8. Place surgical tray and gloves in enclosure through large port
9. Inflate enclosure
10. Tie tethers to frame and surgical table
11. Users scrub and don one pair of gloves
12. Users place hands in sleeves and don additional pair of gloves
13. Begin procedure

This workflow is faster and simpler for users: the patient does not have to be moved in the same way as with the previous design, and the frame is quicker to set up. Because the system is one-size-fits-all, there is no concern of using the wrong size or adjusting the frame incorrectly.

8 Prototyping

I used an iterative design process, making several prototypes with specific goals in mind or specific design changes that I wanted to test. The following section shares fabrication techniques, alternate design ideas, and the development of the final design.

8.1 Fabrication Techniques

8.1.1 Sewing

When I first started testing an inflatable design, I sewed prototypes together. Former versions of SurgiBox had been made with a sewing machine, so I adopted previously-used fabrication techniques to test a new concept. While this may seem like a poor choice for fabricating an inflated enclosure, the holes from the needle proved to be small enough that the fan could easily inflate it anyway within a minute. This was an acceptable method for prototyping, but it was not ideal. First of all, it was extremely difficult to line up two pieces of slippery plastic to sew them together, making it a slow and painstaking process. Additionally, I knew it would not be the final fabrication method, so I looked to alternate methods that would represent a large-scale manufacturing method better.



Figure 13 Demonstrating a first prototype of an inflated enclosure. Method of fabrication: sewing

8.1.2 Hot Glue

I briefly experimented with a design that required multiple pieces of 16-gauge vinyl to be sealed together. I used hot glue, which slightly melted the vinyl and was an effective way of sealing two pieces together. However, similar to the sewing technique, it was very difficult to line up the pieces, and also was slow to cool, making it another difficult and time-consuming process.

8.1.3 Adhesives

Adhesives could be selected to work well to seal two pieces of similar plastics together. I did make a few prototypes with double-sided tape. The plastic had to be cleaned prior to applying the tape, and pressure had to be applied after to create an adequate seal.

8.1.4 Heat Sealing

Heat sealing was by far the best fabrication method for sealing pieces of LDPE together. The best heat sealer that I found was a six-inch BriskHeat 1F02200 Compact Portable Heat Sealer. I experimented with using a small, battery-powered heat sealer to 'tack' the plastic together, but found that this yielded mixed results. The heated wire of the small heat sealer was such a small diameter that it was prone to puncturing the plastic.

Ultimately, however, while the heat sealing is a fast and effective way of sealing LDPE, it is not an acceptable solution for the vinyl because it releases dioxin [26].

8.1.5 Jigs

I created some jigs to aid with the creation of prototypes. I created a trapezoidal plywood stencil for a sleeve pattern so I could quickly cut out identical pieces of plastic and seal them together.

8.2 Alternate Port Ideas

8.2.1 Plastic Zippers

Plastic zippers with a shuttle were considered as a potential sealing mechanism for a port. This was appealing because they are already tested in food storage bags—meaning the design of them has already been validated. However, the zippers are too difficult to open quickly. They are even more difficult to close, leading to the concern that they will not be closed if doctors are preoccupied with the procedure. They are difficult to open from both the inside or the outside, which was a concern of some doctors we talked with.

8.2.2 Pressurized Tubes

Another port design utilizes pressurized flexible LDPE tubes surrounding the port. The pressure within forces the ports closed and returns them to their closed position after being opened. This idea was eliminated due to the risk of puncturing the plastic while the ports were in use. Once the pressurized tube is deflated, it will no longer seal the port, thus making the entire system ineffective. Additionally, there was a large challenge of inflating the individual ports quickly before the procedure, because the internal pressure in the tubes would likely need to be greater than the internal pressure of the enclosure. Finally, it adds complexity that will increase the cost and time to manufacture.

8.2.3 Velcro

The idea of using Velcro was briefly considered as an easy way to close ports. However, Velcro does not seal well, meaning the airflow into the system would have to be increased to accommodate that. Additionally, there is no 'self-aligning' feature, meaning it would take concentration and focus to close the ports.

8.3 Development of Patient Interface

I started by brainstorming an adjustable frame that could be used with several versions of liner. This frame would be all one piece (unlike in previous versions of the frame, which breaks apart into several parts) and collapsible. Inspiration for the folding mechanism came mainly from folding camp chairs. The frame should be made of one part to make set-up easier and more intuitive, and to prevent the possibility of losing part.

Next, I imagined a new patient-liner interface in which the liner sits on top of the patient and is sealed to the surgical site. This could be implemented in a number of ways. First, a system was imagined in which the several rectangles of adhesive are concentrically attached to the underside of the liner. According to the patient size and type of surgery, a rectangle is chosen, inside the rectangle is cut out, the adhesive backing removed, and it would be placed on the patient's abdomen (or other surgical site).

However, a visit to the VA hospital in Roxbury, Massachusetts, inspired the use of an incise drape, which is commonly used in procedures. An incise drape is an adhesive drape that is placed on a prepped surgical site. The surgical incision cuts through the drape and patient's skin

at the same time. Incise drapes impregnated with iodophor are antimicrobial and can further help to reduce SSIs [27].

Through prototyping, it was discovered that the incise drape can be heat sealed to the LDPE enclosure, providing a quick and reliable way to attach it. It is advantageous to use incise drapes because most surgeons have used them before, making SurgiBox easier to adopt.

8.4 Testing the Inflatable Design

My initial tests of an inflatable design were made purely out of LDPE, and were to answer the questions of whether I could inflate a 0.2 cubic meter enclosure within 60 seconds, and whether the inflation could be maintained with a minimal maintenance flow

When I first created a prototype that eliminated the frame, two pressing questions that I needed to answer were whether it was able to provide adequate visual clarity and whether users could effectively work side by side. In order to have good visual clarity, the high-visibility plastic needs to be stretched taut enough that there is no distortion or distracting wrinkles.

The fan that I used had to provide a much higher airflow than fans for the previous versions of SurgiBox, because they had to quickly inflate the entire enclosure and provide a maintenance flow, compensating for any leaks in the system. The first fan I used has a diameter of two inches, and is sold as a hobbyist's motor for a remote control airplane. This fan could inflate a full-size enclosure in 45 seconds, and could then be slowed to provide a maintenance flow.

However, it was far too loud to be usable in an operating room. Two users side by side could not communicate with the fan on, even at a low speed. This demonstrated that, while a fan can

be used to inflate the enclosure and provide a maintenance flow, an important functional requirement is the volume of the environmental system.

In an attempt to find a quieter fan, I began testing larger fans, commonly used for ventilation in greenhouses or other small buildings. The next fan I used was a six-inch wall-powered fan. This fan was much quieter, showing that an inflatable system was possible. However, an important functional requirement for SurgiBox is that it can be operated with a battery in case of an unreliable or absent electrical grid, and rather than add an inverter to the design, I opted for sourcing a direct-current fan. The final fan selection is 12 volts direct current, has a four-inch diameter, and quiet enough to allow for users to communicate without raising their voices, even at full power.



Figure 14 Testing an inflated design with SurgiBox team member Rob Smalley

9 Testing and Validation

The design had to be validated to ensure that it met functional requirements set by the SurgiBox team. User testing ensures that the design is ergonomic, fits well into current surgical workflows, does not interfere with a procedure, and ultimately is easy enough to use that surgeons who recognize its benefit will be likely to incorporate it into their procedures.

Environmental testing is necessary to validate that it does what we claim it does: creates an environment of clean air over the surgical site with the intention of decreasing surgical site infections and protecting the providers.

9.1 User Testing

User testing is primarily happening at Massachusetts General Hospital (MGH) under the direction of Dr. David King. Throughout the design process, we worked with Dr. King, as well as Dr. Stephen Odom of Beth Israel Deaconess Medical Center (BIDMC). The majority of user testing will be occurring in January and February 2018, and results from these tests will guide the next design steps of the project.



Figure 15 User testing to ensure visual clarity is acceptable

9.2 Environmental Testing

9.2.1 Air quality testing

Environmental testing was completed with an optical particle counter, which reports the size breakdown of the particles.

The following is the protocol for particle testing.

1. Set up SurgiBox over mannequin
 1. Attach tethers to frame
2. Insert particle counter inlet at xiphoid on mannequin
 1. Insert particle counter tube through port and ensure port closes around tube to minimize leakage
3. Begin taking measurements (particles/m³)

1. Record six seconds on, ten seconds off
2. Take at least two measurements before inflating
4. Inflate using maximum airflow
5. Reduce airflow to maintenance
6. Continue to record until t=500s

Three trials were run and compared with the operating room standards for different particle sizes. The SurgiBox enclosure started off deflated but contaminated (i.e. open to the environment, so the air that was inside was not filtered). Section A is before inflation(0-60 seconds), section B is during inflation(60-120 seconds), and section C is during maintenance flow(120-500 seconds).

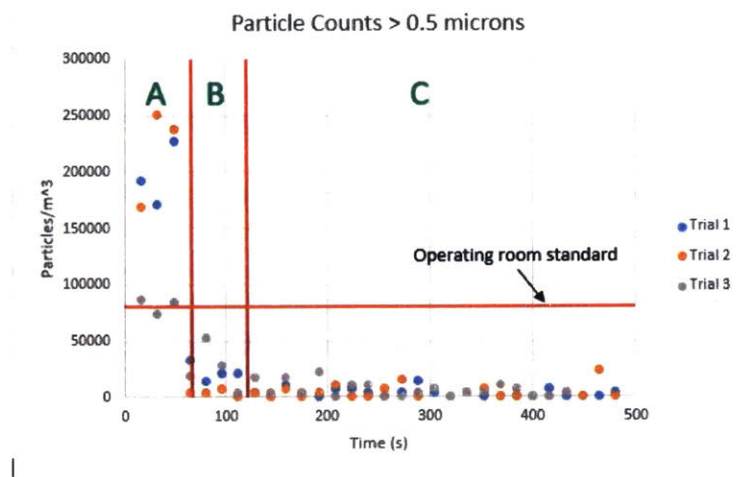

Figure 16 Particle testing for particles greater than 0.5 microns

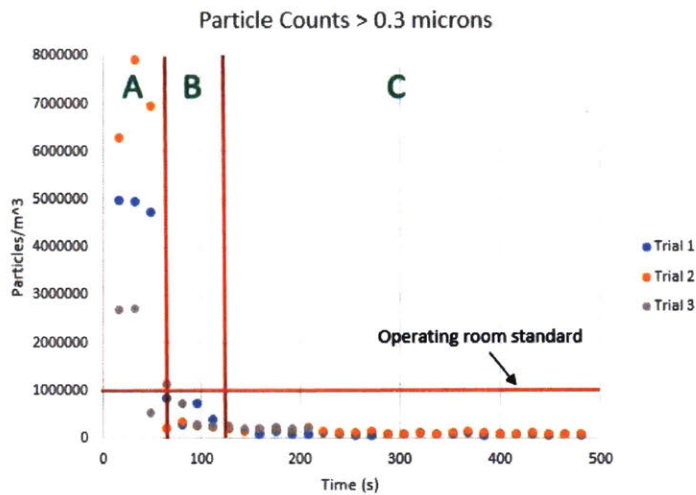

Figure 17 Particle testing for particles greater than 0.3 microns

9.2.2 Anti-Backflow Testing

In order to ensure that the anti-backflow system (integrated overhead tube) works well, the enclosure was filled with particles from a smoke machine. The fan was shut off, and the optical particle counter was then used to measure the number of particles at the fan inlet. If the number spiked, it would mean that the particles were travelling back through the overhead tube. However, several tests showed that the air particles at the inlet remained constant, and the anti-backflow method of introducing air through the overhead tube was validated.

10 Future Work

10.1 Lighting

One design feature that would be a potentially effective addition is a strip of overhead LED lighting, which could be taped to the outside of the enclosure to provide better lighting of the

surgical site. Something that the team has heard from several potential users is that lighting is often inadequate, even inside hospitals. This can be the result of lights that go unrepaired or unreplaced, or an unreliable electrical grid. Because SurgiBox has a battery component for the environmental control system, it would be a simple addition to include energy-efficient LED lights. The lights could be a reusable component, allowing them to pay for themselves over hundreds or thousands of surgeries.



Figure 18 Operating room in Cameroon, providing inspiration for SurgiBox design decisions

11 References

- [1] "The Second Global Patient Safety Challenge: Safe Surgery Saves Lives," World Health Organization, Geneva, 2008.
- [2] "Health Care Associated Infections: Fact Sheet," World Health Organization.
- [3] A. R. P. Committee, *Recommended Practices for Maintaining a Sterile Field*, AORN, 2006.
- [4] "AST Standards of Practice for Creating the Sterile Field," Association of Practice for Creating the Sterile Field, 2011.
- [5] A. Spagnolo, "Operating Theatre Quality and Prevention of Surgical Site Infections," *Journal of Preventative Medicine and Hygiene*, no. 54, pp. 131-137, 2013.
- [6] C. Quick, *Essential Surgery*, London: Elsevier, 2013.
- [7] J. G. Meara, "Global Surgery 2030: Evidence and Solutions for Achieving Health, Welfare, and Economic Development," *The Lancet Commission on Global Surgery*, 2015.
- [8] J. Fernandez, "All hands on deck to close the global surgery gap," Boston Children's Hospital, Boston, 2016.
- [9] J. Rose, "Estimated Need for Surgery Worldwide Based on Prevalence of Diseases: A Modelling Strategy for the WHO Global Health Estimate," *The Lancet Global Health*, 2015.
- [10] J. W. Blanchard, "Training to serve unmet surgical needs worldwide," *Journal of the American College of Surgeons*, no. 193, pp. 417-427, 2001.
- [11] M. Alicia J. Mangram, M. C. Teresa C. Horan, M. Michele L. Pearson, B. Leah Christine Silver and M. William R. Jarvis, "Guideline for Preventions of Surgical Site Infection," Centers for Disease Control and Prevention, Minneapolis, 1999.
- [12] "Frequently Asked Questions About Surgical Site Infections," Center for Disease Control, 14 December 2010. [Online]. Available: https://www.cdc.gov/hai/ssi/faq_ssi.html. [Accessed 2017 March 2017].
- [13] e. a. Diab-Elschahawi M, "Impact of different-sized laminar air flow versus no laminar air flow on bacterial counts in the operating room during orthopedic surgery," *American Journal of Infection Control*, no. 39, pp. 25-29, 2011.
- [14] R. Wenzel, "Minimizing surgical-site infections," *New England Journal of Medicine*, no. 362, pp. 75-77, 2010.
- [15] L. Sehulster, "Guidelines fo Environmental Infection Control in Health-Care Facilities," Center for Disease Control, 2003.

- [16] S. Odom, Interviewee, MD. [Interview]. November 2016.
- [17] A. Linden, "Challenges of Surgery in Developing Countries: A Survey of Surgical and Anesthesia Capacity in Uganda's Public Hospitals," *World Journal of Surgery*, no. 36.5, pp. 1056-1065, 2012.
- [18] L. F. Friedman, "Doctors Have Performed More Than 7,000 Surgeries Inside This Delivery Truck," *Business Insider*, 2014.
- [19] H. Frontani, "Success Story from Nigeria: Dr. Seyi Oyesola," *African Development Successes*, 2015.
- [20] B. Alkire, *How many people worldwide lack access to surgical care?*, Lancet Commission on Global Surgery, 2015.
- [21] C. Miller, "Battlefield injuries: Saving lives and limbs throughout history," *Lower Extremity Review*, 2013.
- [22] W. B. Fischer, "Enclosure for surgical procedures". US Patent 5316541 , 31 May 1994.
- [23] S. Kuslich, "Apparatus for establishing and maintaining a positive atmospheric pressure surgical field". US Patent 6199551 , 13 March 2001.
- [24] "Atmosbag glove bag - an inflatable polyethylene glove box alternative," Sigma Aldrich, [Online]. Available: <https://www.sigmaaldrich.com/labware/products/aldrich-atmosbag.html>. [Accessed 8 January 2018].
- [25] G. Kieves, "Self-sealing valve, a self-sealing, non-latex balloon and a method for producing such a balloon". Europe Patent EP 0356013 A2, 28 February 1990.
- [26] D. Morrison, "Pro/Con: Vinyl is Lethal," 10 January 2009. [Online]. Available: <http://www.greenbuildingadvisor.com/blogs/dept/green-building-blog/procon-vinyl-lethal>. [Accessed 15 January 2018].
- [27] "Surgical site infections: prevention and treatment," NICE, October 2008. [Online]. Available: <https://www.nice.org.uk/guidance/CG74/chapter/1-Guidance#intraoperative-phase>. [Accessed 22 December 2017].
- [28] R. a. J. B. Goodier, "7 Medical Upgrades for Developing Countries," *Popular Mechanics*, 10 June 2015.

12 Appendix

12.1 Airflow algorithm

The following is the methodology developed by Dan Frey to determine the placement of perforations in the overhead inflow tube.

In the preferred embodiment, there is a collapsible tube that delivers air to the region of the enclosure where the surgery is conducted. An advantage of the invention is that filtered air is delivered nearly uniformly throughout the enclosed space. This is accomplished by a varying density of perforations in the collapsible tube in which the density of perforations is higher at the end of the tube closer to the supply of the air and the density of perforations decreases as the distance from the supply increases. To accomplish nearly uniform air flow, the manner in which the perforation density decreases is according to the inverse of an elliptically shaped function.

As it is known to a person with ordinary skill in the art of air handling, the pressure within an inviscid flow will rise along a streamline if the velocity of the airflow decreases. In a perforated tube of constant cross sectional area, the velocity within a tube will drop as it passes perforations from which flow is emanating as long as the flow is of nearly constant density which will be the case for flows of air substantially below the speed of sound. Therefore, the pressure in a perforated tube rises as the distance from the source increases. This causes the rate of flow from each perforation to rise with distance from the source assuming the perforations are of constant cross sectional area. If the density of perforations were uniform, the flow of air would be too great at locations far from the source and too little at locations nearer to the source.

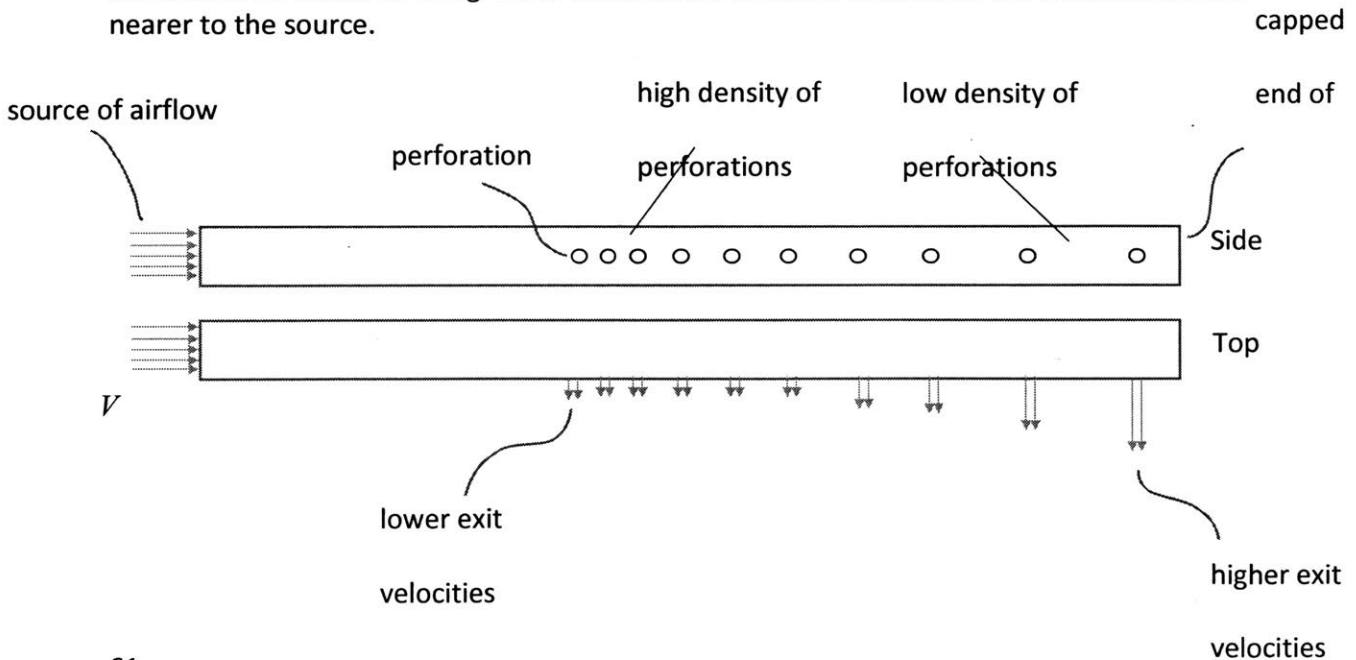

The specific form of the perforation density needed for uniform air flow can be determined by an iterative computation. Begin with an assumed form of the exit velocities such as a linearly increasing distribution. These assumed exit velocities will be denoted as v_j with a unique subscript for each of the many holes numbered $j=1$ to k . From the estimated exit flow velocities, one may compute an estimate of the velocities within the tube v_{tube} flowing from left to right. Mass conservation requires that for any hole number n in a tube of diameter D with perforations of diameter d

$$\dot{m} = \sum_{j=1}^n v_j \rho \frac{\pi}{4} d^2 + v_{tube} \rho \frac{\pi}{4} D^2$$

If the flow axially within the interior of the tube can be modelled as inviscid flow, then Bernoulli's equation can provide a prediction of the pressure within the tube as a function of the velocities just computed in the previous step. First, assuming that the velocity in the tube near the end cap is zero and the velocity at the source is V and the constant air density is ρ , we

$$P = \frac{1}{2} \rho V^2$$

the tube farthest from the source as

Then this value of the pressure P can be used to estimate the pressures within the tube at each of the many holes numbered $j=1$ to k

$$p_j = P + \frac{1}{2} \rho V^2 - \frac{1}{2} \rho v_{tube_j}^2$$

These pressures at each hole are computed and stored in a vector.

Based on the results from the previous step, one can form a new estimate of exit velocities. If the flow from the interior of the tube to the exit hole can be modelled as inviscid flow, then Bernoulli's equation can provide a prediction of the exit velocity.

$$v_{u_j} = \sqrt{\frac{2}{\rho} p_j}$$

One may use the relationship above k times (for each hole number from 1 to k) to calculate exit velocities at each hole. At this stage of the process, there will be updated exit velocity estimates v_{u_j} which are different from the initially assumed distribution. By mass conservation, the sum of the exit velocities must be obey the relationship

$$\dot{m} = \sum_{j=1}^k v_j \rho \frac{\pi}{4} d^2$$

In the next step of the process, preserve the proportions among the computer exit velocities

v_{uj} but their magnitudes are adjusted to satisfy mass conservation by scaling each value dividing it by the sum $\sum_{j=1}^k v_j \rho \frac{\pi}{4} d^2$ and multiplying it by the known mass flow supply \dot{m} . The resulting exit velocity distribution is used as an updated estimate and the process is iterated until it converges to a stable distribution which will be approximately elliptical if the total area of perforations is not small compared to the cross sectional area of the tube. By making the density of perforations an inverse of an elliptically shaped function, the resulting air distribution within the surgical area is uniform throughout.

As an illustration, the resulting velocity distribution and perforation density distribution are graphically depicted in exhibit X. This computation is for a case with ten perforations in the collapsible tube. The hole number is on the x axis and the exit velocity and perforation densities (normalized so that the maximum values are unity) are represented on the y axis.

