

## MIT Open Access Articles

*Multi-Disciplinary Design Optimization for  
Large-Scale Reverse Osmosis Systems*

The MIT Faculty has made this article openly available. *Please share*  
how this access benefits you. Your story matters.

**Citation:** Yu, Bo Yang, Tomonori Honda, Syed Zubair, Mostafa H. Sharqawy, and Maria C. Yang. "Multi-Disciplinary Design Optimization for Large-Scale Reverse Osmosis Systems." Volume 2A: 40th Design Automation Conference (August 17, 2014).

**As Published:** <http://dx.doi.org/10.1115/DETC2014-35032>

**Publisher:** ASME International

**Persistent URL:** <http://hdl.handle.net/1721.1/120027>

**Version:** Final published version: final published article, as it appeared in a journal, conference proceedings, or other formally published context

**Terms of Use:** Article is made available in accordance with the publisher's policy and may be subject to US copyright law. Please refer to the publisher's site for terms of use.



**DETC2014-35032**

## **MULTI-DISCIPLINARY DESIGN OPTIMIZATION FOR LARGE-SCALE REVERSE OSMOSIS SYSTEMS**

**Bo Yang Yu , Tomonori Honda**  
Department of Mechanical Engineering  
Massachusetts Institute of Technology  
Cambridge, MA 02139

**Syed Zubair, Mostafa H. Sharqawy**  
Mechanical Engineering Department  
King Fahd University of Petroleum and Minerals  
Dhahran 31261  
Saudi Arabia

**Maria C. Yang**  
Department of Mechanical Engineering and Engineering Systems  
Massachusetts Institute of Technology  
Cambridge, MA 02139

### **ABSTRACT**

*Large-scale desalination plants are complex systems with many inter-disciplinary interactions and different levels of sub-system hierarchy. Advanced complex systems design tools have been shown to have a positive impact on design in aerospace and automotive, but have generally not been used in the design of water systems. This work presents a multi-disciplinary design optimization approach to desalination system design to minimize the total water production cost of a 30,000m<sup>3</sup>/day capacity reverse osmosis plant situated in the Middle East, with a focus on comparing monolithic with distributed optimization architectures. A hierarchical multi-disciplinary model is constructed to capture the entire system's functional components and subsystem interactions. Three different multi-disciplinary design optimization (MDO) architectures are then compared to find the optimal plant design that minimizes total water cost. The architectures include the monolithic architecture multidisciplinary feasible (MDF), individual disciplinary feasible (IDF) and the distributed architecture analytical target cascading (ATC). The results demonstrate that an MDF architecture was the most efficient for finding the optimal design, while a distributed MDO approach such as analytical target cascading is also a suitable approach for optimal*

*design of desalination plants, but optimization performance may depend on initial conditions.*

### **INTRODUCTION**

Multidisciplinary design optimization (MDO) is a set of tools used by system engineers to optimize the design of a system that involves many disciplines or subsystems. The challenges that arise in MDO have largely been in the numerical complexity of performing system wide modeling [1]. To mitigate the numerical complexity, a number of strategies or methods for problem formulation and subsystem organization have been proposed, also known as MDO architectures [1–4]. An MDO architecture can be either monolithic or distributed. Examples of monolithic architectures include Multi-Disciplinary Feasible (MDF) and Individual Discipline Feasible (IDF) [2, 5, 6], where a single optimization problem is solved. In a distributed approach the problem is partitioned into multiple subproblems, examples include Collaborative Optimization (CO), Bi-Level Integrated Synthesis System (BLISS), and Analytical Target Cascading (ATC), to name a few [7–11]. A number of studies have been conducted to compare the effectiveness and limitations of different MDO architectures, and these studies have suggested

that the performance of an MDO architecture often depends on the nature of the problem [1, 12]. Therefore, it is imperative for engineers to test multiple architectures on a given problem.

Desalination processes remove salt from saline water to produce fresh water. Large-scale desalination plants (with capacity of 30,000 m<sup>3</sup>/day or more) have been constructed in the Middle East since the early 1960's to alleviate the region's water shortage. As the cost of desalination technologies, especially reverse osmosis (RO) technology, continue to decrease, large-scale reverse osmosis desalination plants are being constructed in other areas around the world.

The majority of reverse osmosis numerical optimization studies only consider the reverse osmosis process itself. As of today, designers in the field of desalination have not attempted to apply techniques developed in systems engineering, such as MDO, in the modeling and optimization of desalination systems. The reason for this may be that the RO process itself is of a scope that can be handled by a small design team. However, when considering the desalination system as a whole, including pre-treatment, life-cycle operation, and energy availability, the system becomes far more complex with major interactions between subsystems and components. As the world population continues to grow and fresh water supplies dwindle, there will be more desalination plants constructed around the world. Future desalination plant designers will face the problem of designing regional desalination networks, where a number of desalination plants must work together cohesively while sharing limited energy resources. These properties of desalination systems make them an ideal case example for studying systems engineering techniques such as multi-disciplinary design optimization.

The objective of this study will be to investigate which type of MDO architectures are best suited for finding the optimal design of a reverse osmosis desalination system. The performances of several different MDO architectures are compared using a 30,000 m<sup>3</sup>/day reverse osmosis plant in the Middle East as a case study. This study also serves the purpose of presenting a real world test problem that will contribute to the on-going research of evaluating novel MDO architectures.

## RELATED WORK

### Optimization of Reverse Osmosis System

A number of different studies have examined numerical optimization of RO processes, including optimization under different feed concentrations [13], optimization of energy costs based on electricity supply [14], optimization for both capital and operational costs [15], and optimization considering membrane fouling [16]. All of these works only considered the RO process itself in rather than a broader systems-oriented approach. Vince, et al. [17] considered both energy consumption and cost in a multi-objective optimization approach of RO plants, though their system model is also limited to the RO process alone. Kim,

et al. [18] published an overview of systems engineering approaches for large-scale seawater desalination plant. They reviewed over 100 papers related to the different subsystems of a RO plant. However, they did not attempt to map the interactions between the major subsystems, nor propose methods for system-wide optimization.

## MDO Architectures

A number of surveys and comparison studies of MDO architectures has been reported in the past decade. Martins, et al. [1] compiled a comprehensive list of all existing MDO architectures to date, and included descriptions of features, merits, and expected performance. Perez, et al. [19] performed an extended evaluation of five different architectures, based on metrics of simplicity, transparency, portability, efficiency and accuracy, using an aircraft conceptual design case study. de Wit and Keulen [20] compared six different distributed MDO methods based on performance and efficiency, using a simple two-beam truss structure as an example. Allison, et al. [5] compared the performance between MDF and IDF architectures with test problems of varying complexity. Honda, et al. [21] compared different information passing strategies in distributed MDO architectures. Brown, et al. [12] compared MDO methods with fixed-point iteration methods using a case example of a reusable launch vehicle. The limitations of these comparison studies include low dimensionality of test problems and inconsistency of programming skills between research groups. The consensus from these studies is that the most appropriate architecture will depend on the nature of the problem [1, 12, 19].

To the best of the authors' knowledge, there has not been a study in which systems engineering tools are used to analyze an RO desalination plant, capture the interactions between pre-treatment, the RO process, operations and energy consumption. Moreover, multi-disciplinary optimization has also not been applied to desalination technologies. This paper seeks to fill the gap by considering reverse osmosis plants at a systems level using MDO techniques.

## METHODOLOGY

In this study several different MDO architectures are applied to the numerical design optimization of a reverse osmosis plant, to compare the performance of different architectures in desalination technology applications. This section outlines the methodologies associated with modeling of the desalination system and implementation of the MDO architectures.

### Reverse Osmosis System Model Development

In this case study, a 30,000m<sup>3</sup>/day capacity seawater reverse osmosis plant is planned for a specific location on the coast of the Arabian Gulf. Actual cost and capacity numbers from an existing

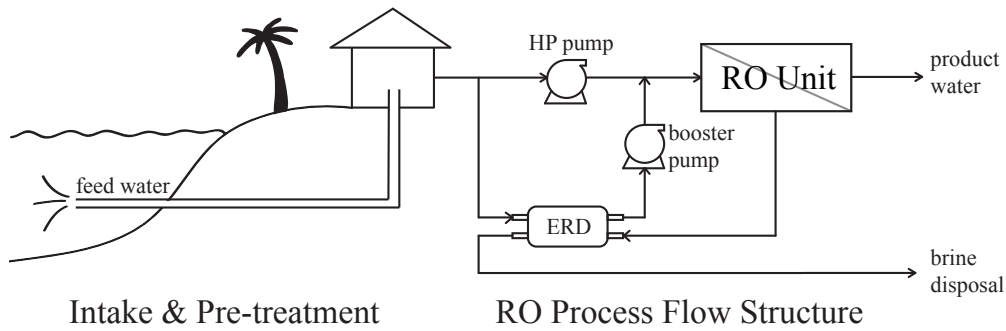

**FIGURE 1.** SYSTEM DIAGRAM OF REVERSE OSMOSIS PLANT [18]

desalination plant is being used to calibrate model parameters. The system boundary of a reverse osmosis desalination system is defined to include the intake and pre-treatment system, the RO process, including the pumps and energy recovery devices, the RO membranes and pressure vessels, and the life-cycle analysis considering capital, maintenance and energy costs. The energy required for the RO plant is assumed to be coming from the electric grid, and the post-treatment process and water distribution system is not considered.

Figure 1 shows the layout of the reverse osmosis plant being modeled. Three different subsystems can be identified based on the plant layout: the intake & pre-treatment (IP) subsystem, which deals with preparing the feed seawater for desalination, the RO process flow structure (FS) subsystem, which is focused on the selection of pumps, energy recovery devices (ERD) and how they are connected, and the RO pressure vessel (RO) subsystem that specialize in selecting the RO membrane and designing the pressure vessel rack. The life-cycle analysis (LC) that deals with the finance, operation and maintenance of the plant is a fourth subsystem.

The IP subsystem covers the design choices associated with the intake technology and pre-treatment technology. For this study, two intake structures are possible based on geographical constraints: deep water intake or shallow water intake. Two different pre-treatment processes are possible, conventional pre-treatment with cartridge filters or ultra-filtration pre-treatment [22, 23]. The capital cost, operational cost and energy consumption of the intake and pre-treatment system depends on the combination of intake and pre-treatment choices [23, 24], as well as the intake seawater flowrate [25]. The mathematical formulation for the IP subsystem is:

$$[CC_{IP}, EC_{IP}, OC_{IP}] = f_{IP}(Q_{in}, I_{intake}, I_{pre}) \quad (1)$$

where CC, EC, OC stand for capital cost, energy consumption, and operational cost,  $Q_{in}$  is the intake seawater flowrate, while  $I_{intake}$  and  $I_{pre}$  are integer variables indicating the choices of technology in intake and pre-treatment respectively. In this model of the plant, there are two different possible technology choices: shallow open intake and deep open intake, the cost of intake structures are considered fixed. Two pre-treatment technology choices were considered: conventional pre-treatment and ultra-filtration. The costs of pre-treatment technologies are modeled by power laws.

The FS subsystem covers the discipline specific to the RO process flow, configuring the connectivity between pumps, pressure vessels, and energy recovery devices. The majority of RO optimization work in the past has focused on this area, and many novel approaches have been developed, especially superstructure optimization [17, 26]. In this study, a constant single-pass single-stage flow structure will be implemented. The mathematical formulation for the FS subsystem is:

$$[CC_{FS}, EC_{FS}, Q_f, Q_p, c_f] = f_{FS}(Q_{in}, P_f, N_{train}, r, SR, P_{drop}) \quad (2)$$

where  $Q_f$  and  $c_f$  are the flow rate and the salt concentration of the feed water entering the RO pressure vessel rack,  $Q_p$  is the fresh water product flow rate,  $P_f$  is the feed pressure,  $N_{train}$  is the number of individual trains,  $r$ ,  $SR$ ,  $P_{drop}$  are outputs from the RO unit subsystem, which are recovery ratio, salt rejection ratio, and pressure drop across the RO unit, respectively. For additional details of the flow structure model refer to [17].

The RO subsystem covers the design of the pressure vessel rack, and the selection of membrane. A library of seawater RO membranes is constructed based on information supplied by the Dow Chemical Company. A physics-based model is constructed that computes the permeate and brine conditions based on feed

water properties such as flow rate and pressure. The choice of the pre-treatment technology plays a major role in the design of the pressure vessels, since the result of pre-treatment will affect the feed water quality, which governs the maximum allowable recovery ratio of the membrane. The mathematical formulation of the RO subsystem is:

$$[CC_{RO}, CC_{memb}, r, SR, P_{drop}] = f_{RO}(N_{PV}, N_{memb}, I_{RO}, Q_f, P_f, c_f, I_{pre}) \quad (3)$$

where  $N_{PV}$  is the number of pressure vessels in parallel,  $N_{memb}$  is the number of RO membranes inside a single pressure vessel,  $I_{RO}$  is the type of RO membranes selected from the membrane library. All three of these variables are integer variables. All pressure vessels are identical and are connected in parallel. In each pressure vessel,  $N_{memb}$  number of identical RO membranes are connected in series, and each RO membrane is modeled using a solution-diffusion lumped parameter model. The solution-diffusion model is commonly used to describe the behavior of RO membranes, details of the model can be found in references: [16, 17, 27].

The life-cycle (LC) subsystem first determines the cost of operating the RO unit based on flow rate, membrane type, and pre-treatment technologies, then combine the operational cost with the rest of the costs, amortized over the life-cycle of the plant to compute a total water price (TWP) in  $\$/m^3$  of water produced. The plant is assumed to have a life-cycle of 25 years, the discount rate is 5%, and the electricity cost is  $\$/kWh$ . The mathematical formulation of the subsystem is:

$$TWP = f_{LC}(CC_{RO}, CC_{memb}, CC_{FS}, CC_{IP}, EC_{FS}, EC_{IP}, OC_{IP}, Q_{in}, Q_p, I_{pre}, N_{train}) \quad (4)$$

Figure 2 shows the  $N^2$  diagram of the reverse osmosis systems. There are a total of eight input variables to the system, and one objective variable as output. The diagram suggests that there is a strong coupling between the subsystems FS and RO as indicated by the feedback loop between them, and only a weak coupling between the rest of the subsystems. The IP, FS, and RO subsystems all have outputs that feed into the life-cycle subsystem, forming a hierarchy of three lower level subsystems reporting to a central system administrator. The variables associated with each subsystem and their connectivity are shown in Table 1.

The mathematical formulation of the design optimization problem of this reverse osmosis plant is shown below:

**TABLE 1.** Number of variables in subsystems

	IP	FS	RO	LC
<b>input variables</b>				
design variable (shared)	3(2)	3(3)	4(1)	3(3)
coupling variable	0	3	3	8*
total:	3	6	7	11
<b>output variables</b>				
shared with upper level	3	3	3	0
shared with lower level	0	3	3	0
objective	0	0	0	1
total:	3	6	5	1

\*outputs of lower level subsystems

$$\begin{aligned} \min_{\mathbf{x}} \quad & TWP = f_{LC}(y_{IP}, y_{FS}, y_{RO}, x_{LC}) \\ \text{s. t.} \quad & y_{IP} = f_{IP}(x_{IP}) \\ & [y_{FS}, y_{FS-RO}] = f_{FS}(x_{FS}, y_{RO-FS}) \\ & [y_{RO}, y_{RO-FS}] = f_{RO}(x_{RO}, y_{FS-RO}) \\ & \mathbf{g}(\mathbf{x}) \leq 0 \\ & \mathbf{x} = [x_{IP}, x_{FS}, x_{RO}, x_{LC}] \end{aligned} \quad (5)$$

Where  $\mathbf{x}$  is the design variable vector,  $y_{sub}$  are the intermediate state variables, and  $\mathbf{g}(\mathbf{x})$  are the constraints associated with the system. A summary of design variables and their respective bounds are presented in Table 2. Constraints that are considered include the following:

1. water production equal to 30,000m<sup>3</sup>/day
2. product water TDS less than 500ppm
3. feed water flow rate less than 150,000m<sup>3</sup>/day
4. feed pressure less than rated maximum
5. single membrane flow rate less than rated maximum
6. single membrane recovery rate less than rated maximum

## MDO Architectures

Three different architectures are tested in this study, which include two of the most common monolithic architectures: Multi-disciplinary feasible (MDF) and Individual Discipline Feasible (IDF). The third architecture is analytical target cascading (ATC), which is a distributed architecture. Due to the mixed integer nature of the design problem, distributed architectures

**TABLE 2.** Summary of Design Variables

Symbol	Description	Bounds
$N_{PV}$	Number of pressure vessel (PV)	up to 100
$N_{memo}$	Number of membranes per PV	up to 8
$N_{train}$	Number of RO trains	up to 6
$I_{RO}$	Type of membrane	4 types to choose from
$I_{intake}$	Type of intake structure	shallow vs deep
$I_{pre}$	Type of pre-treatment	conventional vs ultra-filtration
$Q_{in}$	Feed water flow rate	50,000 to 100,000 m <sup>3</sup> /day
$P_f$	Feed water pressure	50 to 83 bar

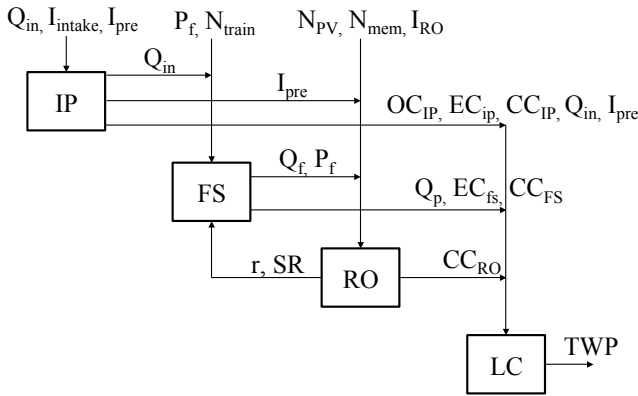

**FIGURE 2.** N<sup>2</sup> DIAGRAM OF REVERSE OSMOSIS PLANT

that require gradient information such as BLISS cannot be used. Analytical target cascading is a more recently developed architecture that has shown to work with mixed-integer problems [28], and thus selected for this application. Detailed descriptions of each of the three architectures are provided below.

**Multidisciplinary feasible (MDF)** The MDF architecture is the most straight-forward architecture, and its formulation has the fewest design variables of any monolithic architecture [1, 5, 19]. In this architecture (Figure 3a) the optimization routine wraps around a multidisciplinary design analysis (MDA), which iterates through the disciplines sequentially until a feasible design is reached. The advantage of MDF, besides its simple problem definition, is that it always produces a feasible design. The disadvantage is that coupled subsystem models may need to be evaluated several times before convergence, resulting in long computation time. The mathematical formulation of the MDF

architecture is:

$$\begin{aligned} \min_{\mathbf{x}} \quad & \text{TWP} = f_{\text{MDA}}(f_{\text{IP}}, f_{\text{FS}}, f_{\text{RO}}, f_{\text{LC}}) \\ \text{s. t.} \quad & \mathbf{g}(\mathbf{x}) \leq 0 \end{aligned} \quad (6)$$

There is only one optimization routine in the MDF architecture, and the optimization stops when the objective function reaches a steady-state value and the design satisfies all constraints.

**Individual discipline feasible (IDF)** In the IDF architecture shown in Figure 3b, complete MDA is avoided by including the coupling variables in the optimization routine as decision variables, and introducing consistency constraints to ensure feasibility. IDF results in a larger optimization problem, but each subsystem model only needs to be evaluated once in every optimization iteration. The disadvantage is that the system design may not be feasible until the optimization process converges. The mathematical formulation of the IDF architecture is:

$$\begin{aligned} \min_{\mathbf{x}, \hat{\mathbf{y}}} \quad & \text{TWP} = f_{\text{MDA}}(f_{\text{IP}}, f_{\text{FS}}, f_{\text{RO}}, f_{\text{LC}}) \\ \text{s. t.} \quad & \mathbf{g}(\mathbf{x}) \leq 0 \\ & \hat{y}_{\text{FS-RO}} - y_{\text{FS-RO}}(x, \hat{y}_{\text{RO-FS}}) = 0 \\ & \hat{y}_{\text{RO-FS}} - y_{\text{RO-FS}}(x, \hat{y}_{\text{FS-RO}}) = 0 \end{aligned} \quad (7)$$

where  $\hat{y}$  is a copy of the coupling variable. There is also only one optimization routine in the IDF architecture, however, there are a few more variables in the optimization and the associated equality constraints. The optimization stops when the objective function reaches a steady-state value and all equality constraints and design constraints are satisfied.

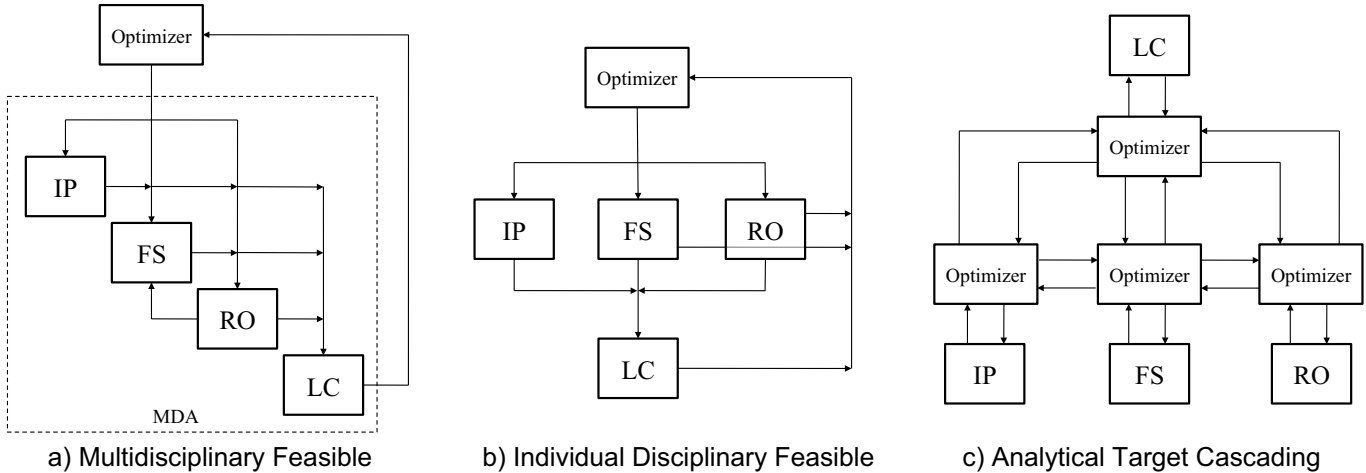

FIGURE 3. MULTIDISCIPLINARY DESIGN OPTIMIZATION ARCHITECTURES

**Analytical Target Cascading (ATC)** The ATC architecture (Figure 3c) takes advantage of the hierarchical structure of the system. An optimization problem is formulated for every subsystem to meet a set of performance targets. Instead of introducing equality constraints on the targets and coupling variables, a Lagrangian relaxation penalty function is formulated [29, 30]. The targets of lower-level subsystems are cascaded from the optimization results of upper-level subsystems. The advantages of the ATC architecture are mainly in its distributed nature, fairly easy to implement, minimizing the necessary communications between subsystems, and allow parallel processing of some of the subsystems. The disadvantage is that ATC, like other distributed architectures, are numerically inefficient compared to a monolithic architecture, and require a large number of function and discipline evaluations [1]. The mathematical formulation of the ATC architecture is shown in Equations 8 and 9.

$$\begin{aligned} \min_{\mathbf{x}, \hat{\mathbf{y}}_L} f_{MDA}(f_{IP}, f_{FS}, f_{RO}, f_{LC}) + \phi_{LC}(\hat{\mathbf{y}}_L, \mathbf{y}_L) \\ \text{s. t. } g_{LC}(\mathbf{x}) \leq 0 \end{aligned} \quad (8)$$

Equation 8 shows the formulation of the upper level problem, where  $\phi_{LC}$  is an augmented Lagrangian penalty function based on the responses from the lower level subsystems  $\mathbf{y}_L$ .

$$\begin{aligned} \min_{\mathbf{x}_i, \hat{\mathbf{y}}_{L,i}, \hat{\mathbf{y}}_{U,i}} \phi_{U,i}(\hat{\mathbf{y}}_{U,i}, \mathbf{y}_{U,i}) + \phi_{L,i}(\hat{\mathbf{y}}_{L,i}, \mathbf{y}_{L,i}) \\ \text{s. t. } [\mathbf{y}_{U,i}, \mathbf{y}_{L,i}] = \mathbf{f}_i(\mathbf{x}_i, \hat{\mathbf{y}}_{U,i}, \hat{\mathbf{y}}_{L,i}) \\ g_i(\mathbf{x}) \leq 0 \end{aligned} \quad (9)$$

Equation 9 outlines the general formulation of the lower level problems, where the objective is to minimize the discrepancy be-

tween the system response and upper level target  $\phi_{U,i}$ , and also the discrepancy between variables shared among lower level subsystems  $\phi_{L,i}$ . There are in total four optimization routines in this architecture, one for each subsystem. ATC runs in an iterative fashion, the targets and responses update during each iteration. The optimization is complete when the objective function reaches a steady-state value, and the targets' and responses' values converge, indicated by  $\phi \rightarrow 0$ .

For this study, the optimization architectures are implemented in Matlab 2013b, using the built-in genetic algorithm function `ga` which is capable of handling mixed-integer problems, and it used for solving the optimization problems in each of the architecture.

## RESULT

The reverse osmosis plant design problem outlined in the previous section is solved independently with each of the three MDO architectures. The Matlab default settings for the mixed-integer genetic algorithm [31] was used with some modifications: the number of population is set to 50, and the maximum number of generations is set to 600. Since the mixed integer GA does not accept equality constraints, the equality constraints IDF architecture are implemented as inequality constraints using the absolute value function and a relaxation value of 0.001.

Each of the MDO architectures was executed five times independently, while a counter algorithm is implemented to keep track the number of times each subsystem function is evaluated. Table 3 summarizes the number of function evaluations, showing the average numbers of function evaluations from the five independent analyses. The monolithic architectures have comparable complexity in terms of function evaluations, IDF has higher numbers of function evaluation due to a higher number of variables and the additional equality constraints. Due to the coupling na-

**TABLE 3.** MDO Architectures Complexity Comparison

	MDF	IDF	ATC
# of optimizer	1	1	4
# of variables	8	12	27
# of equality constraints	0	4	0*
system iterations	-	-	11
function evaluations			
IP	5,303	15,445	29,179
FS	10,606	15,445	59,802
RO	10,606	15,445	35,330
LC	5,303	15,445	197,132
<b>Total</b>	<b>31,818</b>	<b>61,782</b>	<b>321,444</b>

\*inconsistencies between targets and responses are penalized in optimization objective function

ture of the FS and RO subsystems, they are evaluated more times compared to the IP and LC subsystems in the MDF architecture. The ATC architecture is significantly more complex compare to the other two, with an order of magnitude more function evaluations. This was to be expected since ATC is an iterative process.

Out of the five independent executions of each MDO architecture, the resulting design with the lowest TWP was selected and presented in Table 4. MDF and ATC resulted in very similar designs with total water price equal to \$0.52/m<sup>3</sup>. IDF on the other hand, produced a design that has a higher total water price that is less optimal compared to the results of MDF and ATC, although IDF and MDF have been shown to provide equally optimal results in past studies [2, 32]. This discrepancy observed here could be caused by the added complexity to the non-linear equality constraints in IDF optimization problem. Fine tuning of the genetic algorithm should improve the performance of IDF.

### Effects of Initial Design on ATC

The ATC architecture requires an initial design point to provide the necessary intermediate variables. Three different initial design points were tested to compare the effects of different initial designs on the performance of the ATC architecture. The results are shown in Table 5.

Case 1 used a feasible design as the initial starting point, case 2 used a different feasible design as initial starting point, although less optimal compared to the initial design in case 1 (low recovery, high pressure, high TWP), and case 3 used a infeasible initial design point. In the first case ATC found a solution with a TWP value very similar to the results of the MDF architecture. In case 2, the final solution is more optimal compared to the ini-

**TABLE 4.** Optimization Results

	MDF	IDF	ATC
Number of PV	95	91	71
Number of membranes/PV	7	6	8
Number of RO trains	5	6	5
Type of intake structure	shallow	shallow	shallow
Type of pre-treatment	UF*	UF	UF
Feed water flow rate [m <sup>3</sup> /d]	75,500	86,200	64,300
Feed water pressure [bar]	68.6	61.7	71.7
System recovery	46.2%	36.3%	47.9%
Total water price [\$/m <sup>3</sup> ]	0.52	0.55	0.52

\*Ultra-filtration

tial design, indicated by the lower objective function value (total water price), but less optimal compared to the results found previously. In case 3, when a completely infeasible initial design point was used, the ATC architecture failed to converge even after 100 system iterations (compared to < 20 iterations for the first two cases).

The results show that the design found through ATC is highly dependent on the initial design point. This problem is caused by the mixed-integer nature of the design problem. Studies in the past have noted that mixed-integer implementations of ATC tend to converge prematurely [28], and this is evident in case 2, where the "type of intake" and "type of pre-treatment" did not change from the initial design point.

### CONCLUSIONS AND FUTURE WORK

In this study, systems engineering techniques are applied to the design and optimization of a large scale reverse osmosis desalination system. Four subsystems and their interactions are identified and modeled using a mixed-integer numerical model. The system model includes intake and pretreatment, as well as life-cycle operation and finance analysis of the plant, both of which are rarely considered in previous studies involving numerical optimization of desalination plants. Three different multidisciplinary design optimization architectures: multidisciplinary feasible (MDF), individual disciplinary feasible (IDF) and analytical target cascading (ATC) are applied in the numerical optimization of the desalination system, and their performances are compared in terms of design optimality and complexity. The results show that for this particular system model with a relatively low degree of fidelity (eight design variables and only strong coupling between two of the four subsystems), the MDF architecture produced the most optimal design with the least number of func-



**TABLE 5.** Effects of Initial Design on ATC Results

	initial 1	final 1	initial 2	final 2	initial 3	final 3
Number of PV	65	71	90	58	1	-
Number of membranes/PV	7	8	5	6	1	-
Number of RO trains	6	5	6	4	1	-
Type of intake structure	shallow	shallow	deep	deep	shallow	-
Type of pre-treatment	UF	UF	conv.*	conv.	conv.	-
Feed water flow rate [m <sup>3</sup> /d]	77,300	64,300	84,000	76,800	50,000	-
Feed water pressure [bar]	70	71.7	80	81	50	-
System recovery	44%	47.9%	35.9%	41.8%	-	-
Total water price [\$/m <sup>3</sup> ]	0.55	0.52	0.60	0.56	-	-
System iteration		11		17		D.N.C. <sup>†</sup>

\*conventional

<sup>†</sup> did not converge

tion evaluations. ATC is also capable of producing highly optimal design, but requires significantly higher numbers of function evaluation, and the final result is affected by the initial design point.

This paper demonstrated that the complexity associated with desalination plants requires the use of system engineering techniques to model and capture full system interactions. Extension of this work should focus in two different areas. First is to increase system model fidelity by including water distribution subsystem and energy source subsystems, and eventually create a regional desalination network system model that include multiple desalination plants and power plants that service the water and energy demand of a local area.

Although the monolithic architecture MDF is shown to be the most effective architecture in this study, distributed architectures still have merits in areas such as parallel processing, and organization of distributed design teams, both of which are critical in the design of large-scale systems such as the energy-water network described above. Analytical target cascading is a promising technique but has its limitations when applying to mixed-integer design problems. Therefore more distributed MDO architectures should be evaluated in the future to find the best distributed architecture for large-scale water systems.

## ACKNOWLEDGMENT

The authors would like to thank the King Fahd University of Petroleum and Minerals in Dhahran, Saudi Arabia, for funding the research reported in this paper through the Center for Clean Water and Clean Energy at MIT and KFUPM under project number R13-CW-10. Thanks also to Dr. Olivier de Weck,

Chris Tubis, Vivek Sakhrani, Waleed Gowharji, and Abdullah Alkhenani for their inputs and suggestions to this work. This work also received partial support from the National Science and Engineering Council of Canada. The opinions, findings, conclusions, and recommendations expressed are those of the authors and do not necessarily reflect the views of the sponsors.

## REFERENCES

- [1] Martins, J., and Lambe, A. B., 2012. "Multidisciplinary design optimization: Survey of architectures". *AIAA Journal*.
- [2] Cramer, E. J., Dennis, Jr, J., Frank, P. D., Lewis, R. M., and Shubin, G. R., 1994. "Problem formulation for multidisciplinary optimization". *SIAM Journal on Optimization*, **4**(4), pp. 754–776.
- [3] Balling, R. J., and Sobieszcanski-Sobieski, J., 1996. "Optimization of coupled systems—a critical overview of approaches". *AIAA journal*, **34**(1), pp. 6–17.
- [4] Tosserams, S., Etman, L. P., and Rooda, J., 2009. "A classification of methods for distributed system optimization based on formulation structure". *Structural and Multidisciplinary Optimization*, **39**(5), pp. 503–517.
- [5] Allison, J. T., Kokkolaras, M., and Papalambros, P. Y., 2007. "On selecting single-level formulations for complex system design optimization". *Journal of Mechanical Design*, **129**, p. 898.
- [6] DeMiguel, A.-V., and Murray, W., 2000. "An analysis of collaborative optimization methods". In Proceedings of the 8th AIAA/USAF/NASA/ISSMO symposium on multidisciplinary analysis and optimization, AIAA paper, Vol. 4720.

- [7] Balling, R., and Wilkinson, C., 1997. "Execution of multidisciplinary design optimization approaches on common test problems". *AIAA journal*, **35**(1), pp. 178–186.
- [8] Sobieszczanski-Sobieski, J., Agte, J. S., and Sandusky, R. R., 2000. "Bilevel integrated system synthesis". *AIAA journal*, **38**(1), pp. 164–172.
- [9] Kim, H. M., Michelena, N. F., Papalambros, P. Y., and Jiang, T., 2003. "Target cascading in optimal system design". *Journal of mechanical design*, **125**, p. 474.
- [10] Wang, W., Blouin, V. Y., Gardenghi, M. K., Fadel, G. M., Wiecek, M. M., and Sloop, B. C., 2013. "Cutting plane methods for analytical target cascading with augmented lagrangian coordination". *Journal of Mechanical Design*, **135**(10), 08, pp. 104502–104502.
- [11] Xiong, F., Yin, X., Chen, W., and Yang, S., 2010. "Enhanced probabilistic analytical target cascading with application to multi-scale design". *Engineering Optimization*, **42**(6), pp. 581–592.
- [12] Brown, N. F., and Olds, J. R., 2006. "Evaluation of multidisciplinary optimization techniques applied to a reusable launch vehicle". *Journal of Spacecraft and Rockets*, **43**(6), NOV-DEC, pp. 1289–1300. AIAA 43rd Aerospace Sciences Meeting and Exhibit, Reno, NV, JAN 10-13, 2005.
- [13] Lu, Y.-Y., Hu, Y.-D., Zhang, X.-L., Wu, L.-Y., and Liu, Q.-Z., 2007. "Optimum design of reverse osmosis system under different feed concentration and product specification". *Journal of membrane science*, **287**(2), pp. 219–229.
- [14] Yechiel, A., and Shevah, Y., 2012. "Optimization of energy costs for swro desalination plants". *Desalination and Water Treatment*, **46**(1-3), pp. 304–311.
- [15] Williams, C. M., Ghobeity, A., Pak, A. J., and Mitsos, A., 2012. "Simultaneous optimization of size and short-term operation for an ro plant". *Desalination*.
- [16] Sassi, K. M., and Mujtaba, I. M., 2011. "Optimal design and operation of reverse osmosis desalination process with membrane fouling". *Chemical Engineering Journal*, **171**(2), pp. 582–593.
- [17] Vince, F., Marechal, F., Aoustin, E., and Breant, P., 2008. "Multi-objective optimization of ro desalination plants". *Desalination*, **222**(1), pp. 96–118.
- [18] Kim, Y. M., Kim, S. J., Kim, Y. S., Lee, S., Kim, I. S., and Kim, J. H., 2009. "Overview of systems engineering approaches for a large-scale seawater desalination plant with a reverse osmosis network". *Desalination*, **238**(1), pp. 312–332.
- [19] Perez, R. E., Liu, H. H., and Behdinan, K., 2004. "Evaluation of multidisciplinary optimization approaches for aircraft conceptual design". In AIAA/ISSMO Multidisciplinary Analysis and Optimization Conference, Albany, NY.
- [20] De Wit, A., and van Keulen, F., 2007. "Numerical comparison of multi-level optimization techniques". In Proceedings of the 3rd AIAA multidisciplinary design optimization specialist conference, Honolulu, HI.
- [21] Honda, T., Ciucci, F., Lewis, K., and Yang, M. C., 2010. "A comparison of information passing strategies in system level modeling". In International Design Engineering Technical Conferences. Montreal, Canada.
- [22] Wolf, P. H., Sivers, S., and Monti, S., 2005. "Uf membranes for ro desalination pretreatment". *Desalination*, **182**(1), pp. 293–300.
- [23] Pearce, G., 2007. "The case for uf/mf pretreatment to ro in seawater applications". *Desalination*, **203**(1), pp. 286–295.
- [24] Bonn elye, V., Guey, L., and Del Castillo, J., 2008. "Uf/mf as ro pre-treatment: the real benefit". *Desalination*, **222**(1), pp. 59–65.
- [25] Malek, A., Hawlader, M., and Ho, J., 1996. "Design and economics of ro seawater desalination". *Desalination*, **105**(3), pp. 245–261.
- [26] Lu, Y.-y., Hu, Y.-d., Xu, D.-m., and Wu, L.-y., 2006. "Optimum design of reverse osmosis seawater desalination system considering membrane cleaning and replacing". *Journal of membrane science*, **282**(1), pp. 7–13.
- [27] Bilton, A. M., 2013. "A modular design architecture for application to community-scale photovoltaic-powered reverse osmosis systems". PhD thesis, Massachusetts Institute of Technology.
- [28] Michalek, J. J., and Papalambros, P. Y., 2006. "Bb-atc: Analytical target cascading using branch and bound for mixed integer nonlinear programming". In Proceedings of the ASME Design engineering Technical Conference, Philadelphia, PA.
- [29] Tosserams, S., Etman, L., Papalambros, P., and Rooda, J., 2006. "An augmented lagrangian relaxation for analytical target cascading using the alternating direction method of multipliers". *Structural and Multidisciplinary Optimization*, **31**(3), pp. 176–189.
- [30] Kim, H. M., Chen, W., and Wiecek, M. M., 2006. "Lagrangian coordination for enhancing the convergence of analytical target cascading". *AIAA journal*, **44**(10), pp. 2197–2207.
- [31] MATHWORKS, 2013. *Mixed Integer Optimization*.
- [32] Yi, S.-I., Shin, J.-K., and Park, G., 2008. "Comparison of mdo methods with mathematical examples". *Structural and Multidisciplinary Optimization*, **35**(5), pp. 391–402.