

## MIT Open Access Articles

*Feasibility of a Clutchless Dual-Shaft Hybrid Transmission System for Performance Applications*

The MIT Faculty has made this article openly available. **Please share** how this access benefits you. Your story matters.

**Citation:** Shah, Sahil, Victor Prost, Zachary Eubanks, Paige Reiter, Daria Bondarchuk, Yu Hua, Daniel S. Dorsch, and Amos G. Winter. "Feasibility of a Clutchless Dual-Shaft Hybrid Transmission System for Performance Applications." Volume 3: 18th International Conference on Advanced Vehicle Technologies; 13th International Conference on Design Education; 9th Frontiers in Biomedical Devices (August 21, 2016).

**As Published:** <http://dx.doi.org/10.1115/DETC2016-59955>

**Publisher:** ASME International

**Persistent URL:** <http://hdl.handle.net/1721.1/120780>

**Version:** Final published version: final published article, as it appeared in a journal, conference proceedings, or other formally published context

**Terms of Use:** Article is made available in accordance with the publisher's policy and may be subject to US copyright law. Please refer to the publisher's site for terms of use.



**DETC2016-59955**

## **FEASIBILITY OF A CLUTCHLESS DUAL-SHAFT HYBRID TRANSMISSION SYSTEM FOR PERFORMANCE APPLICATIONS**

**Sahil Shah**

**Victor Prost**

**Zackary Eubanks**

**Paige Reiter**

**Daria Bondarchuk**

**Yu Hua**

**Daniel S. Dorsch**

**Amos G. Winter, V**

Massachusetts Institute of Technology  
Department of Mechanical Engineering  
Cambridge, Massachusetts, 02139, U.S.A.

### **ABSTRACT**

*A novel hybrid-electric transmission concept was sought that yields higher acceleration and smoother gear-shifts compared to existing dual-clutch systems while improving the energy efficiency of the vehicle. After evaluating a range of strategies, the elimination of the clutch was identified as a viable method for reducing the vehicle's effective inertia and viscous losses. The proposed architecture implements a single electric motor, and two separate shafts for odd and even gears, to replace the functions of a clutch. High acceleration rates can be achieved using the electric motor when launching the vehicle. Furthermore, the torque from the electric motor (EM) and internal combustion engine (ICE) can be simultaneously delivered through the two shafts to sustain this high acceleration. A 0 to 100 km/hr time of 3.18 s was simulated for a 1600 kg vehicle using a 180 kW EM and 425 kW ICE. In addition, the EM can be used to match the speeds of consecutive gears on the two shafts to reduce jerk while shifting. Shift durations were found to vary between 0.2 and 0.9 s using this strategy. Other benefits include regenerative braking and the removal of the reverse gear since the EM can rotate in either direction. It was also found that the vehicle can be operated on only electric power in urban settings - represented by the NEDC driving cycle - if the battery is recharged through regenerative braking, and by the ICE the vehicle is stopped.*

### **1. INTRODUCTION**

#### **1.1. Motivation**

An automobile's transmission serves the critical role of connecting the power source to the wheels. Power from an internal combustion engine (ICE) or electric motor (EM) is delivered to the wheels through a series of gears and shafts to propel the vehicle. The configuration of the transmission system influences aspects of vehicle performance which include acceleration rates and maximum speed. Most modern transmission systems are configured to allow the selection of different gear ratios to improve performance and efficiency across a wide range of vehicle speeds.

Since the early 20<sup>th</sup> century, most passenger vehicles have used an ICE as the principal power source[1]. More recent concerns about the impact of greenhouse gas emissions and our limited supply of fossil fuels has prompted many automobile manufacturers to pursue more energy-efficient electric vehicle (EV) and hybrid-electric vehicle (HEV) technologies. This paper will focus primarily on HEVs.

The greenhouse gas emissions in the transportation sector have doubled since 1970, contributing approximately 23% of all energy-related CO<sub>2</sub> emissions[2]. A 40% increase in atmospheric CO<sub>2</sub> concentrations since the beginning of the industrial revolution has been a primary driver of global climate change [3]. In response to this challenge, many governments have begun to regulate fuel efficiency and emissions for new automobiles. The Corporate Average Fuel Economy (CAFE) initiative, enacted by the United States Congress in 1975, will give financial penalties to auto manufacturers whose average new vehicle fuel efficiency performance falls below an increasingly strict threshold. For example, average fleet-wide

fuel economy for passenger cars and light trucks is required to be at least 40.3 mpg by model year 2021[4]. Similarly, the EU is imposing emissions requirements of increasing severity, limiting fleet average CO<sub>2</sub> emissions to 95g per kilometer by 2021[5].

In addition to the reduced emissions and improved fuel efficiency associated with HEVs, several supercar manufacturers have demonstrated the impressive performance that can be achieved through hybrid technologies. In these vehicles, the primary performance advantage that is imparted through the addition of an electric motor is the high torque that can be applied at low speeds. This allows for high acceleration from a stop, demonstrating one way that utilizing a hybrid transmission configuration can improve performance characteristics.

## 1.2. Hybrid Vehicles

The popularity of hybrid vehicles has increased substantially in the past decade. The market has been dominated by efficiency-focused passenger cars, such as the Toyota Prius [6]. The integration of multiple power sources, such as an ICE and EM, into a transmission architecture has been accomplished through a number of different strategies, each of which has its own advantages and disadvantages. The most prominent strategies that have been implemented use parallel architectures, series architectures, global hybrid cooperation and through-the-road (TTR) systems, or power-split devices (PSDs).

In parallel hybrid architectures, the ICE and an EM are mechanically coupled and work together to drive the car. Typically, the electronic control unit (ECU) assesses the power requirement that corresponds to driver control inputs and allocates the most-efficient combination of ICE and EM power. One primary advantage of these architectures is that they allow the ICE to charge the batteries while the vehicle is stationary. However, these systems can be complex and the mass of the required components can counteract the efficiency improvements [7].

Series hybrid architectures, on the other hand, couple the ICE directly to an electrical generator which can be used to either directly power an EM or to recharge a battery pack. In this configuration, the ICE can never directly power the vehicle. The series architecture provides the advantage that the ICE can always operate at its maximum efficiency, and the entire system can be packaged into a much smaller space than parallel systems. As a result of the multiple energy conversions, there are significant reductions in overall efficiency, especially during highway driving. Series hybrids been shown to be effective and easy to control for urban stop-and-go applications [8].

Global hybrid cooperation or also called “two mode hybrid architecture”, is a technology that includes three planetary gear sets, one ICE and two EMs to enable the system to switch from a series configuration to a parallel one. This systems tries to make the most of the two previous architectures, but it needs a large amount of planetary gear sets and two EMs which increases the inertia and that does not perform well at high speed.

TTR systems take a different approach by driving each axle from a different power source. For example, an ICE can

drive the rear wheels, while an EM drives the front wheels. In this configuration, the ICE and the EM are not mechanically linked but are instead linked by their common contact with the road. This lack of direct coupling means that this system is relatively easy to incorporate into a vehicle, but a complex control system is required to operate both power sources optimally. Further, recharging the battery pack in a TTR system is only possible when the vehicle is moving, and the energy conversion between the ICE and generator is inefficient [9].

Another class of hybrids relies on power-split devices (PSDs), such as planetary gear sets, to transmit the power from both an ICE and an EM into a single output or to recharge the battery by turning the EM with the ICE. Using this method, such systems are able to incorporate some of the best features of both parallel and series hybrids. These systems, however, are only efficient within a small range of speeds, which limits their applicability to performance vehicles [8].

## 1.3. Objective

This project was proposed, motivated, and sponsored through a partnership between a high-performance vehicle design and manufacturing company and Course 2.76 (Global Engineering) at MIT. The objective was to develop a hybrid architecture to increase the fuel efficiency and lower the greenhouse gas emissions of an existing performance vehicle without sacrificing its high-performance operation. It was important that the added hybrid components did not negatively impact the driver experience when compared to the existing, non-hybrid vehicle. TABLE 1 summarizes the performance objectives for the project which were driven by vehicle manufacturer.

**TABLE 1:** Summary of performance objectives

Criteria	Target
Acceleration (0 to 100 km/hr)	≤ 3.2 sec
Top Speed	≥ 320 km/hr
Emissions Requirements	< 275 g CO <sub>2</sub> /km
Architecture Requirements	Only 1 EM
User Experience Requirements	Smooth shifting Conserve engine scream

## 2. STRATEGIES CONSIDERED

As demonstrated by the range of hybrid options available today, an EM can serve in different capacities. Instead of analyzing the merits of each individual system, our approach was to analyze a torque-speed curve for an ICE driven vehicle and identify key regions where improvements could be made using the EM. FIGURE 1 provides the assumed torque curve for a 7-speed rear wheel drive performance car [10]. Each curve represents a different gear ratio, with a maximum speed in first gear of 77 km/hr at the engine’s redline speed of 9000 RPM.

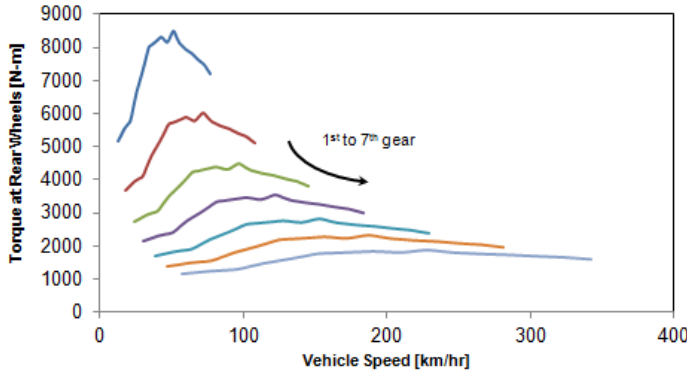

FIGURE 1: Rear wheel torque against speed for 425 kW ICE

To further understand the factors limiting a vehicle's performance, the friction limit of the tires, aerodynamic drag, and rolling resistance were also considered. Then the maximum acceleration ( $a$ ) that can be achieved at any given velocity ( $V$ ) is given by

$$a = \frac{\min(T_{fric}, T_{wheel})}{m_{eff}} - F_{rr} - F_{aero}, \quad I$$

where  $T_{wheel}$  is the driving torque at the rear wheels from FIGURE 1,  $T_{fric}$  is the friction limit of the tires, and  $m_{eff}$  is the effective mass of the vehicle accounting for both the rotational inertia of the transmission system and the linear inertia of the vehicle. The friction limit of the tire is a function of the tire's coefficient of static friction ( $\mu$ ) and the weight acting upon it ( $m_{car}g + F_{down}$ ).

$$T_{fric} = \mu(m_{car}g + F_{trans} + F_{down}). \quad II$$

The rolling resistance ( $F_{rr}$ ) and the aerodynamic drag ( $F_{aero}$ ) are calculated using Equations III and IV respectively

$$F_{rr} = (m_{car}g + F_{down})C_{RR} \quad III$$

$$F_{aero} = \frac{1}{2} C_{aero} \rho_{air} A_{front} V^2, \quad IV$$

where the rolling resistance coefficient ( $C_{RR}$ ), the fraction of the vehicle weight considering weight transfer due to acceleration ( $m_{car}g + F_{trans}$ ), and aerodynamic downforce ( $F_{down}$ ) acting on the tire govern its rolling resistance. The coefficient of drag ( $C_{aero}$ ), air density ( $\rho_{air}$ ), and frontal area ( $A_{front}$ ) are used to calculate the aerodynamic drag.

FIGURE 2 plots the maximum torque at any given vehicle speed. It is divided into two regions. At speeds below 110 km/hr, the vehicle is friction-limited. In this range, torque exceeding the friction limit of the tires would result in slipping. At higher speeds, the torque from the engine dictates the maximum acceleration, as the available torque does not exceed the friction limit of the tires.

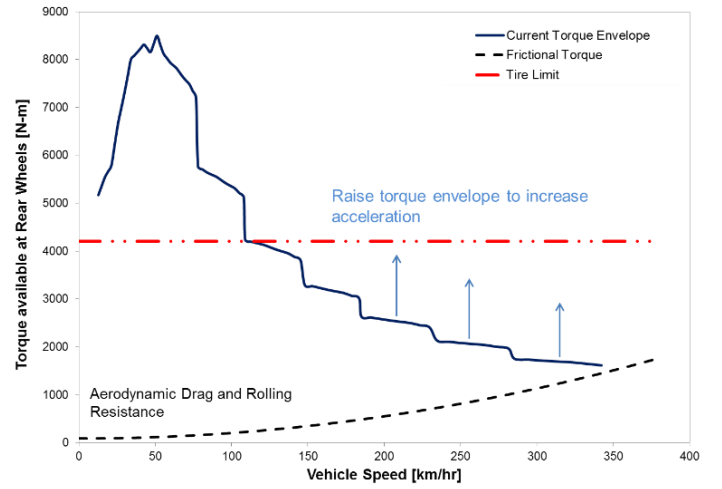

FIGURE 2: Tire friction limit and drag torque plotted against the vehicle speed

From FIGURE 2, it is evident that the capacity to accelerate at high speeds can be improved if an EM is used to provide additional torque through the full range of vehicle speeds. Architectures have been proposed which implement a planetary gear set and two geared shafts to couple the torque provided by both the ICE and EM [11–14]. However, the time taken to shift between gears is in the range of 0.6 to 1.2 sec [15], thereby making them too slow for performance applications where current shift times are on the order of 0.1 sec [16]. A shorter time is desired to minimize the decrease in vehicle speed during shifting.

Alternatively, the EM can be used as the primary mover of the vehicle with the ICE serving as a generator. However, such an architecture did not meet the performance requirements listed in TABLE 1 since the driving experience would be compromised by losing the engine roar. Furthermore, an EM and power system capable of acceleration to 100 km/hr at a rate that is comparable to existing performance cars are estimated to weigh approximately 163 kg, or 10% of the baseline vehicle weight (See Appendix A). Given the desire for minimal weight, such a system was considered too heavy to incorporate in a performance car. It followed that the EM could only be used as the primary power source at speeds lower than 100 km/hr.

Given that it is not feasible to use the EM to supply torque through all vehicle speeds due to weight considerations, the chosen strategy uses the EM for low-speed acceleration and driving while the ICE is engaged at higher speeds.

EMs provide their maximum torque at low speed, thereby making them conducive to this application. It can be geared to achieve maximum acceleration at low speeds by ensuring that the torque output meets the tire friction limit. By implementing an EM at low speeds, the gear ratios for the ICE can then be optimized to improve torque availability at high speeds without exceeding the tire friction limit (see FIGURE 4).

From Equation I, it is also evident that acceleration can be improved by reducing the effective inertia of the vehicle. This can be accomplished by reducing the number of large rotational elements, such as gears and the clutch, from the transmission system. The removal of the clutch yields additional efficiency benefits since 20-25% of a single-clutch transmission's losses are incurred due to viscous losses at the clutch [17]. Therefore,

another objective of the hybrid transmission architecture proposed in this paper is to eliminate the clutch and implement an EM to yield performance benefits without increasing the net weight of the system.

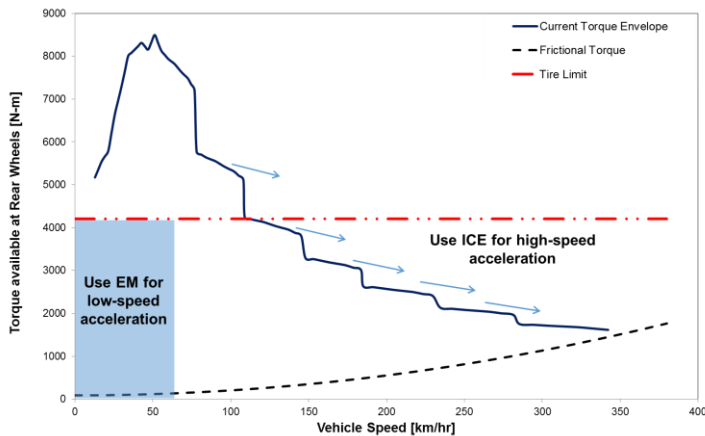

FIGURE 3: Proposed architecture uses EM for low-speed acceleration and optimizes ICE gear ratios for improved high-speed acceleration.

### 3. CONCEPT

#### 3.1. Overview

The proposed hybrid transmission architecture blends an EM's high efficiency with an ICE's ability to deliver high performance. Key elements of this architecture include two power sources, dual shafts, and no clutch (FIGURE 4).

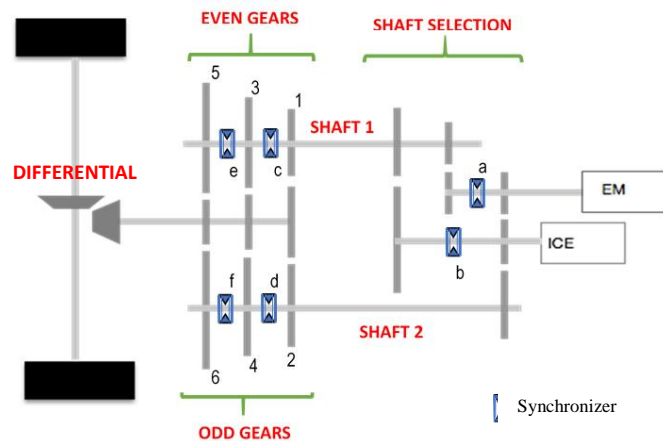

FIGURE 4: Overview of the proposed hybrid architecture. The EM and/or the ICE can be engaged and used to drive either Shaft 1 or Shaft 2. Gears positioned next to synchronizers (a - f) are idlers and gears without synchronizers are fixed to the shaft. In addition, the EM can be used to start the ICE, and the ICE can be used to recharge the battery through the EM.

Inspired by a dual-clutch transmission (DCT) system, this architecture has two geared shafts at the output. At the input, the EM and the ICE both provide power to the transmission. Each power source can be paired with either shaft using synchronizers a and b. The primary benefits of this arrangement include:

- **Quick launch:** The power from both the EM and ICE can be delivered to the output to provide high acceleration rates.

- **Speed-matching:** While the ICE transmits power to the wheels through one shaft, the EM is used to rotate the other shaft to match the speed of the consecutive gear. Then, the ICE can be disengaged from one shaft and engaged to the other to provide a fast shift.
- **Torque-filling between gears:** After the ICE is disengaged from one shaft, but before it is engaged to the other, the EM can provide torque to the rear wheels. This function minimizes the jerk and maintains power to the wheel during gear shifting, enabling the car to continue accelerating.
- **Efficient city driving:** The more efficient EM is used to drive the vehicle at low speeds in both the forward and reverse directions. The ICE can be operated at its most efficient RPM range to recharge the battery when required.

In a traditional transmission, the primary function of a clutch is to disconnect the source of torque from the transmission so that gear changes can be made without damaging the synchronizers' teeth. Here, this function is handled by the car's ECU through speed-matching. This technique is based on controlling the speed of the rotating shafts and gears to engage synchronizers when speeds are matched to ensure that engaging teeth are not damaged. Detailed walkthroughs of this shifting strategy are provided in Sections 3.2.2 through 3.2.6.

The removal of the clutch and reverse gear (and associated idler), and the addition of an EM and batteries, did not reduce the total weight of the transmission (see Appendix B). However, as shown in Section 3.2.1, the addition of torque at low speeds and the reduction in the rotational inertia of the transmission provided an acceleration benefit when launching the vehicle.

#### 3.2. Modes

##### 3.2.1. Launch in Performance Mode

The time to accelerate from standstill to 100 km/hr is an important measure of a vehicle's performance. In order to launch the car using a traditional transmission, the engine is first revved at standstill with the clutch disengaged. When the clutch is suddenly engaged, kinetic energy from the engine's flywheel is used to accelerate the vehicle.

In the proposed concept, the launch sequence utilizes the EM for independently accelerating the vehicle to 22 km/hr and engages the ICE thereafter to continue accelerating to the target 100 km/hr speed. The sequence of operations are outlined below and illustrated in FIGURE 5.

1. Synchro (c) is first used to engage the first gear to the output shaft. The EM is engaged to Shaft 1 using Synchro (a). The EM begins to accelerate the vehicle while the ICE idles at a fixed speed.
2. When the speed of Shaft 1 matches the speed of the ICE (accounting also for the gearing), Synchro (b) is engaged. Now, both the ICE and the EM drive Shaft 1.
3. As the maximum speed of the EM is approached, it does not make significant contributions to total torque in first gear. Subsequently, Synchro (a) is used to disengage the EM. The ICE continues to independently accelerate the vehicle beyond 112 km/hr.

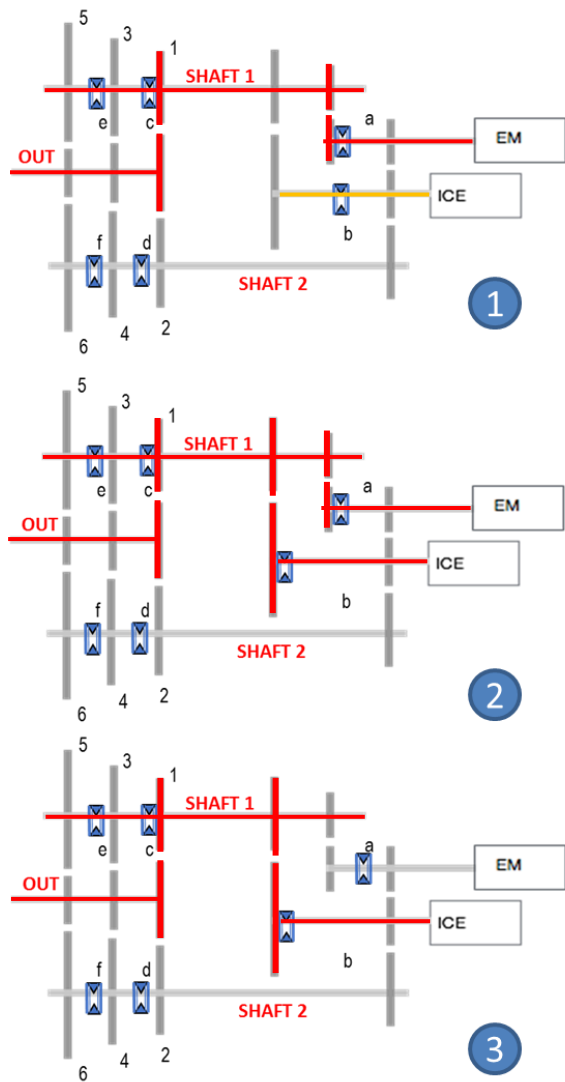

**FIGURE 5:** Launch sequence. Elements that are transmitting power are highlighted in red. The yellow shaft is rotated by the ICE, but is not delivering power.

The advantages of this system are identified by examining the wheel torque versus vehicle speed curve in FIGURE 6 which was simulated in MATLAB. The torque-speed data for the Brusa HSM1 180 kW Hybrid Motor [18] was used for this analysis with the vehicle parameters provided by the performance car company.

The design harnesses the ability of the EM to produce the highest torque at low speeds. The EM is geared to maximize the torque that can be delivered to the tires without causing them to slip. In this speed range below 22 km/hr, the ICE provides low levels of torque and therefore remains disengaged. However, during this phase, the ICE can be revved to preserve the experience of launching a supercar.

Once both power sources are engaged to Shaft 1, the ECU regulates EM torque to continue providing maximum acceleration while avoiding tire slip.

Gear ratios for the EM and ICE are optimized to eliminate the need for shifting between 0 and 100 km/hr. For maximum acceleration, the gear ratios for the EM and ICE were estimated to be 2.80 and 1.75, respectively, with a final drive gear ratio of

5 [19]. Acceleration from 0 to 100 km/hr was estimated to take 3.18 s in this simulation for a vehicle weighing approximately 1600 kg.

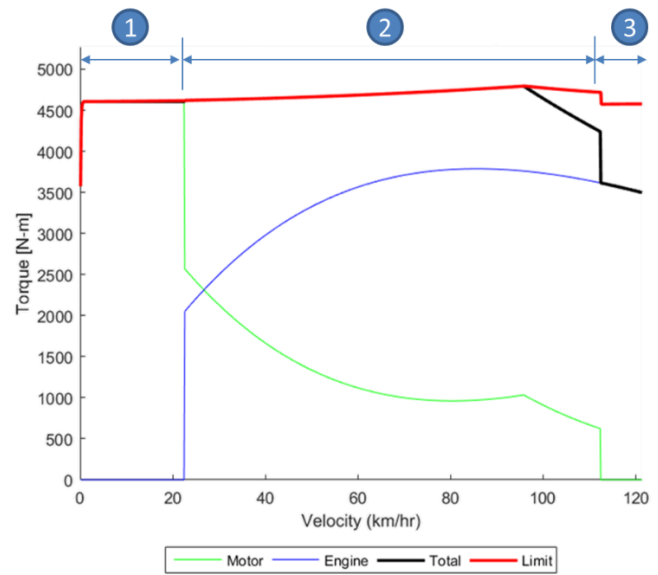

**FIGURE 6:** Simulated torque at the rear wheels during launch. The friction limit gradually increases with speed because the normal force acting on the rear tires increases due to aerodynamic downforce.

### 3.2.2. Low-Speed Upshifting (Torque-Filling)

During regular driving situations, the upshifting are performed around 2000-3000 RPM which is considered “low-speed” in our case. The sequence of operations for smoothly upshifting from first gear to second gear is listed below. The same procedure can also be applied when shifting from second gear to third gear (see FIGURE 7).

1. The ICE drives the vehicle through Shaft 1 with Synchro (b) and Synchro (c) engaged while the EM idles.
2. Once the ECU receives signal to upshift, the EM is engaged to Shaft 2 using Synchro (a).
3. The EM increases the speed of Shaft 2 to match that Gear 2 which is spinning with the output shaft.
4. Once the speed is matched, the ECU locks Synchro (d) to engage Gear 2 to Shaft 2.
5. The ECU adjusts the throttle of the ICE to reduce its torque output. At the same time, the EM’s torque output is adjusted accordingly to maintain a constant total torque output.
6. When the ICE’s torque output is nearly zero, the ECU unlocks Synchro (c) to disengage the ICE from Shaft 1. Here, the EM is momentarily driving the vehicle to torque-fill between gears in order to minimize jerk.
7. Once disengaged, the ICE speed decreases due to friction and pumping losses.
8. Once the ICE is speed-matched to Shaft 2, the ECU shifts Synchro (b) to the right to engage the ICE to Shaft 2.
9. Finally, the ECU unloads the EM and disengages it from Shaft 2, leaving the ICE driving the car through second gear.

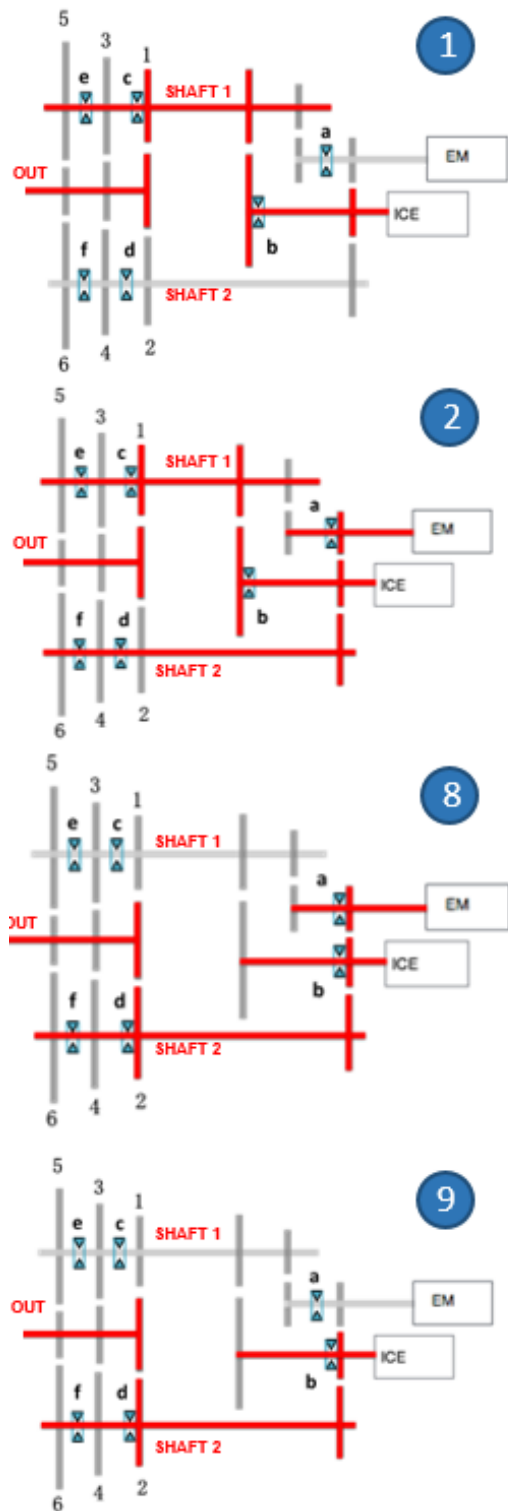

FIGURE 7: Low-speed upshift sequence

The total time for this upshifting procedure is an estimated 1.1 sec (see Appendix C), of which the largest contributor is the time required to decelerate the ICE (0.9 s). Instead of relying on losses alone to slow down the ICE, a braking device can be implemented to produce higher deceleration. Then, the shift time is expected to reduce to approximately 0.2 s.

### 3.2.3. High-Speed Upshifting (Speed-Matching)

Torque-filling is not achieved at high vehicle velocities because the EM has poor torque performance at high RPM. However, at these speeds, the speed lost during shifting is a small fraction of the original speed. Hence, jerk is not critical. Instead, the proposed architecture uses the EM to directly speed-match the ICE when shifting at high speeds (see FIGURE 8).

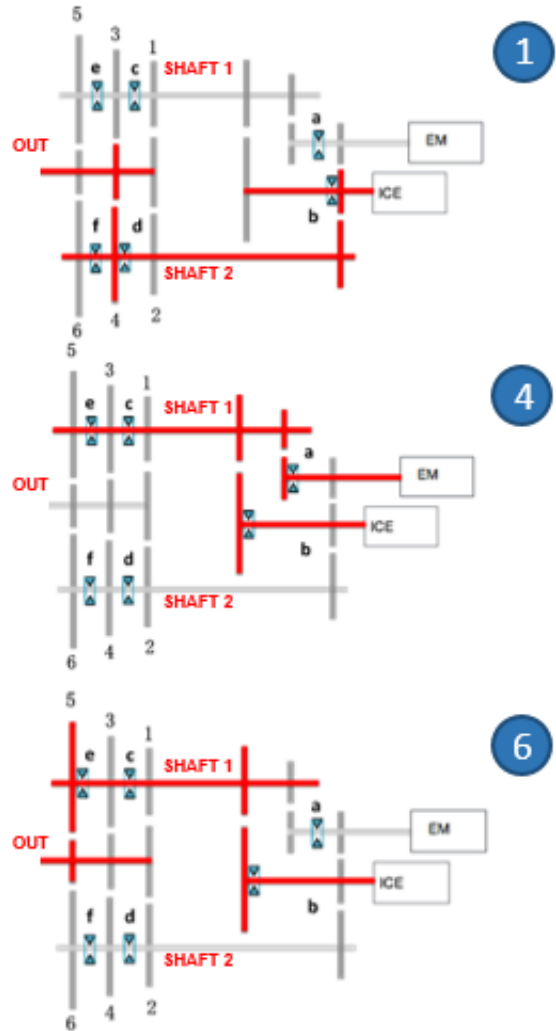

FIGURE 8: High-speed upshift sequence

1. The ICE drives the vehicle through Shaft 2 with Synchro (b) and Synchro (d) engaged while the EM idles.
2. The ECU first speeds up the EM with Shaft 1 and simultaneously adjusts the throttle of the ICE.
3. When the ICE output torque is zeroed, the ECU unlocks Synchro (d) and (b) to disengage the ICE from gear 4 and Shaft 2.
4. When the EM's speed matches that of the ICE, the ECU locks Synchro (b), engaging the ICE on Shaft 1 with the EM.
5. The torque of the EM is used to reduce the rotational speed of the ICE.

- Once the ICE's speed matches that of gear 5, the ECU shifts Synchro (e) to engage gear 5 and unloads the EM by shifting Synchro (a) to the neutral position.

Since the torque output from the EM is directly used to decelerate the ICE, the time to perform this upshift is reduced to 0.3 s as compared to the former case (see Appendix C).

### 3.2.4. Low-Speed Downshifting (Torque-Filling)

There are two main reasons to downshift. The obvious one is for the purpose of decelerating or braking. The other is to accelerate and provide more torque to the wheels by changing the gearing.

The downshifting procedure in the decelerating or braking scenario from second to first gear is outlined below and illustrated in FIGURE 9. A similar procedure is applied to downshift from fourth to third gear and from third to second gear.

- The ICE drives the vehicle through Shaft 2 with Synchro (b) and Synchro (d) engaged while the EM idles.
- When the user decides to downshift, the ECU locks the EM to Shaft 1 through Synchro (a).
- The EM is used to increase the speed of Shaft 1 to match Gear 1.
- When the speeds are matched, the ECU engages Gear 1 to Shaft 1 using Synchro (c). The EM and the ICE are now running the car through two different shafts.
- The ECU then unloads the ICE and shifts the load to the EM.
- When the torque load on the ICE is close to zero, the ECU disengages Synchro (d) and (b) so that the ICE runs freely. Meanwhile, the EM drives the vehicle through first gear (torque-filling for engine braking torque).
- The ECU increases the speed of the ICE to match the speed of the first gear while the vehicle decelerates.
- When the speeds are matched, the ECU engages the ICE on Shaft 1 through Synchro (b). Then, both ICE and EM drive the vehicle through first gear.
- The ECU loads the ICE while unloading the EM. Eventually, the EM is disengaged using Synchro (a), and the ICE is left driving the car in first gear.

The time to perform this downshifting procedure is 0.2s (see Appendix C). The limiting factor for this downshifting speed is the rate at which the EM can speed Shaft 1 up to the speed of Gear 1.

In case the user wants to downshift to accelerate the car further and provide more torque to the wheels, the system would react differently. By monitoring the gas pedal and the ICE speed, the driver's desire to accelerate could be identified. Rather than downshifting, the EM would be engaged and used to supply additional torque through either shaft, leaving the ICE in second gear. Taking an estimated 0.1 s to engage the EM, this approach would be faster than downshifting to accelerate the car.

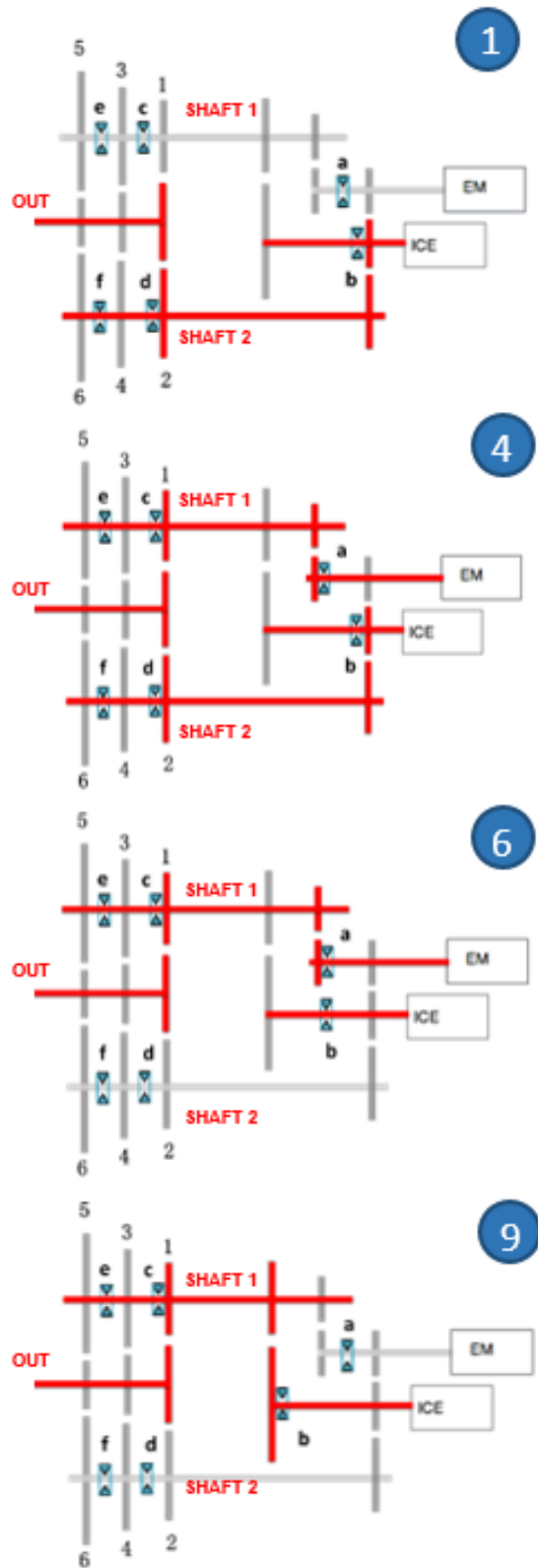

FIGURE 9: Downshift sequence and low speeds



### 3.2.5. High-Speed Downshifting (Speed-Matching)

The downshifting procedure from fifth gear to fourth gear is outlined below. In this high speed procedure, the EM is used to speed up the ICE match the speed of the fourth gear in order to facilitate engagement.

1. The ICE drives the vehicle through Shaft 1 with Synchro (b) and Synchro (e) engaged while the EM idles.
2. When the user decides to downshift, the ECU unloads the ICE and disengages fifth gear by shifting Synchro (e) and (b). At same time, the ECU locks the EM to shaft 2 and use the EM to speed match shaft 2 to the ICE.
3. When the speeds are matched, the ECU engages Synchro (b) to lock the EM to the ICE.
4. Then the EM is used to accelerate the ICE to match the speed of the fourth gear.
5. Subsequently, the ECU engages Synchro (d) to engage the ICE in fourth gear and then disengages the EM through Synchro (a) leaving the ICE driving.

This downshifting procedure is estimated to take 0.2 s (see Appendix C). The limiting factor for the downshifting speed is the time required to accelerate the EM to match the speed of the ICE.

### 3.2.6. City Driving

#### 3.2.6.1. Battery Selection

The main requirements for the batteries in a high-performance hybrid car are high energy density, high power discharge rate, and low weight. In addition, the batteries need to charge quickly and have adequate safety features. Compared to most heavy-duty rechargeable batteries, lithium-ion batteries have a relatively high energy density. For this reason, the Panasonic Li-Ion battery NCR18650A [21] was selected for the design. The calculations were performed for the case where all stored energy is used for driving. The chosen battery set consists of 331 batteries cells configured to achieve the target voltage and current ratings. The battery set parameters are summarized in TABLE 2.

TABLE 2: Required battery set parameters

Parameter	Units	Value
Nominal Capacity	[kW-h]	3.07
Total Nominal Voltage	[V]	360
Mass of Battery Set	[kg]	15.6
Total Max Discharge Current	[Amp]	1433
Total Max Power	[kW]	420
Approximate Total Mass with Cooling System and Packaging	[kg]	76

#### 3.2.6.2. City Driving Validation

Since the proposed architecture relies on the EM to start from a standstill, it is important that the system fulfills the demands of daily city driving without depleting the energy in the batteries. The NEDC (New European Driving Cycle) [22] was simulated to represent the typical usage of a vehicle during urban driving. This cycle consists of four repeated ECE-15 urban driving cycles (UDC) and one extra-urban driving cycle (EUDC).

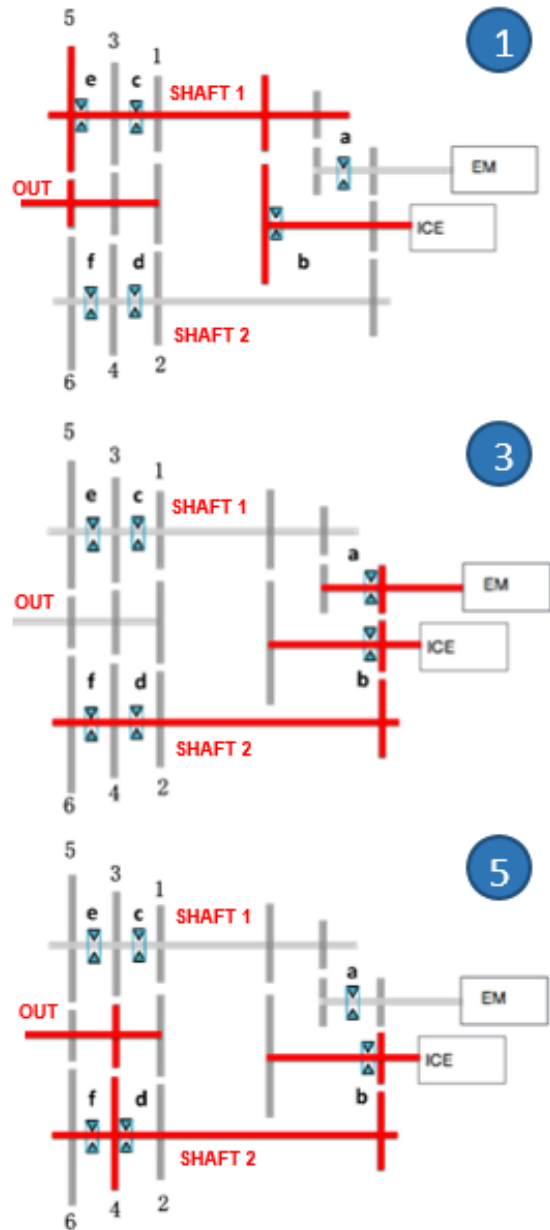

FIGURE 10: Downshifting sequence at high speeds

Key parameters characterizing the NEDC are represented in TABLE 3.

TABLE 3: Characteristics of NEDC

Characteristic	Unit	ECE-15	EUDC
Distance	km	0.9941	6.9549
Total Time	sec	195	400
Idle (Standing) Time	sec	57	39
Average Speed (Including Stops)	km/hr	18.35	62.59
Average Driving Speed (Excluding Stops)	km/hr	18.35	62.59
Maximum Speed	km/hr	50	120
Average Acceleration	m/s <sup>2</sup>	0.599	0.354
Maximum Acceleration	m/s <sup>2</sup>	1.042	0.833

Efficient operation can be achieved by using the EM as the power source during both acceleration and constant-speed motion for urban driving. For each step in the cycle, the energy required to accelerate and overcome rolling and air resistance was depleted from the initial battery level.

Energy was gained through regenerative braking when the vehicle was decelerated to a stop. Assuming a battery-to-wheel conversion efficiency of 80%, and that the energy must make a full loop back to the battery, a net efficiency of 64% ( $0.8^2$ ) was assumed for regeneration [23].

When the battery charge is low, power generated by the ICE can also be used to recharge the battery. In FIGURE 11, it is conservatively assumed that the ICE is operated at the minimum speed of 1500 RPM and produces 8.0 kW when the vehicle is at a stop. Transmission of power from the ICE to EM was assumed to be 60% efficient.

The simulation of the battery charge level through the NEDC is provided in FIGURE 11. A net increase in charge level was achieved through the cycle, demonstrating that the proposed architecture is capable of handling typical city driving functions without fully discharging the battery.

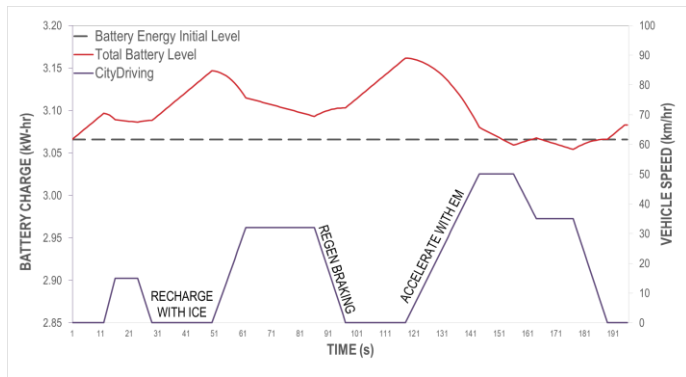

FIGURE 11: Battery level during ECE-15 urban driving cycle

In this simulation, it was assumed that the ICE is operated at its minimum speed of 1500 RPM. However, recharging can also be performed in the range of the ICE speeds that provides the highest efficiency or lowest emissions.

### 3.3. Packaging

The gearbox was designed meet the top speed and initial acceleration requirements. This led to the selection of 1.75 for the first gear ratio, 0.69 for the sixth gear ratio assuming a final drive gear ratio of 5 and a 1.6 gear ratio between the EM and the ICE. The ratios for gears two through five were then selected to maximize useful (no-slip) torque output.

TABLE 4: Gear ratios after optimization

Gear Number	Gear Ratio
1	1.75
2	1.36
3	1.16
4	0.95
5	0.82
6	0.69

The gear ratios were also geometrically constrained to ensure that the center-to-center distance from each gear on one shaft to the corresponding gear on the output shaft remained constant. Then, the total inertia of the gear set was minimized using MATLAB to produce the selection in TABLE 4.

### 3.4. Performance Evaluation

TABLE 5 demonstrates that the proposed dual-shaft hybrid architecture satisfies the key design requirements. The acceleration rate, which was simulated in MATLAB (see Section 3.2.1) indicated a performance benefit from the proposed hybrid architecture. Furthermore, the top-speed is not expected to be affected if the same ICE is implemented since the EM provides negligible torque at high speeds.

This feasibility study did not characterize the emissions for hybrid operation. However, we surmise that since the ICE can be operated in its optimum range for recharging in urban driving conditions (see Section 3.2.6), the emissions should decrease.

Lastly, the proposed architecture satisfied the requirements related to the user experience. As indicated in Section 3.2.1, the ICE can be revved while the EM is being used to propel the vehicle to preserve the engine scream. Furthermore, smoother shifting is obtained at low speeds since the EM can be used to torque-fill while the ICE is shifting gears (see Sections 3.2.2 and 3.2.4).

TABLE 5: Target and calculated values for key design criteria

Criteria	Target	Calculated
Acceleration (0-100 km/hr)	$\leq 3.2$ sec	3.18 sec
Top Speed	$\geq 320$ km/hr	320 km/hr
Emissions Requirements	$< 275$ g CO <sub>2</sub> /km	ICE is operated in optimum range to reduce emissions
Architecture Requirements	Only 1 EM	Only 1 EM
User Experience Requirements	Smooth shifting, Conserve engine scream	Minimal jerk in low gears, Engine scream is maintained

## 4. PROTOTYPE

A physical prototype was developed to demonstrate the launch and shifting operations illustrated in Section 3.2. It was constructed using select shafts, gears, and synchronizers from three identical 1999 Honda Civic transmissions mounted on a 1.2 m long custom aluminum and Delrin test bed. Constrained by the parts that were available, the prototype incorporated an idler shaft as a link between the two motor input shafts as indicated by the schematic in FIGURE 12.

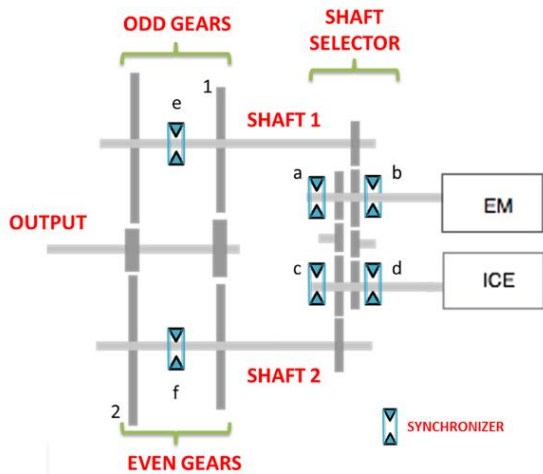

**FIGURE 12:** Schematic showing the components implemented in the physical prototype

Only four out of the six gears were implemented in the prototype as this allowed for adequate demonstration of the launch, upshift, and downshift functions. The ICE in the model was replaced by an electric motor for simplicity of control and a reduced footprint. Therefore, both input shafts were powered by the electric drives from two Craftsman C3 drills [20], and four 5 V servos were used to shift the synchronizers as illustrated in FIGURE 13 powered by a DC power supply (10A, 30V) and controlled by an Arduino Mega micro-controller, a custom speed control circuit, and two Hall-effect sensors.

The prototype was successfully used to demonstrate the launch sequence as well as upshifting and downshifting between the first and second gear.

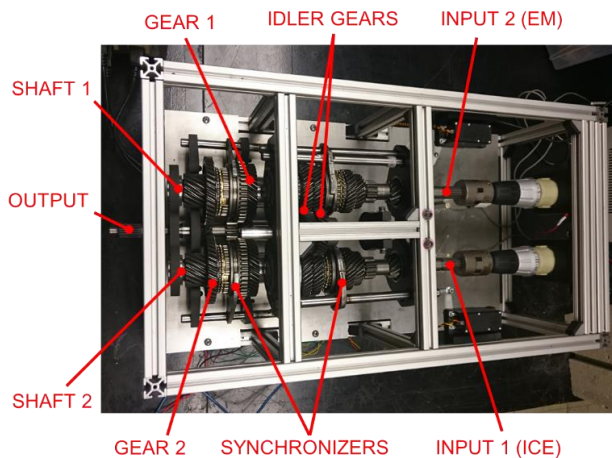

**FIGURE 13:** Top-view photograph of the prototype used to validate the proposed architecture

## 5. CONCLUSION

The proposed hybrid transmission architecture features a dual-shaft, clutchless transmission which utilizes an EM in unison with an ICE to maintain high-performance operation while facilitating more efficient driving in urban settings. The design uses an EM to perform the traditional functions of a clutch, thereby allowing the addition of torque while reducing the inertia of the transmission system. The addition of the EM in the proposed configuration provides performance benefits such as high rates of initial acceleration and torque-filling during gear changes at low speeds.

## ACKNOWLEDGEMENTS

This work was performed for the 2.76 Global Engineering Class and was funded by the Tata Center for Technology and Design at the Massachusetts Institute of Technology. We would like to thank Andrea Canaparo, Fabrizio Favaretto, and Luca Splendi for providing their insight and feedback throughout the design process.

## REFERENCES

- [1] Ehsani, M., Gao, Y., and Emadi, A., 2010, *Modern electric, hybrid electric, and fuel cell vehicles: fundamentals, theory, and design.*, Boca Raton : CRC Press, c2010.
- [2] Edenhofer, O., R. Pichs-Madruga, Y. Sokona, E. Farahani, S. Kadner, K. Seyboth, A. Adler, I. Baum, S. Brunner, P. Eickemeier, B. Kriemann, J. Savolainen, S. Schlömer, C. von Stechow, T. Z. and J. C. M. (eds. 2014, "IPCC, 2014: Climate Change 2014: Mitigation of Climate Change. Contribution of Working Group III to the Fifth Assessment Report of the Intergovernmental Panel on Climate Change."
- [3] US EPA, C. C. D., "Causes of Climate Change."
- [4] "Corporate Average Fuel Economy (CAFE) Standards | Department of Transportation."
- [5] "Reducing CO2 emissions from passenger cars - European Commission.
- [6] "Alternative Fuels Data Center: Maps and Data."
- [7] Fan, J., Zhang, J., and Shen, T., 2015, "Map-Based Power-Split Strategy Design with Predictive Performance Optimization for Parallel Hybrid Electric Vehicles," *Energies*, **8**(9), pp. 9946–9968.
- [8] Wu, G., Zhang, X., and Dong, Z., 2015, "Powertrain architectures of electrified vehicles: Review, classification and comparison," *J. Franklin Inst.*, **352**(2), pp. 425–448.
- [9] Zulkifli, S. A., Mohd, S., Saad, N. B., and Aziz, A. R. A., 2014, "Impact of Motor Size & Efficiency on Acceleration, Fuel Consumption & Emissions of Split-Axle Through-the-Road Parallel Hybrid Electric Vehicle," *Appl. Mech. Mater.*, **663**, pp. 498–503.
- [10] Fabspeed Motorsport, "Dynojet Research - 2010 Ferrari 458 Stock" [Online]. Available: <http://mbworld.org/forums/off-topic/438761-torque-vs-rpm.html>. [Accessed: 22-Nov-2015].
- [11] Yoon, Y.-S., Kim, S. J., and Kim, K.-S., 2013, "Conceptual design of economic hybrid vehicle system using clutchless geared smart transmission," *Int. J. Automot. Technol.*, **14**(5), pp. 779–784.
- [12] Mashadi, B., and Emadi, S. A. M., 2010, "Dual-Mode Power-Split Transmission for Hybrid Electric Vehicles," *IEEE Trans. Veh. Technol.*, **59**(7), pp. 3223–3232.
- [13] Lee, H., Sul, S., Cho, H., and Lee, J., 2000, "Advanced Gear-Shifting and Clutching Strategy for a Parallel-Hybrid Vehicle," *Ind. Appl. Mag. IEEE*, **6**(6), pp. 26–32.
- [14] Chen, L., Zhu, F., Zhang, M., Huo, Y., Yin, C., and Peng, H., 2011, "Design and analysis of an electrical variable transmission for a series-parallel hybrid electric vehicle," *IEEE Trans. Veh. Technol.*, **60**(5), pp. 2354–2363.
- [15] Kim, S. J., Song, C., Kim, K.-S., and Yoon, Y.-S., 2014, "Analysis of the shifting behavior of a novel clutchless

geared smart transmission,” *Int. J. Automot. Technol.*, **15**(1), pp. 125–134.

- [16] Tan, P., 2006, “VW phases out automatics; makes way for DSG” [Online]. Available: <http://paultan.org/2006/06/26/vw-phases-out-automatics-makes-way-for-dsg/>. [Accessed: 22-Nov-2015].
- [17] Pratte, D., 2010, “Drivetrain Power Loss - The 15%” [Online]. Available: <http://www.superstreetonline.com/how-to/engine/modp-1005-drivetrain-power-loss/>. [Accessed: 22-Nov-2015].
- [18] BRUSA, “HSM1 - Hybrid Synchronous Motor,” **613**, pp. 0–1.
- [19] DriverSide, “2012 Ferrari 458 Italia Technical Specifications” [Online]. Available: [http://www.driverside.com/specs/ferrari-458\\_italia-2012-30960-54122-0](http://www.driverside.com/specs/ferrari-458_italia-2012-30960-54122-0). [Accessed: 22-Nov-2015].
- [20] Craftsman, “Craftsman C3 19.2-Volt Lithium-Ion 3/8-in. Drill/Driver Kit - Tools - Cordless Handheld Power Tools - Drills” [Online]. Available: <http://www.craftsman.com/craftsman-c3-19.2-volt-lithium-ion-3-8-in/p-00945200000P>. [Accessed: 13-Dec-2015].
- [21] Panasonic, 2012, “Li-Ion NCR18650A Datasheet,” p. 18650.
- [22] Barlow, T., Latham, S., McCrae, I., and Boulter, P., 2009, “A reference book of driving cycles for use in the measurement of road vehicle emissions,” p. 280.
- [23] Tesla Motors, “The Magic of Tesla Roadster Regenerative Braking | Tesla Motors” [Online]. Available: <https://www.teslamotors.com/blog/magic-tesla-roadster-regenerative-braking>. [Accessed: 13-Dec-2015].

### Appendix A: Power for Maximum Initial Acceleration

From the assumed torque-speed curve, it was determined that maximum acceleration could be obtained if the EM is sized and geared to provide sufficient torque to meet the friction limit of the tires from 0 to 100 km/hr. As shown in FIGURE 14, the power required for this function is 327 kW.

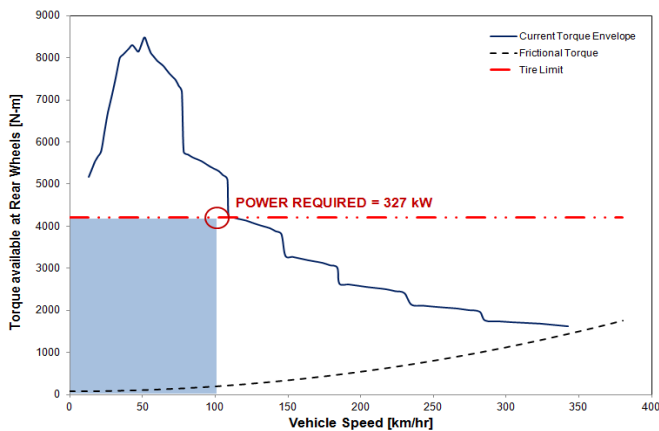

FIGURE 14: Power required for 0 to 100 km/hr acceleration

Then assuming a power density of 3 kW/kg [18], the mass of the EM is estimated to be 109 kg. The weight of batteries required for this application, assuming an energy density of 225 Wh/kg, was 54 kg [21].

### Appendix B: Weight and Inertia Summary

TABLE 6 provides a comparison of the estimated weight and inertia for the proposed architecture against a dual clutch transmission (DCT) which is often used for performance applications.

TABLE 6: Weight and Inertia comparison

	DCT		Proposed Architecture	
	Weight [kg]	Inertia [kg-m <sup>2</sup> ]	Weight [kg]	Inertia [kg-m <sup>2</sup> ]
Shafts	9	0.001	11.3	0.001
Synchronizers	1.3	0.001	2	0.001
Gears	27.2	0.031	22.9	0.026
Clutch	33.2	0.124	0	0
ICE	0	0.105	0	0.105
Motor	0	0	51	0.065
Batteries	0	0	76	0
Transmission oil	3.9	0	3.3	0
Clutch oil	8	0	0	0
Enclosure	62.3	0	66.6	0
<b>Total</b>	<b>144.9</b>	<b>0.262</b>	<b>233.1</b>	<b>0.199</b>

### Appendix C: Shifting Time Calculations

*Assumptions for the calculations*

The electric motor used for this calculations was the HSM1-10.18.13 Brusa 400V motor. [18] Also, the data used for the ICE max torque speed curve and tire diameter was provided by our project sponsors. The gear ratios assumed for this analysis are provided in TABLE 4.

The time to speed up or slow down one shaft with the gearing through the EM was computed using the following equation:

$$t = \frac{I_{eff} * \omega}{\tau_{out}}$$

With  $\omega$  the goal speed of the gearing,  $I_{eff}$ , the inertial load on the EM and  $\tau_{out}$  the average torque delivered by the EM during this process.

A similar method was adopted to compute the time the ICE takes to speed up or down. Our project sponsor also gave us data that enabled us to make the assumption that the time to change the throttle and the torque of the engine is about the time for the engine to perform one revolution, or  $t = 1/\omega$ , where  $\omega$  is the engine speed.

The time to shift and engage a synchro when the speed of the two rotating components are matched was set to 0.0081sec. [25]

*Shifting time calculations*

Following these assumptions, the time to realize each sequence from the shifting procedures was computed and then added up to retrieve the total shifting time.

To estimate the downshifting time from fourth gear to fifth gear we proceeded the following way:

1. Four synchronizer are shifted during the sequence so it takes  $t_{sync} = 4 * 0.0081 = 0.032 \text{ sec}$
2. The EM has to speed up the 4006 RPM in order to match the ICE speed. The EM provides 305Nm torque and has an inertia of 0.065 kg.m<sup>2</sup> so it takes

$$t_{EM} = \frac{0.065 * (4006 * (\frac{2\pi}{60}))}{305} = 0.142 \text{ sec}$$

3. The EM then has to speed up the ICE to match the speed of the car in gear 4. The EM speed increases from 4006 RPM to 4766RPM. It provides a 305 Nm torque and has to bear its own inertial load along with the inertial load of the shaft, and the ICE which adds up to 0,224 kg.m<sup>2</sup> so it takes

$$t_{ICE} = \frac{0.224 * (760 * (\frac{2\pi}{60}))}{305} = 0.038 \text{ sec}$$

By adding all these times, the estimate of the downshifting time procedure from gear 4 to gear 5 is 0.204 s. A similar approach was used to estimate the other shifting times.