

THE DESIGN OF A HAND-POWERED LEVER-DRIVEN TRICYCLE FOR THE HANDICAPPED

by

Brian T. Sawyer

Submitted to the Department of Mechanical Engineering
in Partial Fulfillment of the Requirements for the Degree of

Bachelor of Science

at the

Massachusetts Institute of Technology

May 1993

© Brian T. Sawyer 1993
All Rights Reserved

The author hereby grants to MIT permission to reproduce and to
distribute publicly copies of this thesis document in whole or in part.

Signature of Author _____
Department of Mechanical Engineering
May 7, 1993

Certified by _____
Adjunct Professor Igor Paul
Thesis Supervisor

Accepted by _____
Professor Peter Griffith
Department Committee Chairman

ARCHIVES

MASSACHUSETTS INSTITUTE
OF TECHNOLOGY

JUN 17 1993

LIBRARIES

Abstract

THE DESIGN OF A HAND-POWERED LEVER-DRIVEN TRICYCLE FOR THE HANDICAPPED

by

Brian T. Sawyer

**Submitted to the Department of Mechanical Engineering
on May, 7 1993 in partial fulfillment of the
requirements for the Degree of Bachelor of Science in
Mechanical Engineering**

This thesis details the conceptual design of a lever-driven tricycle intended for use primarily by the handicapped without the ability to use their legs. The primary motivation behind the design is the desire to fill a gap in available cycling technology for the handicapped. A pair of drive gears are chained to the sprockets of the rear wheels and are driven by levers on either side of the rider. The rider sits in a semi-recumbent position while pulling through the power stroke. Force and power estimates were made at 100 lbs and 500 ft-lbs, respectively, through a power input length of 2.5 feet. Calculations were made pertaining to maximum velocities, turning radii, and the stability of the tricycle. Stability and velocity calculations were also performed on a 15° grade in addition to a flat surface. The tricycle is quite capable of travelling at a velocity of 20 ft/sec (14 mph) on flat terrain and 6 ft/sec (4 mph) up a 15° slope. The tricycle also meets standard stability requirements as they exist for a wheelchair, being stable through a stopped-tire turn on a 15° slope at a velocity of 3 mph. Additionally, when negotiating a turn of radius 10 feet, the tricycle is capable of travelling 14.4 ft/sec; in a turn of radius 20 feet, the tricycle can travel up to 20.4 ft/sec without tipping.

Thesis Supervisor: Professor Igor Paul

Title: Adjunct Professor of Mechanical Engineering

Table of Contents

Abstract

Table of Contents

List of Figures

Dedication

Acknowledgements

1. Introduction

2. Conceptual Overview

2.1 Design Description

2.2 Design Assumptions

3. Design Components

3.1 The Frame

3.1.1 Frame Dimensions

3.1.2 Rider Visibility

3.2 Propulsion

3.2.1 Drive Levers

3.2.2 Power Input

3.2.3 Drive Train

3.3 Steering

3.3.1 Methods of Steering

3.3.2 Stability

4. Conclusions and Recommendations

References

List of Figures

- Figure 1. Tricycle Concept (side)**
- Figure 2. Tricycle Concept (top)**
- Figure 3. Tricycle Concept (front)**
- Figure 4. Drive Levers**
- Figure 5. Drive Train**
- Figure 6. Stability Testing (sloped, flat)**

Dedication

This thesis is wholly dedicated to my family, whose unwavering support of my every decision has made possible my survival at MIT. To them, I will be forever grateful. Thanks a million.

Acknowledgements

I would like to thank my mom, dad, Dave, Lori, Charlie, and Lindsey for their love and support through my four years at MIT. Without them, I would never have survived this place. Loving thanks to Joy for sticking with me through the four most difficult years of my life. Thanks to Igor Paul for providing his design knowledge and expertise. Thanks also to all my good friends at school, who have collectively made this the most hilarious and interesting place that I will ever encounter. Thanks to all those before me whose research has partially cleared the road to my own tricycle design. Thanks to all the wonderful people at St. John of God Community Services for giving me the experience of a lifetime over a single summer and for showing me the true abilities of the mentally and physically handicapped. And finally, special thanks to Mike Doane for instilling in me the spark to design creatively and for the good of mankind.

1. Introduction

The science of bicycle and tricycle design has been elevated to a degree such that significant improvement of existing designs becomes a daunting task. Aerodynamic and light-weight frame design has become the principle motivator driving new cycling technology for use in racing and leisure. However, these designs typically entail the use of the legs for propulsion and the hands and arms for steering, leaving a handicapped individual who cannot rely on his legs without a viable method to enjoy a ride on a bicycle. Very few designs exist which attempt to address this problem, and most of them simply provide the pedal system of an ordinary bike placed so that the individual may use his hands to crank the pedals and steer. This is an inefficient and exhausting way to power and steer a bike, so I set out to design a cycling mechanism which makes more efficient use of the natural power of the human upper body.

When using the upper body, it seems that a pulling motion similar to rowing, which makes use of both the lower back muscles and biceps of an individual, would be the most efficient and least exhausting way to provide propulsion. Indeed, several wheelchairs have been crafted which take advantage of this fact (Giannini, p. 91-2). They use clutched levers and chain drives to provide power, eliminating the need to push using hand rails which are uncomfortable, inconvenient, and inefficient. More important and limiting, though, is the fact that hand rails supply a finite torque to the wheels through whatever power stroke the user is capable of providing, without a mechanism to provide any mechanical advantage. Levers provide a moment arm which the user can apply a force to and increase the amount of torque delivered to whatever drive train exists in the design.

The work of Joseph Jones in *A Frictional Ratchet for Wheelchair Propulsion* pursues a slightly different version of the same idea, using a frictional ratchet to supply torque by directly contacting the wheels of the wheelchair from a pair of T-shaped handles pivoted about the wheel axis. Alessandro Bilotta improved this design in *An Improved Frictional Ratchet for Wheelchair Propulsion*, but I chose to approach the problem of supplying power through levers in a different manner.

Although this thesis does not detail the design of a new wheelchair system, I have used some criteria for wheelchair design where government regulation and standards potentially may apply, particularly in the areas of size and stability. The tricycle I designed has been conceptualized from beginning to end as a recreational vehicle, not intended to be the prime mode of transportation for an individual. In addition, I designed this machine with the intent that both handicapped and non-handicapped individuals would be capable of enjoying a pleasant ride. Finally, it should be noted that this thesis outlines the principles and mechanisms with which such a tricycle may be designed and built, but it makes no attempt to dictate precisely the components comprising these mechanisms. The thesis is conceptual, and does not represent a final vehicle design.

2. Conceptual Overview

2.1 Design Description

Refer to figures 1-3 for drawings of the design concept. The tricycle design which was developed uses a pair of levers as moment arms which supply torque and power to a geared chain drive on either side of the frame. The levers are racheted to the driving gears so that power can be supplied through a pulling stroke toward the body and returned to a ready position away from the body. Caliper bike brakes are located on the handles, supplying braking capabilities and a partial means of steering the tricycle. The rear wheels of the trike are independent of one another so that extra power supplied to one lever will tend to steer the trike in the opposite direction. A combination of touch-braking and differential lever power produce a steering mechanism that the rider must learn to control as he gains riding experience. The rider sits in a modified semi-recumbent position with knees bent and legs raised approximately to chest level. To supply optimum power, he must lean forward slightly as would a rower, pulling the levers toward his body while moving to rest his back on the seat. The front wheel is a caster which follows the natural inclination of the trike to turn in whatever direction the rider designates.

2.2 Design Assumptions

In developing the concepts for this tricycle, I worked with power and force estimates taken from reference materials. Upper-bound weight assumptions were also made for the machine and rider so that the design would be robust enough to handle a wide range of rider weights. J.Y. Harrison (Whitt & Wilson, p. 43) determined that a maximum power output for a "healthy man" while rowing is approximately 1 horse

power or 550 ft-lb, and that the power supplied after 5 minutes of rowing is approximately 0.5 hp, or 275 ft-lb. Since velocity calculations for the tricycle were taken assuming a relatively steady-state speed, lower bound power assumptions were made in order to determine the realistic capability of a rider to power the machine after sustained riding. Estimates were made based on a tricycle weight of 60 pounds and a rider weight of 180 pounds. These figures are important primarily for stability and velocity calculations.

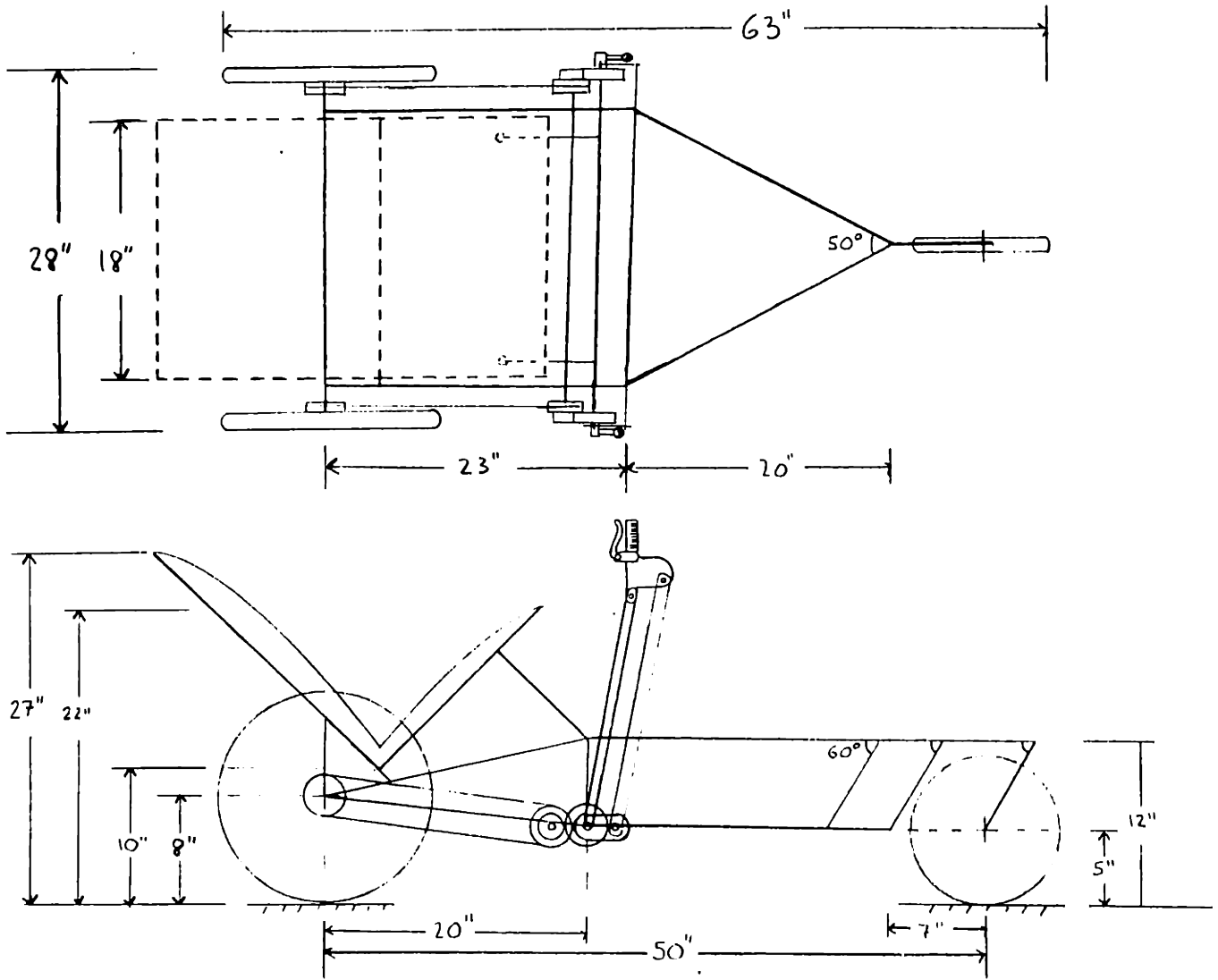

Figures 1 and 2: Side and Top Views of Tricycle

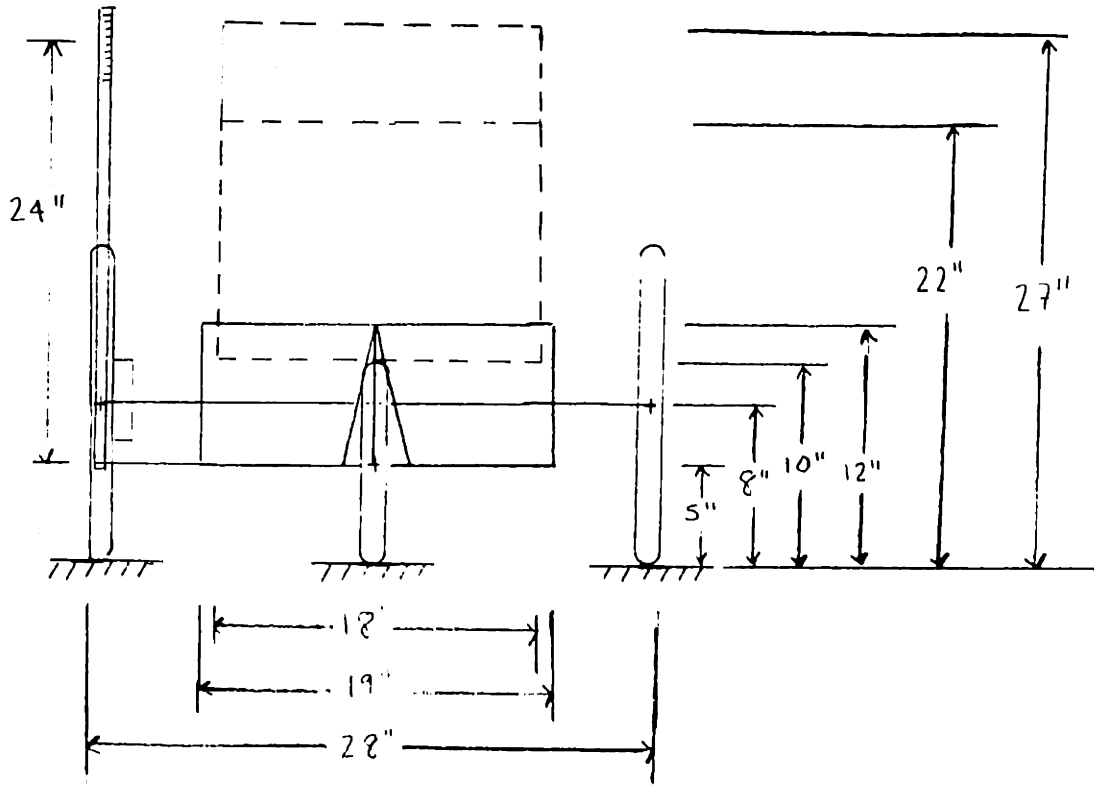

Figure 3: Front View of Tricycle

3. Design Components

3.1 The Frame

3.1.1 Frame Dimensions

The frame of the tricycle supports the seat with a bar over each side of the axle. It then forks upward and downward as it moves away from the rear wheels. The drive levers are mounted at the sides of the frame (see figure 4) and support the gear drives through the power stroke. From there, the frame extends to the front of the machine, tapering gradually inward until joining the castored front wheel.

When selecting the dimensions of the frame and the wheels, there were specific width limitations as set forth by handicapped patient facilities regulations. The tricycle was not to be wider than 29 inches because doorways are only 30 inches wide. Although I have stated previously that this tricycle is not meant to serve as a primary means of transportation (indeed, the length of the trike makes it an impractical and unwieldy means of conveyance indoors), I felt that adherence to such regulations was desirable, considering that an individual may want to store the trike indoors and would be fairly irate if the machine did not fit through his front door. Several different tire diameters and body configurations were analyzed, with the overall length of the trike and the position of the center of gravity being primary design criteria. The optimum weight distribution for a wheelchair is 60 percent to the rear wheels and 40 percent to the front wheels (Giannini, p. 38) and, although I did not feel it necessary to adhere steadfastly to those figures, I did try to arrive at a weight distribution which was nearly the same to optimize performance and to produce a similar response in a transition from wheelchair to tricycle. A preliminary sketch of a frame with 27 inch rear tires and a 16 inch front tire produced

an oversized tricycle over 7 feet (85 inches) long. Reducing the tire diameters to 16 inches and 10 inches respectively, I arrived at a design which is 5.3 feet (63 inches) long. This could further be reduced by placing the front tire axle between the rider's feet, but that decision is a matter of preference and I chose to place the wheel in front of the rider's feet, allowing the tricycle a gradual taper to the castered front wheel fork.

Center of gravity calculations were made for the various proposed tricycle sizes, but most were not close to a reasonable weight distribution between the two axles. I sought a distribution which avoided the danger of a rider shifting his weight too far to the rear of the seat, thereby shifting the CG dangerously close to the rear axle, potentially causing instability and rearward tipping about the rear axle. The center of gravity of the machine I selected, along with its rider, was estimated to be approximately 10 inches from the rear axle and 40 inches from the front axle. Using the rider and tricycle weights indicated above produces a weight distribution of approximately 80 percent to the rear wheels and 20 percent to the front wheels.

3.1.2 Visibility

The riding position of the body was found by first taking measurements of appropriate body dimensions. Tables compiled by HumanScale were used as references. The distance from the buttocks to the back of the knee and the distance from the back of the knee to the bottom of the foot were each approximately 20 inches. The partially bent position which the legs take while the tricycle is ridden forms an angle of approximately 120° , with the horizontal distance between the buttocks and the feet being 36 inches.

When considering the riding position of the user, it was necessary to supply the rider with a reasonable degree of visibility over his raised legs. From the normal riding position, the user can see the front wheel and therefore the terrain and any obstacles which are approaching. Side visibility is unobstructed and the individual will generally view his ride with a line of sight angled just above the knees.

3.2 Propulsion

3.2.1 Drive Levers

Figure 4 details the levers by which the rider powers the drive train and wheels. The design features a simple four-bar linkage which keeps the handles vertical to the ground through the complete power and return strokes. This is desirable because the rider's hands may otherwise slip off the handles frequently as the stroke draws nearer to his body. The rider may therefore apply a force to the handles which is nearly horizontal as he pulls through the stroke, rather than needing to focus on shifting the direction of the applied force to coincide with the awkward and shifting orientation of the handles.

At the end of a power stroke, the handles are approximately located near the rider's hips or perhaps slightly further back. The length of the power stroke is obviously dictated by the rider, and will no doubt vary as the velocity of the bike or the angle of slope of the terrain shift. At this time, it is essential that the rider is able to consistently move the levers through the ratcheted return stroke to prepare for another power stroke. If, for some reason, the rider loses his grip on one lever, that lever may potentially fall out of reach behind the rider. This unfortunate occurrence would leave the rider essentially helpless and at the whims of physics and immovable obstacles. To combat this potential problem, a pliable spring is mounted between the two linkages. Spring equilibrium occurs where the lever is perpendicular with the ground. When the handles are close to the body, the spring is in tension and, if released, will move back to equilibrium where the rider can easily reach the handle. The spring stiffness must be low enough to prevent overstretching during regular use, but strong enough to return the lever to equilibrium. Due to the geometry of the linkage, the spring extension will be no more than a few

inches, regardless of its mounted position on the linkage. A spring with a spring constant $k = 10\text{-}20$ lb/ft would likely be sufficient to return the levers to a ready position.

There is no accompanying spring for the beginning of the stroke, however, because no spring would be able to return the lever to an upright position through the power stroke. Instead, there is a stop which limits the distance the lever can be pushed forward. There is an accompanying stop at the end of the stroke as an additional safety measure.

The dimensions of the lever mechanism are indicated in figure 4. The pulling force is applied approximately through the center of the handle, at a distance of 2 feet from the center of the driving sprocket. If a lever was to complete a single revolution about its axis, it would sweep out an arc of 12.6 feet. Of this, however, only a quarter is actually feasible in the design. This maximum stroke would seldom be applied, though, so power calculations have been made using a more modest estimate of 2.5 feet. This is still enough stroke to power the trike.

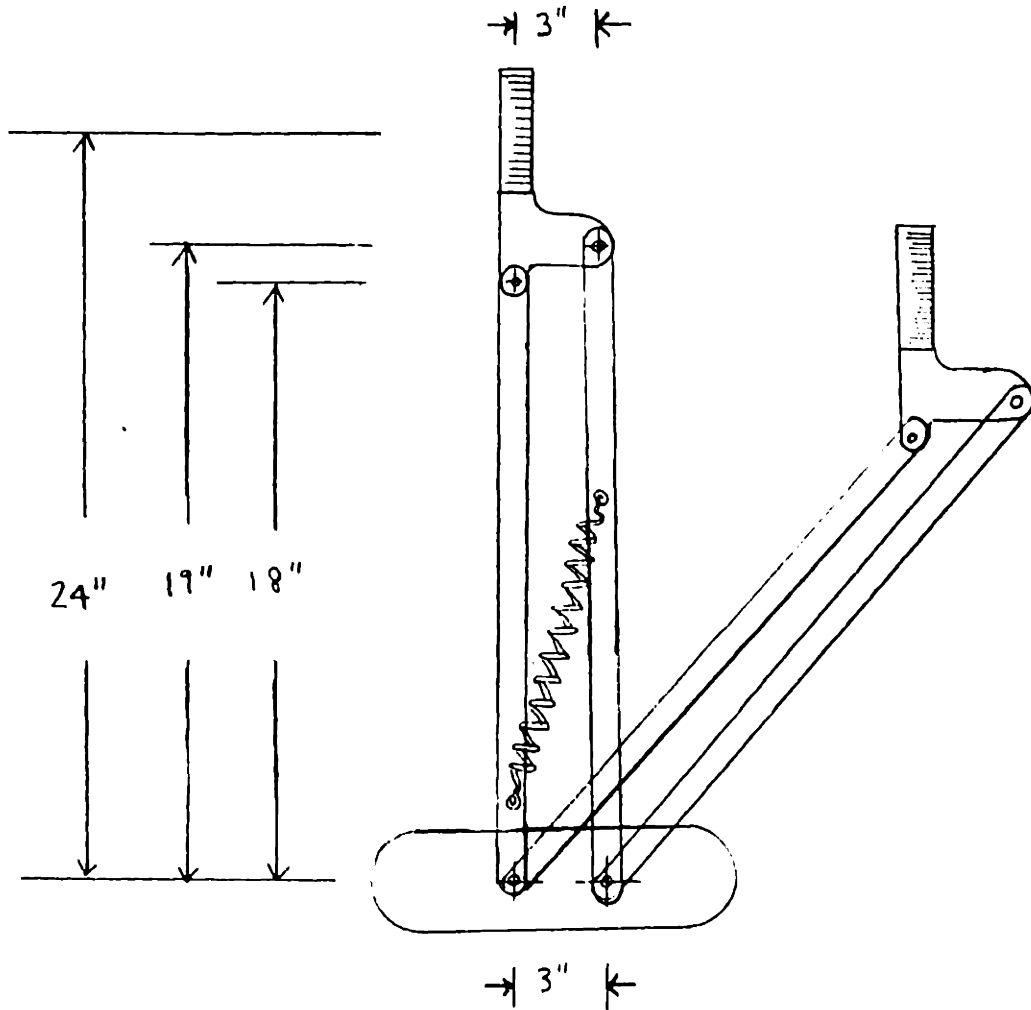

Figure 4: Detail of Drive Levers

3.2.2 Power Input

Assume that a complete power stroke can be achieved every second. In the Human Factors Design Handbook, W.E. Woodson indicates approximate force applications for various forms of human exertion. Including the forces for back muscles and biceps, the force was calculated to be approximately 100 pounds for each arm. Applying the relation

$$P = F d / t \quad (1)$$

with a force of 100 pounds and a stroke of 2.5 feet and a stroke duration of 1 second, the power output is found to be 500 ft-lb/sec.

On level terrain, the rider must overcome only the frictional force between the tires and the ground. Assuming a friction coefficient of $\mu = 0.1$, a weight of 240 pounds, and using the relation

$$F_f = \mu Mg \quad (2),$$

the frictional force which must be overcome is $F_f \approx 25$ pounds. Using the relation

$$P = F v \quad (3)$$

and inputting the applied power and frictional force yield a tricycle velocity of 20 ft/sec, or approximately 14 mph.

In addition to determining the performance of the tricycle over flat terrain, it is necessary to determine how well it will drive up a slope. A slope of 15° was used as a test slope and the forces acting on the tricycle were analyzed. When travelling uphill, the opposing force consists of the frictional force of the tires plus an additional horizontal

component for the weight of the tricycle. The applicable equation is

$$F_f = Mg (\mu \cos\Theta + \sin \Theta) \quad (4).$$

Using an angle of slope of $\Theta = 15^\circ$ and $Mg = 240$ lbs, the force resisting forward motion of the tricycle is approximately 85 lbs. With a power input of 500 ft-lbs/sec, this would yield a velocity (using equation 3) of approximately 6 ft/sec (4 mph). This velocity is significantly smaller than that for a flat surface, due to the contribution of the horizontal weight component. However, this is certainly sufficient to propel the trike.

The precise manner of propulsion will vary according to changes of terrain slope and roughness. For flat or downward sloping terrain, a rider could easily push through a power stroke then glide for a distance, applying more power only when feeling the need for it. However, when climbing a slope, it seems that a succession of short, quick power strokes would be better suited, as the tricycle would tend to decelerate significantly through a long return stroke at approximately 0.5 ft/sec^2 on a 15° slope.

3.2.3 Drive Train

The drive train consists of the lever, a driving gear, and a compound gear linked to the rear wheel sprocket by a standard bicycle chain. The drive levers are racheted to the driving gear, and the rear wheels are racheted to the rear sprockets. Figure 6 shows a detail of the drive train. Timing belts were considered as possible links, but the potential construction of the tricycle will be greatly simplified if it is designed using as many standard bicycle parts as possible.

The desired top speed of this tricycle is in the range of 20-30 ft/sec, or approximately 15-20 mph. In order to achieve the top speed with the estimated one

stroke/sec of length 2.5 feet, the complete drive train must have either an 8:1 or 12:1 gear ratio. The 24 inch lever and the 8 inch radius of the rear wheel form an external 3:1 ratio which is constant, independent of the configuration of gears used in the body of the transmission. Therefore, the driving sprocket, the compound gear, and the rear wheel sprocket may form any desirable configuration of radii and gear teeth which will achieve an internal ratio of 4:1, 3:1, or whatever is desired, depending on the strength, needs, and desires of the individual rider. In the detail drawing of the drive train, these internal gears are represented in a black box, indicating that any number of different gear ratios may be achieved. One simple configuration involves two 2:1 ratios, one between gears B and C and another between gears D and E. One must remember, however, that gearing down also carries with it an accompanying decrease in torque which is supplied to the tires.

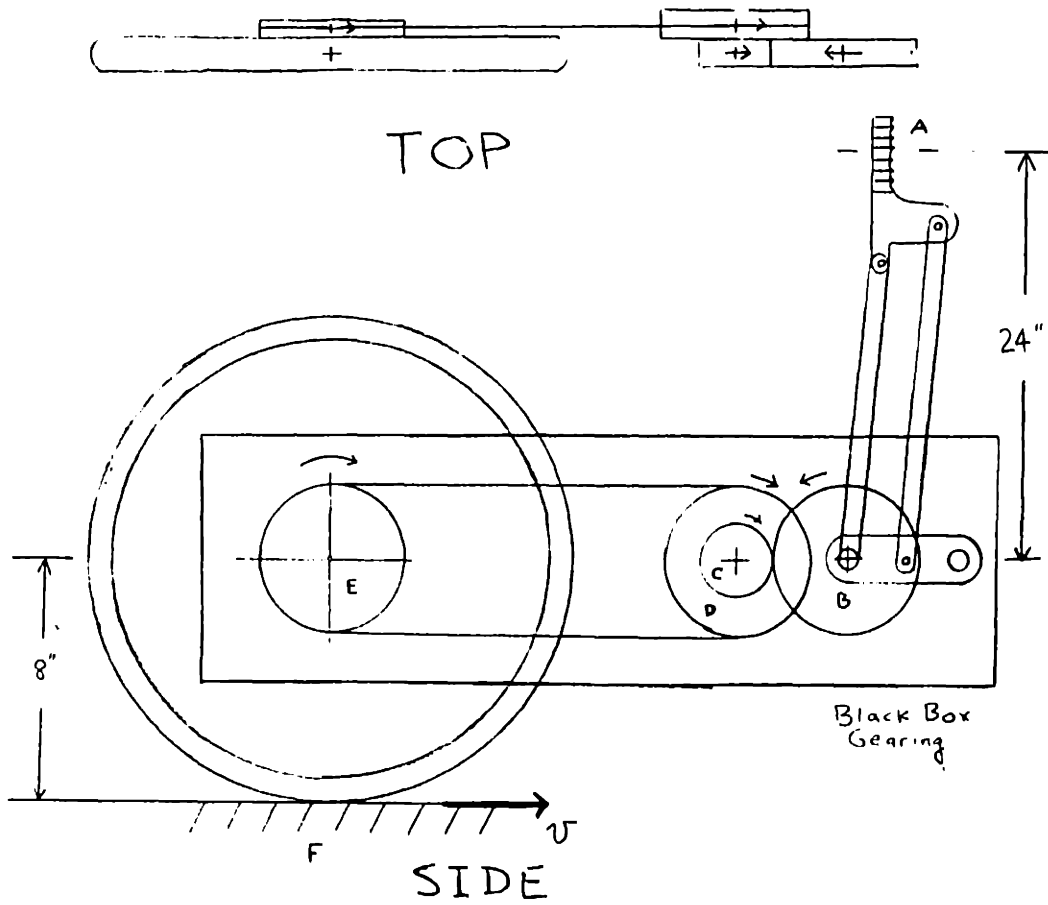

Figure 5: Drive Train of Tricycle

3.3 Steering

3.3.1 Methods of Steering

The rider of the tricycle can use a combination of differential lever forces and brakes to steer the trike to one side or the other. The caster on the front wheel simply follows the direction in which the rider propels the trike. For example, pulling exclusively on the right lever while in motion will tend to steer the tricycle to the left. Tapping the left brake a number of times will additionally slow the rotation of the left wheel, amplifying the effect of the differential power applied with the levers.

3.3.2 Stability

A wheelchair must be capable of travelling 3 mph (4.4 ft/sec) on a 15° incline in any direction and it must additionally resist flipping when the rotation of one wheel is stopped suddenly. In other words, the weight must be greater than the centrifugal force when moments are calculated about the stopped tire. A tricycle should probably have a comparable stability threshold. A wheelchair tips over the contact points of its tires, but a tricycle tips over a tipping axis which extends from the rear tire axle to the front tire axle.

Figure 6 shows free body diagrams of the tricycle for a stability test. The centrifugal acceleration acts perpendicular to the tipping axis, so the moments must be calculated about this axis. When travelling on the tricycle at 4.4 ft/sec and suddenly braking one tire completely, the radius of the ensuing turn becomes 1.3 feet, the horizontal distance of the CG to the contact point of the stopped tire. The centrifugal acceleration on the rider and the tricycle is

$$a_c = v^2 / R \quad (5)$$

where v is the velocity of the trike and R is the radius of the turn. Using a velocity of 4.4 ft/sec and a radius of 1.3 feet, the centrifugal acceleration is found to be 14.9 ft/sec^2 , or approximately 0.46 g's. For a combined rider and tricycle weight of 240 pounds, the centrifugal force is found to be 110 lbf.

From figure 6, a moment equation can be derived for the stability of the tricycle on a flat surface which depends on the tricycle parameters. Calculating moments about the tipping axis shows that the tricycle will be stable if the following inequality is satisfied:

$$W a \sin \Theta > W h (v^2 / g R) \quad (6),$$

where W is the weight of the tricycle and d , h , and Θ are tricycle dimensions.

When testing stability on a slope, the centrifugal force remains the same. However, the weight vector falls closer to the tipping axis, and will therefore not stabilize the tricycle as effectively as it would on level terrain. This distance is $d_{\text{slope}} = (d \sin \Theta - h \sin \Phi)$, where Φ is the angle of slope. This yields a new equation for calculating slope stability:

$$W (a \sin \Theta - h \sin \Phi) > W h (v^2 / g R) \quad (7).$$

When the weight moment is greater than the moment of centrifugal force, the tricycle is stable. Using this equation to calculate the tricycle stability on the slope, one finds that the tipping moment remains 110 lbf-ft, but the restoring force of the tricycle weight is reduced to 121 lbf-ft. However, the tricycle will remain upright and stable on a slope of

15° at a velocity of 4.4 ft/sec.

The tricycle must also be stable through turns of reasonable radii and velocities.

Assuming a level riding surface, equation (6) can be manipulated so that

$$v < [(a g R / h) \sin \Theta]^{1/2} \quad (8).$$

This is a useful relationship for calculating maximum velocity through a turn of a given radius on flat terrain. Using the parameters indicated in figure 7 and a radius of 5 feet (approximately the radius of a 90° turn around the corner of a city block, for instance), the tricycle is capable of travelling at a velocity of 10.2 ft/sec. The tricycle can navigate a turning radius of 10 ft/sec at a velocity of 14.4 ft/sec. With a turning radius of 20 ft, the tricycle can travel up to 20.4 ft/sec. Obviously, equation (6) can also be manipulated to produce allowable minimum radii at given velocities.

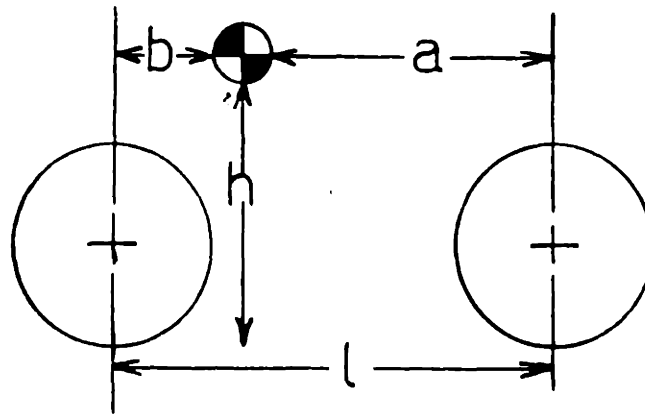
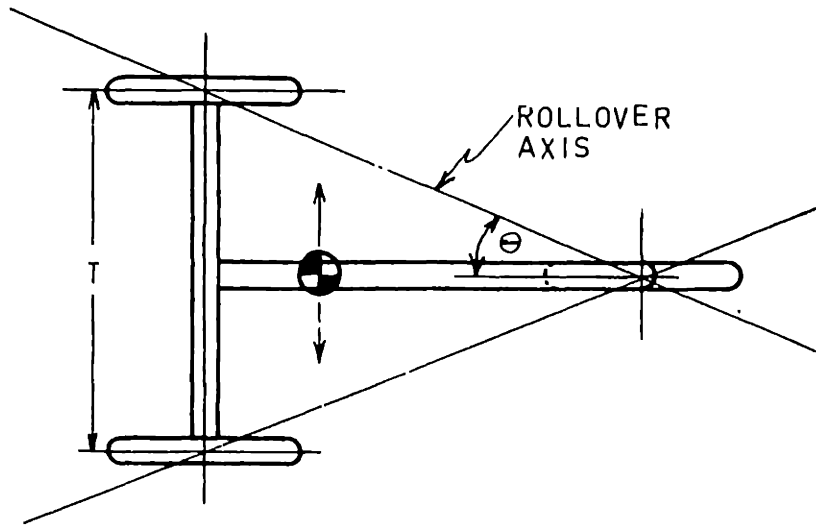

$a = 3.3$ ft
 $h = 1.3$ ft
 $Q = 15.10$
 $T = 2.25$ ft
 $l = 0.8$ ft
 $b = 0.83$ ft

Figure 6: Stability Testing of Tricycle

4. Conclusions and Recommendations

The performance of the tricycle can obviously not be measured exactly without the existence of a prototype based on the design. However, through calculation of power inputs and achievable velocities, it has been shown that the tricycle is capable of travelling at speeds of 10-15 mph reliably without severely fatiguing the rider. Additionally, the trike is stable under reasonable turning conditions and exhibits no apparent tendency to tip within the design parameters.

However, there are shortcomings in the design. The use of two independent chain drives greatly restricts the range of allowable speeds. A central drive could be used in future development which is ratched on each side to the two levers. The use of this central drive would allow the installation of a derailleur and multiple speed gearing. This would increase the maximum velocity of the tricycle in a steady-state riding condition, decrease the effort needed to begin motion, and decrease rider fatigue in the higher gears.

The reliance on rear-wheel steering is risky but plausible, although it would be much more desirable to link the levers to the front wheel by using a linkage near the base of the frame. A rack and pinion could potentially be mounted and secured between the two levers. Motion of the levers to the right or left would transfer motion to the rack and pinion, and then to the front wheel through whatever linkage is desired. This would allow the rider to push to the left or right, turning the machine while continuing to apply power.

Portability of this tricycle is another potential problem, although my design assumptions have been that this will be a device using strictly outdoors, and hence located always outdoors. However, the time may come when a rider would like to

transport the machine to another rider location. I believe modifications could be made in the design which would allow the frame to slide in upon itself, and perhaps the wheels to fold up under the frame. These are issues that future improvements of the design concepts should implement.

References

Bilotta, Alessandro, An Improved Frictional Ratchet for Wheelchair Propulsion, Department of Mechanical Engineering, MIT, June 1990.

Blanco, Ernesto E., Elements of Kinematics, Course 2.70, Department of Mechanical Engineering, MIT.

Giannini, Margaret J., M.D., Choosing a Wheelchair System, Journal of Rehabilitation Research and Development, Clinical Supplement # 2, Washington, D.C., March 1990.

Laiterman, Lee Howard, Theory and Application of Rear-Wheel Steering in the Design of Man-Powered Land Vehicles, Department of Mechanical Engineering, MIT, May, 1977.

Sharp, Archibald, Bicycles and Tricycles, MIT Press, Cambridge, Massachusetts, 1977.

Whitt, Frank Rowland & Wilson, David Gordon, Bicycling Science, MIT Press, Cambridge, Massachusetts, 1982.