

Real Estate Securitization in Korea: Application of PF ABS and MBS

by

Jee hee Baek

Bachelor of Architecture, 2013

Hongik University

**Submitted to the Program in Real Estate Development in Conjunction with the Center for Real Estate in
Partial Fulfillment of the Requirements for the Degree of Master of Science in Real Estate Development**

at the

Massachusetts Institute of Technology

September, 2020

©2020 Jee hee Baek

All rights reserved

The author hereby grants to MIT permission to reproduce and to distribute publicly paper and electronic copies of this thesis document in whole or in part in any medium now known or hereafter created.

Signature of Author _____

**Center for Real Estate
June 30**

Certified by _____

**Walter Torous
Senior Lecturer, Department of Urban Studies and Planning
Thesis Supervisor**

Accepted by _____

**Professor Dennis Frenchman
Class of 1922 Professor of Urban Design and Planning
Department of Urban Studies and Planning
Director, MIT Center for Real Estate**

Real Estate Securitization in Korea: Application of PF ABS and MBS

by

Jee hee Baek

Submitted to the Program in Real Estate Development in Conjunction with the Center for Real Estate on June 30, 2020 in Partial Fulfillment of the Requirements for the Degree of Master of Science in Real Estate Development

ABSTRACT

This thesis studies the application of securitization such as Project Finance Asset-Backed Securities (PF ABS) and Mortgage Backed Securities (MBS) as a method of real estate finance in Korea.

Real estate in Korea has developed substantially with a remarkable economic growth in last 20 years. As real estate became one of the most popular investment methods, real estate finance also developed into a more diversified and complex structure. Real estate securitization provides an alternative to the traditional way of financing by liquidating the real estate related assets and makes access easier for all participants in the process.

In Korea, real estate securitization was first adopted in 1999, with the initiation of the Asset Securitization Act. Though the concept of Asset-Backed Securities (ABS) started late compared to the global securitization industry, the Korean ABS market has grown so substantially that the total issuance amount reached \$43 billion in 2019, having expanded by almost eight-fold from the beginning of the market in 1999. With a considerable progress in the market, some of securitization products have developed with distinctive features.

Of many products, this thesis mainly studies two types of real estate securitization products, Project Finance Asset-backed Securities (PF ABS) and Mortgage-backed Securities (MBS). By going through the market trends and social context of both products, it will cover what can be suggested for further improvement of the real estate finance market in Korea.

Thesis Supervisor: Walter Torous

Title: Senior Lecturer, Department of Urban Studies and Planning

Acknowledgement

I would like to thank my thesis advisor, Walter Torous, for guiding the thesis writing and sharing all his insights regarding real estate finance and securitization. His class “Securitization of Mortgages” motivated me to study further about other markets and products.

I am also grateful to Tricia Nesti, for her kind support and help, and to CRE, for hard effort making all learning experience possible even during covid-19 crisis.

Finally, special thanks to my parents and sister, for their unconditional support and encouragement.

TABLE OF CONTENTS

Abstract

Acknowledgement

Introduction

1.0 Chapter 1: Real estate finance history in Korea

- 1.1 Before 1998, Asian Financial Crisis
- 1.2 Early 2000, Opening markets after IMF
- 1.3 After 2008, Global Financial Crisis (GFC) and market downturn
- 1.4 Recent Real Estate Market Trend

2.0 Chapter 2: Real Estate Securitization

- 2.1 Definition and purpose
- 2.2 Securitization Structures
- 2.3 Real Estate Securitization product type
- 2.4 Securitization Market History and trend

3.0 Chapter 3: Project Finance Asset-Backed Securities (PF ABS/Project Bond)

- 3.1 Project Finance Loans
 - 3.1.1 Overview of Project Finance Loans
 - 3.1.2 Features of Project Finance Loans in Korea
 - 3.1.3 Crisis of Project Finance Loans in Korea
- 3.2 Securitization of Project Finance Loans
 - 3.2.1 Overview of Project Finance Asset-Backed Securities (PF ABS/Project Bonds) in Korea
 - 3.2.2 Structures of Project Finance Asset-Backed Securities in Korea
- 3.3 Market Trend
 - 3.3.1 PF ABS Market in Korea
 - 3.3.2 Global PF ABS Market
- 3.4 Further Discussion for Improvement

4.0 Chapter 4: Mortgage-Backed Securities (MBS)

- 4.1 Concept of Mortgage-Backed Securities (MBS)
 - 4.1.1 Overview of Residential Mortgage-Backed Securities (RMBS) and Commercial Mortgage-Backed Securities (CMBS)
 - 4.1.2 Features of MBS market in Korea
- 4.2 RMBS in Korea
 - 4.2.1 Residential Mortgage Loan market
 - 4.2.2 Residential Mortgage Securitization Agency
 - 4.2.3 Structure of RMBS
- 4.3 Market Trend

Conclusion

Bibliography

Introduction

Real estate in Korea has developed substantially with a remarkable economic growth in the last 20 years. As real estate became one of the most popular investment methods, real estate finance also developed into a more diversified and complex structure. This led more participants into the market so that the market evolved to satisfy investors with different risk profiles and demands. Real estate securitization provides an alternative to the traditional way of financing by liquidating real estate related assets and makes access easier for all participants in the process.

In Korea, real estate securitization was first adopted in 1999, with the initiation of Asset Securitization Act and the first government Mortgage-backed Securities (MBS) were also issued in 2000. After the financial crisis, it was suggested as a counteractive economic stimulus policy pursued by the government to promote the real estate market to develop. Though the concept of Asset-Backed Securities (ABS) started late compared to the global securitization industry, the Korean ABS market has grown so substantially that the total issuance amount reached \$43 billion in 2019, having expanded by almost eight-fold from the beginning of the market in 1999. With considerable progress in the market, some securitization products have developed with distinctive features.

Of many products, this thesis mainly studies two types of real estate securitization products, Project Finance Asset-backed Securities (PF ABS) and Mortgage-backed Securities (MBS).

PF ABS, which is an equivalent concept of Project Bonds in international terminology, combined with the unique development project structure in Korea and provided a way to liquidate PF loans for projects. Even though it may not be the most commonly preferred financing method in the US, PF loans and PF ABS in Korea flourished in the mid-2000s and the trend has moved to Project Finance Asset-backed Commercial Paper (PF ABCP) more

recently. But with its popularity, as PF securitization posed a considerable risk in history, this thesis examines the social context to figure out what happened in the PF market and what might be suggested for further improvement.

Meanwhile, the Mortgage-backed Securities (MBS) market in Korea developed substantially in the last five years and is considered an important product type that leads the current real estate finance market. In 2019, Residential Mortgage-backed Securities (RMBS) contributed 54% of total ABS issuance and are expected to grow steadily with the support of government policy. In this paper, with the highlight of today's RMBS market in Korea, the structure and market of MBS are discussed.

1.0 Chapter 1: Real Estate Finance History in Korea

1.1 Before 1998, Asian Financial Crisis

Before the Asian Financial Crisis in 1998, the real estate market in South Korea was substantially closed and inactive, mainly due to the government policy prioritizing the balanced supply and preventing speculative investment. As stated in *Real Estate Finance Status and Challenges in the Korean Market*, in those days, Korea suffered from a chronic supply shortage of housing and unequal distribution of real estate assets between social classes. Since this social discrepancy got worse during that time, the government's main policy toward the real estate market was to regulate and deter inflation of real estate. Thus, bank loans for real estate development were strictly prohibited unless the development was related to affordable housing, manufacturing facilities, or infrastructure.

Foreign capital was also not allowed, so foreign investors couldn't acquire land or enter the Korean market. As a counteractive measure, non-institutional financing for the housing market was facilitated by private sector. However, the "informal" financing methods leaned strongly toward the housing loan market for consumers, and did not distribute the capital to all real estate sectors. In short, real estate financing in Korea before 1998 was not developed or promoted enough to flourish yet.¹

1.2 Early 2000, Opening markets after IMF

In late 1997, the Asian Financial Crisis had a huge impact on the economy of Korea as well. In real estate sectors, asset prices steeply declined for all product types, causing many households and developers to file for bankruptcy. As a way of overcoming such distressed circumstances and eventually promote the economy again, government policy changed to a

¹ Korea Development Institute. (2012). *Real Estate Finance Status and Challenges in the Korean Market*. Korea Development Institute. (p. 3)

whole different direction from the conservative policy before the crisis. The Korean government applied an extensive revision and restriction relief to all financial sectors in an effort to encourage the economy to thrive.

As shown in Table 1, one notable policy change in the real estate sector was that bank loans, which had been strictly prohibited for non-public development before IMF intervention, were eased in 1998, allowing various real estate products (e.g. office and retail, mainly developed for generating income) to benefit from them.

Table 1 - Real estate related policy changes before/after IMF²

Year	Related Act/Policy	Content
1996	A partial opening of domestic real estate service market to foreign firms	Allowing foreign service firms to provide brokerage, appraisal, or property management services
1998	A total opening of domestic real estate service market to foreign firms	Allowing foreign service firms to provide self-leasing, self-sales, or development
1998	Revision of “Foreigner's Land Acquisition Act”	Allowing foreign entity land acquisition
1998	Legislation of “Foreign Investment Promotion Act”	Providing tax treatments to foreign entities
1998	Revision of “Loan Management Act”	Allowing bank loans for housing, commercial real estate
1999	Legislation of “Asset Securitization Act”	Introduction of ABS (Asset-Backed Securities)
2000	Legislation of “Real Estate Investment Company Act”	Introduction of K-REITs
2003	Legislation of “Indirect Investment vehicles Act”	Introduction of real estate fund

On top of the big change in the “Loan Management Act,” remarkable changes during this period include:

- 1) Development of modernized financing (Initiation of securitization)
- 2) A complete opening of market to foreign capital and real estate firms
- 3) Change in real estate asset valuation concept

² Korea Development Institute. (2012). *Real Estate Finance Status and Challenges in the Korean Market*. Korea Development Institute. (p. 6)

In terms of the first modernized real estate financing in Korea, ABS (1999) and REITs (2000) were also adopted during this period in an effort to diversify financing methods. The first government Mortgage-backed Securities (MBS) was also issued in 2000. Furthermore, it was during this time when Korea opened the real estate market to all potential foreign investment firms. According to a revised “Landownership of Foreign Entities Law” in 1998, all foreign entities could acquire land for investment purpose. Multiple Korean corporations sold their real estate assets to foreign investors after the restriction relief, and it eventually brought in foreign capital and investment vehicles as well as real estate service firms to the Korean market. This led to a substantial development of the commercial real estate market in Korea, and eventually changed the overall asset valuation from “capital gain” to “income approach” as well. Before 2000, capital gains from asset price change, depending mainly on expected market growth, was the prevailing appraisal method in Korea. But with the influx of foreign capital, the principle method of real estate appraisal changed to “income approach” that was more commonly used by foreign firms. Income approach considers the future cash flow as the most important factor deciding current value. Thus, it also changed the prevailing practice in assessing mortgages, so that the modernized project financing which highly depended on future revenue of the project would be facilitated afterwards.

1.3 After 2008, Global Financial Crisis (GFC) and market downturn

Due to the active promotion policy of government and low interest environment after the Asian Financial Crisis, the real estate sector saw dramatic growth in Korea, involving an increased number of housing and commercial real estate developments. It also led to the development of structured real estate finance, and diversification of financing vehicles. However, with the rapid economic boom, the other side of the economy saw uncontrolled problems accumulated from the mid-2000s. According to *Real Estate Finance Status and*

Challenges in the Korean Market, there was a concern about over supply of housing and poorly managed loan originations from thoughtless developments. These problems peaked in 2008, during the Global Financial Crisis. As shown Figure 1, many projects that were expecting a huge success in a developer-favorable market in the mid-2000s failed to project market demand. Vacancy rates had increased and peaked in 2008, leaving many housing units unsold.

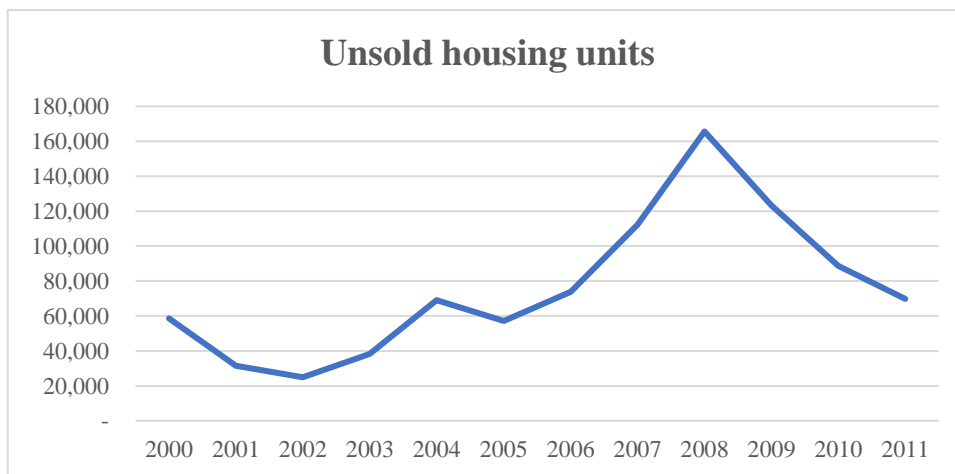

Figure 1 - Total unsold new housing units in Korea³

Thus, multiple real estate development projects solely depending on market growth were suspended, causing all relevant project financing loans to default. It led to a mass bankruptcy of financing participants such as investment firms and general contractors after 2008. Especially, the huge impact on those general contractors, who were usually forced to guarantee the project loan on behalf of small developers, resulted in the paradigm change in project financing, which will be covered in Chapter 3.

However, despite all the impact on real estate related firms, the GFC did not have much impact on consumers' aspect such as the housing mortgage market compared to the circumstances in the US market, mainly because, even with increased housing supply and

³ Statistics Korea (<http://kostat.go.kr/>)

vacancy rates, the overall housing price was not too volatile to cause the default of the mortgage loans. Moreover, housing mortgages were strictly managed by government in terms of Debt-to-Income (DTI) and Loan-to-Value (LTV), under the consistent policy to manage the market price volatility and prevent speculative investment.⁴

1.4 Recent Real Estate Market Trend

As stated in previous sections, the domestic real estate market has been through multiple troughs and peaks that are highly correlated with an overall economic situation and the counteractive government policies. Recently, the direct contribution of new domestic construction and real estate development has kept decreasing, often indicated as a substantial oppression for economic growth recently. Compared to the previous prosperous eras, there are surely not many domestic opportunities for the real estate sector. As shown in Figure 2, the contribution of construction to the real estate related field has been decreasing.

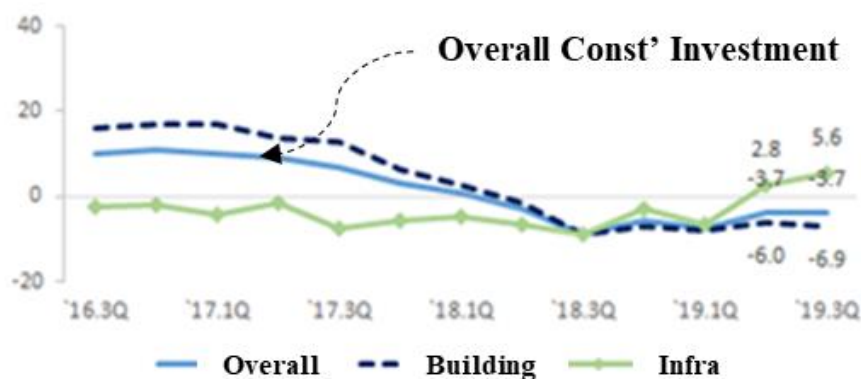

Figure 2 - Direct investment on Construction sector⁵

On top of that, due to the steady low interest environment, multiple domestic investors

⁴ Korea Development Institute. (2012). *Real Estate Finance Status and Challenges in the Korean Market*. Korea Development Institute. (p. 9)

⁵ Korea Appraisal Board Real Estate Research Center. (2019). *Real Estate Market Trend Report 19-20*. Korea Appraisal Board.

interested in the foreign real estate market have increased as a new way of maintaining their returns. Thus, the most prominent change during mid-2010s in real estate investment trends in Korea is that many domestic institutional investors, investment banks, and insurance companies have been diversifying their investment portfolios by regional variations. According to Real capital analytic (RCA), Korean institutional investment firms invested in commercial real estate totaled USD 170 billion in 2019, the largest amount invested in international assets in Asia. In the last two years, Korean institutional investors make up approximately 50% of total Asian capital invested in foreign assets.

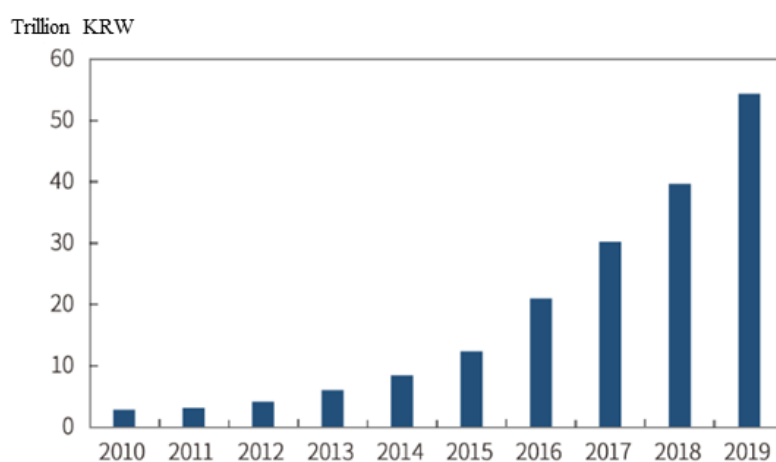

Figure 3 - Real Estate Fund Amount on international assets⁶

As seen in Figure 3, the total fund amount invested in international real estate has been growing steeply by 19-fold in the last ten years, from 2.3 billion USD in 2010 to 45.1 billion USD in 2019. During the same period, one of the biggest Korean institutional investment firms, National Pension Service (NPS) has increased their investment amount by 6-fold from 4 trillion KRW to 23 trillion KRW.⁷ Moreover, as another way of

⁶ Korea Capital Market Institute Research Center. (2020). International Real Estate Investment Trend Report. *Korea Capital Market Institute*.

⁷ Korea Capital Market Institute Research Center. (2020). International Real Estate Investment Trend Report. *Korea Capital Market Institute*.

diversification, investors are now seeking various securitization methods. Many investors found a previous trend of owning physical real estate assets risky and hard to liquidate, especially when assets are internationally located. Modernized real estate related securitization has been popular because of this, enabling many investors to allocate their money throughout a variety of securities. A series of recent trend changes prove that the development of investment methods throughout the previous financial crisis, from traditional asset-based investment to various modernized securities, funds, and structured loans, paved the way for domestic investors to participate in the global real estate market

2.0 Chapter 2: Real Estate Securitization

2.1 Definition and purpose

In general, securitization is to convert assets into securities, usually for the purpose of raising capital by selling them to other investors. Nowadays, modern securitization involves aggregating cash-flow-generating assets as opposed to the sale of individual assets. Securitization enables the transformation of a portfolio of financial assets (contractual debt) into marketable securities that have differing risk profiles from the original underlying assets.⁸ Mortgages were the traditional collateral used in securitizations; however, as the market evolved, a wider array of assets have been securitized, the most common of which include auto loans, credit card receivables, student loans, corporate loans and negotiable financial instruments, such as bonds and other debt contracts.⁹ In the category of real-estate-related securitization, securities having underlying assets, such as real estate mortgage or real estate itself, could be included such as Mortgage-Backed Securities (MBS), Project Financing Bonds, and in a broader concept, REITs and real estate funds.

By securitization, the asset owner is able to finance in a more diverse way with lower origination cost by selling securities that are exclusively linked to a legally separated entity, a special purpose vehicle (SPV). The cash flows were originated (“underwritten”) by a financial intermediary, which sold the rights to the cash flows to the special purpose vehicle.¹⁰ Thus, often the SPV having a higher credit rating than the original asset owner enables lower financing cost since securitization grants the owner of the riskier asset easier access to the

⁸ Saleuddin, R. (2015). *Regulating Securitized Products: A Post Crisis Guide*, Basingstoke: Palgrave Macmillan.

⁹ Fender, I., & Mitchell, J. (2009). The Future of Securitisation: How to Align Incentives. *BIS Quarterly Review*.

¹⁰ Gorton, G., & Metrick, A. (2013). Securitization. In *Handbook of the Economics of Finance* (Vol. 2, pp. 1-70). Elsevier.

capital markets as Asset-Backed Securities (ABS) ratings are usually higher than—and do not depend on—the rating of the originating entity.¹¹ Moreover, securitization can be financed off-balance-sheet, giving an opportunity for diverse financing for the asset owner. It also mitigates the drawbacks of overreliance on a single or few funding sources, especially during periods of scarce market liquidity.¹²

Most importantly, as real estate is a highly illiquid asset, securitization plays an important role in improving the asset owner's liquidity position as securitization converts assets ultimately into cash. Due to this advantage, securitization in the real estate industry is constantly growing and evolving globally.

2.2 Securitization Structures

Though structures may vary slightly among different types of securities, depending on the underlying asset, participants and flow are usually structured similarly. To quote *Securitization: Past, Present and Future*, the process of securitization of standard ABS can be defined in five phases: ¹³

1. The originator establishes the SPV, aggregates the collateral pool and conveys the assets to the SPV via an assignment.
2. Bonds (ABS) backed by the asset pool are tranching into classes, rated and then sold to investors.
3. The SPV funds the purchase of the underlying assets with the proceeds of the sale.
4. Repayments from the underlying assets are used to make coupon payments to

¹¹ Choudhry, M., Moskovic, D., Wong, M., Baig, S., Liu, Z., Lizzio, M., & Voicu, A. (2014). *Introduction to Securitisation and Asset-Backed Securities. Fixed Income Markets: Management, Trading, Hedging*, Second Edition, No. 261–296.

¹² Choudhry, M., Moskovic, D., Wong, M., Baig, S., Liu, Z., Lizzio, M., & Voicu, A. (2014). *Introduction to Securitisation and Asset-Backed Securities. Fixed Income Markets: Management, Trading, Hedging*, Second Edition, No. 261–296.

¹³ Deku, S. Y., & Kara, A. (2017). *Securitization: Past, Present and Future*. Springer International Publishing. (p.10)

investors.

5. All cash flows from the underlying assets are used to redeem the tranches by making principal payments during the final amortization period. (Figure 4)

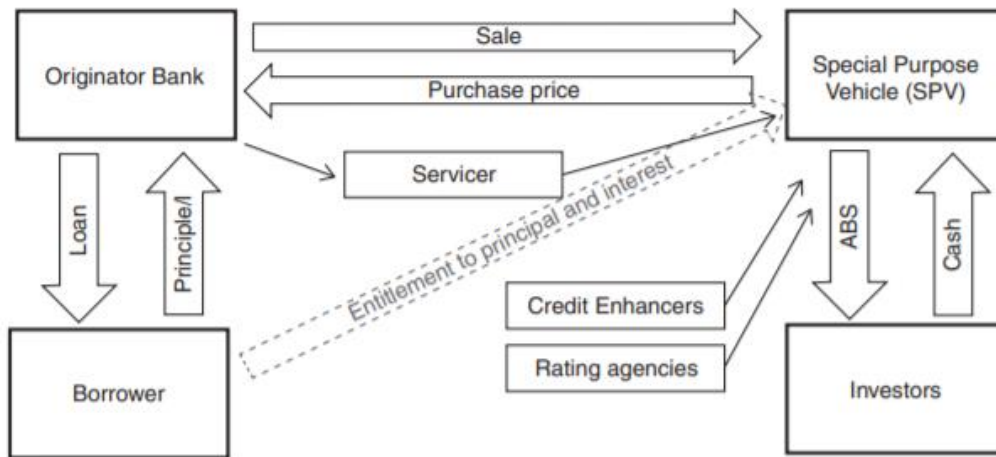

Figure 4 - Securitization Structure¹⁴

Securitization can also be used as a vehicle to raise funds and to transfer credit risk. This process involves a number of parties; however the key roles are dominated by banks. The main actors in a typical transaction are originator, underwriters, rating agencies, servicers, and trustees. The role of each participant, referring to *Securitization: Past, Present and Future*, is as follows:¹⁵

1. The originator (also known as the sponsor, issuer or seller) is responsible for generating the assets required for the transaction. This is likely to be a bank or a specialty lender as securitization is an avenue to dispose of their assets. This institution advances loans or mortgages to borrowers (obligors).

2. Servicers are tasked with the administering the credit and collection policy as stipulated in the pooling and servicing agreements. They are also responsible for the loss

¹⁴ Deku, S. Y., & Kara, A. (2017). *Securitization: Past, Present and Future*. Springer International Publishing. (p.10)

¹⁵ Deku, S. Y., & Kara, A. (2017). *Securitization: Past, Present and Future*. Springer International Publishing. (p.11)

recoveries. The servicer reports on the performance of the portfolio as well as the status of collections on a regular basis to the issuer.

3. A trustee is an independent firm appointed by the issuer to represent investors. The trustee has a fiduciary responsibility of administering the SPV and representing the interests of investors. The main duty of the trustee is to disburse payments to investors and to verify the performance of the asset pool based on information provided by the issuer and servicer.

4. The underwriter, typically an investment bank, is charged with analyzing investor demand, structuring and marketing the issue. The structuring process involves allocating the pool risks into tranches. The underwriter also provides liquidity support by acting as a broker-dealer/market maker since ABS are traded over the counter.

2.3 Real Estate Securitization product type

MBS (RMBS, CMBS)

Mortgage-backed Securities (MBS) typically refers to the securities backed by pools of mortgages. These could be backed by residential mortgages (RMBS) or commercial mortgages (CMBS).

RMBS could be backed by either prime or subprime residential mortgages. According to *Securitization: Past, Present and Future*, prime mortgages are typically offered by high street lenders to high quality borrowers. Subprime mortgages are mortgage loans granted to less creditworthy borrowers who would not qualify for regular mortgages.¹⁶

In the States, the development of RMBS market is closely related to the federal government's effort to develop the secondary mortgage market. With the involvement of the Federal National Mortgage Association (FNMA), the Government National Mortgage

¹⁶ Deku, S. Y., & Kara, A. (2017). *Securitization: Past, Present and Future*. Springer International Publishing. (p.42)

Association (GNMA), and the Federal Home Loan Mortgage Corporation (FHLMC), the residential secondary mortgage market has become one of the largest asset-backed securities markets in the US.

CMBS are bonds backed by pools of commercial properties that generate cash flow and are used primarily for commercial purposes, such as retail, office, hotels, and multifamily housing.

The overall concept of CMBS is similar to that of RMBS, except the underlying asset is either housing mortgage or commercial mortgages. To quote *Commercial real estate Analysis and Investments*, CMBS securities provide claims to components of the cash flow coming from the underlying mortgages as the borrowers pay their interest and principal obligations. As shown in figure 5, Mortgage loans on individual commercial properties originated by lenders in the primary market are pooled together, usually by an investment banking firm, and transferred to a trust. The trust then issues and sells a number of classes of bonds to investors to complete the securitization of relatively illiquid mortgage loans into securities, most of which can be relatively liquid (similar to the corporate bond market).¹⁷

¹⁷ Geltner, D., Miller, N. G., Clayton, J., & Eichholtz, P. (2014). *Commercial real estate analysis and investments*. OnCourse Learning. (p 482)

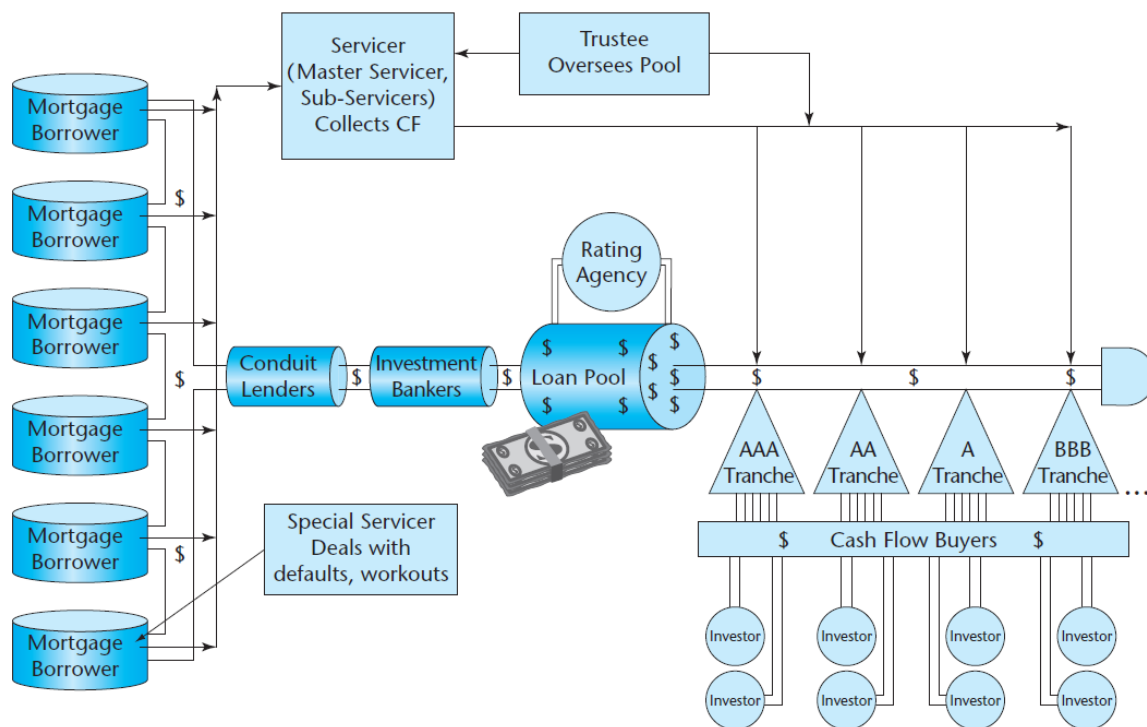

Figure 5 - CMBS securitization process¹⁸

Project Finance ABS (Project Finance Bonds)

Project Finance ABS is a type of securitization with an underlying asset as a Project Finance loan on assets such as real estate, infrastructure, or certain kinds of cash-flow-generating illiquid assets. Project Finance loans consider future cash flows of an asset. When evaluating the asset value, the feasibility and profitability of an independent project which usually forms a special purpose entity are the main concern, not the credit rating of parent companies.

For a better understanding of the term Project Finance, it could be clarified according to Basel II rules by the Basel Committee on Banking Supervision;

“Project finance is a method of funding in which the lender looks primarily to the revenues generated by a single project, both as the source of repayment and as security for the

¹⁸ Geltner, D., Miller, N. G., Clayton, J., & Eichholtz, P. (2014). *Commercial real estate analysis and investments*. OnCourse Learning. (p 483)

exposure. This type of financing is usually for large, complex and expensive installations that might include, for example, power plants, chemical processing plants, mines, transportation infrastructure, environment, and telecommunications infrastructure. Project finance may take the form of financing of the construction of a new capital installation, or refinancing of an existing installation, with or without improvements. In such transactions, the lender is usually paid solely or almost exclusively out of the money generated by the contracts for the facility's output, such as the electricity sold by a power plant. The borrower is usually an SPE (Special Purpose Entity) that is not permitted to perform any function other than developing, owning, and operating the installation. The consequence is that repayment depends primarily on the project's cash flow and on the collateral value of the project's assets."

Once the asset to be assessed is set according to the definition and standard of project financing, securities as a form of bonds are issued.

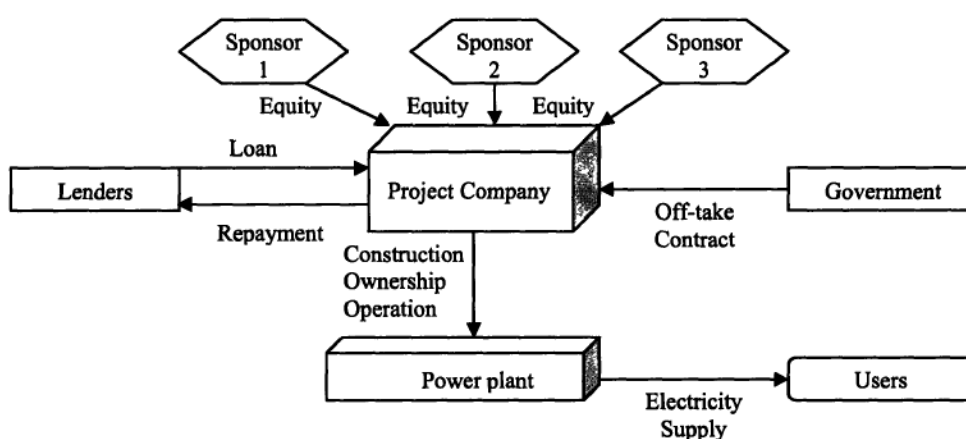

Figure 6 - Project Finance Structure¹⁹

As shown in Figure 6, assuming a project is a power plant, then the revenue from sales of the electricity to end users is the future cash flow. A borrower is a project company itself,

¹⁹ Patramanis, T. (2006). *Structure finance for hybrid infrastructure models: the application of project finance into public-private partnerships for the construction and operation of infrastructure* (Doctoral dissertation, Massachusetts Institute of Technology). (26p)

and a loan is being securitized as bonds and sold in a market for investors.

REITs

REITs are real estate firms, with assets and activities largely restricted to real estate. In a broader concept of securitization, REITs could also be considered a liquidation of real estate assets. Referring to *Commercial real estate Analysis and Investments*, publicly-traded equity REITs are companies that own, and in most cases manage, portfolios of properties. The concept of REITs was first created by Congress in 1960, but it was in the 1990s that REITs became a major player in the commercial real estate property market. As well as CMBS market, the public REITs market grew tremendously with the securitization revolution of the 1990s.

Shares of publicly traded REITs are traded in the stock market in a similar way to other types of stocks, giving them high liquidity of real estate assets. From this idea, small individual investors are able to own the part of real estate property by purchasing REITs. The biggest difference between typical stocks and REITs is that REITs are exempt from corporate income tax. REITs have tax advantages similar (though not identical) to pass-through entities such as mutual funds and partnerships, while retaining the limited liability afforded by the corporate ownership form. However, there are a few regulatory conditions when deciding a company is a REIT, a passive investment vehicle specialized in real estate, as follows:

1. Ownership Test: A REIT cannot be a closely held corporation, in the sense that no five or fewer individuals (and certain trusts) may own more than 50 percent of the REIT's stock, and there must be at least 100 different shareholders.

2. Asset Test: Seventy-five percent or more of a REIT's total assets must be real estate, mortgages, cash, or federal government securities, and 75 percent or more of the REIT's yearly gross income must be derived directly or indirectly from real property (including mortgages,

partnerships, and other REITs).

3. Income Test: REITs must derive their income (at least 75 percent) from primarily passive sources like rents and mortgage interest, as distinct from short-term trading or sale of property assets.

4. Distribution Test: At least 90 percent of a REIT’s annual taxable net income must be distributed to shareholders as dividends each year.²⁰

2.4 Securitization Market History and trend

Global Market History and Trend

The securitization industry was born in 1970 in the United States with the residential home mortgages by the Government National Mortgage Assocation (GNMA). The market expanded throughout afterwards with the emergence of asset-backed securities in 1980, and the commercial real estate asset-backed securities in 1990.

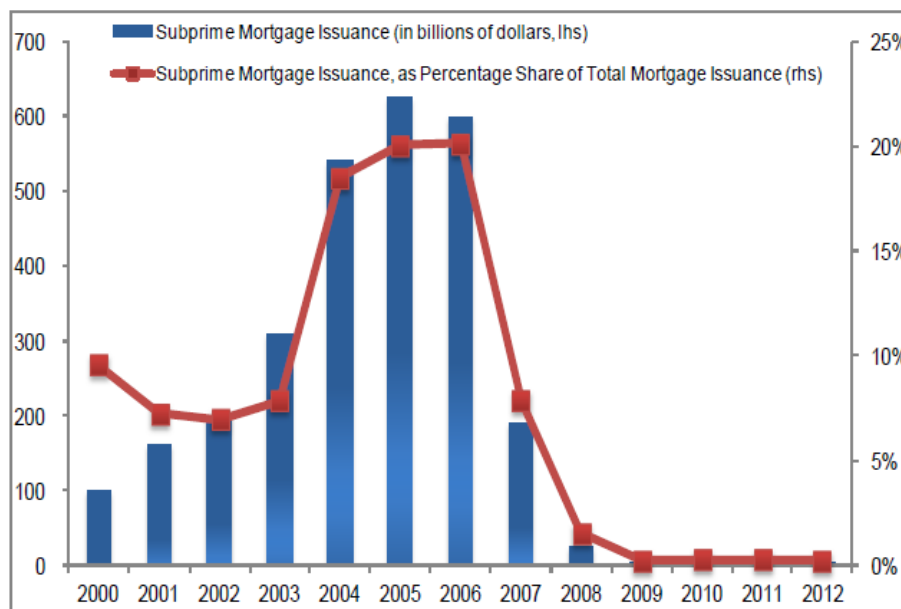

Figure 7 - US subprime mortgage issuance²¹

²⁰ Geltner, D., Miller, N. G., Clayton, J., & Eichholtz, P. (2014). *Commercial real estate analysis and investments*. OnCourse Learning. (p 576)

²¹ Miguel Segoviano, Bradley Jones, Peter Lindner, and Johannes Blankenheim. (2013). *Securitization:*

According to figure 7, in the early 2000s, the market continually grew, but there was accumulated risk in the RMBS market as the subprime share of total US mortgage origination increased dramatically from a low of 6.9 percent in 2001 to a peak of 20.1 percent in 2006.

The major problem with the mortgages issued during that time was that they were usually adjustable-rate mortgages, which meant that borrowers were heavily exposed to volatile interest rates as well as principal payment shocks at the reset times. Moreover, the emergence of private players (outside of the two government-sponsored enterprises (GSEs), Fannie Mae and Freddie Mac, and Ginnie Mae) as a new force in MBS issuance was associated with a sharp decline in lending standards over this period.²² Eventually, the poor management of risk and a large issuance in the subprime market led to the Global Financial Crisis (GFC) in 2008.

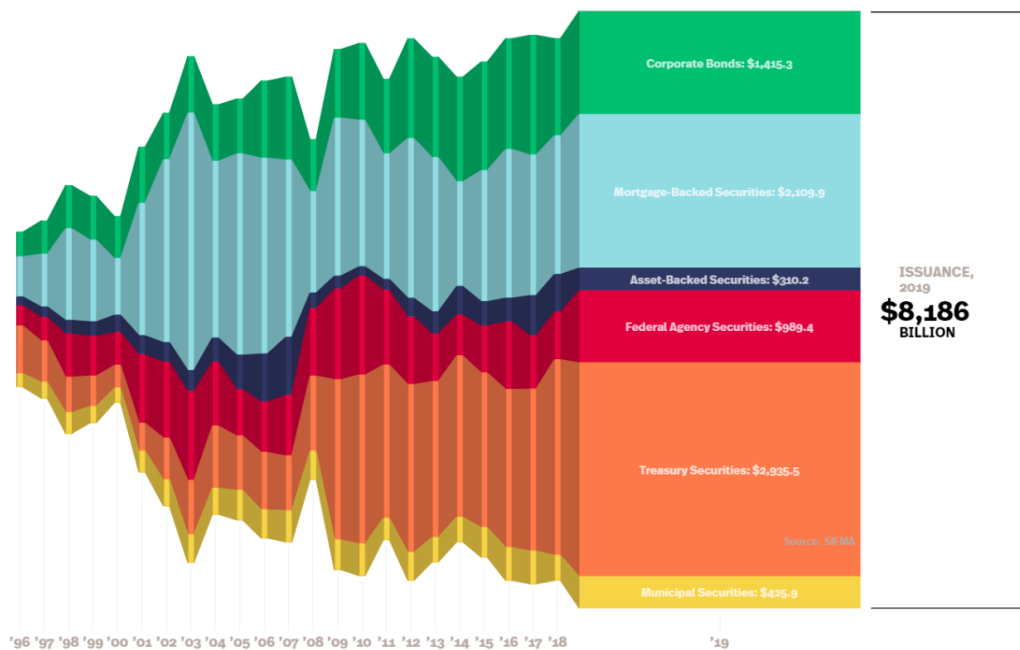

Figure 8 - U.S ABS issuance²³

Lessons Learned and the Road Ahead. *International Monetary Fund*.

²² Miguel Segoviano, Bradley Jones, Peter Lindner, and Johannes Blankenheim. (2013).

Securitization: Lessons Learned and the Road Ahead. *International Monetary Fund*.

²³ Sifma.org

Though the subprime mortgage market directly had an impact on the GFC, the general trend line in the securitization market has been pointing upward since then. As shown in Figure 8, there had been a steep decline in the market size during and after GFC, but it quickly peaked in the following years. ABS issuance in the states had been growing and peaked in 2019, with the total issuance of \$8,186 billion.

In a broader perspective, according to an S&P report in 2020, the global structured finance markets, which often involve the process of securitization, have been growing steadily in the last four years. In 2019, over \$1.1 trillion of structured finance vehicles were issued across the globe, especially higher new issue volumes in the US, China, Australia, and Latin America than before. As shown in Figure 9, real-estate-related securities such as RMBS and CMBS still play a significant role in the United States. The development of securitization in the Asia-Pacific region, especially in China, has shown a striking increase, and thus contributes a large portion in global total issuance of structured finance volumes.

Global Structured Finance Volumes(i)						
	2015	2016	2017	2018	2019	2020 forecast
U.S. (bil. \$)						
ABS	183	191	229	239	244	240
CMBS	95	69	88	77	96	100
CLO	98	72	118	129	118	90
CLO reset/refi	10	39	167	156	43	40
RMBS-related	54	34	70	95	124	130
Total U.S. new issue(ii)	436	373	510	540	582	560
Canada (bil. C\$)	15	18	20	25	19	20
Europe (bil. €)	78	81	82	107	102	100
Asia-Pacific (bil. \$)						
China	97	116	220	292	334	330
Japan	38	53	48	56	55	55
Australia	24	16	36	23	31	31
Total Asia-Pacific new issue	159	185	304	371	420	416
Latin America (bil. \$)	11	12	17	9	13	15
APPROXIMATE GLOBAL NEW ISSUE TOTAL (bil. \$)	700	670	930	1,050	1,140	1,120

Figure 9 - Global Structured Finance Volumes²⁴

²⁴ Tom Schopfloch, and James M Manzi. (2020). Global Structured Finance Outlook Report 2020. *S&P Global Ratings*.

Korean Market History and Trend

The securitization market in Korea has been developing since 1998, with the initiation of ABS law. Though the concept of ABS started late compared to the global securitization industry, it has been growing at a steady pace especially with a huge contribution of MBS. After two financial crises, in 1998 and 2008, the counteractive economic stimulus policy pursued by the government promoted the market to develop. In 1998, ABS was first adopted as a way of overcoming the downturn. In the second economic crisis in 2008, as shown in Figure 10, right after the economic downturn, the issuance of securities dropped, but the degree was much less intense than what happened in the global market and the issuance amount quickly started to pick up afterwards.

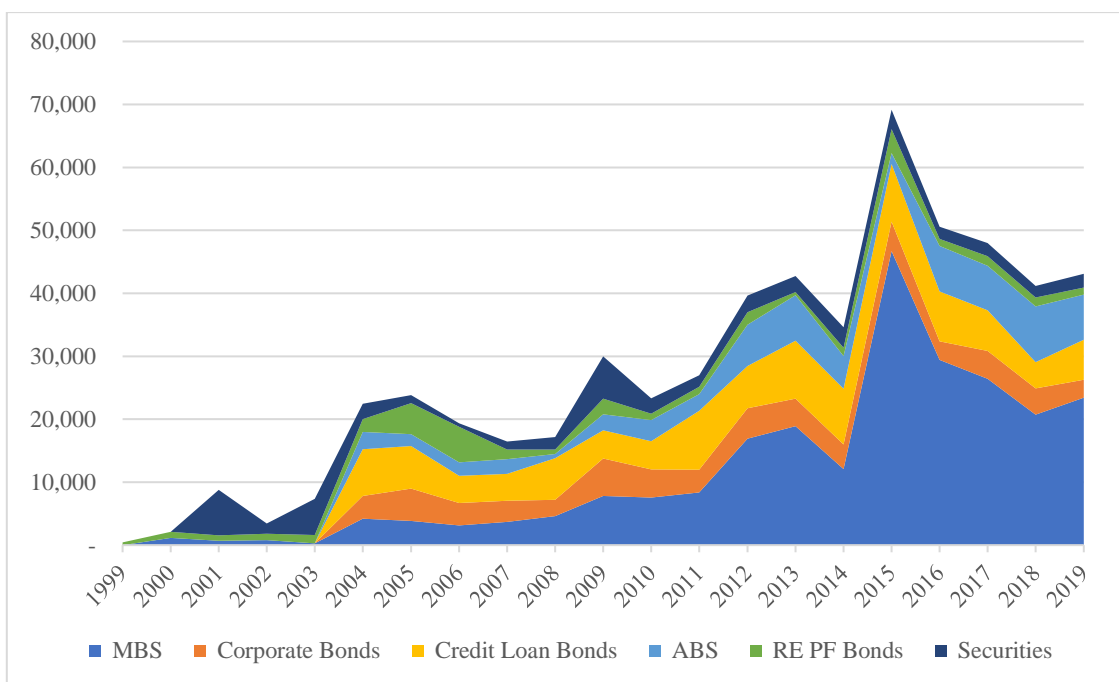

Figure 10 - Korea ABS issuance (in million USD)²⁵

The most important trend in the overall ABS market throughout history is that the MBS market has been growing dramatically since the mid-2000s. One of the remarkable

²⁵ Financial Supervisory Service (fss.or.kr)

increases was in 2015 when the total ABS issuance increased by 99.8%, mainly due to a huge issuance in MBS, which had increased by 285%. This is highly correlated to the government housing policies that tried to promote the government-guaranteed housing mortgage market. On the other hand, the RE PF (Real Estate Project Finance) Bond market had been one of the promising financing methods for construction projects until mid-2000s, but shrank mainly due to the GFC. Recently, the PF Bond has lost its glorious position in real estate financing that it had before 2008, but it is still considered an important category that builds up securitization market in Korea.

In the most recent trend, total issuance of ABS had slowed down since a big surge in 2015, but the market has shown an active ABS issuance again in the first quarter of 2020. This is due to the similar reason as in 2015, the big increase in MBS issuance by Korea Housing Finance Corporation, as the promotion of affordable housing loans and the increased market demand for such loans.

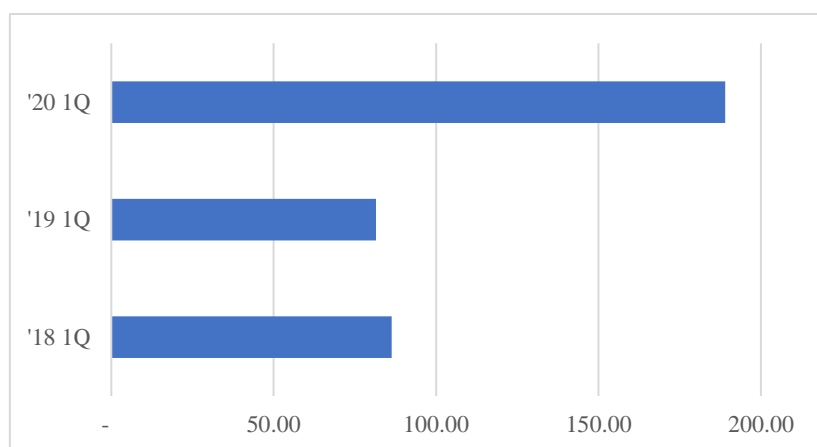

Figure 11 - First Quarter ABS issuances in the last 3 years²⁶

In the first quarter in 2020, the MBS issuance amount was 17.9 trillion KRW, which increased by 274% from the issuance of the first quarter in 2019, 4.7 trillion KRW. Though the

²⁶ Financial Supervisory Service (fss.or.kr)

market size of ABS in Korea is still relatively small compared to other big global markets, the market has been developing in size and diversification and clearly has become one of the most important financing methods.

3.0 Chapter 3: Project Finance Asset-Backed Securities (PF ABS/Project Bond)

3.1 Project Finance Loans

3.1.1 Overview of Project Finance Loans

As defined in Chapter 2, a Project Finance loan (PF loan) is the underlying asset for Project Finance Asset-Backed Securities (PF ABS). According to the *Principles of project finance*, a PF loan is a debt-financing method usually related to the construction of hard assets such as buildings, infrastructure, or any kind of cashflow-generating real estate. Due to the long construction period and long operation life of assets, a PF loan usually has a long term (e.g., 15-25 years).

The borrower is typically a special-purpose legal entity (usually a limited company) whose only business is the project (Project Company). The project itself must be economically feasible to amortize the loan because future cashflow to be generated by the project is the main source to pay off the interest, fees and principal of the PF loan. Therefore, when evaluating the asset value, the profitability of an independent project formed by a special-purpose legal entity is the main concern. A PF loan is also a “non-recourse” loan without any guarantee from the participants in the project, requiring lenders to carry out a detailed analysis of the project’s risk before origination. Thus, a PF loan differs from corporate finance, where loans have access to the corporate-level cashflow not limited by a specific project.²⁷

3.1.2 Features of Project Finance Loans in Korea

Though the PF loan market in Korea has decreased in size since the Global Financial Crisis, a PF loan still contributes to the real estate financing market, especially for a large-sized project involving the public sector. In Korea, the concept of a PF loan was first adopted for the

²⁷ Yescombe, E. R. (2013). *Principles of project finance*. Academic Press.

purpose of financing long-term infrastructure projects in the developing period in the 1990s. The general framework and policy were set with the initiation of the 'Private Financing for Infrastructure Promotion Act' in 1994, facilitating the Incheon International Airport Highway to be structured with a project finance loan in 1995. With the rapid growth rate and promotion of construction all over Korea, the PF loan expanded fast from public infrastructure projects to the private sector of real estate such as housing and commercial buildings. Since then, PF loans have been a popular financing method in Korea because they provide high returns to the lenders and do not affect the balance sheet of the parent company which forms the project company.

The PF loan has evolved in a unique way in Korea, somewhat modified from the international standard. As defined previously, a PF loan should be appraised solely by the profitability and future cashflow of the project company, and not affected by participants' credit ratings. Moreover, it is a non-recourse loan not impacting other participants except the project company. However, it was a common practice in Korea for PF loans to be guaranteed by the general contractor, with the lender claiming recourse to the general contractor if the project fails. It is indeed an abnormal structure of a PF loan that the responsibility of the project company is entirely moved to one of the participants in a project.

This is mainly caused by a distinctive role allocation among development project participants. In Korea, the developer is usually considered merely an initiator of a project, mainly focused on the early stage of development such as land acquisition, permit process, and leading a bid for general contractor. After the general contractor is selected, the general contractor typically leads the project, and the role of the developer is highly limited from this point. A main reason for this role allocation could be the small size and insufficient capacity of the developers in Korea. Developers are usually small and usually do not possess enough human resources to lead the whole project. Moreover, due to the financial insufficiency, developers normally cannot contribute equity, and thus sometimes their motivation to

guarantee the success of the whole project is limited. Thus, many developers in Korea have limited roles compared to developers in the US, where it is common that developers technically play an active role in the project company. In contrast, the general contractor's duty is heavier in Korea. Besides the general contractor's typical responsibility of guaranteeing the completion of the project for the developer, it is obligated to guarantee a PF loan. It is structured that lenders originate a PF loan for a project company, but the condition of the loan often requires the general contractor to guarantee a loan by a form of credit enhancement on behalf of the developer who typically does not have the ability to provide mortgage or guarantee.

3.1.3 Crisis of Project Finance Loans in Korea

The PF loan structure that puts too much responsibility on general contractors caused a mass bankruptcy of general contractors and investment banks in 2008. During the market downturn in the Global Financial Crisis, many projects were suspended or didn't turn out to be profitable enough to pay the debt and all related PF loans defaulted. Many general contractors who guaranteed loans and lenders who relied on general contractors' credit rating and hadn't evaluated the projects thoroughly went bankrupt. This brought the need of alternative risk management of PF loans and a restriction on thoughtless loan origination, but not much was achieved even after that.

This unsolved problematic market condition consequently led to another PF loan crisis in 2011. In 2009, as a lot of second-tier banks seeking a higher return started to invest a substantial amount of capital in the real estate sector, the evaluation of PF loans became too relaxed, leading them to lend to even risky projects. The overheated investment in PF loans eventually caused a massive volume of non-performing loans, deteriorating second-tier banks' financial status. Thus, it led the Financial Services Commission (FSC) of Korea, to suspend the business of seven insolvent banks for six months and accelerate the consolidation

of strict policies on ABS issuance in 2011. This measure also led to new participants in the PF loan market, such as securities companies and insurance companies, to fill the vacant lender position occupied by second-tier banks before.

3.2 Securitization of Project Finance Loans

3.2.1 Overview of Project Finance Asset-Backed Securities (PF ABS/Project Bonds) in Korea

Project Finance Asset-Backed Securities are backed with PF loans and are usually referred to as Project Finance Bonds or Project Bonds in the global market. In Korea, Project finance securities are typically called Project Finance Asset-Backed Securities (PF ABS) or Project Finance Asset-Backed Commercial Paper (PF ABCP) depending on the issuance condition. In addition to those two products, a PF loan that is securitized by a Real Estate Fund could also be included in this category under a wider definition.

The overall structure is almost identical for PF ABS and PF ABCP, but there are a few differences distinguishing the two product types, such as the type of issuance company, maturity, and applicable law. According to *Real Estate Finance Status and Challenges in the Korean Market*, PF ABS is a type of bond controlled by the ‘Asset-Backed Securitization (ABS) Act’. It is also allowed to be issued by a Special Purpose Company (SPC) that is authorized by the ‘ABS Act’. In contrast, PF ABCP is a type of commercial paper and any company established under commercial law can issue a PF ABCP. Due to the difference in applicable law, PF ABS is subject to more strict regulations when issuing securities. As shown in Table 2, in the case of PF ABS, the asset owner has to register the securitization plan satisfying the ‘ABS Act’ requirement with the Financial Supervisory Service (FSS) institute. Securities can be issued only after the project company secures the ownership of the subject land for development and the cashflow of the underlying asset and PF ABS should be matched

identically. In contrast, PF ABCP doesn't require any of those restriction. In terms of maturity, PF ABS typically has a long-term maturity with a renewal option, whereas PF ABCP has a one- to three-month term and might be unable to renew depending on the financial condition of the issuance company at the point of renewal. However, PF ABCP is still considered a convenient way of refinancing during the construction project due to its less restricted nature.

Table 2 - Comparison of PF ABS and PF ABCP²⁸

	PF ABS	PF ABCP
Applicable Law	Asset Securitization (ABS) Act ⁷	Commercial Law
Issuance Entity	SPC (Special Purpose Company)	Corporate, Limited Liability Company
Underlying Asset	Project Finance Loan	Project Finance Loan
Security type	Bond	Commercial Paper
Interest Rate	Higher than PF ABCP	Lower than PF ABS
Maturity	Long-term (1-3 years)	Short-term (1-3 months)
Issuance type	Public	Private
Risk	No risk in renewal / Low risk in interest rate change	Might be unable to renew depending on financial status of company / Cost fluctuation risk for a conversion issue
Credit Enhancement	Loan assumption clause by general contractor	Loan assumption clause by general contractor / Purchase agreement by financial institution

3.2.2 Structures of Project Finance Asset-Backed Securities in Korea²⁹

A. PF ABS

PF ABS is a long-term security backed by a PF loan originated for the execution of development projects including land acquisition cost, construction cost, and other operation costs. As stated earlier, PF loans in Korea are usually guaranteed by general contractors.

²⁸ Korea Development Institute. (2012). *Real Estate Finance Status and Challenges in the Korean Market*. Korea Development Institute. (p. 151)

²⁹ Korea Development Institute. (2012). *Real Estate Finance Status and Challenges in the Korean Market*. Korea Development Institute. (p. 261-265)

Thus, the credit rating of ABS bonds is affected by the credit rating of the general contractor who guarantees the project and loan. Moreover, there are a few more prerequisites when issuing PF ABS as follows:

1. The company issuing securities must satisfy the establishment standard under the ‘ABS Act.’
2. The development project should have acquired land before ABS issuance.
3. The cash flow of the underlying asset should be identical to that of ABS.

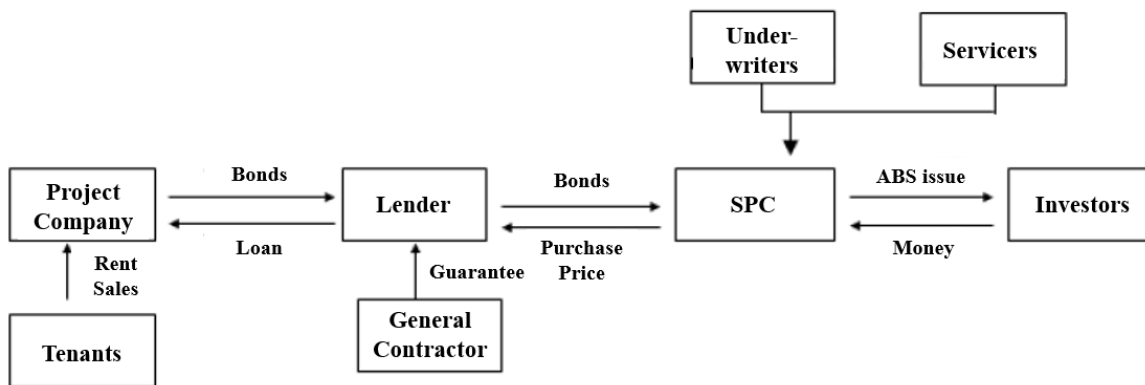

Figure 12 - PF ABS structure³⁰

As shown in Figure 12, a project company established for a single project receives a loan for land acquisition and construction from a lender, in return for their project finance bonds. Then, a lender transfers the bonds to the SPC, which satisfies the ‘ABS Act’ standard for issuing PF ABS. In the process of loan origination, the general contractor who won the bid and is expected to execute the construction of a project is required give a joint guarantee of the project. When the lender sells bonds to the SPC, there is practically no participation needed for a lender in the project finance ABS. SPC, a special purpose company established for securitization purpose, takes the bonds and sells ABS issued to multiple investors in a

³⁰ Korea Development Institute. (2012). *Real Estate Finance Status and Challenges in the Korean Market*. Korea Development Institute. (p. 262)

public market. The future cash flow generated from the project such as rent lease or sales proceeds pays off the interest to ABS investors. On behalf of the SPC, servicers and underwriters conduct the administrative work in ABS issuance. They are tasked with administering the credit and collection policy, analyzing investor demand, and structuring and marketing the issue. The SPC issuing PF ABS is considered a conduit company for a single time issuance, and thus is not required to pay corporate tax or interest income tax.

B. PF ABCP

Project Finance Asset-Backed Commercial Paper (PF ABCP) is a combined concept of ABS and Commercial Paper (CP), and is a commercial paper that is collateralized by a project company's securitized asset such as corporate bonds and sales credits. CP is generally a short-term financing method issued by high-rated companies to finance at a lower cost and conveniently securitize company assets. It is preferred when a company needs financing for a short-term period, about 90 days. In the case of financing real estate projects, ABCP issuance is mainly utilized to renew the ABS already issued by the SPC. Since a development project typically takes a long period, the project company could save financing costs by issuing ABS first and then converting ABS into ABCP, compared to the case of financing only with ABS.

In Korea, ABCP is also preferred as an alternative to ABS in some cases, when a company is unable to satisfy the prerequisite of issuing ABS. PF ABCP can be issued by any SPC established under the Commercial Law. Comparing Figure 12 and 13, the structure of PF ABS and PF ABCP are almost identical except whether the applicable law is 'ABS Act' or Commercial Law.

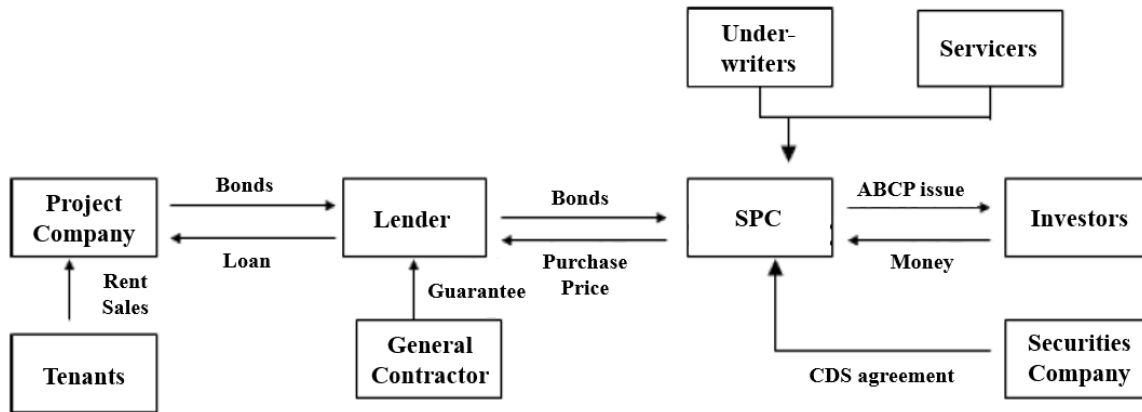

Figure 13 - PF ABCP structure³¹

A new participant is usually required in PF ABCP issuance, which is a securities company that contributes a Credit Default Swap (CDS) agreement to prevent a default of CP. A securities company agrees to buy out the remaining ABCP that is not sold in the market when there is not enough cashflow to renew the ABCP. In other words, it is a role of insurance that could guarantee the replenishment of cashflow as scheduled in a risky situation.

Unlike the SPC under the ‘ABS Act’ that is considered a mere conduit company, a company established under Commercial Law is a solid company so that it has a duty of paying corporate tax and interest income tax.

C. PF Real Estate Fund

In a broader definition, a Real Estate Fund (RE fund) is also a type of PF loan securitization. Real Estate funds have become one of the promising securitization methods since the initiation of ‘Indirect Invest Management Act’ in 2004 in Korea. A fund is formed by a fund management firm with a structure of multiple investors participating. In case of the RE Fund, more than 50% of invest money should be allocated in real estate related assets.

³¹ Korea Development Institute. (2012). *Real Estate Finance Status and Challenges in the Korean Market*. Korea Development Institute. (p. 264)

The RE fund is divided into two categories, debt or equity, depending on the assets in which they invest. A debt fund is a simple strategy mainly run by loan interest and does not manage a project by itself after a loan origination. A fund originates a PF loan that is used for land acquisition and construction and sells securities backed by the loan to investors. Figure 14 is a typical structure of a RE fund that invests in project debt.

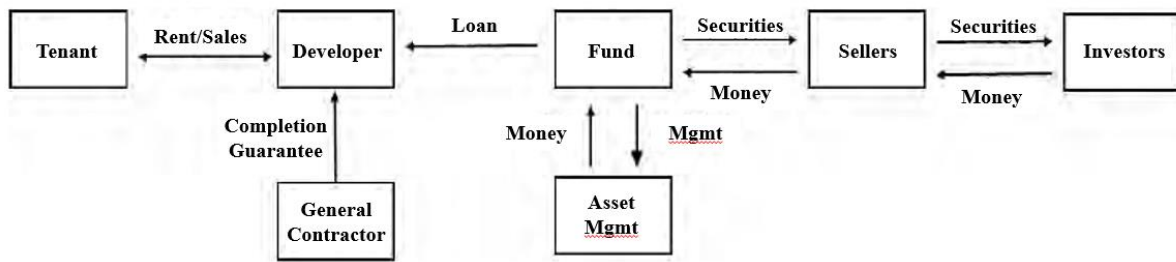

Figure 14 – Debt fund structure³²

On the other hand, funds that invest in equity require more active management of physical assets than a debt fund. These funds often acquire operating real estate assets or even develop a new asset through fund resources, and thus their return mainly comes from operating income and capital gain of the owned real estate. Depending on the asset types, a RE fund can usually be divided into four categories: Core, Core Plus, Value-add, and Opportunistic. Core and Core Plus funds are mainly focused on current income produced by the properties. A Core real estate fund is the most conservative fund that invests in a stable asset generating consistent cashflow with very low risk. A Core Plus fund also invests with a conservative strategy but looks for both income and growth with a low to moderate risk profile. In contrast, a Value-added fund acquires an asset with potential growth even if the asset is not profitable enough at the point of investment. An Opportunistic fund is the riskiest of all funds, investing in ground-up development or repositioning buildings and seeking high

³² Korea Development Institute. (2012). *Real Estate Finance Status and Challenges in the Korean Market*. Korea Development Institute. (p. 265)

return.³³ So far, RE funds that invest in debt or low-risk equity are the most preferred type in Korea.

3.3 Market Trend

3.3.1 PF ABS Market in Korea

Figure 15 shows the real estate related ABS issuance in the last 20 years. It includes both PF ABS and corporate bonds, which partially reflects PF bonds backed by Social Overhead Capital (SOC) infrastructure projects.

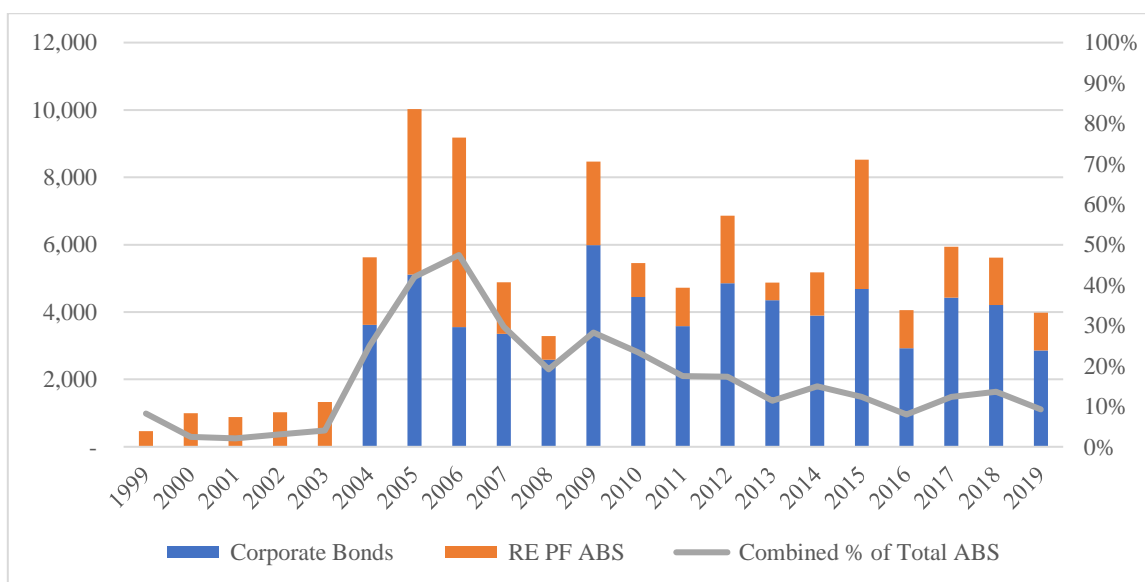

Figure 15 - Real Estate ABS issuance in Korea (in million USD)³⁴

*Corporate Bonds include SOC infrastructure PF bonds

The PF ABS market was first created with the initiation of the ‘ABS Act’ in 1999, and the market experienced a prosperous period in the mid-2000s along with the increasing popularity of PF loans. The PF loan market in Korea expanded substantially during the mid-2000s due to the real estate market upturn and economic boom. However, with the government’s effort to control the overheated real estate market in 2006, PF ABS issuance

³³ What are Core, Core Plus, Value-Add and Opportunistic Investments? (origininvestments.com)

³⁴ Financial Supervisory Service (fss.or.kr)

was prohibited for projects which had an unclear timeline for construction permits. Due to this policy, PF ABS dropped sharply in 2007, and dropped even more in the following year when the Global Financial Crisis (GFC) happened. During this period, many PF loans issued during the mid-2000s went into default, causing a mass bankruptcy of general contractors and lenders. However, with the renewed popularity of PF loans as an investment method for many banks in 2009, PF ABS increased instantly. The invested amount in PF loans by second-tier banks reached 17 trillion KRW in late 2010. Such an overheated market eventually led to a PF loan crisis in 2011, resulting in the business suspension of seven insolvent banks.

With a contracted market trend, in 2015, PF ABS showed an instant increase from PF loans for public housing projects. This did not mean the revival of PF loans and PF ABS since it was mainly impacted by government-led housing promotion in that year, aiming to increase the affordable housing supply. Many housing projects under this housing promotion policy were financed by PF loans.

More recently, PF ABS has been stagnant, whereas the market for PF ABCP has been expanding. PF ABCP is considered a popular alternative to PF ABS, since the issuance is easier and more convenient than PF ABS.

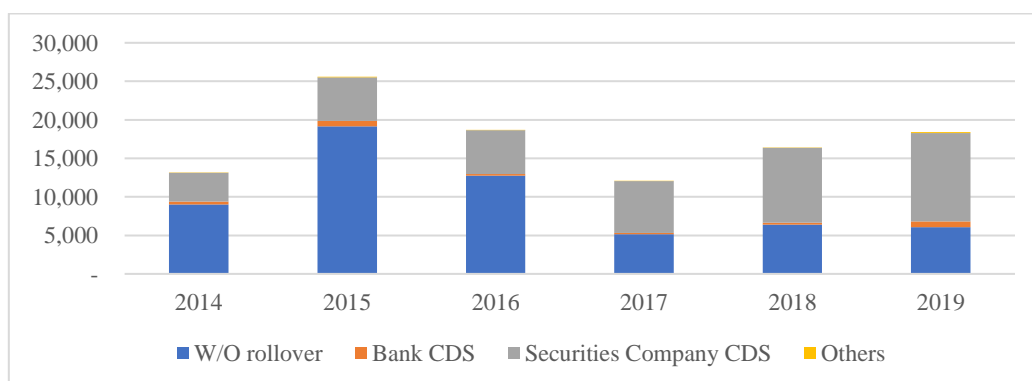

Figure 16 - Real Estate ABCP issuance in Korea (in million USD)³⁵

³⁵ Korea Ratings (<http://www.korearatings.com/>)

In 2019, PF ABCP issuance value was 18,424 million USD compared to PF ABS of 1,129 million USD according to Figure 15 and 16. However, there are a few opinions that this increasing popularity of PF ABCP should be observed carefully so as not to repeat the PF loan crisis. These opinions point out that of 18,424 million USD, 62% was agreed to offer CDS by securities company, while only less than 4% was given by large banks. As many securities companies expanded PF loans in their portfolio recently, the responsibility of them in PF ABCP have also increased. This could be interpreted as a trend of diversified participants and methods in securitization of real estate. But since the amount of CDS agreements is quite large and the contribution is mostly concentrated in securities companies, the PF ABCP market could be thought of as risky. Moreover, as a critical economic downturn has come due to Covid-19, the short-term roll-over period of ABCP compared to ABS could hit securities companies harder as many underlying projects are not expected to create cashflow in the near future.

3.3.2 Global PF ABS Market

Project Finance Asset-Backed Securities in the US usually refers to infrastructure Project Bonds with a long period of maturity, while PF ABS in Korea covers a wide range of real estate assets from small housing, to commercial buildings, to large-scale assets such as power plants and infrastructure. Project Bonds were first issued in the 1990s and have been an important source of capital for infrastructure improvement in Western Europe and North America. Today, Project Bonds are increasingly being issued to finance (in full or in part) or to refinance infrastructure programs all around the world. They are often utilized for large-scale international Public-Private Partnership (PPP) projects.³⁶ As shown in Figure 17,

³⁶ Project bonds: Their growing role in global infrastructure finance. (2014). *White&Case LLP*.

Project Bond deals were negatively impacted during and after the GFC and increased in the mid-2010s.

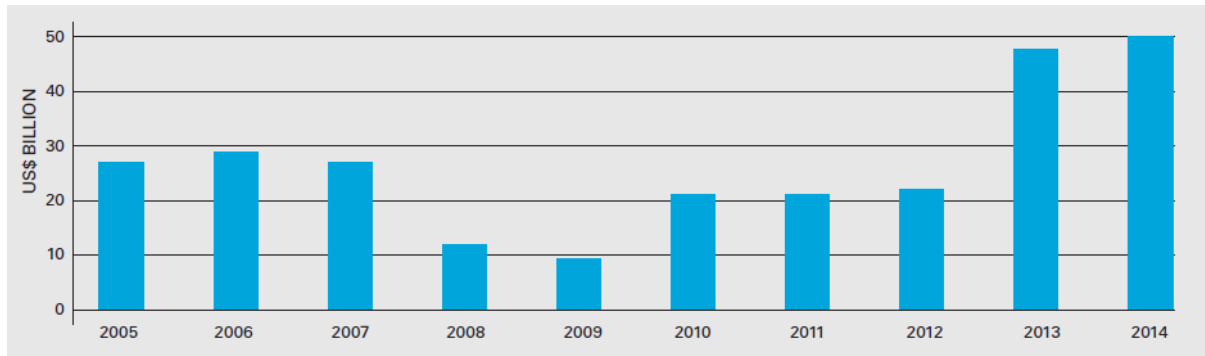

Figure 17 - Global Project Bond deals³⁷

According to Figure 18, the increase of Project Bond deals in the mid-2010s was due to a large growth in the Europe, Middle East, and Africa (EMEA) and Asia regions where many infrastructure projects have been actively built until now. In the North American region, many highway infrastructure projects were financed and securitized. Overall, Project Bonds are considered one of the prominent financing methods in construction projects globally.

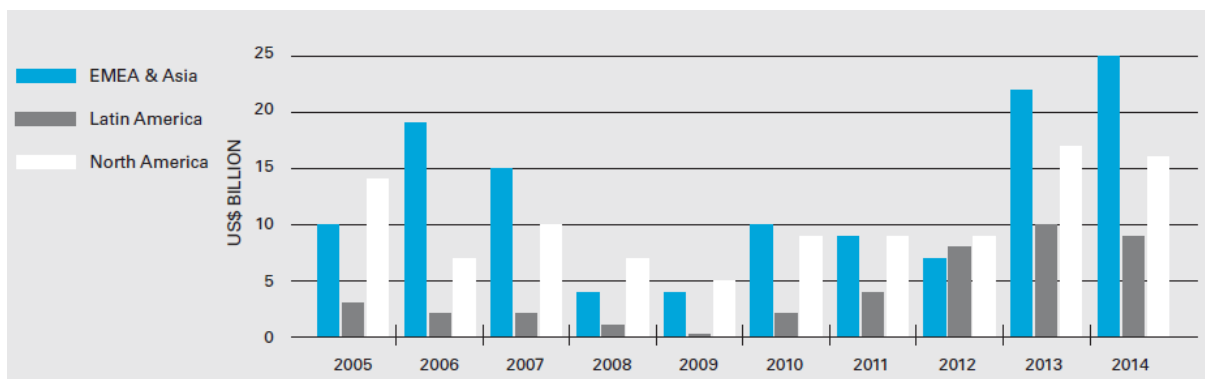

Figure 18 - Global Project Bond deals regional breakdown³⁸

³⁷ Charts extracted from White&Case. Project bonds: Their growing role in global infrastructure finance. (2014). *White&Case LLP*.

³⁸ Charts extracted from White&Case. Project bonds: Their growing role in global infrastructure finance. (2014). *White&Case LLP*.

3.4 Further Discussion for Improvement

With growing concerns regarding the soundness of PF loans and the PF ABS/ABCP market, there has been a constant discussion about improvement both in fundamental development structure and the following process of loan origination and securitization.

To improve the fundamental structure of development projects, increasing developer's equity and responsibility could be one of the methods. As discussed earlier, developers in Korea are usually small firms without enough project management capability and resources. This brings skewed risks toward general contractors and investors to guarantee the project feasibility and forms a vulnerable structure with a very low risk tolerance. Thus, requiring developers with a certain level of equity will promote their contribution and responsibility to the project and eventually redistribute risk to all participants. It will also promote projects with certainty and more eligible developers. Promoting development projects initiated by sizeable general contractors who have enough capacity is also suggested to improve the PF loan structures.

From a level of loan origination, more in-depth evaluation methods are needed. An objective and detailed evaluation of a project would enable an accurate projection of profits and cashflow. It requires focusing on an independent project's cashflow and feasibility, not solely depending on market conditions. This also includes moving away from previous credit enhancement structures by a general contractor's guarantee, because then the project evaluation is easily impacted by the general contractor's credit rating, not the independent project itself.

4.0 Chapter 4: Mortgage-Backed Securities (MBS)

4.1 Concept of Mortgage-Backed Securities (MBS)

4.1.1 Overview of Residential Mortgage-Backed Securities (RMBS) and Commercial Mortgage-Backed Securities (CMBS)

Mortgage-backed Securities (MBS) refers to the securities backed by pools of mortgages. MBS could be backed by either residential mortgages (RMBS) or commercial mortgages (CMBS). With other ABS products in Korea, MBS was introduced to the market with the initiation of the Residential Mortgage-backed Securitization Act in 1999, and the first RMBS was issued in 2000 by Korea Mortgage Corporation (KoMoCo). The RMBS market in Korea has been steadily growing since, contributing substantially to the development of real estate finance. In the contrast to the RMBS market, there has not been much issuance of CMBS so far.

Securitization for RMBS and CMBS is similar; both securities provide claims to components of the cash flow coming from the underlying mortgages as the borrowers pay their interest and principal obligations. However, as shown in Table 3, there are a few differences which derive from the traits of the underlying asset, whether it is housing mortgage pool or commercial mortgage pool.

Table 2 - Comparison of RMBS, CMBS³⁹

	RMBS	CMBS
Mortgage type	Residential mortgage pools	Commercial mortgage pools
Underlying Asset	Housings with similar standards	Commercial buildings with heterogeneous risk and cash flow
Prepayment Rate	Higher than CMBS	Lower than RMBS
Amortization	Fully amortized during loan period	Balloon payment
Market Size	Larger than CMBS	Smaller than MBS

³⁹ Edited from Byeong Jun Cho, and Bum Jin Seo. (2013). CMBS: New Real Estate Financing Method. *Korea Investors Service Ratings Report*.

In the case of RMBS, it is relatively easy to evaluate the underlying mortgage pool since housing is usually standardized by type, price and risk, whereas CMBS requires more careful evaluation because commercial buildings are not easy to analyze due to its heterogenous risk and cash flow from different buildings. The prepayment risk of CMBS is lower than that of RMBS since CMBS is typically bound with a prepayment penalty and a defeasance clause. For amortization of the principal, RMBS is normally fully amortized upon maturity, while CMBS has a risk of a balloon payment at the end of the loan term. The market size of RMBS is much larger as the housing mortgage pool is more approachable in both Korea and the global market. In the US, CMBS issuance amount was 54 billion USD, taking up only 3% of the total mortgage related securities issuance in 2019.⁴⁰ CMBS issuance dropped sharply after 2008 and has not recovered to its previous level. The peak amount was 241 billion USD in 2007 and it dropped to 17 billion USD in 2008.

4.1.2 Features of MBS market in Korea

Of the whole MBS market, Korean RMBS market has developed referring to the model of the US Ginnie Mae, showing similar traits in mortgage loans or securitization terms with other markets. However, compared to the US CMBS market, Korea has had practically no CMBS issued until now. The inactive domestic market for commercial building development could be the primary reason for virtually no Korean CMBS market to exist. Even though the commercial real estate market has expanded substantially in Korea, still there is not a large enough commercial mortgage pool to securitize. As discussed in Chapter 2, in Korea, there has been usually more investment behavior inclined to ‘capital gain rather than income approach when investing in real estate assets. Since the fundamental structure of

⁴⁰ Sifma.org

CMBS is only valid when there is enough constant cash flow generated from commercial property, CMBS is not a suitable instrument in terms of capital gain investment tendency in Korea yet. However, with the increasing demand for domestic commercial real estate assets recently, CMBS is expected to develop as a new investment method in Korea.

Due to the absence of a sizable CMBS market in Korea, RMBS will be the main investment discussed in this chapter on the MBS category.

4.2 RMBS in Korea

4.2.1 Residential Mortgage Loan market

According to *Real Estate Finance Status and Challenges in the Korean Market*, the housing financing market in Korea can be divided into two markets. One is the primary market, which provides mortgage loan origination for housing buyers contributed by private financial institutions and the other is the ‘secondary market’ dealing with securitization of the mortgage pool that comes from the primary market. The primary market consists of two types of mortgages: private mortgages designed and delivered by private financial institutions such as banks and insurance companies, and public mortgages financed by a government organization, the Korea Housing Finance Corporation (KHFC), and sold by private institutions.⁴¹ As shown in Figure 19, the primary market has been dominated by privately financed mortgage loans. In 2018, the total amount of mortgages originating in the primary market was 630 billion USD, and 80% of the mortgages were provided by private institutions. But the size of the primary market has grown steadily in both private and public sectors due to the increased demand for housing, which makes more diversified mortgage loans available in the market.

⁴¹ Korea Development Institute. (2012). *Real Estate Finance Status and Challenges in the Korean Market*. Korea Development Institute. (p. 102)



Figure 19 - Mortgage Loan Origination Amount (in billion USD)⁴²

Mortgages in the primary market are divided into two depending on their interest rate type: Adjustable Rate Mortgage (ARM) and Fixed Rate Mortgage (FRM). Financially developed countries such as the US have a large amount of FRMs in the market, especially the public purpose mortgages with long-term maturity such as 30-year terms. A long-term maturity with fixed rate mortgage is considered easier to securitize. In comparison, the Korean mortgage market has been filled up with ARMs provided by the private sector for a long time. However, in recent years, FRMs continue to grow steadily with the active support for public housing loans structured with long-term maturity. The FRM mortgage loan issue amount increased substantially in early 2020, taking 50% of the total loan amount in the market, compared to 8% in 2010. Though it decreased to 40% again as of now in June 2020 due to recent low interest rates, it clearly shows that the Korean mortgage market has moved to a better condition for issuing MBS with the increased FRM pool in the market.

Meanwhile, another distinctive feature of mortgage loans in Korea is that the Korean market has a different perception of Loan-to-Value (LTV) in the process of loan evaluation.

⁴² Korea Housing Finance Corporation Statistics (<https://www.hf.go.kr/research/portal/stat/>)

LTV has been an important factor deciding the origination of the loan in Korea. In case of US, if LTV is under 80% it is typically considered moderate ratio for private mortgage loans. Public purpose mortgages, Federal Housing Administration (FHA) loans allow an LTV ratio of 96.5%. In Korea, LTV is highly restricted for private mortgage loans. According to the new real estate policy released in June 2020, the allowed mortgage loan LTV for housing located in government management areas is only 20% to 40% depending on the price of housing. Still, public mortgage loans typically allow higher LTV of 70%.

When the public loan is sold in the primary market and formed as a pool of mortgages, then a pool is securitized by KHFC in the secondary market. Compared to the size of the primary market, the size of secondary market is still small in Korea, because securitization of RMBS is practically led by government agency KHFC, and non-agency RMBS has been limited since the Global Financial Crisis. In 2018, of \$126 billion total public mortgage loan amount, 16% was securitized to RMBS. The percentage drops to 3% when combining public and private mortgages together as a denominator.

4.2.2 Residential Mortgage Securitization Agency

The concept of MBS started with the initiation of the Residential Mortgage-backed Securitization Act in 1999, and the first MBS was issued in 2000 by Korea Mortgage Corporation (KoMoCo). KoMoCo is a government-sponsored mortgage securitizing agency similar to Fannie Mae and Freddie Mac in the States. In 2004, KoMoCo was transferred to the Korea Housing Finance Corporation (KHFC), and thus KHFC has been responsible for public mortgage loan structuring and securities issuance since then. The newly organized KHFC was structured in reference to Fannie Mae in the US under the purpose of stabilizing the mortgage market and enhancing borrowing conditions for low-income groups with long-term, fixed-rate housing loans. KHFC finances new mortgages by securitizing and selling

MBS in the market and offers diversified opportunity to investors. Even with the difficult market conditions such as different conception of borrowers toward long-term mortgage and lack of foundation for long-term securities, KHFC succeeded in expanding FRM in the market. It is considered contributed to the housing market largely by stabilizing the primary market and developing the MBS market, which eventually led to the overall progress in the real estate finance sector in Korea.

As KHFC is a government-sponsored organization, securities issued by KHFC are public-agency RMBS that are guaranteed by the government. KHFC guarantees the principal payment of MBS, and the credit enhancement of KHFC is backed by the government. Along with credit enhancement, the government provides full investment in financing mortgages and loss compensation. Thus, expected return on RMBS has the advantage lower risk compared to other sector's bonds because MBS is regarded as a risk-free investment method equivalent to government bonds.

4.2.3 Structure of RMBS

The RMBS issued by KHFC is structured as shown in Figure 20. Since KHFC does not have a function of loan origination, private financial institutions such as banks and insurance companies provide loans collateralized by housing on behalf of KHFC and then transfer mortgage bonds to KHFC. The trust of KHFC then issues RMBS backed by a pool of mortgages that they reserve from loan originators and sell RMBS to investors in the public market. The proceeds from sales of RMBS will be eventually used to finance the new public housing loan origination. All RMBS issued are subject to be registered and reported to the Financial Services Commission (FSC) and the FSC publicly notifies investors about the MBS transaction status and details for the purpose of protecting investors.

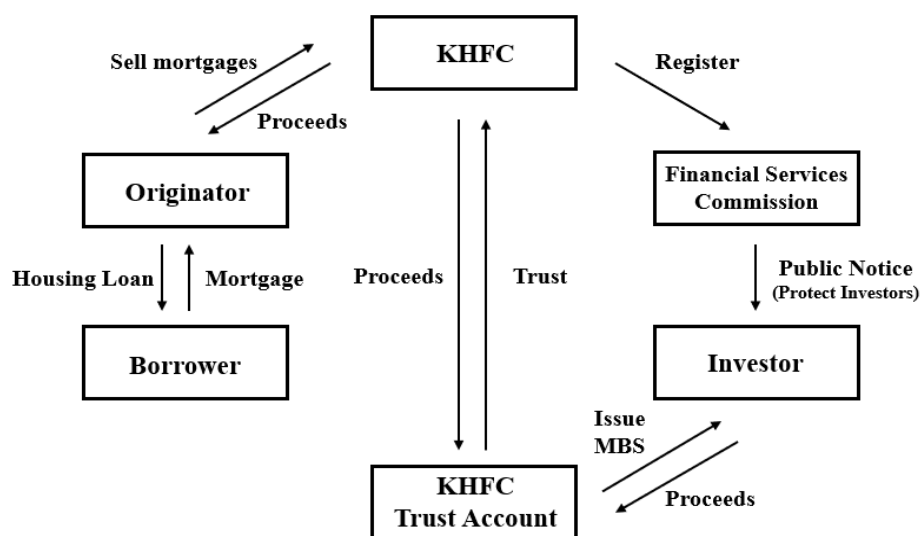

Figure 20 - Structure of Korea Housing Finance Corporation (KHFC)⁴³

Table 4 is a sample of RMBS detail issued in June 2019 with total issuance amount of \$1,168 million. With a typical structure of MBS, these securities also have a wide range of maturity and tranches backed by one pool of mortgages.

Table 4 - ‘MBS 2020-19’ detail⁴⁴

Type	Tranche	Issue Amt' (mil USD)	Maturity (year)	Coupon Rate	Coupon Payout	Credit Rating	Principal Payout
Senior	1-1	108.8	1	0.792%	Quarterly	AAA	At maturity
Senior	1-2	116.7	2	0.984%	Quarterly	AAA	At maturity
Senior	1-3	166.7	3	1.098%	Quarterly	AAA	At maturity
Senior	1-4	341.7	5	1.606%	Quarterly	AAA	At maturity
Senior	1-5	191.7	7	1.716%	Quarterly	AAA	At maturity
Senior	1-6	141.7	10	1.762%	Quarterly	AAA	At maturity
Senior	1-7	75.0	15	1.792%	Quarterly	AAA	At maturity
Senior	1-8	25.0	20	1.790%	Quarterly	AAA	At maturity
Subordinated	2-1	0.4	21	13.064%	At maturity	BB	At maturity

As shown in the table, RMBS tranches are composed of two tranches: senior tranches and subordinated tranches. Senior tranches issued by KHFC always maintain AAA credit

⁴³ Edited from Korea Housing Finance Corporation (kmbs.hf.go.kr)

⁴⁴ Korea Housing Finance Corporation (kmbs.hf.go.kr)

ratings and are guaranteed principal payment as scheduled. The maturity of each tranche ranges from 1 year to 21 years providing investment options to various investors with different types of preferences. For the subordinated tranche 2-1, the whole BB rating securities are sold to KHFC itself, so that the subordinated tranche provides support to other senior tranches. The loss is all bear by KHFC in case of default of subordinated tranche, thus this could be considered a form of guarantee.

4.3 Market Trend

The size of the RMBS market in Korea has grown substantially since the first RMBS issuance by KoMoCo in 2000. The RMBS market obviously contributed to the development of the overall Asset-Backed Securities (ABS) market in Korea.

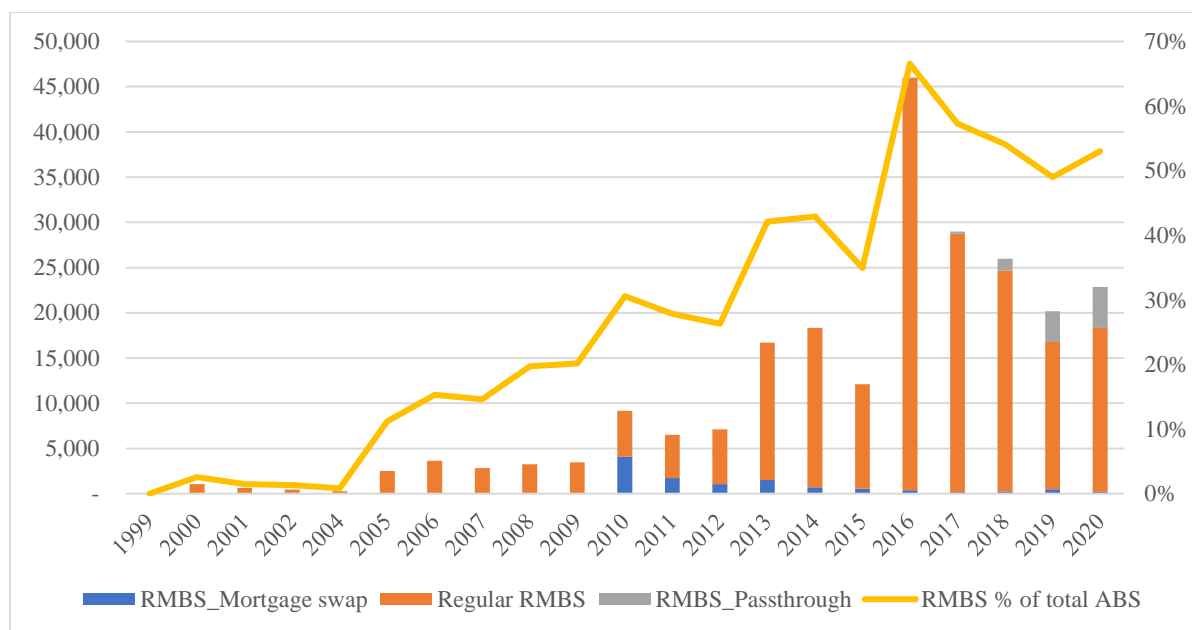

Figure 21 - MBS issuance breakdown in Korea (in million USD)⁴⁵

As shown in Figure 21, RMBS issuance peaked in 2016 with a dramatic increase of 285% compared to 2015. This shows the effort of KHFC facilitating RMBS as an investment product in the secondary market. In 2019, RMBS contributed 54% of the total ABS issuance

⁴⁵ Financial Supervisory Service (fss.or.kr), Korea Housing Finance Corporation (kmbs.hf.go.kr)

and it is expected to grow steadily with the support of government policy.

From a closer look into breakdown of RMBS, the diversification of RMBS seems further to be achieved since the product type breakdown is skewed toward the regular MBS. Currently, KHFC is issuing three types of RMBS under the name K-MBS, which are regular RMBS, Passthrough RMBS, and Mortgage-RMBS Swap. As shown in Figure 26, regular MBS dominates by making up 80% of total issuance in 2019. Though with the continuing effort of diversifying MBS, Passthrough MBS has been promoted and shown continuing growth in last four years.

Figure 22 shows that, other than securities issued by KHFC, there is currently no other issuer in the Korean market. Non-agency securities issued by private institutions such as banks, credit finance companies, and insurance companies were once activated in a small amount during the mid-2000s yet no issuance has happened at all for the last 10 years.

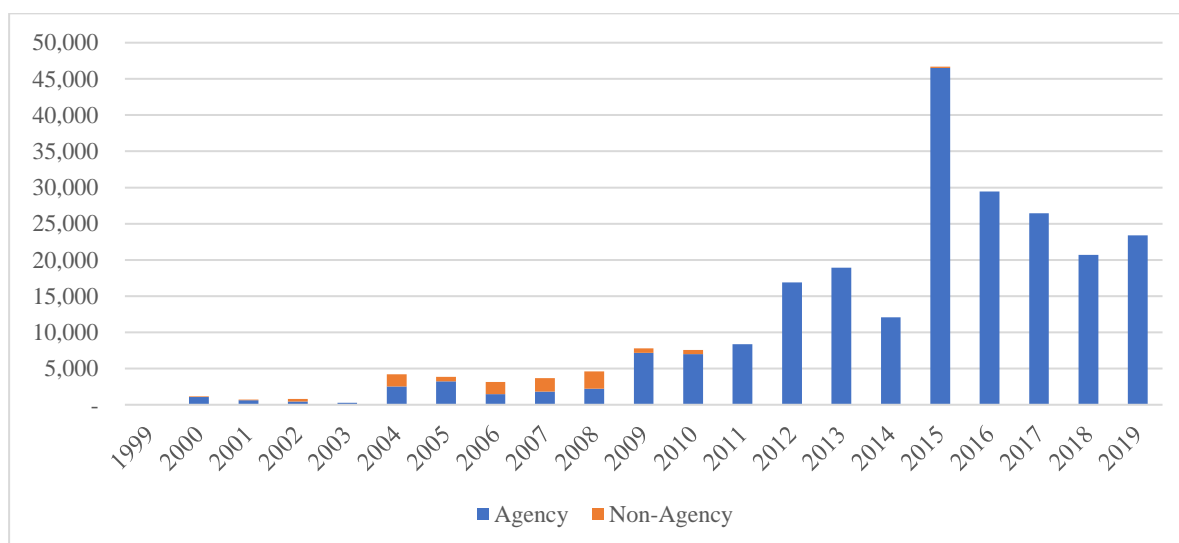

Figure 22 - Agency and Non-Agency RMBS issuance in Korea (in million USD)⁴⁶

Compared to the composition of the Korean MBS market, the US MBS market consists of relatively diversified participants. As shown in Figure 23, there was a large contribution of private sector CMBS and RMBS before 2008. Though the non-agency market contracted

⁴⁶ Financial Supervisory Service (fss.or.kr)

substantially since, it still takes part in the MBS market that \$118 billion of non-agency MBS was issued in 2019.

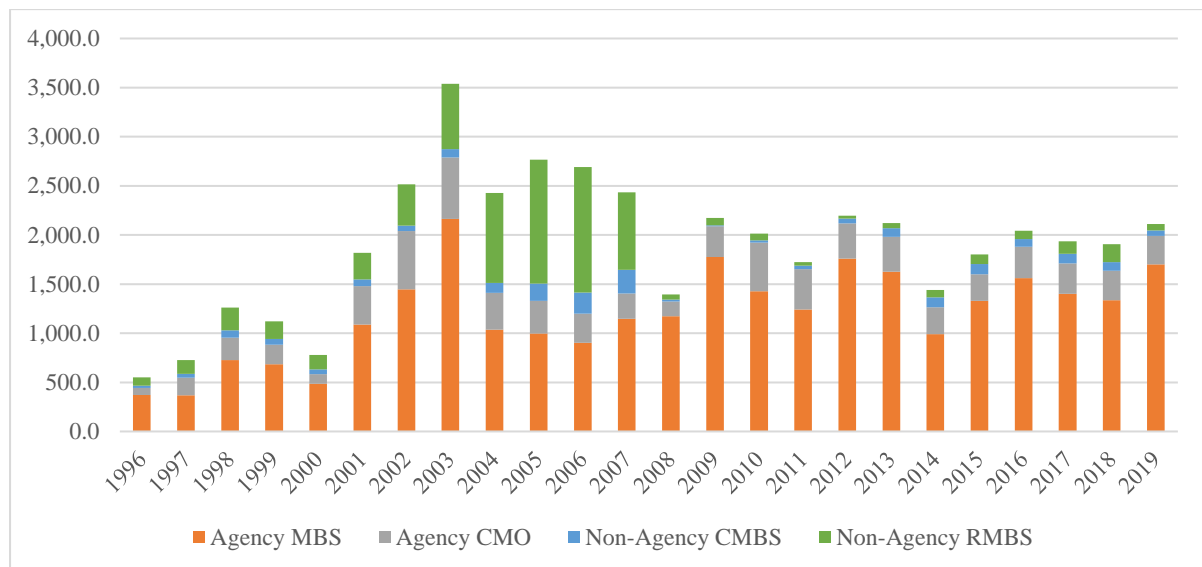

Figure 23 – MBS issuance breakdown in the US (in billion USD)⁴⁷

Referring to the US market, there has been a suggestion of utilizing non-agency RMBS in Korea as a part of the diversification effort in the RMBS market. But it seems not to be under consideration yet since non-agency RMBS is hard to control and could possibly pose a risk in the RMBS market as it triggered the Global Financial Crisis. Further risk management methods and thorough preparation are required prior to the adoption.

⁴⁷ Sifma.org

Conclusion

Real estate securitization in Korea has developed substantially for the last 20 years. It clearly brought diverse participants into the market by converting a highly illiquid asset of real estate into an easily accessible investment vehicle. The PF ABS market might not be as prosperous as it was in the mid-2000s, but it still constitutes important financing methods in the project development sector. The MBS market is certainly taking a large portion in the whole ABS market recently. MBS contributes to the public sector by stabilizing the mortgage loan market and offering diverse investment options to the public securitization market.

Yet there are some points that could be pointed out for further discussion that could eventually lead the improvement of the real estate finance sector in Korea.

1. The fundamental real estate development structure that is unique in Korea could be improved to manage risk and promote projects with certainty. Increasing developer's equity and responsibility could be one method that could resolve the skewed risk toward general contractors and investors that forms a vulnerable structure with a very low risk tolerance.

2. More in-depth project evaluation methods will be helpful for risk mitigation of investments. As real estate assets are securitized, they typically form a more complicated structure that easily clouds the intrinsic value of the asset. An objective and detailed evaluation of a subject asset would enable an accurate projection of profits and cashflow.

3. More diversified issuers and product types would lead to the next level of securitization market development. Due to many reasons, there are still few players in the Korean market. In the case of issuer diversification, there is practically no non-agency issuer as it is difficult to manage the quality and risk of non-agency real estate securities. For product types, only a Residential Mortgage-backed Securities market exists since there is not enough market demand to create a Commercial Mortgage-backed Securities market. However, the thorough market preparation for diversified issuers and product types should be preceded.

As discussed, Korea has already experienced considerable progress toward a more advanced real estate finance market until now. As the market trend shows, the role of securitization has become more important in that progress and is expected to evolve further.

BIBLIOGRAPHY

- Brueggeman, W. B., & Fisher, J. D. (2011). *Real estate finance and investments* (pp. 5-6). New York, NY: McGraw-Hill Irwin.
- Byeong Jun Cho, and Bum Jin Seo. (2013). CMBS: New Real Estate Financing Method. *Korea Investors Service Ratings Report*.
- Byun, J. H., & Chao, T. S. I. (1999). *The securitization of the real estate market in Korea: future impacts to the Korean real estate market* (Doctoral dissertation, Massachusetts Institute of Technology).
- Choudhry, M., Moskovic, D., Wong, M., Baig, S., Liu, Z., Lizzio, M., & Voicu, A. (2014). *Introduction to Securitisation and Asset-Backed Securities. Fixed Income Markets: Management, Trading, Hedging*, Second Edition, No. 261–296.
- Fender, I., & Mitchell, J. (2009). The Future of Securitisation: How to Align Incentives. *BIS Quarterly Review*.
- Geltner, D., Miller, N. G., Clayton, J., & Eichholtz, P. (2014). *Commercial real estate analysis and investments*. OnCourse Learning.
- Gorton, G., & Metrick, A. (2013). Securitization. In *Handbook of the Economics of Finance* (Vol. 2, pp. 1-70). Elsevier.
- Korea Appraisal Board Real Estate Research Center. (2019). Real Estate Market Trend Report 19-20. *Korea Appraisal Board*.
- Korea Capital Market Institute Research Center. (2020). International Real Estate Investment Trend Report. *Korea Capital Market Institute*.
- Korea Development Institute. (2012). *Real Estate Finance Status and Challenges in the Korean Market*. Korea Development Institute.
- Lee, Young Ho, Seung Dong Yoo and Kye Hong Kim. (2016). Valuation Methods for Real Estate Securitization - Focusing on the REITs and the MBS. *Korea Real Estate Research Institute*.
- Miguel Segoviano, Bradley Jones, Peter Lindner, and Johannes Blankenheim. (2013). Securitization: Lessons Learned and the Road Ahead. *International Monetary Fund*.
- Deku, S. Y., & Kara, A. (2017). *Securitization: Past, Present and Future*. Springer International Publishing.
- Patramanis, T. (2006). *Structure finance for hybrid infrastructure models: the application of project finance into public-private partnerships for the construction and operation of infrastructure* (Doctoral dissertation, Massachusetts Institute of Technology).
- Saleuddin, R. (2015). *Regulating Securitized Products: A Post Crisis Guide*, Basingstoke: Palgrave Macmillan.

Tom Schopfloch, and James M Manzi. (2020). Global Structured Finance Outlook Report 2020. *S&P Global Ratings*.

White&Case. Project bonds: Their growing role in global infrastructure finance. (2014). *White&Case LLP*.

Yescombe, E. R. (2013). *Principles of project finance*. Academic Press.

Additional Sources

Korea Financial Supervisory Service (<http://www.fss.or.kr>)

Korea Ratings (<http://www.korearatings.com/>)

Korea Housing Finance Corporation (<http://www.kmbs.hf.go.kr>)

Statistics Korea (<http://www.kostat.go.kr>)

US SIFMA (<http://www.sifma.org>)