



MIT Open Access Articles

Control for Dynamic Positioning and Way-point Tracking of Underactuated Autonomous Underwater Vehicles Using Sliding Mode Control

The MIT Faculty has made this article openly available. **Please share** how this access benefits you. Your story matters.

Citation	Elmokadem, Taha et al., "Control for Dynamic Positioning and Way-point Tracking of Underactuated Autonomous Underwater Vehicles Using Sliding Mode Control." <i>Journal of Intelligent & Robotic Systems</i> 95, 3 (September 2019): 1113–32 ©2018 Authors
As Published	https://dx.doi.org/10.1007/s10846-018-0830-8
Publisher	Springer Netherlands
Version	Author's final manuscript
Citable link	https://hdl.handle.net/1721.1/130117
Terms of Use	Creative Commons Attribution-Noncommercial-Share Alike
Detailed Terms	http://creativecommons.org/licenses/by-nc-sa/4.0/

Control for Dynamic Positioning and Way-point Tracking of Underactuated Autonomous Underwater Vehicles using Sliding Mode Control

Taha Elmokadem · Mohamed Zribi ·
Kamal Youcef-Toumi

Received: date / Accepted: date

Abstract Autonomous Underwater Vehicles (AUVs) are used in many applications such as the exploration of oceans, scientific and military missions, etc. Developing control schemes for AUVs is considered to be a very challenging task due to the complexity of the AUV model, the unmodeled dynamics, the uncertainties and the environmental disturbances. This paper develops a robust control scheme for the dynamic positioning and way-point tracking of underactuated autonomous underwater vehicles. In order to insure the robustness of the proposed controllers, the sliding mode control technique is adopted in the design process. Simulation results are given to validate the proposed controllers. Moreover, studies are presented to evaluate the robustness of the developed controllers with model uncertainties and under different types of disturbances including unknown currents.

Keywords AUV · Autonomous Underwater Vehicle · Sliding Mode Control · Dynamic Positioning · Way-point Tracking · Underactuated

1 Introduction

In recent years, the development of autonomous underwater vehicles (AUVs) has drawn a great attention. AUVs have the ability of self-propulsion underwater as well as on the water's surface. There are many applications where AUVs are needed such as exploration of oceans, sea mapping, underwater pipelines inspection, scientific and military missions, etc. In these applications, they are required to perform

We would like to thank the Kuwait Foundation for the Advancement of Science (KFAS) for the financial support of the project KFAS 2013-5505-01.

Taha Elmokadem · Mohamed Zribi (✉)
Electrical Engineering Department, Kuwait University, P.O. Box 5969, Safat 13060, Kuwait
E-mail: mohamed.zribi@ku.edu.kw

Kamal Youcef-Toumi
Department of Mechanical Engineering, Massachusetts Institute of Technology, Cambridge,
Massachusetts 02139, United States
E-mail: youcef@mit.edu

several hard tasks in an automated manner without the interaction of human operators while performing well under a variety of load conditions and with unknown sea currents. The use of AUVs can benefit social welfare in terms of saving lives, low operational costs, increased mobility, long endurances, reaching places that are difficult to reach by humans, etc. Hence, many research works were undertaken towards the development of autonomous underwater vehicles.

There are many obstacles in designing control schemes for AUVs. For example, some of the factors that make it difficult to control AUVs are the complexity of the AUV dynamics, the nonlinearities, the unmodeled dynamic effects, the system's uncertainties and the environmental disturbances. Furthermore, common AUV prototypes are underactuated where the available actuators do not produce forces and torques in all directions of motion. In other words, the vehicle has less control inputs than the number of independent generalized coordinates (i.e. degrees of freedom (DOFs)). Therefore, the problem of controlling AUVs is a very challenging task which attracted and still attracting many researchers. Hence, these challenges along with the wide applications of autonomous underwater vehicles are the main motivation for undertaking this work.

Designing control schemes for the motion of AUVs may differ according the considered control objective or strategy. Objectives of the control task of AUV include trajectory tracking, path following, dynamic positioning and way-point tracking. The trajectory tracking deals with the problem of forcing the AUV to track a time-parametrized path while the path following control problem handles the tracking of a path that is independent of time and which is expressed in terms of its geometric description [1]. The dynamic positioning problem refers to the design of control laws that forces the vehicle to reach a desired point and keeps it there. For the way-point tracking objective, it is required that the AUV tracks a sequence of way-points to reach a final goal position.

In the literature, many research works tackled the problem of controlling AUVs and marine vehicles considering different control problems such as trajectory tracking [45,30,44,28,10], path following [13,50,33,32,21], dynamic positioning and way-point tracking [3,43,46,27]. Some research works proposed combined trajectory tracking and path following control designs such as in [22].

Different nonlinear control techniques are used in these works. Some of these techniques include sliding mode control [50,12,10,11,27], higher order sliding mode [30], adaptive control [18,38,45,37,9,17,35,3], learning control [54], Neural network control [40,48,53,25], fuzzy control [31,49], Lyapanov-based techniques [34,41] and Lyapanov's direct method [29].

Several attempts have been made to address the dynamic positioning problem for AUVs. Some of the published studies have not considered the robustness of their designs neglecting the effects of environmental disturbances and model uncertainties such as [14,16,2,19,36]. Recent research has focused on robust solutions to be more suitable for practical conditions. In [3], a nonlinear adaptive controller was used to achieve the dynamic positioning and way-point tracking of AUVs taking into consideration unknown ocean current and model uncertainties. This approach relies on estimated values of ocean currents speed and direction obtained through an observer which adds more computational complexity. Moreover, it considers only model perturbations due to parameters uncertainties neglecting other sources of disturbances within the dynamic model. The research [39] considered a robust approach based on hybrid control taking into account perturbations due to

ocean currents only leaving out model uncertainties as future research. Similarly, [20] proposed a backstepping controller for the dynamic positioning considering only the case of irrotational constant ocean currents. Furthermore, their controller works only if a certain condition relating the AUV's heading and the currents direction is satisfied which is limiting in practice. Another robust dynamic positioning control was proposed in [26] using model predictive control and neural networks which has an expensive computational cost. Moreover, it considers a fully actuated case of AUVs. The shortcomings of the available approaches in the literature to address the dynamic positioning of underactuated AUVs under disturbances motivate more research in this field.

The focus of the present work is to develop control schemes for the dynamic positioning and way-point tracking problems considering the lateral motion of AUVs (i.e. the motion in the horizontal plane). Since AUVs often operate in harsh underwater environments, the proposed control schemes are designed to be robust against unmodeled dynamics, model uncertainties and external disturbances due to ocean currents and waves. Also, the considered system is underactuated since it is the most common type of AUVs. It is known that an underactuated system cannot be stabilized by any continuous time-invariant feedback controller [52]; this implies that discontinuous control laws are needed to solve the problem of controlling underactuated AUVs. Therefore, the sliding mode control technique is adopted for the controllers design proposed in this work; this technique is known for its robustness that provides superior tracking performance even when bounded disturbances are acting on the AUV or with parameters or model uncertainties. To sum up, the main contribution of this work is the development of a robust dynamic positioning and way-point tracking controllers for underactuated AUVs that can perform well under environmental disturbances and modeling uncertainties.

This paper is organized in the following manner. Section 2 presents a model of the AUV for the lateral motion and formulates the control problem considered in this work. Also, a coordinate transformation is given to facilitate the control design. The proposed solution to the considered control problem is then conducted in two stages. The first stage handles the dynamic positioning of the vehicle at the neighborhood of a given target position; the designed robust controller to achieve this task is given in section 3. In the second stage, a robust control scheme is proposed to steer the vehicle through a sequence of given way points to reach a desired final position; this controller is presented in section 4. Simulation results are provided to validate the performance of the proposed controllers. Moreover, the robustness of the proposed controllers is investigated in the subsections 3.3 and 4.3 using computer simulations. Finally, section 5 summarizes the conclusions of this work.

2 AUV Model and Problem Formulation

This section presents the model of an underactuated AUV for the lateral motion; it also formulates the problem under consideration, and provides a coordinate transformation.

2.1 Dynamic Model of the AUV

Modeling the motion of AUVs requires studying the geometrical aspects of the motion as well as analyzing the forces and torques causing the motion. These two parts are referred to as kinematics and kinetics of the AUV respectively [24].

The AUVs motion can be represented by a set of independent displacements and rotations that describes the vehicle's position and orientation. They are described using 6 degrees of freedom (DOF) which are known as the surge (the longitudinal motion), the sway (the lateral motion), the heave (the vertical motion), the roll (the rotational motion about the longitudinal axis), the pitch (the rotational motion about the lateral axis) and the yaw (the rotation about the vertical axis). Modeling an AUV considering all the degrees of freedom results in a very complicated model that poses a lot of problems for the design of controllers. Therefore, one of the common approaches is to separate this model into models for the lateral and the vertical motions in order to facilitate the control design. The work done in this paper considers the three degree of freedom lateral motion model of AUVs (i.e. the motion in the horizontal plane) which corresponds to the surge, the sway and the yaw DOFs.

Additionally, special reference frames are required to present the model of the AUV which are the *Earth-fixed* $\{n\}$ and the *body-fixed* $\{b\}$ reference frames (see Fig. 1). The definitions of these reference frames according to [23] are:

- The **Earth-fixed** frame $\{n\} = (x_n, y_n, z_n)$ is called the North-East-Down frame (NED), and it is considered to be inertial. The vehicle's coordinates in this frame are described relative to a fixed origin o_n defined in the center of this frame.
- The **body-fixed** frame (BODY) $\{b\} = (x_b, y_b, z_b)$ is a moving frame fixed to the vehicle. Its origin o_b is defined at the center of the vehicle. The axes of this frame are usually chosen to coincide with the principal axes of inertia.

The considered model in this work for the lateral motion of AUVs is derived from [23] assuming the following: (i) the vehicle is neutrally buoyant ($W = B$), (ii) the quadratic damping terms are neglected, (iii) the sway motion is unactuated, (iv) the center of gravity $x_g = 0$ and (v) there are external disturbances and model uncertainties.

Let u and v be the surge and the sway linear velocities of the vehicle respectively, and let r be the vehicle's yaw angular velocity. Also, let x and y be the coordinates of the vehicle's center of mass, and ψ be its orientation. Note that, the linear and angular velocities (i.e. (u, v, r)) are described in the body-fixed frame $\{b\}$, and the vehicle's position coordinates and orientation (i.e. (x, y, ψ)) are described in the earth-fixed frame $\{n\}$.

- The kinematics model of the AUV can be written such as,

$$\begin{aligned}\dot{x} &= u \cos \psi - v \sin \psi \\ \dot{y} &= u \sin \psi + v \cos \psi \\ \dot{\psi} &= r.\end{aligned}\tag{1}$$

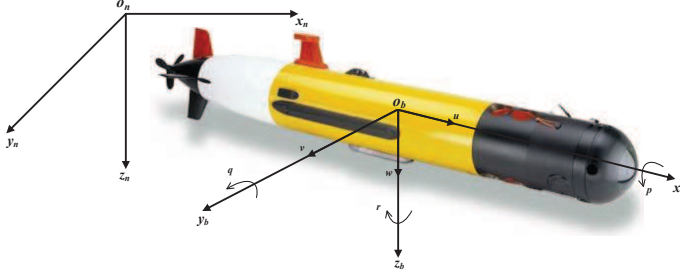

Fig. 1 The earth-fixed and body-fixed reference frames for an AUV

- The dynamics model of the AUV can be written such as,

$$\begin{aligned}\dot{u} &= M_1(X_u u + a_1 v r + \tau_u) + d_1 \\ \dot{v} &= M_2(Y_v v + a_2 u r) + d_2 \\ \dot{r} &= M_3(N_r r + a_3 u v + \tau_r) + d_3.\end{aligned}\quad (2)$$

In the above model, the parameters M_1 , M_2 and M_3 are such that:

$$\begin{aligned}M_1 &= \frac{1}{m - X_{\dot{u}}} \\ M_2 &= \frac{1}{m - Y_{\dot{v}}} \\ M_3 &= \frac{1}{I_z - N_{\dot{r}}},\end{aligned}$$

and the parameters a_1 , a_2 and a_3 are defined by:

$$\begin{aligned}a_1 &= (m - Y_{\dot{v}}) \\ a_2 &= (X_{\dot{u}} - m) \\ a_3 &= (Y_{\dot{v}} - X_{\dot{u}}),\end{aligned}$$

Note that, the following standard notation is used: m is vehicle's mass, I_z is the vehicle's moment of inertia about the z -axis, X_u , Y_v and N_r are the linear damping terms, and $X_{\dot{u}}$, $Y_{\dot{v}}$ and $N_{\dot{r}}$ are the hydrodynamic added mass terms in the surge, the sway and the yaw directions of motion respectively. The terms $d_1(t)$, $d_2(t)$ and $d_3(t)$ represent the model uncertainties and external disturbances acting on the AUV such as ocean currents. It is assumed that the disturbances $d_1(t)$, $d_2(t)$ and $d_3(t)$ are bounded such that $|d_i(t)| \leq D_i$ where $D_i \geq 0$ for $(i = 1, 2, 3)$.

The available control inputs are the surge force τ_u and the yaw torque τ_r generated by the AUV's actuators, and no actuation is available in the sway direction. Therefore, the problem being considered corresponds to an underactuated control problem.

2.2 Problem Formulation

This paper addresses two control problems for the motion of AUVs; these problems are the dynamic positioning and way-point tracking. For the dynamic positioning

control problem, it is required to force the AUV to reach the neighborhood of a final, desired position starting from any initial position. The way-point tracking problem requires the AUV to reach a final, desired position starting from any initial position by following a specified path between these two positions; this path is defined by a sequence of way-points. Therefore, the tackled control problems considered in this work can be formulated as follows:

The Dynamic Positioning Control Problem:

For the nonlinear model of an underactuated AUV described by (1) and (2), a robust control law that computes the required surge force τ_u and yaw torque τ_r needs to be designed in order to force the vehicle's position $p_0 = (x, y)$ to reach a neighborhood $B_\epsilon(p)$ centered around a desired point $p = (x_d, y_d)$ with a radius of $\epsilon > 0$ such that $B_\epsilon(p) := \{p \in R^2, \|p_0 - p\| < \epsilon\}$.

The Way-point Tracking Control Problem [3]:

Consider the nonlinear model of an underactuated AUV described by (1) and (2). For $i = 1, 2, \dots, n$, let $P = \{p_1, p_2, \dots, p_n\}$ such that $p_i = (x_i, y_i) \in R^2$ be a sequence of way-points described in the earth-fixed frame $\{n\}$. Each point p_i is associated with a neighborhood $B_{\epsilon_i}(p_i)$ centered around p_i with a radius of $\epsilon_i > 0$ such that $B_{\epsilon_i}(p_i) := \{p \in R^2, \|p - p_i\| < \epsilon_i\}$.

It is required to design a robust control law that computes the required surge force τ_u and yaw torque τ_r in order to force the vehicle's position (x, y) to reach the neighborhood of p_n after passing through a given sequence of neighborhoods $B_{\epsilon_i}(p_i)$; $i = 1, 2, \dots, (n - 1)$.

Therefore, the following sections are devoted to the design of control schemes to solve both the dynamic positioning and way-point tracking control problems. The developed controllers assumes that the measured/estimated values of the system states are available from the vehicle's navigation system; examples of available navigation systems algorithms to estimate AUVs motion can be found in [5–7, 15].

2.3 Coordinate Transformation

A coordinate transformation is now presented which will be used to facilitate the control design. Let x_d and y_d be the coordinates of a generic way-point, and let the vector from the origin of the body-fixed frame $\{b\}$ to the point (x_d, y_d) be denoted by V_w (see Fig. 2). The length of the vector V_w is denoted as e ; the angle of V_w measured from the x-axis of the body-fixed frame (i.e. x_b) is denoted by β . Motivated by the work in [4, 3], we consider the following coordinate transformation:

$$\begin{aligned} e &:= \sqrt{(x - x_d)^2 + (y - y_d)^2} \\ x - x_d &:= -e \cos(\psi + \beta) \\ y - y_d &:= -e \sin(\psi + \beta) \\ \psi + \beta &:= \tan^{-1} \left(\frac{(y - y_d)}{(x - x_d)} \right) \end{aligned} \tag{3}$$

It should be noted that the angle β needs to be selected carefully (i.e., one has to select the angle $\psi + \beta$ in the proper quadrant). Also, note that $e > 0$ according to

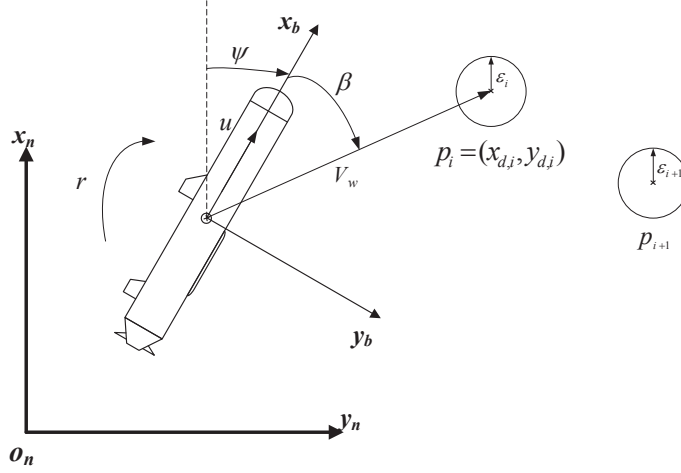

Fig. 2 Illustration of the coordinate transformation for the dynamic positioning and way-point tracking control problems

this transformation. The coordinate transformation expressed by (3) is illustrated in Fig. 2.

Moreover, since $\ddot{\beta}$ is needed in the control design, it is obtained by differentiating $\dot{\beta}$ with respect to time as follows,

$$\begin{aligned}
 \ddot{\beta} &= \frac{1}{e^2} \left((\dot{u} \sin(\beta) + u \dot{\beta} \cos(\beta))e - u \sin(\beta) \dot{e} \right) \\
 &\quad - \frac{1}{e^2} \left((\dot{v} \cos(\beta) - v \dot{\beta} \sin(\beta))e - v \cos(\beta) \dot{e} \right) - \dot{r} \\
 &= \frac{1}{e^2} \left(e \dot{\beta} (u \cos(\beta) + v \sin(\beta)) - \dot{e} (u \sin(\beta) - v \cos(\beta)) \right) \\
 &\quad + \frac{\sin(\beta)}{e^2} \left(M_1 (X_u u + a_1 v r + \tau_u) + d_1 \right) \\
 &\quad - \frac{\cos(\beta)}{e^2} \left(M_2 (Y_v v + a_2 u r) + d_2 \right) - M_3 (N_r r + a_3 u v + \tau_r) - d_3 \quad (4)
 \end{aligned}$$

Remark 1 It should be mentioned that the coordinate transformation given by (3) is not valid when $e = 0$. This will not be an issue for the control design since the objective of the control problem is to force the AUV to reach the neighborhood of the desired point (i.e. force $|e| \leq \epsilon$ where ϵ is an arbitrary small positive constant).

Using the coordinate transformation given by (3), the AUV's kinematic model can be expressed as follows:

$$\begin{aligned}
 \dot{e} &= -u \cos(\beta) - v \sin(\beta) \\
 \dot{\beta} &= \frac{u}{e} \sin(\beta) - \frac{v}{e} \cos(\beta) - r \\
 \dot{\psi} &= r.
 \end{aligned} \quad (5)$$

Moreover, $\ddot{\beta}$ can be written such that,

$$\ddot{\beta} = \bar{f} + \bar{g}\tau_r + \frac{\sin(\beta)}{e^2}d_1 - \frac{\cos(\beta)}{e^2}d_2 - d_3 \quad (6)$$

where \bar{f} and \bar{g} are defined such as,

$$\begin{aligned} \bar{f} = & \frac{1}{e^2} \left(e\dot{\beta}(u \cos(\beta) + v \sin(\beta)) - \dot{e}(u \sin(\beta) - v \cos(\beta)) \right) + \frac{M_1 \sin(\beta)}{e^2} (X_u u + a_1 vr) \\ & - \frac{M_2 \cos(\beta)}{e^2} (Y_v v + a_2 ur) - M_3 (N_r r + a_3 uv) \end{aligned} \quad (7)$$

$$\bar{g} = -M_3 \quad (8)$$

3 Dynamic Positioning Control

3.1 Design of the Dynamic Positioning Controller

This section presents a dynamic positioning control scheme for AUVs; this control scheme aims to force any AUV to reach a desired position. The design is carried out using the coordinate transformation in (3). Since this transformation is not defined when $e = 0$, the following lemma, which addresses this case, is given first before proposing the developed control scheme. Note that the case $e = 0$ can occur in some rare situations when sudden disturbances act on the AUV resulting in moving the vehicle to the desired position directly or when the AUV starts at the desired position which is a trivial case.

Lemma 1 *For the case when $e = 0$, the asymptotic convergence of u and r to zero is guaranteed if the surge force and yaw torque are chosen such that,*

$$\tau_u = -X_u u - a_1 vr - \frac{K_1}{M_1} \text{sign}(u) \quad (9)$$

$$\tau_r = -N_r r - a_3 uv - \frac{K_2}{M_3} \text{sign}(r) \quad (10)$$

where $K_1 > D_1 > 0$ and $K_2 > D_3 > 0$. Furthermore, the asymptotic convergence of the sway velocity v to zero is ensured if $d_2 = 0$.

Proof Consider the following Lyapanov function candidate,

$$\bar{V} = \frac{1}{2}u^2 + \frac{1}{2}r^2. \quad (11)$$

The time derivative of \bar{V} along the dynamics in (2) is such that,

$$\begin{aligned} \dot{\bar{V}} = & u\dot{u} + r\dot{r} \\ = & u(M_1 X_u u + M_1 a_1 vr + M_1 \tau_u + d_1) + r(M_3 N_r r + M_3 a_3 uv + M_3 \tau_r + d_3) \\ \leq & u(M_1 X_u u + M_1 a_1 vr + M_1 \tau_u) + D_1 |u| + r(M_3 N_r r + M_3 a_3 uv + M_3 \tau_r) + D_3 |r| \end{aligned}$$

Substituting (9) and (10) in (12) gives the following,

$$\begin{aligned} \dot{\bar{V}} \leq & -K_1 u \text{sign}(u) + D_1 |u| + K_2 r \text{sign}(r) + D_3 |r| \\ = & -(K_1 - D_1) |u| - (K_2 - D_3) |r| \end{aligned} \quad (12)$$

Since $K_1 > D_1 > 0$ and $K_2 > D_3 > 0$, it is clear that $\dot{\hat{V}} < 0$. This clearly proves the asymptotic convergence of both u and r to zero.

Moreover, if $d_2 = 0$ then the sway dynamics when $u = r = 0$ will be such that,

$$\dot{v} = M_2 Y_v v \quad (13)$$

Since $M_2 > 0$ and $Y_v < 0$, the asymptotic convergence of v to zero is guaranteed.

Therefore, the asymptotic convergence of (u, v, r) to $(0, 0, 0)$ is guaranteed for the case when $e = 0$ under the assumption that $d_2 = 0$ and using τ_u and τ_r given in (9) and (10).

It should be mentioned that if $d_2 \neq 0$ and $|d_2| \leq D_2$, then it can be shown that v is uniformly ultimately bounded.

The developed dynamic positioning control scheme is presented next.

In order to force the vehicle to reach the neighborhood of the desired point, we define the following error,

$$\tilde{e} = e - \epsilon \quad (14)$$

where ϵ is a small positive constant that defines the neighborhood of the desired point.

We propose to use a sliding mode control scheme to force the AUV to reach the neighborhood of a desired position. To that matter, it is required to force \tilde{e} and β to converge to zero. Therefore, we will choose the sliding surfaces S_1 and S_2 in terms of \tilde{e} and β such that,

$$S_1 = u - c_1 \tanh(k\tilde{e}) \quad (15)$$

$$S_2 = \dot{\beta} + c_2 \beta \quad (16)$$

where c_1 , c_2 and k are positive constants. Also, let the design parameters W_1 , W_2 , K_1 and K_2 be positive constants such that $K_1 > D_1 > 0$ and $K_2 > D_3 > 0$.

Theorem 1 Consider the nonlinear model of the AUV's kinematic and dynamic equations of motion given by (1) and (2) respectively. Let the control law for the surge force and yaw torque be such that:

$$\tau_u = \begin{cases} -X_u u - a_1 v r + \frac{1}{M_1} \left(c_1 k \dot{\tilde{e}} \operatorname{sech}^2(k\tilde{e}) - D_1 \operatorname{sign}(S_1) \right) \\ + \frac{1}{M_1} \left(-W_1 \operatorname{sign}(S_1) \right), & \text{if } e \neq 0 \\ -X_u u - a_1 v r - \frac{K_1}{M_1} \operatorname{sign}(u), & \text{if } e = 0 \end{cases} \quad (17)$$

$$\tau_r = \begin{cases} \frac{1}{\bar{g}} \left(-\bar{f} - c_2 \dot{\beta} - \left(\frac{D_1}{e^2} + \frac{D_2}{e^2} + D_3 \right) \operatorname{sign}(S_2) - W_2 \operatorname{sign}(S_2) \right), & \text{if } e \neq 0 \\ -N_{rr} r - a_3 u v - \frac{K_2}{M_3} \operatorname{sign}(r), & \text{if } e = 0 \end{cases} \quad (18)$$

where \bar{f} and \bar{g} are defined in (7) and (8), ϵ is an arbitrary small positive constant, $c_1, c_2, k > 0$ and D_1, D_2 and D_3 are bounds on the disturbances d_1, d_2 and d_3 .

If the proposed controllers in (17) and (18) are applied to the AUV, then the asymptotic convergence of the position of the vehicle (x, y) to the neighborhood of the desired position (x_d, y_d) is guaranteed.

Proof The proof starts with the case when $e \neq 0$. Consider the following Lyapunov function candidate:

$$V_1 = \frac{1}{2}S_1^2 + \frac{1}{2}S_2^2 \quad (19)$$

The time derivative of V_1 can be obtained using (2), (6) and (14) as follows:

$$\begin{aligned} \dot{V}_1 &= S_1\dot{S}_1 + S_2\dot{S}_2 \\ &= S_1(\dot{u} - c_1k\dot{\tilde{e}}\operatorname{sech}^2(k\tilde{e})) + S_2(\ddot{\beta} + c_2\dot{\beta}) \\ &= S_1\left(M_1(X_uu + a_1vr + \tau_u) + d_1 - c_1k\dot{\tilde{e}}\operatorname{sech}^2(k\tilde{e})\right) \\ &\quad + S_2\left(\bar{f} + \bar{g}\tau_r + \frac{\sin(\beta)}{e^2}d_1 - \frac{\cos(\beta)}{e^2}d_2 - d_3 + c_2\dot{\beta}\right) \\ &\leq S_1\left(M_1(X_uu + a_1vr + \tau_u) - c_1k\dot{\tilde{e}}\operatorname{sech}^2(k\tilde{e})\right) + D_1|S_1| \\ &\quad + S_2\left(\bar{f} + \bar{g}\tau_r + c_2\dot{\beta}\right) + |S_2|\left(\frac{D_1}{e^2} + \frac{D_2}{e^2} + D_3\right) \end{aligned} \quad (20)$$

Substituting in (20) for the control laws in (17) and (18) gives,

$$\begin{aligned} \dot{V}_1 &\leq -W_1S_1\operatorname{sign}(S_1) - W_2S_2\operatorname{sign}(S_2) \\ &= -W_1|S_1| - W_2|S_2| \end{aligned} \quad (21)$$

It is clear that $\dot{V}_1 < 0$ for $(S_1, S_2) \neq (0, 0)$ since the design parameters W_1 and W_2 are positive scalars. Therefore, the finite-time convergence of the sliding surfaces S_1 and S_2 to zero is guaranteed using the proposed control laws.

Furthermore, once the trajectories reach the sliding surfaces (i.e. $S_1 = S_2 = 0$), Eqs. (15) and (16) imply the following,

$$u = c_1\tanh(k\tilde{e}) \quad (22)$$

$$\dot{\beta} = -c_2\beta \quad (23)$$

On the sliding surfaces $S_1 = S_2 = 0$ and using the first equation of system (5), the following dynamics are ensured:

$$\dot{\tilde{e}} = -c_1\tanh(k\tilde{e})\cos(\beta) - v\sin(\beta) \quad (24)$$

$$\dot{\beta} = -c_2\beta \quad (25)$$

Since $c_2 > 0$, Eq. (25) guarantees that β asymptotically converges to zero as t tends to infinity. Thereafter, the Eq. (24) reduces when β converges to zero to the following,

$$\dot{\tilde{e}} = -c_1\tanh(k\tilde{e}). \quad (26)$$

The solution of Eq. (26) is as follows:

$$\tilde{e}(t) = \frac{1}{k} \log \left[\frac{1}{2} e^{-c_1kt} \left(e^{k\tilde{e}(0)} - e^{-k\tilde{e}(0)} \right) + \frac{1}{2} \left(e^{-2k(\tilde{e}(0)+c_1t)} (e^{2k\tilde{e}(0)} - 1)^2 + 4 \right)^{1/2} \right]. \quad (27)$$

This result indicates the asymptotic convergence of \tilde{e} to zero as t tends to infinity since the design parameters c_1 and k are positive constants.

Therefore, the proposed control scheme ensures that (β, \tilde{e}) asymptotically converges to $(0, 0)$. That is, one can guarantee that the vehicle's position asymptotically converges to the neighborhood of the desired point under the application of the proposed controller.

Equations (14), (22), (24) and (25) lead to the asymptotic convergence of $(e, \dot{e}, \beta, \dot{\beta}, u)$ to $(\epsilon, 0, 0, 0, 0)$. Hence, the asymptotic convergence of r to $-\frac{v}{\epsilon}$ can be inferred from Eq. (5). Therefore, from equation (2), the sway dynamics can be written such that:

$$\dot{v} = -\gamma_1 v + d_2 \quad (28)$$

where $\gamma_1 = -M_2 Y_v$. Notice that $\gamma_1 > 0$ since $M_2 > 0$ and $Y_v < 0$.

In the following, we will show that the sway velocity v is bounded if $|d_2| \leq D_2$. To that effect, consider the following Lyapanov candidate function,

$$V_3 = \frac{1}{2}v^2 + \frac{1}{2}v^4 \quad (29)$$

The function V_3 satisfies the following:

$$\alpha_1(v) \leq V_3 \leq \alpha_2(v) \quad (30)$$

where $\alpha_1(v)$ and $\alpha_2(v)$ are class κ_∞ functions defined such that:

$$\alpha_1(v) = \frac{1}{2}v^2, \quad \alpha_2(v) = \frac{1}{2}v^2 + \frac{1}{2}v^4 \quad (31)$$

The time derivative of V_3 along the dynamics in (28) gives,

$$\begin{aligned} \dot{V}_3 &= v\dot{v} + v^3\dot{v} = (v + v^3)(-\gamma_1 v + d_2) \\ &= -\gamma_1 v^2 - \gamma_1 v^4 + d_2 v + d_2 v^3 \\ &\leq -\gamma_1 v^2 - \gamma_1 v^4 + D_2 |v| + D_2 |v|^3 \\ &= -\gamma_1 v^2 - \gamma_1 v^4 + \theta(|v|^2 + |v|^4) - \theta(|v|^2 + |v|^4) + D_2(|v| + |v|^3), \quad 0 < \theta < \gamma_1 \\ &= -(\gamma_1 - \theta)v^2 - (\gamma_1 - \theta)v^4 - \theta|v|(|v| + |v|^3) + D_2(|v| + |v|^3) \\ &\leq -(\gamma_1 - \theta)v^2 - (\gamma_1 - \theta)v^4 \quad \forall |v| \geq \frac{D_2}{\theta} = \mu \end{aligned} \quad (32)$$

The result obtained in (32) proves that the sway velocity v is uniformly ultimately bounded with an ultimate bound of:

$$b = \alpha_1^{-1}(\alpha_2(\mu)) = \sqrt{\mu^2 + \mu^4}. \quad (33)$$

Remark 2 It should be mentioned that if $d_2 = 0$, the proposed controller will guarantee the asymptotic convergence of (u, v, r) to $(0, 0, 0)$ as can be seen from (28) since $\gamma_1 > 0$.

Moreover, if $e = 0$ and $d_2 = 0$, the proposed controller ensures the asymptotic convergence of (u, v, r) to $(0, 0, 0)$ according to lemma 1. On the other hand, if $e = 0$ and $d_2 \neq 0$, the sway dynamics will be such that,

$$\dot{v} = -\gamma_1 v + d_2. \quad (34)$$

The solution of the above equation is given by,

$$v(t) = e^{-\gamma_1 t} v_0 + e^{-\gamma_1 t} \int_0^t e^{\gamma_1 \tau} d_2(\tau) d\tau \quad (35)$$

where $v_0 = v(0)$ is the initial value of v . This equation indicates that after a small time t the sway velocity v will be different than zero which will force either $\dot{x} \neq 0$, or $\dot{y} \neq 0$ or both. As a consequence, the vehicle will move from its position resulting in either $x \neq x_d$, or $y \neq y_d$ or both; this means that the case changes to $e \neq 0$. Once $e \neq 0$, the proposed controller will force the vehicle to reach $e = \epsilon$ as proven earlier.

Thus, the proposed control scheme in (17) and (18) guarantee the asymptotic convergence of $(\tilde{e}, \beta, u, v, r)$ to $(0, 0, 0, 0, 0)$ if $d_2 = 0$. Moreover, the controller ensures the asymptotic convergence of (\tilde{e}, β, u, r) to $(0, 0, 0, -\frac{v}{\epsilon})$ while the sway velocity v remains bounded if $d_2 \neq 0$. That is, the proposed controller forces the AUV to reach the neighborhood of the desired position (x_d, y_d) and keeping it there.

Remark 3 The proposed design of S_1 in (15) gives us the freedom to choose the desired surge velocity in order to reach a goal point and avoid practical limitations on the velocity by properly choosing the design parameter c_1 . This is due to the fact that on the surface S_1 , the surge velocity is $u = c_1 \tanh(k\tilde{e})$ which implies that u tends to c_1 if the vehicle is far away from the goal destination.

Remark 4 The proposed control law can be calculated online due to its low computational complexity (i.e. it can be computed directly from the measured/estimated values of position, orientation and velocities). This is considered as a favorable feature for practical implementation since some AUVs may have limited onboard computational power.

Remark 5 A common concern in the practical implementation of the proposed control scheme in (17) and (18) is its switching behavior which is known as the chattering problem due to the signum function. In practice, such function is approximated using a saturation function to reduce the chattering effects as will be shown in the simulation section. A number of unmanned underwater vehicles implementing sliding mode controllers have shown good performance in practice such as the Benthos RPV-430, the Hamburg ROV and the Subjugator vehicles (see [51] and references therein).

3.2 Simulation Results

The proposed control laws for the surge force τ_u and the yaw torque τ_r given in (17) and (18) are applied to the nonlinear system described by the AUV's model in (1) and (2), and the performance is evaluated using computer simulations. In these simulations, a practical AUV called the REMUS AUV is considered. The REMUS AUV was developed by Von Alt and associates [47]; this AUV has many features which include compact size and weight, proven reliability (used by the U.S. Navy), ease of operation and a full suit of standard sensors. These features

make the REMUS AUV a good choice in many scientific and military applications such as hydro-graphic surveys, mine counter measure operations, harbor security operations, environmental monitoring, etc. Therefore, we consider the REMUS 100 AUV for simulations in this paper. Its parameters are given in table 1. In this sub-section, the model is considered with no disturbances (i.e. $d_1 = d_2 = d_3 = 0$).

In order to avoid the well known chattering problem, the discontinuous sign function used in the control laws (17) and (18) is replaced by the popular boundary layer concept. Generally, the boundary layer is defined by replacing the $sign(S)$ in the control laws by a saturating function $sat(S)$ defined as follows:

$$sat(S) = \begin{cases} -1, & S < -\varphi \\ S/\varphi, & -\varphi \leq S \leq \varphi \\ 1, & S > \varphi \end{cases} \quad (36)$$

where φ is a positive constant that normally describes the error associated with the smooth approximation of the signum function by the saturation function; the boundary layer thickness is defined as 2φ .

The simulation starts with the following initial condition: $x(0) = y(0) = \psi(0) = u(0) = v(0) = r(0) = 0$, and the desired position is chosen such that $(x_d, y_d) = (8, 10)$ with $\epsilon = 0.5$ m. The desired radius of the targeted neighborhood ϵ is chosen taking into consideration the length of the REMUS 100 AUV ($L = 1.6$ m). Also, the design parameters are selected such that: $k = 1$, $c_1 = 0.5$, $c_2 = 1$, $W_1 = 1$, $W_2 = 1.5$ and $\varphi = 0.001$.

The simulation results are illustrated in figures 3, 4, 5 and 6. Figure 3 depicts the path taken by the vehicle (i.e the y position versus the x position of the AUV). It can be clearly seen from this figure that the vehicle's position (x, y) converges to the neighborhood of the desired position $(x_d, y_d) = (8, 10)$; note that the neighborhood of the desired position is represented by a circle. In Fig. 4, the AUV velocities u , v and r versus time are shown. One can see from this figure that the surge velocity is $u = 0.5$ m/s as long as the vehicle is far away from the goal destination which is for $t < 20$ s; this agrees with what we discussed in remark 3. Then, the surge velocity starts to decrease near the final destination in order to completely stop in the neighborhood of the destination. Also, this figure shows that the velocities converge to zero once the vehicle reaches the neighborhood of the desired point. The simulated surge force and sway torque are shown in Fig. 5. Discontinuities in both controllers can be observed at about 0.5 seconds. This occurs because both sliding surfaces S_1 and S_2 are very close to zero and changing their signs. Figure 6 shows the transformed coordinates e and β versus time; it is clear that the proposed control scheme forces the transformed coordinates (e, β) to converge to $(\epsilon, 0) = (0.5$ m, 0) with β converging to zero faster than e in order to align the vehicle with the error vector between its position and the final destination.

Therefore, it can be concluded that the proposed sliding mode controller solves the dynamic positioning control problem of an AUV moving in the horizontal plane.

Table 1 The REMUS 100 AUV model parameters [42]

Parameter	Value	Units
m	30.48	kg
L	1.6	m
I_z	3.45	$kg \cdot m^2$
X_u	-8.8065	kg/s
Y_v	-65.5457	kg/s
N_r	-6.7352	kg/s
$X_{\dot{u}}$	-0.93	kg
$Y_{\dot{v}}$	-35.5	kg
$N_{\dot{r}}$	-35.5	$kg \cdot m^2$

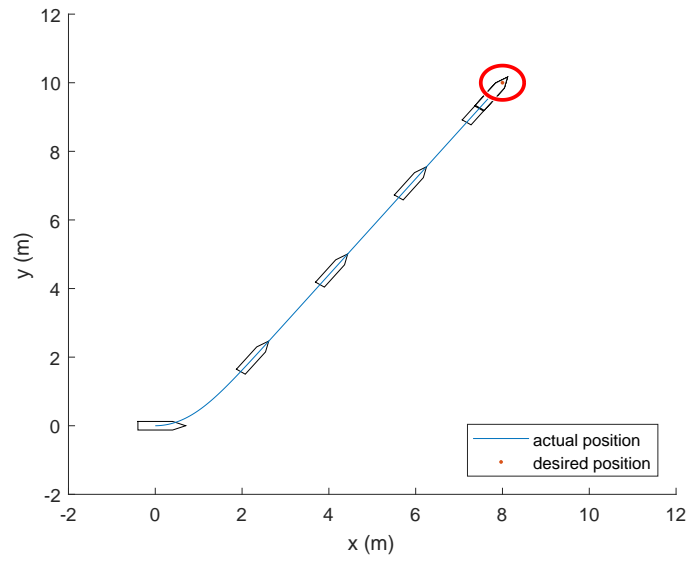
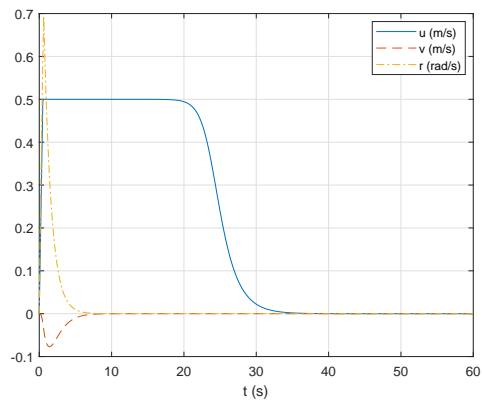
**Fig. 3** The path of the AUV**Fig. 4** The velocities of the AUV versus time

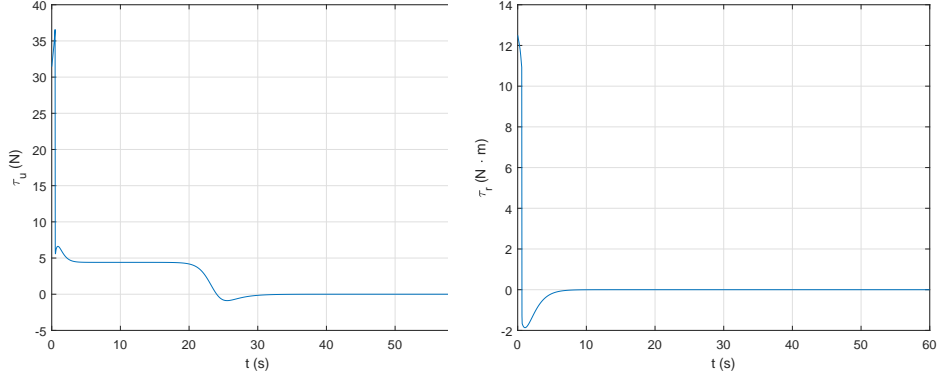

Fig. 5 The surge and yaw control laws of the AUV versus time

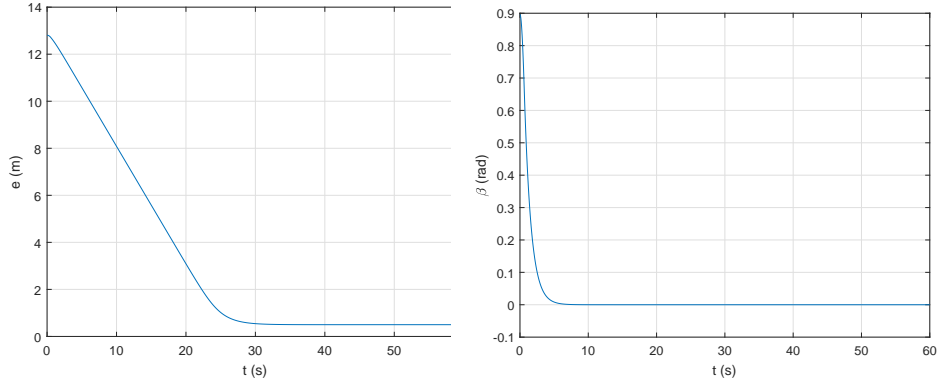

Fig. 6 The transformed coordinates e and β of the AUV versus time

3.3 Robustness Studies

The proposed dynamic positioning control scheme is tested for robustness by performing several computer simulations; the obtained results are presented in this subsection.

In these simulations, three cases of the disturbances d_1 , d_2 and d_3 are taken into considerations in addition to a case including model with uncertainties. To include uncertainties within the mode, its parameters were varied randomly around their nominal values given in table 1 within $\pm 20\%$ while the controller uses only the nominal values. The three cases of disturbances are as follows:

1. Disturbances due to ocean current effects (case 1) (see remark 6):

$$d_1(t) = 0.05 \cos \psi + 0.05 \sin \psi, d_2(t) = -0.05 \sin \psi + 0.05 \cos \psi, d_3(t) = 0 \quad (37)$$

2. Sinusoidal Disturbances (case 2):

$$d_1(t) = d_2(t) = 0.1 \cos(t), d_3(t) = 0.1 \sin(t) \quad (38)$$

3. Disturbances for a time period (case 3):

$$d_1(t) = d_2(t) = d_3(t) = 0.15[u_s(t-10) - u_s(t-15)] \quad (39)$$

where $u_s(t)$ is the unit step function which is defined as follows:

$$u_s(t) = \begin{cases} 1, & t \geq 0 \\ 0, & \text{otherwise.} \end{cases}$$

The results of the simulations for the three cases of disturbances are given in figures 7-12, and the results for the case of model uncertainties are shown in figures 13-14. The actual path of the AUV is shown in figures 7, 9, 11 and 13, and the surge and the yaw controllers versus time are presented in figures 8, 10, 12 and 14. For the three cases, the given results show how the controllers change their values at steady state in order to suppress the effect of the disturbances. Also, note that for the first two cases, the vehicle moves to the neighborhood of the targeted position but it will not stop moving since $d_2(t) \neq 0$ for $t > 0$. However, this is not the case for the third case where $d_2 \neq 0$ for a period of time and $d_2 = 0$ otherwise. For that case, the vehicle stops completely in the neighborhood of the final destination and the velocities u , v and r converge to zero. The simulation results agree with what was mentioned in remark 2. Thus, the obtained results clearly show that the vehicle reaches the goal position regardless of the bounded disturbances acting on the AUV. Furthermore, it is clear from the results of the last case that the controller works well with model uncertainties. Therefore, we can conclude that the developed dynamic positioning control scheme is robust against bounded disturbances and model uncertainties.

Remark 6 [8] The ocean currents effect can be modeled by considering it as a constant disturbance in the earth-fixed frame which is further projected onto the body-fixed frame. In this approach, it is assumed that the current is constant and irrotational in the earth-fixed frame. Therefore, one can define the vector of current disturbance in the earth fixed frame as $\nu_C = [\nu_{Cx}, \nu_{Cy}, 0] \in \mathbb{R}^3$ and its corresponding disturbance vector in the body-fixed frame can be obtained from the following:

$$\mathbf{d}_C = \mathbf{R}(\psi)\nu_C \quad (40)$$

where the transformation matrix $\mathbf{R}(\psi)$ is a 3×3 matrix and it is such that:

$$\mathbf{R}(\psi) = \begin{bmatrix} \cos \psi & \sin \psi & 0 \\ -\sin \psi & \cos \psi & 0 \\ 0 & 0 & 1 \end{bmatrix}. \quad (41)$$

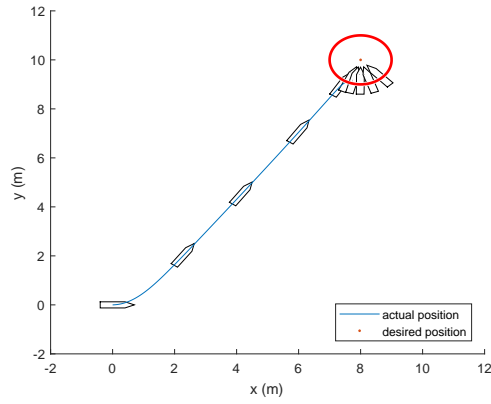

Fig. 7 The actual path of the AUV using the dynamic positioning controller with the disturbances of case 1

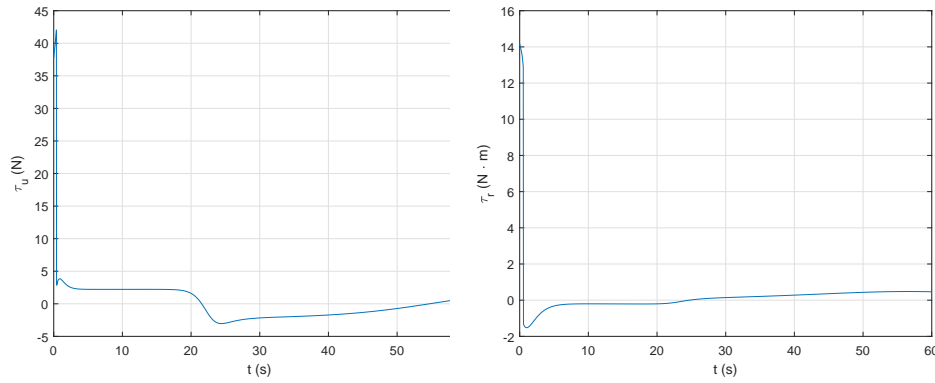

Fig. 8 The surge and yaw control laws versus time using the dynamic positioning controller with the disturbances of case 1

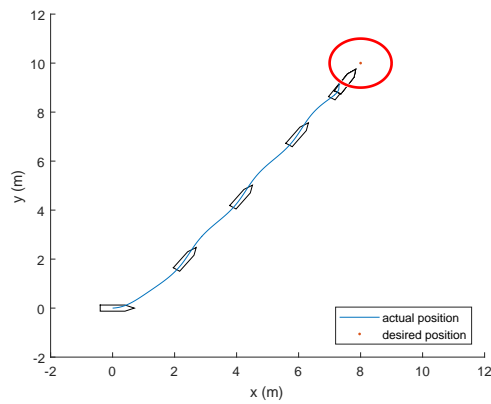

Fig. 9 The actual path of the AUV using the dynamic positioning controller with the disturbances of case 2

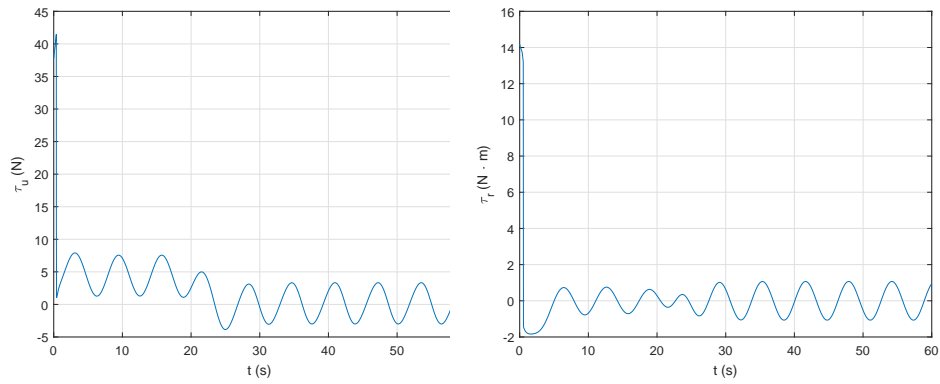

Fig. 10 The surge and yaw control laws versus time using the dynamic positioning controller with the disturbances of case 2

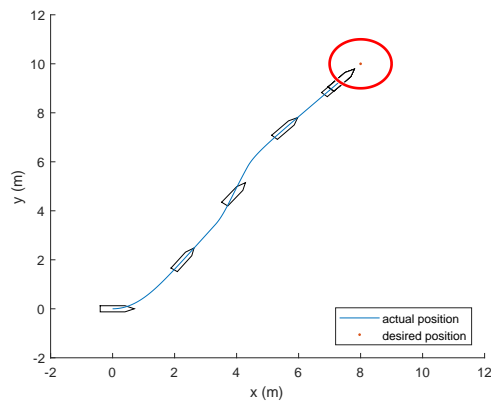

Fig. 11 The actual path of the AUV using the dynamic positioning controller with the disturbances of case 3

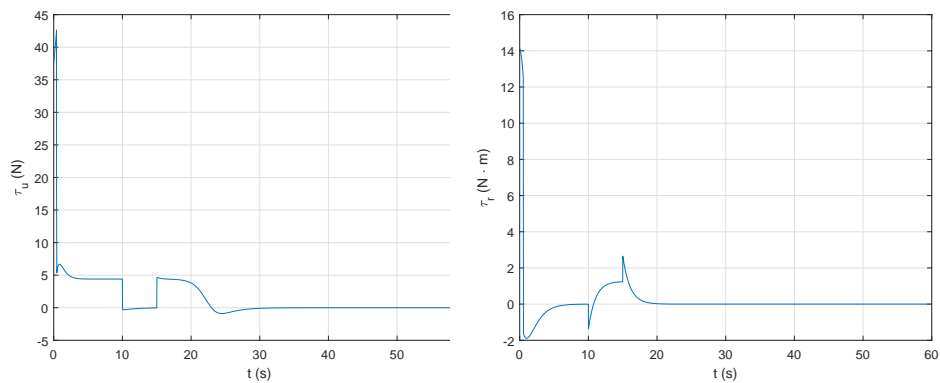

Fig. 12 The surge and yaw control laws versus time using the dynamic positioning controller with the disturbances of case 3

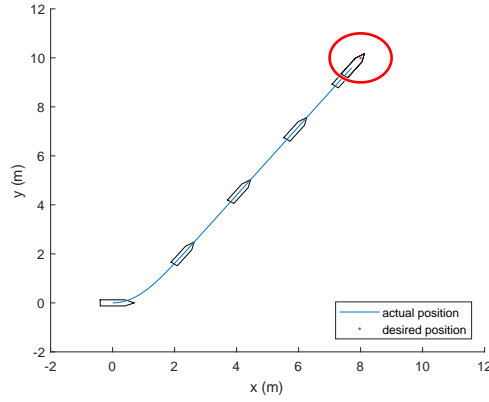

Fig. 13 The actual path of the AUV using the dynamic positioning controller considering a model with uncertainties

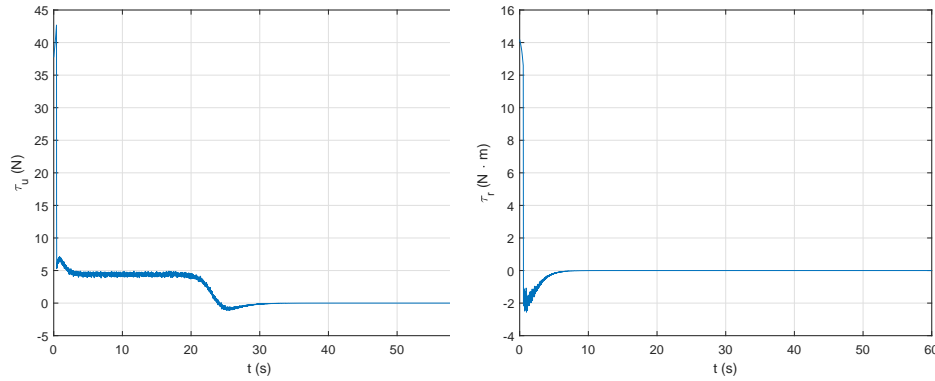

Fig. 14 The surge and yaw control laws versus time using the dynamic positioning controller considering a model with uncertainties

4 Way-point Tracking Algorithm

Motivated by the work done in [3], a control algorithm is presented in this section in order to force the underactuated AUV to pass through a sequence of neighborhoods $B_{\epsilon_i}(p_i) := \{p = (x, y) \in \mathbb{R}^2 : \|p - p_i\| \leq \epsilon_i\}$ with a center p_i and a radius $\epsilon_i > 0$ where $i = 1, 2, \dots, (n - 1)$. Finally, the AUV is required to be positioned in the neighborhood of a final target position $p_n = (x_n, y_n)$.

4.1 Control Algorithm

Define the following transition function:

$$\sigma = \eta((x, y), i) \quad (42)$$

where $\eta((x, y), i)$ is such that:

$$\eta((x, y), i) = \begin{cases} i, & \|p - p_i\|_2 > \epsilon_i \\ i + 1, & \|p - p_i\|_2 \leq \epsilon_i; i \neq n \\ n, & i = n \end{cases} \quad (43)$$

and ϵ_i is an arbitrary small positive constant representing the radius of a ball centered around p_i (neighborhood of p_i). Using this definition, the desired way-points are then computed according to:

$$(x_{d,i}, y_{d,i}) = p_\sigma \quad (44)$$

where σ refers to the index of the current way-point to be reached.

Consider the following sliding surfaces:

$$\bar{S}_1 = u - u_d \quad (45)$$

$$\bar{S}_2 = \dot{\beta} + c\beta \quad (46)$$

where $c > 0$ and u_d is the desired surge velocity such that $u_d > 0$ and $\dot{u}_d = 0$.

Let $\bar{W}_1 > 0$, $\bar{W}_2 > 0$, and let the surge force τ_u and the yaw torque τ_r be such that:

$$\tau_u = -X_u u - a_1 v r + \frac{1}{M_1} (-D_1 \text{sign}(\bar{S}_1) - \bar{W}_1 \text{sign}(\bar{S}_1)) \quad (47)$$

$$\tau_r = \frac{1}{\bar{g}} \left(-\bar{f} - c\dot{\beta} - \left(\frac{D_1}{e^2} + \frac{D_2}{e^2} + D_3 \right) \text{sign}(\bar{S}_2) - \bar{W}_2 \text{sign}(\bar{S}_2) \right) \quad (48)$$

where \bar{f} and \bar{g} are as defined in (7) and (8).

Theorem 2 Consider the nonlinear model of an AUV moving in the horizontal plane and let e and β be defined as in (3) with $(x_d, y_d) = (x_{d,i}, y_{d,i})$ computed according to (42)-(44). The control law for the surge force τ_u and yaw torque τ_r given by (47) and (48) guarantee that the AUV passes through the sequence of way points $p = \{p_1, p_2, \dots, p_{n-1}\}$ with the associated neighborhoods $\{B_{\epsilon_1}(p_1), B_{\epsilon_2}(p_2), \dots, B_{\epsilon_{n-1}}(p_{n-1})\}$ where ϵ_i is an arbitrary small positive constant.

Furthermore, at the final point p_n , if the control law proposed in (17) and (18) is applied, then the vehicle's position (x, y) will converge to the neighborhood of p_n .

Proof Consider the following Lyapanov function candidate:

$$V_4 = \frac{1}{2} \bar{S}_1^2 + \frac{1}{2} \bar{S}_2^2 \quad (49)$$

Differentiating V_4 with respect to time and substituting for the surge and yaw control laws using (47) and (48) yields,

$$\begin{aligned}
\dot{V}_4 &= \bar{S}_1 \dot{\bar{S}}_1 + \bar{S}_2 \dot{\bar{S}}_2 \\
&= \bar{S}_1(\dot{u} - \dot{u}_d) + \bar{S}_2(\ddot{\beta} + c\dot{\beta}) \\
&= \bar{S}_1 \left(M_1(X_u u + a_1 v r + \tau_u) + d_1 \right) + \bar{S}_2 \left(f_2 + g_2 \tau_r + \frac{\sin(\beta)}{e^2} d_1 - \frac{\cos(\beta)}{e^2} d_2 - d_3 + \dot{\beta} \right) \\
&\leq \bar{S}_1 \left(M_1(X_u u + a_1 v r + \tau_u) \right) + |\bar{S}_1| D_1 + \bar{S}_2 \left(f_2 + g_2 \tau_r + \dot{\beta} \right) + |\bar{S}_2| \left(\frac{D_1}{e^2} + \frac{D_2}{e^2} + D_3 \right) \\
&\leq -\bar{W}_1 \bar{S}_1 \text{sign}(\bar{S}_1) - \bar{W}_2 \bar{S}_2 \text{sign}(\bar{S}_2) \\
&= -\bar{W}_1 |S_1| - \bar{W}_2 |S_2| \tag{50}
\end{aligned}$$

Since \bar{W}_1 and \bar{W}_2 are positive scalars, it is obvious that $\dot{V}_4 < 0$ for $(\bar{S}_1, \bar{S}_2) \neq (0, 0)$. This implies that the finite-time convergence of both surfaces \bar{S}_1 and \bar{S}_2 to zero is guaranteed when the proposed controllers are applied.

One can see from (45) and (46) that when both surfaces converge to zero, the convergence of $(\beta, \dot{\beta}, u)$ to $(0, 0, u_d)$ is guaranteed. Furthermore, since the controllers in (47) and (48) are applied for $e \geq \epsilon_i > 0$, eq. (5) implies the following,

$$r = -\frac{v}{e}. \tag{51}$$

Now, we can use this result in order to show that v will remain bounded which will indicate the same for r . In order to do so, the sway dynamics is found to be:

$$\begin{aligned}
\dot{v} &= M_2(Y_v v + a_2 u_d r) + d_2 \\
&\leq M_2(Y_v v - a_2 u_d \frac{v}{e}) + D_2 \\
&\leq -\gamma_2 v + D_2
\end{aligned}$$

where $\gamma_2 = -M_2(Y_v + \frac{a_2 u_d}{e}) > 0$ since $M_2, u_d, e > 0$ and $Y_v, a_2 < 0$. This ensures that v is uniformly ultimately bounded which can be proven using the same Lyapanov function V_3 in (29).

Hence, the control law in (47) and (48) guarantees the convergence of the vehicle's position to the neighborhood of a desired point $p_i = (x_d, y_d)$. Moreover, if (x_{d_i}, y_{d_i}) are computed according to (42)-(44) for a sequence of way points, the control law will steer the vehicle through the neighborhoods of each point p_i (for $i = 1, 2, \dots, (n-1)$). This is then followed by positioning the vehicle at the neighborhood of p_n through the application of the control law in (17) and (18) which was proven in theorem 1.

4.2 Simulation Results

The efficiency of the proposed way-point tracking control algorithm is tested by applying it to the REMUS AUV and simulating the vehicle's performance. The design parameters are selected as follows: $u_d = 0.5$, $c = 0.5$, $\bar{W}_1 = 1$, $\bar{W}_2 = 0.25$,

$\varphi = 0.01$, $\epsilon_i = 1$ m and $\epsilon_n = 0.5$ m. The sequence of points to be tracked are taken to be $\{(3,0), (6,0), (9,0), (12,4), (12,8), (12,12), (15,16), (18,16), (21,16)\}$. The initial condition for the simulation is taken to be $x(0) = y(0) = \psi(0) = u(0) = v(0) = r(0) = 0$. This subsection considers the model under no disturbances (i.e. $d_1 = d_2 = d_3 = 0$).

Figures 15, 16, 17 and 18 present the simulation results. In Fig. 15, the AUV velocities versus time are presented. The surge velocity converges to the desired value $u_d = 0.5$ m/s as it passes through the way-points. Then, it starts to decrease near the final point p_n in about 60 seconds in order to settle down in the neighborhood of p_n . Once there, the surge, sway and yaw velocities converge to zero and the vehicle stops. The surge and sway control laws are shown in Fig. 16. It is obvious from Fig. 17 that the vehicle passes through the neighborhood of the desired way-points until it settles at the neighborhood of the final destination.

Also, the transformed coordinates e and β versus time are presented in Fig. 18. This figure clearly shows that $e = 3$ and $\beta = 0$ at the start of the simulation which corresponds to the first point of the sequence. Then, the proposed controllers force the vehicle to move towards that point resulting in the decrease of the position error e until it reaches $e = \epsilon_1 = 1$ m at about 4 seconds meaning that the vehicle is in the neighborhood of the first point. Once there, the next point in the sequence is selected according to the proposed algorithm in (42)-(44), and hence the error to that point is determined to be $e = 4$ m which will be fed to the controller so that the required surge force and yaw torque are computed in order to force the vehicle to move towards the second point and so on for each point in the sequence. This procedure will be repeated till the last point is selected where the dynamic positioning scheme starts to take effect in order to stop the vehicle at the neighborhood of the final point where $e = \epsilon_9 = 0.5$ m as can be seen for $t > 70$ s. Discontinuities can be seen in both the surge and yaw controllers at about 58 seconds; these discontinuities occur once the dynamic positioning control scheme is applied when the final point is selected.

Regarding the angle β , it can be observed from the plot that starting from the 3rd point in the sequence the required point to be reached is at a different angle than the vehicle's heading angle where for each point the controller managed to bring the vehicle's heading to the new desired point successfully by forcing β to converge to zero. This can be seen from the yaw torque plot where discontinuities occurs at different times since \bar{S}_2 changes its value accordingly with the value of β in order to force the vehicle to be aligned with the targeted point in the sequence to maintain the tracking (i.e. a discontinuity occurs every time the vehicle needs to realign itself for the new destination). Therefore, it can be concluded that the proposed control algorithm works well for the way-point tracking of the AUV.

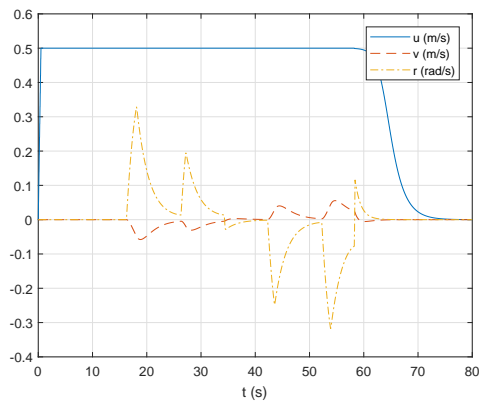

Fig. 15 The velocities of the AUV versus time

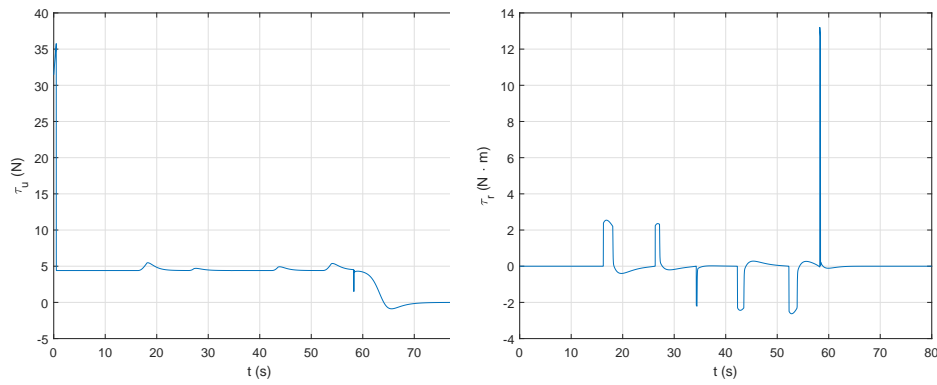

Fig. 16 The surge and yaw control laws of the AUV versus time

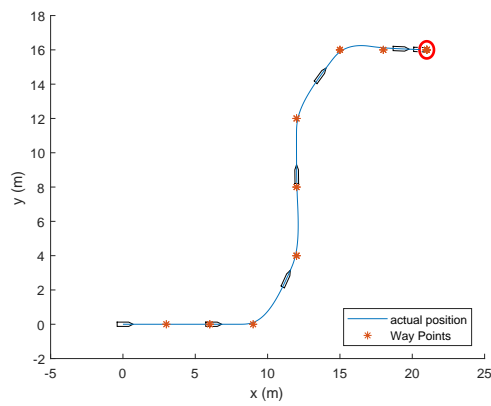

Fig. 17 The path of the AUV

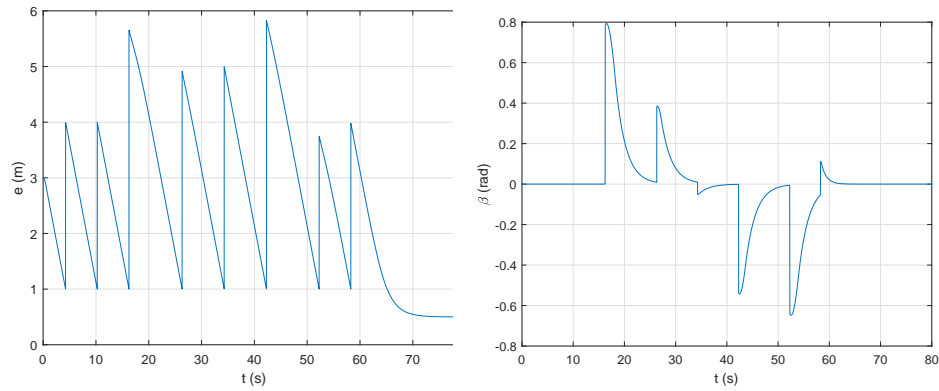

Fig. 18 The transformed coordinates e and β of the AUV versus time

4.3 Robustness Studies

The robustness of the developed way-point tracking control scheme for AUVs is investigated in this subsection. Several computer simulations were carried out considering the three cases of the disturbances given in (37)-(39) and the case of model uncertainties. The obtained simulations results are presented in figures 19-26. Figures 19, 21, 23 and 25 show the actual path of the AUV, and figures 20, 22, 24 and 26 show the surge and the yaw controllers versus time. As mentioned before, discontinuities can be seen in the controllers whenever the vehicle is not aligned with the error vector meaning that $\beta \neq 0$ which leads to a change in the sign of the surface \bar{S}_2 . It is clear from these results that the way-point tracking objective is achieved using the proposed control scheme for all the cases. Thus, we conclude that the proposed control scheme for the way-point tracking of AUVs is robust under bounded disturbances and model uncertainties.

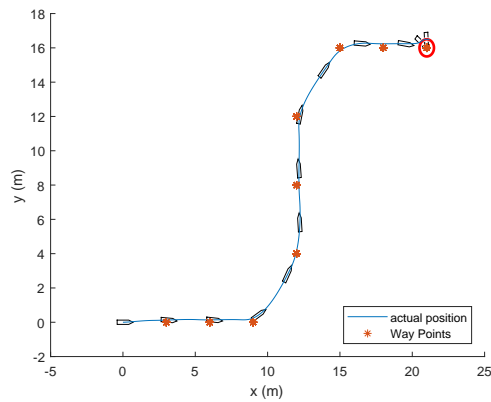

Fig. 19 The actual path of the AUV with the disturbances of case 1

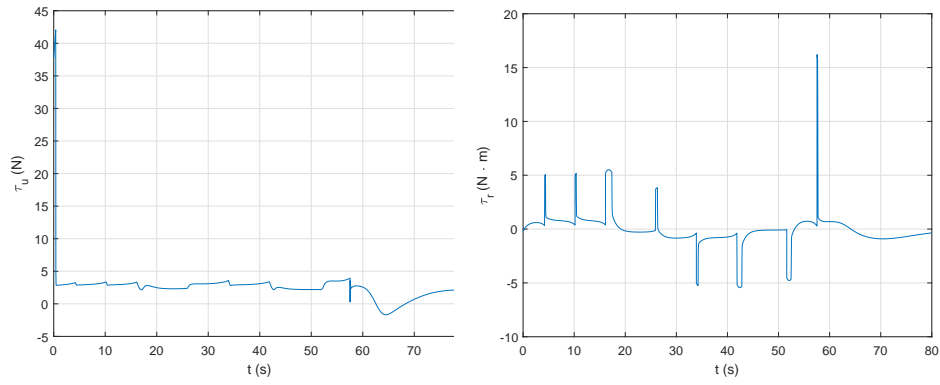

Fig. 20 The surge and yaw control laws versus time with the disturbances of case 1

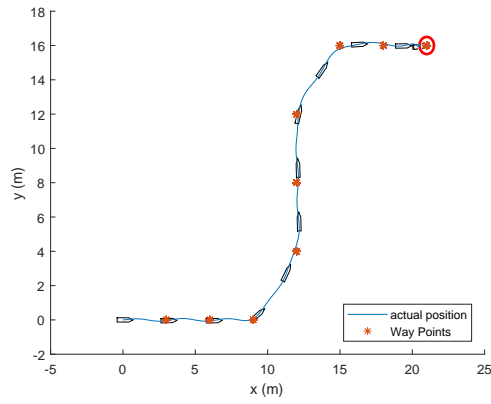

Fig. 21 The actual path of the AUV with the disturbances of case 2

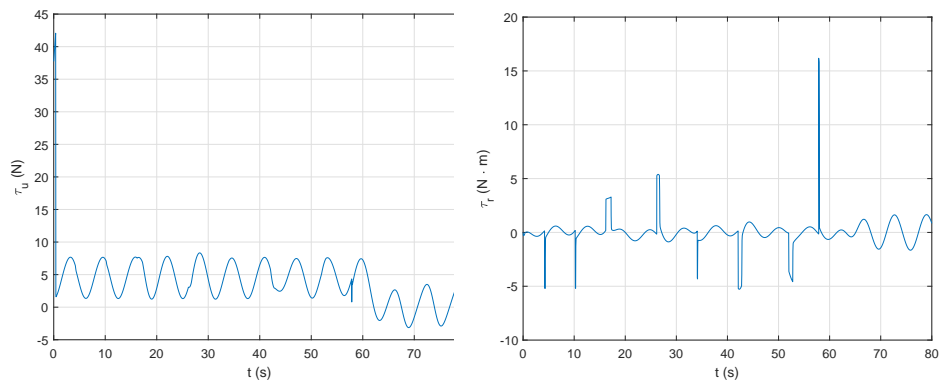

Fig. 22 The surge and yaw control laws versus time with the disturbances of case 2

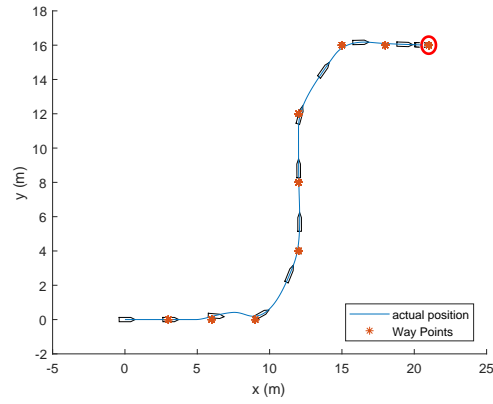

Fig. 23 The actual path of the AUV with the disturbances of case 3

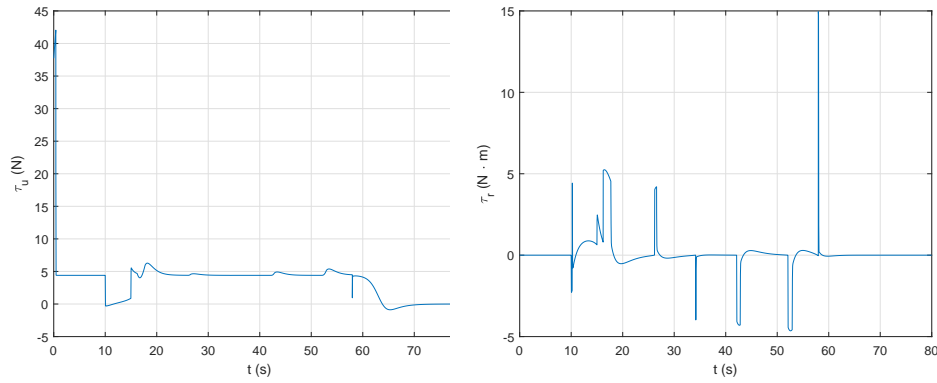

Fig. 24 The surge and yaw control laws versus time with the disturbances of case 3

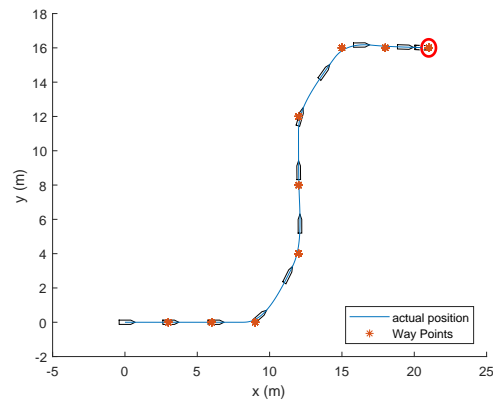

Fig. 25 The actual path of the AUV considering a model with uncertainties

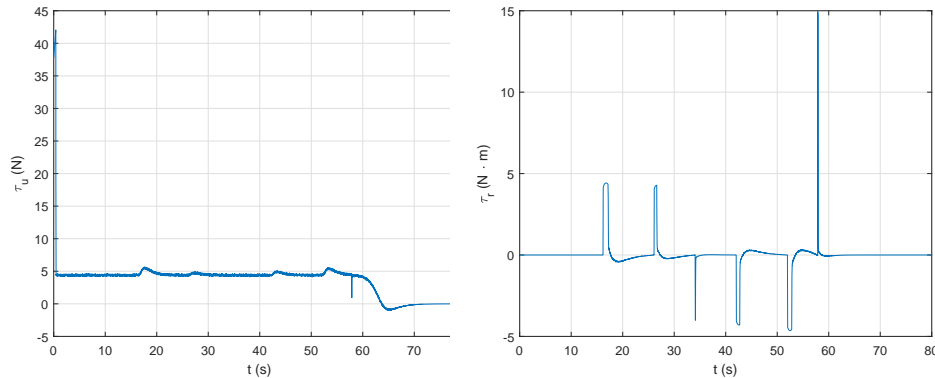

Fig. 26 The surge and yaw control laws versus time considering a model with uncertainties

5 Conclusion

A robust dynamic positioning and way-point tracking control scheme for AUVs is presented in this work. This control scheme aims to steer the vehicle through a sequence of way points to reach a target position where it settles in its neighborhood. The proposed controller is based on the sliding mode control technique. Simulations are performed on the REMUS AUV to validate the proposed controller. The simulation results indicate that the proposed control scheme works well. Moreover, simulation studies are presented to show the robustness of the proposed control scheme.

References

1. Aguiar, A.P., Hespanha, J.P.: Position tracking of underactuated vehicles. In: Proceedings of the IEEE 2003 American Control Conference, vol. 3, pp. 1988–1993 (2003)
2. Aguiar, A.P., Pascoal, A.M.: Global stabilization of an underactuated autonomous underwater vehicle via logic-based switching. In: Decision and Control, 2002, Proceedings of the 41st IEEE Conference on, vol. 3, pp. 3267–3272. IEEE (2002)
3. Aguiar, A.P., Pascoal, A.M.: Dynamic positioning and way-point tracking of underactuated AUVs in the presence of ocean currents. *International Journal of Control* **80**(7), 1092–1108 (2007)
4. Aicardi, M., Casalino, G., Bicchi, A., Balestrino, A.: Closed loop steering of unicycle like vehicles via lyapunov techniques. *IEEE Robotics & Automation Magazine* **2**, 27–35 (1995)
5. Allotta, B., Bartolini, F., Caiti, A., Costanzi, R., Di Corato, F., Fenucci, D., Gelli, J., Guerini, P., Monni, N., Munafò, A., et al.: Typhoon at commsnet13: Experimental experience on auv navigation and localization. *Annual Reviews in Control* **40**, 157–171 (2015)
6. Allotta, B., Caiti, A., Chisci, L., Costanzi, R., Di Corato, F., Fantacci, C., Fenucci, D., Meli, E., Ridolfi, A.: An unscented kalman filter based navigation algorithm for autonomous underwater vehicles. *Mechatronics* **39**, 185–195 (2016)
7. Allotta, B., Caiti, A., Costanzi, R., Fanelli, F., Fenucci, D., Meli, E., Ridolfi, A.: A new auv navigation system exploiting unscented kalman filter. *Ocean Engineering* **113**, 121–132 (2016)
8. Antonelli, G.: *Underwater Robots*. Springer (2014)
9. Antonelli, G., Caccavale, F., Chiaverini, S., Fusco, G.: A novel adaptive control law for underwater vehicles. *IEEE Transactions on Control Systems Technology* **11**(2), 221–232 (2003)
10. Ashrafioun, H., Muske, K.R., McNinch, L.C., Soltan, R.A.: Sliding-mode tracking control of surface vessels. *IEEE Transactions on Industrial Electronics* **55**(11), 4004–4012 (2008)

11. Bessa, W.M., Dutra, M.S., Kreuzer, E.: Depth control of remotely operated underwater vehicles using an adaptive fuzzy sliding mode controller. *Robotics and Autonomous Systems* **56**(8), 670–677 (2008)
12. Bessa, W.M., Dutra, M.S., Kreuzer, E.: An adaptive fuzzy sliding mode controller for remotely operated underwater vehicles. *Robotics and Autonomous Systems* **58**(1), 16–26 (2010)
13. Caharija, W., Pettersen, K.Y., Gravdahl, J.T., Børhaug, E.: Path following of underactuated autonomous underwater vehicles in the presence of ocean currents. In: CDC, pp. 528–535 (2012)
14. Chang, W.J., Chen, G.J., Yeh, Y.L.: Fuzzy control of dynamic positioning systems for ships. *Journal of Marine Science and Technology* **10**(1), 47–53 (2002)
15. Costanzi, R., Fenucci, D., Giagnoni, S., Munafò, A., Caiti, A.: An evaluation of deep water navigation systems for autonomous underwater vehicles. *IFAC-PapersOnLine* **50**(1), 13,680–13,685 (2017)
16. Do, K., Jiang, Z., Pan, J., Nijmeijer, H.: Global output feedback universal controller for stabilization and tracking of underactuated odin-an underwater vehicle. In: *Decision and Control, 2002, Proceedings of the 41st IEEE Conference on*, vol. 1, pp. 504–509. IEEE (2002)
17. Do, K., Pan, J., Jiang, Z.: Robust and adaptive path following for underactuated autonomous underwater vehicles. *Ocean Engineering* **31**(16), 1967–1997 (2004)
18. Do, K.D.: Robust adaptive tracking control of underactuated odins under stochastic sea loads. *Robotics and Autonomous Systems* **72**, 152–163 (2015)
19. Dong, W., Guo, Y.: Global time-varying stabilization of underactuated surface vessel. *IEEE Transactions on Automatic Control* **50**(6), 859–864 (2005)
20. Dong, Z., Wan, L., Li, Y., Liu, T., Zhuang, J., Zhang, G.: Point stabilization for an underactuated auv in the presence of ocean currents. *International Journal of Advanced Robotic Systems* **12**(7), 100 (2015)
21. Encarnacao, P., Pascoal, A.: 3D path following for autonomous underwater vehicle. In: *Proceedings of the 39th IEEE Conference on Decision and Control* (2000)
22. Encarnacao, P., Pascoal, A.: Combined trajectory tracking and path following: an application to the coordinated control of autonomous marine craft. In: *Proceedings of the 40th IEEE Conference on Decision and Control*, vol. 1, pp. 964–969 (2001)
23. Fossen, T.I.: Marine control systems: guidance, navigation and control of ships, rigs and underwater vehicles. *Marine Cybernetics AS* (2002)
24. Fossen, T.I.: *Handbook of marine craft hydrodynamics and motion control*. John Wiley & Sons (2011)
25. Fujii, T., Ura, T.: Development of motion control system for AUV using neural nets. In: *Proceedings of the (1990) IEEE Symposium on Autonomous Underwater Vehicle Technology*, pp. 81–86 (1990)
26. Gao, J., Liu, C., Proctor, A.: Nonlinear model predictive dynamic positioning control of an underwater vehicle with an onboard usbl system. *Journal of Marine Science and Technology* **21**(1), 57–69 (2016)
27. Healey, A.J., Lienard, D.: Multivariable sliding mode control for autonomous diving and steering of unmanned underwater vehicles. *IEEE Journal of Oceanic Engineering* **18**(3), 327–339 (1993)
28. Jia-Wang, L., Bao-Wei, S., Cheng, S.: Tracking control of autonomous underwater vehicles with internal moving mass. *ACTA Automatica Sinica* **34**(10), 1319–1323 (2008)
29. Jiang, Z.P.: Global tracking control of underactuated ships by lyapunov’s direct method. *Automatica* **38**(2), 301–309 (2002)
30. Joe, H., Kim, M., Yu, S.c.: Second-order sliding-mode controller for autonomous underwater vehicle in the presence of unknown disturbances. *Nonlinear Dynamics* **78**(1), 183–196 (2014)
31. Khaled, N., Chalhoub, N.G.: A self-tuning guidance and control system for marine surface vessels. *Nonlinear Dynamics* **73**(1-2), 897–906 (2013)
32. Lapierre, L., Jouvencel, B.: Robust nonlinear path-following control of an AUV. *IEEE Journal of Oceanic Engineering* **33**(2), 89–102 (2008)
33. Lapierre, L., Soetanto, D.: Nonlinear path-following control of an AUV. *Ocean Engineering* **34**(11), 1734–1744 (2007)
34. Lefeber, E., Pettersen, K.Y., Nijmeijer, H.: Tracking control of an underactuated ship. *IEEE transactions on control systems technology* **11**(1), 52–61 (2003)

35. Li, J.H., Lee, P.M.: Design of an adaptive nonlinear controller for depth control of an autonomous underwater vehicle. *Ocean engineering* **32**(17), 2165–2181 (2005)
36. Ma, B.L.: Global κ -exponential asymptotic stabilization of underactuated surface vessels. *Systems & Control Letters* **58**(3), 194–201 (2009)
37. McGann, C., Py, F., Rajan, K., Ryan, J.P., Henthorn, R.: Adaptive control for autonomous underwater vehicles. In: Proceedings of the 23rd national conference on Artificial intelligence-Volume 3, pp. 1319–1324 (2008)
38. Nguyen, K.D., Dankowicz, H.: Adaptive control of underactuated robots with unmodeled dynamics. *Robotics and Autonomous Systems* **64**, 84–99 (2015)
39. Panagou, D., Kyriakopoulos, K.J.: Dynamic positioning for an underactuated marine vehicle using hybrid control. *International Journal of Control* **87**(2), 264–280 (2014)
40. Peng, Z., Wang, D., Wang, H., Wang, W.: Distributed coordinated tracking of multiple autonomous underwater vehicles. *Nonlinear Dynamics* **78**(2), 1261–1276 (2014)
41. Pettersen, K.Y., Nijmeijer, H.: Underactuated ship tracking control: theory and experiments. *International Journal of Control* **74**(14), 1435–1446 (2001)
42. Prestero, T.T.J.: Verification of a six-degree of freedom simulation model for the REMUS autonomous underwater vehicle (2001)
43. Refsnes, J.E., Sorensen, A.J., Pettersen, K.Y.: Model-based output feedback control of slender-body underactuated AUVs: theory and experiments. *IEEE Transactions on Control Systems Technology* **16**(5), 930–946 (2008)
44. Repoulas, F., Papadopoulos, E.: Planar trajectory planning and tracking control design for underactuated AUVs. *Ocean Engineering* **34**(11), 1650–1667 (2007)
45. Sahu, B.K., Subudhi, B.: Adaptive tracking control of an autonomous underwater vehicle. *International Journal of Automation and Computing* **11**(3), 299–307 (2014)
46. Sankaranarayanan, V., Mahindrakar, A.D., Banavar, R.N.: A switched controller for an underactuated underwater vehicle. *Communications in Nonlinear Science and Numerical Simulation* **13**(10), 2266–2278 (2008)
47. Von Alt, C., Allen, B., Austin, T., Stokey, R.: Remote environmental measuring units. In: Proceedings of the 1994 IEEE Symposium on Autonomous Underwater Vehicle Technology, pp. 13–19 (1994)
48. Wang, H., Wang, D., Peng, Z.: Adaptive dynamic surface control for cooperative path following of marine surface vehicles with input saturation. *Nonlinear Dynamics* **77**(1-2), 107–117 (2014)
49. Wang, J.S., Lee, C.G.: Self-adaptive recurrent neuro-fuzzy control of an autonomous underwater vehicle. *IEEE Transactions on Robotics and Automation* **19**(2), 283–295 (2003)
50. Wang, L., Jia, H.m., Zhang, L.j., Wang, H.b.: Horizontal tracking control for AUV based on nonlinear sliding mode. In: Proceedings of the IEEE International Conference on Information and Automation (ICIA), pp. 460–463 (2012)
51. Watson, S.A., Green, P.N.: Depth control for micro-autonomous underwater vehicles (μ auvs): Simulation and experimentation. *International Journal of Advanced Robotic Systems* **11**(3), 31 (2014)
52. Wichlund, K., Sørtdalen, O.J., Egeland, O.: Control properties of underactuated vehicles. In: Proceedings of the IEEE International Conference on Robotics and Automation, vol. 2, pp. 2009–2014 (1995)
53. Yuh, J.: A neural net controller for underwater robotic vehicles. *IEEE Journal of Oceanic Engineering* **15**(3), 161–166 (1990)
54. Yuh, J.: Learning control for underwater robotic vehicles **14**(2), 39–46 (1994)