

## MIT Open Access Articles

*Solid core PCF-based mode selector  
for MDM-Ro-FSO transmission systems*

The MIT Faculty has made this article openly available. **Please share** how this access benefits you. Your story matters.

**As Published:** <https://doi.org/10.1007/s11107-018-0778-4>

**Publisher:** Springer US

**Persistent URL:** <https://hdl.handle.net/1721.1/131888>

**Version:** Author's final manuscript: final author's manuscript post peer review, without publisher's formatting or copy editing

**Terms of Use:** Article is made available in accordance with the publisher's policy and may be subject to US copyright law. Please refer to the publisher's site for terms of use.



# Solid Core PCF based Mode Selector for MDM-Ro-FSO Transmission Systems

Sushank Chaudhary<sup>1</sup>

Angela Amphawan<sup>1,2</sup>

1 Optical Computing and Technology Research Laboratory, School of Computing, Universiti Utara Malaysia, Malaysia.

2 Research Laboratory of Electronics, Massachusetts Institute of Technology, Cambridge, USA.

Corresponding Author: sushankchaudhary@gmail.com

## Abstract:

Radio-over-free-space (Ro-FSO) technology is a combination of free-space optics (FSO) and wireless communication systems. It plays a significant role in radio-frequency signal transmission in mobile network communication through high-speed optical carrier without any licensing and costly cables. Photonic crystal fibers also play a significant role to deliver data at faster rate for short haul communication. This paper, for the first time to the author's best knowledge, utilizes mode division multiplexing in conjunction with solid core PCFs to transmit 2 x 2.5Gbps-5GHz data over 2.5 km free space link. The results are reported in terms of Bit error rate (BER), spatial profiles of received modes, mode spectrum of modes and eye diagrams. Furthermore, proposed PCF-MDM-Ro-FSO transmission system is also reported under the impact of atmospheric turbulences.

**Keywords:** Radio over Free Space, Photonic Crystal Fiber, Mode Spectrum, Mode Division Multiplexing, Atmospheric turbulences

## I Introduction

The development of online multimedia services gave rise to the number of cellular subscribers to 7.5 billion last year, as reported by the International Telecommunication Union (ITU) [1]. This has further augmented the relevance of radio frequency (RF) spectrum among wireless operators. Wireless network infrastructure has played a significant role in Ro-FSO technology, where subscribers transmit RF signals via a high-speed optical carrier without expensive optical fiber cabling or RF licensing [2-5]. Ro-FSO technology can be used for exploiting a different segment of the electromagnetic spectrum for the mobile networks while emphasizing RF spectrum congestion issues in current wireless networks. This technology can be utilized for a number of processes including RF up-down conversion, handoff, switching, coding and multiplexing, either centralized or shared among all base stations [6]. Compatible with existing mobile cellular architectures, Ro-FSO **a)** allocates RF signals at high bandwidth, **b)** features low attenuation losses, and **c)** consumes less power [7, 8]. Ro-FSO may pave the way towards a ubiquitous platform for seamless integration of radio and optical networks without expensive optical fiber cabling in WLANs [9]. Recent developments in Ro-FSO include experimental measurements [9-11] and mathematical modeling [12-15] under atmospheric turbulence and scintillation effects. To increase the capacity of Ro-FSO systems, multiplexing in the wavelength [16], intensity [17] and polarization [18] dimensions has been demonstrated. The eigen-mode dimension has

garnered significant momentum in recent years for multiplexing disparate data streams in mode division multiplexing (MDM). MDM has been implemented in optical fiber communications through digital holograms [19, 20], optical signal processing [21, 22] and photonic crystal fiber (PCF) [23, 24]. MDM-based Ro-FSO can be used for defense and security applications [3, 25]. MDM can be utilized for enhancing system capacity and security against physical layer attacks. In the recent years, researchers have demonstrated efficient role of MDM in free space optical networks [26, 27]. A study in 2016 [28] implemented the super-positions of  $\ell=\pm 1, \pm 2$  and  $\pm 3$  at various relative phases to encode information while transmitting orbital angular momentum (OAM) mode of light over 143 km free space link between two islands. Further, the relative phases showed rotation in mode structure based on the intensity of each mode. This technique was previously utilized for checking the transmission quality in classical [29] and quantum [30] experiments over 3 km intra-city link. In 2016 [31], researcher have demonstrated the transmission of 1.44Tb/s over 1.8m FSO link by employing pulse amplitude modulation (PAM), OAM and polarization division multiplexing (PDM). In this experiment, 24 OAM modes are generated by using spatial laser modulators and PDM scheme. In another experiment [32], researchers have transmitted 40Gbps 16 QAM signals over 260m FSO link by using OAM technique. In this experiment, two OAM modes ( $\ell=\pm 3$ ) are generated by using two SLM's. In 2015 [33], authors has shown 100 Gbps data transmitting over 1.15 km of low loss photonic band gap fiber and 1 km of solid core fiber. The reported results show that mode coupling to higher-order modes has resulted in minimal OSNR penalty associated with SCF and  $\sim 1-2$  dB penalty associated with HC-PBGF. In another work [34], authors have shown zero dispersion PCF to minimize dispersion in optical fiber communication systems. The reported results show that the proposed PCF with its low confinement loss can be useful in sensor and communication applications. In 2016 [23], authors has shown dual core PCF for mode conversion (between LP 01 and LP 11 modes, and LP 01 and LP 21 modes). In another work [35], authors have shown mode selective coupler based on dual core PCF for mode conversion between LP 01 and LP 11 modes. In 2017 [36], authors has reported polarization beam splitters based on dual core PCF with magnetic fluids in air holes.

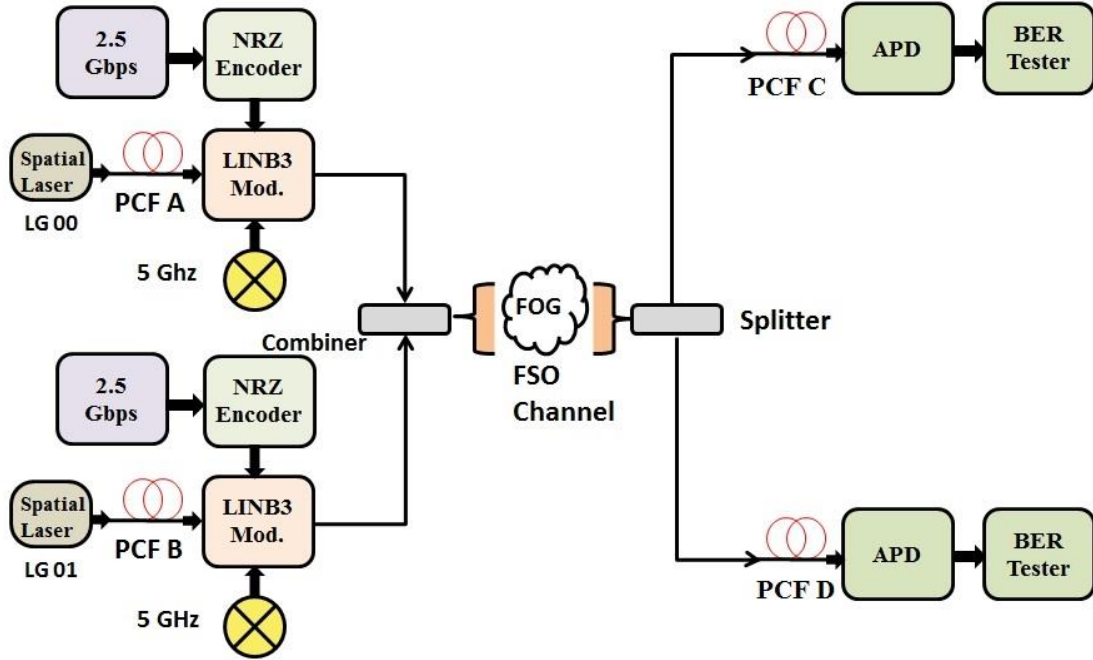
The current paper aims to investigate, for the first time to the author's best knowledge, the potentials of SC-PCF for mode selection in MDM-Ro-FSO networks.

In this work, 2 X 2.5Gbps-5GHz data is transported over 2 km free space link by using mode division multiplexing of LG 01 and LG 02 modes in conjunction with two PCFs at transmitter side and two PCF's at receiver side to provide mode equalization, which is not reported in any previous works. The rest of the paper is divided as follows: Section II describes proposed model and structure of PCF, Section III presents the result and discussion part followed by section IV which presents the conclusion of this work.

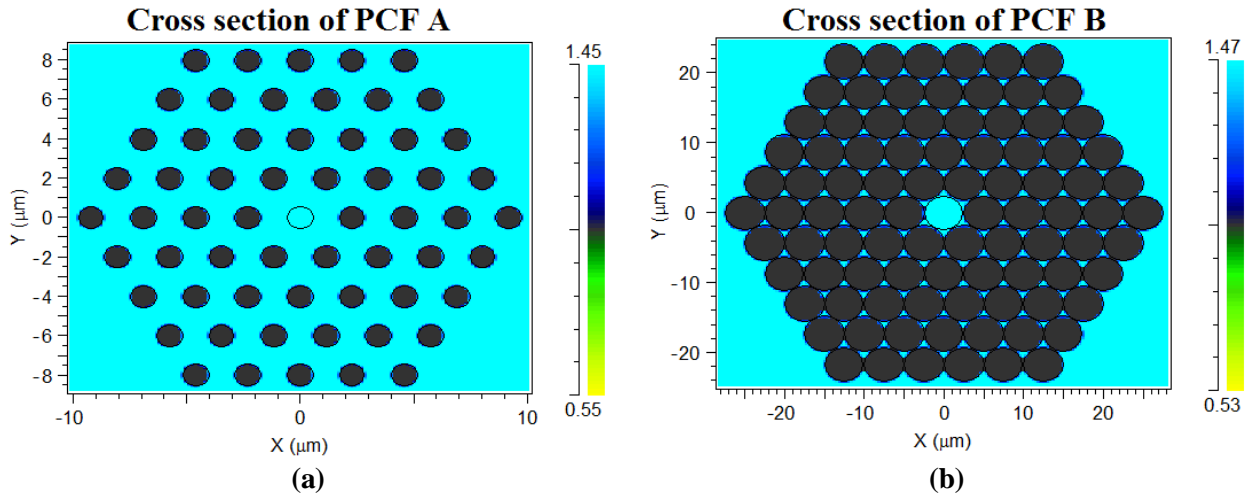
## II Simulation Set up

A schematic diagram of 2 x 2.5Gbps-5GHz proposed hybrid MDM-PCF-Ro-FSO transmission system, simulated in OptSim<sup>TM</sup> and BeamProp<sup>TM</sup> software, is illustrated in Figure 1. Two independent non return to zero (NRZ) encoded Channels, excited from two different PCFs, are transmitted over 2 km free space link. Each Channel carries 2.5Gbps-5GHz data modulated simultaneously by LiNb3 optical modulator. Two distinct modes LG 00 and LG 01 are excited from spatial laser. Channel 1 is operated on LG 00 mode in conjunction with PCF A whereas channel 2 is operated on LG 01 in conjunction with PCF B. Figure 2 represents internal core

structures of PCF A and PCF B. Spatial laser is used to generate LG 00 and LG 01 modes, polarized in x-direction.



**Figure 1:** 2 x 2.5Gbps-5GHz Hybrid MDM-PCF-Ro-FSO Transmission System

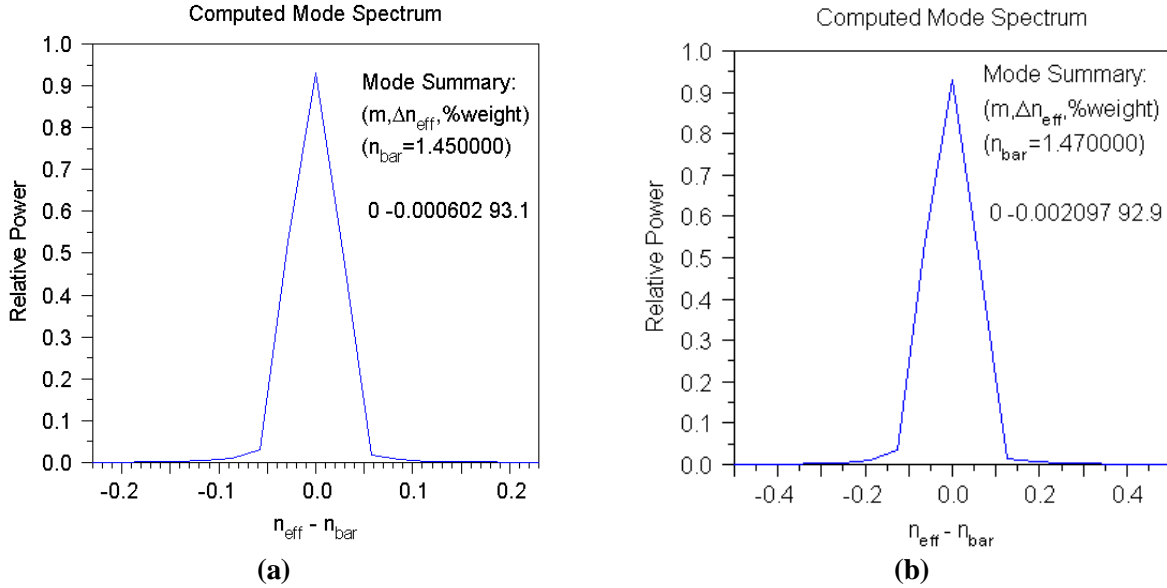


**Figure 2:** Structures of PCFs (a) PCF A (b) PCF B

The mathematical description of the LG mode is given as [37]:

$$\psi_{m,n}(r, \varphi) = \left( \frac{2r^2}{\omega_o^2} \right)^{\frac{|n|}{2}} L_m^n \left( \frac{2r^2}{\omega_o^2} \right) \exp \left( -\frac{r^2}{\omega_o^2} \right) \times \exp \left( j \frac{\pi r^2}{\lambda R_o} \right) \begin{cases} \sin(|n| \varphi), n \geq 0 \\ \cos(|n| \varphi), n < 0 \end{cases} \quad (1)$$

The laser beam is then coupled into PCF structures having length of 10 micrometer. Figure 3 represents computed mode spectrum of PCF A and PCF B. As shown in Figure 3 when LG 00 is launched into PCF A, 93.1 % of power is computed in dominant mode at the output of PCF A with effective index of 1.45 whereas when LG 01 mode is launched into PCF B, 92.9 % of power is computed in dominant mode at output of PCF B with effective index of 1.47.

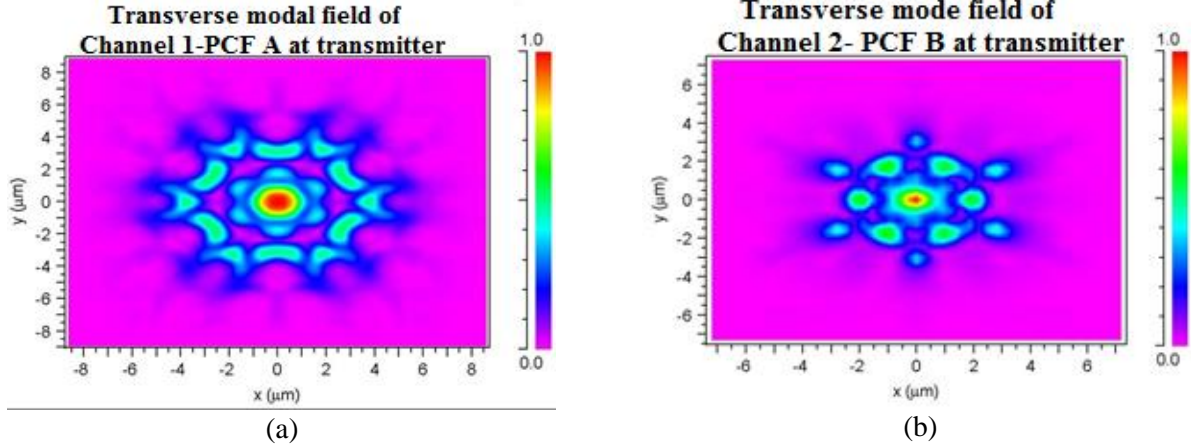


**Figure 3:** Computed Mode Spectrum (a) After PCF A (b) After PCF B

Similarly, Figure 4 depicts the transmitted transverse modal field of PCF A and PCF B. Coupling between mode groups is modelled based on an iterative method [38]:

$$\frac{\partial P_q}{\partial Z} + \frac{1}{v_g} \frac{\partial P_q}{\partial t} = -\alpha_q P_q + k_q d_q (P_{q+1} - P_q) - \gamma_{q-1} d_{q-1} (P_q - P_{q-1}) \quad (2)$$

Where ' $q$ ' is the mode number, ' $P_q(z, t)$ ' is the average power signal, ' $v_g$ ' is the group velocity, ' $\alpha_q$ ' is the power attenuation coefficient, ' $d_q$ ' is the mode coupling coefficient between the mode groups ' $q$ ' and ' $q+1$ ', ' $k_q$ ' and ' $\gamma_{q-1}$ ' are degeneracy factors. The other parameters of PCF A, PCF B at transmitter side and PCF C, PCF D at receiver side are illustrated in table 1. The 2.5 km FSO link is used for transmitting the combined output of two channels.



**Figure 4:** Transmitted transverse modal field (a) Channel 1- PCF A (b) Channel 2- PCF B

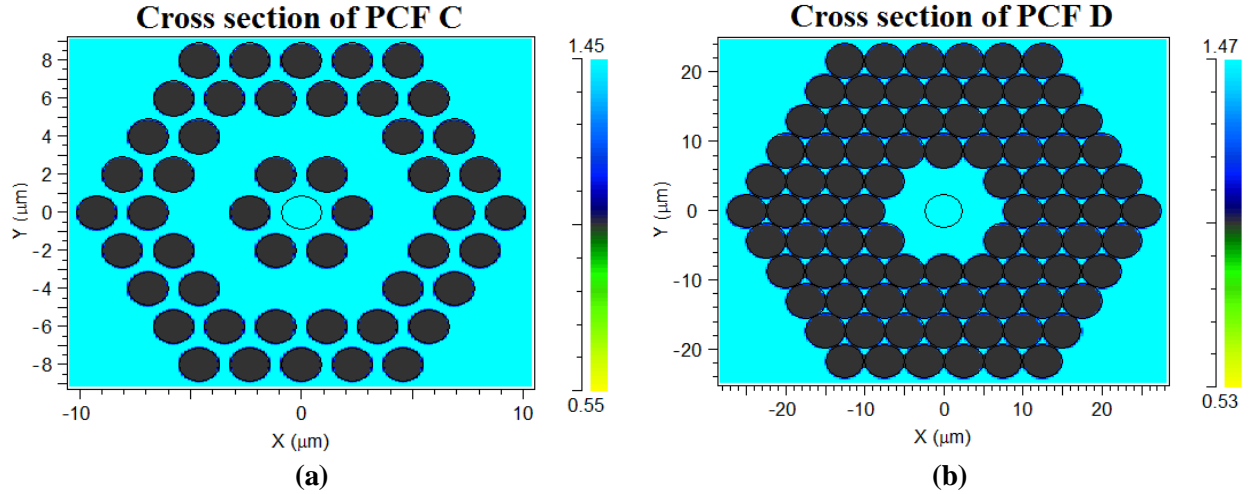
Parameters	PCF A	PCF B	PCF C	PCF D
No of Rings	4	5	4	5
Diameter of Air Holes, $d$ ( $\mu\text{m}$ )	1	2	1.6	2
Distance between air holes, $g$ ( $\mu\text{m}$ )	2.3	5	2.3	5
Ratio of Distance between Air holes to diameter of air holes, $g/d$	2.3	2.5	1.4375	2.5

**Table 1:** Parameters of PCFs at Transmitter Side and Receiver Side

The mathematical description of FSO link described as [37]:

$$P_{\text{Received}} = P_{\text{Transmitted}} \frac{d_R^2}{(d_T + \theta R)^2} 10^{\alpha R/10} \quad (3)$$

whereas ' $d_R$ ' defines receiver aperture diameter, ' $d_T$ ' is the transmitter aperture diameter, ' $\theta$ ' is the beam divergence, ' $R$ ' is the range, ' $\alpha$ ' is the atmospheric attenuation. The performance of the proposed Ro-FSO system under atmospheric turbulences is evaluated by considering atmospheric attenuation value as 0.14 dB/km, 9 dB/km, 16 dB/km, and 22 dB/km in clear weather conditions, thin fog, thick fog, and heavy fog respectively [39, 40]. At the receiving side, optical beam is divided into two PCFs C and D for decomposing the transmitted modes. The structures of PCF C and PCF D are slightly different and flipped with respect to PCF A and PCF B, so that relevant mode is selected as shown in Figure 5.

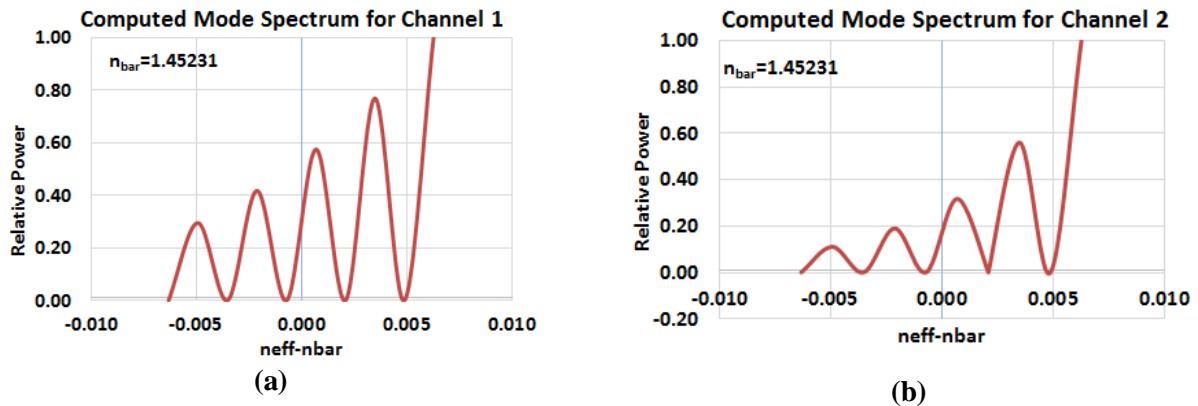


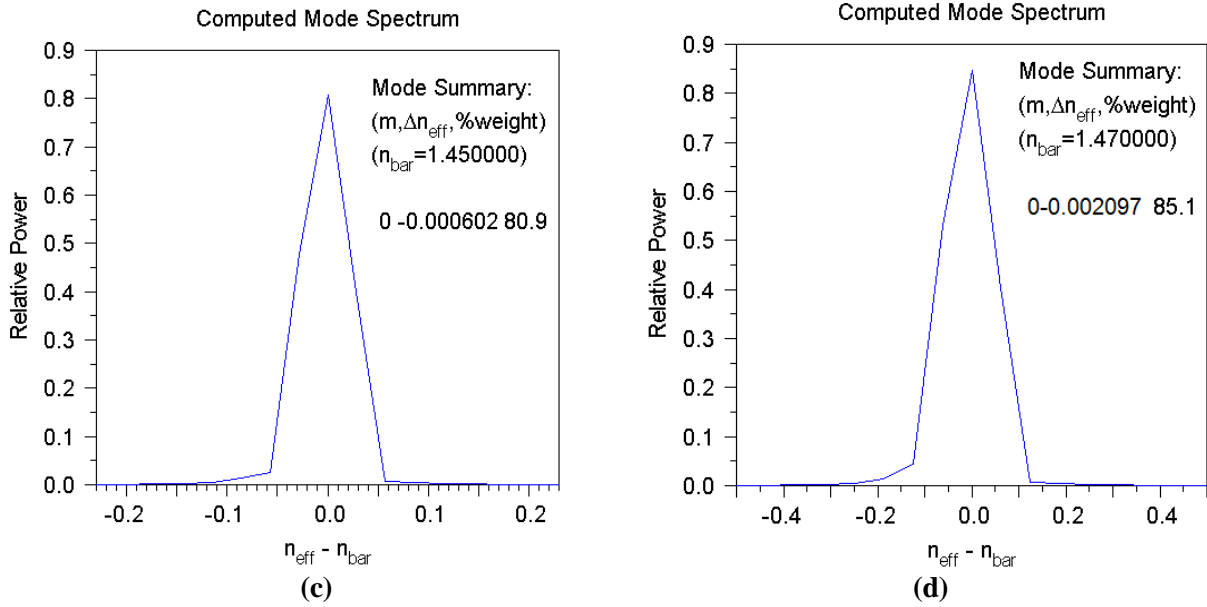
**Figure 5:** PCF Structures (a) PCF C (b) PCF D

The effective index of PCF C is set at 1.45 in order to synchronize with PCF A, whereas effective index of PCF D is set at 1.47 in order to synchronize with PCF B. After the PCFs, the optical beam is converted to electrical signal with the help of spatial photodetector, with aperture area of  $10\mu\text{m}$ , followed by bit error rate tester.

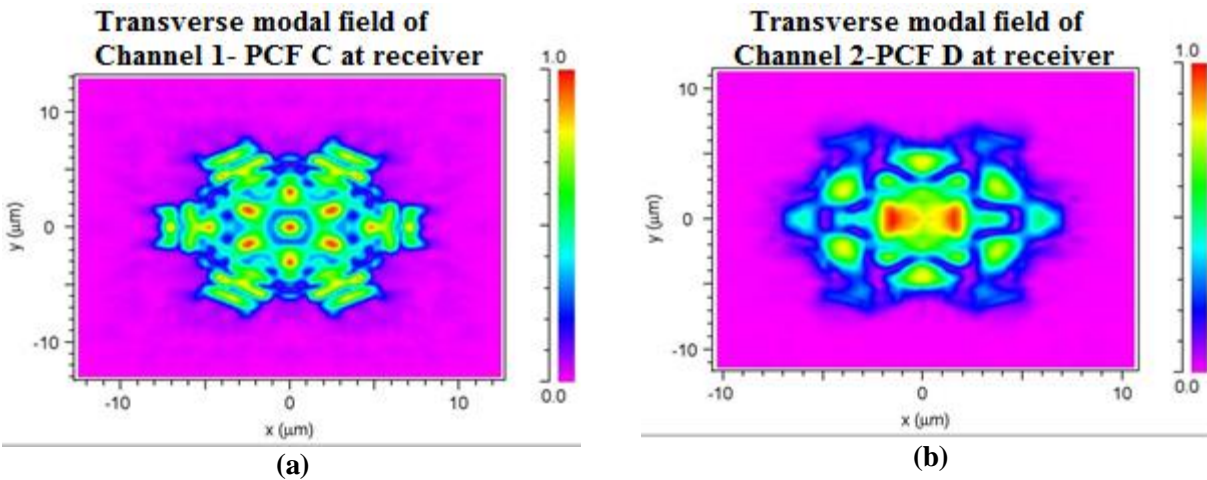
### III Results and Discussion

In this section, the results from simulation of proposed hybrid MDM-PCF-Ro-FSO system are discussed and presented. Figure 6 shows the computed mode spectrum before the PCFs as well as after the PCFs at receiving side. It has been reported that 80% of optical power in dominant mode is achieved at output of PCF C with effective index of 1.45, whereas 85.1% of power in dominant mode is achieved at output of PCF D with effective index of 1.47. Whereas without PCF only 20 % and 40 % of power is noted in dominant modes for both channel 1 and channel 2 respectively. Figure 7 represents the received modes at receiver sides after FSO link of 2 km. PCF C and PCF D are used to compensate lost power and attenuation introduced in FSO transmission Channel. Similarly, Figure 8 shows the measured BER of Channel 1 and Channel 2 with and without PCF conjunction. High improvement in BER is noted in case of PCF conjunction as compared to without PCF equalization.



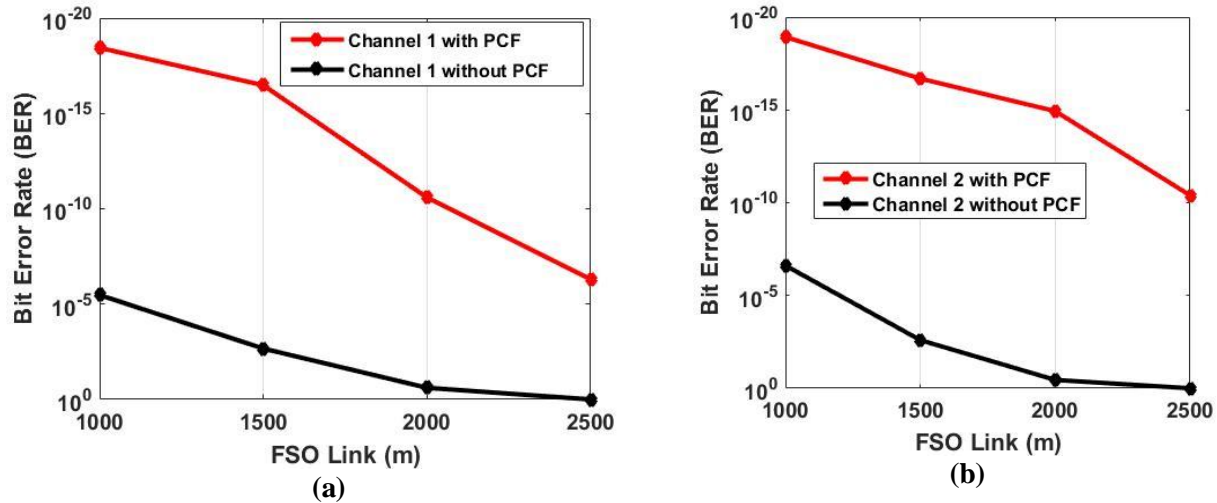


**Figure 6:** Computed Mode Spectrum at Receiver Side (a) after FSO Channel 1 (b) after FSO Channel 2 (c) PCF C (d) PCF D



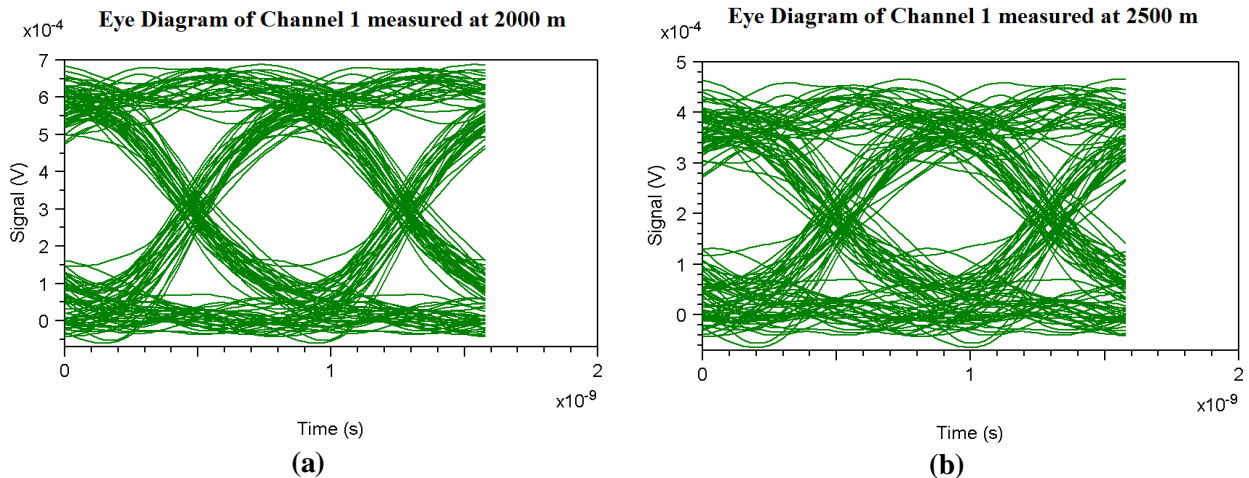
**Figure 7:** Received transverse modal field at FSO link of 2km (a) Channel 1- PCF C (b) Channel 2-PCF D

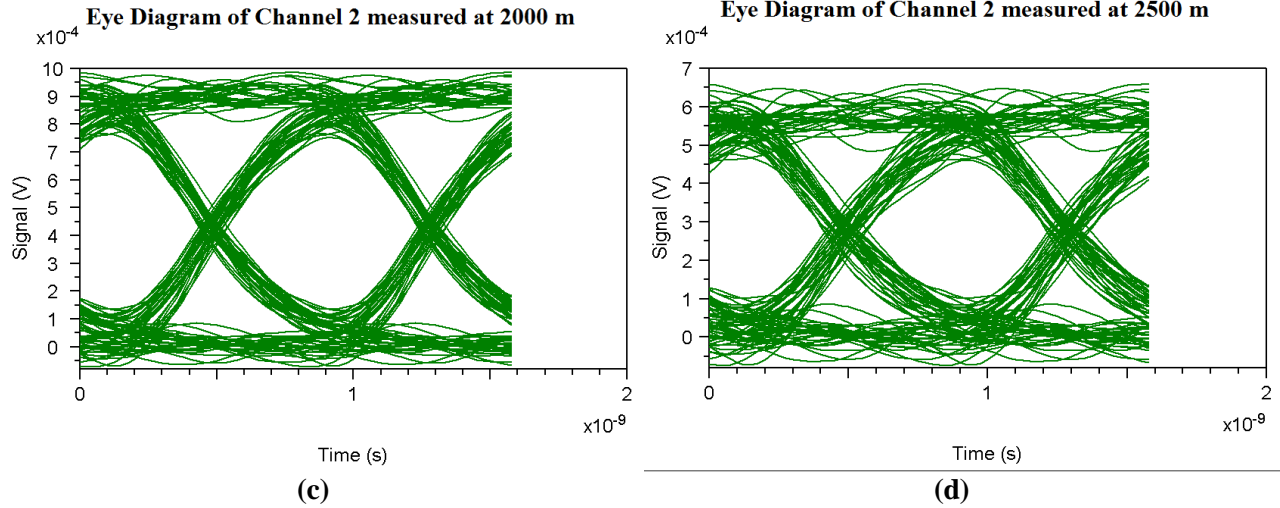




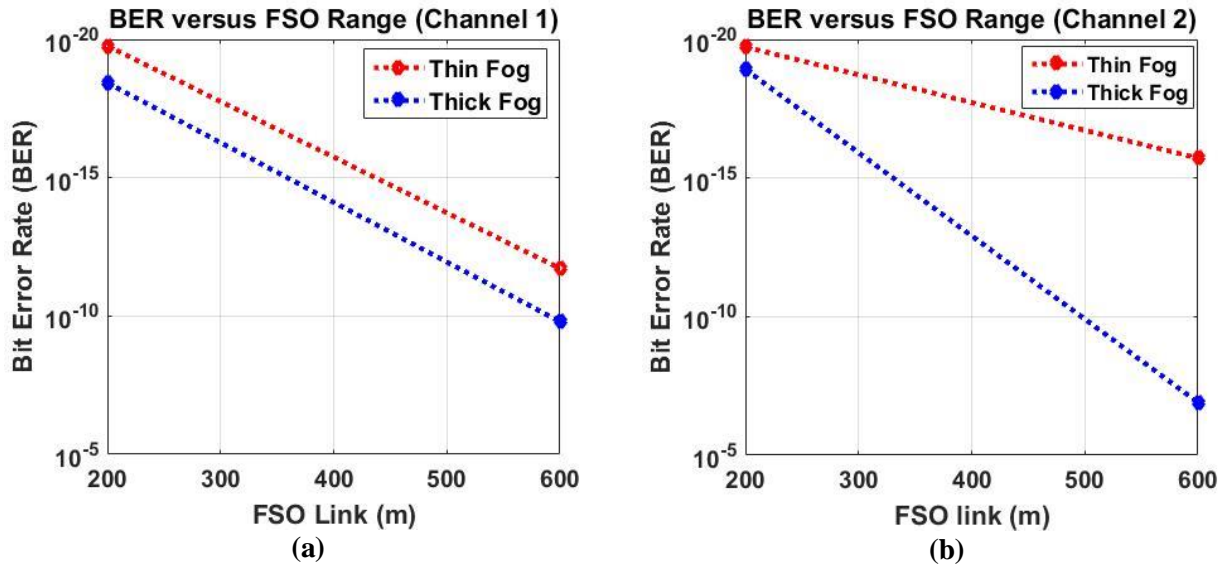
**Figure 8:** Measured BER with and without PCF Equalization (a) Channel 1 (b) Channel 2

BER for channel 1 with PCF equalization is noted as  $3.6292 \times 10^{-19}$ ,  $2.5599 \times 10^{-11}$  and  $5.0078 \times 10^{-7}$  as compared to without PCF equalization for which it is noted as  $3.3421 \times 10^{-6}$ ,  $2.4526 \times 10^{-1}$  and 1 at the FSO link distance of 1000 m, 2000 m and 2500 m respectively. Consequently, BER for channel 2 with PCF equalization is computed as  $1.1828 \times 10^{-19}$ ,  $1.1695 \times 10^{-15}$  and  $4.0422 \times 10^{-11}$  as compared to without PCF equalization for which it is noted as  $2.4351 \times 10^{-7}$ ,  $3.5434 \times 10^{-1}$  and 1 at the FSO link distance of 1000 m, 2000 m and 2500 m respectively. The measured eye diagrams are shown in Figure 9, which indicates that with PCF equalization, the FSO link is extended to 2.5 km with required BER and eye diagrams.



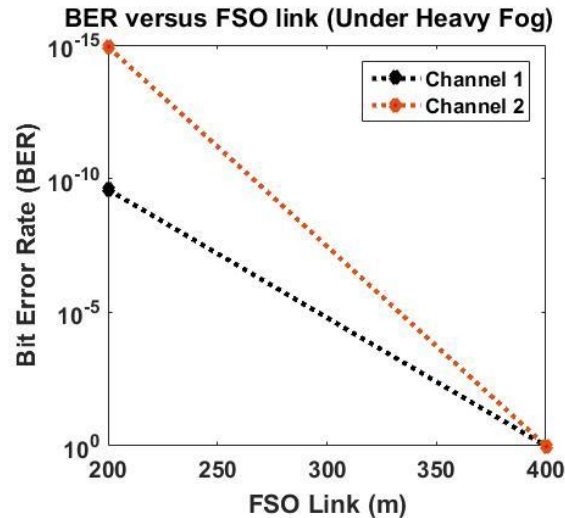


**Figure 9:** Measured Diagrams (a) Channel 1 at 2000m (b) Channel 1 at 2500m (c) Channel 2 at 2000m (d) Channel 2 at 2500m



**Figure 10:** Evaluation of Proposed Hybrid PCF-MDM System under atmospheric attenuations (a) Channel 1 (b) Channel 2

Similarly, Figure 10 represents evaluation of proposed hybrid PCF-MDM transmission system under impact of atmospheric attenuations. It indicates that under impact of thin fog, BER for Channel 1 is computed as  $1.7157 \times 10^{-20}$  and  $1.9138 \times 10^{-12}$ ; under thick fog it is  $3.7344 \times 10^{-19}$  and  $1.6031 \times 10^{-4}$  at link distance of 200 m and 600 m. Whereas for Channel 2, under thin fog, it is computed as  $1.8737 \times 10^{-20}$  and  $1.2229 \times 10^{-16}$ ; under thick fog it is  $1.2026 \times 10^{-19}$  and  $1.2471 \times 10^{-7}$ ; link distance of 200 m and 600 m. Figure 11 shows the evaluation of BER for channel 1 and channel 2 under influence of heavy fog. The value of BER for channel 1 is measured as  $2.5599 \times 10^{-11}$  and 1 whereas for channel 2 it is measured as  $1.1695 \times 10^{-15}$  and 1 at FSO link distance of 200 m and 400m.



**Figure 11: BER versus FSO Link under heavy fog**

Thus, under atmospheric turbulences, the FSO link for channel 1 and channel 2 prolongs to 600 m under thin fog, 400 m under thick fog and 200 m under heavy fog with acceptable BER of  $\approx 10^{-10}$ .

#### IV Conclusion

The current work is based on transmission of two channels, having 2.5Gbps-5GHz NRZ encoded data each, operated on LG 01 in conjunction with PCF A and LG 02 in conjunction with PCF B are transmitted over 2.5 km FSO link. The results are reported in terms of received spatial profiles of transmitted modes, mode spectrum at receiver side, BER and eye diagrams. It is concluded from the reported results that each channel is transmitted and received successfully over 2.5 km FSO link with acceptable BER and eye diagrams. The use of PCF both at transmitter and receiver side shows significant improvement in data transmission. The FSO link for both channels extends to 2.5 km with required BER in clear weather, whereas when atmospheric conditions changes to thin fog, it prolongs to 600 m; for thick fog it prolongs to 400 m; for heavy fog it prolongs to 200 m with acceptable BER of  $\approx 10^{-10}$ .

#### References

- [1] ITU, "Facts and Figures 2015," 2015.
- [2] A. Amphawan, S. Chaudhary, R. Din, and M. N. Omar, "5Gbps HG 0, 1 and HG 0, 3 optical mode division multiplexing for RoFSO," in *Signal Processing & Its Applications (CSPA), 2015 IEEE 11th International Colloquium on*, 2015, pp. 145-149.
- [3] A. Amphawan, S. Chaudhary, T. Elfouly, and K. Abualsaud, "Optical Mode Division Multiplexing for Secure Ro-FSO WLANs," *Advanced Science Letters*, vol. 21, pp. 3046-3049, 2015.
- [4] K. Kazaura, K. Wakamori, M. Matsumoto, T. Higashino, K. Tsukamoto, and S. Komaki, "RoFSO: a universal platform for convergence of fiber and free-space optical communication networks," *IEEE Communications Magazine*, vol. 48, pp. 130-137, 2010.

- [5] M. Matsumoto, "Next generation free-space optical system by system design optimization and performance enhancement," in *Progress In Electromagnetics Research Symposium Proceedings, KL, MALAYSIA, March, 2012*, pp. 27-30.
- [6] K. Prabu, R. Rajendran, and D. S. Kumar, "Spectrum analysis of radio over free space optical communications systems through different channel models," *Optik-International Journal for Light and Electron Optics*, vol. 126, pp. 1142-1145, 2015.
- [7] A. Bekkali, P. T. Dat, K. Kazaura, K. Wakamori, M. Matsumoto, T. Higashino, *et al.*, "Performance evaluation of an advanced DWDM RoFSO system for transmitting multiple RF signals," *IEICE transactions on fundamentals of electronics, communications and computer sciences*, vol. 92, pp. 2697-2705, 2009.
- [8] S. Chaudhary and A. Amphawan, "The role and challenges of free-space optical systems," *Journal of Optical Communications*, vol. 35, pp. 327-334, 2014.
- [9] A. Amphawan, S. Chaudhary, H. Samad, J. Ahmad, and K. Poly-Tech, "Mode Division Multiplexing of LG and HG modes in Ro-FSO," 2015.
- [10] J. Bohata, S. Zvanovec, P. Pesek, T. Korinek, M. M. Abadi, and Z. Ghassemlooy, "Experimental verification of long-term evolution radio transmissions over dual-polarization combined fiber and free-space optics optical infrastructures," *Applied optics*, vol. 55, pp. 2109-2116, 2016.
- [11] K. Kazaura, P. Dat, A. Bekkali, A. Shah, T. Suzuki, K. Wakamori, *et al.*, "Experimental evaluation of a radio-on-FSO communication system for multiple RF signal transmission," in *SPIE LASE: Lasers and Applications in Science and Engineering*, 2009, pp. 719907-719907.
- [12] K.-H. Kim, H. Onodera, T. Higashino, K. Tsukamoto, S. Komaki, Y. Aburakawa, *et al.*, "A new statistical model of scintillation in RoFSO link and performance evaluation of WLAN system," in *Microwave photonics, 2008. jointly held with the 2008 asia-pacific microwave photonics conference. mwp/apmp 2008. international topical meeting on*, 2008, pp. 193-196.
- [13] F. J. López-González, J. M. Garrido-Balsells, A. Jurado-Navas, M. Castillo-Vázquez, and A. Puerta-Notario, "Performance Analysis of M-atmospheric FSO Links," in *Propagation Through and Characterization of Atmospheric and Oceanic Phenomena*, 2016, p. Tu4A.4.
- [14] H. Nistazakis, M. Ninos, A. Tsigopoulos, D. Zervos, and G. Tombras, "Performance study of terrestrial multi-hop OFDM FSO communication systems with pointing errors over turbulence channels," *Journal of Modern Optics*, vol. 63, pp. 1403-1413, 2016.
- [15] H. Nistazakis, A. Stassinakis, H. Sandalidis, and G. Tombras, "QAM and PSK OFDM RoFSO Over-Turbulence Induced Fading Channels," *IEEE Photonics Journal*, vol. 7, pp. 1-11, 2015.
- [16] P. Pesek, J. Bohata, S. Zvanovec, and J. Perez, "Analyses of dual polarization WDM and SCM Radio over Fiber and Radio over FSO for C-RAN architecture," in *Wireless and Optical Communication Conference (WOCC), 2016 25th*, 2016, pp. 1-4.
- [17] H. Nistazakis, M. Ninos, A. Stassinakis, A. Tsigopoulos, and G. Tombras, "New Performance Results for QAM OFDM RoFSO Over K and Exponentially Modeled Turbulence Channels," 2014.
- [18] D. Kong, J. Wu, T. Xu, Y. Li, M. Yu, D. Zheng, *et al.*, "160 Gbaud Single Nyquist Channel Transmission through Emulated 4 km Free-space Turbulence Link," in *CLEO: Science and Innovations*, 2015, p. SW4M.4.

- [19] L. Huang, J. Leng, P. Zhou, S. Guo, and H. Lü, "Adaptive mode control of a few-mode fiber by real-time mode decomposition," *Optics express*, vol. 23, pp. 28082-28090, 2015.
- [20] C. Rosales-Guzmán, A. Trichili, A. Dudley, B. Ndagano, A. B. Salem, M. Zghal, *et al.*, "Holographic toolkit for optical communication beyond orbital angular momentum," in *SPIE Optical Engineering+ Applications*, 2016, pp. 99500C-99500C-10.
- [21] J. M. Kahn, S. Ö. Arik, and K. P. Ho, "MIMO channel statistics and signal processing in mode-division multiplexing systems," in *2015 IEEE 16th International Workshop on Signal Processing Advances in Wireless Communications (SPAWC)*, 2015, pp. 440-444.
- [22] K. Shibahara, T. Mizuno, D. Lee, and Y. Miyamoto, "Dense SDM transmission employing advanced MIMO signal processing," in *Photonics Society Summer Topical Meeting Series (SUM), 2016 IEEE*, 2016, pp. 142-143.
- [23] S. Cai, S. Yu, Y. Wang, M. Lan, L. Gao, and W. Gu, "Hybrid Dual-Core Photonic Crystal Fiber for Spatial Mode Conversion," *IEEE Photonics Technology Letters*, vol. 28, pp. 339-342, 2016.
- [24] H. Zhang, W. Zhang, L. Xi, X. Tang, X. Zhang, and X. Zhang, "A New Type Circular Photonic Crystal Fiber for Orbital Angular Momentum Mode Transmission," *IEEE Photonics Technology Letters*, vol. 28, pp. 1426-1429, 2016.
- [25] A. Amphawan, S. Chaudhary, and B. B Gupta, "Secure MDM-OFDM-Ro-FSO System Using HG Modes," *International Journal of Sensors Wireless Communications and Control*, vol. 5, pp. 13-18, 2015.
- [26] A. Amphawan and S. Chaudhary, "Free-space optical mode division multiplexing for switching between millimeter-wave picocells," in *International Conference on Optical and Photonic Engineering (icOPEN2015)*, 2015, pp. 95242H-95242H-6.
- [27] A. Amphawan, S. Chaudhary, and V. Chan, "2 x 20 Gbps-40 GHz OFDM Ro-FSO transmission with mode division multiplexing," *Journal of the European Optical Society-Rapid publications*, vol. 9, 2014.
- [28] M. Krenn, J. Handsteiner, M. Fink, R. Fickler, R. Ursin, M. Malik, *et al.*, "Twisted Light Transmission over 143 kilometers," *arXiv preprint arXiv:1606.01811*, 2016.
- [29] M. Krenn, R. Fickler, M. Fink, J. Handsteiner, M. Malik, T. Scheidl, *et al.*, "Communication with spatially modulated light through turbulent air across Vienna," *New Journal of Physics*, vol. 16, p. 113028, 2014.
- [30] M. Krenn, J. Handsteiner, M. Fink, R. Fickler, and A. Zeilinger, "Twisted photon entanglement through turbulent air across Vienna," *Proceedings of the National Academy of Sciences*, vol. 112, pp. 14197-14201, 2015.
- [31] Y. Zhu, K. Zou, Z. Zheng, and F. Zhang, "1  $\lambda \times$  1.44 Tb/s free-space IM-DD transmission employing OAM multiplexing and PDM," *Optics express*, vol. 24, pp. 3967-3980, 2016.
- [32] Y. Zhao, J. Liu, J. Du, S. Li, Y. Luo, A. Wang, *et al.*, "Experimental Demonstration of 260-meter Security Free-Space Optical Data Transmission Using 16-QAM Carrying Orbital Angular Momentum (OAM) Beams Multiplexing," in *Optical Fiber Communication Conference*, 2016, p. Th1H. 3.
- [33] H. Zhang, N. Kavanagh, Z. Li, J. Zhao, N. Ye, Y. Chen, *et al.*, "100 Gbit/s WDM transmission at 2  $\mu\text{m}$ : transmission studies in both low-loss hollow core photonic bandgap fiber and solid core fiber," *Optics express*, vol. 23, pp. 4946-4951, 2015.
- [34] P. Kumar, A. K. Meher, S. Acharya, and P. S. Mund, "Novel design of PCF with zero dispersion with high birefringence," in *Electronics and Communication Systems (ICECS), 2015 2nd International Conference on*, 2015, pp. 1075-1077.

- [35] E. E. R. Vera, J. E. U. Restrepo, N. E. G. Cardona, and M. Varón, "Mode selective coupler based in a dual-core photonic crystal fiber with non-identical cores for spatial mode conversion," in *Latin America Optics and Photonics Conference*, 2016, p. LTu3C.1.
- [36] J. Wang, L. Pei, S. Weng, L. Wu, L. Huang, T. Ning, *et al.*, "A Tunable Polarization Beam Splitter Based on Magnetic Fluids-Filled Dual-Core Photonic Crystal Fiber," *IEEE Photonics Journal*, vol. 9, pp. 1-10, 2017.
- [37] A. Ghatak and K. Thyagarajan, *An introduction to fiber optics*: Cambridge university press, 1998.
- [38] R. Soft, " Photonics Component Design Suite, version 8.2," 2010.
- [39] I. I. Kim, B. McArthur, and E. J. Korevaar, "Comparison of laser beam propagation at 785 nm and 1550 nm in fog and haze for optical wireless communications," in *Information Technologies 2000*, 2001, pp. 26-37.
- [40] A. K. Majumdar, "Free-space laser communication performance in the atmospheric channel," *Journal of Optical and Fiber Communications Reports*, vol. 2, pp. 345-396, 2005.

**Dr. Sushank Chaudhary** has completed his PhD at Optical Computing and Technology Laboratory, UUM, Malaysia. He has published over 30 research papers in reputed international journals and conferences. During his PhD tenure, he was invited by Government College Engineering Ajmer, I.I.T Bhubaneswar, NIT Bhopal, SMVDU Jammu, SVNIT Surat and BHEL Hyderabad as a guest speaker to deliver lecture on advanced optical communication systems and training of Optiwaves software. Hailed from Himachal Pradesh, India, he was a senior research associate at GigaSoft India (Optiwave, Canada) before joining PhD. During his job, he was invited by more than 50 universities to give training on Optiwave software – OptiSystem, OptiFiber, OptiBPM, OptiGrating, OptiFDTD and OptiSpice software. He was also invited by various research organizations such as ISRO Ahmedabad, NSTL-DRDO Vishakhapatnam. He also received award of Born Navigator for his research paper from DRDO Hyderabad. He has obtained M.Tech in Electronics and Communication Engineering with specialization of Optics Communication from S.B.S.S.T.C, Ferozepur in 2012; B.Tech in Electronics and Communication Engineering from B.H.S.B.I.E.T, Lehragaga in 2010 and Diploma in Electronics and Communication Engineering from Govt. Polytechnic College, Rohroo in 2007. His main research interests are: Free Space Optics, Radio over Free Space Optics, Radio over Fiber, Integrated Optics, Multimode Transmissions, Hybrid Optical and Wireless Communication systems, Ultra dense wavelength division multiplexing, Inter-Satellite Communication Systems, Opto-Electrical Transmission systems and Advance Optical communication systems.

**Assoc. Prof. Dr. Angela Amphawan** received her PhD in optical communications engineering from University of Oxford, United Kingdom. She is currently Head of the Optical Computing and Technology Research Laboratory at School of Computing, Universiti Utara Malaysia and a Fulbright Research Fellow at Massachusetts Institute of Technology, USA. Due to her excellent standing in the optics community, she has been appointed to serve on the IEEE Nanotechnology Council and IEEE Sensors Council. She has won the Fulbright Award and the International Academic Award by the Deputy Prime Minister for her outstanding contribution. Her research has been funded by the Fulbright Foundation, Telekom Malaysia, German Academic Exchange and the Malaysian Ministry of Higher Education. She has been invited as a keynote speaker for the Fulbright-Malaysian Communications & Multimedia Commission Seminar (MCMC) Academic-Industrial Seminar, IEEE International Conference on Microwave and Photonics, International Conference on Communication and Computer Engineering and several others conferences. She has won two Best Paper Awards and several exhibition medals. She currently serves on the Editorial Board of International Journal of Electrical and Computer Engineering, International Journal of Informatics and Communication Technology, International Journal of Emerging Technology and Advanced Engineering, Applied Physics and Mathematics. She has also served as Publicity Co-chair for the IEEE Wireless Communications and Networking Conference International Conference (WCNC), Technical Committee for Electrical Engineering, Computer Science and Informatics, International Conference on Internet Applications, Protocols and Services and several other conferences.



