



DESIGN OF AN OPTICAL TOUCH SENSING
SYSTEM FOR A REMOTE MANIPULATOR

by

TOM G. STRICKLER, III

Submitted in Partial Fulfillment

of the Requirements for the

Degree of Master of Science

at the

MASSACHUSETTS INSTITUTE OF TECHNOLOGY

June, 1966

Signature of Author _____
Department of Mechanical Engineering

Certified By _____
Thesis Supervisor

Accepted by _____
Chairman, Departmental Committee
On Theses

TABLE OF CONTENTS

	<u>page</u>
ABSTRACT-----	1
ACKNOWLEDGEMENT-----	11
I. INTRODUCTION-----	1
II. PREVIOUS WORK-----	3
III. PROBLEM STATEMENT-----	8
IV. MOIRE TECHNIQUES-----	8
V. MODIFIED MOIRE TECHNIQUE-----	13
VI. REFLECTED GRIP TECHNIQUE-----	16
VII. THE OPTICAL TOUCH SENSING SYSTEM-----	18
VIII. SUGGESTIONS-----	26
BIBLIOGRAPHY-----	28

DESIGN OF AN OPTICAL TOUCH SENSING
SYSTEM FOR A REMOTE MANIPULATOR

by

TOM G. STRICKLER, III

Submitted to the Department of Mechanical Engineering
in partial fulfillment of the requirements for the Degree
of Master of Science.

ABSTRACT

Various methods of producing high contrast optical stress patterns are investigated for use with a coherent fiber bundle-television viewing system. The most successful method, which involves a fixed pattern whose reflection is viewed in a flexible mirror, is incorporated in the design and construction of an optical touch sensing system for a remote manipulator.

Thesis Supervisor: Thomas B. Sheridan
Title: Associate Professor of Mechanical Engineering

ACKNOWLEDGEMENT

I wish to express my gratitude to Professor Thomas B. Sheridan for his guidance and encouragement throughout the course of this work, and without whose help it would not have been possible.

I also wish to express my gratitude to Professor William R. Ferrell for his advice and assistance.

This thesis was supported in part by the National Aeronautics and Space Administration under contract NsG 107-61 and sponsored by the Division of Sponsored Research of M.I.T.

I. INTRODUCTION

In general the term remote manipulator refers to a machine which can grasp and maneuver objects by receiving commands from a human operator (or perhaps a computer) at some remote location. Remote manipulators are widely used to perform manual tasks which, were it not for unfavorable environmental factors such as radiation, would be performed directly by the human. In such cases the manipulator serves as a second, remote pair of hands for the operator.

For example, Figure 1 is a photograph of the AMF Model 8 manipulator used in this project. The handle to the right of the photograph is grasped by the operator, and movements of his hand are duplicated by the remote jaws or slave hand to the left. By squeezing the rings at the handle, the operator can close the jaws for grasping. In this case commands from the operator are carried by direct mechanical linkages. The degrees of freedom provided are sufficient to allow the jaws to be maneuvered into almost any desired position. In spite of this, with the AMF manipulator as with remote manipulators in general, manipulative tasks are tedious and difficult. This is partly due to mechanical inertia and the fact that the jaws provide in effect only two fingers for grasping. More interesting for present consideration, however, is the lack of tactile feedback between the remote jaws and the operator. The other types of feedback, involving motion, position, force, and vision, are sufficient to enable the operator to form an identity between the slave hand and his own. Obviously, if the manipulator were endowed with a sense of touch the identity would be more

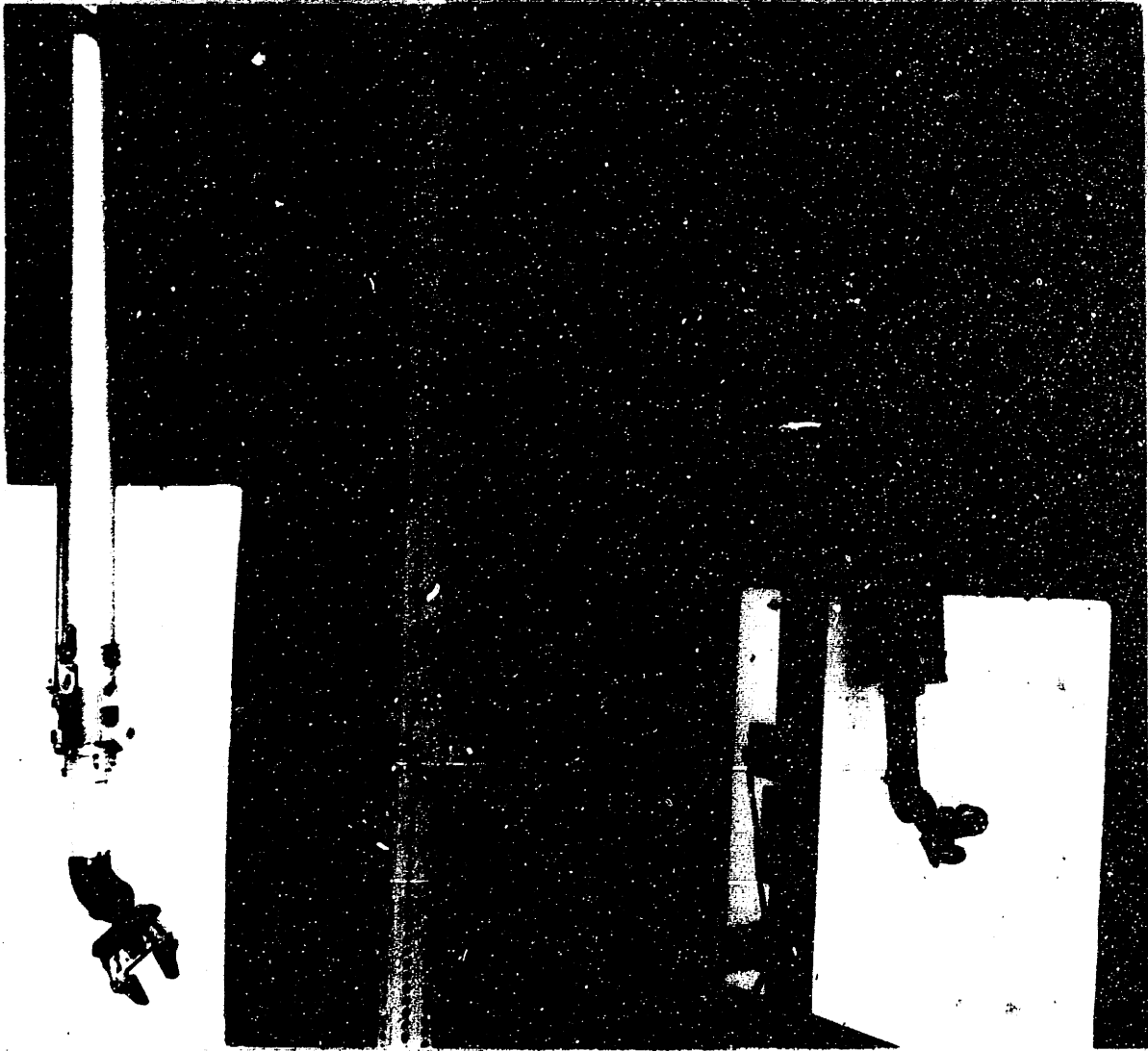

Figure 1. The AMF Model 8 manipulator.

complete and manipulative tasks would be less difficult. In the ideal case this sense of touch would involve transmitting pressure patterns encountered by the manipulator jaws directly to the fingers of the operator, but due to space limitations this is not possible, and a substitute sense of touch has been sought.

Figure 2 is a schematic representation of one of the more promising approaches to the problem. It involves the visual interpretation of optical stress patterns generated at the remote jaws. The pattern generator, which forms the bearing (sensing) surface of one of the jaws, is made of some material which changes optically when stressed so that when pressed against an object in grasping, regions of contact are distinguished by a mechanism to be described in detail below. These optical changes are viewed by the operator through a visual system consisting of a television camera and monitor, and a coherent fiber bundle. The fiber bundle transmits the picture from the pattern generator to the camera, and provides the flexibility necessary to follow the maneuverings of the slave hand.

II. PREVIOUS WORK

To determine the effectiveness of the visual approach to tactile feedback, J.J. Kappl (1) tested subjects using optical stress patterns as a substitute sense of touch. For his experiments Kappl used a photoelastic material (polyurethane rubber) as a pattern generator. The arrangement, similar to a polariscope, is shown in Figure 3. The polyurethane is more or less transparent and does not normally affect

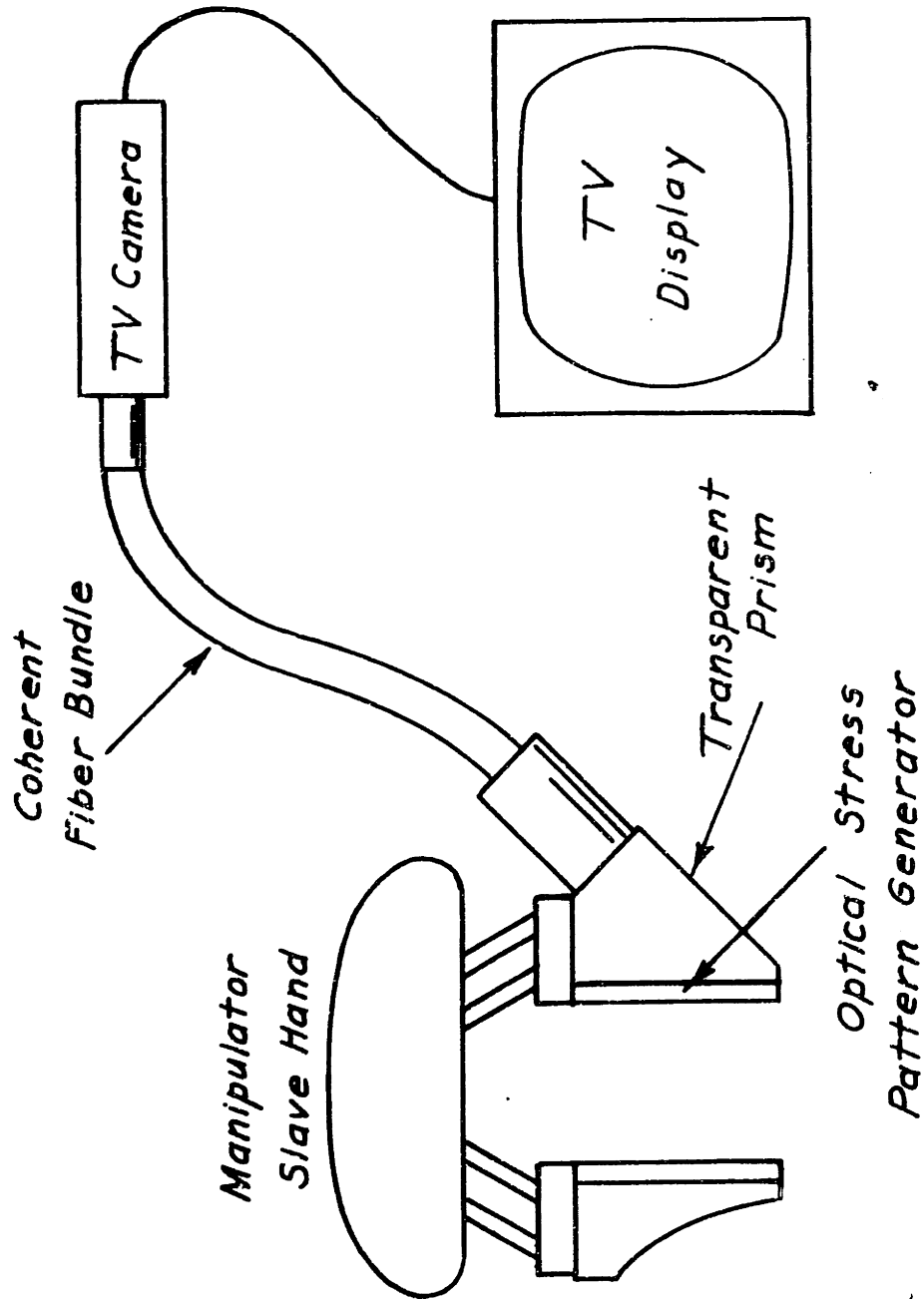

Figure 2. An optical touch sensing system.

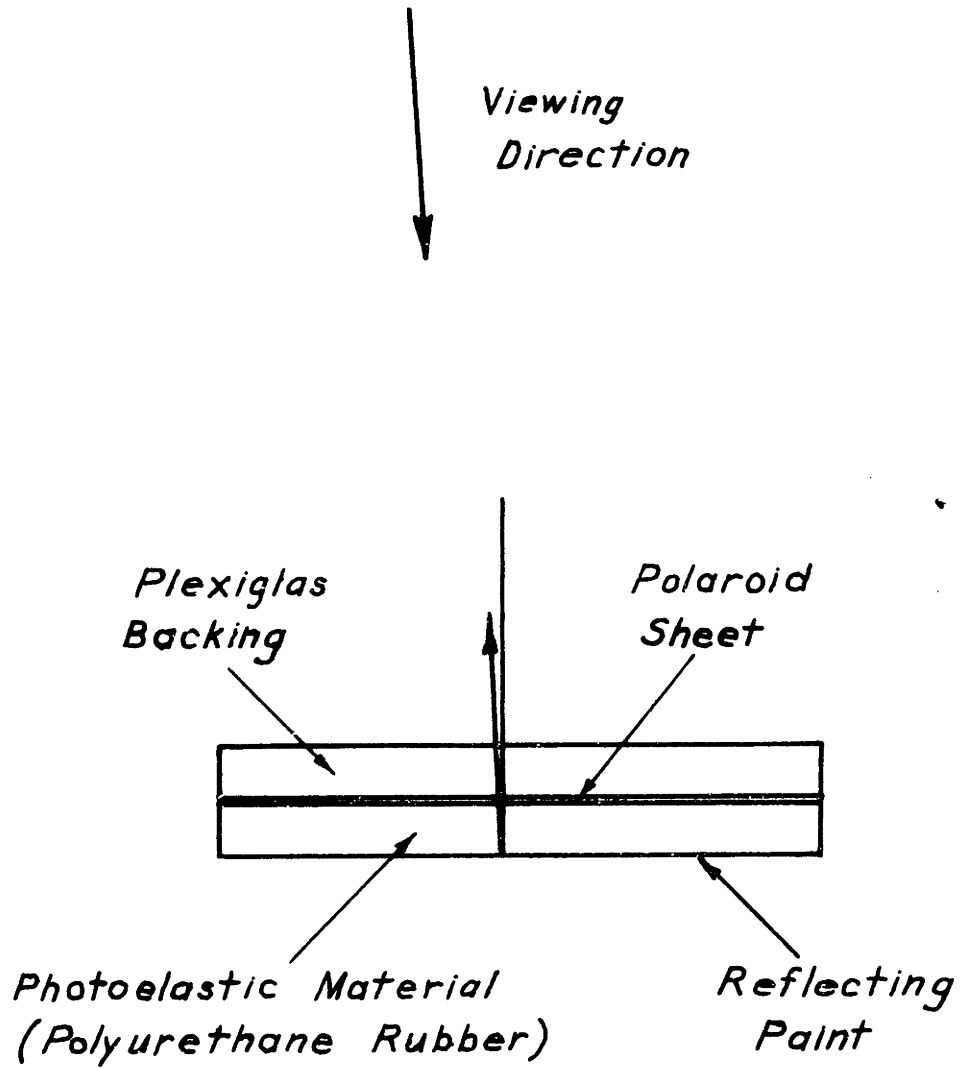

Figure 3. Cross section of a photoelastic pattern generator.

light passing through it. Light, therefore, can pass through the polaroid sheet, bounce back in phase and pass on through the polaroid sheet again. When strained, however, the polyurethane polarizes light passing through it and produces a phase shift proportional to the strain. Interference occurs, then, at different levels of strain, and when viewed from the direction shown, dark bands are seen along lines of constant strain in the polyurethane. Since the amount of phase shift is also proportional to the wavelength of the light, white light gives colored bands or fringes. Hence, in a touching operation, the regions of contact are outlined by these colored fringes.

Comparing a 4 inch square of the photoelastic sandwich assembly with the human palm, Kappl found that the two performed about equally well in identifying small objects. The real test of course comes when the photoelastic pattern generator is actually used on the remote manipulator with the TV and fiber bundle.

Figure 4 shows a manipulator grip designed by a 2.671 project group (2) to fit the AMF manipulator. The pattern generator is the same type used by Kappl. The polished plexiglas prism allows one surface to act as a mirror between the fiber bundle and the pattern generator (by total internal reflection) and at the same time as a window for illumination. This enables convenient positioning of the fiber bundle and keeps the grip compact.

It was found, however, that although the prism itself worked well enough the patterns generated by the photoelastic device lacked the brightness and contrast necessary to produce a visible display using both the fiber bundle and TV (see Figure 2).

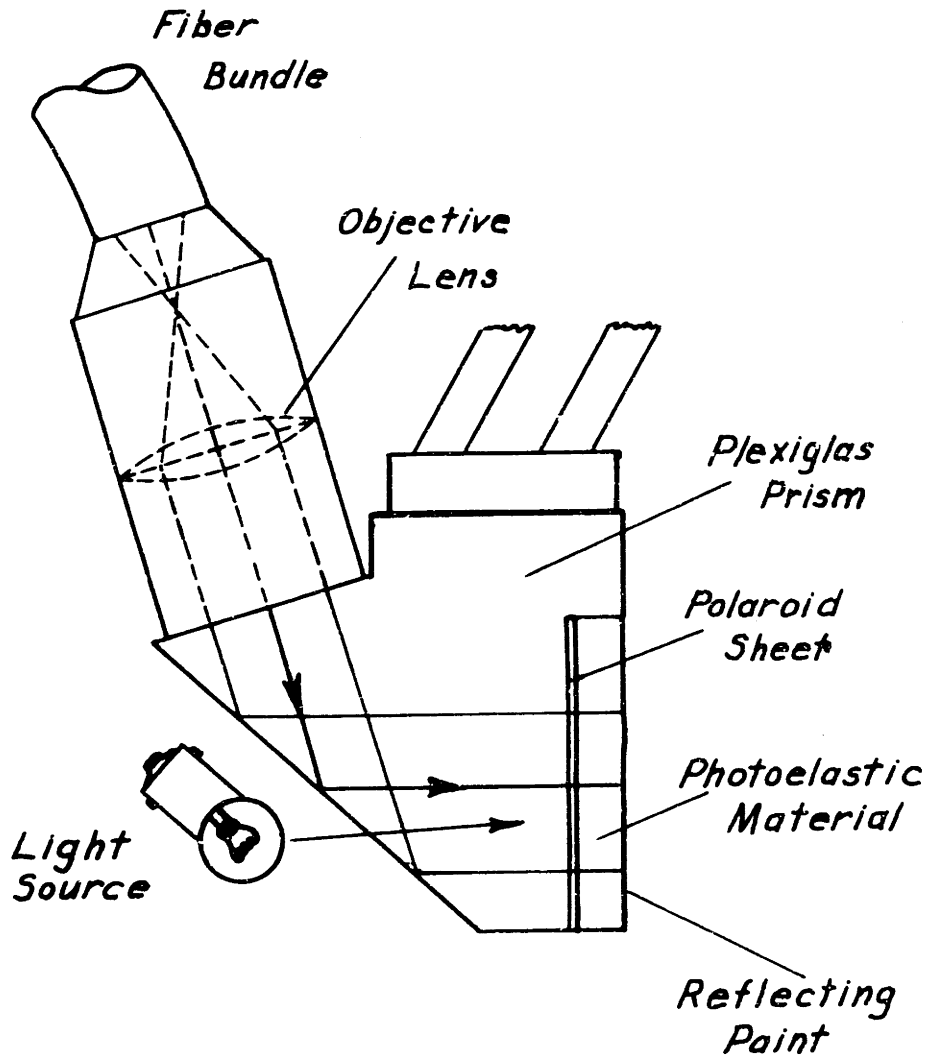

Figure 4. Manipulator grip with photoelastic pattern generator.

III. PROBLEM STATEMENT

The problem considered in this project was that of fitting a remote manipulator with a working optical touch sensing system, preferably using equipment readily available to the Man Machine Systems Laboratory of the Mechanical Engineering Department. This equipment included the AMF Model 8 manipulator, an EMI TV camera and control unit, a standard 21 inch TV monitor, and a Bausch & Lomb coherent fiber bundle. The main problem, then, was to develop a new type of optical stress pattern generator with improved contrast and brightness.

IV. MOIRE TECHNIQUES

The first attempt at an improved pattern generator involved the use of moire techniques. Such techniques are sometimes used in stress analysis (3). Basically, a moire pattern generator consists of a grid or array (such as parallel lines, concentric circles, or dots) printed on a white background. Over this is laid another (usually identical) array which is printed on some transparent material. If one array is shifted, rotated or deformed relative to the other, a moire pattern results due to apparent intersections of the two grids (references 3 and 4 give a more detailed treatment of this phenomenon). Figure 5 shows a moire pattern developed by two arrays of concentric circles, where one array is displaced slightly relative to the other.

Figure 6 shows a moire pattern generator applied to a manipulator grip. The plexiglas prism serves the same purpose as the one in Figure 4.



Figure 5. Moire pattern produced with arrays of concentric circles.

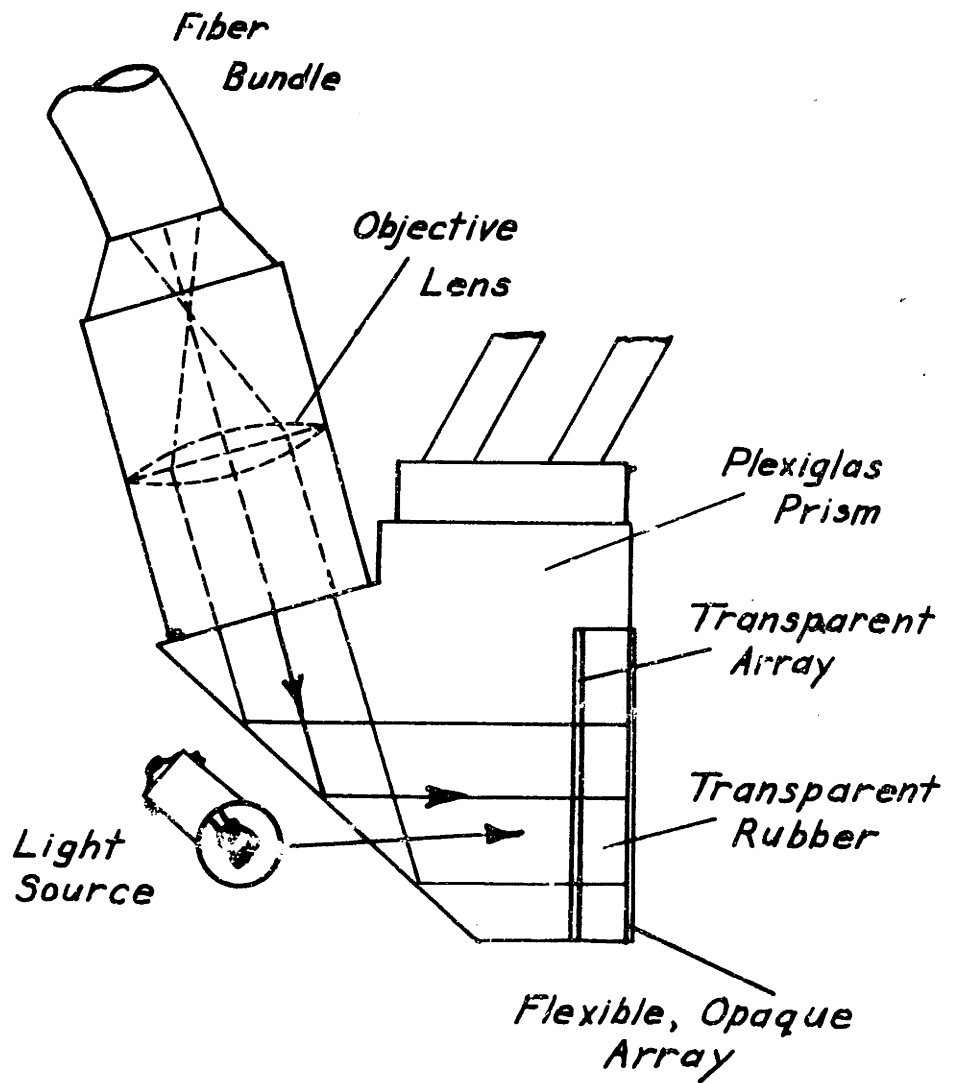

Figure 6. Manipulator grip with moiré pattern generator.

The transparent array is rigid, but the opaque array is flexible and is mounted on transparent rubber. Therefore when an object is touched by the manipulator grip the opaque array is free to deform and, in principle at least, moire fringes similar to those in Figure 5 result.

For experimental testing an array of dots was printed on sheet rubber coated with white rubber paint (Hypalon, by Du Pont). Printing was accomplished photographically using silk screening emulsion mixed with black ink. A 50% (i.e., half clear, half black) half-tone photographic negative was used both to produce the dots and as the transparent array. The density of the dots was about 150/inch.

An electronic potting compound known as Sylgard 184 (by Dow Corning) was used as the transparent rubber. This compound is water-clear, has roughly the same elasticity as a rubber band, is reasonably tough, and is easily mixed and cured.

When the moire pattern generator was assembled it was found that contrast and brightness were somewhat better than with the photoelastic pattern generator. This was due to the use of black-on-white array, and to the fact that the polyurethane rubber (which has the color of maple syrup) was not needed. Really good contrast and brightness were prevented by the fact that the moire fringes must be viewed through the transparent array. The lighter portions of the fringes were at best only medium gray (see Figure 5).

Figure 7 illustrates another problem with the moire pattern generator - that of focusing the fringes onto the fiber bundle. For maximum brightness the lens used for this focusing must be relatively large and, due to space limitations, relatively close to the pattern generator. As Figure 7

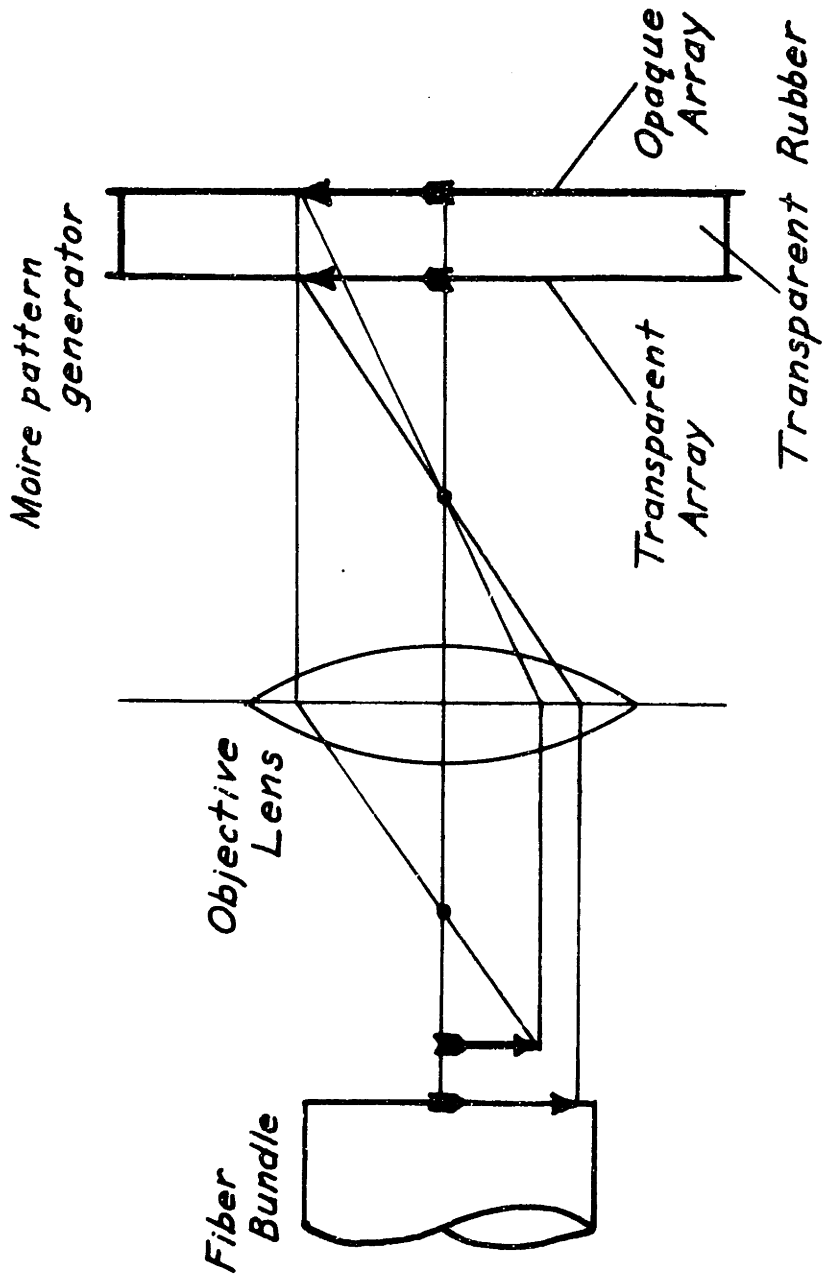

Figure 7. Schematic illustration of the focusing problem with the moire pattern generator.

illustrates, it was found impossible to focus sharply on both the opaque and transparent arrays at the same time, and the moire fringes were seriously degraded.

Finally, there was a problem of sensitivity. Referring again to Figure 7, it can be seen that moire fringes can result only if the flexible array is distorted in a direction perpendicular to the line of sight. Since in a grasping or touching operation most of the forces are applied parallel to the line of sight, the moire pattern generator can react to only a small fraction of the total distortion.

It was finally decided that, due to the above problems, the moire pattern generator represented little or no improvement over the photoelastic material, and it was therefore abandoned.

V. MODIFIED MOIRE TECHNIQUE

Figures 8 and 9 show a modification of the moire pattern generator designed to improve sensitivity. Here, the flexible opaque array has been replaced by a flexible mirror so that the transparent array acts with its reflection to produce moire fringes. The advantage of this arrangement comes from the fact that distortions of the mirror produce curved surfaces which reflect light at an angle to the line of sight. The optical leverage which results causes small distortions in the mirror to produce large distortions in the reflection of the array. This process is discussed more fully in the next section.

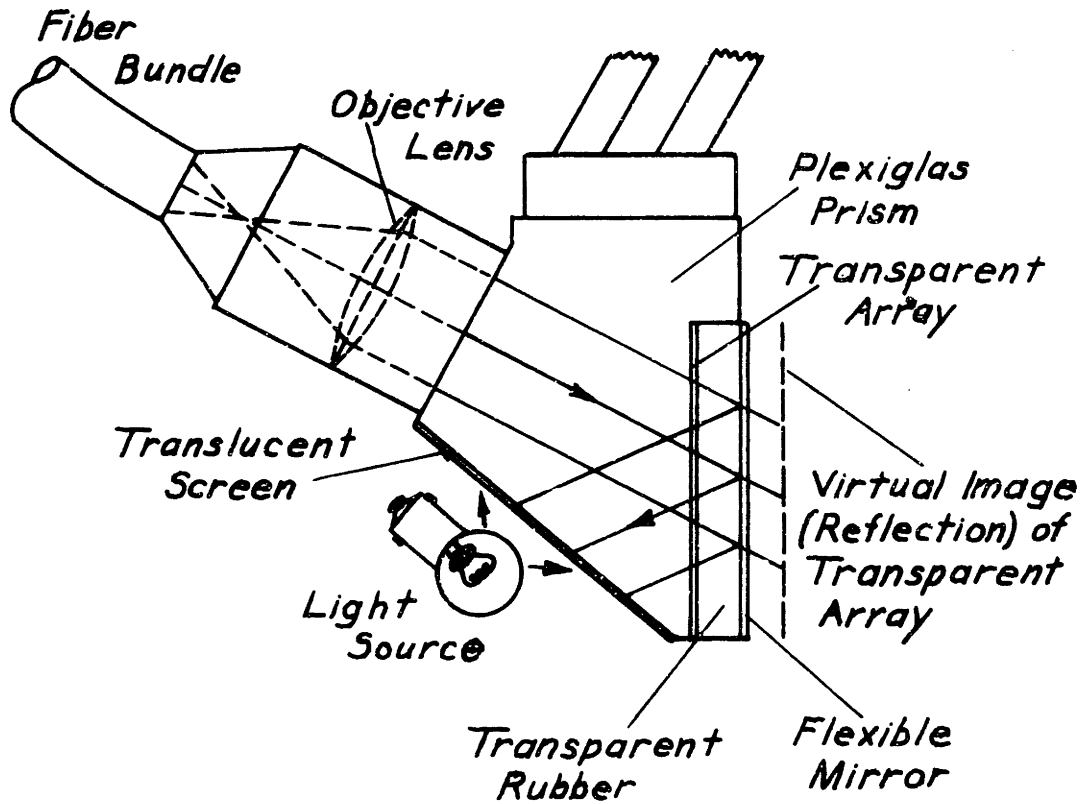

Figure 8. Manipulator grip with modified moiré pattern generator.

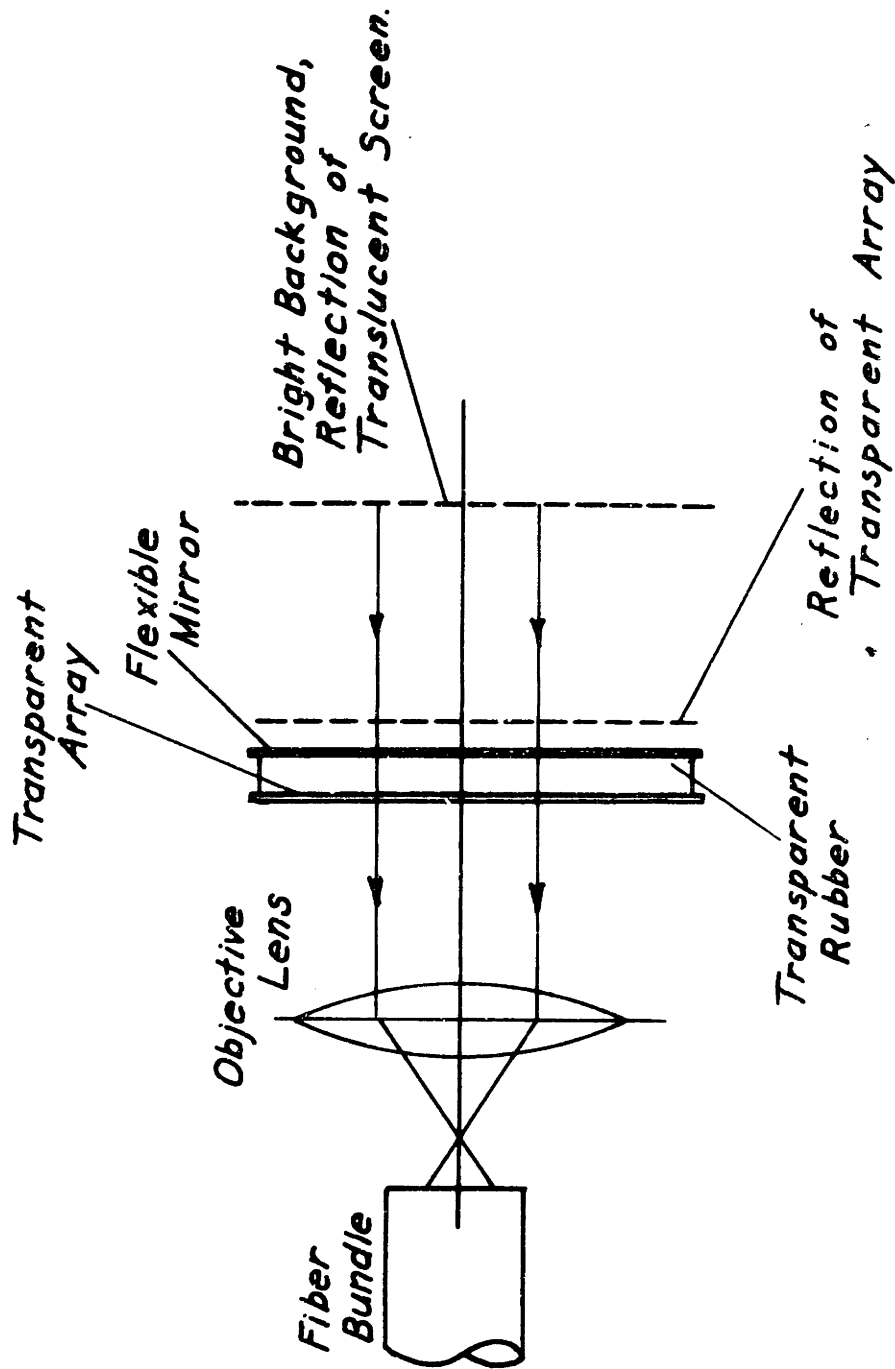

Figure 9. Simplified diagram of the modified moire pattern generator. The transparent array acts with its reflection to produce moire fringes.

For experimentation, half-silvered plastic film (from Edmund Scientific Co.) was used as the flexible mirror. The prism used with the previous pattern generators was discarded since, because of the mirror, the fiber bundle could see only the reflection of its own objective lens behind the moire patterns. To allow adequate background illumination, the arrangement of Figure 8 was used. In this case the prism serves no purpose other than to support the various components. The fiber bundle views the pattern generator directly, and the illuminated translucent screen provides a bright background for the moire fringes.

The sensitivity of the modified moire pattern generator was found to be quite acceptable, but again the contrast and brightness of the fringes were degraded by viewing through the transparent array. It was apparent, however, that although insufficient to produce a display with the TV-fiber bundle combination, the contrast and brightness were considerably improved by use of the illuminated translucent screen as a background.

The problem of focusing on both arrays at once was the same as with the unmodified moire pattern generator, and the modified version was also abandoned.

VI. REFLECTED GRID TECHNIQUE

Figure 10 shows a pattern generator which, because of its simplicity, eliminates the problems encountered with the moire techniques.

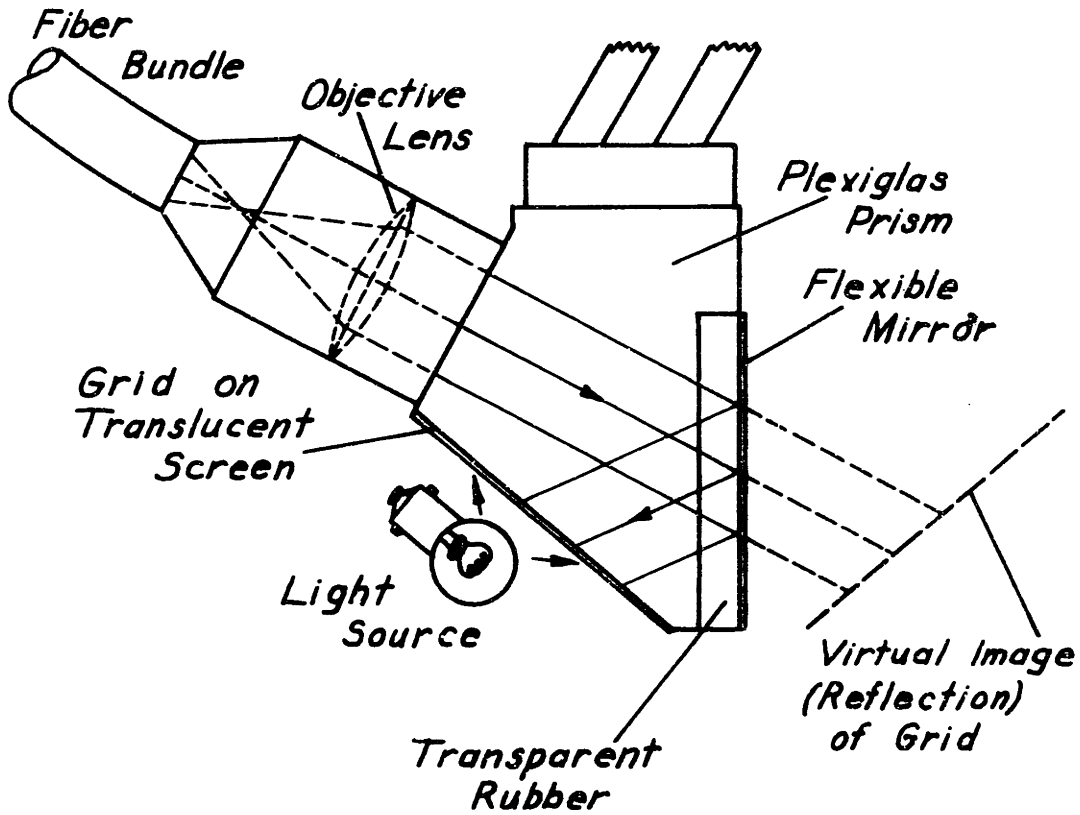

Figure 10. Manipulator grip with reflected grid pattern generator.

It consists of a single array or grid whose reflection is viewed in the flexible mirror. The grid is coarse enough for the individual components (squares, dots, lines, etc) to be distinguished, so that distortions of the grid's reflection are easily seen as discontinuities in the symmetry of the array. Since the distance from the mirror to the grid is relatively large, the grid's reflection is highly sensitive to distortions in the mirror, due to the optical leverage mentioned previously.

Since only one array is necessary there is no problem in focusing and no reduction in contrast and brightness from viewing through a transparent array. If the grid is printed on translucent material and illuminated as shown in Figure 10, very high contrast and brightness can be obtained with a modest light source.

Tests with the reflected grid pattern generator in combination with the TV and fiber bundle showed that a somewhat feeble but definitely visible display could be obtained, so an optical touch sensing system using this device was built.

VII. THE OPTICAL TOUCH SENSING SYSTEM

The plexiglas grip of Figure 11 was designed and built to fit the AMF manipulator. It supports the fiber bundle, light source, and the pattern generator. The EMI TV camera was mounted on the non-sliding section of the manipulator arm. Figure 12 is a photograph of this arrangement.

Plexiglas Tube, 1/4" od, 1 id,
Holds Fiber Bundle.

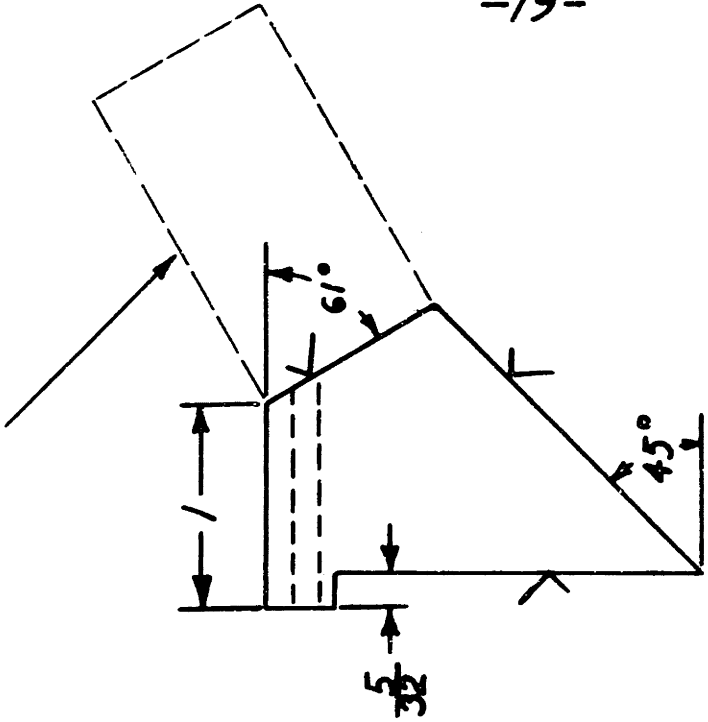

Material: Plexiglas
Surfaces Optically Smooth

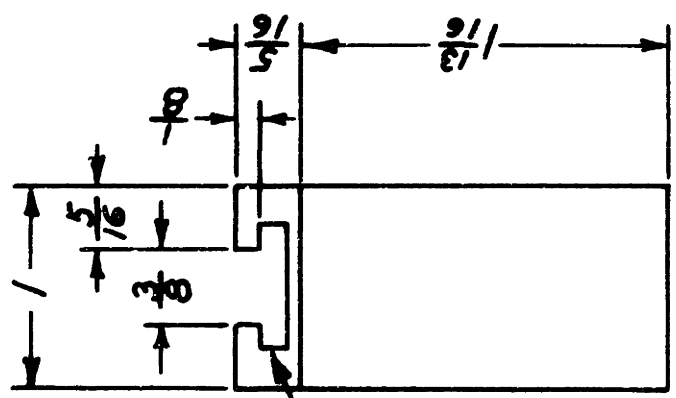

Keyway $\frac{5}{8} \times \frac{1}{8}$

Figure II. Construction details of prism for the reflected grid pattern generator.

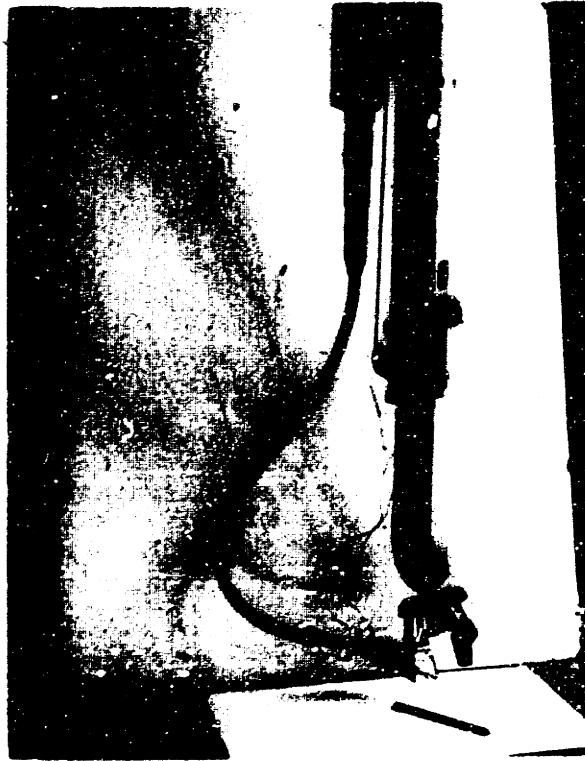

Figure 12. Above: Slave manipulator arm with TV camera, fiber optics, and reflected grid pattern generator. Below: Close-up of slave hand and pattern generator.



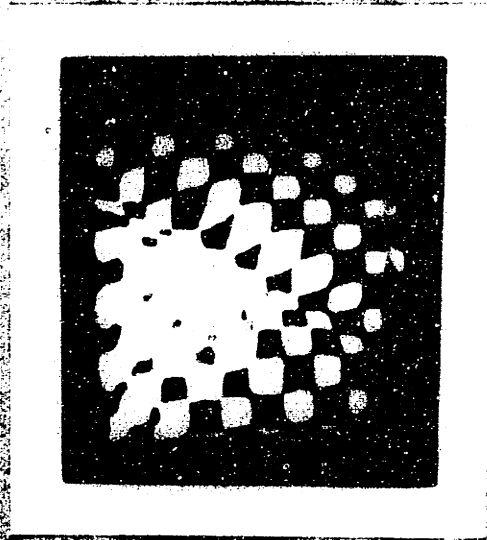

Figure 1. Grid pattern produced in distorted grid pattern

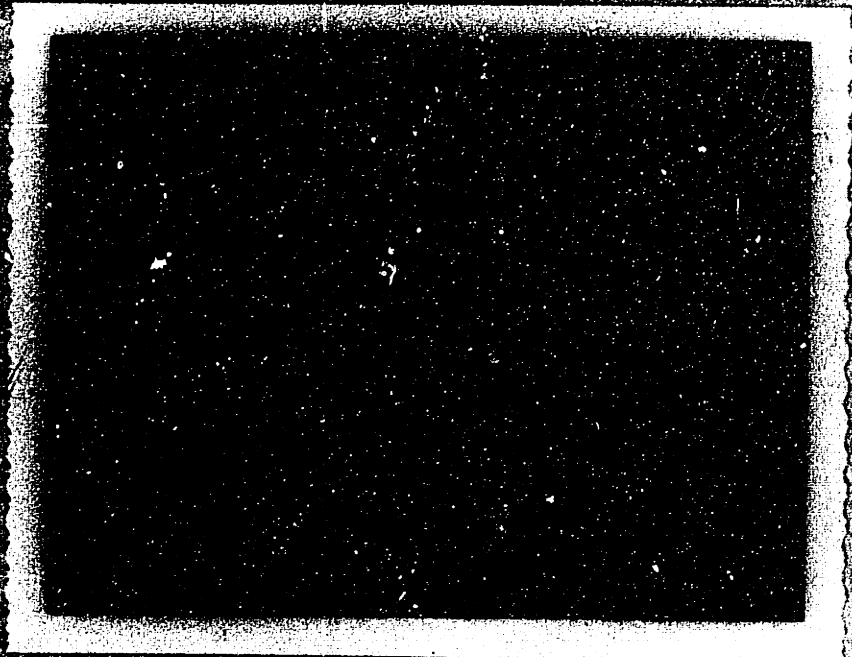

Figure 2. Grid pattern showing distorted grid pattern produced using the

The general character of the patterns obtained with the reflected grid technique is indicated in Figure 13, which is a photograph of the distortion in a checkerboard array produced by grasping a pencil. The picture was taken by holding the lens of the camera against the eyepiece of the fiber bundle.

The TV monitor screen proved difficult to photograph, but Figure 14, which registers only the central portion of the screen, indicates roughly the contrast of the final display.

The evaluation of the system of Figure 12 as a substitute sense of touch has been left for others, but Kappl's work indicates that the identification of curved surfaces generated in a touching operation is an important parameter in optical touch sensing. Figure 15 illustrates the relationship between grid distortions and mirror curvature in the reflected grid pattern generator. In Figure 15(a), point b on the grid is seen reflected in point a on the mirror. When an object is pressed against the mirror as in Figure 15(b), the resulting curved surfaces cause the mirror at point a to rotate through an angle θ . Point b' is now seen reflected in point a. For small angles, the distance between b and b' is given by

$$bb' = 2\theta L$$

where L is the distance between the mirror and the grid. The curvatures of the mirror, then, can be determined from the distance which points on the grid appear to move.

If a tangential force is applied to a grasped or touched object

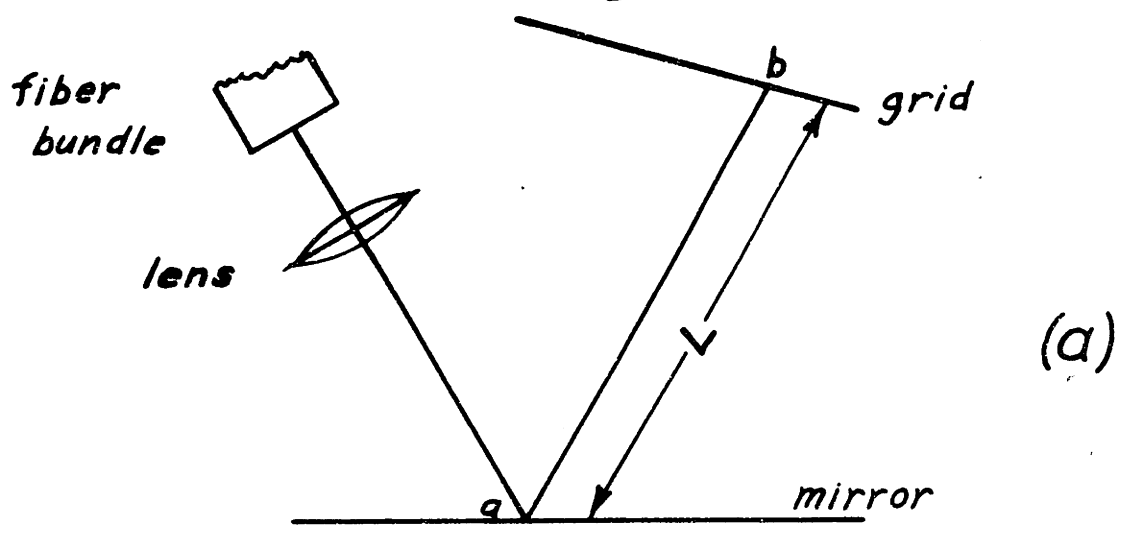

(a)

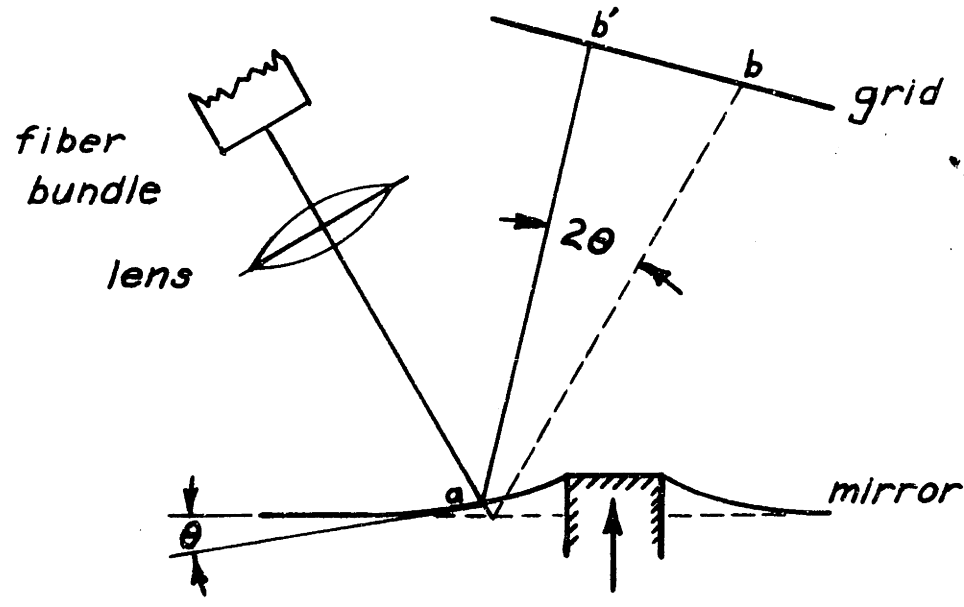

(b)

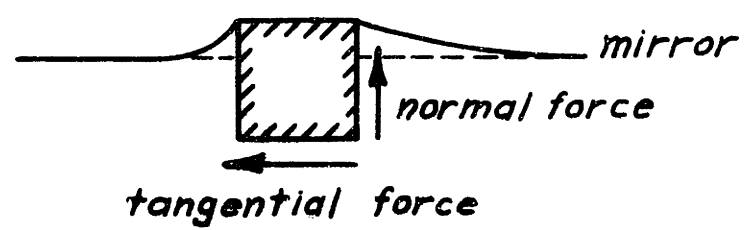

(c)

Figure 15. Illustration of the relationship between mirror curvature and grid distortions in the reflected grid pattern generator.

as in Figure 15(c), sharper curvatures in the mirror (and consequently greater distortions in the grid) occur at the edge toward which the tangential force is directed.

For demonstration purposes, a simple manipulative task was arranged. The objective of the task was for the operator (the author) to use the manipulator to find and transfer a cylindrical peg from one hole to another without viewing the task directly. The diameter of the peg was 1 inch. The two holes were 1-1/16 inches in diameter and were separated by a distance of 1 foot. (See Figure 16).

To make the task managable, two reference marks were placed under the handle (i.e., the part grasped by the operator) of the manipulator, so that when the handle was positioned over a reference mark the slave hand was positioned over the corresponding hole at the task site. The method of operation involved moving to the location of the first hole, securing a grip on the peg, moving it to the location of the second hole, and probing against the board with the peg until the hole was found.

Several runs were made with and without the aid of the optical touch sensing system. It was found that if the task was completed without mishap, use of the touch sensing system did not significantly reduce the time required for completion. However, it was also found that the touch sensing system was of considerable value in preventing and diagnosing trouble. For example, about 20% of the runs without the sensing system ended in failure because the peg was grasped too near the edge of the grips and was dropped, either in transit or in probing. With the touch sensing system a secure grip could always be assured before the peg was removed from the first hole.

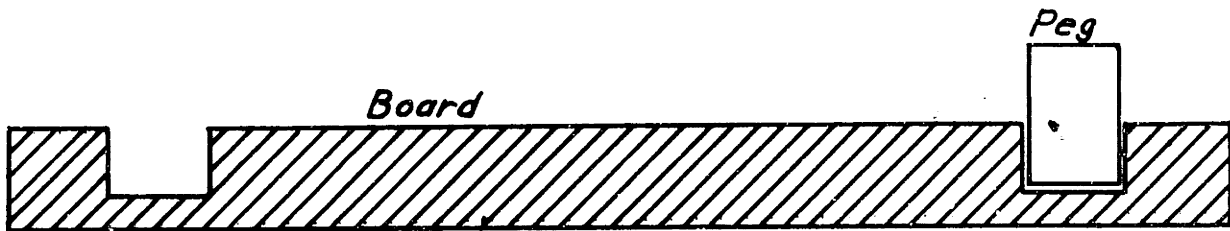

Figure 16. Manipulative task layout.

Also, because of the rather close tolerances between the peg and the holes, it was necessary to maintain the peg in a nearly vertical position. If the peg became disoriented with respect to the grips, considerable time could be spent probing with the peg in a position such that it could never fit into the hole. Such disorientations were immediately visible with the touch sensing system, and probing could be discontinued until the situation was corrected.

VIII. SUGGESTIONS

As pointed out earlier, the touch sensing system of this project was designed for use with equipment readily available to the Man Machine Systems Laboratory. Experiments with a fiber bundle-TV system from the M.I.T. Audio Visual Service showed that equipment which is superior with respect to resolution and contrast gives vastly superior displays. For future optical touch sensing systems, then, it may be worthwhile trying to improve the other pattern generators discarded in this project. Some of the numerous suggestions made by interested people are discussed below.

- 1) Use of a monochromatic light source with the photoelastic pattern generator (Figure 4) would eliminate coloration of the fringes which degrade contrast. This still leaves the polaroid sheet, the colored polyurethane, and the reflective paint to hamper brightness and contrast. Use of a flexible mirror rather than the "silver" (actually rather gray) paint might help, but a preliminary experiment did not show this. In this case the fact that the distorted mirror reflects light

away at an angle degrades the fringe patterns. A more transparent photoelastic material, if it could be found, would help. (The Sylgard 184 gave some very faint fringes).

The photoelastic pattern generator is somewhat similar to the unmodified moire device in that it is less sensitive to pressure applied parallel to the line of sight.

2) For the unmodified moire pattern generator, the focusing problem (Figure 7) could perhaps be corrected using a more sophisticated lens system, such as a collimating lens, or by introducing the transparent array at a point analogous to the cross-hairs in a telescopic rifle sight. This leaves the problem of sensitivity.

3) For the more sensitive modified moire pattern generator (Figure 8) the focusing problem could be eliminated simply by reducing the diameter of the lens until the geometry of Figure 7 is acceptable. If sufficient brightness and contrast remain, this should be a workable system.

BIBLIOGRAPHY

1. Kappl, J.J., A Sense of Touch for a Mechanical Hand, S.M. Thesis, M.I.T., August, 1963 (unpublished).
2. Hardin, P., Heinemann, P. and Uscowicz, T., Instrumentation of A Remote Manipulator with a Stress Optical Touch Transducer, 2.671 Experimental Engineering Term Project Report, M.I.T., May, 1964 (unpublished).
3. Dally, J.W. and Riley, W.F., "Experimental Stress Analysis with the Moire Fringe Method", Product Engineering, May 24, 1964, Vol. 36, No. 11.
4. Strong, C.L., "The Amateur Scientist", Scientific American, November, 1964, Vol. 211, No. 5.