

## MIT Open Access Articles

*High-Power Fuel Cell Systems Fueled by Recycled Aluminum*

The MIT Faculty has made this article openly available. **Please share** how this access benefits you. Your story matters.

**Citation:** Godart, Peter, Fischman, Jason and Hart, Douglas. 2019. "High-Power Fuel Cell Systems Fueled by Recycled Aluminum." ASME International Mechanical Engineering Congress and Exposition, Proceedings (IMECE), 6.

**As Published:** 10.1115/imece2019-10478

**Publisher:** American Society of Mechanical Engineers

**Persistent URL:** <https://hdl.handle.net/1721.1/138104>

**Version:** Final published version: final published article, as it appeared in a journal, conference proceedings, or other formally published context

**Terms of Use:** Article is made available in accordance with the publisher's policy and may be subject to US copyright law. Please refer to the publisher's site for terms of use.



## HIGH-POWER FUEL CELL SYSTEMS FUELED BY RECYCLED ALUMINUM

**Peter Godart\***

Mechanical Engineering  
 Massachusetts Institute of Technology  
 Cambridge, MA 20139  
 Email: ptgodart@mit.edu

**Jason Fischman**

Mechanical Engineering  
 Massachusetts Institute of Technology  
 Cambridge, MA 20139  
 Email: jfischma@mit.edu

**Douglas Hart**

Mechanical Engineering  
 Massachusetts Institute of Technology  
 Cambridge, MA 20139  
 Email: dphart@mit.edu

### ABSTRACT

*Presented here is a novel system that uses an aluminum-based fuel to continuously produce electrical power at the kW scale via a hydrogen fuel cell. This fuel has an energy density of 23.3 kWh/L and can be produced from abundant scrap aluminum via a minimal surface treatment of gallium and indium. These additional metals, which in total comprise 2.5% of the fuel's mass, permeate the grain boundary network of the aluminum and disrupt its oxide layer, thereby enabling the fuel to react exothermically with water to produce hydrogen gas and aluminum oxyhydroxide, an inert and valuable byproduct. To generate electrical power using this fuel, the aluminum-water reaction is controlled via water input to a reaction vessel in order to produce a constant flow of hydrogen, which is then consumed in a fuel cell to produce electricity. As validation of this power system architecture, we present the design and implementation of two example systems that successfully demonstrate this approach. The first is a 3 kW emergency power supply and the second is a 10 kW power system integrated into a BWM i3 electric vehicle.*

### 1 INTRODUCTION

With double the energy density of gasoline and high abundance, scrap aluminum has potential as a viable fuel source for supplementing or altogether replacing fossil fuels in many applications. Recently developed methods for extracting the embodied chemical energy of aluminum allow it to be used for power generation in circumstances where space is constrained and en-

ergy density is key or where scrap aluminum is abundant and cheap.

When exposed to air or water, an oxide layer forms immediately on the surface of aluminum, making it functionally inert and unreactive. Several methods have been developed to bypass this surface oxide layer, such as ball milling aluminum into combustible powders [1] [8], alloying it with rare metals [11], and eroding it with strong acids [7]. The combustion hazards of aluminum powders, the high cost of alloying metals, and the safety concerns of working with strong acids have, however, kept aluminum fuel from being implemented in commercial power systems. In recent years new methods have been developed to make the production of aluminum fuels significantly safer and lower cost. The development of aluminum fuels that use only small amounts (2-5%) of alloying metals [9], or that use weak acids and bases for erosion [6], have contributed to pushing aluminum fuel into the spotlight as a high energy density power source. Using these methods aluminum can be reacted exothermically with water, producing hydrogen and aluminum oxyhydroxide via Eq. 1.

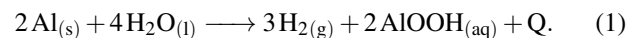

This reaction releases the internal chemical energy of aluminum (859 kJ/mol Al) as a mix of thermal energy and chemical potential energy of hydrogen in approximately equal proportions [4]. With the development of safer, cheaper, aluminum fuel production methods, this paper outlines the design and implementation of high-powered aluminum fueled electric gener-

\*Address all correspondence to this author.

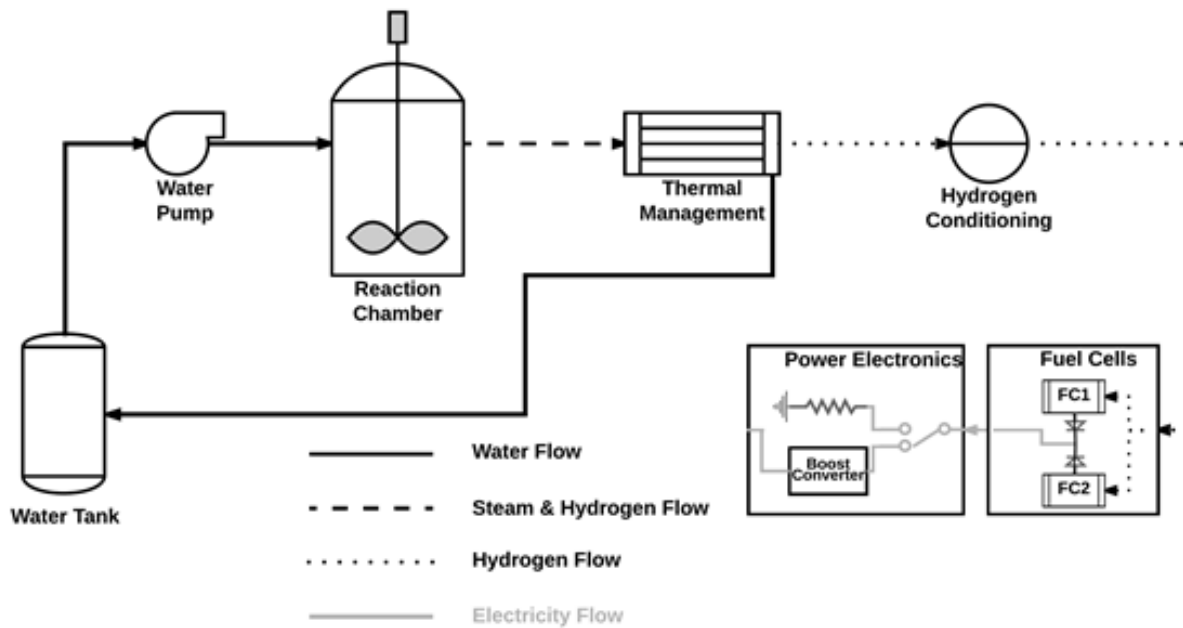

FIGURE 1. Block diagram system overview for aluminum fueled generators.

ators. These power systems produce electricity via highly efficient hydrogen fuel cells, allowing them to operate silently and with a balance of plant of comparable mass and volume to that required for the equivalent gasoline and diesel systems. Additionally, the reaction of aluminum with water produces no greenhouse gasses or toxic emissions, making these generators usable indoors without concern for carbon monoxide poisoning as is the case with standard gasoline and diesel generators. Finally, the systems presented here were powered using aluminum fuel treated via the Slocum method [10], which has been shown to produce fuel with a shelf life of several years. This storage capability is significantly longer than that of gasoline and diesel fuel which is highly advantageous for applications as emergency generators where use is infrequent and often unanticipated.

## 2 POWER SYSTEM OVERVIEW

To demonstrate the effectiveness of this aluminum fuel, two power systems were designed and built. The first is a 3 kW emergency power generator, and the second is a 10 kW power system integrated into a BMW i3 electric vehicle. The 3 kW and 10 kW generators each operate using the same strategy and high-level system topology as shown in Fig. 1. In both systems, aluminum is reacted with water in a batch reaction chamber. This reaction produces hydrogen gas which is fed into a PEM fuel cell to generate electricity, which supplies power to charge a battery bank. In the case of the 10 kW BMW system, this electricity is then run

through a boost-converter and used to directly charge the internal batteries of the electric vehicle. The thermal energy released by the reaction in either system is dissipated across a radiator and simply amounts to waste heat within the generators.

The power generation process begins with the addition of water into a reaction chamber filled with the activated aluminum fuel. This water then initiates an aluminum-water reaction which produces hydrogen gas as well as thermal energy that vaporizes excess water. The output hydrogen from this reaction must then be cooled and purified of steam and other gasses before it can be used in a PEM fuel cell. This purification is accomplished through a series of heat exchangers and gas purifiers where the steam is condensed, and residual water vapor and oxygen is removed from the hydrogen gas. During this process the steam is recovered and recycled into the system's on-board water tank. Once suitably purified, the hydrogen gas is finally directed into a PEM fuel cell, which converts the chemical energy stored in the hydrogen to electricity at an efficiency of roughly 40%. The output of the fuel cell is pure water, which can be fed back into the reactor to further conserve water consumption in this process.

## 3 APPLICATIONS

With the general power system layout developed and tested in a small-scale, 100 W configuration [10], two target applications were pursued as full-scale technology demonstrations. First, a 3 kW (nominal) power supply was developed as a drop-

in replacement for an equivalent diesel-fueled emergency generator. Second, a similar 10 kW power system was integrated directly into a BMW i3 electric vehicle in an effort to replace the gasoline-fueled range extender that recharges the main vehicle battery pack while driving.

### 3.1 3 kW EMERGENCY POWER SUPPLY

The expressed goal of the activated aluminum fuel power supply was to reduce the total system energy density (energy per unit volume) of the state-of-the-art power generators in order to develop a system that could be more efficiently stored for disaster preparedness or shipped to remote locations. To this end, a power system that leverages the high energy density of aluminum was developed. This power system consists of two separate modules: a reactor module as shown in Fig. 2 and a power conditioning and energy storage module as shown in Fig. 8. The electrical output of the fuel cell in the reactor module connects directly to the power conditioning module. The design details of each module are presented here.

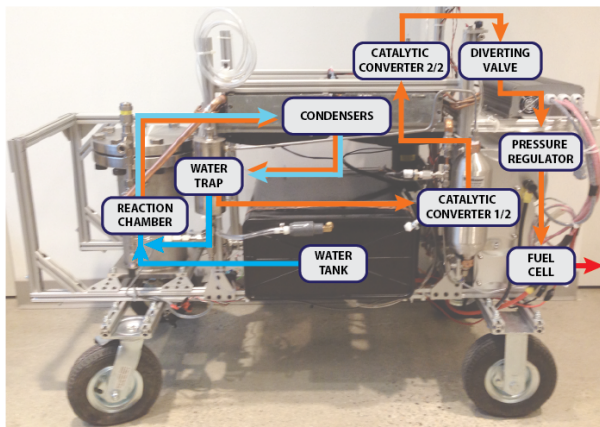

**FIGURE 2.** Total system layout for the 3 kW emergency power supply.

**3.1.1 REACTION SYSTEM** In order to produce 3 kW of electricity, the PEM fuel cell used in this power system requires a hydrogen supply rate of 40 L/min. From the stoichiometry shown in Eq. 1, it is therefore necessary to run the aluminum-water reaction at 30 g Al/min. To meet this required reaction rate, water must continuously reach the activated aluminum fuel at flow rate of 40 mL/min. For design simplicity, the reaction system utilizes a single batch reactor, which contains enough fuel

for an hour of operation (1.8 kg). In operation, activated aluminum fuel pellets are placed inside the chamber in an internal mesh basket to contain the waste AlOOH reaction product. The lid to the chamber is sealed, and water is pumped into the bottom of the chamber from the primary water line using a diaphragm pump. The reaction proceeds to produce hydrogen gas, AlOOH, and heat. The AlOOH waste product collects in the chamber's inner mesh lining and is emptied at the end of the cycle. At full power, the heat released from the exothermic reaction boils off 75% of the water entering the chamber, thereby removing this heat from the chamber as the latent heat of water, as is further described here in Section 3.1.3.

The specifications of the reaction chamber itself are driven by the reaction products and reaction conditions. First, because of the nature of this activated aluminum-water reaction, the chamber material must be resistant to embrittlement by both hydrogen and gallium. Second, it was empirically determined that the batch reactor should be at least three times larger by volume than the initial amount of fuel to ensure that reaction is not stifled prematurely by compaction of the AlOOH byproduct [10]. Finally, because the thermal management system relies on heat transfer via boiling off excess water, the reactor must be able to withstand temperatures up to the saturation temperature of water at a maximum system pressure of 2 bar (up to 120 °C) for extended periods of time. These specifications consequently drove the design of a custom 316 stainless steel reaction chamber with a total internal volume of 5 L, which could accommodate roughly 6 kg of aluminum fuel. The chamber was constructed by welding flanges onto a 6.25 in OD pipe segment. Two 1/4 in Swagelok tube fittings were welded onto the reactor as inlet and outlet ports.

With this system design, the only controllable input to adjust the hydrogen production rate is water flow into the reaction chamber. This makes controlling the system especially difficult because the reaction dynamics are highly nonlinear as a function of pressure, temperature, geometry, and fuel distribution within the reaction chamber. Our approach for this initial prototype was to apply a simple PID controller to the pressure in the reaction chamber. The goal is to keep the pressure in the system high enough for the fuel cell to produce the necessary power. It is important to note here that this simple approach is only feasible if the reaction chamber is hot enough such to neglect the reaction kinetics as a first order approximation and if the power draw from the fuel cell is known and constant. Fig. 3 shows the hydrogen output as a function of time for a typical batch aluminum-water reaction, and illustrates that for a significant portion of the reaction, the hydrogen production rate is constant. It is hypothesized that this is due to the fact that as the AlOOH byproduct is produced and expands, it distributes unreacted aluminum fragments throughout its low-density foam-like structure. Consequently, the rate limiting time scale in this regime is the diffusion of water throughout the AlOOH, which goes as  $l^2/D$ , where  $l$  is the char-

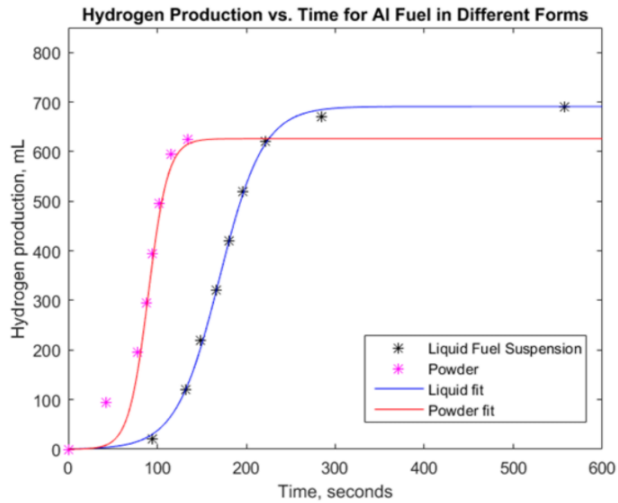

Figure 5-2: Hydrogen Production over Time of Aluminum Powder and an Aluminum Suspension, Fit to Logistic Functions

FIGURE 3. Typical aluminum-water reaction progression.

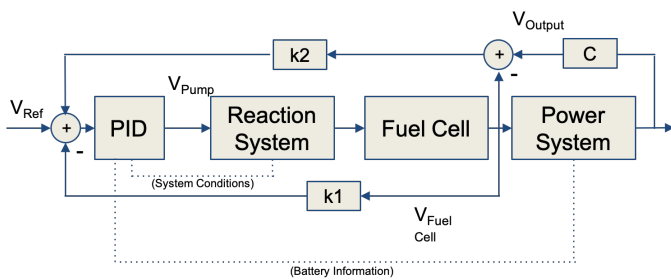

FIGURE 4. Control system diagram for the 3 kW reactor.

acteristic length associated with the  $\text{AlOOH}$  volume and  $D$  is the diffusivity of water in  $\text{AlOOH}$ . Given that  $l$  here is constrained by the dimensions of the reactor and therefore held roughly constant, the reaction dynamics present themselves as roughly linear in the steady state operating regime, and thus the use of a simple PID controller to hold hydrogen pressure constant is reasonable.

Also illustrated in Fig. 3 is the reaction start-up transient that results from the fact that the reactor has yet to warm up. Because the reaction rate follows the typical Arrhenius exponential rate law, at low temperatures, the reaction kinetics become the limiting time-scale. In operation, a start-up routine initially pumps 100 mL of water into the reaction chamber and then waits until the temperature reaches near  $100^\circ\text{C}$ . The built-up hydrogen from this start-up process is purged via a one-way valve in an effort to purge the system of oxygen and other gasses that remained in the system from the refueling process. Once the system is warmed up, the control scheme shown in Fig. 4 is used to stabilize the system pressure during steady state operations. In

this early prototype, feed-forward control was utilized to appropriately bias the controller input based on knowledge about the expected power draw in order to handle transients during simple load following. In the majority of operating conditions, however, most significant load fluctuations are handled by the on-board battery bank, described in further detail in Section 3.1.4. With the batteries handling load spikes, the primary function of the fuel cell is to constantly recharge the batteries. The required power output of the fuel cell can therefore be inferred by the state of charge of the battery bank, informing the controller of an appropriate water flow rate set point around which the system pressure could be stabilized.

In order to inform the control system and ensure that the system operates safely and efficiently, a number of sensors relay information back to the primary CPU controlling the system. The reactor is outfitted with a pressure transducer as the primary feedback for the reaction controller, as well as thermocouples at both the inlet and outlet of the reaction chamber to monitor the reactor temperature (especially during start-up) and the output hydrogen and steam mixture respectively. Additionally, because the system relies on gravity to separate the condensed water from the hydrogen stream (see Section 3.1.3), an accelerometer is used to detect that the reactor module is at a suitable orientation for safe operation. If the orientation of the reactor module goes outside this range, all pumps shut off and the system is purged of hydrogen.

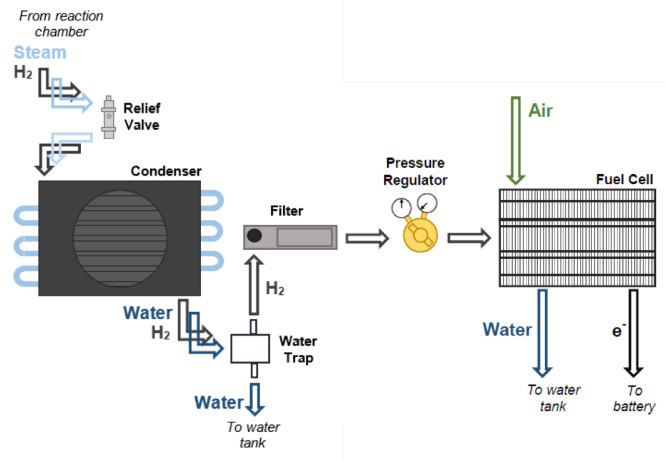

FIGURE 5. System diagram for the 3 kW emergency power supply's hydrogen conditioning subsystem.

**3.1.2 HYDROGEN CONDITIONING** Hydrogen must be supplied to the fuel cell within a relatively narrow range of temperatures and pressures as specified by the fuel cell manufac-

turer. Additionally, this hydrogen must be stripped of oxygen, water, and other gasses that are potentially harmful to the platinum catalyst of the PEM fuel cell used in this power supply. The radiators, described in further detail in the thermal management section, have the dual purpose of cooling the hydrogen and removing excess steam from the product stream coming from the aluminum-water reaction system. After the radiators, gravity is used to separate out the condensed water, and what remains is a mixture of hydrogen and trace amounts of carbon dioxide, nitrogen, and oxygen, all at a relative humidity of 100%. Carbon dioxide, nitrogen, and oxygen are present initially due to the system being open to air during fuel refilling; however, during start up, the first liter of hydrogen is purged to the atmosphere after the aforementioned start-up routine, thereby significantly reducing the remaining concentration of carbon dioxide, oxygen, and nitrogen. In steady state operating conditions, dissolved oxygen in the input water to the reaction system is continually released into the hydrogen stream. To scrub the product stream of oxygen, catalytic converters with a palladium catalyst removes the remaining oxygen promoting its reaction with hydrogen to produce water vapor. This vapor is then removed from the input stream via an in-line desiccant, as indicated in Fig. 2 as “CATALYTIC CONVERTER 2/2” and in Fig. 5 as “Filter”. Once dry and devoid of oxygen, the remaining room-temperature, pure hydrogen gas is passed through a pressure regulator that maintains a constant pressure of 0.5 bar (gauge) at the inlet of the fuel cell.

**3.1.3 THERMAL MANAGEMENT** At steady state operating conditions, this power system dissipates a significant amount of thermal energy generated both at the reaction chamber and the fuel cell. In the reaction chamber, the reaction between aluminum and water is highly exothermic ( $\Delta H_{rxn} = 430$  kJ/mol Al at 100 °C), with roughly half of the initial chemical energy of the activated aluminum fuel being released as heat. The remaining energy is converted to chemical energy stored in the gaseous hydrogen evolved from the aluminum-water reaction (429 kJ/mol Al<sup>1</sup>). Given the required hydrogen flow rate of 40 slpm, the reaction system must react 0.017 mol Al/s, resulting in 7.31 kW of waste heat at the reactor.

To manage this heat release, excess water is pumped into the reactor, where it boils off into steam, carrying with it the excess thermal energy as latent heat. This steam subsequently passes through two car radiators (BAE Systems 70-05428 Humvee Rear A/C Evaporator Coil) in series, each with external forced air convection provided by fans operating at volumetric flow rates of 0.52 m<sup>3</sup>/s. The steam is condensed in these radiators and the latent heat is carried away with the air exhaust. The hydrogen is separated from the liquid water via a simple gravity-operated water trap. An ultrasonic water level sensor is used to detect the

<sup>1</sup>This value is computed using the higher heating value of hydrogen and the stoichiometric ratios given in Eq. 1

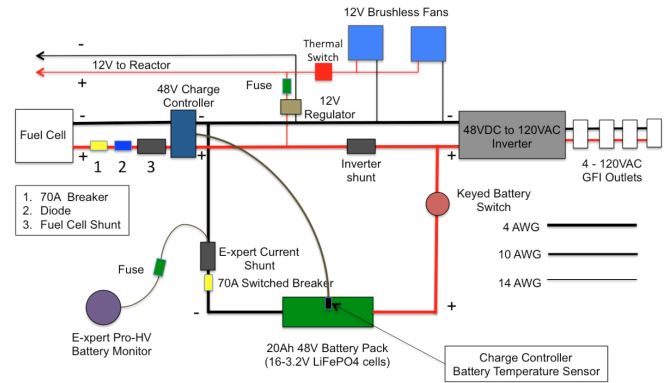

**FIGURE 6.** Electrical subsystem component layout for 3 kW power supply.

build up of water at the bottom of the water trap and accordingly sends a signal to the main controller to activate a separate diaphragm pump that recirculates the water back into the reaction chamber.

Thermal energy must also be dissipated at the hydrogen fuel cell. The fuel cell’s 40% electrical energy conversion efficiency means that another 7.5 kW of heat must be dissipated at the fuel cell stacks during 3 kW steady operating conditions. To this end, we found that the stock fans equipped with the fuel cell were sufficient for maintaining allowable stack temperatures of 65 °C. The fuel cell was carefully mounted on the reactor module structure so as to allow adequate airflow to the fans.

**3.1.4 ELECTRICITY GENERATION** The target steady state electrical power draw for this system was specified at 3 kW at 120 VAC. To meet this demand, a Horizon H-3000 PEM fuel cell was chosen for generating electrical power from the hydrogen product of the aluminum-water reaction. This fuel cell was chosen for its nameplate efficiency of 40%, ability to operate with ambient air at temperatures between 5-30 °C, and relative resilience to humidity. The output of the fuel cell varies between 35-65 VDC by the IV curve shown in Fig. 7. In order to meet the specified power requirements without compromising the system’s ease of deployment and desired ruggedness for emergency applications, a physically separate electronics systems enclosure was designed and fabricated, as shown in Fig. 8. This system is comprised of three primary components: a battery pack, charge controller, and a DC-AC inverted. Combined with various sensing and voltage regulation equipment, this system meets both the 120 VAC load at four GFCI outlets and power requirements for the 12 VDC controllers, auxiliary equipment (pumps, fans, etc.), and fuel cell controller of the main system. Fig. 6 shows the circuit layout of this electrical system.

The battery pack for this system is crucial for handling load

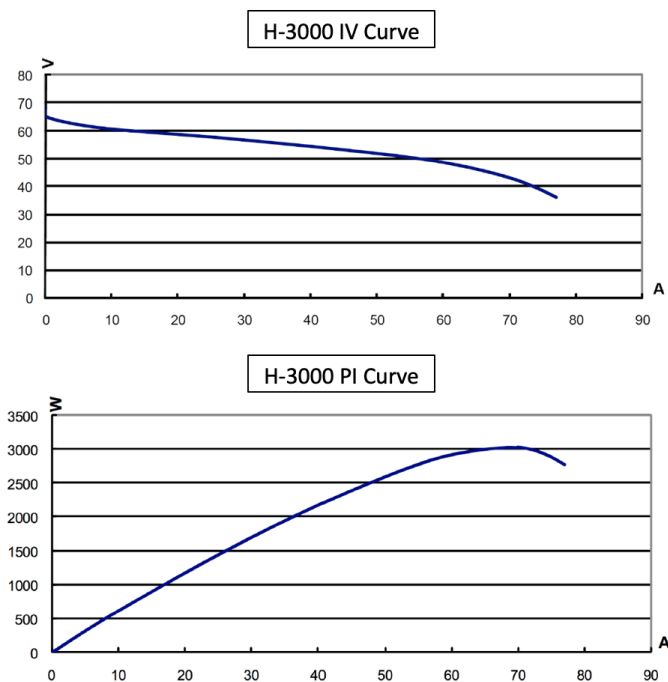

**FIGURE 7.** IV and PI curves for the Horizon H-3000 PEM fuel cell used for the 3 kW power system.

peaks without having to directly ramp up the reaction rate in the reaction subsystem. The pack chosen for this prototype system is comprised of 16 lithium ion batteries, each with 20 Ah capacity and cell voltage of 3.2 VDC, wired in series, which result in a total pack voltage of 51.2 VDC. At full charge, this pack can supply 3 kW for roughly 20 minutes. Though this pack is rated for continuous discharge at 100 A, the current was intentionally capped at 70 A with a breaker in series of the negative line to increase the safety factor given the 3 kW power specification, and the pack is further protected by a balancing board with an 80 A over-current protection. A charge controller is used to step down the voltage of the fuel cell output to the optimum charging voltage of the battery pack based on the temperature and state of charge of each cell. For this purpose, an Outback Power FLEX-max 80 charge controller was chosen given its high efficiency (97.5%) and programming flexibility. Finally, an inverter is used to convert the varying DC output voltage of the fuel cell to 120 VAC 60 Hz to be compatible with most standard appliances and electronic devices in the US. Here a Voltech HT-S-3000 inverter was chosen for this application.

**3.1.5 SYSTEM INTEGRATION** The reactor module is built on a 1.2x0.6x1 meter frame comprised of 80/20 T-slotted aluminum extrusions, chosen for ease of construction and strength/weight requirements. In the final prototype assembly,

the 80/20 extruded bars were fastened together using three standard 80/20 parts: braces, tee plates, and right-angle brackets. Four 20 cm air-ride casters enable safe transport of this module. Key components like the fuel cell and reactor are additionally shock mounted using soft rubber spacers to minimize vibration during operation and transport.

Where possible, the tubing used to connect various components in the reactor module is 316 stainless steel connected via Swagelok tube fittings, which create a gas-tight metal-metal seal. The primary exception to this is the radiator used in the thermal management subsystem. For this prototype, pre-fabricated car radiators made from copper tubing were used as a proof-of-concept. It is noted here that copper is susceptible to hydrogen embrittlement and these components will therefore would need to be replaced in future iterations.



**FIGURE 8.** Power conditioning components, as well as the batteries and battery management subsystem are housed in separate rugged container for the 3 kW power supply.

The power electronic components are enclosed in a Pelican iM3075 transport case as depicted by Fig. 8. The mounting structure was fabricated to the case's dimensions using 20 mm square 80/20 extrusions, which were then assembled using the appropriate brackets. The structure is comprised of two nested inner and outer sub-structures. The former is attached directly to the case and is used to mount the panel onto the top of the power electronics module. The latter is shock mounted to the external structure using four rubber vibration/damping mounts each rated for 59 kg. Each component was individually mounted to the internal 80/20 structure, considering the operating requirements, such as ventilation and electrical insulation requirements. These include but are not limited to, a 2 cm clearance on the fan end of the inverter and proper air circulation across the battery pack and charge controller. There are three connections between the reac-

tor module and the power electronics module. The connection points are found in the power electronics module on the top left corner of the panel shown in Fig. 8 and below the fuel cell on the reactor module. The first connection is the 48 VDC line from the fuel cell to the power electronics box. The second connection is the 12 VDC line from the power electronics module to the reactor module. This line provides power to all the auxiliary equipment (controls, water pump from water tank to reactor, sensing equipment, fuel cell controller, fuel cell fans and condenser fans) via a 48 VDC to 12 VDC converter. Current is sensed on the hot line of both the fuel cell and the inverter input using sense current shunt resistors and an optically isolated sensing circuit.

**3.1.6 PERFORMANCE** The 3 kW power system was able to stably produce power over the target operating period of one hour. Given the slow aluminum-water reaction rate at start-up, it often required several minutes for the system to come up to a suitable temperature for steady operations. Starting the controller with a cold system results in a significant pressure spike due to the considerable time lag between the water input and associated hydrogen generation. In operation, the start-up routine does not affect basic functionality of the system, as the batteries have adequate capacity to supply the full power during this initial idle period.

The final weight and size of this unoptimized 3 kW aluminum fueled generator is on par with the equivalent diesel-powered system; however, the system-wide efficiency of the prototype shown here is only 20% given that half of the energy in the aluminum is being dumped as waste heat and the fact that the fuel cell is 40% efficient. The system-wide energy density is further decreased when taking into consideration the amount of water required to run this reaction, but this can be neglected if water is available on site. It has been found that this reaction can proceed with brackish or gray water, so the availability of water is a reasonable assumption in many applications. Compared with modern diesel generators that can achieve efficiencies of 40-50% [5], the efficiency of this system is does not compare well; however, the fuel itself is two times more energy dense than diesel, and therefore the volume of fuel required is comparable in both systems. Additionally, the aluminum-powered system offers the additional benefits of being able to be run inside, quietly, and as a safe heat source for cooking, sterilization, or desalination/ water purification, further increasing the total system efficiency where these applications are necessary.

### 3.2 BMW i3

After proving the capabilities of aluminum fuel in a 3 kW generator, an even higher power output system was attempted. A 10 kW aluminum fueled electric generator was designed and built to demonstrate the ability of aluminum to act as a viable fuel source for higher powered systems such as vehicles. This

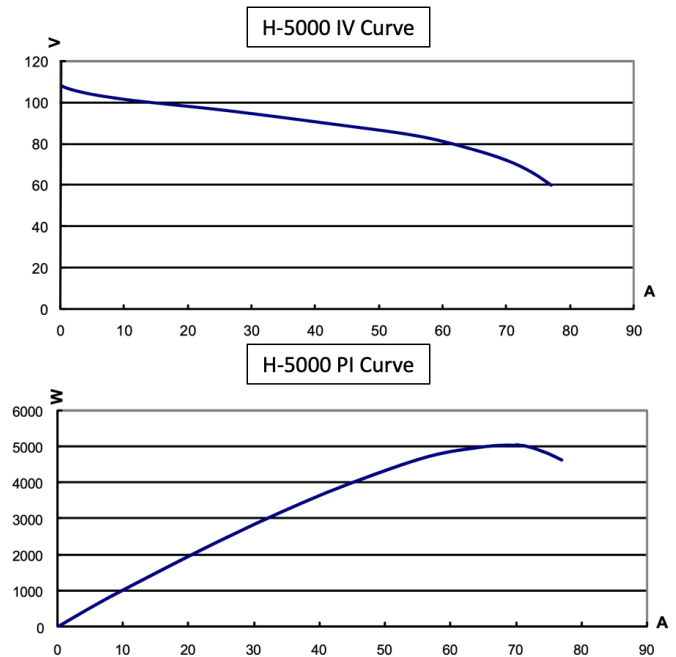
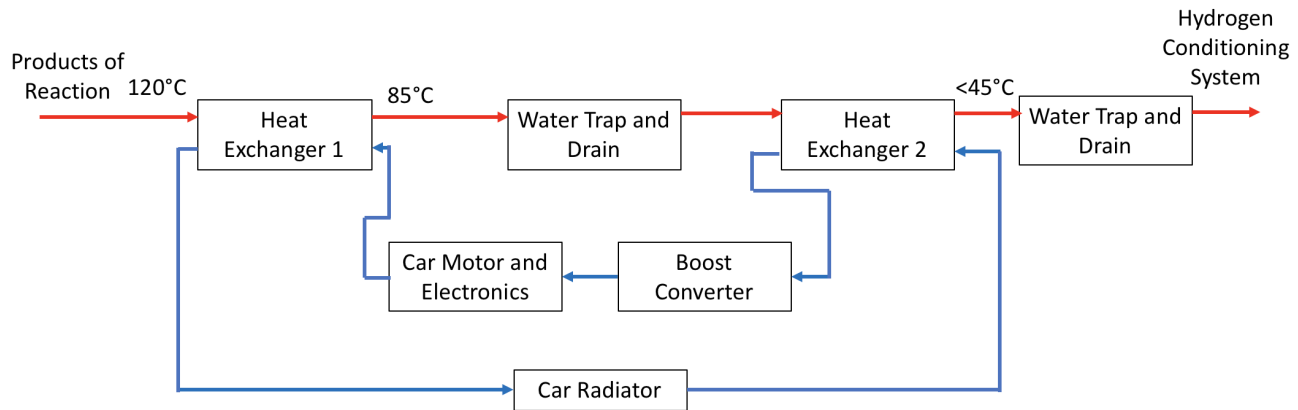

**FIGURE 9.** IV and PI curves for the Horizon H-5000 PEM fuel cell used for the BMW i3 power system.

system was installed in the rear cabin of a BMW i3 and generated 10 kW of electrical power to charge the vehicle’s battery. The primary challenges of this system were those of scaling up the reaction chamber and heat dissipation while maintaining a controlled system and small footprint, as well as challenges of integration into the BMW i3.

**3.2.1 INCREASED POWER** This system was powered by two Horizon H-5000 5 kW PEM hydrogen fuel cells that each operated at a maximum efficiency of 40%. Fig. 9 shows the IV and PI curves for this particular model. In order to operate these fuel cells at full capacity, a steady hydrogen flow rate of 120 slpm was required. Rather than store large amounts of hydrogen within the system to operate the fuel cells, this hydrogen was produced on demand through the continuous reaction of 1.7 grams of aluminum each second. By producing the hydrogen on demand and immediately consuming it in the fuel cells, this system circumvented the numerous safety and logistical challenges associated with pressurized hydrogen storage. Achieving a steady aluminum-water reaction at such a high rate required the implementation of a new PID controller to regulate the water input to the reaction chamber. Additionally, a mixer was added to minimize the effects of oxyhydroxide buildup within the reaction chamber and to ensure that new water can easily reach unreacted fuel within the chamber. In future work, the development of a plug flow reaction chamber would greatly simplify this system as





**FIGURE 10.** Thermal management subsystem design for 10 kW BMW generator.

it would allow for the continuous elimination of reaction waste.

While producing 120 slpm of hydrogen this aluminum water reaction also released 28 kW of thermal energy. It was imperative that the system be capable of effectively dissipating this heat to ensure the safety of the system and passengers. Additionally, the PEM fuel cells used required that their hydrogen input be no hotter than 40 C. The heat dissipation within this system was done using a two-stage cooling design that takes advantage of the car’s internal radiator as outlined in Fig. 10. In this system, a mix of pressurized hydrogen and steam leaves the reaction chamber at 120 C. The gas is then passed through an initial high temperature heat exchanger that cools the gas to approximately 85 C, condensing most of the water vapor. With the majority of the water removed from the gas, the gas is now primarily hydrogen and of significantly lower thermal mass allowing it to be easily cooled to 40 C in the second heat exchanger. The water condensed through both of these cooling stages is then recycled back into the systems water tank. Using this two-stage cooling system ensures that the hydrogen was cooled to the requisite 40 C and allows the majority of the heat transfer to occur in the first heat exchanger where the large temperature difference between the gas and coolant fluid ensures higher thermodynamic efficiencies.

**3.2.2 INTEGRATION** Integrating a 10 kW system into a BMW i3 demonstrated that not only is this technology fundamentally feasible, but that it can be practically implemented in everyday systems. This generator was integrated into the BMW structurally, thermally, and electrically, allowing the power system to operate without impeding the safety or performance of the vehicle in any way.

The final prototype 10 kW generator system weighed approximately 230 kg when fully fueled. While this was within the cargo capacity of the vehicle, for a mass this large BMW

engineers recommended mounting all major components to designated structural hard points within the car. This ensured that the system was secured in place even while driving at highway speeds, and that the installation and mounting of the system would not compromise the structural integrity of the vehicle in any way.

As mentioned previously, the thermal management subsystem took advantage of the car’s internal radiator. The radiative capacity of the car’s standard radiator was sufficient to handle the added thermal load of the reactor system, however temperature sensors in the coolant line were also used to ensure that the coolant fluid was not being heated to dangerous levels during system operation. To install the thermal management subsystem, we cut and diverted the coolant loop of the car into two additional heat exchangers as outlined in Fig. 10. These heat exchangers were placed at high points within the car as they were used to condense water that was then drained downwards via gravity. While effective, these additions caused the coolant loop to have increased fluidic resistance, and the car’s internal coolant pump was unable to pump the coolant at a sufficient rate to cool the system. To combat this, a supplemental pump was added to the loop as well as a pressure gauge to accurately control the flow rate and pressure within the coolant loop. With these additions the coolant successfully flowed through the car’s standard coolant loop as well as the additional heat exchangers at a consistent flow rate and effectively cooled the hydrogen stream.

Electrical integration into the BMW was comprised of both high voltage and low voltage power lines. The high voltage line connected the 10 kW power system output to the BMW battery charging system at approximately 350 V. This was done using a boost converter to increase the voltage from approximately 90 V coming out of the Horizon fuel cells to the voltage of the BMW’s battery which varied from 260 to 400 V depending on its state of charge. This power was delivered directly into the high voltage bus located in the BMW’s Electrical Machine Electronics mod-

ule (EME). The low voltage line was used to power auxiliary equipment within the generator system such as pumps, fans, and relays which operated primarily at 12 V. This low voltage power was taken directly from the BMW 12 V line already integrated and made available for passengers to charge electronics. Due to the high load of the auxiliary equipment within this system which amounted to approximately 1 kW, the standard vehicle charging ports could not be used without blowing internal fuses. Therefore, a line was connected directly from the source of this 12 V power, a DC-DC buck converter located in the EME. This buck converter draws power from the BMW's main battery to charge and power its 12 V battery and has a similar role to that of an alternator in a gas-powered vehicle. Our system installed an additional line coming off of the buck converter and ran it directly into the generator system to power all auxiliary equipment. By integrating both the low voltage and high voltage lines from our system into the BMW, we were able to operate the system completely on the BMW's power without need for any external connections.

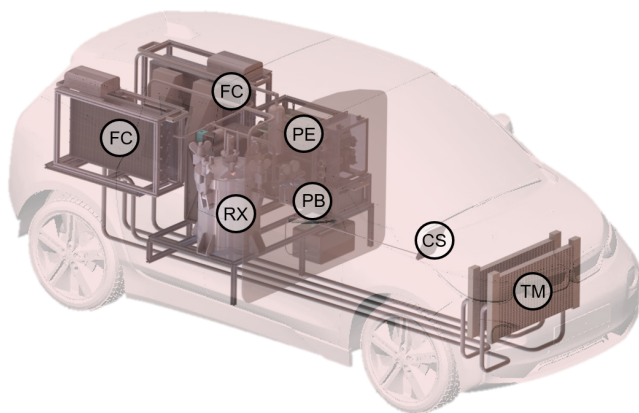

**FIGURE 11.** CAD rendering of the entire 10 kW system integrated into the BMW i3. The components are labeled, where FC, RX, PE, PB, CS, and TM represent fuel cells, reaction chamber, power electronic, polycarbonate barrier, control system, and thermal management, respectively.

**3.2.3 PERFORMANCE** After subsystem testing, the final 10 kW system was assembled and integrated into the BMW i3 with initial tests producing as high as 7.5 kW of electrical power from the aluminum-fueled reactor. Due to the nature of the fuel cells they required a slow ramp up which can take several hours of operation before they reach full power. Limitations in fuel quantity for this testing only allowed us to run the system partially through this ramp up phase, leaving a final maximum

power output of 7.5 kW. In future tests with a larger fuel supply, we are confident that the full 10 kW of power can be achieved.

The system operated safely at steady state while maintaining steady reaction chamber pressures, and without overheating the BMW or its coolant line. Additionally, the vehicle remained fully drivable even with the system structurally integrated, and during operation all electrical components were run completely off of the vehicle's power. Unfortunately, a boost converter failure meant that the high levels of power generated by the aluminum-water reaction inside of the vehicle was unable to charge the vehicle's battery directly and was instead dissipated across large power resistors. The long lead time and high cost of high-power boost converters has kept this from being replaced, however future work need only replace this component to charge the car directly.

This system has successfully shown that not only are high power aluminum-water reactions are possible, but that they can be used to safely generate electrical power at a 10 kW scale. Additionally, this system demonstrated the ability of such designs to easily integrate into current electric vehicles without compromising the safety of the vehicle or passengers. This system utilized aluminum as a highly energy dense fuel to generate electrical power cleanly and quietly at 20% system efficiency. This already matches the efficiency of most gasoline engines, while being fueled by aluminum with double the energy density. In future systems we believe that this efficiency can be pushed even higher by utilizing the heat of the reaction and incorporating higher efficiency fuel cells. This initial prototype system utilized substantial auxiliary equipment such as gas purifiers and boost converters that lowered the overall system energy density to below the levels currently targeted by the DOE for hydrogen fueled vehicles [2]; however, as a proof of concept prototype, future work leaves room for significant miniaturization of the system and greatly improved system energy density.

## 4 FUTURE WORK

After validating these projects at large scale and developing these proof of concept systems, it is clear that there is still significant room for advancements in future work. The first of these advancement comes from the development of a liquid aluminum fuel. This fuel is made by suspending large mass fractions of aluminum particles in a shear thinning oil. The resulting suspension is pumpable and water reactive with the same levels of reaction completion as observed for solid fuel pellets [3]. The use of a liquid fuel for future power systems would allow for the the fuel to be easily metered across the system eliminating the need for batch reactors. In place of the large batch reaction chambers used for both the 3 kW and 10 kW systems, small plug flow reactors can be incorporated. Utilizing a plug flow reactor would not only reduce the size of the reactor system but would also greatly simplify reaction rate control.

Both systems described here operated at approximately 20% system efficiencies by utilizing PEM fuel cells to generate electricity from hydrogen. In their current states, neither system uses the heat produced by the reaction to generate electrical power, however future efforts towards utilization of this energy could lead to significant increases in system efficiencies. One potential concept for such a system would be the use of an internal combustion engine fed off of the steam and hydrogen fuel mix. This engine could take advantage of the thermal energy from the steam as well as the chemical energy of the hydrogen produced in the reaction leading higher overall system efficiencies [3]. Additionally, the ability to use combustion engines in generators such as these is highly desirable as they are incredibly cheap, power-dense, and robust as compared to hydrogen fuel cells.

## 5 CONCLUSION

Presented here are the first large scale power systems (greater than 1 kW) using a novel aluminum based fuel, which on its own has twice the energy density of diesel. The two system designs and prototypes described here both utilize the reaction between this aluminum fuel and water to produce hydrogen, which in turn supplies a PEM fuel cell for electricity generation. Each power system uses a simple PID controller to throttle the flow rate of water into a batch reaction chamber, which contains the fuel required for a typical operating period. The reaction is limited by presence of water and thus does not pose a risk of a runaway scenario. Despite this, however, there are significant start-up and shut-down time scales as the reactor warms up and cools down in between operating periods. In both systems, the batteries supply energy during the start-up period. After this initial phase, a steady flow rate of hydrogen gas is produced and subsequently stripped of water vapor and any oxygen that may be present in the stream. Because the reactor is water cooled by pumping excess water into the reaction chamber that is vaporized by the heat of reaction, the amount of water in this hydrogen stream is significant. The stream is cooled via fan-cooled radiators, and the condensed water is separated by a gravity-driven water trap. The final pure hydrogen is sent through a pressure regulator to maintain a safe operating pressure for the fuel cell, through which the hydrogen finally passes to produce electricity.

These prototype systems show that stable power can be generated using this approach at the kilowatt scale. Compared to other fuels, the energy density of aluminum is twice that of diesel, but by dumping the thermal energy released in the aluminum-water reaction, the system-wide efficiency drops to put the system-wide energy density on par with equivalent diesel systems when only factoring in the electrical power produced. For many applications, however, thermal energy is needed for space heating, cooking, and water purification. In these applications, the system-wide energy density is much greater than that of the equivalent diesel system. Future work must be done to estab-

lish methods for utilizing the thermal output of the aluminum-water reaction to produce additional electricity for applications in which the thermal energy is not otherwise utilized.

## ACKNOWLEDGMENT

The authors would like to thank Mike Wardlaw, the Office of Naval Research, and Lincoln Laboratory for funding this work (Grant No. N0001417MP00504). The work presented here would also not have been possible without the hard work of the students in MIT's 2.013 and 2.014 capstone classes. Finally, the authors would like to thank BWM for their donation of a new i3 for this work.

## References

- [1] Babak Alinejad and Korosh Mahmoodi. "A novel method for generating hydrogen by hydrolysis of highly activated aluminum nanoparticles in pure water". In: *International Journal of Hydrogen Energy* 34.19 (Oct. 2009), pp. 7934–7938. ISSN: 0360-3199. DOI: 10.1016/J.IJHYDENE.2009.07.028.
- [2] *DOE Technical Targets for Onboard Hydrogen Storage for Light-Duty Vehicles*. Tech. rep. US Department of Energy, 2017.
- [3] Jason Fischman. "The Development and Characterization of Aluminum Fueled Power Systems and a Liquid Aluminum Fuel". MSc Thesis, MIT, 2019.
- [4] Peter Godart et al. "Hydrogen production from aluminum-water reactions subject to varied pressures and temperatures". In: *International Journal of Hydrogen Energy* (Apr. 2019). ISSN: 0360-3199. DOI: 10.1016/J.IJHYDENE.2019.03.140.
- [5] Tomoyuki Kogo et al. "High Efficiency Diesel Engine with Low Heat Loss Combustion Concept - Toyota's In-line 4-Cylinder 2.8-Liter ESTEC 1GD-FTV Engine". In: Apr. 2016. DOI: 10.4271/2016-01-0658.
- [6] Jorge Macanás et al. "Hydrogen generation by aluminum corrosion in aqueous alkaline solutions of inorganic promoters: The AlHidrox process". In: *Energy* 36.5 (May 2011), pp. 2493–2501. ISSN: 0360-5442. DOI: 10.1016/J.ENERGY.2011.01.041.
- [7] A.A. El-Meligi. "Hydrogen production by aluminum corrosion in hydrochloric acid and using inhibitors to control hydrogen evolution". In: *International Journal of Hydrogen Energy* 36.17 (Aug. 2011), pp. 10600–10607. ISSN: 0360-3199. DOI: 10.1016/J.IJHYDENE.2011.05.111.
- [8] A.V. Parmuzina and O.V. Kravchenko. "Activation of aluminium metal to evolve hydrogen from water". In: *International Journal of Hydrogen Energy* 33.12 (June 2008),

pp. 3073–3076. ISSN: 0360-3199. DOI: 10 . 1016 / J . IJHYDENE . 2008 . 02 . 025.

- [9] Jonathan Slocum. *Activated aluminum fuel*. June 2016.
- [10] Jonathan Thurston Slocum. “Characterization and science of an aluminum fuel treatment process”. PhD thesis. Massachusetts Institute of Technology, 2017.
- [11] Jeffrey T. Ziebarth et al. “Liquid phase-enabled reaction of Al–Ga and Al–Ga–In–Sn alloys with water”. In: *International Journal of Hydrogen Energy* 36.9 (May 2011), pp. 5271–5279. ISSN: 0360-3199. DOI: 10 . 1016 / J . IJHYDENE . 2011 . 01 . 127.