

NIGHTRISE

Through the Valley of Jabal ‘Amil’s Shadow

by

Mohamad Nahleh

Bachelor of Architecture
American University of Beirut, 2018

Submitted to the
Department of Architecture
in Partial Fulfillment of the Requirements for the Degree of

Master of Science in Architecture Studies

at the
Massachusetts Institute of Technology
June 2021

© 2021 Mohamad Nahleh. All rights reserved

The author hereby grants to MIT permission to reproduce and to distribute publicly paper and electronic copies of this thesis document in whole or in part in any medium now known or hereafter created.

Signature of Author:

Department of Architecture
May 19, 2021

Certified by:

Sheila Kennedy
Professor of Architecture
Thesis Supervisor

Accepted by:

Leslie K. Norford
Professor of Building Technology
Chair, Department Committee on Graduate Students

Thesis Supervisor

Sheila Kennedy, MArch
Professor of Architecture

Thesis Readers

Mark Jarzombek, PhD
Professor of the History and Theory of Architecture

Nasser Rabbat, MArch, PhD
Aga Khan Professor
Professor of the History of Architecture

NIGHTRISE

Through the Valley of Jabal ‘Amil’s Shadow

by

Mohamad Nahleh

Submitted to the Department of Architecture on

May 19, 2021

in Partial Fulfillment of the Requirements for the Degree of
Master of Science in Architecture Studies

ABSTRACT

This thesis is about the night, and particularly about nightrise, which I propose here as the social and cultural construction of the nocturnal landscape. It sites itself along a twenty-six-night walk across the Lebanese hinterland that I made in August 2020, where moving shadows begin to awaken amorphous subcultures capable of weaponizing their formlessness in the name of self-preservation. Because the night resists the reign of any solitary subculture, these nocturnal cohabitations often rely on unspoken rules of civility all but invisible to strangers. And it was on the sixth night of this walk into the heart of Jabal ‘Amil – what is today known as South Lebanon – that my transgression of these rules was matched with an act of hostility that, strangely, culminated in the opportunity to imagine and implement an architecture of nightrise: a path on the southern border of Lebanon between a mountain and a river. If a path for the day seeks to impose the lone perspective of a single direction, then this path for nightrise revels in the unseen, in the ability to interrupt, and perhaps invert, the ubiquitous association between eyesight and insight. The erasure of the unidirectional line comes to propose a series of scattered stations that whisper, hint, and conjure countless variations of the same path in the minds of its visitors. These stations draw out the nocturnal qualities inspiring some of Jabal ‘Amil’s oral myths and legends, and the politics that are deeply rooted within them: from distressing celestial appearances to the imaginal world of the Jinn, and from tales that follow the spread of Shi’ism to the darkness surrounding the famous proverb, “Look under any stone in Jabal ‘Amil and you will find a poet.” Unfolding across the pages of this thesis is thus a peripatetic journey of two nocturnal voyages, one that begins in the past with the stories of my walk across Lebanon, and another in the future, on the Path of Nightrise, which will be implemented in the months following the submission of this work.

Thesis Supervisor: Sheila Kennedy

Title: Professor of Architecture

ACKNOWLEDGEMENTS

Light, it is said, is rewarded to those who manage to make it to the end of the tunnel. And yet it is the journey through darkness that has perhaps been most fulfilling throughout this thesis. Thanks goes first to my advisor, Sheila Kennedy, who took those first steps into the night with me, and who has offered me the most thought-provoking series of weekly discussions since. Mark Jarzombek did not hesitate to join me in embracing the nature of this walk, and it is thanks to him that I am able to recognize myself in this work. I am indebted to Nasser Rabbat for encouraging me to close my eyes on this journey and embrace the world of the Aleph and the unseen. Thank you also to Cynthia Stewart for her kindness and support throughout my time at MIT. It is with profound gratitude that I must also thank my family— my parents, my aunts, my brother Nader and his wife Faten. Their love, care, and support allowed me to find the tunnel in the first place. Thank you to friends who joined me along the way and made sure to keep me grounded and sane. Our conversations have become invaluable to this thesis. Thank you to Meriam Soltan who, much like Umm Kamil, was there to listen to every word, thought, and idea, and who made the journey from Jabal ‘Amil to MIT worthwhile. Thanks also to Batoul Faour and Taha Barazy for helping me visualize and share what would have otherwise lingered in the darkness of my imagination.

1. INITIAL THOUGHTS.....	6
2. PART ONE: NIGHTS ONE TO SIX.....	10
3. PART TWO: NIGHT SIX ONWARDS.....	63
a. THE PATH.....	64
b. UMM KAMIL.....	93
c. A LESSON IN ASTRONOMY.....	109
d. TARIK AL-NAHR.....	131
e. THE CAVE.....	156
4. SELECTED BIBLIOGRAPHY.....	181
5. APPENDIX.....	187

1. INITIAL THOUGHTS

Five o'clock on the second of August 2020 found me leaving Beirut to embark on a month-long journey across the Lebanese countryside. Only forty-nine hours later, at 6:07 P.M, would my voluntary departure from the capital be echoed by the exodus of countless families fleeing the pestilential vapors that erupted from the port that night. Thickened by the noxious fumes that enveloped the city, the nocturnal air acquired a toxic materiality; an ominous black cloud that swallowed the evening and resurrected the same fear of darkness that compelled our preindustrial ancestors to avoid inhaling the nighttime atmosphere¹. The explosion in Beirut, through its discharged chemicals, not only eradicated neighborhoods, but dismantled for a few hours the ubiquitous construction of the night as an absence, as a barren wasteland that demands immediate illumination. In the worst way possible, the night on the fourth of August rebelled against its blazing colonization, and through its malignant fog, quickly transformed from prey to predator.

At the heart of this thesis exists an awareness, not only of our light-centric design disciplines, but also of their compulsive perpetuation of attitudes that rely on the relocation, domestication, and criminalization of darkness. Concealed behind these seemingly natural attitudes are old realities narrated through the lens of the settler(s); tales of public safety, order, and duty, all warranting the inevitability of an eternal day. Dignified by religious calls to glorify light and conquer the shadows, these tales soon emerged as metaphors, as internalized rules of civility that proclaimed the nineteenth century construct, not as a temporary reinvention of the night, but as a universal and timeless reality that thrives on its repression. Weaponized by states and their allies, lighting worked to prolong and perpetuate the lavish lifestyles of those who could afford the luxury of delayed slumber, while prolonging the hours of toil for those who could not. A new illuminated consumer culture emerged, basking in the same pools of light that burned clear boundaries within the city, and between the city and the countryside. And thus, the metaphor of the night, born out of violence and eviction, fulfilled its ultimate purpose: death, with virtually no trace that it ever existed, and only after its criminalization of darkness (and of those who choose to, or are forced to, dwell in the shadows).

¹ A. Roger Ekirch, *At Day's Close: Night in Times Past* (London: Weidenfeld & Nicolson, 2006). Ekirch writes, "The moon also impregnated the night air with pestilential damps, widely deemed an even greater menace to human health. Darkness signified more than the temporary absence of light. According to popular cosmology, night actually fell each evening with the descent of noxious vapors from the sky. [...] Fevers and colds were only a few of the contagious maladies ascribed to the raw fumes of night. By entering the skin's pores, dank evening air was believed to imperil healthy organs. [...] Tragically, many persons might have been saved had their chambers been better ventilated at night, especially when occupied by multiple members of a family." 12-14

From the vantage of architectural and urban design, the night is a flawed version of the day; a calamity only alleviated by the countless devices, of different shapes and intensities, that work to emulate the lost character of the sun. Apart from commodifying ‘night design’, our obsessive ocularcentrism, coupled with these capitalistic narratives of security, has reduced us into scripted machines foredoomed to replicate and aestheticize the consumable forms of the day. Excluded from these illuminated ‘polite’ zones are all individuals deemed to jeopardize the established order, whether by subverting the apparent rationality of sight or proposing new modes of nocturnal cohabitation. So ingrained are these discriminative tendencies in the planning and design disciplines, drilled deeply into our theories and praxis, that even the loudest calls for equity fail to recognize the inherent bias of this eternal day. So entrenched are they in all design pedagogies, that recognizing the potential of nightfall, beyond the play of atmospheres and ambiances, proves perplexing. Our dark lines impetuously scorch bright spaces in the night, and so on, ad infinitum. These are the confines of a discourse that equates eyesight with insight.

Although schematic, the current relationship between design and the night is not surprising. As an object of study, it is subdued by a written discourse that is perhaps as binary as the products it yields. Extensively light-centric, its contributions alternate between scientific rationalism and architectural aestheticism, between the quantities of light required to illuminate a space, and the design of artifacts, materials, and even shadows, that further this illumination. Foregrounding the night’s lost agency are also the countless works that render the distinction between sunlight and artificial illumination merely directional. Here, design becomes the formal process through which daylight is captured during the day and electric light is discharged at night. Furthermore, there has been extensive research presented around studies of light pollution, and climate change in general. Design, then, transforms into a set of guidelines that seek to alleviate the environmental impacts of outdoor lighting. Arguably, though, this battle between light and its absence further undermines the potential of design at night. After all, the night, as evidenced through its material, social, and symbolic constructions, is far more complicated than a mere absence. And every definition that frames it through the language of light foreshadows its collapse under the weight of the biased metaphors that have persecuted it for centuries. It is by giving weight to a more nuanced reading of darkness that my journey across Lebanon, a walk of twenty-six nights from the southern to the northern border, sought a new agency for the night; a materiality that isn't stained by corruption and noxious fumes, but by the camaraderies, irrationalities, powers, terrors, spectacles, and encounters that only darkness might uncover.

The walk, as a peripatetic project, and through its engagement with the nocturnal landscape, carries a critique of the discipline that leverages the daily lives of those whose impressions of the night seldom exist in writing. Strangely blended with unknown traditions, these unrecorded beliefs and practices, mostly extinct in urban areas, survive in the landscapes that were harder to police, in the rural areas that managed to protect their nights against colonization. They are the stories of the shepherds, the migrant workers, farmers, refugees, children, and others, whose various constructions of the night join the quotidian to the symbolic and embrace the social and material expansions of the nocturnal territory. Notable here are the gatherings of workers avoiding surveillance, the vegetables ingested to heighten eyesight, the readings of time from the dilating eye to the cosmos, and the divinely blessed waters repelling evil spirits. So, too, are the curfews blighted with sexism, racism and xenophobia, the dubious contracts signed after dark, the evasions of quarantine by undocumented bodies, and the transformations of darkness into sites for the uprising. And yet, even at a time of ravaging political, economic, and epidemiological instability, the rural night resisted the reign of any solitary subculture. A co-conspirator rather than a symbol of social status, it allowed various crowds to inhabit its depths, simultaneously, irrespective of race and gender, class, and sexual orientation.

In the following pages, this thesis will stitch together a non-binary reading of darkness by structuring the walk as its principal artery. It is a construction that foregrounds, rather than softens, the tensions between the oral culture of the Lebanese countryside, the written explorations of Eastern and Western nights, and the relationships between fear, imagination, alienation, sociability, and the night. It is through this stream of seemingly incompatible thoughts and conversations, of borrowed attitudes and fleeting encounters, that I narrate the walk as an ekphrastic journey, as a story of acclimatization, not only to the night, but to a new design imagination. Far from a retrospective retelling of past events, this reading reinhabits the original journey, and engages me, not as a mere observer, but as an omniscient narrator; one with unhindered access to the history of the walk, and above all, its future. In other words, it is a story that unfolds in the present, yet remembers backward, by recalling the conflicting voices of various other authors, and forward, by injecting the walk with its forthcoming contributions: not only to our design disciplines, but also to the nocturnal souls of the Lebanese countryside.

Note: All drawings and photographs in this thesis are drawn or taken by the author.

2. PART ONE: NIGHTS ONE TO SIX

The late-night winds whistled through the deserted landscape, barreling across the empty wilderness that stretched out towards the horizon in every direction. With everything so eerily quiet, only the incessant buzzing of the wild cicadas hinted at the existence of other life in the southern hinterland. The flashlight, meant to offer some comfort in the night, did little to push away the darkness. In fact, it made it seem all the more vast. Dry grass tore at my hiking attire as I pushed my way through the undergrowth. It grabbed and scratched at any exposed skin until I was forced to stop, suddenly aware of how much noise I was making. Perhaps trekking through the wilderness by night had sounded easier on paper.

Camping gear that had seemed light and manageable in the taxi ride here at sunset now dug viciously into my shoulders. With the car and village now nowhere in sight, the only lingering trace of civilization was embodied by the drone of Israeli surveillance aircraft passing occasionally overhead. This was, after all, the heart of Jabal ‘Amil, and Lebanon’s southern border was but a few kilometers away. Legs now heavy with overexertion, I journeyed towards a clearing in the brush to set up camp for the night. With the tent finally assembled, and a cup of noodles boiling away on the portable burner, I moved to click off the flashlight. If I could see myself, then so too, I realized, could others. A beacon that called forth the creatures of this world— and perhaps the next— the flashlight did not offer the solace it had at first seemed to promise.

It was only until later that light of another kind hinted at the presence of visitors in the nighttime. A sparkle of fireflies drifted lazily overhead, the luminescence of their tails glowing through the nylon of the tent. I was a visitor from the city with no idea how to deal with the darkness, and nature had sent a few hundred of its own to help me make some sense of it, if only for a little while. The primary purpose of their illumination, I later learned, is to communicate the desire to mate. Yet what brings life to their kind, is often a death sentence for others. Too many creatures drawn to their glow end up battling it out in the brush beneath them. Others have learned to simply avoid the light. This echoes current discourse on the night, practice that either favors light for surveillance and security, or advocates for its absence based on aesthetic or environmental reasoning. But this battle for or against the light further dissociates us from an understanding of the night as it has itself existed for time immemorial, independent of the constructs that now define it. It is in [Drawing 1.1] that this relationship is visualized as a spatial allegory with three main characters. The firefly here either attracts or repels surrounding insects in a battle for light or its absence. This confrontation is in turn devoured by the unseen predator that is the frog, by the forgotten meanings of darkness specific to a particular

place or people. And the cultural definitions that are the frog are consumed in turn by the python that is the universal, human understandings of darkness to which countless civilizations have contributed. Such is the metaphor of the double ingestion. This walk cuts through that metaphor as an incision through layers that seeks to contaminate each prey with the flesh of its predator in its search for a different nocturnal imagination.



It was on the second night that the firefly flurry was replaced by three distinct circles of light bouncing steadily in the distance. A trio of sisters each swept an old, industrial flashlight across the wild grass to light a path for their latest customer. Not unlike the linkboys that had once led pedestrians home through the city streets of Europe by torchlight, these sisters made money by ferrying night workers across the fields after sunset. Wolfgang Schivelbusch in *Disenchanted Night* likens the activity orchestrated by the linkboys to a type of mobile public lighting, a system that often doubled as a network of police spies and informants². That night, there hardly seemed to be any customers around, and it was already nearly 2:00 AM. “Do you do this all night?” I called over when I was close enough.

“No, we’re going to the river in a bit,” replied the oldest sister. “Do you want to come? But also, for money.” I nodded and together we waited for more customers. But after nearly an hour, it became clear that no one was going to show. The covid curfew had definitely hurt their business. After talking me into paying an extra fee for what would be an ostensibly private tour, the sisters clicked on their flashlights once more and began to walk north. Before long, the moon above was reflected in the current of a narrow stream. The young girls removed their shoes and stepped carefully into the water where they turned their three flashlights towards the deepest part of the stream. It was there that they together illuminated a circle of water until it was overrun by fish dazzled by the sudden stimuli. Where insects on land hurried towards the light of the firefly, fish in the stream swam towards the ingenuity of a resourceful young trio.

The sisters held the three flashlights steady while the oldest among them cast a hand-knotted net into the water and scooped up at least a dozen of the mesmerized fish. Satisfied, they waded back to the riverbank. The youngest sister set herself down near the catch and began to hand them off, one by one, to the other girls. The next sister gutted them while the last separated what remained into bags. The fish itself, they explained, would go to Abou Karim. He had a restaurant and would pay them in both money and batteries for their nightly catch. A second bag sloshed around with the slime of fish liver. The oils they could reclaim from those organs, they said, would light their lamps at home.

This gutting of fish and the extraction of their natural oils soon came to resonate with the breaking of dawn above us. The bloom of first one shade, then countless others across the horizon was everything but the quick flip of the switch that, today, jolts us out of the dark and into the light. Unlike the double

² Wolfgang Schivelbusch, *Disenchanted Night: The Industrialization of Light in the Nineteenth Century* (Berkeley: University of California Press, 1995).

ingestion of the firefly, it was here that darkness – tucked away in the oil hidden within the liver of a fish swimming through the depths of the stream– would ultimately illuminate the home of these child refugees. Watching the sun rise over the stream, the relationship between light and dark was infinitely more nuanced than the casually ubiquitous opposition we have become accustomed to [Drawings 1.2 and 1.3]. Bryan Palmer in *Cultures of Darkness* reminds us that, “Whatever its contents, the night, narrowly understood as a time or broadly perceived as a space, has rarely been welcomed by the day.”³

³ Bryan D. Palmer, *Cultures of Darkness: Night Travels in the Histories of Transgression* (New York: Monthly Review Press, 2000). 18



But the gradual shift from night to day was not the only subtle partitioning unfamiliar to me. Robert Ekirch in *At Day's Close* explains that “Preindustrial societies divided evenings as well as days into well-defined intervals,” and that “Ancient Romans partitioned their nights into as many as ten different periods, which, unlike modern hours, varied in length.”⁴ It was on the third night of the walk that I came to appreciate this gradation at a much more intimate scale, that of the shared mattress in a family home.

A Sudanese family that had found me assembling my tent in a field just a few meters away from their home had, after hearing about my expedition, invited me over to stay the night. With arms full of my belongings, the father led me towards a pair of small rooms roofed with salvaged corrugated metal. Steel shelves lined with a variety of scavenged objects were pushed against the walls of the first room. The entirety of the second was carpeted in thin mattress. It was here that the family of five both lived and slept.

Once inside, the children moved immediately towards their spots below the window. Their mother laid beside them, and the grandmother, in turn, beside her. But the father lingered by the door, trying to determine how best to alter their sleeping arrangements to accommodate me. I ultimately ended up lying next to him, just inside the doorframe. And as we lingered together at the threshold of sleep, the conversation could not but turn towards the recent explosion in Beirut, the city they had decided to leave in search of better opportunities. “Iranian money,” they mumbled in agreement, referring to the South where they now made their home.

At 4:00 am, the father gently stirred his children awake for school, although it was still completely dark outside. The grandmother, already up and rubbing zaatar paste into flat bread, passed us each a sandwich. Curious as to where exactly the children were headed, I packed my things, thanked the women, and followed the rest of the family to school. It was not until half an hour later that monotonous recitation echoed out to us through the darkness, first, from the graveyard, and then from within an abandoned hangar. Those calling for salvation on behalf of the deceased hurried through funerary rituals before daybreak. It was only at that time of night that they had enough space and privacy to bury the latest victims of the pandemic.

⁴ A. Roger Ekirch, *At Day's Close: Night in Times Past* (London: Weidenfeld & Nicolson, 2006). 137

Across the street, children sitting in a circle at the hangar's center recited their lessons at the teacher's instruction. We hurried inside through a break in the old fence and watched as the group made room for the youngest newcomers. The only source of light for the lesson was the flame of a long white candle. Half of their teacher's face bloomed orange, while the other half was thrown into dark shadow. As a gust of wind blew through the abandoned warehouse, she instructed the group to shift in its direction. Only then could their voices be safely carried on into the wilderness, rather than back towards the village.

These schools are illegal not just because of a racist curfew that forbids migrant workers to be out of the house past 8:00 PM, but also because the children are themselves undocumented. According to the sponsorship system, migrant workers that had escaped the abuse of their employers relinquished both their rights and those of their children to lawfully be in Lebanon. These children were born in darkness by mothers who could not go to the hospital and lived their youth in darkness until they grew old enough to appear as though they themselves had come to find work in this country. Night school is one way these families attempt to make a life within such a system and is the only means through which underprivileged children might access some semblance of the education they are denied during the day [Drawing 1.4]. Simone Brown in *Dark Matters*, argues that within "certain acts of cultural production, we can find performances of freedom and suggestions of alternatives to ways of living under routinized surveillance."⁵

The teacher held up a hand to the children, and then pulled out her copy of the Qur'an. Although she was only a volunteer and held an entirely different job by day, for that night, she read from a book for children struggling themselves to learn how to read. One by one, she asked each student to recite a particular verse and explain it to the class. Although not every student was Muslim, this was the only instruction any of them had access to.

This night school, illegal for those whose existence the country did not recognize, had strayed far from the golden age of education and scholarship that had once characterized the South of Lebanon. It was there, across the village of Jabal 'Amil, that scholars had once established schools in service of students from all over the region. But what used to be a hub of literary and scholarly production was now, both

⁵ Simone Browne, *Dark Matters: On the Surveillance of Blackness* (Durham: Duke University Press, 2015). 8

by day and night, a testament to the intellectual decline of a people that now forced learning into the shadows.



The night school sessions devoted to the teachings of the Qur'an resonated all too well with the drawings of a young boy encountered on the fourth night of this walk. Legendary battle scenes and biblical reckonings were scribbled across the pages of his sketchbook, with wondrous plants, animals, and even a few people crowded into the margins of the lined paper. But while everything was drawn out in dry blue ink, red was slashed across the necks of the humans he'd drawn, as if to decapitate them.

"Grandmother did that," explained the boy after noticing my stares. Marking out the figural representation of key persons from the Qur'an, especially prophets, has been common practice in Islam. The red lines across the necks symbolize the severing of the soul required, it is said, to render the sketches inanimate. Only then might figural representation be deemed inoffensive. In decapitating the image, the boy emphasizes that he was not attempting to rival God, the one true creator.

"Come meet her," urged the young boy. "She'll tell you all about this." It was ironic then, that we found his grandmother, Umm Fadel, in the courtyard of her restaurant, slaughtering the cow, two sheep, and ten chickens she'd be serving to her customers come morning.

The slaughtering of the cattle and poultry was a nightly affair for Umm Fadel and her family, and blood possessed a powerful presence here. It flowed across the tiles and into the yard, reaching as far as the flower beds depending on the size of the animal. Umm Fadel rallied her entire family into the process, while cousins sat in the corner picking lentils and boiling beeswax to make candles. As Robert Ekirch notes, "Above all, nighttime commonly blurred the boundaries between labor and sociability. [...] Many tasks became collective undertakings, marked by a spirit of conviviality and companionship."⁶

If the restaurant was part of the home, so too was the slaughterhouse. And it was just as the boy and I slipped into the courtyard to join the family that his eldest brother whispered a prayer towards the sky and sliced cleanly through the neck of a cow hugged to the ground by his two other siblings. They comforted the animal in its last few moments, intent on ensuring the peaceful passing of the cow and the halal nature of the meat. With a last few short breaths, the cow dropped its head to the soil and

⁶ Ekirch, *At Day's Close*. 177

slowly closed its eyes for good. Its body stopped convulsing until the only thing still on the move was the blood that continued to pour out of its neck and across the crimson-stained tiling.



But with the eternal closing of the cow's eye, it is the opening of another that became the highlight of my fifth night. For hours I gazed into the murky eye of a sheep as a shepherd I had met in the hills taught me how to read time in the animal's dilating pupil. The sheep's eye, as it turned out, was the shepherd's favorite clock. I watched as the pupil grew gradually more circular with the steady rise of night. If the hours of a normal clock rotate clockwise to indicate the passage of time, here it was the steady expansion of the pupil that could, after decades of practice, suggest the passage of every minute [Drawing 1.5]. Time for the shepherd, of course, was very different from time in the city. Murray Melbin explains in *Night as Frontier* that "Activities in time are objects in a fixed container. As we fill it densely, we cannot stretch time. We cannot do with it as we did with space by digging into the ground or building up into the sky. There is no alternative but to have one revision in a schedule jostle another activity, and the latter in turn may do the same where it has been displaced."⁷ But there was no digging of time here in the mountains. The shepherd knew what had to be done, and the awareness of time seldom wandered its way into his consciousness.

Intent on heading further south, the shepherd turned towards the trees for direction in the night. He put a hand to the bark in search of its warmest side, the one that growth was favoring. At one point, he even removed his shoes to better feel the moisture in the soil. Convinced, he hoisted himself back up and rallied the sheep towards the valley. A tiny, folded almanac detailed by his wife with the dates and phases of the moon fluttered quietly with the wind from where it was tied to the top of his stick.

"I did bad things during the war," the shepherd confessed to me. "I've walked these hills ever since." Bab the guard dog trotted along beside him. She was the newest of four he'd had since he'd first started walking in atonement. She nipped at the slowest of the flock with a spiked collar around her neck meant to ward off any stray predators in the night. With a whack of the shepherd's stick against a boulder, Bab barked and rallied the flock towards the cave before them. Into the darkness of the cave they disappeared, the entrance of which was itself cast in shadow. Certain that the sheep were now huddled in safety for the night, Bab walked proudly over to the shepherd and rested her head on his thigh. With a few soft caresses, she too fell asleep alongside her protector.

⁷ Murray Melbin, *Night as Frontier: Colonizing the World after Dark* (New York: London: Free Press; Collier Macmillan, 1987). 8



[Come back you animal]

[You animal]

[Come back here you animal]

But sometimes the relationship between human and animal is far less intimate, at least in relation to the farmer I offended that next night. Heaving loudly, and out of breath, he chased me into the valley with a shotgun. Roots and rocks slashed at my ankles until, with a crash, I fell to the ground before him.

“You’re the one that’s been stealing my cow’s milk and dung!” he roared into my face, shaking me violently by the shoulder. The farmer cocked his gun, but then dropped it when he saw the confusion and fear written so plainly across my face. Running for my life into total darkness, well after 2:00 AM, this was the last question I’d have expected from the farmer. It was only when he took a moment to register the tent, and then my backpack, that he realized I was not who he had been looking for. Wordlessly, he extended out a hand in truce and helped me up. Together, we walked back towards the road in silence, unsure of what to say to each other.

“There’s a thief that’s been passing through my farm every few nights,” he said sheepishly after a moment. “He milks my two cows and steals the cakes of manure I’ve got stacked beside the house.” The cow dung, he explained, was dried out in the sun, then kneaded with straw and patted into cakes. He burned those in a furnace for his family to keep the house warm during the winter months. The uses of cow dung had, until then, been completely lost on me. But like the farmer, Dominique Laporte in *History of Shit* reminds us that “The privatization of waste, a process whose universality is not a historical given, made it possible for the smell of shit to be bearable within the family setting, home to the closest social ties. Just as delousing is no longer a front-stoop activity carried out in the presence of neighbors and the mixed company of all classes, the space of defecation has not always been that of interior monologue.”⁸

⁸ Dominique Laporte, *History of Shit*. Translated by Nadia Benabid and Rodolphe el-Khoury. A Documents Book. Originally published as *Histoire de la merde* in 1978. (Cambridge: The MIT Press, 2002). 29

If the subtle progression of the night was teaching me that light and darkness were far from binary, then the farmer made clear that neither were milk and manure. In the same way that the walk has slowly challenged the image of the night as an inferior version of the day, so too had this man in Jabal ‘Amil denied the existence of good or bad excrement. The scenic vision of the countryside perpetuated throughout the city, the quaintness of nature that existed apart from the violence of agrarian capitalism, was dismantled here. This “aestheticized and unspontaneous relationship to nature,” enforced, according to Mathew Beaumont in *Night Walking*, that “the concept of the landscape, which in the eighteenth century signified not the countryside itself but a painting or portion of rural scenery framed for the purposes of aesthetic consumption.”⁹

It is the bodily nature of the cow, the simple assertion of its biological functions, that here undoes the hypocrisy of the image of nature that so many of us grow up with in the city. And after an evening in the farmer’s company, it became clear that the fertile darkness embodied by the cow, where both milk and dung coexisted much like the oil hidden within the fish’s liver, could not be dissociated from the ongoing collapse of the Lebanese economy. With the Lira having lost nearly 80% of its value in less than a year, the theft of dung and milk, while not unprecedented, have become far more common in the wake of this disaster [Drawing 1.6]. Such turmoil, explain Verzier and Van Westrenen, “Invite[s] discussion on the symbolic currency of darkness within racial, socio-political, and environmental consciousness.”¹⁰

Having confirmed that I was not the thief, the farmer asked why I was wandering across the valley so late at night. I struggled through an explanation of my walk, one that made him furrow his brow in confusion, and prompted, what for many across Lebanon, was the most essential question of all. “What is your name,” he asked me, from across a firepit ablaze with one of the dung cakes. For names across Lebanon were immediately indicative of religious affiliation. And in a country as overrun by sectarianism as this, such information often determined how people interacted with one another. The farmer’s accent and the flags that flapped from the roof of his home told me that, like most of those across Jabal ‘Amil, he was a Shi’i Muslim. But my accent, mixed in with a bit of French from the city, confused him.

⁹ Matthew Beaumont, *Nightwalking: A Nocturnal History of London*, Paperback edition (New York: Verso, 2016). 237

¹⁰ Marina Otero Verzier and Francien van Westrenen, *I See That I See What You Don’t See*, ed. Marina Otero Verzier and Francien van Westrenen (Rotterdam: Het Nieuwe Instituut, 2020). 13

I could not but think of how I had felt only a few days earlier as I watched someone with a flashlight pass me by, completely unawares. My knowing their location, though they had no idea of my own presence, suggested a powerful imbalance of power. This same imbalance of power was clear to me here: I was darkness, and my host was holding the metaphorical flashlight, exposed but also blind. And it is perhaps because of this disparity that I told him my true name.

“You’re from the South!” he declared, excited. I explained to him that my family was indeed from the South but that they had all moved to Beirut by the end of the 1970s when the Israeli defense forces had occupied their village in Jabal ‘Amil and established the South Lebanon Security Belt along the southern border. I was one of the first generations born outside the South, in the city rather than the hinterland; a generation that also never returned even after the withdrawal of the Israeli forces. He paused for a few seconds, almost in disbelief, the happiness on his face was unmissable. For him, a son of the South had finally returned home, not only from the city, but from another continent.

“You know what,” he said, “All the stories about the night are with me. But first, let me make us some coffee.” He disappeared into his house for a few moments only to return with three little cups that he placed carefully on a plastic side table: one for himself, and two for me. The smaller of the two he offered me contained Zamzam, holy water he’d brought back straight from Mecca itself. He asked me to wait while he wrote a few words on a scrap of paper, and then placed it into the glass where the ink dissolved into the rest of the water.

“Drink up,” said the farmer. Having sensed my uncertainty, he explained that he’d added two verses of the Qur’an to my drink, and that dissolving the words in the holy water before drinking would protect me from the bad Jinn, the supernatural creatures that too roamed our world, invisible to us. He even said that he detached the letters of the verses to increase their potency, to allow each letter to manifest its energy. Amira El-Zein explains that for Al-Buni, “Arabic letters have their kingdoms, their traditions, and their secrets.”¹¹ For him, “Each letter has its own servants and its own ruler. He deemed them ‘a nation among nations.’”¹²

¹¹ Amira El-Zein, *Islam, Arabs, and the Intelligent World of the Jinn*, First paperback edition, Contemporary Issues in the Middle East (Syracuse, NY: Syracuse University Press, 2017). 82

¹² Ibid.

And so, of course, I drink. And the conversation unfolds, for hours, first about the Jinn that swallowed a man at night in a nearby village, then about a woman who cursed the moon and died on the same day out of intense dehydration. There was even talk about a carrot that blinded a boy instead of improving his eyesight, and a haunted house nearby where it is said that a giant venomous snake with three heads lives and hunts at night. These tall tales eventually turned into stories about the ghosts of several kids who roam Jabal ‘Amil every night in search of vengeance. The kids were discovered dismembered and cooked by poor families to survive. This cannibalism, my host asserted, changed the nights of Jabal ‘Amil forever. He jumped from one story to another so effortlessly, from the gruesome to the terrifying, from the nostalgic to the vindictive, all while integrating his own story and that of his family, who had recently left for city because his kids had decided to attend university there. So charismatic was his story, so smooth and captivating, so fluid and graceful, that I could not but think about him, six months later, as I was struggling to assemble the pieces of mine [Image 1.1]. And so we talked of spirits and ghosts, tall tales and tensions on the southern border, darkness and architecture, until the morning call to prayer sounded across the mountains.

“Why don’t you do something here in the South?” he asked. And before I could answer, he told me I should consider making a project without electricity. “But not something that reminds you that electricity is absent,” he continued. “What is the opposite of a lighthouse I wonder?”

While this was a question I’d spend the next few months thinking about, it was a journey to the Jabal ‘Amil Union of Municipalities that next day at the farmer’s invitation that the project would officially find its footing in the South. “Nahleh?” the head of the union would ask, “Weren’t your grandparents once residents of Taibeh?” They were indeed, and it is precisely because of my reluctance to grapple with my southern heritage and the history of occupation that had uprooted it that I had promised myself to avoid journeying across that particular village. But the night works in mysterious ways. At least that was clear to me as I was sitting in the backseat of a car making its way to Taibeh.



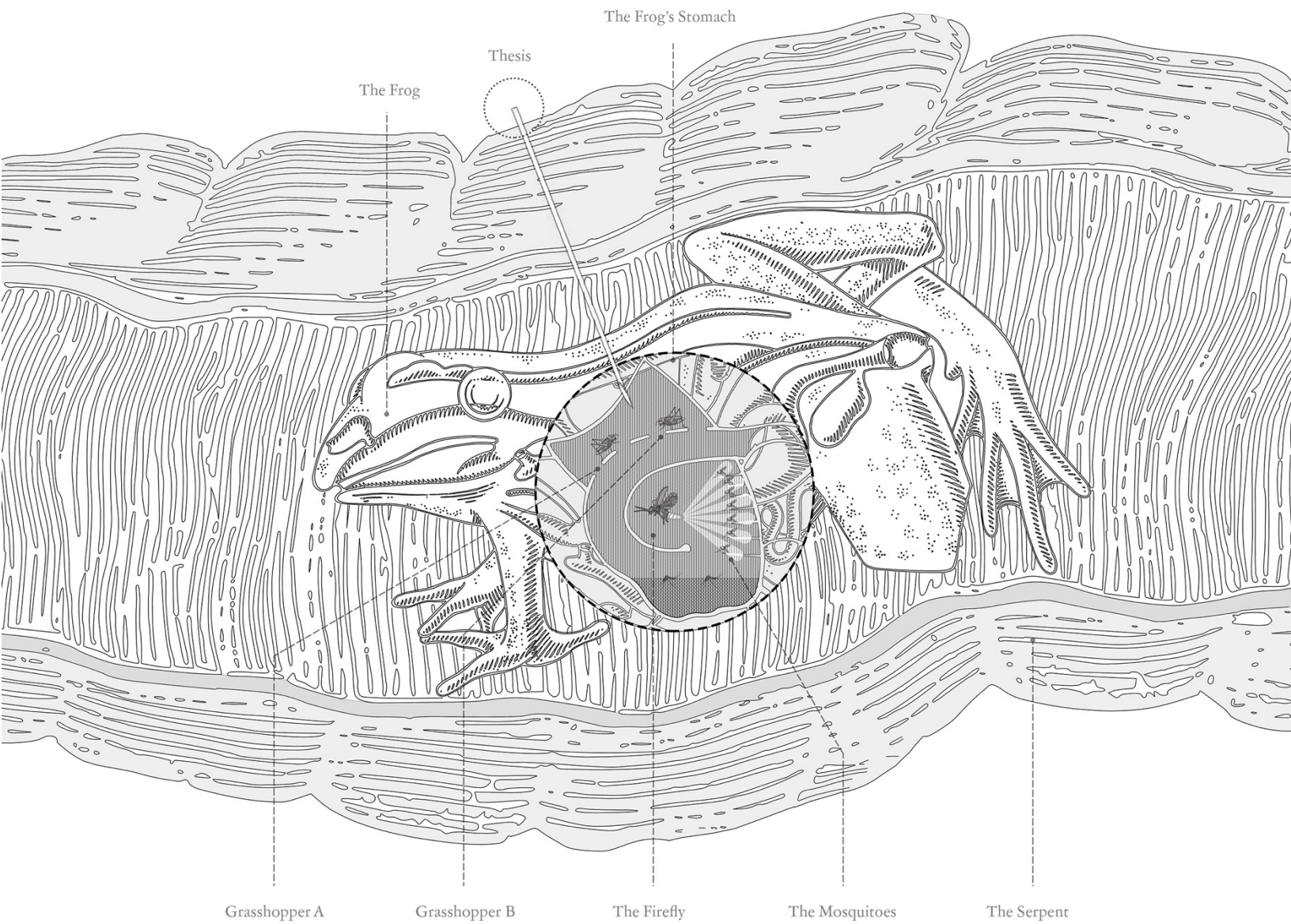

Drawing 1.1 The Firefly and the Double Ingestion.

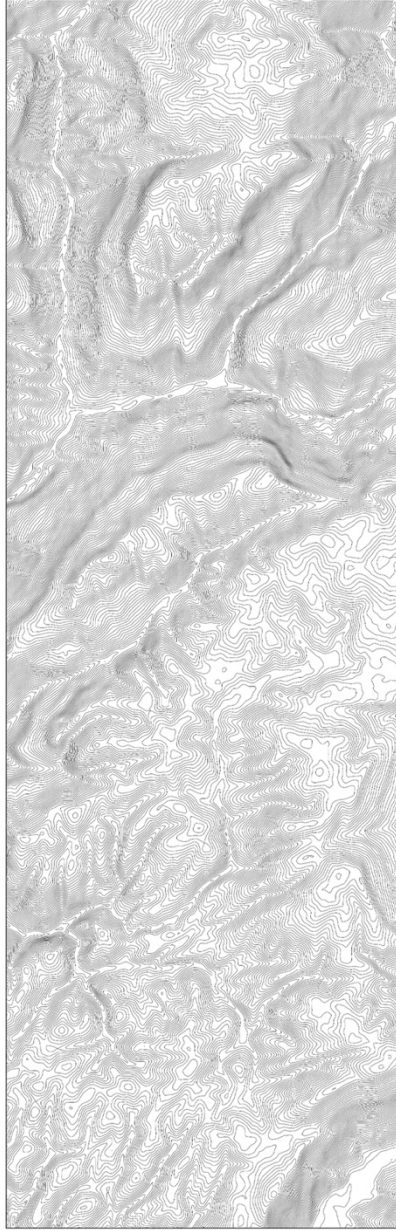

Drawing 1.2 (sequence) Nightrise at the intersection of nightwalking and slumber, sunset and sunrise, moonset and moonrise, moonlight, and urbanization.

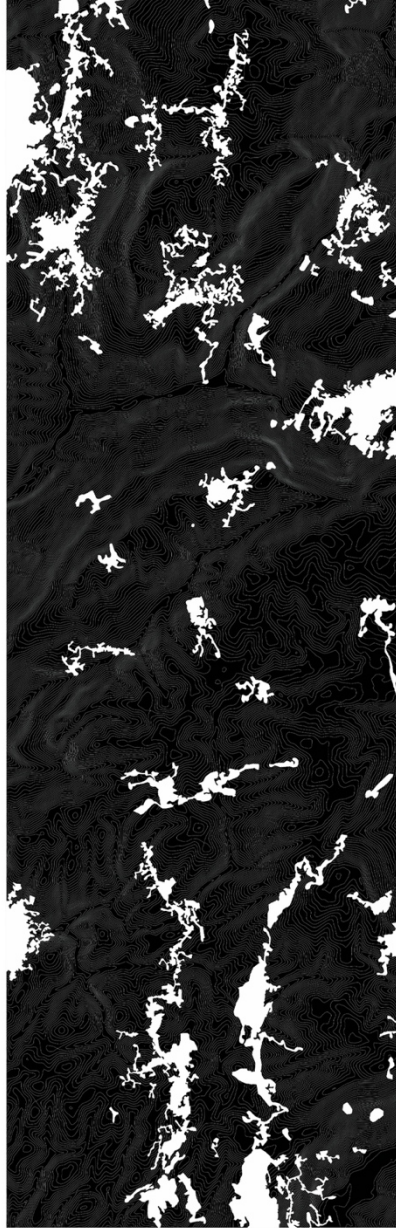

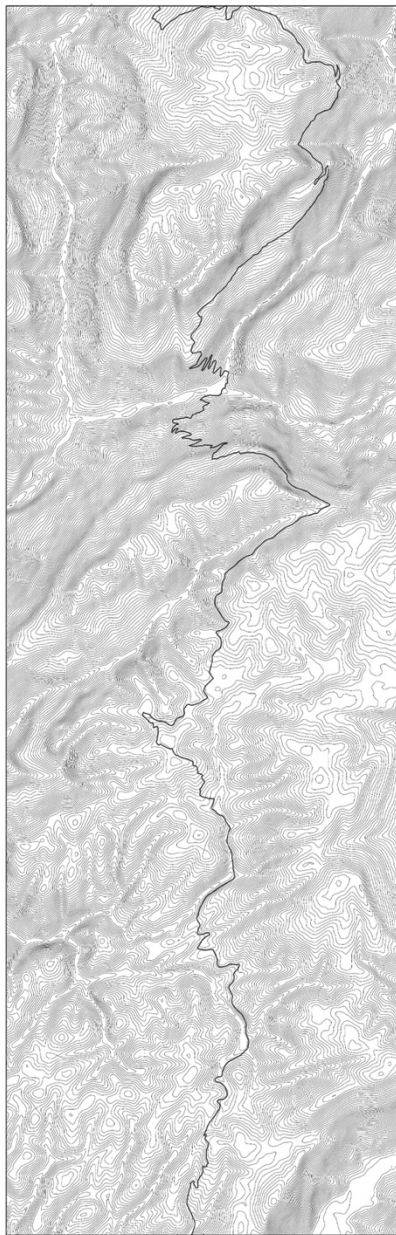

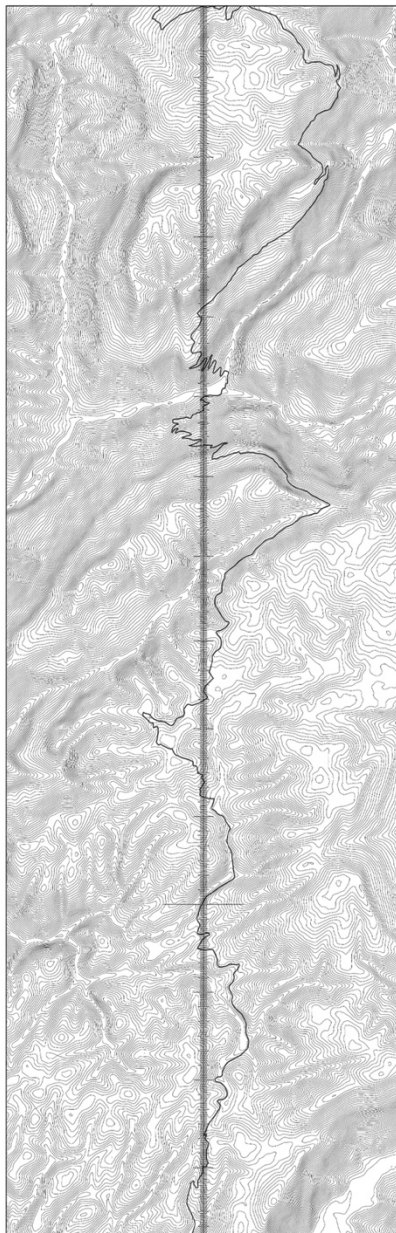

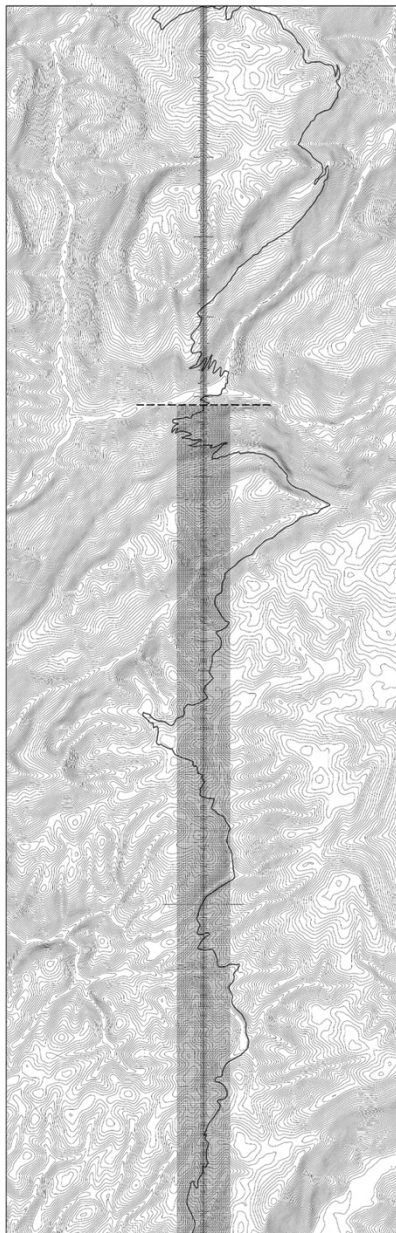

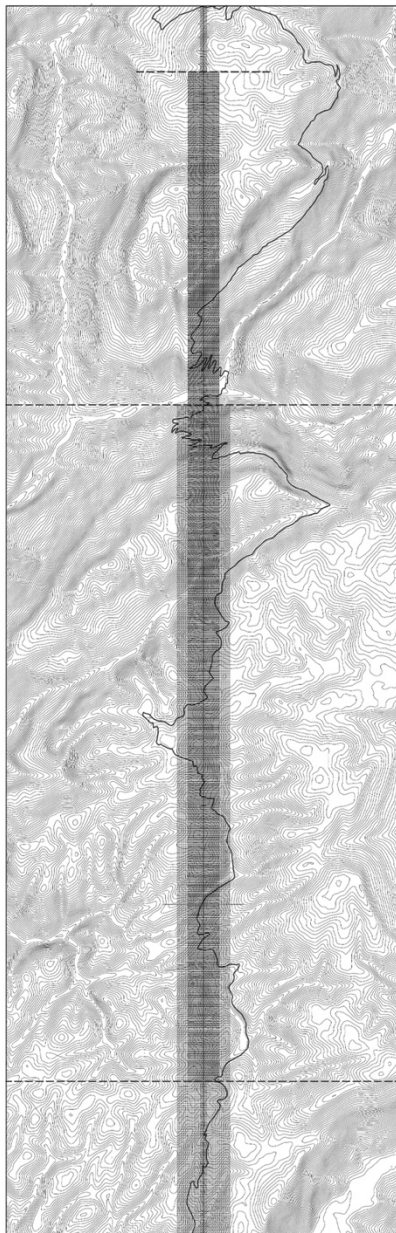

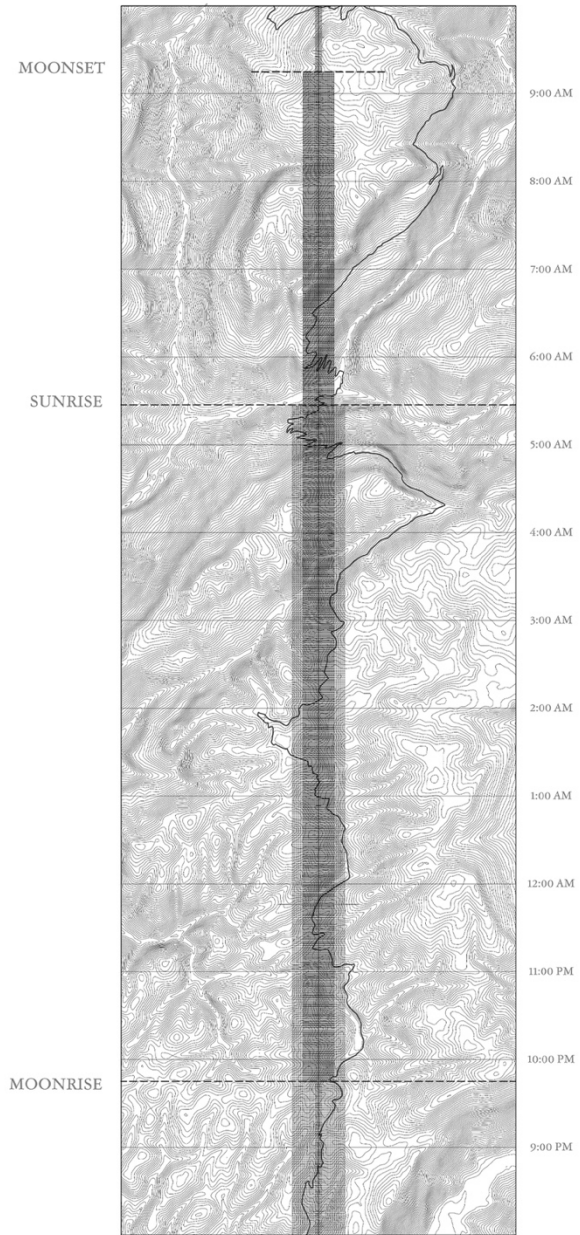

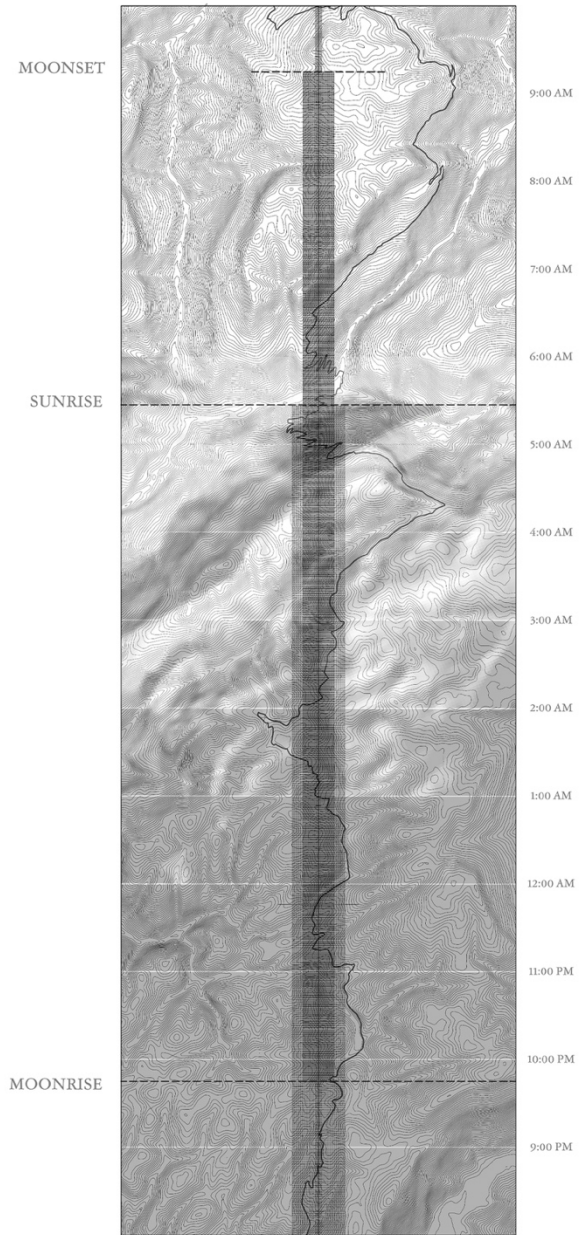

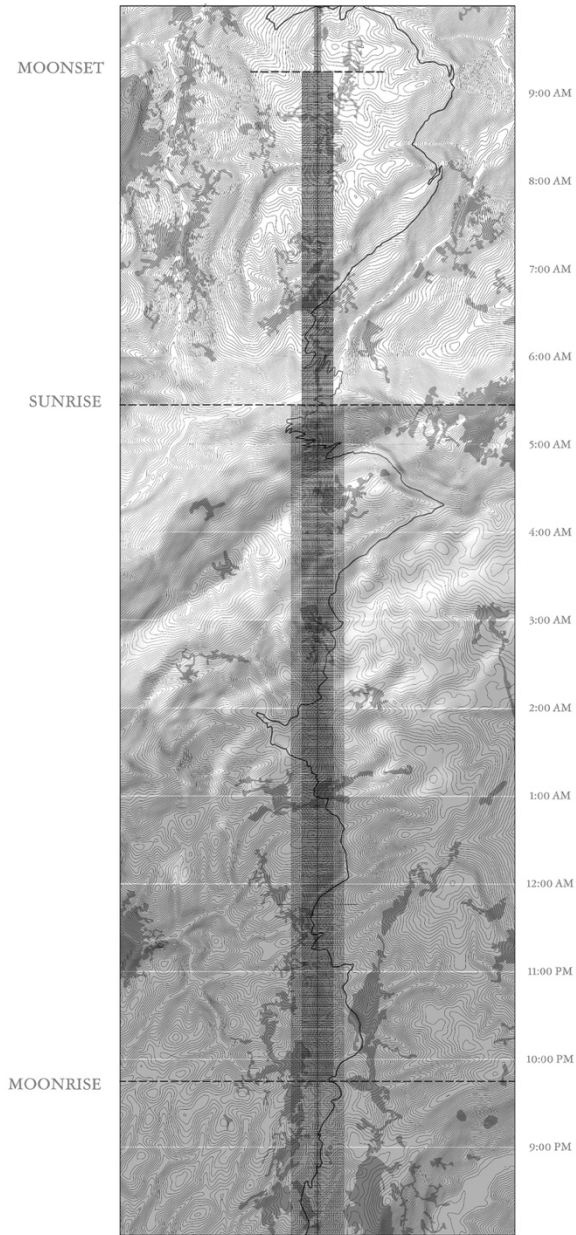

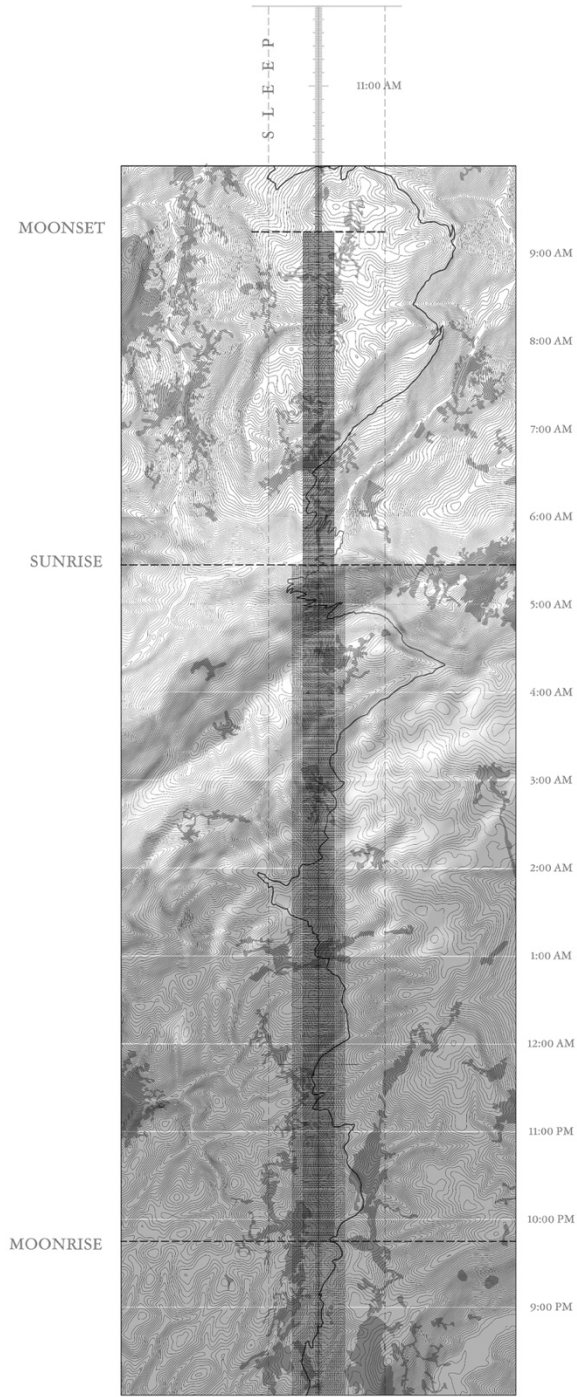

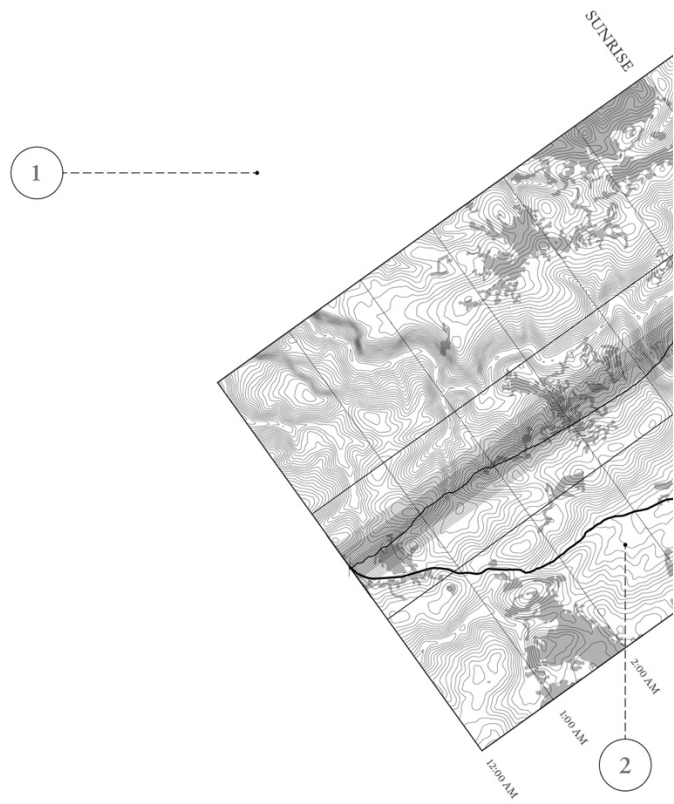

Drawing 1.3 (sequence) Mapping the twenty-six-night walk at Nightrise

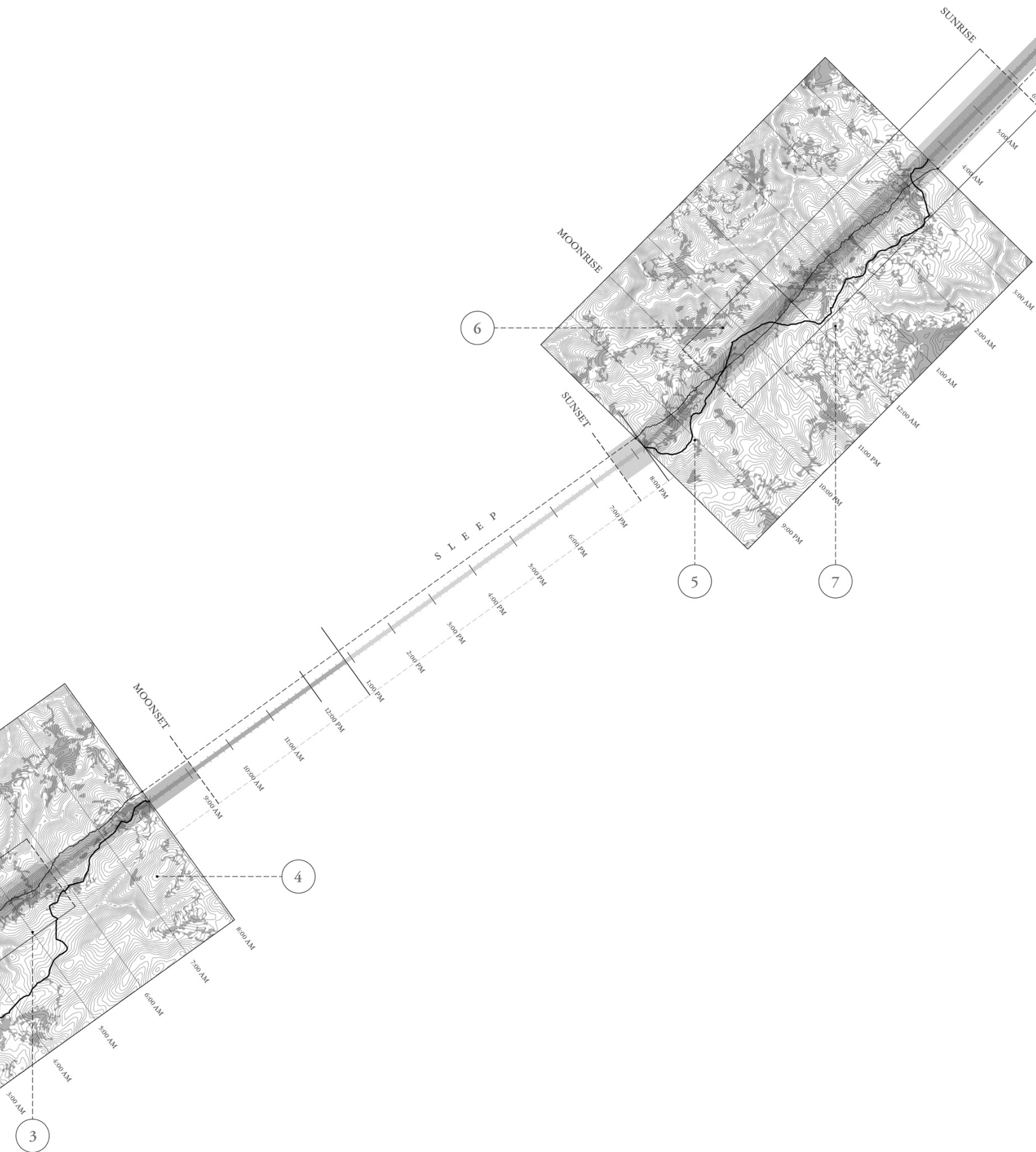

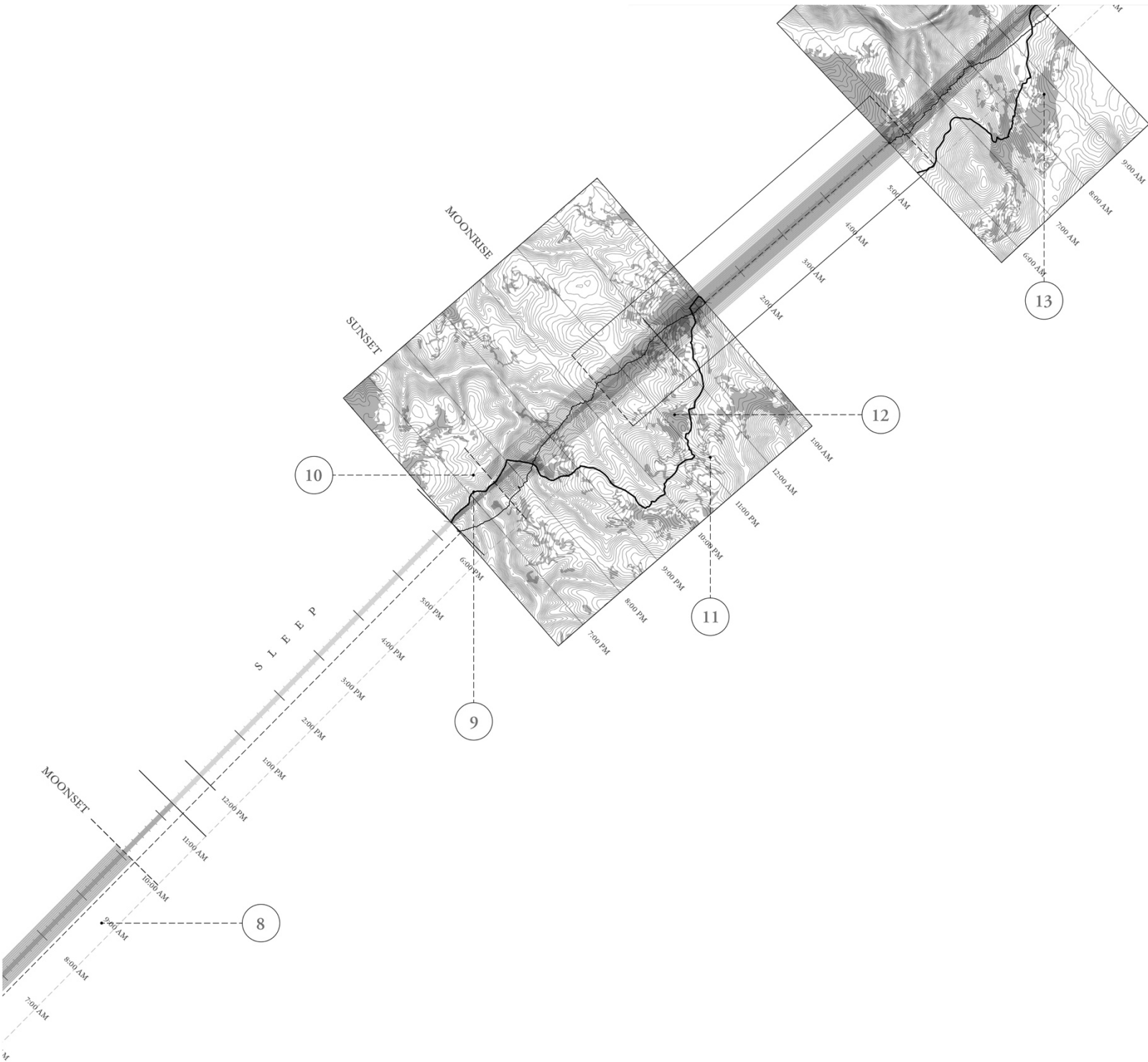

S L E E P

3:00 PM
2:00 PM
1:00 PM
12:00 PM
11:00 AM
10:00 AM
9:00 AM
8:00 AM

MOONSET

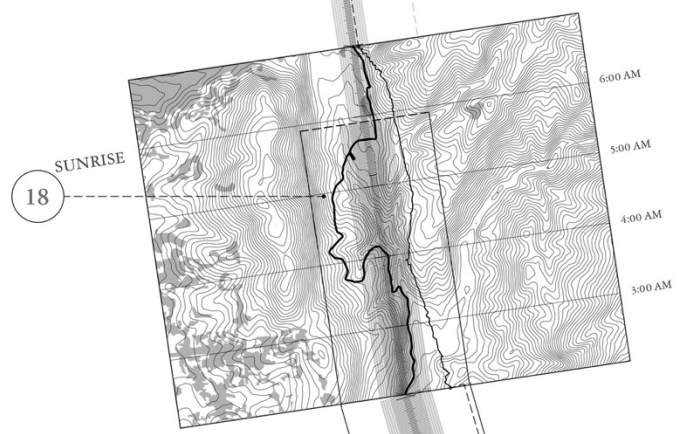

1:00 AM
12:00 AM
11:00 PM

16 MOONRISE

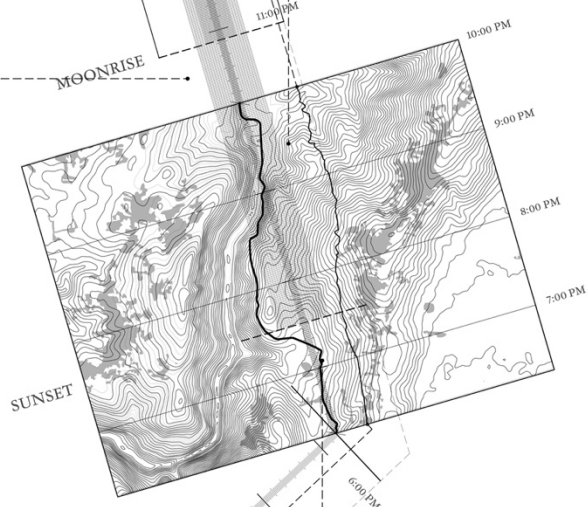

14

S L E E P

15

MOONSET

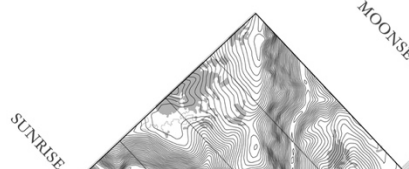

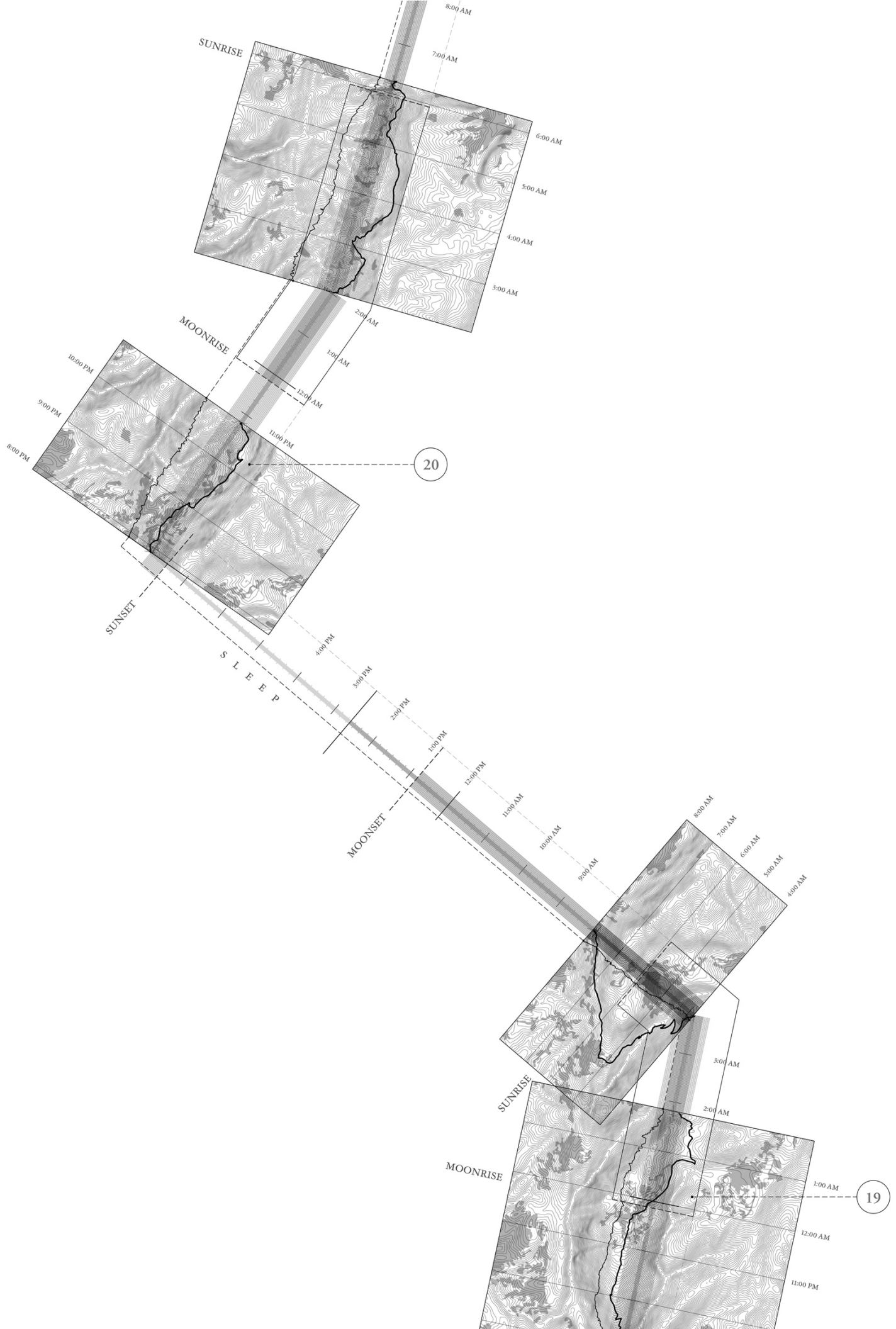

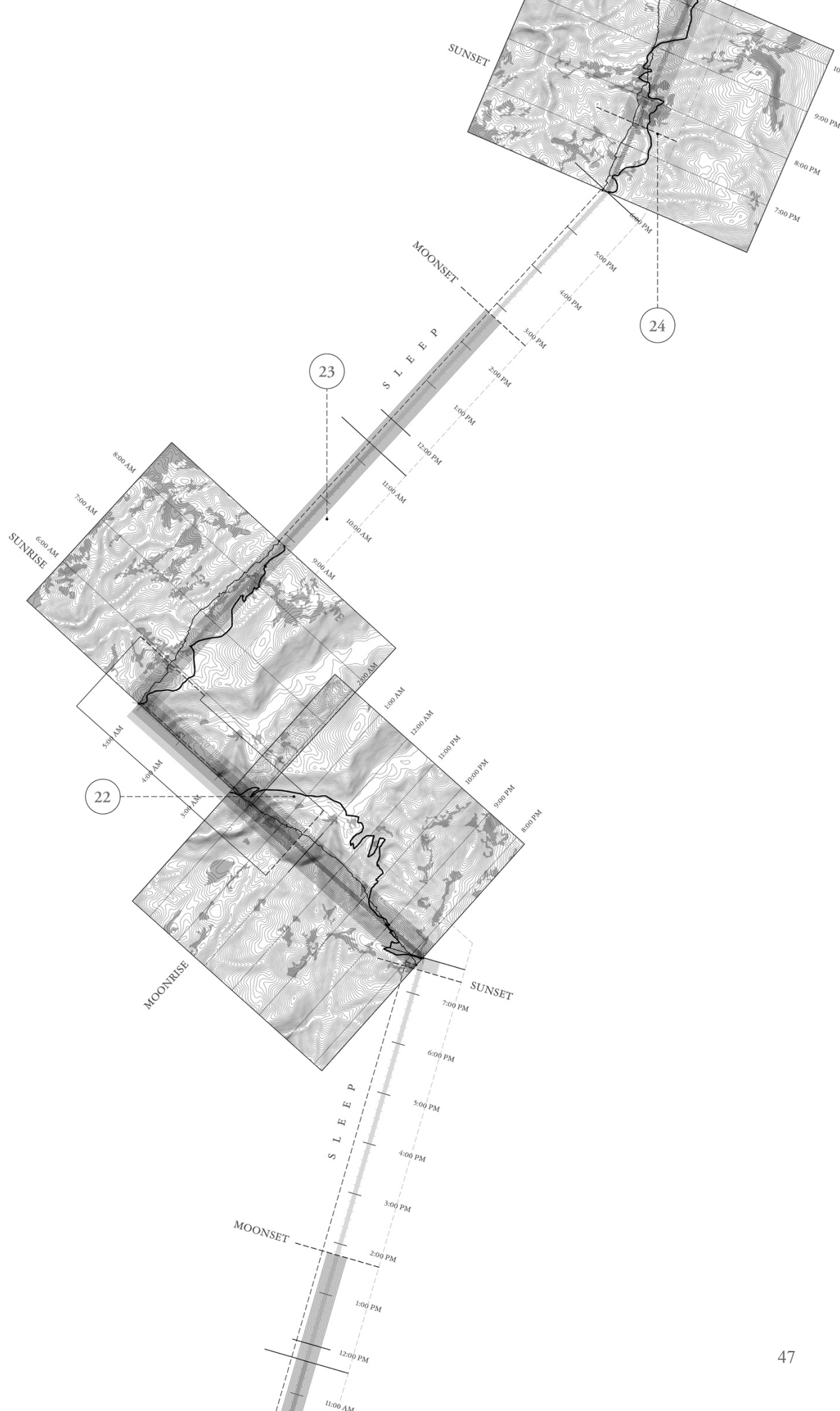

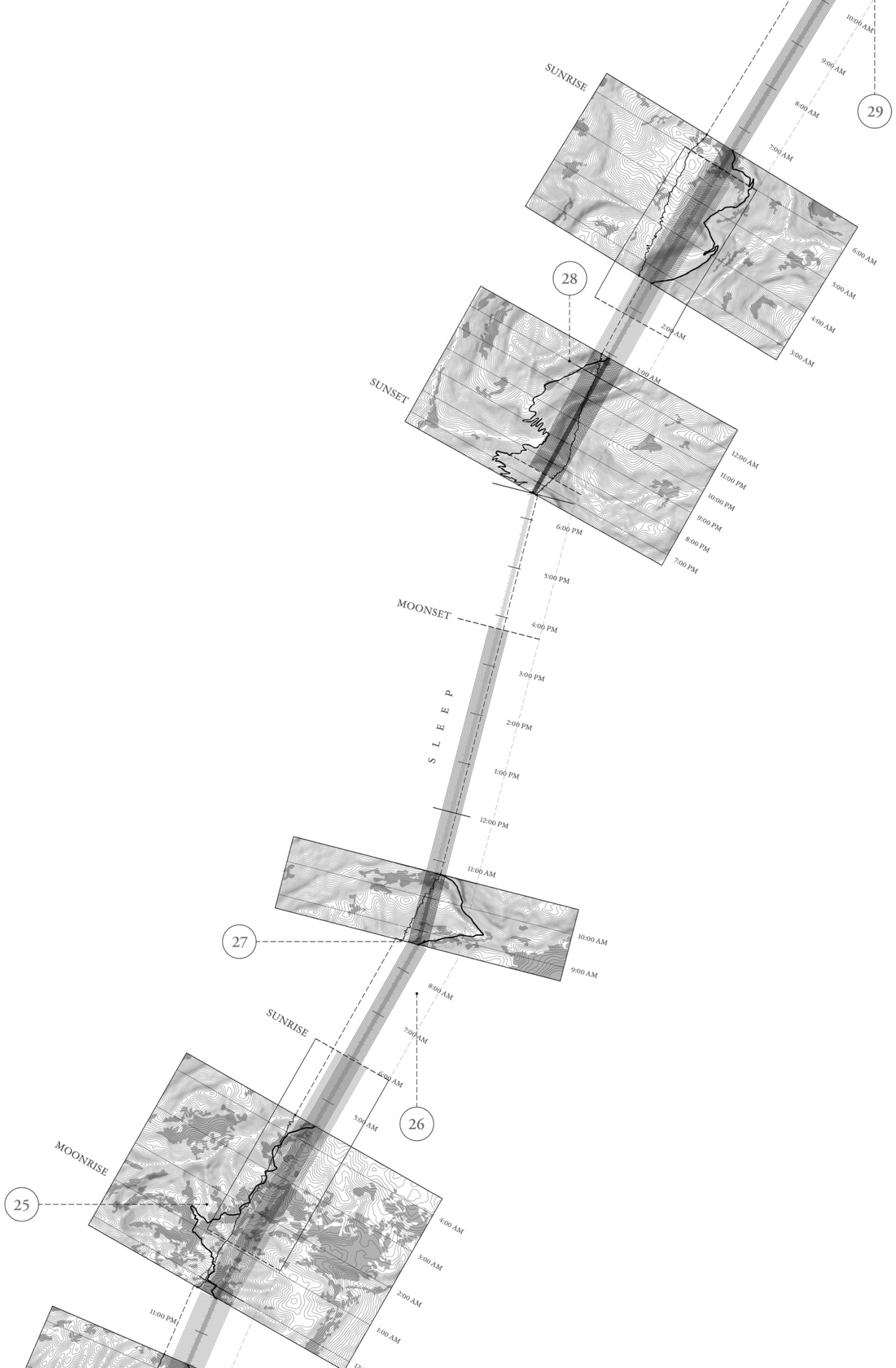

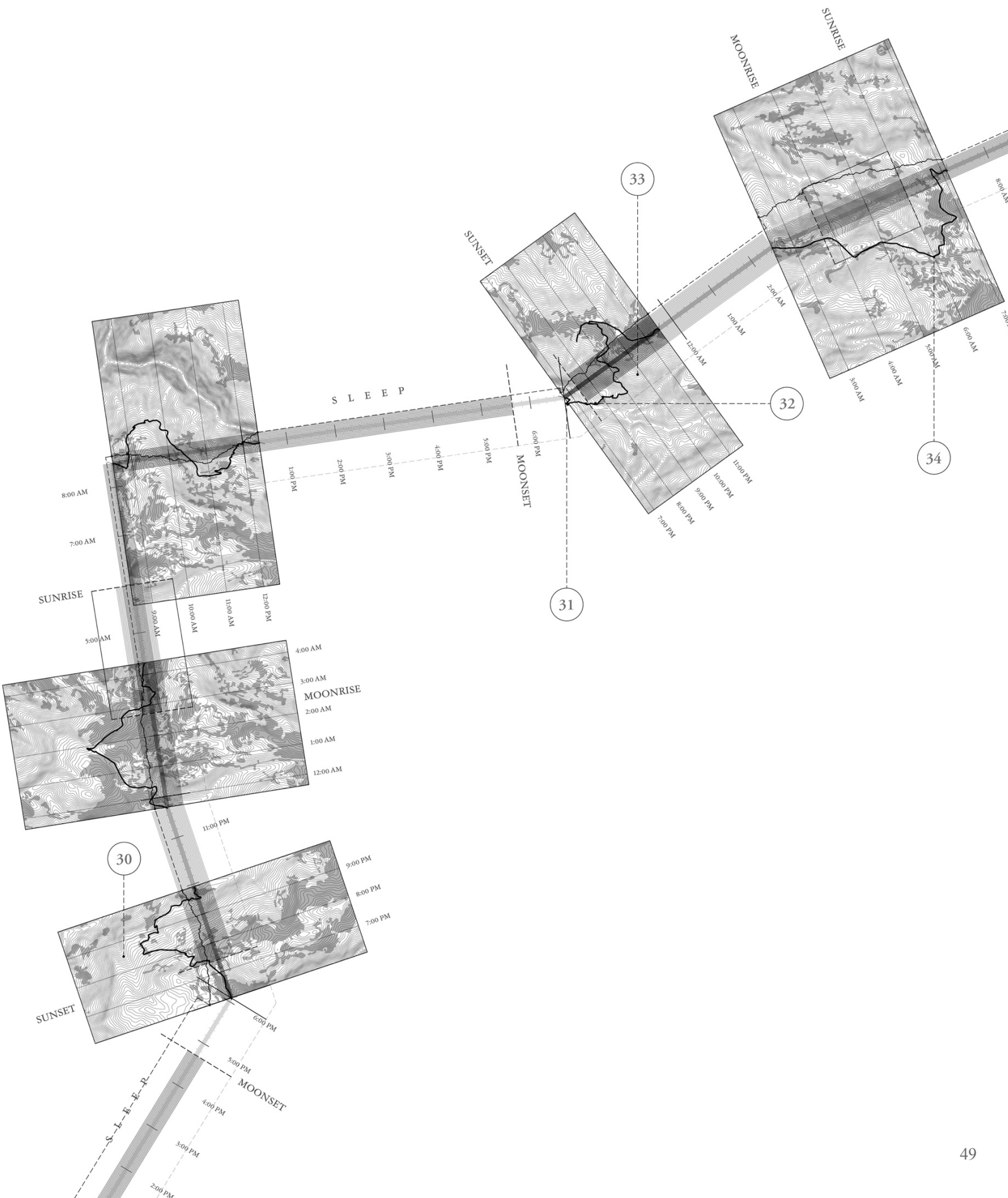

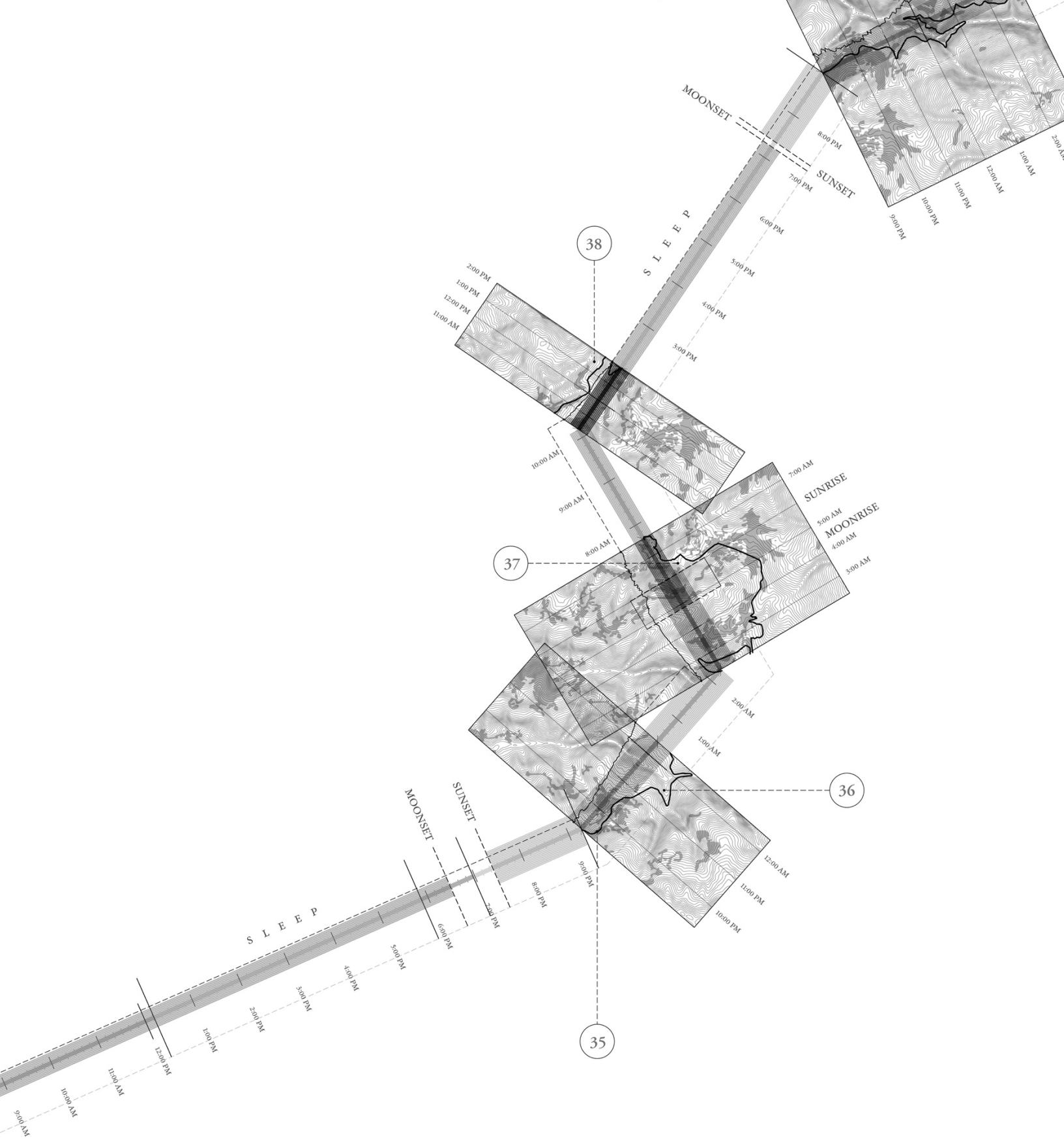

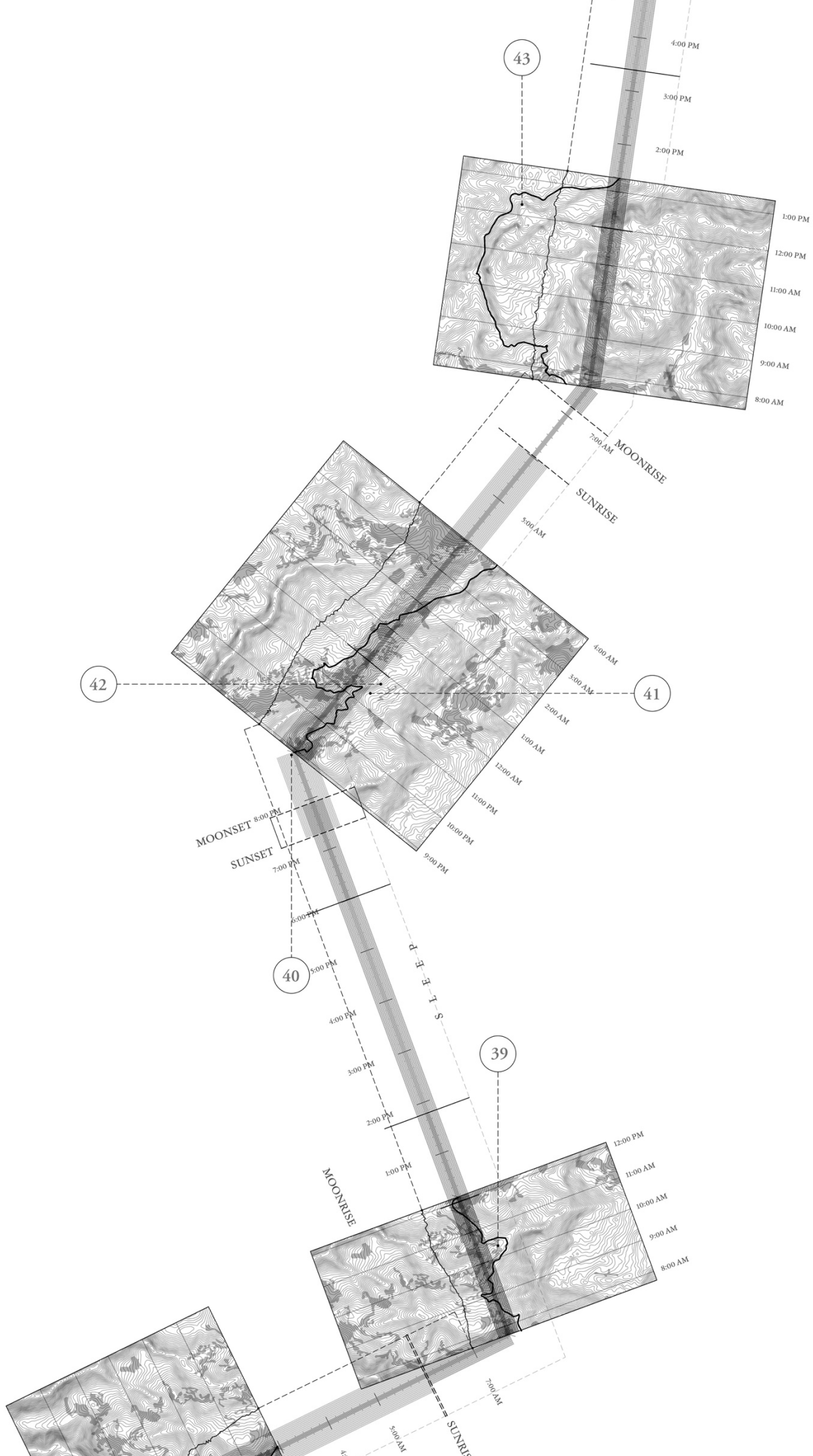

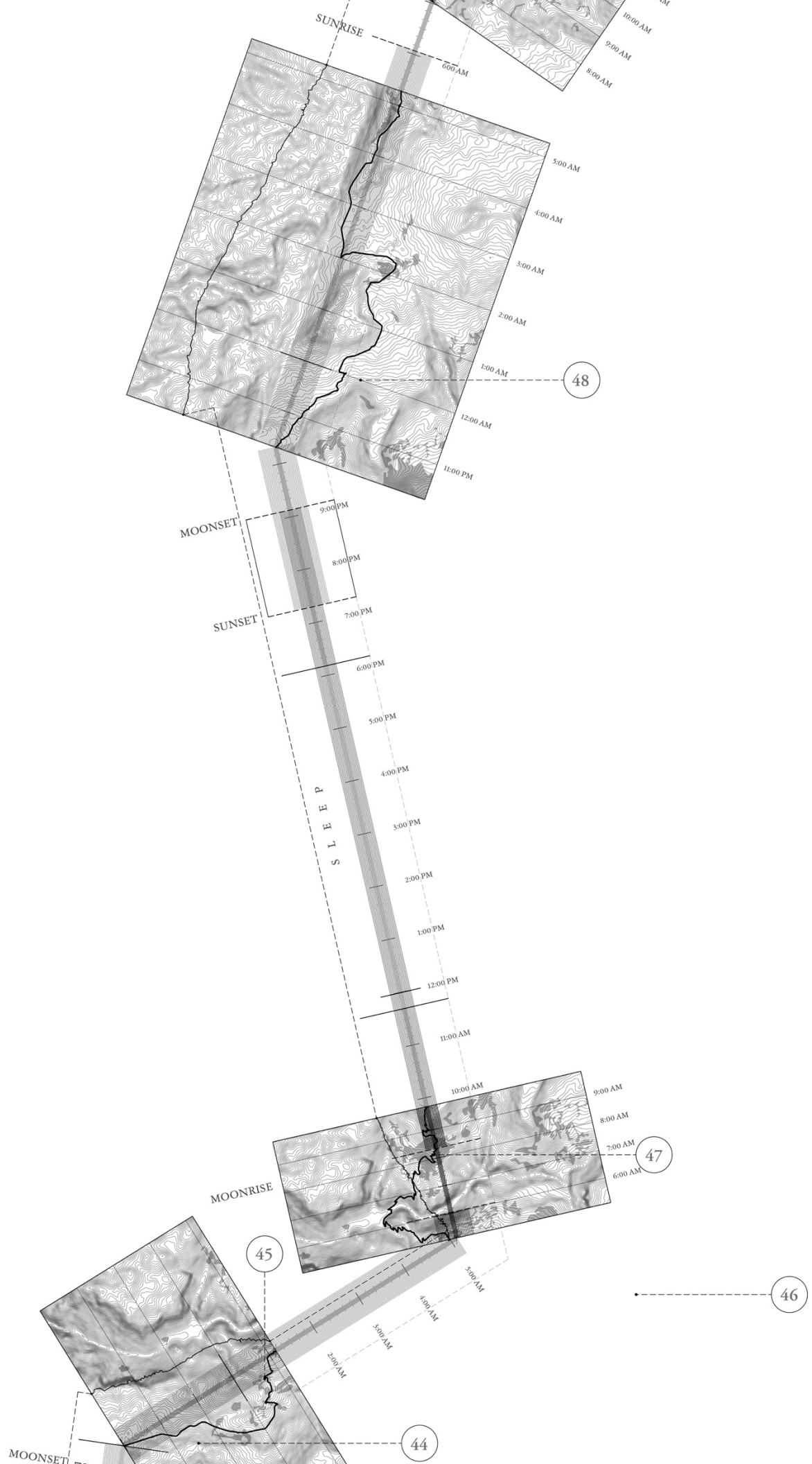

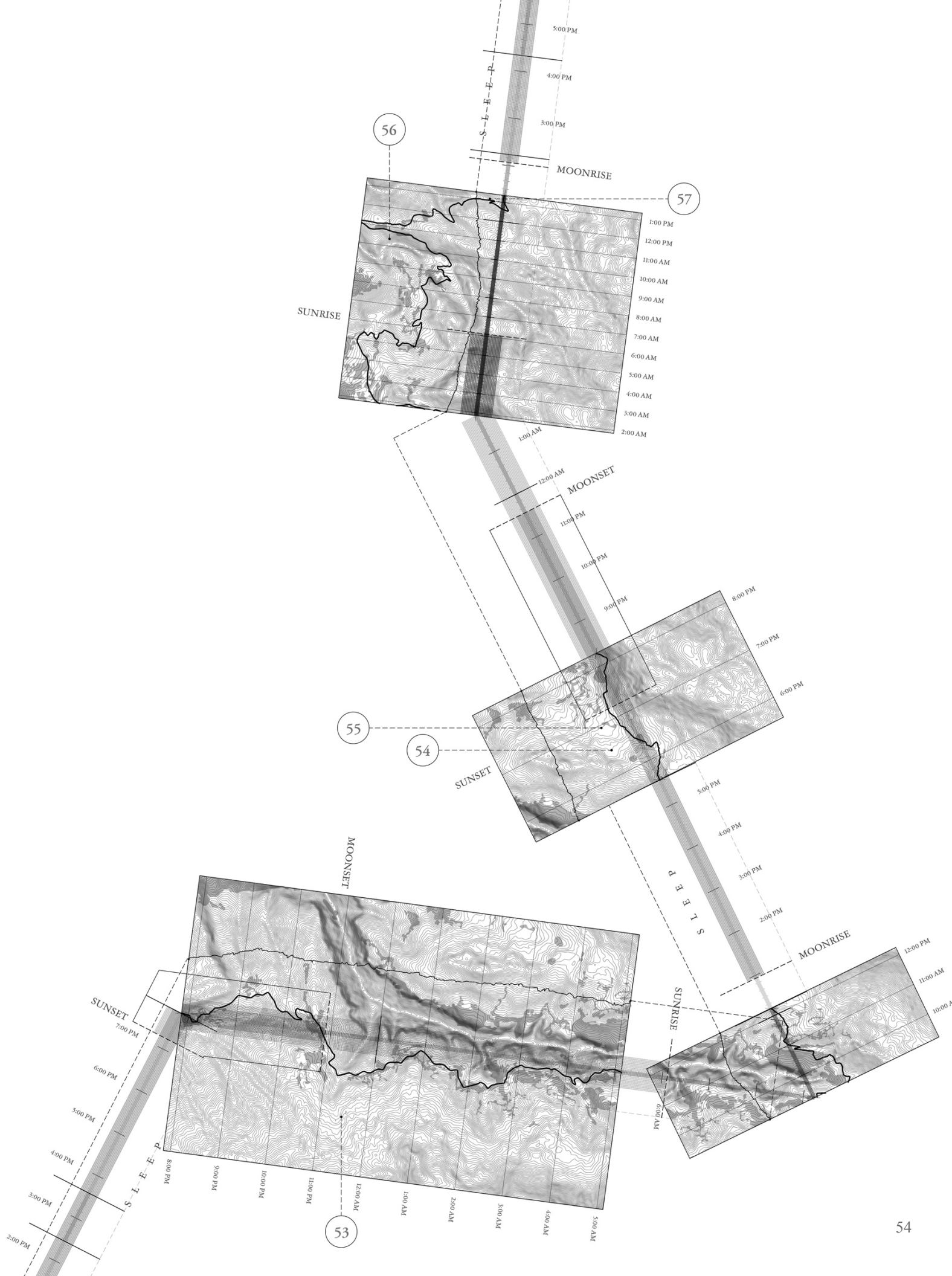

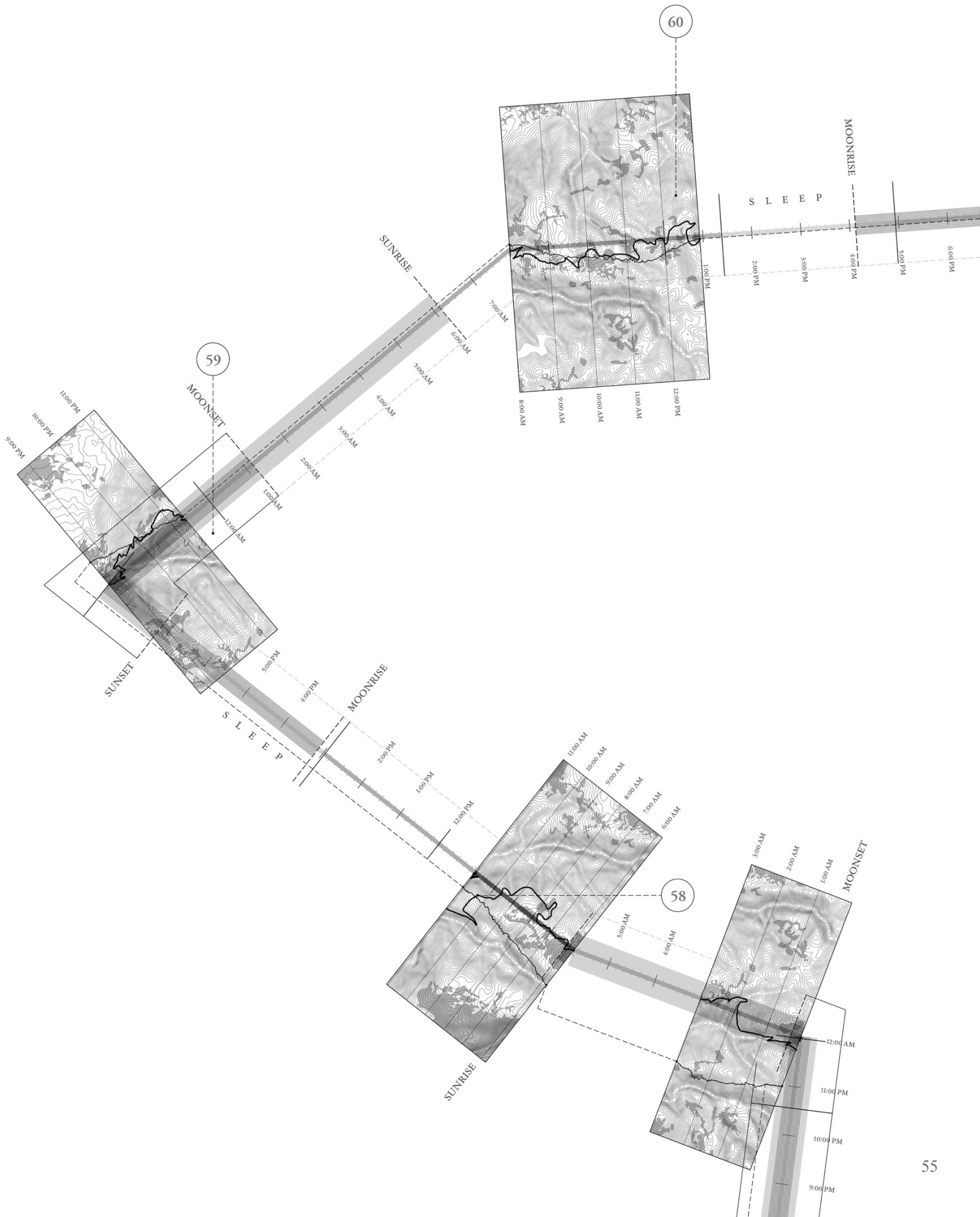

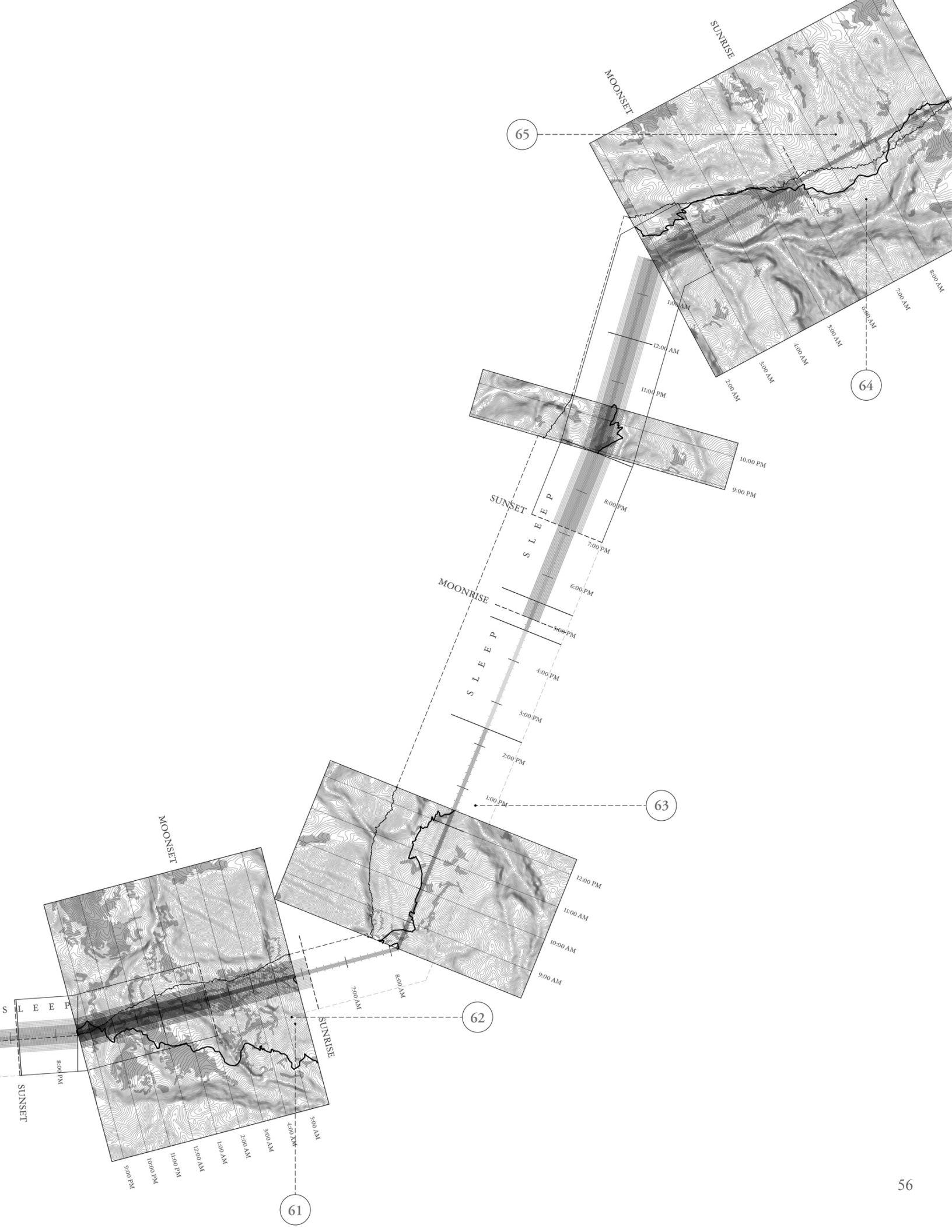

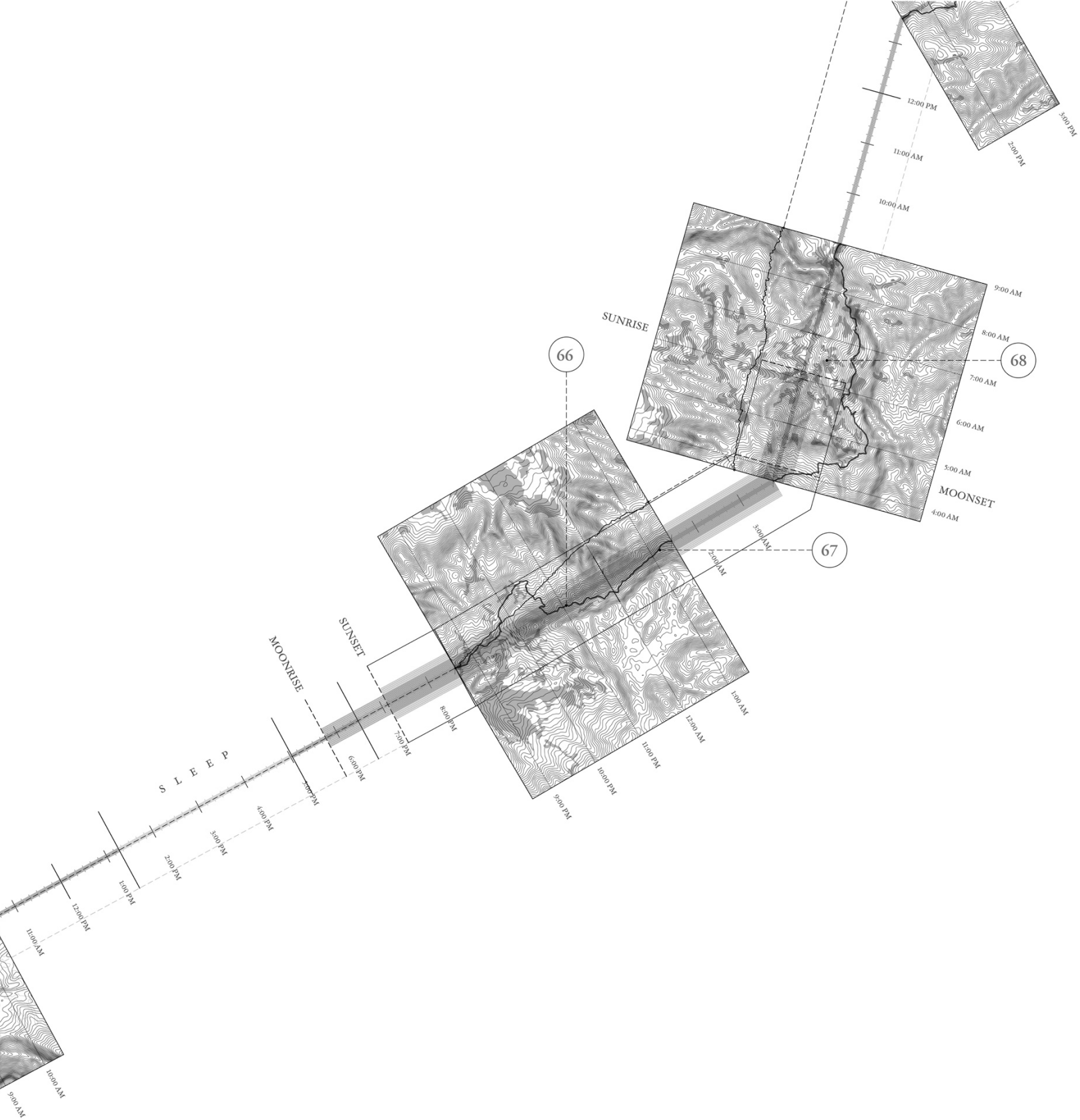

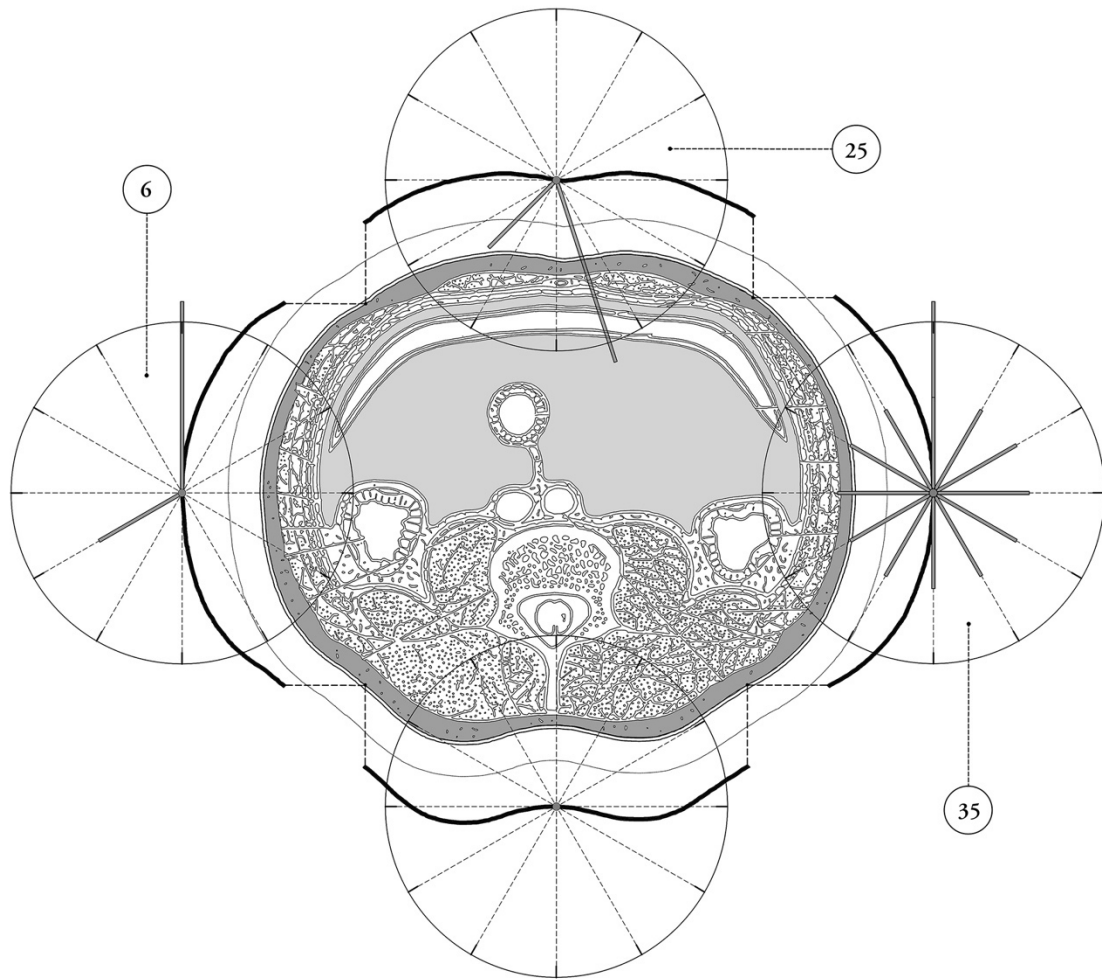

Drawing 1.4 Skins and their curfews. (6) Migrant Domestic Workers (Men), (35) Migrant Domestic Workers (Women), (25) Syrian Refugees. No curfew for Lebanese citizens.

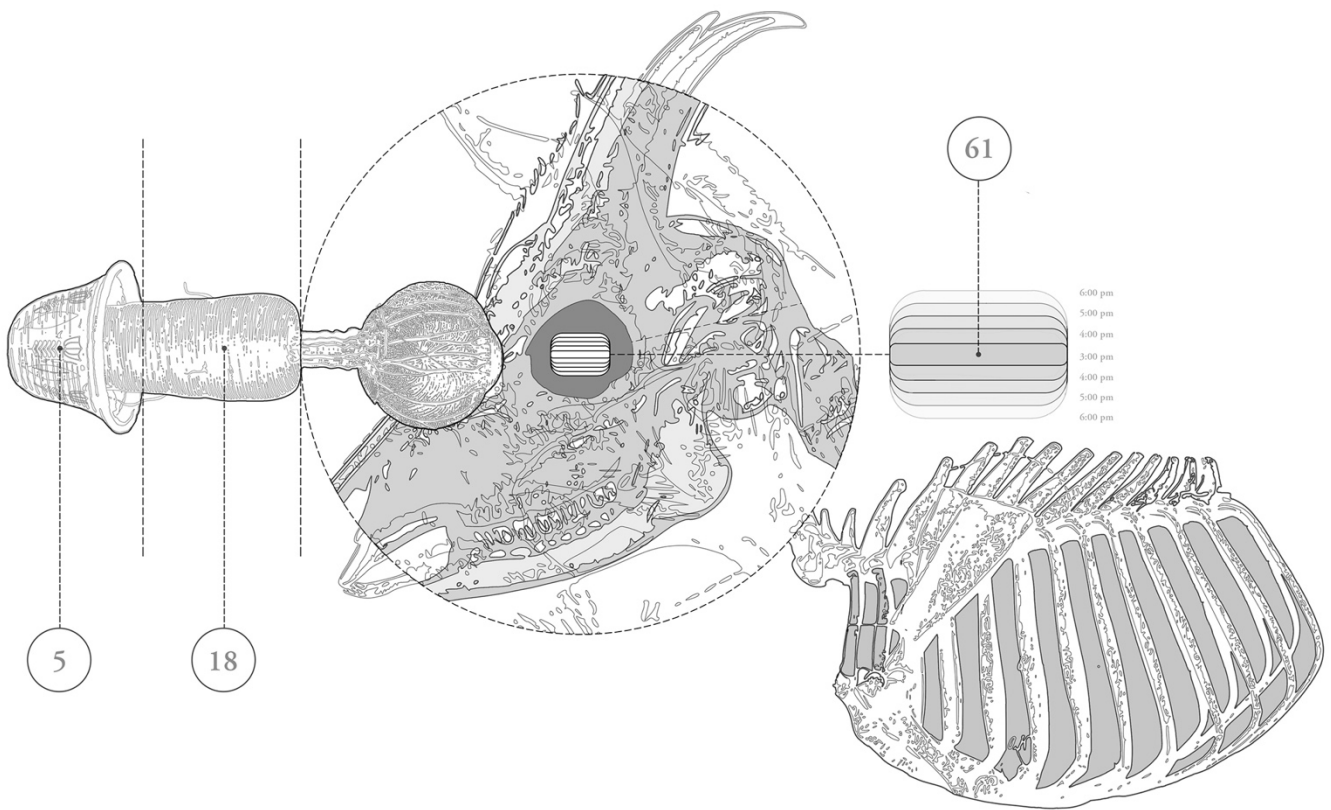

Drawing 1.5 The sheep's eye reveals itself as the shepherd's favorite clock.

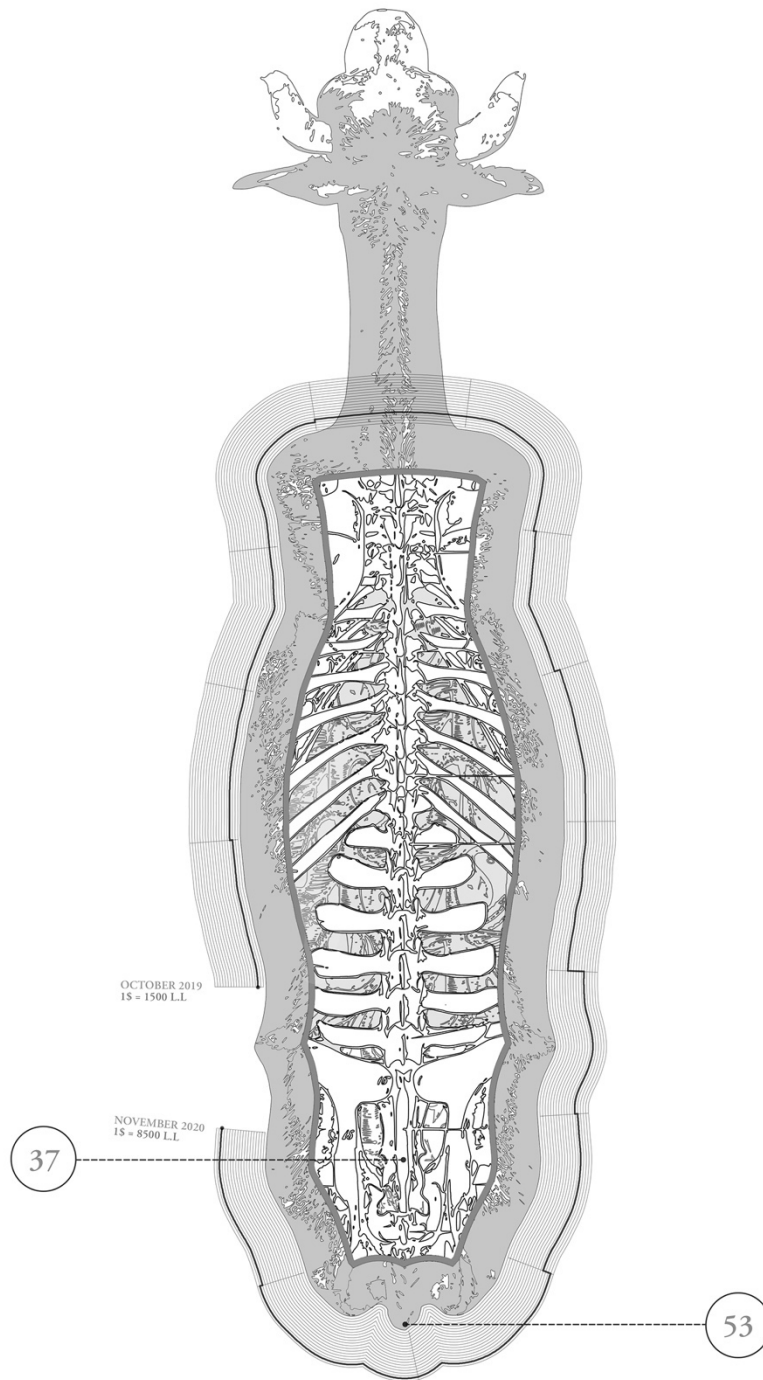

Drawing 1.6 The cow's inner body and the devaluation of the Lebanese Lira.



Image 1.1 (sequence) Assembling the stories. January 2021.



3. PART TWO: NIGHT SIX ONWARDS

a. THE PATH

“You know, I’ve been thinking about what we discussed last time you were here with the farmer, and I think I’ve got a few good ideas to share with you,” said the head of the Municipality of Taibeh. With an enthusiastic shake of my hand, he invited me into his office and offered me the chair opposite his own.

“There’s this old path that leads down to the river,” he said, motioning vaguely out the window, in the direction of the valley. “My grandparents, yours, all of our ancestors once walked it to collect their water for the day.” Such was the case for all villagers across Jabal ‘Amil, the mountain home to the Shi’is of what is now known as South Lebanon. Traces of the various paths stamped into the earth by those in search of water still crisscross the southern mountain to this day. A practice all but lost to history in the wake of the decades-long displacement caused by the Israeli invasion and subsequent occupation of 1982, walking *Tarik al-Nabr*, the old river path of Taibeh, only exists today in the memories and tall tales that are the village’s oral legacy.

“There’s a new road that’s been paved down the valley for vehicle access,” he elaborated. “It’s actually dug up right next to where the old path used to be.” The new road, he explained, facilitated tanker and truck access to the water pumping station installed on the river’s banks. “But no one likes to walk that!” he assured me. “That’s why I think you should do something with *Tarik al-Nabr*. There’s real cultural value there, even if you can’t use your car to make the trip down.”

Culture revitalization projects were popular with the municipality these days. Their latest intervention, a nature reserve on the mountaintop just outside the valley, had recently acquired enough funding for them to begin planting trees. But where the municipal head of Taibeh spoke of the river path and the mountain reserve as two distinct projects [Drawing 2.1], the possibility of intersecting the two quickly became clear [Drawing 2.2]. It was in that very meeting that I began to question what an extension of the old footpath, from the river to the mountain and on to the village of Kafr Kila, could mean for the people of Taibeh [Drawings 2.3 and 2.4].

And though I myself did not have the answers at the time, the municipality still went forward with entrusting to me the legacy of a village I was almost wholly unfamiliar with. It seemed to be their way of putting me back in touch with the village of my family, something that, in hindsight, they were quite successful at.

“We’ll be able to fund parts of your project of course,” confirmed the municipal leader, referencing the finances and the various other donations they could pool together through the Jabal ‘Amil’s Union of Municipalities. Because local cultural activity in the South has long since been stifled by tensions at the border, the path through Taibeh, he explained, could potentially reactivate the landscape as a center for the learning and scholarly production its oral legacy tells us it once hosted. So excited was he by the prospect of a new path, that the municipal head had me promise I’d be back by summer to start implementing the project.

Six months would pass between that meeting and the next, but by then, I’d have a plan, and it would be named the Path of Nightrise. Presented to the municipality in Spring 2021, the project would honor the stories the people of Taibeh had all grown up with. And in its tribute to the night, the path would look to the work of Jorge Louis Borges. For it is his story of the Muslim painter Tafas from the *Chronicles of Bustos Domecq* that has come to inform the nature of this project, the most essential excerpt of which is as follows:

It was on that occasion, after informing me of his distant Muslim origins (his father had come to these shores rolled in a rug), that Tafas tried to make clear to me that he was driving with his easel. In the Koran, he explained, just as with the Jews of Junín Street, the painting of faces, of people, of features, of birds, of calves, and of other living beings is expressively forbidden. How was one to set brush and tube in motion without breaking Allah’s commandment? After much trial and error, Tafas struck the right key. A spokesman from the midland Province of Cordoba had implanted it in Tafas that to be innovative in any art one has clearly to demonstrate that one has, so to speak, mastered it and can follow the rules like any old maestro. To break the traditional molds is the trend of our present age, but the would-be artist must first prove that he knows these molds like the palm of his own hand. As Lumbeira rightly pointed out, let us consume all we can of the tradition in advance of casting it before swine. A truly wonderful person, Tafas took these sane words to his bosom and put them into practice in the following way: firstly, with photographic fidelity, he painted views of Buenos Aires (within a limited perimeter of the city) that copied hotels, cafés, newsstands, and statues. He never showed these pictures to anybody – not even to the inseparable friend with whom he shared many a stein of beer. Secondly, he erased them with bread dough and tap water.

Thirdly, he gave them a coat of shoe blacking, so that his little paintings came out completely blackened. He was scrupulous enough, however, to label each one of his hodgepodes, which were now all the same – jet black – with its correct title, so that on each canvas you could read “Café Tortoni” or “Newsstand with Postcards.”¹³

In the sections that follow, the ways of Tafas are drawn on to elucidate the relevance of nightrise to the design of the path. The sections are ordered according to how Tafas intervened upon his own work.

A. The first gesture: the photographic fidelity

In the same way that Tafas first reproduces scenes of Buenos Aires with utmost accuracy, I start by tracing the imprint of the path from *Tarik al-Nabr*, the old River Path, to the neighboring village of Kafr Kila. While the painter bases his depictions on the postcards that he collects and recreates with uncompromising precision, I look for qualities in the landscape that might prompt a direction of the journey. Passing through three distinct topographic conditions, the path strings together the steepest side of a hill that still bears the traces of *Tarik al-Nabr*, the valley floor, and the spur, ridge, summit, and shoulder of the adjacent mountain that separates the village of Taibeh from Kafr Kila. And so, in a Borgesian sense, if the remains of an abandoned footpath and the particularities of the natural terrain represent the postcards, then the single line made to connect them embodies Tafas’s canvas [Drawing 2.5].

B. The second gesture: the occlusion of visual primacy

The blackening of Tafas’s paintings occasions the physical erasure of the artifact, an act that finds its roots in the painter’s distant Muslim heritage. Borges makes clear that it is precisely the aniconism associated with Islam that ultimately inspired Tafas’s practice. The mention of Islam in this fiction, as Max Ubelaker Andrade suggests, presents a departure from its theological implications in a way that instead foregrounds the relationship between imagination and the prohibition of visual representation¹⁴. He writes, “Borges’s reimagined ‘Islam’ thus ceases to function as a ‘historical’

¹³ Jorge Luis Borges, Adolfo Bioy Casares, and H. Bustos Domecq, *Chronicles of Bustos Domecq*, 1st ed (New York: Dutton, 1976). 107

¹⁴ Max Ubelaker Andrade, *Borges: beyond the Visible* (Pennsylvania: Pennsylvania State University Press, 2019). 4

religion in any meaningful way so as to take on the characteristics of an allegorical mode of literary exploration related to the author's own ideas about visuality, iconicity, and interpretation."¹⁵ But not only does Tafas's canvas allude to Borges's interpretation of Islam, it also offers us a glimpse into the author's own relationship with blindness. Borges's loss of sight happened gradually over twelve years until it vanished completely before the publication of the *Chronicles of Bustos Domecq*, the collection that includes the story of Tafas. The artist's destruction of his own photographic fidelity, then, not only suggests a reconciliation with the absence of visuality, but also a recognition of the paradoxical link between imagination and nonrepresentation. And so the process of blackening the canvas, which echoes the steady onset of Borges's blindness, produces a tension between the compulsive reliance on visual delights and the more challenging project of imagining them into existence¹⁶. It is this relationship that inspires here the erasure of the unidirectional line connecting the old *Tarik al-Nabr* to the mountain. In the same way that Tafas relies on the gradual application of black shoe polish to transform his work, nightrise becomes a means through which the erasure of the path in Taibeh might be accomplished. But how exactly might nightrise, as a process of transformation, be made to resonate with Borges's slow journey inwards, toward a heightened sense of imagination?

Potential answers are scattered around the valleys and mountains that acquire new life at nightrise, scenes very much evocative of a Buenos Aires once cloaked in the unseen. From the first shadow that creeps across the landscape in early afternoon to the last one that dissipates at late morning, the landscape of Taibeh is swathed in the darkness of a tremendous veil that slips from west to east in its journey away from the brilliance of the sun. It is here that the distinction between shadow and night grows weak, for what is the shadow of the afternoon but a premonition of the night? And what is the shadow of the morning but its ultimate departure? Might the night itself simply be a single magnificent shadow, one greater and darker than what our eyes alone can appreciate? Nightrise understands the darkness of the night, not as a static condition meant to negate the vitality of the day, but as the culmination of an intricate transformation rich in both logic and activity. This is the ritual of the darkening sky, which has captivated civilizations since time immemorial, and has thus transformed the shadows on our earth from ocular manifestations into mythological, if not philosophical, beings. And so, in the same way that Tafas's black canvas is, perhaps, not black at all, but a shadow being capable of mirroring one's own imagination, the erasure of the path's single direction allows for the existence

¹⁵ Ibid., 23

¹⁶ Ibid., 10

of countless other journeys. Each is, at once, a reflection of the night and of the visitor's relationship with the village.

But how can nightrise choreograph this erasure across Taibeh? And how can it do so in a way that captures and celebrates the ritual of the unseen? Every day, in the early hours of the afternoon, nightrise blooms across the valley. It first appears east of the valley as two subtle pools of darkness [Drawing 2.6]. They stretch towards each other and then west across the river until [Drawings 2.7 and 2.8], like a veil, they are large enough to swathe the entire world in their shadow [Drawing 2.9]. But as the sun reappears over the horizon [Drawing 2.10], the veil that was unfurled across the world [Drawing 2.11], slips away once more [Drawing 2.12]. It glides across the landscape until the last of it dissipates into nothingness on the westernmost edge of the valley. The life and death of the veil is, of course, not arbitrary, but is prophesied and narrated by every hill and cavity from the valley to the mountain. The story of the veil, authored by the peculiarities of the landscape, unfolds every day with subtle alterations that either prolong or abbreviate its existence in the village. It is on the summer solstice that the veil experiences its shortest lifespan, but every new day after that, until the coming of the winter solstice, extends its life by minutes. And yet the movement of the veil around the path is obscured for most of the year. The dense cloud cover above the village forbids the sun from revealing its passing except in the summer months. This implies that our eyes can only follow the slow and inevitable erasure of the landscape when the veil is at its most vulnerable state, when its lifespan is far shorter than it is during any other month of the year. So how does this fragile erasure inspire the Path of Nightrise?

C. The third gesture: the labeling

Much like how Tafas names his paintings to evoke the essence, rather than the visual nature of his scenes, the Path of Nightrise hints at a potential directionality through unique markers without ever revealing a singular answer. To celebrate the ritual that is nightrise through the passing veil, the path draws on the potential of the unidirectional line to capture the transformations of the landscape around it. On the summer solstice and at monthly intervals over the rest of the season, I begin by marking the path with the landscape's shadows at every half hour, from the early afternoon to the late morning [Drawings 2.13 and 2.14]. Every outline of the veil intersects the path at specific points. These points indicate the exact hours when the shadows of the landscape cross the line of the path [Drawing 2.15]. And because these shadows follow the same movement across the valley on the same

day every year, the path itself transforms into a timepiece that is at its most precise during the summer months and grows more and more dysfunctional as the clouds obscure the sky during the other seasons. In so doing, the path becomes the timekeeper of nightrise; its hour marks are the points of intersection between the reference shadows and the line of the path, and its hour hand is the veil itself as it moves gradually across the landscape to indicate the hour of nightrise, just as does the rotating hand of a clock. When these marks exist, the line connecting them becomes irrelevant, for they owe their actuality to it in the same way that a building owes its existence to a scaffold. It was always meant to be erased. And while they hint at its original directionality, they learn to exist without it, without the procession it implies. As such, these imprints celebrate the spectacle of nightrise without forcing a direction onto the pilgrim, without specifying what is and what is not walkable [Drawing 2.16]. And they do so by introducing the visitors to the motion and sensitivity of the rising night. But what are these imprints? How do they exist on the path?

As abstract points, these temporal imprints require action that reifies them in the same way that the action of writing marks each of Tafas's canvases with its correct title. By transforming each of these points into a station, the Path of Nightrise not only relinquishes any attempt at unidirectionality, but also brings together a series of spaces that exist both independently and as moments part of a larger experience. In other words, these stations engage in the ritual of nightrise, firstly, by acting as temporal markers that both hint at the direction of the path and magnify the passage of time, and secondly, by carrying their own stories, all of which are rooted in the oral legacy of Taibeh, and the tales of its inhabitants. From the scale of a single column to the scale of a chamber, these stations rely on nightrise to awaken some of the village's most cherished and forgotten stories. These stories, as will be seen in the next chapters, have not simply slipped from the consciousness of the locals, but have been violently extracted and buried by those who see in Jabal 'Amil— and particularly in the Shi'is of the mountain— a threat to their religion or sovereignty.

But not only do these stations relate to the culture of the village, they also take into consideration the craftsmanship and skills of its locals. As was made clear in the conversation with the municipality, there is a deep sense of pride in the quality of construction in Taibeh. This is a testament to the expertise of many locals who left the village in search of better ways to handle concrete and woodwork, and who returned with a new range of possibilities. One such prospect is the use of glass as an aggregate in concrete, a practice that witnessed an unprecedented spike in the weeks following the explosion at the port of Beirut on August 4, 2020. Glass debris of various size and color is ground

and smoothed then spread across the wet surface of a concrete mixture. Once cured, the concrete surface is swept and polished. It is precisely this technique can be made to dialogue with the Path of Nightrise in a way that foregrounds the process of erasure at the scale of the individual stations, thus echoing the gradual disappearance of both the path and the landscape. Not only is each station labeled by the hour of nightrise to which it corresponds in relation to the movement of the great shadow, it also manifests another transformation that embeds within this veil another erasure: a shadow within shadow. This second transformation relies on the presence of the glass aggregate worked into the surfaces of every station. In fact, it is the fragmentation of every station into infinitely smaller components that gradates the entirety of the path in a way that also reflects the light of the moon and stars in a vision of the night that is as multifarious as it is layered. In other words, the landscape erases the path just as the path itself erases the stations via their own materiality.

The chapters that follow offer iterations of what exactly these stations might be. They explore how the history and memory of an entire people might be reanimated through the spectacle that is nightrise. The stations that together comprise the Path of Nightrise do not seek to ward off the night but embrace it. They understand darkness not as the absence of light, but as an extension of the day, one where the senses might be heightened, and the imagination unleashed. Sightlessness here is not equated with insufficiency, but with the power to activate the faculties of the mind in a way that might free it from the limitations imposed by the optical. With each station designed to embody key aspects of local oral tradition, they are made to exist with an awareness not only of their immediate context, but of their place on a greater path in the river valley of the mountain that is Jabal ‘Amil.



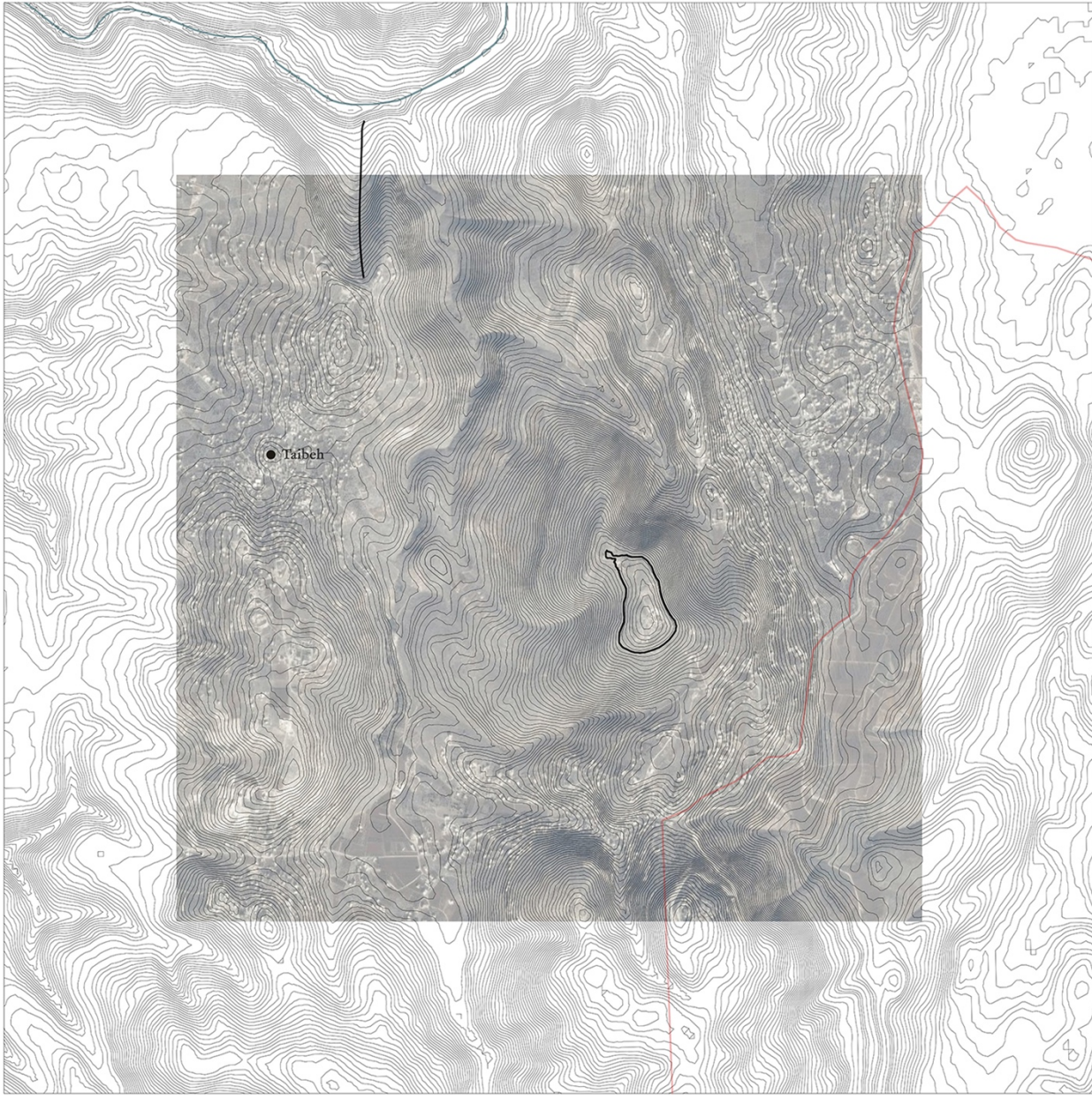

Drawing 2.1 *Tarik al-Nahr* and the mountaintop as two separate projects. The blue line represents the Litani River and the red line defines the southern border of Lebanon.

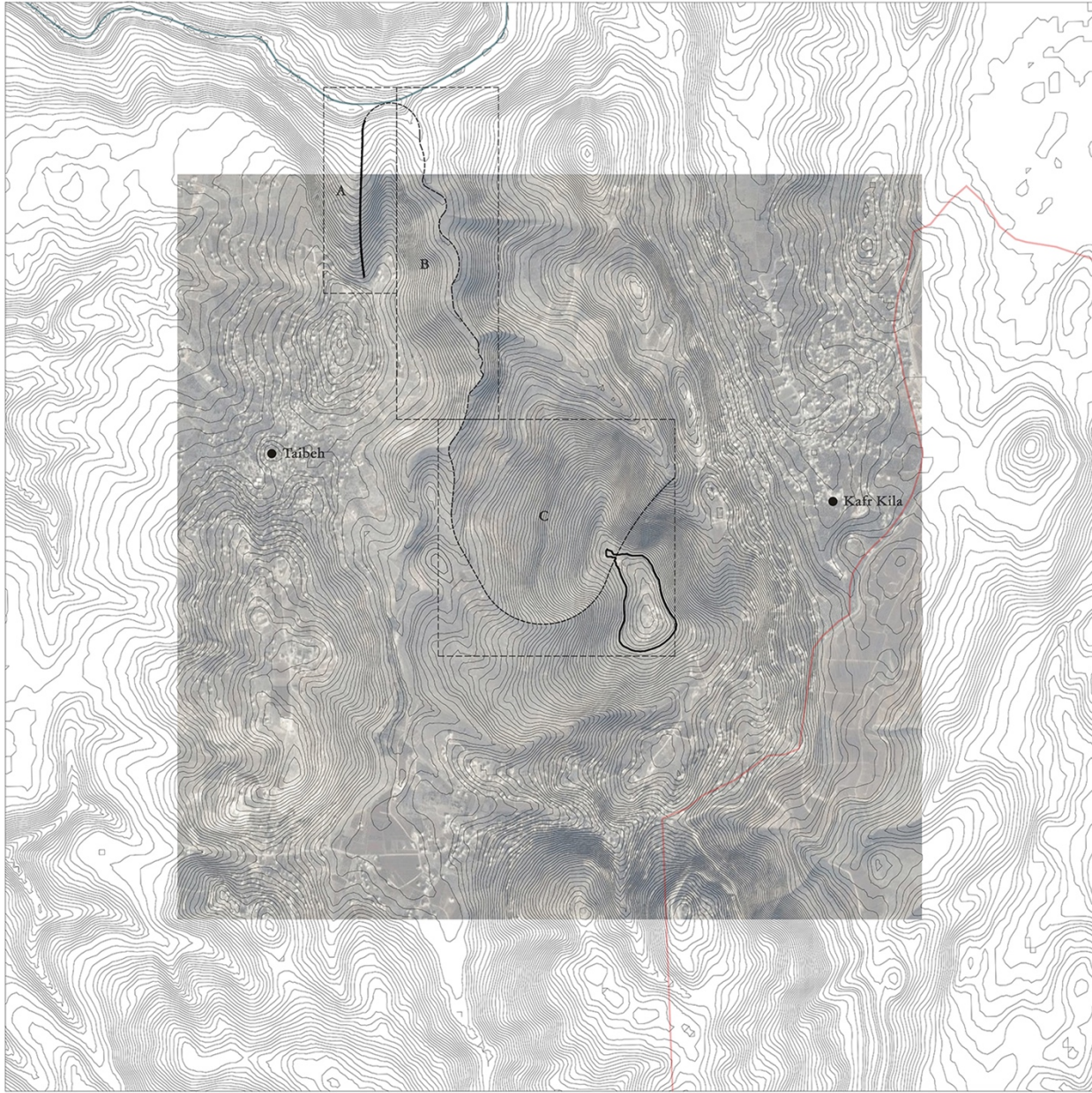

Drawing 2.2 Connecting *Tarik al-Nahr* to the neighboring village of Kafr Kila.

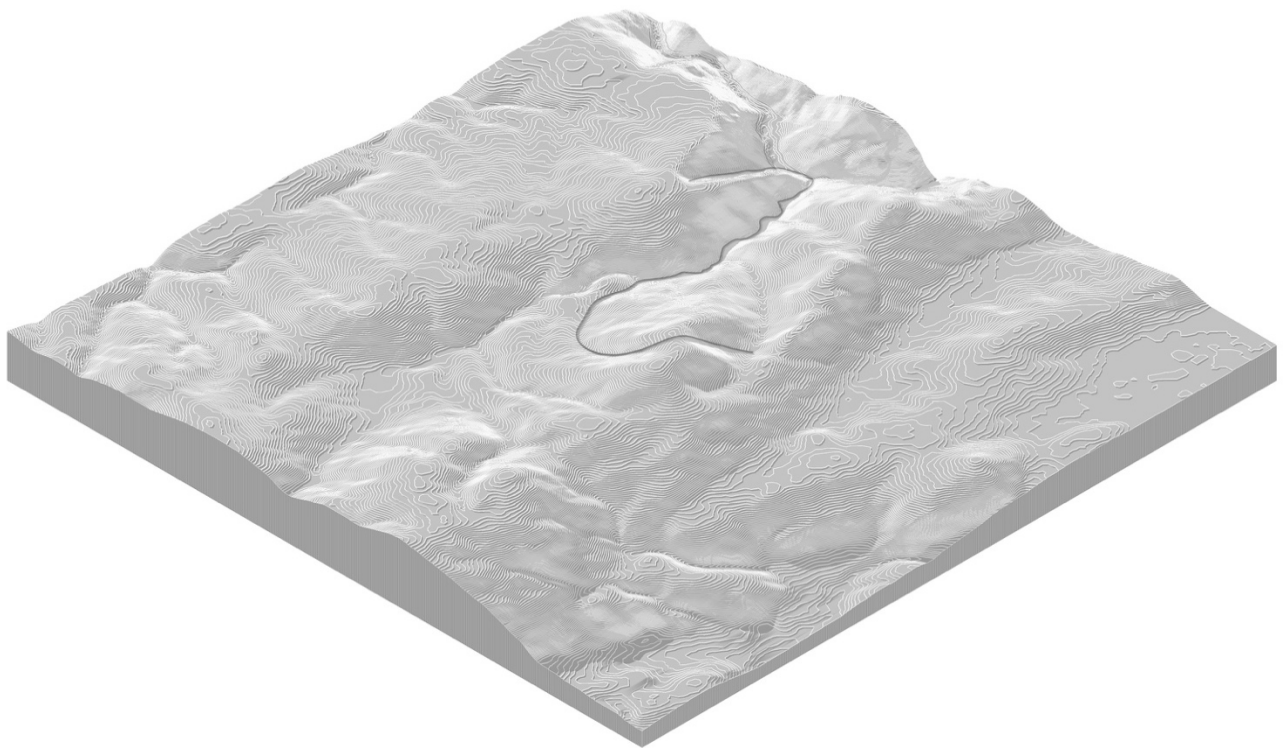

Drawing 2.3 The path as an imprint of the landscape.

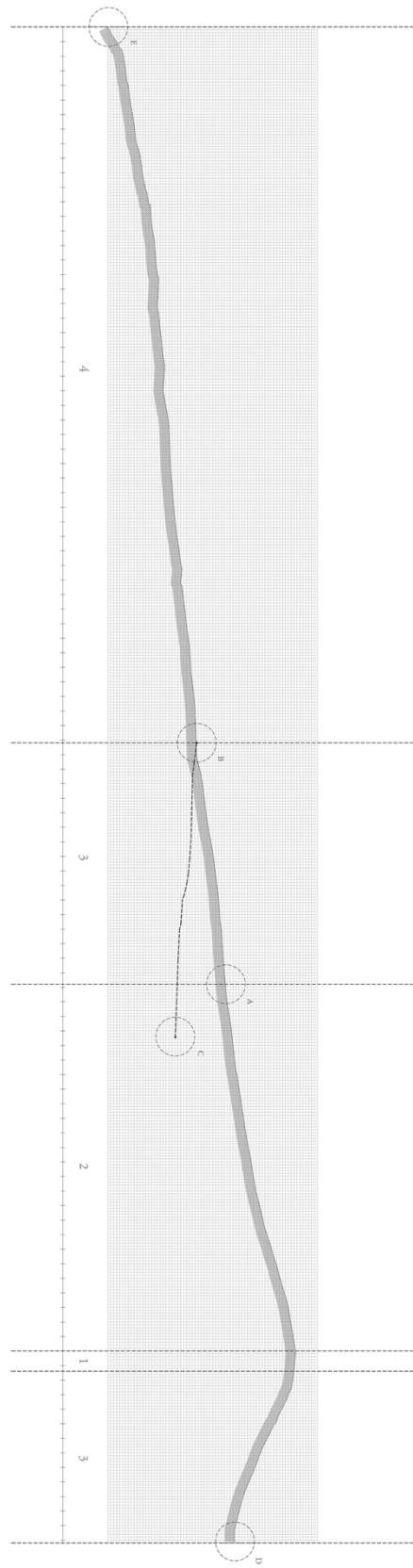

Drawing 2.4 Section from Kafr Kila (D) to the Litani River (E) passing by the path.



Drawing 2.6 First shadow of the early afternoon.



Drawing 2.7 Expansion of the veil of Nightrise.



Drawing 2.8 Expansion of the veil of Nightrise.



Drawing 2.9 Expansion of the veil of Nightrise.



Drawing 2.10 Expansion of the veil of Nightrise.



Drawing 2.11 Expansion of the veil of Nightrise.

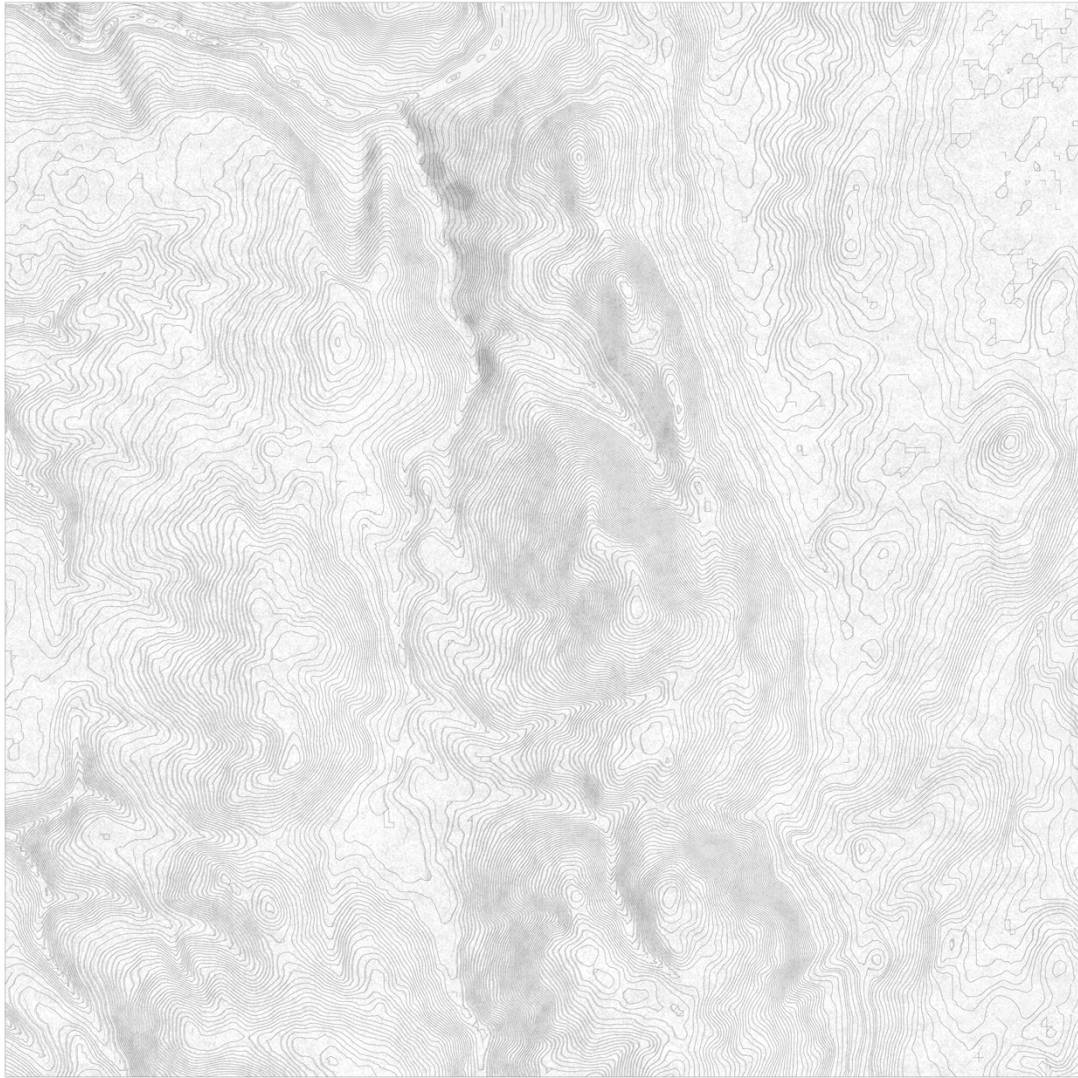

Drawing 2.12 Last shadow of the late morning.

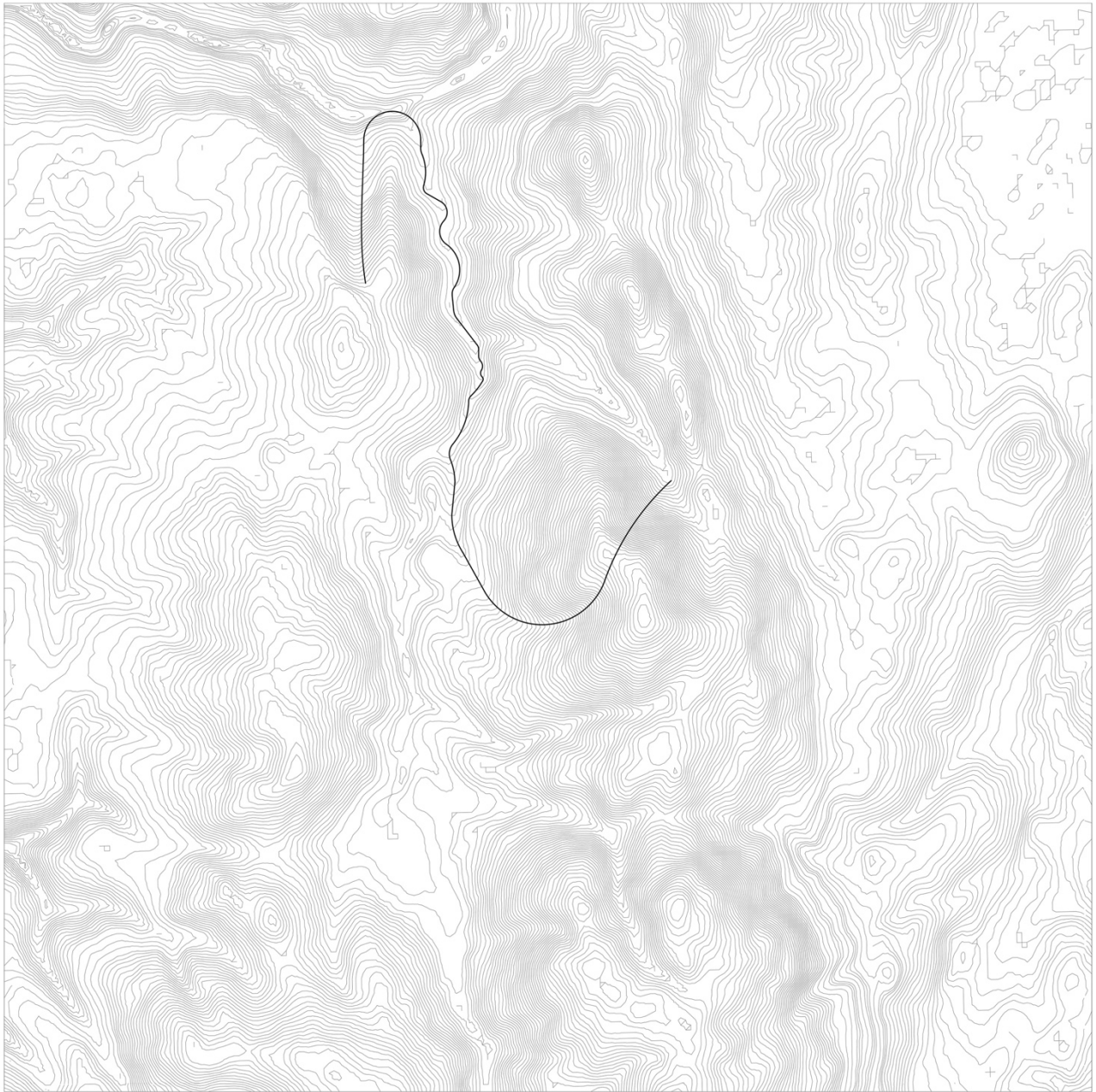

Drawing 2.5 The unidirectional line of the path.



Drawing 2.13 Afternoon summer shadows at 30-minute intervals.



Drawing 2.14 Morning summer shadows at 30-minute intervals.

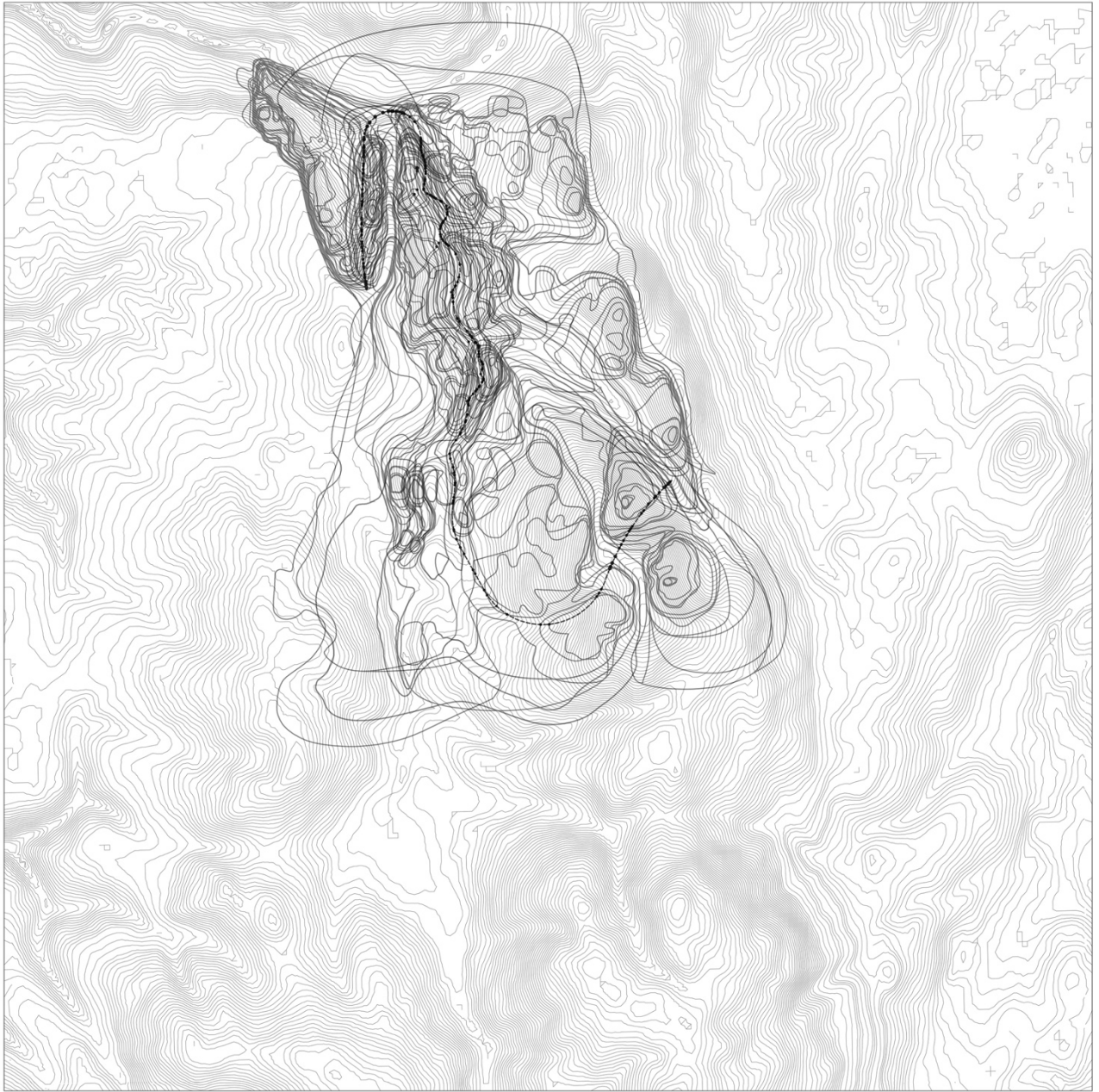

Drawing 2.15 Shadows intersecting the unidirectional line.

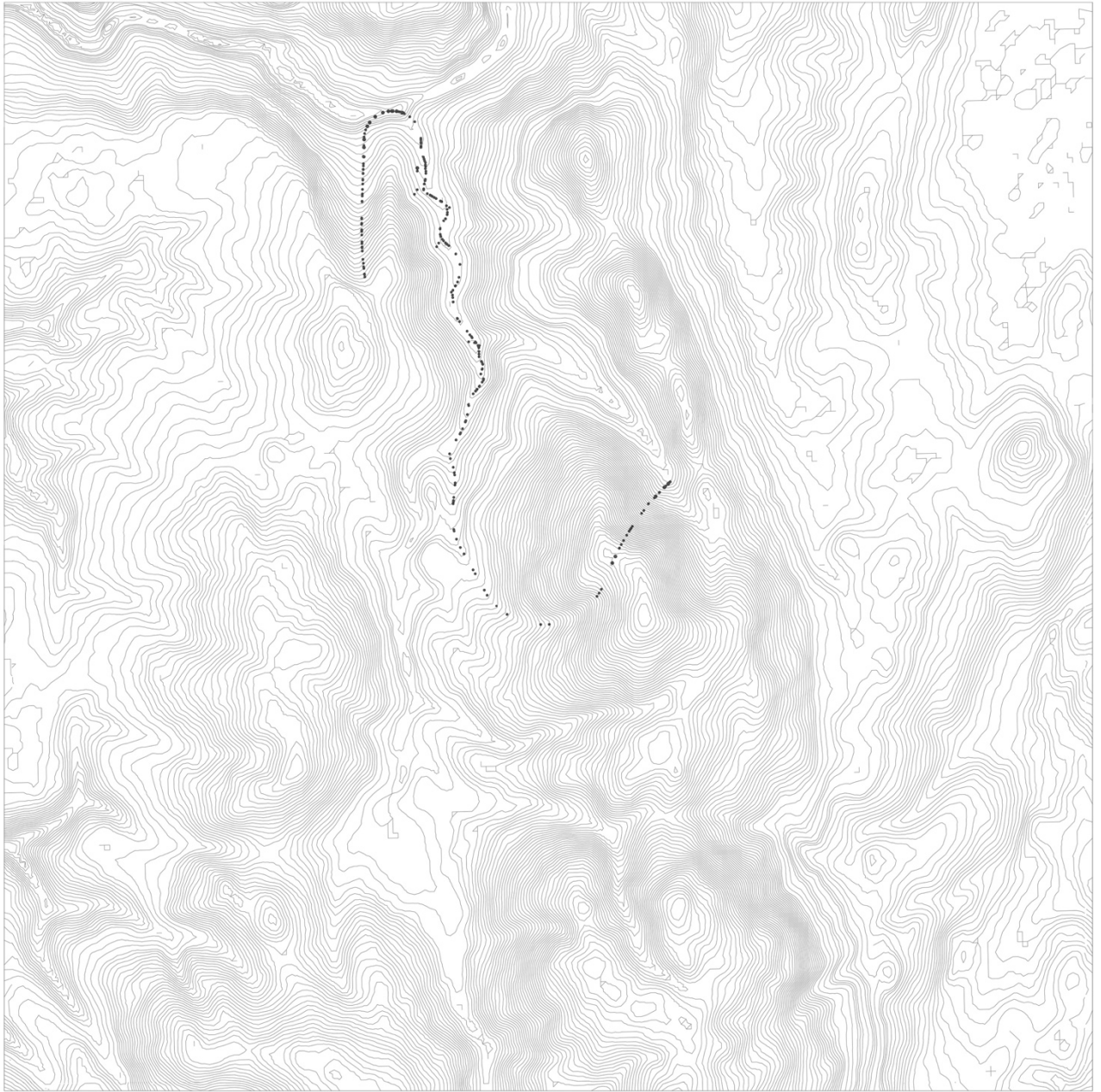

Drawing 2.16 The imprints of Nightrise.









b. UMM KAMIL

Umm Kamil, born Fatima Al-Assaad, appears in the village sky every night as a key figure of Taibeh's oral tradition. Mother to Kamil Bey Al-Assaad, Speaker of the Lebanese Parliament on several occasions between 1964 and 1984, Umm Kamil married into one of Jabal 'Amil's most powerful feudal era clans. As the uncontested *ẓu'ama*, the political leaders of the mountain between the 17th and 19th centuries, the Al-Assaad's authority was rooted in their official appointments as representatives in the Ottoman parliament¹⁷. These positions were, of course, not unrelated to their being the revered descendants of the Saghir family, a formidable clan said to have inherited the emirate of Jabal 'Amil in the 16th century¹⁸. Recognized as the rightful rulers of the mountain whose ancestors had died to protect the land and its faith¹⁹, the Al-Assaads came to symbolize the very meaning of martyrdom, the political and religious values that spoke to the essence of Shi'ism in Islam²⁰. And for the 'Amilis of the twentieth century, nobody embodied these tenets more defiantly than Kamil Bey Al-Assaad's namesake, his grandfather and the representative of Vilayet Beirut in the Ottoman government²¹. Tamara Chalabi writes:

People saw his lineage as a symbolic projection of the Shi'i notion of their history as one of struggle and martyrdom in the face of injustice, the life and death of the imams being the confirmation for this history of struggle. According to Shi'i legacy, all of Ahl al-Bayt, the descendants of the Prophet through his daughter Fatima and Ali bin Abi Talib, were either killed or poisoned. In Jabal 'Amil's history, the deaths of the illustrious ulama Muhammad Bin Makki (d. 1384), known as the First Martyr (*al-Shahid al-Annal*), and Zayn al-Din bin Ahmad (d. 1558), the second martyr (*al-shahid al-Thani*), only encourage such historical perspective.²²

As the birthplace of Kamil Bey Al-Assaad Sr., Taibeh was also the village from which the clan ruled all of Jabal 'Amil. The palace built in his honor, *Qasr Al-Assaad*, was the family's seat of power and came to symbolize their political authority over the entirety of the South. In his obituary for Kamil Bey Al-Assaad Sr., Amir Shakib Arslan writes:

¹⁷ Tamara Chalabi, *The Shi'is of Jabal 'Amil and the New Lebanon: Community and Nation State, 1918-1943*, 1st ed (New York: Palgrave Macmillan, 2006). 23

¹⁸ Ibid., 28

¹⁹ Ibid., 28

²⁰ Ibid., 28

²¹ Ibid., 23

²² Ibid., 28

“The latest news mourns *al-Badr al-Kamil*, the full moon, and *Amal al-Amili*, the Hope of the Hopeful, the *z’a’im* of Jabal ‘Amil. [...] His place in Taibeh, in Jabal Hunin was a base for delegations from everywhere. He built a large house on a high peak where we used to see it full of men and warriors of all creeds, Sunnis, Shi’is, Arabs, Christians, and foreigners.”²³

Kamil Bey Al-Assaad Sr.’s authority would be inherited by the two subsequent generations of Al-Assaads until the disbanding of the feudal system, the fall of the Ottoman Empire, the imposition of the French Mandate, and the establishment of the New Lebanon dissolved any such claims. In the absence of major political authority, *Qasar Al-Assaad* ultimately became associated solely with Umm Kamil and the village legends that connect the two. What follows is not sourced from any written or historical accounts but is based instead on a series of conversations with a native villager. The value of the conversations is not necessarily premised on their accuracy, but on their ability to speak to the survival of a significant oral tradition that continues to shape the character of Umm Kamil in the eyes of the village public.

Perhaps best known about Umm Kamil was her daunting demeanor, a testament to her family history and distinguished lineage. Few, if anyone, ever dared to challenge her in conversation, and many were known to bow out of the way when they encountered her in the street. The respect the villagers exercised towards Umm Kamil triggered an immense sense of intimidation that instilled a very real fear into those who chose to duck into shops and side streets rather than face her in the marketplace. It was better to have sought refuge behind the street vendor’s cart, than to risk somehow wronging Umm Kamil and her family with your presence.

Those closest to the palace on the hill are said to have sent word out as soon as they heard the great front doors creak open to allow Umm Kamil out for the afternoon. News of her movements would spread quickly from the hill, down to the village marketplace, and into the stores where shopkeepers would immediately shift their wares to her liking. A theatrical storm of activity across the entirety of the *saba*, or square, villagers would hurriedly straighten their clothing, dust their windowsills, and usher their children out of the street in anticipation of Umm Kamil’s descent from the palace. These hyperbolic recollections precisely embody how Umm Kamil existed in the imagination of the village commoner, of the ways in which she came to command the attention and esteem of those around her.

²³ Muhsin al-Amin, “A’yan al-Shi’a fi Jabal ‘Amil bayn al-Mabda’iyya wal-hifaz ala al-dat,” in *al-Muntalaq* (Beirut: Matba’at al-Insaf, 1957-1962). 66

These interactions are said to have only intensified following the passing of her husband in 1960 and her son's subsequent relocation to Beirut due to parliamentary obligations. No longer eclipsed by her husband or son, Umm Kamil assumed her position as the eldest and most powerful member of the Al-Assaad clan living in Taibeh. Her newfound power was no small threat to the many men of the village accustomed to their own patriarchal authority and was even met with anger by women who protested her deviation from the norm as housewife and harvester. And although these criticisms were, of course, never directly articulated to Umm Kamil, she always managed to pick out the sowers of discontent. Villagers worried about being implicated in such conversations would often choose to report directly to Umm Kamil and gain her confidence instead. In other words, the trust they had in each other was dissolved in favor of gaining hers. The fear of Umm Kamil that prompted these confessions ultimately won her complete access to the conversations of all those who secretly wished to challenge her authority. So pervasive was her reputation as Taibeh's all-hearing matriarch, that villagers found themselves speaking at a whisper whenever they passed the palace.

Although this behavior has its roots in the respect villagers once held for the Al-Assaad family, this legacy posed very little authority over the newer generation of Taibeh villagers who did not know of or care much for their ancestors' formalities. In fact, they found their parents' reverence for the Al-Assaads laughably irrational. And yet, some of the oldest villagers still held to the following saying:

“to be a *fellah*, or peasant, is to be a *fellah* in one's nature and entire place in the world; it is the name of the person's essence, not of an occupation, and that essence is defined by exclusion from the honorific universe of the beys and the aghas.”²⁴

But it is this very sense of exclusion that was challenged by youth who instead used their imagination to transgress rather than to surveil. In challenging the relationship between peasant and ruler, the youth of Taibeh instead crafted a version of Umm Kamil that saw her not as an omniscient matriarch, but as a sour old lady simply intent on scaring their parents. She soon came to be mentioned most often in passing taunts and jabs. “Don't say that or Umm Kamil will hear!” was meant to poke fun at the snarkest gossips while “Did you catch that Umm Kamil?” reprimanded the nosiest eaves droppers of the bunch.

²⁴ Chalabi, *The Shi'is of Jabal 'Amil and the New Lebanon*. 19

And so the significance of Umm Kamil's character does not exist so much in the fear her presence once inspired, but in how it changed over time in ways that continue to assert her place in Taibeh's oral tradition. The transformation of Umm Kamil in the village's collective imagination – from a figure capable of imposing tangible consequences to the character of a rural myth – is perhaps the most crucial aspect of her legacy. Umm Kamil eventually came to lurk in the village shadows, under every bed, and behind every curtain. She listened in on the most suggestive conversations, on the most clandestine of meetings and the most questionable of affairs. If elsewhere across the country parents drew on tales of Jinn and the supernatural to reprimand the misbehavior of their children, the adults of Taibeh warned against the arrival of Umm Kamil as mediator between this world and that of the spirits. If they continued to cause trouble, she would be the one to report them to the wolves and Abou Kis, the villainous nocturnal kidnapper. It is precisely this integration of Umm Kamil into so many of the village's tall tales that continued to ensure the survival of her character.

In fact, it was towards the end of her life that one might argue her character was doubled, although one had very little to do with the other. While one version of Umm Kamil lived out her last few days in *Qasr Al-Assaad*, another manifested a presence in every house, in the imagination of every village man, woman, and child. More interesting still, however, is the politicization of Umm Kamil the rural character following the death of herself, the political figure, a transposition that can only be understood through the escalation of tensions at Lebanon's southern border in the late 20th century.

While the complexity of the Lebanese-Israeli conflict exists almost entirely out of the scope of this thesis, of relevance here is Israel's incessant surveillance of the villages of Jabal 'Amil prior to their occupation of South Lebanon and the establishment of the South Lebanon Security Belt from 1985 to 2000. This surveillance relied heavily on reconnaissance missions that sent military aircraft to patrol the airspace above Jabal 'Amil each night. Taibeh, located only a few kilometers away from the Southern border, was regularly frequented by such planes, the most infamous of which was the M.K. An uninvited nocturnal visitor, the surveillance of the M.K was quickly grafted into the character of Umm Kamil as the village's prying ear. This has much to do with the unfortunate similarities between the two names. An emphasis on the *Mim* and the *Kaf* (M.K) immediately evoke the name of the matriarch herself – Umm Kamil / Mm Kamil / M Kamil / MK. This association lingers even today, nearly 50 years since the military surveillance began. Continued violation of airspace on a near nightly basis still has villagers in Taibeh turning to each other to say things like: "Umm Kamil is here, bring

the kids inside and shut the window.” And it is precisely the militarization of her character that has emptied it of any of its earlier innocence or humor. Now Umm Kamil only brings fear and discomfort, a very different kind of intimidation other to the theatrics she once inspired by simply stepping out her front door so many decades ago.

And so, if the memory of Umm Kamil continues to linger across the village, slowly surrendering to the narratives of violence and extraction that have come to define it, how can the Path of Nightrise, the central concern of this work, anchor the fragility of this memory within an artifact? And how might this artifact reposition listening not as an act of violent surveillance, but as an instance of imagination, one that might “lubricate the machinery of collective mythmaking”²⁵? How can the path draw on the characteristics of the night to once again ground Umm Kamil in Taibeh, in the collective imaginary of its people, rather than in the physical presence exerted by external forces?

Few have managed to capture the relationships that abound between hearing, darkness, and imagination as well as Jorge Louis Borges, and it is to him and the story of the Aleph that we turn to answer these questions. The short story originally published in 1945 follows a fictional Borges as he narrates his encounters with Carlos Argentino Daneri, a self-obsessed and unremarkable poet. When a café on Daneri’s street attempts to tear down his house for its expansion, he is furious because that would entail the destruction of the Aleph in his cellar. Daneri insists that he cannot possibly write his poetry without the guidance of the Aleph, a mysterious force ultimately revealed to be a point of reference in space that contains all other points that have existed, that exist now, or that will exist. Initially, the narrator himself does not believe in the existence of such a point until he encounters it himself in Daneri’s cellar and details the following:

On the back part of the step, toward the right, I saw a small iridescent sphere of almost unbearable brilliance. At first, I thought it was revolving; then I realized that this movement was an illusion created by the dizzying world it bounded. The Aleph's diameter was probably little more than an inch, but all space was there, actual and undiminished. Each thing (a mirror's face, let us say) was infinite things, since I distinctly saw it from every angle of the universe. I saw the teeming sea; I saw daybreak and nightfall; I saw the multitudes of America; I saw a silvery cobweb in the center of

²⁵ Momtaza Mehri, *I See That I See What You Don't See*. 333

a black pyramid; I saw a splintered labyrinth (it was London); I saw, close up, unending eyes watching themselves in me as in a mirror; I saw all the mirrors on earth and none of them reflected me; I saw in a backyard of Soler Street the same tiles that thirty years before I'd seen in the entrance of a house in Fray Bentos; I saw bunches of grapes, snow, tobacco, lodes of metal, steam; I saw convex equatorial deserts and each one of their grains of sand.²⁶

Although the narrator found himself intensely captivated by the Aleph, he hides his emotion from his rival out of spite, thus causing Daneri to question his own sanity. Upon leaving Daneri's home, the narrator is paralyzed by the fear of familiarity in everything and everyone, a Deja-vu initially visualized in Daneri's Aleph, and is afraid by the possibility of no longer being surprised by anything anymore. But in a postscript dated March 1, 1943, the narrator concludes the Aleph in Daneri's cellar to be a fake, and that a real one is hidden within the stone pillar of the Amr Mosque in Cairo. Unlike all other fake Alephs, the Aleph hidden inside the column is not an optical instrument. "No one, of course, can see it, but those who put their ear to the surface claim to hear, within a short time, the bustling rumor of it [...]"²⁷

For readers, it becomes clear then the relationship between Daneri's mediocrity as a poet and the optical Aleph which, for all its wonders and sights, only atrophies the mind²⁸. Daneri's Aleph, rather than trigger his imagination, restrains it in its limitless access to the optical realm. It ensures that he is a mere recipient of information and explains the exaggerated view he has of his own capacity as a writer. This self-obsession is reminiscent of key points made in *Ways of Seeing*, where John Berger argues that the convention of perspective developed during the Renaissance contributed to the growth of individualism in the West by centering everything on the eye of the observer²⁹. This is especially other to the Aleph hidden within the stone pillar, which relies on hearing and the imagination to uncover its secrets. As Max Ubelaker Andrade puts it, "the story reminds us that to read is to conjure a 'visual' world using the power of our own minds and not, crucially, waiting passively to be provided with entertaining stimuli."³⁰

²⁶ Jorge Luis Borges and Andrew Hurley, *Collected Fictions*, Penguin Classics Deluxe Edition (New York, NY: Penguin Books, 1998). 283

²⁷ Ibid., 285

²⁸ Ubelaker Andrade, *Borges: beyond the Visible*. 59

²⁹ David Howes and Constance Classen, *Ways of Sensing: Understanding the Senses in Society* (New York: Routledge, 2014). 1

³⁰ Ubelaker Andrade, *Borges: beyond the Visible*. 15

This tension between Daneri's fake optical Aleph and the one within the stone pillar meant to activate the mind echoes the tension between the militarized Umm Kamil, which only generates the same singular image of an approaching M.K aircraft, and the older Umm Kamil as a rural tale, whose character once produced countless imaginary encounters through the advent of listening. In other words, Umm Kamil herself embodies the transformation from a real Aleph to a false one, from one that is essentially aural (she will hear you!), to one that is merely optical (the aircraft surveilling the skies).

And so I question how the stone pillar and its aural Aleph might be negotiated across nightrise to inspire a station capable of reversing this very transformation. How might the Aleph of this station whisper secrets relevant to the inhabitants of Taibeh, secrets that trigger new tales and narratives? The key, of course, seems to lie in the characteristics of the stone pillar itself – the structure embodying the Aleph within. It is this idea of the unseen, of the darkness within the inner column, that allows the Aleph to transfer its meaning into the minds of its listeners when they place their ears at its surface. This suggests that a dismantling of the seemingly unyielding image of the aircraft will first and foremost rely on forging a new relationship between the unseen and the aural, a relationship that relies on the imagination to counter the narratives of violence that have come to overtake the sense of sound. And it is precisely this relationship that might produce a new ear on the path for Umm Kamil.

Like the pillar, the station proposed here only speaks through the unseen, and the clarity of its meaning is only elucidated with the rise of night. Umm Kamil, as an aural conduit of nightrise, mediates dialogue between the various components of the station and the landscape around it. She guides conversation between a sphere of concrete meant to focus sound waves into specific points as they bounce around its curved shell, and its vibrating metal receptor designed to capture the point of convergence of each such wave. Together, these components allow one to map out the respective angles of said waves and identify the direction of the sound in question. This station is not unlike the English 'sound mirrors' of WWI. Designed to give advance notice of approaching aircrafts by concentrating the sound of their motors in the distance in a way that might be mapped by the attending officers, these massive shells of sculpted concrete still dot the English countryside to this day. Because the sound mirrors were designed specifically to detect sounds coming in from the sky, the waves were always meant to converge at a focal point in the shell's lower half.

This first station is thus, in many ways, immensely ironic. It employs military-grade technology in the village of Taibeh in its effort to demilitarize a rural legend. And while observing the station itself only further reinforces the violence of surveillance triggered by an approaching M.K, the Borgesian echoes here are clear. Surrendering to the image of the station only further reinforces our own limited characterization of Umm Kamil. The visual associations here are purely militaristic while the aural dimensions activate the exact opposite. It is specifically the tension between the object's physicality and the nature of its whispers that is at work here. In other words, it is, essentially, an artifact designed to implore its listeners to mistrust the optical.

And unlike the sound mirrors of WWI, this station and its retractable metal receptors are designed to only channel sound waves mirrored in the upper half of the sphere— those specifically reaching the structure from the valley. Umm Kamil thus receives sound waves from all directions but ultimately turns a deaf ear to the sky. While she formally acknowledges the vibrations passing above the village, she chooses to instead entertain alternative forms of auditory imagination. And this is where the station goes a step beyond the Aleph at the Amr Mosque: while its stone pillar draws on an inner darkness to transmit its whispers, on the unseen and lack of visual stimuli, Umm Kamil here relies also on the outer darkness. Where she whispers softly during the day, she is made to sing boldly throughout the night.

This sensitivity is designed by orienting the station north in favor of the nightly shift in wind direction [Drawing 3.2]. Only come nightrise are the valley's many different sounds thus amplified by Umm Kamil. The specificity of this alignment allows her to magnify the distant flow of the river, the rustling of leaves, the mosque's call to prayer and the buzz of insects who, together, embody the aural spectacle that is nightrise across Taibeh. Designed to capture both sporadic and recurring resonance, there are certain sounds that will always reach Umm Kamil at the same position and angle. In fact, carved onto the station's metal receptor are the coordinates of all such regularities. Together, they create an auditory record of the village that might be revealed only at night by those adjusting the receptor's telescopic arms³¹. Should one want to focus and amplify, for example, the evening call to prayer, they need only locate the corresponding carving on the metal beam and adjust the receptor accordingly.

³¹ We must question here what it means for the all-hearing ear, for the keeper of the village's oral legacy, to be female when the all-seeing eye, the gendered panopticon, is male. How does this relate to what Donna Haraway calls the 'conquering gaze from nowhere,' a gaze that is always unmarked, and therefore already markedly white and male, and one that claims a power to 'represent while escaping representation?'

Each part of the station comes together in a version of Umm Kamil meant to pay tribute to a different kind of darkness, one that clarifies rather than obscures, one that pulls apart a tainted memory in an attempt to rewrite it. And it is the speed of this regenerative erasure that is reflected formally by the steps of the station, each of which exists as an imprint of the mountain's shadow. It is the shadow's expansiveness, its movement at more than a meter per minute, that create the landings of the staircase leading up, towards Umm Kamil [Drawing 3.1].

In this way, Umm Kamil then relinquishes her associations with war and surveillance and assumes a new personality, one that is deeply rooted in the aural life of the village. She recognizes that the nocturnal experience is primarily auditory, and that the droning of aircraft is but one sound in a valley of full of those only she can capture and magnify. These sounds, unlike images, are not directional. Juhani Pallasmaa reminds us that "Sight isolates, whereas sound incorporates; vision is directional, whereas sound is omni-directional. The sense of sight implies exteriority, but sound creates interiority. I regard an object, but sound approaches me; the eye reaches, but the ear receives."³²

And that, perhaps, is the magic here, that the little concrete sphere that is Umm Kamil might capture the valley's aural life and offer it to those who surrender to the unseen. One will likely not always recognize exactly what they are hearing, what series of interactions have combined to create the sound they are now receiving. The imagination this type of listening provokes frees Umm Kamil once more to pry apart each crackle, creak, and snap made to echo across the landscape. She resumes her position under every rock, behind every tree, within the river, and across the souk – a timeless testament to the aural spectacle of Taibeh at nightrise.

³² Juhani Pallasmaa, *The Eyes of the Skin: Architecture and the Senses*, 3. ed (Chichester: Wiley, 2012). 53

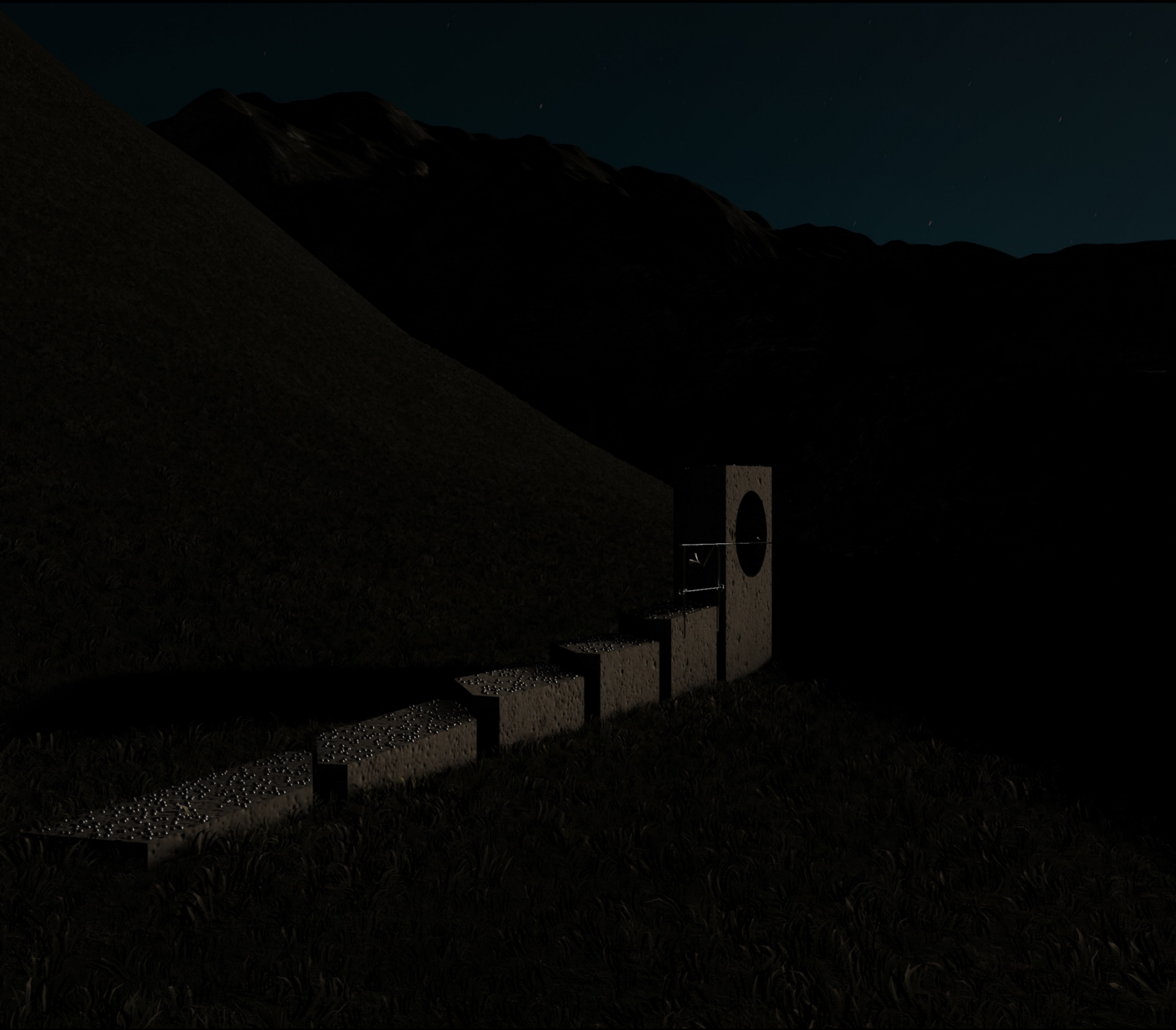

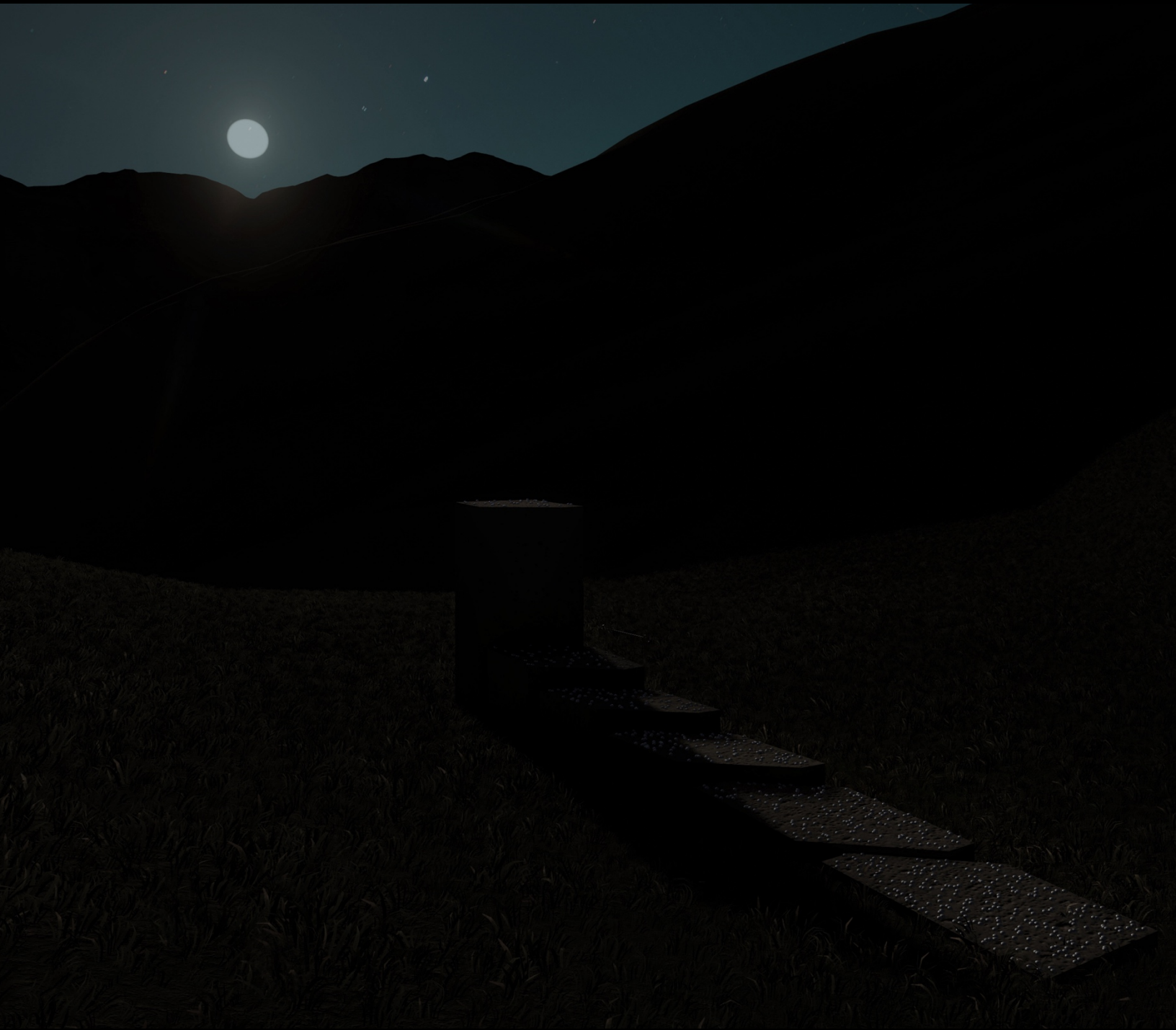

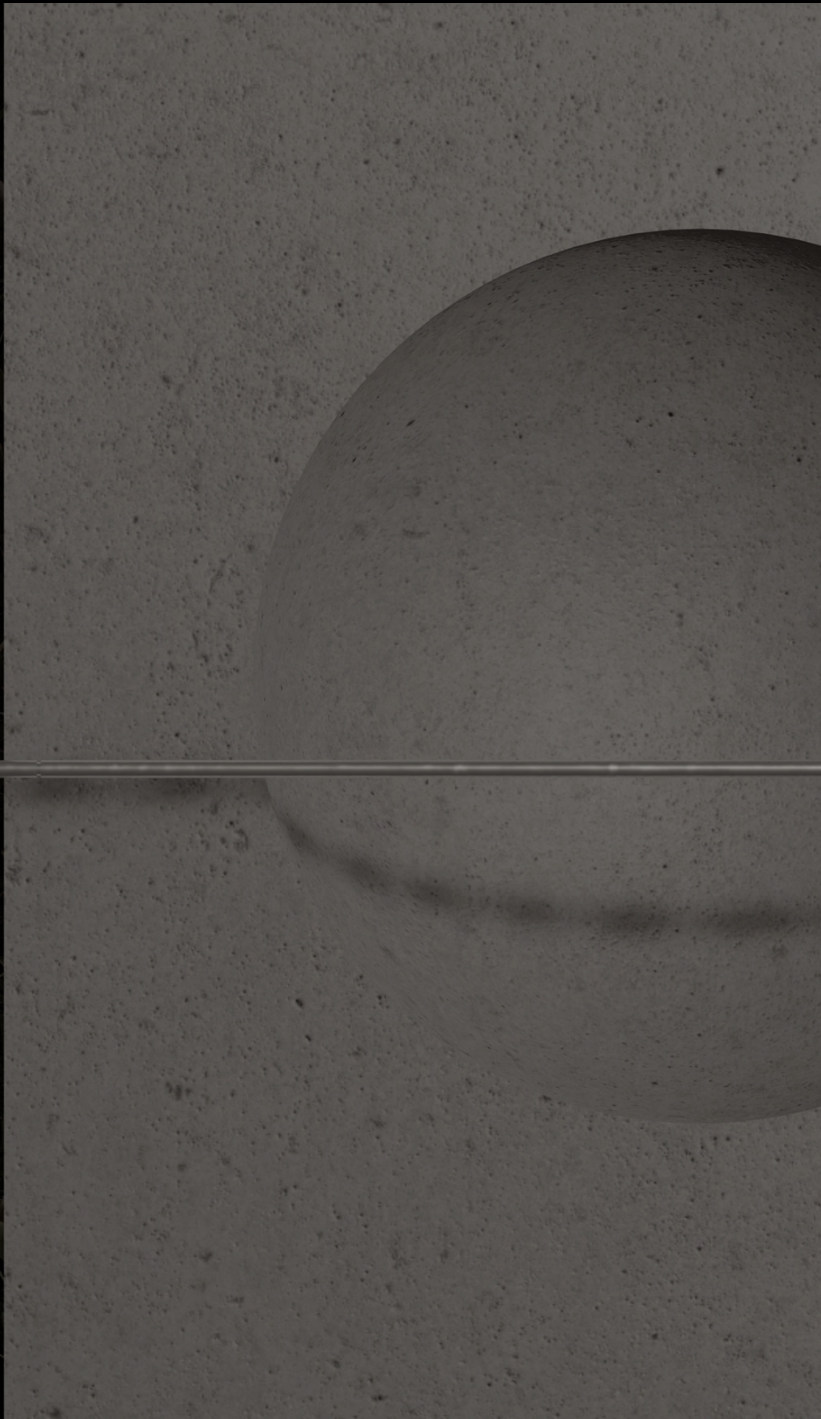
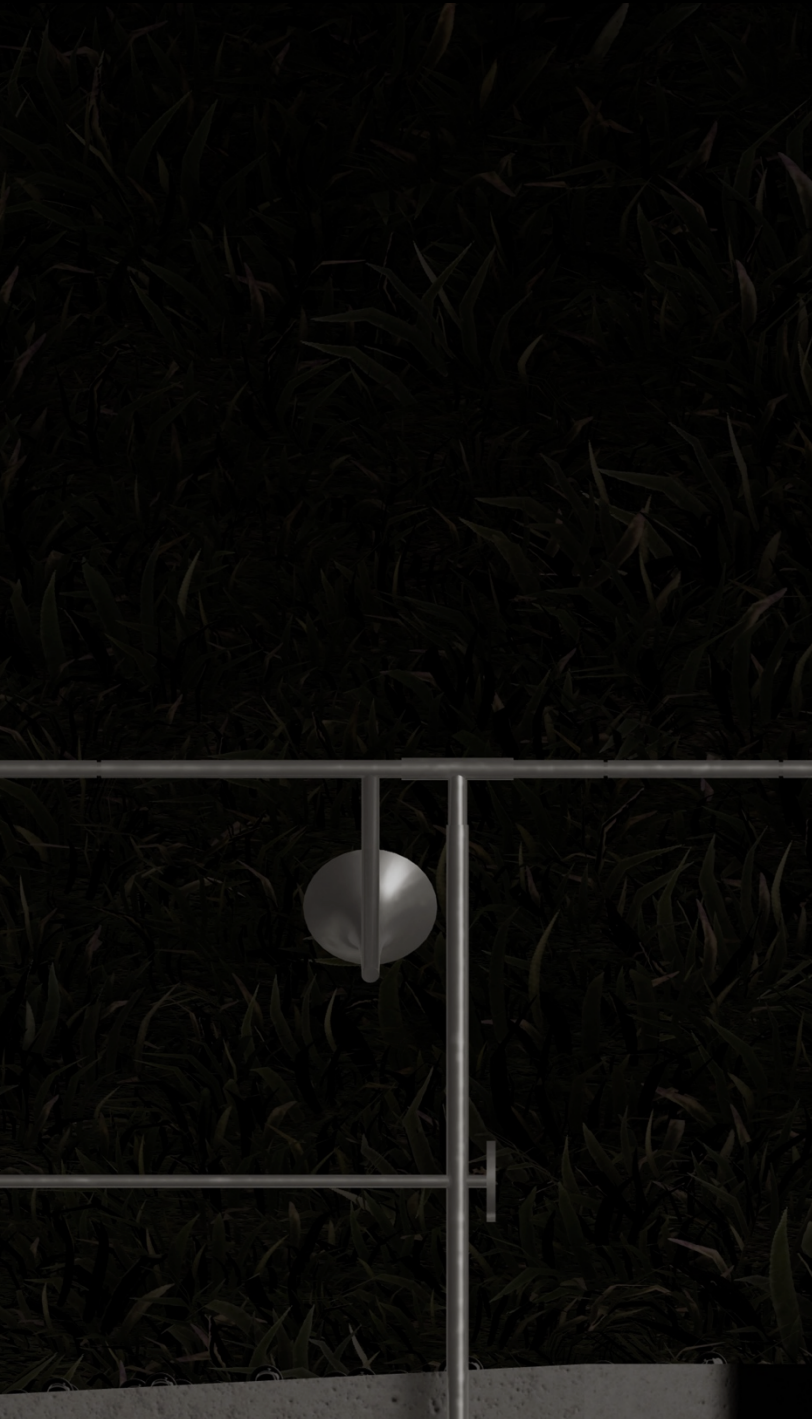

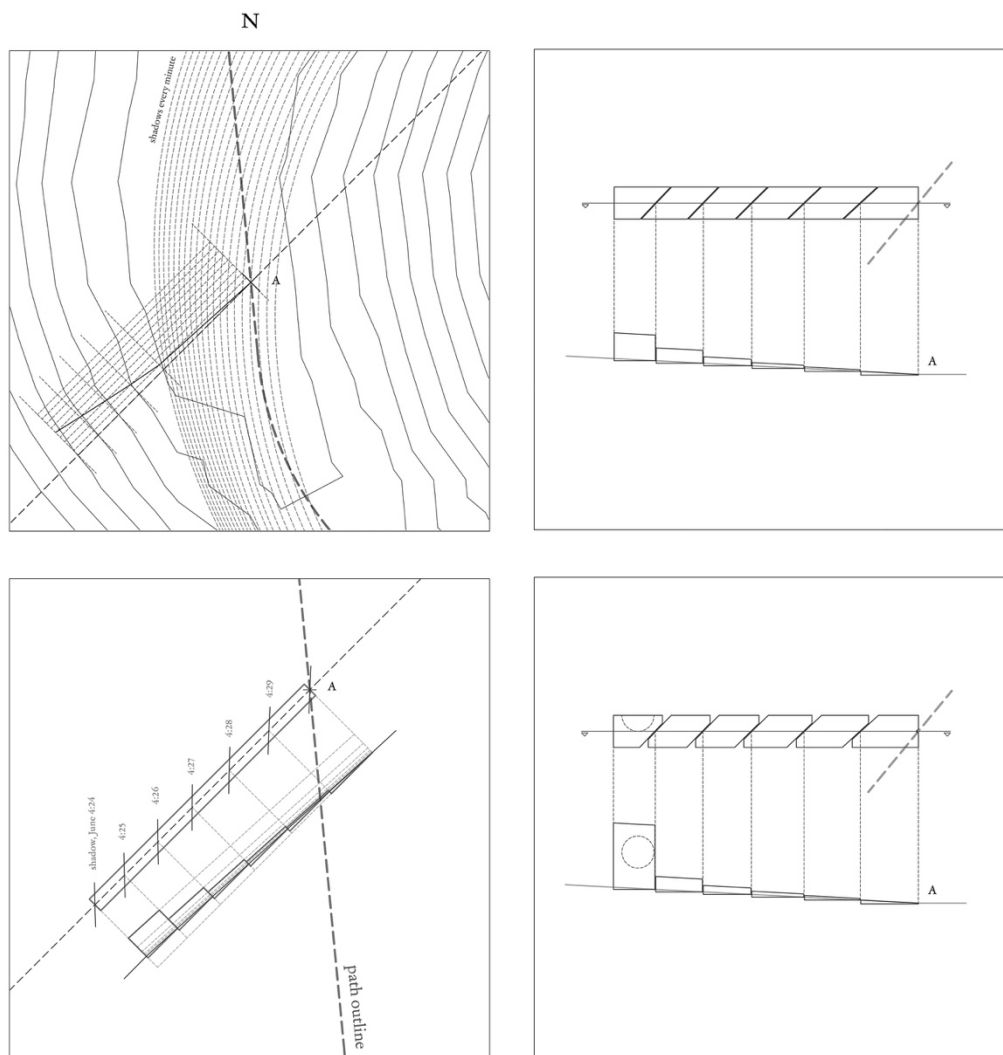

Drawing 3.1 Umm Kamil's steps trace the valley's shadows at one-minute intervals.

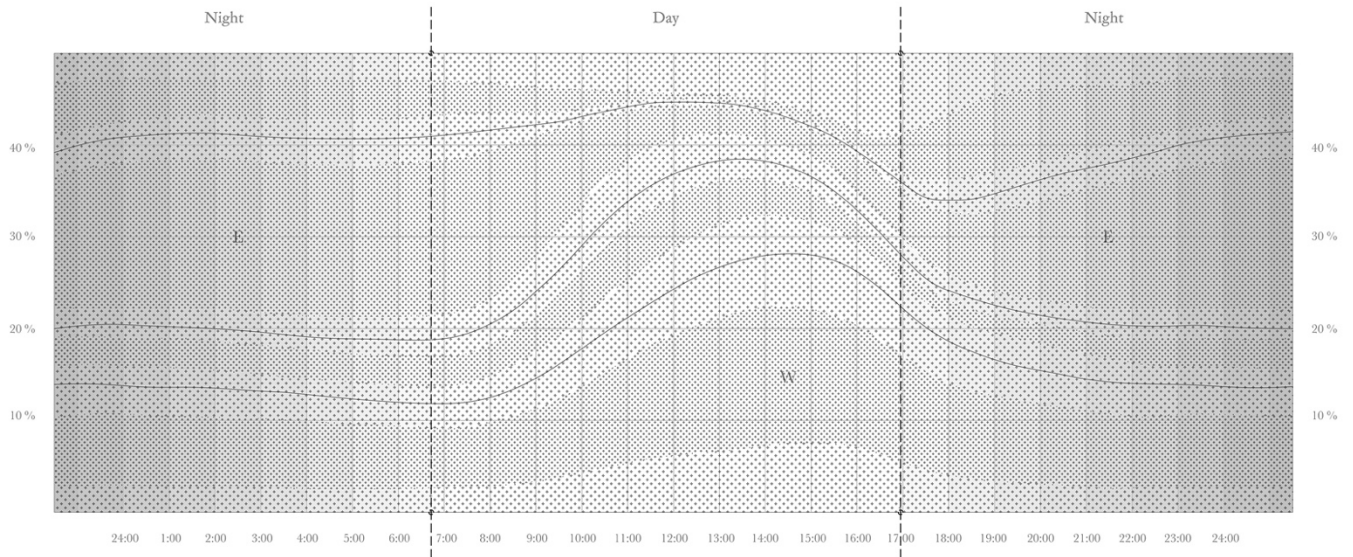
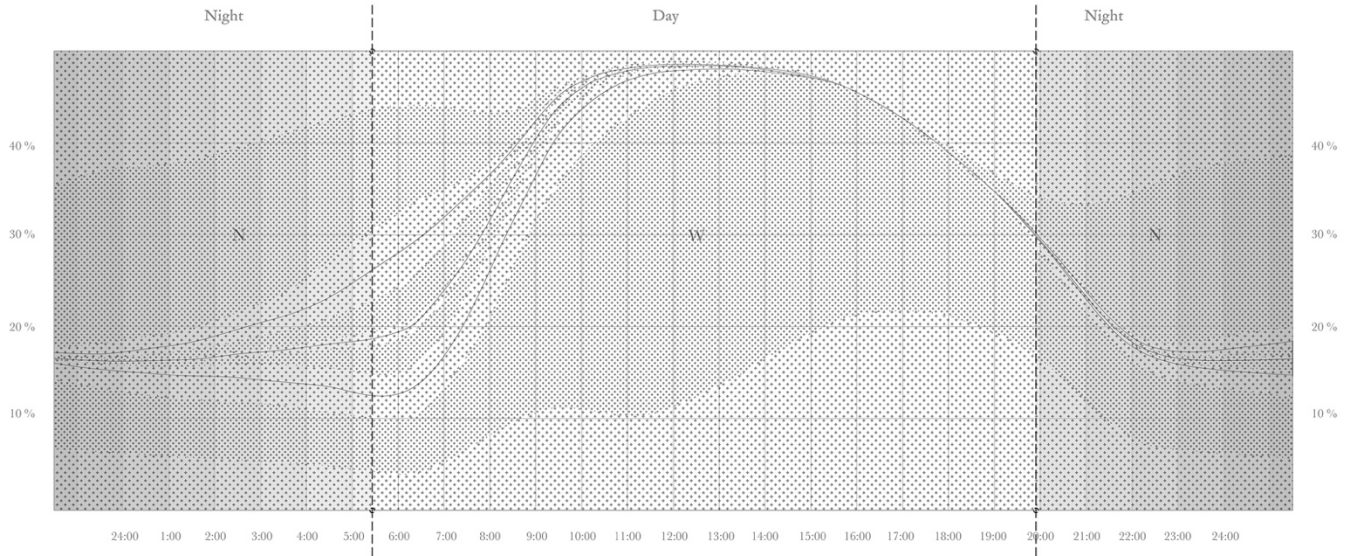

Drawing 3.2 Every night, the direction of the prevailing winds shifts to either north or east.

c. A LESSON IN ASTRONOMY

In the same ways that the Path of Nightrise draws on the transformations of the valley to relocate the myth of Umm Kamil from the sky to the village, it too moves her presence from the ruins of a hilltop palace to the darkness of a valley below where both silence and sound activate a collective imagination ultimately designed to free her. But that is not to say that the valley can or should be made to absorb all such stories. Although presently unscathed by human activity, the valley is far from empty or dormant. Rather, relocating Umm Kamil specifically relies on the inadequacy of her former hosts (the sky and palace) as much as it does the valley which, as is evidenced by stories of the Taibeh elders, holds its own myth. At work here then is not the mere aggregation of myths meant to imbue the path with a certain cultural significance, but the careful integration of stories whose very survival depends on their ability to dialogue with the night.

To honor this intention, it is integral to first question how the Myth of the Valley came to be so elusive in the first place. All but irrelevant to Taibeh's youngest generation, the valley is understood by the village youth as a distant and wild landscape, one that is of little interest or entertainment. Although the terrain is easily walkable, and but a five-minute journey from the village center by foot, it continues to be a space where only shepherds and sheep wander. Fear of lingering Israeli landmines – although the valley is said to have long since been cleared of them– is perhaps the most palpable reason for this 'distance,' one that is much more emotional than it is physical and one that can only be truly understood within the context of the Israeli invasion that lasted from 1978 to 2000.

The large-scale evacuations caused by the IDF's occupation and the establishment of the South Lebanon Security Belt Administration displaced inhabitants of the belt villages, one of which was Taibeh³³. It was during the next 15 years that an entire generation of southerners, myself included, were born and raised outside of Jabal 'Amil, primarily in the suburbs of Beirut. It was only until the year 2000 that all such villagers and their children ventured back to their hometowns, some for the very first time. Among the many other consequences born of this decades-long absence, the Myth of the Valley did not manage to survive our time away. Rebuilding homes, shops, and souks and reestablishing vital village amenities superseded the recultivation of any relationship with the valley which, in the earliest days post-occupation, acted as a funnel through which landmines were channeled until they could be removed. The Myth of the Valley was thus lost for two reasons, the first being instinctive as villagers focused their efforts on reconstruction, and the second being the fear that

³³ The South Lebanon Security Belt Administration was headed by Antoine Lahad, the leader of the South Lebanon Army funded and controlled by Israel.

recalling the significance of the valley would inspire the youth to venture into, then, dangerous territory. In other words, when made to choose between their collective memory and the safety of their children, the elders of Taibeh did not hesitate. And this is perhaps the most heartbreaking conclusion of all, that their survival relied on an erasure of their identity.

But it is here, over two decades since that return, that I hope to revive this myth, the forgotten tale of Zayn al-Din al-‘Amili’s visit to the valley of Taibeh. Known as *al-Shahid al-Thani*, or the Second Martyr, Zayn al-Din is one of the most celebrated scholars not just in the legacy of Jabal ‘Amil, but in the entire history of Shi’i Islam³⁴. According to Taibeh elders, Zayn al-Din passed through Taibeh in the sixteenth century as he was journeying from the village of his birth, Jbaa, to the village of Mays. Upon arrival to Taibeh, he was offered a lesson in astronomy by local *‘ulama*, scholars residing in the village at the time. Zayn al-Din was invited to the valley for this lesson, which started at sunset and lasted late into the evening – the length of time it took the *‘ulama* of Taibeh and Zayn al-Din to traverse the valley seven times from river to mountain. Thus was Zayn al-Din gifted a lesson in astronomy dictated not by the abstract passage of time, but rooted in their nocturnal journey across the valley. It is of note that while Zayn al-Din’s astronomy lesson is remembered today solely by the Taibeh elders, the rest of his journey to the village of Mays in 1526 is well documented. The Myth of the Valley of Taibeh chooses to recognize Zayn al-Din al-‘Amili not as the masterful Shi’i jurist who would one day be executed and martyred by the Ottomans, but as an aspiring pupil, curious about the workings of the universe and what there was to be learned from the village *‘ulama*. In other words, embedded in the Myth of the Valley is a sense of pride, not in the Shahid’s eminence, but in village elders that might help quench his thirst for knowledge, in the contribution to the scholarship of a young man that might one day become one of the most notable scholars in the history of Shi’i Islam.

The relevance of this journey to the Myth of the Valley lies in the ambitious career of Zayn al-Din al-‘Amili, of which his visit to Taibeh was only the very beginning. Through significant scholarly and educational production, Zayn al-Din would soon establish himself as one of the most renowned Shi’i authorities of the sixteenth century³⁵. In the imagination of the Taibeh elders, the significance of his journey through the valley only intensified as his social and scholarly standing grew. But while this correlation is undeniable, a more resonant interpretation of the Myth of the Valley requires that we

³⁴ Zayn al-Din al-‘Amili’s violent execution echoes the principles of struggle and martyrdom essential to Shi’ism.

³⁵ Albert Hourani, “From Jabal ‘Amil to Persia,” *Bulletin of the School of Oriental and African Studies, University of London* 49, no. 1 (1986): 133–40.

recognize the state of education in Jabal ‘Amil from the sixteenth century onwards. The rise of Zayn al-Din did not, in fact, occur in a vacuum, but was grounded in a golden age of religious, cultural and literary production across Jabal ‘Amal. This not only afforded the ‘*ulama* of the mountain an unprecedented authority, but also positioned them as essential to the spread of Shi’ism in the region, most notably across the Persian Empire. It was at this time that the Safavids rose to power and crafted an identity around Shi’ism, very much in opposition to the Sunnis of the Ottoman Empire to the west and the Moghul Empire to their east³⁶. Rula Abi Saab writes:

Two decades after the establishment of the Safavid state in Persia in 1501, the Safavid monarchs sought prominent clerics who would strengthen their rule by promoting a standard urban system of Shi‘ite worship and lend them political legitimacy against their Sunnite Ottoman foes. Neither the Qezelbāš who adhered to heterodox militant Shi‘ism, nor the erudite Persian notables who had a general Sunnite training were capable of providing the Safavid state with a collective social consciousness congenial to empire building and stability. The shahs, who were widely perceived as divinely guided charismatic leaders, gradually transformed their rule from a communal Shi‘ism to a state-operated Shi‘ism. Meanwhile, several Arab theologians from Jabal ‘Āmil in southern Lebanon, along with their families, were emigrating from Ottoman Syria to Iraq, Mecca, India, and Persia. A number of historical factors motivated this emigration, namely, a surplus of jurists who could not find a professional outlet to their expertise, first due to a decrease in opportunities within the Ottoman learning system, and second, due to their limited ability to implement and formally spread their Shi‘ite legal rulings in ‘Āmeili villages and towns, and third, due to the Ottoman suppression and threat against publicly active Shi‘ite *mojtaheds*. In addition, a few ‘Amili scholars who were professing and implementing *ejtehad* (q.v. “legal inference”) came under close Ottoman scrutiny and at least one eminent scholar, Zayn-al-Din al-‘Amili, among Shi‘ites widely known as al-Shahid al-Thani “the Second Martyr” (1506-58), was put to death by the Ottomans. The Safavids, in contrast, found the ‘Āmilis’ use of *ejtehad* helpful in developing new theological positions that supported dynastic

³⁶ Ibid., 133-40

authority and projected an image of Islamic “authenticity” to their Ottoman rivals to the west.³⁷

This makes clear that the execution of Zayn al-Din al-‘Amili cannot be dissociated from the *madrasas* and *‘ulama* that spread Shi’ism east, from Jabal ‘Amil across the entirety of the Persian Empire³⁸. For the Ottomans, the threat they posed was real, and the execution of one of the mountain’s most influential scholars was ought to be a great setback. And it was. The impact of Zayn al-Din al-‘Amili’s death on the scholarly and literary production of Jabal ‘Amil, but more importantly, on the Shi’i consciousness, cannot be overstated. The subsequent military aggression that his execution made way for saw to the destruction of Jabal ‘Amil’s key infrastructure and amenities, among them schools and libraries³⁹. The intellectual decline this in turn prompted was only further exacerbated by war, famine, poverty, cruel taxes, and forced conscription⁴⁰. Targeted cultural erasure instigated by Ottoman-commissioned research also worked to debunk any and all such intellectual contributions made by the *‘ulama* of the mountain⁴¹.

Referred to as *mitavili*, a pejorative term used to suggest extreme inferiority, the Shi’is of Jabal ‘Amil living and working under Ottoman rule were never recognized as a separate class, and by extension, were deprived of their rights as citizens of the empire. This sense of Shi’i backwardness, bred and fueled for centuries by the Ottomans, did not disappear after the empire’s fall. In the wake of the French Mandate and the imagination of the New Lebanon, the Shi’is of Jabal ‘Amil found themselves both physically and culturally weakened, cautious to ascribe to a narrative of Arab nationalism or Phoenician greatness that grounded the new Lebanese national narrative⁴². It is precisely this hesitation to adhere to either of these two narratives that pushed Jabal ‘Amil outside the imagination of the New

³⁷ Rula Abisaab, “Jabal Amel,” *Encyclopaedia Iranica*, XIV/3, pp. 305-309

³⁸ Zayn al-Din al-‘Amili was arrested in Mecca and taken to Istanbul where he was beheaded. In many ways, his execution by the Ottomans perpetuated a desire to subdue the threat posed by the *‘ulama* of Jabal ‘Amil. This desire persisted into the seventeenth and most of the eighteenth centuries but did not affect the region directly due its remoteness from the centers of power.

³⁹ Chalabi, *The Shi’is of Jabal ‘Amil and the New Lebanon*. 39. As a rural hinterland of the Ottoman empire, Jabal ‘Amil was relatively isolated prior to 1780 while it was under the leadership of Nasif bin Nassar al-Wa’ili, ancestor to the Al-Assaads. However, relentless military campaigns at the end of that century led by Ahmad al-Jazzar, the governor of Acre, ultimately came to mark the beginning of intellectual decline across the region.

⁴⁰ Taxes were imposed more severely on the people of Jabal ‘Amil because of its rich agricultural land.

⁴¹ Chalabi, *The Shi’is of Jabal ‘Amil and the New Lebanon*. 15. *Wilayat Bayrut*, a survey of the Province of Beirut that included Jabal ‘Amil, was conducted in the 1910s by two Arab Sunnis instructed to debunk intellectual contributions offered by the *‘ulama* of the mountain. Scholarly work coming out of Jabal ‘Amil was framed as “personal writing devoid of scientific distinction,” a witness to culture with no identity.

⁴² Arab nationalism across the Levant is arguably itself an image of an urban Sunni majority while Christian-backed Lebanese nationalism proposed by the French emphasized visions of a merchant republic operating along the coast.

Lebanon, and which ultimately reestablished Jabal ‘Amil as an auxiliary region called South Lebanon, one that still suffers today from much of the same narratives of inferiority and cultural irrelevance that began with the execution of Zayn al-Din al-‘Amili.

The ways in which the tale of an astronomy lesson from so long ago has picked up traces of this complex history of violence and persecution speaks to the power of an oral tradition capable of blending the real and the imaginary in favor of its community’s most foundational values and beliefs. While it is impossible to trace exactly how and when Zayn al-Din’s visit to the valley acquired the significance it has, it is specifically within the context of Ottoman persecution that the myth ultimately acquired its most political qualities. It transformed from a story that embodied pride in local scholarship to a narrative of resistance that came to extend to all of Jabal ‘Amil. And it is through this process that the Path of Nightrise seeks to capture and resituate the essence of a story that has, today, been all but lost to history.

Interested not in the immortalization of a single individual, but in paying tribute to the context that inspired Zayn al-Din al-‘Amili’s career, the station designed for this story is very much unlike the village’s latest tribute to an Iranian military leader, a statue to be installed at the mountain’s top, but a few meters away from the path and valley. If said statue is meant to symbolize today’s Iranocentric iteration of Shi’ism in Jabal ‘Amil, then this station instead recalls the intellectual and scholarly production that first spread Shi’ism east from the mountain to Persia⁴³. The contrast here is not only cultural and political, but also topographic. The mountain’s summit and statue, both ocular and diurnal artifacts, stand strictly opposed to the path and myth, both of which are understood here to be nocturnal artifacts [Drawing 4.1]. If the former work together to immortalize the existing narrative that Shi’ism in Jabal ‘Amil owes its existence to Iran, then the latter in the valley seek to do the opposite. In the words of A. Roger Ekirch, night’s paramount value lies, after all, in its negation of the waking world⁴⁴.

The challenge here, then, is to foreground the story of the valley’s lesson in astronomy while only subtly alluding to Zayn al-Din al-‘Amili. After all, the lesson and the scholar are not mutually exclusive, but their relationship here means more than the simple (and ubiquitous) eternalization of the body.

⁴³ The authority Iran currently holds over all of Jabal ‘Amil is a direct consequence of the contemporary political climate. Shi’ism across the mountain is now hardly understood beyond this direct association with Iran.

⁴⁴ Ekirch, *At Day’s Close*. 60

And so it becomes imperative to question how the path might spatialize this nuanced relationship. How might it produce an artifact that positions knowledge at its respectful center yet also alludes to the character of Zayn al-Din al-‘Amili, the Second Martyr? The station dedicated to this myth is not interested in replicating (nor can it) the same lesson the ‘*ulama* of Taibeh first offered the inquisitive scholar all those years ago. Instead, it seeks to adapt it in a way that might contribute to the education of current and future villagers, even if the lesson itself drew on the geocentric model of the universe, one that was still applied at the time of Zayn al-Din’s visit to Taibeh in the sixteenth century. A different vision of the workings of the cosmos, this model positioned the Earth at a fixed center of the universe where it was orbited by the sun, stars, and other planets. It is clearly featured in the publications of Al-Farghani who, as is detailed in the biography of Zayn al-Din al-‘Amili⁴⁵, was a major authority on astronomy in Jabal ‘Amil and the region at the time. The geocentric model is particularly interesting to this conversation on the night because, as Craig Koslofsky explains in his reflections on the work of C.S Lewis:

Our deep-seated awareness of the darkness of space was unknown to the medieval world. As C.S Lewis has observed, in the geocentric medieval view the space between the earth and the distant circle of fixed stars was illuminated: night was ‘merely the conical shadow cast by our Earth.’ Solar and divine light filled the space above the earth, and the darkness of night was local, limited to the hemisphere of the earth not illuminated as the sun rotated around it. In this geocentric view, ‘when we look up at the night sky we are looking through darkness but not at darkness.’” So Dante imagined the universe.⁴⁶

The station designed for the Myth of the Valley thus does not seek to replicate nor correct an outdated view of the galaxy but aims instead to call forth a human relationship to the night sky unspecific to any culture, era or civilization. It hopes to bind us collectively to the mysteries, wonders, and fears of a sky that implores our surrender to the vastness of the unknown. In fact, it is this very “intimacy with the night, a time for observation but also for the transmission of knowledge”⁴⁷ that echoes these experiences back through the station and across the Path of Nightrise.

⁴⁵ Alī Šādiqī and Ḥasan Muḥammad Najafī, *Al-Shahīd al-Thānī Zayn al-Dīn al-Jub‘ī al-‘Amīlī*, 2. ed, Meeting the Pious 6 (Qum: Ansariyan, 2001). 23

⁴⁶ Craig Koslofsky, *Evening’s Empire: A History of the Night in Early Modern Europe*, New Studies in European History (Cambridge; New York: Cambridge University Press, 2011). 3

⁴⁷ Marc Armengaud, Matthias Armengaud, and Alessandra Cianchetta, eds., *Nightscares: paisajes nocturnos - nocturnal landscapes*, Land & scape series (Barcelona: GG, Gili, 2009). 35

It is within this context that the station gestures toward the night sky as does a child captivated by the workings of the universe. And it is that captivation which is to be immortalized along this path. With every full moon, this station's central piece, titled at an angle equivalent to the latitude of the village, transforms into the gnomon of a moondial, and approximates the hours of the night. More than anything, the design is a testament to the value of approximation, of imprecision and slowing down, of simply appreciating the passage of time rather than relentlessly using it. A tribute to the spectacle of time witnessed through motion rather than through a passive observation of changing numbers, the station here becomes a witness to the perpetual dialogue between the earth, the sun, and the moon. Outside of the villagers' daily responsibilities, this station honors memories of the past and plans for the future, where three celestial bodies dance through space to a rhythm that stamps the valley with their timeless shadow. If the station's middle piece becomes a lunar clock with every full moon, the shrine beside it is dedicated to the workings of the stars, and is animated every single night through the motion of the Big Dipper around Polaris. It is this motion, captured by the curvature of the shrine, that allows the station to engage in yet another temporal spectacle: the telling of time on Earth, in the present, through the luminosity of faraway stars communicating a distant past. In *Darkness at Night*, Edward Harrison reminds us that:

The visible universe still extends more or less a distance fixed by the flight of light and the luminous lifetime of astronomical systems. How far light travels in the universe depends on the age of the universe, with some corrections because of expansion. [...] We look out in space and back in time. How far we look out in space depends on how far we look back in time. At the limit of the visible universe, as far back in time as we can see, lies the horizon. We look back beyond the formation of the earliest stars, beyond the formation of the giant galaxies, to the last moments of the radiation era – at the end of the big bang – when the universe was 100 thousand years old.⁴⁸

In other words, we approximate our time in the present via astral light that travels to us from the past, from hundreds of thousands of light years away. Beyond this, the station, in its capacity as a cosmic timepiece, is also designed to honor the birth of Zayn al-Din al-‘Amili on March 9, 1506 by observing the motion of the full moon that orbited Earth on that particular day [Drawing 4.2]. That specific path

⁴⁸ Edward Harrison, *Darkness at Night: A Riddle of the Universe* (Cambridge, Mass.: Harvard University Press, 1987). 185

of the moon is one that will not be repeated for another 6,939 days, or approximately 19 years. This is what is referred to as the Metonic cycle, a period of 235 synodic months after which the same phase of the moon recurs on the same day of the solar year, with respect to the same orbit. And it is precisely this cycle which inspires the composition, direction, and height of the station. Extracting the angles of this movement at every hour of the night on March 9, 1506, and projecting said calculations onto the station allows the abstract movement of the galaxies to enter in eternal dialogue with this vessel in the valley [Drawings 4.3, 4.4, 4.5, and 4.6]. Approximately every 19 years, the moon, at every hour of the night, aligns perfectly with the edges of the station [Drawing 4.7].

Detecting this activity with the human eye is this station's final trick. Defining the position of the moon at a particular hour requires two angles, azimuth and altitude⁴⁹. The station is composed of various components interspersed with gaps. Far from random, these gaps are tilted according to the aforementioned angles. Each gap follows a particular tilt, and each tilt is determined by the azimuth of the moon plotted at incremental hours of the night. In other words, these intermediary spaces act as funnels that orient the viewer toward the direction of the moon [Drawing 4.8]. Essentially then, one must align their sightline with the orientation of said tilts. This simply requires resting one's ear upon the tilted edges of these different parts and observing the sky through the gaps. While the empty space orients the viewer towards the moon's azimuth—the horizontal direction—the heights and angles of the individual parts work to carry the sightlines of the viewers to the specific altitude of the moon. And so viewers rest their ears on the station in a guided observation of the cosmos that parallels that of Umm Kamil.

Thus might one engage with a timepiece imprinted with the movements of the night sky, one that also subtly honors the memory of Zayn al-Din al-'Amili every 19 years. This in itself is a tribute to the very act of remembering, but also, perhaps more importantly, to forgetting, for one cannot happen without the other. Rather than immortalize the mere shell of a being, the station echoes the value of knowledge through motion and observation, through the freedom and clarity that darkness permits. All such values are embodied to this day by the walk of *'ulama* across the valley. One hopes that this might inspire village students and teachers alike to leave their classrooms and journey along the path at night, when the sound waves bouncing off the edges of the valley reach Umm Kamil and are

⁴⁹ The azimuth is expressed here as the angle from the north point of the horizon to the point at which a vertical circle passing through the object intersects the horizon. The altitude is determined to be the vertical angle the moon makes with the horizon.

reflected in her ear, when the movement of the moon and the stars are carried by the station to the Myth of the Valley. Might this finally resurrect a modest village's desire to quench its thirst for knowledge and imagination?

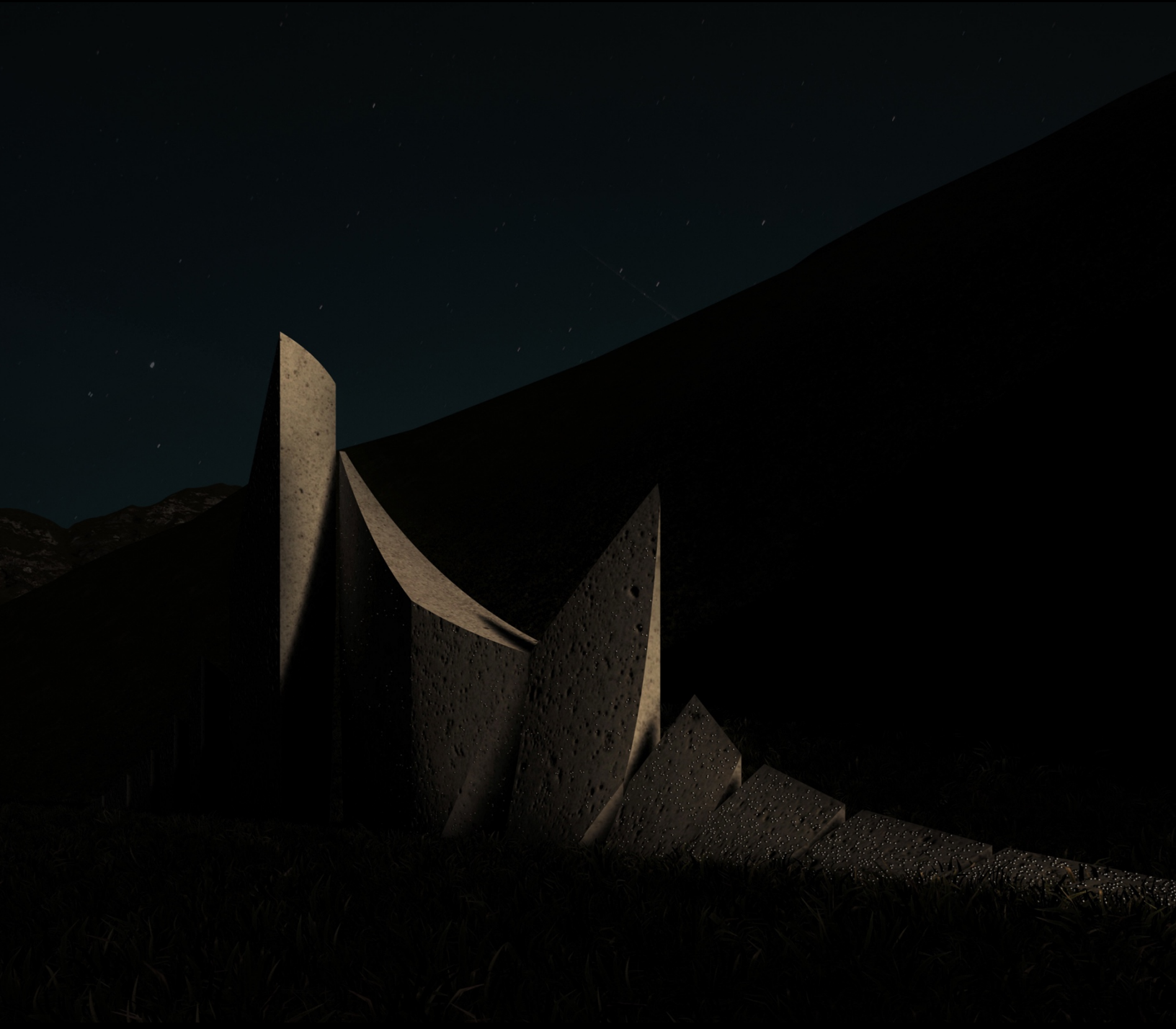

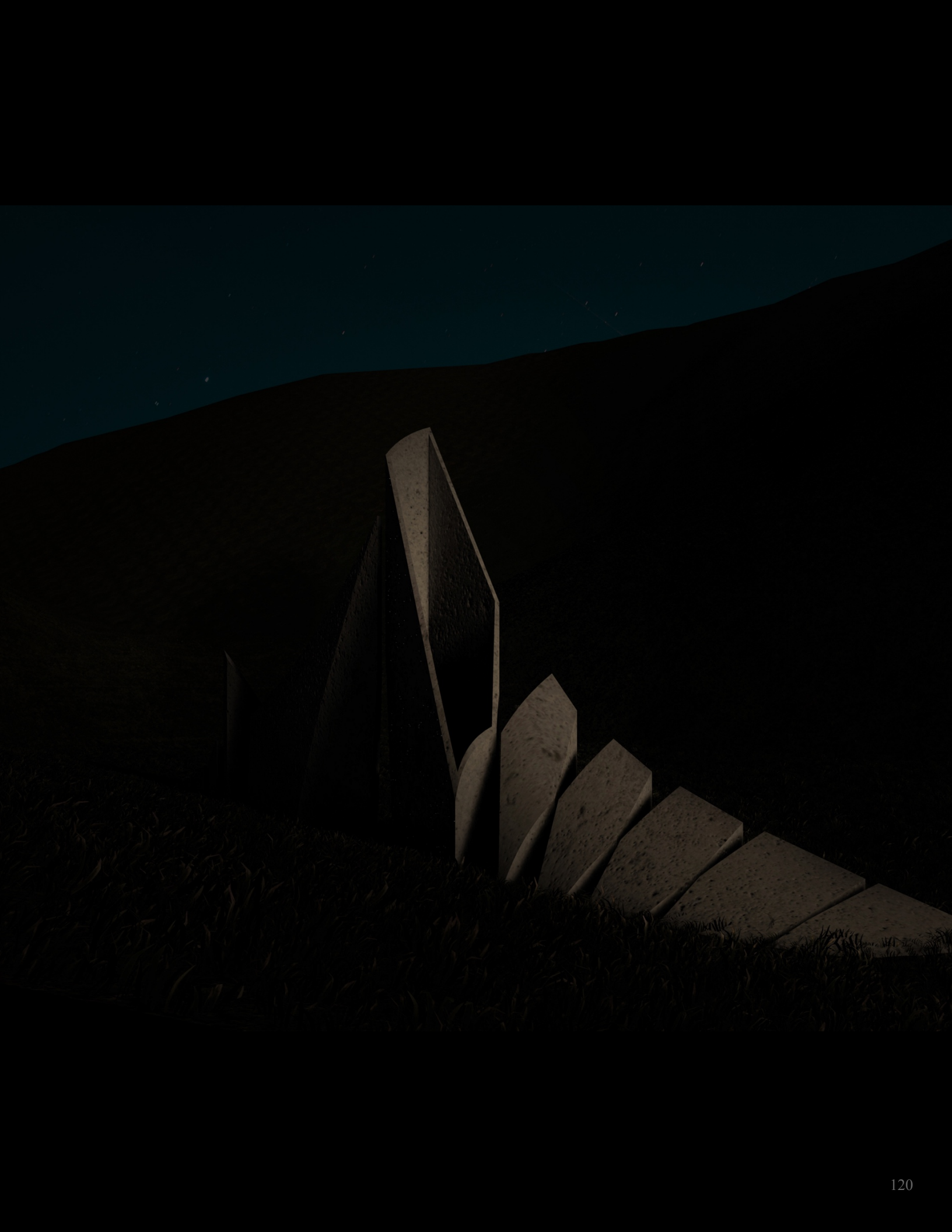

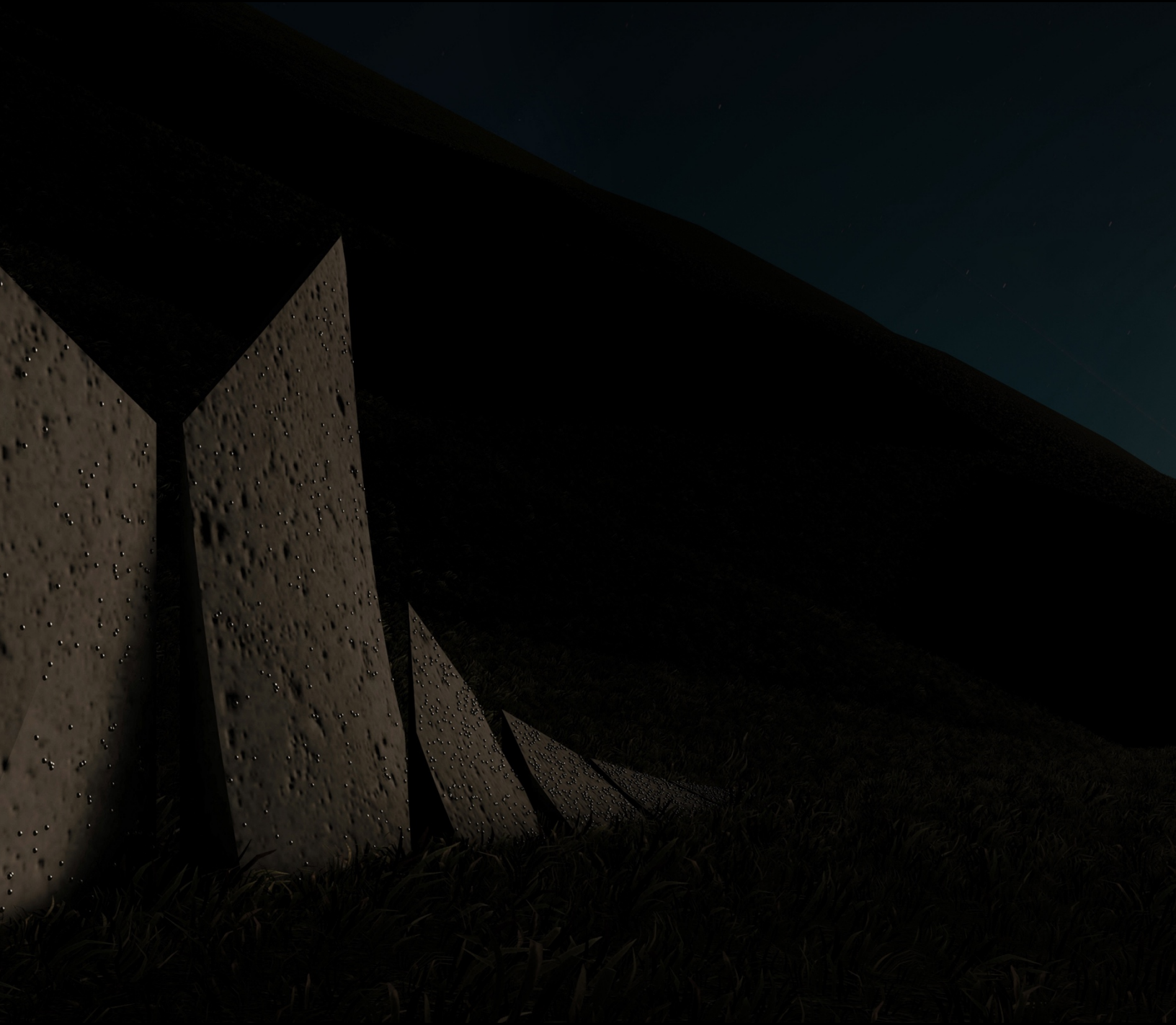

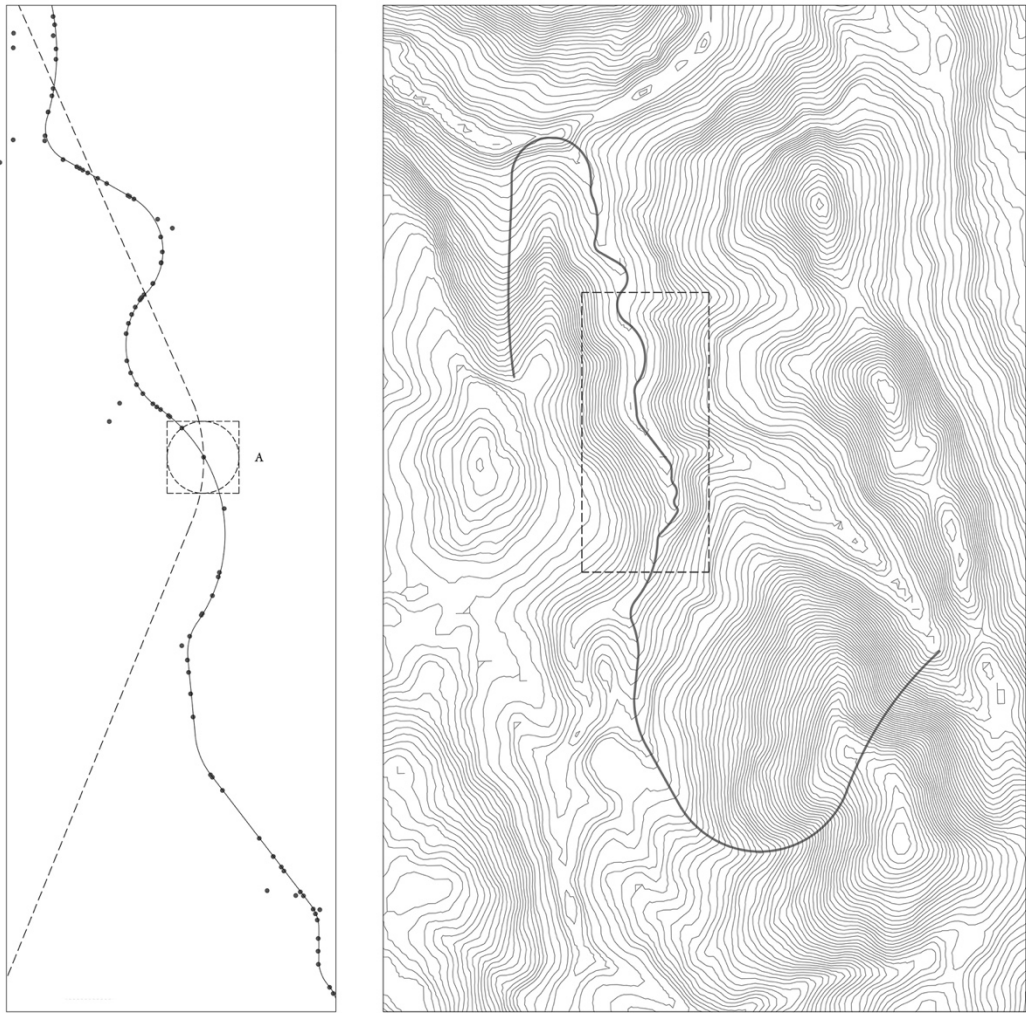

Drawing 4.1 The station in the valley as a nocturnal artifact.

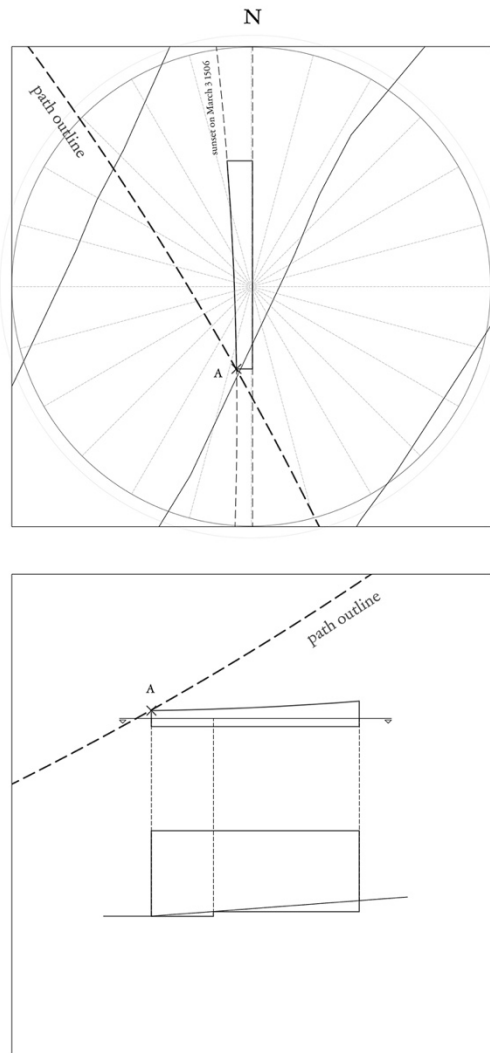

Drawing 4.1 (continued) It is the first shadow on March 9, 1506, that marks the location of the station on the path.

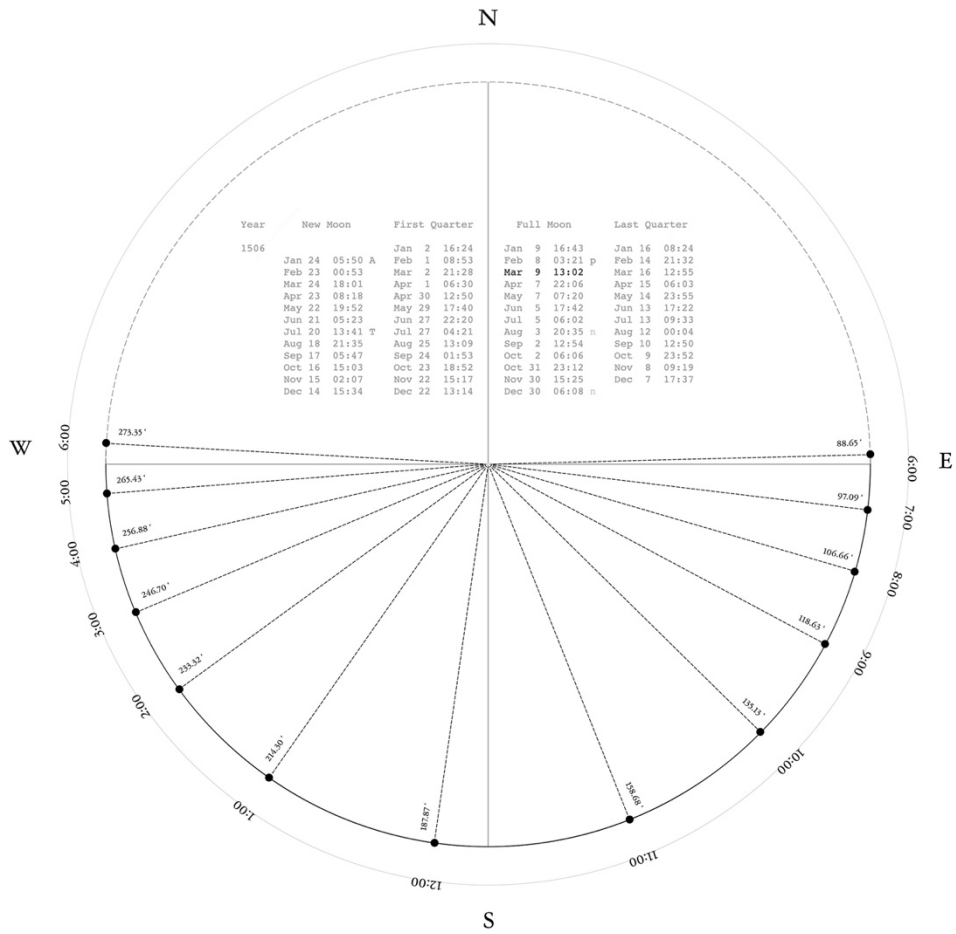

Drawing 4.2 The cycle of the full moon on March 9, 1506.

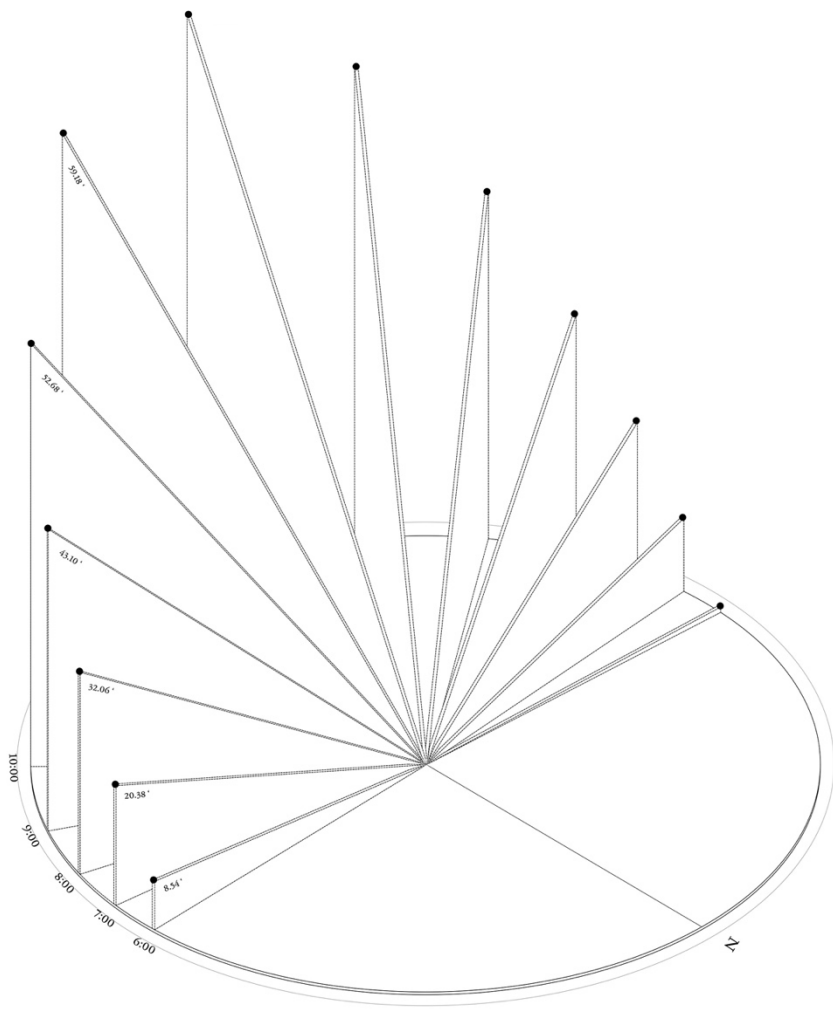

Drawing 4.3 The cycle of the full moon on March 9, 1506.

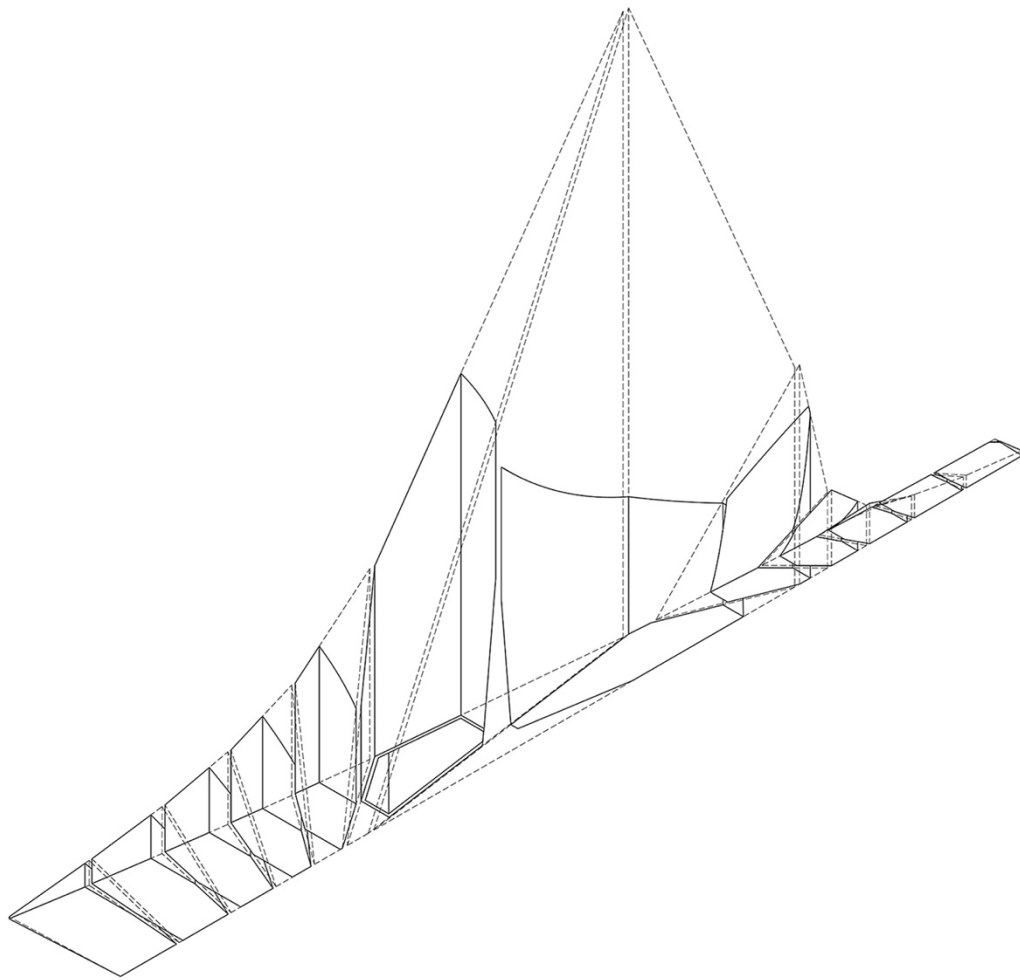

Drawing 4.4 Imprinting the cycle of the full moon onto the station.

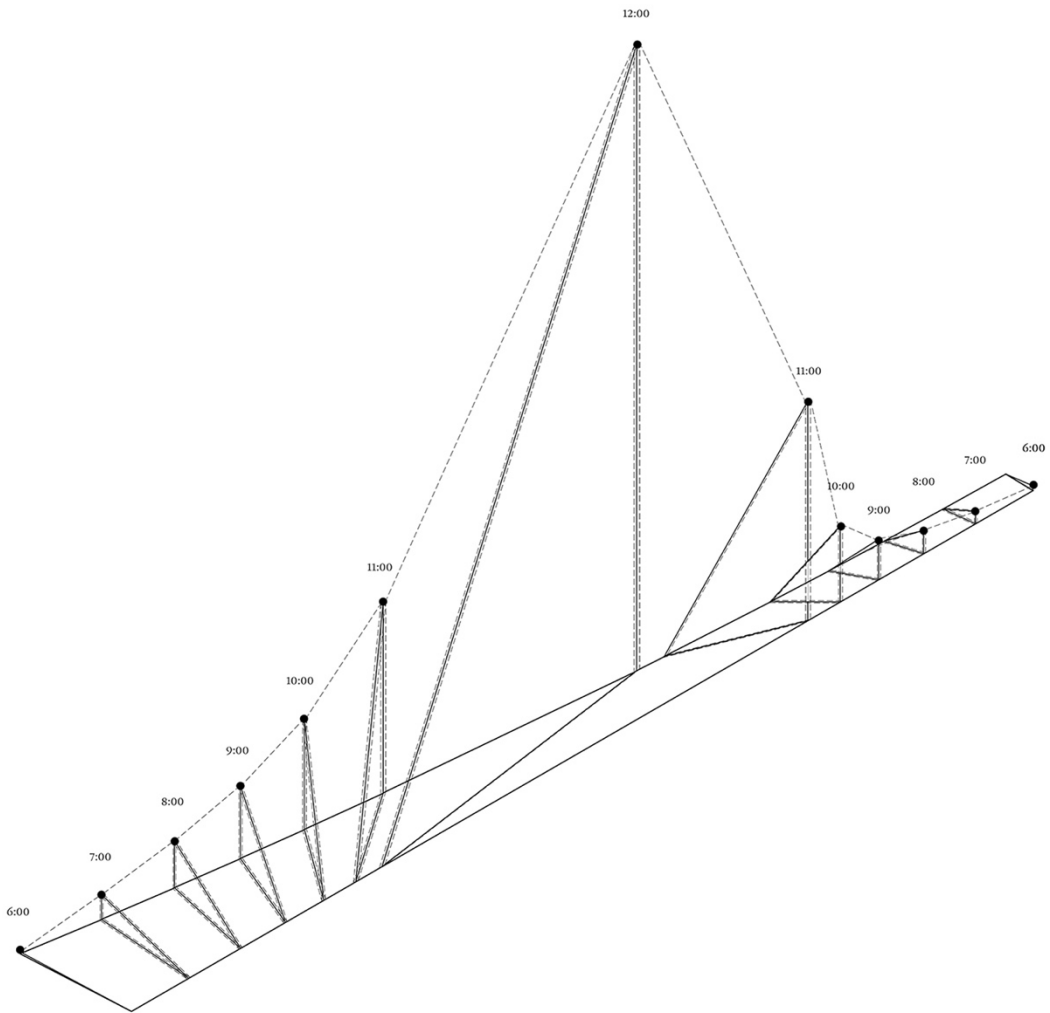

Drawing 4.5 Imprinting the cycle of the full moon onto the station (continued).

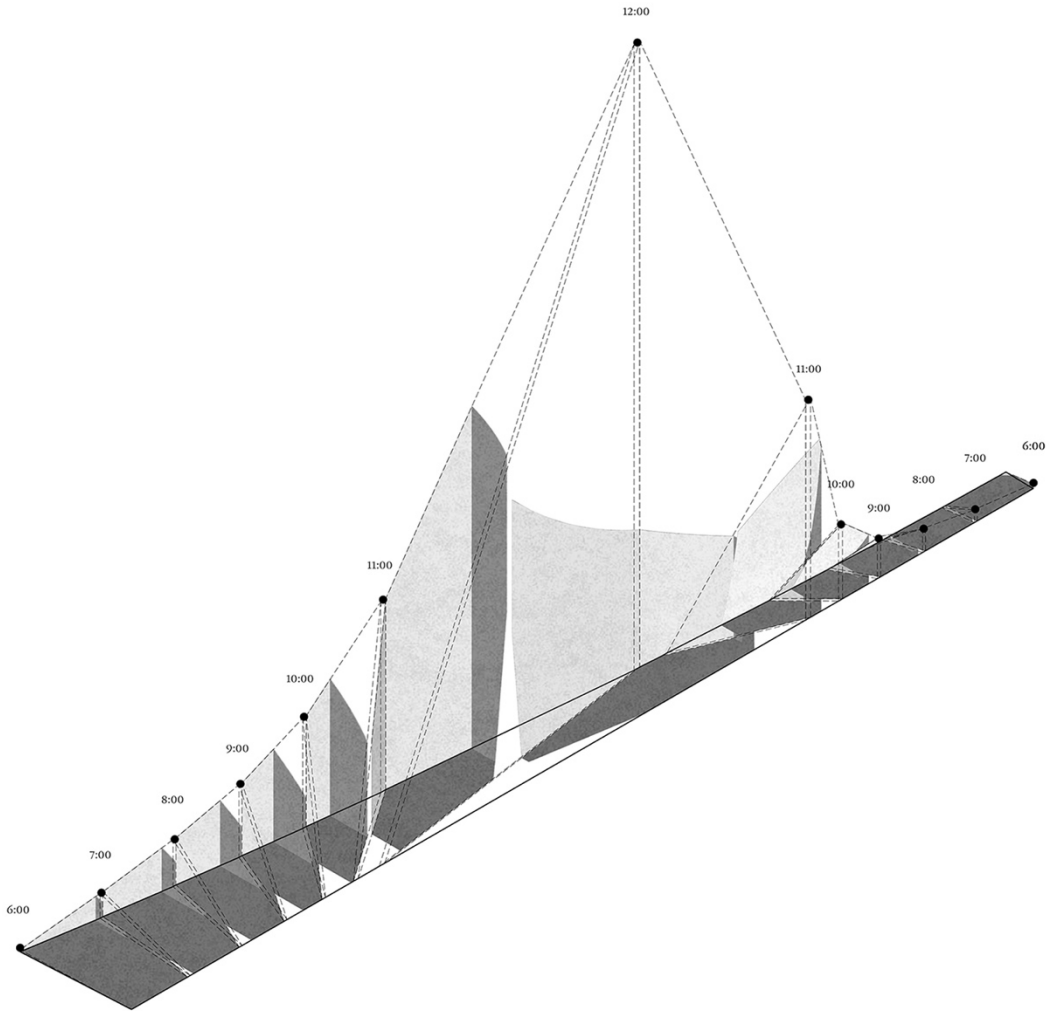

Drawing 4.6 Imprinting the cycle of the full moon onto the station (continued).

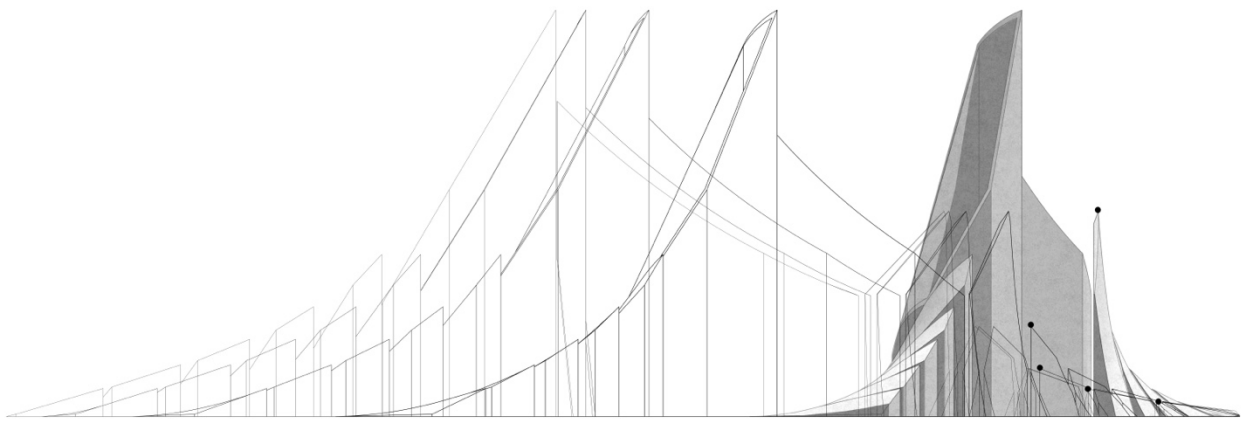

Drawing 4.7 Lunar alignment at the Metonic cycle.

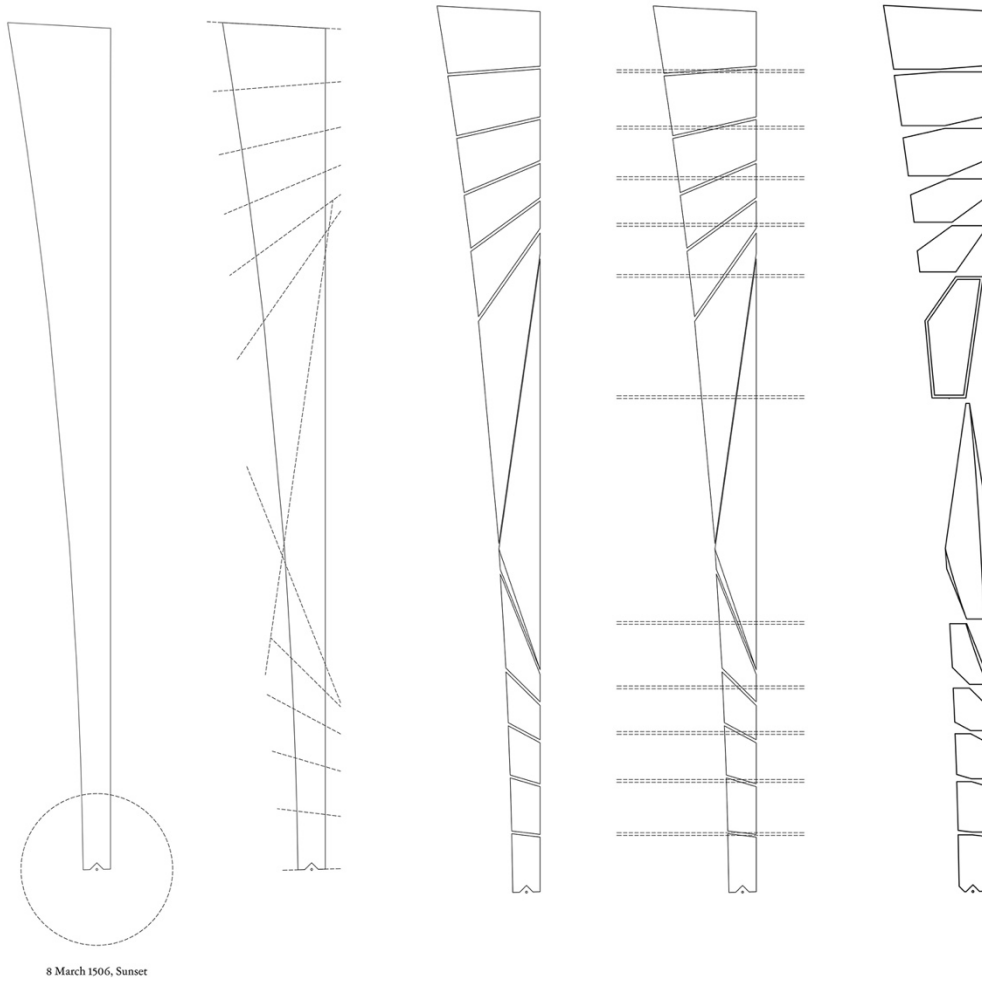

Drawing 4.8 Channeling the cycle of the moon.

d. TARIK AL-NAHR

While the Myth of the Valley makes clear that the survival of a place cannot always, alone, preserve the memory of its people, it is elsewhere on the Path of Nightrise that the very erasure of a site allows for the longevity of its story. *Tarik al-Nabr*, or the River Path, is one such case, and is perhaps best understood with a trip back in time, back before the eruption of tensions along the southern border or the scholarship of the *'ulama* of Jabal 'Amil, long before the Ottomans, the Arabs, Romans, Persians, Babylonians, Assyrians, Egyptians, and even the Phoenicians, to a period when the river bordering the land on which the village of Taibeh currently sits created what Lewis Mumford refers to as 'the magnet,' "a meeting place to which people periodically return."⁵⁰ He writes that "Before the city there was the hamlet and the shrine and the village: before the village, the camp, the cache, the cave, the cairn; and before all these there was a disposition to social life that man plainly shares with many other animal species."⁵¹ It is this disposition, stimulated by the fresh stream and the fertile soil, which must have motivated the land's earliest dwellers to settle on the plane surrounding what would later come to be called the Litani River.

The geographic relationship between river and plane necessitated, in its crudest form, a simple path, one that engraved across the valley the primordial desire to settle. The subsequent transformation of the land from magnet to settlement required, besides access to the river and its fertile soil, innovations in storage space that would allow the new hamlet to store what it collected and harvested. The invention of the container revolutionized the potential of the collective imaginary. It not only altered the configuration of domestic space (the container of humans), but also offered a range of new spatial possibilities to which our cities are forever indebted. Mumford writes:

Mark how much the city owes technically to the village: out of it came, directly or by elaboration, the granary, the bank, the arsenal, the library, the store... These are, after all, but elaborate versions of stone and pottery utensils, vases, jars, cisterns, bins, barns, granaries, and irrigation ditches.⁵² He then concludes...The uniqueness and significance of this contribution has too long been overlooked by modern scholars who gauge all technical advances in terms of the machine.⁵³

⁵⁰ Lewis Mumford, *The City in History: Its Origins, Its Transformations, and Its Prospects*, A Harvest Book (San Diego New York London: Harcourt, Inc, 1989). 10

⁵¹ *Ibid.*, 5

⁵² *Ibid.*, 16

⁵³ *Ibid.*, 16

Of relevance to this story is not just the distinctive contribution of the container, but its relationship to the river and the path. In fact, the transportation of water from the river to the hamlet necessitated, thousands of years ago, a constant collaboration between the newly established path and a micro infrastructure of portable buckets. The path instigated a circulation of containers to and from the river in ways that both required and preserved its existence—cognitively, because of the biological need for water, but also physically, through the steady treads up and down the river that stamped its form into the landscape. In other words, the container and the path owe their existence to each other, and they are both indebted to the river and to the need for that water. It is this primeval relationship between bucket and path that survives, centuries later, in the spirit of today's villagers. So deeply rooted is this relationship in the oral culture of Taibeh that any mention of *Tarik al-Nabr*, or any association of the words *Tarik* (path) and *Nabr*, bring forth the image of the bucket. And what's particularly interesting about this image is how the meaning associated with it shifts at nightrise, when the day makes way for the night. The bucket at night is not a version of its diurnal self, nor is it a replication. It is one that evokes a completely different meaning of the night, one very much other to those that simply treat it as an inferior extension of the day.

The Path and Bucket: A Diurnal Tale

The diurnal tale of the path and bucket once powerfully evoked the image of a communal descent to the river. First in the morning and then in the afternoon, countless buckets were balanced on heads and strapped to the backs of mules in a steady stream of village life that would populate the landscape for centuries until the imposition of the French mandate in 1920. Unlike Zayn al-Din al-'Amili's trip to Taibeh, a visit to which no living person can attest, this descent to the river is one that villagers can remember parents and grandparents making. The diurnal image of *Tarik al-Nabr* thus survives in the minds of the older generation as a remnant of a different time. It does not, however, pulsate in the imagination of the youngest villagers who now have networks of potable water running through their homes and have never needed to collect water at the source.

In fact, nothing threatened this association between the bucket and *Tarik al-Nabr* more than did the construction of the Taibeh Pumping Station in 1952. Today, the station is equipped with a motor so powerful, it channels water to almost every village across Jabal 'Amil. Not only did it revolutionize water collection and transportation, but it also carved out a new road along the valley's edge, one large enough to accommodate the passage of parts needed for the station's construction and maintenance.

Tarik al-Nabr, a delicate footpath that had, step by step, been stamped into the soil for thousands of years, was immediately rendered irrelevant.

As with all other aspects of Taibeh's oral legacy, the story of *Tarik al-Nabr* was also threatened by Israeli occupation. The 1978 invasion of South Lebanon, code-named Operation Litani (River), was carried out by the IDF to occupy all land adjacent to the river. The subsequent displacement of 'Amilis thus came at a time when the practice of toting water along the path was already in decline because of the new pumping station. In the years that followed, the procession of villagers was instead replaced by soldiers, both Israeli and UNIFIL, who occasionally used the path to patrol the surrounding landscape. By the time villagers returned in 2000, wild grass had long since reclaimed the worn earth and the path had all but been lost to history. Other than a series of concrete steps and a ramp that connected the path at its peak to the village, it was as if it had never existed.

If the disappearance of the path first instigated this isolation of village and river, the pollution of the greater Litani has only since reinforced that separation. Its contaminated waters are now channeled underground into the pumping station, alongside all other currents of electricity, sewage, and infrastructure also made to flow beneath the village. Thus does the river join a subterranean network of flows ultimately deemed oppressive to both our eyes and noses. Bryan Palmer frames this natural aversion to these networks as, "the invisibility and filth of the underground, a foundation on which the visibility of civilization rested precariously."⁵⁴ No longer understood by the villagers as a natural stream simply passing through a pumping station, the river is now instead inseparable from the infrastructure – it is just as dirty, mechanical, and unnatural. And if it works, there is no need to remember it.

The Path and Bucket: A Nocturnal Tale

The disappearance of *Tarik al-Nabr*, and by extension, the disappearance of the bucket, traces the gradual transformation of the river from magnet to infrastructure. Although water and fire are usually opposed, particularly by those who make sense of the world in binaries, I am reminded here of how Gaston Bachelard traces the evolution of candle to lamp. He explains that "The flame of a lamp, thanks to man's ingenuity, is now disciplined. It is given completely to its task, both simply and lofty, as giver of light. [...] It would require an entire book to do justice to the transition from cosmology

⁵⁴ Bryan D. Palmer, *Cultures of Darkness: Night Travels in the Histories of Transgression* (New York: Monthly Review Press, 2000). 147

of the flame to the cosmology of light.”⁵⁵ It would similarly require an entire other thesis to do justice to the transformation of water to water channel. Of relevance here though is the double life of the bucket. While it’s diurnal self, embodied by the trek to and from the river is naught but a distant memory, the image of its nocturnal life thrives. Bachelard further reminds us that, “Everything in a house would thereby have its ‘double’, not a nightmare phantom but a kind of ghost that haunts the memory, that revivifies remembrance.”⁵⁶ And at the scale of the village, it is precisely this ghost, the ghost of *Tarik al-Nahr*’s diurnal image, that roams freely at night.

In fact, any conversation about the River Path now evokes something far more imaginative and mystical; it is a story that brings voices to a whisper, an eerie slowness reminiscent of the night itself. Such is the Tale of Three Villagers as it was narrated to me by Abou Akram of Taibeh⁵⁷:

Centuries ago, three young men had missed the village’s collective descent to the river and decided to venture to it in the night instead. They hoisted buckets onto their shoulders and removed their shoes to better feel the imprint of the path in the soil beneath them. As they stepped hesitantly forward, the rushing of water grew more intense, a hint that they were moving in the right direction. After some time however, the noise of the river did not get any louder, and their steep descent did not seem to carry them any closer to the water. It is said that the three villagers walked for hours in endless darkness with the buckets thrown over their shoulders. On and on they trekked until they realized, with a start, that the sound of the river had begun to fade. Surely they would have reached the river by now, even if they had drifted from the path? When even the faintest gurgle of water was no longer audible, they collapsed out of sheer exhaustion. Desperate for warmth and slumber, the trio pivoted back up towards the village. But as they made to step up the mountain, they found themselves back at the beginning of *Tarik al-Nahr*, buckets still empty, right where they had started.

This nocturnal tale is so popular today that any mention of *Tarik al-Nahr* resurrects the distortion of space and time. Equally of interest are the occasional villagers’ trips to the river that purportedly evoke

⁵⁵ Gaston Bachelard, *The Flame of a Candle*, The Bachelard Translations (Dallas: Dallas Institute Publications, 1988). 11

⁵⁶ *Ibid.*, 23

⁵⁷ Abou Akram always offers a story or two with any espresso you purchase from his stand in the village souk.

similar distortions. These kinds of nocturnal adventures have not been affected by the Taibeh Pumping Station or the disappearance of the original path but have instead become a testament to the strength and courage of youth daring to attempt the journey. Although, fear of the river path by night does not stand up to the fear all kids seem to share of their parents finding out about the treacherous excursions. But it is exactly these micro-tales personally narrated by those claiming to have ventured to another realm that only further replenish the potency of the original tale. And so, even after the disappearance of *Tarik al-Nahr*, the nocturnal image of the empty bucket reigns supreme. More interesting still is how the absence of the original path and the night are both linked through the narrative of the unseen. While the disappearance of the path completely jeopardized the image of a lively procession of water bucks, it has also inadvertently made the invisible shadow of this path far more meaningful, and far more present. It is only through this other form that the path continues to exist today in a way that alters the materiality of the night around it. The night around the original imprint is of a different quality: it is thicker, eerier, and more mystical. It is a portal to another dimension.

The arcane finds its way into the tale of *Tarik al-Nahr* via the Jinn of *Jabal Qaf*, the only way the people of Taibeh make sense of the spatial and temporal distortions invoked by those venturing to the river at night. Attributed to free-willed genies known to play tricks on humans, these Jinn are said to be neither angel nor demon, but a third category of beings that roam in nations and tribes⁵⁸. Although it is impossible to do justice to the complexity of the Jinn and *Jabal Qaf* within this thesis alone, what is of relevance here is that they, like nightrise, are not confined to normative binaries. The Qur'an, which addresses both humans and Jinn— and considers them to be the only other intelligent beings on earth⁵⁹ – mentions on several occasions the physical composition of the Jinn: 'Surely, We created mankind of a clay of mud molded, and the Jinn created We before of scorching winds.' (Qur'an 15:26-27)⁶⁰. Elsewhere, there is also a mention of "smokeless fire" (Qur'an 55:14-15)⁶¹. In discussing the relationship between humans and the Jinn, Amira El-Zein writes, "Both species are at liberty to group, to trust or distrust the Word of God, and to religiously differ"⁶² and yet "although the subtle Jinn can see humans and intervene in their lives, the latter cannot perceive them in the manifest realm [...]"⁶³.

⁵⁸ Jinn can belong to either of seven different categories: the Ghoul, the Hinn, the 'Ifrit, the Marid, the Nasnas, the Shiqq, and the Si'lat.

⁵⁹ El-Zein, *Islam, Arabs, and the Intelligent World of the Jinn*. X

⁶⁰ Ibid., 33

⁶¹ Ibid., 33

⁶² Ibid., 15

⁶³ Ibid., 22

In fact, the term Jinn itself refers to all invisible spiritual entities. El-Zein notes: “each time the two Arabic letters Jim and Nun occur together, they carry the meaning of invisible, hidden, and mysterious.”⁶⁴

Such fuels the human fear of Jinn, particularly within the context of *Tarik al-Nabr*. These are creatures that operate in a different realm, completely unperceived, with intentions we cannot decipher. It is interesting to note that while there are said to be good and bad Jinn, their reputation as cunning beings speaks to our tenuous relationship with the unseen. If we hardly trust each other as humans, how do we trust what we cannot even see? It is this very tension that makes relevant the superposition of the world of the Jinn onto the story of *Tarik al-Nabr*. The Prophet Mohammad reminds us that “God divided the Jinn and the humans into ten parts. One part makes up the human race, and the other nine are made up of Jinn.”⁶⁵ In this hierarchical organization of the cosmos, the imaginal realm exists just above our terrestrial domain and interferes in our lives in ways we cannot understand⁶⁶. It is neither a place nor the absence of one; it is both material and immaterial, answering to its own rules and logic. It is the realm of *Jabal Qaf*, the embodiment of this intermediary dimension, the space separating the material world from that of the spiritual.

There is perhaps no one better to explain the relationship between the imaginal realm and *Jabal Qaf* than Henry Corbin. He first coined the term imaginal, or *mundus imaginalis*, by examining the writings of Suhrawardi, specifically the tale of The Crimson Archangel (also known as The Red Intellect). He writes:

At the beginning of the tale that Sohravardi entitles "The Crimson Archangel," the captive, who has just escaped the surveillance of his jailers, that is, has temporarily left the world of sensory experience, finds himself in the desert in the presence of a being whom he asks, since he sees in him all the charms of adolescence, "O Youth! where do you come from?" He receives this reply: "What? I am the first-born of the children of the Creator [in gnostic terms, the *Protoktistos*, the First-Created] and you call me a youth?" There, in this origin, is the mystery of the crimson color that clothes his appearance: that of a being of pure Light whose splendor the sensory world reduces

⁶⁴ Ibid., 34

⁶⁵ Ibid., 75

⁶⁶ Ibid., 13

to the crimson of twilight. "I come from beyond the mountain of Qaf... It is there that you were yourself at the beginning, and it is there that you will return when you are finally rid of your bonds." The mountain of Qaf is the cosmic mountain constituted from summit to summit, valley to valley, by the celestial Spheres that are enclosed one inside the other. What, then, is the road that leads out of it? How long is it? "No matter how long you walk," he is told, "it is at the point of departure that you arrive there again," like the point of a compass returning to the same place. [...] We observe immediately that we are no longer reduced to the *dilUmma* of thought and extension, to the schema of a cosmology and a gnoseology limited to the empirical world and the world of abstract understanding. Between the two is placed an intermediate world, which our authors designate as *'alam al-mithal*, the world of the Image, *mundus imaginalis*: a world as ontologically real as the world of the senses and the world of the intellect, a world that requires a faculty of perception belonging to it, a faculty that is a cognitive function, a noetic value, as fully real as the faculties of sensory perception or intellectual intuition. This faculty is the imaginative power, the one we must avoid confusing with the imagination that modern man identifies with "fantasy" and that, according to him, produces only the "imaginary." [...] Certainly, there may be topographical correspondences between the sensory world and the *mundus imaginalis*, one symbolizing with the other. However, there is no passage from one to the other without a breach. Many accounts show us this. One sets out; at a given moment, there is a break with the geographical coordinates that can be located on our maps. But the "traveler" is not conscious of the precise moment; he does not realize it, with disquiet or wonder, until later. If he were aware of it, he could change his path at will, or he could indicate it to others. But he can only describe where he was; he cannot show the way to anyone.⁶⁷

So striking are the parallels between *Tarik al-Nabr*, a path said to plant villagers back where they started, and *Jabal Qaf*, where any journey leads back to the point of departure "like the point of a compass returning to the same place,"⁶⁸ that one can easily appreciate how closely the two stories have come to be associated. The warping of spacetime along *Tarik al-Nabr* is an exact manifestation of what

⁶⁷ Henry Corbin, *Mundus Imaginalis: Or, The Imaginary and the Imaginal* (Ipswich: Golgonooza Press, 1976). 7-8

⁶⁸ Yaḥyá ibn Ḥabash Suhrawardī and Henry Corbin, *L'archange empourpré: quinze traités et récits mystiques*, Documents spirituels; 14 (Paris: Fayard, 1976). 227-239

Corbin refers to as the breach, “a break with the geographical coordinates that can be located on our maps,”⁶⁹ to reveal a passage. *Tarik al-Nabr* then, for the people of the village, exists simultaneously in the terrestrial and the imaginal realms, within both the material and immaterial dimensions. In other words, it is at the intersection of *Jabal Qaf*, the cosmic mountain, and the valley of Taibeh, where the Path of Nightrise itself flows. A portion of it too, then, also exists at the intersection of two notable mountains, *Qaf* and *‘Amil*, both of which relate in their own ways to Shi’i lore and identity: *Jabal Qaf*, the land of the hidden Imam and the kingdoms of the Jinn⁷⁰, and *Jabal ‘Amil*, the land of the great *‘ulama*. This intersection prevails long after the imprint of the River Path has been swallowed by the valley. It is precisely this idea, that of the invisible yet unobstructed passage into the realm of the Jinn, that strikes fear into the hearts of those old enough to mistrust the unseen, those whose experiences and cultures have taught them to fear the darkness.

As aforementioned, the Path of Nightrise actively escapes and avoids the unidirectional line, that which produces a binary between what is walkable and what is not— itself a recollection of the strict separation of day and night. Instead, and in the spirit of the night, it scatters enough elements to allow each traveler to conjure a path through the power of their own minds, a path that recognizes and invokes the gradual transformation and various shades of darkness. While this treatment of nightrise is manifested along the entirety of the path, and has been captured uniquely by each station, it is especially relevant here, where the Path of Nightrise summons the ancient *Tarik al-Nabr*. The intersection between the two paths, and by extension, between the valley in Taibeh and the kingdoms of the Jinn on *Jabal Qaf*, is the interest of this third station.

The station dedicates itself to the Tale of the Three Villagers, to *Jabal Qaf* and the kingdom of the Jinn, and more specifically, to the distortion of space and time bestowed upon those who surrender to the unseen. But how can it pay tribute to its position at the intersection of *Jabal Qaf* and the path for nightrise? How can it exist, simultaneously, in the material and imaginal realms? And how can it make use of nightrise and the spectacle of darkness to manifest this tribute?

⁶⁹ Corbin, *Mundus Imaginalis*. 8

⁷⁰ The hidden Imam is the twelfth and final Imam, Muhammad al-Mahdi, a major figure in Shi’i Islam. Twelver Shi’i doctrine holds that the Twelfth Imam did not die but went into a spiritual form of existence known as occultation and will return at the end of time as a messianic Mahdi to restore justice and equity on earth. Corbin writes, “Since then, the Hidden Imam is in the position of those who were removed from the visible world without crossing the threshold of death: Enoch, Elijah, and Christ himself, according to the teaching of the Qur’an. He is the Imam ‘hidden from the senses, but present in the heart of his followers,’ in the words of the consecrated formula, for he remains the mystical pole [qotb] of this world, the pole of poles, without whose existence the human world could not continue to exist.

In embracing its significance as a vessel of the two realms, the station first defines the edges of the intersection between *Jabal Qaf* and the Path of Nightrise at points A and B. These edges behave differently across the imaginal and terrestrial realms. Because *Jabal Qaf* always returns travelers to the initial point of departure, it then follows that on the mystical mountain, the beginning is also the end, that points A and B are essentially one and the same [Drawing 5.1]. It is precisely this tension between the duality of the station in the terrestrial realm and its singularity in the imaginal realm that is at stake here. In other words, and to perpetuate the metaphor of Suhrawardi, it is one unique station, just like the singular needle of a compass, but is manifested as two stations in our material world— as either edge of that same needle. This station must be understood as a tribute to the beginning (and end) of the intersection. But in this particular case, it is light that distorts the truth and creates a mirror image of what in the imaginal realm is a singular entity. Nightrise here erases the mirror image, erases the dual edges of the intersection, and allows us to plunge deep enough into it to locate truth.

That is not to say that during the day the station cannot also be made to embody the intersection of the two worlds. In fact, it is precisely this duality that determines its composition. Although during the day it cannot transport the traveler to the imaginal realm, it can at least declare its capacity as a double gate, a portal to the river but also to *Jabal Qaf*. This duality is made manifest by the lag between the passage of time in our terrestrial realm [Drawing 5.2] and the passage of time in *Jabal Qaf* [Drawing 5.3]. Because *Jabal Qaf* is the axis mundi of the world and exists at the center of the universe, it becomes possible to calculate the passage of time there. Every beginning on *Jabal Qaf* is also an end. That too holds true for every sunrise and sunset. Because the mountain is at the world's center, the sun circles its summit only to set where it rose in the first place⁷¹. This is detailed in Bundahishn's account of Mount Alburz, another name for *Jabal Qaf*:

Of Mount Alburz it is declared, that around the world and Mount Terak, which is the middle of the world, the revolution of the sun is like a moat around the world; it turns back in a circuit owing to the enclosure (var) of Mount Alburz around Terak. As it is said that it is the Terak of Alburz from behind which my sun and moon and stars return again. For there are a hundred and eighty apertures (rojin) in the east, and a hundred and eighty in the west, through Alburz; and the sun, every day, comes in

⁷¹ This is unlike how, in our material world, the sun rises in the east and sets in the west.

through an aperture, and goes out through an aperture; and the whole connection and motion of the moon and constellations and planets is with it: every day it always illumines (or warms) three regions (karshwar) and a half, as is evident to the eyesight.⁷²

Through the lens of someone in the terrestrial realm, then, time on *Jabal Qaf*, which answers to a different revolution of the sun and the planets, is quite different. This difference is captured by the fourth drawing [Drawing 5.4], which visualizes the difference in movement of the shadows between a sundial in Taibeh and another on *Jabal Qaf* [Drawings 5.5, 5.6, 5.7, and 5.8]. This lag is captured by the station itself, a gate formed by the juxtaposition of the two timepieces. At any point of the day, a traveler can observe the passage of time in both realms by reading the lag between the two shadows. But this movement of shadows disappears with the rise of night, when the station must express its location through other, non-ocular means. By day, the station thus exists as a premonition of the unseen. The disappearance of the ocular, translated by the gradual arrival of night and the fading of temporal lag, announces the immeasurable distortion of time, a warping that no graph or diagram can logically quantify.

Thus does the station announce the gradual opening of the passage to the imaginal realm in celebration of the spectacle that is nightrise. The station here embraces its role as collaborator with the Jinn, a co-conspirator that works to amplify how we might experience that intersection. In doing so, it celebrates the rite of passage to another dimension. This ritual begins at nightrise, when the prevailing winds begin to shift from the southwest to the northeast,⁷³ and into the station's windcatcher. With openings only on its northern and eastern faces, this windcatcher is designed to only receive the wind at night. Once captured by the station, the winds are then redirected towards the Night-Blooming Jasmine concealed within it⁷⁴ [Drawing 5.9]. This particular tree, much like the portal to the imaginal realm, only blossoms at night. Its flowers' fragrance, said to be the world's most potent, can extend as far as 300-500 ft away from the tree⁷⁵. Only at night, when the winds are channeled through the station, does it perfume the portal and the area around it. But the choice of this particular plant is not solely based on its nocturnal nature. In fact, among the spiritual beliefs associated with Jasmine, is a conviction among Muslims that Jinn are attracted to the plant's heady and perhaps intoxicating fragrance.

⁷² Edward William West, *Pablavi Texts* (London: Forgotten Books, 2015). 22

⁷³ The shift in winds depends on the season.

⁷⁴ Night-Blooming Jasmine is also known as the Lady of the Night

⁷⁵ <https://dengarden.com/gardening/Night-Blooming-Jasmine-Cestrum-Nocturnum>

A small wooden plank hinged to the walls of the windcatcher is designed to beat against the structure in tandem with the passage of wind in the night. Wood, wind, and tree together proclaim the presence of *Qaf*, the knocks calling out the “Qa” while the rustle of Jasmine sings out the “F.” On the windiest nights, *Jabal Qaf* consumes the entirety of the valley in a medley of scent and sound. The station here alerts travelers of their proximity to the mysterious mountain, much like how Shaykh Nasr in *The Arabian Nights* cautions, ‘Know, O my child, that thou art near the mountain Qaf, and there is no departing for thee from this place till the birds come [...]’⁷⁶

And so, what by day appears to be two monolithic gates on either edge of an inconsequential intersection, transforms by night into a portal to a world beyond the valley. It is as travelers wander slowly away from the perfumed land that the call to *Jabal Qaf* grows faint. Only when they have travelled enough do both smell and sound gradually reappear to announce the intersection’s end. The beginning is the end, and the end is the beginning. Here, the two monoliths of the day merge in the night in favor of this single moment, experienced in total unity.

⁷⁶ Richard Burton, *The Thousand Nights and One Night*, vol. 5 (New York: Heritage Press, 1934).



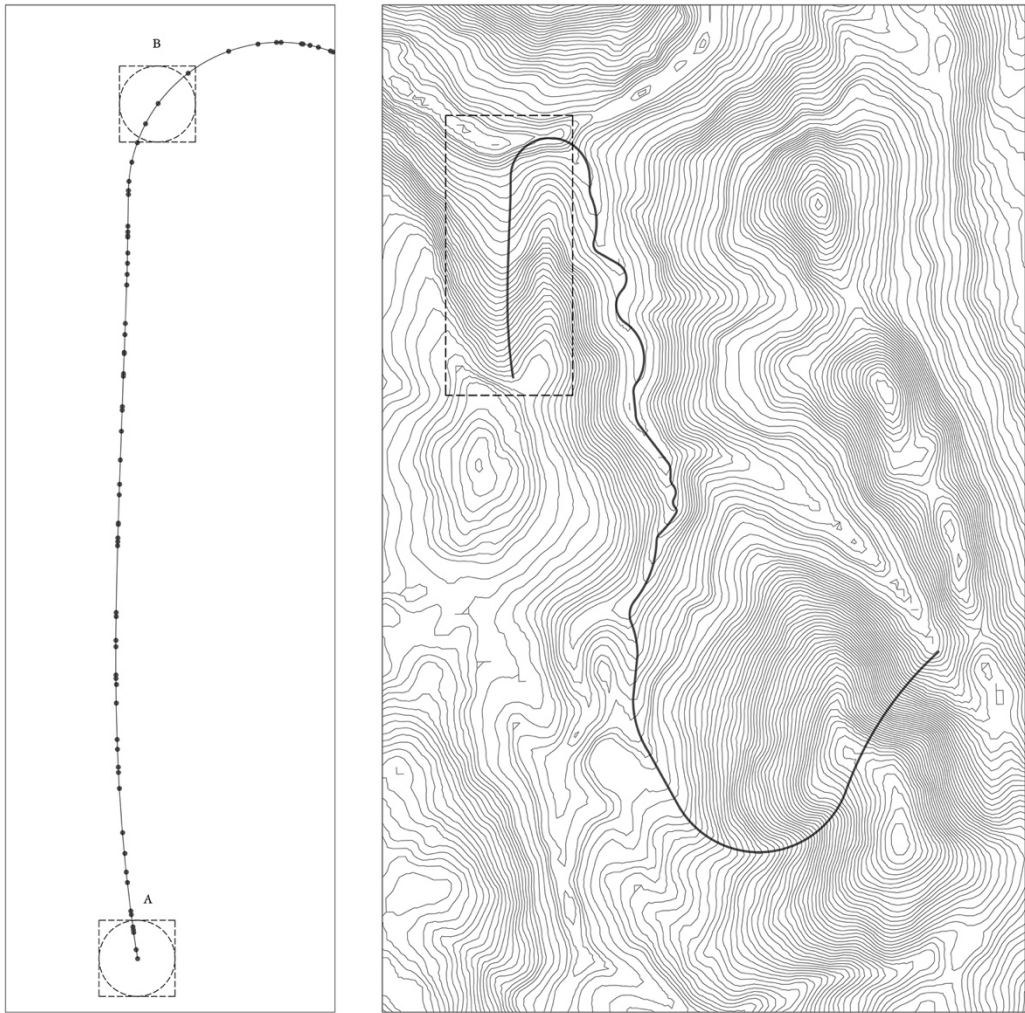

Drawing 5.1 The old *Tarik al-Nahr*.

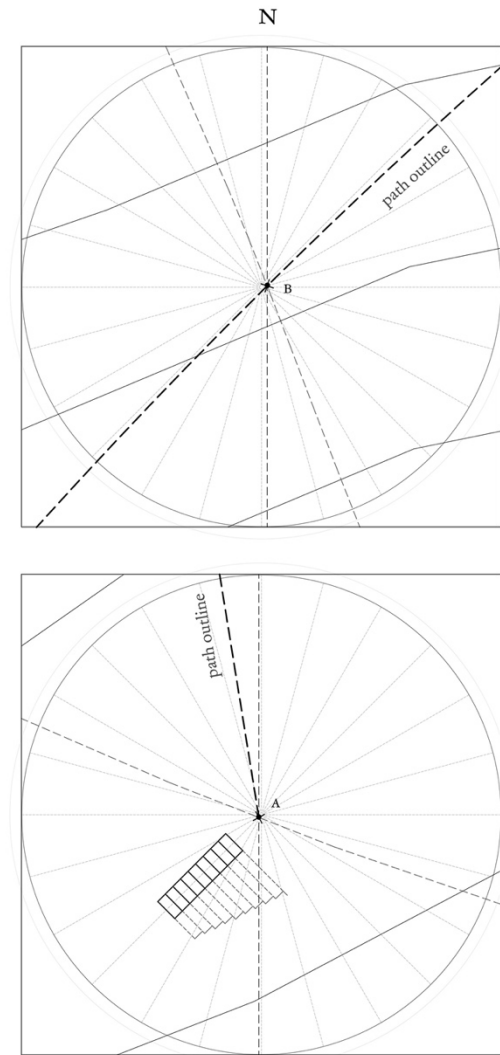

Drawing 5.1 (continued) The boundaries of the old path as potential temporal gates.

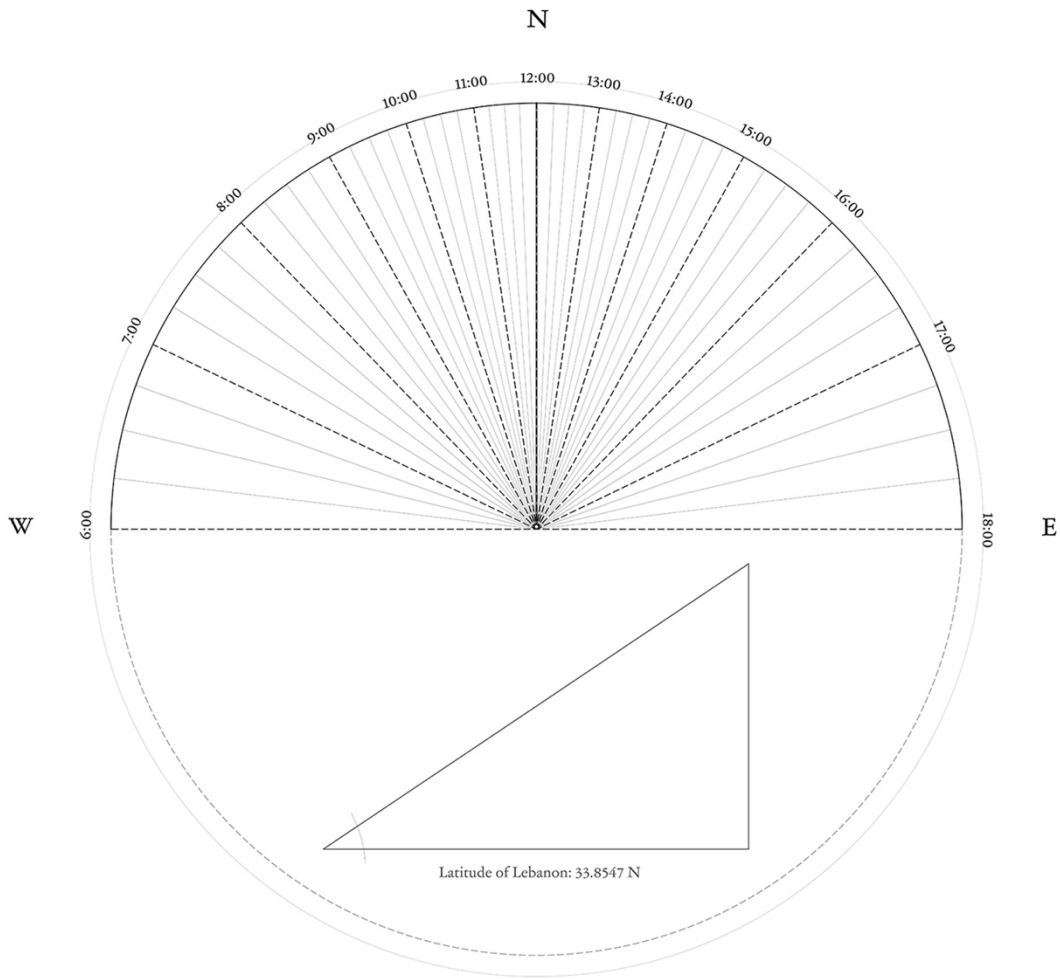

Drawing 5.2 Passage of time in the terrestrial realm.

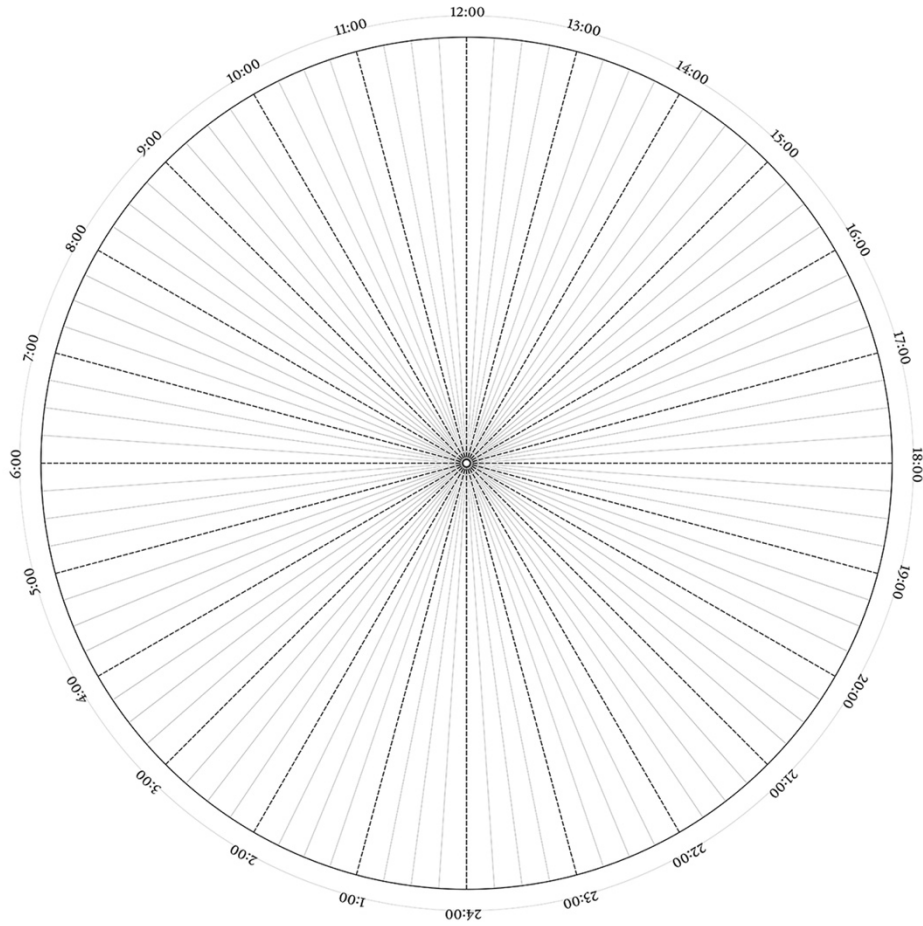

Drawing 5.3 Passage of time on *Jabal Qaf*.

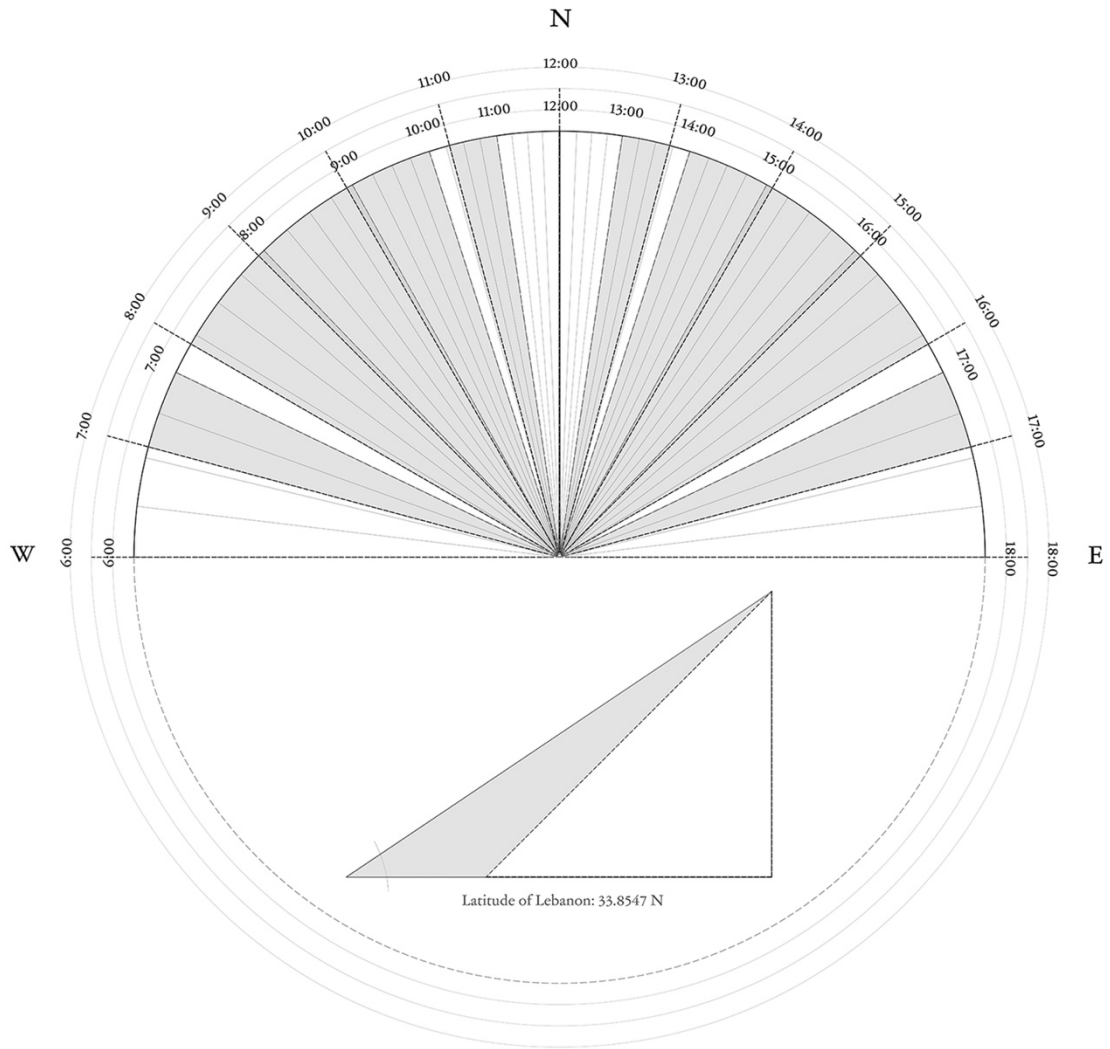

Drawing 5.4 Time lag between the terrestrial realm and *Jabal Qaf*.

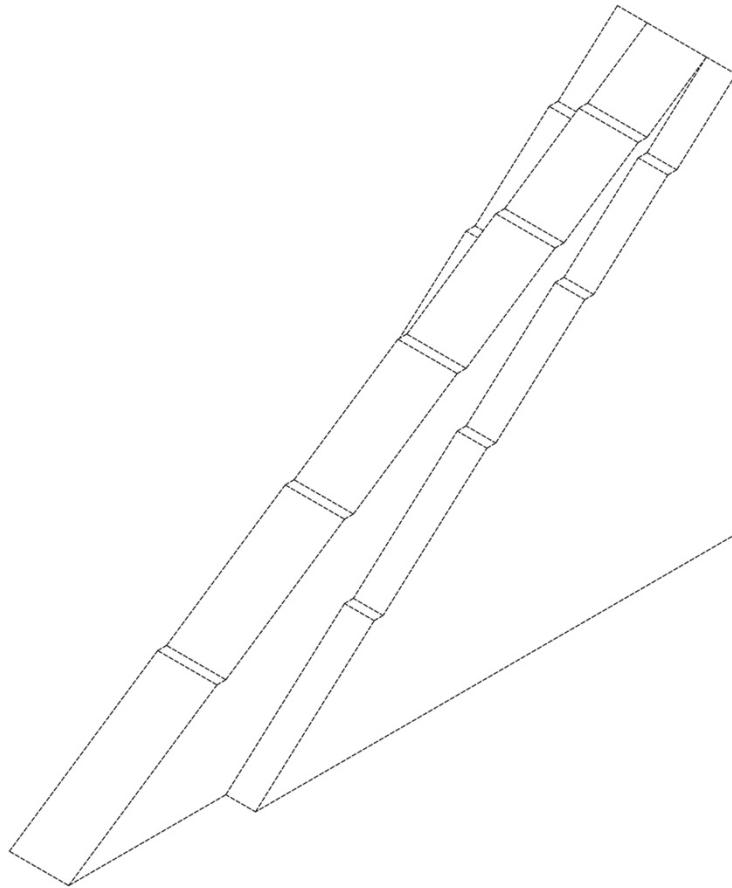

Drawing 5.5 The station is composed of a hybrid of the two sundials.

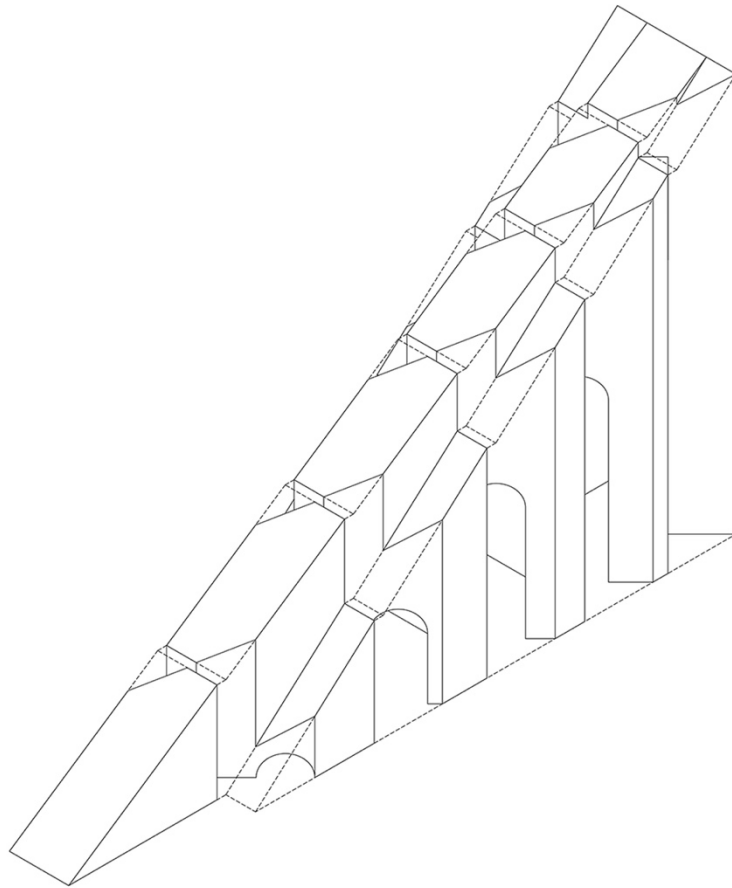

Drawing 5.6 Transformation of the station into a gate.

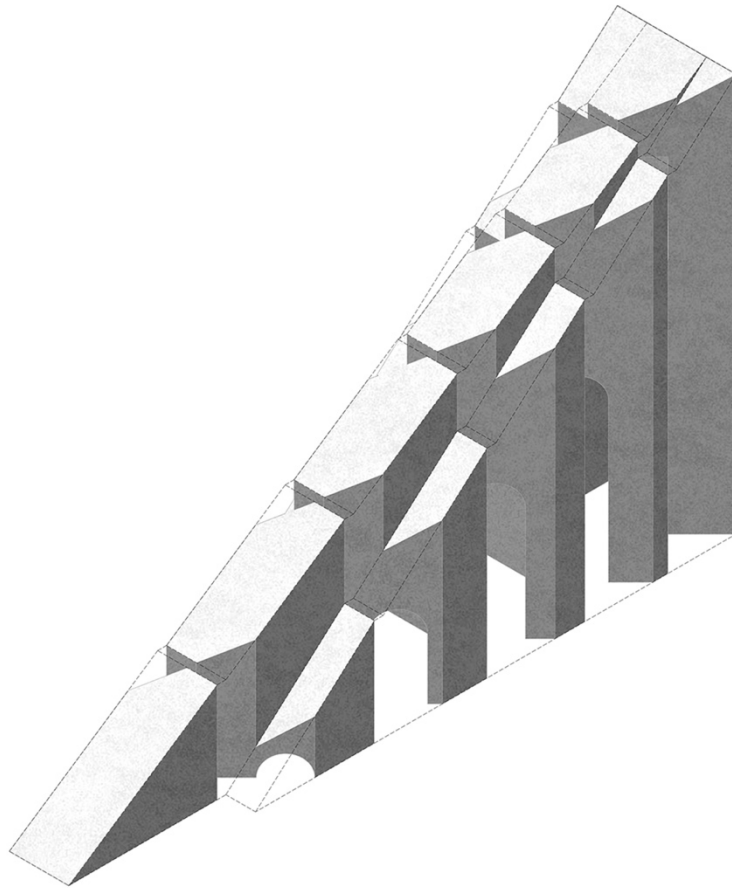

Drawing 5.7 Transformation of the station into a gate (continued).

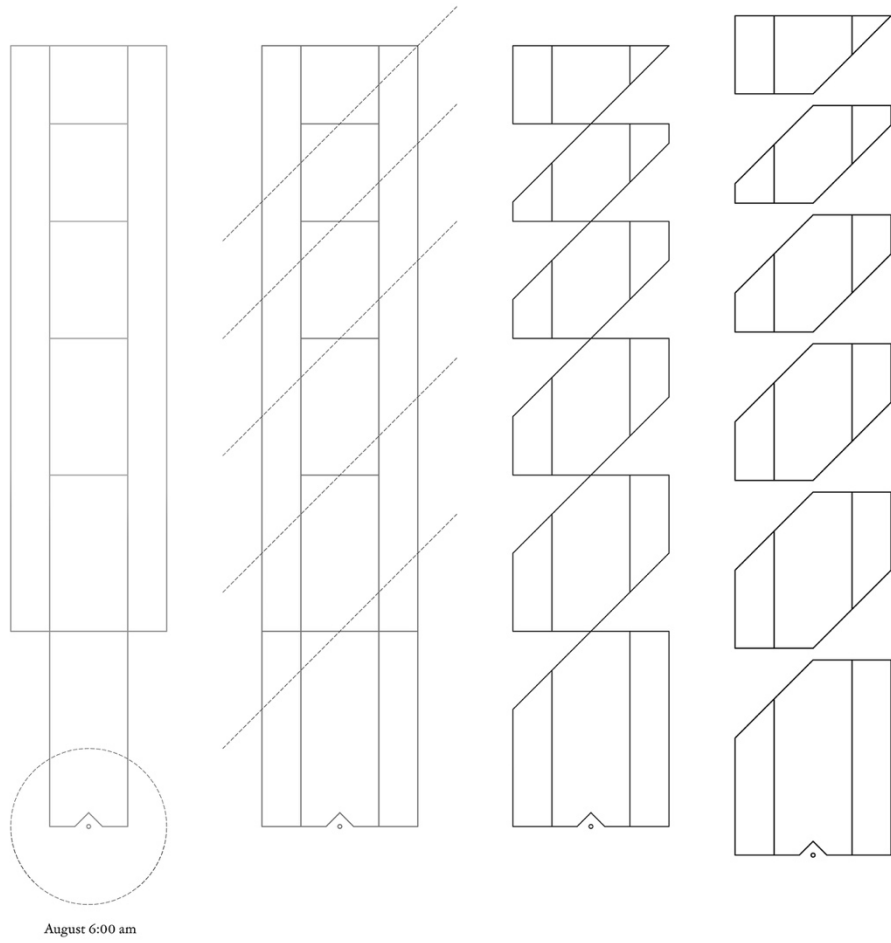

Drawing 5.8 Transformation of the station into a gate (continued).

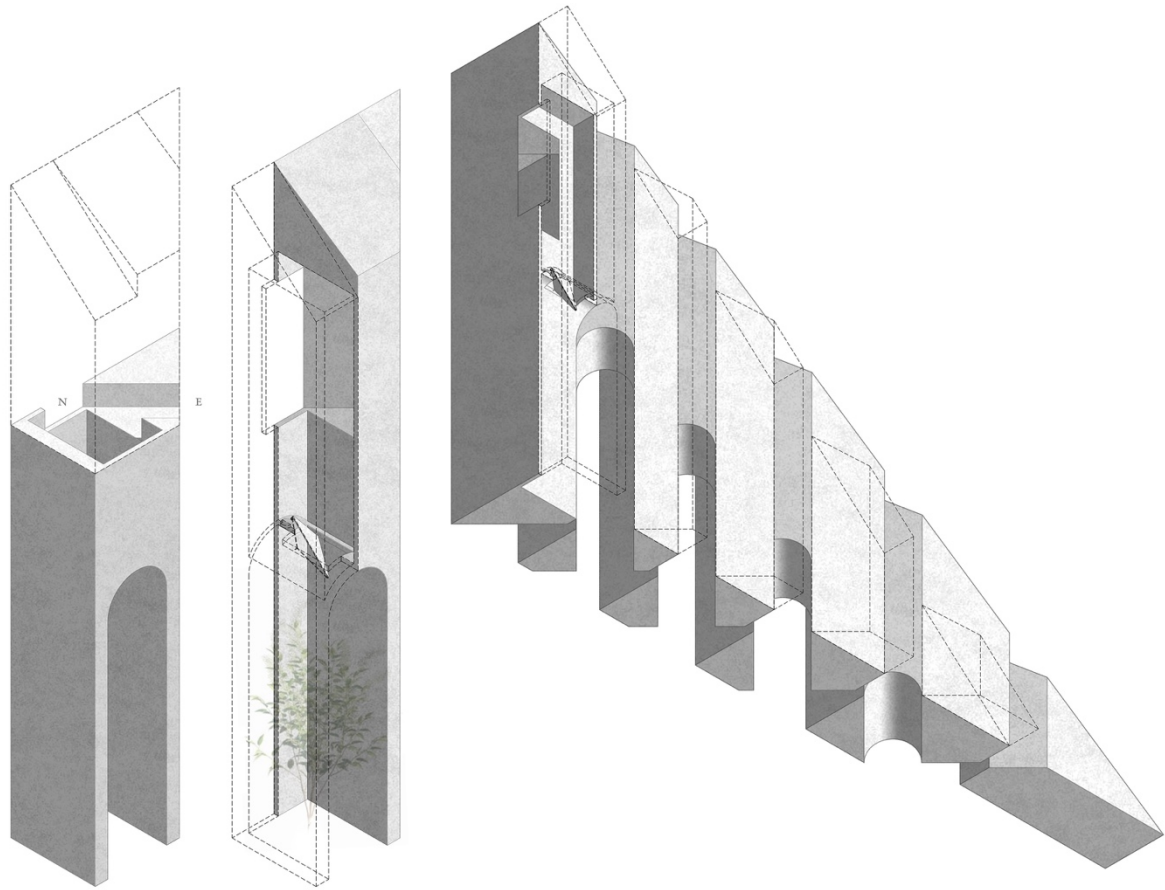

Drawing 5.9 Calling *Jabal Qaf*.

e. THE CAVE

The ways in which the villagers of Taibeh resist Jabal ‘Amil’s intellectual decline has been embodied by a number of key stories thus far. Tales like the Myth of the Valley, for example, resurface key contributions Taibeh has made to the mountain’s scholarly and literary production. However, it is the proverb “Look under any stone in Jabal ‘Amil and you will find a poet,” that has perhaps best rallied the mountain’s many villages behind a banner of resistance, and it is precisely the space under that stone that is essential to this conversation. But what truly lingers beneath that stone? Or rather, what becomes of the complete and total darkness that the stone, undisturbed, at first provided? And how is that darkness integral to the discovery of the poet? For in searching for the poet, we are commanded to seek darkness, not attempt to eliminate it. Key here then is the directive to “look,” and our natural inclination to lift the stone to do so. Instead, we are asked to adjust our senses in pursuit of the unseen, to dive *under* the stone and surrender to the promise of finding a poet. Should we choose to journey beneath the stone and embark on the search for them, we must agree to do it blindly.

It was with two golden pins from his mother’s dress that Oedipus, the mythical King of Thebes, blinded himself upon discovering that his birth prophecy had been fulfilled, that he had indeed, albeit unwittingly, murdered his father and married his mother, Queen Jocasta. Guilty of both incest and patricide, his self-inflicted blindness is the result of his unbearable shame⁷⁷. Oedipus, whose vision had deprived him of the truth he was too proud to see, chooses blindness as his ultimate penance. It is in *Macbeth* that this relationship between shame and the violent gouging of the eyes brings forth the rising of the night: “Come, seeling night, scarf up the tender eye of pitiful day”⁷⁸. Here, seeling refers to the language of falconry and the practice of sewing a hawk’s eye shut to domesticate it⁷⁹. In appealing to the blindness of the night, Macbeth hopes to conceal that he ordered the murder of his son and Banquo. It is precisely the nature of this blindness, presented as both gift and violent tragedy, that also influences the decision of Master Osman in Orhan Pamuk’s *My Name is Red*. In his pursuit of the “divine blackness of the blind,” the head miniaturist puts a needle to his eyes and rejects the mundane nature of the world around him⁸⁰. It is through this lens that I attempt to pay tribute to the blindness that overtakes us beneath the stone; a burden with exceptional rewards that many would prefer not to receive.

⁷⁷ Sophocles, David Grene, and Sophocles, *Oedipus the King* (Chicago; London: The University of Chicago Press, 2010).

⁷⁸ William Shakespeare, *Macbeth*, Dover Thrift Editions (New York: Dover Publications, 1993).

⁷⁹ Nina Edwards, *Darkness: A Cultural History* (London, UK: Reaktion Books Ltd, 2018). 84

⁸⁰ Orhan Pamuk and Erdağ Göknar, *My Name Is Red*, 1st Vintage International ed (New York: Vintage International, 2002). 326

This blindness, the proverb promises us, conceals a poet under any stone, no matter its type, shape, size, or location, as long as it exists somewhere in Jabal ‘Amil. So captivating is this invitation, so simple and yet so complicated, that my return to Lebanon in March, seven months after the start of my walk, saw me venture immediately to the valley of Taibeh in search of a stone, one that could initiate dialogue between the Path of Nightrise and my search for a poet. I walked through the valley for hours, stopping to inspect each and every stone along the way—crouching, kneeling, squatting, and lying flat on my stomach in an effort to catch a glimpse of the darkness beneath. I am not so sure what I expected to find but am grateful that the irrationality of my search escaped me at the time.

It was only when I was looking elsewhere that I found it.

The search for the stone, I came to realize, was in itself a testament to the authority of blindness. This is not unlike the pilot in *The Little Prince* who, after repeatedly failing to draw the prince a sheep, draws him a box instead and explains that the sheep is inside it. “That is exactly the way I wanted it!” said the little prince⁸¹. And if the valley itself was the pilot, relentlessly offering me stones to choose from, then the only stone I wanted was the one that lived in the darkness of my imagination. But this darkness, much like the lines of the pilot’s box, required a vessel to embody it. And nothing stirred alive my imagination more than did a little pebble at the valley’s uppermost edge. It was only when I lowered my head to contemplate the space below it, when I bowed an ear to the cold earth of the great mountain, that I recalled the proverb and the freedom it offers. *Any stone in Jabal ‘Amil, of any type, shape, or size*. Is the great mountain beyond the valley not simply just the largest of stones? What then, lies beneath it?

The space beneath the mountain is foundational to both Islamic thought and literature. And there is perhaps no greater example than the cave of Hira at the heart of *Jabal al-Nour* near Mecca. It was there that the Prophet Muhammad often meditated in solitude, and it was during one such meditation that the Angel Gabriel appeared before him and proclaimed, “*Iqra,*” or, “Read.”⁸² This marked the first day of the Prophet’s revelation. That darkness is a requisite for enlightenment is essential here and is further acknowledged by the contrast between the dark cave and the name of the mountain under which it sits, *Jabal al-Nour*, also known as the Mountain of Light or the Hill of Illumination. But while the location of the cave of Hira is uncontested, the Qur’an speaks of another cave that has been

⁸¹ Antoine de Saint-Exupéry and Richard Howard, *The Little Prince*, 1st ed (San Diego: Harcourt, 2000). 14

⁸² *Iqra* is alternately also translated as “Recite!”

associated with various other mountains. Its true location has long since been the subject of great speculation, as is evidenced by the numerous caves, shrines, and pilgrimage sites dedicated to it around the world⁸³. Such is the story of the Companions of the Cave, *Ashāb al-kaḥf*, which features in the eighteenth surah of the Qur'an, *Sūrat al-kaḥf*. The story itself is a rendition of the early Christian legend of the Seven Sleepers of Ephesus. In *Stephen of Ephesus*, Ernest Honigmann summarizes the narrative as follows:

The Emperor Decius (249–51) comes to Ephesus to revive there the worship of idols and enforce his laws against the Christians. Seven young men who live in the imperial palace – their names are given in many variants – refuse to sacrifice before the idols. The emperor brings them to trial but, being about to leave Ephesus, he grants them a short time for reflection until his expected return. They leave the city and hide in a cave in a neighboring mountain, the name of which is also given in many different variants, where they prepare for death, absorbed in prayers, and finally fall asleep. After his return to Ephesus, Decius summons their parents and learns from them where they are hidden. He orders his soldiers to close the cave up with large stones to bury them alive. After three hundred seventy-two years (in most versions), in the thirty-eighth year of the Emperor Theodosius II, a heresy breaks out under the leadership of Theodore, Bishop of Aegeae, who denies the bodily resurrection of the dead. At this time Adolius, the proprietor of a field adjacent to the cave of the Seven Sleepers, wants to build a sheepfold. His masons use the stones which close the entrance of the cave. It is thus reopened, and God awakens the youths, who think they have slept only one night. One of them is sent by his companions down to Ephesus in order to buy food and to inquire whether Decius had yet returned. He is amazed to see crosses placed over the city's gates and everywhere. When he buys bread and pays for it with coins of Decius' time, the market-people suppose that he has found an old hoard. They bring him before the bishop and the prefect, who question him. As soon as he has reported the whole story, the bishop understands at once that they had been asleep since the time of Decius. The Emperor Theodosius, informed of the miracle, comes himself to Ephesus where the saints

⁸³ Christian Krokus, "The Darkness Is Not Death: Toward A Christian-Muslim Comparative Theological Study of the Seven Sleepers of Ephesus," *Spiritus: A Journal of Christian Spirituality* 17, no. 1 (2017): 40–59. 45

tell him their story; after this, they fall asleep in death. The emperor sets all prisoners free, gives plentiful alms to the poor of the city, “and a great gathering of bishops takes place.” A basilica is built over the cave, and every year the feast of the Seven Sleepers is celebrated.⁸⁴

But there are many notable differences between the legend of the Seven Sleepers and the story of the Companions of the Cave, *Ashāb al-Kahf*. A translation of the Qur’anic verses is provided below:

[9] Dost thou reckon that the Companions of the Cave and the Inscription are a marvel among Our signs? [10] When the youths took refuge in the cave, they said, “Our Lord! Grant us mercy from Thy Presence, and make us incline to sound judgment concerning our affair.” [11] So We placed [a veil] over their ears in the cave for a number of years. [12] Then We raised them up again, that We might know which of the two parties had best calculated how long they had tarried. [13] We recount their story unto thee in truth. Verily they were youths who believed in their Lord, and We increased them in guidance. [14] And We fortified their hearts. When they arose, they said, “Our Lord is the Lord of the heavens and the earth. We call upon no God apart from Him, for then we would have certainly uttered an outrage. [15] These, our people, have taken gods apart from Him. Why do they not bring a clear authority concerning them? For who does greater wrong than one who fabricates a lie against God? [16] And when you have withdrawn from them and all that they worship save God, then take refuge in the cave. Your Lord will spread forth something of His Mercy for you, and make you incline to ease in your affair.” [17] Thou wouldst have seen the sun when it rose, slanting away from their cave to the right; and when it set turning away from them to the left, while they were in an open space within it. That is among the signs of God. Whomsoever God guides, he is rightly guided; and whomsoever He leads astray, thou wilt find no protector to lead him aright. [18] Thou wouldst have thought them awake, though they were asleep. And We turned them to the right and to the left, with their dog stretching forth his paws at the threshold. Hadst thou come upon them, thou wouldst have turned away

⁸⁴ Ernst Honigmann, "Stephen of Ephesus (April 15- 448 - October 29, 451) and the Legend of the Seven Sleepers." *Patristic Studies*, vol. 173 (1953): 125-168.

in flight and been filled with terror on their account. [19] And in this way We raised them up again, that they might question one another. One of them said, “How long have you tarried?” They said, “We have tarried a day or part of a day.” They said, “Your Lord knows best how long you have tarried. So send one of you with this money of yours into the city, and let him observe which of them has the purest food and bring you some provision therefrom. Let him be discreet and make no one aware of you. [20] Verily, if they come to know of you, they will stone you, or make you revert to their creed, and then you will never prosper.” [21] And in this way We caused them to be discovered, that they might know that God’s Promise is true, and that there is no doubt about the Hour. When they were disputing among themselves about their affair, they said, “Erect a building over them; their Lord knows them best.” Those who prevailed over their affair said, “We shall build a place of worship over them.” [22] They say: “[They were] three, and the fourth was their dog” – guessing at the unseen. And they say, “Seven, and the eighth was their dog.” Say, “My Lord knows best their number; none know them save a few.” So dispute not concerning them, save with clear argument, nor consult any of them about them. [23] And say not of anything, “Surely I shall do it tomorrow.” [24] Save that God wills. And remember thy Lord when thou dost forget, and say, “It may be that my Lord will guide me nearer than this to rectitude.” [25] And they tarried in their Cave three hundred years, plus nine more. [26] Say: “God knows best how long they tarried. Unto Him belongs the Unseen of the heavens and the earth. How well He sees, how well He hears! They have no protector apart from Him, and He makes no one a partner unto Him in His judgment.” [27] Recite that which has been revealed unto thee from the Book of thy Lord. None alters His Words. And thou wilt find no refuge apart from Him⁸⁵.

There are several studies offering a comparative theological examination of the Christian-Muslim themes inherent to the legend of the Seven Sleepers and the story of the Companions of the Cave⁸⁶.

⁸⁵ Seyyed Hossein Nasr, ed., *The Study Quran: A New Translation and Commentary*, First edition (New York, NY: Harper One, an imprint of Collins Publishers, 2015).

⁸⁶ Some of these works are mentioned here: Christian Krokus, “The Darkness Is Not Death: Toward A Christian-Muslim Comparative Theological Study of the Seven Sleepers of Ephesus,” *Spiritus: A Journal of Christian Spirituality* 17, no. 1 (2017): 40–59.

But what is exclusively of relevance here is how the Qur’anic rendition, because of its ambiguity and elimination of historical context, relates to the notions of darkness and the unseen. These qualities are specifically rooted in the space of the cave and the behavior of the Companions. Below, these relationships are organized and juxtaposed with the famous proverb in ways that together detail their joint contributions to the Path of Nightrise and its station under the mountain of Taibeh. There are four parts to this study, each of which contribute to the station differently:

The Ambiguity of the Qur’anic Rendition

Not only does *Sūrat al-Kahf* abridge the legend of the Seven Sleepers of Ephesus, it also generalizes it by removing any details that might suggest a particular place or time. But the most notable omission is that of the number of Sleepers. This particular omission, unlike all others, is addressed by the Qur’an: “[22] They say: ‘[They were] three, and the fourth was their dog’ – guessing at the unseen. And they say, ‘Seven, and the eighth was their dog.’ Say, ‘My Lord knows best their number; none know them save a few.’ So dispute not concerning them, save with clear argument, nor consult any of them about them.”

By recognizing the debate over the number of Companions, but without specifying their number, the Qur’an is emphasizing the futility of the search for the one correct answer. What is at stake here is far greater than the accuracy of the account. In transcending the binary of the correct and the incorrect, of the accurate and the inaccurate, the Qur’an is recalling the relationship between human consciousness and the unseen. It intervenes on the legend of the Seven Sleepers in the same way that it expects its readers to believe in God: not in succumbing to the material search for the truth, to which only a few have access, but in having faith in its existence, even if ordinary human knowledge cannot confirm it. It is precisely this confidence in the unseen that is echoed by the proverb of Jabal ‘Amil. Its ambiguity, not unlike that of *Sūrat al-Kahf*, should not be read as a provocation to seek more information, but as an invitation to trust the unknown. In other words, the proverb is not challenging its readers to inspect every stone in Jabal ‘Amil (and to prove there to be a poet under each one), but to have confidence that each stone hides a poet regardless. And this is perhaps the most important nuance of all when considering the Path of Nightrise. The station beneath the mountain of Taibeh is but a single iteration of this message of faith, a tribute to it. Searching for the poet is also a practice in trust.

This embrace of the ambiguous is reflected in this station's anatomy, where tension among its seven different components echoes the story of the Companions of the Cave⁸⁷. Designed to make use of the liminal space between them, these individual components together obfuscate any distinction between space and transition. In other words, it is impossible to distinguish the extent of any single distinct component, whether one knows them to be seven or not. As the Qur'an reminds us, one must relinquish the desire to seek the correct number.

The Space of the Cave

The seventeenth verse of *Sūrat al-Kahf* traces the movement of the sun around the cave. As it rises in the east, the sun brushes against the cave's left side. And as it sets in the west, the sun disappears into its right side. The most probable explanation is that the cave faces north. This has been agreed upon by many authors of *tafsir*, or exegesis, who place the cave in the northern hemisphere⁸⁸. In discussing the orientation of the cave, Christian S. Krokus writes, "The ninth-century Qur'an commenter Tabari suggests that the cave opened to the north in order both to protect the Companions' bodies from the heat of the sun and to expose them to a cool wind, thus protecting them from corruption [...]. It also transforms the cave, as Massignon observed, into a sort of mosque, with the qibla on the southern wall in the direction of Jerusalem, Medina, and Mecca."

While the legend of the Seven Sleepers asserts that the cave was sealed with large stones, the movement of the sun in *Sūrat al-kahf* suggests that it was, in fact, unbarred. This is confirmed in the eighteenth verse, "Hadst thou come upon them, thou wouldst have turned away in flight and been filled with terror on their account," which validates the openness of the cave by describing the terror of seeing the Companions, who are asleep but also appear to be awake: "Thou wouldst have thought them awake, though they were asleep." As a mediator between the unseen and the fearful gaze of the onlooker, the Companions' cave resonates with the nature of the space under the stones of Jabal 'Amil (the space between the poet and whoever decides to 'look under'). It also echoes, as George Archer suggests, the liminal space between the living and the underworld, a prominent motif in Middle Eastern mythology. He writes:

⁸⁷ While the Qur'an does not specify the number of Companions, the number '7' is inherently associated with *Ashab al-kahf*. At least this is the case in the village. This can be attributed to many factors, namely, the religious significance of the number seven in Islam (directly linked to the power of the divine), the clear associations between the story of *Ashab al-kahf* and the legend of the Seven Sleepers and, as we will see in the following pages, the relationship between the Companions and the seven stars of the Big Dipper.

⁸⁸ George Archer, "The Hellhound of the Qur'an: A Dog at the Gate of the Underworld," *Journal of Qur'anic Studies* 18, no. 3 (2016): 1–33. 26

It was easy to explain this cosmology by having the sun enter and leave the underworld through a cave or gateway equated with the horizon, the mountains, or both. Compare this to the descents of Middle Eastern solar deities into the land of the dead, such as Gilgamesh, Shamash, or Ishtar. In the Egyptian afterlife dramas, Anubis escorts the dead into the underworld via the solar barge. When Demeter is looking for her lost daughter, Helios points her to a cave that leads down into Hades. [...] The Qur'an is working with a similar motif in a monotheistic form. A cave is a passage to the space under the earth, and the only created being that regularly moves under the earth is the sun.⁸⁹

It is precisely this liminality between the anxious outsider and the underworld, between the seen and the unseen, between the seeker and the poet, that sees to the creation of a station that is not so much a destination, as it is a passage. In this way, the station becomes a detour on the Path of Nightrise, one that does not connect the mountain to the river, but that carries the seeker onwards, in the direction of a poet. And in perpetuating the themes of *Sūrat al-Kahf*, this detour deviates from the path to follow a north-south axis that positions the station towards the seen on the north and the unseen on the south. Not only does this directionality resonate with Tabari's interpretation, it also contributes to it a nocturnal dimension. In the previous stations, the northern winds of the night animated Umm Kamil and called forth the presence of Jabal Qaf. In this case, and owing to the station's openness to the north, they ventilate the space every single night. In other words, only at night do the winds cleanse and purify the space under the mountain of Taibeh. In so doing, they make the search for a poet physically bearable. This not only produces a rift between the hygienic and the optical (the foundation on which the visibility of civilization rests) but foregrounds the tension between the body and the mind that is at the heart of the Path of Nightrise: the comfort of the body being constantly at odds with the comfort of the mind.

The Companions

The petrifying nature of the Companions is not only attributed to their apparent wakefulness. The eighteenth surah reveals another supernatural phenomenon, the turning or rocking of the

⁸⁹ Ibid., 10

Companions: “And We turned them to the right and to the left, with their dog stretching forth his paws at the threshold.” In referencing François Jourdan’s *La tradition des Sept Dormants*, Krokus writes:

There are two main emphases in this theme. The first concerns, once again, the incorruptibility of the Sleepers. Tabari suggests that God sent an angel in nurse-like fashion to prevent the accumulation of bedsores. Traditionally the rocking has been linked to the recitation of the *shabada* in which the believer recites the negation, ‘There is no God,’ to the right and the affirmation, ‘except God,’ to the left. Spiritually for the Muslims, including al-Hallaj (9th-10th c.) and others, ‘this turning is really the sign of total abandonment (*tawakkul*) to God and to his will, as with a ship set upon the sea (Qur’an 18:60, 71, 79).’⁹⁰

There are, of course, other interpretations, but the one I am particularly interested in was offered to me by a farmer, the very same one that had chased me in the night and first prompted this entire project.⁹¹ His version associates the movement of the Companions with that of the seven stars of the Big Dipper, the constellation of Ursa Major, or the Great Bear⁹². He suggests that the movement of the Companions is each synched to a star in the constellation, a relationship that has actually featured in many *tafsir*, and is legendary in various parts of the world. In *The Seven Sleepers and Ancient Constellation Tradition*, Craig Crossen and Stephan Procházka write:

What also makes the following text extremely interesting is that the Seven Brothers refused to join the people waiting for them outside the cave and that, after imploring their Lord, they were taken up to the sky to become the seven bright stars of the constellation of the Great Bear. It is a common belief among the Alawis of Cilicia that the Seven Brothers come down from the sky every night to visit the place where they had been sleeping. Hence there are numerous reports

⁹⁰ Krokus, “The Darkness Is Not Death: Toward A Christian-Muslim Comparative Theological Study of the Seven Sleepers of Ephesus.” 49

⁹¹ I met with him again when I returned to the village in March.

⁹² The stars comprising Ursa Major derive from Arabic and are known as follows: Alkaid, Mizar, Alioth, Megrez, Phecda, Merak, and Dubhe.

of people having seen a light emanating from the Great Bear to the Seven Sleepers shrine near Tarsus.⁹³

The movement of the sun and stars in relation to the Companions and the cave ultimately allude to an everlasting link between the cave and the sky, between the unseen and the cosmos— a theme very much at the heart of the Path of Nightrise and the stations that comprise it. This interaction between macro and microcosm, Amira El-Zein reminds us, is addressed by many medieval Muslim scholars who together reject the Cartesian distinction between soul versus body⁹⁴. Instead, they argue that both the cosmos and the human being are composed of the same tripartite hierarchical structure of spirit, soul, and body, and that the composition of one mirrors the composition of the other⁹⁵. These correlations, she says, “entail that the cosmos and the human are inseparable, and that the outside world is also the inside world.”⁹⁶

And it is this eternal bond between the macrocosm and the microcosm, and particularly between the Companions and the seven bright stars of Ursa Major, that is embodied by the station under the mountain. Each of the seven ovoid bodies immersed in its darkness manifests the motion of a single star from the Big Dipper. The northernmost body, for example, is positioned between the outer world and the dark space under the mountain to follow the motion of Alkaid; its curvature is based on the movement of Alkaid in a single day as seen from Taibeh. The body immediately after it follows the motion of Mizar, and so on, until Dubhe, the final star of the dipper, represented by the southernmost ovoid [Drawings 6.1 and 6.2]. These seven bodies are, again, pushed into the depth of the mountain and submerged in darkness, recalling again the story of the painter Tafas [Drawings 6.3 and 6.4].

While Tafas offers his spectators a small text to help conjure a mental image of his intricate paintings, the station under the mountain draws on other mediums for reference: motion and sound. In fact, its ovoid bodies are not static, but hinged in their lower halves to revolve, collide, and tremble at the slightest movement. It is this slight swinging and colliding that echoes the fear and loss of balance caused by looking at the rocking Companions. But the movement of the seven ovoid bodies is not merely theatrical, it transforms the space via the weight and speed of the seekers. And each time the

⁹³ Craig Crossen and Stephan Procházka, “The Seven Sleepers and Ancient Constellation Traditions — a Crossover of Arabic Dialectology with the History of Astronomy,” *Wiener Zeitschrift Für Die Kunde Des Morgenlandes* 97 (2007): 79–105. 82

⁹⁴ El-Zein, *Islam, Arabs, and the Intelligent World of the Jinn*. 10

⁹⁵ *Ibid.*, 10

⁹⁶ *Ibid.*, 11

bodies shift, the transitions between them either expand or contract. This suggests that the station not only obscures the intricacy and organization of its inner spaces, it also consistently reshapes and reconfigures the journey of the seeker. This kinetic activity creates countless paths to the poet under the mountain of Taibeh.

The Long Night

In the nineteenth verse of *Sūrat al-kahf*, we learn that the Companions believe they have only slept for one night (or less): “And in this way We raised them up again, that they might question one another. One of them said, ‘How long have you tarried?’ They said, ‘We have tarried a day or part of a day.’” And in the twenty-fifth verse we discover that they have actually slept for three hundred and nine years: “And they tarried in their Cave three hundred years, plus nine more.” This tension between the Companions’ temporal consciousness and their 309-year slumber recalls the distortion of time essential to the story of the Three Villagers. It speaks to the power of darkness and the night in producing a rift between human awareness and the logic of the outer diurnal world. And while darkness is often equated with irrationality, inferior to the rationality of sight, these stories inverse that relationship. The Companions and the Villagers, after venturing into the cave and *Tarik al-Nabr* respectively, are introduced to a new temporal logic other to that which they are accustomed to. In contrast with the diurnal realm, time in the Companions’ cave (or perhaps in the darkness of their imagination) is much slower than it is in the outer world. And for the Three Villagers, time on *Tarik al-Nabr* passed much more quickly. What might reading the proverb of Jabal ‘Amil through this nocturnal temporal logic suggest? How does it transform in our imagination once we relinquish the diurnal rationality of sight?

Besides asking us to trust the unseen, the ambiguity of the proverb also draws on our natural attitudes toward light and darkness. And as ambiguity often does, it pushes us to rely on and cling to the familiar when attempting to make sense of strange new situations. Most reading the proverb for the first time would understand “look under” to mean a gaze from the illuminated outer world directed to the underside of the stone. It also follows that one would understand the proverb in relation to a certain scale, a preconceived stone that might range from pebble to boulder in size. This understanding of the proverb embodies a diurnal logic of the world that is attempting to make sense of a space under a

stone in Jabal ‘Amil. This is specifically the kind of ingrained ‘logic’ that the story of the Companions of the cave completely distorts⁹⁷.

If our initial encounter with the proverb directs our gaze from the seemingly limitless, lively, and layered diurnal realm to the finite patch of darkness under a little stone, then the station under the mountain, in keeping with the essence of *Sūrat al-Kahf*, inverts this relationship. Here, it is this finite patch of darkness that transforms to become limitless and layered, and in so doing, dictates a logic that is specific to it. From north to south, from the valley to the underworld, the seven ovoid bodies invite the seeker to be devoured by the mountain. The beginning of this ingestion marks the initiation of a new ritual: a ceremony of self-inflicted blindness, of the violent gouging of the eyes, honoring the beginning of a journey towards the poet. And the fact that this ceremonial journey unfolds between Alkaid (to the north, opening to the valley) and Dubhe (to the south, opening to the underworld) is no mere accident. In Arabian mythology, the Big Dipper was envisaged as a funeral procession around a bier or coffin, represented by the stars outlining the bowl of the dipper (Megrez, Phecda, Merak, and Dubhe). The coffin was followed by the three mourners: Alioth, Mizar, and Alkaid, *Banat al-Na’ash*, or the daughters of al-Na’ash. Their father was murdered by al-Jadi, the polestar Polaris. Every night, they circle around Polaris in their thirst for vengeance, with Mizar holding in her arms her newborn infant Alcor⁹⁸. As such, the death of vision under the mountain of Taibeh echoes cosmically the funeral procession of al-Na’ash, with both ceremonies unfolding from Alkaid to Dubhe and joined only by their allusions to the Companions of the cave.

But how exactly does the ritual under the mountain unfold? In pondering this nocturnal journey to the inner cosmos, there is perhaps no greater inspiration than the *Amduat*, the *Book of What is in the Underworld*, which describes, at each hour of the night, the travels of the sun god Re to the Netherworld. Stuart Tyson Smith summarizes this voyage as follows:

The first three hours describe the denizens of the Underworld and the Waters of Wernes and Osiris, a realm of plenty where the dead live. In the fourth hour, Re enters into the dark and forbidding realm of Ro-Setau, where the falcon-headed god Sokar rules, a desert teeming with snakes that have legs and wings. With the

⁹⁷ The story of the Companions is at complete odds with the story of Plato’s cave, which he uses as an allegory by framing the search for truth as a release from the bondages of darkness and a journey toward light. It is essentially a tribute to the rationality of sight.

⁹⁸ This legend is known as the Funeral of al-Na’ash.

help of towing bargemen, the Sun Bark makes a difficult passage through a zigzag channel and past a lake of fire where the wicked are punished. Re continues through Sokar's realm in the fifth hour, passing by the tomb of Osiris and a group of menacing demons. Then the bark arrives at the Cave of Sokar where the mysterious union between Osiris and Re takes place. In the sixth hour, the Sun Bark leaves Ro-Setau and reaches the deepest part of the Underworld, where the primordial, regenerative waters of Nun allow Re to reunite with his body and the sun to shine again. The seventh hour marks the beginning of the sun god's struggle to reach the eastern horizon, battling past the evil snake god Apophis and his minions. Helpful deities, who restrain Apophis and destroy the enemies of Ma'at, protect Re. From now on a divine bodyguard protects the sun god. Re's travels through the eighth and ninth hours deal with the provisioning of the dead with clothing and food. Using the regenerating waters of Nun in the tenth hour, Re as Horus of the Netherworld revives the drowned, whose souls were in jeopardy because their bodies did not survive to be mummified. Re's enemies are again defeated in the eleventh hour, to be destroyed by the Serpent Who Burns Millions and then be cast into fiery pits. Apophis makes a final attempt to sink the Sun Bark in the twelfth hour, but a group of fearsome goddesses with fire-spitting serpents repel him. Rejoicing deities welcome the rebirth of both Re and Osiris. The sun god flies out of the Underworld as the scarab god Khepri, but Osiris remains as ruler of the Netherworld. With the new dawn comes the renewal of the world as the sky god Shu reseals the eastern entrance to the Underworld.⁹⁹

In the same way that the *Amduat* uses the twelve hours of the night to follow the sun god's rebirth as he battles his way through the underworld, the station under the mountain uses its seven bodies to both forge and narrate the ritual of blindness and the struggles associated with it [Drawing 6.5]. In other words, while the *Amduat* is a descriptive funerary text that recounts the story of Re's confrontations with the world around him, the station is both the description and the inner realm. It not only follows the seeker's inner battles as they travel towards the poet (the gradual turn inwards) but forges these battles itself. The space under the mountain, then, transforms into a spatial *Amduat*

⁹⁹ Stuart Tyson Smith, "The Chamber of Secrets, Grottoes, Caves, and the Underworld in Ancient Egyptian Religion," in *Sacred Darkness*, ed. Holly Moyes (Boulder: University Press of Colorado, 2014). 113

that leverages the story of the Companions and the proverb of Jabal ‘Amil to initiate, on the Path of Nightrise, a ritual of blindness that launches the journey towards the poet [Drawing 6.6]. And there is no better way to describe this ritual than to narrate the story of a seeker as they relinquish the comfort of the valley and surrender to the unseen.

Chapter 1

As the seeker follows the Path of Nightrise out of the valley, they happen upon a space of monumental proportions. “Look under any stone in Jabal ‘Amil and you will find a poet,” recites the seeker, the words carved in sweeping strokes into the gates around them. They stare into the darkness beyond the entrance. Such is the liminal space between the outer cosmos, the seeker’s home, and the subterranean realm where the poet awaits. “Give me your choice,” whispers Alkaid from within.

Chapter 2

As they move from the gate into the unseen, Alkaid shifts, carrying the seeker to Mizar. With a rumbling boom, the two bodies collide and begin the ritual of blindness, the opening of the passage to the poet. “Give me your sight,” requests Mizar, as the seeker moves to climb out of sight. They gradually submerge themselves into darkness and the gate to the valley slowly disappears behind them.

Chapter 3

Now blind, the seeker is carried by Mizar towards Alioth. The next collision initiates a descent. “Give me your place,” instructs Alioth, and the seeker further relinquishes any lingering sense of direction. Alioth knows that blindness alone cannot subdue the seeker’s instinct to return the way they came. Invited down a narrow staircase, the seeker, now completely disoriented, cannot but journey onwards, further into darkness.

Chapter 4

Alioth swings the seeker forward, towards Megrez. Here, the collision instigates yet another descent, one that leads them into an enclosed chamber populated with doorways but with no way out. “Give me your word,” commands Megrez. It is here that the seeker is compelled to speak. Their words echo into the distance and finally reveal a new passage.

Chapter 5

Blinded, disoriented, and made to plead with the darkness, the seeker is carried by Megrez to Phecda. “Give me your friends,” orders Phecda, stirred awake by the gentle collision. The seeker must surrender any company they have journeyed with thus far, for the journey onwards must be completed in solitude. Phecda offers the seeker’s companions refuge until they are able to continue on in turn.

Chapter 6

Gallery full of seekers, Phecda sways forward and allows the first to pass. “Give me your pride,” demands Merak, and the seeker is made to kneel in anticipation of what is to come.

Chapter 7

Merak carries the now humble seeker to Dubhe, where they must slide into the underworld. “Give me your body,” roars Dubhe, commanding the seeker to plunge, head first, into the depths of the unseen below them. As they dive, Dubhe swings forcefully and frees the seeker of their own weight. Swaying weightlessly in the darkness, it is the seeker’s head that hinders them from journeying any further. They must instead surrender their body to Dubhe without knowing how much more of their journey remains. Dubhe sways the seeker as did the angel for the Companions. The remainder of the journey to the poet must be made from within. It is different for every seeker, but so too, in the end, is the poet.



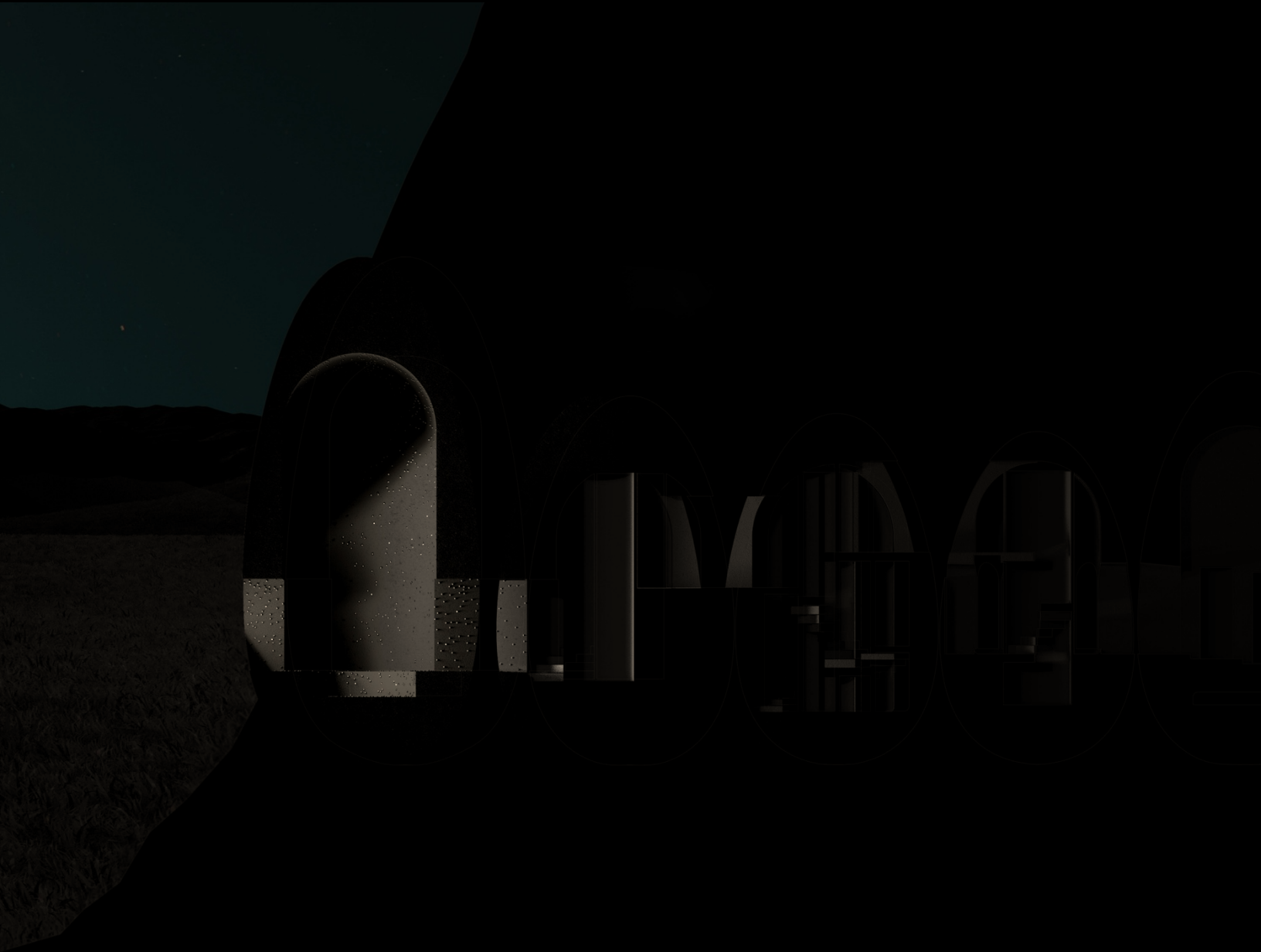

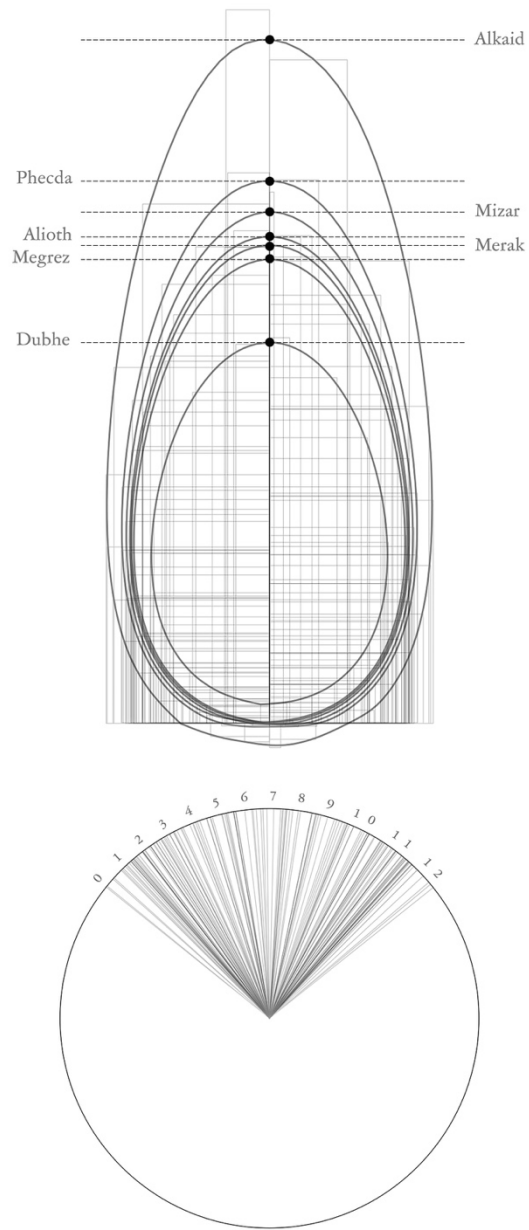

Drawing 6.1 The stars of the Big Dipper as seen from the village of Taibeh.

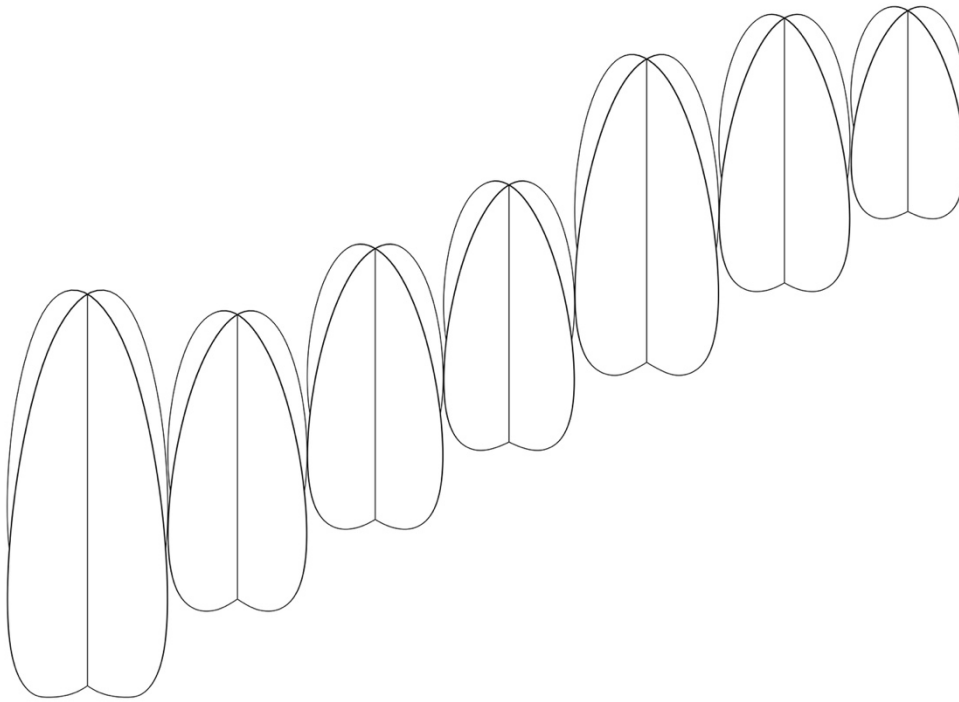

Drawing 6.2 The stars of the Big Dipper and the construction of the narrative.

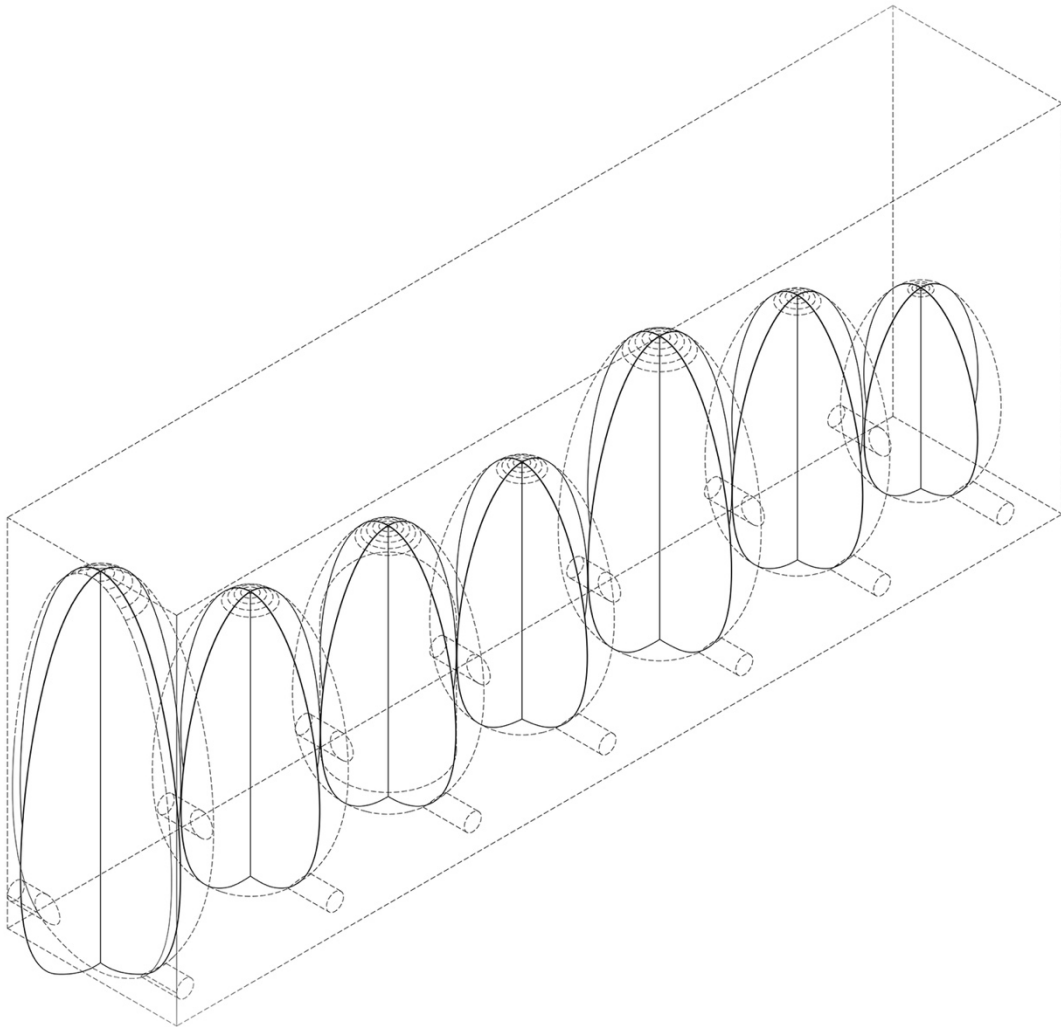

Drawing 6.3 Occupying the space of the cave.

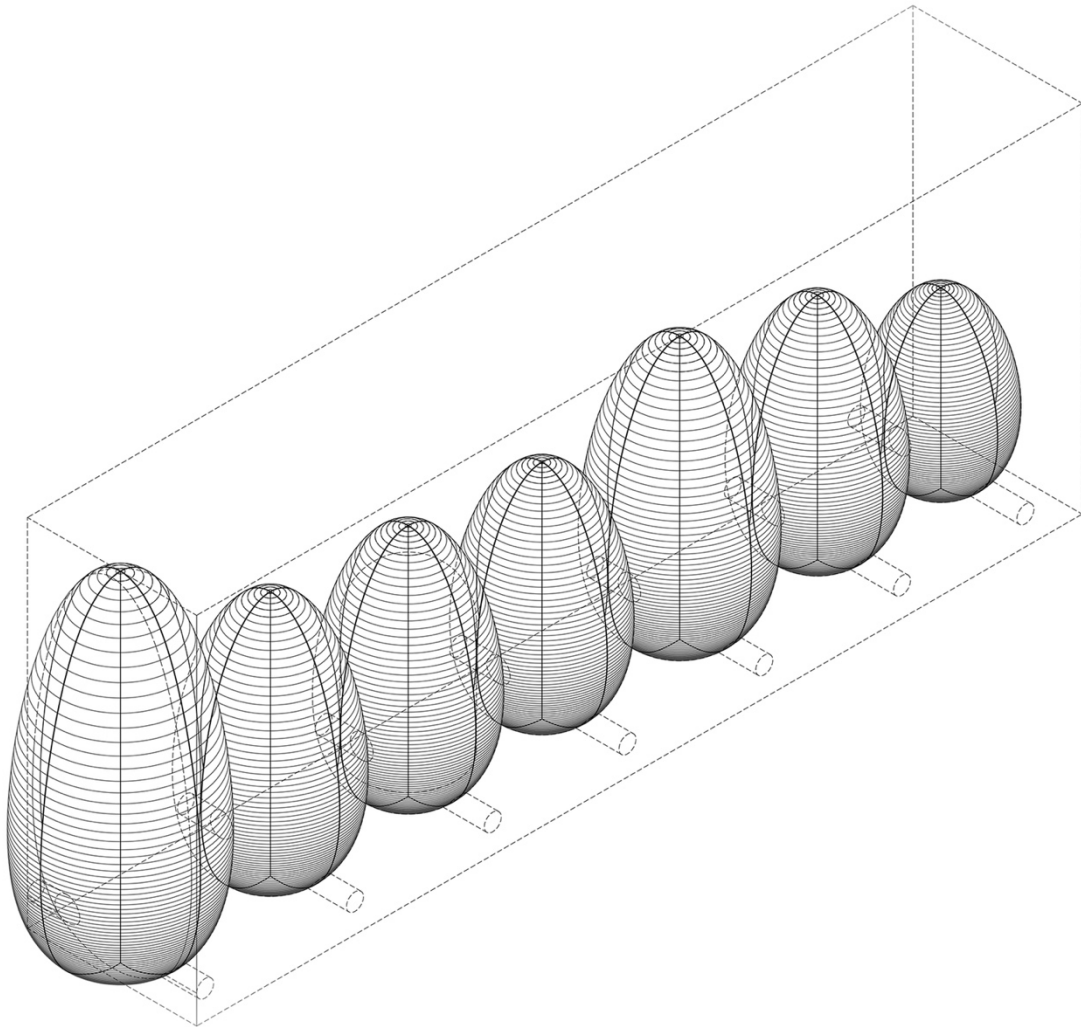

Drawing 6.4 The hinges allow the bodies to shift and collapse.

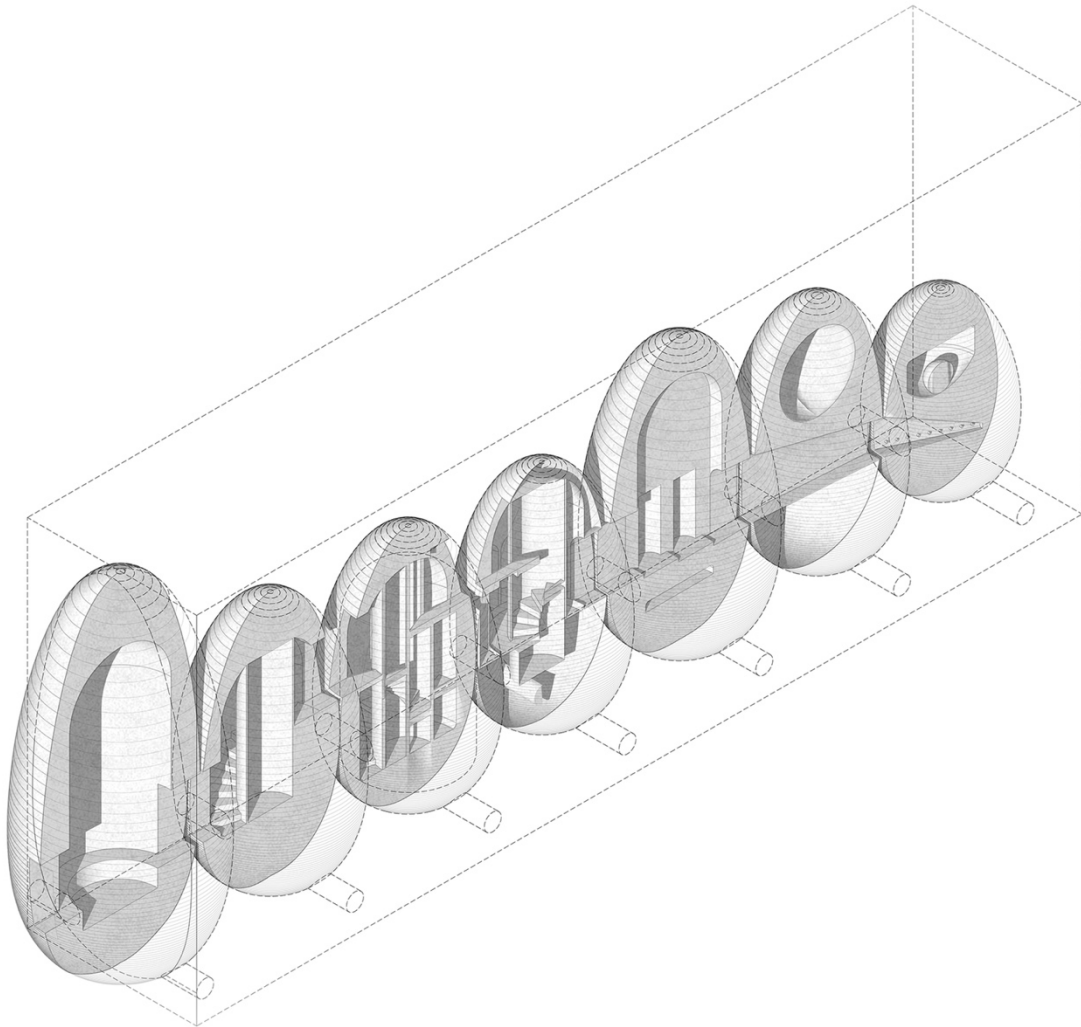

Drawing 6.5 The ritual of blindness.

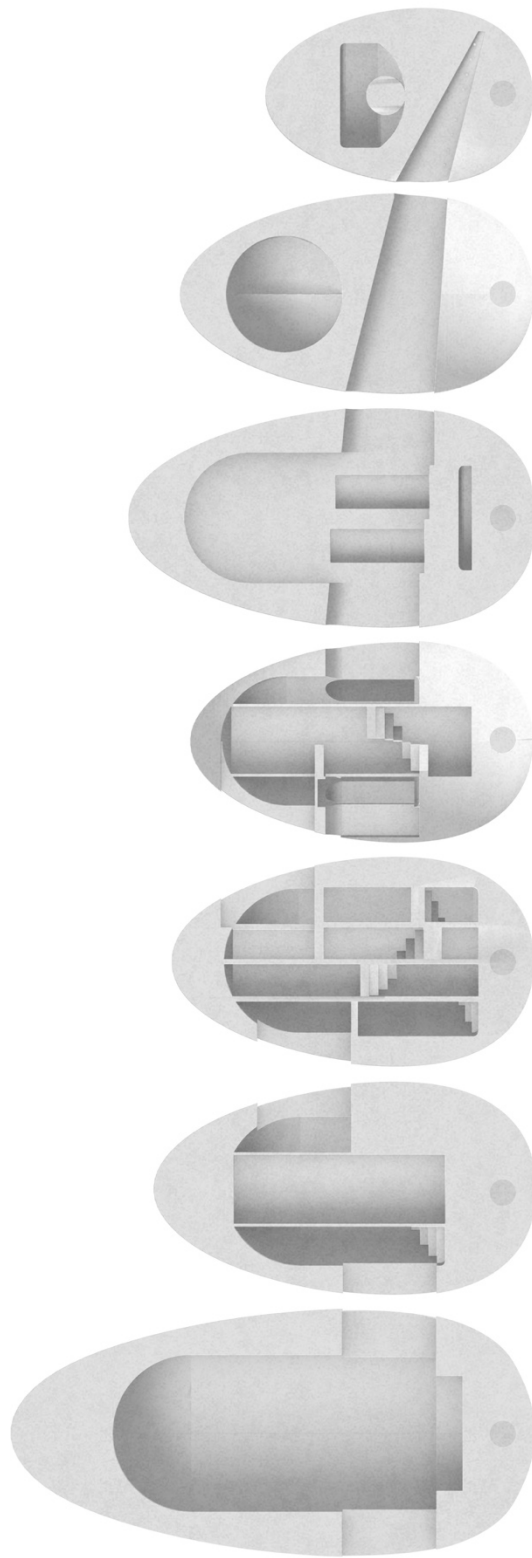

These are only four among countless possible stations. The work to pay tribute to Taibeh's oral legacy along the Path of Nightrise continues on after this thesis.

4. SELECTED BIBLIOGRAPHY

- Abisaab, Rula. "Jabal Amel." In *Encyclopaedia Iranica*, XIV:305–9, n.d.
- Adnan, Etel. *Night*, 2016.
- Amato, Joseph Anthony. *On Foot: A History of Walking*. New York: New York University Press, 2004.
- Archer, George. "The Hellhound of the Qur'an: A Dog at the Gate of the Underworld." *Journal of Qur'anic Studies* 18, no. 3 (2016): 1–33.
- Armengaud, Marc, Matthias Armengaud, and Alessandra Cianchetta, eds. *Nightscapes: Paisajes Nocturnos - nocturnal landscapes*. Land & scape series. Barcelona: GG, Gili, 2009.
- Attlee, James. *Nocturne: A Journey in Search of Moonlight*. Chicago ; London: University of Chicago Press, 2011.
- Bachelard, Gaston. *The Flame of a Candle*. The Bachelard Translations. Dallas: Dallas Institute Publications, 1988.
- Beaumont, Matthew, and Will Self. *Nightwalking: A Nocturnal History of London: Chaucer to Dickens*. Paperback edition. London New York: Verso, 2016.
- Bogard, Paul, ed. *Let There Be Night: Testimony on Behalf of the Dark*. Reno: University of Nevada Press, 2008.
- Bogard, Paul, *The End of Night: Searching for Natural Darkness in an Age of Artificial Light*, 2014.
- Borges, Jorge Luis. *In Praise of Darkness*. 1st ed. New York: Dutton, 1974.
- Borges, Jorge Luis, Adolfo Bioy Casares, and H. Bustos Domecq. *Chronicles of Bustos Domecq*. 1st ed. New York: Dutton, 1976.
- Borges, Jorge Luis, and Andrew Hurley. *Collected Fictions*. Penguin Classics Deluxe Edition. New York, NY: Penguin Books, 1998.
- Browne, Simone. *Dark Matters: On the Surveillance of Blackness*. Durham: Duke University Press, 2015.
- Burton, Richard. *The Thousand Nights and One Night*. Vol. 5. New York: Heritage Press, 1934.
- Careri, Francesco. *Walkscapes: Walking as an Aesthetic Practice*. Ames, IA: Culicidae Architectural Press, 2017.
- Chalabi, Tamara. *The Shi'is of Jabal 'Amil and the New Lebanon: Community and Nation Sate, 1918-1943*. 1st ed. New York: Palgrave Macmillan, 2006.

- Corbin, Henry. *Mundus Imaginalis: Or, The Imaginary and the Imaginal*. Ipswich: Golgonooza Press, 1976.
- Crossen, Craig, and Stephan Procházka. “The Seven Sleepers and Ancient Constellation Traditions — a Crossover of Arabic Dialectology with the History of Astronomy.” *Wiener Zeitschrift Für Die Kunde Des Morgenlandes* 97 (2007): 79–105.
- Dickens, Charles. *Night Walks: And Other Essays*, 2020.
- Doerr, Anthony. *Book Club Kit. a Novel*, 2017.
- Edwards, Nina. *Darkness: A Cultural History*. London, UK: Reaktion Books Ltd, 2018.
- Ekirch, A. Roger. *At Day's Close: Night in Times Past*. 1. ed., 1. publ. as a Norton paperback. London: Weidenfeld & Nicolson [u.a.], 2006.
- El-Zein, Amira. *Islam, Arabs, and the Intelligent World of the Jinn*. First paperback edition. Contemporary Issues in the Middle East. Syracuse, NY: Syracuse University Press, 2017.
- Flower, B.O. *Civilization's Inferno; or, Studies in the Social Cellar*. Boston: Arena Publishing Company, 1893.
- Gide, André. *Travels in the Congo*. Ecco Travels. Hopewell, N.J: Ecco Press, 1994.
- Ginzburg, Carlo. *Il formaggio e i vermi: il cosmo di un mugnaio del '500*. Biblioteca Einaudi 71. Torino: Einaudi, 1999.
- Ginzburg, Carlo. *The Night Battles: Witchcraft and Agrarian Cults in the Sixteenth and Seventeenth Centuries*. Johns Hopkins paperback edition. Baltimore: The Johns Hopkins University Press, 2013.
- Gros, Frédéric, and Clifford Harper. *A Philosophy of Walking*. Translated by John Howe. Paperback edition. London New York: Verso, 2015.
- Harrison, Edward. *Darkness at Night: A Riddle of the Universe*. Cambridge, Mass. u.a: Havard Univ. Pr, 1987.
- Hourani, Albert. “From Jabal ’Āmil to Persia.” *Bulletin of the School of Oriental and African Studies, University of London* 49, no. 1 (1986): 133–40.
- Howes, David, and Constance Classen. *Ways of Sensing: Understanding the Senses in Society*. New York: Routledge, 2014.
- Keiller, Patrick. *The View from the Train: Cities and Other Landscapes*. Paperback edition. Film, Architecture. London New York: Verso, 2014.

- Koslofsky, Craig. *Evening's Empire: A History of the Night in Early Modern Europe*. New Studies in European History. Cambridge ; New York: Cambridge University Press, 2011.
- Kreitzman, Leon. *The 24 Hour Society*. London: Profile Books, 1999.
- Krokus, Christian. "The Darkness Is Not Death: Toward A Christian-Muslim Comparative Theological Study of the Seven Sleepers of Ephesus." *Spiritus: A Journal of Christian Spirituality* 17, no. 1 (2017): 40–59.
- Landes, David S. *Revolution in Time: Clocks and the Making of the Modern World*. Rev. and enl. Ed. Cambridge, MA: Harvard University Press, 2000.
- Laporte, Dominique. *History of Shit*. A Documents Book. Cambridge, Mass. London: The MIT Press, 2002.
- Lefebvre, Henri. *Le droit à la ville*. Paris: Economica : Anthropos, 2009.
- Lynch, Kevin. *The Image of the City*. Nachdr. Publication of the Joint Center for Urban Studies. Cambridge, Mass.: MIT PRESS, 2005.
- Mabey, Richard. *The Unofficial Countryside*. Wimborne Minster: Dovecote, 2010.
- Mariani, Manuela, and Patrick Barron, eds. *Terrain Vague: Interstices at the Edge of the Pale*. First edition. New York: Routledge, 2014.
- Marvin, Carolyn. *When Old Technologies Were New: Thinking about Electric Communication in the Late Nineteenth Century*. Nachdr. Ill, 1990.
- Melbin, Murray. *Night as Frontier: Colonizing the World after Dark*. New York : London: Free Press ; Collier Macmillan, 1987.
- Milton, John, and John Leonard. *Paradise Lost*. Penguin Classics. London: Penguin Classics, an imprint of Penguin Books, 2014.
- Moyes, Holley, and Jean Clottes. *Sacred Darkness: A Global Perspective on the Ritual Use of Caves*, 2014.
- Mumford, Lewis. *The City in History: Its Origins, Its Transformations, and Its Prospects*. A Harvest Book. San Diego New York London: Harcourt, Inc, 1989.
- Nasr, Seyyed Hossein, ed. *The Study Quran: A New Translation and Commentary*. First edition. New York, NY: HarperOne, an imprint of Collins Publishers, 2015.
- Nightingale, Andrea. "Cave Myths and the Metaphorics of Light: Plato, Aristotle, Lucretius." *Arion: A Journal of Humanities and the Classics* 24, no. 3 (2017): 39–70.
- Nye, David E. *Electrifying America: Social Meanings of a New Technology, 1880 - 1940*. 6. print. Cambridge, Mass.: MIT Press, 2001.

- Otero Verzier, Marina, and Francien van Westrenen. *I See That I See What You Don't See*, 2020.
- Paez, Roger. *Operative Mapping: The Use of Maps as a Design Tool*. Print edition. New York, NY: Actar Publishers, 2018.
- Pallasmaa, Juhani. *The Eyes of the Skin: Architecture and the Senses*. 3. ed. Chichester: Wiley, 2012.
- Palmer, Bryan D. *Cultures of Darkness: Night Travels in the Histories of Transgression*. New York: Monthly Review Press, 2000.
- Palmer, John D. *The Living Clock: The Orchestrator of Biological Rhythms*. Oxford ; New York: Oxford University Press, 2002.
- Pamuk, Orhan, and Erdağ Gökna. *My Name Is Red*. 1st Vintage International ed. New York: Vintage International, 2002.
- Pastoureau, Michel. *Black: The History of a Color*. English language ed. Princeton, N.J: Princeton University Press, 2009.
- Şādiqī, ‘Alī, and Ḥasan Muḥammad Najafī. *Al-Shahīd al-Thānī Zayn al-Dīn al-Jub‘ī al-‘Amilī*. 2. ed. Meeting the Pious 6. Qum: Ansariyan, 2001.
- Saint-Exupéry, Antoine de, and Richard Howard. *The Little Prince*. 1st ed. San Diego: Harcourt, 2000.
- Schivelbusch, Wolfgang. *Disenchanted Night: The Industrialization of Light in the Nineteenth Century*. Berkeley: Univ. of California Pr, 1995.
- Scott, James C. *Seeing like a State: How Certain Schemes to Improve the Human Condition Have Failed*. Nachdr. Yale Agrarian Studies. New Haven, Conn.: Yale Univ. Press, 2008.
- Shakespeare, William. *Macbeth*. Dover Thrift Editions. New York: Dover Publications, 1993.
- Sharlet, Jeff. *This Brilliant Darkness: A Book of Strangers*. First edition. New York, NY: W. W. Norton & Company, 2020.
- Sophocles, David Grene, and Sophocles. *Oedipus the King*. Chicago ; London: The University of Chicago Press, 2010.
- Suhrawardī, Yaḥyá ibn Ḥabash, and Henry Corbin. *L'archange empourpré: quinze traités et récits mystiques*. Documents spirituels ; 14. Paris: Fayard, 1976.
- Tanizaki, Jun'ichirō. *In Praise of Shadows*. Sedgwick: Leete's Island Books, 2008.
- The Aga Khan Program and The Department of Landscape Architecture, Harvard Graduate School of Design and the CMES Arabian Peninsula Studies. "After Dark:

Nocturnal Landscapes and Public Spaces in the Arabian Peninsula.” CGIS South, Rm 020, 1730 Cambridge St; Piper Auditorium, Grad School of Design 48 Quincy St, Fri - Sat, Apr 7 to Apr 8, 4:00pm - 6:00pm.

Ubelaker Andrade, Max. *Borges beyond the Visible*. University Park, Pennsylvania: Pennsylvania State University Press, 2019.

West, Edward William. *Pahlavi texts*. Place of publication not identified: forgotten books, 2015.

Yates, Frances A. *The Art of Memory*. London: The Bodley Head, 2014.

5. APPENDIX

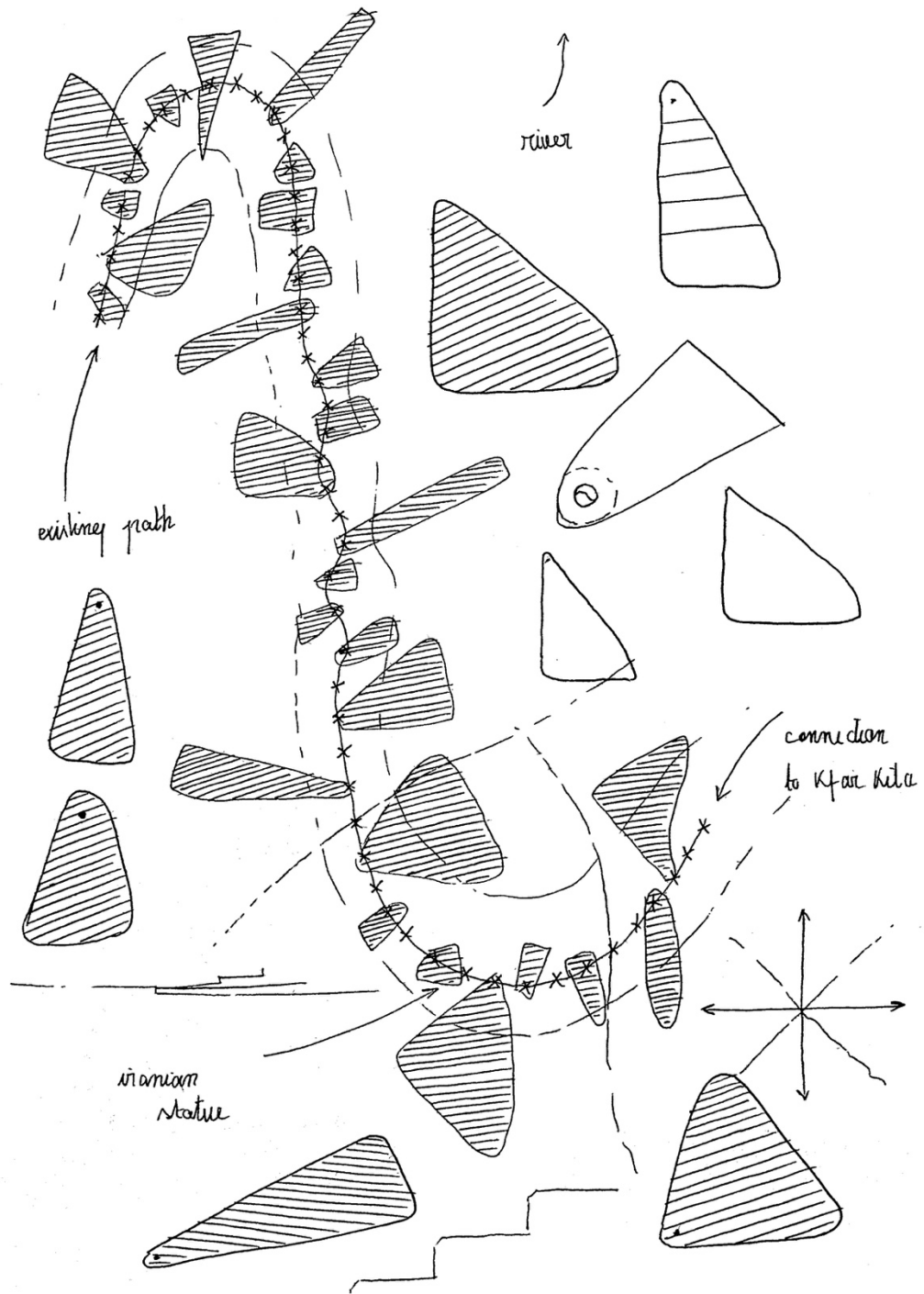

② Al-Shahid al-Thani: Zayn al-Din al-Jubbi al-Amili

Muhammad al-Farqhani's Elements of Chronology and Astronomy

Beginning of Day: Sunset

Beginning of week: Saturday at sunset

Sana Hejriyya-

Geocentric model

Latitude Lebanon: 33.8547

03/09/1506	03/09/1867
03/09/1525	03/09/1886
03/09/1544	03/09/1905
03/09/1563	03/09/1924
03/09/1582	03/09/1943
03/09/1601	03/09/1962
03/09/1620	03/09/1981
03/09/1639	03/09/2000
03/09/1658	03/09/2019
03/09/1677	03/09/2038
03/09/1696	
03/09/1715	
03/09/1734	
03/09/1753	
03/09/1772	188.10° 7
03/09/1791	214.89° 8
03/09/1810	233.91° 9
03/09/1829	247.16° 10
	257.19° 11

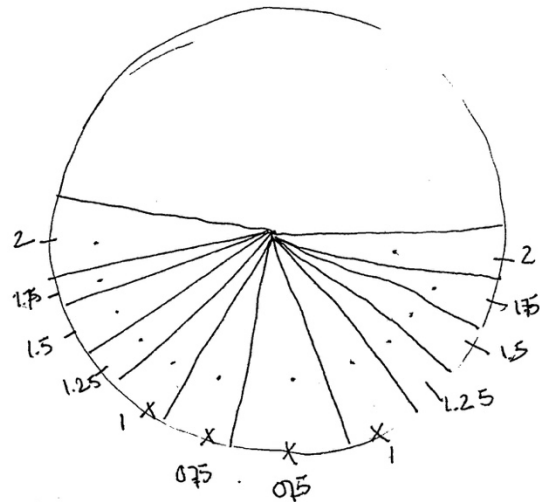

158.35° 6
134.58° 5
118.14° 4
106.29° 3
96.87° 2

the simplicity of a column
the complexity of a column
a column here, but casting shadow in jabal Qaf

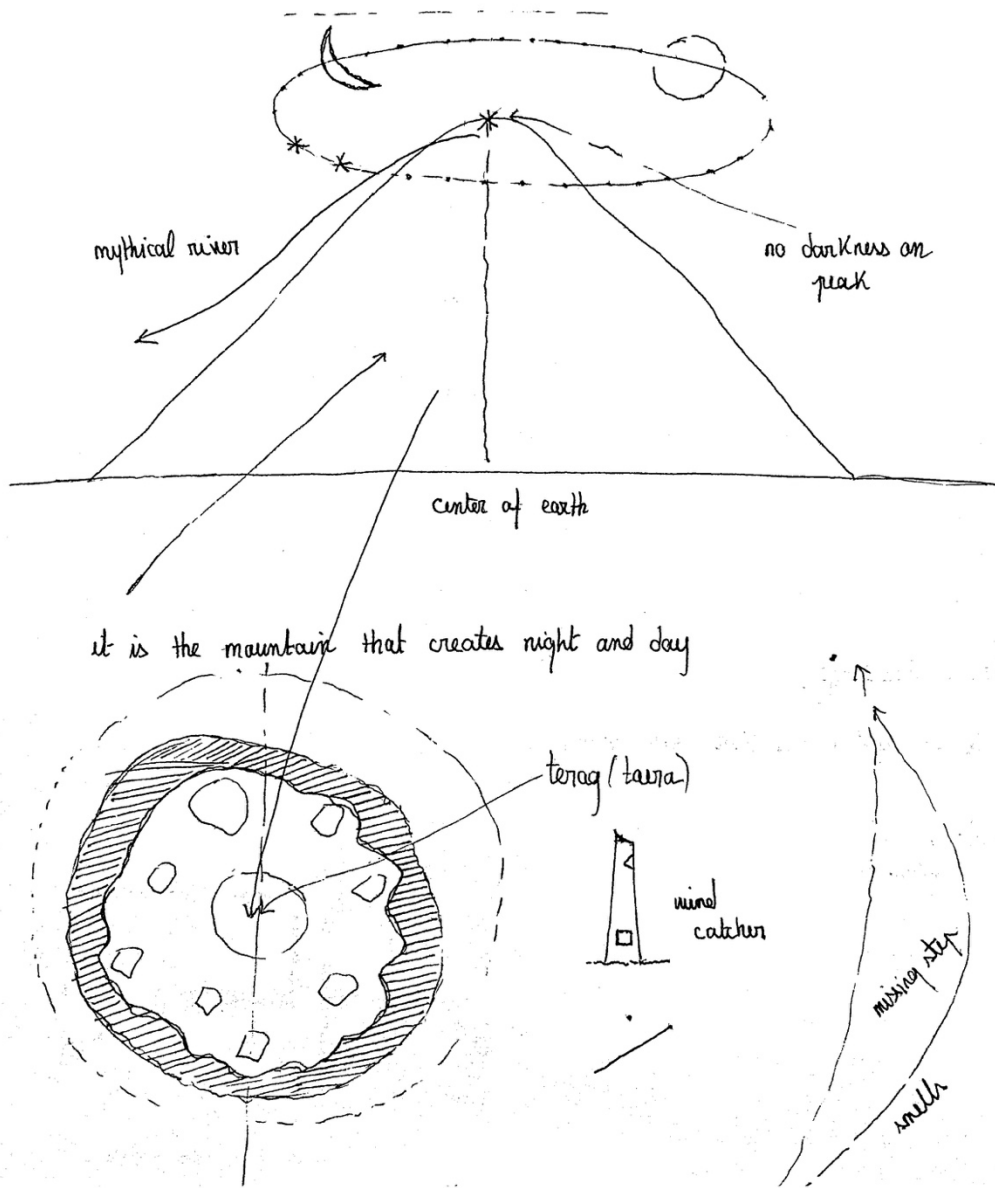

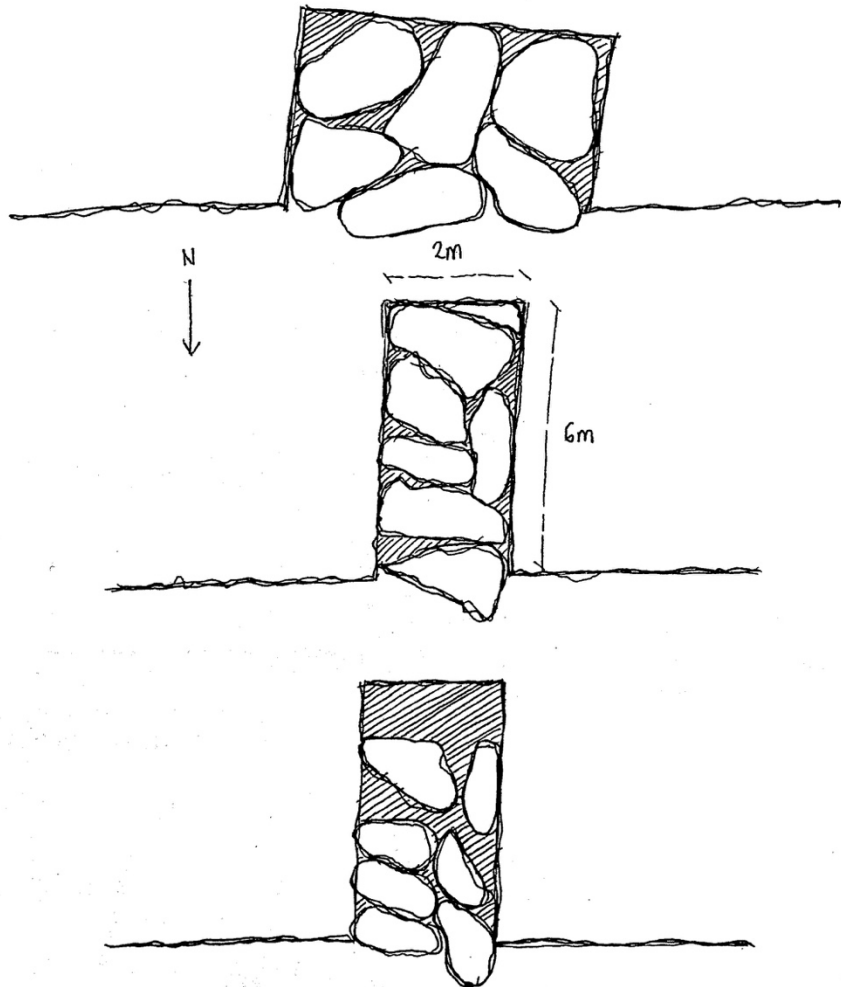

① Alkaid

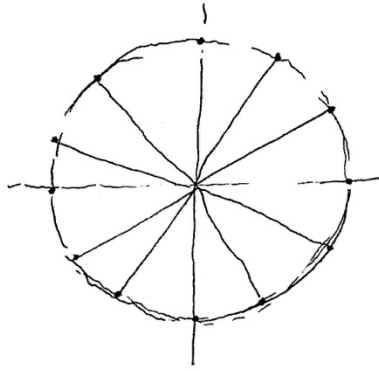

23.9345

23 hours, 56 minutes, 4 seconds

0.99727 0.8362

59 minutes, 50 seconds

$$19 \begin{cases} 6.812 \\ -5.007 \end{cases}$$

$$22 \begin{cases} 32.787 \\ 6.094 \end{cases}$$

$$20 \begin{cases} 16.339 \\ -3.538 \end{cases}$$

$$23 \begin{cases} 39.313 \\ 13.507 \end{cases}$$

$$21 \begin{cases} 25.087 \\ 0.003 \end{cases}$$

$$24 \begin{cases} 44.603 \\ 21.928 \end{cases}$$

$$\left. \begin{array}{l} 12.59.50 \begin{cases} az: 48.51 \\ alt: 30.892 \end{cases} \\ 13.59.40 \begin{cases} az: 50.931 \\ alt: 40.478 \end{cases} \end{array} \right\}$$

$$12 \begin{cases} 44.296 \\ 21.351 \end{cases}$$

$$9 \begin{cases} 310.474 \\ 56.515 \end{cases}$$

$$14 \begin{cases} 323.027 \\ 10.552 \end{cases}$$

$$1 \begin{cases} 48.351 \\ 30.461 \end{cases}$$

$$10 \begin{cases} 308.601 \\ 46.772 \end{cases}$$

$$15 \begin{cases} 330.009 \\ 8.601 \end{cases}$$

$$2 \begin{cases} 50.857 \\ 40.057 \end{cases}$$

$$11 \begin{cases} 309.74 \\ 36.998 \end{cases}$$

$$16 \begin{cases} 338.129 \\ -0.09 \end{cases}$$

$$3 \begin{cases} 51.218 \\ 49.864 \end{cases}$$

$$5 \begin{cases} 37.266 \\ 68.014 \end{cases}$$

$$7 \begin{cases} 338.141 \\ 72.461 \end{cases}$$

$$12 \begin{cases} 312.774 \\ 27.527 \end{cases}$$

$$17 \begin{cases} 347.213 \\ -4.334 \end{cases}$$

$$4 \begin{cases} 47.944 \\ 59.493 \end{cases}$$

$$6 \begin{cases} 12.009 \\ 73.622 \end{cases}$$

$$8 \begin{cases} 318.178 \\ 65.607 \end{cases}$$

$$13 \begin{cases} 317.26 \\ 18.624 \end{cases}$$

$$18 \begin{cases} 356.932 \\ -6.595 \end{cases}$$

② Mizar

12 $\left\{ \begin{array}{l} 40.257 \\ 26.92 \end{array} \right.$	7 $\left\{ \begin{array}{l} 337.521 \\ 65.789 \end{array} \right.$	14 $\left\{ \begin{array}{l} 329.757 \\ 11.529 \end{array} \right.$	21 $\left\{ \begin{array}{l} 24.827 \\ 6.668 \end{array} \right.$
1 $\left\{ \begin{array}{l} 42.348 \\ 35.282 \end{array} \right.$	8 $\left\{ \begin{array}{l} 324.348 \\ 59.558 \end{array} \right.$	15 $\left\{ \begin{array}{l} 336.329 \\ 5.815 \end{array} \right.$	22 $\left\{ \begin{array}{l} 31.225 \\ 12.59 \end{array} \right.$
2 $\left\{ \begin{array}{l} 43.522 \\ 43.917 \end{array} \right.$	9 $\left\{ \begin{array}{l} 318.229 \\ 51.619 \end{array} \right.$	16 $\left\{ \begin{array}{l} 343.856 \\ 1.522 \end{array} \right.$	23 $\left\{ \begin{array}{l} 36.489 \\ 19.611 \end{array} \right.$
3 $\left\{ \begin{array}{l} 41.392 \\ 52.451 \end{array} \right.$	10 $\left\{ \begin{array}{l} 316.439 \\ 43.054 \end{array} \right.$	17 $\left\{ \begin{array}{l} 352.099 \\ -0.895 \end{array} \right.$	24 $\left\{ \begin{array}{l} \checkmark \end{array} \right.$
4 $\left\{ \begin{array}{l} 34.707 \\ 60.28 \end{array} \right.$	11 $\left\{ \begin{array}{l} 317.334 \\ 34.431 \end{array} \right.$	18 $\left\{ \begin{array}{l} 0.716 \\ -0.105 \end{array} \right.$	
5 $\left\{ \begin{array}{l} 20.682 \\ 66.249 \end{array} \right.$	12 $\left\{ \begin{array}{l} 320.087 \\ 26.113 \end{array} \right.$	19 $\left\{ \begin{array}{l} 9.298 \\ 0.794 \end{array} \right.$	
6 $\left\{ \begin{array}{l} 358.824 \\ 68.462 \end{array} \right.$	13 $\left\{ \begin{array}{l} 324.296 \\ 18.388 \end{array} \right.$	20 $\left\{ \begin{array}{l} 17.444 \\ 2.122 \end{array} \right.$	

③ Alioth

12 $\left\{ \begin{array}{l} 40.582 \\ 31.272 \end{array} \right.$	4 $\left\{ \begin{array}{l} 27.269 \\ 62.831 \end{array} \right.$	8 $\left\{ \begin{array}{l} 322.293 \\ 55.338 \end{array} \right.$	12 $\left\{ \begin{array}{l} 323.004 \\ 22.654 \end{array} \right.$	16 $\left\{ \begin{array}{l} 348.185 \\ 0.98 \end{array} \right.$
1 $\left\{ \begin{array}{l} 42.127 \\ 39.606 \end{array} \right.$	5 $\left\{ \begin{array}{l} 9.827 \\ 66.944 \end{array} \right.$	9 $\left\{ \begin{array}{l} 318.433 \\ 47.26 \end{array} \right.$	13 $\left\{ \begin{array}{l} 327.704 \\ 15.489 \end{array} \right.$	17 $\left\{ \begin{array}{l} 356.443 \\ -0.693 \end{array} \right.$
2 $\left\{ \begin{array}{l} 41.378 \\ 48.016 \end{array} \right.$	6 $\left\{ \begin{array}{l} 348.3 \\ 66.731 \end{array} \right.$	10 $\left\{ \begin{array}{l} 317.931 \\ 38.84 \end{array} \right.$	14 $\left\{ \begin{array}{l} 333.574 \\ 9.309 \end{array} \right.$	18 $\left\{ \begin{array}{l} 4.87 \\ -0.538 \end{array} \right.$

$$20 \begin{cases} 20.197 \\ 4.775 \end{cases}$$

$$21 \begin{cases} 27.004 \\ 9.822 \end{cases}$$

$$22 \begin{cases} 32.774 \\ 16.103 \end{cases}$$

$$23 \begin{cases} 37.359 \\ 23.344 \end{cases}$$

④ Megrez

$$12 \begin{cases} 40.468 \\ 36.701 \end{cases}$$

$$7 \begin{cases} 326.574 \\ 57.468 \end{cases}$$

$$14 \begin{cases} 338.481 \\ 6.884 \end{cases}$$

$$21 \begin{cases} 30.336 \\ 14.82 \end{cases}$$

$$1 \begin{cases} 40.466 \\ 44.894 \end{cases}$$

$$8 \begin{cases} 320.967 \\ 49.968 \end{cases}$$

$$15 \begin{cases} 345.73 \\ 3.01 \end{cases}$$

$$22 \begin{cases} 35.129 \\ 21.635 \end{cases}$$

$$2 \begin{cases} 37.507 \\ 52.856 \end{cases}$$

$$9 \begin{cases} 319.25 \\ 41.861 \end{cases}$$

$$16 \begin{cases} 353.61 \\ 0.748 \end{cases}$$

$$23 \begin{cases} 38.62 \\ 29.2 \end{cases}$$

$$3 \begin{cases} 29.963 \\ 59.919 \end{cases}$$

$$10 \begin{cases} 320.08 \\ 33.694 \end{cases}$$

$$17 \begin{cases} 1.789 \\ 0.242 \end{cases}$$

$$4 \begin{cases} 15.866 \\ 64.922 \end{cases}$$

$$11 \begin{cases} 322.728 \\ 25.828 \end{cases}$$

$$18 \begin{cases} 9.883 \\ 1.525 \end{cases}$$

$$5 \begin{cases} 356.218 \\ 66.29 \end{cases}$$

$$12 \begin{cases} 326.812 \\ 18.557 \end{cases}$$

$$19 \begin{cases} 17.524 \\ 4.512 \end{cases}$$

$$6 \begin{cases} 338.079 \\ 63.409 \end{cases}$$

$$13 \begin{cases} 332.116 \\ 12.152 \end{cases}$$

$$20 \begin{cases} 24.414 \\ 9.024 \end{cases}$$

⑤ Phecda

$$12 \begin{cases} 45.058 \\ 39.437 \end{cases}$$

$$7 \begin{cases} 318.591 \\ 56.239 \end{cases}$$

$$14 \begin{cases} 338.813 \\ 2.725 \end{cases}$$

$$21 \begin{cases} 34.651 \\ 14.736 \end{cases}$$

$$1 \begin{cases} 44.742 \\ 48.348 \end{cases}$$

$$8 \begin{cases} 315.116 \\ 47.584 \end{cases}$$

$$15 \begin{cases} 346.918 \\ -0.99 \end{cases}$$

$$22 \begin{cases} 39.564 \\ 22.338 \end{cases}$$

$$2 \begin{cases} 40.883 \\ 56.952 \end{cases}$$

$$9 \begin{cases} 315.032 \\ 38.67 \end{cases}$$

$$16 \begin{cases} 355.629 \\ -1.097 \end{cases}$$

$$23 \begin{cases} 43.129 \\ 30.664 \end{cases}$$

$$3 \begin{cases} 30.889 \\ 64.43 \end{cases}$$

$$10 \begin{cases} 317.119 \\ 29.924 \end{cases}$$

$$17 \begin{cases} 44.554 \\ -1.117 \end{cases}$$

$$4 \begin{cases} 11.5 \\ 69.124 \end{cases}$$

$$11 \begin{cases} 320.809 \\ 21.651 \end{cases}$$

$$18 \begin{cases} 13.257 \\ -0.931 \end{cases}$$

$$5 \begin{cases} 346.454 \\ 68.889 \end{cases}$$

$$12 \begin{cases} 325.464 \\ 14.589 \end{cases}$$

$$19 \begin{cases} 21.346 \\ 2.819 \end{cases}$$

$$6 \begin{cases} 327.915 \\ 63.864 \end{cases}$$

$$13 \begin{cases} 331.602 \\ 8.011 \end{cases}$$

$$20 \begin{cases} 28.537 \\ 8.134 \end{cases}$$

⑥ Merak

$$12 \begin{cases} 41.044 \\ 46.78 \end{cases}$$

$$7 \begin{cases} 319.367 \\ 48.35 \end{cases}$$

$$14 \begin{cases} 347.199 \\ 1.761 \end{cases}$$

$$21 \begin{cases} 36.643 \\ 22.958 \end{cases}$$

$$1 \begin{cases} 37.331 \\ 54.78 \end{cases}$$

$$8 \begin{cases} 318.404 \\ 40.043 \end{cases}$$

$$15 \begin{cases} 355.312 \\ -0.156 \end{cases}$$

$$22 \begin{cases} 39.914 \\ 30.767 \end{cases}$$

$$2 \begin{cases} 28.445 \\ 61.699 \end{cases}$$

$$9 \begin{cases} 319.783 \\ 31.782 \end{cases}$$

$$16 \begin{cases} 3.646 \\ 0.271 \end{cases}$$

$$23 \begin{cases} 41.534 \\ 38.996 \end{cases}$$

$$3 \begin{cases} 12.358 \\ 66.197 \end{cases}$$

$$10 \begin{cases} 322.868 \\ 23.934 \end{cases}$$

$$17 \begin{cases} 11.808 \\ 1.425 \end{cases}$$

$$4 \begin{cases} 351.466 \\ 66.631 \end{cases}$$

$$11 \begin{cases} 327.328 \\ 16.693 \end{cases}$$

$$18 \begin{cases} 19.433 \\ 4.821 \end{cases}$$

$$5 \begin{cases} 334.038 \\ 62.797 \end{cases}$$

$$12 \begin{cases} 332.977 \\ 10.42 \end{cases}$$

$$19 \begin{cases} 26.238 \\ 9.713 \end{cases}$$

$$6 \begin{cases} 323.893 \\ 56.216 \end{cases}$$

$$13 \begin{cases} 339.664 \\ 5.357 \end{cases}$$

$$20 \begin{cases} 32.025 \\ 15.849 \end{cases}$$

⑦ Dubhe

$$12 \left\{ \begin{array}{l} 33.511 \\ 45.492 \end{array} \right.$$

$$1 \left\{ \begin{array}{l} 29.488 \\ 52.114 \end{array} \right.$$

$$2 \left\{ \begin{array}{l} 21.551 \\ 57.598 \end{array} \right.$$

$$3 \left\{ \begin{array}{l} 9.247 \\ 61.002 \end{array} \right.$$

$$4 \left\{ \begin{array}{l} 354.438 \\ 61.416 \end{array} \right.$$

$$5 \left\{ \begin{array}{l} 341.192 \\ 58.706 \end{array} \right.$$

$$6 \left\{ \begin{array}{l} 332.126 \\ 53.654 \end{array} \right.$$

$$7 \left\{ \begin{array}{l} 327.201 \end{array} \right.$$

$$19 \left\{ \begin{array}{l} 22.388 \\ 13.544 \end{array} \right.$$

$$20 \left\{ \begin{array}{l} 27.352 \\ 18.847 \end{array} \right.$$

$$21 \left\{ \begin{array}{l} 31.208 \\ 25.015 \end{array} \right.$$

$$22 \left\{ \begin{array}{l} 33.74 \\ 31.788 \end{array} \right.$$

$$23 \left\{ \begin{array}{l} 34.624 \\ 38.88 \end{array} \right.$$

$$18 \left\{ \begin{array}{l} 16.509 \\ 9.345 \end{array} \right.$$

$$17 \left\{ \begin{array}{l} 9.926 \\ 6.461 \end{array} \right.$$

$$8 \left\{ \begin{array}{l} 325.47 \\ 40.701 \end{array} \right.$$

$$9 \left\{ \begin{array}{l} 325.862 \\ 33.579 \end{array} \right.$$

$$10 \left\{ \begin{array}{l} 328.009 \\ 26.696 \end{array} \right.$$

$$11 \left\{ \begin{array}{l} 331.551 \\ 20.348 \end{array} \right.$$

$$12 \left\{ \begin{array}{l} 336.25 \\ 14.801 \end{array} \right.$$

$$13 \left\{ \begin{array}{l} 341.915 \\ 10.299 \end{array} \right.$$

$$14 \left\{ \begin{array}{l} 348.341 \\ 7.062 \end{array} \right.$$

$$15 \left\{ \begin{array}{l} 355.28 \\ 5.265 \end{array} \right.$$

$$16 \left\{ \begin{array}{l} 2.433 \\ 5.014 \end{array} \right.$$

