

ADJUNCTIONS AND PROJECTIONS IN SYNTAX

Vol. 1

by

Margaret Jean Spears

B A. Washington University

(1973)

M A University of Arizona

(1981)

Submitted to the Department of Linguistics and Philosophy
in Partial Fulfillment of the Requirements
of the Degree of

DOCTOR OF PHILOSOPHY

at the

MASSACHUSETTS INSTITUTE OF TECHNOLOGY

June 1986

© Margaret J Spears 1986

The author hereby grants to M. I. T. permission to reproduce
and to distribute copies of this thesis document in whole or in part.

Signature of Author

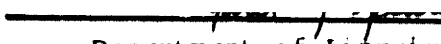
Department of Linguistics and Philosophy
June 27 1986

Certified by

Kenneth Hale, Thesis Supervisor

Accepted by

Wayne O'Neil
Chair, Departmental Committee

MASSACHUSETTS INSTITUTE
OF TECHNOLOGY

JUL 07 1986

LIBRARIES

ARCHIVES

ADJUNCTIONS AND PROJECTIONS IN SYNTAX

by

MARGARET JEAN SPEAS

Submitted to the Department of Linguistics and Philosophy
on June 27, 1986 in partial fulfillment of the
requirements for the Degree of Doctor of Philosophy in
Linguistics

ABSTRACT

This dissertation presents a theory of projection of syntactic configurations from the lexicon. The first chapter outlines a theory of the D-Structure level of representation in which all well-formedness conditions on underlying structures are deducible from other independent principles of the Grammar. This theory extends the work of Stowell, who argued that linear precedence relations could be derived from independent principles. I propose that domination relations may likewise be derived from independent principles. This proposal is based on the theory of lexical representations of Higginbotham (1985, 1986), in which words of all lexical categories (N, V, A, P) are thought to have a 'theta grid' as part of their lexical entry. It is argued that the relations which hold among these grids are sufficient to give all the information that we need to deduce the domination relations which result when these lexical entries are projected from the lexicon. The structures which are so projected, which I call Thematic Structures, are universal abstract relational structures. They encode domination relations, which are derived from thematic relations, but do not encode precedence nor do they encode adjacency. It is further proposed that non-lexical or 'Functional' categories are heads at D-Structure, but that the way that they project differs in significant ways from the way that lexical categories project. The first Chapter concludes with a discussion of the properties of adjunction constructions, pointing out that the claims of May (1985) about domination relations in LF adjunction structures lead to the conclusion that such structures are always three-dimensional.

The second chapter has to do with the two related issues which have come to be associated with the term "Configurationality". The first is the question of whether all languages distinguish structurally between subject and object. The diverse data which have been adduced as evidence for variation in configurationality are brought together in order to clarify the issue. While it is often assumed that "nonconfigurational" languages are those with 'flat' structures, the data actually seem to call for some sort of dual representation.

The second issue is then shown to be related to, but independent of, the issue of underlying domination relations. It is claimed that the proposal of Jelinek (1984) that the Configurationality parameter should be stated in terms of the status of overt nominals as adjuncts and of

pronominal clitics as arguments is on the right track, but it makes the wrong prediction in certain cases, and it could allow violations of the Projection Principle.

The language used as a case study is Navajo. It has been proposed that Navajo overt nominals are actually adjuncts, and that pronominal clitics are the 'real' arguments. There are two problems with this. First, by standard syntactic tests, overt nominals do not behave like adjuncts, they behave like arguments. Second, the pronominal clitics are embedded within an apparently unstructured string of prefixes, and it is not obvious that they are accessible to syntax at all, let alone in argument positions.

Chapter 3 considers in detail the status of the Navajo prefixes which mark subject and object agreement. Arguments are given that these agreement prefixes must be infixes, that is, that they must be inserted into a discontinuous lexical item.

If this infixation model for Navajo is correct, then the problem of the accessibility of the pronominal agreement clitics in the syntax is not so serious; in fact it might be proposed that they are in argument positions at D-Structure and S-Structure, and simply infix at PF. However, such a proposal would contradict the syntactic evidence that overt nominals are in argument, not adjoined, positions. As a solution to this problem, an extension of the definition of an allowable syntactic CHAIN is suggested, whereby the tail of a CHAIN may be in a non-theta position only if it is a subpart of a word.

The syntactic facts which have led previous researchers to consider Navajo to be nonconfigurational are considered in Chapter 4. These facts involve some curious restrictions on the interpretation of null pronominals, which seem to violate binding conditions. It is claimed that the data reveal a parallelism restriction on the assignment of Grammatical Relations, which is best handled if we treat the relevant constructions as Across-the-Board(ATB) constructions. This explanation is designed to capture and explain the original insight of those who proposed that Navajo has a parsing strategy, while showing that the differences between Navajo and more familiar languages are a matter of variation in independently available grammatical principles.

After an ATB account of the Navajo facts is presented in general terms, the question of the status of these representations in grammatical theory is addressed. It turns out that all of the constructions for which an ATB account has been proposed share the configurational properties of adjunction constructions. As was pointed out in Chapter 1, what is currently known about adjunction structures in general leads us to expect parallelism effects in just these constructions.

Thesis Supervisor: Kenneth Locke Hale

Title: Ferrari P Ward Professor of Linguistics

Acknowledgements

With all due respect to my thesis committee, I would like to begin my acknowledgements with an expression of gratitude which is, I am sorry to say, a few years too late. Adrian Akmajian, my first syntax teacher and advisor, profoundly influenced my thinking in every aspect of Linguistics. I will always be grateful that I was lucky enough to share some of his insight, enthusiasm and wit. If he were here, I'd thank him for laughing uproariously when I asked him what "Boolean Conditions on Analyzability" were (and also for actually explaining it clearly).

The members of my committee, Ken Hale, Noam Chomsky and Jim Higginbotham, have all taught me a great deal, about linguistic issues, and also about being careful, responsible and fair in work and life. Their influence in this dissertation is clear, but their influence on my life and work has only begun.

I also bear the mark of my other excellent teachers at the University of Arizona. Susan Steele, in particular, taught me what a linguistic argument should be. Dick Oehrle, Ann Farmer, Dick Demers, Ellavina Perkins and Adrienne Lehrer all taught me well.

In addition to the innumerable colleagues with whom I have shared ideas, random thoughts, complaints and inspirations, several faculty members, fellow students and visitors have made particularly valuable contributions to this dissertation. I am grateful to Richard Larson for useful discussion and encouragement, to Donca Steriade for clarifying many things, to Richard Kayne for insight, to Jay Keyser for word processors and much more, to Wayne O'Neil for approving, to Morris Halle for always making me go first, to Maggie Carracino and Nancy Peters for turkey and furniture and for keeping everything running smoothly, to Tova Rapoport for always being willing to listen to pre-presentation versions of various ideas and help me make them intelligible, to Maggie Browning for being brilliant, to Betsy Sagey for explaining Navajo pro-drop to me in our first year, to Andy Barss for extensive valuable last-minute comments on Chapter 1, and also for computerized marginalia, to Naoki Fukui, with whom I collaborated in developing many of the ideas in Chapter 1, for being so good-natured about sharing an office with my piles of books and papers, to Kyle Johnson, for hours spent as a sounding board, to various fellow Athabaskanists who shared ideas with me: Leslie Saxon, Ellavina Perkins, Michael Krauss and Jim Kari, to Laci Maracz, for interesting discussions of Configurationality, to audiences at WCCFL and at U.C. Berkeley, with particular thanks to Eve Sweetser, Charles and Lily Fillmore, and George Lakoff, also to those who made time for me during my brief visit to CSLI, in particular Bill Poser, Peter Reterson, Joan Bresnan, Paul Kiparsky and Susan Stucky.

It is thanks to my friends that I am ending up in a cap and gown instead of in a straightjacket. Thanks to Gabriel, Rita, Richard, Klaus, Maggie, Bob, Vila, Tova, Nigel, Dinette, Juliette, Kyle, Andy, Doug, Loren, Carol, Naoki, Betsy S, Betsy R, David, Alicja, Otto, GLITCH and the others. Also thanks to my co-inhabitants of the infamous Lawrence St. house: Jan, Mohammed, Jane, Lori, Lynn, Maggie, Bob, Colleen, Crispin, Mike and Gabe. Dick Carter also deserves mention as an honorary Lawrence.

I am grateful to the students, administration and other teachers at Navajo Community College for giving me the opportunity to work with them. I learned a great deal from Ellavina Perkins, Andrew Becenti, Blackhorse Mitchell, Martha Jackson, Lorene Legah, Lorraine Begaye, Mary Halwood, Betty Butler, Tony Goldtooth, Laura Wallace, Alice Neundorf and Roseann Willink.

The community of women in linguistics deserves a great deal of thanks, those who went before me and paved the way, as well as those who I have worked with during the past few years.

I thank my sisters Nancy and Kathy for constant moral support, and I dedicate this work to my parents for having me and for standing behind me no matter how far away I was.

TABLE OF CONTENTS

Abstract	2
Acknowledgements	4
Introduction	9
0.1 Modularity: Subsystems, Levels and Components	10
0.2 Internal and External Licensing Conditions	13
0.2.1 Relating the Levels	15
0.3 D-Structure	17
0.3.1 From Phrase Structure Rules to Licensing Conditions	17
0.3.1.1 X-bar Theory	19
0.3.1.2 INFL and the Headedness of S	20
0.3.1.3 The Specifier and Head of S'	23
0.3.1.4 The Theta Criterion	25
0.3.1.5 Adjuncts	26
0.4 The Relevance of D-Structure to Other Syntactic Levels	27
0.4.1 The Projection Principle Revisited	27
0.4.2 Barriers and L-Marking	31
0.4.3 Complete Functional Complexes as Binding Domains	32
0.4.4 Theta Positions in CHAINS	33
0.5 Parametric Variation	34
0.6 Overview of the Thesis	35
Chapter 1: Projection from the Lexicon	41
1.1 Local Relations and Projection	41
1.1.1 Thematic Grids	42
1.1.2 Discharge of Thematic Positions	48
1.1.2.1 Theta-marking	50
1.1.2.2 Theta-binding	53
1.1.2.3 Theta-identification	54
1.1.2.4 Autonomous theta marking	55
1.1.2.5 Adverbial Modification	56
1.2 Thematic Constituency	57
1.2.1 Phrase Markers	61

1.2.2	Headedness and Projection	72
1.3	Functional Categories	84
1.3.1	The Structure of IP and DP	91
1.3.2	Function Features	91
1.3.3	Deriving the Surface Order	95
1.3.4	The Spec Position	98
1.3.5	Some Consequences of the Proposal	101
1.4	The X-bar Schema	108
1.5	Adjunction Constructions are Three-Dimensional	116
Chapter 2:	Configurationality: Variation in the Projection of Structure	119
2.1	What is a "Nonconfigurational" Language?	119
2.1.1	A Digression about Word Order	125
2.2	Evidence for Dual Representations	129
2.2.1	Subject/Object Asymmetries	130
2.2.2	Warliri	145
2.2.3	Japanese	150
2.2.4	Hungarian	159
2.2.5	Malayalam	169
2.2.5.3	VSO Languages	179
2.2.6	Summary of Evidence	182
2.2.7	The Dual Representation Hypothesis	183
2.2.8	Pronominal Argument Languages vs. Lexical Argument Languages	186
2.2.9	Navajo Overt Nominals are in Argument Positions	196
Chapter 3:	Pronominal Argument Infixes	198
3.1	Navajo Prefixes and the Existence of Dual Representations	202
3.2	Interrupted Synthesis	203
3.3	Three Arguments for an Infixation Account of Navajo Verb Formation	204
3.3.1	Lexical Relatedness	207
3.3.2	Perfective Mode Choice and Da-Shift	211
3.3.3	Ni-absorption	222
3.3.4	Summary	227
3.3.5	Evidence for Concatenative Verb Formation	228
3.4	Infixes and CHAINS	232
3.5	Argument Positions	238
Chapter 4:	An Across-the-Board Account of Navajo Relative Clauses	244
4.1	Introduction	244

4.2 Navajo Sentence Structure	248
4.2.1 Simple Sentences	248
4.2.2 Relative Clauses	252
4.3 Parallelism in Relative Clause Constructions	254
4.4 An Across-the-Board Treatment of Navajo Relative Clauses	263
4.5 On the Inadequacy of a Simple pro-drop Account of Navajo	270
4.6 On Mapping Conventions	285
4.7 Formal Properties of ATB Representations	293
4.7.1 The Coordinate Structure Constraint	293
4.7.2 Williams (1978) ATB Format	294
4.7.3 Goodall (1984) Union of Phrase Markers	297
4.7.4 ATB Effects in Non-Coordinate Constructions	304
4.7.5 Other Parallel Constructions	306
4.7.5.1 Bella Coola	307
4.7.5.2 Hopi	311
4.7.6 The Navajo Case	313
4.7.6.1 Base Generation of Parallel Pronominals	314
4.7.6.2 LF Extraction and Parallel Variables	317
4.7.6.3 Adjunction, Embedding and Generalized Transformations	320

Introduction: Licensing at D-Structure

The goal of linguistic theory is to discover what it is that we know when we know a human language. In the view of Generative Grammmarians, a person who knows a given language knows both the vocabulary (lexical items) of that language and the principles for constructing sentences out of lexical items. A Grammar, then, is a system of principles according to which basic units of the vocabulary are related to one another.

This dissertation is devoted to an examination of the principles which generate and constrain well-formed underlying structures within the Government and Binding theory. Before presenting, in Chapter 1, a theory of the projection of structure from the lexicon, I will outline the basic principles of GB theory, and their organization, focussing on those principles which will be relevant for the remainder of the work. My intention here is to introduce the reader to the assumptions which I will consider crucial, and to present an introduction to the version of GB presented in Chomsky (1986 a and b).

0.1 Modularity: Subsystems, Levels and Components

The approach taken within Government and Binding Theory to the discovery of principles of human language has been a modular one: there are principles which are particular to language, and these distinct principles are thought to be grouped into subsystems, and to apply at various levels of representation. Such a modular view allows us to characterize language variation in terms of parameterization of a restricted set of principles of Universal Grammar (UG). UG, then, consists in a set of universal primitives over which linguistic relations are defined. These linguistic relations are constrained by the principles of the various modules.

It should be emphasized that GB theory is "modular" in (at least) the three different ways specified above. First, the linguistic system itself is viewed as a distinct module of cognition, in the sense of Fodor (1983). While there are certain conditions imposed on the Grammar in order to allow interface with other cognitive systems, the linguistic faculty is an autonomous system, in the sense that there are linguistic representations to which strictly linguistic principles apply. It should be noted that Chomsky (1986a, class lectures) has been careful to explain that he does not hold the view, which has been ascribed to him in various places, that syntax is 'autonomous' in the sense that it has no interaction whatsoever with any other linguistic or cognitive system. Rather, his position is that a restricted set of

distinct principles interact in various interesting ways, but this interaction does not imply non-discreteness.

The second type of modularity found in GB theory is the fact that the subsystems of grammatical principles are distinct, with each subsystem providing a particular type of constraint on the well-formedness of sentences.

- (1) SUBSYSTEMS OF PRINCIPLES
 (i) bounding theory
 (ii) government theory
 (iii) theta-theory
 (iv) binding theory
 (v) Case theory
 (vi) control theory
 (vii) X-bar theory

Chomsky(1981:5)

The principles of these subsystems each yield a partial representation of any expression, and their combination yields a complete analysis of any expression. An expression may be ill-formed due to a violation of only one principle; alternatively, several principles may be violated in a given expression.¹

Although these subsystems are distinct, they do interact. Conditions in one subsystem may be stated over vocabulary which is defined within a different subsystem. For example, the domains of application of the Binding Principles are stated in terms of structural configurations given by X-bar theory, and the assignment of Case is carried out either

1. Actually, because of the way in which the various principles interact, it is not simple to formulate an example in which one and only one principle is violated.

under a particular structural configuration or through association with the assignment of a particular theta-role.

The third sense in which GB theory is modular is that the subsets of principles apply at different levels of representation. In GB theory, there are 3 syntactic levels of representation plus a level of Phonetic Form, and these levels are organized as follows:

(2) LINGUISTIC LEVELS

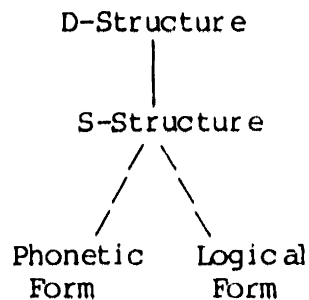

A well-formed expression must meet those conditions on relations which hold at each level. Furthermore, any particular category or constituent which appears at any level must be licensed at that level. We may state this condition on the appearance of elements at a given level in the following form:

(3) LICENSING PRINCIPLE:

- a. Every formative in a Phrase-marker² must be licensed.
- b. A node N is LICENCED iff N enters into one of the restricted set of linguistic relations.³

2. A phrase marker is an abstract representation of linguistic relations. The properties of Phrase markers will be discussed at length in the next Chapter.

3. I will be assuming in what follows that all of the D-structure linguistic relations are strictly local. In fact, for English it seems to be the case that all of the relations which license nodes at D-structure demand strict adjacency. The question of whether

Informally, this principle requires that every terminal and non-terminal node in a tree must have some purpose in the sentence. More particularly, every node must enter into a local relation which defines its participation in the sentence as a whole.

In the next section, I will briefly outline the licensing conditions which hold of PF, LF and S-Structure. I will then turn to a more in-depth discussion of the licensing conditions on D-Structure, since these are the conditions with which the remainder of the dissertation will be concerned.

0.2 Internal and External Licensing Conditions

Those well-formedness conditions which hold of a particular level in virtue of its status as a link with some other system of cognition are called "external" conditions, because they are influenced by the vocabulary of a module "outside" of the system of linguistic levels diagrammed in (2). The levels of Logical Form and Phonetic Form serve as links to systems of language use. In particular, Logical Form representations must be accessible to the semantic system, and Phonetic Form must be accessible to the articulatory and auditory systems. Therefore, both of these levels are subject to various constraining

long-distance relations such as the relation 'antecedent of' are base-generable or derived in the mapping from D-Structure to S-Structure is an empirical one which is still open. See Sportiche(1983), Brody(1984) and Chomsky(1985) on this issue.

principles in virtue of their status as links with these "external" systems.

The most general of these is the 'Principle of Full Interpretation':

(4) PRINCIPLE OF FULL INTERPRETATION(FI)

Every element of PF and LF must receive an appropriate interpretation.
(1986a:98)

This principle requires that all elements which appear at PF or LF must be interpretable in the particular system to which the level in question provides a link. For example, this principle forbids any elements in the ultimate PF representation of a sentence which do not show up in the uttered string. Similarly, no vacuous elements may appear in the LF representation of any expression. Chomsky points out that it is not logically necessary that FI should hold of natural language, and indeed it does not hold of many formal languages, as demonstrated by the fact that (5a) is a well-formed expression in the standard notations for quantification theory, which has the same interpretation as (5b).

(5) a. $(\forall x)(2+2=4)$ (for all x , $2+2=4$)

b. $2+2=4$

In addition to ensuring that no 'extra' or vacuous material appears at a given level, the licensing conditions require that each element which appears at that level have one of a restricted set of interpretations. For example, each segment at PF must correspond to one of the set of possible phonetic segments. Similarly, each terminal element at LF must be licensed as either an argument or trace of an argument, a predicate or an operator.

Thus we see that PF and LF provide an interface with other cognitive systems, and in that capacity, they conform to certain independent licensing conditions. Chomsky(1986a) addresses the question of whether S-Structure, which links the three other linguistic levels but is not related to any external cognitive systems, might also have independent licensing conditions. While he notes certain conditions which do seem to hold at S-Structure, such as conditions on syntactic 'chains', he speculates that "...these properties of S-Structure may be reducible to the independent conditions of FI holding of PF and LF representation and the conditions on D-Structure, given an appropriate account of the ways in which the elements of a structure $E = (D, S, P, L)$ ⁴ may be related." (1986a:101)

0.2.1 Relating the Levels

The four levels of representation are related through the rule 'affect alpha', which essentially allows constituents to be freely moved, added or deleted, as long as the resulting representation conforms to the appropriate licensing principles at each level. In addition to the conditions which hold at every level, the mapping from one level to another must obey the Projection principle, which requires that any element which is selected as a lexical feature at one linguistic level must appear at every linguistic level.

4. Where E is an expression, and D, S, P and L and D-Structure, S-Structure, PF, and LF, respectively.

In GB theory, basic sentence structure is considered to be a syntactic representation of certain properties of lexical items. This is assured by the Projection Principle, which states that "lexical structure must be represented categorially at every syntactic level." (Chomsky 1986a:84) Intuitively, the Projection Principle states that any arguments required by a lexical item at any one level must be represented categorially at all levels. Chomsky (1981) formalizes the Projection Principle as follows.

PROJECTION PRINCIPLE

Given :

i) $[_G \dots a \dots b \dots]$

ii) $[_G \dots b \dots a \dots]$

where a is an immediate constituent of G,

(i) If b is an immediate constituent of G at L_i , and $G=a'$, then a theta-marks b in G.

(ii) If a selects b in G as a lexical property, then a selects b in G at L_i .

(iii) If a selects b in G at L_i , then a selects b in G at L_j .

CHOMSKY (1981:38)

The Projection Principle is similar to the Principle of Full Interpretation, in that FI requires that every element which appears in a PF or LF representation be directly mapped to an appropriate interpretation, and the Projection Principle similarly requires that if some element is selected as a lexical feature at one linguistic level, the mapping to all other levels must maintain a representation of that element. The precise nature of the constraints imposed by the Projection Principle will be discussed in Section (0.4.1).

0.3 D-Structure

0.3.1 From Phrase Structure Rules to Licensing Conditions

The D-Structure level in current theory is the one which links syntax to the Lexicon. D-Structure representations are syntactic spell-outs of lexical properties, and as such are subject to a formal condition and a semantic condition. "The formal condition (on D-structure) is that it conform to the principles of X-bar theory (in general, representations at other levels do not conform to these principles...); the semantic condition is that it be a "pure" representation of the structure in the sense indicated..." (ibid.:100) These formal conditions are in some sense definitional of the mapping from the lexicon to D-Structure.

Notice that although Chomsky's Principle of Full Interpretation is intended to apply only to the levels of PF and LF, since these are the levels which interface with systems of language use, the semantic condition on D-Structure imposes a similar constraint on the mapping from the Lexicon to D-Structure. Any element which appears at D-Structure must be licensed by being some portion of the representation of thematic relations.

The theory of the relationship between lexicon and the syntax has undergone substantial development since the first work on Generative Grammar (viz. Chomsky 1955, henceforth LSLT). In LSLT, lexical items

were introduced by context sensitive phrase structure rule which replaced a category with a lexical item. No theory of the lexicon as such was developed. Chomsky(1965) introduced the separation of the lexicon from the phrase structure rules, which of course meant that some mapping was necessary between lexical representations and phrase markers. This mapping was effected by lexical insertion transformations which operated by matching the properties of a particular lexical item to the properties of the phrase marker.

Soon after the publication of Chomsky(1965), it was noticed that the practice of specifying properties on lexical items as well as on phrase markers led to a great deal of redundancy in the grammar. It was further noticed that the rules which generated phrase markers were redundantly stating various facts that held of all of the major categories (Noun, Verb, Preposition and Adjective).

In Chomsky(1970), a theory was introduced in which the separation between the lexicon and the syntax was made complete. The rules which generated syntactic structures were generalized with the introduction of the X-bar schema, and the Lexicalist Hypothesis, which maintained that the relationship between the lexicon and syntax was one of projection, and not of derivation, was introduced. Under the Lexicalist Hypothesis, the internal structure of complex derived (as opposed to inflected) words was not accessible to syntactic processes, and the properties of words could not be changed in the course of a syntactic derivation.

The role of phrase structure rules in generating phrase markers has

been steadily diminishing as Generative theory has developed, while the role of lexical properties has been increasing. Stowell(1981) articulated the line of thought introduced in Chomsky(1981), that phrase structure rules could be eliminated totally, in favor of schematized X-bar principles, which constrained the form of structures which would result from projecting (i.e. giving syntactic representations to) lexical representations.

0.3.1.1 X-bar Theory

Stowell(1981) showed that if the Phrase Structure rules which generate D-Structures are category-neutral, we can actually eliminate the categorial component of the grammar, and consider the X-bar schema to be a set of well-formedness conditions on phrase markers. As Stowell points out, the set of restrictions imposed by X-bar theory may be rendered in the notation of trees or schematic Phrase Structure rules, but it is in no way dependent upon this notation. Chomsky(1986b) expresses the X-bar principles as in (6).

$$\begin{array}{l}
 (6) \quad X' = X \ X''^* \\
 \quad \quad X' = X^* \ X' \qquad \qquad \text{(order irrelevant)} \\
 \qquad \qquad \qquad \qquad \qquad \text{(Chomsky 1986b:3)}
 \end{array}$$

With Stowell's elimination of the categorial component of the grammar, D-Structures are to be defined as a projection of the thematic structure of a lexical category, constrained by X-bar theory. That is, thematic roles assigned by particular verbs are represented categorially in the syntax, and their configuration at D-Structure must adhere to the general template given by the X-bar well-formedness

conditions. The dominance and precedence relations within a given category were shown to follow from independent principles of the Grammar, such as a general adjacency requirement for assignment of Case, parameterized specification of the direction of assignment of Case and theta role, etc.

Underlying Stowell's proposal that the X-bar conditions constrain the structural spellout of lexical properties is an assumption that the principles of X-bar theory are inherent to the language faculty, that is, that they constitute an innate 'program' restricting the possible hypotheses which the language learner could formulate about the structure of any language. According to Stowell, "the task of acquisition is limited to the development and elaboration of the categorial identity and mutual ordering of the terms at each hierarchical level" (1981:71) In other words, the language learner must learn what the categories are in his/her language, and must learn the precedence relations holding of terminal and non-terminal elements, but the internal structure of each category, i.e., the domination relations, are given by the X-bar principles.

0.3.1.2 INFL and the Headedness of S

Linguists interested in the nature of syntactic categories have devoted considerable attention to the status of the category AUX or INFL, and to the related question of the headedness of the category 'S'. Although the earliest developed X-bar systems, such as Jackendoff (1977) take S to be a projection of V, Chomsky (1981) takes

the position that INFL is the head of S.⁵

The hypothesis that INFL is the head of S is simultaneously an hypothesis about the existence of INFL as a syntactic category and about the participation of S in the X-bar schema.

The existence of INFL as a category at D-Structure is not a-priori necessary, given the definition of D-Structure as a spellout of thematic properties. If INFL does not have thematic properties, or participate in the spellout of thematic properties, then its existence at D-Structure may be called into question. In fact, Chomsky (1986a) suggests that "it would be reasonable to assume that lexical items appear at [D-Structure] in a 'reduced' form lacking inflectional elements that do not affect theta-marking and do not enter into s-selection." (1986a:157) His proposal is that inflectional morphology may be inserted at a later level, but that the INFL node, which dominates the abstract features for TENSE and AGREEMENT does appear at D-Structure as the head of S, since this node enters into s-selection insofar as its features are selected by certain verbs which take sentential complements.⁶

Furthermore, according to Chomsky, the INFL node, being the head of

5. To my knowledge, the first to work out an explicit proposal to this effect was Jeanne (1978), who analyzed Hopi sentences as being headed by AUX.

6. It is clear that certain verbs select for the tense of their complements, but it is not as obvious that any verbs select for agreement. A possible case of selection for agreement would be the obviation effect found in subjunctive complements.

S, is licensed by X-bar theory, which requires that all categories have a head.

Williams(1983) goes a step further, arguing that the parallelism between NP and S is illusory, and that their internal structure is fundamentally different, in that NP is headed by N, while S is exocentric. Thus, VP but not S adheres to the X-bar principles. In Williams' theory, the subject-object relation would be simply a predication relation between two maximal projections. The subject would be required, as in Chomsky's theory, because of the condition on LF that predicates must have subjects.

Williams doesn't address the question of the structural position of INFL. We might take INFL to be the specifier of VP under Williams' general proposals, which would regularize the structure of VP to conform to that of the other categories. As far as I know, no existing scope facts give evidence that tense might not be an operator with scope over the VP. One problem with this, however, is that tense features must be available for complement selection. If it turns out, as suggested in Rizzi (1981) that complement selection is for head features only, then the features of INFL must somehow end up on S. I believe that Williams considers tense a feature which may simply percolate up to the S node, rather than (part of) a constituent.⁷

7. Interestingly, Williams(1981) proposes a theory of the Lexicon in which inflectional affixes are the heads of words. He follows Lieber in assuming that affixes have subcategorization frames. If his proposal is right, then we might suppose that this head-complement relation is projected from the lexicon, resulting in an S headed by

Another problem with the proposal that S has no head is that it eliminates an available explanation for the class of phenomena which have recently been viewed as sub-cases of a general rule of head-to-head movement. Recent work by Koopman(1984), Travis(1984) and Baker(1985) on this topic has been quite fruitful, and the varied processes that they explain by assuming a restricted head-to-head movement would be left unaccounted for if we adopted Williams' suggestion.

There is, however, evidence of cross-linguistic variation with respect to the headedness of S. Taraldsen(1983), for example, proposes that V is the head of S in Norwegian, while INFL is the head of S in English and Romance. Saito(1984) and Fukui(1986) show that Japanese facts are best accounted for under the assumption that V is the head of S in that language. Fukui and Speas(1986) argue further that variation between Japanese and English can be attributed to the general lack of non-lexical categories in Japanese.

0.3.1.3 The Specifier and Head of S'

The features of COMP (+/-wh) enter into s-selection, so presumably the maximal projection of COMP is licensed at D-Structure by being assigned a theta role, while the head of COMP is licensed by X-bar theory, since all categories must have unique heads.

INFL. This would mean that D-Structure is simply a projection of lexical structure, including projection of the subcategorization requirements of INFL.

Chomsky(1986b) points out that under previous accounts of the structure of S' (such as that in Chomsky(1981)), S' was a defective category with respect to X-bar theory, in that it had no specifier position.⁸ He proposes that the projection of COMP at D-structure is in fact fully articulated. The head of COMP, COMP⁰, may be realized in English as that, for or 0, and all cases of move-alpha which move XPs in syntax move them to the specifier of C":

(7)

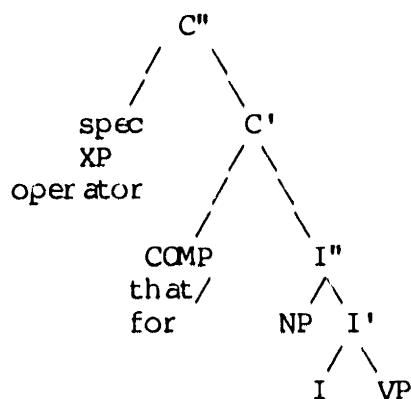

The position of non-lexical or functional categories at D-structure is less straightforward than the above diagrams would make it seem. I will take up this topic in detail in Chapter 1, where I will review the proposal of Fukui and Speas(1986) that some languages lack non-lexical categories.

The categories and constituents, then, which must be licensed at D-Structure include heads, maximal projections, and intermediate projections. According to Chomsky, heads are licensed by projection

8. Unless a base generated topic position could be considered to be the spec of S'

from the lexicon. Formally, an X^0 is the syntactic representation given to any lexical item. 'Projection' from the lexicon takes a lexical item and assigns it a syntactic representation.

As for maximal projections, recall that at Logical Form, "we might expect that each phrase alpha must be licensed 'externally', as either an argument or the trace of an argument, a predicate or an operator." (Chomsky 1986a:100) Notice that with licensing conditions such as these, we may say that there are no longer arbitrarily generated positions into which lexical items are inserted, as there were in earlier theories. Instead, positions exist only when they instantiate or enter into one of the limited set of permitted syntactic relations.

0.3.1.4 The Theta Criterion

Chomsky(1986a) states the Theta Criterion informally when he says, "D-structure may now be defined as a "pure" representation of theta-structure: Each argument is in a theta-position and each theta-position is occupied by an argument, where an argument is a phrase that must be assigned a theta-role to satisfy the licensing conditions. (1986a:155)"⁹

9. The requirement which has been called the Extended part of the Extended Projection principle, namely, the requirement that all sentences have a Subject, is supposed to follow from a licensing condition on predicates: all predicates must have a subject. Chomsky adopts the formulation of this requirement from Rothstein(1983).

Chomsky(1981, 1986a) points out that the Theta Criterion is more accurately expressed in terms of argument chains rather than arguments. Chomsky(1981) gives the following more precise formulation of the theta criterion, noting that "this is only a sketch of a true formalization." (1981:335)

(8) **THETA-CRITERION**

Given the structure S, there is a set K of chains $K = \{C_i\}$, where $C_i = \{\alpha_1^i, \dots, \alpha_{n_i}^i\}$, such that:

- (i) if α is an argument of S, then there is a C_i in the set K such that $\alpha = \alpha_j^i$ and a theta role is assigned to C_i by exactly one position P.
- (ii) if P is a position of S marked with the theta role R, then there is a C_i in the set K to which P assigns R, and exactly one α_j^i in C_i is an argument.

Notice that both the formal and informal statements of the Theta Criterion allow a situation in which a single NP receives different theta roles from different predicates, as long as exactly one position assigns a theta role to a given chain, and there is a chain (containing exactly one argument) for every theta-marked position. The NPs underlined in (9) and possible examples of multiple theta role assignment to a single position.

- (9) a. John left the room angry.
- b. We wiped the dishes dry.

0.3.1.5 Adjuncts

Another type of elements about which the definitions of D-Structure have nothing to say are adjoined constituents, such as those underlined

in (10).

- (10) a) We built a doghouse in the garden.
b) The thick yellow book with the torn cover is the one I wrote.
c) John left because he was tired.
d) This is the paper that I filed without reading
e) The computer that I'm using keeps beeping.
f) As for Susan, if she doesn't get here soon, I'm leaving.
g) Juliette ran at a steady pace until the final mile.
h) John served the wine with strawberries in it.
i) John served the wine with gloves on.

It is generally assumed without comment that the above underlined constituents are present at D-Structure. However, since none of them are part of the matrix verb's thematic requirements, it is not clear whether any of them are present at D-Structure, and if so, how they are licensed. Of course, the definition of D-Structure as a "pure" representation of a verb's theta requirements does not rule out extra adjoined elements, as long as the verb's theta requirements are properly fulfilled, it is important to note that the structural status of adjoined elements is largely unknown. I will address this issue in Chapter 1.

0.4 The Relevance of D-Structure to Other Syntactic Levels

0.4.1 The Projection Principle Revisited

The Projection Principle, as stated in Section 0.2, constrains not only the mapping between syntactic levels, but the mapping between the lexicon and syntax as well. Crucial to our understanding of the constraints imposed by the Projection Principle is a precise conception

of what it means for a lexical item to select an argument. If we accept the view that a given argument may be designated in the lexical entry as an external argument, then the projection principle has the effect of assuring the structural asymmetry between Subject and Object throughout the derivation. In other words, the Projection Principle allows structure to be projected from the lexicon, and also restricts the elements which fill structural positions.

As noted above, there is evidence that in addition to adhering to a condition such as the above which requires continuity of thematic structure throughout a syntactic derivation, Universal Grammar may include some extension of the Projection Principle, which may be described as follows:

(11) Every clause has a subject.

Chomsky (1981, 1984) cites expletives as evidence that subjects are required at D-structure. "If the bracketed phrases in such constructions (as "it [is raining]") did not require subjects for some general reason, it is not clear why the semantically empty elements it, there should appear at all." (1984:161) So the presence at S-structure of elements which seem to simply fill positions which are not licensed by theta-theory at D-Structure (i.e. are not part of the verb's GF-theta) suggests that the position must be obligatory.

The other piece of evidence cited by Chomsky involves the structures in English in which an overt subject does not appear, i.e. gerunds and infinitives. Chomsky points out that such phrases do have "understood" subjects. That is, the position seems to receive an interpretation at

LF, and it seems to get an independent theta-role.

Further, Beletti and Rizzi give evidence that there must be an external argument, even in languages without overt pleonastics, further supporting the "extension" of the Projection Principle.

Since the Projection Principle is stated in terms of selection as a lexical property, it does not necessarily require that the subject appear at all levels simply because it appears at one level. So, for example, it may be the case that pleonastics are added or deleted, depending on the licensing principles which hold at a particular level.

Chomsky suggests several "general principles" which could provide the explanation for the apparent obligatoriness of subject. Perhaps X-bar theory simply includes a spec position for every category. Or Perhaps the reason is semantic. VPs are unsaturated predicates, and semantic principles require that they be saturated (see Rothstein 1983). The third possibility is a syntactic one, suggested by Fabb(1984): Verb phrases need Case, and thus there is a syntactic licensing relation between INFL and VP which is parallel to the one between INFL and the subject.

In sum, the Projection Principle encodes the following constraints on the form of the Grammar:

1) The Projection Principle has the effect of prohibiting any syntactic rules which would add or delete syntactic positions. Thus, if a verb is lexically listed as transitive, then we assume that two

argument positions exist for that verb throughout the syntactic derivation. For example, the verb see is listed in the lexicon as being transitive, that is, as selecting an object as a lexical property. When the passive morphology is added, the Projection Principle constrains the possible ways that the changes wrought by this morphology may be expressed in the theory: we cannot say that the object position has been deleted, even though no overt NP shows up in object position on the surface. Instead, we assume that the D-Structure for (12a) must be (12b).

- (12) a. Mary was seen.
b. (e) was seen Mary.

Independent principles of Case assignment result in the NP Mary, which is assigned the object theta role at D-Structure, to move to Subject position. By the Projection Principle, this movement must leave a trace in object position:

- (13) $Mary_i$ was seen t_j .

2) If a sentence is understood (i.e. interpreted at LF) as including a particular argument but that argument is not spelled out phonetically, we assume the presence of an empty element. For example, we assume that the syntactic representation of a sentence like (14) includes an empty subject for the verb leave because that verb is understood as having a subject.

- (14) Mary wants to leave. (= Mary wants Mary to leave)

3) If a verb designates one of its arguments as "external", then that

argument must be dominated by a node which is not a projection of the verb. This last constraint is explicit in the formulation of Williams, and I think in the conception in Hale(1983) of Chomsky(1981)'s Projection Principle. This constraint results from the fact that the Projection Principle forbids changing a verb's lexical properties, and this designation of one argument as external is a lexical property.

0.4.2 Barriers and L-Marking

As has so often been noted, in a modular theory of grammar, any change in one module may have far reaching effects in other components. So, for example, a change in the D-Structure definition of a "maximal projection" or in the inventory of lexical categories may effect the well-formedness of movement operations, since the definitions of government, Barrier (for movement) c-command, etc, are stated in terms of structural configurations, which are in turn constrained by X-bar theory. Chomsky(1986b) gives the following definitions.

(15) **GOVERNMENT**

A governs B iff A m-commands B and every barrier for B dominates¹⁰ A.

(16) **M-COMMAND**

A m-commands B iff A does not dominate B and every G, G a maximal projection, that dominates A dominates B.
(Chomsky 1985:6)

10. See Chapter 1 for a discussion of Chomsky's definition of dominates.

(17) **BARRIER**

A is a Blocking Category(BC) for B iff A is not L-marked and A dominates B.

A is a Barrier for B iff (i) or (ii):

(i) A immediately dominates s, s a BC for B

(ii) A is a BC for B, A not equal to IP.

Chomsky(1985b:11-12)

(18) **L-MARKING**

A L-marks B iff A directly theta-marks B and A is a Lexical head.

(19) **DIRECT THETA-MARKING**

A directly theta-marks B iff A theta-marks B and A and B are sisters.

0.4.3 Complete Functional Complexes as Binding Domains

Similarly, the general binding conditions, (20) are stated in terms of a 'local domain', which is in turn defined in terms of maximal projection and grammatical functions.

- (20) (A) an anaphor is bound in a local domain
(B) a pronominal is free in a local domain
(C) an r-expression is A-free (in the domain of the head of its chain)

(Chomsky(1986a:166)

(21) **LOCAL DOMAIN = MINIMAL GOVERNING CATEGORY**

... a governing category[for an anaphor or pronominal a is a maximal projection containing both a subject and a lexical category governing a (hence, containing a). A governing category is a "complete functional complex (CFC) in the sense that all grammatical functions compatible with its head are realized in it. (ibid.:169)

Clearly, since the binding principles refer crucially to domination

relations, any proposal that a given language differs from English with respect to domination relation makes the prediction that the range of possible coreference relations will be different.

0.4.4 Theta positions in CHAINS

Chomsky defines CHAIN as "the S-Structure reflection of a 'history of movement'" (1986a:95), or an expletive...argument pair, and proposes a descriptive restriction on the location of a theta position within a CHAIN.

(22) CHAIN CONDITION:

If $C = (a_1, \dots, a_n)$ is a maximal CHAIN, then a_n occupies its unique theta-position and a_1 its unique Case-marked position. Chomsky (1986a:137)

This condition disallows any CHAIN in which the head is in a theta position as well as any CHAIN in which tail is in a case marked position. As Chomsky discusses at some length, the CHAIN Condition follows from the interaction of independent principles of the Grammar, in particular from the Theta Criterion and the Visibility Condition.

(23) THETA CRITERION: A CHAIN has at most one theta-position; a theta-position is visible in its maximal CHAIN.
(Chomsky 1986a:135)

(24) VISIBILITY CONDITION: Every member of a properly Case-marked CHAIN is visible for theta marking.

If the head of a CHAIN were to occupy a theta-position, then, by the theta criterion, the tail would have to occupy a non-theta position. This state of affairs is impossible according to Chomsky, because a theta position cannot be generated at D-structure without an argument

in it. Since D-Structure is by definition a pure representation of theta-relations, there can be no "truly empty" theta positions at D-Structure. Any D-Structure Theta positions must have either an overt argument or a phonetically null argument which possesses the features +/-pronominal, +/-anaphor.

Furthermore, "since the D-Structure position of an argument is a theta-position by definition, it follows that an argument cannot be moved to a theta-position or the chain so formed will have two theta-positions." (Chomsky 1986a.136)

0.5 Parametric Variation

In such a modular theory of grammar, cross-linguistic variation may be explained in one of three ways:

1) Individual entries in the list of lexical items in a given language may contain various types of idiosyncratic information. Of course, the phonetic representation of a particular lexical item is one piece of information which is idiosyncratic. Other arbitrary lexical information would include mismatches between morphological form and features, as in (1), mismatches between morphological and syntactic form and meaning as in (2), membership in word classes such as gender, as in (3), idiosyncratic facts about complement selection, as in (4), etc.

(25) The sheep is/are grazing.
The fish is/are nervous.

(26) Your pants are on the floor.

These scissors are dull.

(27)	FRENCH			SPANISH	
	le printemps	(M)	'spring'	la primavera	(F)
	la poussière	(F)	'dust'	el polvo	(M)
	la sandwich	(F)	'sandwich'	el sandwich	(M)

- (28) I gave the Salvation Army some clothes.
*I donated the Salvation Army some clothes.
Mary considers John to be foolish,
*Mary thinks John to be foolish.

2) Many of the principles of UG are multivalued, and each language will select a particular value. For example, the principle that all categories must have a unique head is thought to be a universal principle, but languages vary as to which part of speech is considered to be the head of the S constituent.

3) A given principle of UG may apply at different linguistic levels in different languages. For example, while it is, by hypothesis, universally the case that WH words must move in order to take scope, languages differ according to whether WH-movement applies at S-Structure as well as Logical Form, (eg. English) or in Logical Form only (eg. Chinese, Japanese).

The question of the locus of explanation of observed variation is an empirical one, to be resolved only by detailed investigation of the way that proposed universal principles operate in particular languages.

0.6 Overview of the Thesis

The issues to be addressed in this thesis are those which have been left open in the theory of underlying structures. In particular, I will provide a theory of projection from the lexicon which is intended to complete the transition from rules to principles with respect to underlying representations, and I will address the central problems in the study of parametric variation in the projection of underlying structure.

0.6.1 Chapter 1

In this chapter, I outline a theory of the D-Structure level of representation in which all well-formedness relations imposed on underlying structures are deducible from other independent principles of the Grammar. This theory extends the work of Stowell. Whereas Stowell argued that linear precedence relations could be derived from independent principles, my proposal is that domination relations may likewise be derived from independent principles.

First, I give an overview of the theory of lexical representations of Higginbotham (1985, 1986), in which words of all lexical categories (N, V, A, P) are thought to have a 'theta grid' as part of their lexical entry. I argue that the relations which hold among these grids are sufficient to give all the information that we need to deduce the domination relations which result when these lexical entries are projected from the lexicon into the syntax.

After discussing the properties of phrase markers in general, I show how Higginbotham's lexical representations are projected, proposing

that this projection builds 'Thematic Structures'. Thematic Structures are universal abstract relational structures, which encode domination relations, which are derived from thematic relations, but do not encode precedence nor do they encode adjacency.

Following Higginbotham, I maintain that modifiers and secondary predicates have their own thematic properties to be spelled out at D-Structure, so they are present at D-Structure by definition.

It is not as clear that non-lexical categories have thematic properties, therefore the presence of these categories at D-Structure is not a priori necessary. I propose that non-lexical or 'Functional' categories are heads at D-Structure, but that the way that they project differs in significant ways from the way that lexical categories project. In particular, functional categories lack a specifier position at D-Structure, and they project to XP if and only if they have a particular type of feature, a 'Case' feature, to discharge. This section is essentially a presentation of the proposal in Fukui and Speas (1986).

I go on to compare my projection proposal to the X-bar schema, arguing that in fact, my proposal moves closer to capturing the true generalizations about the structure of syntactic categories.

I end the first Chapter with a discussion of the properties of adjunction constructions, pointing out that the claims of May (1985) about domination relations in LF adjunction structures lead to the conclusion that such structures are always three-dimensional.

0.6.2 Chapter 2

In the second chapter, I explore the parameters of variation which have come to be associated with the term "Configurationality Parameters." These are the parameters which determine variation in underlying structure.

There are two related issues which are discussed under the this rubric. One is the question of whether all languages distinguish structurally between subject and object. In order to clarify this sub-issue, I bring together the diverse data which have been adduced as evidence for variation in configurationality. While it is often assumed that "nonconfigurational" languages are those with 'flat' structures, the data actually seem to call for some sort of dual representation. After presenting the evidence, I discuss the 'dual representation hypothesis' of Hale and his colleagues.

I then turn to a discussion of the other issue, showing that it is related to, but independent of, the issue of underlying domination relations. The proposal of Jelinek(1984) that the Configurationality parameter should be stated in terms of the status of overt nominals as adjuncts and of pronominal clitics as arguments is on the right track, I maintain, but it makes the wrong prediction in certain cases, and it could allow violations of the Projection Principle.

The language which I use as a case study is Navajo. It has been proposed that Navajo overt nominals are actually adjuncts, and that

pronominal clitics are the 'real' arguments. There are two problems with this. First, by standard syntactic tests, overt nominals do not behave like adjuncts, they behave like arguments. Second, the pronominal clitics are embedded within an apparently unstructured string of prefixes, and it is not obvious that they are accessible to syntax at all, let alone in argument positions.

0.6.3 Chapter 3

In this Chapter, I consider in detail the status of the Navajo prefixes which mark subject and object agreement. I give arguments that these agreement prefixes must be infixes, that is, that they must be inserted into a discontinuous lexical item.

If this infixation model for Navajo is correct, then the problem of the accessibility of the pronominal agreement clitics in the syntax is not so serious, in fact it might be proposed that they are in argument positions at D-Structure and S-Structure, and simply infix at PF. However, such a proposal would contradict the syntactic evidence that overt nominals are in argument, not adjoined, positions. As a solution to this problem, I suggest an extension of the definition of an allowable syntactic CHAIN, whereby the tail of a CHAIN may be in a non-theta position only if it is a subpart of a word.

0.6.4 Chapter 4

I turn from the investigation of Navajo morphology to the syntactic facts which have led previous researchers to consider Navajo to be

nonconfigurational. These facts involve some curious restrictions on the interpretation of null pronominals, which seem to violate binding conditions. I claim that the relevant data reveal a parallelism restriction on the assignment of Grammatical Relations, which is best handled if we treat the constructions in question as Across-the-Board(ATB) constructions. This explanation is designed to capture and explain the original insight of those who proposed that Navajo has a parsing strategy, while showing that the differences between Navajo and more familiar languages are a matter of variation in independently available grammatical principles.

After showing in general terms how an ATB account of the Navajo construction works, I address the question of the status of these representations in grammatical theory. It turns out that all of the constructions for which an ATB account has been proposed share the configurational properties of adjunction structures. As pointed out in Chapter 1, what is currently believed about adjunction structures in general leads us to expect parallelism effects in just these constructions.

Chapter 1

Projection from the Lexicon

1.1 Local Relations and Projection

In this chapter I will outline a theory of the D Structure level of representation in which local licensing relations yield hierarchical structure. Extending the work of Stowell(1981), who showed how linear precedence relations in language are deducible from independent principles I will maintain that domination relations may also be so deduced. This theory answers certain questions about D-Structure representations which have been left essentially open in the transition within Generative Grammar from rules to principles.

In particular it provides an account of those categories and constructions whose status at D-Structure is left unclear under the accepted definition of D Structure as "an abstract representation of semantically relevant grammatical relations such as subject-verb verb object, and so on"(Chomsky(1986a:67). Under this informal definition, the status of adjoined modifiers, for example, which are additional to the elements which express the 'core grammatical relations, is left open. Also, inflectional elements, which do not

affect theta marking, may not be present at all. In fact, although it is currently accepted in Government and Binding theory that the non-lexical category INFL is the head of the S constituent, the strongest interpretation of the statement that D Structure is a spellout of those properties of lexical items having to do with semantically-relevant grammatical relations will exclude from D-Structure any elements which do not participate in the core grammatical relations. Thus, it is not at all clear how the INFL node can be licensed at D-Structure.

Within the theory of D Structure that I will propose, adjoined modifiers will be integrated into the projected structure, insofar as they themselves bear a theta relation to the modified constituent. INFL will be present at D-Structure as a non-lexical or Functional head. I will argue, following Fukui and Speas(1986), that in the underlying structure of English INFL is external to the projection of the verb, and that this projection of the verb contains all of the verb's arguments

My proposal will be based on the theory of lexical representations proposed by Higginbotham (1985, 1986). I turn now to an exposition of Higginbotham's framework.

1.1.1 Thematic Grids

Stowell(1981), pointing out that the notion of a thematic role is directly related to the argument structure of a logical predicate, in the sense that "a function name assigns a theta role to each of its

arguments" (1981:34), proposed that a verb's lexical entry contains a thematic or theta grid, which is a representation of that verb's argument structure.

Higginbotham (1985-1986) extends Stowell's conception of theta grids suggesting that not only verbs, but all lexical items of the major lexical categories (Noun, Verb, Adjective, Preposition) have a theta grid associated with them. The theta grids (enclosed in angle brackets) which he proposes for the +/-N, +/-V categories are given in (1.1)¹.

(1.1)	V:	hit	+V-N	<1, 2, e>	Agent (1), Patient (2)
	A:	happy,	+V+N,	<1, e>	Theme (1)
	N:	book,	-V+N	<1>	
	P:	in	-V-N	<1, 2, e>	

Higginbotham refers to the numbers notating roles to be assigned as positions in the thematic grid. This generalization of thematic grids to all lexical categories contributes to Higginbotham's overall research project in that it allows him to suggest a systematic approach to the problem of deducing the principles of interpretation for complex syntactic structures from the meanings of words. Each word has a theta grid as part of its lexical entry, and complex expressions receive their interpretations through the application of a restricted set of operations which result in the discharge of the positions in the theta grids, where discharge is defined (informally) as, the "elimination of open thematic positions in lexical items and in complex

 1. The position designated by e is an event position, which Higginbotham adopts following Davidson (1967). The motivation for this position will be discussed below.

phrases". (Higginbotham 1986:14)

Consider first the thematic grid for the noun. A noun like dog for example, denotes each of the various dogs in the domain of discourse. Therefore it would, in Higginbotham's theory, have as part of its lexical entry a theta grid containing one open position, as shown in (1.2) (H's (29)).

(1.2) dog, -V +N, <1>

In construction with a definite determiner, this theta position is bound and hence discharged, as shown in (1.3), where the asterisk indicates that the thematic position which was open in N' is not open in NP.

(1.3)

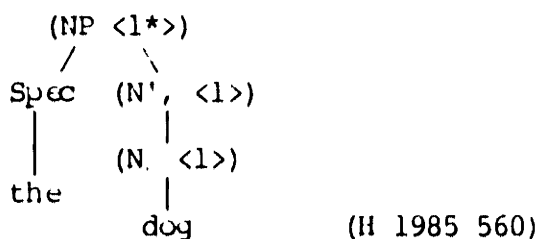

Other types of nouns may have additional positions. For example, a body part noun such as arm has as part of its meaning the fact that any arm inherently belongs to someone, and a kinship term like mother has as part of its meaning the fact that any mother is by definition the mother of someone. The question of the existence of some particular position as part of the theta grid of a lexical item is ultimately an empirical one; much of what we know when we know the meaning of a word has no relevance to syntax, and therefore is not encoded in the theta grid, to be spelled out in syntax. Of course, it is not always a straightforward matter to decide which parts of a word's meaning do and

do not have direct relevance to the syntax. In the case of body parts and kinship terms, data from other languages seems to confirm the hypothesis that the relational aspects of these terms have direct syntactic relevance. Other cases are not so clear

In the thematic grid for the verb, the numbers 1 and 2² stand for the thematic roles ultimately assigned to the subject and object respectively. This much is uncontroversial. In addition to the standard thematic positions, Higginbotham argues that the theta grids of ordinary predicates, including stative verbs and adjectives, include an event position. In incorporating an event position into the thematic grid of the verbal lexical entry, Higginbotham is giving an explicit representation to the "hidden" argument place for events originally proposed by Davidson(1967).

Higginbotham (1986) discusses the motivation for and consequences of the postulation of this event position in some detail. Davidson(1967) originally proposed such a position in order to give a straightforward account of the contribution to a sentence of instrumental and other adjoined phrases in terms of modification of an event.

The assumption that such a position is included in a verb's theta

2. Although Higginbotham uses numbers as the notation for theta positions, the subject and object grammatical functions are definable in structural terms in his theory. For this reason these numbers should not be construed as the '1' and '2' grammatical relations of Relational Grammar. In another sense which will become clear during this chapter, the proposal I am making involves relations which are primitive, but subject and object are definable in terms of these primitive relations.

grid allows the semantic value of an ordinary predicate to be stated clearly in such a way as to illuminate the contribution of the individual verbal lexical item to the complex construction. For example, the various positions in the minimal lexical entry for the verb walk, shown in (1.4a), could be discharged in such a way as to yield the interpretation shown in (1.4b) (ignoring tense see Schein(1985) for extensive discussion of the interaction of INFL and the event position.).

- (1.4) a. 'walk', (+V -N), <1, e>, Actor(1)
 b. (Ee) walk(John, e)

The above lexical entry is to be interpreted as.

'walk' is a binary verb, true of a thing x and an event e just in case e is a walking by actor x.

If the theta position designated as that assigned the role of actor is discharged by assignment to the NP John and the event position is existentially bound³ then the correct interpretation results.

 3. It is unclear to me how Higginbotham intends to restrict the appearance of these non-overt existential bindings, so that the theta criterion is not rendered vacuous. The existential binding of the event position does seem motivated semantically, since, for example, the sentence 'John walked' is true iff a walking event existed and it involved John. However, it seems to me that Higginbotham's theory would allow a sentence like (i), with the meaning shown in (ii).

- (i) Dog bites.
 (ii) (Ex) dog(x). x bites

In this case the theta position in the noun is existentially bound, thus discharged. What is needed is a restrictive theory of what counts as appropriate existential binding.

In addition to allowing a practical formalization, assuming an event position leads to a systematic account of the semantics of the so-called 'root-related homonyms', that is, minimal pairs which seem to have identical underlying forms but are not synonymous, such as those discussed by Fillmore(1968):

- (1.5) a. The bees were swarming in the garden.
b. The garden was swarming with bees.
c. swarming [garden] [bees]
 locative dative

The semantic difference between these two sentences is that in sentence a the bees must be flying in a compact group but may be in only one part of the garden while in b, the bees must fill the garden, but need not be in a compact group. This difference can be captured by appealing to the relationship between the surface subject and the event position. In sentence a, the swarming event must crucially involve the bees, while in sentence b, the swarming event must crucially involve the garden.⁴

4. Higginbotham(1986) leaves open the question of whether the requirement of thorough involvement of the subject ought to be part of the definition itself, or a semantic property that arises from the syntactic configuration in which the verbs are placed, commenting that one may remain agnostic on this issue for present purposes. This question is not at all trivial, since the requirement that the subject (or external argument) be thoroughly involved in the action does not seem consistent with the hypothesis that syntax and semantics have their own distinct vocabularies and principles. In order to be consistent with this hypothesis, we must be sure to state this requirement as a principle which interpretes particular structures or which spells out structurally certain interpretations, but we must avoid a rule which, say, stipulates that the external argument gets some given case only if it is thoroughly involved in the action.

A third important motivation for the event position is the fact that it allows a simple treatment of adverbs which is fully in accordance with the treatment of other lexical categories. This treatment, as elaborated in Higgins(1986) will be discussed further in the following section.

1.1.2 Discharge of Thematic Positions

Higginbotham proposes that the theta criterion of Chomsky(1981), which is shown in (1.6), may be restated in terms of discharge of positions in the theta grid.

- (1.6) Each argument bears one and only one theta role, and each theta-role is assigned to one and only one argument.

(Chomsky 1981:36⁵)

- (1.7) a) Every thematic position is discharged.
b) If X discharges a thematic role in Y, then it discharges only one⁶.

(Higginbotham 1985:561)

As mentioned above, discharge is defined as the elimination of open thematic positions in lexical items and in complex phrases. Notice that Higginbotham's Theta Criterion specifies that X may discharge only one role in Y. He states it in this way in order to allow possible cases where a given NP may discharge different theta roles in different

5. See the Introduction for a discussion of Chomsky's more formal statement of the Theta Criterion.

6. Both Chomsky and Higginbotham are careful to emphasize that parts a and b constitute separate subparts of the theta-criterion, each of which are independently open for empirical investigation.

predicates, some examples of which were given in Section 0.3.

There are four basic modes of discharge, all of which Higginbotham says take place in the configuration of government. Below I give his descriptions of the four basic modes of discharge. Actually, in all of the examples which Higginbotham uses to illustrate theta discharge, the appropriate mode of discharge takes place under strict sisterhood. In what follows, I will be assuming that theta discharge takes place under strict sisterhood, which I define as in (1.8)⁷.

(1.8) **STRICT SISTERHOOD**

A and B are strict sisters iff neither dominates the other and every G, G a branching node, which dominates A dominates B.

(1.9) **BASIC MODES OF DISCHARGE:**

- (a) Theta-marking exemplified by pairs consisting of a predicate and one of its arguments,
- (b) Theta-binding, exemplified by determiners or measure words and their nominals, as in 'every dog', interpreted as 'for every x such that dog(x),
- (c) Theta-identification, exemplified in simple adjectival modification, as in 'white wall' interpreted as 'white(x) and wall(x),
- (d) autonomous theta marking, where the value assigned to the open position in the theta marker is the attribute given by

7. The definition of sisterhood that I am adopting is the standard one; I am not adopting the definition proposed by Chomsky (1986b), viz., 'a and b are sisters (in the relevant sense) if they are dominated by the same lexical projections.' (1986a:13) This definition allows the VP in Chomsky's system to be a sister of the subject, although the I' node dominates VP but not the subject. This extension of sisterhood will not be necessary in the model which I will propose

its sister constituent.

(Higginbotham 1986:14)

In Higginbotham's framework, theta grids are among the information about a head which percolates to dominating nodes in the tree. Thus, since each node in a tree will bear a thematic grid, any subtree may be given an interpretation. When all of the positions in a grid have been discharged, the constituent bearing that grid is said to be saturated.

(1.10) A constituent such that every role in its associated grid is discharged is saturated.

A few simple examples will serve to illustrate how theta-discharge takes place. Recall that Higginbotham notates a discharged position by placing an asterisk or star to the right of the number (or letter, in the case of the event position) which stands for that position. In a saturated theta grid, all positions are marked with a star.

1.1.2.1 Theta-marking

Theta marking is the most straightforward case; it is simply the operation usually known as theta role assignment. In the diagrams below, I omit the specifications of the particular thematic roles assigned to the arguments, as these are not relevant to the discussion at hand.

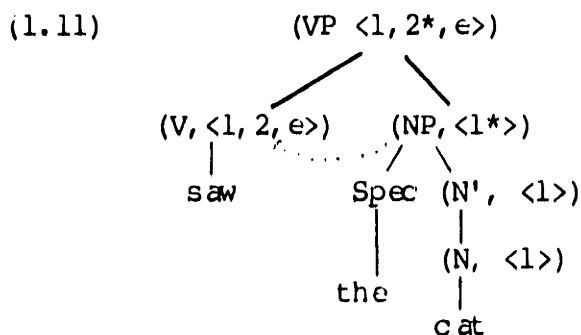

Notice that the argument is already saturated, by means of theta binding by the determiner to be discussed in the next section. The following requirement is one consequence of Higginbotham's view of the theta-criterion.

(1.12) Every argument is saturated.

We can see how this condition follows from Higginbotham's view of the theta-criterion by considering a head, X and the complement which it theta-marks, Y. Higginbotham's theta criterion states that all theta-positions must be discharged. This would of course apply to the theta positions in the grids of arguments as well as those in the grids of predicates. Since theta-discharge takes place under government, if X, a head, governs Y, then Y is unable to govern constituents external to Y, and therefore any theta positions which are not discharged within Y must remain undischarged, in violation of the theta-criterion. This is illustrated in (1.13).

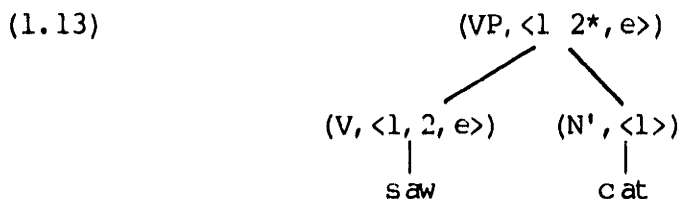

Actually, Higginbotham's claim that it follows from his system that all theta positions within an argument must be discharged; i.e., an argument must be saturated, is true only under certain assumptions about government and theta-discharge. In particular, we must either assume that theta-discharge is under strict sisterhood rather than simply government, or we must impose some sort of minimality condition

on government.⁸ Consider the structure shown in (1.14):

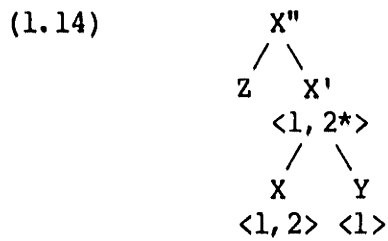

In this structure, both Z and X govern Y (and Y governs Z and X). If theta discharge takes place under government, then it ought to be possible for Z to discharge a position in the theta grid of Y, despite the fact that the theta grid of X percolates to the X' node. Thus, we would expect (1.15) to be grammatical.

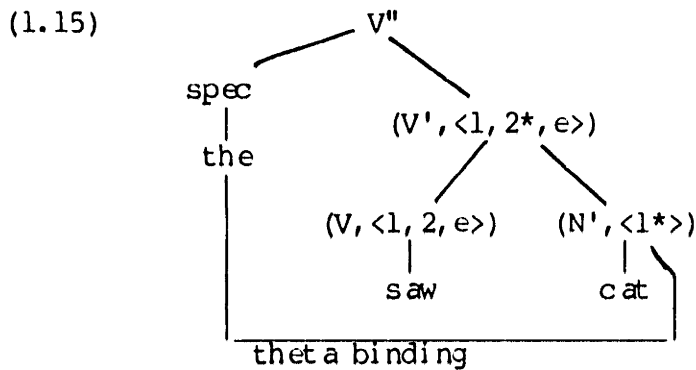

In order to rule out such a construction, we must either restrict theta discharge to strict sisterhood, as Higginbotham does in practice, or include a minimality condition in the definition of government, whereby X governs Y iff X is the closest governor of Y.

8. I thank Andy Barss for bringing this to my attention.

1.1.2.2 Theta-binding

In the diagram given above for theta binding, repeated here as (1.16), the star indicates that the position in the lexical entry of the noun has been discharged. The distinction between binding a grid position and binding a lexical item or empty category within a constituent should be emphasized. When a constituent X binds a constituent (or trace of a constituent) Y, where binding is defined in accordance with the Binding Theory (Chomsky 1981) as coindexing by a c-commanding category, then there is a coreference relation between X and Y. In fact, X is the antecedent of Y. The relation of antecedence is one which holds between two arguments.⁹ The specifier which binds the position in the theta grid of a noun, on the other hand, simply discharges that position, and thus prevents it from being further discharged.

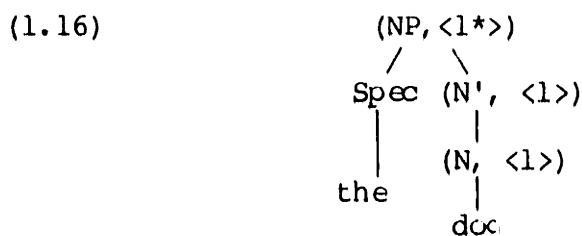

The elements which may act as theta binders include, in addition to determiners or measure words and their nominals, INFL, possibly COMP

9. Andy Barss (p.c.) points out that we may want to consider the relation which holds in Gapping, VP anaphora, etc, as cases of antecedence. If so, then the antecedence relation holds of other than arguments.

and some adverbs such as never.

1.1.2.3 Theta-identification

Higginbotham's theory of adverbial and adjectival modification is designed to capture the syntactic and semantic peculiarities of modification while avoiding the use of higher types and functionals, and consequently obviating the need for the semantic postulates which distinguish different types of modification in Montague Semantics.

The most straightforward type of modification is that exemplified by a phrase such as white house, which receives a conjoined interpretation 'white(x) and house(x)'. In Higginbotham's account of this type of modification, the position in the theta grid of the adjective is discharged by theta identification. That is, the theta position in the grid of the adjective is identified with the position in the grid of the noun. We indicate this relation by drawing a line linking the two positions. Since the positions are identified, the dominating node has one position only. Note that the position in the grid of N' is not starred, because it may be further discharged. However, one position has been discharged by theta-identifying the position in the grids of the Adjective and the noun..

(1.17)

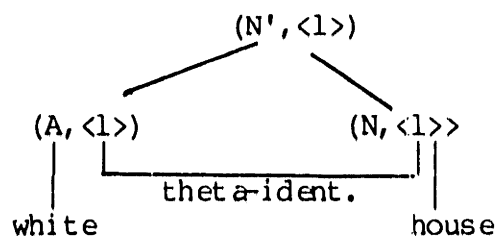

1.1.2.4 Autonomous theta marking

Many, if not most, modifications are more complex than the simple case illustrated above. In particular, the properties denoted by adjectives and adverbs are often not absolute, as in the case of color words, but are relative to the choice of attribute. For example, an expensive meal would involve paying a price which was high for a meal but low for, say, a car. Similarly, a good violinist is good for a violinist, a big butterfly is big for a butterfly, etc. This sort of relative attribution is expressed in Higginbotham's theory by the operation of autonomous theta marking.

In simple theta marking, the open position in the grid of the theta-marker takes on as its value the reference of the argument which is theta marked. In autonomous theta marking, the the open position in the theta marker takes on as its value the attribute given by its sister constituent. In the phrase big butterfly, one of the open positions in the theta grid of the adjective big takes on as its value the attribute of "butterflyness", therefore the attribution of relatively large size is not just a simple attribution, but is an attribution with respect to size for a butterfly. In the case of the adjective big, autonomous theta marking takes place in addition to theta identification. We know that theta identification takes place because we know that if x is a big y, then x is also a y.

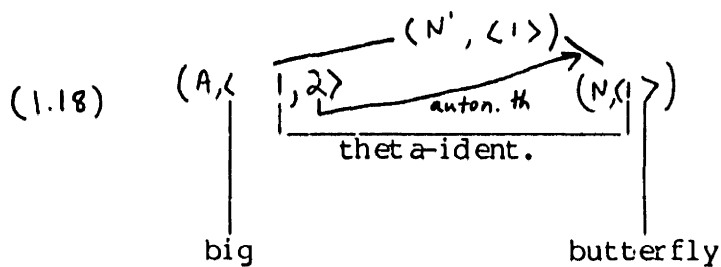

Notice that the position which was discharged through autonomous theta marking does not project to the dominating node.

The case just described was one in which the adjective discharges theta positions by both theta identification and autonomous theta marking. There are also examples which involve autonomous theta marking only. The example Higginbotham gives is the adjective alleged. Since theta identification and autonomous theta marking are independent operations, we obtain the result that an alleged x is not necessarily an x. Whereas big has one theta position which is discharged through theta-identification (hence, a big x is an x) as well as another which is discharged through autonomous theta-marking (hence, x is big for an x), alleged has only one position, and it is discharged through autonomous theta marking, hence an alleged x is alleged to be x, but is not necessarily an x.

1.1.2.5 Adverbial Modification

In his explication of the basic modes of theta-discharge, Higginbotham shows how various properties of adjectival modification can be explained. In a recent paper, Higgins (1986) has extended his theory to provide an account of adverbial modification as well.

Higgins argues that adverbs are predicates with open places, and that these places are discharged by theta identification or autonomous theta

discharge. The observed properties of adverbial modification follow from a combination of the base-generated position of the adverb, the number of arguments in the verb's theta grid, and the mode of theta-discharge employed.

The proposal that modifiers, both adverbial and adjectival, have thematic grids makes their status at D-Structure quite clear. If D-Structure is a representation of thematic relations, and if the lexical entries of adjectives and adverbs include thematic roles which must be discharged, then these thematic properties, like any others, must be represented at D-Structure.

1.2 Thematic Constituency

In what follows, I will be assuming the essentials of Higginbotham's theory as outlined above. In particular, I will be assuming that every lexical item which is a member of one of the major lexical categories has a theta grid as part of its lexical entry, and that the modes of discharge of theta positions outlined above are to be viewed as relations holding either between these theta grids or between grids and whole constituents. Holding these assumptions constant, I will argue that a particular type of abstract constituency, which I will call Thematic Constituency, can be deduced from these relations, obviating the need for X-bar conventions restricting constituency.

In Higginbotham's theory, theta grids percolate to dominating nodes

independent of syntactic category information. Percolation of syntactic category labels is supposed to be determined by X-bar theory. At first glance, this seems to be the reasonable approach since the theta grid does not always percolate from the syntactic head. In the case of theta identification, the grids of the modifier and modifyee are 'combined' and it is this combined grid which labels the dominating node. In the case of autonomous theta marking, there is a sense in which the adjective is a semantic head, at least insofar as its semantic features play a prominent role in the interpretation of the dominating node. With theta binding, sometimes the syntactic category of the bindee projects further, as is the case when a determiner binds a position in the grid of a noun, while in other cases, it is the binder whose syntactic category projects further, as when INFL binds the event position in the verbal theta grid. In the latter case, the syntactic features project from INFL, while the theta grid projects from the VP.¹⁰ (for an alternative treatment of INFL.)

(1.19)

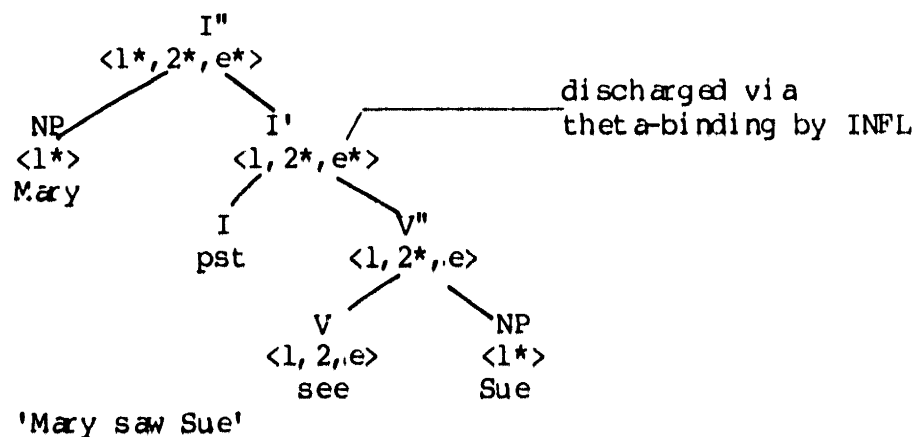

10. See Section 1.3, and Fukui and Speas (1986)

I will argue below that with a few modifications, each of which is independently motivated, it is possible to deduce thematic constituency from operations on theta grids. Thematic constituency will be shown to be universal, and not subject to either adjacency or directionality.

I take theta grids to be part of the entry of a lexical item, and thematic constituency to be a set of structural relations at the level of D-Structure. In the framework of Chomsky(1985a,b), the relationship between the lexicon and the syntactic level of D-structure is one of projection: properties of lexical items, including theta-marking properties, are projected from the lexicon into syntax, constrained by the Projection Principle and the schematic "X-bar" well-formedness conditions on phrase markers.

The Projection Principle(informal statement): lexical properties are maintained at all syntactic levels.

The X-bar Schema:

$$\begin{array}{l} \text{(i) } X' = X \quad X^{n*} \qquad \qquad \qquad \text{(order irrelevant)} \\ \text{(ii) } X'' = X^{n*} \quad X' \end{array}$$

where X^{n*} stands for zero or more occurrences of some maximal projection.

(Chomsky(1986b:3))

The theory of projection from the lexicon which I will propose here is an outgrowth of both Stowell's project of eliminating phrase structure rules and the recent research in theta theory and the structure of lexical representations, such as that done by Hale and Keyser (1985), Williams(1981a and b), Borer(1984), Travis and Williams(1983), Zubizarreta(1982), Carrier-Duncan(1985), Marantz(1984) and Higginbotham(1985, 1986). These studies have tended to converge on a set of shared conclusions:

1. There is a universal asymmetry between 'internal' and 'external' arguments of a verb.
2. This asymmetry is encoded in some way in the lexical entry of a verb. For example, Williams suggests that one of the arguments in a verb's theta grid may be designated as the verb's external argument. He indicates this in his notation by underlining the designated external argument.
3. Grammatical Relations (such as 'Subject of', 'Object of', etc.) are fully definable in terms of structural position. Chomsky(1965) defined 'Subject' as [NP,S], i.e. the NP uniquely dominated by S, and he defined 'Object' as [NP,VP], i.e. the NP uniquely dominated by VP. In Chomsky(1985) it is suggested that Subject may be defined cross-categorially as [NP, X"] while object may be defined as [NP, X'].
4. The 'meaning' of a predicate expression may be represented in the lexicon in terms of a type of definition which Hale and Keyser(1985) call the 'Lexical Conceptual Structure' of the predicate, and which Higginbotham(1986) calls the 'elucidation' of the predicate's meaning. For example, Hale and Keyser suggest that the verb 'cut' has a Lexical Conceptual Structure something like (1.20) (as paraphrased by Higginbotham(1986):

(1.20) 'cut' is a V that applies truly to situations e , involving a patient y and an agent x , who, by means of some instrument z , effects in e a linear separation in the material integrity of y .

I will be accepting these results in what follows, and will be using them plus the theory of Saturation outlined above to propose a theory of exactly how these lexical entries are related to phrase markers at D-Structure.

1.2.1 Phrase Markers

Chomsky(1955) (LSLT) postulated a level of representation P of phrase structure, which was based on a representational relation p , with p being defined as the converse of 'is a':¹¹

(1.21) $p(\text{NP}, \text{the}^{\wedge}\text{man})$ if and only if $\text{the}^{\wedge}\text{man}$ is a NP

The relation p gives a partial ordering of the strings of P, where 'strings' are steps in a derivation involving rewrite rules. The terminal strings are those strings made up of the primes in the Grammar which bear the relation p to no string. S is "the unique prime that represents every grammatical string" (1955:173).

A phrase marker, then, is a formal representation of certain relational properties of language. In all recent studies of the properties of phrase markers of which I am aware, these objects are viewed as relational structures which are representations of, in addition to category information, two separate and separable relations: hierarchical relations and linear relations. As early as 1968, McCawley and his colleagues had proposed a version of phrase structure

11. I am using the symbol '^' for concatenation.

in which domination and precedence relations were separated, and McCawley showed that such a theory could be used to account for discontinuous constituents. In the framework of Generalized Phrase Structure Grammar, Immediate domination (ID) rules are distinct from Linear Precedence(LP) rules. Other work in which domination and precedence relations are distinctly specified include Stahl(1967), Falk(1980), and Lasnik and Kupin(1977). Stowell(1981) and Travis(1984) also clearly state that the X-bar schema is unspecified for linear order. In short, most linguists would not argue that base rules must simultaneously encode both domination and precedence relations, yet the issue is still sometimes confused by the two-dimensional nature of tree representations.

1.2.1.1 Lasnik and Kupin(1977)

Lasnik and Kupin(1977) articulated a theory of phrase markers which followed Chomsky(1955) in its essentials, but which was more restrictive. In particular, it limited the structural descriptions and structural changes which could be stated for Transformational Rules. In this section, I will outline their theory of phrase markers, partly for purposes of contrast, and partly because it will become relevant later, in the discussion in Chapter 4 of Across-the-Board Representations.

Lasnik and Kupin propose the following vocabulary and definitions:

(1.22) N is the set of non-terminals

Σ is the set of terminals

- a b c ... single terminals (elements of Σ)
- ... x y z strings of terminals (elements of Σ^*)
- A B C ... single non-terminals (elements of N)
- ... X Y Z strings of non-terminals (elements of N^*)
- α, β, γ ... single symbols (elements of $\Sigma \cup N$)
- ... $\chi \psi \omega$ strings of symbols (elements of $(\Sigma \cup N)^*$)

(1.23) φ is a monostriing with respect to the sets Σ and N
 if $\varphi \in \Sigma^* \cdot N \cdot \Sigma^*$

(1.24) Let $\varphi = xAz$, $\varphi \in \mathcal{P}$, $\psi \in \mathcal{P}$

- a. y is \neq φ in \mathcal{P} if $xyz \in \mathcal{P}$
- b. φ dominates ψ in \mathcal{P} if $\psi = x\chi z$, $\chi \neq \emptyset$, $\chi \neq A$
- c. φ precedes ψ in \mathcal{P} if y is \neq φ in \mathcal{P} ,
 and $\psi = xy\chi$, $\chi \neq z$.

(1.25) \mathcal{P} is a **REDUCED PHRASE MARKER (RPM)** if
 there exist A and z such that:

$A \in \mathcal{P}$ and $z \in \mathcal{P}$, and if $(\psi, \varphi) \subseteq \mathcal{P}$,

either ψ dominates φ in \mathcal{P}
 or φ dominates ψ in \mathcal{P}
 or ψ precedes φ in \mathcal{P}
 or φ precedes ψ in \mathcal{P}

A monostriing, then, is a string which contains one non-terminal and all terminals not dominated by that non-terminal (or more accurately, all terminals not bearing the 'is \neq ' relation to the monostriing including that non-terminal). Notice that one of the restrictions imposed in this theory is that any pair of monostriings must be in

either a domination or a precedence relation. As we shall see in Chapter 4, this restriction has been called into question by Goodall(1984), who suggests that structures which show parallelism effects do not obey it.

1.2.1.2 Higginbotham(1985) and McCawley(1968)

The relations expressed by phrase markers may or may not easily be rendered as the familiar trees. Phrase markers obey certain axioms, from which various theorems can be deduced. Phrase markers represent certain types of linguistic knowledge. Some of the axioms they obey are axioms obeyed by graphs in general and others are empirical hypotheses about the language faculty.

To illustrate this point, consider the set of axioms in the formulation of Higginbotham and McCawley. They define a phrase marker as a finite set of linguistic elements, $(S, \leq, \sim\backslash)$, where

S is an underlying set of formatives and categories

\leq is the relation of DOMINATION

$\sim\backslash$ is the relation of PRECEDENCE

The DOMINATION relation (\leq), which is essentially Chomsky's relation p , obeys those axioms given in (1.26) (H's (2)):

(1.26) a. $x \leq x$

b. if $x \leq y \leq z$, then $x \leq z$

c. if $x \leq y \leq x$, then $x=y$

d. if $x \leq z$ and $y \leq z$ then $x \leq y$ or $y \leq x$ ¹²

I will discuss each of these in turn.

While Chomsky(1955) states that the relation p is irreflexive, H's axiom (1.26)a states that the domination relation is reflexive, that is, each linguistic element dominates itself. Thus, whereas Chomsky may define the terminal elements in his system as those elements which dominate nothing, Higginbotham must define the terminal elements as those elements which dominate only themselves. Note that if the domination relation is reflexive, we must be careful to exclude the case where $x \leq x$ in structure-based definitions, such as c-command.

Axiom (1.26)b states that the domination relation is transitive. Recall that the domination relation is the converse of the 'is a' relation, and the 'is a' relation is a particular type of inclusion. Inclusion is not necessarily transitive. For example, a person is included in his or her family, and a person's internal organs are included in him or her, but it does not necessarily follow that a person's internal organs are included in his or her family. Thus, the statement that phrase markers represent a transitive relation is an hypothesis about an empirical property of language, viz. that words are grouped into constituents, those constituents are further grouped, and the words are included in these 'higher' constituents.

The third axiom states that the domination relation is asymmetric.

12. or both, if $x=y=z$

In other words, the 'is a' relation and the domination relation are distinct. For example, if X dominates Y and X dominates Z, it does not follow that Y 'is a' X or that Z 'is a' X. To use a concrete example, in the P-marker below, NP dominates det, and NP dominates N, but the 'is a' relation holds between neither det and NP nor between N and NP. The 'is a' relation holds only between the {det,N} and NP.

(1.27)

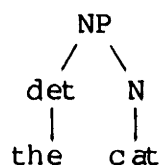

The fourth axiom states that the domination relation must be from one to several and not from several to one. In the vocabulary of trees, this constitutes the statement that no node may have multiple mothers, i.e., trees of the form (1.28) are ruled out.

(1.28)

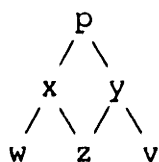

This restriction against multiple mothers provides a clear example of the way in which the theory of phrase markers proposed here serves to restrict the possible analyses of linguistic phenomena. There are numerous constructions in natural language which might quite plausibly be taken to involve multiple mothers for a single constituent, i.e., words or phrases which might be member members of two constituents simultaneously. The above axiom restricts the form of the grammar,

rendering impossible such analyses as those in (1.29).

(1.29) IMPOSSIBLE ANALYSES:

a. verbs which go only with certain prepositions:

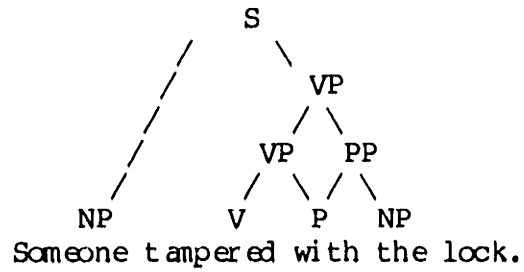

(*Someone tampered of/for/in/on/by/about the lock)

b. reanalysis:

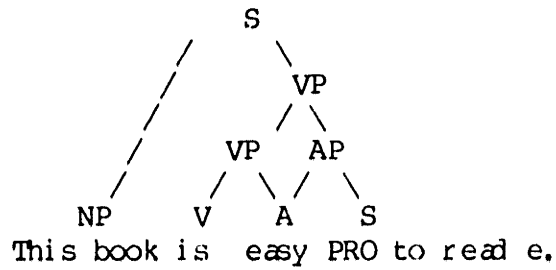

OR

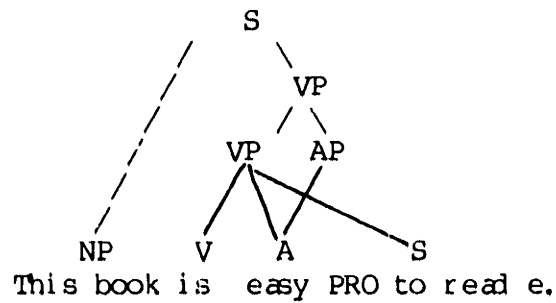

c. INFL:

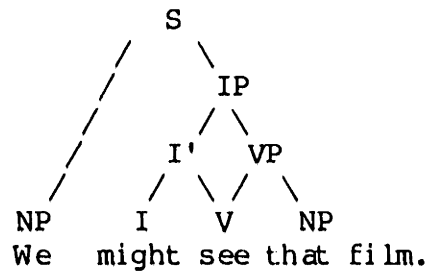

This sort of constituent analysis is ruled out by all current theories of phrase markers. Instead, the fact that these constructions have properties which suggest ambiguous constituency is treated by assigning the constructions in question an underlying constituent structure which obeys the axioms given above, and then deriving the apparently ambiguous properties by means of independent principles. If the theory of phrase markers can be restricted so as to rule out structures like those given above, and it is possible to predict the properties of sentences like these given a restricted set of grammatical principles, we have made genuine progress toward a restricted theory of linguistic principles. The importance of independent motivation for the principles which capture apparent structural ambiguities cannot be overemphasized, since a theory which is restrictive in one component at the price of vast overgeneration from another component is, as has so often been noted in the literature, not ultimately restrictive at all.

It is worth pointing out that all of the above impossible analyses are independently ruled out by X-bar theory. In fact, if it is the case that direction of headedness is cross-categorially uniform in a given language (i.e. that languages are either head-initial or

head-final), then in a theory of phrase markers which assumes 'no crossing lines', any phrase marker in which a head constituent C was itself simultaneously a member of two constituents would always be independently ruled out by X-bar theory. In order to be a member of two constituents X and Y in such a theory, C would have to be located between the members of X and the members of Y:

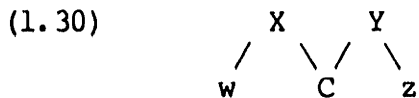

Let's suppose that the language in question is head-initial. Then C must be the head of Y, since C is initial in Y. A violation of X-bar theory results in constituent X, where C is a non-head. X-bar theory requires that all complements and specifiers be maximal projections, and if C is the head of Y, then C is not a maximal projection.

An example of a multiple mother configuration which would not be ruled out independently by X-bar theory is a 'small clause' complement, where constituent C might be the spec of Y and the complement of X, as illustrated in (31).

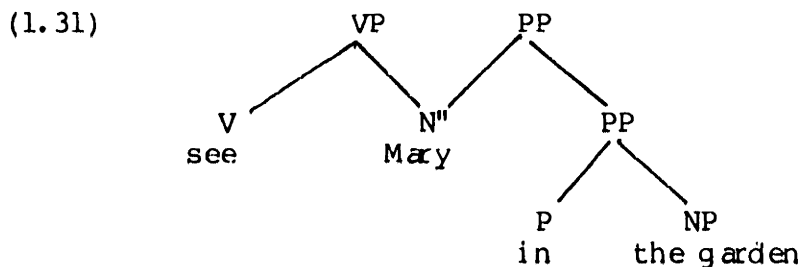

Another point to be made regarding the above axioms is that if X-bar theory and a strong form of tree pruning are assumed, as they are in many current syntactic theories, then the third axiom follows from the

fourth. This is so because if we restrict trees such that all nodes must branch, i.e. that all mothers must have multiple daughters, then the asymmetry of the domination relation follows from the prohibition against multiple mothers for a given daughter (axiom d).

Turning now to the Precedence relation, this relation is an ordering which is irreflexive, asymmetric and transitive:

- (1.32) a. if $x \sim y$, then not ($y \sim x$)
 b. if $x \sim y \sim z$, then $x \sim z$

As Higginbotham (1985) points out, the fact that the terminal elements of a string (i.e. the words and morphemes) are ordered is really a fact about articulatory phonetics.¹³ The fact that the precedence relation is irreflexive simply follows from the fact that nothing can be both precede and follow something else. Similarly, the transitivity of precedence seems to follow from the application of general laws of nature to the speech organs. Consider in this regard the statements of how precedence and domination are to be interrelated (H's (4 i and ii))

- (1.33) a. if $x \leq y$ or $y \leq x$, then not ($x \sim y$)
 b. $x \sim y$ iff for all leaves u and v
 $x \leq u$ and $y \leq v$ jointly imply $u \sim v$

13. Sagay (1986) shows that even at the level of phonetic representation, facts about articulation must inform the formalism used to encode ordering constraints. In particular, she derives the constraint against crossing lines in autosegmental mapping from facts about articulatory phonetics, within an explanatory theory of the organization of the various tiers which represent the phonetic distinctive features.

The first of these is quite general, stating that domination and precedence are mutually exclusive. The situation could not be otherwise; it is impossible for a precedence relation to hold between one object and another which contains it. Thus, the empirical hypothesis encoded here is that speech is made up of discrete objects, since precedence rather than a relation like 'beginning of' or 'end of' is the relevant relation for language.

The second statement, that x precedes y if and only if all terminal elements dominated by x precede all terminal elements preceded by y (and vice versa), rules out discontinuous constituents. That is, trees of the form (1.34a and b) are not permitted.

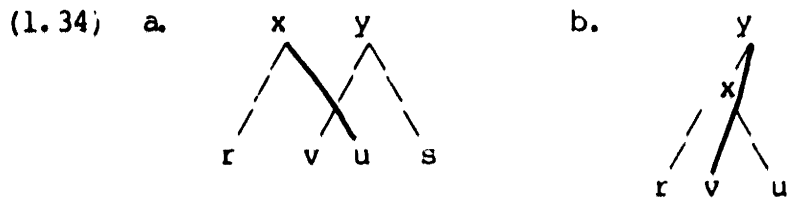

This axiom is essentially an artifact of the theory of Chomsky (1955), and loses its relevance in a theory where domination and precedence are separate and separable and are explained by independent principles. In current theory, the leaves of the phrase markers (i.e. the words) differ in status from the nonterminal elements. Furthermore, one of the independent principles responsible for the surface order of terminal and non-terminal elements is a condition on adjacency. It is the words which must be spoken in some linear order, due to the nature of the articulatory system. If a local principle, say, Case assignment, imposes an adjacency requirement on two points in a phrase marker, then they will not be able to be discontinuous.

Much recent work has been devoted to showing that the precedence relations are to be stated in terms of general principles of various subsystems of the Grammar. Stowell(1981) argued that assignment of case and theta role occurs in English only under certain strict adjacency conditions and may be specified for directionality. Travis(1984) and Koopman(1984) showed that the direction of case assignment could be independent of direction of theta role assignment, and Travis showed how these directionality parameters interacted with conditions on adjacency for case and theta role assignment to yield a restricted set of precedence relations cross-linguistically.

I would like to suggest that the domination relation and the interrelation between domination and precedence ought to be stated in terms of general principles of various subsystems of the Grammar.¹⁴

1.2.2 Headedness and Projection

First, consider the following descriptive generalizations which can be made about the operations on theta grids which were described in Section(1.1.2).

(1.35) 1. Given sisters X and Y, if X has an unsaturated theta grid and Y has a saturated theta grid, then X theta marks Y.

2. Given sisters X and Y, if X has no theta grid and Y has a theta

14. It should be noted that work in several other frameworks seems to be converging on results similar to mine. See in particular Hasegawa(1981) for a theory which combines ideas of Lexical Functional Grammar with the theory of categorial grammar developed by Brane(1980, 1981 and elsewhere. Flynn(1982, 1983) also presents a similar proposal within the framework of Montague Grammar.

grid, then X binds a position in the grid of Y.

3. Given sisters X and Y, if X and Y both have unsaturated theta grids, then X and Y are a modification relation.]

We may diagram these implications as in (1.36)

(1.36) 1. THETA MARKING:

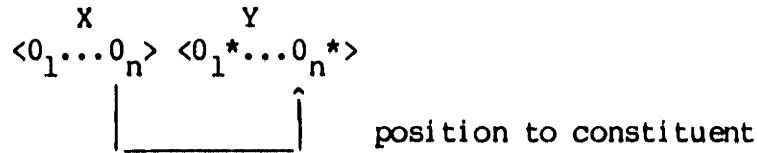

2. THETA BINDING:



3. MODIFICATION:

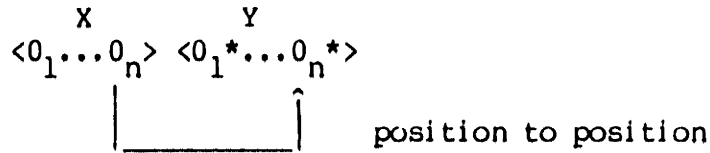

In the discussion so far, I have been rather vague about a fact which emerges quite clearly in the above diagrams: that is that the relations that we are considering may hold either between grid positions and constituents or between two separate grid positions. If we take the relations of theta marking, theta binding and modification to be asymmetric, the following paradigm emerges.

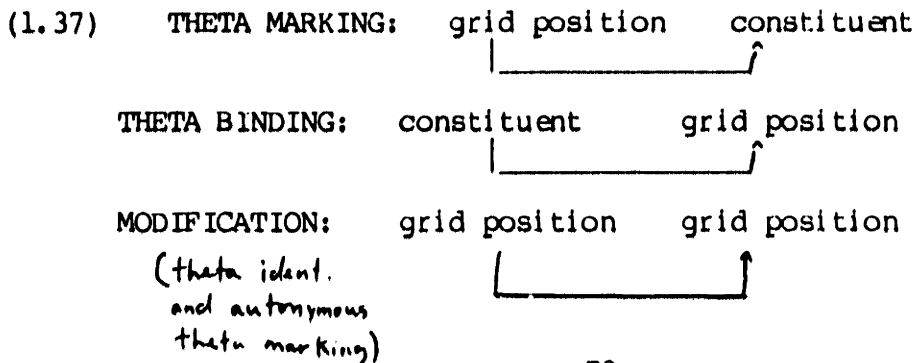

..

There is just one 'gap' in this paradigm, namely, relations holding between two constituents. But this is precisely the relation which holds in the usual cases of syntactic relations such as antecedence, c-command, etc.

The importance of this paradigm can be clarified if we consider in more detail the empirical and conceptual basis for the particular notation being used here. It might be objected that the theta grid notation is an unnecessary complication of the grammar and that allowing operations on these grids would result in vast overgeneration. However, the paradigm above gives us the insight we need to appropriately constrain operations on grids without losing descriptive or explanatory power.

In particular, we pointed out in the introduction to this work that the definition of D-Structure as a "pure" representation of theta structure was uncontroversial only insofar as it related to theta-marked arguments of a verb. Notice that in the above paradigm, the one case which involves a relation from a theta grid onto a constituent is theta marking. This introduces a clear redundancy into Higginbotham's theory. In his theory, syntactic representations are projected from the lexicon annotated with theta grids, and the relations between theta grids subsequently hold under the structural condition of government. But projection from the lexicon simply is a spellout of the grid positions which represent the verb's thematic

properties. Projection from the lexicon is essentially a matter of taking the grid positions and realizing them in syntax as a constituent. In other words, projection from the lexicon is an operation from grid positions to constituents. The fact that all and only cases of theta marking involve a relation from a theta grid onto a constituent indicates quite clearly that this relation ought not be considered additional to projection from the lexicon, but in fact, ought to be constitutive of projection from the lexicon.

To project a lexical representation is to assign it a syntactic representation. This principle is responsible for establishing the connection between the lexicon and syntax, much as the principle 'move alpha' is responsible for establishing the connection between the various syntactic levels of representation. Projection may be expressed in terms of the following rule:

(1.38) PROJECT ALPHA: Give any lexical item a syntactic representation.

'Project alpha' may be thought of as a way of effecting lexical insertion in the absence of any independently available trees into which to insert lexical items.

The following seems to hold of the system of theta discharge which we have described so far:

(1.39) x theta marks y \leftrightarrow Y is a categorial realization
of a position in the grid of X .

This is the first step in deriving syntactic structures from the properties of lexical items. Each lexical item receives a syntactic categorial representation, and there is a particular relation which

holds between a lexical item which has a theta grid and a constituent which discharges a position in that grid. The step which remains is to show how constituent structure results from the relations between theta grids. That is, we need to derive the following descriptive generalization:

(1.40) X and Y are in a theta relation \leftrightarrow X and Y are structural sisters

A theta relation is any relation holding between a theta grid and a constituent or another theta grid. In Higginbotham's theory the relationship between bearing a theta relation and structural sisterhood is a simple implication, not a biconditional. Theta relations take place under sisterhood. However, a quick perusal of the basic modes of theta discharge shows that the biconditional holds, at least at D-Structure. There are no cases where X and Y are structural sisters at D-Structure but are not in any theta relation.

We begin the explanation of how the above biconditional is derived by focussing on the case of theta marking or a complement by a head. In this case, we find that an even more striking generalization holds:

(1.41) X theta marks Y \rightarrow X and Y are sisters dominated by a projection of X

This generalization expresses a redundancy between the constraints imposed at the level of D-structure by the Projection Principle and those imposed by X-bar theory has been noticed by various linguists, including Hale(1978, 1980), Chomsky(1981), Stowell(1981), Hasegawa(1981), Marantz(1984) and Emonds(1985). As long as no empirical generalization is lost, we may wish to attribute this overlap to inherent redundancy in cognitive mechanisms. However, if there are

linguistic generalizations which are obscured by this redundancy, then it is appropriate to investigate the properties of the two systems of constraints, in order to isolate the unique properties of each, so that the observed generalizations will be expressible.

I have argued elsewhere, in collaboration with Naoki Fukui (Fukui and Speas (1986)) that there are certain important generalizations which cannot be expressed in terms of X-bar theory and the Projection Principle as they are currently conceived. We proposed a theory of well-formed D-structures which captured these generalizations. The generalizations had to do with the projection of non-lexical or "functional" categories and with certain facts about the structural analysis of Japanese. This theory is substantially elaborated and its implications are explored in detail in Fukui (1986).

Our system was based on what we took to be a fundamental asymmetry between lexical categories and functional(non-lexical) categories: functional categories project to X", and are limited to a single specifier position and a single complement position, while all projections of lexical categories are X', which is indefinitely iterable(in the sense of Harris(1951)), limited only by the Projection Principle and other independent principles of licensing. Our arguments for this distinction will be reviewed in Section(1.3.4). What is important for the present purposes is that the particular distinction made between lexical and functional categories led us to a view of D-Structure in which all arguments of a given head are realized under a projection of that head. 'External arguments' in our system become

external at S-structure for reasons of Case. The D-Structure which we proposed for a simple transitive sentence in English¹⁵ was the following:

(1.42)

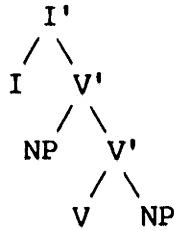

Let us assume this underlying structure and focus on the verb and its arguments to see how the existing constituent structure follows from the basic modes of theta discharge.

The positions in a thematic grid are a sub-part of a word's lexical entry. That is, they are included in the lexical entry. Taken together, the set of theta positions in a lexical entry constitute the so-called 'thematic properties' which will be given a syntactic representation at D-Structure. More precisely, as explained above, D-Structure is by definition a spell-out of these properties.

Now, under the theory that we are advocating, every lexical item has a theta grid, that is, every lexical item has thematic properties of some sort (Non-lexical categories have the property of lacking a theta grid altogether, as we shall see.). The level of representation D-Structure, then, is the level at which all of these thematic

15. We proposed that the relevant parameterization involves the presence or absence of the functional categories as fully-fledged syntactic categories.

properties are syntactically represented in a particular way, i.e. that dictated by the principles of projection and saturation.

Now we are prepared to address the question of how constituents arise from theta relations, that is, to explain why it is that if X theta marks Y then X and Y are sisters dominated by a projection of X.

Let us break this question down into its two subparts and answer them in turn. First, why is it the case that if X theta marks Y then X and Y are sisters, i.e. members of the same minimal constituent?

As soon as we abstract away from the surface precedence relations among the phonetic spell-outs of words and phrases it turns out that this is simply a non-question; it is true by definition. The fact that a theta marker and the item it theta marks are sisters follows from our conception of what a phrase marker is. A phrase marker is nothing but a set of relevant relations, and the theta-marking relation is one of the relevant relations. The definition of constituency, abstracting away from the phonetic string, is stated as the following:

(1.43) $X^{\wedge}Y$ form a CONSTITUENT iff a theta relation holds between X and Y.¹⁶

So the first part of the above question is true by definition. If X theta-marks Y, X and Y will be one of the 'constituents' in the set of relations called the phrase marker. What of the second part of the

16. Note that modification and autonomous theta making are theta relations, thus adjuncts may form a constituent with the category they modify or mark.

question: why is it the case that if X theta-marks Y, then X and Y are dominated by a projection of X, rather than of Y or of something else?

If the total lexical entry for a verb includes information about the number of arguments with which it must join in order for a well-formed clause to result, then the fact that a verb lacking an argument plus an argument forms a category whose label is essentially verb plus argument should not have to be stipulated by rewrite rules or by feature percolation rules. The label on the node which dominates a head plus its complement is deducible from the simplest arithmetic cancellation operation.

$$(1.44) \quad \begin{array}{l} \text{a)} \quad (X - Y) + Y = X - Y + Y = X \\ \text{b)} \quad (\text{verb} - \text{arg}) + \text{arg} = \text{verb} - \text{arg} + \text{arg} = \text{verb} \end{array}$$

We may notate the cancellation operation in this equation by using Higginbotham's star notation. The star indicates that the argument has been cancelled.

$$(1.45) \quad \begin{array}{l} \text{a)} \quad -Y + Y = Y^* \\ \text{b)} \quad \text{verb} - \text{arg} + \text{arg} = \text{verb}, \text{arg}^* \end{array}$$

Thus, we can deduce the formal properties of phrase markers which were previously encoded in the X-bar schema from pre-linguistic primitives.¹⁷

17. Knowledge of the arithmetic cancellation operation is prelinguistic in the sense that we know that if we have an object and then that object is taken away, we have nothing. Or conversely, if we have an object which lacks a part, and the part is added, then we have simply the object. Of course, we must learn that this concept and not some other is the relevant one for language structure, and we must be taught formalism for expressing this concept and the precise properties that the operation has with respect to numbers.

There is one more piece of information encoded in the X-bar schema which I must be careful to capture in my theory. This is the bar-level distinction. The X-bar schema distinguishes X-zeros from X-bar nodes and both of these from X", the maximal projection. X-zero but not X' or X" may undergo head-to-head movement such as that involved in INFL-to-COMP (Subject-Aux inversion) movement, which is, according to Baker (1985), an example of a very general phenomenon. X" but not X' or X-zero may move to the spec position. So it seems that at least these distinctions must be made, since these distinctions are referred to by rules of the grammar.

Higginbotham (1985) points out that we may construe the label for a lexical entry of the form shown in (1.46) as the label of a terminal point in a phrase marker.

(1.46) see, +V-N, <1, 2, e>

"Since the lexicon already contains the information that see is a verb, the point immediately dominating it is redundant." (1985:555) So when we draw a tree part of which is of the form (1.47),

(1.47) V
 |
 see

this part of the tree really comprises a single point, namely

(see, +V-N, <1, 2, e>)

If theta grids percolate up the tree along with category features, then we have a way of distinguishing X-zero from X-bar nodes: since structure is created by operations over theta grids, the X-zeros will

be all and only those points with no saturated grid positions.

I believe this view of the distinction between X-zeros and X-bars is to be preferred over the view that bar level is a primitive (on a par with, say, person, number or category features), because it can lead us toward an explanation for the cross-linguistic constraints on the rule 'move alpha'. Chomsky(1985), assuming that movement may be either a substitution or an adjunction, lists the following general properties of substitution:

- (1.48) (i) There is no movement to complement, by the Theta Criterion
- (ii) Only X-zero can move to the head position, by Emonds' Structure Preserving Hypothesis
- (iii) Only minimal and maximal projections (X-zero and X) are 'visible' for the rule Move-alpha (1985:3)

If the labels of points in a phrase marker include theta grids and structure is derived from operations on theta grids, we can maintain (i) and (ii), but we can also express (iii) without stipulation. In our theory, there would be no primitive bar level feature, rather the rules of the grammar can distinguish among the following:

- (1.49) a. points with no saturated grid positions
- b. points with fully saturated grids
- c. points with partially saturated grids.

This eliminates the X-bar principles insofar as they might be taken to be primitive innate language-specific principles. It should be emphasized that the essential generalizations captured by the X-bar schema are maintained in my theory. In fact, to a certain extent, the theory I have proposed is a particular way of interpreting the X-bar Schema as it is given in Chomsky(1985). As Rullum(1985) has pointed

out, there are various questions left open in practically every "version of X-bar theory" so far given (or, more accurately, assumed) in the literature. I have tried to address these questions in a way that would make clear that the X-bar principles are simply a statement of the structures which will result, given the inherent properties of lexical entries. No structures are generated in the absence of lexical items in this theory. The mathematical properties which linguistic structures have, such as the transitivity of the domination relation, follow from independent principles of the grammar, eg. the definition of projection of a theta grid and the theta criterion.

One important difference between the theory I am proposing and most current versions of X-bar theory is that since phrase markers are representations of abstract theta relations, and hierarchical structure is divorced from precedence, there is no reason to suppose that the domination relations obey any sort of adjacency condition as a universal requirement. Stowell(1981) and Travis(1984) have shown that adjacency requirements are language-particular and are best stated in terms of case theory, theta theory, etc. English, for example, requires a case assignee to be string-adjacent to its case assigner. However, other languages, such as Warlpiri and Hungarian do not appear to have such a requirement. In the system which I am proposing, the theta criterion is of course taken to be universal, and the basic modes of theta discharge are universal also. However, the fact that theta relations hold in English only under string adjacency is an independent fact, expressible in terms of case and theta theory.

This separation of adjacency from the principles which project structure leads us, when coupled with the requirement that all principles constraining a structural representation must be independently motivated, to conclude that if no independent rule of grammar requires adjacency of two points in a phrase marker, then they may be non-adjacent. Stowell and Travis have already illustrated cases in which modifiers or multiple non-case-marked complements within a constituent may appear in any order. However, if precedence relations are stated independently of domination relations, then there is nothing which requires that abstract theta structure be directly mappable onto the string of words. That is, we would expect to find languages in which thematic constituents will appear 'broken up' in the surface string. This topic will be taken up in detail in the next Chapter, where I will show how the theory of phrase structure which I am proposing allows a natural account of the properties which have come under the rubric "Configurationality".

1.3 Functional Categories

In this section, I will discuss how functional or 'non-lexical' categories fit into the theory that I am proposing. Many of the ideas in this section have appeared in Fukui and Speas (1986). The theory which Fukui and I proposed in that article is based on the hypothesis that there is a fundamental asymmetry between lexical categories and functional (non-lexical) categories: functional categories project to

X", and are limited to a single specifier position and a single complement position, while all projections of lexical categories are X'.

In the preceding Section, I outlined a view of projection for lexical categories in which structure was 'built up' from relations on theta grids. If structure is simply a result of theta relations, then the internal structure of a lexical category, that is, the projection of a lexical item which has a theta grid as part of its lexical entry, is limited only by the Projection Principle and other independent principles of licensing.

In English at least, the Lexical categories do not exhaustively partition the set of items in the lexicon. In particular, the items such as COMP and INFL, which have been called Non-lexical or minor Categories, act as heads but do not appear to bear the N and V features¹⁸. Since these categories are projected from the lexicon and have independent lexical entries, I will avoid the term non-lexical, and will refer to these categories as Functional Categories.

It has long been observed that the cross-category generalizations captured by the X-bar schema were fuzzy with respect to the Functional Categories, even Jackendoff (1977) resorted to some extra features to get the generalization to work out right. (Specifically, to the

18. There have been various proposals in the literature that INFL weakly bears these features in one way or another, but even these proposals have not attributed a \bar{O} grid to INFL.

features [+/- subject], [+/- object], he added [+/- comp] and [+/- det.]) Within recent GB theory, before Chomsky(1985b), it was thought that the categories IP and CP were defective in some way; Chomsky suggests extending the X-bar schema so that CP and IP would both have specifier positions. It should be noted that numerous proposals have been made by others that the X-bar schema ought to be extended IP and/or CP.

In the Fukui and Speas proposal, Functional categories have a unique specifier position, but Lexical categories may iterate "specifiers", as long as all "specifiers" are fully licensed and can be interpreted at LF. I maintain that only the specifiers of Functional categories close off projections, therefore the node dominating the maximal projection of a Functional category should be X" (or XP), while all projections of a Lexical category are X', since there is no inherent limit to their iteration.

Before proceeding, let us be clear about exactly what is meant by "specifier". Chomsky emphasizes that the notion "specifier" is strictly a relational one, used as a label for whichever maximal projections happen to appear in a given category as immediate daughters of X". However, this version of the X-bar schema does not give us an explanation for the contrast between (1.50) and (1.51).

- (1.50) a) the very very old man
 b) Mary's big red book
 c) Susan never could have been eating cabbage.
- (1.51) a) *the the old man
 b) *Yesterday's Chomsky's book.
 c) *It Mary ate a bagel.
 d) *the John's cat

e) *What who did buy?

These data show that there are some types of "specifiers" which may iterate and others which may not. Of course, it is not a priori necessary that the ungrammatical cases be ruled out by the theory of phrase structure alone. For example, some of the ungrammatical examples might be ruled out by other principles, such as the theta criterion. However, these data are important because it is routinely assumed in current theory that cases like (1.51) are ruled out by the supposed fact that there is only one available specifier position, yet X-bar theory as it is formulated in the most recent treatments provides no such restriction. Chomsky's formulation of X-bar theory allows any number of specifiers for each category.

(1.52) $X' = X''^* X$
 $X'' = X \quad X''^*$ (Chomsky 1986b:3)

It should also be pointed out that the presence of apparent subjects across categories (cf. Stowell(1982)) does not provide evidence that each category has some unique subject position given by X-bar theory, since extraction data reveals an underlying difference in the status of the "subject" from category to category, as shown by the examples below:

- (1.53) a) I saw Bill's book.
 b) I saw Bill drunk.
 c) *Whose did you see book?
 d) Who did you see drunk?
 e) Whose book did you see?
 f) *Who drunk did you see?

The subject of the adjective can be extracted (d), while the subject of the noun cannot (c). The noun plus its subject can move as a

constituent(e), while the adjective plus its subject cannot (f). These examples indicate that the status of the "subject" of the adjective drunk in (b), (d) and (f) differs in some fundamental way from the status of the "subject" of the noun book in (a), (c) and (e).

In order to avoid terminological confusion, I will henceforth use the term specifier to mean an element that closes off a category projection.

In the theory which I propose, I will be taking the position that the determiners found in NPs are Functional heads, on a par with the Functional heads COMP and INFL. To my knowledge, the first to advocate such a view of determiners was Brane(1981, 1982), who developed the idea within his own framework. (Brane called determiners 'head selectors'). Reuland(1984) proposes that NPs, in particular, gerunds, contain an INFL-like element, Szabolsci(1985) makes a similar proposal, and Abney(1986) argues within GB theory that determiners can be considered heads of a constituent Determiner Phrase (DP).

The proposal that DET, COMP and INFL¹⁹ constitute a natural class of Functional Categories allows parallel structures to be assigned to DP(=Determiner Phrase), IP and CP.

19. and preposition, in Abney's view

Fukui and Speas proposed the following structures for IP, CP and DP.

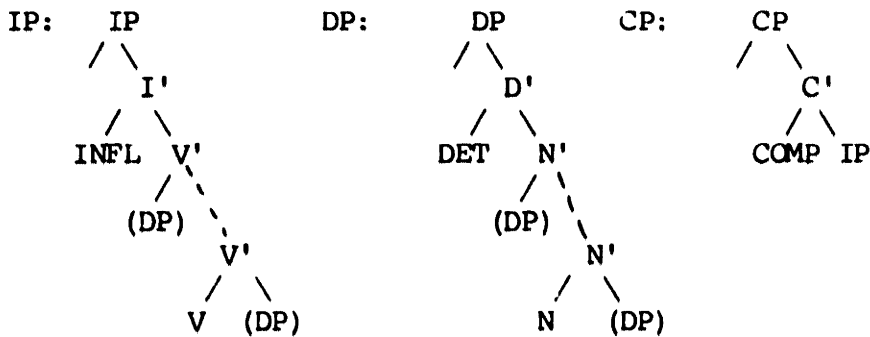

The above structures incorporates Brane's proposal that the determiner heads a constituent DP, but adapts it to a GB framework. Notice further that I am proposing that the maximal projection of a Lexical category is X'.

Notice that CP is distinguished from the other two by the fact that its complement is the projection of a Functional category. This is a property that COMP shares with the Lexical categories.

This proposal is based on a number of empirical observations about structure across categories.

1. Functional heads have one and only one (i.e. non-iterable) specifier, while the specifiers of Lexical heads may be iterable ones.
2. The specifiers of Functional heads are often (in my model, always--see below) moved from within their complement.
3. All Functional heads have specifier positions; it is not at all clear that all Lexical heads have spec positions.

4. Languages which lack Functional heads also lack specifier positions.
5. Functional heads are special in that they are closed-class items.
6. Functional heads lack the sort of semantic value associated with Lexical categories.
7. Functional heads always select a unique complement.²⁰

The claim that Lexical categories project to X' while Functional categories can project to X'' is substantiated by data from Japanese. Japanese lacks the Functional categories DET, INFL and COMP,²¹ so this theory of projection makes the prediction that all Japanese constituents are X' and not X''. Below I will give evidence involving NP structure, pro-forms, subjects and scrambling that the prediction is correct; Japanese phrases should be considered X' projections, because they do not contain the position which would close off a projection, yielding X'' categories. For a more detailed discussion of evidence that Japanese phrases also behave as X' and not XP with respect to extraction, see Fukui (1986).

20. These last three were pointed out by Abney(1986).

21. The absence of DET in Japanese is obvious. It is argued in Whitman(1984) that INFL should be regarded as a verbal complex, rather than as an independent syntactic unit. Fukui(1986) argues that what have traditionally been regarded as complementizers (eg. to 'that', ka 'Q', etc.) should not be considered to be a single Functional category COMP, but should instead be analyzed as a postposition (to), a noun (ka), etc. See Fukui(1986) for details.

1.3.1 The Structure of IP and DP

The projection principle allows any number of arguments (and modifiers) to project, as long as they are all fully licensed and can be interpreted at LF. The X-bar schema, on the other hand, restricts the projections of Functional categories to one specifier and one complement. This move captures the fact mentioned above that Functional categories differ from Lexical categories in that they take unique complements. Further, it allows us to encode the distinction between iterable and non-iterable specifiers: the elements in Lexical categories which are neither heads nor complements are iterable if they meet all licensing conditions of other modules of the Grammar, while Functional categories have a unique specifier.

1.3.2 Function Features

I adopt the standard analysis of the elements of the category INFL: i.e. that tense/agr assigns nominative Case, while to does not. I further extend this analysis, proposing that each Functional category includes some elements which assign what we will call Function Features, or F-Features, and other elements which do not assign these features. F-Features include nominative Case, assigned by tense/agr, genitive Case, assigned by 's, and #WH, assigned by a WH-COMP (for the latter two cases, see below). We now introduce the term Case to mean both Case in the standard sense (i.e., Case assigned by Lexical Categories, in particular Objective Case assigned by V) and F-Features

assigned by Functional Categories. The spec position of a Functional category can appear only when Case is assigned to that position. Otherwise, the projection of a Functional category stops at the single-bar level. The Case assignment which licenses the element in spec position may come either from the Functional head itself (this would be licensing by F-Features), or, as in Exceptional Case Marking environments, from a Lexical element (this would be licensing by Case assignment).

In DET position, articles are in complementary distribution with 's, the genitive Case assigner. Therefore, we will suppose that 's, like tensed INFL, assigns Case, and that the, a, etc., like to, do not assign Case. The only possible filler for the spec of COMP is a WH-word, so I suggest that the feature [+WH] be considered an F-Feature, a member of the set of Case, so that the alternation between +WH and that in COMP is parallel to the tense/to alternation in INFL and the article/genitive alternation in DET. This gives us the following paradigm:

	<u>CP</u>	<u>IP</u>	<u>DP</u>
Case assigner	WH	tns/agr	's
non-Case assigner	that	to	the

We now have a way of explaining the doubly-filled COMP effect, which, as Abney (1985) points out, seems to be parallel to the fact that articles do not appear with other specifiers. The reason that (1.54) a-c are all ungrammatical is that the Functional heads underlined in

these examples do not have F-Features to assign, so the pre-head position is unlicensed.

- (1.54) a) *I wonder who that arrived.
b) *I think that Susan to leave.
c) *I enjoyed Mary the book.²²

By associating the presence of an element in the spec of a Functional category with the presence of Case, I am disassociating totally the existence of specifiers from the Projection Principle. This means that the "Extended" part of the Extended Projection Principle really has nothing to do with the Projection Principle, if the former is interpreted as a requirement that IP have a spec position. I differ, then, from Rothstein(1983), who suggests that the requirement that the spec of IP be filled (in English) can be explained in terms of a general requirement that predicates must be predicated of something and thus must have subjects. In this view, this condition on predication may be true, but since saturation of a predicate takes place within the projection of a Lexical head, the condition on predication has nothing directly to do with the licensing of the spec of IP position. The requirement that I adopt, which is also independently necessary in Rothstein's theory, is the following:

THE SATURATION PRINCIPLE: All positions in a grid must be discharged.

The Saturation Principle is a simple extension of Higginbotham's

22. The verb enjoy cannot Case-mark Mary, presumably because it has only one Case to assign, and that Case goes to the DP as a whole.

version of the theta criterion, repeated as (1.55).

(1.55) THETA CRITERION:

- a) Every thematic position is discharged.
- b) If X discharges a thematic role in Y, then it discharges only one.

(Higginbotham 1985:561)

For the purposes of the Saturation Principle, "grids" include not only the theta grid of a lexical entry, but also Kase grids (F-Features and Case). When all positions in a given grid are discharged, that grid is saturated. Thus, the Saturation Principle collapses the Theta Criterion with a requirement that if an element has a Kase to discharge, the feature must be discharged.

As I have stated previously, Functional heads do not have theta grids, while Lexical heads do have theta grids. Both may have Kase grids. Notice that the assumption that lexical items have Case grids is not an innovation; in fact it is implicit in most theories of lexical representation and explicit in most studies of languages with richer overt case marking than English. (In such work, what I am calling a "Case grid" is usually called a "case array".) See, for example, Ostler (1979) Levin (1983) Nash (1980) and Simpson (1983). See also Fukui (1986) for some evidence that Japanese verbs must have Case grids which are, although related, independent of their theta grids.

A slight modification to Higginbotham's statement of the Theta Criterion gives us the appropriate, more general Saturation Principle:

(1.56) SATURATION PRINCIPLE

- a) Every position in a grid is discharged.
- b) If X discharges a position in a grid of Y, then it discharges only one.

1.3.3 Deriving the Surface Order

In the proposed underlying structures, all arguments of the verb appear under a projection of the verb. There are several ways that I might derive the surface order of English from these D-structures. Following Fukui and Speas, I suggest adopting the standard assumption that nominative and genitive *a* are assigned leftward, so one of the categories under V'/N' must move to get Case. This property of assigning Case leftward extends to all Functional categories in English, and is one of the properties which distinguish Functional categories from Lexical ones. Under such an analysis, a movement operation parallel to that in the standard Raising cases takes place in ordinary tensed sentences.²³

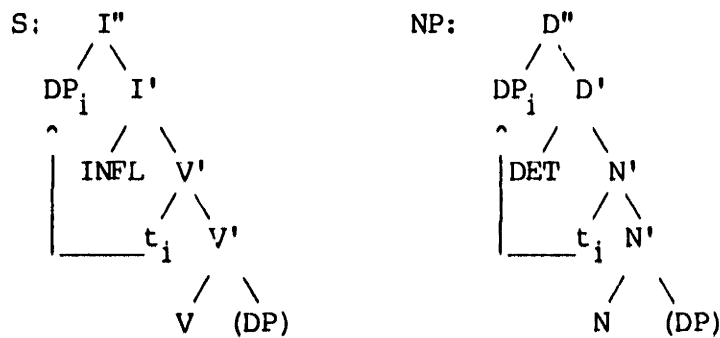

23. The spirit of this "subject raising" in the clausal case can be traced back to Fillmore's(1968) "subjectivalization" rule in the framework of Case Grammar, and McCawley's(1970) proposal that English is underlyingly VSO. Within the GB framework, similar proposals have been made by various people. Lumsden(1985) has suggested that the subject of a clause should be considered an A' position. Koopman and Sportiche(1985, 1986), Kuroda(1985) and Johnson(1985) have independently proposed subject-raising analyses, but in orientations quite different from ours. See Koopman and Sportiche(1986) for some arguments for the "subject raising."

An interesting difference between S and NP is captured under this analysis: since the verb may assign structural Kase (recall that in my theory, Kase includes Case as well as F-Features) to its sister the Direct Object, only the subject may raise to get Kase from INFL, since the movement of the object to a Kase-marked position results in a violation of (some) condition on chains which would rule out Case (and Kase) conflict (Chomsky(1985b)). Nouns, on the other hand, do not assign structural Case, according to Chomsky(1985b), therefore either argument may move, and the other argument will be Kase-marked by an inserted preposition.

- (1.57) a) [_{DP} the Roman_i [_D's [_N t_i destruction of the city]]]
 b) [_{DP} the city_j [_D's [_N destruction t_i by the Romans]]]

Furthermore, in our system any DP may move to receive the Kase assigned by D, regardless of whether that DP is an argument of N.

- (1.58) a) The city's destruction by the Romans
 b) The Roman's destruction of the city
 c) Yesterday's destruction of the city by Romans.²⁴

Under this system, the subject of a clause is required in spec of IP position only by the Saturation Principle. If INFL has F-features to discharge, some DP must move to the sister of I' position so that those features may be discharged. Exceptional Case Marking verbs can also be explained in terms of the Saturation Principle. An ECM verb has

24. See Anderson(1984) and Larson(1985) for suggested accounts of the apparent caselessness of certain NP adverbs in phrases like 'the destruction of the city yesterday'.

accusative Kase to discharge, so the argument of a subordinate verb which does not otherwise get Kase is moved into a position where it may get that accusative Kase. Notice that another difference between Lexical and Functional heads is that Lexical heads may govern and Kase-mark into their complements, while a Functional head may not. This difference may be attributable to the directionality of F-feature assignment: the direction of F-feature assignment (at least in English) is uniformly to the left.

An alternative possibility for deriving the correct order of the subject and predicate at PF (suggested to me by Noam Chomsky (p.c.)) would be to assume that there is a rule of PF which fronts the subject, and that INFL is allowed to assign Kase rightward to the subject within V'. One advantage of this approach is that Case assignment (in the standard sense) may be considered to be uniformly rightward, under government defined in terms of "c-command" rather than m-command (see below for definitions of these notions). Disadvantages include the following:

- We must assume an equivalent PF rule within NP, which may only apply if the DET is the genitive Kase marker.
- We must stipulate that the PF rule must apply to one and only one constituent.
- We must extrinsically order the "subject-fronting" rule to apply

before wanna-contraction,²⁵ in order to block derivations such as (1.59).

(1.59) Mary might want [_{CP} [_{C'} [_{IP} [_{I'} to [_{V'} Sue win]]]]]--->

*Mary might wanna Sue win.

1.3.4 The Spec Position

In this proposal as well as in the other proposals involving some "subject raising" operation in simple transitive sentences, it seems to be the case that the position into which the subject is moved is an A' position, with the result that all traces are A'-bound traces. I might stipulate that the spec of I' and the spec of D' are A-positions, since elements with argumental status may appear in these positions, but such a stipulation would obscure the fact that these positions are always empty at D-structure. In this theory, the crucial distinction is between theta positions and non-theta positions, and A-positions are equivalent to theta positions.

It is not a straightforward matter to conclude that all traces are A' bound. For one thing, movement of an NP does not show cross-over effects in sentences like (1.60a), as contrasted with (1.60b), in which an operator has moved.

(1.60) a) John_i seems to his_i friends to be t_i intelligent.

b) *Who_i does it seem to his_i friends that Sue likes t_i?

25. See Fukui (1986) for a more detailed account of wanna-contraction under this system.

If I am right that all movement is to an A' position, this will necessitate that I adopt a theory of chains in which the content of the head rather than the position of the head is what distinguishes different types of chains. A variable might be defined in such a theory as an element that is Operator-bound (and perhaps Case-marked). Thus, the A/A' distinction would have no real content.

The result that all movement is to an A'-position is complemented by several recent proposals. Kayne(class lectures, MIT) and Barss(forthcoming) give evidence that the content of the head of the chain rather than the position of the head is the relevant factor in defining empty categories. Also, Saxon(1986) and Bergvall(1986) argue that some languages have a base-generated reflexive empty category, i.e. an anaphoric empty category which is distinct from NP-trace. Saxon investigates the consequences of the existence of this element, proposing that traces are contextually defined while other empty elements possess inherent features. In her system, as in ours, it seems to be the case that the only property distinguishing WH-trace from NP-trace is the content of their antecedent.

We may ask at this point why it should be the case that the Functional categories have one and only one spec position. Why not two, five, any odd number etc.? While this answer to this question at this point can be little more than speculation, we can make some observations. As I pointed out above, the only elements which seem to appear in the unique spec position of a Functional category are elements which have moved into the position at S-structure. This

suggests that the landing site might actually be an adjunction site, and the fact that a barrier is formed when an element moves to receive F-features may be a subcase of the more general constraint on non-structure-preserving movement known as the Freezing Principle, which states (at this point in our theoretical knowledge, stipulates) that when one element is adjoined to another, the structure is "frozen", i.e., no further movement may take place out of it. The view that all movements are adjunctions has a vast number of consequences which I am not prepared to address at this point,²⁶ so for the moment, I will refer to the spec of a Functional category as a position which is optionally present, and leave open the question of how exactly to distinguish adjunction from substitution to an optional position. The core of this proposal is that positions at D-structure must be licensed by independent principles of Universal Grammar; no positions are licensed by well-formedness conditions on phrase markers.

In part, the ultimate answer to the question of why there can be one and only one spec for Functional categories may parallel Chomsky's (1985b) answer to a similar question about bounding nodes for subjacency: If I assume that Universal Grammar contains no counting mechanisms, then I might expect that the Functional categories, whose

26. In particular, it is generally assumed that the node created by Chomsky-adjunction is identical in both category and bar level to the category adjoined to. The node which dominates the spec of a Functional category, on the other hand, is a higher bar-level than the sister of the spec.

purpose, intuitively, is to connect parts of the sentence,²⁷ would appear in construction with only two constituents of the sentence in any given structure, hence its unique spec (and unique complement).

1.3.5 Some Consequences of the Proposal

In the theory that I am proposing, Λ -positions are equivalent to theta-positions, and all theta-positions appear at D-structure inside of X' . Consequently, the position of spec of IP is a theta-bar, and hence an Λ -bar, position. I believe that there is evidence that this is correct, as I will outline below.

Furthermore, projection from X' to X'' is licensed only if Case is discharged to the spec of X' . Hence, the projection of a Functional category is X'' iff an element in its spec receives Case. One result of this is that the only "truly empty" positions at D-structure are those licensed by Case principles.²⁸ In fact, the spec of a Functional category is always empty at D-structure. I take this to be due to the fact that assignment of Case takes place at S-structure, while theta assignment takes place at D-structure.

27. This intuition is behind the proposal for the representation of Aux elements made by Oehrle (in Steele et. al (1981)), and seems also to be found in the work of Ross (1967), McCawley (1970), Kayne (1983) and Emonds (1985).

28. I am assuming that there exist phonetically null lexical items, and that traces count as "filling" a given position.

1.3.5.1 Adverbs as spec of N'

If PRO is within X', then I can also correctly predict the following contrast: (See Yamada(1983) and Chomsky(1985a) for arguments that PRO should be optionally present within a noun phrase in order to account for various binding facts. cf. also Williams (1985) for some counter arguments.)

- (1.61) a) The men read the stories about them.
 b) The men read the stories about each other.
 c) The men read Mary's stories about them.
 d) *The men read Mary's stories about each other.
 e) (?)The men read yesterday's stories about each other.

If I assume that the noun stories has one and only one theta-role (specifically, the external-theta role) to assign, then (d) cannot contain a PRO within the N', while (b) and (e) may contain PRO.

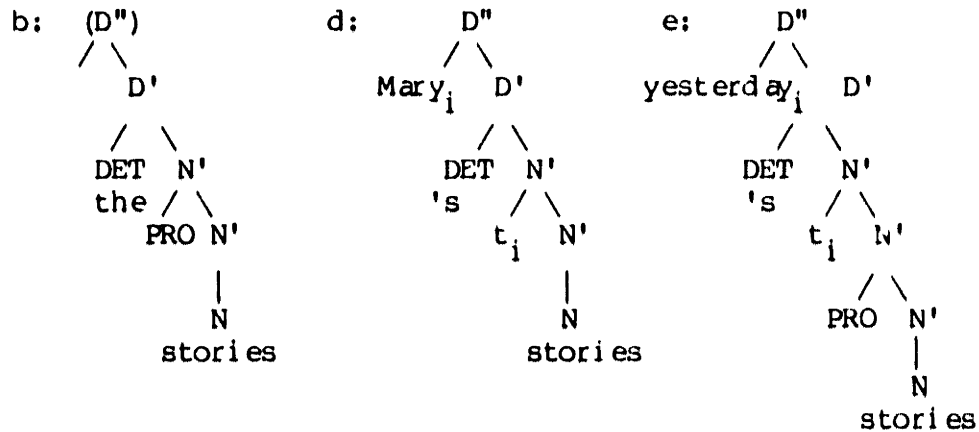

The reason that (1.61d) is ungrammatical is that, as shown above, since stories has only one external theta-role to assign, and that theta-role has been assigned to Mary, there can be no PRO within N'. Therefore,

there is no antecedent for the anaphor within the DP.²⁹

1.3.5.2 Small Clauses

It may be possible within this system to give an account of small clauses as maximal projections of X', as shown in (1.62).

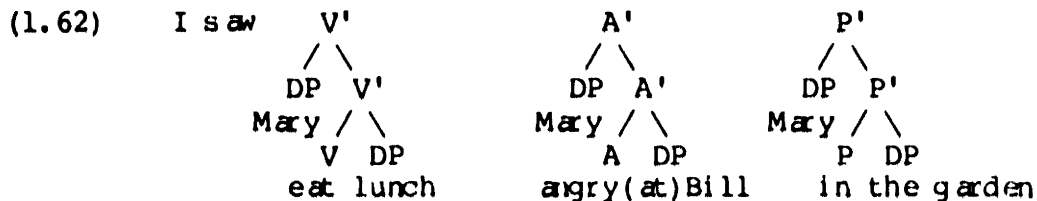

This analysis is not completely straightforward. For one thing, small clauses involving predicate nominals apparently cannot be considered projections of X' (this was pointed out to me by Ken Hale)

- (1.63) a) I made Mary the chief.
 b) I consider Mary the best student.
 c) I appointed John Mary's assistant.

If these examples are fully grammatical, then this constitutes evidence that both the subject and the predicate in a small clause are some sort of maximal projection.

A further issue which must be ironed out is that in the case of a verbal small clause, I must distinguish two different projections of

 29. Somehow I need to insure that N projects to N', so that it is not a sister to the "external" argument. This problem crops up again in the treatment of intransitive sentences.

V':

(1.64)

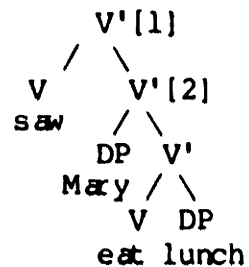

If small clauses are to be a maximal projection of X', then we must be sure that the definition of "maximal projection" can distinguish between V'[1] and V'[2] above. I suggest that this distinction be made in terms of the theta grid labelling each node. In the theory of projection which I am advocating, V'[1] in the above diagram will have an unsaturated theta grid, while V'[2] will have a saturated theta grid.

The view of phrase structure allows us to suggest a revision to Chomsky's (1985b) definition of "barrier" which has various advantages over the original version. This revision and its consequences are outlined in detail in Fukui (1986), but I will review them briefly here so that the implications of the present proposal will be clear.

As outlined in the sections above, I suggest that syntactic positions must be licensed by some independent module of the Grammar; no positions are licensed by well-formedness conditions on phrase markers. Double-bar level projections are created only when some element moves into a position to which Case is discharged. We have proposed the following general principle:

- (1.65) THE SATURATION PRINCIPLE: a) Every grid position is discharged.
b) If X discharges a grid position in Y, then it discharges only one.

As a direct consequence of the Saturation Principle and the hypothesis that no positions in syntactic structure are licensed by well-formedness conditions on phrase-markers, I have the following condition on the projection of Functional categories:

- (1.66) FUNCTIONAL PROJECTION THEOREM:
A Functional head projects to the X" level iff there is Kase to be discharged to its spec position. Otherwise, it projects only to X'.

In this theory, the spec position exists only if some Kase Features are discharged onto an element in that position. As we will show below, the Functional Projection Theorem leads to a reformulation of the definition of "barrier" which avoids the stipulation that IP does not count as a barrier.

The crucial assumptions of this theory which bear on the definition of barrierhood are these:

1. Only X" can be a blocking category.
2. Lexical heads project only to X'.
3. Functional heads project to X" iff some Kase must be discharged to an element in their spec position. Otherwise they project only to X' (Functional Projection Theorem)

The definition of a barrier proposed by Chomsky (1986b) was given in

Section 1.1.2, and is repeated here as (67).

a is a Blocking Category(BC) for b iff a is not L-marked and a dominates b.

a is a barrier for b iff (i) or (ii):

(i) a immediately dominates s, s a BC for b

(ii) a is a BC for b, a not equal to IP.

Chomsky(1985b:11-12)

L-marking is defined as direct theta-marking by a Lexical head.

The proposal of Fukui and Speas allowed us to suggest revising the definition of "barrier" along the following lines:

(1.67) 1. a is a BC for b iff

(i) a dominates b

(ii) a = X"

(iii) a is not L-marked and

(iv) a does not m-command the antecedent of b

2. a is a BARRIER for b iff (i) or (ii)

(i) a is a BC for b

(ii) a immediately dominates a BC for b.

We adopted the definitions of m-command, c-command and dominance given by Chomsky:

C-COMMAND

A c-commands B iff A does not dominate B and every G that dominates A dominates B.

M-COMMAND

A M-commands B iff A does not dominate B and every G, G a maximal projection, that dominates A dominates B.

DOMINANCE

A is dominated by G only if it is dominated by every segment³⁰

30. The notion of segment is not formalized by Chomsky, but descriptively, given a structure of the form $a [_{XP} [_{XP} \dots b \dots]]$, where

of G.

GOVERNMENT

A governs B iff A M-commands B and every barrier for B dominates A.

In the Fukui and Speas model, there is a distinction between "maximal" projection of G in the sense of the highest occurring token of G, and "maximal" in the sense of XP(X"). This proposal therefore predicts that different principles and rules of the Grammar might refer to different types of maximality. Henceforth, when I mean to refer to X", I will refer to X", and I define "maximal projection" as follows:

\underline{a}^n is the MAXIMAL PROJECTION of \underline{a} iff
it is immediately dominated by \underline{b}^m , where
 $a \neq b$

Since I am assuming that theta grids are included in the phrase marker, it is clear that a and b will be equivalent only if a and b have the "same" theta grid. Theta grid G and theta grid G' are "the same" if G and G' are rooted in the same lexical item.

So far, I have been referring to "languages which lack Functional categories", but there is no a priori reason that a language must have all or none of the Functional categories. Japanese and English seem to represent the extremes in this regard.

It should also be pointed out that while I have related the surface word order in English to an interaction between Case theory (Case theory, in my terms) and the presence of Functional categories, the two

there are two occurrences of the same category, each occurrence is considered a segment.

modules are probably distinct. We would expect, then, to find languages which have Functional categories, but which realize Case (and perhaps also F-features) by means of overt case markers. The surface effect of such a system would be that any constituent could move into the position of spec of the Functional category. While this speculation is vastly oversimplified, the system I have proposed may lead to a new analysis of general Aux-second phenomena.

For example, consider a language which is like English in that it has the Functional category INFL, but INFL does not assign nominative case, Case being assigned inherently and realized by means of case morphemes. In such a language, there might be some independent motivation for movement to the spec of this Functional category, for example, for purposes of focus.³¹ If movement to the spec of INFL is not related to Nominative Case, then we would expect that such movement would not be limited to DPs, but that any XP could move. Thus, the Functional Category INFL would show up in second position.

1.4 The X-bar schema

It should be emphasized that although I am eliminating certain aspects of some versions of X-bar Theory, I am not sacrificing the ability to express the cross-categorical generalizations which were the

31. Focus may also be a Case feature.

original motivation for the X-bar Theory. In this section, I will show that in fact, I am moving closer to capturing the true nature of what is general about the structure of syntactic categories.

Two core aspects of X-bar theory remain in this proposal. First and foremost, I retain a conception of syntactic structure as projected from lexical items; thus, the arbitrary structures like those in (1.68) which were in principle generable by Phrase Structure rules cannot arise.



Secondly, I take the head-complement relation and the modifier-modifiee relation to hold within any category. Since theta-role assignment must take place under sisterhood, and modifiers may iterate, the internal structure of the categories turns out to be quite similar.

According to Stowell(1981), the X-bar schema imposes the following well-formedness constraints (which McCawley(1978) called "node admissibility conditions") on D-Structure representations:

1. Every phrase is endocentric.
2. Specifiers appear at the X'' level; subcategorized complements appear within X'.
3. The head always appears adjacent to one boundary of X'.
4. The head term is one bar-level lower than the immediately

dominating phrasal node.

5. Only maximal projections may appear as non-head terms within a phrase. (Stowell(1981:))

As Stowell points out, the version of X-bar theory which he articulates captures all of the above conditions, but it is not a priori necessary that these conditions should be captured by a single schema, nor is it trivially obvious that all five conditions are empirically accurate. Pullum(1985) points out that the correctness of the claims made by Stowell's version of X-bar theory have not been seriously investigated, and suggests various modifications.³² Let us take a closer look, then, at each of Stowell's conditions.

- 1) The hypothesis that every phrase is endocentric seeks to formalize a generalization which is intuitively compelling but not obviously

32. Pullum suggests that the conditions encoded in Stowell's X-bar schema can be more accurately reworded as in (i).

- LEXICALITY: Every nonterminal is a projection of some lexical[i.e. major or minor] category.
- SUCCESSION: The bar level of a head is one less than the bar level of its mother.
- UNIFORMITY: The maximum permitted bar level is the same for every lexical category.
- MAXIMALITY: Non-heads in a rule are either maximal projections or minor lexical categories[i.e. those with a subcat value but no bar value].
- CENTRALITY: The initial symbol is the maximal projection of some (lexical) category.[major or minor]
- OPTIONALITY: Every non-head daughter in a rule is optional.

He argues against the uniformity and succession conditions, concluding that the correct condition is one which says that the bar value of a head is the same as that of its mother unless a rule or constraint determines otherwise.

true. In the case of the categories NP and VP, the fact that sometimes a single terminal element can be substituted for the phrasal category, as shown in (1.69), provides a clear motivation for positing that one terminal element in the phrase bears category features identical to those of the phrase itself, i.e., that the phrase is endocentric.

- (1.69) a. [_{NP}The huge beavers on the pond] are building dams.
 b. [_{NP}Beavers] are building dams.
 c. Mary [_{VP} quickly ate a sandwich.]
 d. Mary [_{VP} ate.]

Other categories are not so clear. For example, the substitution test gives ambiguous results when applied to PPs. In (1.70) a-c, the NP Tuesday but not the preposition on can be substituted for the PP on Tuesday, while in d-f, the preposition around but not the NP the yard can be substituted for the PP around the yard. The well-formedness of the substitution in these cases appears to depend more on semantic factors than on syntactic ones. Thus, we have no clear way to tell whether a P+NP constituent is headed by the preposition or not.

- (1.70) a. Kathy arrived on Tuesday.
 b. Kathy arrived Tuesday.
 c. *Kathy arrived on.
 d. The children ran around the yard.
 e. The children ran around.
 f. *The children ran the yard.

Other possibly exocentric phrasal categories include Sentences, which Williams (1983) argues are to be distinguished from NPs by the fact that the former are exocentric while the latter are headed, gerunds, which Williams analyzes as non-headed, base-generated topic+S constructions like those in Chinese and Japanese, and quantifier phrases (all of the

students, every book), which seem to be ambiguously NP's and QP's (see Selkirk (1977) and Bresnan(19)) It should be emphasized that these authors have suggested that some phrases might be exocentric, but all of them agree that most phrases have heads. The relation between the category of a lexical item and the category of a phrase in which it appears with its subcategorized complements is clearly one of identity (except for bar level). Stowell's condition, then, can be more accurately rephrased as a "bottom-up" condition instead of a "top-down" condition:

(1.71) All lexical items head a syntactic projection.

2) As Rothstein (1984) points out, the fact that subcategorized complements appear within X' can be easily derived from the lexical restrictions on complement selection. This part of the X' schema expresses the requirement that complements must be sisters of the head which selects them. We expect this fact to follow from the nature of projection from the lexicon, in which case no syntactic well-formedness condition would be needed.

Non-theta-marked elements such as adverbials can apparently appear at either the X' or the X" level. Thus, modifiers and secondary predicates may be either specifiers or complements.

3) The observation that the head always appears adjacent to one boundary of X' is extremely interesting if our theory of syntax allows 'flat', non-binary branching structures. If only binary branching is allowed, then X' has only 2 boundaries anyway, so it would be logically impossible for the head to fail to be at a boundary of X' Still, the

observation would remain that we do not seem to find languages with, for example, ditransitive verbs where the verb is in between its 2 arguments.³³ If Stowell's observation is true, and if binary branching does not render it vacuous, then it would most likely follow from the parameter which determines directionality of headedness (whether this parameter were stated explicitly in terms of headedness, as in Huang(1981) or in terms of directionality of theta assignment, case assignment and predication, as in Travis(1984) and Koopman (1984))

4) Arguments against the condition that the head term of a structure is one bar-level lower than the immediately dominating phrasal node have appeared recently in work by Pullum(1985), Stuurman(1985), Travis (1984) and Fabb(1984). Pullum, who calls this condition the condition of Succession, proposes that the correct condition is one which says that the bar value of a head is the same as that of its mother unless a rule or constraint determines otherwise. Stuurman proposes a system in which succession does not necessarily hold. Both Travis and Fabb propose systems in which intermediate bar levels are all the same, and rules may only refer to XP or X-zero. Their proposals are embedded within theories in which the inter-category distributional facts (expressed by, for example, Jackendoff, must be explained by independent

33. It is interesting to note that clitics do set up a structure where the verb is between 2 objects in the surface string, as in the following French example:

- (1) Je lui donne un cadeau.
I him give a gift.
'I give him a gift'

principles, such as a requirement of adjacency for case assignment and a c-command requirement for scope.

5) The statement that only maximal projections may appear as non-head terms within a phrase depends upon a stipulation that determiners, intensifiers, (auxiliary verbs?), and other specifiers are maximal projections. Also, it is not entirely clear that adjectives are maximal projections. Adjectives have no required determiner, so it is not clear how we would test whether they project to an XP projection. The fact that Adjectives do not project their category features, i.e., that N is the head of an A-N configuration, is not really evidence that adjectives project to AP if it is true that all structures are endocentric.

As Pullum points out, another constraint encoded in the X-bar schema as formalized by Stowell is one which Pullum calls Uniformity:

UNIFORMITY: The maximum permitted bar level is the same for every lexical category.

It has never been clear that uniformity captured a correct generalization. Those who have argued against uniformity include George(1980), di Scullo(1980), Williams(1981), Muysken(1982), Stuurman(1985) and Emonds(1986). If one adopts the assumptions of George, Travis and Fabb, that all nodes are X, X', or XP, then the uniformity condition becomes trivial. If there may be indefinite iteration at the level of X', and the label on the maximal projection does not 'count' bars but is simply distinguished by definition from an intermediate projection, then the notion of 'maximum permitted bar

level' is meaningless. The Fukui and Speas (1986) model of projection, disputed the hypothesis that all maximal projections are identical with respect to the number of bars, suggesting instead that Functional or Non-lexical categories which are closed off by a specifier are structurally different from the maximal projection of a Lexical Category.

To summarize, it seems that Condition 1, stated as in (1.71), is the only one of the conditions encoded in Stowell's version of X-bar theory which stands up under close scrutiny. The others are either not quite right or can be deduced from independent principles.

In this discussion of the X-bar schema, I am not denying that the internal structure of the major lexical categories shows various cross-category similarities. The point is that phrase markers are not primitives of the grammar, but are constructed out of the primitives, which are the relations expressed in the basic modes of discharge of theta positions. The range of possible phrase markers is not constrained by a primitive template or set of stipulated well-formedness conditions; rather, the possible phrase markers are just those of phrase markers which express the primitive relations. Cross-categorical similarities result from the fact that the number of primitive relations is quite limited.

1.5 Adjunction Constructions are Three-Dimensional

At the outset, I pointed out that the structural status of adjoined elements is largely unknown. In this section, I will show that the one theory of the formal properties of adjunction constructions which does exist, that of May (1985), amounts to a claim that all adjunction constructions are three-dimensional.

May discusses certain formal properties of adjunction structures, and makes several interesting proposals, which have subsequently been employed by Chomsky (1985). In particular, May points out that if one of the basic tenets of X-bar theory is to be that there is a one-to-one relation between heads and maximal projections, adjunction structures such as that in (1.72) seem to be in violation of X-bar theory, since there are apparently two tokens of the XP projection.

(1.72)

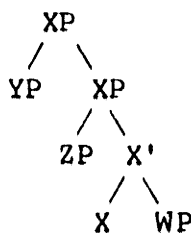

May proposes instead that a projection can be understood as "a set of occurrences of nodes that are featurally non-distinct (that is, identical with respect to syntactic features, bar level, index, etc.)." (May, p.56) Thus, in an adjunction construction like (1.73), the two tokens of XP are actually a single projection of the same node, as

they are featurally non-distinct members of the same projection set.

May goes on to argue that the domination relation should be understood as follows:

X dominates Y iff all members of the projection set of X dominate Y.

Under this view, an adjoined element is not really dominated by the category which appears as its mother (i.e., one segment of which appears as its mother) in the phrase structure tree. In (1.71) above, YP is not dominated by the category XP. Clearly, YP in (1.72) does not dominate the category XP either. Thus, under May's proposal, adjunction structures are structures for which the dominance relation simply does not hold.

It should be emphasized that May's suggested interpretation of the domination relation does not constitute a definition of domination, since it is itself stated in terms of domination. A more accurate statement of his observation might go as follows:

(1.74) A category X category-dominates Y iff all members of the projection set of X dominate Y.

We may well ask whether such a situation ought to be permitted. In fact, Lasnik and Kupin (1977), in their restrictive theory of phrase markers, require that any two nodes must be in either a precedence or a domination relation.

May also states that linear order is unspecified for LF adjunction structures. Taking May's theory to its logical conclusion, we would have to say that in LF adjunction structures (of the form (1.71)), no domination or precedence relation holds between XP and YP.

Lasnik and Kupin's theory might disallow such a situation, in particular if there is no way to distinguish among the segments of a given category. Goodall (1984), however, argues that phrase markers in which there are two monstrings neither of which dominates or precedes the other are precisely the phrase markers we need in the cases which have been called "Across-the Board" constructions.

If adjunction constructions are three-dimensional, then we predict that we might find Across-the-Board effects in non-coordinate constructions. In fact we do, however their analysis is not entirely straightforward. In particular, it is not obvious how ATB effects actually follow from the fact that some structure is three-dimensional. This issue will be taken up in Chapter 4, where I will show that certain Navajo relative clauses should be treated as ATB constructions.

Chapter 2

Configurationality: Variation in Projection of Structure

2.1 What is a "Nonconfigurational" Language?

The Thematic Structures which were proposed in the previous chapter bear many similarities to universal structures which have been proposed by various linguists, most notably the Lexical Structures of Hale(1983) and Mohanan(1983), the Virtual Structures of Zubizarreta and Vergnaud(1982) and the Logico-Semantic Structures of Marantz(1981). In fact, much recent research has been converging on the view that a hierarchical structure of this type is universal, even in languages whose surface constituency fails to reflect it the so-called "nonconfigurational languages".

This Chapter explores the parameters of linguistic variation which have come to be associated with the term "Configurationality Parameters." A certain amount of confusion exists as to exactly what is meant by this term, especially since recent work on the issue indicates that "there is no single 'parameter' giving rise to the various properties commonly associated with the term

"nonconfigurational." (Hale 1985:7) Rather, it appears that these superficial properties should be explained in terms of some set of deeper general principles. In this chapter, I would like to clarify what I believe is meant by the term "nonconfigurational" bringing together the diverse data which have been adduced as evidence for variation in "configurationality".

Investigation of the recent literature on the topic reveals that there are actually two related issues which are discussed under the rubric of "configurationality". One is the question of whether all languages distinguish structurally between subject and object at some level of representation, with the object being in a constituent VP which excludes the subject. The other issue is whether pronominal elements which appear on the surface as a subpart of a word can be serving as full arguments, so that overt NPs, when they appear, are in adjoined positions. As I will discuss in Section 2.2.7 Jelinek(1984) advocates stating a Configurationality Parameter in terms of the status of overt nominals as adjuncts due to the presence of pronominal clitics which are the true arguments.

These two questions, while related in fact, are logically independent. Let us call a hypothetical language which does not distinguish among arguments structurally a 'flat' language and a language in which pronominal elements may be arguments a 'PA' (for Pronominal Argument, following Jelinek) language; we can imagine that there might be languages of the following four types:

- (2.1) a. +FLAT, +PA
This would be a language in which pronominal elements saturated positions in theta grids, but neither the pronominal elements nor the adjoined NPs were distinguished on the basis of structural position at any level of representation.
- b. -FLAT, +PA
In this type of language, pronominal elements would saturate positions in theta grids, but these elements would be distinguished at some level on the basis of structural position.
- c. +FLAT, -PA
This would be a language in which only NPs could saturate positions in theta grids, and they did so on some basis other than structural configuration.
- d. -FLAT, -PA
In this type of language, only NPs could saturate positions in theta grids, and they would be distinguished in terms of structural configuration.

Linguists studying this sort of variation have been interested in discovering what deeper properties of languages might be responsible for apparent cross-linguistic differences in structural configuration. The Configurationality debate can be seen as a discussion of how best to parameterize the principles which project structures from lexical items. That is, "configurationality parameters" are those parameters which have to do with variation at the level of D-Structure, and observed surface differences follow from D-Structure differences.

As discussed in the previous chapters, projection from the lexicon to D-Structure is constrained by the Projection Principle and X-bar Theory (as deduced in our theory of saturation). Since these are the two subparts of the Grammar which constrain D-structure representations, "configurationality" parameters have been thought to be best expressed in terms of variation in the Projection Principle and/or X-bar theory.

The strongest interpretation of the principles given above would be the following:

- (2.2) The Projection Principle and X-bar theory give identical D-Structures for all languages, so all parametric variation must involve other modules of the Grammar.

The data to be presented in this chapter indicate that this strong hypothesis is false, for reasons which will become clear as we proceed.

Just what sorts of parametric variation might be expressible in terms of the Projection Principle and X-bar theory? In the earliest studies of configurationality within the Government and Binding framework i.e. Hale(1981 and preceding), variation at D-Structure was attributed to a parametric difference in the type of X-bar rules used by a given language to generate D-Structures. This proposal was made within a framework in which schematic X-bar rules constrained the well-formedness of trees which were freely generated. These tree structures were thought to be freely generated independent of lexical items, in contrast to the theory which I have presented so far, which I believe reflects a general trend within GB theory toward relating properties of structure to properties of lexical items.

Hale proposed that the rules of the base component of a given languages may be either of the 'X-bar' type, or of the 'W*' type. An X-bar language, such as English, would have base rules of the form in (2.3a), while a W* languages, such as Warlpiri, would have base rules of the form shown in (2.3b).

- (2.3) a. $X'' \rightarrow \text{spec } X'$
 $X' \rightarrow X \text{ complement}$
- b. $X' \rightarrow W^* X W^*$

On this view, English-type D-Structures are constrained by an X-bar schema which specifies two levels of hierarchical structure, while for Warlbiri-type D-Structures, the X-bar schema allows a phrasal node to dominate a head plus any string of words.

Since Hale originally made this proposal, research on X-bar theory has indicated that many (in the present work, all) of its properties are derivative of properties of lexical items. Those features of the X-bar schema which remain in the theory are so general that it seems clear that we would not expect to find variation of the sort proposed by Hale. Furthermore, as Hale himself points out, "it is also very reasonable to be skeptical of this approach and to argue that it simply begs a fundamental and more interesting question, namely: Why does Warlpiri use a phrase structure system of this highly 'permissive' type?" (1983:10).

Considerations such as these have led Hale and his colleagues in recent work to focus on possible variation in the application of the Projection Principle. The proposal presented in Hale(1983) is not that there may be languages which have no Projection Principle, but instead that each syntactic level of representation may have two types of structure and the Projection Principle may apply to only one of these. I term this proposal the 'Dual Representation Hypothesis', and I discuss its motivation at length in the following section.

As discussed in the introduction to this work, the Projection Principle has the effect of assuring the structural asymmetry between Subject and Object throughout the derivation. In other words, the Projection Principle allows structure to be projected from the lexicon, and also restricts the elements which fill structural positions. The definitional condition on D-Structure is ambiguous as it stands. The definitional condition is that D-Structure be a "pure representation of theta structure." As Hale(1983) notices, this definition has two aspects--theta roles and structure. The Projection Principle as it is currently conceived requires both that a selected argument be present at D-Structure (and all other syntactic levels), and that a selected argument be internal to a projection of its selecting head. Thus, variation in either the categorial presence of arguments or the structural realization of those arguments might be attributable to variation in the projection principle. Furthermore, it may be expected that if we can locate the correct parameter, then one of these two requirements might follow from the other. The goal of making the facts about structural realization of arguments follow from constraints on their presence, or vice versa, has been the underlying motivation behind much recent research.

Because the relationship between a set of linguistic data and its correct analysis is often quite opaque, a fairly detailed understanding of the working of a given language is required in order to discover the correct source of parametric variation. Fortunately, careful and insightful analyses of in several different languages have recently become available.

Before entering into the discussion of the evidence for D-Structure variation and the Dual Structure Hypothesis, an aside is necessary to discuss the relationship (or more precisely, the lack thereof) between 'free' word order and D-Structure variation. After discussing why less-than-rigid word order is not necessarily a diagnostic of variation at D-structure, I will present the data which have led to the Dual Structure Hypothesis.

2.1.1 A Digression about Word Order

It is something of an historical accident that the phenomenon of free word order has come to be closely associated with the configurationality issue. As Hale(1985) has emphasized, under the assumptions of current theory, "the phenomenon of free word order...is not criterial for nonconfigurationality, and it never has been." (Hale(1985:2)) Hale's statement is true because, as discussed extensively in Chapter 1, hierarchical relations in phrase structure are independent of linear precedence relations.

When Hale originally presented data from languages such as Warlpiri, Japanese and Papago to suggest that the rules generating D-Structures must be parameterized, the phenomenon of free word order became associated with the configurationality issue. This association was due to the model of D-Structure which existed at the time, in which Phrase Structure rules were thought to encode hierarchical structure and linear order simultaneously. Under such a conception of D-Structure, languages like Japanese or Warlpiri which do not have a fixed word

order pose a problem: if such languages are to fit in with such a model, a basic word order must be chosen and then some rule permuting the order must be proposed.

The intuitions of native speakers of some of these languages was that it is entirely unclear that any one of the possible word orders is more basic than any other.¹ This seemed particularly clear in the case of Warlpiri, where native speakers reported that sentences with permuted word orders counted as repetitions of each other. (see Hale (1981)) Given these native speaker intuitions, a theory which a basic word order was selected and then a scrambling transformation was applied did not seem to capture the spirit of what was really going on in the underlying structures of these languages.

As research proceeded on the nature of phrase structure rules, it was discovered that category-specific information could be factored out, leaving only a schematic "X-bar" rule. Farmer (1980) pointed out that schematization of the base rules made it clear that it was unnecessary to assume a base order for these languages and permute that order. Instead, using Japanese as a case study, she suggested that elements could be base-generated in any linear order, with the position of the head being the only necessary stipulation. Farmer hypothesized a flat structure for Japanese, and formulated her case-linking rules accordingly.

1. Speakers of Japanese generally do recognize a basic word order, namely SOV.

However, there is no necessary relation between category-independent phrase structure rules and flat structure. As outlined in Chapter 1, recent work within most frameworks, including Government and Binding Theory has adopted the view of McCawley(1978) Falk(1979) and Higginbotham(1985), among others, that although the phrase structure tree notation encodes both dominance and precedence relations, the principles of Grammar which determine domination and precedence relations are independent. Following the work of Huang(1981), Stowell(1981), Koopman (1983) and Travis(1984), among others, precedence relations can be captured in terms of direction of case and theta-role assignment by heads, presence or absence of a lexical INFL node, presence or absence of an adjacency requirement for case assignment, and presence or absence of a condition on domain adjacency, such as that proposed by Travis.

(2.4) DOMAIN ADJACENCY CONDITION

Given a direct relation R between a node W and a node X, where R involves sisterhood, if there is another node Y that does not enter into R with either W or X, then

*[...X ...Y...W...]

Direct relations are theta-role assignment and case assignment.
(Travis(1984:76)

Many of these authors assume that the word order parameters which they have proposed apply at the level of D-Structure Travis(1984), for example, proposes that there are "universal constraints on word order that restrict possible D-Structures."(1984:273) She advocates supplementing the head first/head final parameter proposed by Huang(1981) with parameterized direction of case assignment and

theta-role assignment and the Domain Adjacency Condition given above.

She does not examine the assumption that the head-order parameter applies at D-structure, probably because she holds the view of Chomsky(1984,85) that X-bar theory is relevant only at D-structure, therefore the notion head is only relevant at D-structure. Chomsky points out that adjunction operations seem to violate X-bar theory, therefore it appears that X-theory is relevant at D-structure only. However, it does not follow from the idea that X-bar principles are licensing principles at DS only that headedness is not visible at other levels. Assuming that it is possible to pick out heads at all levels, it is possible that the head order parameter might be stated at other than D-Structure. Considering recent work (Levin(1985)) which shows that some type of X-bar principles can be seen operating in phonology, it seems quite likely that the head of a construction can be picked out at any level.

As for the Domain Adjacency Condition, it is most likely applicable at D-Structure, since the relation of theta role assignment takes place at D-Structure. But notice that the DAC is only a linearization constraint in the sense that it prohibits, for example, adverbial elements from intruding into a case or theta domain.

- (2.5) a. Deborah [bought a book] yesterday. CASE DOMAIN
b. *Deborah bought yesterday a book.
- (2.6) a. Deborah [put a book on the table] yesterday. COMPLEMENT DOMAIN
b. *Deborah put a book yesterday on the table.
(ibid.:74)

Domination relations, on the other hand, are necessarily encoded at

D-structure. Thus we see that the parameters which determine possible variation at D-Structure can be studied independent of the parameters which determine word order. The phenomenon of free word order is related only indirectly to questions about the nature of D-Structure.

2.2 Evidence for Dual Representations

It is often assumed that "nonconfigurational languages" are those with "flat" structures, with the verb and all of its arguments dominated by a single node, while "configurational languages" are those languages which assign constituency to the verb plus its complements, resulting in a hierarchically organized sentence. However, this superficial characterization is misleading, since the variation data, taken as a whole, do not indicate simply that some languages are 'flat' while others are hierarchically structured. Rather, as Hale(1983) and Mohanan(1982a) have pointed out, these data seem to call for some sort of dual representation. That is, asymmetry in argument structure may in fact be universal, and certain syntactic relations refer this structure, while in some languages another, flat, structure is also needed for other syntactic relations.

In the discussion above, I pointed out that observed variation in word order does not necessarily give us evidence for variation in underlying syntactic structure. The underlying domination relations may be identical in various languages, but their surface structures may vary widely, depending on their choice of directionality parameters.

In the remainder of this chapter, I will be discussing data which cannot be explained in terms of directionality parameters. First, I will outline the facts which have led to the postulation of a structure for English in which the subject and object are distinguished structurally and the verb plus object form a surface constituent. I will then proceed to examine data from Warlpiri, Hungarian, Malayalam and Japanese which apparently cannot be explained under the assumption that these languages have exactly the same hierarchical structure as English. For each of these languages, I will first review the data which seem to show that subject and object must be structurally distinguished, and then I will review the data which it has been claimed show that the language in question must have a structural representation which is flat.

Many of the questions which will be raised as we examine these data are still open, and remain to be resolved by additional data and analysis by native speakers of these languages. My contribution to this particular effort cannot extend beyond compiling the data as it has been presented in the literature, comparing the claims which have been made about the various languages and discussing some points which I hope may lead to resolution of the open issues.

2.2.1 Subject/Object Asymmetries

Much recent research within GB theory has been directed toward discovering the nature and extent of observed asymmetries between the subject and object of a predicate. The evidence which I will review in

this section has led researchers to take the position that there exists a basic structural asymmetry in universal grammar between the object relation and the subject relation, whereby the grammatical relation object that held of an NP to the verb which is its structural sister, while the grammatical relation subject is that held of an NP which is external to a projection of the verb.

The first types of evidence are relatively theory-neutral, and bear on the constituency of the verb plus its object, as contrasted with the non-constituency of the verb plus its subject. The other arguments give more subtle evidence for the existence of underlying hierarchical structure, accounting naturally for a variety of facts which would seem intractable without the hypothesized hierarchical structure.

2.2.1.1 Verb plus Object Act as a Constituent

In English, the Verb along with its objects act as a constituent in the sense that movement rules, pronominalization, and deletion operations may apply to it as a unit.

- (2.7) a. Mary said she would win the race, and win the race she did.
b. Mary wrote a paper, and so did John.
c. Mary didn't see the article, but John did.

In these examples, the verb plus object acts as a syntactic constituent in that it may move, as in (a), be replaced by so, as in (b) or delete, as in (c). Under the fairly uncontroversial assumption that movement, pronominalization and deletion rules may refer to constituents only, these data provide evidence that English sentences have a constituent VP.

2.2.1.2 Asymmetric Influence on Thematic Role

Marantz(1984) gives examples like the following to argue that the choice of object arguments may influence the semantic role which is assigned to the subject, but not vice-versa.

- (2.8) a. throw a baseball
b. throw a boxing match (i.e. take a dive)
c. throw a party
d. throw a fit
e. take a book from the shelf
f. take a bus to New York
g. take a nap
h. take a letter in shorthand
i. kill a cockroach
j. kill a conversation
k. kill an evening watching t.v.
l. kill a bottle (i.e. empty it) (Marantz 1984:25)

- (2.9) a. The policeman threw NP.
b. The boxer threw NP.
c. The social director threw NP
d. Aardvarks throw NP.
e. Harry killed NP.
f. The drunk refused to kill NP
g. Cars kill NP. (Marantz 1984:26)

In examples such as these, Marantz argues, it appears that the verb plus object form a predicate, which subsequently assigns a semantic role to the subject. The subject of the predicate throw the ball is the ball-thrower, while the subject of the predicate throw a boxing match is the intentional loser of the match. In all of the cases in (2.8), choice of object determines the choice of subject. However, it is never the case that choice of subject determines choice of object. In (2.9), varying the subject does not limit the possible semantic role which the object will have. This sort of asymmetry is predicted in a theory (like Marantz's) in which the object and verb form a

constituent, to which the subject is external.

2.2.1.3 Idioms

As further evidence that the subject is external to the verb plus object, Marantz cites the preponderance of object over subject idioms, That is, we find many idioms like kick the bucket, but few if any idioms involving just the subject and verb.²

2.2.1.4 Some verbs are intransitive but all verbs take a subject

Another piece of evidence that the object is 'closer' to the verb than the subject is the fact that there is one category of verbs which do require an object, i.e. the transitive verbs, and another category of verbs which do not take an object, i.e., the intransitive verbs. Thus, a verb's lexical entry must include an indication of whether it takes an object or not. That is, the lexical entry either does or does not include some thematic role to be assigned to the object of the verb.

In English, at least, there is no such distinction between verbs which do and do not take subjects. In a tensed sentence, all verbs

2. Marantz argues that possible counterexamples always seem actually to be sentential in nature. Thus, an idiom like What's eating x? (pointed out by Bresnan) always maintains the same sentential syntax. of *What ate x

take subjects.³ If the verb assigns no thematic role to a subject, the subject position appears anyway, and is filled by either a pleonastic element, as in (2.10) a and b, or by an NP which received a theta role but failed to receive case in the embedded clause, as in (2.10)c.

- (2.10) a) It rained.
b) It seems that Sue has passed the exam.
c) Sue seems to have passed the exam.

The fact that the appearance of the subject is in no way dependent on the particular verb can be explained if we assume that a verb's lexical entry specifies whether it takes an object but does not so specify for its subject, subjects being universally required by independent principles. This lexical specification is instantiated in the syntax as direct theta marking under strict sisterhood. Since the verb does not select its subject, but only theta marks the subject indirectly (if at all), we may conclude that the object is a sister of the verb, but the subject is not.

3. Perlmutter (1978) proposes that there is a distinction between surface intransitive verbs whose surface subject is an underlying subject, which he calls 'unergative' verbs and those whose surface subject is an underlying object, which he calls 'unaccusative' verbs. The existence of unaccusative verbs complicates the discussion of subject/object asymmetries, particularly with respect to languages with case marking systems which differ from English. However, the fact remains that in English, even unaccusative verbs, which apparently assign a thematic role only to the object, there must be a subject on the surface. In addition to Perlmutter's work on these verb classes, see Burzio (1981) for an elaboration of the evidence for the unaccusative hypothesis (Burzio calls Perlmutter's unaccusative verbs 'ergative') and see Levin (1983) for extensive discussion of verb classes and ergativity.

2.2.1.5 Subject, but not object position may contain null pronominal

The distribution of the empty pronominal anaphor, PRO, in English indicates that the structural position of the subject has a different status from that of the object. PRO may appear only as the subject of an infinitival (and possibly as the subject of other predicates where there is no Case); PRO may never appear in object position, or as the subject of a tensed sentence.

- (2.11) a) Bill hopes PRO to win.
b) *Bill hopes that PRO will win.
c) *Bill hopes Jane will meet PRO.

The explanation for these facts in Government and Binding theory is that since PRO is both pronominal and anaphoric, it must obey both Binding Condition A (for anaphors) and Binding Condition B (for pronominals). Thus, PRO ought to be both bound and free in its governing category. Since it would be logically impossible for PRO to be both bound and free, PRO must lack a governing category, thus circumventing the binding conditions.⁴ In order to lack a governing category, PRO must appear only in positions where it is ungoverned, i.e., where it has no governor upon which a governing category can be defined. The subject of an infinitive must be ungoverned, while the object of a verb is governed. Thus, the distribution of PRO gives

4. This is essentially the proposal of Chomsky (1981). The statement of the Binding Conditions is reformulated in Chomsky (1985), but the fact that PRO, being both anaphoric and pronominal must fail to be governed in order to be exempt from the Binding Conditions is maintained.

evidence that the subject and object are structurally distinguished.

2.2.1.6 No nominative reflexive ('heself')

The distribution of the empty pronominal anaphor is only one of several ways in which facts about binding and coreference provide evidence that the subject and object are structurally distinguished. In fact, one of the most important advances of recent generative linguistics is the insight which has been provided into the restrictions on coreference among arguments. As discussed in the introduction, the three conditions of the Binding Theory are based upon structural configuration. We would expect, then, that cross-linguistic variation in structural configuration would be reflected in cross-linguistic differences in coreference possibilities.

Although the binding facts in various languages do point to a certain amount of structural variation, there is one generalization which seems to provide evidence for a universal structural distinction between subject and object. This is the fact that there are no languages which have only a nominative reflexive.

In English, as in many other languages, there is no nominative reflexive at all, i.e., the reflexive is always composed of the accusative pronoun + 'self'. In other languages, such as Hungarian, overt reflexives may bear nominative case. What is not found is a language which has no accusative reflexive but does have a nominative reflexive. Such a hypothetical language would be the reverse of the English case. That such a language cannot exist is predicted by a

theory of syntax in which the subject is structurally higher (or at least, is never lower) than the object.

2.2.1.7 The Binding Facts

In addition to the reflexive facts just discussed, conditions on coreference in general reveal an asymmetry between the subject and the object. The coreference facts of English are best explained under an analysis in which the subject is structurally higher than the object. There is evidence that in some languages the subject and object may be equal, but there are no languages in which the object is always structurally more prominent than the subject.

The Binding Conditions specify the binding requirements for a given type of NP, where bound is defined in terms of the structural relation c-command, as described in the Introduction.

Let us consider the empirical effects on coreference relations of the absence of the VP as a maximal constituent in a given language.⁵ If some language has a 'flat' structure, then the subject and object will c-command one another, therefore it is possible for the object to bind the subject.

With respect to sentences containing anaphors, the hypothesis that a

5. For the moment I will use the term 'flat' to refer to a language in which there is no VP constituent. The possible distinction between a language in which V rather than INFL is the head of S and one in which S is not binary branching will be discussed at the end of this section.

given language has a flat structure makes a prediction which is clearly false. Specifically, such an hypothesis predicts that simple reflexive sentences where the subject is an R-expression or simple pronoun should be ungrammatical; if the object c-commands the subject in a flat language, then the anaphor binds the subject NP in the following sentences:

- (2.12) a) He_i admires himself_i.
 b) John_i admires himself_i.
 c) John_i's mother admires him_i.

In (a), the anaphor would bind the pronoun, in violation of principle B. In (b), the anaphor would bind the R-expression, in violation of Principle C, and in (c), the pronoun would bind the R-expression, also violating Principle C.

In the case of pronominal coreference, if a given language has a flat structure, the coreference facts in simple sentences containing only NP and pronoun arguments ought to be identical to those in English.

- (2.13) a. Mary_i likes her_{j/*i}.
 b. She_i likes Mary_{j/*i}.

We would expect contrasts to show up in cases where the arguments are internally complex, containing NPs which do not c-command out of the minimal NP domain.

- (2.14) a. Mary_i likes her_i father.
 b. Mary's_i father likes her_i.
 c. Her_i father likes Mary_i.
 d. *She_i likes Mary_i's father.

Sentence (2.14a) is well-formed in English, because although the subject c-commands the object, the pronoun her is free within the NP object, so no principles are violated. Sentence (2.14b) is well-formed because the R-expression Mary, with which the pronoun her is coindexed, does not c-command the pronoun, although the NP Mary's father does c-command the pronoun. Similarly, in sentence (2.14c), the pronoun does not c-command the R-expression, nor vice versa. The structural asymmetry between subject and object shows up most clearly in the contrast between (2.14b) and (2.14d). In sentence (2.14d), the subject pronoun does c-command the R-expression Mary, and since R-expressions must be free everywhere, not just in a minimal domain, this sentence is ill-formed.

In a language in which the subject and object were at the same structural level, we would expect the judgements on the sentences corresponding to those in (2.14) to be as shown in (2.15).

(2.15) COREFERENCE IN A FLAT LANGUAGE:

- a. Mary_i likes her_i father.
- b. *Mary's_i father likes her_i.
- c. Her_i father likes Mary_i.
- d. *She_i likes Mary_i's father.

The pronouns which are within NPs would still be unbound, even if the subject and object were in a mutual c-command relation. However, sentence (2.15b) ought to be ungrammatical in a flat language, since the object will c-command the R-expression.

In fact, in most languages for which claims about flat structure have

been made, the linear order of anaphor and antecedent also appears to be relevant for the Binding conditions. Furthermore, as will be discussed in detail later in this chapter, the evidence regarding 'flat' languages actually shows not simply that some languages are flat while others are configurational; rather, the evidence indicates that some languages must have dual representations, with hierarchical structure being relevant for some of the Binding Principles but not for others.

Notice that the above definition of bound states that A binds B if A and B are coindexed and the least maximal projection dominating X dominates B. Actually, it seems to be the case that in English, a stronger form of c-command is the appropriate one among the various definitions proposed in the literature for the c-command relation. This stronger statement of c-command is in terms of the first branching node instead of the least maximal projection⁶ Chomsky refers to this other, weaker relation as m-command.

In many of the languages for which a flat structure has been proposed, there is little or no evidence that the INFL element is a fully-fledged category in the sense illustrated in Chapter 1 for English. In a language where INFL is not a syntactic category, V is the head of S. If we have a language in which V is the head of S, and

6. The definition in terms of the first branching node is often referred to as 'Reinhart c-command' and the definition in terms of the least maximal projection is often referred to as 'Aoun-Sportiche c-command'.

the relevant command relation for the purposes of binding theory is that of m-command, the binding conditions will not distinguish between the structures shown in (2.16a and b).

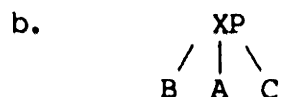
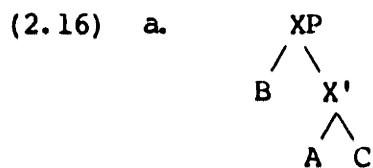

In structure (2.16a), node A M-commands node B but does not c-command B. In structure (2.16b), node A m-commands node B, and node A also c-commands node B. Therefore, if m-command should turn out to be the structural relation relevant for binding theory, then structures (2.16a) and (2.16b) are equivalent.

2.2.1.8 Weak Crossover

Those cases which have been termed 'weak crossover' cases receive a natural explanation in a theory in which the subject c-commands the object, but not vice versa. The relevant sentences are those shown in (2.17).

- (2.17) a. John_i loves his_i mother.
 b. His_i mother loves John_i.
 c. Who_i loves his_i mother?
 d. *Who_i does his_i mother love?
 e. Everyone_i loves his_i mother.
 f. *His_i mother loves everyone_i.

- g. JOHN_i loves his_i mother.
- h. *His_i mother loves JOHN_i.

The descriptive contrast between (2.17)b on the one hand and (2.17)d, f, and h, on the other, is that who, everyone, and JOHN (i.e., focussed NP) are all quantifiers which move to take scope, either at S-structure, as in d, or at LF, as in f and h.

Chomsky (1976) formulated the Leftness Condition to account for English weak crossover cases, and Koopman and Sportiche proposed that the correct condition did not refer to directionality, but was a more general condition on variable binding.

(2.18) LEFTNESS CONDITION (Chomsky (1976))
A variable cannot be the antecedent of a pronoun on its left.

(2.19) BIJECTION CONDITION (Koopman and Sportiche (1981))
Every Operator must locally bind exactly one variable,
and every variable must be bound by exactly one operator.

The subject object asymmetries observed in English sentences (2.17c-h) follow from the interaction between the Bijection Principle and Binding theory. When the trace of the operator is in subject position, that trace A-binds the pronoun in the object NP, therefore this pronoun is an anaphor, not a variable, and hence the operator binds one and only one variable. When the trace of the operator is in the object position, the pronoun is bound only by the operator, therefore the bound pronoun is a variable. Furthermore, the bound pronoun in weak crossover cases does not c-command the object trace, so that trace is also bound only by the operator, thus, the Bijection condition is violated.

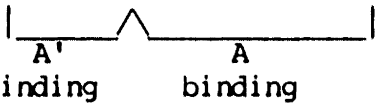
(2.20) c. Who_i t_i loves his_i mother?

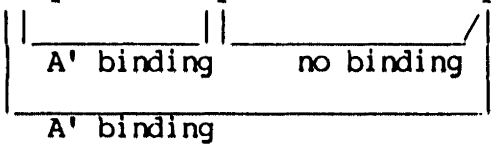
d. *Who_i does his_i mother love t_i?

The Bijection account of weak crossover facts has been questioned (Brody (1984), Safir (1984)), restated (Higginbotham (1984)), and much discussed, in particular insofar as it depends upon contextual definitions of empty categories. Elaboration of these issues would take us far afield. For present purposes, the important fact about weak crossover cases is that explanations for the surface asymmetries emerge as soon as we assume that (in English) the subject c-commands the object but the object does not c-command the subject.

2.2.1.9 ECP Facts

There is a general asymmetry with respect to extraction from subject position as contrasted with extraction from object position, as illustrated by the sentences in (2.21).

- (2.21) a. *Who_i did you say that e_i went in first?
 b. *Why_i did Mary claim [that Sue went in first e_i?]
 c. Who_i did you say that they called in e_i first?

This contrast can be explained by a very general condition, the Empty Category Principle (ECP), which informally states:

ECP: All empty categories must be properly governed.

The issue of how best to express this principle precisely is the subject of lively and ongoing debate. For various proposals, see Chomsky(1981), Huang(1982), Kayne(1984), Lasnik and Saito(1984), Aoun(1984), Longobardi(1982) and Pesetsky(1983), among others. Very loosely, we may say that whatever its correct formulation may be, the relation of proper government is a structural relation, therefore contrasts like (2.21a) vs (2.21b) and (2.21c) show that objects are structurally distinguished from subjects and adjuncts. In a flat language, we would expect that at least the equivalent of (2.21a) should be grammatical, since in a flat structure the subject would bear the same structural relation to the verb as the object would.

Superiority effects shown by English sentences such as (2.22a and b), are also attributable to the ECP, under the assumption that the WH-word which is in situ at S-Structure moves at Logical Form, leaving a trace which is subject to the ECP.

(2.22) a. Who gave what to Mary?

LF: $[_S, [_{COMP_i} \text{ what}_j] [_{COMP_i} \text{ who}_i]] [_S e_i \text{ gave } e_j \text{ to Mary}]$

b. *What did who give to Mary?

LF: $*[_S, [_{COMP_j} \text{ who}_i] [_{COMP_j} \text{ what}_j]] [_S e_i \text{ gave } e_j \text{ to Mary}]$

All of the subject/object asymmetries described above would be predicted if the sentence were assigned a structure in which the object is a sister to the verb, and the subject is external to the constituent VP, a maximal projection of the verb.

(2.23)

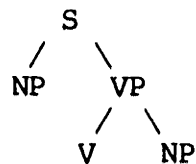

This is essentially the structure that the sentence is believed to have in the languages which are called "configurational" (ignoring, for the moment, the position of AUX or INFL in this structure). The data which have been taken as evidence for variation at D-Structure involve cases in which a given language appears not to exhibit the subject-object asymmetries which lead to the postulation of a structure like (2.23) for English.

2.2.2 Warlbiri

Hale has shown (1967-8, 1973, 1980, 1983) that the extreme freedom of word order exhibited by the Warlbiri language defies insightful analysis in a framework in which words must be base-generated in some specific position and then "scrambled" by a surface phonetic rule. First of all, in Warlbiri a simple transitive sentence may show any possible word order, with the only restriction being that the AUX element must be in second position, i.e. "Wackernagel's Position".

(2.24) Kurdu-ngku ka maliki wajilipi-nyi.
child-ERG AUX:pres dog chase-NONPST

Maliki ka kurdu-ngku wajilipi-nyi.
Maliki ka wajilipi-nyi kurdu-ngku.
Wajilipi-nyi ka kurdu-ngku maliki.
Wajilipi-nyi ka maliki kurdu-ngku.
Kurdu-ngku ka wajilipi-nyi maliki.

'The child is chasing the dog' (Hale 1980:1)

In these data, the word order variation shown in the examples is specifically variation in the order of constituents. Variation in constituent order can be captured by the parameters of case assignment, theta role assignment, predication, etc. outlined above.

However, Hale goes on to present evidence of a more radical sort. In Warlbiri, it appears to be the case that certain constituents can actually be split up in the surface string, resulting in grammatical sentences such as (2.25) (cf. (2.26)).

(2.25) Wawirri kapi-rna panti-rni yalumpu
kangaroo AUX spear NONPAST that
'I will spear that kangaroo.'

(2.26) Wawirri yalumpu kapi-rna panti-rni
kangaroo that AUX spear NONPAST
'I will spear that kangaroo.'

(Hale 1983:6)

In sentence (2.25), the demonstrative determiner yalumpu 'that' is separated in the string from the head noun wawirri, so that the NP constituent is apparently discontinuous. None of the parameters allowed so far would allow parts of an XP constituent to be linearized discontinuously.

Yet even in Warlbiri, there is evidence of the existence of the sort of subject/object asymmetry discussed in the preceding section. First, I will discuss the evidence in favor of some level of configurational structure in Warlbiri. Then I will review the facts which seem to call for a flat structure.

2.2.2.1 Subject/Object Asymmetries in Warlbiri

Hale(1983) argues that facts about control and reflexive-reciprocal interpretation lead to the conclusion that the grammatical functions Subject and Object are distinguished hierarcically in Warlbiri. The facts upon which he bases his argument are the following.

(2.27) a. Purda- nya nyi ka rna- .gku [wangka-nja-kurra].
aural percieve NONPST PRES lsubj 2obj speak INF COMP

'I hear you speaking'

b. Ngarka- patu ka- rna- jana nya- nyi [wawirri panti-rninja-kurra].
man PL PRES lsubj 33obj see NONPST kangaroo spear INF COMP

'I see the several men spearing a kangaroo'

c. Marlu- ku ka- rna- rla wurruka- nyi
kangaroo DAT PRES lsubj rla stalk NONPST

[marna nga-rninja kurra (-ku)].
grass eat-INF COMP DAT

'I am sneaking up on the kangaroo (while it is) eating grass.
(Hale 1983:20)

In these examples, the controlled argument is always the subject. Furthermore, the controller is also identified for some structures of obligatory control in Warlbiri. In the above sentences, in which the embedded infinitivals are marked with the complementizer kurra, the controller is the object of the matrix S. In (2.28), on the other hand, in which the embedded infinitival is marked with the complementizer karra, Hale reports that for most speakers the controller must be the

matrix subject.

(2.28) a. Ngarrka-ngku ka purlapa yunpa-rni
man EGR PRES corroboree sing NONPST

[karli janti- rninja- karra-rlu]
boomerang trim INF COMP ERG

'The man is singing a corroboree song while trimming the boomerang.'

b. Karnta ka- ju wangka-mi [yarla karla nja- karra]
woman PRES lobj speak NONPST yan dig INF COMP

'The woman is speaking to me while digging yams.'
(Hale 1983:20-21)

The Warlpiri reflexive/reciprocal marker nyanu occurs in place of the object marker in the AUX⁷, as shown in (2.29).

(2.29) a. Kurdu- jarra-rlu ka- pala- nyanu paka- rni.
child dual ERG PRES 33subj refl strike nonpst
'The two children are striking themselves/each other'

b. Ngarrka- patu- rlu ka- lu- nyanu kuruwarri yirra- rni
man pl erg pres 333subj refl design put nonpst
'The men are putting designs on themselves/each other'

In the reflexive/reciprocal construction, the subject binds the object, and never vice-versa. This is another of the ways in which the subject is more prominent in some sense than the objects.

To this sort of Binding and Control facts, Laughren(1986) adds the fact that case assignment to NPs is asymmetric:

(2.30) SUBJECT is obligatory with all verbs at LS: NP associated with the argument (or thematic role) bearing the subject grammatical relation: ERG or ABS case.

7. Except in first singular and second singular imperative, where the ordinary object markers are used in a reflexive function(Hale1983:21)

OBJECT is a property of a subset of verbs at LS: NP associated with the argument (or thematic role) bearing the object grammatical relation: ABS or DAT case. (p.3)

2.2.2.2 Evidence for a Flat Structure in Warlpiri

Although data like that presented in the preceding section lead both Hale and Laughren to conclude that binding and control in Warlpiri must be determined over a structure in which the subject and object are configurationally distinguished, there exists other evidence which indicates that Warlpiri surface strings are not configurationally arranged in the same way that English strings are.

Laughren shows that Warlpiri fails the standard tests for VP constituency:

(2.31) a) There is no PRO-verb 'do' (+so) in Warlpiri

b) V+obj may be coordinated. Whereas the English (*I cooked the meat and cut.) is ungrammatical, the equivalent is grammatical in Warlpiri:

Kuyu-rna purraja manu pajurnu-lku
meat-I cooked and cut-CHANGE
'I cooked the meat and cut(it). (ibid. p.2)

c) Any constituent may appear before the AUX; sentences where either [NP V] or [V NP] appear before the AUX are ungrammatical. Therefore, there is no constituent VP.

*Kuyu pajurnu-rna.
meat cut-AUX(1sg)
'I cut the meat'

*Pajurnu kuyu-rna.
cut meat-AUX(1sg)
'I cut the meat' (ibid. p.2)

Laughren further notes that the relatively free word order, the

presence of discontinuous constituents, the lack of pleonastic elements and the frequency of null pronominals are characteristic of the Warlpiri surface string. These features plus the failure of the tests for a constituent VP lead her and others to posit a dual representation for Warlpiri, in which a configurational structure is related, and this relationship is mediated by overt case.

Farmer, Hale and Tsujimura(1986) note that sentence (2.32), which is the closest Warlpiri equivalent to an English Weak Crossover violation, is fully grammatical.

(2.32) Ngana_i ka nyanungu_i-nyangu maliki-rli wajilipi-nyi?
 whom PRES he POSS dog ERG chase NONPAST

'Who_i is his_i dog chasing?'

(Farmer et al. 1986:34)

2.2.3 Japanese

Some of the earliest arguments against the strong hypothesis that all languages project identical underlying structures were those of Kuno(1973) and Hinds(1973) (reviewed in Whitman(1982)) which took the arguments for VP constituency in English and showed that they did not hold for Japanese. More recent work has investigated the consequences of the nonconfigurational analysis of Japanese for the theories of binding, control, etc, and have determined that there is substantial evidence of subject/object asymmetries in Japanese, and these asymmetries can only receive an explanatory account in a theory which posits an underlying configurational structure for Japanese.

2.2.3.1 Subject/Object Asymmetries in Japanese

Whitman(1984) discusses four different syntactic phenomena for which the most natural account must assume an underlying structural asymmetry between subject and object in Japanese.

First, Whitman shows that data involving r-expressions and the pronoun kare behave as though Binding Condition C were applying to representations in which a maximal projection intervened between subject and non-subject.

- (2.33) a. *Kare_i-ga John_i-no subete-no hon-ga suki da (to omo-u)
he-NOM -GEN all-GEN book-NOM like be COMP think-PRES
'(I think) he likes all of John's books.
- b. John_i-no itiban sitasi-i tomodate-ga kare_i-o uragit-ta.
-GEN most intimate friend-NOM him-ACC betray-PAST
'John_i's most intimate friend betrayed him_i'

Sentence (2.32) a is predicted⁸ to be ungrammatical whether the structure includes a VP or not; in both the flat structure and the hierarchical structure, the pronoun kare c-commands the r-expression

8. These predictions are based upon the assumption that structural configuration and not linear precedence is relevant to the binding conditions.

subjects, only subjects may be obligatorily controlled. These data are predicted if we assume that only PRO may be obligatorily controlled, and only subject position may be ungoverned. Whitman goes on to point out that no case has been found in any language of obligatory control of non-subject.

The third type of data which Whitman considers are those involving binding of reflexives. Japanese reflexives in S can be bound only by a subject.

(2.37) *John-ga Mary_i-ni zibun_i-ni tuite situmon si-ta.
 -NOM -DAT self-DAT about question PAST
 'John questioned Mary about herself'

Such examples seem to require that the subject be structurally distinguished from the object, although as Whitman points out, the assumption that Japanese has a configurational underlying structure still leaves unexplained the fact that only subjects may bind the reflexive.

The last phenomena reviewed by Whitman are those which have been cited as evidence that subjects must precede non-subjects in underlying structure. He presents data given by Masunaga(1982) and Kuroda(1980) to support the claim that Japanese has an underlying SOV word order.⁹

To data such as that given above, which appear to show clearly that Japanese does distinguish configurationally between subject and object,

9. I am omitting the examples given by Whitman, since the status of the judgements on them is not completely clear, according to Fukui (personal communication).

Saito(1985) adds various arguments that the word orders other than SOV are derived by means of movement and adjunction of the moved element to S. In (2.38) a and b, which are structurally parallel to Whitman's examples, the subject argument seems to c-command the object. In a sentence like (2.38)c, where the order of the arguments has been 'scrambled', the binding judgements indicate that the subject does not c-command the (scrambled) object.

(2.38) a. John_i-ga [NP Mary-ga kari_i-ne okutta tegami]-o mada
 John-nom Mary-nom he-to sent letter]-acc yet

yonde inai (koto)
 read have-not (fact)

'John_i has not read the letter Mary sent to him_i.'

b. 'Kare-ga_i [NP Mary-ga John_i-ne okutta tegami]-o mada
 he-nom Mary-nom John-to sent letter]-acc yet

yonde inai (koto)
 read have-not (fact)

'He_i has not read the letter Mary sent to John_i.'

c. [NP Mary-ga John_i-ne okutta tegami]-o kare-ga_i mada
 [Mary-nom John-to sent letter]-acc he-nom yet

yonde inai (koto)
 read have-not (fact)

'The letter Mary sent to John_i, he_i has not read.'

Saito gives the data in (2.39) to counter the possible objection that a simple precedence condition holds in Japanese. These data show that "a pronoun cannot c-command its antecedent even if the latter precedes the former" (Saito, p.44).

(2.39) a. [NP Kare_i-no okaasan-ga gendi-datta koro]-no John_i
 he-gen mother-nom well-was time -gen

Lit: John_i of the time when his_i mother was well,
='John_i as he_i was when his_i mother was well.'

b.? [NP Kare_i-no okaasan-ga gendi-datta koro]-no Kare_i

c. * [NP John_i-no okaasan-ga gendi-datta koro]-no Kare_i

Additional arguments that scrambling involves a movement operation which adjoins the moved constituent to S are found in Saito and Hoji (1983) and Saito (1985).

2.2.3.2 Evidence for a Flat Structure in Japanese

The existence of rules such as 'do-so substitution' which refer to the VP as a constituent but not to the subject plus the verb as a unit provide evidence that the VP is a constituent in English. In Japanese, the similar phrase soo su is not so restricted; examples like (2.40) lead Hinds (1973) to conclude that soo su replacement does not refer to a constituent VP.

- (2.40) a. Mary wrote a book carefully, and Kate did so too.
b. *Mary wrote a book and Kate did so a dissertation.

- (2.41) a. Taroo-wa teinei-ni hon-o ka-i-ta; ronbun-mo soo s-i-ta.
-TOP carefully book-OM write-past report-also so do-past
'Taro wrote the book carefully; (he) did so too the dissertation'

Similarly, Hinds (1973) pointed out that deletion of the VP as a constituent, which is grammatical in English, as shown in (2.42) a, is ungrammatical in Japanese, as shown in (2.42) b.

- (2.42) a) Mary watched T.V. and John did too.¹⁰

10. Examples from Whitman (1984)

b) *Mary-wa TV-o mi-ta John-mo si-ta.
 Mary-theme TV-acc see-past John-also do-past

(2.43) a) Mary watched T.V. and John did so too.

b) Mary-wa TV-o mi-ta John-mo soo si-ta.
 Mary-theme TV-acc see-past John-also thus do-past

Hinds contended that given the lack of evidence that Japanese has a constituent VP, postulation of a VP node for Japanese would constitute a complication of the Grammar. On the grounds of simplicity, then, he argues that Japanese should be considered to have a 'flat' structure.

Hasegawa(1980) points out a flaw in this conception of simplicity, showing that the postulation of a flat structure for Japanese has various consequences which themselves lead to significant complication of the grammar. She argues that failure of the standard VP-constituency tests for Japanese lead us to conclude that the VP constituent is not necessary in Japanese, but these tests should not be taken as evidence that Japanese cannot have a VP. She presents properties of certain verbs which she calls "dependent verbs" ¹¹ which cannot receive an explanatory account unless a VP is assumed in underlying structure.

It should be pointed out that there is a distinction to be made between tests which indicate that the Verb forms some constituent with its object, versus those which indicate that the Verb plus its object form a maximal projection. Fukui(1986) points out, as did Whitman,

 11. The "dependent verbs" are the causative marker sase and the passive marker rare. Hasegawa claims that these must take a VP complement, therefore, Japanese must have a VP constituent.

that if we consider the Sentence in Japanese to be a projection of V, as opposed to INFL in English, then we find that Japanese V+NP forms a non-maximal constituent, which is nonetheless a constituent. Thus, we would expect Japanese to fail tests that involve movement, deletion, etc of a maximal constituent, while displaying structural asymmetries nonetheless.

2.2.4 Hungarian

A relative freedom of word order, associated with the fact that Hungarian NPs bear overt case markers, has led many authors to examine the possibility that Hungarian falls into a category of "nonconfigurational" languages. However, the earliest studies of Hungarian syntax in the GB framework (Horvath(1981), Kiss(1981), Szabolcsi(1981)) provide evidence that assigning a totally flat structure to Hungarian sentences does not adequately capture the facts of that language. There exists a rich body of literature on Hungarian linguistics, some of it within the GB framework, which is written in Hungarian. Because I am familiar only with the literature which is written in English, I can provide no more than a sketchy overview of the lively debate which has grown up around these issues during the past 5 years. Linguists interested in Hungarian have by no means reached agreement on the correct analysis of the facts to be presented in this section. Some linguists hold the view that Hungarian has fully configurational underlying structures, since such structures appear to be universal in some sense and it is possible to give an account of Hungarian along configurational lines. Others, not as convinced that

subject and object are universally distinguished structurally at D-Structure, believe that the evidence shows that Hungarian has a flat underlying structure. Still others have adopted the position that the Hungarian evidence can best be accounted for by positing dual representations: a configurational Lexical Structure and a flat Phrase Structure.

The debate on the status of Hungarian freedom of word order has been largely concerned with the fact that while surface word order in Hungarian does not uniformly represent grammatical relations, the different word orders do appear to reflect different focus and topic assignments. For example, while (2.44a and b) have the same interpretation (according to Kiss(1985)), in (2.44c-j), the interpretation varies depending upon the position of the NPs and the placement of primary stress (marked here with the symbol ˈ).

- (2.44) a. Kereste Jánost a főnöke.
 looked-for John-acc the boss-his-nom
 'His boss was looking for John'
- b. Kereste a főnöke Jánost.
 'His boss was looking for John'
- c. Jánost kereste a főnöke. 'It was John who his boss was looking for'
- d. A főnöke kereste Jánost. 'It was his boss who was looking for John'
- e. Jánost 'kereste a főnöke. 'John was looked for by his boss'
- f. A főnöke 'kereste Jánost. 'His boss was looking for John.'
- g. Jánost a főnöke 'kereste. 'John, his boss was looking for'
- h. A főnöke Jánost 'kereste. 'John, his boss was looking for'[sic]
- i. Jánost a főnöke kereste. 'John was looked for by HIS BOSS'
- j. A főnöke Jánost kereste. 'His boss was looking for JOHN'
 (Kiss 1985:4-5)

Kiss describes these word order permutations in some detail. She acknowledges that free word order is not necessarily incompatible with a configurational analysis which includes a scrambling rule, but she compares Hungarian word orders with those available in Italian, a language which has preposed objects as well as postposed subjects. Kiss suggests that the differences between Hungarian and Italian with respect to word order permutations points to deeper differences in underlying structure.

2.2.4.1 Subject/Object Asymmetries in Hungarian

Although the word order data presented in the previous section, as well as the more complex data which will be presented in the section to follow provide evidence in favor of an underlying structure for Hungarian in which the arguments of a verb are all sisters, there does exist evidence which seems clearly to show that the subject and object cannot be sisters, at least for the purposes of certain grammatical principles.

In particular, data from reflexive binding and control (or, more accurately, the distribution of PRO) has been presented by Kiesel and Maracz (1984), Szabolsci (1983), Kiss (1985) and Maracz (1986). The reflexive data show that a more structurally prominent NP may bind a 'lower' NP, but not vice versa.

(2.45) REFLEXIVE:

- a. János és Mari szeretik egymást.
 John and Mary love each other-ACC
 'John and Mary love each other'

- b. A lányokat bemutatam egymásnak.
the girls-ACC introduced-I each other-DAT
'I introduced the girls to each other'
- c. *János és Mária szeretik egymás.
John-ACC and Mary-ACC love each other-NOM
'Each other love John and Mary'
- d. *A lányoknak bemutatam egymást.
the girls-DAT introduced-I each other-ACC
'I introduced each other to the girls'
(Kiss 1985:28)

Infinitival complements have a set of properties which suggest that subjects are structurally distinguished from objects. For instance, controlled PRO may appear as a subject but not as an object, and the external argument in an infinitival construction may receive a special case marking, while the internal arguments are unaffected.

(2.46) CONTROL:

- a. Jánosnak kell-eett lát-ni-(a) Mária.
John-DAT must-pst see-*INFIN*-3sgAGR Mary-ACC
'John had to see Mary'
- b. János lát-t-a Mária.
John-NOM see-pst-3sgAGR Mary-ACC
(Mácz 1986)

Mácz further shows that data from predication, switch reference, and noun incorporation support the contention that Hungarian does in fact distinguish structurally between subject and object.

2.2.4.2 Evidence for a Flat Structure in Hungarian

A number of scholars have applied more sophisticated syntactic tests to Hungarian data, and have found substantial evidence in favor of an underlying structure in which the arguments of the verb are sisters;

i.e., a structure in which there is no VP. The data which I will present in this section have been discussed by a number of authors, including Kenesei (1984), Horvath (1981, 1986), Kiss (1981, 1985), Szabolcsi (1984) de Mey and Maracz (1984) and Maracz (1985, 1986). Kiss (1985) includes a summary of the main arguments in favor of a flat underlying structure for Hungarian.

Kiss shows that applying the standard VP tests to Hungarian reveals no evidence of a VP constituent.

For example, no rule moving VP as a constituent is known to exist. Kiss cites the following example.

- (2.47) János szeretne átmenni a vizsgán, és *átmenni a vizsgán fog.
 John would-like to-pass the exam and to-pass the exam he-will
 (Kiss 1985:7)

Kiss cites Komlosy as having observed that in Hungarian, the selection of the subject can influence interpretation of the object, whereas in English the influence can only go the other way (see section 2.2).

- (2.48) a) Az oroszlán eszi Jánost.
 the lion-nom eats John-acc
 'The lion is eating John.'
- b) Az irigység eszi Jánost.
 the envy-nom eats John-acc
 'Envy is eating John.'
- c) A méreg eszi Jánost.
 the anger-nom eats John-acc
 'Anger is eating John.'
- d) A féne eszi Jánost.
 the plague-nom eats John-acc
 'The plague is eating John.' (= John is over-anxious)

When an agent subject is selected, as in (a), the object is the theme. When the subject is a theme, the object is an experiencer, as in (b) and (c). In (d), idiomatic meaning is assigned to the subject plus verb.¹²

The subject/object asymmetries which are observed in English in sentences in which WH-movement has taken place do not occur in Hungarian. Whereas in English, extraction from object position is grammatical and extraction from subject is ungrammatical in cases like (2.49) a and b, the corresponding extractions in Hungarian are both grammatical.

- (2.49) a) *Who_i did you say that e_i went in first?
 b) Who_i did you say that they called in e_i first?

- (2.50) a) Kit_i mondtál, hogy elsőnek ment be e_i
 who said-you that first went in
 'Who did you say that went in first?'
 b) Kit_i mondtál, hogy elsőnek hívták be e_i?
 whom said-you that first called-they in
 'Who did you say that they called in first?'
 (Kiss 1985:12)

Similarly, Hungarian does not display the Superiority effects shown by English sentences such as (2.51a and b), which, as discussed in section (2.2.1.9), are also attributable to the ECP, under the assumption that

12. Kiss gives various other examples of Hungarian idioms in which the variable position is some position other than subject, and she refers the reader to O. Nagy (year unspecified) for hundreds of other examples. However, these examples (unlike those above involving subject plus verb) are all of the type that Marantz (1984) has argued do not constitute evidence against a VP constituent. The interested reader can consider and evaluate the arguments which Marantz gives.

the WH-word which is in situ at S-Structure moves at Logical Form, leaving a trace which is subject to the ECP.

(2.51) a. Who gave what to Mary?

b. *What did who give to Mary?

(2.52) a. Ki_i mit_j $adott$ $Mari$ ak e_i e_j ?
 who what-acc gave Mary-dat
 'Who gave what to Mary'

b. Mit_i ki_j $adott$ $Mari$ ak e_i e_j ?
 what-acc who gave Mary-dat
 'What did who give to Mary'

(Kiss 1985:19)

If the correct explanation for these Subject/Object extraction asymmetries is in terms of the ECP, along the lines of Huang(1981) or Lasnik and Saito(1984), then assignment of a structure with a VP and an external subject NP for Hungarian would incorrectly predict that sentences like (2.51) should be ungrammatical. In English, the subject position is not properly governed, therefore, extraction of the subject violates the ECP. Since this ECP violation does not show up in Hungarian, we may conclude that the subject position in Hungarian is properly governed by the verb; that is, that there are no underlying structural asymmetries between the subject and the object.

Extraction from subject position is grammatical in Hungarian, not only over the declarative complementizer hogy 'that', but also across a WH phrase. According to the analysis of Horvath(1981), in (2.53a and b), the WH phrase is in COMP at S-Structure and in (2.53a and b), the WH phrase is in COMP at LF.

- (2.53) a) Ezt a színésznő_i még gyerek voltam, amikor már
 this the actress-nom still child was-I when already
 főszerepeket játszott e_i.
 leading:roles-acc played
 'This actress I was still a child when was already playing leading roles.'
- b) Ezt a színésznőt_i még gyerek voltam, amikor már
 this the actress-acc still child was-I when already
 az egész ország ismerte e_i.
 the whole country knew
 'This actress I was still a child when the whole country knew already'
- (2.54) a) Az egyetlen ember, aki nem tudom,
 the only man who not know-I
 hogy mikor láthatja e Marit, János.
 that when can-see Mary-acc John
 'The only man who I don't know when can see Mary is John.'
- b) Az egyetlen ember, akit nem tudom, hogy mikor láthat e Mari, János.
 the only man whom not know-I that when can-see Mary-nom John
 'The only man who I don't know when Mary can see is John.'
- (2.55) a) [_{NP} az az állítás [_S hogy (ő_i) szelhamos]] felháborított a Jánost_i
 that claim that he fraud infuriated John-ACC
 "The claim that he_i was a fraud infuriated John_i."
- b)* [_{NP} az az állítás [_S hogy (ő_i) szelhamos]] felháborította mindenkit_i
 that claim that he fraud infuriated everyone-ACC
 * "The claim that he_i was a fraud infuriated everyone_i."
- c) a férfi [_S aki [_{NP} az az állítás
 the man who that claim
 [_S hogy (ő_i) szelhamos]] felháborította t_i elment
 that he fraud infuriated left
 (Kenesei and Maracz 1984:3)

(2.56) a) * θ_i nem olvasta [NP_a Mari által Jánosnak_i küldött level]-et
 he_i not read the Mary by John-to sent Letter-ACC
 *"He_i has not read the letter sent to John_i by Mary.

b) *[NP_a Mari által Jánosnak_i küldött level]-et θ_i nem olvasta
 the Mary by John-to sent letter-ACC he not read
 (Kenesi and Maracz 1984.5)

If we assume an underlying structure with a VP for Hungarian, then (2.56) a is simply parallel to the equivalent English sentence, and the explanation for its ungrammaticality would be the same as that of the English sentence: the pronoun o c-commands the R-expression John and therefore the two cannot be coindexed, by Principle C of the Binding theory. However, now (2.56)b, in which the complex NP object precedes the pronominal subject, poses a problem. If we assume that Hungarian sentences have a VP at D-Structure, then we must assume that sentence (2.56)b is derived through an application of move alpha, which adjoins the accusative NP to the S node, along the lines suggested for Japanese scrambling by Hoji and Saito(1984). Such an analysis predicts that (2.56)b should be grammatical, since no c-command relation holds between the R-expression and the pronoun in the derived structure.

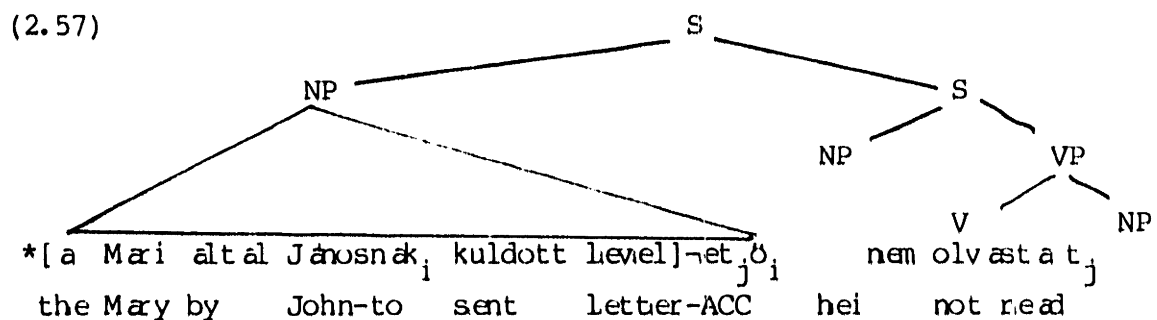

The Japanese equivalent of (2.56)b is grammatical, and this is one of the important pieces of evidence which lead Hoji and Saito to conclude that Japanese D-Structures have a VP. Kenesi and Maracz point out that

following Hoji and Saito's line of reasoning leads to the conclusion that the Hungarian sentence (2.56)b is not derived from a D-Structure with a VP; rather it is base generated by rules which generate flat structures.

If the underlying structure of a given language is flat, then we would expect coreference between a pronoun and an R-expression to be ruled out by Binding Condition C regardless of whether the R-expression is in the subject or object. That is, whereas (2.58a) contrasts with (2.58b) in that the pronoun does not c-command the R-expression John in (2.58a), while the pronoun does c-command the R-expression in (2.58b).

- (2.58) a. John_i's mother loves him_i.
 b. *He_i loves John_i's mother.

Kiss(1985) shows that, just as predicted by a flat structure account, both of these sentences are ungrammatical in Hungarian.

- (2.59) a. *János_i anyja szereti őt/pro_i
 John's mother loves him
 b. *Ő/pro_i szereti János_i anyját
 He loves John's mother
- (2.60) a. *Kinek_i az anyja szereti őt/pro_i
 Whose the mother-NOM loves him
 'Whose mother loves him?'
 b. *Kinek_i az anyját szereti ő/pro_i
 whose the mother loves he
 'Whose mother does he love?'

The final data to be presented in this section have to do with "weak crossover" sentences, which are ungrammatical in English but grammatical in Hungarian.

- (2.61) a. John_i loves his_i mother.
 b. His_i mother loves John_i.
 c. Who_i loves his_i mother?
 d. *Who_i does his_i mother love?
 e. Everyone_i loves his_i mother.
 f. *His_i mother loves everyone_i.
 g. JOHN_i loves his_i mother.
 h. *His_i mother loves JOHN_i.

The subject/object asymmetry displayed by the weak crossover facts in English does not show up in Hungarian.

- (2.62) a. ki_i/ mindenki_i/ JANOS_i szereti az pro_i anyját
 who-NOM everyone-NOM JOHN-NOM loves the his mother
 'Who_i/everyone_i/JOHN_i loves his_i mother.'
 b. Kit_i szeret az pro_i anyja?
 who-acc loves the his mother-NOM
 'Who_i does his_i mother love?'
 c. Mindenkit_i szeret az pro_i anyja.
 everyone-acc loves the his mother-NOM
 'His_i mother loves everyone_i.'
 d. JÁNOST_i szeret az pro_i anyja.
 JOHN-ACC loves the his mother-NOM
 'His_i mother loves JOHN_i.'

(Márta 1985)

Keeping all other assumptions fixed, these Hungarian cases seem to show that in Hungarian, the subject and object are in a mutual c-command relationship. Recall that sentences like (2.56) showed that Saito and Hoji's account of Japanese weak crossover violations cannot be extended to Hungarian. That is, we cannot simply say that the

objects in (2.61) have been moved by means of move- α and adjoined to S, because this would predict that (2.61b-d) should be ungrammatical. If we assume that whichever condition ruling out the weak crossover cases in English applies in Hungarian to a flat structure, then we correctly predict that sentences (2.61) will show no subject/object asymmetries.

I will end this section with a complication which raises interesting questions. Maracz(1986) presents the following additional data indicating that a Bijection (or leftness) condition applying to a flat structure still does not make all of the right predictions for Hungarian.

- (2.63) a. Mindenki_i szeret az pro_i anyj_a.
 everyone-ACC loves the his mother-NOM
 'His_i mother loves everyone_i.'
- b. Az anyj_at mindenki szereti 'Everyone_i loves his_i mother'
- c. *Az anyj_a szeret mindenki 'His_i mother loves everyone_i'
- d. *Az anyj_at szereti mindenki 'Everyone_i loves his_i mother'

The ungrammatical examples differ minimally from the grammatical ones in that ill-formedness results when the quantifier is placed following the verb. Maracz's suggestion to account for these data is a condition on the licensing of quantifiers in surface structure (in particular, in Hale's 'Phrase Structure(PS)'): (This condition is a version of Haik(1981)'s condition on Indirect Binding.)

- (2.64) Quantifiers are licensed at PS iff:
 (i) they are governed by a verb OR
 (ii) they are in the scope of a licensed quantifier

2.2.5 Malayalam

In a series of articles in both the GB and the LFG frameworks, Mohanan has argued that Malayalam is best analyzed as having dual structures at each of the syntactic levels of representation. In the LFG framework, these two types of structure simply correspond to the Constituent Structure and Functional Structure, the two types of representation which LFG posits for all languages. Within the GB framework, the existence of two types of structure is somewhat more controversial. Mohanan essentially elaborates Hale's theory, in which the two types of structure are termed 'Phrase (or Constituent) Structure' and 'Lexical Structure.'

2.2.5.1 Subject/Object Asymmetries in Malayalam

Mohanan (1983) presents evidence from reflexive binding that Malayalam exhibits subject/object asymmetries. In particular, data such as the following show that reflexives must always be bound by subjects.

- (2.65) *joon billine swaṅṅam wiṭṭil we coḍ pulli.*
 John-nom Bill-acc self's house-loc at pinched
 'John pinched Bill at John's/*Bill's/*someone else's house.'
- Joonaal billa swaṅṅam wiṭṭil we coḍ pull apṅṅtu.*
 John-ins Bill-nom self's house-loc at pinch-pass-pst
 'Bill was pinched by John at Bill's/*John's/*someone else's house.'

Facts like these lead Mohanan to conclude that Malayalam must have some representation where subject is distinguished from object, either structurally, as in GB theory, or functionally, as in LFG.

2.2.5.2 Evidence for a Flat Structure in Malayalam

Mohanan argues that Malayalam has a flat Phrase Structure representation on the basis of three types of evidence. First, he states that there are no rules in Malayalam which refer to a VP constituent, therefore he suggests that postulation of such a node "would be an unmotivated artifact...(and) would unnecessarily complicate the word order phenomena, obscuring the generalization that it is only the sister constituents directly dominated by S that are order-free." (1982:525)

Secondly, many of the rules which refer to configuration in English, such as the binding conditions and the interpretation of quantifier scope, seem to refer instead to precedence relations in Malayalam. Consider the following paradigm (from Mohanan 1983:120).

- (2.66) a. $ku\ddot{t}\ddot{t}i_1$ $awante_1$ $ammaye$ $nu\ddot{l}li$.
child-nom his mother-acc pinched
'The child pinched his mother.'
- b. * $awante_1$ $ammaye$ $ku\ddot{t}\ddot{t}i_1$ $nu\ddot{l}li$
his mother-acc child-nom pinched
'His mother, the child pinched'
- c. * $awan_1$ $ku\ddot{t}\ddot{t}iyuute_1$ $ammaye$ $nu\ddot{l}li$
he child's mother-acc pinched
'He pinched the child's mother'
- d. $ku\ddot{t}\ddot{t}iyuute_1$ $ammaye$ $awan_1$ $nu\ddot{l}li$
child's mother-acc he pinched
'The child's mother, he pinched.'

If we were to assume that Malayalam has fully configurational D-structures, and that the accusative...nominative word order displayed by (2.65)b and d results from an application of 'move-alpha', as Hoji and Saito have argued for Japanese, then these sentences will have the following structures:

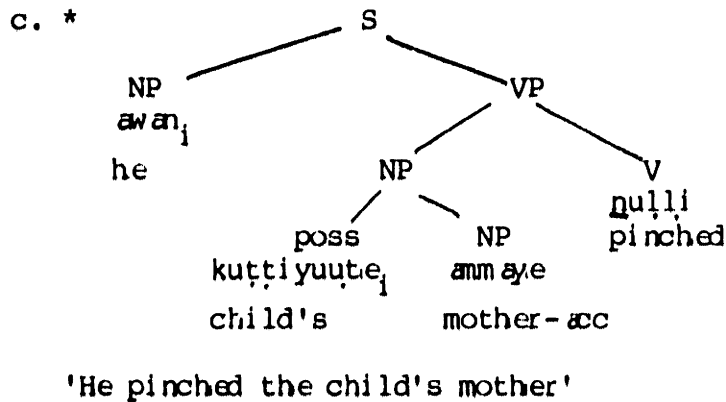
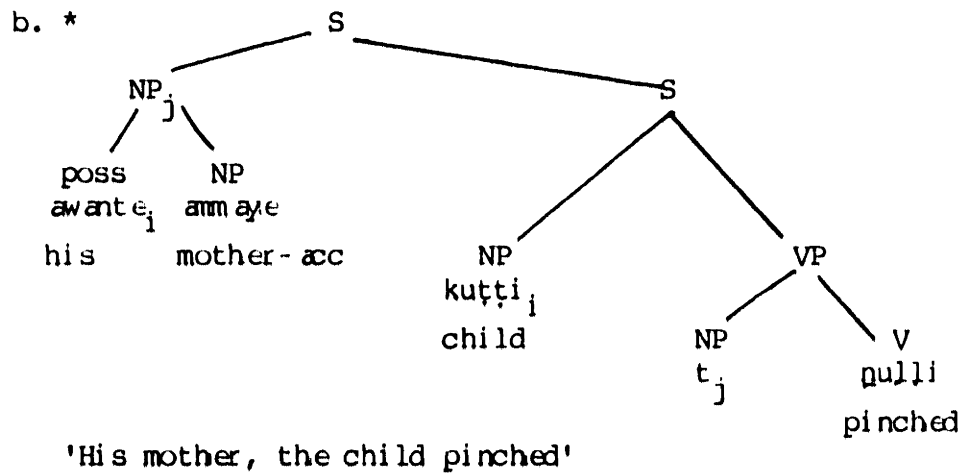
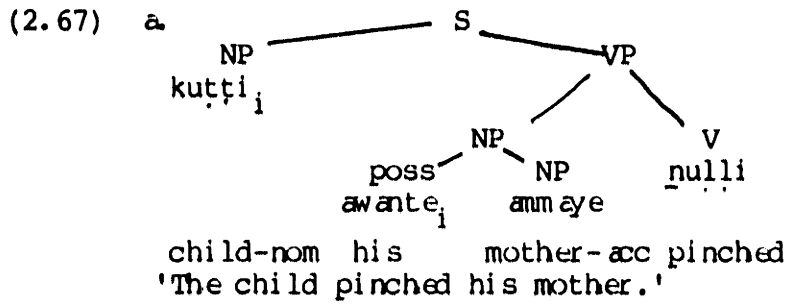

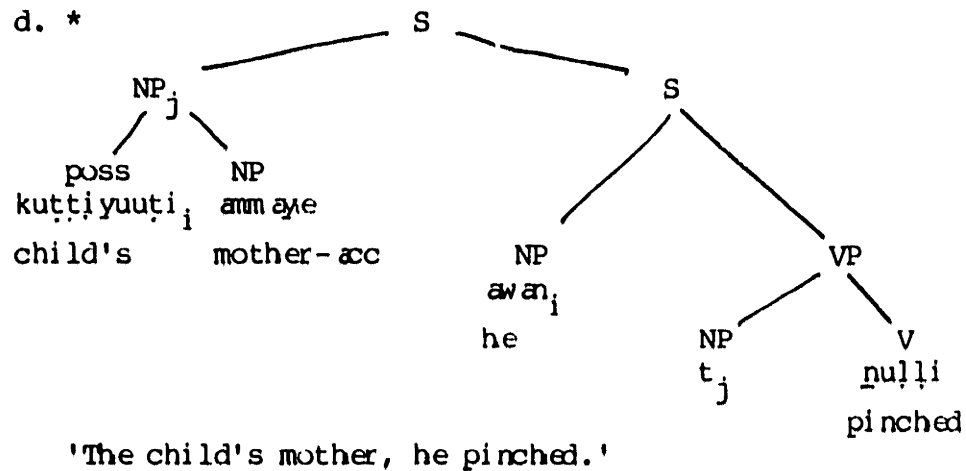

Note that the pronoun satisfies condition B of the binding theory under either the flat structure or the configurational structure hypothesis, since in all four cases, the pronoun is either not c-commanded by the R-expression or is the specifier of an NP, and thus is free in that NP, which is its governing category.

The problematic case is (2.66c). In the structure above, none of the binding conditions are violated, so the sentence ought to be grammatical. The fact that the binding conditions as applied to a configurational structure seem to be insufficient for Malayalam leads Mohanan to suggest that the correct rule for coreference in Malayalam is (2.68):

(2.68) A pronoun must not precede its antecedent. (1983:120)

If the coreference conditions in Malayalam refer to precedence rather than domination relations, then some of the most convincing arguments for configurational structures are obviated. This precedence requirement leads Mohanan to reject an analysis of the Malayalam word order facts in terms of movement from an underlying configurational

structure, because the independent precedence requirement renders a configurational structure superfluous.

It is interesting to note that Saito does not include a Japanese sentence parallel to (2.65)b in his discussion of the coreference facts in that language. He argues that a precedence condition on coreference such as Mohanan's cannot be sufficient for Japanese because sentences like the following, repeated here as (2.69) show a clear contrast in grammaticality.

- (2.69) a. [NP Kare_i-no okaasan-ga gendi-datta koro]-no John_i
 he-gen mother-nom well-was time-gen
 Lit: John_i of the time when his_i mother was well,
 ='John_i as he_i was when his_i mother was well.'
- b.? [NP Kare_i-no okaasan-ga gendi-datta koro]-no Kare_i
- c. * [NP John_i-no okaasan-ga gendi-datta koro]-no Kare_i

These sentences show that in Japanese, a pronoun cannot c-command its antecedent regardless of linear order. So Saito's data indicate that a precedence constraint is not sufficient for coreference relations, however the question remains whether a precedence constraint is necessary. A Japanese sentence parallel to the Malayalam sentence (2.66)b would provide a crucial bit of evidence, since in this sentence, no c-command relation holds between the pronoun and the R-expression. Therefore, the precedence constraint appears to be necessary to rule the sentence out. The crucial Japanese sentence would be something like (2.70).

(2.70) Kare_i-no hahaoya-o John_i-ga aisite iru (koto)
 his-GEN mother-ACC John-NOM loves (fact)
 'His mother, John loves'

According to Fukui (personal communication), this sentence is grammatical. The grammaticality of this sentence provides evidence that Japanese coreference relations are not constrained by a precedence requirement like the one which Mohanan proposes for Malayalam. Furthermore, the contrast between the above Japanese sentence, which is grammatical, and the equivalent sentence in Malayalam, which is ungrammatical, indicates that it is not possible to straightforwardly extend Hoji and Saito's account of scrambling in Japanese to Malayalam.

It should also be noted that sentence (2.65b) would be incorrectly predicted to be ungrammatical under an account like the one given in the previous section for Hungarian, where the underlying structure was flat yet the binding conditions referred to structural configuration. If sentence has a flat underlying structure, then the pronoun awan c-commands the R-expression kuttiyuute, in violation of binding condition C. In Mohanan's theory, this is not a problem, because he maintains that the coreference conditions for Malayalam refer to precedence relations and not to domination relations.

Although it does seem to be true that extending Hoji and Saito's account of scrambling to Malayalam is not sufficient to capture the facts without some sort of precedence condition, it should be emphasized that the existence of a precedence condition on the antecedence relation does not provide an argument that Malayalam

sentences must be flat. If Mohanan is right that coreference relations in Malayalam refer to precedence but not to domination, then the domination relations in Malayalam might be exactly as in Japanese, or even as in English.

Interpretation of quantificational expressions in Malayalam also depends upon precedence relations. Sentences (2.71a and b) are not ambiguous: the preceding quantifier always has wider scope.

- (2.71) a. ellaawārum cilaā'e patti aalooiccu.
everyone some about thought
'For all x, there is some y such that x thought about y.
- b. cilaā'e patti ellaawārum aalooiccu.
some about everyone thought
'There is some y such that for all x, x thought about y.

As in the case of coreference relations, we cannot necessarily infer from the fact that precedence is relevant for quantifier interpretation that the structures of the above sentences are flat. Furthermore, as Fukui (1986) points out, an analysis in which scrambling rules are all fronting (as opposed to postposing) rules, an analysis in which scrambling is an instance of move- α is indistinguishable from an analysis in which NPs are base generated in random order and then rules of interpretation refer to linear order. Thus, in the above sentences with quantificational NPs, we have no way of knowing (in the absence of independent evidence such as crossover judgements) whether the

structure is as shown in (2.72a) or (2.72b),

(2.72) a.

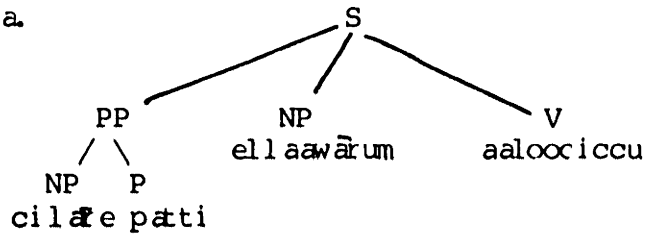

b.

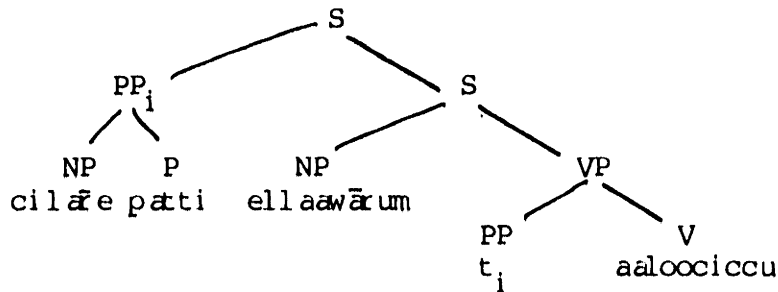

Mohanan believes that "clefts offer the strongest support to the flat structure hypothesis." (1982:526) The construction which he calls clefting is one in which the morpheme -ā¹³, 'it' is attached to the verb and a form of aa, 'be' is attached to the clefted or focussed constituent. Assuming that the subject, object and verb are all immediate daughters of S allows a simple way of expressing which constituents may cleft: all and only daughters of S may cleft.

(2.73) a. kuḷāṭṭil wecca¹³ jooṇinte kuṭṭi aanaye nulli. (unclefted)
 pond at John's child elephant pinched
 'John's child pinched the elephant at the pond'

b. kuḷāṭṭil wecca¹³ jooṇinte kutti aanaye nulliya¹³
 at-is pinched-it
 'It was at the pond that John's child pinched the elephant'

c. *kuḷāṭṭil aa¹³ jooṇinte kuṭṭi aanaye nulliya¹³
 pond-is pinched-if (1982:529)

13. In these examples, I am using the symbol 'ḷ' to represent schwa.

The PP, which, under Mohanan's analysis is an immediate daughter of S, can be clefted, but the NP cannot be clefted out of the PP.

Mohanan's assumption is that there is a rule of clefting which refers in its structural description to particular types of constituents. There is no overt movement in these constructions, therefore Mohanan assumes that there is no gap or binding relation. However, suppose we treat these constructions along the lines proposed by Birss, Hale Perkins and Speas (1986), who treat a similar construction in Navajo as a case of movement at Logical Form.¹⁴ Then the fact that only daughters of S can be "clefted" would follow from the general conditions on move-alpha. In the case of local "clefting", we would predict (I think correctly, judging from Mahanan's examples) that the grammaticality judgements should be parallel to those for English. The one exception to this is the above case of "clefting" out of a prepositional phrase. It is well known that at least in the case of overt movement, languages vary with respect to the acceptability of a gap within a prepositional phrase:

- (2.74) a. (It was) the pond that the child saw the dog at e.
b. *(C'était) l'étang que l'enfant a vu le chien à e.

If we treat the Malayalam "clefting" construction as a case of Logical Form movement, then it may be that the ill-formedness of the

14. In the Navajo construction, a focus particle is attached to the focussed constituent only; no alteration is made to the verb.

sentence in which an NP has been "clefted" within a PP result from a more general restriction on the possible licensors for gaps.

Mohanan(1982) considers two other interesting constructions, which I think can also receive an explanation under an LF movement account:

- (2.75) a. $\bar{r}aajaaw\textcircled{a}$ kuṭṭiye kaḷḷan aayi kaṇakkaakki
king child thief was considered
'The king considered the child a thief'
- b. $\bar{r}aajaawaan\textcircled{a}$ kuṭṭiye kaḷḷan aayi kaṇakkaakkiyaṭ\textcircled{a}
king-is considered-it
'It was the king who considered the child a thief'
- c. $\bar{r}aajaaw\textcircled{a}$ kuṭṭiyeaan\textcircled{a} kaḷḷan aayi kaṇakkaakkiyaṭ\textcircled{a}
child-is considered-it
'It was the child that the king considered a thief'
- d. $\bar{r}aajaaw\textcircled{a}$ kuṭṭiye kaḷḷan aayi kaṇakkaakkukayaan\textcircled{a} ceṭṭaṭ\textcircled{a}
consider (inf)-is did-it
'What the king did was to consider the child a thief'
- e. * $\bar{r}aajaaw\textcircled{a}$ kuṭṭiye kaḷḷanaan\textcircled{a} aayi kaṇakkaakkiyaṭ\textcircled{a}¹⁵
thief-is considered-it
'It was a thief that the king considered the child'

In the absence of additional data, it would not be worthwhile for me to speculate on the actual formulation of an LF-movement account of this construction. For this paradigm, however, it is worth pointing out that the one sentence which is ungrammatical in Malayalam is ungrammatical in English as well.

The final fact about clefting which Mohanan brings to bear on his

15. Mohanan states that a-d are the only possible clefts for this string, so I made up this example to complete the paradigm.

flat structure proposal for Malayalam is that unlike English clefting, Malayalam clefting is clause bounded.

(2.76) *amma aanayeyaan₃ nulli en₃ kutti parāñā₃.
mother elephant-is pinched that child said-it
'It was the elephant that the child said the mother pinched'
(M 112: 531)

In the Barss et al. analysis of Navajo focus, similar locality restrictions are given an account in terms of subjacency, based upon independent evidence that S in Navajo is a Barrier. Again, more data would be needed to test whether such an account could be extended to Malayalam.

All my comments on Mohanan's analysis have been speculative. Their purpose has been to make it clear that Mohanan has shown that Malayalam might have a flat structure, but that it would require arguments like those which have been given for Hungarian to make a case that Malayalam must have a flat structure.

2.2.5.3 VSO Languages

In a language whose unmarked word order is Verb-Subject-Object, such as Samoan, Tongan, Welsh, Irish, Breton, Chamorro, etc, the question naturally arises whether such a language may or must have some representation in which the verb forms a constituent with its object. Anderson and Chung (1977) considered data from Samoan, Tongan and Breton, and their preliminary conclusion was that "In VSO languages, as well as in other types of languages, rules exist which are sensitive to a structural difference between subjects and objects." (1977:25).

Sproat (1985) uses data from Welsh to argue that

1. VSO languages have a base generated VP, and the VSO order is derived via a verb-fronting rule.
2. The reason that this rule exists has to do with the directionality of case assignment by INFL.
3. The subject position in VSO languages is not properly governed by the fronted verb.

The third claim disputes the contention of Chung (1983) that data from the VSO language Chamorro show that the subject is properly governed by the verb. In particular, Sproat suggests an alternative analysis for alleged violations of constraints against extraction from subject position:

(2.77) Hayi_i na palaw'an ti un- tungu'
who LINKER woman not INFL-2s-know
[na ginin t-um-átangis e_i]
COMP IMPERF INFL(s)-cry+IMPERFECTIVE

'Which girl didn't you realize [that] had been crying?'

(2.78) Hayi_i siguru [na pära u- ginäna i karera e_i]
Who INFL(s) COMP FUT INFL(3s)-betwon the race
'Who is [that the race will be won by ___] certain?'
(Sproat 1985:209)

Whereas Chung claimed that (2.77) provided evidence that the subject position is properly governed in Chamorro, Sproat points out that since Chamorro is a 'pro-drop' language, in which the subject nominal may be inverted (and, following the analysis of Italian given by Rizzi (1982),

adjoined to VP), example (2.77) does not necessarily show that the subject position is properly governed. Instead, the correct structure of (2.77) may be (2.79):

(2.79) Hayi_i na palao'an ti un- tungu'
 who LINKER woman not INFL-2s-know
 [na ginin t-un-átangis_j e_i] [t_j e_i]
 COMP IMPERF INFL(s)-cry+IMPERFECTIVE

'Which girl didn't you realize [that] had been crying?'

As for the second example, Sproat speculates that this may actually be a case of extraction from an extraposed subject position, and thus parallel to (2.80a) rather than (2.80b).

(2.80) a. Who is it certain [that the race will be won by ___]?
 b. *Who is [that the race was won by ___] certain?

Thus, Sproat argues that Chung's evidence is not conclusive in favor of a flat structure for Chamorro¹⁶. Furthermore, evidence from the VSO languages which he investigates is in favor of a configurational underlying structure.

It should be noted that the VSO language Samoan is a possible counterexample to the hypothesis that binding of reflexives is a universal indicator of subject/object asymmetry. In the following data, from Chapin(1970), we see that the reflexive morpheme may be

16. Actually, Chung is arguing for a distinction between constituent structure and relational structure, and the arguments regarding the position of subjects given here have to do with constituent structure.

nominative, but that the reflexive may not precede its antecedent.

(2.81) Sa sogi e Ioane (o) ia lava.
aux cut nom¹⁷ John acc him self
'John cut himself.'

Sa sogi Ioane e ia lava.
aux cut (acc)John nom him self
'Himself cut John.'

*Sa sogi e ia lava Ioane .
aux cut nom him self (acc)John
'Himself cut John.'

*Sa sogi ia lava e Ioane.
aux cut (acc) him self nom John
'Himself cut John.'

'O Ioane sa sogi o ia
'It was John who cut him(it, her)' or
'It was John who cut himself.'

'O ia lava sa sogi e Ioane.
'It was him_j, *i that John_i cut'

2.2.6 Summary of Evidence

We may summarize the evidence covered in the preceding sections with the following matrix, where '+' indicates that the relevant test shows a structural asymmetry for the language in question, and '-' indicates that the test shows a lack of such asymmetry. Where I have provided no data, I left a blank. The obligatory subjects test was marked with a question mark, because while we do know that none of the languages have overt pleonastic subjects, there is no evidence that I know of

17. Chapin, working within the framework of Fillmore's Case Grammar, calls the case markers 'agentive' and 'objective'. I will call them 'nominative' and 'accusative' simply for the sake of consistency with the other examples.

regarding the possible existence of null pleonastics in these languages.

(2.82)	Warl	Jap	Hun	Mal
V+O as Constituent	-	-	-	-
Influence on Th-Role				
Idioms	-		-	
All verbs take subject	?	?	?	?
PRO	+		+	
Reflexive	+	+	+	+
Binding Facts	-	+	-	+
Weak Crossover	?	+	-	?
ECP Facts	?	+	-	?

2.2.7 The Dual Representation Hypothesis

Evidence such as that in the preceding section, in which a flat structure seems to be required for certain principles of the Grammar while a hierarchical structure is required for others, led Hale(1983) to propose that "lexical structure" (LS) be considered a representation separate from "phrase structure." (PS) Since clearly we know that the phonetic spellout of a sentence differs from the form which represents logical relations, it seems plausible to separate the representations, and allow some processes to apply to lexical structure and others to apply to phrase structure.

- a) In configurational languages, the Projection Principle holds of the pair (LS, PS).
- b) In non-configurational languages, the Projection Principle holds of LS alone. (Hale 1983:26)

Notice that this bifurcation immediately gives us an explanation for the possible cooccurrence in a language of evidence of a flat structure and extensive use of null pronominals: since the lexical structure can represent the verb's thematic requirements, there is apparently no need for null pronominals in the PS. That is, we can consider PS to be quite close to the phonetic representation in that if a word is not pronounced, it is not necessarily represented in PS. Nothing rules out empty elements at PS, but as long as no other principles require their presence, the projection principle as stated above does not require empty pronominals at PS. Thus, we would expect more frequent "pro-drop" in languages for which the mapping between LS and PS is not an isomorphism.

Hale maintained that frequent "pro-drop" is one of a cluster of surface properties that may be diagnostics of a language's nonconfigurational status. Hale(1983) lists the following properties as being possible diagnostics of "non-configurationality":

- a. "free" word order
- b. the use of discontinuous expressions
- c. free or frequent pronoun drop
- d. lack of NP movement transformations
- e. lack of pleonastic NPs
- f. use of a rich Case system
- g. complex verb words or verb-cum-AUX systems.

Recent research has made it clear that the above list does not actually constitute a "cluster" of properties which all necessarily fall out from some deep parameter. Saito and Hoji, for example, have argued that Japanese D-Structures are fully configurational, yet pronoun drop is quite frequent in Japanese. We find many other

languages which show various combinations of the properties. German has rich case but infrequent pro-drop. Spanish has frequent pro-drop but no overt case. Navajo has frequent pro-drop, no pleonastics, and complex verb word, but rigid word order. The fact that the cluster of properties which Hale's theory predicts do not in fact form a cluster calls his theory into question.

Also problematic is the formal status of the relation which links LS and PS in his theory. Hale calls the relation "resumption", expressing a possible parallel between this relation and the relation between resumptive pronouns and their binders. If resumption is indeed the same relation as that which holds, for example, between the NPs and the pronouns in (2.83), then it is not clear that two distinct representations are necessary.

- (2.83) a) My mother, she's always yelling at me.
b) It was John who I wondered whether he liked me.
c) As for Einstein, the claim that he slept 10 hours a night is true.

Notice further, that in languages which Hale classifies as non-configurational, the relation between the verb at LS and the verb at PS is always one of identity, not resumption. Thus, resumption is strictly a relation between NPs; verbs are never related by means of resumption. The Dual Representation hypothesis predicts that we might find languages in which a verb was represented in the Lexical Structure but simply not present in the Phrase Structure. It makes this prediction because it posits two separate structures with a mapping relation between them and the possibility that a given category may be present in one but not in the other. While we do find gapping, where

the verb can be identified because it must be identical with the verb in the other clause(2.84a), and there are languages like Hebrew in which the copula(or, in some languages, a verb of possession) may be null(see Rapoport(1985)), we do not find any languages in which morphology on the nominals freely allows various verbs to be absent from the Surface string, such as the presumably impossible hypothetical sentences in (2.84b and c)

- (2.84) a) Mary wrote a novel and Susan (e) a sonnet. (e=wrote)
 b)***Mary wrote a novel and Susan-og (e) it. (e=read)
 c)***The dog-ulp (e) the small child. (e=chased)

2.2.8 Pronominal Argument Languages vs. Lexical Argument Languages

Jelinek(1984) suggests that dual representations are unnecessary if we revise the Configurationality Parameter as follows:

CONFIGURATIONALITY PARAMETER(extended)

- a. In a configurational language, object nominals are properly governed by the verb.
- b. In a W-type non-configurational language, nominals are not verbal arguments, but are optional adjuncts to the clitic pronouns that serve as verbal arguments. (1984:73)

Jelinek's stated intention is to "propose configurationality parameters which are directly compatible with the Projection Principle" (1984:43). The parameter which she proposes captures the intuition that the morphemes which she calls "clitic pronouns" (which might alternatively be termed "rich agr") seem to be sufficient to satisfy the verbal thematic requirements, making overt nominals extra in some sense. However, in this section I will argue that her formulation of

the Configurationality Parameter cannot in fact both capture the relevant parametric variation and maintain the projection principle as a universal and invariant principle.

First, let us consider the four logically possible ways that we might instantiate the proposal that clitic pronouns serve as arguments, with overt nominals acting as adjuncts. Jelenek refers to those languages in which clitic pronouns serve as arguments "Pronominal Argument languages". The four logically possible structures for a simple transitive sentence in a Pronominal Argument language are shown in (2.85).

(2.85)
a)

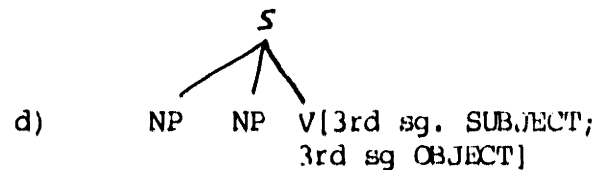
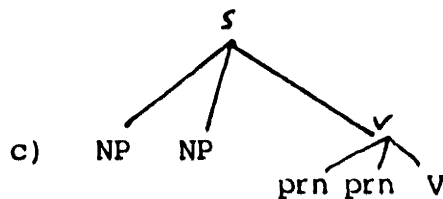
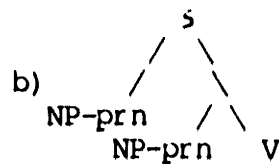
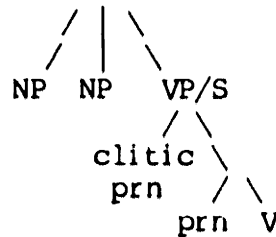

Structures a and b obey the Projection Principle, which, as discussed in the Introduction, requires that a verb's theta-marking properties, including the distinction between its direct and indirect arguments, be given syntactic instantiation. Using structure a or b, we can maintain the Projection Principle and the universal structural definition of Subject and Object.

The other two structures do not obey the Projection Principle. This

point is somewhat obscured in Jelinek's discussion of the universality of the Projection Principle. She quotes Marantz (1978), who expresses the intuition behind the Projection Principle as:

(2.86) Grammatical Relations must be expressed at surface structure.
(Marantz 1978:88)

Jelinek goes on to say "A sentence with no surface indications of grammatical relations would be uninterpretable." (1984:43) It should be emphasized that the hypothesis that grammatical relations are universally structurally defined is central to Government and Binding Theory, so when Marantz says that Grammatical relations must be expressed at surface structure, this means that the surface structure must either be a branching structure in which the object is a sister to the verb and the subject is not, or must be linked to such a structure via linking rules of the type proposed by Hale.

Since Grammatical Relations are structurally defined in GB theory, the clitic pronouns in the structures shown in the (2.83)c and d do not give a surface indication of Grammatical Relations, as they are not in structurally-defined argument positions at surface structure. Therefore, (2.83)c and d cannot be considered to satisfy the Projection Principle, since the verbal property of distinguishing between the internal and external arguments has not been projected into the syntax in these structures. To assign one of these structures to sentences for some languages would constitute a claim that the Projection Principle operates differently in such languages; Jelinek explicitly rejects such a claim. Therefore, we must conclude that Pronominal Argument languages have structures like a or b.

For Warlbiri, it is possible to assign structures like a or b, as long as we have some PF rule to position the clitic pronouns in the second (Wackernagel's) position. Thus, we could propose that Warlbiri D-structures look like (2.87).

- (2.87) Wawirri kapi-rna-0 panti-rni yalumpu.
 kangaroo AUX:lsgsubj-3sgobj spear-NONPST that
 'I will spear that kangaroo'

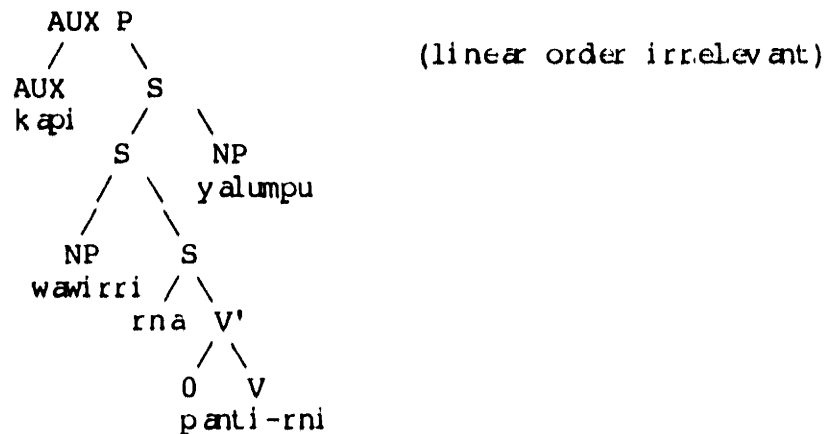

Following Jelenek (1984), we can claim that the argument positions which project along with the matrix verb at D-structure are fully identified by the AUX elements. The overt nominals which appear in the Warlbiri example above are adjoined to S, which is a projection of the Verb plus tense. Notice that since Warlbiri has no linearization constraints (aside from the later positioning of the AUX), the Nominal elements may be adjoined either to the left or to the right. (Of course, linearization is not effected at D-Structure anyway, but the limitations of paper force the diagram to show a linear order.)

It should be emphasized that the positions of the adjoined nominals are not really "positions" in the traditional sense, that is, they are not made available at D-Structure by an independent principle of

grammar in the way that argument positions are. In particular, when these nominal elements do not appear on the surface, no principle of grammar requires an adjoined NP position, therefore, there can be no empty categories found in these positions.

A Theory of case-linking, along the lines of Jelinek(1984) or Laughren(1986), can be applied to structures like (2.85), to account for the well-formed resumption relations between the case-marked nominals and the pronominal arguments.

The surface differences between Warlbiri and English under Jelinek's account follow primarily from the fact that nominals may appear in adjoined positions, because the clitic pronouns fill argument positions.

In the remainder of this Chapter, I will argue that this simple account cannot be maintained, for conceptual as well as empirical reasons. First, I will claim that Jelinek's parameter does not correctly capture the cross-linguistic distinction. Then I will take issue with the contention that overt nominals in Navajo are adjuncts, showing that the available syntactic tests indicate that these nominals are in argument positions. This will lead into Chapter 3, where I investigate the status of the Navajo agreement clitics.

Expressing the configurationality parameter in terms of the availability of pronominal (clitic) arguments plus the option of adjoining nominal phrases seems to make the wrong cross-linguistic distinction. Consider the fact that nominals in English may be

arguments, modifiers, binders, predicates or adjuncts, as shown in (2.88).

- (2.88) a. Mary saw John.
b. I'd like you to meet my friend Rita.
c. We consider Mary the best person for the job.
d. Artichokes_i, I like e_i
e. My mother_i, she_i's amazing.

Notice further that while some readers may object that sentences like (e), in which the nominal is an adjunct, are marked in English and common in Warlpiri, it is not at all clear that these constructions are marked. Consider the sentences in (2.89).¹⁸

- (2.89) a) This place, man, I really hate it.
b) My car, man, I thought it would never make it over here.
c) That guy, man, who does he think he is?
d) My mother, man, she's amazing.

With the "topic particle"¹⁹, these sentences seem totally grammatical. Thus, the proposal that a non-configurational language is one in which pronominal elements may be arguments could force us to classify English as such a language.

These examples of resumption in English make it clear that the important difference between Warlpiri and English is not that pronominal clitics can be arguments which can be further modified by nominal adjuncts. The important difference is that the pronominals are

18. I thank Michele Sigler and Andy Barss for bringing these to my attention. Some properties of these sentences are explored in Greenberg (1984)

19. It was Michelle Sigler (p.c.) who suggested to me that man is a topic particle here.

clitics, that is that they are in some sense sub-parts of a word rather than independent words themselves. Adjoined nominals are not ruled out in English; what is ruled out in English is for a sub-part of a word to satisfy the thematic requirements of that word.

That the distinction is not between languages that have adjoined nominals and those that don't, but rather between languages in which sub-parts of a word fill argument "positions" and those in which they do not is made clear if we consider the fact that we do not find languages in which independent pronouns are always obligatory, and nominals may be adjoined to S, and linked to these pronouns via the resumption relation.²⁰

Clitic pronouns have the syntactic features of independent pronouns, and it is reasonable to suppose that the fact that they attach to another word is a purely phonetic property. Thus, the phonetic and syntactic properties of pronominal elements are independent, as evidenced by the fact that a pronoun may or may not be a clitic, and a clitic may or may not be a pronoun, as the examples in (2.90) show.

- (2.90) a. +pronoun, +clitic: Insisto en hacerlo. (Spanish)
 insist-I on to do-it
 'I insist on doing it'
- b. +pronoun, -clitic: We sell sea shells.
- c. -pronoun, +clitic: John 's house

20. Note that some Romance clitics are thought to originate in argument positions, but on the surface they appear either as a sub-part of the verb or as a sub-part of INFL. See Chapter 3.

Since the phonetic and syntactic properties of clitic pronouns are independent, Jelinek's expression of the Configurationality Parameter predicts that we should find languages in which overt nominals are not governed by the verb, and non-clitic pronouns obligatorily fill argument positions, that is, where sentences like (2.91) are the usual case.

(2.91) The children they are playing with it the cat.

To my knowledge, there are no languages in which independent pronouns are always present in the sentence. The languages which Hale, Jelinek and others have studied seem to be languages in which the thematic requirements of the verb are satisfied within some complex word (either the verb or the AUX (INFL)).

If it turns out to be true that there is parametric variation between languages in which a sub-part of a word can "be" an argument and those in which it cannot, it is difficult to see exactly how the projection principle could be maintained in its present form. As pointed out above, the Projection Principle requires that if a verb selects an argument as a lexical property, then that argument must be represented categorially at all syntactic levels. The only way that pronominal clitics may "count" as categorial representations at the syntactic levels is if the clitics are detached from the word at the syntactic levels, and only cliticize onto the word at PF, and as I have just pointed out, if we allow such an analysis of Warlpiri, we make the incorrect prediction that we will find languages in which independent pronouns, that is, pronouns which do not happen to be clitics in

Phonetic Form, are obligatory.

Furthermore, the proposal that a sub-part of a word is serving as a syntactic argument clearly violates an hypothesis which has been at the core of research on the interaction between the lexicon and syntax since Chomsky's (1970) "Remarks on Nominalization", that is the hypothesis that syntactic rules do not refer to sub parts of lexical items. Lapointe(1981) expresses a strong form of this hypothesis as the General Lexical Hypothesis:

(2.92) GENERAL LEXICAL HYPOTHESIS:

No syntactic rule can refer to an element of morphological structure.

Lapointe²¹(1981:)

It should be noted that the proposal that a language like Warlpiri has D-Structures with pronominal clitics in argument positions as illustrated above is my own interpretation of how the Projection Principle might be preserved under Jelinek's version of the Configurationality Parameter. In her more recent work, the structures which she assigns to sentences in Pronominal Argument Languages indicate that the Projection Principle is not being maintained. For example, she and Merton Sandoval give the following structure for a

21. See Lapointe(1978), Allen(1978), Lieber(1980), and Kiparsky(1982) for discussion of this principle

sentence in Apache:

(2.93)

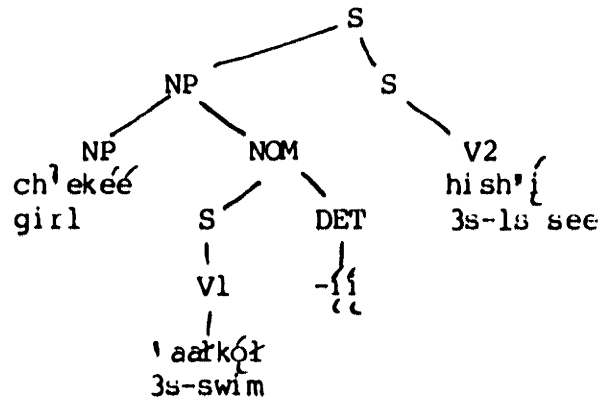

'I see the girl who is swimming' (Sandoval and Jelinek 1986: 34)

Willie (1986), claiming that Navajo is a Pronominal Argument Language, gives the following structure for a Navajo sentence:

(2.94)

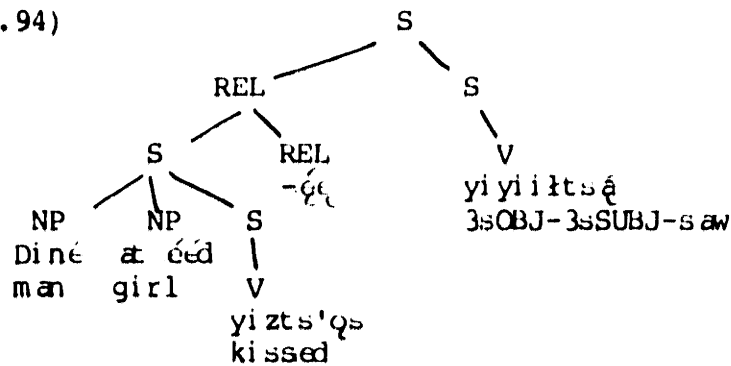

'Someone[sic]²² (Willie 1986: 16)

These representations do not obey the Projection Principle. The person and number of the verbal arguments are clearly indicated on the verb, but the Projection Principle requires that these arguments be

22. It may be more appropriate to translate this sentence as 'He/she saw the man who kissed the girl', since the verb in this case contains the null third person subject prefix rather than the indefinite subject prefix.

given syntactic instantiation; in (2.91) and (2.92), the verbal arguments are not syntactically instantiated. Since Grammatical Relations are structurally defined in GB theory, the representations in (2.91) and (2.92), in which there is no NP dominated by VP or NP (uniquely) dominated by S, do not contain any categorial instantiation of Grammatical Relations.

2.2.9 Navajo Overt Nominals are in Argument Positions

I conclude this chapter with an investigation of the syntactic status of overt nominals in Navajo, which is considered by many to be a Pronominal Argument Language. I will argue that the available syntactic evidence mitigates against the hypothesis that Navajo overt nominals are adjuncts.

First of all, if overt nominals are in adjoined positions, then the pronominals in the argument positions are A-bar bound, and therefore we would expect them to behave as variables. For example, we would expect to find weak crossover effects, incorrectly predicting that a sentence like (2.95) should be ungrammatical. The overt nominal Jaan A-bar binds both the possessive pronoun bi and the pronominal in subject position, in violation of the bijection condition. However (2.95) is fully grammatical.

(2.95) Jáan_i bi_i-zhé'é yiyilitsá (= Jáan_i bi_i zhé'é [pro_i pro yiyilitsá])
 John his father saw
 'John_i saw his_i father'

Secondly, as Saito (1984) has pointed out the proposal that nominals

are not properly governed by the verb predicts that multiple questions should be ungrammatical in Navajo, since movement of two WH nominals to COMP would leave two adjunct traces. Although Saito's data seemed to indicate that multiple questions are ungrammatical in Navajo, informants of both Ken Hale and myself have said that this is not the case. According to these informants, Saito's example (2.96a), is indeed ungrammatical however the problem is not that there are two question words, but that both question words include a focus particle. Multiple focus is out in Navajo, but apparently multiple questions are grammatical, as shown in (c).

- (2.96) a) *Háí-lá ha'á'íí la yiyiítsé? 'Who saw what'
 who-prt what-prt saw
- b) *Jáan-ga' at'ééd-ga'yiyiítsé? John saw the girl.
 John-prt girl prt saw
- c) Háí-lá ha'á'íí yiyiítsé? 'Who saw what?'

Thus multiple question data provide evidence that nominals are not adjuncts in Navajo.

In sum, the proposal that Navajo nominals are adjuncts at D-structure would complicate the grammar and make incorrect empirical predictions.

Chapter 3

Pronominal Argument Infixes

In languages like Warlpiri or the Salish languages that Jelinek and her colleagues have considered to be Pronominal Argument languages, the surface position of the clitic pronouns is one to which the clitics might plausibly have moved at the level of PF. The AUX clitics in Warlpiri all appear in second position, and the clitics in languages like Lummi, one of the Salish languages studied by Jelinek and Demers (1985), are affixed to the right of the verb stem, a position to which they might plausibly have moved in the PF component.

(3.1) WARLPIRI:

Wawirri kapi-rna-0	panti-rni	yalumpu.
kangaroo	AUX: 1sgsubj-3sgobj	speak-NONPST that
'I will speak that kangaroo'		(Jelinek 1984.43)

(3.2) LUMMI:

- | | |
|--------------------------|-------------------|
| a. tečəl-sən | 'I arrived' |
| b. tečəl-sx ^W | 'You arrived' |
| c. tečəl | 'Someone arrived' |

(3.3) a. leŋ-n-oŋə s-s n 'I saw you'

b. leŋ-n-oŋə s-sx^W 'You saw me'
(Jelinek and Demers 1985.5)

However, there is one feature of Athabaskan in general and Navajo and Apache in particular that makes it quite problematic to extend Jelinek's version of the Configurationality Parameter to those languages: that is the fact that the prefixes which mark grammatical functions are apparently embedded in an unstructured string of various types of prefixes. Within the verbal complex, the order of prefixes is O...S...stem, so it is impossible to straightforwardly assign a verb-internal structure in which grammatical functions can be configurationally defined.

Furthermore, the verbal prefixes, in particular the subject prefixes, undergo various phonological processes which under traditional analyses have been presumed to take place in the lexicon, prior to insertion of the lexical item into syntax. In all traditional analyses of Athabaskan verbal morphology, the subject and object agreement prefixes seem to be inaccessible in the syntax, and thus unable to serve as verbal arguments.

Sandoval and Jelinek mention in a footnote certain problems in Apachean morphology which must be resolved in order for their proposal to work for those languages. I believe that this apparent inaccessibility of the pronominal affixes to the syntax is the problem they are alluding to. If we accept that abstract predicate-argument structure is universally hierarchical, then if it should turn out that these Navajo (and Apache) prefixes are not accessible in the syntax, we must conclude that in these languages the universal hierarchical structure is either projected via the Projection Principle exactly as

in English, yielding representations in which empty categories are licensed by rich morphology, or we must accept the dual representation hypothesis, and conclude that the unstructured string of words is mapped to an abstract Lexical Structure, rejecting Jelinek's theory of pronouns as arguments.

In fact, there is independent evidence that the Navajo prefixes which mark inflectional "agreement" must be infixes, that is, that these prefixes must be inserted into a discontinuous lexical item. In the next section, I will present a series of arguments to this effect. It should be noted that the view that Athabaskan agreement morphemes are infixes is quite at variance with the standard view of phonologists who have studied the phonological rules of Athabaskan languages. In particular, Rice (1982, 1983) and Hargus (1985) have argued, for Slave and Sekani, respectively, that the phonological evidence leans very heavily in favor of a model of word formation in which verbal prefixes are added sequentially, from the stem outwards. If such a sequential model is correct, then the problem of gaining access in the syntax to inflectional morphemes is a serious but potentially interesting one, which requires relating morphosyntactic structures to quite dissimilar phonological structures. I will return to a discussion of the issues involved once I have presented my arguments for an infixation model.

In the morphophonological literature on infixation, an 'infix' is generally defined as a morpheme which is inserted in some phonological environment, say, after the first syllable. The arguments which I will present motivate a view of Navajo whereby some of the prefixes must, at

some level, be external to a discontinuous lexical item, to be subsequently inserted into the affix string. The question of whether the insertion environment is phonological or not is left open, although the issue will be discussed at the end of the chapter. The actual execution of a descriptively adequate infixation model will have to await further research, and is no trivial task. An attempt to do so was made in Speas(1984), but this proposal was based upon certain assumptions about underlying representations which seem untenable, especially in Athabaskan languages other than Navajo.¹

If an infixation model for Navajo should turn out to be correct, then the serious problem with Apachean morphology which Sandoval and Jelinek mentioned may receive a simple solution: the pronominal argument morphemes may be in argument positions in syntax, and may simply move into the verb at Phonetic Form.

I will not draw this conclusion, however. As discussed earlier, such a proposal would make the wrong typological predictions, and would undermine the importance of the morphological properties of the affixes. Furthermore, as I argued in the preceding chapter, the syntactic tests indicate that NPs in Navajo are not in adjoined positions, but are themselves in argument positions. Thus, it appears that although the pronominal prefixes are accessible to the syntax,

1. This was brought to my attention by Leslie Saxon(p.c. and (1985). In particular, the infixation model which I proposed relied on the assumption that only one prefix was lexically listed between the object and subject positions. This assumption is false, even for Navajo.

they are not actually arguments as far as the Projection Principle is concerned.

After I have provided the arguments for infixation, I will show how this apparently paradoxical situation can be resolved without weakening the Projection Principle, by allowing a weak interpretation Lexicalist Hypothesis, along the lines of Baker (1986), who seems in fact to be returning to the original position of Chomsky (1970), that sub-parts of only some types of complex words are inaccessible in the syntax.² I claim that adopting this weak version of the Lexicalist Hypothesis allows us to account for the Navajo case by extending the definition of a well-formed CHAIN, such that the head of a CHAIN may occupy a theta-position while the tail of the CHAIN occupies a non-theta position, as long as the tail of the CHAIN is a sub-part of a word and hence not subject to the Projection Principle.

3.0.1 Navajo Prefixes and the Existence of Dual Representations

From the work of linguists such as Sapir and Hoijer (1945) Hale (1956), Stanley (1969), Kari (1973) and Young and Morgan (1981), a model of the Navajo verb has emerged in which it is possible in most cases to isolate individual prefix positions within the verbal complex. Yet

2. It is probably more perspicuous to say that Baker provides evidence that the debate over whether all inflectional (and derivational) morphology is all 'done in the Lexicon' ought to be resolved in favor of the position that it is not, a position which has been held all along by numerous morphologists.

most Athabaskanists still generally believe that Zellig Harris was at least partially right when he commented that "In addition to all the regular or partially regular alternations, there are so many individual replacements that a set of general rules for deriving phonemic forms, like those devised for Tubatulabal by Swadesh and Voegelin and for Menominee by Bloomfield, seems impossible here." (Harris, 1945:246³)

3.0.2 Interrupted Synthesis

The Navajo verbal complex is traditionally divided into between 8 and 10 position classes, as shown in (3.4). Each position class represents a set of morphemes which may be substituted in that position. The order of the position classes represents the (fairly) rigid order in which the affixes must occur.

(3.4)ADV	ITER.	DIST.	#	DIR	DEICTIC	ADV	MODE	SUBJ	CLASS	S T E M
		PL		OBJ	SUBJ					
1	2	3	#	4	5	6	7	8	9	

- 1 ADVERBIAL: Manner, direction, and other adverbial notions. Also indirect object pronoun may appear in this position.
- 2 ITERATIVE: An aspectual/adverbial prefix meaning "over and over" or "back again".
- 3 DISTRIBUTIVE PLURAL: Marks plural and also distributive 'each one separately'.
- # DISJUNCT/CONJUNCT BOUNDARY: Phonological boundary.
- 4 DIRECT OBJECT. Marks number and person of Direct Object.

3. Quote from Kari (1973:2).

- 5 DEICTIC SUBJECT: Subject is marked here if indefinite ("someone") or 4th person ("people in general" or "that person out of view")
- 6 ADVERBIAL: Like position 1 prefixes, these mark adverbial/aspectual notions.
- 7 MODE: Marks perfective, imperfective, progressive, or optative.
- 8 SUBJECT: Marks person and number of subject.
- 9 CLASSIFIER: In this position appears one of four morphemes marking +/- transitive and +/- active. While the paradigm seems productive for many verbs, it is often impossible to predict the argument structure of the verb from the shape of this morpheme.

Navajo stems are conjugated for aspect. foot (Kari 1979) and Leer (1979) maintain that this stem conjugation involves, diachronically, at least, the suffixation of aspectual morphemes to an abstract root. For example, Young and Morgan give the five stem alternants shown in (3.5) for the abstract root mas, which appears in various verbs having to do with globe-shaped objects (and subjects).

(3.5) -maas -máás -mas -maz -mááz

(3.6) shows a few examples of verbs which are derived from the root mas.⁴

(3.6) naasmaas "to roll around"
 binásmas "to roll it in it" (eg. a chicken leg in flour)
 shíla' niismas "to clench one's fist"

4. These examples are taken from Young and Morgan, so in this particular case, I am following their practice of translating the first person imperfective as a (citation) infinitive. When I am not citing their translations, I will translate these forms as 1st person imperfectives; eg., the first example means 'I am rolling around'.

(3.7) yásh'ti' " I am talking"
 (yásh+l+ti')
 1 8 9 stem

Some stems combine with different prefixes to yield words which differ substantially in meaning, such as those in (3.8).

(3.8) a) hi...ghal = arrive wriggling	b) ni...ghal = finish eating (of meat)
hinishghal "I arrived wriggling"	ninishghal "I finished eating it"
(hi+ni+sh+l+ghal)	(ni+ni+sh+l+ghal)
6 7 8 9 stem	6 7 8 9 stem
	(Young and Morgan 1980:419)

Other stems combine with different prefixes to yield words which are different but whose semantic relationship is more transparent.

(3.9) a) nishdaah 'I am sitting down' yiishdaah 'I remain behind'

Various phonological rules serve to obscure the morpheme-by-morpheme analysis of many complex words. In (3.10 a), the glide y does not surface and the vowels have been lowered by phonological rules. Note that in (3.10b), a metathesis rule has switched the order of the morphemes in positions 5 and 6.

(3.10) a. dínéeshdaat
 di+ni+yi+sh+daat
 1 6 7 8 stem
 'I will sit down'

b. dízhnóodaat
 ji+di+ni+yi+daat
 5 6 7 8 9 stem
 'He (4th p) will sit down'

(Young and Morgan 1980:658)

Nonhead: the highest left branch of a word
(ibid.:261)

Clearly this definition cannot capture the lexical relatedness facts in Navajo unless we give the definitions of head and nonhead of a word a more abstract interpretation. If we applied Williams definitions directly to Navajo, we would make the incorrect prediction that pairs like (3.13a and b), which differ only in stem, are lexically related while pairs like (3.14a and b), which differ only in subject morpheme, are not related, since the subject morpheme is neither the rightmost morpheme nor the morpheme on the highest left branch of the word.

(3.13) a. distsóós 'I start carrying it (flat flexible obj)'
 (di+sh+l+tsóós)

 b. dists'q̣q̣d 'I pull it taut'
 (di+sh+l+ts'q̣q̣d)
 (ibid.:333)

(3.14) a. yáshti' 'I am talking'
 (yásh+l+ti')

 b. yání'ti' 'you are talking'

The intuition for Navajo is that the words in an inflectional paradigm such as those in (3.15) are lexically related, while those which differ in non-inflectional morphemes are not necessarily related.

(3.15) so...di...l...zin	'pr ay'	sodiszin 'I pray'
		sodilzin 'you pray'
		sodilzin 's/he prays'
		sozhdilzin 's/he(4th p) prays'
		sociilzin 'we pray'
		sodolzin 'you(2) pray (ibid.:689)
di...ʔ...lid		dishʔid 'I burn it'
		díʔid 'you burn it'
		yidiʔid 's/he burns it' (ibid.:337)
kée...ha...t'í		kéeʔasht'í 'I reside'
		kéeʔót'í 'you reside'
		kéeʔat'í 's/he resides'
		kéeʔojit'í 's/he(4thP) resides'
		kéeʔwiit'í 'we(2) reside'
		kéeʔólit'í 'you(2) reside'
		kéeʔahwiit'í 'we(pl) reside'
		kéeʔahojit'í 'you(pl) reside'
		kéeʔahat'í 'they reside'
		kéeʔahojit'í 'they (4th p) reside'

The simplest way to express the lexical relatedness holding among members of paradigms such as the above would be to claim that there exists an abstract representation of a Navajo word in which the discontinuous stem is listed without inflectional morphemes and the

inflectional morphemes are inserted into the discontinuous stem. Under such an analysis, the inflectional affixes would be outside of derivational morphemes in the abstract representation. If we do not derive these words through infixation, then we must claim that speakers of Navajo store huge paradigms for each lexical entry. This would require us to believe that the lexical component of the Grammar of Navajo is vastly different from the lexical component of English, where it is reasonable to suppose that lexical items are stored in uninflected forms and that the rules of inflectional morphology apply productively. Since the position and form of the inflectional morphemes in the Navajo verb are invariant, the hypothesis that Navajo speakers simply store huge paradigms seems to be missing an important and clear generalization. If, on the other hand, we claim that Navajo verbs are derived by means of infixation, then the lexical components of English and Navajo would differ minimally. Lexical relatedness in Navajo would be captured because uninflected words could be stored independent of the inflectional morphemes, which are inserted productively as infixes. Under such an hypothesis, lexical relatedness could be universally defined in terms of structural properties, along the lines suggested by Williams.

It should be noted in addition that the prefixes in the discontinuous verbs in (3.15) are all of the type which Sapir and Holjler (1967) called "thematic", they do not have any meaning of their own and do not attach productively to verb stems, rather the discontinuous combinations shown in the examples seem to be assigned a meaning as a whole.

3.0.3.2 Mode Choice and D-shift

The second argument in favor of infixation in Navajo is a morphosyntactic one having to do with a two processes which are known in the Navajo literature as Perfective and imperfective mode choosing and d-shift. First I will introduce these phenomena, and then I will show how a perspicuous account of them is only possible in an infixation model.

When a Navajo verb is inflected for the perfective or imperfective, the morpheme which so marks the verb appears in position 7 in the prefix complex⁶, and may be one of three different morphemes. The three forms for the perfective, which I will focus on, are si, yi, or ni. Many of the adverbial prefixes occur with only one of these allomorphs; these prefixes are called "mode choosers". Below are some examples of prefixes which always select a particular mode prefix. Some prefixes which choose si-perfective are shown in (3.16a), some that choose yi-perfective are shown in (3.16b), and some that choose ni-perfective are shown in (3.16c). In each case, the position in which the mode chooser occurs is indicated. Most, but not all, of these forms are from Kari (1976:220). I have underlined the mode

6. Many descriptions of the verbal prefixes add another position between position 7 and the subject for the perfective marker -i- (or more specifically, the perfective prefix is analyzed as a compound prefix). Reichard (1951), Stanley (1969), Hale (1972) and Kari (1976) follow this practice. But cf. Rice (1985) for arguments that there is only one mode position.

chooser and the mode marker, but have not provided a complete morphemic breakdown for these examples.

(3.16) a. **si- perfective**

pos 1: na "around about"

nisétt{ 'I carried him around'
(na+si+sh+t+t{)

ha 'after,
in pursuit of'⁷ hashinilzhee 'you went hunting'

pos 6: di 'begin' deezbaa 'he went to war'

ni 'terminative' neesk'ol 'he blinked'

b. **yi- perfective**

pos 1: na 'down'

néíníne 'you dropped it'

ha 'up and out' hááged 'I dug it up'

pos 6: yi (thematic)

yiiitsé 'I saw it'
yiniitsé 'You saw it'
yiyiiitsé 'S/he saw it'

c. **ni- perfective**

pos 1: ch'í 'out
horizontally'

ch'ínítbááz 'I drove it out'⁸

k'í- 'apart' k'ííních'iizh 'he sawed it apart'

pos 6: dí 'closure'

bidadíní' é 'I put it on it'

hi 'seriative' hinishghal 'I arrived wriggling'

7. Kari cites this prefix as the ha which means 'upward', but Ken Hale informs me that ha 'upwards' only takes yi perfective, and that the prefix in the word listed here is actually ha 'after; in pursuit of'.

8. Kari cites this form as 3rd person singular, but this is probably a typographical error.

The question to ask in an attempt to explain the selection of a particular perfective morpheme is whether the three mode variants are synonymous allomorphs or whether each has some semantic properties which may be selected by particular prefixes. Although the semantic differences among the mode prefixes are not obvious to the non-native speaker, most recent analyses indicate that the mode markers may be semantically classified. Young and Morgan (1980) say that ni is terminative, yi is completive and si is stative. Krauss (1969) classifies ni as meaning 'to a point' (completive), yi as 'from a point' (inceptive) and si as unmarked.

(3.17) Young and Morgan (1980):	Krauss (1969):
ni terminative	ni 'to a point', completive
yi completive	yi 'from a point'; inceptive
si stative	si unmarked

We may remain neutral on the issue of whether these three morphemes designate clear semantic classes and say that a prefix which chooses a particular perfective or imperfective mode morpheme selects a verb which is marked with one of these (semantic or morphosyntactic) features. However, notice that we would be failing to capture the direction of selection if we simply proposed that adverbial prefixes were stored in the lexicon with an indication of whether they were allowed to go on verbs which were in some particular mode. Consider for example, the prefix ch'í, 'out', which chooses the ni-perfective, as in ch'ín.í íh'ááz 'he drove it out'. It is not the presence of the prefix ni which determines that ch'í will be prefixed. Rather, once ch'í is prefixed to the stem, we then know that the perfective mode marker must be ni. That is, adding the prefix ch'í to a verb derives a verb that is of the

hadasiicha 'we(3+) cried out'
 (Kari 1976:223)
 *hadaiicha

c) k'íiníich'iizh 'he sawed it apart'
 k'íidei_{zh}ch'iizh 'they sawed it apart'
 (Kari 1976:223)
 *k'íideiníich'iizh

d) ni_{oo}łbááz 'you(2) parked it'
 nda_{soo}łbááz 'you (3+) parked it'
 *nda_{noo}łbááz

The phenomenon of da-shift clearly shows that Navajo verbs cannot simply be derived from the stem outwards, using diacritic (or semantic selection) features on the lexical entries of prefixes to get the cooccurrence restrictions to come out right. If the prefixes had lexical entries like those in (3.20) and were attached to the verb in sequence from the stem outward, the prefix ch'í could never be put on a plural word, since the plural prefix, which goes on si perfectives, would already be attached at the time that ch'í would be attached.

(3.20) ch'í { da | ha |
 +ni +si +yi

Instead, it seems to be the case that when da is added, the verb is changed to one which is only compatible with the si-perfective. Recall that da is a marker not only for plural number, but also for distributive ('each one separately'). It is plausible to suppose that this distributive aspect creates the semantic environment into which the si-perfective, which, according to Krauss(1969), goes on the verbs which are neither specifically inceptive nor specifically

completive, may be infixated.

The crucial piece of evidence that Navajo verbs must be formed via infixation rather than, say, having the prefixes combine freely, with filters ruling out forms like *k'ídeiních'iizh on semantic grounds is the fact that the position 6 and position 1 mode choosers which have no independent meaning and must apparently be part of a discontinuous listing in the lexicon are all exceptions to d-a-shift.⁹ Examples are shown in (3.21) and (3.21).

(3.21) POSITION 6:

a) baa díní' é' 'I gave it up to him'
to-him 6 7(8) stem

baa dáiniit' é' 'we gave it up to him'
(Young and Morgan 1980:326)

*baa dáleet' é'

b) nininiisht' é' 'I lay my head down'
1 6 7 8 stem

ndaniiniit' é' 'we lay out heads down'

*ndanisiit' é' (ibid.:647)

c) nininítkaad 'I herded them to a point'
1 6 7 8 stem

ndaniiniilkaad 'we herded them to a point'
(ibid.:647)

*ndanisiilkaad

d) hinishghal 'I arrived wriggling'
6 7 8 stem

dahiniighal 'we arrived wriggling'
(ibid.:419)

9. The sources cited give only the grammatical forms.

*dahi siighal

(3.22) THEMATIC POSITION 1:

- a) yáátti' 'He talked'
yáátti' 'they talked' (yi)
*yáaasti'

These data show that a simple semantic compatibility account cannot be right, since the prefixes which are exceptions to da-shift are just those which must be listed in the lexicon as part of a discontinuous word. Thus, we find a minimal difference between word like yaalti', where the position 1 prefix ya- does not occur on other words, and those like k'iinich'iizh, where the prefix has an independent meaning and is found on other words. Da-shift does not occur with the prefix which must be idiosyncratically listed with its stem. The meaning of the discontinuous word as a whole is not a factor in the word's status as an exception to da-shift.¹⁰

(3.23) a. DA-SHIFT:

- k'íinich'iizh 'he sawed it apart'
k'íidei_zhch'iizh 'they sawed it apart'
*k'íideiních'iizh

cf. k'ínígizh 'I cut it in two'
k'íníthaal 'I chopped it off'

b. NO DA-SHIFT:

10. It should be noted that it is quite difficult to find examples to test the hypothesis that thematic position 1 prefixes are a regular class of exceptions to Da-shift. This is because the number of these prefixes which both do not already choose si- perfective and do not appear in conjunction with a position 6 prefix are limited.

yáá'ti' 'He talked'

yáá'á'ti' 'they talked' (yi)

*yáaasti'

The data presented so far cannot be accounted for under a model in which Navajo verbs are built up by sequential affixation from the stem outward. They receive a quite simple account if we make the following assumptions:

1. The basic lexical entries of a Navajo verb may include thematic prefixes (i.e. those with no independent meaning).
2. Inflectional morphemes in Navajo are infixes.
3. The feature which determines which mode morpheme will be inserted is marked only once. When a prefix is added to a verb, it influences mode choice only if mode choice is not already indicated. In other words, the mode choice features of a prefix are added only if the prefix is being added to a verb which is unmarked for mode choice features.
4. Navajo verbs are derived by adding affixes in the following (hierarchical, not linear) order:

[mode [da [adverbial prefixes [stem+thematic prefixes]]]]

Thus, we have lexical entries like the following, which include diacritics showing which features they add which affect mode choice:

(3.24) [yá...ti']
 [+yi]
 da adds [+si]

- (3.27) a. Shí naashnish.
 I lsg-work
 'I am working'
- b. Shí dóó aashiiké ndeiilnish.
 I and boys pl-lsg-work
 'The boys and I are working'
- c. Shí aashiiké bił ndaashnish.
 I boys with-them pl-lsg-work
 'I am working with the boys'
- d. Shí yisháát.
 I lsg-walk:sg
 'I am walking along'
- e. Shí dóó aashkii yit'ash
 I and boy lsg-walk:du
 'The boy and I are walking along'
- f. Shí aashkii bił yish'ash
 I boy with-him lsg-walk:du
 'I am walking along with the boy'

In these sentences, there are three different methods of marking the number of participants in the verbal event: the pronominal agreement marker in the verb may be singular, dual or plural, the verb stem may be singular, dual or plural, and the morpheme da may appear in the verb.

Notice that if all three types of number marking are considered to be agreement marking, the verbs in the comitative constructions (sentences c and f) above contain conflicting number features. In c, the subject morpheme is 1st person singular, yet the plural morpheme da appears,

marking the subject as plural.¹² In sentence f, the stem is dual, yet the subject morpheme is 1st person singular.

This conflict may be resolved by distinguishing between true grammatical agreement and number features which have to do with the number of participants in the event signified by the verb. For example, in sentence f, where the stem is dual while the subject morpheme is singular, we may consider the dual marking in the stem to be a semantic marking, indicating the nature of the walking event. A singular walking is a walking event undertaken by one person alone, while a dual walking is a walking involving a pair of walkers. In sentence f, the singular subject is participating in a pair-wise walking. Thus, the ill-formedness of a sentence like (3.28 a) is semantic, parallel to the ill-formedness of the English sentences (3.28b-d). In all of the sentences in (3.28), the verb simply happens to be a predicate true only of events involving two participants.

- (3.28) a. *Shí yish' ash.
 I 1sg-walk:du
 b. *I met.
 c. *The meteor collided.
 d. *John kissed.

If we treat the distributive plural morpheme da as a grammatical agreement marker, then we have no explanation for the agreement conflict manifested by sentence (3.27)c, where da indicates a plural subject while sh indicates a singular subject. On the other hand, if

12. the stem -nish is not marked for number.

we do not consider da to be a grammatical agreement marker, then we can say that the addition of the morpheme da changes the verb from one involving a single participant to one involving multiple participants. Notice that da may be added to a stem which is already marked as plural; in this case, da adds distributive aspect.

(3.29) a. Hooghan bich'j' néíikáh
 hogan toward-it lpl-walk:pl
 'We (3+) are walking back toward the hogan in a group.

b. Hooghan bich'j' ndeíníikááh
 hogan toward-it dā-lpl-walk:pl
 'We (3+) are walking back toward the hogan as a
 (scattered) group of individuals.

Hooghan bich'j' ndeíníidááh
 hogan toward-it dā-lpl-walk:sg
 'We (3+) are walking one at a time back toward the hogan.
 (Young and Morgan 1980:160)

These data suggest that da should be treated as an adverbial or aspectual morpheme rather than an agreement morpheme. Thus, we have independent (although indirect) support for our contention that da is already present in the word at the point at which other inflectional morphemes (such as the perfective mode) are inserted, since da patterns with stems and adverbial morphemes rather than with inflectional morphemes with respect to agreement.

3.0.3.3 Ni-absorption

The final argument which I will present in favor of an infixation account of Navajo verbal morphology is a phonological argument, involving the rule known in the literature as ni-absorption.

Kari (1976) states the rule as in (3.30).

(3.30) CV + ni [_[A12] ---> CV' (Kari 1976:245)

To state the rule in words, when ni occurs between a (conjunct) open syllable and the stem,¹³ ni is realized as a high tone on the vowel in the open syllable. Note that the rule applies only when both the ni and the environment syllable are conjunct prefixes; ni absorption does not apply to disjunct prefixes.

My argument involves the fact that position 6 ni morphemes are exceptions to ni-absorption. I will show that this fact can be accounted for under the assumption that position 6 (adverbial and aspectual) morphemes are present in a word prior to the insertion of inflectional morphemes.

There is a great deal of homophony among the verbal prefixes. Morphemes of the form ni may show up as any of the following:

- (3.31) position 8: 2sg subject
position 7: imperfective and perfective mode
position 6: adverbial and thematic
position 4: 2sg direct object
position 1: 2sg indirect object, cessative aspect

The rule given by Kari predicts that whenever a morpheme ni which is one of the conjunct prefixes appears with no other prefixes between it

13. More specifically, the bracket in the rule refers to what Kari calls the 'null environment', that is, the stem with its classifier.

and the stem, it should be 'absorbed' by a conjunct prefix to its left. However, it turns out that position 6 ni does not undergo ni absorption, as shown by the following examples, where second person subject position 8 ni contrasts with position 6 ni.¹⁴

(3.32)

a) nishteéh 'I lie down'
 ni+sh+teeéh
 6 8 stem

níteeéh 'you lie down'
 jiniteéh 's/he lies down'
 *jíteéh
 (Young and Morgan 1980:662)

b) nistséés 'I extinguish it'
 ni+sh+í+tséés
 6 8 9 stem

nítséés 'you extinguish it'
 yiniteés 's/he(3s) extinguishes it'
 jiniteés 's/he(4s) extinguishes it'
 *yítseés *jiltsees
 (Young and Morgan 1980:657)

c) nis:óód 'I drive it' (anim)
 ni+sh+yóód
 6 8 stem

níyóód 'you drive it'
 yinyóód 's/he(3s) drives it'
 jinyóód 'sh/e(4s) drives it'
 *yíyóód *jiyood
 (Young and Morgan 1980:657)

Note that although these examples show only the second person subject undergoing ni-absorption, the other paradigmatic prefixes undergo this rule as well, as we see in (3.33), where the ni-imperfective mode marker is absorbed.

(3.33) jígááh 'S/he (4th person) arrives'
 (ji+ni+ghááh) (ibid.:657)

Let us examine the first example more closely. The verb which means 'lie down' is a discontinuous one, ni...teeéh, which includes the prefix

14. The cited sources give the grammatical forms only.

with only 3 exceptions¹⁵ the vowel in a conjunct prefix is always [i]. Furthermore, there exists an independently needed rule of epenthesis in Navajo. Therefore, Wright and Spears proposed that all Navajo conjunct vowels are epenthetic, so the underlying representation of a conjunct prefix does not include vowels. The prefix ni, then, would be underlyingly

(3.35) n
 |
 C

We may now state two rules: ni-absorption and epenthesis. Ni-absorption only applies to morphemes which have not yet undergone epenthesis.

(3.36) ni-absorption: n epenthesis:
 | Ø ----> i / C__C
CV + C| ----> CV'

If we suppose that position 6 ni morphemes are a basic part of the lexical item while inflectional affixes are infixes, then the above

15. Ken Hale, p.c., informs me that these three are probably not exceptions either. These are the ho- (position 4) areal prefix, which is probably underlyingly hwi-, the optative o- (position 7), which is probably underlyingly wi (although this is not as clear) and the indefinite 'a- (position 5), which is probably underlyingly 'i.

rules, applied cyclically, yield exactly the right results.¹⁶

(3.37)	ni + ni [teeh 6 8		ji + ni [teeh 5 6
	n [teeh	UNDERLYING	n [teeh
	-----	NI-ABSORPTION	-----
	ni [teeh	EPENTHESIS	ni [teeh
	ni n [teeh	AFFIX SUBJECT	j ni [teeh
	ni' [teeh	NI-ABSORPTION	---- [teeh
	-----	EPENTHESIS	ji ni [teeh
	ni'teeh	OUTPUT	jiniteeh

3.0.3.4 Summary

The model which emerges from the arguments which we have given in favor of infixation in Navajo is one in which the words are built up in the following way: First, the stem plus thematic prefixes are composed. Then, the distributive aspect (and probably other aspects) is added. Next, productive adverbial prefixes are added, and finally, inflectional morphemes are added. It is worthwhile pointing out that this model is quite parallel to the original description of the Navajo

16. I am assuming here that the mode morpheme is inserted before the subject. This may not be right, but at this point I do not know of any evidence against such an assumption.

verb given by Sapir and Hoijer in 1967.

(3.28) [thematic + stem] THEME
[distributive [thematic + stem]]
adverbial[distributive [thematic + stem]] BASE
paradigmatic[adverbial [distributive [thematic + stem]]CONJUGATED
WORD
(cf. Sapir and Hoijer 1967)

I have argued that various phonological, semantic and syntactic facts are best expressed if the derivation of a word proceeds such that the morphosyntactic structure has the inflectional morphemes on the outside of the word, while the phonological structure has these same affixes as infixes within the word. The question which now arises is this: how do the infixes get inserted? That is, what is the nature of the infixation frame?

3.0.3.5 Evidence for Concatenative Phonology

In a recent paper Hargus (1986) has pointed out that the majority of the arguments presented in the literature in favor of an infixation account of Navajo word formation are morphosyntactic rather than phonological in nature. She presents two pieces of phonological evidence which appear to show that the prefixes must be added in the sequence ROOT then SUBJECT then CONJUGATION then MODE. In other words, the rules of phonology seem to operate from the stem outward, in sequence.

In this section, I will examine one of Hargus' evidence, showing that

UNROUNDING, THEN INFIX SUBJECT:

<u>Subject=ji</u>	<u>sSubject=iid</u>
ho + [ɬdéeéh]	ho + [ɬdéeéh]
unrounding:	
ha + [ɬdéeéh]	ha + [ɬdéeéh]
infix subj:	
*hajiɬdéeéh	*heiɬdéeéh (ə--ɬe , d drops out)

With a derivation from the stem outward, the right result can be achieved:

(3.40)	[ɬdéeéh]	[ɬdéeéh]
add subj:	[iid- [ɬdéeéh]]	[ji- [ɬdéeéh]]
add ho-:	[ho- [iid- [ɬdéeéh]]]	[ho- [ji- [ɬdéeéh]]]
unrounding:	-----	-----
diphthongization, vowel deletion, l-voicing, d-deletion:		
	hwiɬdéeéh	hojiɬdéeéh

To summarize this argument, Hargus is saying that the subject prefix bleeds the unrounding rule, and must therefore be present when the rule applies.

This argument is inconclusive though. Notice that only the fully syllabic subject prefixes bleed unrounding. The consonantal 1st person singular does not block the rule. In the paradigm given, we have no evidence that unrounding is a rule which must apply as soon as ho- is added. That is, it might be a postlexical rule which applies after the word has been put together, unrounding a vowel which is in the penultimate syllable of the word. Stems in Navajo are almost always monosyllabic, so such a view is plausible. Hargus considers this counter argument, and rejects it on the grounds that there are a few

bi-syllabic verb stems. She predicts that if ho- is affixed to one of these stems along with a non-syllabic subject, ho- will undergo unrounding. She cites a noun which appears to be deverbal as evidence that her prediction might be true.

- (3.41) Some disyllabic stems from YM 408 ff. (taken from Hargus 1986:6)
- | | |
|----------|----------------------------|
| -ch'íídi | 'to be few in number' |
| -gháí | 'to be nearby, close' |
| -'ídi | 'to be brittle, fragile' |
| -zhóí | 'to be soft, pliable' |
| -ts'íli | 'to be clear, transparent' |
| -yázhí | 'to be little' |
| -zíli | 'to be warm, tepid' |
| -k'ázi | 'to be cool (an object)' |

- (3.42) hak'az 'coldness'

Hargus theory predicts that ho plus disyllabic stem will become ha + stem. The postlexical analysis predicts that ho + monosyllabic stem becomes Həstem, but that ho+disyllabic stem remains ho+stem. Hargus noun example is evidence for her account only if the derivation of the word is:

ho+k'ázi ---> hak'ázi ---> hak'az

That is, her argument is valid only if the ho to ha rule does not apply in nouns. This assumption is suspect, since we find many nouns of the form ha+syllable(stem) (and ho (hi tone) +syllable) but none whatsoever of the form ho+syllable (i.e., no disyllabic nouns whose first syllable is ho-).

- (3.43) həshk'əən 'yucca fruit, banana, fig, date'
- | | |
|---------|--------------------------|
| hastáí | 'six' |
| hastiin | 'man' |
| hók'áí | 'high point, high place' |
| hooghən | 'hogan, home' |
| hoodzo | 'zone, boundary line' |

I am making this observation based on a search of the YM dictionary. Unless some crucial forms are missing from there, we must conclude that unrounding is a general rule that applies to unround any vowel which shares penultimate syllable with a velar.

o ---> a / velar --- syllable##

The second phonological argument which Hargus presents has to do with a distinction between paradigmatic ni prefixes in position 7 and ni prefixes from position 6. She points out, I think correctly, that the subject cannot be inserted after the paradigmatic ni prefix. This may provide evidence that all inflectional morphemes must be inserted at once, but it does not argue against the account which I gave for the rule of ni-absorption above.

3.0.4 Infixes and CHAINS

I have argued in the preceding section that various phonological, semantic and syntactic facts in Navajo are best expressed if the inflectional clitics are infixes, in the sense that there must exist a representation in which they are outside of the discontinuous theme. In the model which these arguments suggest, the phonological and semantic word formation rules can be viewed as working in unison; for every rule which augments the phonological form word through infixation, building a linear string, there is a rule which augments the semantic form of the word through the attachment of a morpheme, building an abstract structure.

The question now arises of how to get the infixes in the right positions in the phonological string. That is, what are sorts of insertion environments will yield strings of morphemes in the correct linear order? It is crucial that we constrain the possible infixation frames, otherwise the proposal that some languages have infixes while others do not will be rendered vacuous.

Consider the Athabaskan language learner, hearing verbs and trying to extract the regularities. There are three possible theories of how the morpheme order is learned:

1. The morpheme order is totally random, and the language learner simply memorizes the position classes, learning some sort of order template. In this case, the subject clitic, for example, would have a lexical entry including its syntactic, semantic and phonological features, and a diacritic indicating its relative order in the template.
2. The morpheme order follows from some general morphosyntactic or morphosemantic principles, which are available to the language learner as part of universal grammar. In this case, the lexical entry of a prefix would include only its syntactic, semantic and phonological features.
3. The infixes have phonological insertion frames, the the task of the language learner is to learn the correct phonological insertion environment for each morpheme. In this case, also, the lexical entry of the prefix would include only syntactic,

semantic and phonological features, with one of its phonological features being its infixation frame.

The first hypothesis is not totally implausible, and is essentially the view that has traditionally been held about Athabaskan morphology. We know that humans have a relatively large capacity for memorization.

Memorization of this system, however, would require a substantially greater amount of straight memorization than any other subsystem of the grammar of any language so far studied. Furthermore, given that there are metathesis rules which switch the order of morphemes, it is not clear how the order would be learned from the available input. Also, as pointed out in Speas(1984), there is the problem of the status of a memorized template as a linguistic device.

The second hypothesis would be based on the growing body of evidence that the order of morphemes is not simply random, but mirrors the order of grammatical processes indicated by these morphemes. Gerds(1981) expresses this generalization as the Satellite Principle, and Baker(1985) proposes the similar Mirror Principle:

(3.44) SATELLITE PRINCIPLE

... affixes are ordered from the root outward (i.e. suffixes are ordered from left to right and reflexes from right to left) according to the order of the syntactic strata, as follows: initial to final strata¹⁷, and downstairs clauses to upstairs clauses.

(3.45) MIRROR PRINCIPLE

Morphological derivations must directly reflect syntactic

17. Gerds was working within the framework of Relational Grammar, in which strata correspond to level of derivation.

derivations (and vice versa). Baker (1985a:375)

Both Gerds and Baker state explicitly that these principles are intended to apply to derivational morphology, and that it is not at all clear how they might be extended to inflectional morphology. The sorts of regularities that they observed in derivational affix order are not obviously found in inflectional affix order, as we can see by examining the affix orders from several other Athabaskan languages:

(3.46) Ahtna (Kari 1979)

Adverbial
Iterative
Incorporated stem
Distributive
Direct Object
1 pl. Subject
Thematic
Indefinite Object
3 pl Subject
Area
Serialive
Conative
Inceptive
Gender 1
Gender 2
Completive
Transitional
s-perfective Negative
Mode
Perfective
Subject
Classifier (voice and transitivity)
STEM (=root+suffix)

Slave (Rice 1985)

Indirect Object
Postposition
Adverbial
Distributive
Customary
Incorporated stem
Number
Direct Object
Deictic Subject
Thematic
Aspect

Conjugation Marker
Mode
Subject
Classifier (voice and transitivity)
STEM

Sekani (Hargus (1985))
Postposition
Adverbial
Incorporated N or V
Distributive
Reversative
Inceptive
Direct Object
Subject
Derivational
Conjugation
Mode
Subject
Classifier (voice and transitivity)
STEM

Chiricahua Apache (Hoi j.er 1946)
Clitic
Adverbial
Indirect Object
Adverbial
Iterative
Distributive
Direct Object
Deictic
Adverbial
Tense/Mode
Subject
Classifier
STEM

Chipewyan (Li 1946)
Postposition
Adverbial
Iterative
Incorporated Noun
3P Subject
Direct Object
Modal
Aspect
Subject
Classifier
STEM

However, just because the affix orders vary somewhat and it is difficult to discover the regularities does not mean that the order is random. In fact, there are various indications that the order is not random. For instance, it has been observed since the first studies of these morphological systems that the prefixes which are located closer to the stem seem in some intuitive sense to be notionally closer as well; the closer to the stem a prefix is the more likely it is to be obligatory.

Furthermore, Speas(1984) observes that in Navajo, at least, there is essentially one position on each side of the disjunct/conjunct boundary where lexically listed prefixes occur,¹⁸ and that the order of the pronominal agreement markers in the prefix complex is in just the mirror image of order that we would expect to find them in if they occupied argument positions. These and other regularities suggest that the prefix order is probably not random.

In Speas(1984), it was proposed that all infixes have a phonological insertion frame, and infixation takes place in ordered levels, serving to modify an underlying phonological template. As I mentioned earlier, this proposal needs extensive discussion if something like it is to work. In particular, a thorough analysis of Navajo syllable structure might give insight into a correct set of phonological insertion

18. This generalization would more accurately be stated in terms of adverbial and aspectual lexically listed prefixes, since there are words which seem to have lexically listed direct objects and perhaps others.

frames.

Thus, the issue of the correct insertion frames for Athabaskan infixes remains open. What is clear, however, is that there must exist some representation for Navajo verbs in which the inflectional morphemes are outside of the stem and adverbial morphemes. Somehow, we must be able to relate this abstract structure to the string of prefixes plus stem.

(3.47) STRING OF MORPHEMES

ABSTRACT STRUCTURE

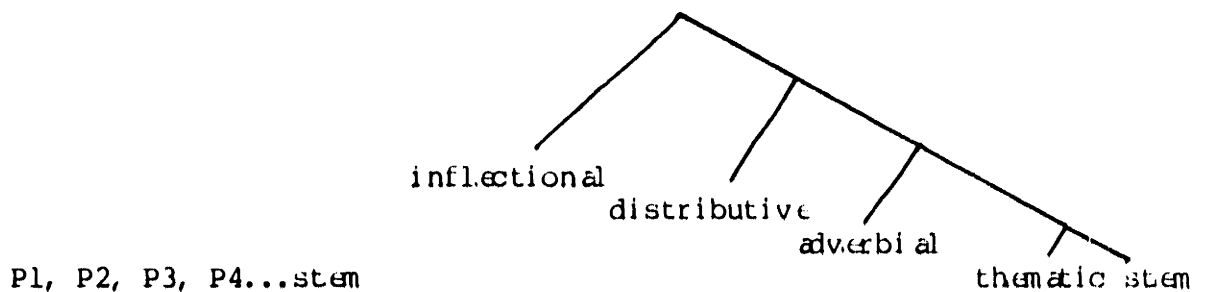

Diagramming the problem in this way brings out the striking parallel between the problem that we find in Navajo morphology and the problem of Configurationality in syntax. Hale's dual representation hypothesis is precisely the hypothesis that at the syntactic level, abstract structure is to be distinguished from the (possibly structured) string of phonological words.

3.0.5 Argument Positions

In this section, I would like to propose a solution to the apparently paradoxical status of the Navajo prefixes. On the one hand, they seem to be hierarchically structured outside of the verb theme at some level of representation, while on the other hand, the evidence indicates that

they are not syntactic arguments.

I claim that adopting this weak version of the Lexicalist Hypothesis allows us to account for the Navajo case by extending the definition of a well-formed CHAIN, such that the head of a CHAIN may occupy a theta-position while the tail of the CHAIN occupies a non-theta position, as long as the tail of the CHAIN is a sub-part of a word and hence not subject to the Projection Principle.

Baker (1986) considers the problems posed for the Strict Lexicalist Hypothesis by certain morphological processes which appear to affect syntactic representations. He applies to morphology the suggestion of Grimshaw (1985) that a 'component' should be taken to be a set of rules or representations defined over a certain vocabulary and governed by principles of a certain type rather than a set of rules or operations which act as a block in the organization of the grammar. By viewing the morphological 'component' in the way that Grimshaw suggests, it is possible to give a modular account of those morphological rules which seem to apply 'in the syntax', without abandoning a form of the Lexicalist Hypothesis. Specifically, we may adopt a strict form of modularity whereby the principles from component X may not refer to properties from component Y. For example, principles like those in (3.48) would be impossible.

(3.48) a. * X must c-command its trace if X is a suffix.

b. * [X+Y] is a valid compound structure only if
X assigns a theta role to exactly one NP.

(Baker 1986:18)

Most of Baker's case studies have to do with derivational morphology, but he makes several points about the implications of his work for inflectional morphology. First, the incorporation phenomena which he studied extensively in Baker (1985) suggest that "canonical inflectional morphology is added to words in or after the syntax, rather than before." (1986:18) Thus, his data support the view of, e.g. Anderson (1982) that inflection is separate from derivation, contra the views of Lieber (1980), Bresnan (1982) and Williams and diSchullo (1985) that lexical items are inserted into the syntax with all inflectional morphemes attached.

I will adopt the position that the phonological and morphological properties of any lexical item are separate from its syntactic (and semantic) properties. The syntactic properties of any morpheme or lexical item include both its syntactic (case, theta, etc) features and its category. In standard analyses, a morpheme (or lexical item) with features of person, number, case, etc. may be either an NP (pronoun) or an inflectional morpheme. That is, the features of a morpheme are independent of its category label. An inflectional morpheme may appear either attached to some other category or in a head INFL.

With this in mind, we may propose a solution to the apparently paradoxical situation in Navajo, whereby overt NPs behave as though they were in argument (rather than adjunct) positions and pronominal arguments are sub-parts of a word, yet NPs may be freely omitted and the prefixes which mark subject and object agreement are outside of the verb theme in some representation.

To begin with, let us say that the representation in which the agreement prefixes are outside the word is the morphological representation. Although this representation may have internal structure, it does not express syntactic properties such as argument, theta role, etc. However, nothing in current theory forbids the principles of one component (in the Baker/Grimshaw sense) from being stated in such a way as to interpret representations in another component. To take a simple example, the semantic principles which interpret the scope of quantifiers do so on the basis of the structural configuration in which they find those quantifiers.

Now consider the well-formedness conditions which Chomsky (1986a) claims that syntactic CHAINS are subject to, repeated here as (3.49):

(3.49) CHAIN CONDITION:

If $C = (a_1, \dots, a_n)$ is a maximal CHAIN, then a_n occupies its unique theta position and a_1 its unique Case-marked position. Chomsky (1986a:137)

If the morphological properties of a lexical item are independent of its syntactic properties, then we predict that a sub-part of a word will be free to form a CHAIN with any other lexical item, as long as no independent principles are violated.

The condition on CHAINS disallows any CHAIN in which the head is in a theta position as well as any CHAIN in which tail is in a case marked position. As Chomsky (1985a) discusses at some length, the CHAIN Condition follows from the interaction of independent principles of the Grammar, in particular from the Theta Criterion and the Visibility Condition.

Since the CHAIN Condition follows from independent principles of the Grammar, if there were some circumstance under which a CHAIN could be formed which obeyed all other principles and in which the head was in a theta position while the tail was in a case position, nothing would rule this CHAIN out.

I suggest that this is precisely the sort of CHAIN which is formed when an agreement sort of antecedence relation holds between an argument position and a sub-part of a word. Thus, in a Navajo sentence like (3.50), which has the structure shown in 3.50b), a CHAIN is formed between the pronominal agreement marker, which is morphologically within the verb.

(3.50) a. At'éeéd ashkii yizts'qs
 girl boy yi-Ø-kissed
 obj-subj-stem

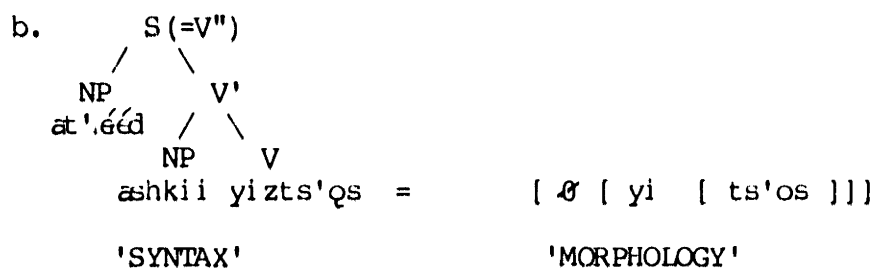

(3.51) CHAINS. (at'éeéd_i ... Ø_i), (ashkii_j ... yi_j)

Thus, by considering morphological properties to be independent of syntactic properties, which leads to the view that the morphological properties of an affix do not necessarily render it inaccessible to all syntactic processes, we can explain the Navajo facts which under other

assumptions seemed paradoxical.

It should be noted that although I am assuming that the Verb is the head of S in Navajo, that is, that there is no INFL constituent, I believe that the above analysis would hold, *mutis mutandi*, if it should turn out that the Navajo Sentence is a projection of INFL. If these agreement clitics are actually in INFL, they are still a sub-part of an X-zero category, namely INFL, and this important descriptive fact must be explained.

In the following, and final, chapter, I turn to an examination of certain syntactic facts which have led to the conclusion that Navajo overt nominals are in adjoined positions. I will claim that these facts do not obviate the evidence presented in Chapter 2 that overt nominals do not behave syntactically like adjuncts. Further, there are some curious regularities in the relevant facts which are left unexplained under the nominals-as adjuncts hypothesis. What I will show is that the constructions in question are interpreted as 'Across-the-board' constructions.

Chapter 4

An Across the Board Account of Navajo Relative Clauses

4.1 Introduction

The Navajo language comes by its status as a "nonconfigurational" language somewhat indirectly. It has never been argued that Navajo lacks a VP constituent and the word order of Navajo is quite rigid. Nor is the rich system of verbal affixes discussed in the previous chapter the primary fact which has motivated a nonconfigurational account of Navajo. Rather, Navajo has been classified as a nonconfigurational language by Hale (1981, 1983, 1986), Jelenek (1984), Willie (1985), and Sandoval and Jelenek (1985) because of some curious facts about the interpretation of pronominal elements.

In particular, Hale has emphasized certain constructions in Navajo in which violations of Binding Principles would result if the sentence is assigned a representation with empty pronominals. Since the Projection Parameter proposed by Hale (1983) (as well as the W^*/X bar typology of Hale (1981) and the Projection Parameter as revised by Jelenek (1984)) allows a sentence to be assigned a (PS) representation which contains no empty pronominals, the binding violations which might be found in

the Navajo cases disappear if Navajo is classified as a nonconfigurational language. We may simply state the relevant binding condition over PS, at which no null pronominals appear.

The specific example cited by Hale is the following:

- (4.1) Adáááá' ashkii at'ééd yiyiitsá(n)-éé yidoots'qs
 yesterday boy girl saw REL will kiss
 'He/she will kiss the girl that the boy saw yesterday (Hale(1981: 58))

Later in this chapter I will discuss Navajo relative clauses in more detail, at this point, I will just explain the particular problem that Hale was illustrating with this sentence. For this sentence which contains a typical Navajo 'internally-headed' relative clause (see Section (4.2.1) for details) there exists a grammatical reading in which the subject is an empty pronominal which is construed as coreferent with an NP which is internal to the relative clause. This reading and its structure are given in (4.2).

- (4.2) He_i will kiss the girl that the boy_i saw yesterday

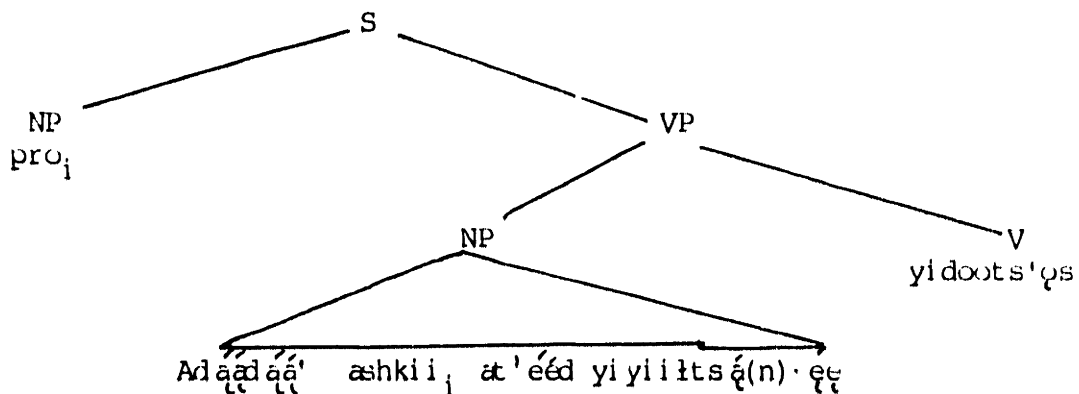

This reading is a violation of Condition C of the binding theory which states that R-expressions must be free. The empty pronominal c-commands and is coreferent with the R-expression boy, thus boy is

bound in violation of Principle C. Although the sentence structure is drawn with a VP node, it should be pointed out that the subject would c-command the R expression in this case even if the sentential structure were flat:

(4.3) Hc_i will kiss the girl that the boy_i saw yesterday

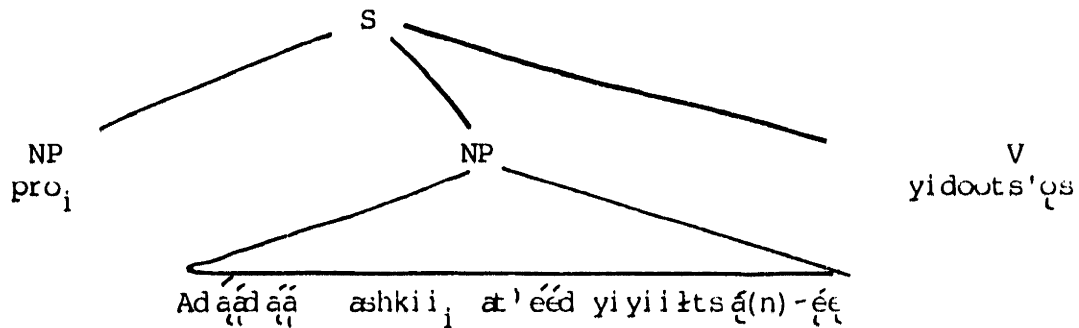

It is cases like this one which led Hale to classify Navajo as one of the languages which has a dual representation, and thus whose PS contained no empty pronominals. Under Hale's theory we may represent the sentence in question as in (4.4). If we assume that Binding Condition C is defined over PS, then no violation results in this sentence. Because the PS representation does not contain any empty elements, no pro is present to bind the R expression, therefore the R-expression ashkii is free at PS.

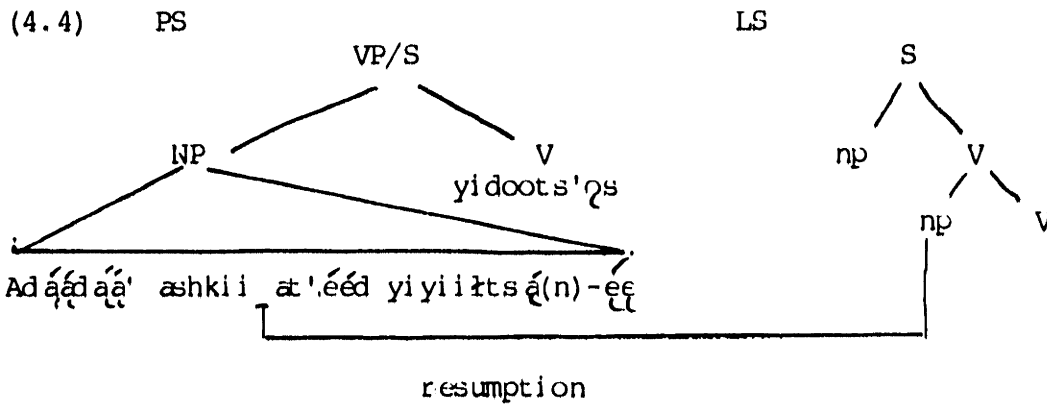

Under Hale's theory, the solution to this problem in Navajo was a consequence of the model that he devised to deal with quite different problems for Warlpiri and other languages. Thus, it seemed to provide support for the dual representation hypothesis.

In the remainder of this chapter, I will consider the Navajo case in more detail. The problem which Hale cited is only one of an interesting set of problems involving relative clauses in Navajo. I will argue that if we examine the possible interpretations of these relative clauses, what emerges is a curious parallelism constraint: these sentences are interpreted as though the matrix and relative clause were parallel, in some sense to be made clearer as we proceed. This observed parallelism will lead me to give an Across the Board account of the data. Such an account turns out to be quite straightforward, capturing all the facts, including cases which previous analyses have failed to explain.

Before turning to the relative clause constructions themselves, I will outline the relevant facts about Navajo sentence structure. I will then present the paradigm to be accounted for and will explain why an ATB account seems to be motivated.

Once I have shown how the ATB account captures the observed parallelism constraint, I will turn to a discussion of the status of ATB representations in a restrictive theory of phrase markers. This will involve a review of the three suggestions which have been made within GB theory as to the origins of ATB representation (i.e., Williams(1978), Goodall(1984) and Haik(1986)) as well as an exploration

of the consequences of considering the ATB effects in Navajo as arising from a constraint on extraction or as a constraint on coindexing.

Along the way, I will present some interesting data from two other languages, Bella Coola and Hopi which show a parallelism effect similar in many ways to the one in Navajo. I will also evaluate and reject several recently proposed alternative accounts of the constraints on coreference in Navajo.

4.2 Navajo Sentence Structure

4.2.1 Simple Sentences

As discussed in Chapter 3, the Navajo verb is highly inflected, and includes prefixes marking person and number of both subject and object. Navajo NPs are not morphologically marked for case (or even number, in most instances), as shown in (4.5), where word order alone indicates the grammatical function of the overt NP.

- (4.5) a) At'éeéd ashkii yiyiitsá.
girl boy s/he-saw-him/her
'The girl saw the boy'
- b) Ashkii at'éeéd yiyiitsá
boy girl s/he-saw-him/her
'The boy saw the girl'

The word order shown above, SOV, is generally taken to be the unmarked basic word order. However, when both subject and object are third person, the verb may contain a prefix in the object slot which indicates that the word order is switched. Although the NPs in

sentences (4.6) a and b are the same, the interpretation of grammatical relations is "switched". In (4.6a), the object prefix is yi, and the word order is SOV, in (4.6b), the object prefix is bi, the the word order is OSV. "switched" due to the object prefix.

(4.6) a) ashkii a't'ééd yi yíiitsá.
 boy girl yi-saw
 'The boy saw the girl'

b) ashkii a't'ééd b-iíitsá.
 girl boy bi saw
 'The girl saw the boy'

Both subject and object may be null in Navajo, as in (4.7):

(4.7) a) yi-yíiitsá.
 yi saw
 'S/he saw him/her'

b) b-iíitsá
 bi-saw
 'S/he saw him/her' (talking about him/her)

c) shíí nígháád you shook me
 (shi+yi+ni+gháád)
 me+perf+you+shook

d) níígháád I shook you¹
 (ni+yi+sh+gháád)
 you+perf+I+shook

e) yígháád I shook him/her (YM p.170)
 (Ø+yi+sh+gháád)
 him/her+perf+I+shook

Although either Subject or Object (or both) may be null, as shown in (4.8), the interpretation is restricted when both arguments are third person.

 1. This form also means "he/she shook you". sh- drops out by a phonological rule, making the form ambiguous.

(4.8) a. At'éeéd yíiḥtsá.
 girl yi-saw
 'Sh/he saw the girl'
 NOT='The girl saw him/her'

b. At'éeéd b-iḥtsá.
 girl bi-saw
 'The girl saw him/her'
 NOT= 'Sh/he saw the girl'

In simple cases like a and b above, we may say simply that the sentence may not be interpreted as though there were a "gap" between the NP and the verb. Platero (1978) formalized this observation as the NP-PRO Constraint:²

NP-PRO CONSTRAINT: If PRO immediately follows an overt noun phrase NP', it must be coreferential with NP'.
 (Platero 1982:288)

The NP-PRO constraint may be thought of as an obligatory control rule.³ This constraint rules out an empty pronominal after an overt NP because the empty element, being [+pronominal], must be free in its governing category, by Binding Principle B. The NP-PRO constraint would automatically coindex an empty object pronominal with an overt NP, in violation of Condition B. Note that if the verbal morphology identifies

2. Platero used the label PRO as a generic empty element label. The empty category in these cases seems to be small pro, since it is a sister to the verb. As Walli (1983) pointed out, it is difficult to tell whether the subject position is governed by the verb or not, so under the assumption that there is no overt INFL in Navajo, it is difficult to tell whether the empty subject is PRO or pro. It is also not clear whether anything of consequence depends on the distinction.

3. Platero's NP-PRO constraint is essentially identical to the Generalized Control Rule (GCR) proposed for Chinese by Huang (1983). In Section (4.5), I will discuss the possibility of applying Huang's theory of empty objects to the Navajo data, showing that it is insufficient for the more complex cases.

an object as reflexive or reciprocal, then the object may, in fact, must be empty. (4.9), where the verb is not reflexive, is ungrammatical, while (4.10), where the verb is reflexive, is grammatical.⁴

(4.9) Ashkii yiyiitsé.
 *boy_i he-saw-him_i
 *'The boy_i saw him_i.'⁵

(4.10) Ashkii ádiiltsé.
 boy he-saw-himself
 'The boy saw himself' (Platero 1978:108)

However, Platero showed that the NP-PRO Constraint was inadequate for various types of more complex examples. I will be focussing attention on one of Platero's counterexamples to the NP-PRO constraint, namely, sentences in which one of the arguments is a relative clause. In the following subsection, I will describe relative clauses in Navajo, and then I will show how they pose a problem for all existing theories of Navajo grammatical relation assignment.⁶

4. It is not obvious that there really is an empty argument in the reflexive case; we might say that the verbal morphology removes the object that a role in some way. However, see Saxon (1986) for some quite convincing arguments that an equivalent construction in Dogrib, another Athabaskan language, does contain an empty pronominal which is also anaphoric.

5. This sentence is grammatical on the disjoint reading where ashkii is the object, i.e. 'He_i saw the boy_j.'

6. In what follows, unless the bi- verb forms are explicitly mentioned, I will generally be restricting my discussion to the yi- verb forms, where SOV order is basic.

4.2.2 Relative Clauses

In the preferred form for a relative clause in Navajo, the NP which is construed as the 'head' of the relative clause is located within the relative clause itself at surface structure. The relative clause itself is "nominalized" by means of a definite determiner -yée (-éé, -áá). These have been called "internally headed" relative clauses.

- (4.11) [Tl'éeéd áá' ashkii áh áá'- áá] yádoox'tih.
 last night boy snore-REL will:speak
 'The boy who was snoring last night will speak.'
 (Platero 1974:204)

For some speakers, (4.12), in which the relative clause does have an external head at surface structure, would also be acceptable. (cf. Platero 1974, 1978)

- (4.12) [Tl'éeéd áá' áh áá'- áá] ashkii yádoox'tih.
 last night snore-REL boy will:speak
 'The boy who was snoring last night will speak.'
 (Platero 1974)

I will tentatively assume, following Barss, Hale, Perkins and Speas (in press) that the logical form of an internally headed relative clause is derived by movement⁷ extracting the relative NP and adjoining it to the nominalized clause⁸ and leaving a trace in the

7. This assumption is tentative, because I believe that there is evidence that the null object in a sentence like 4.12 is not an A-bar bound trace.

8. In the absence of a complete theory of Navajo phrase structure, I will leave open the precise landing site of the head NP, and assume tentatively that it is Chomsky-adjoined to the nominalized S, resulting in LF representations as in (4.13). If the NP moves directly into head

source argument position. The Logical Form representation of (4.12), then, would be (4.13).⁹

(4.13) [Tl'éeédǫǫ' t_i a'hǫǫ'-ǫǫ] ashkii_i yádooitih.
 last night snore-REL boy will:speak
 'The boy who was snoring last night will speak.'

For many speakers, movement in LF is not limited to particular arguments, so that internally-headed relative clauses are ambiguous. The string in (4.14) may mean either 'the man who roped the horse' or 'the horse that the man roped', depending on which NP is interpreted as the head (i.e., depending on which NP is moved at LF.)

(4.14) hastiin ǫǫǫ' yizloh-ǫǫ
 man horse he-roped-it-REL

LF1: [t_i ǫǫǫ' yizloh-ǫǫ] hastiin 'the man who roped the horse'
 OR
 LF2: [hastiin t_i yizloh-ǫǫ] ǫǫǫ' 'the horse that the man roped'

Recall that the clause-internal surface position of the NPs can be confirmed by placing an adverb in the subordinate clause, as in example (4.1).

 position, a subjacency violation should result. However, if we adopt the structure of S' proposed by Chomsky (1986a) and assume that the relativizer is base-generated as the head of CP, then the specifier of CP is available as a landing site. Alternatively, the relativizer might be the head of a complex NP. There seems to be independent evidence that Navajo relative clauses are actually complex NPs (Hale, p.c.)

9. See Barss, Hale, Perkins and Speas (forthcoming) for discussion of the landing site of the relative NP. See Williamson (1984), Cole (1985) and Broadwell (1985) for discussion of LF movement for this construction in other languages.

4.3 Parallelism in Relative Clause Constructions

A set of unexpected problems emerges when one of these ambiguous internally-headed relative clauses is embedded under a transitive verb. In what follows, I will discuss the paradigm of judgements drawn from Platero (1974), (1978) and (1982).¹⁰ Platero examined sentences which contained two overt NPs, a transitive relativized verb and a transitive matrix verb. The relativized verb itself is nominal, and may act as an argument. Thus, in the paradigm shown in (4.15), there are three nominals and four potential argument positions. Consequently, one of the four arguments is always a pronominal. If we represent this pronominal argument with an empty element pro, this pro may potentially occur in any one of the four positions shown in (4.15). Platero tested all of the logical possibilities, and (4.15) is the paradigm which emerges.¹¹

(4.15) Transitive relative clause + transitive matrix verb:
(Platero 1978:128-152)

hastiin	híí'	yizloh-éé	yí'diítid
man	horse	he-roped-it-REL	he-branded-him

10. Platero was working within a framework in which empty pronominal elements were derived from overt NPs by means of a pronominalization transformation, so he should not be considered responsible for my exposition of the regularities exhibited by the data which he examined.

11. For convenience, I have omitted interpretations in which subject and object are interpreted as linked. These would all be ungrammatical, since the verb I am using is not marked as reflexive.

- i) pro [_{NP}[_S man horse roped]REL] branded
- a) 'He_i branded the horse that the man_i roped'
 - b) 'He/she_j branded the horse that the man_i roped'
 - c) 'He/she_j branded the man that roped the horse_i'
 - d) *'It_i branded the man that roped the horse_i'
- ii) man [[pro horse roped]REL] branded
- e) 'The man_i branded the horse he_i roped'
 - f) *'The man_i branded the horse he/she_j roped'
 - g) *'The man_i branded the one_j who roped the horse'
- iii) [[man horse roped] REL] pro branded
- h) 'The man who roped the horse_i branded it_i'
 - i) *'The man who roped the horse_i branded him/her_j'
 - j) *'The horse that the man_i roped branded him_j'
 - k) *'The horse that the man_i roped branded him_i'
- iv) * man [[horse pro roped]REL] branded
- l) *'The man_i branded the horse that roped him_i'
 - m) *'The man_i branded the horse that roped him/her_j'
 - n) *'The man_i branded the one_j that the horse roped'

As this paradigm shows, the string is potentially 14 ways ambiguous, but only five of the possible readings are grammatical. These five are isolated in (4.16).

(4.16) GOOD READINGS:

- a) 'He_i branded the horse that the man_i roped'
- b) 'He/she_j branded the horse that the man_i roped'
- c) 'He/she_j branded the man that roped the horse_i'
- e) 'The man_i branded the horse he_i roped'
- h) 'The man who roped the horse_i branded it_i'

Although the full paradigm is quite intractable, we find an

interesting pattern in the cases which pose theoretical problems. There are two problem structures, which I will discuss in detail below. In both cases, there is an empty pronominal appearing in a position where it ought to be ruled out, and in both cases the interpretation of this unexpected empty pronominal is restricted. In particular, the arguments of the the matrix and relative clause are interpreted as though they were parallel and coindexed across the board.

The first case that presents problems is (4.15.i), where the relative clause is parsed as the object, and the subject is an empty pronominal. The structure for this is shown in (4.17).

(4.17) STRUCTURE (4.15.i)

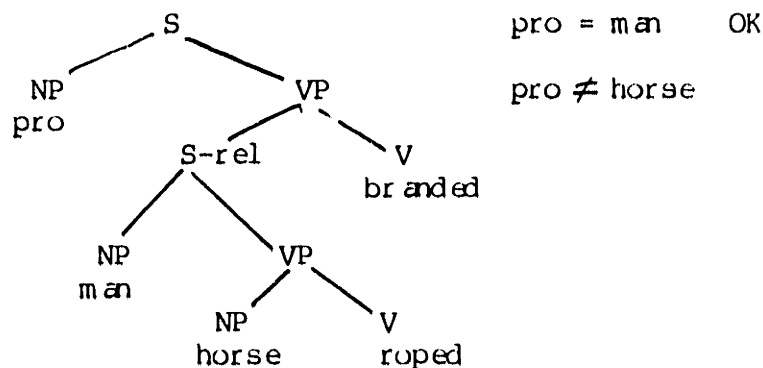

This case presents two problems:

1. What accounts for the grammaticality of 'He_i branded the horse that the man_i roped' (reading (4.15. a)), where the empty pronominal precedes, is coindexed with and c-commands (therefore binds) the referring expression man, in violation of standard coreference principles?

2. Why is this exceptional coreference restricted to the embedded subject? That is, how can we rule out 'It_i branded the man who roped the horse_i' ((4.15.d))?

String (4.15.iii), in which the relative clause is interpreted as the subject of the whole sentence, presents a similar pair of problems.

(4.18) STRUCTURE (4.15).iii)

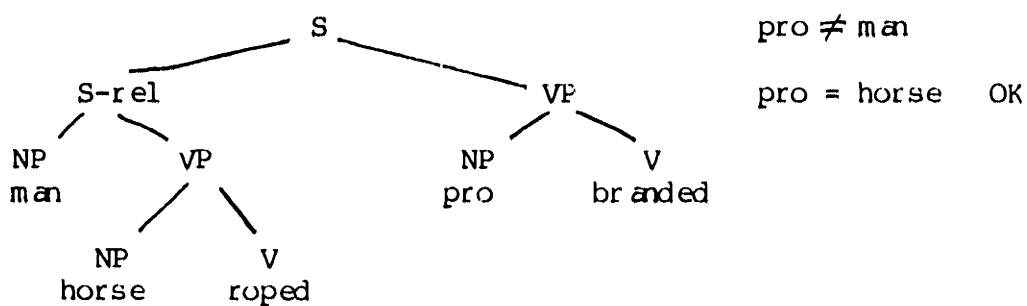

The problems with this structure are:

1. Why is a null object allowed here, in violation of the NP-PRO constraint? That is, what accounts for the grammaticality of (4.15.h), 'The man who roped the horse_i branded it_i'?
2. Why is this null object restricted, being permitted only if it is coreferent with the object in the relative clause? That is, what accounts for the ill-formedness of the reading which means 'The horse that the man roped branded him'?

We may summarize the problems raised by this paradigm as follows. A matrix null object is exceptionally permitted only if it is coreferent with the embedded object, and a matrix null subject may exceptionally bind only the embedded subject.

Platero's proposed solution to this problem was a parsing algorithm which assigns Grammatical Functions to NPs based on linear order. The effect of this parsing strategy is to insure that if a given NP is assigned a grammatical function in one of the clauses, it is assigned the same grammatical function in the other.

(4.19) INTERPRETATION OF GRAMMATICAL RELATIONS

In an overt string of the form

$(NP_b) NP_a X V$

(i) NP_a is alpha obj if the object marker is alpha yi

AND

(ii) NP_b is alpha obj if the object marker is -alpha yi

(Platero 1982:296)

The IGR is sensitive only to phonetically-realized NPs, and might be thought of as a rule mapping phonetic form onto argument structure.

The parsing strategy, unfortunately, is not without problems. As Walli (1983) points out, the most serious problem with the parsing strategy is that the constraints on interpretation which it is designed to predict hold even when there are no overt NPs in the sentence. That is, (4.20) has only the interpretation shown.

(4.20) Yi zloh-~~ee~~ yi'diifid.
 he-roped-him-REL he-branded-him

He_i branded the one that he_i, ?_j roped.

Secondly, it must be stipulated that the 'X' variable in the above rule cannot be an overt NP. If the variable could be an overt NP, then sentences like (4.21) ought to have the reading indicated in a, but

this reading is impossible.

(4.21) ashkii adzáán á'éeéd yizts'qs ní-(n) éé hadoolg aazh
 boy woman girl kissed-rel said-rel screamed

- a) *The girl who said that the boy kissed the woman screamed.
- b) The boy who said that the woman kissed the girl screamed.
- c) The woman the boy said kissed the girl screamed.
- d) The girl who the boy said the woman kissed screamed.

(Plátero 1978:45)

Unless the parsing rule specifies that the variable cannot be an overt NP, we would expect the parsing rule to be allowed to apply as in (4.22). In this example, the parsing rule applies cyclically, with the lowest clause parsed first, and the word á'éeéd has been designated as the variable by the parsing algorithm. Since á'éeéd is designated as the variable on this cycle, the string-initial word ashkii is parsed as NP2, and therefore is assigned the subject grammatical function, and the second word in the string, adzáán is parsed as NP1, and is therefore assigned the object grammatical function. Thus, the lower clause would mean 'the boy kissed the woman'.

(4.22)	ashkii	adzáán	á'éeéd	yizts'qs	ní-(n) éé	hadoolg aazh	
	boy	woman	girl	kissed	said-rel	screamed	
	NP2	NP1	X	V			LOWEST CLAUSE
			NP		V		REL CLAUSE
			NP			V	MAIN CLAUSE

- a) *The girl who said that the boy kissed the woman screamed.

Recall that the parsing strategy does allow the subject of a matrix sentence to be within a complement clause, so unless it is stipulated that the variable in the parsing rule cannot be an NP, the derivation

above would be perfectly acceptable.

Thirdly, the IGR must operate from right to left. While such a strategy might certainly be possible on the assumption that we hear and store whole clauses before applying any parsing rules, it is at variance with many available models of parsing, which generally parse as the string is received.

A more serious objection to the right to left parsing procedure is that it cannot simply assign any structure which is compatible with the general principles of grammar (eg. the theta criterion, projection principle, etc.). Instead, it must operate right to left stopping immediately as soon as it reaches any overt NP, and assign that NP some particular grammatical function. That this is problematic is illustrated by the following contrast.

(4.23) a) Ashkii at'éeéd yí'déésool-éé deezgo'
boy girl whistle-rel fell

'The boy who is whistling at the girl fell'
'The girl who the boy is whistling at fell'

b) At'éeéd yí'déésool-éé ashkii deezgo'
girl whistle-rel boy fell (p 57)

'The boy who is whistling at the girl fell'

NOT 'The girl who the boy is whistling at fell'

(4.24) hastiin at'éeéd yiyiiktsâ(n)éé ashkii yí'd. 'soot
man girl saw-rel boy whistle

a) *The man is whistling at the boy who saw the girl.

b) The man who saw the girl is whistling at the boy.

c) The girl that the man saw is whistling at the boy.

(Pl.tero 1978:27)

As discussed earlier, internally-headed relative clauses are ambiguous, while externally-headed relative clauses are unambiguous. In (4.23)b, the subject of the intransitive verb is an externally-headed relative clause. That is, the entire string at'ééd yí'déésooléé ashkii is parsed as a constituent. However, in (4.24), the structurally identical string at'ééd yiyiitsá-(n)éé ashkii cannot be parsed as a unit. Instead, the IGR must operate so as to stop as soon as it reaches the NP ashkii and assign it the object grammatical function. This discrepancy between the parsing of a transitive and an intransitive sentence calls the parsing strategy into question.

A fourth problem with the parsing strategy is that it must somehow be prevented from applying to sentences with certain types of complement clauses. In particular, as Platero points out, the IGR must be allowed to fail to apply in cases like (4.25), which has an interpretation in which the arguments of the matrix verb are disjoint from the arguments of the embedded verb.

(4.25) a) Ashkii at'ééd yídeelchid-go yizts'qs.
 boy girl touched-COMP kissed

'When the boy_i touched the girl_j, he/she_k kissed him/her₁.'

'When the boy_i touched the girl_j, he_i kissed her_j.'

'When the boy_i touched the girl_j, he_i kissed him/her_k.'

NOT 'When the boy_i touched the girl_j, she_j kissed him_i.'

In this case, the IGR may simply fail to apply, whereas the parsing rule is obligatory in the relative clause case.

Thus, we seem to have a paradox: The representation with empty pronominals, which would be required by the Projection Principle, violates both Condition C of the Binding theory and the NP-PRO constraint, while the parsing strategy which obviates the need for empty pronominals makes the wrong predictions for structures other than relative clauses, and cannot capture the curious parallelism constraint exhibited by the the coreference facts. The above objections should not be taken as arguments that Navajo has no parsing mechanisms. Clearly, all languages have parsing procedures of some sort. Woolford(1986) proposes that we view Platero's IGR as an autosegmental mapping rule, mapping overt NPs onto grammatical functions. Her insight is that an autosegmental mapping procedure may be the right formalism for capturing the relationship between S-Structure and PF. However, it is not at all clear that the evidence establishes that Navajo varies parametrically from English in the degree to which grammatical functions are unspecified at S-Structure. As I will argue in the following sections, the facts of Navajo may be captured without supposing that Navajo has a language-particular parsing strategy to compensate for some underspecified syntactic structure. I will comment on Woolford's interesting proposal in section 4.6.

To account for the parallelism effect which were observed in Navajo sentences with relative clauses, I will propose that we take the observed parallelism literally, and try to give an account in which the matrix and relative clauses are represented in parallel. We get the right empirical results by assuming that the matrix and relative clause are represented in the Across-the-Board(ATB) representations used by

Williams (1978) and formalized by Goodall (1983) for coordinate constructions, and that extraction from these representations is restricted such that if extraction takes place out of one clause, the parallel constituent must be extracted out of the other clause.

In the section which follows, I will show how the empirical results are achieved, while remaining somewhat vague about the formal properties of the ATB representations being used. The formal properties of these representations are not well understood, and the theoretical status of across-the-board constraints on extraction is controversial. Therefore, I will first give the ATB account of the Navajo facts, and then in Section (4.7), I will discuss the theoretical status and formal properties of ATB representations at some length.

4.4 An Across-the-Board Treatment of Navajo Relative

Clauses

In Section (4.3), I observed that the parallelism in interpretation of grammatical relations in Navajo sentences with relative clauses suggests that we treat them as Across-the-Board constructions. Recall that the Logical Form of these internally headed relative clauses involves construing one of the argument NPs as the head NP at LF. In this section, I will go through the Navajo cases to show how the ATB account works, being as noncommittal as possible as to the precise nature of ATB effects.

For expository purposes, I will instantiate the ATB format by pulling the subordinate clause out of the sentence and placing it parallel to the matrix clause. In my diagrams, I will arbitrarily write the matrix clause on top. The general descriptive constraint on ATB constructions may be stated as follows:

CONSTRAINT ON ATB INTERPRETATION: In a parallel structure P, made up of component sentences S_1 and S_2 , the subject of S_1 and the subject of S_2 must be coreferential, and the object of S_1 and the object of S_2 must be coreferential.

In what follows, I will represent all null arguments (i.e. all arguments except man and horse) as 'pro', reserving judgement on the question of whether some are actually variables rather than pronominals.

I will assume that the NP-PRO constraint is a completely general control rule, which always indexes an empty pronominal with a c-commanding overt NP. This will rule out both of the cases with pro in object position at S-structure (repeated here as (4.26) and (4.27)).

(4.26) * man [_Shorse pro roped]REL] branded (=4.15iv)

(4.27) * [_Sman horse roped] REL] pro branded (=4.15iii)

Now I can limit my examination to two parsings for the string: one in which both overt nominals are inside the relative clause, and one in which man is outside the relative clause and horse is inside. If we express both of these possibilities in ATB format, that is, by writing the matrix clause on top of the relative clause, we get two possible ATB

representations for the string in question. Let's consider each of these in turn.

The case in which both overt NPs are within the relative clause can be represented as (4.28).

(4.28) pro pro braided
 man horse roped-rel

The Constraint on ATB Interpretation requires that the subjects and objects be coindexed as shown in (4.29).

(4.29) pro_j pro_j braided
 man_i horse_j roped-rel

At LF, either NP may be construed as the head of the relative clause. Because the Constraint on ATB Interpretation mandates the coindexing shown, the construal of a given NP as the head of the relative clause will determine the position of that clause as a whole. This is because construing a given NP as the head of the relative clause effectively identifies that NP with the clause as a whole, setting up a predication relation. Since that NP is already identified with an NP in the matrix clause, the predication relation will automatically also hold of that parallel NP and the relative clause as well. So if the subject of the relative clause is construed as the head, then the relative clause is identified with the subject of the matrix, and if the object of the relative clause is construed as the head, then the relative clause is identified with the object of the matrix. This yields the two readings given in (4.30) and (4.31).

(4.30) SUBJECT AS HEAD = RELATIVE CLAUSE AS SUBJECT

pro_i pro_j branded
t_i horse_j roped-rel man_i

'The man who roped the horse_j branded it_j' (=4.15h)

(4.31) OBJECT AS HEAD = RELATIVE CLAUSE AS OBJECT

pro_i pro_j branded
man_i t_j roped-rel horse_j

'He_i branded the horse that the man_i roped' (=4.15a)

(4.30) is the supposed violation of Platero's NP-PRO constraint, that is, the interpretation which seems to allow a gap in object position, but with the ATB format, there is no violation; we construe the relative clause as the matrix subject because the subject of the relative clause is construed as the head, which is already identified with the parallel constituent in the matrix sentence. At S-Structure, where the NP-PRO constraint applies, there is no c-commanding lexical NP to coindex with the pro object.

(4.31) is the case which seemed to violate standard coreference principles, that is, where Condition C of the Binding Theory seemed to be violated. But in the ATB format, there is no c-command relation between the referring expression man and the pronominal, so no violation results.

Now we turn to the parsing in which one NP is in the matrix clause and the other is in the relative clause. This string goes into ATB

format as (4.32).

(4.32) man pro branded
 pro horse roped-rel

However, this representation ought to be ruled out, because applying the NP-PRO constraint and the Constraint on ATB Representations will result in an impossible coindexing, whereby the matrix object *pro* will end up coindexed with both man and horse. Or, more simply, we may say that this representation is ruled out because one of the component sentences is ill formed, violating the NP-PRO constraint.

The across the board format thus gives us all and only the readings which were problematic in for earlier theories. The other three well-formed readings are exactly the ones that we get if the strings are given normal, non-ATB representations.

From (4.33), we get readings (4.34) or (4.35), depending on which NP is construed as the head of the relative clause.

(4.33) pro [man horse roped]-rel branded

(4.34) He_j branded the horse that the man_i roped. (=4.15b)

(4.35) He_j branded the man who roped the horse_k. (=4.15c)

The NP-PRO constraint applies to the other parsing, coindexing the empty embedded subject pronominal with the matrix NP subject, as shown in (4.36), so the only possible grammatical reading of the string is (4.37).

(4.36) man_i [pro_i horse roped]-rel branded

(4.37) The man_i branded the horse that he_i roped. (=4.15e).

All other readings in the paradigm are ruled out by independent principles. I repeat the paradigm here to make this clear, noting which principles rule out each ungrammatical reading.

(4.38)

hastiin lii' yizloh-ee yi'diilid
man horse he-roped-it-REL he-branded-him

i) pro [_{NP}[_S man horse roped]REL] branded

- a) 'He_i branded the horse that the man_i roped'
- b) 'He/she_j branded the horse that the man_i roped'
- c) 'He/she_j branded the man that roped the horse_i'
- d) *'It_i branded the man that roped the horse_i'
Ruled out by Binding Condition C, and not
generable in ATB format.

ii) man [[pro horse roped]REL] branded

- e) 'The man_i branded the horse he_i roped'
- f) *'The man_i branded the horse he/she_j roped'
Ruled out by NP-PRO constraint
- g) *'The man_i branded the one_j who roped the horse'
Ruled out by NP-PRO constraint

iii) [[man horse roped] REL] pro branded

- h) 'The man who roped the horse_i branded it_i'
- i) *'The man who roped the horse_i branded him/her_j'
Ruled out by NP-PRO constraint; not
generable in ATB format
- j) *'The horse that the man_i roped branded him_j.
Ruled out by NP-PRO constraint; not
generable in ATB format

k) *'The horse that the man_i roped branded him_i.
 Ruled out by NP-PRO constraint; not
 generable in ATB format

iv) * man [[horse pro roped]REL] branded
 Ruled out by NP-PRO constraint
 in all interpretations

l) *'The man_i branded the horse that roped him_i'

m) *'The man_i branded the horse that roped him/her_j'

n) *'The man_i branded the one_j that the horse roped'

This accounts neatly for all of the facts in the paradigm, and does not generate any ungrammatical readings. This account also can capture the fact that the restrictions on interpretation are even stricter for sentences like (4.39), in which there are no overt NPs.

(4.39) Yizloh-ee yi'diilid.
 s/he-roped-it sh/e-branded it
 'S/he branded the one that s/he_i,?j roped'

There is only one possible parsing for this sentence which obeys all independent principles. That is the parsing in which the nominal relative clause yizloh-ee is taken as the matrix object. Furthermore, unlike the case in which overt NPs appear, where sentences containing proper names can be constructed to prove the existence of alternative interpretations, the ATB interpretation of (4.39) in which the relative clause is identified with the subject, (4.40), is indistinguishable from the interpretation above.

(4.40) The one who roped it_i branded it_i.

I have suggested an account of Navajo relative clauses using ATB representations such as those proposed for English conjunctions. Of course, the Navajo constructions that I examined are not conjuncts,

rather, they are embedded constructions which I said vaguely were "pulled out" of the matrix clause. The fact that such an analysis seems to yield a straightforward account of the facts raises a set of related questions about the properties of ATB representations:

1. Under what circumstances do ATB representations arise?
2. How may these representations be formalized within a restrictive theory of phrase markers?
3. Precisely which principles of Grammar operate "across the board"?
4. Why do these and only these principles operate "across the board"?

These questions will be addressed in Section 4.7, where I will also review the only existing attempt to formalize ATB representations for coordinate constructions, i.e. Goodall(1984), and will present several other recent ATB accounts of non-coordinate constructions.

4.5 On the Inadequacy of a Simple Pro-drop Account of Navajo

In this section, I will attempt to give an account of the Navajo facts without resorting to the use of ATB representations. As with Platero's original account, this account will work for simple sentences, but for relative clauses, I will show that the rule of coreference for empty pronominals which would be needed is totally ad

hoc, and seems to miss the important generalizations observed in the data.

My account will be based on the work of Huang (1984), who outlines a theory of the parameters which distinguish languages which allow extensive argument-drop from those which require overt expression of arguments. Human languages vary in the extent to which arguments required by a verb may be left unexpressed in the surface representation. At one extreme are languages like English and French, in which all governed argument positions must be lexically filled. At the other extreme are languages like Chinese, Japanese and Navajo, in which empty NPs are allowed much more freely. Languages like Spanish and Italian¹² which may omit only the subject seem to fall somewhere in between. An interesting observational fact is that we find languages which appear to drop subject only and languages that appear to allow both subject and object to be dropped, but we do not find languages which allow object drop only.

Huang's theory, which is an attempt to characterize formally the notions "discourse oriented" and "sentence oriented", is designed to apply to languages which have either no subject agreement or very rich subject agreement. He supposes that languages with rich object agreement should fall outside his theory, and he gives some data from Pashto as an example.

12. Rizzi (1985) argues that Italian, but not English, allows null objects in certain constructions.

In this section, I will examine Huang's proposals to see if they provide us with a satisfactory alternative account of the Navajo facts. Although Navajo has subject and object agreement markers, it shows some surprising similarities with Chinese in the restrictions on object drop. I will examine the consequences of extending Huang's analysis of Chinese/Portuguese type languages to Navajo.

4.5.1 Huang's Proposal

Huang notices that in Chinese and Portuguese, which appear to allow empty objects, we find that the distribution of zero objects is more restricted than that of zero subjects. Chinese, for example, allows quite free argument drop in simple sentences, as shown in (4.41) (Huang's (19)), yet subject/object asymmetries show up in examples like (4.42) (Huang's (22)).¹³

- (4.41) a) e lai-le
 come-LE
 '(He) came'
- b) Lisi hen xihuan e
 Lisi very like e
 'Lisi Likes (him) very much.'

13. Huang's data has been disputed in various places, including Batistella(1985), and his analysis of the empty object in Chinese as a variable has been questioned by Xu Liejiong(1986). Xu concludes that certain empty categories in Chinese simply do not fit into any known typology of empty categories. I think that the issues raised by Huang in his attempt to give a syntactic characterization of the notion of Discourse Topic are interesting, and further, the Generalized Control Rule which Huang proposes is almost identical to the NP-PRO constraint suggested for Navajo by Platero(1978). Therefore, I am using Huang's theory as a background for an analysis of Navajo which does not use ATB representations.

- c) Zhangsan shuo [e bu renshi Lisi]
 Zhangsan say not know Lisi
 'Zhangsan_i said that he_{i,j} did not know Lisi'
- d) Zhangsan shuo [Lisi bu renshi e]
 Zhangsan say Lisi not know
 'Zhangsan_i said that Lisi did not know [him_j, *i]

(4.42) a) Zhangsan_i xiwang [e_i keyi kanjian Lisi]
 Zhangsan hope can see Lisi
 'Zhangsan_i hopes that [he_i] can see Lisi.'

b) *Zhangsan_i xiwang [Lisi keyi kanjian e_i]
 Zhangsan hope Lisi can see
 'Zhangsan_i hopes that Lisi can see [him_i]

Huang suggests that general principles of binding theory and control theory conspire to prohibit empty pronominals in object position. In particular, his rule of control, the Generalized Control Rule (GCR), requires a coindexing which will always result in a violation of Condition B of the Binding Theory, which he formulates as the Disjoint Reference Rule (DJR).

(4.43) GCR: Coindex an empty pronominal with the closest nominal element.

DJR: A pronoun must be free in its governing category.

In English, the "closest nominal element" would be the agreement element in INFL, which is always coindexed with the subject. In Chinese there is no overt INFL, so the subject itself would always be the "closest nominal element". Since the GCR is obligatory, it has the effect of creating a violation of Principle B of the Binding Theory (the Disjoint Reference Rule) whenever it applies to pro in object position. In English, this violation occurs because the object pro

would be obligatorily coindexed with INFL, which is in turn coindexed with the subject NP. In Chinese, the violation occurs because the object pro would automatically be coindexed with the subject NP. This violation can only be avoided in a language which has rich object agreement on the verb which can serve as the "closest nominal element". (Huang gives Pashto as an example of this last type.) Thus, null subjects in Chinese and in standard "Pro-drop" languages may be empty pronominals, while empty objects in the languages under investigation cannot be empty pronominals.

Huang argues that Chinese empty objects are actually variables, bound by empty operators in topic position. Under this analysis, the ungrammatical case above is a crossover violation. Huang first gives independent evidence that languages like Chinese and Portuguese may have empty operators in topic position binding variables in object position, so that (4.42) may be represented as (4.44).

(4.44) Zhangsan_i xiwang [OP_j [Lisi keyi kanjian t_j]
 Zhangsan hope (topic) Lisi can see
 'Zhangsan hopes that (as for him,) Lisi can see him.'

Since a topic is always new information, the null operator in embedded topic position will always refer to someone other than the already-introduced matrix subject. Therefore, coindexing the matrix subject with the object variable would be ungrammatical, having the flavor of a crossover violation.

4.5.2 Extending Huang's Analysis to Navajo

Huang did not intend his analysis to extend to languages which have object agreement, as Navajo does. However, it turns out that the simpler data in Navajo can be accounted for quite neatly under Huang's proposal. First, I will show a Huang-style account for the two types of simple transitive sentences in Navajo. I will then examine the relative clause cases discussed above and show that the auxiliary statements necessary to bring these data under a Huang-style account are so ad-hoc as to require reexamination of the entire account.

As mentioned above, Navajo appears to have object agreement, so there is no a priori reason to assume that Huang's analysis of Chinese should be extendable to Navajo. However, if we adopt the analysis of bi-verb forms proposed by Hale, Jeanne and Platero (1977) and Perkins (1978), in which such forms involve topicalization, then the paradigm to be explained for simple sentences looks very much like the Chinese data:

- | | |
|---|---|
| <p>(4.45) a) NP_i NP t_i bi-V
 b) e_i NP t_i bi-V
 c) e_i e t_i bi-V
 d) *NP_i e t_i bi-V</p> | <p>(4.46) a) NP NP yi-V
 b) e NP yi-V
 c) e e yi-V
 d) *NP e yi-V</p> |
|---|---|

The above paradigm parallels the Chinese facts in that (unless both Subject and Object are dropped) subjects and topics may be empty, but untropicalized objects may not. An account of these facts in Huang's framework would go as follows.

(45) a is a straightforward case of topicalization. No empty pronominal is involved. In (45) b, an empty operator is binding a variable in object position. Since there is no empty pronominal, no condition B violation results. In (45) c), We must assume that the subject *ec* is *pro*, while the object *ec* is a variable, since Navajo does not have the Chinese option of multiple topics.

(4.47) **aʃkii, a'éeé bi zhé'é. biiχtsá*
 boy girl his/her father was-seen by
 'As for the boy, the girl was seen by his father.'

(45) c, then, is the canonical case of a null operator binding an object variable, but the subject is *pro*, presumably assigned identificational features by the "strong enough" AGR.

(45)d is ruled out under a Huang-type analysis by the Generalized Control Rule (GCR) and the principle of Disjoint Reference (DJR) (i.e. principle B of the binding theory). The *pro*¹⁴ in subject position would, by the GCR, have to be coindexed with the topicalized NP, but then DJR is violated, so the representation is ruled out.

(4.48) **NP_i pro t_i bi-verb*

Notice that the contrast between (4.45) c and d indicates that the GCR seems to be applying only if there is a lexical NP close enough to act as the controller of *pro*. That is, another *pro* does not appear to count as a closest nominal element in Navajo. This problem did not

14. As discussed earlier, the evidence as to whether empty pronominals in Navajo are PRO or *pro* is inconclusive. In what follows, I simply use *pro* to indicate an empty pronominal, without claiming to have any answer to this question.

arise in Chinese because of the availability of more than one topic position. (i.e. the subject ec could also be a variable.)

Turning to the yi-verb cases, case a is a straightforward transitive sentence with both arguments lexically filled. Case (b), where the subject is empty while the object is lexically filled. is a standard pro-drop configuration. Presumably AGR in Navajo is strong enough to identify subject pro. Case (c), in which both subject and object are dropped with a yi-verb leads us to believe that the object agreement marker in Navajo is strong enough to identify an empty object. Again, in case (c), we find that the GCR does not require coindexing with the subject if the subject is pro. In case(d), pro is forbidden in object position when the subject is a lexical NP, again suggesting that the GCR requires a pro to be indexed with nearest lexical NP.

Thus we see that we can account for both topicalized and simple Navajo transitive sentences using Huang's GCR plus DJR, if we assume that the "closest nominal element" for Navajo includes lexical NPs, but that empty pronominals do not count for the GCR.

4.5.3 The GCR vs. Platero's Parsing Strategy

Huang's GCR and Platero's NP-PRO constraint are almost identical. As mentioned above, Platero rejected an NP-PRO constraint analysis of Navajo in favor of a discourse interpretive rule.

The cases that lead Platero to reject the NP-PRO constraint will be reviewed below. The two sets of facts to be considered involve NP's

However, if we suppose that the possessive clitic pronoun bi-¹⁶ may be + or - argument, then we need not assume the existence of PRO in these examples. Thus the presumed counterexample is not a problem because its S-structure is as shown in (4.51)

(4.51) ashkii [NP_{bi} zhé'élé] yiyiltsá
 boy his father saw
 'The boy saw his_{i,j}/her father'

The pronoun bi must be free in its governing category, which it is, since its governing category in this case is the NP.

The only remaining set of apparent counterexamples to the NP-PRO constraint are those cases discussed in detail above; the sentences with internally-headed relative clauses. These appear to violate the parsing constraint by allowing empty objects with yi-verb forms.

Let us go through the set of possible readings for each parsing of this sentence and consider the implications for the adaptation of Huang's theory which we proposed in the previous section.

Case (s): pro [man horse roped]-rel branded

In this parsing, pro is the subject of branded, and [man horse roped]-rel is the object of branded. Either man or horse may be interpreted as the head of the relative clause. Huang's GCR would not

16. This is the only form of the third person possessive pronoun; there is no yi-form

apply to pro in this case, since none of the lexical NPs c-commands pro. Therefore, pro is free to refer outside of the sentence. Since pro is free, we could also get the case where pro and man happen to corefer, but only if we assume that Condition C of the binding theory does not hold for Navajo. As discussed above, this is a problem which is made even more severe by the puzzling fact that pro, being free, ought to be able to refer to the embedded object, but it cannot. Under a Huang-style analysis, we would have to supplement the definition of "closest nominal element" in Navajo in the following way:

CLOSEST NOMINAL ELEMENT(Navajo) X is the closest nominal element to Y iff X is a lexical NP, and

X c-commands Y

OR

if there is no NP that c-commands Y,

X is string-adjacent to Y.

Case b): man [[pro horse roped]REL] branded

This parsing is completely well-behaved with respect to the NP-PRO constraint; pro must be coreferent with the subject of the sentence, no matter which NP is chosen as the head of the relative clause. We see then that any reading in which the embedded subject, pro, is the head of the relative clause can be ruled out as a condition B violation, because this pro is coindexed with the matrix subject.

Case c): [[man horse roped] REL] pro branded

This is the case that Platero considers to be evidence against the existence of the NP-PRO constraint. He argues that since empty objects seemed to be ruled out in the simple cases by a combination of the

NP-PRO constraint and the principle of disjoint reference (binding principle B), the same constraints should conspire to rule out this interpretation.

Platero is careful to show that it would be wrong to suppose that this parsing actually is ruled out, and its apparent availability is only due to the fact that there are two possible English translations of parsing b. Although Platero notes that the judgements on this parsing are difficult to elicit, he provides additional evidence that the representation must exist. If the NP with which pro is coreferent is a proper name, parsing b is unavailable, since proper names cannot head relative clauses, yet the sentence is still grammatical.

(4.52) Asdzáán Kii ya'nírtsoodéé yich' anóóshkeed
 woman Kii 3-fed-3-REL 3-scolded-3

*The woman scolded Kii who she fed.

The woman who fed Kii_i scolded him_{i,*j}

(Platero 1982:293)

Platero's other piece of evidence that the representation with a relative clause subject and empty object must be available is even more conclusive. Headless relatives with bi-verbs, unlike those with yi-verbs, are unambiguous as to which NP is to be construed as the head.

(4.53) a) $\begin{matrix} \{i\} \\ \{j\} \end{matrix}$ dzaanééz yízt at-éé
 horse mule yi-bit-REL

'The horse that kicked the mule' OR

'The mule that the horse kicked'

b) $\begin{matrix} \{i\} \\ \{j\} \end{matrix}$ dzaanééz bízt ar-éé
 horse mule bi-kick-REL

'The horse that was kicked by the mule'
 *'The mule that the horse was kicked by'

If we embed such a relative clause under another verb, we can get only the reading in which there is an empty object.

(4.54) ɪíí' dzaanééz bi zt aṭ-éé yishxash
 'horse mule bi-bit-REL yi-bit

'The horse that was kicked by the mule_i bit it_i
 *'The horse bit the mule that it was kicked by'

Such evidence that there must exist a parsing of relative clauses in which there is an empty object leads Platero to abandon the NP-PRO constraint in favor of the discourse interpretation rule. We can see that this sentence also violates the Huang-style account that we have proposed so far, since the nominal with which the pro ends up coindexed neither c-commands pro nor is string adjacent to pro.

Since the existence of this parsing for a sentence containing an internally-headed relative clause is the only piece of evidence against the NP-PRO constraint, a possible solution to the problem might be to exempt relative clauses from the NP-PRO constraint. Notice that at S-Structure, an internally-headed relative clause has just the overt structure of an S', not of an NP. Perhaps these relative clauses do not count as a Closest Possible Nominal.

In the cases that Platero considered problematic, the object pro is obligatorily controlled by a NP which does not c-command it. Therefore it meets the binding requirement, since it is not coindexed with a c-commanding antecedent. It also meets the control requirement, since

it is coindexed with the closest nominal element.

However, because of the parallelism constraints found in the interpretation of the empty pronominals, this option is inadequate. If relative clauses were exempt from the NP-PRO Constraint, or if Navajo simply didn't have a c-command requirement as part of its control rule, coindexation of pro with the other nominal element should also be permitted; the only coindexing that should not be permitted is coindexing with the NP which is construed as the head of the relative clause, since percolation of features of the highest NP node would cause pro to be bound. However, the following sentence is not grammatical:

(4.55) ashkii_i a'leéd yiyilitsanéé pro_i yizts'qs
 boy girl saw-REL kissed

'The girl who the boy_i saw kissed him_i'

Platero was assuming that any coindexing of pro constitutes binding. However, as has been pointed out in Chomsky (1984 class lectures and elsewhere), it appears that the structural requirements for binding and control are quite different. Binding clearly requires c-command, whereas control may require simple precedence. As a last resort, let us try to maintain an account in terms of the GCR and DJR by revising our definition of "closest nominal element" in Navajo.

(4.56) CLOSEST NOMINAL ELEMENT (Navajo) for X = first lexical NP preceding X in the string

This definition seems maximally simple, yet notice that we must now state a language-specific addendum to the Generalized Control Rule for

Navajo.

(4.57) GCR: Coindex an empty pronominal with the closest nominal element.

(Navajo only): if there is no closest nominal element, an empty pronominal may optionally be coindexed with an immediately following nominal element.

DJR: A pronoun must be free in its governing category.

This rule is completely ad-hoc, and furthermore, it seems that the original problem that Platero set out to solve is still unsolved on this account: i.e. why must a null subject be (either free or) coindexed with an embedded subject and a null object with an embedded object?

Furthermore, if we look at constructions other than relative clauses, we find that this hypothetical control rule gives entirely wrong predictions. In a sentence like (4.58), which contains an adjoined clause, we see that coindexing for control cannot operate on a simple linear string. The above control rule would predict only the a reading, when both a and b are perfectly grammatical.

(4.58) Hastiin deezghal-go nídii'na'
man he awoke-COMP he got up

a) 'When the man_i awoke, he_i got up.'

b) 'When the man_i awoke, He_j got up.'

(Platero 1978:15)

Coordinate constructions also fail to obey the above control rule:

(4.59) Ashkii & 'ééd yí'déesol dóó hastiin yiyiitsá dóó deezgo!
boy girl whistled & and man saw and fell

'The boy_i whistled at the girl, he_i saw the man and he_i fell.'

(P 1978:66)

Platero's insightful observation was that no matter how the sentence is parsed, the NP which is string-closest to the verbs must be the object of both verbs. So, surprisingly, reading (4.15j), repeated here, is impossible.

- 4.15 [[man horse roped]_{ee}] pro branded
 h) 'The man who roped the horse_i branded it_i'
 i) *him/her_j
 j) *The horse that the man_i roped branded him_{i,j}.

It is precisely this observation which is captured by the ATB account presented in section 2.

4.6 On Mapping Conventions

If Platero's rule for interpreting grammatical relations (the IGR) is particular only to Navajo, we have reason to be suspicious of its existence. However, Woolford (1986) proposes that "it is not necessary to appeal to extragrammatical processing strategies or global constraints on transformations to account for data of this sort...if one fairly simple parameterized subsystem, Mapping, is added...Mapping Conventions place restrictions on the association of lexical items with terminal nodes in constituent structure trees at S-Structure." (1986:301) The Mapping Conventions which she proposes are given in (4.60).

(4.60) PARAMETERIZED FORMULATION OF MAPPING CONVENTIONS

- A. Each lexical item in the string must be mapped to/associated with

a unique terminal α S-Structure.

B. No association lines may cross.

C. Mapping proceeds in a strictly unidirectional manner with respect to terminal nodes within the same mapping domain, unless this would violate Convention A or B, or unless mapping is blocked by a qualifying feature clash (determined in each language on the basis of positive evidence).

(1986:322)

MAPPING DOMAIN: Two nodes x and y are within the same mapping domain if x^{max} and y^{max} are contained in all of the same maximal projections (assuming that VP is not a maximal projection, or if it is, excluding VP.). (1986:305)

The idea, then, is that mapping conventions constrain the particular S-Structures which may be related to PF strings of words, disallowing empty nodes in positions where a mapping domain would be interrupted. Woolford gives evidence from English, French, Irish and Toba Batak to argue that such an conventions may apply in parameterized forms cross-linguistically. many languages. This is an interesting approach to the problem of relating phonetic strings to S-Structures, however, I believe that there are empirical as well as conceptual problems with it. I will discuss the empirical problems which have to do with Navajo, and then will argue that the constraints on the positions of empty elements which Woolford claims are due to the Mapping conventions are independently available without such conventions. Thus, I support Woolford's claim that extragrammatical devices are unnecessary, and I dispense with special mapping conventions as well.

The first problem to be address has to do with the treatment of the 'yi/bi' alternation in Navajo. Although Woolford presents the

following paradigm¹⁷ to illustrate the need for a set of Mapping conventions for Navajo, she provides an explicit account for the sentences in (4.61), but does not do so for the sentences in (4.62).

(4.61) a. ashkii a'éeéd yizts'qs
 boy girl 3-kissed-3
 'The boy kissed the girl'

b. [_{NP}^e] a'éeéd yizts'qs
 girl 3-kissed-3
 'He/she kissed the girl'

c. [_{NP}^e] [_{NP}^e] yizts'qs
 3-kissed-3
 'He/she kissed him/her'

d. *a'éeéd [_{NP}^e] yizts'qs
 girl 3-kissed-3
 NOT: 'The girl kissed him/her'

(4.62) a. ashkii a'éeéd bizts'qs
 boy girl 3-kissed-by-3
 'The boy was kissed by the girl'

b. [_{NP}^e] a'éeéd bizts'qs
 girl 3-kissed-by-3
 'He/she was kissed by the girl'

c. [_{NP}^e] [_{NP}^e] bizts'qs
 3-kissed-by-3
 'He/ she was kissed by him/her'

17. I am maintaining Woolford's glosses here, although as discussed earlier, the bi forms are not really passive, and the prefix order within the verbal complex is O..S..stem

- d. * α' ééd [_{NP}^e] bizts'qs
 girl 3-kissed-by-3
 NOT: 'The girl was kissed by him/her'

The mapping conventions are supposed to operate from right to left in all of the above sentences, ruling out any case in which an empty element appears between an overt NP and the verb. Woolford illustrates the operation of the mapping conventions in simple sentences with the yi-verb cases, where the mapping conventions serve to rule out empty pronominal objects in the presence of an overt subject.

In the bi-verb sentences, the word order is Object, Subject, Verb. This means that in a sentence with a bi-verb and only one overt NP, the NP must be construed as the subject. This fact is somewhat obscured by Woolford's translations of the bi-sentences as passives. If we instead follow Perkins (1978) in translating bi-sentences as actives, but with different emphases, the above bi-sentences will be translated as (4.63) and.

- (4.63) a. ashkii α' ééd bizts'qs
 boy girl bi-kissed
 'The girl kissed the boy; (talking about the boy)
- b. [_{NP}^e] α' ééd bizts'qs
 girl bi-kissed
 'The girl kissed him/her' (talking about him/her)
- c. [_{NP}^e] [_{NP}^e] bizts'qs
 bi-kissed
 'He/ she kissed him/her'
- d. * α' ééd [_{NP}^e] bizts'qs
 girl 3-kissed-by-3
 NOT: 'He/she kissed the girl' (talking about the girl)

If these are the correct translations, then we must discover a way to prevent the mapping shown in (4.64).

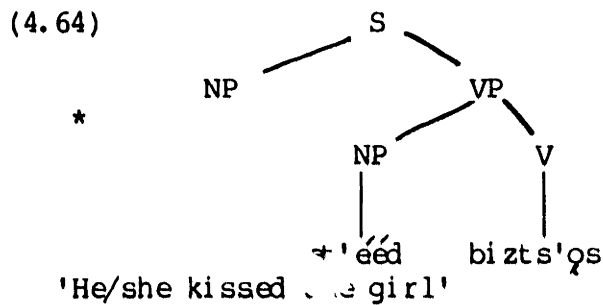

One possibility would be to assume that there is a trace in object position in the bi-constructions, which is visible to the mapping conventions, and therefore is mapped onto the object position, as shown in (4.65).

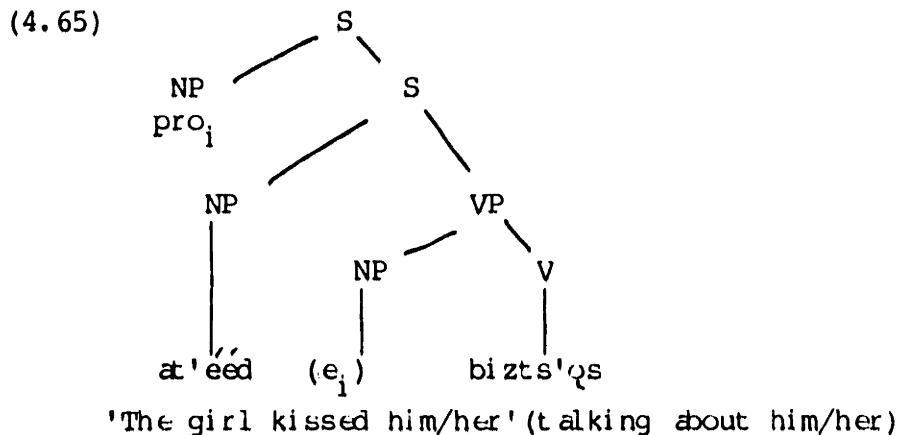

However, this is precisely the analysis which I proposed above for simple sentences, following the proposals of Huang in which traces were acceptable object gaps but pronominals were not. That account did not need any extra mapping conventions; the appearance of empty pronominal objects was prohibited by independent principles of binding and control. In Woolford's system, these principles of binding and control are also independently necessary; I maintain that they provide an

account for the cases for which her mapping conventions are designed.

Notice further, that for the mapping of the bi-cases to work in Woolford's system, the trace in object position in bi-sentences must be an NP trace, left in an uncase-marked position, rather than a WH trace. This is because WH traces are not visible to the mapping conventions, according to Woolford. However, there is little if any evidence that the movement involved in bi-sentences involves absorption of accusative case. For one thing, the subject shows no sign of losing its theta role, and also, Navajo has a different construction which is more correctly translated as passive.

Thus, it seems that the bi-verb are best accounted for without mapping conventions, and since these were the very cases that originally suggested such conventions, we must question the necessity of the mapping component.

As further evidence that the mapping conventions really only serve to rule out empty pronominal objects, which ought to be ruled out by independent principles of binding and control, consider how the mapping

conventions work in (4.66) (Woolford's (4a)):

(4.66) æshkii [NPe] æ't'æéð yi yi iits ænéé yizts'qs
 boy girl saw-REL kissed
 'The boy_i kissed the girl that he_i saw'

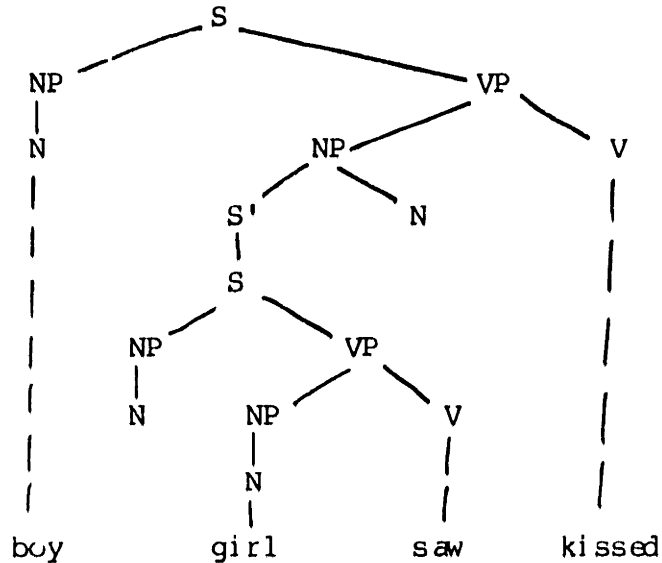

The mapping conventions state that mapping proceeds right to left within each mapping domain. The important fact to notice here is that although the two NP nodes within the relative clause are in the same mapping domain, there is no requirement that they both be associated with an NP. In this regard, the mapping conventions are strikingly different from phonological mapping rules, which are generally thought to obey a well-formedness condition which states that on any given cycle, each element on one tier is associated with at least one element on the other. The mapping conventions, on the other hand, may stop before they reach the last phonetic NP and the last NP node in a mapping domain. Considering the extent to which the effects of the mapping principles parallel the effects of independent binding and control principles, it is undesirable to propose a set of rules which

are of a familiar sort but which apply in an unexpected way.

Another conceptual objection to the introduction of a mapping component has to do with the status of the trees onto which lexical items are mapped by Woolford's conventions. In her explication of the proposal, she maps ordered strings of lexical items onto trees which contain category information. However, if the work of Stowell (1981) and others is correct, then the base component does not generate any trees with category information contained in them; rather category information percolates from lexical items. Furthermore, as was discussed in Chapter 1, the surface order of lexical items is currently thought to follow from parameters of theta role assignment and case assignment along with parameterized adjacency requirements on theta and case assignment. In GB theory, strings of words have their surface order in virtue of these parameters on the assignment of structural relations. A proposal to map ordered strings of words onto structures is thus not in keeping with current assumptions.

The issues involving the relationship of phonetic form to syntax are far from clear. The interesting thing about Huang's approach is that he provides independent evidence for the existence of the abstract topic positions. If these positions are independently motivated and serve to explain the data, then additional principles are unnecessary.

4.7 Formal Properties of ATB Representations

In my Across-the-Board account of the Navajo facts, I was intentionally vague about the precise nature of the ATB representations that I was using. In this section, I will explore some possible sources of these effects.

4.7.1 The Coordinate Structure Constraint

The ATB format proposed by Williams was designed to capture the observation made by Ross (1967) that the Coordinate Structure Constraint (4.67) could be violated in some cases.

(4.67) COORDINATE STRUCTURE CONSTRAINT

In a coordinate structure, no conjunct may be moved, nor may any element contained in a conjunct be moved out of that conjunct.

This constraint may be circumvented by applying some transformational rules to conjoined structures "across-the-board", which means that if the rule applied to one conjunct, it obligatorily applied to all conjuncts. While the Coordinate Structure Constraint ruled out the b cases below, in which extraction has taken place out of one conjunct, the a cases are grammatical, because extraction has taken place "across-the-board".

- (4.68) a. Tom picked, and I washed, and Suzie will prepare, these grapes. (=Ross's 4.120b)
b. *Tom picked, and I washed some turnips, and Suzie will prepare, these grapes. (=Ross's 4.121b)

- (4.69) a. When did you get back and what did you bring me? (Ross's 4.138 a)
 b. *Sally's sick and what did you bring me? (Ross's 4.139 a)

Although Ross had little to say about the formal properties of such rules, he pointed out that "across-the-board rules operate in such a way as to remove elements from conjuncts, while rules like passive, particle movement, extraposition, and many others like them which could be cited merely rearrange items within a conjunct." (1967:178) ¹⁸

4.7.2 Williams (1978) ATB Format

To capture the ATB effects noticed by Ross, Williams proposed "that conjuncts in a coordinate structure be written on top of each other, and that factor lines that split coordinate structures be drawn so as to split all conjuncts of that structure." (1978:32) The D-Structure of

18. Ross also noticed certain non conjoined cases that show partial ATB effects:

- (i) a. Sasha is gobbling down blintzes faster than I can reheat them. (=Ross's 4.154 a)
 b. ??The blintzes which Sasha is gobbling down faster than I can reheat are extremely tasty, if I do say so. (=Ross's 4.155 a)
 c. * I think Anita may have poisoned the fishballs which Sasha is gobbling down blintzes faster than I can reheat. (=Ross's 4.159 a)
- (ii) a. I want to peruse that contract before filing it away. (=Ross's 4.154 b)
 b. ?I suspect that the contract which I wanted to peruse before filing away may have some loopholes. (=Ross's 4.155 b)
 c. *The deed which I want to peruse that contract before filing away is probably a forgery. (=Ross's 4.159 b)
- (iii) a. Fred tore the curtain in rolling it up. (=Ross's 4.154 c)
 b. The curtain which Fred tore in rolling up was the kind gift of my maternal Aunt Priscilla. (=Ross's 4.155 c)
 c. *The wallpaper which Fred tore the curtain in rolling up had a pleasing geometrical pattern. (=Ross's 4.159 c)

the indirect question (4.70), then, looks like (4.76).

(4.70) who John saw and Bill hit

(4.71) COMP [John saw who]_S
and
[Bill hit who]_S

Descriptively, if an element is extracted out of one sentence, the parallel constituent must also be extracted out of the other sentence. Williams proposes to achieve this result by stating that the grammar includes a definition of the ATB format as in (4.72), and that the usual definition of factor¹⁹ may be modified by adding (4.73).

(4.72) DEFINITION

The structure
[X₁]_{c₁}
:
:
[X_n]_{c_n} and

is a well-formed labeled bracketing if X₁, ..., X_n are.

(4.73) If F is a factor and C a coordinate structure containing conjuncts C₁...C_n, then for F to be a well-formed factor the following must hold:
if for any i, [C_i F and]_{C_i} F,
then for all i, it must be the case that
[C_i F and]_{C_i} F

Williams' definition of a well-formed labeled bracketing stipulates

19. The usual definition of factor for Williams is that given by Peters and Richie(1973), who define factor as any substring of a well-formed labeled bracketing that does not begin with a right bracket or end with a left bracket.

Kupin's theory, which was outlined in Chapter 1 allows a type of phrase marker which is called a Reduced Phrase Marker (RPM). An RPM is a group of sets including one terminal string and several "monostrings". Each monostring is made up of one non-terminal plus all of the terminals which are not dominated by that non-terminal.

In Lasnik and Kupin's theory, the definition of an RPM includes conditions which stipulate that given any two monostrings, either one precedes the other or one dominates the other.

(4.75) \mathcal{P} is an RPM if there exist A and z such that $A \in \mathcal{P}$ and $z \in \mathcal{P}$ and if $(\Psi, \varphi) \subseteq \mathcal{P}$,

either Ψ dominates φ in
 or Ψ dominates φ in
 or Ψ precedes φ in
 or Ψ precedes φ in

(Lasnik and Kupin

1977)

It is this condition that Goodall proposes to relax. First, he examines the evidence for such a restriction, and determines that the restricted definition of monostring may be replaced by a definition which states only that some portion of the terminal string must bear the "is α " relation to each monostring. He replaces the above definition with (4.76).

(4.76) \mathcal{P} is an RPM if there exist A and z such that $A \in \mathcal{P}$ and $z \in \mathcal{P}$ and if for $\varphi, \psi \in \mathcal{P}$, $\varphi \notin \Sigma^*$, there exists y, such that y is α φ in \mathcal{P} .

(Goodall 1984.21)

This allows monostings for which neither a dominance nor a precedence relation holds. Phrase markers which include monostings bearing neither a dominance nor a precedence relation to one another are, Goodall claims, three dimensional; that is, they may be parallel.

Goodall proposes that ATB extraction effects are a result of the fact that coordination involves a union of the 'parallel' phrase markers. Any phrase marker is a set of relations between terminal and non-terminal elements; if we take the union of two phrase markers which have identical non-terminal elements and relations, and differ only in their terminal strings, the result is one set of non-terminal and relations and two sets of terminal strings. In other words, the union of two conjuncts which have the same structure but different words will be two strings of words with one structure.

First, I will give the examples which Goodall uses to illustrate how union of phrase markers works when the phrase markers are stated as RPMs. Then, I will make clear the fact that a union operation may be performed on the sort of phrase markers discussed in Chapter 1 as well.

Goodall uses the following sentence as an example:

(4.77) John sleeps and eats doughnuts.

In a "union of phrase markers", "the RPM contains at least two discrete subsets, each of which is a sentence." (Goodall 1984:55) The above sentence contains two underlying sentences, given in (4.78). The RPMs for these sentences are given below, followed by the union of

these two RPMs. Notice that in the union RPM, Goodall treats any non-terminals which dominate at least some of the same terminals as nondistinct. In this particular case, the non-terminals which dominates some of the same material S, which dominates the subject NP, and the Subject NP itself, which dominates John in both sub-phrase markers.

- (4.78) a. John sleeps.
 b. John eats doughnuts.

- (4.79) a. { S, NP sleeps, John VP¹, John sleeps }
 b. { S, NP eats doughnuts, John VP², John V doughnuts, John eats NP, John eats doughnuts }

- (4.80) a. { S, NP sleeps, John VP¹, John sleeps, NP eats doughnuts, John VP², John V doughnuts, John eats NP, John eats doughnuts }

The union RPM contains pairs of monostings which satisfy neither dominates nor precedes. Goodall makes this clear by listing all of the pairs of monostings in the union RPM, and pointing out which pairs satisfy which predicates. In (4.81), I reproduce his list, indicating those pairs which satisfy dominates with D and those which satisfy precedes with a P.

- | | | | | |
|--------|----|---|----------------------|---|
| (4.81) | a. | S | NP sleeps | D |
| | b. | S | John VP ¹ | D |
| | c. | S | John sleeps | D |
| | d. | S | NP eats doughnuts | D |
| | e. | S | John VP ² | D |

f. S	John V doughnuts	D
g. S	John e a s NP	D
h. S	John e a t s doughnuts	D
i. NP sleeps	John VP ¹	P
j. NP sleeps	John sleeps	D
k. NP sleeps	NP e a s doughnuts	
l. NP sleeps	John VP ²	P
m. NP sleeps	John V doughnuts	P
n. NP sleeps	John e a s NP	P
o. NP sleeps	John e a s doughnuts	
p. John VP ¹	John sleeps	D
q. John VP ¹	NP e a s doughnuts	P
r. John VP ¹	John VP ²	
s. John VP ¹	John V doughnuts	D
t. John VP ¹	John e a s NP	D
u. John VP ¹	John e a s doughnuts	D
v. John sleeps	NP e a s doughnuts	
w. John sleeps	John VP ²	D
x. John sleeps	John V doughnuts	
y. John sleeps	John e a s NP	
z. John sleeps	John e a s doughnuts	
aa. NP e a s doughnuts	John VP ²	P
bb. NP e a s doughnuts	John V doughnuts	P
cc. NP e a s doughnuts	John e a s NP	P

dd. NP eats doughnuts	John eats doughnuts	D
ee. John VP ²	John V doughnuts	D
ff. John VP ²	John eats NP	D
gg. John VP ²	John eats doughnuts	D
hh. John V doughnuts	John eats NP	P
ii. John V doughnuts	John eats doughnuts	D
jj. John eats NP	John eats doughnuts	D

The pairs which fail to satisfy either precedes or dominates are repeated in (4.82)

(4.82) k. NP sleeps	NP eats doughnuts
o. NP sleeps	John eats doughnuts
r. John VP ¹	John VP ²
v. John sleeps	NP eats doughnuts
x. John sleeps	John V doughnuts
y. John sleeps	John eats NP
z. John sleeps	John eats doughnuts

In Goodall's theory, ATB exceptions to the coordinate structure constraint are due to the general principle barring vacuous quantification. Since each coordinate in a conjoined construction is a separate sub-sentence, when a WH-word has been fronted to a COMP node which the two sub-sentences have in common, there must be a gap in each sub-sentence. So, for example, (4.83) is ungrammatical because one of the sub-sentences of which it is composed, shown in (4.83b and c), is ill formed by the general principle of No Vacuous Quantification.

- (4.83) a. *Who does John like and Bill hates Mary?
b. Who does John like
c. *Who does Bill hate Mary

Goodall's work raises various questions about coordinations which have lain relatively dormant within GB theory. Some of these have received extensive attention within alternative frameworks, as well as within the Standard Theory and other precursors to GB. The literature on coordination in the GPSG framework is particularly interesting, but discussion of this work is beyond the scope of the present investigation. In the remainder of this section, I will simply mention some potentially problematic aspects of Goodall's proposal which will be relevant for the subsequent discussion of the Navajo case.

One aspect of Goodall's proposal which is still not clear is what makes two tokens of some particular nonterminal or terminal 'the same'. In particular, the S nodes are considered to be the same because they both dominate the NP subjects which in turn both dominate the terminal John. It appears to be the case that the two tokens of the word John can only be taken to be the same if they are coreferent. However, it is not obvious that we can stipulate that two words in a coordinate construction may be 'the same' if they have the same phonetic form and are coindexed. Consider the sentences in (4.84):

- (4.84) a. The students are reading.
b. The students are working at the blackboard.
c. The students are reading and working at the blackboard.
d. Some students are reading.
e. Some students are working at the blackboard.
f. Some students are reading and working at the blackboard.

The coordinate sentences, c and f, are ambiguous between a reading in which it is the same students who are both reading and working at the blackboard, and a reading in which some students are reading while others are working at the blackboard. The latter reading ought to be impossible if the coordinate sentence underlyingly contains separate but coindexed subject NPs.

However, it is quite obvious that some sort of coextension is required of two constituents which are 'collapsed' in a coordinate construction. It is necessary to prevent a sentence like (4.85a) from being derived from the two sentences (4.85b) and (4.85c).

- (4.85) a. Ronald_i gave Nancy an expensive fur.
 b. Ronald_j gave the kids free Egg McMuffins.
 c. Ronald_? gave Nancy an expensive fur and the kids free Egg McMuffins.

Goodall used the formalism of RPMs to express his proposal, because it is both explicit and restrictive. However, it is clear that a union operation may be performed within any formalization in which a phrase marker is a set of terminals and non terminals.

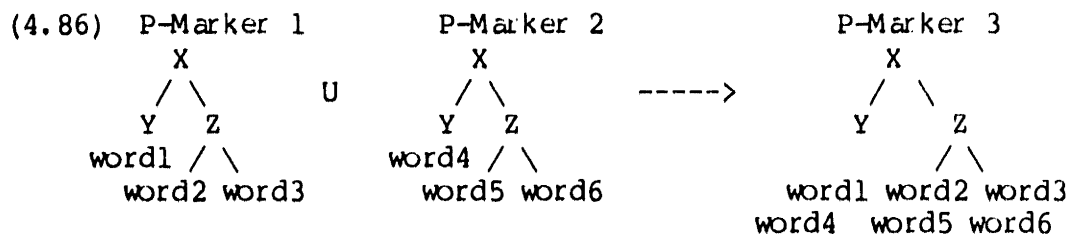

Since there is only one phrase marker, a movement operation, which affects structure, cannot move one terminal element without moving the other. If extraction is an operation on structure, and if ATB effects

are the result of some constraint on extraction, then it is clear that once two phrase markers have undergone union, movement of an element in one conjunct automatically requires movement of the parallel element in the other conjunct.

4.7.4 ATB Effects in Non-Coordinate Constructions

In several recent studies, ATB accounts have been proposed for constructions other than Coordination. In order to discover which kinds of constructions show ATB effects, let us consider the proposals which have been made so far.

Huybregts and van Riemsdijk (1984) investigate two types of possible parasitic gap constructions and find that while Dutch allows parasitic gaps in infinitival adjuncts like (4.87), it does not allow them in finite adjuncts, nor in cases of the type the man that anyone who knows admires.

- (4.87) Welke artikelen heeft hij [zonder PRO e te lezen] opgeborgen?
which articles has he without to read filed
'Which articles has he filed without reading?'

The problem which they address is the fact that although Dutch disallows two out of three possible types of parasitic gap constructions, it allows what look superficially like parasitic gaps in constructions where they would be disallowed in both Scandinavian and English:

- (4.88) Hij heeft deze artikelen [zonder PRO e te lezen] opgeborgen?
He has these articles without to read filed

What Huybregts and van Riemsdijk suggest is that these two Dutch sentences do not actually involve parasitic gaps; rather, these are across-the-board gaps. The use a version of the Williams (1978) formalism to illustrate the ATB effects in these sentences.

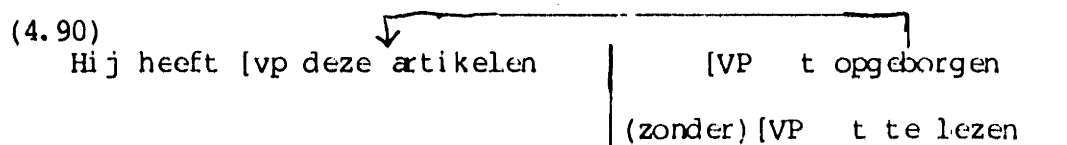
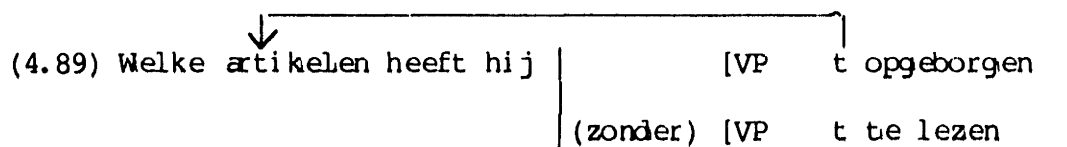

Whereas Huybregts and van Riemsdijk maintain that Dutch differs from English in that English lacks the sort of ATB constructions which have a surface resemblance to real parasitic gap constructions, Haik (1985) argues that English parasitic gaps are ATB constructions. She claims that there exists a type of LF movement which creates ATB constructions by means of the identification of the moved category with its target. In her theory, parasitic gaps become ATB gaps at LF, and the properties of sloppy identity and pronouns of laziness constructions can be explained without appeal to lambda-extraction. Notice that the restrictions on the interpretation of gaps and bound pronouns in these constructions show ATB-like effects.

- (4.91) SLOPPY IDENTITY (obtains only in coordinate constructions)
- a. Tom told Bill about his book, and Peter did too.
 did = told Bill about Tom's book
 OR did = told Bill about Peter's book
 - b. The woman who put her paycheck in the bank was wiser

than the woman who cashed it.

(4.92) PARASITIC GAPS

- a. This is the report that Sue filed e after reading e.
- b. Sue is the one who e filed the report after e reading it.²⁰
- c. *This is the report that Sue filed e after e was finished.

Håk proposes that certain non-coordinates which contain bound pronouns are quantificational (at least at LF) due to the presence of the bound pronoun. She suggests that these constituents undergo a sort of QR at LF, in which they are identified with their target, undergoing Node merger which yields a structure in which subtrees are represented on distinct planes.

(4.93) UNION OF LIKE NODES

- (i) Merge X, where X is a topmost node of a structure A and that of a structure B, and X is the same category in A and B.
- (ii) Iteration of (i) down the tree is possible if X dominates the same terminal in A and B.
- (iii) Merging a maximal projection is merging of all the projections of that node, from head to maximal projection.
(Håk 1985.242)

4.7.5 Other Parallel Constructions

In this section, I present data from two languages which are unrelated to Navajo, but which exhibit curious parallelism effects in

20. This sentence, in which both the object of filed and the subject of reading are independently licensed, is included here simply to fill out the paradigm. Also, the fact that the PRO subject of reading is controlled by SUE may be an ATB effect.

the interpretation of Grammatical Relations.²¹ While I am unable to provide a thorough enough analysis of these two languages to be sure that the parallelism effects that they show arise from the same source as those observed in Navajo, the data suggest that the present work has brought a regularity to light which may be found in other languages. The correct account of the parallelism effects displayed by the data to be presented in this section awaits much more extensive knowledge of the syntax of Bella Coola and Hopi, and their possible similarities to and differences from Navajo, as well as a deeper understanding of the properties of parallel structures in the better-understood languages.

4.7.5.1 Bella Coola

Davis and Saunders(1984) give a set of facts from the Salish language Bella Coola which show an interesting similarity to the Navajo facts which we have been discussing. They notice that in Bella Coola, "the coreferential relationship signaled by elision is subject to a principle of parallelism...if the PARTICIPANTS are syntactically manifest as X-then-Y in one portion of the utterance, then they must parallel that sequence in the other if elision is to be employed as the mark of coreference.."(1984.160)

According to Davis and Saunders, Bella Coola simple sentences "can be conveniently be described as VSO. Referential arguments may be expressed by means of an NP, as in (4.94a), a nominalized verb, as in

21. I am grateful to Ken Hale for bringing these data to my attention.

(4.94b), a pronoun, as in (4.94c) or by only the agreement on the verb, as in (4.94d).

- (4.94) a. *ikm-Ø ti-nus'ulX-tx
 run-he thief
 'The thief is running'
- b. *ikm-Ø ti-'ulX-t-tx
 run-he steal-he/it
 'The one who stole it is running'
- c. *ikm-Ø tx
 run-he he
 'He's running'
- d. *ikm-Ø
 'He/she/it is running'

(Davis and Saunders 1984.150)

The particular construction which Davis and Saunders is given with all arguments overt in (4.95).

- (4.95) sp̄ix^w-is ti-'imlk-tx ti-nus'ulX-tx ka-kx-is ti-'imlk-tx ti-nus'ulX
 hit-he/him man thief unr-see-he/him man thief
 'The man will hit the thief if/when the man sees the thief'

The parallelism constraint can be seen if we examine the possible interpretations of sentences in which one of the arguments of the second clause in the above sentence is null. Consider the three sentences given in (4.96). The appropriate possible and impossible interpretations are given for each.

- (4.96) sp̄ix^w-is ti-'imlk-tx ti-nus'ulX-tx ka-kx-is ti-nus'ulX-tx
 hit-he/him man thief unr-see-he/him thief

'The man_i will hit the thief_j if/when he_i sees the thief_j'

NOT: 'The man_i will hit the thief_j if/when the thief_j sees him_i'.

'He_i will hit the thief_j if/when the man_i sees the thief_j'

NOT: 'The thief_j will hit him_i if/when the man_i sees the thief_j'

(4.101) sp̄iX^w-is ti-'imlk-tx ka-kx-is ti-'imlk-tx ti-nus'ūlx-tx
hit-he/him man unr-see-he/him man thief

'The man_i will hit the him_j if/when the man_i sees the thief_j'

NOT: 'He_j will hit the man_i if/when the man_i sees the thief_j'

Interestingly, the parallelism effect seems to be induced by the repetition of one of the NPs. When one clause contains two overt NPs and the other contains one null pronominal and one NP distinct from those in the other clause, as shown in (4.102), the sentences obey what Davis and Saunders call a "principle of phoric coreference".

(4.102) sp̄iX^w-is ti-'imlk-tx ti-nus'ūlx-tx ka-kx-is ti-'immīki-tx
hit-he/him man thief unr-see-hc/him boy

'The man_i will hit the thief_j if/when he_i sees the boy'

NOT: 'The man_i will hit the thief_j if/when the boy sees him_i'

NOT: 'The man_i will hit the thief_j if/when the boy sees him_j'

NOT: 'The man_i will hit the thief_j if/when he_j sees the boy'

(4.103) sp̄iX^w-is ti-'immīki-tx ka-kx-is ti-'imlk-tx ti-nus'ūlx-tx
hit-he/him boy unr-see-he/him man thief

'The boy will hit him_j if/when the man_i sees the thief_j'

NOT: 'The boy will hit him_i if/when the man_i sees the thief_j'

NOT: 'He_i will hit the boy if/when the man_i sees the thief_j'

NOT: 'He_j will hit the boy if/when the man_i sees the thief_j'

(4.104) PRINCIPLE OF PHORIC COREFERENCE:

- a. Where the principle of parallelism fails to resolve ambiguity uniquely, a leftward-referring elision is possible only when it is an EXECUTOR.
- b. Where the principle of parallelism fails to resolve ambiguity uniquely, a rightward-referring elision is possible only when it is an EXPERIENCER.

It should be noted that Davis and Sanders say that the parallelism principle (and the principle of phoric coreference) hold only when the sentence would otherwise be ambiguous. If number or gender marking would disambiguate a sentence containing a null pronominal, then the special coreference principles are not in effect.

(4.105) a. $\text{sp}^{\text{w}}\text{-tis}$ $\text{ti-}'\text{imlk-tx}$ $\text{wanus}'\text{ulXuks-c}$ kakx-it $\text{ti-}'\text{imlk-tx}$
hit-he/them man thieves unr-see-they/him man
'The man_i will hit the thieves_j if/when they_j see the man_i'

b. $\text{sp}^{\text{w}}\text{-it}$ wa-iimlkuks-c $\text{ti-nus}'\text{ulX-tx}$ kakx-it wa-iimlkuks-c
hit-they/him men thief unr-see-they/him man
'The men_i will hit the thief_j if/when he_j sees the men_i'

(4.106) 'ax^{w} yanix-is $\text{ti-}'\text{imlk-tx}$ ci-xnas-cx $\text{kax-}'\text{ax}^{\text{w}}$ $\text{-}^{\text{a}}\text{ap-s}$ 'at tx
neg like-he/her man woman unr-neg-go-she with-him
'The man_i won't like the woman_j if she_j won't go out with him_i'

4.7.5.2 Hopi

Hale, Jeanne and Platero (1978) discuss a constraint on the use of relative clauses which, at least on the surface, suggests a similarity to the Navajo case. The problem which they outline is this: In Hopi, when a relative clause is in subject position, the relative clause must be headed by the subject; a relative clause headed by the object

cannot function as a matrix subject. This is illustrated by the following contrast:²²

(4.107) 'itá-na mí-t tiyó'ya-t ní' (pí-t) tíwa:-qá-t hoóna.
 our-father that-OBL boy-OBL I (him-OBL) saw-QA-obvOBL sent home
 'My(lit., our) father sent home the boy whom I saw'

(4.108) *mí' tiyó'ya ní' (pí-t) tíwa:-qá-t pay níma.
 that boy I (him-OBL) home-QA-obv-OBL already went:home
 'The boy whom I saw has gone home.'
 (Hale et al. 1978:401)

An interesting fact brought to bear by Hale et al. is illustrated by (4.109), where an extraposed variant of the ungrammatical sentence above is grammatical.

(4.109) mí' tiyó'ya pay níma, ní' (pí-t) tíwa:-qá-t.
 that boy already went:home I (him-OBL) home-QA-obv-OBL
 (ibid..402)

Hale et al. attribute this phenomenon to case marking of the relative clause. Case marking of the nominal element qa is according to the following principles.

(4.110) QA CASE ASSIGNMENT

- a. [-obl] (/qá/): shared subjects, and relative NP is subject in its own clause
- b. "proximate" [+obl] (/qá-y/): shared subjects, and relative NP is nonsubject in its own clause
- c. "obviative" [+obl] (/qá-t/): otherwise
 (ibid.,:400)

22. OBL=Oblique case marking, obvOBL=obviative oblique, QA=a defective noun with no semantic content.

The case marking which qa receives when subjects are not shared is oblique, and this is incompatible with the requirement that subjects must be unmarked for case. In other words, when the relative clause is the subject, subjects must be shared.

4.7.6 The Navajo Case

In illustrating the ATB effects in Navajo relative clauses, I said vaguely that the embedded clauses were "pulled out" of the matrix clauses. In this section I will try to make more precise this intuitive notion of pulling the relative clause away from the matrix, in the hope that some insight will be gained into the source of ATB effects.

There are two related problems to be solved in order to explain the observed ATB effects.

1. We must determine what the structural relationship is between the relative clause and the matrix. Is the relative clause in an argument position at D-Structure and all other levels as well, it may be adjoined at D-Structure and all other levels, is it base-generated in an argument position and moved at some other level, or is it base-generated in an adjoined position?
2. We must determine the identity of the empty arguments in Navajo. We already know that variables in many languages must be interpreted Across-the-Board; but we do not know whether other empty (or overt) categories may also show such effects.

These two questions are related insofar as the answer to one may restrict the possible answers to the other. For example, if we suppose, following Haik, that the relative clause is extracted at Logical Form and adjoined to S in ATB format, then we may expect the gaps which must be parallel to be variables, since one of them is the trace of the extracted clause itself. If the gaps are variables, then we will look for the source of ATB effects in those principles which license variables.

Note that the discovery of some property of the Navajo constructions which suggests that the gaps are variables does not in and of itself constitute evidence that LF extraction has taken place, since there is substantial evidence (see Sells(1984) and references cited there) that A-bar bound pronominals are indistinguishable from variables.

4.7.6.1 Base Generation of Parallel Pronominals

Suppose that the ATB effect observed in Navajo is due to a special constraint on the coindexing of pronominal elements. What might be the source of this constraint?

An interesting piece of evidence that control may show ATB effects comes from the fact that in English, PRO within an argument clause may be controlled by the subject, by the object, or may be uncontrolled, while PRO in an adjoined clause is always controlled by the subject of whichever S it is adjoined to. These facts are illustrated by (4.111a-d).

- (4.111) a. Mary tried PRO to swim faster. PRO = Mary
 b. Mary told Kathy PRO to swim faster. PRO = Kathy
 c. Mary talked to Kathy about PRO swimming. PRO = arb
 d. Mary talked to Kathy before PRO swimming. PRO = Mary

Notice that it is the underlying subject which obligatorily controls the PRO subject of an adjunct:²³

- (4.112) a. The boat was sunk PRO to collect the insurance.
 b. The ice cream was put in the freezer before PRO leaving for the picnic.
 c. *The ice cream was put in the freezer before PRO melting.²⁴

The proposal that control in English adjuncts results from ATB coindexing of arguments at D-Structure makes an interesting prediction: If the above sentence is supposed to be ill-formed because the underlying object in the matrix is coindexed with the underlying (and surface) subject in the adjunct, then we would expect the sentence to improve if we coindex two underlying objects. In fact, it does, (4.113) is fully grammatical.

- (4.113) The ice cream was put in the freezer before PRO being eaten.

It is clear in these English cases that the apparent ATB effect holds of adjoined clauses and not of embedded ones. Furthermore, I argued in

 23. This generalization is clearly true for gerunds. The data in purpose clauses is less clear, because sentences like (i) may have been derived from (ii) by extraposition.

- (i) A man was called PRO to fix the sink.
 (ii) A man PRO to fix the sink was called.

24. There are grammatical surface strings which resemble this one but have different prepositions, but I think it can be shown that these are within the VP, acting as secondary predicates. An example of this type would be 'The ice cream was put in the freezer while PRO melting'.

Chapter 1 that there are independent reasons to believe that parallel representations are available only for adjunction constructions. It is reasonable, then, to reject the idea that the Navajo ATB effects arise from some constraint on coindexing involving arguments alone at D-Structure. The ATB effects are due to the status of the constructions in question as adjunction constructions at some level.

Recall, however, that the evidence examined in Chapter 3 regarding the structural position of overt nominals in Navajo indicated that they are not base-generated adjuncts. This conclusion was also consistent with the fact that the pronominal affixes which may "act as" arguments are sub-parts of some other word in Navajo as they are in the other "pronominal argument languages".

If these considerations are correct, then as in Chapter 3, we must find a way to express the fact that Navajo overt nominals are in argument positions at D-Structure but have the status of adjoined elements at some other level of in some other sense.

A further piece of evidence from Navajo which may mitigate against the pronominal coindexing proposal comes from sentences like (4.114). In this coordinate construction, we find that in fact the pronominals may refer freely. If there is a constraint which coindexes null pronominals across the board at D-Structure, we would incorrectly predict constrained coreference in these examples.

(4.114) Ashkii at'ééd yí'déésol dóó asdzáán yah'ííyá' dóó deezgo.
 boy girl whistled and woman entered and fell

- a) 'The boy_i whistled at the girl and the woman entered and he_i fell.'
- b) 'The boy whistled at the girl_i and the woman entered and she_i fell.'
- c) 'The boy whistled at the girl and the woman_i entered and she_i fell.'
- d) 'The boy_i whistled at the girl_j and the woman_k entered and s/he_i fell.'
- (Platero 1978:66)

4.7.6.2 LF extraction and Parallel Variables

One possibility is that the Navajo relative clauses undergo movement at LF, adjoining to S in ATB format, as Hak suggests. Then the ATB effects would be due to constraints on the appearance of variables in parallel structures.

In Section 4.2, I suggested that the Logical Form of internally-headed relative clauses could be derived by extracting the head NP at LF. If these constructions are ATB constructions, then we expect that this extraction will show ATB effects, that is, that it is impossible to extract out of one LF "conjunct" without extracting out of the other. Under such an analysis, the Constraint on ATB Interpretation actually results from independent properties of variables. Consider the ATB representation presented in section 4.3, repeated here:

- (4.115)
- | | | |
|------------------|--------------------|-----------|
| pro _i | pro _j | branded |
| man _i | horse _j | roped-rel |

In Section 4.3, we explained the two different readings which this representation yields in terms of identification of an NP in the matrix

with one in the subordinate clause. Under an extraction account, we could say that the ATB representation was derived by LF movement from either (4.116 a) or (b).

(4.116) a. pro [man horse roped-rel] branded

b. [man horse roped-rel] pro branded

If we extract the object at LF, deriving the ATB representation from sentence a, then we establish a standard ATB variable configuration, and the object of the relative clause is thus required to be a variable also, so that extraction will be across-the-board.

(4.117) pro t_j branded
 [man t_j roped-rel]_j horse_j

Likewise, if the subject is extracted at Logical form, a variable is left in the matrix subject position, and quite general ATB extraction conditions force the relative clause subject to be a variable as well, as shown in (4.118).

(4.118) t_i pro branded
 [t_i horse roped-rel]_i man_i

While the LF extraction account is plausible and has the advantage of being consistent with Haik's account of English parasitic gaps as well as with our assumption that Navajo overt nominals are in argument positions a D-Structure, it presents two problems. First, the underlying representation needed violates the NP-PRO constraint. While

we might circumvent this problem by saying that the NP-PRO constraint does not apply at D-Structure, as it is a control rule, it ought to apply at least before LF. In order to maintain the above account, we would have to resort to some stipulation to exempt relative clauses from the NP-PRO constraint.

Second, notice that in order to get the correct readings, some cross-the-board coindexing of null pronominals is necessary in addition to the constraints on variables. This leads us to suspect that the constraint on variables may not be the correct explanation for the Navajo ATB effects.

Furthermore, extending Haik's account to Navajo implies that the source of the ATB effects is the internally-headed relative clause, because it is the extraction of the relative head which must obey the ATB restrictions. However, there are Navajo constructions which seem to show the ATB effect but do not involve relative clauses:

- (4.119) Kóhoot 'ééd áá' shínaái Naakai Bíkéy ángóó naay áh áa
 last year my-brother Mexico-to went-nom
 yee nihií hólne káanaa'
 about-it us tell(opt.) would-that

'I wish my brother would tell us about his going to Mexico last year.'

In this sentence, the trip taken to Mexico is clearly the event being modified by the adverb kóhoot 'ééd áá' (last year). Therefore, shínaái ('my brother') is located within the embedded clause:

- (4.120) Kóhoot 'ééd áá' shínaái Naakai Bíkéy ángóó naay áh áa
 last year my-brother Mexico-to went-nom
 'my brother's going to Mexico last year'
 (or 'the fact that my brother went to Mexico last year')

Yet shinaaí must be construed as the subject of this sentence, or at least, be construed as coreferent with the subject, so that the apparent violation of condition C which was encountered in the relative clause case is found here too. That is, the is actually parsed and interpreted as:

(4.121) 'I wish he_i would tell us about my brother_i's going to Mexico last year.'

This suggests that the ATB effect is not related to the fact that relative clauses are internally headed.

4.7.6.3 Adjunction, Embedding and Generalized Transformations

It has become apparent as we have proceeded that the ATB effects are related to the status of a particular construction as an adjunction construction. In the previous two sections, we have found reason to reject an analysis in which ATB effects arise from 1) a coindexing constraint on D-Structure arguments and 2) LF movement of the relative clause itself. In this section, I will claim that the ATB effects are related to the principles by which the thematic properties of adjunction constructions are assigned a unified representation.

Consider the mechanisms which exist in current theory for unifying separate sets of thematic properties. In the earliest Generative Grammars, such as Chomsky(1955), the recursive property of the Grammar was thought to arise from the existence of Generalized Embedding Transformations, which effected the insertion of complex P-markers into other complex P-markers. Fillmore(1963), in an attempt to restrict the

possible ways in which the output of a generalized transformation may be used as input to other transformations, defines embedding transformations as in (4.122), and contrasts them with conjoining transformations.²⁵

(4.122) An embedding transformation identifies a set of pre-sentences and expands a symbol in a terminal string as some mutation of any of the identified pre-sentences. An embedding transformation therefore has the form:

Given P
 A -----> P' in context W__Y

Where A alone is a constant and where the relation between P and P' can be stated in the form of a simple transformation.

W A Y is a terminal string, and P is a pre-sentence.

(4.123) Conjoining transformations are transformations which identify two pre-sentences, P and P', and convert these into a new pre-sentence P". A conjoining transformation can be stated in the form

P
) ---> P"
 P'

Where the relation between P & P' and P" can be stated in the form of a simple transformation, with the added restriction that neither can be entirely deleted.

(Fillmore 1963:212)

This distinction is crucial in considering the source of ATB effects, because while the use of generalized transformations to capture recursion was abandoned shortly after Fillmore made this distinction,

25. Pre-sentences are representations which are ready to undergo a final group of obligatory and stylistic rules which yield, as the final output of the Grammar, phonetic descriptions.

their use as a means of putting together phrase markers which are not otherwise related in underlying structure has never been discredited. Clearly embedding transformations are redundant with lexical subcategorization frames; the sub-phrase marker for any argument will be licensed at D-structure in virtue of its status as a selected argument, and no transformation is necessary to embed it. However, as was pointed out in Chapter 1, some surface phrase markers contain sub-phrase markers which seem to be independent at D-Structure. If it is the case that some elements are inserted after D-Structure, then we may term the operation by which two phrase markers are combined a 'generalized transformation.' In current theory, any transformational operation is a subcase of 'affect alpha', and as such may apply freely as long as no independent principles of the Grammar are violated. An investigation of the properties of generalized transformations in current theory, therefore, amounts to a search for the appropriate general principles in the cases under scrutiny.

Let us consider the formal properties of the constructions which show ATB effects cross-linguistically. I am maintaining that it is adjunction constructions which show these effects. In Chapter 1 I pointed out that adjunction constructions have the peculiar property of including a pair of categories for which neither a domination nor a precedence relation holds. We might also describe the adjunction configuration as one in which there is a category A, the adjoined category, which both is and is not included in the adjoined-to category, B. This is particularly clear in the case of an LF adjunction, where at S-structure the category A actually is included in

the category B. Because of constraints on possible rules in GB theory, in particular, because of the Projection Principle which requires that LF movement from an argument position leave a trace, the configuration set up for LF adjunction is one which expresses the ambiguous inclusion property outlined above.

This sort of configuration is very different from a subordination construction, where the embedded constituent is dominated by a matrix category. In subordination, a matrix head selects for features of the subordinate clause, and the subordinate clause fills a position in the theta grid of the head.

ATB effects seem to arise when there is more involved than simple theta-discharge in determining how the theta properties of two categories are to be related. In this sense, we might think of the set of principles which give rise to ATB effects as something very like a generalized transformation.

Let us see how this might work for the Navajo cases.

I am taking the position that adjunction constructions are phrase markers with the particular properties outlined above, namely that the adjoined category simultaneously is and is not included in the adjoined-to category. This view leads us to an explanation of the fact that Navajo nominals behave like adjuncts insofar as they show ATB effects, although they are in argument positions. At the end of Chapter 3, I concluded that Navajo nominals are in argument positions, but that they form a CHAIN with elements of the morphological

representation. The representation which I gave (3.50) can be simplified to (4.124) (note: the subject clitic is a zero-form in the third person, and this zero was used as the representation for the subject in Chapter 3):

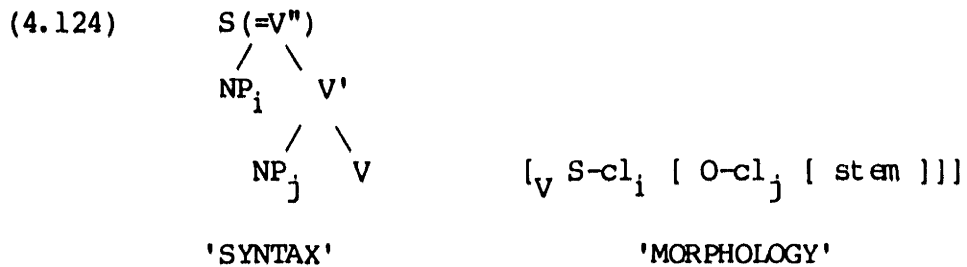

Now, if the adjunction configuration is just that where one category simultaneously is and is not included in another, this configuration would seem to be satisfied in the representation above. While the nominal is not included in the maximal projection of the morphological verb, in virtue of the chain formed between the clitic and the overt nominal, the nominal is not excluded from the maximal projection of the morphological verb. This becomes clearer when we consider the fact that the theta role is assigned to the CHAIN, and hence is assigned to a category both internal to and external to the maximal morphological projection. Thus, the formation of the CHAIN establishes a configuration in which there is more to say about the theta relations between two categories than there would be in a simple embedding. In this way, the Navajo configuration, in which a CHAIN is formed between an argument and an affix, fits the description of an adjunction construction. As it is a configuration of adjunction in this sense, we may expect generalized transformations to be relevant to its formation.

REFERENCES

- Abney, Steven(1986) "Functional Elements and Licensing," presented at GLOW conference, Barcelona.
- (1985) "Functor Theory and Licensing: Toward an Elimination of the Base Component", ms. MIT, Cambridge, MA.
- Akmajian, Adrian and Anderson, Stephen(1970) "On the Use of Fourth Person in Navajo, or Navajo Made Harder", IJAL 36.1
- Anderson, Mona(1984) "Prenominal Genitive NPs," The Linguistic Review 3:1.
- Aoun, Youssef and D. Lightfoot(1984) "Government and Contraction," Linguistic Inquiry 15:3.
- Baker, Mark(1986) "Morphology and Syntax: An Interlocking Dependency" presented at Groningen Workshop on Morphology.
- (1985) Incorporation. A Theory of Grammatical Function Changing, unpublished MIT PhD dissertation.
- (1983) "'Assume GF' and the Order of Morphemes" MIT working Papers in Linguistics, vol.5.
- Barss, Andrew(forthcoming) Chains and Anaphoric Dependencies, Doctoral Dissertation, MIT, Cambridge, MA.
- Barss, Andrew, Kenneth Hale, Ellavina Perkins, Margaret Speas(1985) "Aspects of Logical Form in Navajo" in Cook&Rice, eds, Studies in Athabaskan Syntax.
- Belletti, A. and L. Rizzi (1985) "Psych-verbs and Theta-Theory " talk presented at MIT-Lexicon Seminar.
- Bergvall, Victoria(1986) Doctoral Dissertation, Harvard University Cambridge, MA.
- Borer, Hagit (1984) Parametric Syntax, Foris, Dordrecht.
- Brane, Michael(1981) "The General Theory of Binding and Fusion", Linguistic Analysis 7.3.
- (1982) "The Head-Selector Theory of Lexical Specifications and the Nonexistence of Coarse Categories", Linguistic Analysis 10.4.

- Bresnan, Joan(1972) Theory of Complementation in English Syntax,
 Doctoral Dissertation, MIT, Cambridge, MA.
- Brody, M. (1984) "On the Contextual Definitions and the Role of
 Chains," Linguistic Inquiry 15.3, 355-380.
- Burzio, L. (1981) Intransitive Verbs and Italian Auxiliaries, PhD
 Dissertation, MIT.
- Chomsky, Noam(1986 a) Knowledge of Language: Its Nature, Origin and Use,
 Praeger, New York.
- (1986b) Barriers MIT press, Cambridge, MA.
- (1981) Lectures on Government and Binding, Foris publications,
 Dordrecht.
- (1970) "Remarks on Nominalization", in Readings in English
 Transformational Grammar, Jacobs and Rosenbaum, eds., Ginn and
 Co., Waltham, MA.
- (1965) Aspects of the Theory of Syntax, MIT Press, Cambridge, MA.
- (1955) The Logical Structure of Linguistic Theory, published
 (1979) by University of Chicago Press.
- Chung, Sandra(1983) "The ECP and Government in Chamorro", Natural
 Language and Linguistic Theory, 1.2.
- Culicover, Peter and K. Wexler(1973) "Three Further Applications of the
 Freezing Principle in English," Social Sciences Working Papers
 #48, The University of California, Irvine, CA.
- Davidson, D. (1966) "The Logical Form of Action Sentences," in Davidson
 (1980) Essays on Actions and Events. Oxford: Clarendon Press.
- Davis, Philip and Ross Saunders(1984) "An Expression of Coreference in
 Bella Coola", in Cook and Gerds, eds., Syntax and Semantics 16:
 The Syntax of Native American Languages, Academic Press.
- diSchiullo, Ann-Marie(1980) "N and X-bar Theory," in J.T. Jensen, ed.,
Proceedings of the 10th Annual Meeting of NELS, Cahiers
 Linguistique d'Ottawa 9, Dept. of Linguistics, The University of
 Ottawa.
- Emonds, Joseph(1985) A Unified Theory of Syntactic Categories, Foris,
 Dordrecht.
- Fabb, Nigel(1984) Syntactic Affixation, Doctoral Dissertation, MIT,
 Cambridge, MA.

- Farmer, Ann(1984) Modularity in Syntax, MIT Press, Cambridge, MA.
- (1980) On the Interaction of Morphology and Syntax, Doctoral Dissertation, MIT, Cambridge, MA.
- , Ken Hale and Natsuko Tsujimura(1986) "A Note on Weak Crossover in Japanese," NLLT 4.1.
- Fillmore, Charles(1968) "The Case for Case," in E. Bach and R. Harms eds., Universals in Linguistic Theory, Holt, Rinehart, Winston, New York.
- -- (1963) "The Position of Embedding Transformations in a Grammar", Word v. 19.
- Flynn, Michael(1983) "A Categorical Theory of Structure Building", in Gazdar, Klein and Pullum, eds., Order, Concord and Constituency Foris, Dordrecht.
- Fodor, Jerry (1983) The Modularity of Mind MIT Press Cambridge, MA.
- Fukui Naoki(1984) "Studies on Japanese Anaphora I" ms. MIT Cambridge, MA.
- - - (1986) A Theory of Category Projection and Its Applications Doctoral Dissertation MIT Cambridge MA.
- Fukui, Naoki and Margaret Speas(1986) "Specifiers and Projection" MIT Working Papers, vol. 8
- George, Leland(1980) Analogical Generalizations in Natural Language Syntax Doctoral Dissertation MIT Cambridge MA
- Goodall, Grant(1984) Parallel Structures in Syntax Doctoral Dissertation, UCSD.
- Gueron J and R May (1984) "Extrapolation and Logical Form " Linguistic Inquiry 15.1 1-32.
- Häk, Isabelle(1985) The Syntax of Operators, Doctoral Dissertation MIT
- Hale, Kenneth (1985) "On Nonconfigurational Structures" ms MIT
- (1983) "Warliri and the Grammar of Non-Configurational Languages", Natural Language and Linguistic Theory Vol 1 1
- (1980) "The Position of Warliri in a Typology of the Base," Indiana University Linguistics Club.
- (1982) "Some Preliminary Remarks on Configurationality" NELS 12, 86-96

- (1975) "Counterexamples and Explanations in Navajo Linguistics Syntax" Dine Bizaad Nanil iih 2 1
- Hale, Jeanne and Platero (1978) "Three Cases of Overgeneration" in Akmajian Culicover and Wasow Formal Syntax Academic Press
- Hale, K. and J. Keyser (1985) "Some Transitivity Alternations in English " unpublished MIT manuscript.
- Hale and Platero (1974) "Aspects of Navajo Anaphora: Relativization and Pronominalization" Dine Bizaad Nanil iih 1 1
- Hargus, Sharon (1986) "Phonological Evidence for Prefixation in Navajo Verbal Morphology" WCCFL Seattle WA
- Harris Zelig (1951) Methods in Structural Linguistics University of Chicago Press.
- Hasegawa Nobuko (1981) A Lexical Interpretive Theory with Emphasis on the Role of Subject, Doctoral Dissertation University of Washington Seattle WA
- - (1980). "The VP Constituent in Japanese" Linguistic Analysis 6 2
- Higginbotham, James (1986) "Elucidations of Meaning" ms. MIT.
- --- (1985) "On Semantics" Linguistic Inquiry 16 4
- Hinds, John (1973) "On the Status of the VP node in Japanese" Language Research 9.
- Hoijer, Harry (1971) "Athapaskan Morphology" UCLA Publications in Linguistics 65, 113-147.
- Horvath Julia (1986) Focus in the Theory of Grammar and the Syntax of Hungarian Foris, Dordrecht.
- (1981) Aspects of Hungarian Syntax and the Theory of Grammar Doctoral Dissertation, UCLA
- Huang C. T. J. (1984) "On the Distribution and Reference of Empty Pronouns", L. I. 15.4.
- --- (1982) Logical Relations in Chinese and the Theory of Grammar, unpublished MIT PhD dissertation.
- Huybregts, Riny and Henk van Riemsdijk (1984) "Parasitic Gaps and ATB" NELS
- Jackendoff Ray (1977) X Syntax A Study of Phrase Structure MIT Press Cambridge, MA.

- Jaeggli, Osvaldo(1980) "Remarks on to-contraction " Linguistic Inquiry 11:1.
- Jelinek Eloise(1984) "Case and Configurationality" Natural Language and Linguistic Theory 2.1.
- Jelinek Eloise and R. Demers (1985) "Constraints on Arguments in Lummi", Proceedings of the 20th International Conference on Salish and Neighboring Languages. Vancouver B c.
- Jelinek, Eloise and Merton Sandoval(1985) "Ergativity in Apachean: the bi-Construction", in Cook and Rice, eds, Studies in Athabaskan Syntax.
- Johnson, Kyle(1985) A Case for Movement, Doctoral Dissertation, MIT, Cambridge, MA.
- Kari James(1979) Athabaskan Verb Theme Categories; Ahtna, Alaska Native Language Center Research Papers #2 Fairbanks, AK
- (1976) Navajo Verbal Prefix Phonology, Ph.D Dissertation, University of New Mexico, Albuquerque, NM.
- Kaufman, Ellen(Schauber)(1974) "Navajo Spatial Enclitics. A Case for Unbounded Rightward Movement" LI 5.4.
- --- (1975) "Extraposition of Relative Clauses in Navajo' Dine Bi zaa'd Nanil'iih 2.2.
- Kayne, Richard(1983) "Chains Categories External to S and French Complex Inversion," Natural Language and Linguistic Theory 1 1
- (1986) "Participles, Agreement, Auxiliaries, se/si and PRO" ms MIT, Cambridge, MA.
- Kenesi, I.(1984) "On What Really Figures in a Nonconfigurational Language " Groninger Arbeiten zur Germanistischen Linguistik 24 28-54.
- E. Kiss, K.(1985) "Is the VP Universal?" ms., MIT and University of Budapest.
- (1981) "Structural Relations in Hungarian, a "Free" Word Order Language, L.I. 12.
- Koopman, Hilda(1984) The Syntax of Verbs, Foris. Dordrecht.
- Koopman, Hilda and D. Sportiche(1986) "ECP and Subjects," talk presented at MIT, Cambridge, MA.
- (1985) "O-Theory and Extraction," presented at GLOW meeting, Brussels.

- (1982) "Variables and the Bijection Principle," The Linguistic Review 2.2, 139-160.
- Krauss, Michael (1969) "On the Classifiers in the Athapaskan, Eyak and Tlingit Verb", Indiana Univ. Publications in Anthr. and Ling., Memoir 24 of IJAL Suppl to 35(4):53-83.
- Kuno, Susumu (1973) The Structure of the Japanese Language, MIT Press Cambridge, MA.
- Kuroda, S.-Y. (1985) "Whether You Agree or Not. Rough Ideas about the Comparative Grammar of English and Japanese" ms. University of California, San Diego.
- (1980) "Bunkoozoo-no hikaku," in T. Kunihiro, ed., Nitueigo Hikaku-Kooza 2: Bunpoo, Taiyukan, Tokyo.
- Larson, Richard (1985) "Bare NP Adverbs," Linguistic Inquiry 16:4.
- Lasnik, Howard and Joseph Kupin, (1977) "A Restrictive Theory of Transformational Grammar", Theoretical Linguistics 43.
- Levin, Beth (1983) On the Nature of Ergativity, Doctoral Dissertation, MIT, Cambridge, MA.
- Lumsden, John (1984) "A Baroque Theory of Subjects" ms. MIT, Cambridge, MA.
- Maracz, Lazlo (1986) "On Transitivity in Nonconfigurational Languages", in F. Beukma and A. Hulk, eds., Linguistics in the Netherlands 1986, Foris, Dordrecht.
- (1985) "Some Notes on Weak Crossover in Hungarian", in Bennis and Beukma, eds., Linguistics in the Netherlands 1985, Foris, Dordrecht.
- Marantz, Alec (1984) On the Nature of Grammatical Relations, MIT Press, Cambridge, MA.
- Masunaga, K. (1982) "Bridging" In S. Hatori and K. Inoue, eds, Proceedings of the XIIth International Congress of Linguists, Tokyo.
- May, Robert (1985) Logical Form, MIT Press.
- McCawley, James (1968) "Concerning the Base Component of a Transformational Grammar", in Foundations of Language 4.
- (1970) "English as a VSO Language" Language 46.
- Mohanan, K.P. (1983) "Lexical and Configurational Structures" The Linguistic Review, 3.2 1983-84.

- (1982), "Grammatical Relations and Clause Structure in Malayalam", in Bresnan, ed., The Mental Representation of Grammatical Relations.
- Muysken, Pieter (1982) "Parameterizing the Notion 'Head'", Journal of Linguistic Research 2:3.
- (1981) "Quechua Causatives and Logical Form: A Case Study in Markedness" in Proceedings of 1979 GLOW Conference, Belletti, Brandi and Rizzi, eds.
- Nash, David (1980) Topics in Warlpiri Grammar, Doctoral Dissertation, MIT, Cambridge, MA.
- Oehrle, Richard (1981) Appendix 1 in Steele et. al. The Encyclopedia of AUX, MIT Press, Cambridge, MA.
- Ostler, Nick (1979) Case-Linking: A Theory of Case and Verbal Diathesis Applied to Classical Sanskrit, Doctoral Dissertation, MIT, Cambridge, MA.
- Perkins, Ellavina Tsosie (1978) The Role of Word Order and Scope in the Interpretation of Navajo Sentences, University of Arizona Ph.D Dissertation, Tucson, AZ.
- (1975) "Extraposition of Relative Clauses in Navajo" Dine Bizaad Nanil'iih 2.2.
- Perlmutter, D. (1978) "Impersonal Passive and the Unaccusative Hypothesis," in Proceedings of Fourth Annual Meeting of the Berkely Linguistics Society, University of Berkely.
- Pesetsky, David (1983) "Morphology and Logical Form", ms. University of Southern California and U. Mass Amherst.
- (1982) Paths and Categories, Doctoral Dissertation, MIT, Cambridge, MA.
- Picallo, C. (1984) Opaque Domains, unpublished CUNY PhD dissertation.
- Platero, Paul (1978) Missing Noun Phrases in Navajo Ph.D. Dissertation, MIT.
- (1974) "The Navajo Relative Clause" IJAL 40.3.
- Pullum, Geoff (1985) "Assuming Some Version of X-Bar Theory," presented at Chicago Linguistic Society 21.
- Reinhart, Tanya (1976) The Syntactic Domain of Anaphora, Doctoral Dissertation, MIT, Cambridge, MA.

- Reuland, Eric(1983) "Governing -ing," Linguistic Inquiry 14.
- Rice, Keren(1985) "On the Placement of Inflection", LF 16:155-61.
- Rizzi, L. (1982a) Issues in Italian Syntax, Foris Publications.
- Rizzi, L. (1982b) "On Chain Formation," unpublished manuscript.
- Roeper, Thomas(1983) "Implicit Thematic roles in the Lexicon and Syntax" ms., University of Massachusetts, Amherst, MA.
- Ross, John(1967) Constraints on Variables in Syntax, Doctoral Dissertation, MIT, Cambridge, MA.
- Rothstein, Susan(1983) The Syntactic Forms of Predication, Doctoral Dissertation, MIT, Cambridge, MA.
- Saito, Mamoru(1985) Some Asymmetries in Japanese and their Theoretical Implications, Doctoral Dissertation, MIT, Cambridge, MA.
- (1982) "Comments on the Papers on Generative Syntax" in Proceedings on Arizona Japanese Conference.
- and Hajime Hoji (1983) "Weak Crossover and Move-alpha in Japanese" NLLT 1.2.
- Sapir, Edward(1921) Language, Harcourt, Brace and World, New York.
- Saxon, Leslie(1986) Dogrib Pronouns, Doctoral Dissertation, University of California, San Diego.
- Schauber, (Kaufman) Ellen(1979) The Syntax and Semantics of Questions in Navajo Garland Publishing, New York.
- Sells, Peter(1984) Syntax and Semantics of Resumptive Pronouns, Doctoral Dissertation, U.Mass, Amherst, MA.
- Simpson, Jane(1983) Aspects of Warlpiri Morphology and Syntax, Doctoral Dissertation, MIT, Cambridge, MA.
- Speas, Margaret (1986) "On the Position of Navajo in the Configurationality Debate", Groningen Roundtable on Configurationality.
- (1984) "Navajo Prefixes and Word Structure Typology" MIT Working Papers, vol.7.
- Sproat, Richard(1985) "Welsh Syntax and VSO Structure", Natural Language and Linguistic Theory, 3.2
- Stowell, Tim(1981) Origins of Phrase Structure, Doctoral Dissertation, MIT, Cambridge, MA.

- (1982) "Subjects Across Categories", The Linguistic Review 2.
- Stuurman, Frits (1985) Phrase Structure in Generative Grammar, Foris, Dordrecht.
- Szabolcsi, Anna (1984) "The Possessor that Ran Away from Home", The Linguistic Review 3.1.
- Taraldsen, T. (1983) Parametric Variation in Phrase Structure: A Case Study, University of Tromsø.
- Travis, Lisa (1984) Parameters and Effects of Word Order Variation, Doctoral Dissertation, MIT, Cambridge, MA.
- Walli, B. (1983) "An Investigation of a Pro-Drop Account for Navajo Missing Noun Phrases" ms. MIT.
- Whitman, John (1984) "Configurationality Parameters" ms. Harvard University, Cambridge, MA.
- Williams, Edwin (1985) "PRO and Subject of NP," Natural Language and Linguistic Theory 3:3.
- (1981a.), "Argument Structure and Morphology," The Linguistic Review, 1.
- (1981b) "On the Notions 'Lexically Related' and 'Head of a Word'," L. I. 12, 245-274.
- (1980) "Predication," Linguistic Inquiry 11.1, 203-238.
- (1978) "Across the Board Rule Application", L. I. 9.1.
- Willie, MaryAnn (1985) "Why There is Nothing Missing in Navajo Relative Clauses", in Cook and Rice, eds, Studies in Athabaskan Syntax.
- Wright, Martha (1983) "The CV Skeleton and Verb-Prefix Phonology in Navajo", NELS 14, Amherst, MA.
- Yamada, Hiroshi (1983) "Notes on the 'DET=PRO' Analysis of English Picture NP Reflexives," in K. Inoue et. al., eds., Issues in Syntax and Semantics: Festschrift for Masatake Muraki, Sansyusya, Tokyo.
- Young, Robert and W. Morgan (1980) The Navajo Language University of New Mexico Press, Albuquerque, NM.
- Zubizarreta, M.-L. (1982) On the Relationship of the Lexicon to Syntax, unpublished MIT PhD dissertation.
- Zubizarreta, M.-L. and J.R. Vergnaud (1982) "On Virtual Categories", MIT Working Papers in Linguistics, vol 4.