

MASSACHUSETTS INSTITUTE OF TECHNOLOGY
HAYSTACK OBSERVATORY
WESTFORD, MASSACHUSETTS 01886

December 3, 2018

Telephone: 617-715-5533

Fax: 617-715-0590

To: EDGES Group

From: Alan E.E. Rogers

Subject: Update on aspects of the EDGES-3 antenna and electronics design

The original concept of the EDGES-3 antenna and electronics is described in memo #289. In this memo I plan to report changes in the proposed design as a result of the further study.

1] Calibration switching

The block diagram in Figure 3 of memo #289 is replaced with an improved switch configuration shown in Figure 1.

This switch configuration reduces the number of switch contacts between the LNA and the antenna from 4 to 3. A further reduction is possible if the 8-T input switch could provide the 3-position switching but this possibility awaits further study of the switch contact resistance change over the switch lifetime.

2] Boxblade antenna refinement

The antenna design proposed in memo #289 has rectangular boxes with dimension 73.4×95.3×12 cm. A better S11 over a frequency range of 60 to 160 MHz can be achieved by modifying the shape to that shown in Figure 2. The dimension of 73.4 cm in the middle of the box is decreased by 6.5 cm to 66.9 cm at the edges of the box for a gap between boxes that is 13 cm larger at the edges than at the middle. Figure 3. and 4 show the S11 from FEKO for the antenna over an infinite ground plane without and with tubes to carry the power fiber. Figure 5 shows the measured S11 of the midband blade antenna for comparison. The best fit delay for the boxblade is 12 ns compared with 20 ns for the midband blade with balun. The pipes have no appreciable effect on the beam chromaticity.

Box length in middle	73.4
Box length at edge	66.9
Box height	12.0
Box width	95.3
Height of box bottom above ground plane	72.0
Radius of antenna connection	2.54
Radius of pipes	1.27
Best gap at center without pipes	2×3.2
Best gap at center with pipes	2×3.0
Table 1. Dimensions of boxblade antenna used in FEKO simulations in cm.	

A test of the effect on reduced delay was made by simulation of the rms residual to a 5-term linlog polynomial for a 30 ps error in antenna S11 measurement. The results for the boxblade with or without pipes and the midband antenna were 36 and 94 mK respectively for a frequency range of 60-160 MHz at GHA = 12 hours.

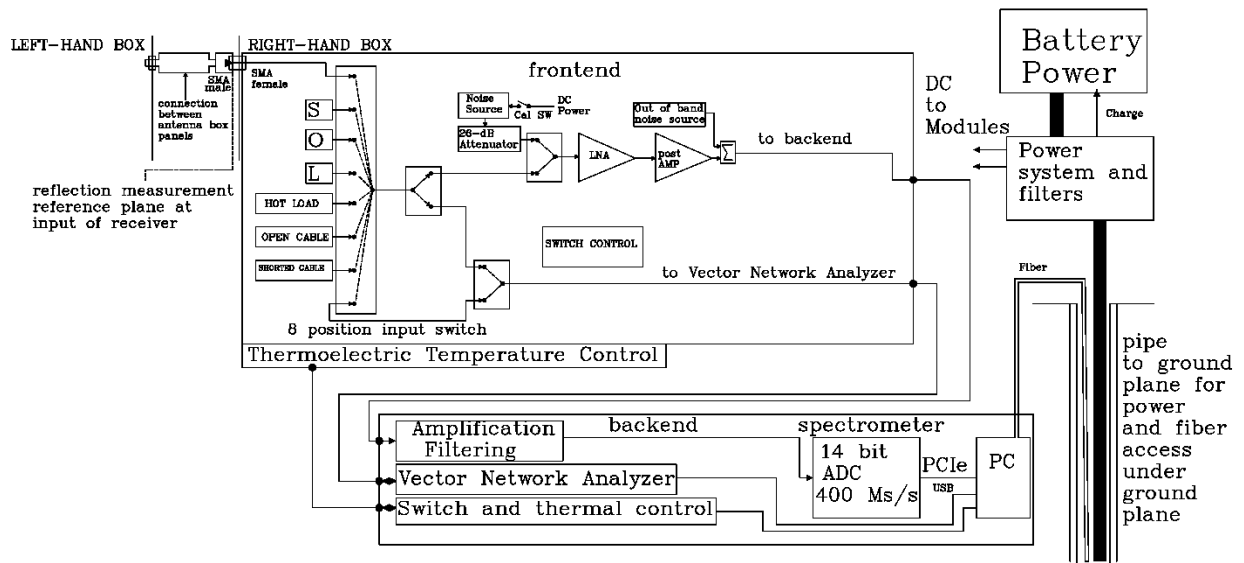

Figure 1.

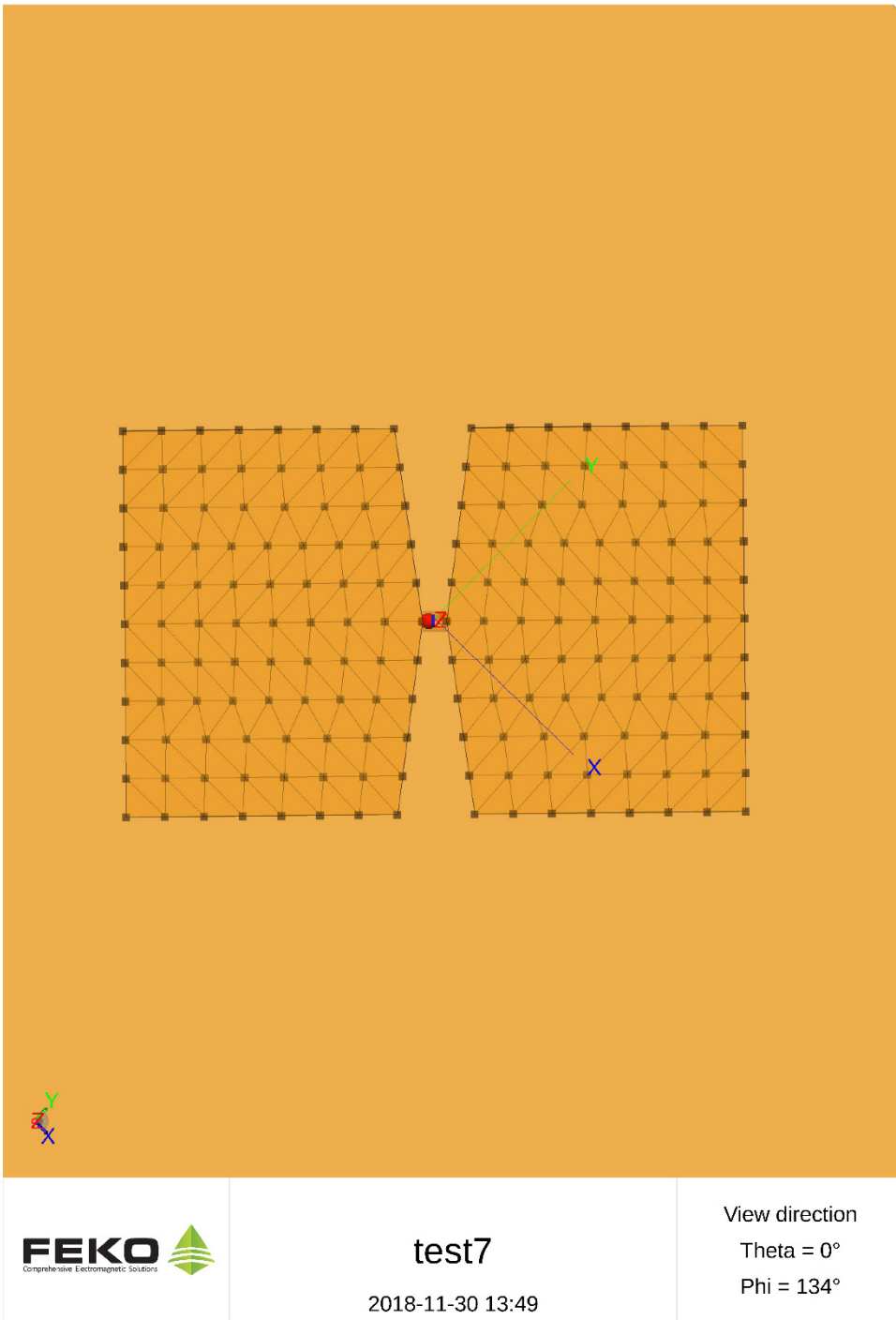

Figure 2. Shape of boxblade for best S11 60 to 160 MHz.

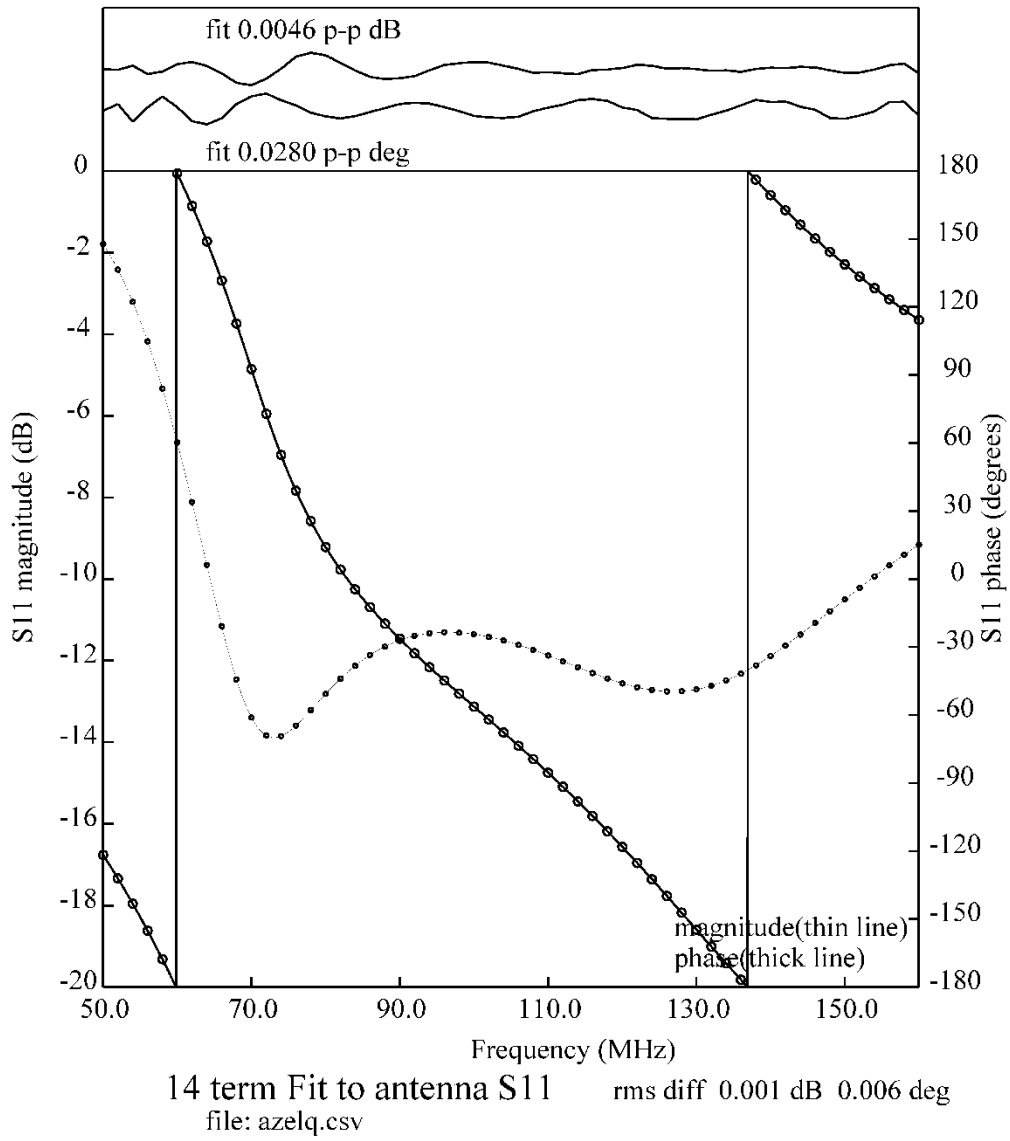

Figure 3. S11 from FEKO for boxblade over PEC without tubes.

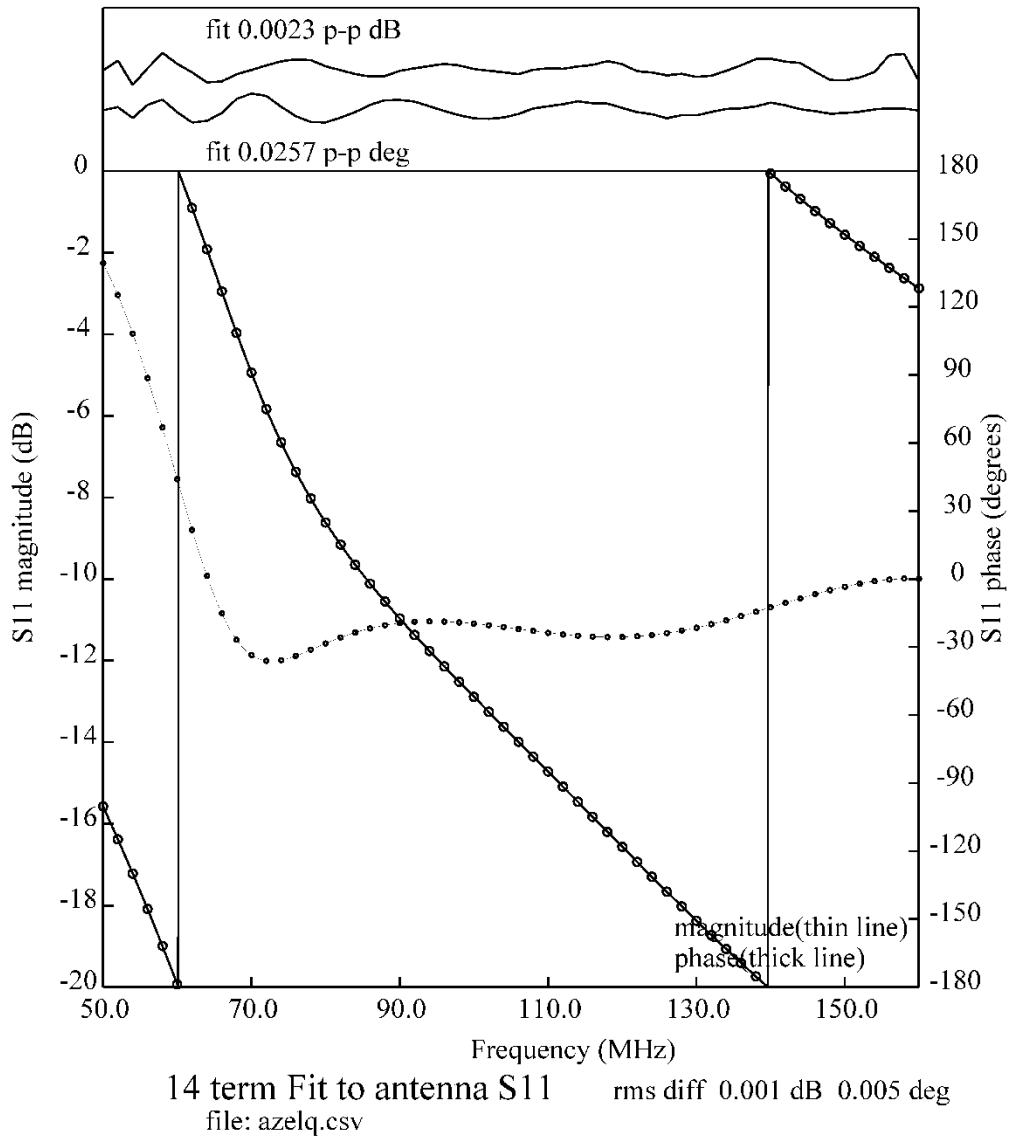
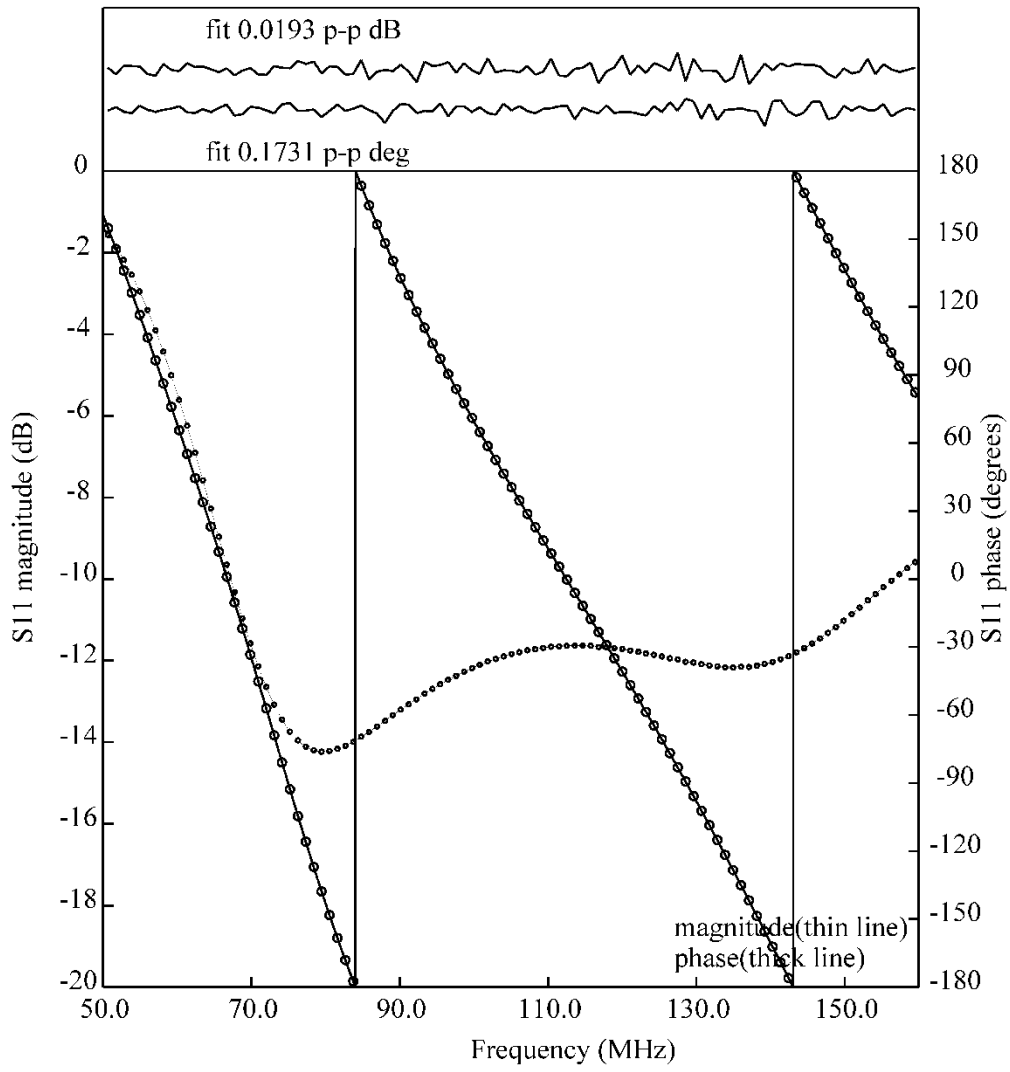

Figure 4. S11 with tubes for power.



14 term Fit to antenna S11 rms diff 0.004 dB 0.026 deg
 file: /home/aer/data/px14/mro/datarcv1/mid-rcv1-20180527/2018_147_16_52_34.c

Figure 5. Measured S11 for midband blade.