

DETERMINATION
OF
MOISTURE LEVEL IN POLYMERS

BY

Byung Hoon Kim

B.S., University of California, Berkeley, 1978

SUBMITTED IN PARTIAL FULFILLMENT
OF THE REQUIREMENT FOR THE
DEGREE OF

MASTER OF SCIENCE

at the

© MASSACHUSETTS INSTITUTE OF TECHNOLOGY

May 19, 1980

Signature of Author _____

Department of Mechanical Engineering
May 19, 1980

Certified by _____

Thesis Supervisor

Accepted by _____

Chairman, Department Committee on Graduate Students

ARCHIVES
MASSACHUSETTS INSTITUTE
OF TECHNOLOGY

JUL 27 1980

LIBRARIES

DETERMINATION
OF
MOISTURE LEVEL IN POLYMERS
BY

Byung Hoon Kim

Submitted to the Department of Mechanical Engineering on May 19, 1980 in partial fulfillment of the requirements for the Degree of Master of Science in Mechanical Engineering

ABSTRACT

Two new methods of moisture measurement in polymers are presented: d.c. and a.c. methods. The d.c. method measures the amplitude of decaying current when a d.c. field is applied across the bulk of the sample. The d.c. current is sensitive to the moisture level in polymers, which can be monitored to determine the moisture level. The a.c. method can detect minute amounts of moisture by determining the dielectric loss factor at the moisture-sensitive frequency. Using these techniques, the moisture-sensitive frequency of the following polymers has been determined at room temperature: polyamide, poly (amide-imide), polyethylene terephthalate, polycarbonate, polymethylmethacrylate, and thermoplastic polyurethane. Because these techniques are accurate and fast, on-line measurement of the moisture levels in polymers is possible, which can be used as a process control tool.

Thesis Supervisor: Nam P. Suh
Title: Professor of Mechanical Engineering

ACKNOWLEDGEMENTS

The author would like to express his deepest thanks to Professor Nam P. Suh for his support, leadership, and supervision. I owe him a great deal.

The author would also like to thank Bill Westphal for his numerous hours spent in discussing and collecting many dielectric property measurements. Also thanks to Professor Stephen D. Senturia for his useful suggestions.

This research was sponsored by the M.I.T. - Industry Polymer Processing Program. The sponsors of the program are AMP Inc., Eastman Kodak Co., General Motors Corp. Goodyear Tire and Rubber Co., Instrumentation Laboratories Inc., International Telephone & Telegraph Corp., Lord Corp., Rogers Corp., and Xerox Corp. John Diener, at AMP Inc., deserves a special thanks for his critical comments and suggestions which have helped orient this project to useful industrial applications. Besides the technical help, I had a lot to learn from him. Ken Cheng formerly associated with AMP Inc. is a pleasant fellow. Through him I enjoyed industrial academic interactions. Thanks also to other industrial members who helped this project.

The staff and students of the Material Processing Laboratory were helpful at many stages of this project. In particular, Technical Instructors Fred (Andy) Anderson, Ralph Whittemore, Bob Kane, John Ford, and Fred Cote were consulted on many details concerning machining and apparatus construction. My colleagues around the Lab deserve many thanks for their help in this project. They include,

Kwai - Yung Su, Tim Gutowski, Rich Okine, Jane Martini, Whit Halstead, John Border, Ming Tse, Ken Smith, Jim Rinderle, Luu Nguyen, Frank Waldman, Hyo - Chol Sin, Jae Youn, and Hyun - A Park.

Next, I would like to thank three women, Young Ja Suh (Prof. Suh's wife), Young Hee Choi, and Hyae Sung Kim for nice, hot, home cooked meals. I would like to give a very special thanks to Hyae sung Kim for her warmth in helping me when I faced hardship in nontechnical difficulties. I am grateful in getting to know her and her husband, Sun Woong Kim.

A final note of thanks goes to my parents. I appreciate my father's courage to start a new life in a strange land for the sake of his children's education, and my mother's continual prayer for me.

TABLE OF CONTENTS

<u>CHAPTER</u>		<u>Page Number</u>
	Title Page	1
	Abstract	2
	Acknowledgements	3
	Table of Contents	5
	List of Figures	7
	List of Tables	9
	Nomenclature	10
I.	Introduction	12
II.	Literature Review	16
	II-A Nylon 6/6	16
	II-B Dielectric Terminology	19
	II-c Nature of Water Absorption	23
	II-D Moisture - Sensitive Relaxation	25
III.	III-A: D.C. Experiment	28
	III-A-1: Experimental Procedures	28
	III-A-2: Sample Preparation	40
	III-A-3: Results	44
	III-B: A.C. Experiment	49
	III-B-1: Experimental Procedures	49
	III-B-2: Sample Preparation	51
	III-B-3: Results	53
	III-C: Temperature Run	70
	III-C-1: Experimental Procedures	70
	III-C-2: Sample Preparation	72
	III-C-3: Results	72

<u>CHAPTER</u>		<u>Page Number</u>
	III-D: Comparative Measurement	74
	III-D-1: Experimental Procedures	74
	III-D-2: Sample Preparation	76
	III-D-3: Results	76
	III-E: Conduction Mechanism	78
	III-E-1: Experimental Procedures	78
	III-E-2: Sample Preparation	80
	III-E-3: Results	80
IV.	Discussion	84
V.	Conclusions	89
	References	91
	Appendices	
	A1 Hydrolysis Mechanism of Polyamide	94
	A2 Dielectric data of Nylon 6/6	96

LIST OF FIGURES

<u>Figure</u>	<u>Page Number</u>
1. Ideal capacitor in series with a sinusoidal voltage source	21
2. Vector diagram of the current through a dielectric	22
3. Simple model of a polymer sample	29
4. Circuit diagram for a polymer sample subjected to a D.C. step voltage	30
5. Expected current-time response of a polymer sample	33
6. Expected current-time response of a polymer with increasing moisture level	34
7. Circuit diagram of the D.C. apparatus	35
8. Lay out of the D.C. experiment	36
9. General view of a sample holder box	37
10. Diagram of the sample holder	38
11. Circuit diagram of the switch	39
12. Step response of nylon 6/6 (Vydyne 21) with three different moisture levels at 23°C a) 0.7%, b) 0.6%, c) 0.5%	45
13. Step response of nylon 6/6 (Vydyne 21x) with 3.45% moisture, at 23°C	46
14. Step response of nylon 6/6 (Vydyne 21x) with 0.26% moisture, at 23°C	47
15. Current (t = 20 sec.) VS. applied Voltage for polyuretane at 23°C	48
16. Detailed view of the disassembled sample holder for granules	50
17. Loss factor vs. frequency for nylon 6/6 (Vydyne 21) at 23°C	59

<u>Figure</u>	<u>Page Number</u>
18. Loss factor vs. frequency for nylon 6/6 (Vydyne 21x) at 23°C	60
19. Loss factor vs. frequency for nylon 6/6 (J 120 FR) at 23°C	61
20. Loss reading vs. moisture content at 23°C	64
21. Loss Tangent vs. Frequency for Polycarbonate at 23°C	65
22. Loss Tangent vs. Frequency for PMMA at 23°C	66
23. Loss tangent vs. frequency for polyurethane at 23°C	67
24. Loss factor vs. frequency for polyethylene terephthalate at 23°C	68
25. Loss factor vs. frequency for poly (amide-imide) at 23°C	69
26. Schematic of the temperature experiment; 1) mixer, 2) temperaturesensor, 3) thermocouple (T.C. #1), 4) termocouple (T.C. #2)	71
27. Loss reading vs. temperature for nylon 6/6 (Vydyne 21x) at 20K Hz.	73
28. Impedance comparator (G.R. type 1605-A) with the adjustable standard box and the sample holder	75
29. Circuit diagram of the conduction experiment	79
30. S.E.M photograph of the brown dots (X 1000)	82
31. Photograph of X-ray Energy Spectrum of a brown dot	83

LIST OF TABLES

<u>Table</u>		<u>Page Number</u>
1.	Sample Conditions	41
2.	Moisture data by the Meeco Analyzer	42
3.	Conditioning of samples and their moisture levels	43
4.	Conditions of samples and their moisture levels	58
5.	Readings of ΔD & ΔC after the sample holder has been shaken	62
6.	Compensated ΔD values	63

NOMENCLATURE

I_C	charging current
Q	charge
C_0	capacitance of ideal capacitor
V	sinusoidal voltage source
ω	angular frequency
I	total current
I_L	loss current
j	$\sqrt{-1}$, denotes imaginary number
ϵ^*	complex permittivity
ϵ'	dielectric constant
ϵ''	dielectric constant
κ^*	complex relative
κ'	relative dielectric constant
κ''	relative dielectric loss factor
ϵ_0	real part of vacuum permittivity
C_{so}	capacitance with the sample holder disconnection switch out
C_{si}	Capacitance with the sample holder disconnection switch in
C_0	Capacitance of the sample holder without sample
C''	Capacitance on the right hand side of the bridge [27]
D_{so}	Loss reading with the sample holder disconnection switch out
D_{si}	Loss reading with the sample holder disconnection switch in
ρ	Density of Sample

\bar{x} an average value of the loss readings
s standard deviation

CHAPTER I

INTRODUCTION

In polymer processing, moisture control is a very important task, especially for condensation polymers such as polyamides (i.e. nylon) and polyesters. For example, nylon 6/6 can absorb as much as 8.5% moisture by weight at 23°C [1]. When granular nylon 6/6 with a moisture content greater than the optimum level is processed by extrusion, chain scission by degradation occurs due to hydrolysis. The hydrolysis of polymers is a mechanism in which cleavage of the backbone of a polymer chain occurs due to the presence of water. (Detailed mechanisms are discussed in Appendix A1.) As a result of chain breakage, the average molecular weight decreases. The reduced molecular weight in turn lowers the tensile strength. On the other hand, granular nylon 6/6 with a moisture content less than the optimum level (in some cases, the optimum moisture level is below 0.02% by weight) cannot be extruded due to the large increase in viscosity. The control of the moisture content is, therefore, a major concern in the polymer processing industry, because it affects the processability of the polymer and the mechanical property of the resulting end product.

Usually granules of polymers are supplied to the manufacturer with excess moisture. Therefore, before any process could be carried out, they have to be dried in order to lower their moisture content. The amount of water absorbed frequently determines the length of

time required to dry the resin at a given temperature and a given relative humidity. Such drying periods can vary from a few hours to a few days. Most of the time, prior to processing, quantitative determination of the moisture level of the resin is desirable. Any devised technique, to be useful in a plant, must be quick, simple, and utilize inexpensive equipment.

A simple technique for moisture measurement is called the test tube/hot block technique (TTHB) [2]. It is based on the fact that the moisture present in the resin will vaporize when melted in a closed test tube. This moisture will condense, as it cools, in the form of tiny water droplets, on the side of the glass tube. The surface area, covered by this condensation on the tube, can then be correlated directly to the moisture content in the virgin resin.

Another technique is called T.V.I. after the engineer who developed it [3]. In brief, this method entails heating a few pellets of polymer to their melting point and observing whether bubbles are present as an indication of moisture in the resin.

However, both of these simple methods are qualitative. It is readily seen that both are subject to many variables and open to considerable error whenever accurate moisture data are necessary.

The traditional technique for accurate analysis of moisture in polymer (ASTM Method D-789) involves a vacuum distillation followed by Karl-Fisher titration of the moisture. This method is not only time consuming and costly due to the reagents used but demands also delicate laboratory techniques [4,5].

A widely used method for accurate analysis of moisture in polymers is called moisture evolution analysis [6,7]. The sample is heated to an operator controlled temperature in an oven to drive off any water. Moisture from the heated sample is picked up by a continuously flowing stream of externally dried nitrogen and is carried into an electrolytic cell to determine the moisture content. Although relatively simple, this method still requires an hour of analysis time, accurate weighting of the sample, and is not amenable to use as an on-line process control technique.

An NMR (Nuclear Magnetic Resonance) method has been used to determine the moisture content of plastics, molding powders, fillers, etc. [8-11]. This technique has two major drawbacks. Besides being an off-line method, the NMR signal has relatively low sensitivity : " ... one cannot detect less than a few percent concentration of magnetic nuclei in a sample whereas the dielectric measurement may be sensitive to a much smaller proportion of re-orienting dipoles [11]." For example, 1% water in wool [8], $7 \pm 0.3\%$ water in potato powder [9], and $1 \pm 0.5\%$ water in Kapron [10] were the lowest detectable moisture levels accomplished by the NMR method.

The unbound moisture content of many dielectric materials can be accurately measured with microwave techniques [12]. Microwaves are strongly absorbed by water molecules because water exhibits a broad band rotational relaxation in the microwave region. More specifically, a pronounced absorption occurs at frequencies just above 10 G Hz. Since many completely dry host materials are quite transparent in the same frequency range, a moisture-measuring technique is possible.

This technique has found wide use for both continuous process and laboratory sample tests of plastics and ceramics. The main disadvantage, however, is the reduced sensitivity at low moisture levels, particularly at moisture content less than 1% where a substantial percentage of the water molecules is bound to the polymeric chains.

Moisture control systems based on the dielectric principle are now commercially available such as the MCS 401 manufactured by Moisture Control System Inc. The MCS 401 system is designed based on the dielectric principle; "... the dielectric constant of most materials without water varies between 2 and 5 while the dielectric constant of water is approximately 81. Therefore, the presence of varying amounts of water in a known material causes a corresponding change in the dielectric constant [12]." This system, however, cannot measure low moisture levels in polymers for reasons to be discussed later on in this thesis.

This thesis describes a new accurate method for measuring the moisture content of dielectric materials such as polymers. The technique devised is particularly suited for the measurement of minute moisture levels in polymers and for on-line continuous monitoring of moisture levels.

CHAPTER II

LITERATURE REVIEW

II-A. NYLON 6/6

One of the sponsors of the M.I.T.-Industry Polymer Processing Program, AMP Inc., was interested in determining the moisture levels in nylon 6/6. Hence, the major portion of the investigation was carried out with nylon 6/6 (polyhexamethylene adipamide).

Nylon 6/6 is synthesized by reacting solutions of adipic acid and hexamethylene-diamine to form a salt, hexamethylene diammonium adipate. The concentrated salt is then polymerized, extruded between chilled rolls, and finally pelletized. During part fabrication, these pellets are injection molded into the desired configurations.

The structural repeat unit (i.e., mer) of nylon 6/6 is as follows:

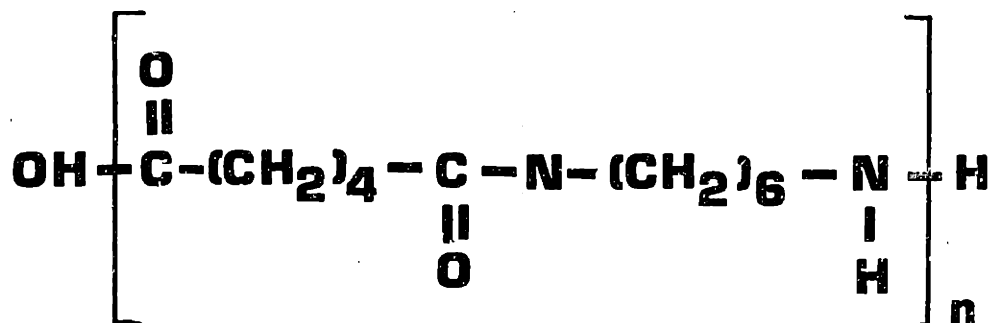

The physical properties of nylon 6/6 are dominated by the intermolecular hydrogen bond (shown here as a dotted line).

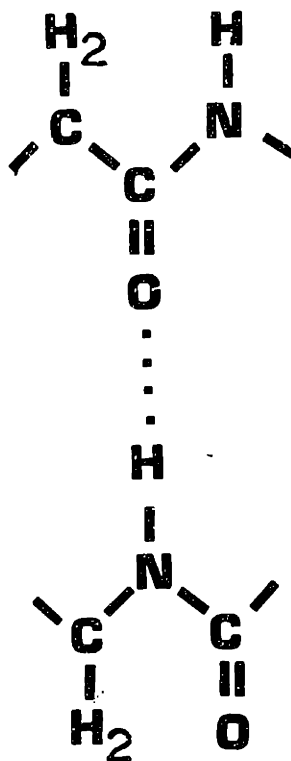

Infrared studies show that the extent of hydrogen bonding in polyamide at room temperature is essentially complete over 99% [14]. Since the water molecule has a strong tendency towards hydrogen bonds, and nylon's physical properties are controlled by the intermolecular hydrogen bonds, the physical properties of nylon 6/6 should be influenced by the quantity of water absorbed. For example, the volume resistivity (ASTM - D257) of nylon 6/6 is 10^{15} ohm - cm when

dry, 10^{13} ohm - cm at 50% relative humidity (R.H.), 10^9 ohm - cm at 100% R.H. [15]. Nylon 6/6 absorbs approximately 3% and 8.5% moisture at 50% R.H. and 100% R.H., respectively [16]. This corresponds to a four order of magnitude difference in the volume resistivity. This difference is used in the D.C. measurement method to characterize the moisture content in nylon.

Some mechanical properties are also affected by the amount of moisture absorption. As the moisture level increases, the modulus and yield strength decrease while the impact strength and toughness increase. Some dimensional changes will also occur with the increasing moisture level [17].

All polyamides are hygroscopic by nature. Before discussing in detail the mechanics of moisture intake, some back ground dielectric terminology is reviewed in the next section.

II - B: Dielectric Terminology [18]

Consider an ideal capacitor placed in a circuit with a sinusoidal voltage source as shown in Figure 1. The charging current will lead the voltage by a phase angle of 90° .

$$I_c = \frac{dQ}{dt} = j\omega C_0 V$$

where,

I_c = charging current

Q = charge

C_0 = capacitance of ideal capacitor

V = sinusoidal voltage source

ω = angular frequency

When the capacitor is filled with a dielectric material, the capacitance will increase and induce a loss current in phase with the voltage. The total current traversing the capacitor will no longer be exactly 90° out of phase with the applied voltage as shown in Figure 2. Therefore, the total current is the sum of a charging current and a loss current.

$$I = I_c + I_L = j\omega \epsilon^* C_0 V$$

where,

I = total current

I_L = loss current

$$\epsilon^* = \epsilon' - j \epsilon'' = \text{complex permittivity}$$

$$\epsilon' = \text{dielectric constant}$$

$$\epsilon'' = \text{dielectric loss factor}$$

Also, the complex relative permittivity is defined as follows:

$$\kappa^* = \kappa' - j\kappa'' = \frac{\epsilon^*}{\epsilon_0}$$

where,

$$\kappa' = \frac{\epsilon'}{\epsilon_0} = \text{relative dielectric constant}$$

$$\kappa'' = \frac{\epsilon''}{\epsilon_0} = \text{relative dielectric loss factor}$$

$$\epsilon_0 = \text{real part of vacuum permittivity}$$

The ratio of loss current to charging current is defined as the loss tangent ($\tan \delta$) or dissipation factor, that is:

$$\text{Dissipation Factor} = \tan \delta = \frac{\kappa''}{\kappa'} = \frac{\epsilon''}{\epsilon'} = \frac{I_L}{I_C}$$

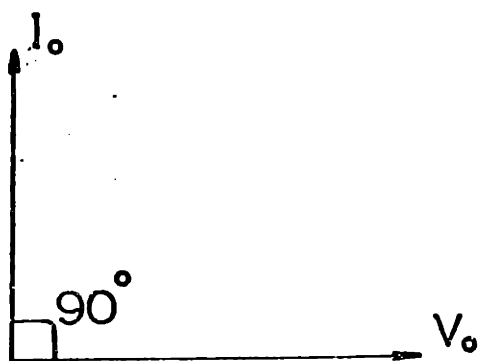
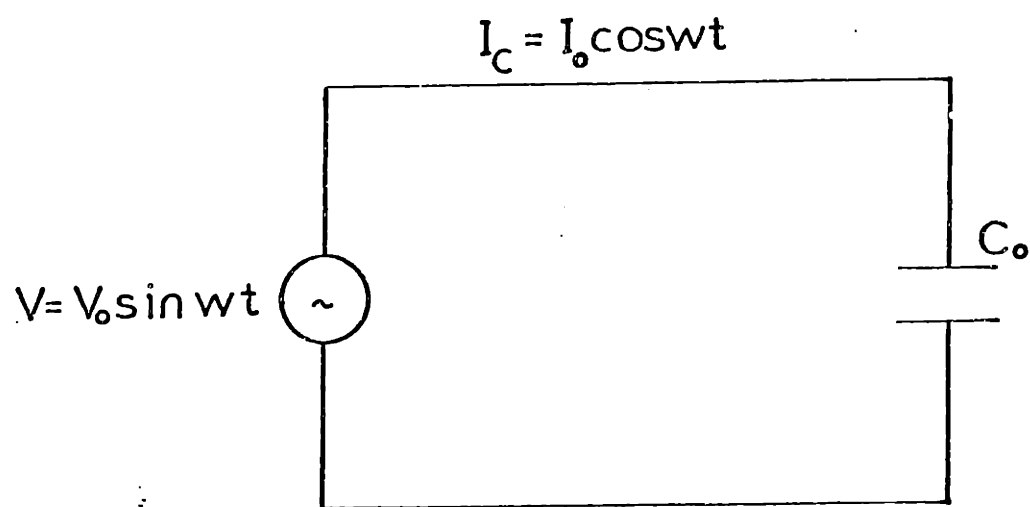

FIGURE 1: Ideal capacitor in series with a sinusoidal voltage source

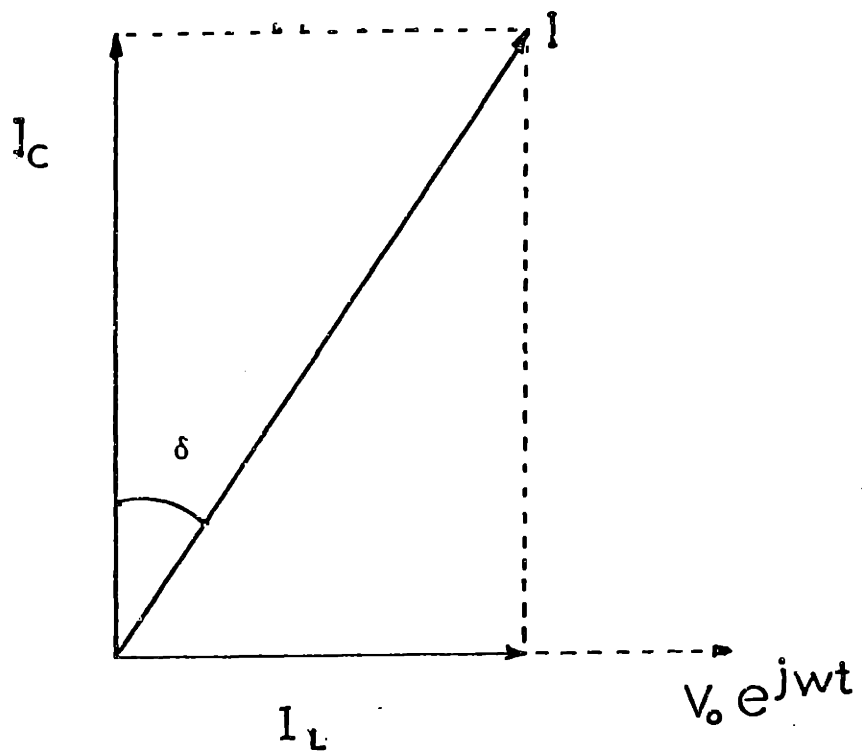

FIGURE 2: Vector diagram of the current through a dielectric

II-C. NATURE OF WATER ABSORPTION

The water molecule is relatively small and tends to form hydrogen bonds with other polar groups. Nylon 6/6, for example, contains four kinds of polar groups - CO, NH, NH₂ and OH. The water molecule can bind to the nylon chain in various ways and, as yet, the nature of this phenomenon is not fully understood. Nevertheless, a possible and perhaps dominant water bonding mechanism in nylon 6/6, especially at low moisture levels, is presented below.

Golling [32] has concluded from nuclear magnetic resonance studies that with a water content up to 0.5% the water molecules are firmly bound to the polyamide. The absorption centers are evidently nitrogen atoms. As the water content increases from 0.5% to 8% by weight, the mobility of the water molecules gradually increases and approaches that of free water molecules.

Papir et al. [19] reported that in nylon 6, water can exist under two forms, one tightly bound and the other loosely bound to the polymer chain. They observed an abrupt change in the properties of all six relaxation processes, as well as in the stress relaxation behavior, occurring at a moisture content of 2% by weight.

At some low moisture level, the absorbed water molecules appear to be firmly held to the polyamide. These water molecules make hydrogen bridges between the C = O and the N - H [20].

If the water molecules were to be firmly bound, they would not be able to exhibit the rotational relaxation in the microwave region as would unbound water molecules. In this case, measurement by microwaves of the bound water would be unsuccessful.

Nylon should contain less than 0.3% water before molding or extrusion for satisfactory performance [17]. Since a low moisture level in nylon processing is required, any moisture measurement technique, to be useful, must be able to detect the bound water molecules. Due to these bound water, there appears to be a moisture-sensitive dielectric relaxation in nylon 6/6, which could be useful for moisture characterization. These moisture-sensitive dielectric properties will be discussed in detail in the next section.

II-D. MOISTURE - SENSITIVE RELAXATION

Curtis [21] reported that the dielectric relaxation process of nylon 6/6 at about 10K Hz. and at room temperature is a very water-sensitive process. He concluded that this dielectric relaxation resulted from the water/polymer association rather than from the end groups (amine and carboxyl groups). He based his observation on the fact that process could be made to reappear immediately following the absorption of a small amount of water.

Rushton and Russell [22] illustrated the moisture-sensitive relaxation with its peak at around 10K Hz. They showed that the dielectric permittivity does not vary very much with the moisture content. This is one reason why commercially available moisture measuring device MCS 401 [12], which relies on the difference in the dielectric permittivity cannot measure the low moisture levels in polymers.

Baker and Yager [23] made extensive dielectric measurements on polyamides, and showed the effect of absorbed water on frequency dependence of the dielectric constant and the loss factor. The extraordinary dielectric properties of polyamide have been explained in terms of hydrogen bridging and the motion of charged hydrogens in these bridges. They also showed that raising the temperature alone would give the same end result as adding strong hydrogen bonding agents to the polymer at ordinary temperatures. They

considered the water (a strong hydrogen bonding agent) as a plasticizing or pseudo-ionizing medium which substitutes for intermolecular polyamide bonds, and facilitates motion of the whole system [24].

Boyd [25] studied the effects of absorption by hydrogen bonding solvents, namely, water, methanol, and ethanol. These solutes have a strong plasticizing effect, as evidenced by a shift of the loss maximum to higher frequency at a constant temperature, and a reduction in activation energy. He, also, noticed the reduction in activation energy following the introduction of the first bit of solute. Hence, the plasticizing action is thought to be a result of the reduction of interchain amide-amide hydrogen bonds and also the increase of the segmental mobility by dilution.

Although a large number of investigators have studied the effects of water on the dielectric properties of polymers, no one suggested that measurements of the dielectric loss factor or the loss tangent would be useful for the determination of the moisture contents in such materials.

The dielectric loss factor or the loss tangent is not only sensitive to water but also to other hydrogen bonding solutes. These have the same deleterious effect as water in polymer processing. Thus, the measurement of the loss factor would also be useful in determining the concentration of any hydrogen bonding solutes.

The typical atmosphere in which physicochemical transformations of polymers are subjected to in standard industrial operations is moisture. Hence, measurement of the loss tangent or the loss factor

can be used as a moisture measurement parameter.

CHAPTER III

III - A: D.C. Experiments.

III - A - 1: Experimental Procedures

The electrical response of a polymer sample can be modeled using simple capacitor and resistor elements. For example, a simple model of a polymer sample is shown in Figure 3. Suppose the resistance of R_2 changes as a function of moisture content, then the decaying current, when a step voltage is applied to the sample, will vary as the moisture content in the sample varies. Knowing that the moisture content increases the conductivity, one can assume that the higher moisture content lowers the resistance of R_2 .

A circuit diagram for a polymer sample subjected to a D.C. step voltage is shown in Figure 4. When the switch is closed, the capacitor initially acts as a short circuit. During this initial time a charge is building up on the capacitor. The current that flows through the circuit is governed by equation (1).

$$i(t) = A e^{-\left(\frac{1}{R_1 C_1} + \frac{1}{R_2 C_2}\right)t} + \frac{V}{R_1 + R_2} \quad (1)$$

where $A = \frac{R_2 V}{(R_1 + R_2) R_1}$

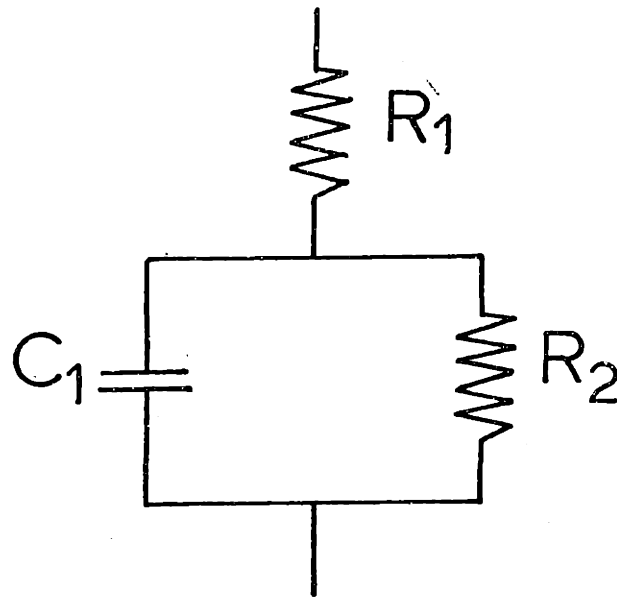

FIGURE 3: Simple model of a polymer sample

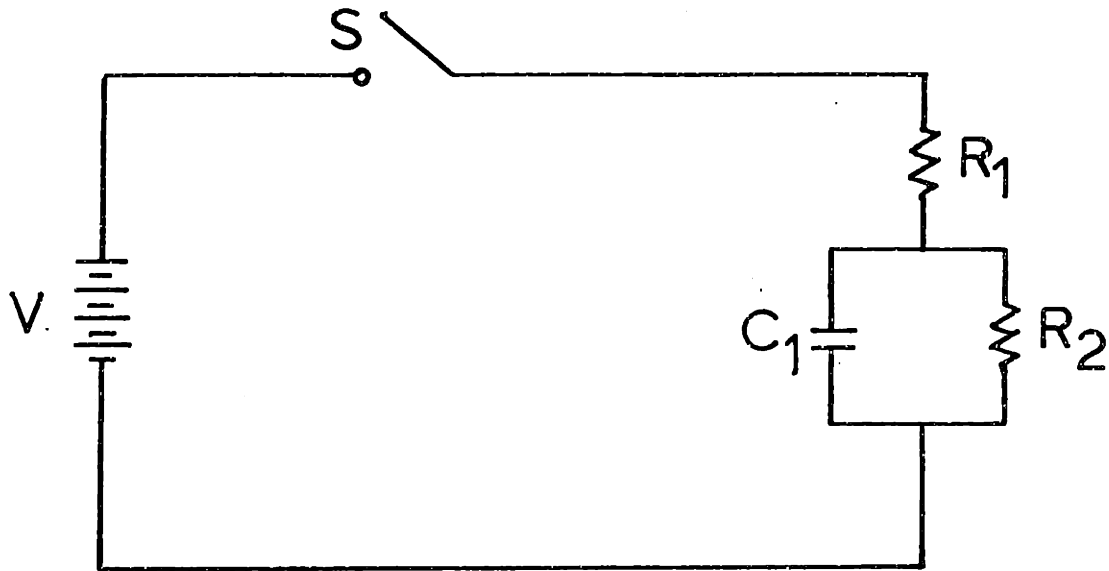

FIGURE 4: Circuit diagram for a polymer sample subjected to a D.C. step voltage

The current at $t = 0^+$ is given by equation (2).

$$i(0^+) = A + \frac{V}{R_1 + R_2} = \frac{V}{R_1} \quad (2)$$

Once the capacitor is fully charged up after the elapse of a characteristic time period, the capacitor acts as a open circuit, and the current flow will be primary through resistors. Hence, the steady state current for an ohmic conductor is given by equation (3).

$$i(\infty) = \frac{V}{R_1 + R_2} \quad (3)$$

For a given polymer, the decaying current (from $i(0^+)$ to $i(\infty)$) is expected to follow a somewhat exponential decay as shown by the dotted line in Figure 5. Thus the higher the moisture content, the small the resistance of R_2 and the expected steady state current increases as shown in Figure 6.

A circuit diagram of the apparatus is shown in Figure 7, and the corresponding experimental set-up is shown in Figure 8. From right to left, it shows an oscilloscope, an electrometer (General Radio Type 1230-A), the sample holder box (shown in Figure 9), and a power supply. The electrometer can measure a very low current, on the order of 10^{-14} amp. The sample holder box is necessary to shield the sample holder (shown in Figure 10) electrically from the background noise. In the box there is battery operated (24 volts) time-delay relay switch to prevent an overflow in the electrometer. A special switch that was

used to eliminate conduction through the switch insulator(ceramic)
is shown in the Figure 11.

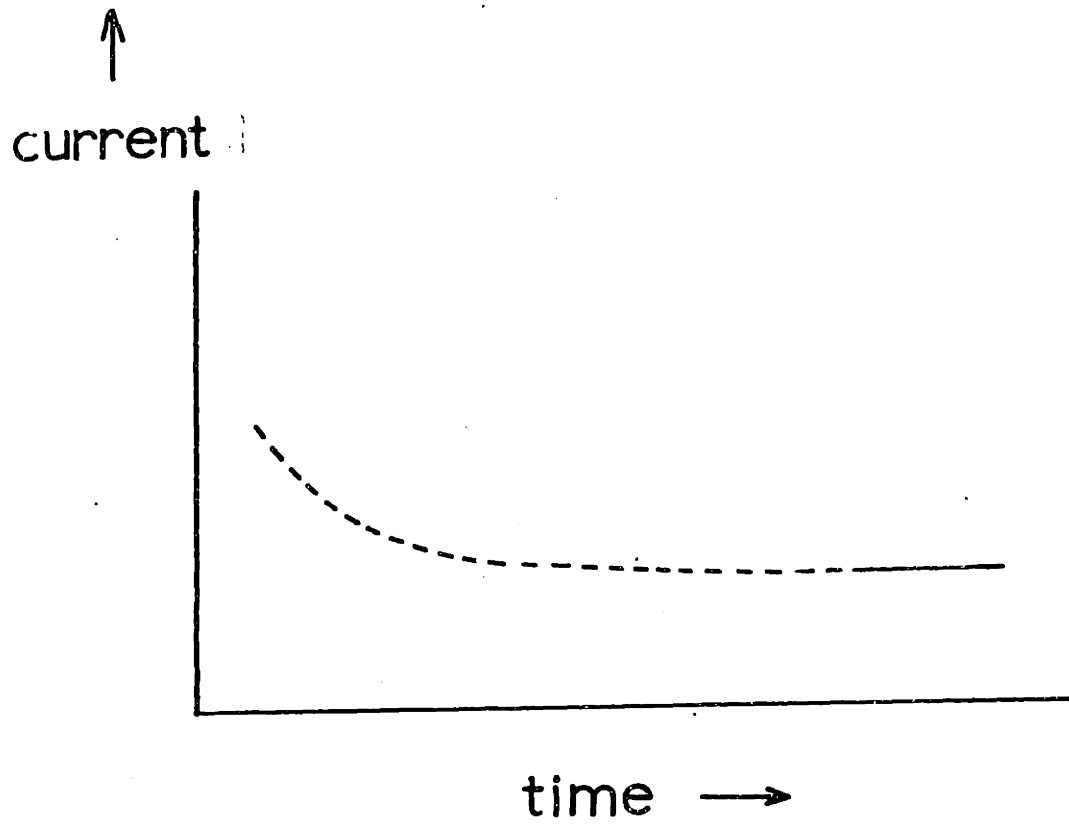

FIGURE 5: Expected current-time response of a polymer sample

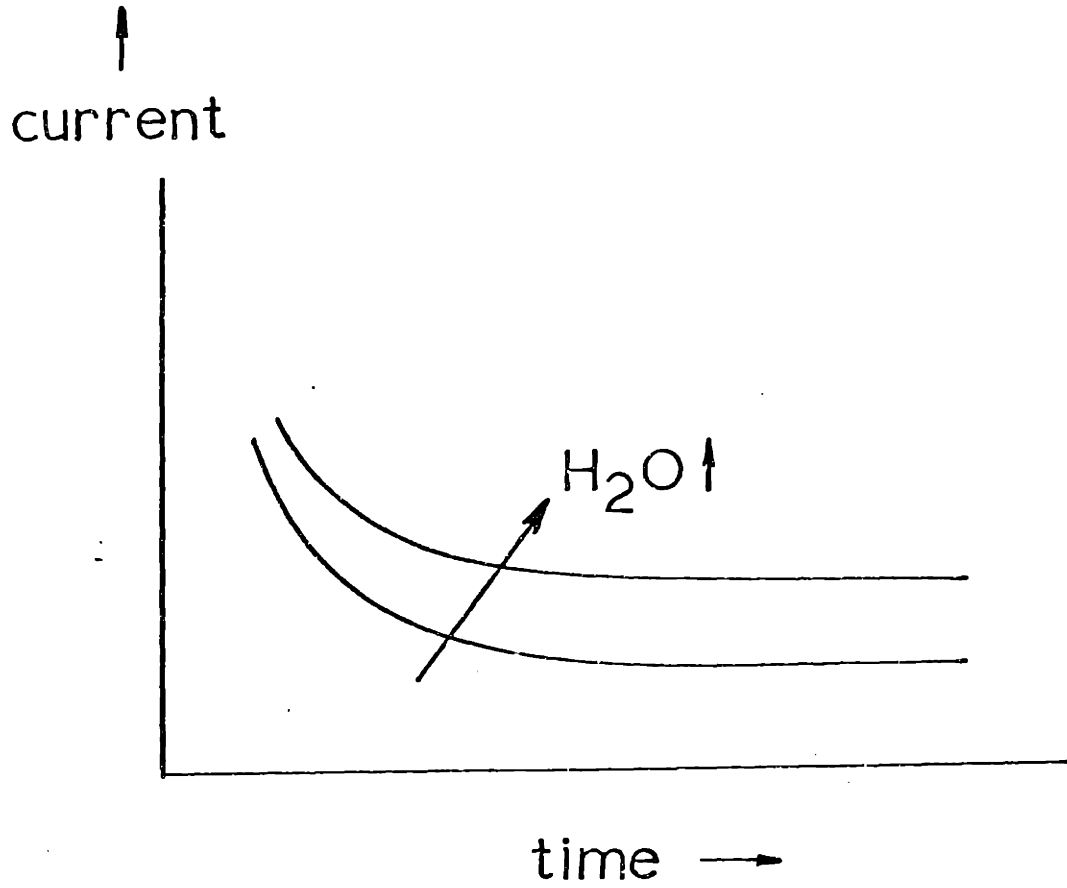

FIGURE 6: Expected current-time response of a polymer with increasing moisture level

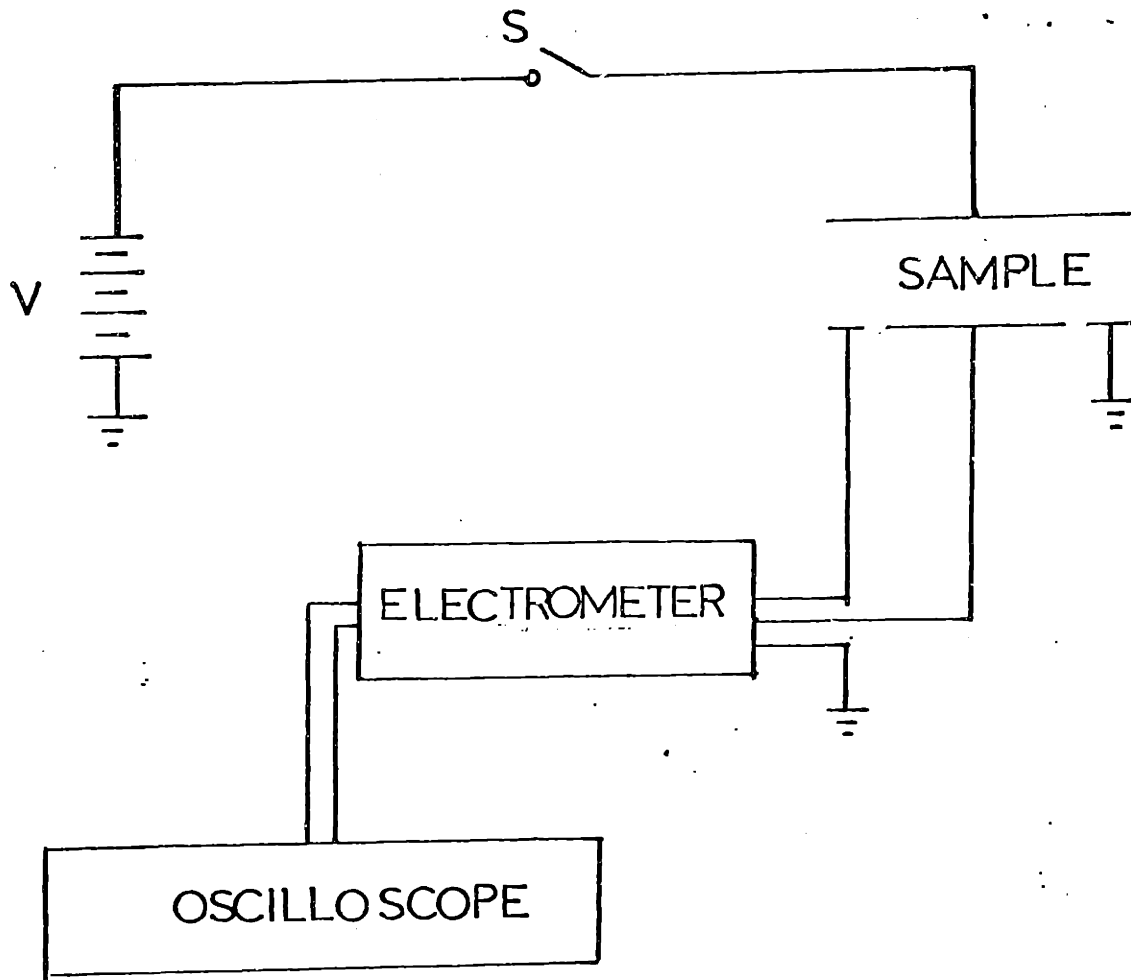

FIGURE 7: Circuit diagram of the D.C. apparatus

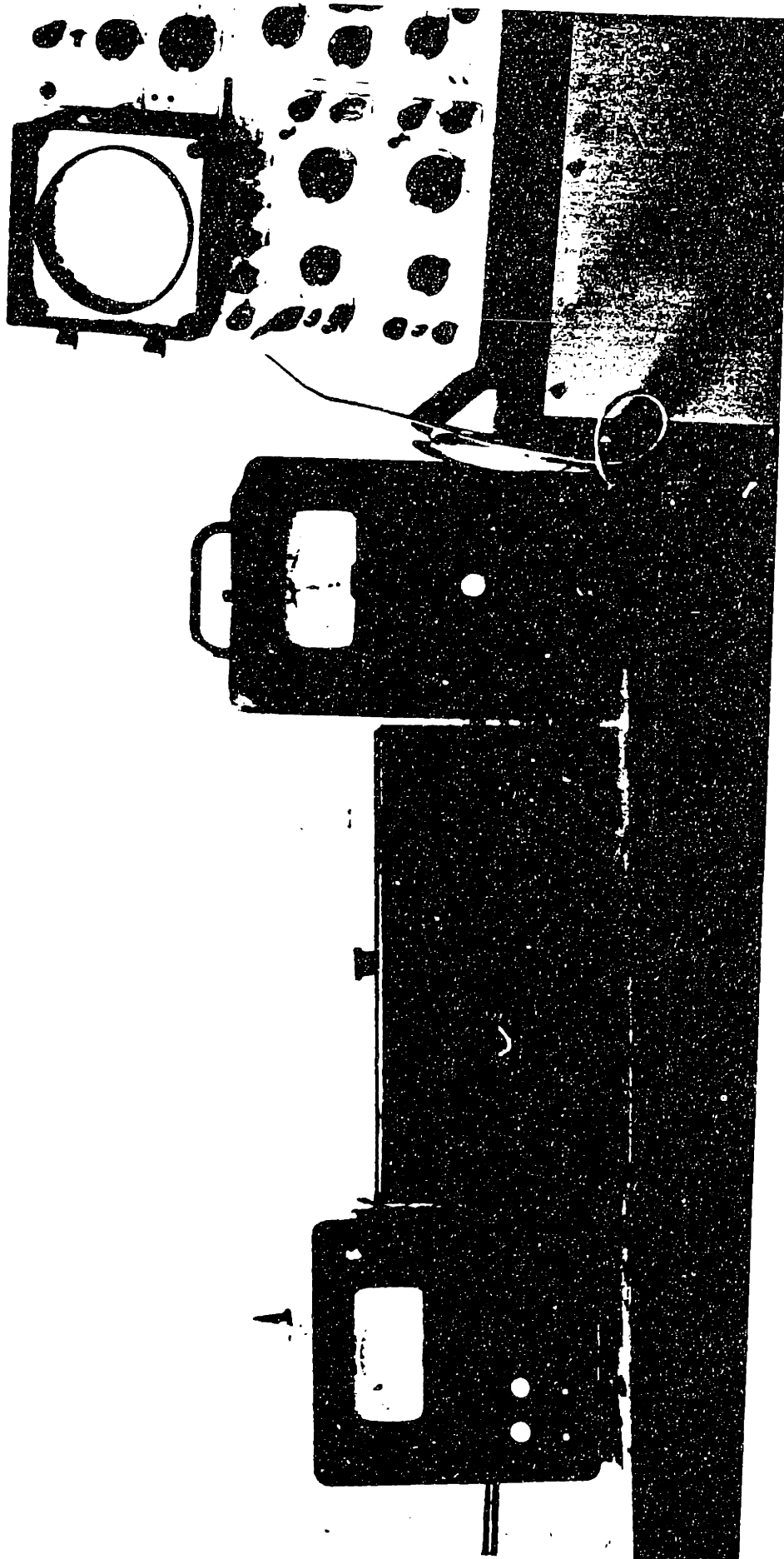

FIGURE 8: Lay out of the D.C. experiment

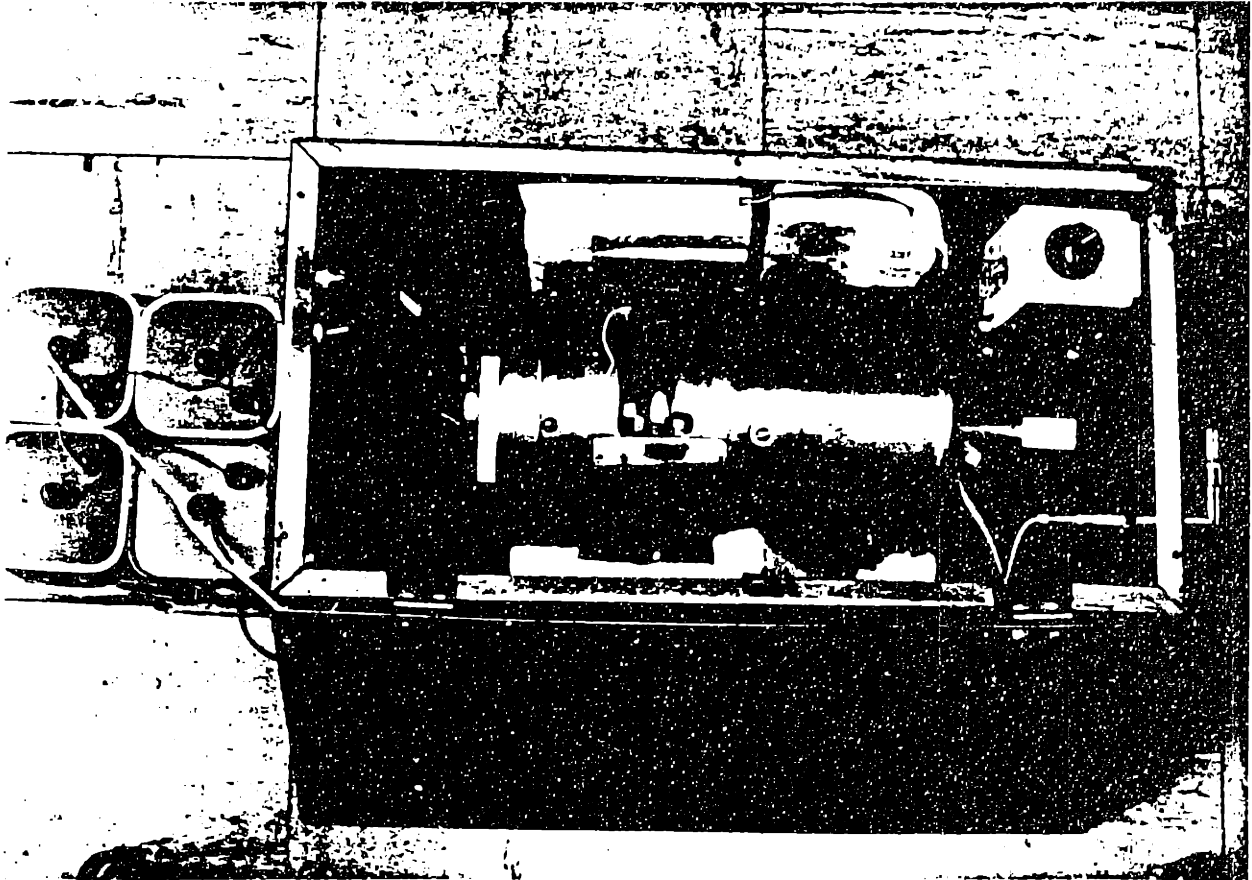

FIGURE 9: General view of a sample holder box

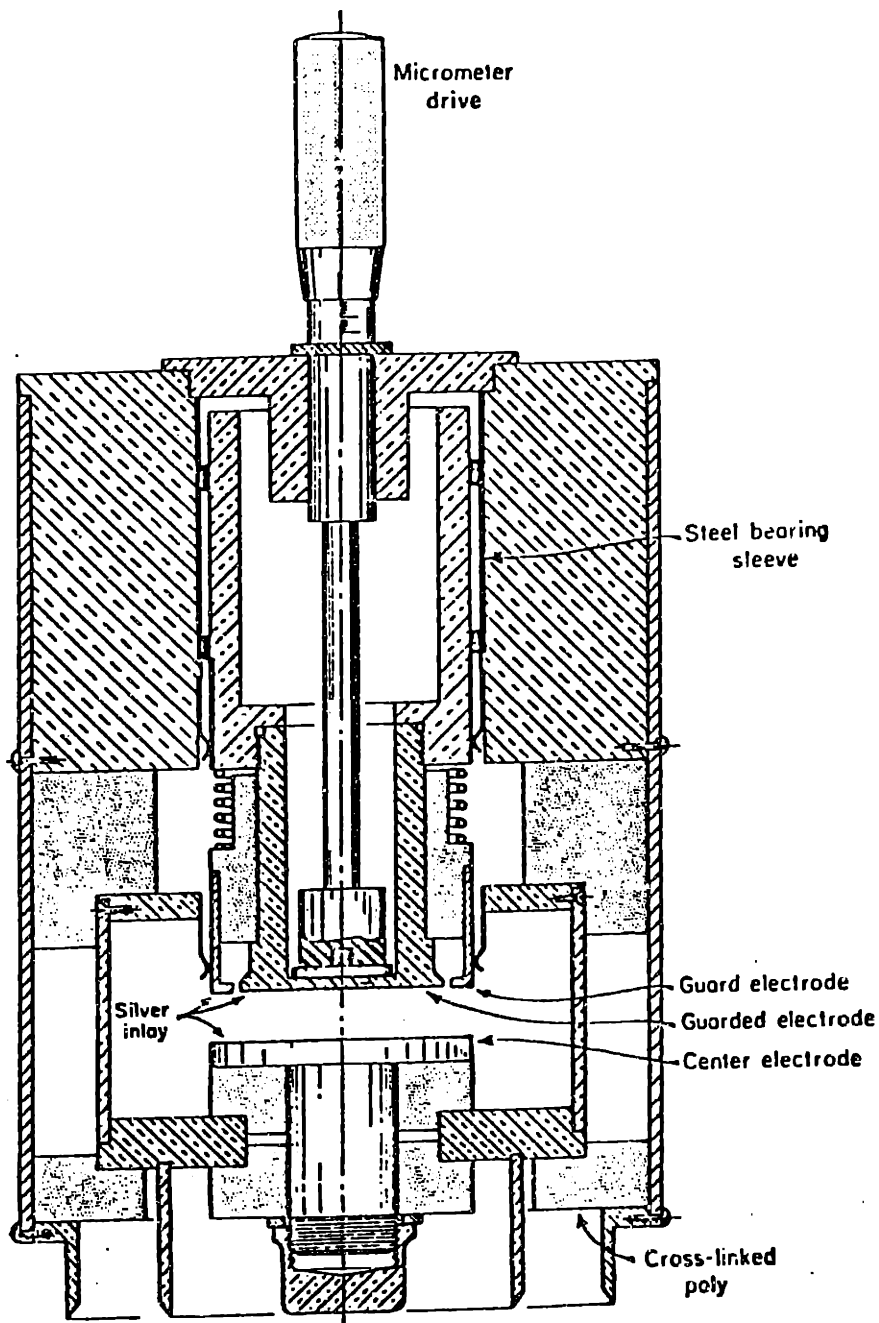

FIGURE 10: Diagram of the sample holder

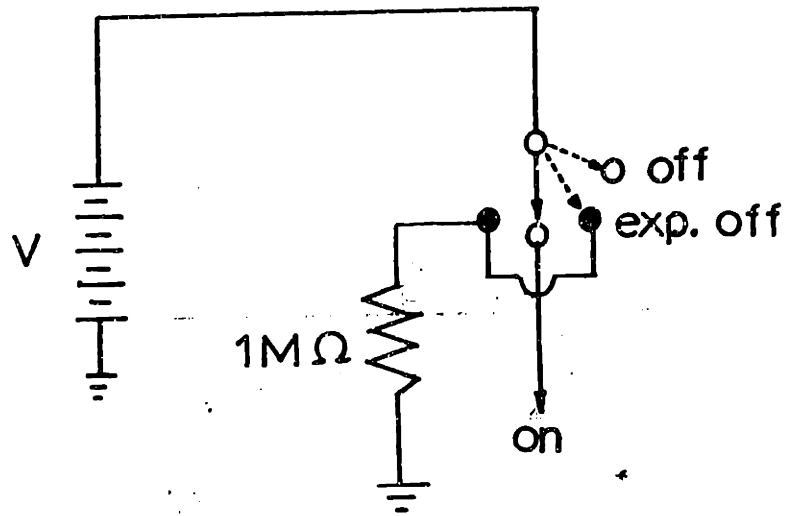

FIGURE 11: Circuit diagram of the switch

III - A - 2: Sample Preparation

Three nylon 6/6 samples were conditioned at AMP Inc. as described in Table 1. The samples were disks, 2 in. in diameter and 1/32 in. in thickness.

Although samples a, b, and c were conditioned to have equilibrium moisture contents of 0.9%, 0.7%, and 0.5% by weight, respectively, the moisture level determined by technicians at AMP Inc. using the Meeco moisture analyzer differed widely as shown in Table 2. The source of error might have been the change in the moisture content when the disk was broken into smaller pieces under ambient conditions for measurement in the Meeco analyzer.

Other disk samples were conditioned by placing them in a constant humidity desiccator. One of polyurethane samples was conditioned under ambient conditions. The conditioning of samples and their moisture levels are given in Table 3

Table 1 : Sample Conditions

sample	material	conditions
a	nylon 6/6 (Vydyne 21x)	60 ⁰ C, 72 hrs, 27% R.H.
b	nylon 6/6 (vydyne 21x)	60 ⁰ C, 90 hrs, 22% R.H.
c	nylon 6/6 (Vydyne 21x)	60 ⁰ C, 115 hrs, 17% R.H.

Table 2: Moisture data by the Meeco Analyzer

sample	measurements		average
a	0.705%	0.427%	0.566%
b	0.564%	0.644%	0.604%
c	--	--	0.48 %

Table 3: Conditioning of samples and their moisture levels

sample	material	desiccant	moisture levels	average	
d	nylon 6/6(Vydyne 21x)	NaCl	4.148%	2.749%	3.45%
e	nylon 6/6(Vydyne 21x)	P ₂ O ₅	0.221%	0.305%	0.26%
f	polyurethane (Texin)	NaCl	0.69%	0.62%	0.66%
g	polyurethane (Texin)	ambient	0.23%	0.23%	0.23%
h	polyurethane (Texin)	P ₂ O ₅	0.058%	0.095%	0.08%

III - A - 3: Results

Nylon 6/6 which were conditioned at AMP Inc. had the response as shown in Figure 12. Although the moisture levels were targeted for 0.9%, 0.7%, 0.5% by weight, their probable moisture levels would be at 0.7%, 0.6%, and 0.5%, respectively as shown in Table 2.

Nylon 6/6 conditioned in the desiccator with desiccant NaCl and P_2O_5 had the responses shown in Figure 13 and Figure 14, respectively.

The log-log plot of the current (20 sec. after the switch is closed) of thermoplastic polyurethane with three different moisture contents vs. applied voltages are shown in Figure 15. For a given moisture level, the current varies approximately linearly with the applied voltage.

current (amp)

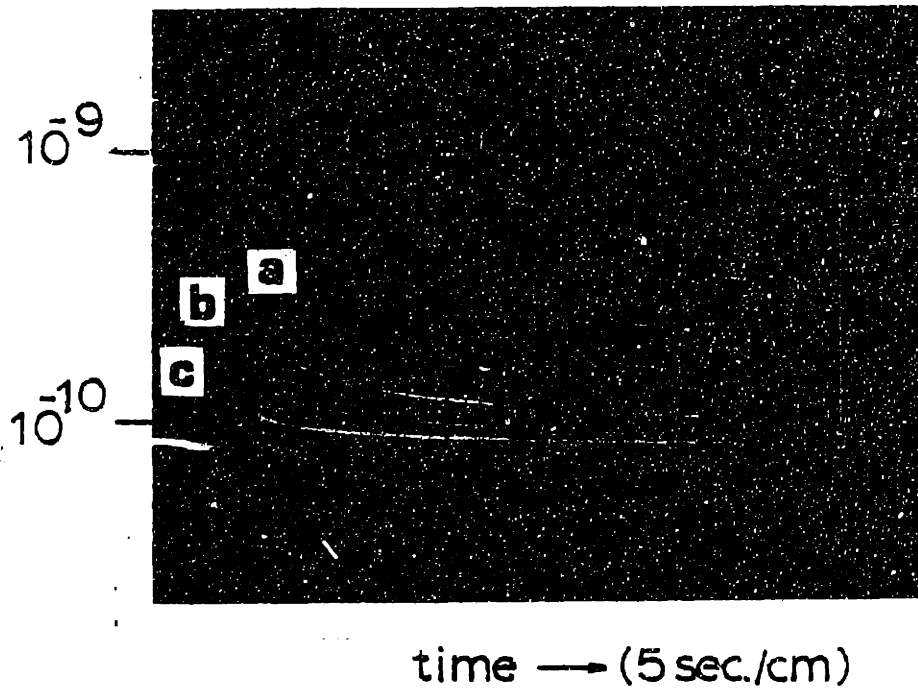

FIGURE 12: Step response of nylon 6/6 (Vydyne 21)
with three different moisture levels at 23°C
a) 0.7%, b) 0.6%, c) 0.5%

current (amp)

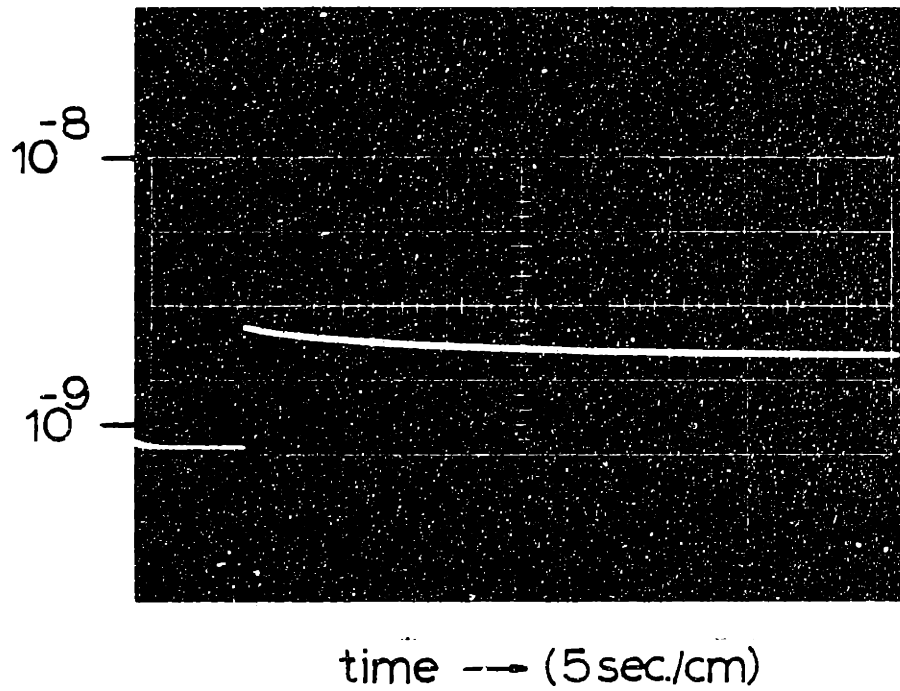

FIGURE 13: Step response of nylon 6/6
(Vydyne 21x) with 3.45% moisture,
at 23°C

current (amp)

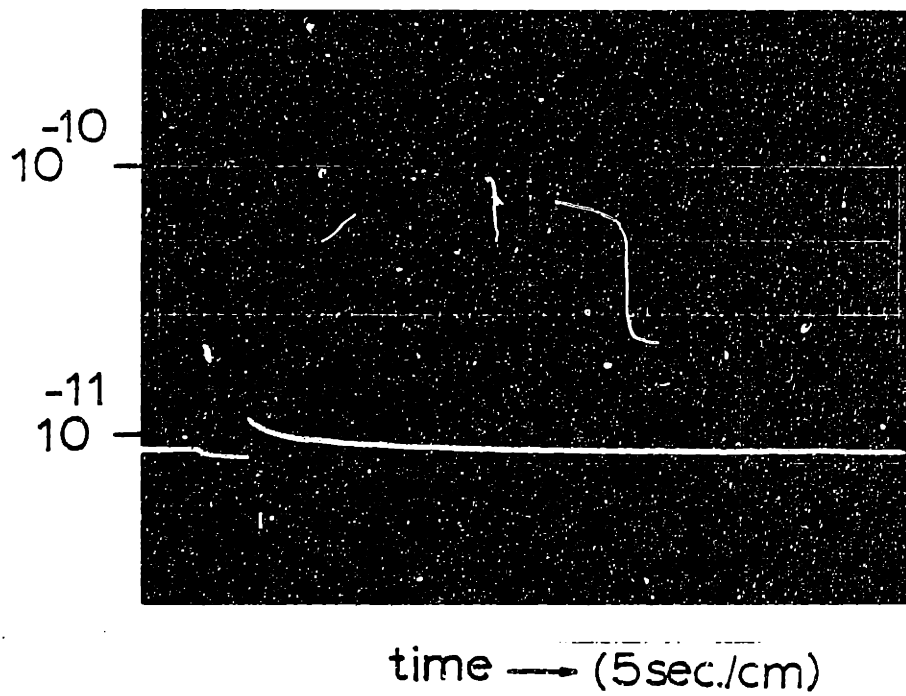

FIGURE 14: Step response of nylon 6/6
(Vydyne 21x) with 0.26% moisture,
at 23°C

CURRENT (amp)

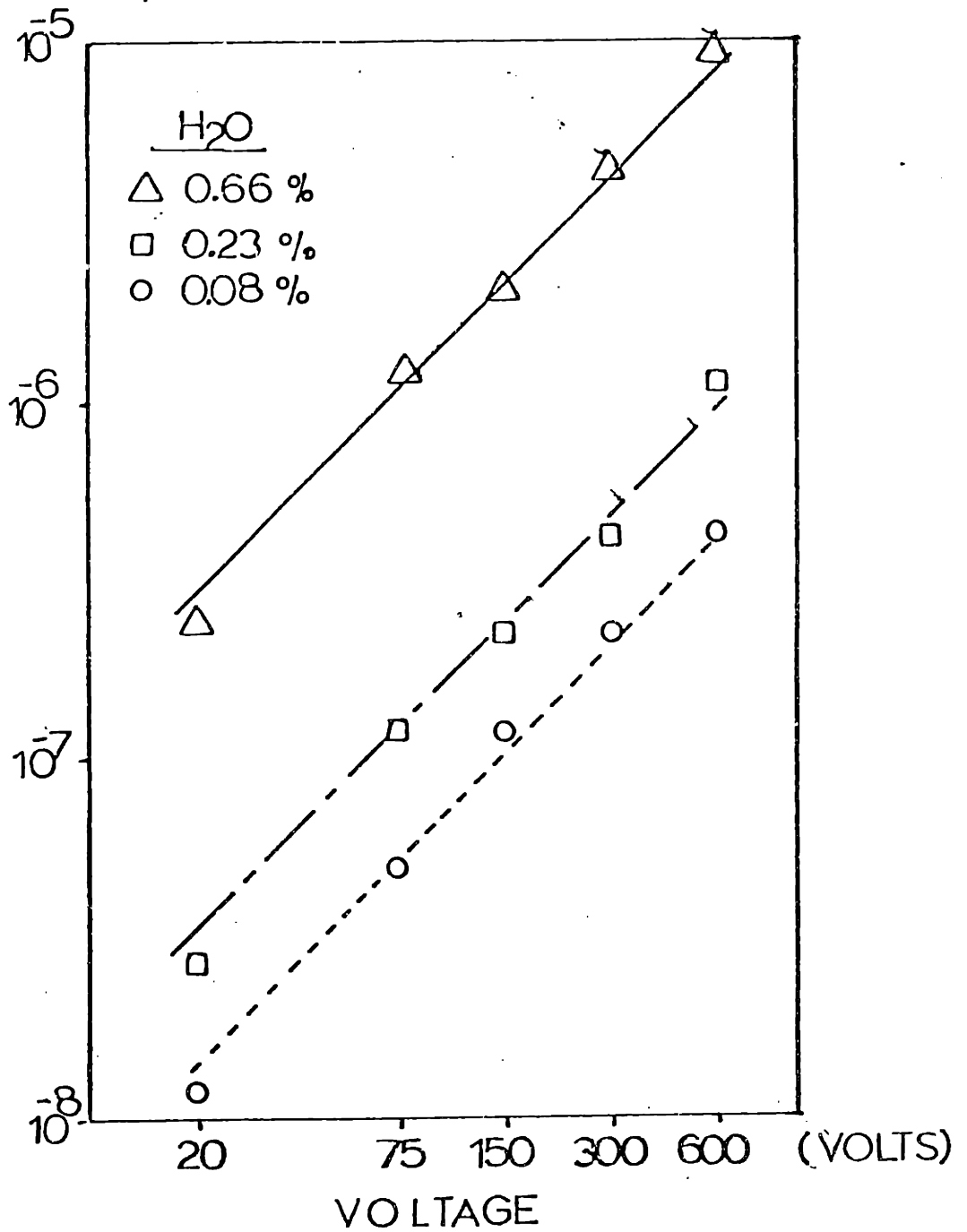

FIGURE 15 current ($t = 20$ sec.) vs. applied voltage for polyurethane at 23°C

III - B: A.C. Experiment

III - B - 1: Experimental Procedures

Three different bridges were used to cover a wide range of frequency in the dielectric loss measurements. A bridge built in the Insulation Laboratory at M.I.T. was used for frequencies less than 50 Hz. (The details of the bridge are given in Technical Report 6 [26].) For frequencies in the range of 50 Hz to 30 MHz, another bridge built in the Insulation Laboratory, described in the Technical Report 201 [27], was used. For frequencies greater than 30 MHz, a laboratory built bridge, described in the Insulation Laboratory Technical Report 182 [28], was used.

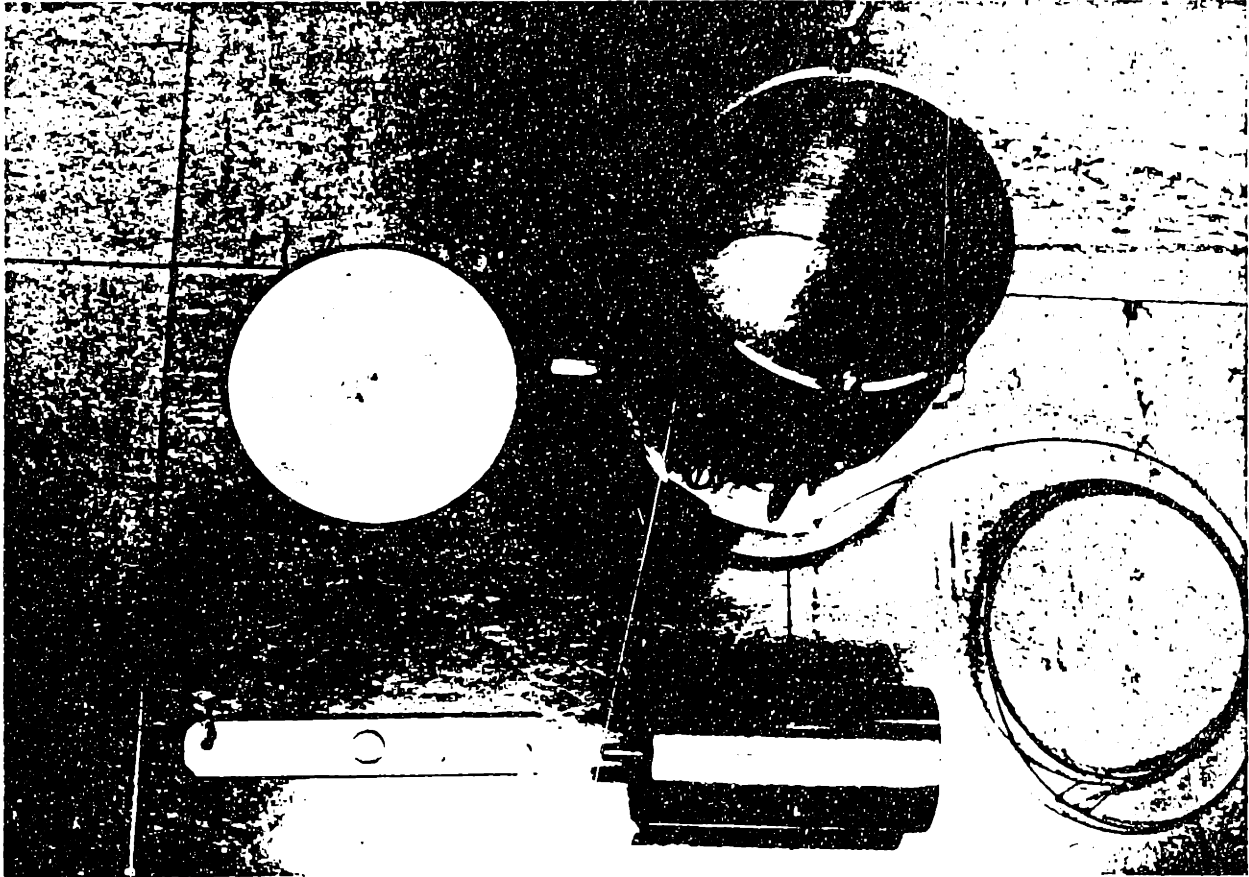

FIGURE 16 : Detailed view of the disassembled sample holder for granules

III - B - 2: Sample Preparation

Nylon 6/6 samples were prepared at AMP Incorporated. They were disks of 2 inches in diameter and 1/8 inches in thickness. Vydyne 21 is pure nylon 6/6. Vydyne 21x is nylon 6/6 with lubricant. J 120 FR is glass filled nylon 6/6 with fire retardant. The condition at which samples were prepared and their moisture levels are reported in Table 4. The moisture levels were determined by the Meeco Moisture Analyzer. In the case of glass filled material, the moisture levels were calculated, assuming that only nylon absorbed moisture.

The sample disk was coated with vacuum grease (silicon oil) and thin tin foil disks covered the both sides of sample. Vacuum grease helps the tin foil stick to the sample and retains the moisture in the sample

Granules of nylon 6/6 were conditioned to three different moisture levels by placing them in a constant humidity desiccator over a period of three months. Granules with P_2O_5 desiccant had the moisture content of 0.38% by weight; granules with LiCl desiccant had 0.86%; granules with CaCl desiccant had 1.15%.

A photograph of the disassembled sample holder for granules is shown in Figure 16. The holder had the following dimensions: inside radius of outer electrode--9.916 cm., and its height--12.725 cm., outside radius of inner electrode--5.072 cm., and its height--9.660 cm. The insulation between the two electrodes is crosslinked polystyrene.

Dissipation factors, the loss tangents ($\tan \delta$) of polycarbonate (Merlon[®]), polymethylmethacrylate (plaxiglas[®]), and thermoplastic

polyurethane(Texin[®]) were also measured. These samples were in the form of disks of 2 inches in diameter and 1/32 inches in thickness. Three different moisture levels were obtained by a) putting them in the desicator with 92% relative humidity, b) as recieved from Eastman Kodak Co., and c) by vacuum-oven drying. The moisture level of each sample was estimated from the weight difference between the sample and the dry sample.

The dielectric loss factors of polyethylene terephthalate and poly(amide-imide), Torlon were measured. The polyethylene terephthalate resins were supplied and their moisture levels were reported by Goodyear Tire and Rubber Co. The Torlon resins were supplied by Lord Corp. and their moisture contents were measured by AMP Inc.

III - B - 3: Results

Dielectric loss factor vs. frequency of nylon 6/6(Vydyne 21) are shown in Figure 17. Note the moisture-sensitive frequency near 20,000 Hz. The loss factors vs. frequency of nylon 6/6(Vydyne 21x) and nylon 6/6(U-720-FR) are shown in Figure 18 and 19, respectively. Other dielectric data are tabulated in Appendix A3.

413.1 grams of nylon 6/6 granules(Vydyne 21x) filled 4/5th of the sample holder shown in Figure 14. Since the sample holder was not filled completely with granules of the nylon sample, shaking the sample holder resulted in varying the geometry of samples' volume. To study the variation of the loss reading due to a change in the sample geometry, changes in the loss reading and capacitance reading were measured at 20,000 Hz. after the sample holder has been shaken. The dielectric constant and loss factor can be calculated from the loss and capacitance readings by equations (4) and (5), respectively [28].

$$\kappa' = \frac{(C_{so} - C_{si})}{C_o} + 1 \quad (4)$$

$$\kappa'' = \frac{C'' \times (D_{si} - D_{so})}{C_o} \quad (5)$$

where,

C_{so} = Capacitance with the sample holder disconnection switch out

C_{si} = Capacitance with the sample holder disconnection switch in

C_o = Capacitance of the sample holder without sample

C'' = Capacitance on the right hand side of the bridge [27]

D_{so} = Loss reading with the sample holder disconnection switch out

D_{si} = Loss reading with the sample holder disconnection switch in

It is also known that the following relation holds[29].

$$(\kappa' - 1) = A \times \rho \quad (6)$$

$$\kappa'' = B \times \rho \quad (7)$$

where,

A = Constant

B = Constant

ρ = Density of sample

Dividing equation (6) by equation (7), one obtains the following relation

$$\frac{\kappa' - 1}{\kappa''} = \frac{A}{B} = \frac{\Delta C}{C'' \times \Delta D} \quad (8)$$

where,

$$\Delta C = C_{so} - C_{si}$$

$$\Delta D = D_{si} - D_{so}$$

From equation (8), one can say that the ratio of ΔC and ΔD are the same even when one shakes the sample holder to change the geometry of sample thereby changing ΔC , as long as the material properties does not change. So one can compensate for the change in the value of ΔD by variation in ΔC . The compensated ΔD values are tabulated in Table 6. In comparison to the standard deviation value in Table 5, the compensated value of ΔD in Table 6 has a much smaller standard deviation.

The average values of ΔD are plotted according to their moisture levels in Figure 20. From the slope of the line in Figure 20, one can estimate the sensitivity of the moisture measurement. Since one can read the ΔD value well within ± 0.25 , one can measure the moisture level within 0.01% sensitivity. Although ΔD reading could be measured more sensitively using the micrometer attached to the bridge [27], the micrometer reading was not necessary since the sensitivity of moisture measurement done at AMP Inc. was not any better than 0.01%. More sensitive measurements can be achieved if a comparative type of measurement is used. For example, the difference in the loss factor reading for two moisture levels (i.e.,

0.23% and 0.10%) is about 0.015 at the moisture -sensitive frequency, 20 KHz as shown in Figure 17. Assuming the loss factor varies linearly with the moisture level and it varies only to the moisture, one can estimate 0.0001% (by weight) sensitivity since a comparative bridge measurement can measure the phase angle difference within 10^{-5} radiant.

A moisture sensitive frequency must be found so that the loss factor reading can be made at the frequency. The loss tangents of several polymers were measured in a hope in locate the moisture-sensitive frequency. Note that the loss factor is proportional to the loss tangent if the dielectric constant is the same. Since the change in the dielectric constant due to the absorbed moisture is negligible in the low moisture level considered, the loss tangent is approximately proportional to the loss factor. Hence, either the loss tangent or the loss factor can be used in determining the moisture levels in polymers. Also, since the value of the loss tangent ($\tan\delta$) is small, the value of angle (δ) is approximately equal to the loss tangent.

The loss tangent vs. frequency of polycarbonate, polymethylmethacrylate (PMMA), and thermoplastic polyurethane are shown in Figure 21, Figure 22, and Figure 23, respectively.

The loss factor vs. frequency of polyethylene terephthalate and poly (amide-imide) are shown in Figure 24 and Figure 25, respectively.

The moisture -sensitive frequency of polycarbonate, PMMA, polyurethane, polyethylene terephthalate, and poly (amide -imide) is around 10^7 Hz., 10^5 Hz., 10^3 Hz., 10^5 Hz., and 10^4 Hz., respectively.

The loss factor vs. frequency of polyethylene with the several moisture levels were made but not reported in this thesis. As expected, the loss factors for the different moisture level were identical. Interpretation of the result is as follows: Since polyethylene does not have any polar groups which might have a weak electrostatic force in attracting water molecules, the absorbed water is not bound to the surrounding molecules. Hence, the author predicts that a very sensitive moisture measurement is possible at the microwave frequency, more precisely around 10 GHz. This prediction is supported by the report [33] which showed the effect of moisture on dielectric loss of polystyrene at $3 \cdot 10^9$ Hz.

Table 4: Conditions of samples and their moisture levels

sample	material (nylon 6/6)	conditions	moisture level
A	Vydyne 21	Vac. dry, 80°C, 48 hrs.	0.10%
B	Vydyne 21	10% R.H., 90°C	0.23%
C	Vydyne 21	17% R.H., 60°C, 115 hrs.	0.48%
D	Vydyne 21x	4% R.H., 90°C,	0.13%
E	Vydyne 21x	17% R.H., 60°C, 115 hrs.	0.43%
F	Vydyne 21x	27% R.H., 60°C, 72 hrs.	0.56%
G	J 120 FR	4% R.H., 90°C	0.13%
H	J 120 FR	17% R.H., 60°C, 115 hrs.	0.31%
I	J 120 FR	27% R.H., 60°C, 72 hrs.	0.52%

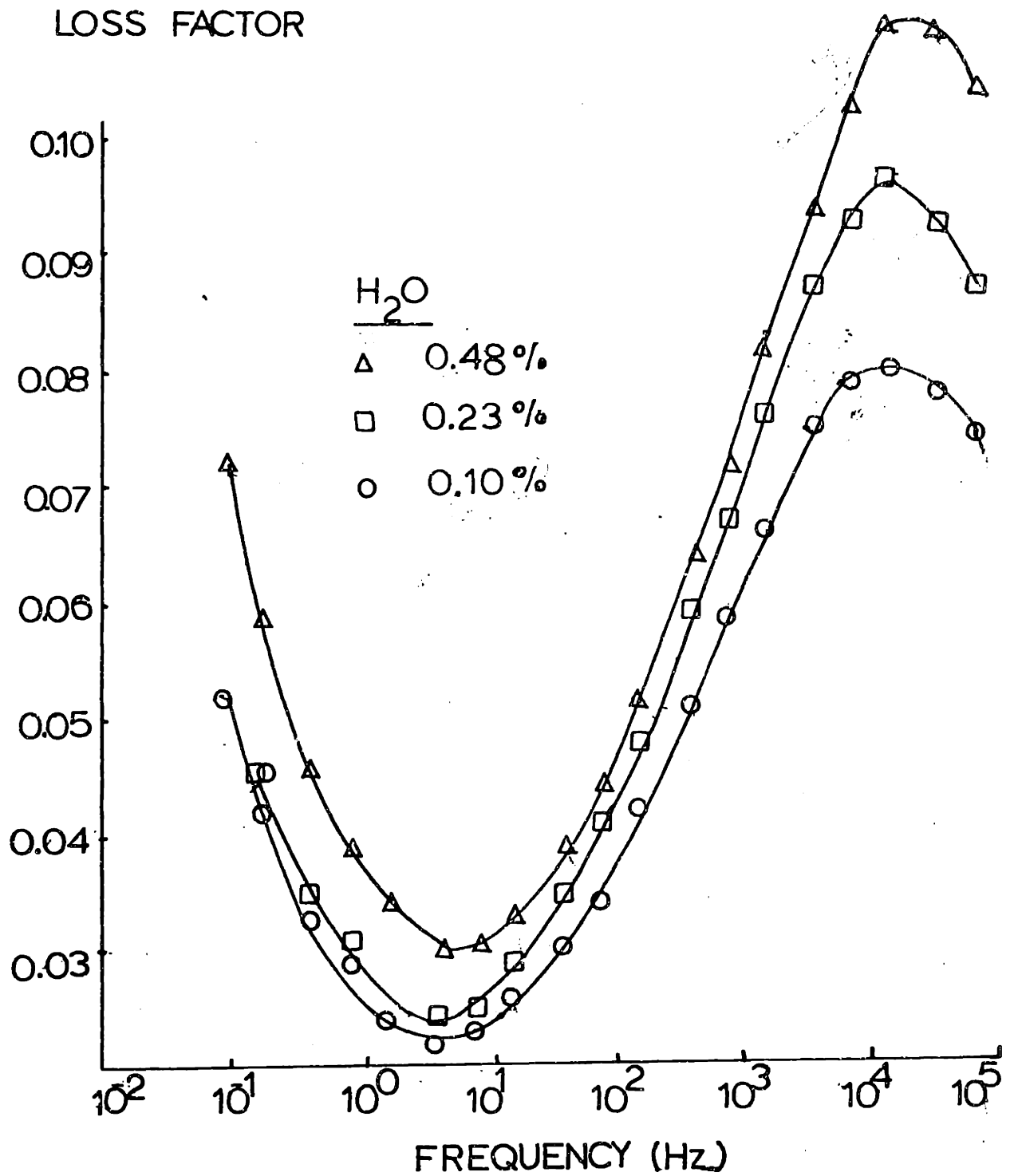

FIGURE 17: Loss factor vs. frequency for nylon 6/6
(Vydyne 21) at 23°C

LOSS FACTOR

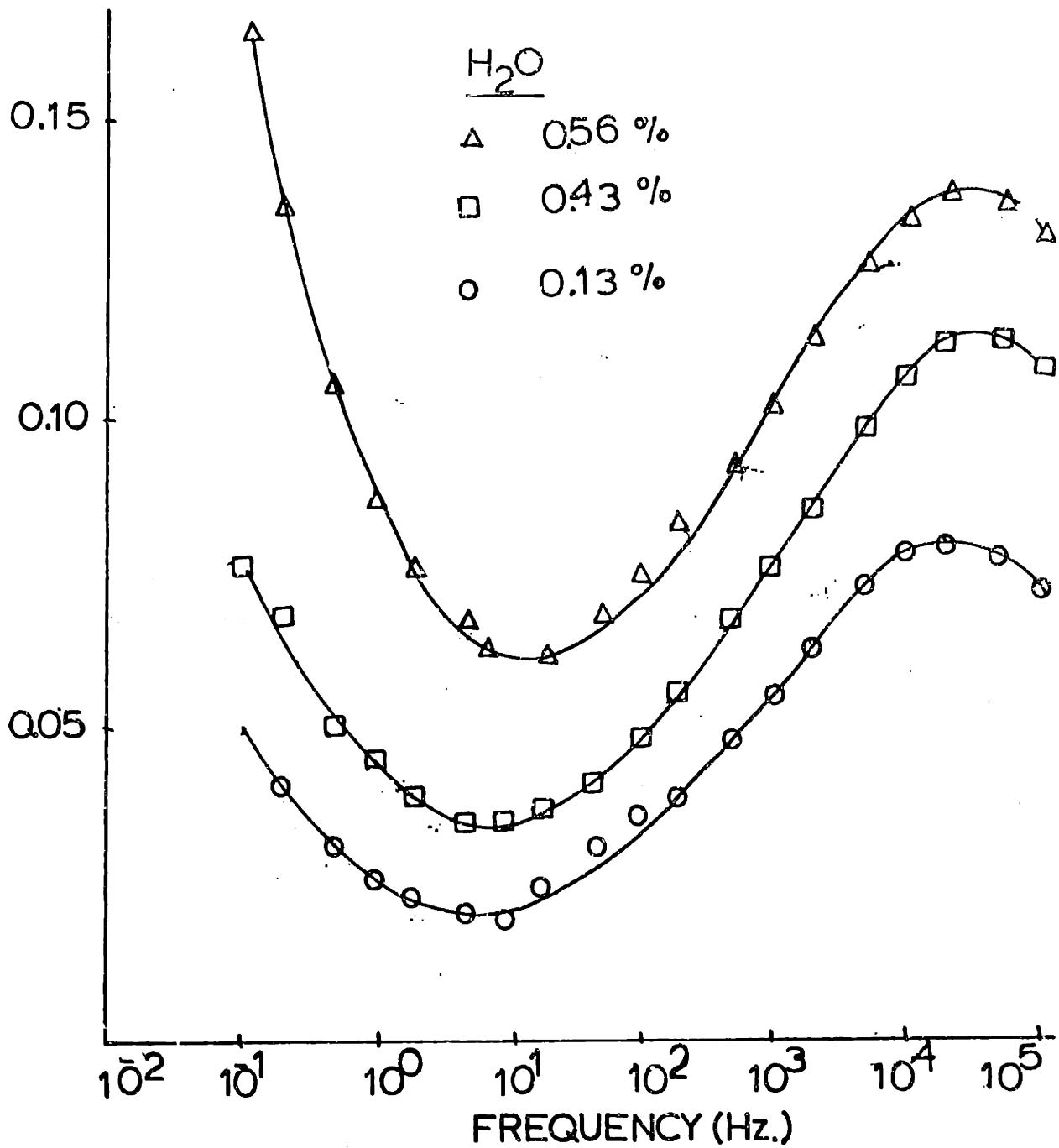

FIGURE 18: Loss factor vs. frequency for nylon 6/6
(Vydyne 21x) at 23°C

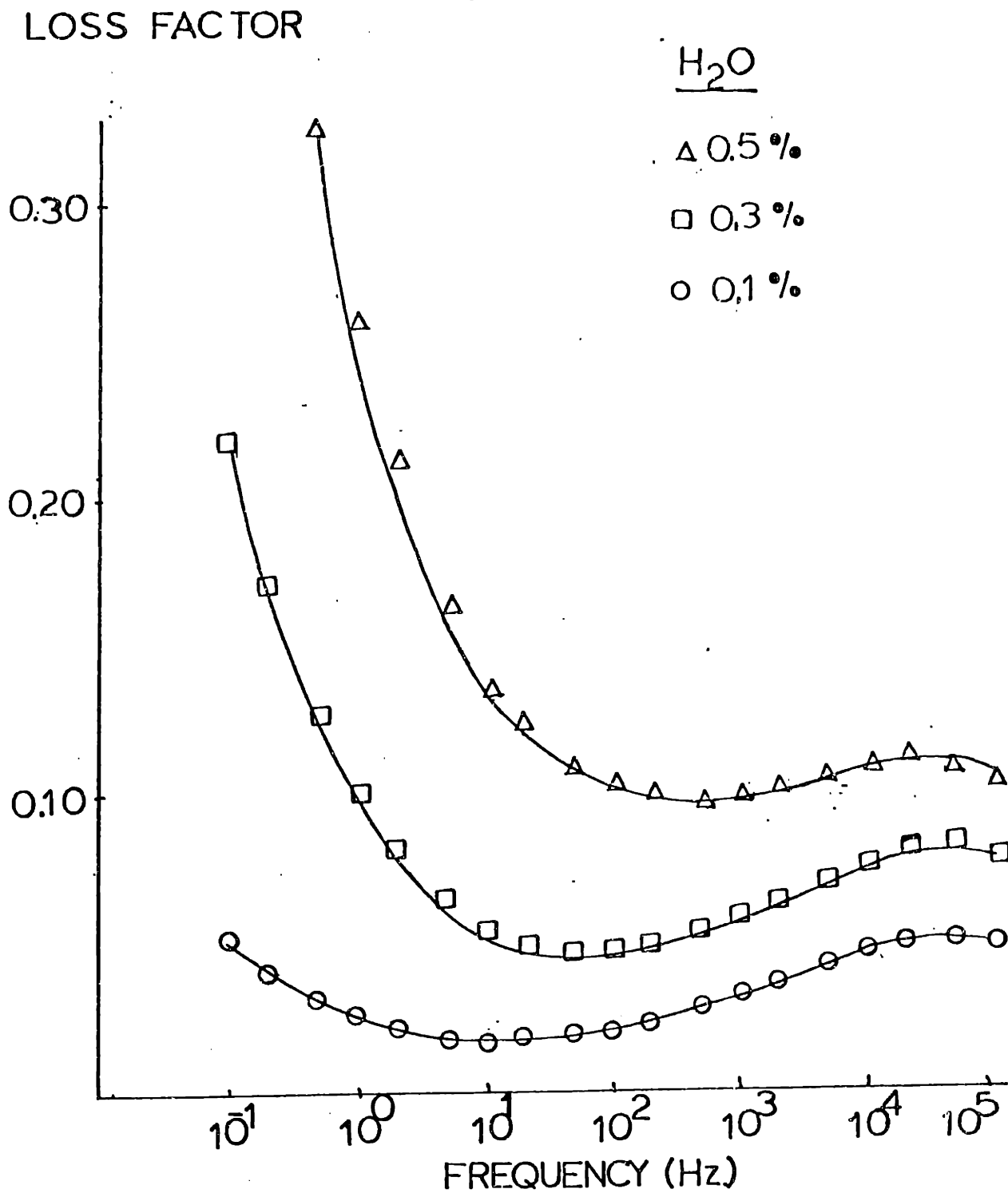

FIGURE 19; Loss factor vs. frequency for nylon 6/6
 (J 120 FR) at 23°C

Table 5: Readings of ΔD & ΔC after the sample holder has been shaken

0.38% H ₂ O		0.86% H ₂ O		1.15% H ₂ O	
ΔD	ΔC	ΔD	ΔC	ΔD	ΔC
45.3	57.96	65.1	60.59	*78.6	62.85
45.5	58.11	64.9	60.34	78.8	62.49
45.5	58.12	66.2	61.16	79.1	62.79
44.6	57.19	66.4	61.43	79.5	63.06
45.4	58.16	66.6	61.69	79.4	63.00
45.4	58.26	66.7	61.50	*79.8	61.16
--	--	66.5	61.50	--	--
$\bar{x} = 45.28$		$\bar{x} = 66.1$		$\bar{x} = 79.2$	
$s = 0.34$		$s = 0.74$		$s = 0.32$	

* omitted because of questionable validity

Table 6: Compensated ΔD values

0.38% H ₂ O	0.86% H ₂ O	1.15% H ₂ O
45.30	65.7	*78.52
45.38	66.6	79.18
45.37	66.2	79.10
45.20	66.1	79.23
45.24	66.0	79.13
45.17	66.1	*81.85
--	66.1	--
$\bar{x} = 45.28$	$\bar{x} = 66.1$	$\bar{x} = 79.2$
$s = 0.09$	$s = 0.27$	$s = 0.06$

* omitted because of questionable validity

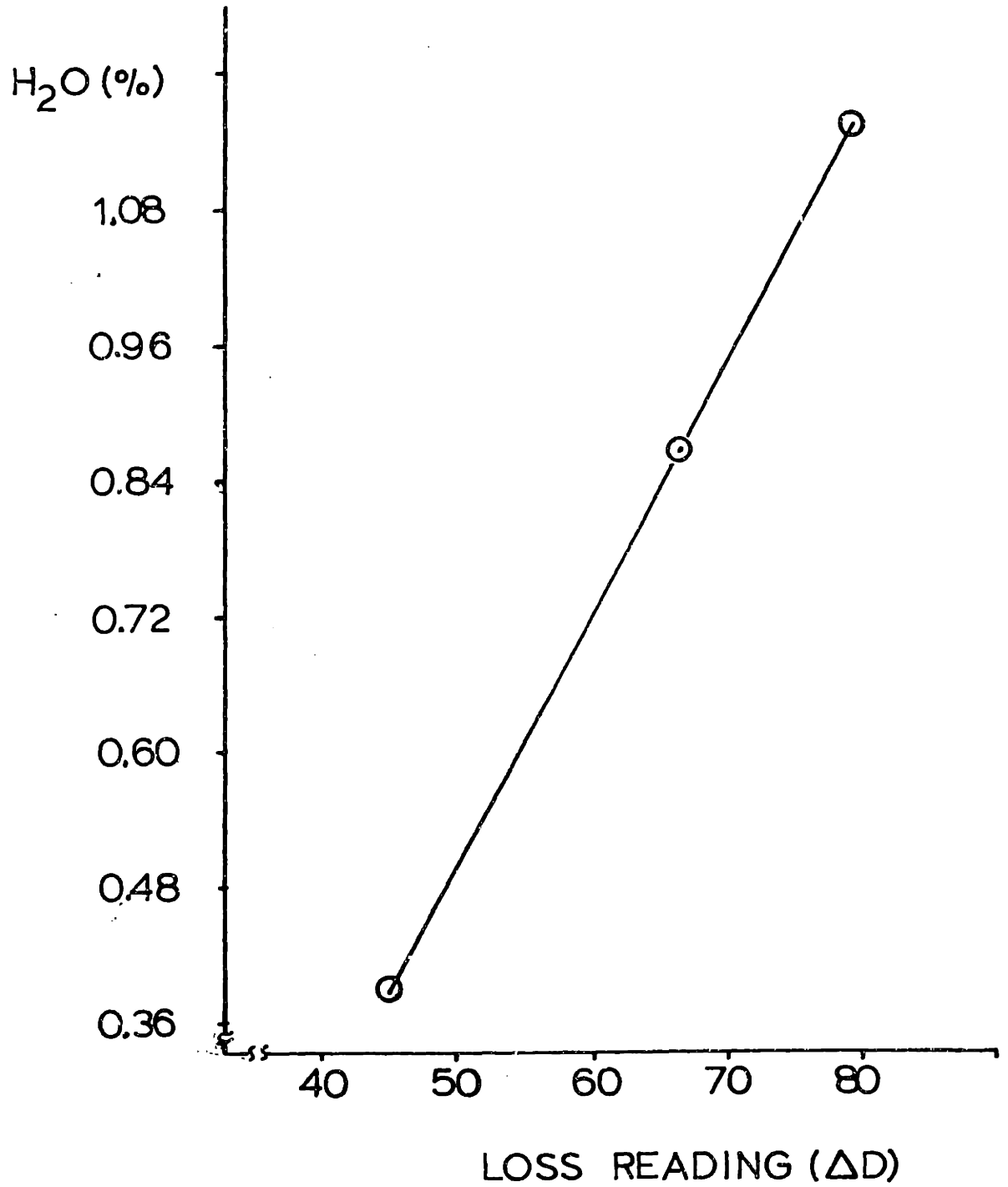

FIGURE 20: Loss reading vs. moisture content at 23°C

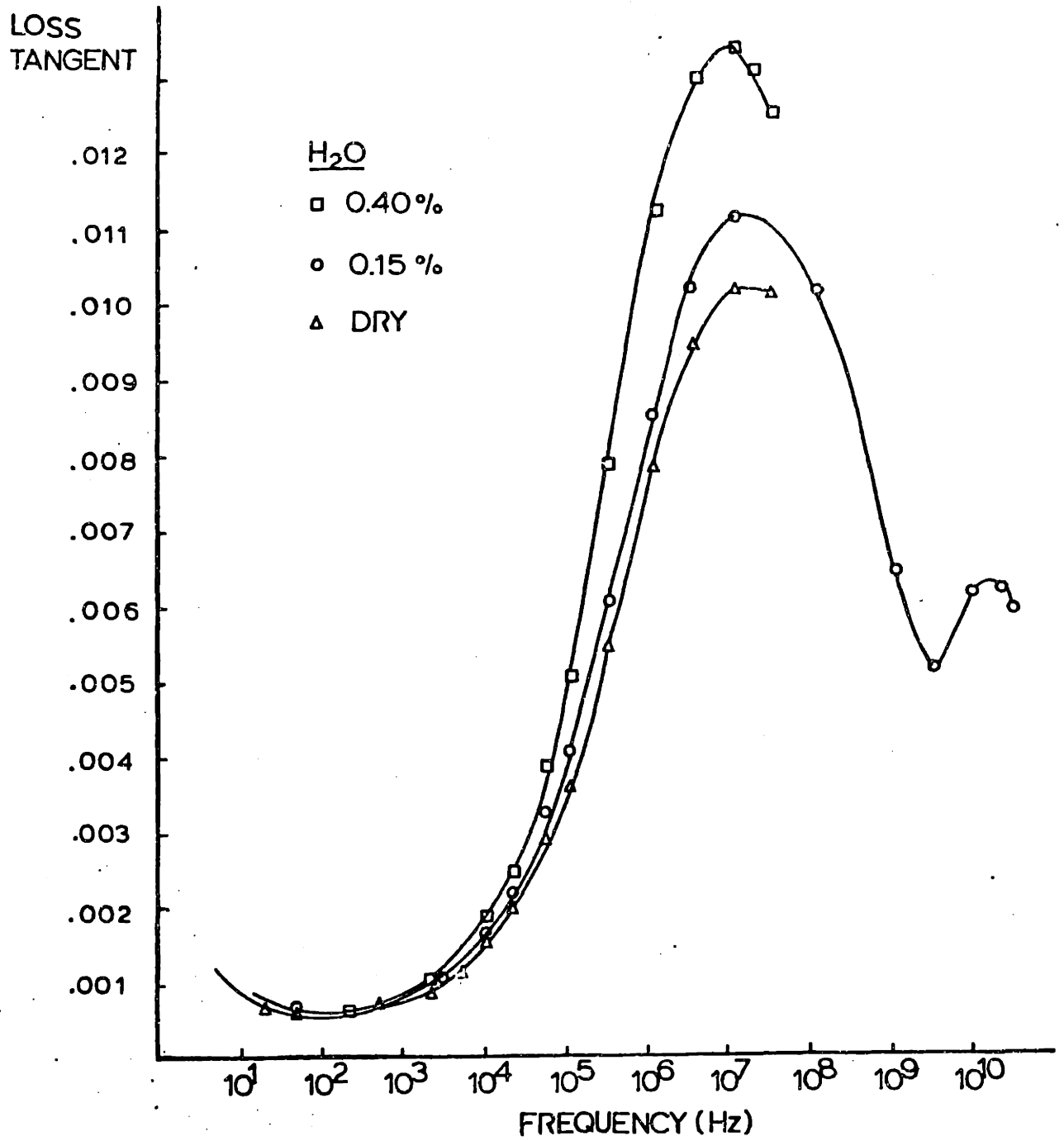
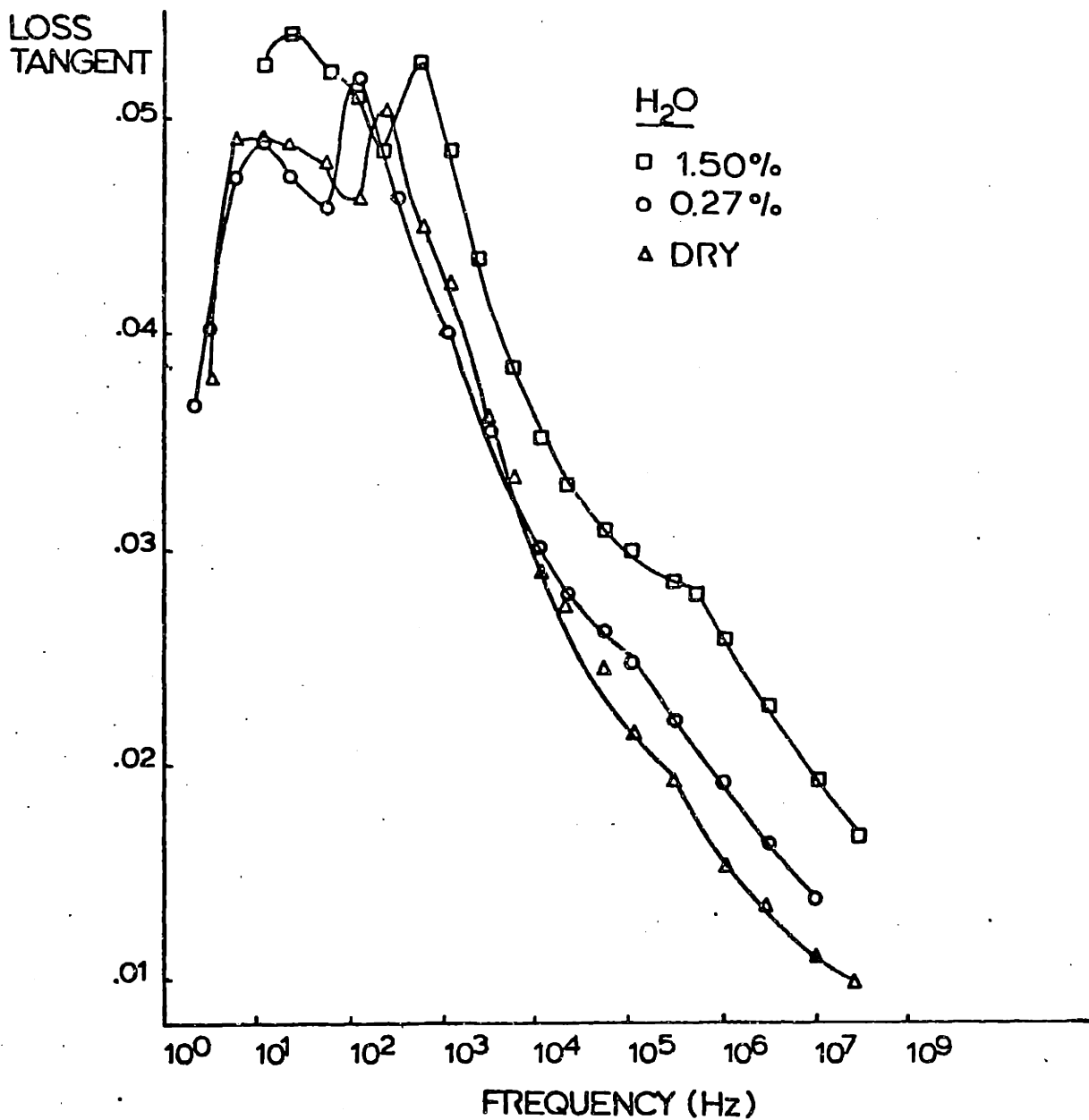

FIGURE 21 : LOSS TANGENT vs. FREQUENCY
for POLYCARBONATE at 23°C



**FIGURE 22 : LOSS TANGENT vs. FREQUENCY
for PMMA at 23^oC**

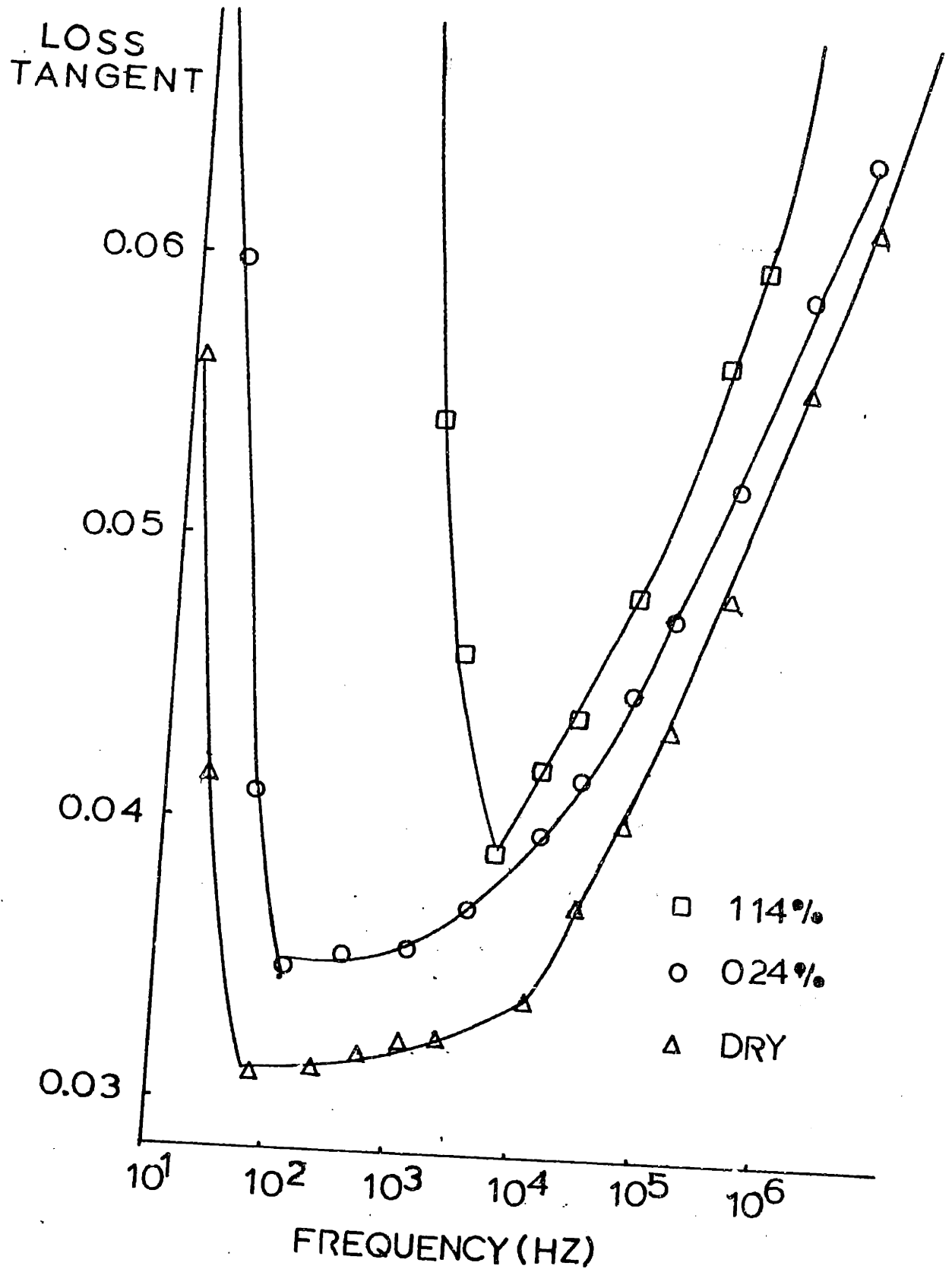

FIGURE 23: Loss tangent vs. frequency for polyurethane at 23°C

LOSS FACTOR

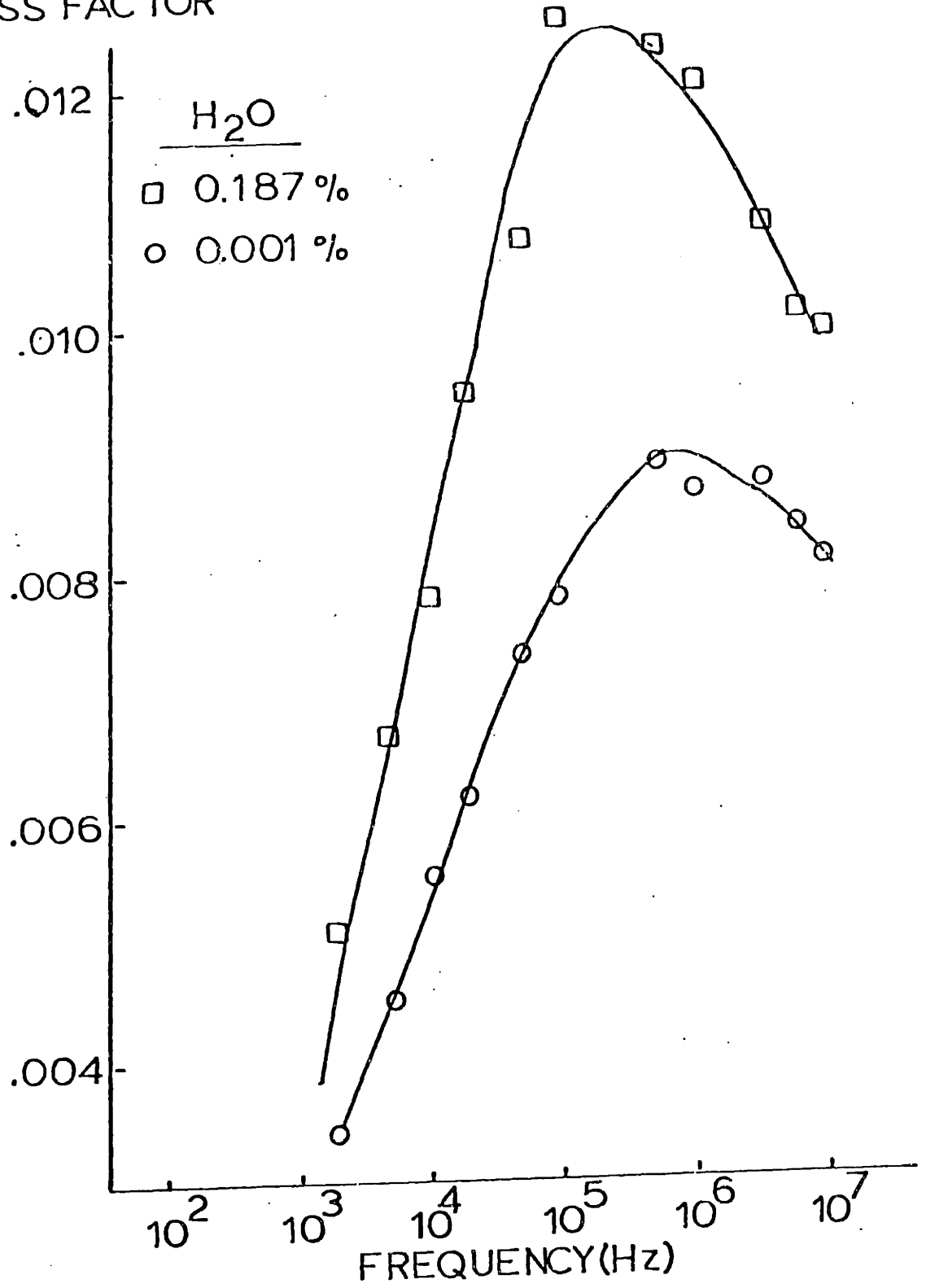

FIGURE 24: Loss factor vs. frequency for polyethylene terephthalate at 23°C

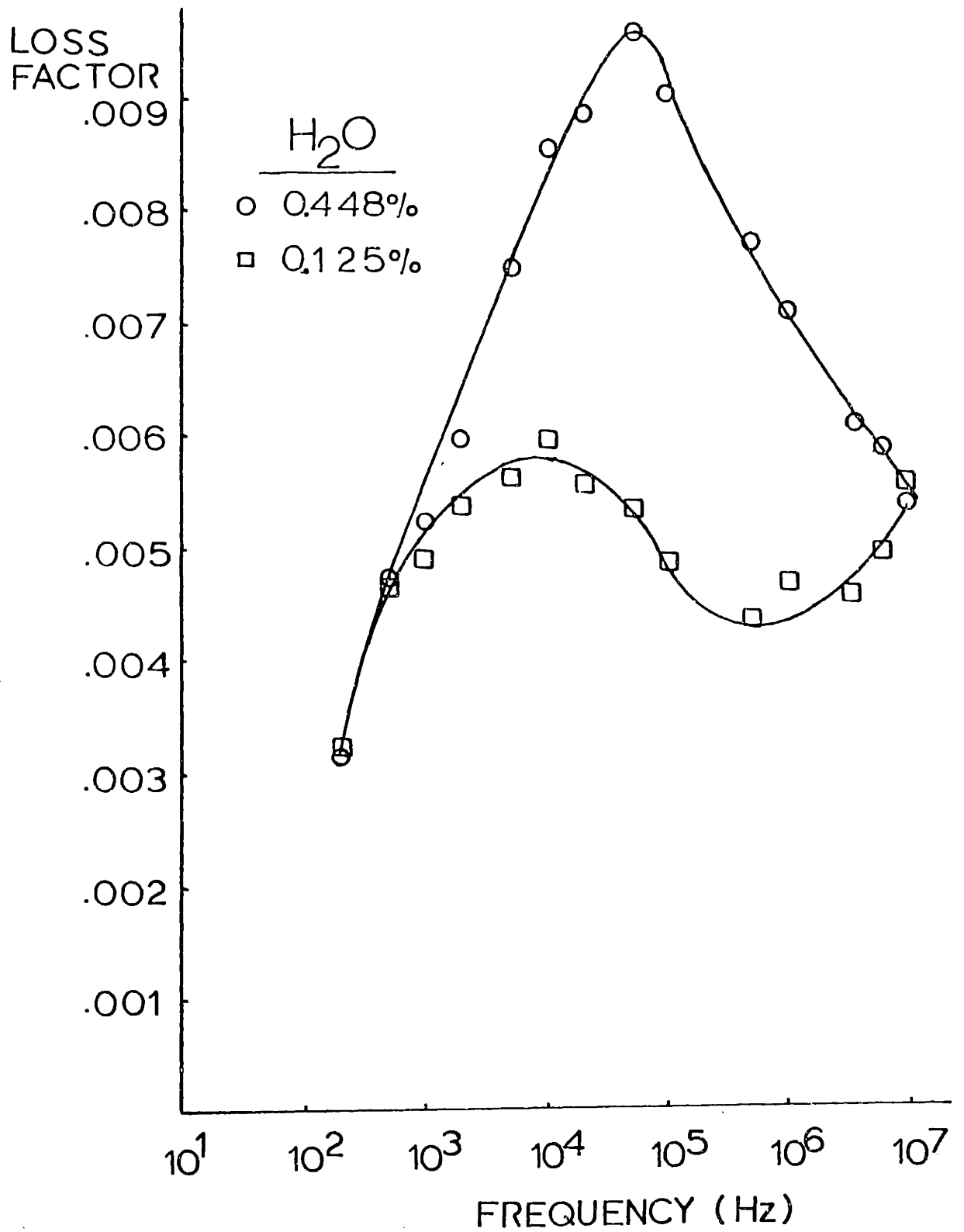

FIGURE 25: Loss factor vs. frequency for poly(amide-imide) at 23°C

III - C: Temperature Run

III - C - 1: Experimental Procedures

Temperature of the sample was controlled by controlling the temperature of the silicon oil bath. The controller, Haake (TP 41) was used. A mixer was used to have a uniform temperature distribution in the oil bath. To off-set the temperature rise due to the viscous heat generation by the mixer, cooling was required. The refrigerator (Forma Scientific Inc.) was used for the required cooling. A schematic diagram of the temperature experiment is shown in Figure 26.

At each temperature setting, the system was equilibrated for at least 30 min. before taking measurements. In most cases, the two thermocouple readings (one located at oil inlet, T.C. #1, and the other at oil outlet, T.C. #2) were the same except at high temperatures. When the two thermocouple readings were different, an average of the two readings was taken as the temperature of the sample.

The changes in the loss readings on the capacitance bridge [27] were measured at a fixed frequency of 20 KHz.

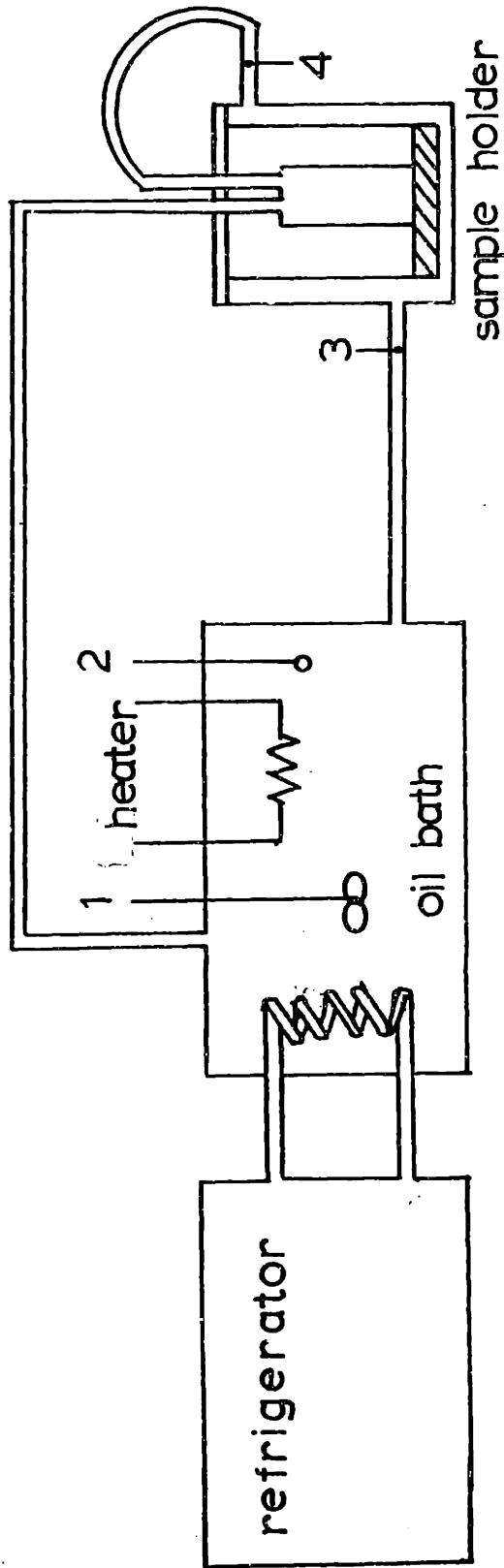

FIGURE 26: Schematic of the temperature experiment; 1) mixer,

2) temperature sensor, 3) thermocouple (T.C. #1),

4) thermocouple (T.C. #2)

III - C - 2: Sample Preparation

Granules of nylon 6/6 (Vydyne 21x) were conditioned to three different moisture levels by putting them into the constant humidity desiccators over a period of three months. Granules with P_2O_5 desiccant had the moisture content of 0.15% by weight; granules with LiCl desiccant had 0.90%; granules with CaCl₂ desiccant had 1.27%.

III - C - 3: Results

The change in the loss reading of the bridge vs. temperature of three different moisture level nylon 6/6 sample is shown in Figure 27. First, it shows that the process is thermally activated. Second, it shows that there are two different thermally activated mechanism, since the slope of the lines in Figure 27 changed. For the moisture of 0.90% by weight, the slope changed to a higher value than the others did. An obvious explanation for such a result was not possible without further investigation.

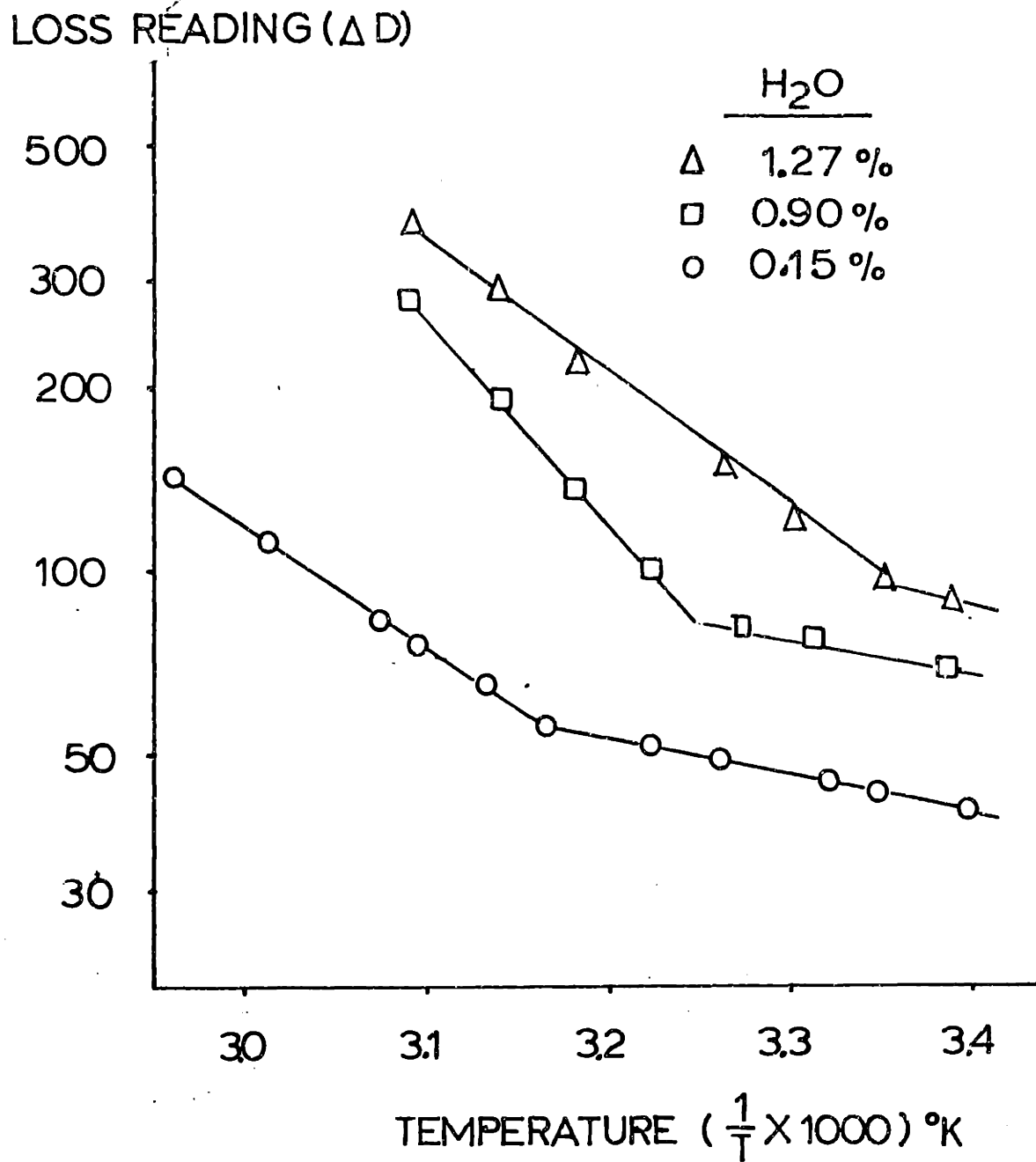

FIGURE 27: Loss reading vs. temperature for nylon 6/6 (Vydyne 21x) at 20K Hz.

III - D: Comparative Measurement

III - D - 1: Experimental Procedures

The type 1605-A impedance comparator made by General Radio Company is designed to measure and indicate on meters the magnitude and phase-angle differences between two external impedances. Since no bridge-balancing operation is necessary, the measurement may be made rapidly. The comparative type of measurement is particularly suitable for industrial application, since an absolute measurement is not necessary for processing.

The impedance comparator with the adjustable standard box and the sample holder is shown in Figure 28. The adjustable standard box is nothing but a variable capacitor and a variable resistor in parallel. When an unknown sample, connected to one leg of the bridge, to be standardized, the capacitor and the resistor in the standard box are adjusted until the phase angle difference and the impedance difference meters can be brought to a null position. The phase angle difference meter is used to determine whether an unknown sample has a higher or lower moisture content than the standardized sample.

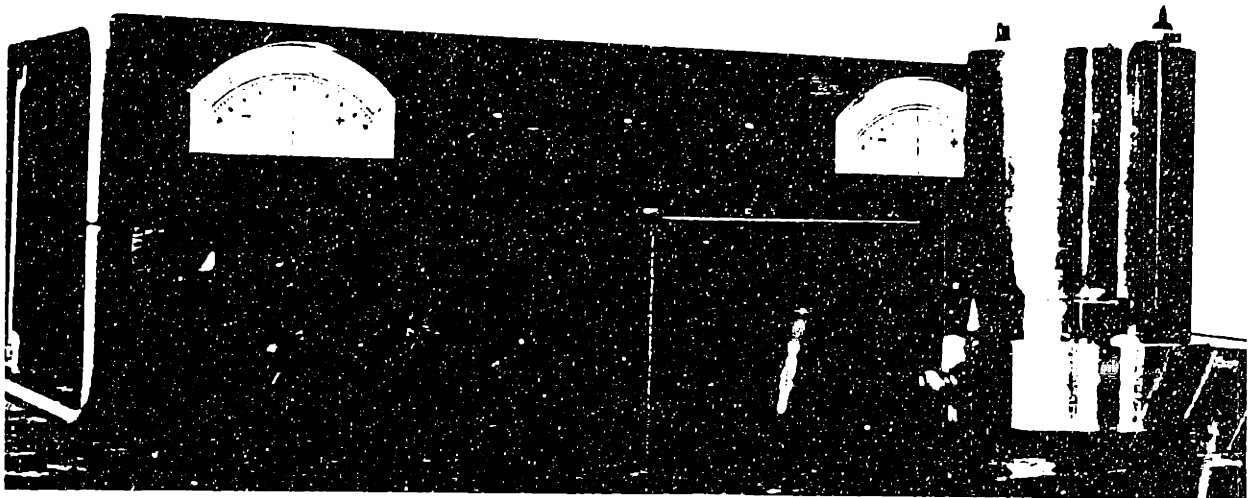

**FIGURE 28 : Impedance comparator
(G.R. type 1605-A) with
the adjustable standard
box and the sample holder**

III - D - 2: Sample Preparation

Three moisture levels (0.6%, 0.2%, and 0.1% by weight) of nylon 6/6 (Vydyne 21x) have been prepared by AMP Inc. 412 grams of granular nylon 6/6 were used in the testing.

III - D - 3: Results

The resistor and the capacitor in the standard box have been adjusted so that the phase angle difference and the impedance difference readings were zero when a 0.2% moisture level sample was used as a standard sample. The 0.6% moisture level sample had +0.0007 radiants (rad.) and 0.1% moisture level sample had -0.00045 rad. reading.

Since the phase angle difference meter of the impedance comparator is sensitive upto $2 \cdot 10^{-5}$ rad., an accurate and fast comparative measurement is possible.

A nonlinear response was observed. A sensitivity of 0.005% by weight is estimated if the response of the phase angle difference is linear between 0.1% and 0.2% moisture levels. On the other hand, a sensitivity of 0.01% is estimated assuming the linear response the linear response between 0.2% and 0.6% moisture levels.

As the sample size increases, the limitation due to noise in the measurement system becomes smaller. And, in the 3-terminal measurement, noise problems are virtually eliminated. Hence, more sensitive measurement can be achieved if the sample size increases of 3-terminal measurement is made. Also, more sensitive measurement

can be made if a more sensitive phase angle difference meter is used. For example, the type 1605-AH(General Radio) has a 3-to-1 better sensitivity than the type 1605-A (G.R.).

III - E: Conduction Mechanism

III - E - 1: Experimental Procedures

In polymers both electrons and ions contribute to the total conductivity, however it is likely that one type of conductivity will predominate depending on the internal structure, the temperature, the applied voltages, ect.

Seanor [30] has suggested that conduction in nylon 6/6 involves the transport of both protons and electrons at temperatures above 120°C , whereas at lower temperatures it is by transport of electrons. This experiment is carried out to investigate Seanor's suggestion about the conduction charge carrier at elevated temperatures.

A circuit diagram of the experiment is shown in Figure 29. One of the silver electrodes was heated electrically, and the temperature of the sample was raised to 135°C by conduction through the electrode. After the sample reached a thermal equilibrium at 135°C , 3000 volts were applied across the sample.

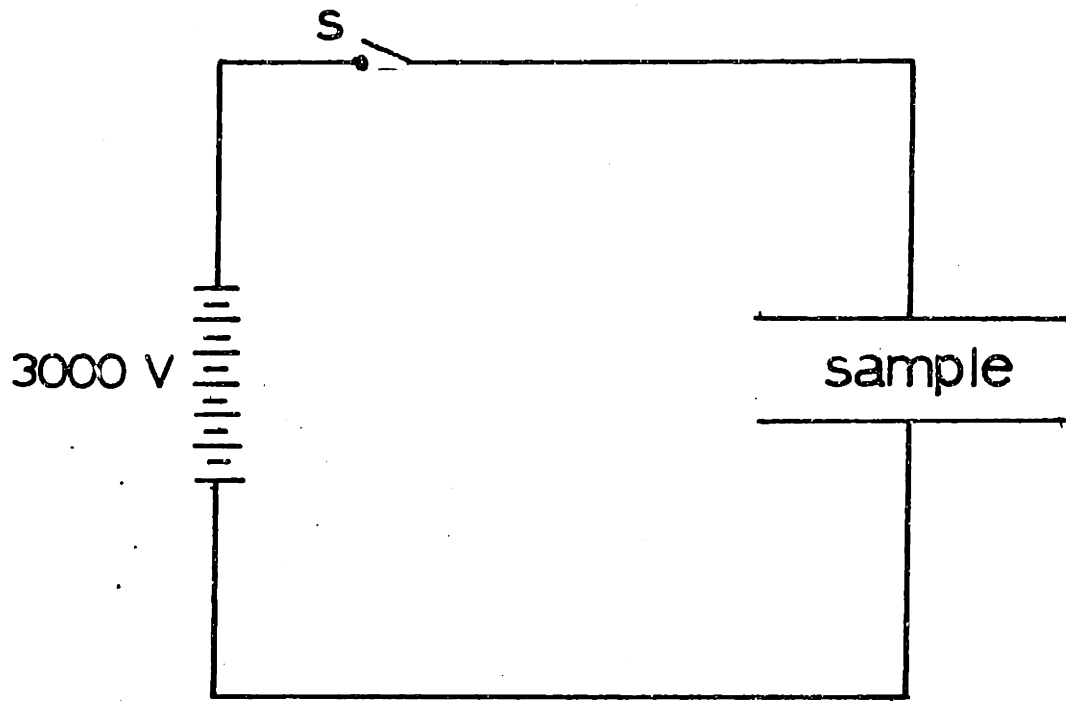

FIGURE 29: Circuit diagram of the conduction experiment

III - E - 2: Sample Preparation

The sample was a nylon 6/6 (Vydyne 21x) disk of 2 in. in diameter and 1/8 in. in thickness. The moisture level of the sample was about 3.5% by weight, determined by the Meeco moisture analyzer. The sample was in the desiccator with NaCl desiccant over a period of three months.

III - E - 3: Results

When 3000 volts were applied across the sample, the current of 0.5 mA was observed for the whole duration of the experiment. The experiment was terminated after one hour.

Some brown dots were seen only on the positive electrode and the side of the sample which was in contact with the positive electrode. The S.E.M. photograph of the dots is shown in Figure 30. The dots are some compounds of silver. A photograph of the X-ray Energy Spectrum of a dot, indicating that the dots consist of silver, is shown in Figure 31.

Interpretation of the brown dots is as follows: The absorbed water dissociated into the ions of H^+ and OH^- . These ions moved toward the opposite polarity electrode under the electrostatic force field. When hydroxyl ions (OH^-) reached the silver electrode, an oxidation reaction occurred;

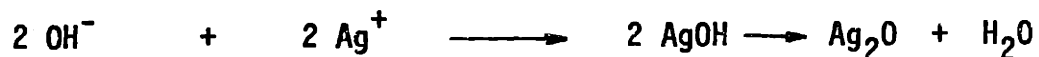

At the other electrode, hydrogen gas might have been evolved as Seanor [30] observed;

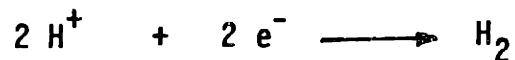

Thus, it is possible that the hydrogen gas Seanor had observed is not from the protons of amide groups, but instead it is from an electrolysis of water.

This dissociation of water and the transport of the dissociated ions by an electric field brings about the possibility of drying of polymer by an electric field.

A simple calculation of the water removal rate is presented:

- o assumption: charge carriers are H^+ & OH^-
- o number of H_2O dissociated = $0.5 \times (0.5 \cdot 10^{-3} \frac{\text{coulomb}}{\text{sec}})$
 $\times 6.281 \cdot 10^{18} \frac{\text{molecules}}{\text{coulomb}} = 1.57 \cdot 10^{15} \frac{\text{molecules}}{\text{sec}}$
- o water removal rate = $1.57 \cdot 10^{15} \frac{\text{molecules}}{\text{sec}} \times \frac{18}{6.02 \cdot 10^{23}}$
 $= 1.7 \cdot 10^{-4} \text{ g/hr.}$

A surprisingly low water removal rate is calculated. Nevertheless, further investigation would be helpful in finding the feasibility of drying by an electric field. Osaki et al. [34], also, reported the possibility that the absorbed water can be removed by a d.c. field.

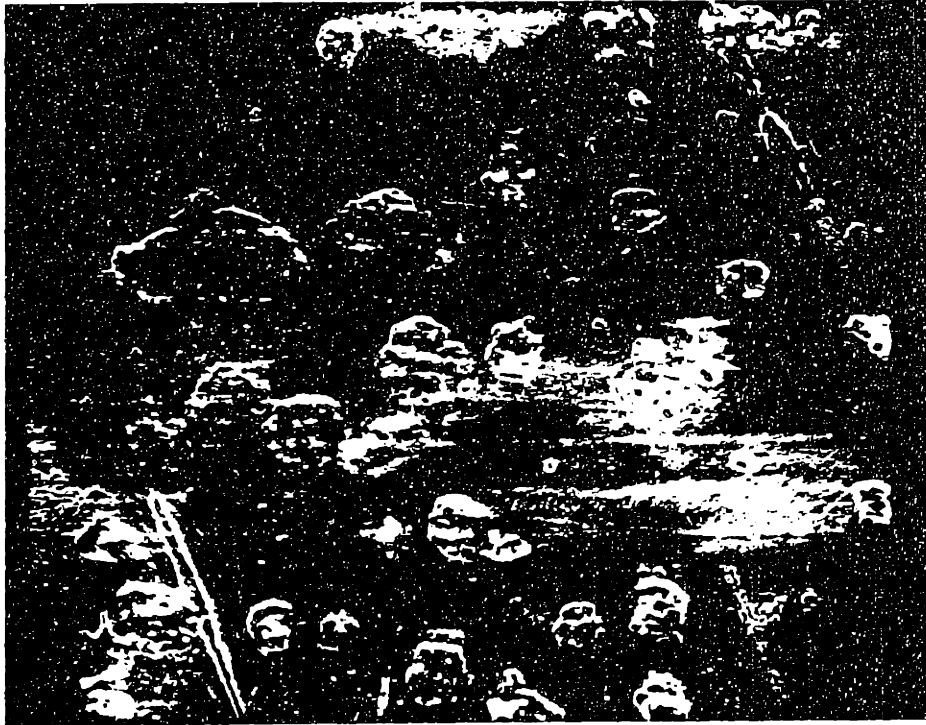
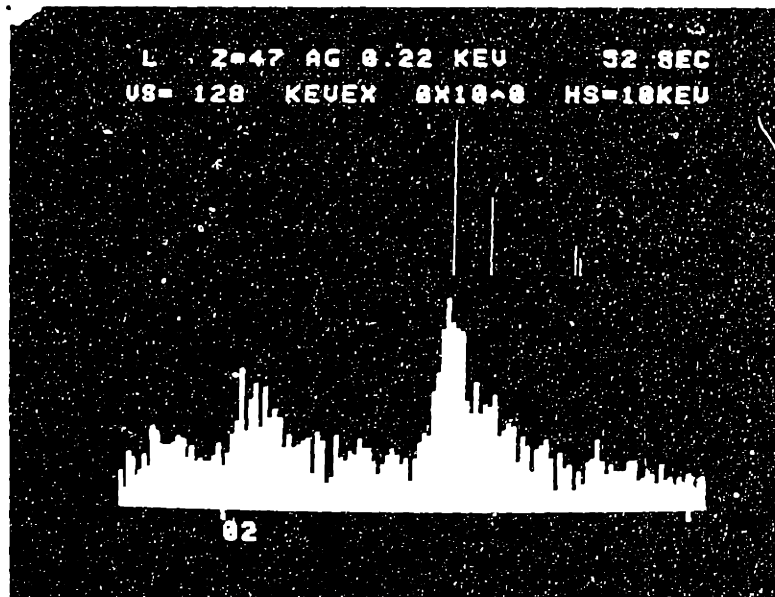

FIGURE 30: S.E.M photograph of the brown dots
(X 1000)



(coating Au)

FIGURE 31: Photograph of X-ray Energy Spectrum
of a brown dot

CHAPTER IV

DISCUSSION

D.C. experiments indicated that it is possible to measure the moisture level in polymers. There are about three orders of magnitude difference in the amplitude of the current ($t = 20$ sec.) through nylon 6/6 between moisture levels of 3.45% and .26%. This difference in current level is due to the change in the volume resistivity as a function of moisture content. Measurements at low levels of current due to background electrical noise resulting from harmonics in the power line.

This method would be useful in the nondestructive evaluation of the moisture content of finished products, liquid monomers, or some relatively highly conductive polymers such as polyurethane. Measurements on polymer granules were not reproducible due to residual charges and conduction along the surface of the granules.

The A.C. method is free of the residual surface charge problem of the D.C. method. For most accurate determination of the moisture level it is necessary to determine the most moisture-sensitive frequency. However, this frequency does not have to be located precisely, because the moisture related relaxation shows a broad absorption spectrum, unlike the sharp spectrum resulting from atomic absorption.

The moisture-sensitive frequency for nylon 6/6 is around 10^4 Hz, in agreement with other studies [21,22]. Since the loss maximum dis-

appeared for dry nylon 6/6 [21], the mechanism is a water-polymer complex relaxation not found in the dry state.

The loss maximum of nylon 6/6 (Vydyne 21) shifts to a higher frequency as the moisture content increased. This indicates that water provides a plasticizing action. The difference between Vydyne 21x and Vydyne 21 is that the former has a lubricant whereas the latter is pure nylon 6/6. The lubricant did not affect the moisture-sensitive relaxation, as evidenced by the fact that Vydyne 21x does not have a pronounced difference in the loss factor at around 10^4 Hz. On the other hand the loss factor of nylon 6/6 (J120 FR), which is glass filled with fire retardants, increased as the glass fibers and fire retardants loading, except at the moisture-sensitive frequency.

Thus, it may be concluded that the relaxation was due only to water-polymer complex, and not to any of the fillers or additives (the lubricants, the glass fibers, or the fire retardants). Additional experimental results will be useful in determining the effect of minute quantities of additives on the sensitivity of the A.C. measurement sensitivity. If significant side effects were found, then calibration for each type of nylon 6/6 will be required.

Such properties and morphology of polymers as crystallinity, degree of orientation, type of processing technique used, etc. may also affect the sensitivity of the moisture measurement. Further study on the same type of sample from different resin suppliers might be useful in determining the effects of sample's history and properties on the moisture measurement sensitivity.

The sensitivity of comparative measurement depends on how precisely the transformer in the bridge could be balanced. When the ratio arms of the impedance comparator is balanced to be equal within one part in 10^6 (General Radio Type 1605-A Spec.), a detector sensitivity of $2 \cdot 10^{-5}$ radians in phase difference can be attained from the comparative measurement.

Polymer such as polycarbonate, poly (amide-imide), and polyethylene terephthalate showed the moisture associated relaxation peaks whereas PMMA and polyurethane did not. Common factors relating the group of polymers exhibiting a moisture-sensitive relaxation have not been investigated.

An accurate, fast, and on-line measurement of the moisture level in polymers is possible if a comparative measurement technique is used. The exact value of the moisture content is not required during injection molding or extrusion; instead an indication of whether the moisture level is lower or higher than a level desired would be sufficient and perhaps more useful. By calibrating two standard values, one for the minimum and the other for the maximum acceptable moisture levels, a continuous monitoring of the polymer resins within a desired moisture level is possible. Whenever the moisture level of the resins is within the acceptable range, the dryer can be turned off. In so doing, overheating can be eliminated leading to a substantial savings in energy cost.

The loss factor reading increases exponentially as temperature

increases, indicating that the process is thermally activated. With a decreasing moisture level, the change in the slope of the lines shown in Figure 26 occurs at higher temperatures. Although it has been speculated that this is due to the change in the glass transition temperature with moisture, further investigation is needed to elucidate its causes. In on-line monitoring of the moisture level a microprocessor can be used to compensate the changes in the reading due to the temperature change.

The conduction in nylon with a substantial amount of absorbed water involves the transport of either electrons or dissociated water ions depending on the temperature. At elevated temperatures, for instance above 90°C, ions of dissociated water are the dominant charge carriers as indicated by the oxidation of the silver electrode (Sec. III-E-3). Olf et al.[31] studied the chain mobilization and the mobility of water in nylon 6/6. They concluded that the temperature at which the chain segmental motion in the crystalline regions begin to occur is about 90°C. Hence, below 90°C, ions cannot pass through the crystalline region due to chain stiffness.

At temperatures below 90°C, nylon can be considered as a wide band gap semi-conductor, with the handing-on type electron charge transfer. In this case, absorbed water molecules may act as electron donor impurities. A possible handing-on [20] type of electron transfer is in the next page:

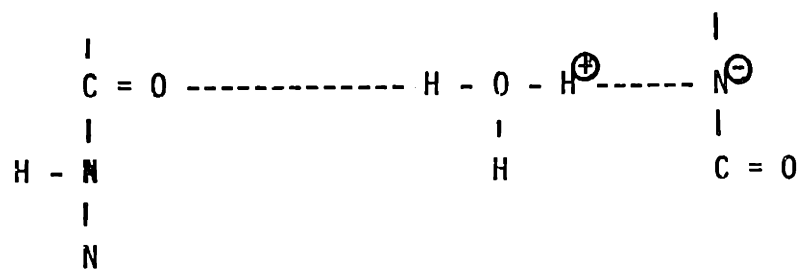
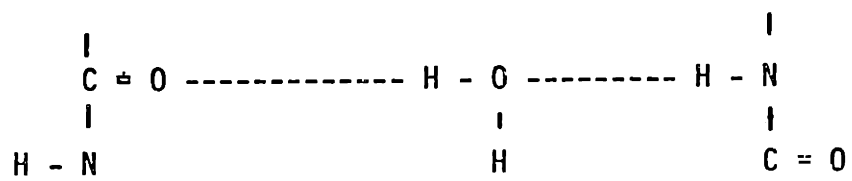

CHAPTER V

CONCLUSIONS

Based on the research reported in this thesis, the following conclusions can be drawn:

- 1). The dielectric loss factor is very sensitive to the moisture level in polymers regardless of whether or not the water molecules are bound to polymers.
- 2). The moisture-sensitive frequencies for the following polymers have been found:

polyamide	$\sim 10^4$ Hz
poly (amide-imide)	$\sim 10^4$ Hz
polyethylene terephthalate	$\sim 10^4$ Hz
polycarbonate	$\sim 10^7$ Hz
polymethylmethacrylate	$\sim 10^5$ Hz
Thermoplastic Polyurethane	$\sim 10^3$ Hz

- 3). An accurate, fast, and on-line measurement of the moisture level in polymer is possible if a comparative measurement unit such as the impedance comparator (General Radio Type 1605 - A) is used

- 4). The amplitude of decaying current, when a D.C. voltage is applied across the bulk of a polymer sample, is very sensitive to the material's moisture content. Therefore, it can also be used to monitor the moisture level.

REFERENCES

1. McCrum, N.G., Read, B.E., and Williams, G., Anelasticity and Dielectric Effects in Polymeric Solids, New York, Wiley, Ch. 12, 1967
2. VALOX[®] resin information brochure.
3. General Electric product information brochure for 'Lexan for extrusion'
4. Kellum, G.E. and Barger, J.D., "Determination of water in Nylon with Karl Fischer Reagent using Fluorinated Alcohols as Solvents," Analytical chemistry, Vol. 42, No. 12, Oct. pp. 1428, 1970
5. "Standard methods of chemical analysis" 6th Ed., Van Nostrand, Princeton, N.J. Ch. 21
6. DuPont Instruments, Product Bulletin for 902 Moisture Evolution Analyzer.
7. Grill, P.S., "Determination of Moisture in Nylon," DuPont Instruments, Applications Brief SMA 3.
8. Shaw, T.M., Elskens R.H., and Lundin R.E., "NMR of water on Fibrous Materials," J. Textile Inst. Trans. 51: T562, 1960
9. Shaw, T.M., and Elskens R.H. "Techniques for Nuclear Magnetic Resonance Measurements on Granular Hygroscopic Materials," J. Appl. physics, Vol. 26, No. 3 pp. 313, 1955.
10. Slonim, I. Ya, Lyubimov, A.N. The NMR of Polymers, Plenum Press, New York, 1970, pp. 305.
11. Powles, J.G. and Kail, J.A.E., "Nuclear Resonance and Dielectric Relaxation in Crystals of some long-chain secondary alcohols," Trans. Faraday Soc., Vol. 55, pp. 1996, 1959.
12. Botsoc, R.J. "Nondestructive Testing of plastics with Microwaves," Part 1 and Part 2. Plastic Design and Processing. [Reprinted from Nov. and Dec. 1968 Issues, Lake Publishing Corp. (Libertyville, Ill.).]
13. Brochure on MCS 401, Moisture Control Systems, Inc. Vincennes, Indiana.

14. Trifan and Terenzi, "Extents of Hydrogen Bonding in Polyamide and Polyurethanes," J. Polymer Sci., Vol. 28, pp. 443, 1958
15. Nylon Plastic, Ed. Kohan M.I., John Wiley & Sons, PP. 393, 1973
16. Ibid, pp. 366
17. Modern Plastics Encyclopedia, McGraw Hill, New York, 1978-1979.
18. Von Hippel, A.R., Ed., Dielectric Materials and Applications, M.I.T. Press., Cambridge, Massachusetts, 1954
19. Papir, Y.S., Kapur, S., Rogers, C.E., and Baer, E., "Effect of Orientation, Anisotropy, and Water on the relaxation Behavior of Nylon 6 from 4.2 to 300° K," J. Polymer Science: Part A-2, Vol. 10, pp.1305, 1972
20. Eley, D.D. and Leslie R.B., "Kinetics of Adsorption of Water Vapor and Electrical Conduction in Bovine Plasma Albumin," Trans. Faraday Soc., Vol.66, pp.1002, 1962
21. Curtis, A.J., "Dielectric Properties of Polyamides: Polyhexamethylene Adipamide and Polyhexamethylene Sebacamide," J. Research of the National Bureau of Standards -A Physics and Chemistry, Vol. 65A, No. 3, May-June 1961
22. Rushton, E. and Russell, G. "The Dielectric Properties of Nylon," Brit. Elect. and Allied Indust. Research Assoc. Report, L/T 355, 1959
23. Baker, W.O. and Yager, W.A., "The Relation of Dielectric Properties to Structure of Crystalline Polymers. II. Linear Polyamides," J. Am. Chem. Soc., Vol. 64, pp. 2171, 1942
24. Baker, W.O., Fuller, C.S., Pape, N.R., "Effects of Heat, Solvents and Hydrogen-bonding Agents on the Crystallinity of Cellulose Esters," J. Am. Chem. Soc., Vol. 64, pp. 776, 1942
25. Boyd, R.H., "Dielectric Loss in 66 Nylon," J. Chemical Physics, Vol. 30, No. 5, pp. 1276, 1959
26. A. Von Hippel and Co-workers, "The Dielectric Relaxation Spectra of Water, Ice, and Aqueous Solutions and Their Interpretation," Lab. for Insulation Research Tech. Report, No. 6, M.I.T., Cambridge, Massachusetts, 1969

27. Charles, R.E., Rao, K.V. and W.B. Westphal, "A Capacitance Bridge Assembly for Dielectric Measurements from 1 hz to 40 Mhz," Lab. for Insulation Research Tech. Report, No. 201, M.I.T., Cambridge, Massachusetts, 1966.
28. W.B. Westphal "Dielectric Constant and Loss Measurements on High-Temperature Materials," Lab. for Insulation Research Tech. Report, No. 182, M.I.T., Cambridge, Massachusetts, 1963.
29. Von Hippel, A.R. ed., Dielectric and Waves, J. Willey and Sons, New york, 1954, pp. 96
30. Seanor, D.A. J. Polymer Science: Part A-2 ,Vol 6, pp.463, 1968.
31. H.G. Olf and A. Perterlin, J. Polymer Science : Part A-2, Vol. 9 pp.2033, 1971.
32. Golling, V.E. Zeit Schrift Fuel Angewandte physik, Vol. 14, pp.717, 1962.
33. A.Von Hippel and L.G.Wesson, "Polystyrene Plastics as High Frequency Dielectrics", Industrial and Engineering chemistry, Vol.38 , pp.1121, Nov. 1946.
34. S.Osaki, S.Uemura, and Y.Isida, J. Polymer Science : Part A-2, Vol. 9, pp. 2099, 1971.

APPENDIX A1

Hydrolysis Mechanism of Polyamide

Polyamide, otherwise known as nylon, is one of the well known synthetic thermoplastics. Nylon possesses good resistance to impact and fatigue, has a low coefficient of friction, and has excellent abrasion resistance.

Nylon is normally processed by extrusion or injection molding. While nylon is being processed, it can undergo degradation by hydrolysis. Hydrolytic degradation of nylon is a chemical reaction in which the nylon reacts with ions of water (H^+ and OH^-) to break the bond of the nylon chain. This hydrolytic reaction lowers molecular weight because the long chain of nylon gets shorter due to the scission. The technological importance of hydrolytic degradation of nylon lies in the deterioration of tensile properties. It is therefore desirable to understand the mechanism of the hydrolysis of nylon.

The mechanism of hydrolysis can be viewed as a depolymerization process of polyamide. Depolymerization is simply the reverse reaction of polymerization. Polymerization, also known as condensation, is a forward reaction in which amide and water are produced by the chemical reaction between amine and carboxylic acid. Depolymerization is a reverse reaction in which amide and water react to produce amine and carboxylic acid.

The reaction of an amine with a carboxylic acid to form an amide can be represented as follows:

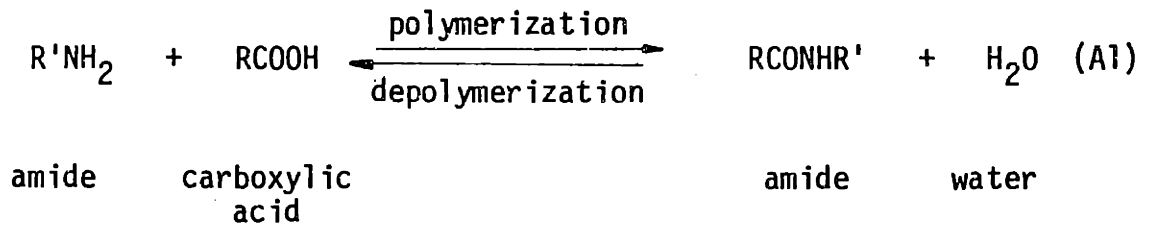

Note that water is a by-product in the polymerization of nylon. Since water is part of the product, depolymerization can be viewed as hydrolysis. In equation (A1), arrows point both ways; one indicates the direction of polymerization and the other that of depolymerization. The reaction continues as long as the equilibrium concentrations of products and reactants are not reached. For example, if the concentration of water is greater than the equilibrium concentration of water, nylon depolymerizes to lower the concentration of water until the equilibrium condition is satisfied. However, when one pours some water over a nylon block there is no chemical reaction at all. The reason is that depolymerization is an endothermic reaction. In other words water and nylon need energy to react with each other. In extrusion or injection molding processes, enough thermal energy is supplied so that nylon hydrolyzes with the excess water.

30

APPENDIX A2

Dielectric Data of Nylon 6/6

The following table contains the dielectric data of nylon 6/6. The table gives the dielectric constant, the loss factor, the loss tangent, the conductivity, and the conductance. The environment in which the samples were conditioned and their moisture levels are listed in Table 4.

sample A: Vydyne 21, 0.1% H₂O

FREQ., HZ	DIE. CONST	LOSS FACTOR	LOSS TANGENT	COND., MHO/CM	CONDUCTANCE	N
10000.000	4.8053	0.073812	0.015360	0.41063E-08	0.25113E-06	1
5000.000	4.8404	0.077926	0.016099	0.21676E-08	0.13256E-06	2
2000.000	4.8903	0.079897	0.016338	0.88896E-09	0.54366E-07	3
1000.000	4.9272	0.079070	0.016048	0.43988E-09	0.26902E-07	4
500.000	4.9605	0.074886	0.015097	0.20830E-09	0.12739E-07	5
200.000	5.0029	0.065916	0.013175	0.73340E-10	0.44852E-08	6
100.000	5.0325	0.058503	0.011625	0.32546E-10	0.19904E-08	7
50.000	4.8737	0.051277	0.010521	0.14263E-10	0.87228E-09	8
20.000	4.9752	0.042128	0.008468	0.46873E-11	0.28666E-09	9
10.000	5.1027	0.034347	0.006731	0.19108E-11	0.11686E-09	10
5.000	5.1174	0.030551	0.005970	0.84979E-12	0.51970E-10	11
2.000	5.1710	0.033641	0.006506	0.93573E-12	0.57226E-10	12
1.000	5.1802	0.025714	0.004964	0.28610E-12	0.17497E-10	13
0.500	5.1950	0.023147	0.004456	0.12877E-12	0.78752E-11	14
0.200	5.1913	0.022001	0.004238	0.61196E-13	0.37426E-11	15
0.100	5.2098	0.024445	0.004692	0.27198E-13	0.16634E-11	16
0.050	5.2246	0.029392	0.005626	0.16351E-13	0.10000E-11	17
0.020	5.2412	0.033467	0.006385	0.93090E-14	0.56931E-12	18
0.010	5.2615	0.042197	0.008020	0.46950E-14	0.28713E-12	19
	5.2855	0.052383	0.009911	0.29141E-14	0.17822E-12	20

sample B: Vydne 21, 0.23% H₂O

FREQ., HZ	DIE. CONST	LOSS FACTOR	LOSS TANGENT	COND., MHO/CM	CONDUCTANCE	N
10000.000	4.7735	0.086660	0.018154	0.48210E-08	0.29623E-06	1
5000.000	4.8176	0.092396	0.019179	0.25701E-08	0.15792E-06	2
2000.000	4.8746	0.095793	0.019651	0.10658E-08	0.65491E-07	3
1000.000	4.9178	0.093313	0.018975	0.51912E-09	0.31898E-07	4
500.000	4.9592	0.087024	0.017548	0.24206E-09	0.14874E-07	5
200.000	5.0125	0.076443	0.015251	0.85053E-10	0.52262E-08	6
100.000	5.0419	0.067309	0.013350	0.37445E-10	0.23009E-08	7
50.000	5.0694	0.059359	0.011709	0.16511E-10	0.10146E-08	8
20.000	5.1025	0.048471	0.009499	0.53930E-11	0.33138E-09	9
10.000	5.1227	0.040896	0.007983	0.22751E-11	0.13980E-09	10
5.000	5.1375	0.035082	0.006829	0.97583E-12	0.59961E-10	11
50.000	5.2027	0.035157	0.006757	0.97791E-12	0.60089E-10	12
20.000	5.2165	0.028996	0.005559	0.32262E-12	0.19824E-10	13
10.000	5.2294	0.025286	0.004835	0.14067E-12	0.86436E-11	14
5.000	5.2275	0.024446	0.004676	0.67998E-13	0.41782E-11	15
2.000	5.2551	0.024475	0.004657	0.27231E-13	0.16733E-11	16
1.000	5.2624	0.031281	0.005944	0.17402E-13	0.10693E-11	17
0.500	5.2762	0.033599	0.006368	0.93457E-14	0.57426E-12	18
0.200	5.2992	0.046343	0.008745	0.51563E-14	0.31683E-12	19
0.100	5.3231	0.052136	0.009794	0.29004E-14	0.17822E-12	20

sample C: Vydine 21, 0.48% H₂O

FREQ., HZ	DIE. CONST	LOSS FACTOR	LOSS TANGENT	COND., MHO/CM	CONDUCTANCE	N
10000.000	4.8711	0.103746	0.021298	0.57715E-08	0.35409E-06	1
50000.000	4.9245	0.108652	0.022064	0.30222E-08	0.18542E-06	2
20000.000	4.9908	0.108730	0.021786	0.12098E-08	0.74220E-07	3
10000.000	5.0386	0.103144	0.020471	0.57380E-09	0.35204E-07	4
5000.000	5.0828	0.094405	0.018573	0.26259E-09	0.16111E-07	5
2000.000	5.1380	0.081947	0.015949	0.91177E-10	0.55938E-08	6
1000.000	5.1712	0.071911	0.013906	0.40005E-10	0.24544E-08	7
500.000	5.1988	0.063610	0.012236	0.17694E-10	0.10855E-08	8
200.000	5.2338	0.052110	0.009957	0.57980E-11	0.35571E-09	9
100.000	5.2558	0.044611	0.008488	0.24818E-11	0.15226E-09	10
50.000	5.2687	0.039525	0.007502	0.10994E-11	0.67451E-10	11
50.000	5.3258	0.041918	0.007871	0.11660E-11	0.71534E-10	12
20.000	5.3368	0.032586	0.006106	0.36256E-12	0.22243E-10	13
10.000	5.3497	0.030109	0.005628	0.16750E-12	0.10276E-10	14
5.000	5.3773	0.029937	0.005567	0.83273E-13	0.51089E-11	15
2.000	5.4749	0.033941	0.006199	0.37763E-13	0.23168E-11	16
1.000	5.4473	0.039162	0.007189	0.21787E-13	0.13366E-11	17
0.500	5.3368	0.046415	0.008697	0.12911E-13	0.79208E-12	18
0.200	5.3497	0.059469	0.011116	0.66167E-14	0.40594E-12	19
0.100	5.3773	0.072523	0.013487	0.40345E-14	0.24752E-12	20

sample D: Vydne 21x, 0.13% H₂O

FREQ., HZ	DIE.CONST	LOSS FACTOR	LOSS TANGENT	COND., MHO/CM	CONDUCTANCE	N
10000.000	4.8150	0.071248	0.014797	0.39636E-08	0.24173E-06	1
50000.000	4.8483	0.076419	0.015762	0.21257E-08	0.12964E-06	2
20000.000	4.8992	0.078305	0.015983	0.87124E-09	0.53135E-07	3
10000.000	4.9344	0.076661	0.015536	0.42648E-09	0.26010E-07	4
5000.000	4.9705	0.071571	0.014399	0.19908E-09	0.12141E-07	5
2000.000	5.0076	0.061891	0.012360	0.68862E-10	0.41997E-08	6
1000.000	5.0354	0.054345	0.010793	0.30233E-10	0.18438E-08	7
500.000	5.0585	0.047362	0.009363	0.13174E-10	0.80345E-09	8
200.000	5.0835	0.038215	0.007517	0.42519E-11	0.25931E-09	9
100.000	5.1002	0.033855	0.006638	0.18834E-11	0.11486E-09	10
50.000	5.1131	0.029458	0.005761	0.81939E-12	0.49973E-10	11
20.000	5.1724	0.023179	0.004481	0.25790E-12	0.15729E-10	12
10.000	5.1863	0.017324	0.003340	0.96375E-13	0.58776E-11	13
5.000	5.1835	0.019260	0.003716	0.53574E-13	0.32673E-11	14
2.000	5.1965	0.022033	0.004240	0.24514E-13	0.14950E-11	15
1.000	5.2085	0.025097	0.004818	0.13962E-13	0.85149E-12	16
0.500	5.2242	0.030350	0.005809	0.84419E-14	0.51485E-12	17
0.200	5.2428	0.040855	0.007793	0.45457E-14	0.27723E-12	18

sample E: Vydne 21x, 0.43% H₂O

FREQ., HZ	DIE.CONST	LOSS FACTOR	LOSS TANGENT	COND., MHO/CM	CONDUCTANCE	N
10000.000	4.8124	0.105574	0.021938	0.58732E-08	0.36004E-06	1
5000.000	4.8676	0.110837	0.022770	0.30830E-08	0.18899E-06	2
2000.000	4.9358	0.111128	0.022515	0.12364E-08	0.75797E-07	3
1000.000	4.9837	0.105635	0.021196	0.58766E-09	0.36025E-07	4
500.000	4.9855	0.096761	0.019408	0.26915E-09	0.16499E-07	5
200.000	5.0298	0.084489	0.016798	0.94005E-10	0.57627E-08	6
100.000	5.0887	0.074650	0.014670	0.41529E-10	0.25458E-08	7
50.000	5.1256	0.065870	0.012851	0.18322E-10	0.11232E-08	8
20.000	5.1514	0.054918	0.010661	0.61103E-11	0.37457E-09	9
10.000	5.1891	0.047424	0.009139	0.26382E-11	0.16173E-09	10
5.000	5.2103	0.039264	0.007536	0.10922E-11	0.66952E-10	11
5.000	5.2251	0.043926	0.008407	0.12218E-11	0.74900E-10	12
2.000	5.2822	0.034795	0.006587	0.38714E-12	0.23733E-10	13
1.000	5.3061	0.032949	0.006210	0.18330E-12	0.11237E-10	14
5.000	5.3172	0.033097	0.006225	0.92062E-13	0.56436E-11	15
2.000	5.3301	0.037016	0.006945	0.41185E-13	0.25248E-11	16
1.000	5.3411	0.042678	0.007990	0.23742E-13	0.14554E-11	17
0.500	5.3669	0.049355	0.009196	0.13728E-13	0.84158E-12	18
0.200	5.3854	0.066774	0.012399	0.74295E-14	0.45545E-12	19
0.100	5.4204	0.075484	0.013926	0.41993E-14	0.25743E-12	20

sample F: Vydne 21x, 0.56% H₂O

FREQ., HZ	DIE. CONST	LOSS FACTOR	LQSS TANGENT	COND., MHO/CM	CONDUCTANCE	N
10000.000	4.8750	0.127731	0.026201	0.71059E-08	0.43561E-06	1
50000.000	4.9395	0.134446	0.027219	0.37397E-08	0.22925E-06	2
20000.000	5.0224	0.135858	0.027050	0.15116E-08	0.92664E-07	3
10000.000	5.0814	0.131091	0.025798	0.72928E-09	0.44706E-07	4
5000.000	5.1422	0.123520	0.024021	0.34358E-09	0.21062E-07	5
2000.000	5.2122	0.111300	0.021354	0.12384E-09	0.75914E-08	6
1000.000	5.2564	0.101159	0.019245	0.56276E-10	0.34498E-08	7
500.000	5.2969	0.092492	0.017462	0.25727E-10	0.15771E-08	8
200.000	5.3503	0.080917	0.015124	0.90031E-11	0.55191E-09	9
100.000	5.3817	0.073120	0.013587	0.40678E-11	0.24936E-09	10
50.000	5.4646	0.067121	0.012283	0.18670E-11	0.11445E-09	11
20.000	5.4876	0.059630	0.010866	0.66346E-12	0.40671E-10	12
10.000	5.5217	0.060265	0.010914	0.33527E-12	0.20552E-10	13
5.000	5.5530	0.066194	0.011920	0.18412E-12	0.11287E-10	14
2.000	5.5770	0.074904	0.013431	0.83340E-13	0.51089E-11	15
1.000	5.6138	0.085646	0.015256	0.47646E-13	0.29208E-11	16
0.500	5.6672	0.104517	0.018442	0.29072E-13	0.17822E-11	17
0.200	5.7317	0.134275	0.023427	0.14940E-13	0.91584E-12	18
0.100	5.8017	0.162581	0.028023	0.90446E-14	0.55446E-12	19

sample G: J 120 FR, 0.13% H₂O.

FREQ., HZ	DIE. CONST	LOSS FACTOR	LOSS TANGENT	COND., MHO/CM	CONDUCTANCE	N
100000.000	4.9615	0.046694	0.009411	0.25977E-08	0.16557E-06	1
50000.000	4.9810	0.049468	0.009931	0.13760E-08	0.87703E-07	2
20000.000	5.0120	0.048690	0.009715	0.54174E-09	0.34530E-07	3
10000.000	5.0359	0.046108	0.009156	0.25650E-09	0.16349E-07	4
5000.000	5.0554	0.041702	0.008249	0.11600E-09	0.73935E-08	5
2000.000	5.0767	0.035233	0.006940	0.39201E-10	0.24986E-08	6
1000.000	5.0909	0.031097	0.006108	0.17299E-10	0.11027E-08	7
500.000	5.1050	0.027222	0.005332	0.75721E-11	0.48264E-09	8
200.000	5.1210	0.022524	0.004398	0.25061E-11	0.15974E-09	9
100.000	5.1316	0.018318	0.003570	0.10191E-11	0.64955E-10	10
50.000	5.1405	0.019733	0.003839	0.54890E-12	0.34986E-10	11
50.000	5.2043	0.024208	0.004652	0.67337E-12	0.42920E-10	12
20.000	5.2096	0.018110	0.003476	0.20150E-12	0.12844E-10	13
10.000	5.2007	0.014572	0.002802	0.81064E-13	0.51669E-11	14
5.000	5.2149	0.018485	0.003545	0.51416E-13	0.32772E-11	15
2.000	5.2326	0.020802	0.003975	0.23145E-13	0.14752E-11	16
1.000	5.2450	0.025968	0.004951	0.14446E-13	0.92079E-12	17
0.500	5.2574	0.030156	0.005736	0.83882E-14	0.53465E-12	18
0.200	5.2787	0.040488	0.007670	0.45048E-14	0.28713E-12	19
0.100	5.3017	0.053053	0.010007	0.29514E-14	0.18812E-12	20

sample H: J 120 FR, 0.31% H₂O

FREQ.,HZ	DIE.CONST	LOSS FACTOR	LOSS TANGENT	COND., MHO/CM	CONDUCTANCE	N
100000.000	5.0142	0.076358	0.015228	0.42479E-08	0.27184E-06	1
50000.000	5.0495	0.079965	0.015836	0.22243E-08	0.14234E-06	2
20000.000	5.1024	0.078170	0.015320	0.86975E-09	0.55658E-07	3
10000.000	5.1368	0.073896	0.014385	0.41109E-09	0.26307E-07	4
5000.000	5.1677	0.068320	0.013220	0.19004E-09	0.12161E-07	5
2000.000	5.2030	0.060622	0.011651	0.67450E-10	0.43163E-08	6
1000.000	5.2295	0.056076	0.010723	0.31196E-10	0.19963E-08	7
500.000	5.2560	0.052176	0.009927	0.14513E-10	0.92875E-09	8
200.000	5.2807	0.048634	0.009210	0.54112E-11	0.34628E-09	9
100.000	5.3018	0.046269	0.008727	0.25740E-11	0.16472E-09	10
50.000	5.3230	0.046307	0.008699	0.12881E-11	0.82428E-10	11
50.000	5.3866	0.049171	0.009128	0.13677E-11	0.87524E-10	12
20.000	5.4016	0.048103	0.008905	0.53520E-12	0.34249E-10	13
10.000	5.4298	0.052336	0.009639	0.29115E-12	0.18632E-10	14
5.000	5.4572	0.063410	0.011620	0.17638E-12	0.11287E-10	15
2.000	5.4766	0.081071	0.014803	0.90202E-13	0.57723E-11	16
1.000	5.5189	0.100121	0.018141	0.55699E-13	0.35644E-11	17
0.500	5.5719	0.125708	0.022561	0.34967E-13	0.22376E-11	18
0.200	5.6566	0.171041	0.030237	0.19030E-13	0.12178E-11	19
0.100	5.7343	0.219711	0.038316	0.12223E-13	0.78218E-12	20

sample I: J 120 FR, 0.52% H₂O

FREQ., HZ	DIB. CONST	LOSS FACTOR	LOSS TANGENT	COND., MHO/CM	CONDUCTANCE	N
10000.000	5.1210	0.101648	0.019849	0.56548E-08	0.35843E-06	1
5000.000	5.1709	0.107101	0.020712	0.29791E-08	0.18883E-06	2
2000.000	5.2368	0.109571	0.020923	0.12191E-08	0.77274E-07	3
1000.000	5.2850	0.107748	0.020388	0.59942E-09	0.37995E-07	4
500.000	5.3331	0.104880	0.019666	0.29173E-09	0.18492E-07	5
200.000	5.3936	0.100835	0.018695	0.11219E-09	0.71113E-08	6
100.000	5.4328	0.098374	0.018107	0.54727E-10	0.34689E-08	7
50.000	5.4774	0.097264	0.017757	0.27055E-10	0.17149E-08	8
20.000	5.5308	0.098981	0.017896	0.11013E-10	0.69806E-09	9
10.000	5.5754	0.102425	0.018371	0.56980E-11	0.36117E-09	10
5.000	5.6146	0.108967	0.019408	0.30310E-11	0.19212E-09	11
2.000	5.6680	0.103579	0.018274	0.28811E-11	0.18262E-09	12
1.000	5.7340	0.125368	0.021864	0.13949E-11	0.88415E-10	13
0.500	5.7696	0.134000	0.023225	0.74546E-12	0.47251E-10	14
0.200	5.8391	0.162291	0.027794	0.45142E-12	0.28614E-10	15
0.100	5.9389	0.213393	0.035931	0.23743E-12	0.15049E-10	16
0.050	6.0351	0.259722	0.043035	0.14449E-12	0.91584E-11	17
0.020	6.1278	0.325144	0.053061	0.90441E-13	0.57327E-11	18
0.010	6.3719	0.447845	0.070285	0.49829E-13	0.31584E-11	19
	6.5376	0.575601	0.088045	0.32022E-13	0.20297E-11	20

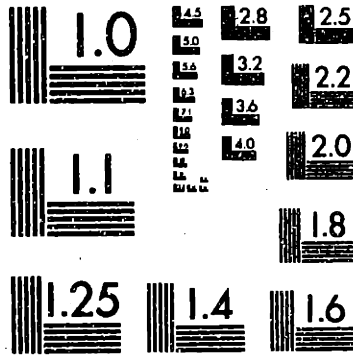

MICROCOPY RESOLUTION TEST CHART
NATIONAL BUREAU OF STANDARDS-1963-A



