

AN AIR-LEVITATED FESTOONING SYSTEM
FOR THE HUMAN MOBILITY LABORATORY

by

DANIEL LEE WOLK

SUBMITTED IN PARTIAL FULFILLMENT
OF THE REQUIREMENTS FOR THE
DEGREE OF

BACHELOR OF SCIENCE

at the

MASSACHUSETTS INSTITUTE OF TECHNOLOGY

June, 1977

Signature of Author. *[Handwritten Signature]*

Department of Mechanical
Engineering

May 12, 1977

Certified by. *[Handwritten Signature]*

Thesis Supervisor

Accepted by *[Handwritten Signature]*

Chairman, Departmental Committee on
Thesis



AN AIR-LEVITATED FESTOONING SYSTEM
FOR THE HUMAN MOBILITY LABORATORY

by

DANIEL LEE WOLK

Submitted to the Department of Mechanical Engineering
on May 12, 1977 in partial fulfillment of the requirements
for the Degree of Bachelor of Science.

ABSTRACT

In the Department's Human Mobility Laboratory is a myoelectrically-controlled, hydraulically-damped above-the-knee prosthesis. Its accompanying hydraulic modulator, which controls the leg's behavior, is connected to the electronics and hydraulic pump with 76 feet of cables and hydraulic lines. These currently hang from eight carts which travel on an overhead track. The carts are noisy, hard to move, and tend to jam. Replacement of this festooning system with one using air-levitated carts was investigated. A working prototype vehicle was designed, built, and tested. Problems were discovered in the design, and an experiment run to elucidate them. Design changes are proposed, and the suitability of the system for this application, its practicality, and its economy are discussed.

Thesis Supervisor: Woodie Claude Flowers, Ph.D.

Associate Professor of Mechanical
Engineering

Acknowledgements:

My sincere thanks go to: Prof. Woodie Flowers, my supervisor, for his ideas, support, and criticism; Prof. David Gordon Wilson for helping me find materials; Tom Schneider, my roommate, for his ideas; Peggy Garlick, of the Department Administration Office, for her advice; and finally to the staff of the Materials Processing Laboratory, the Student Machine Shop, and the Engineering Projects Lab for their interest and help in setting up my experiment.

CONTENTS

1. Abstract	page 2
2. Acknowledgements	3
3. Table of Contents	4
4. List of Figures	5
5. Introduction	6
6. Design	8
7. Testing	19
8. Results	21
9. Conclusions	25
10. Appendix	28
11. References	29

FIGURES

1. The Laboratory Setup	page 7
2. Vehicle Forces	9
3a. Exploded View of Vehicle	10
3b. Cutting of Inner Tube	10
4. Vehicle Body	12
5. Cable Hanger Bracket	13
6. Track Mounting	14
7. Photograph of vehicle	15
8. " " "	16
9. Photograph of vehicle & track	17
10. Photo of vehicle, track, and mounting	18
11. Air Flow Patterns	19
12. Vehicle Test Setup	20
13. Graph: Flow vs. ΔD	22
14. Graph: f vs. ΔD	23
15. Graph: f vs. torque	24
16. Modes of "bistable" vehicle behavior	25
17. Series & parallel hookup of air supply	26

Introduction:

Among the ongoing projects in the M.I.T. Mechanical Engineering Department's Human Mobility Laboratory, is experimentation with a myoelectrically-controlled, hydraulically-damped, above-the-knee prosthesis. During experimentation with the leg, the amputee test subject walks about in the room while the hydraulic modulator, which controls the prosthesis' behavior, is pushed along on a cart behind. The 76 feet of cables and hydraulic lines which connect the modulator to the pump and electronics pays-out accordingly, and currently hangs from eight little carts that run along an overhead track. Figure 1 is a sketch of the laboratory setup.

The problem is that the carts are noisy, hard to move, and tend to jam. Experimentation in the laboratory would be greatly facilitated if the present festooning system were replaced with a quiet, nearly frictionless one. The new system could include servo-driven transport of the cable bundle.

To this end, an air-levitated system has been designed in which the carts are supported by a cushion of air supplied by hoses. The concept behind this design, the "air-bearing" principle¹, is the same as that of the Stull-Ealing air track, a popular Physics demonstration. Compressed air, escaping through an orifice in the underside of a body, creates a cushion of air between it and any smooth, closely-fitting surface, practically eliminating friction between the two.

1 "Theory of the Air-Supported Puck", W.M. Whitney,
American Journal of Physics, Vol. 32, No. 4, April 1964

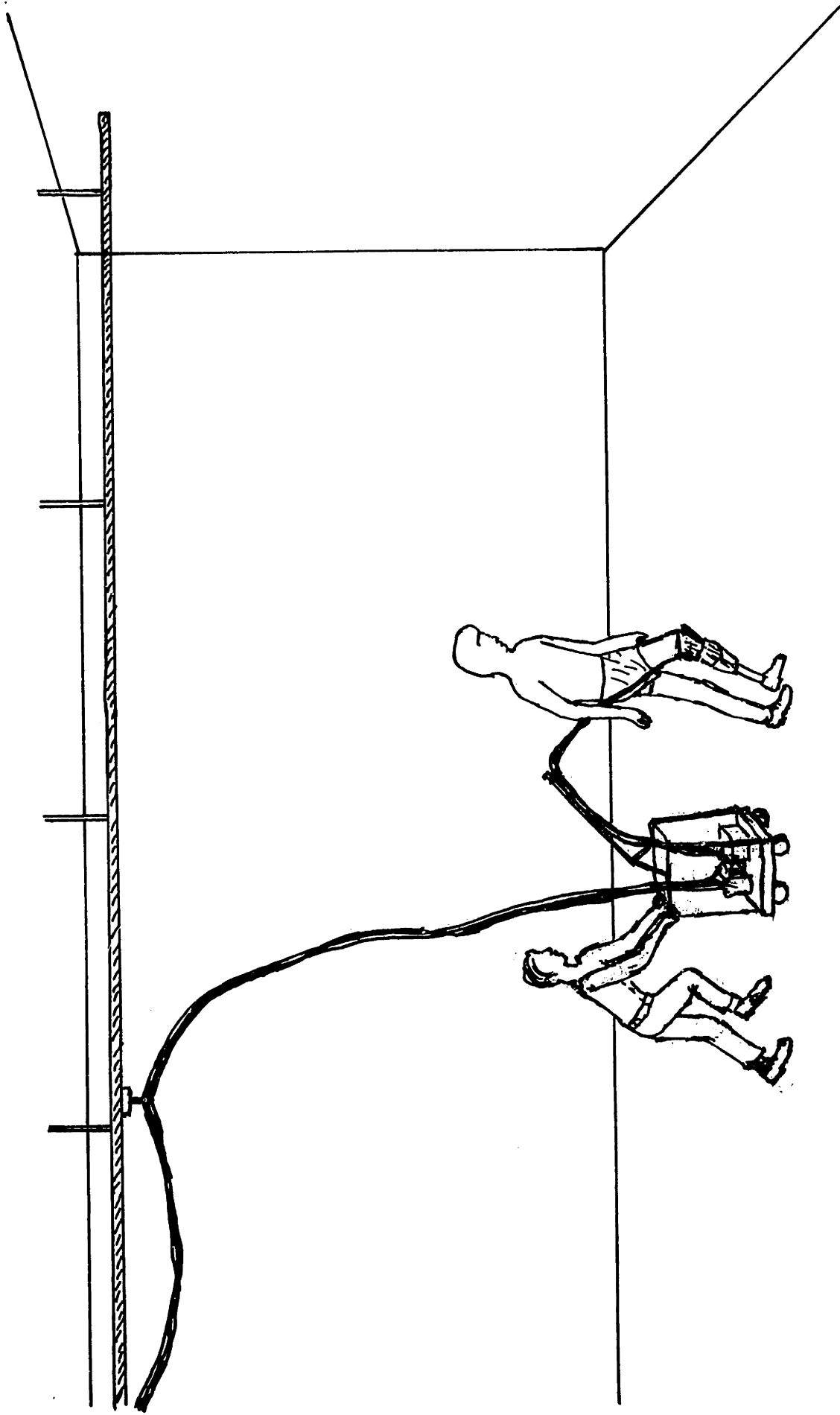

Figure 1 : The Laboratory Setup

The festooning system had to meet several criteria: Since experimentation in the prosthesis lab depends upon the continuous, reliable operation of the system, it had to be simple, with a minimum of moving parts. It also had to be quiet and low-friction, as these were the major objections to the existing equipment. With respect to this last requirement, the payload- and torque-handling capabilities had to be considered.

In the 76-foot bundle of cable connecting the pump and electronics to the hydraulic modulator are: two $\frac{1}{2}$ -inch hydraulic lines (out and return), and multi-strand electric cable (for telemetry). One foot of the electric cable weighs 140 grams, a foot of empty hydraulic tubing, 58 grams. The volume of one foot of hydraulic tubing is $12\text{in.} \times \pi \times (\frac{1}{2}\text{in.})^2 = 9.42 \text{ in}^3$. Assuming that hydraulic oil has a density of about 15gr./in^3 , one foot of each hydraulic line contains 140 grams of oil. Each of the eight carts holds up 8 feet of cables (the wall holds up the rest), so the payload of each cart is:

$$8\text{ft.} \times (140\text{gr.} + 2 \times (140\text{gr.} + 58\text{gr.})) = 4.27\text{kg.} = 9.4\text{lbs.}$$

In addition to this static load and transients in downward force, there are transient torques which the vehicle experiences and must counteract: roll, pitch, and yaw, as shown in Figure 2. at the top of the next page.

Thought, trial, and research resulted in the design shown in Figure 3a. It is, in essence, a rectangular frictionless puck bent around a cylinder. Air, escaping

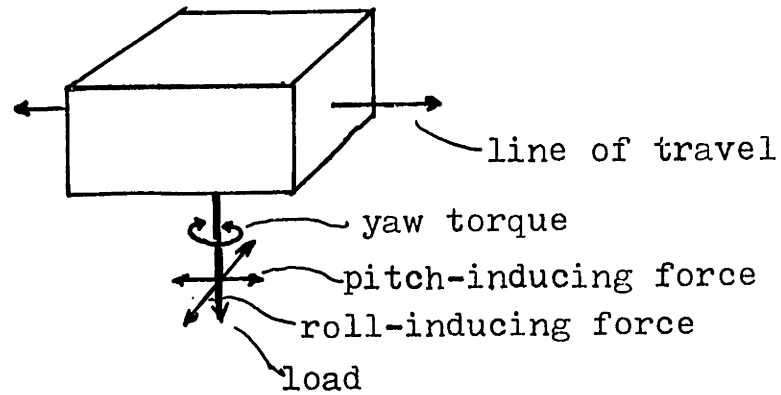
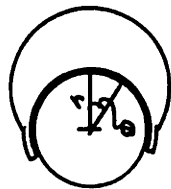

Figure 2: Vehicle Forces

through the two rows of holes in the inner surface, creates the cushion between the vehicle and the track, just as with a flat puck. We can see that:



$$L \int_{-100^{\circ}}^{+100^{\circ}} P_{avg} \cos \theta r d\theta = F$$

where P_{avg} is the average pressure in the gap, F is the payload plus the weight of the vehicle, and L is vehicle length.

Since the track is tubular, the vehicle can roll freely. Had there been only one row of holes down the center of the vehicle, when it rolled the holes would no longer be on the line of vertical force. Hence, to keep performance more uniform when the vehicle rolled, two rows of holes were placed symmetrically. The inner tube wraps around the track more than 180° (200°) to extend the cushion of air to the sides, helping to counteract yaw torque. With this arrangement, the the response to pitch- and yaw-disturbances is analogous to the disturbance-response of a flat puck; they will be damped-out.

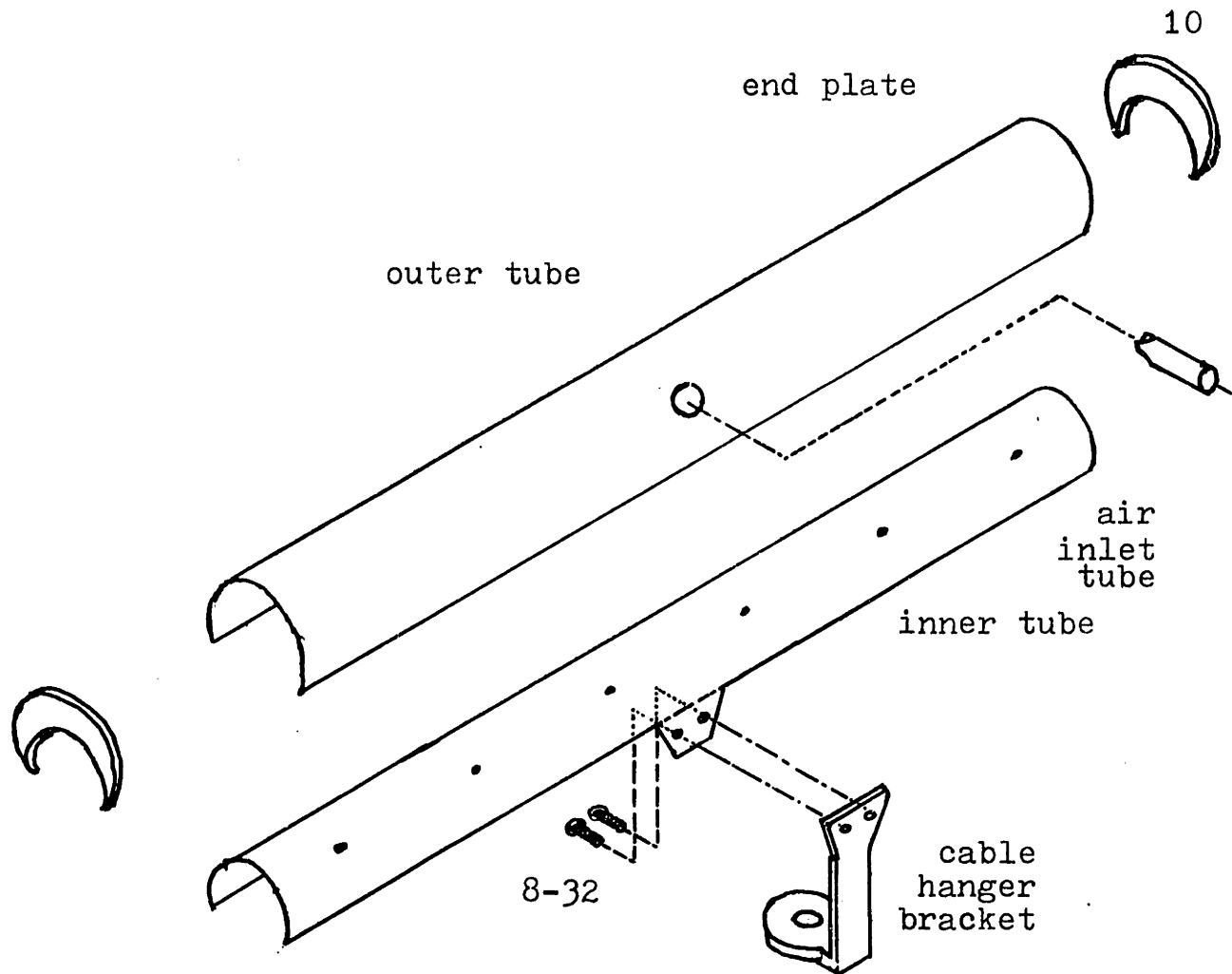

Figure 3a: Isometric, exploded view of vehicle
(1 cm. : 1 in.)



Figure 3b: Orthographic view of inner tube,
showing cutting lines (dotted)

(1 cm. : 1 in.)

Since air is supplied to each cart, rather than to the 11 entire track, the only sound from the system should be a soft hiss. The simplicity of the design speaks for itself, and since the gliders have flat, unadorned ends they will not interfere with each other.

Construction:

The vehicle, track, and their parts are shown in full-scale orthographic projection and in photographs, Figures 4 through 10.

To minimize vehicle weight and facilitate machining, aluminum was chosen as the material for all parts of the vehicle and track. The vehicle was constructed as follows: Using the ways of the milling machine for alignment, the outer tube was sliced from $1\frac{1}{2}$ " O.D. tubing. The end plates were cut from $1/8$ " plate and filed to match. The inner tube was left intact except for drilling the twelve $1/16$ " holes, and all four pieces were heliarc-welded together. Afterwards, a section was slit from the inner tube, as shown dotted in Figure 3b, and the side tab bent out, flattened, and drilled. A $3/8$ " hole was milled into the side of the outer tube. Where they would interfere, the welding fillets and burn-through were filed down and polished smooth. The cable hanger bracket was milled from $1/4$ "-thick aluminum channel.

Assuming an air cushion $1/16$ " thick, a track diameter of 1" was chosen. A gap this size would allow room for slight perturbations in the orientation of the vehicle, and enable it

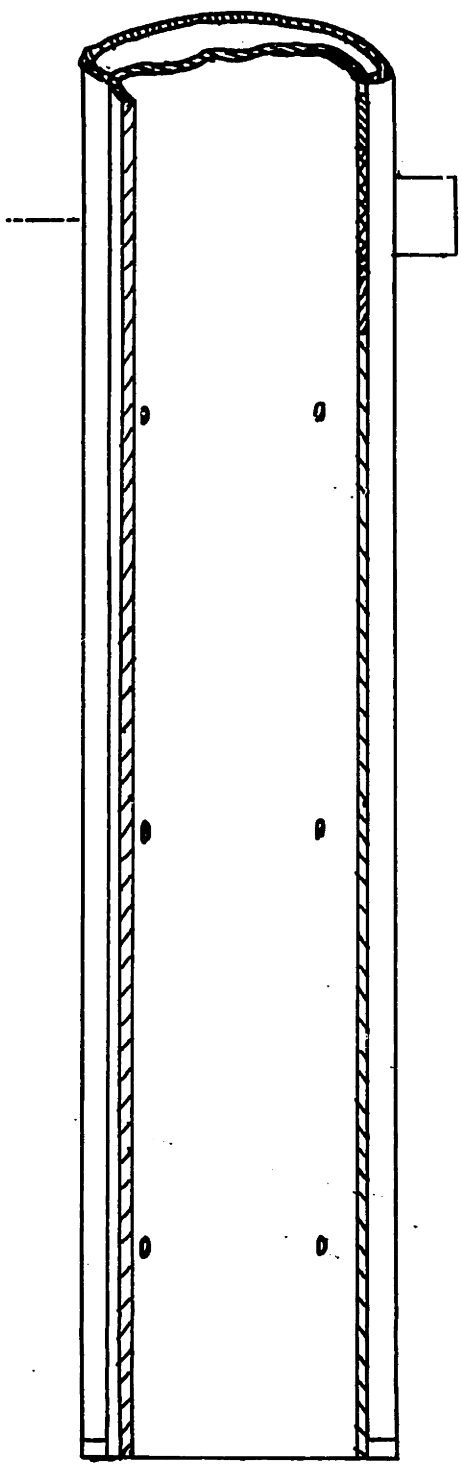
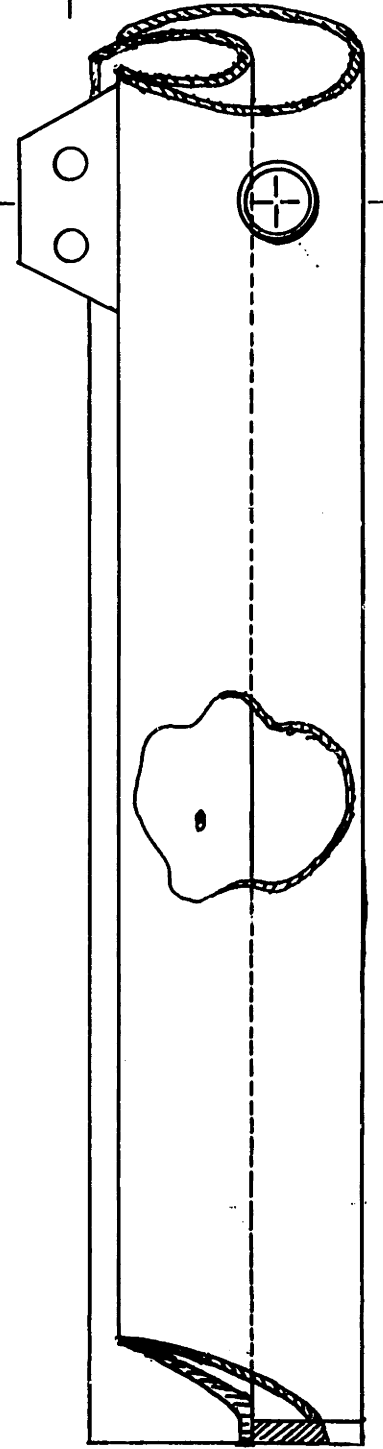
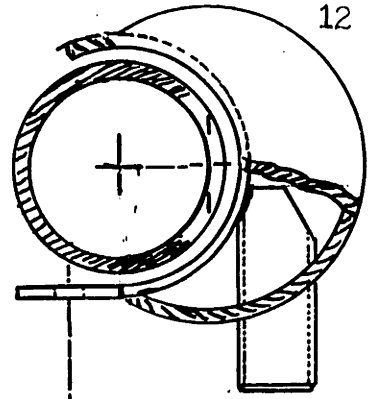

Figure 4
Vehicle Body
Full Scale

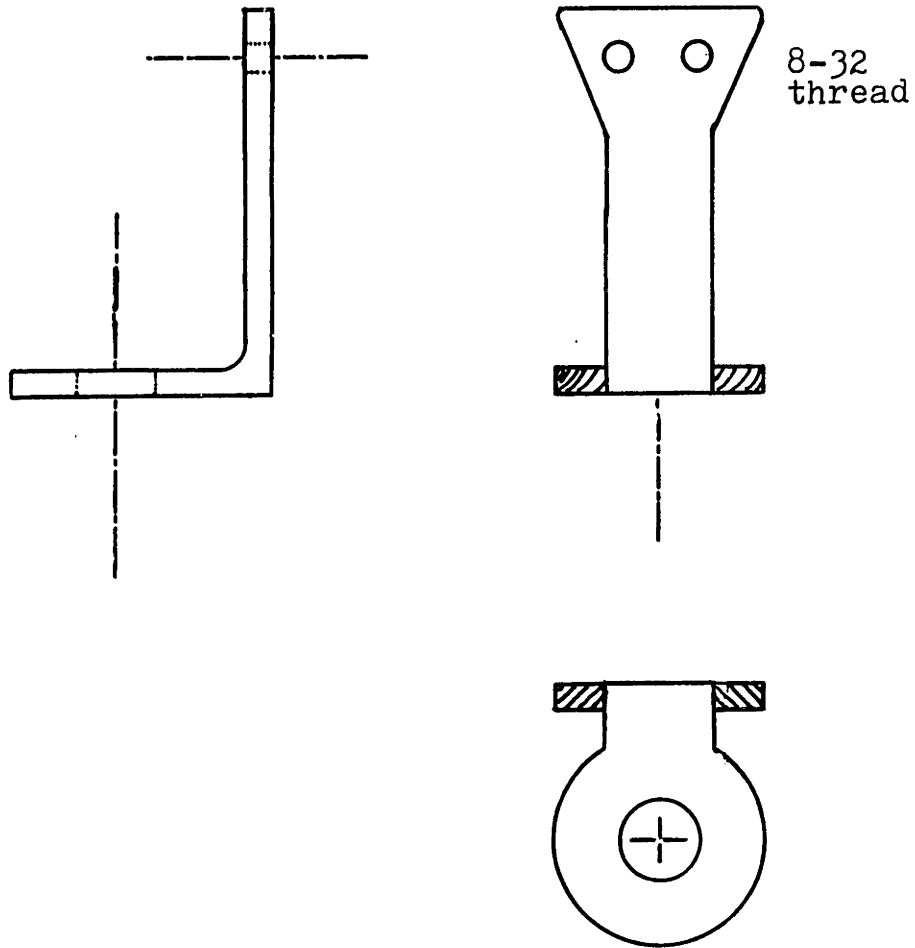

Figure 5
Cable Hanger Bracket
Full-Scale

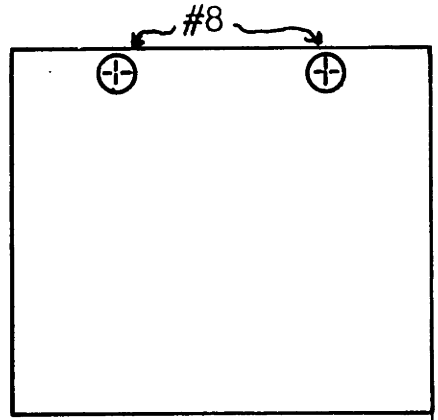
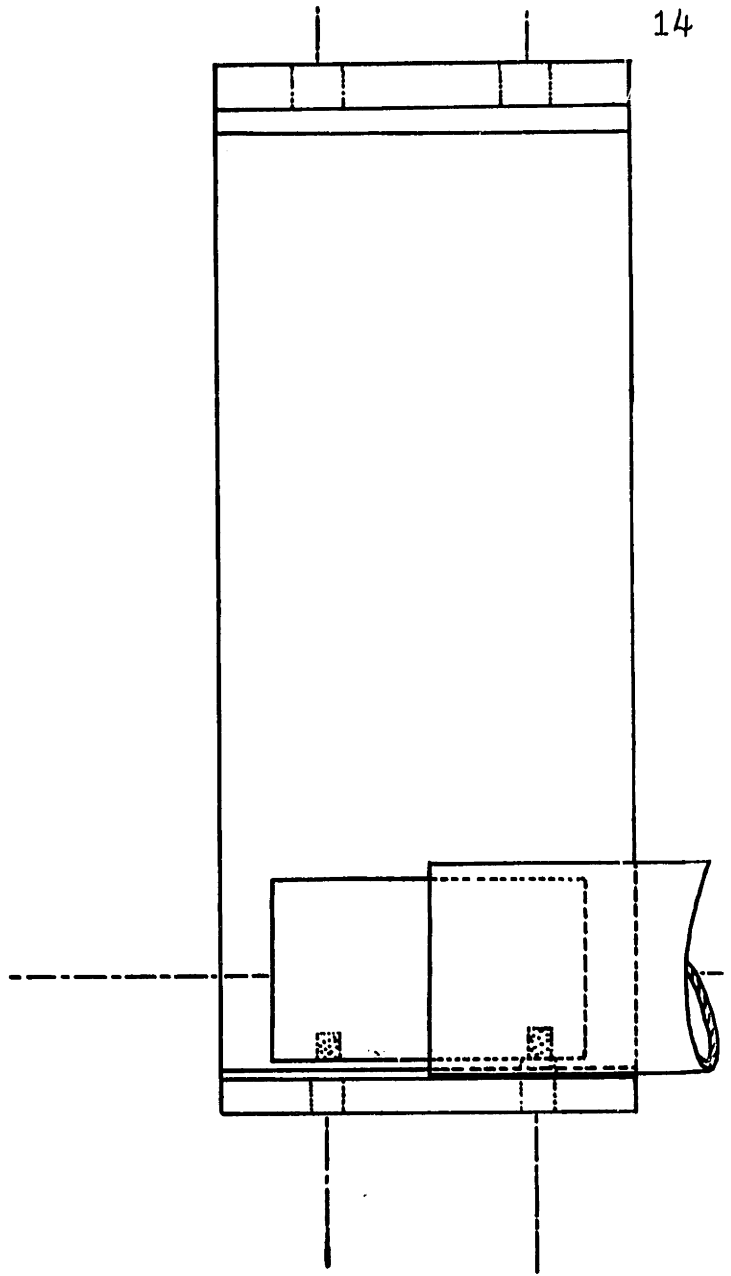
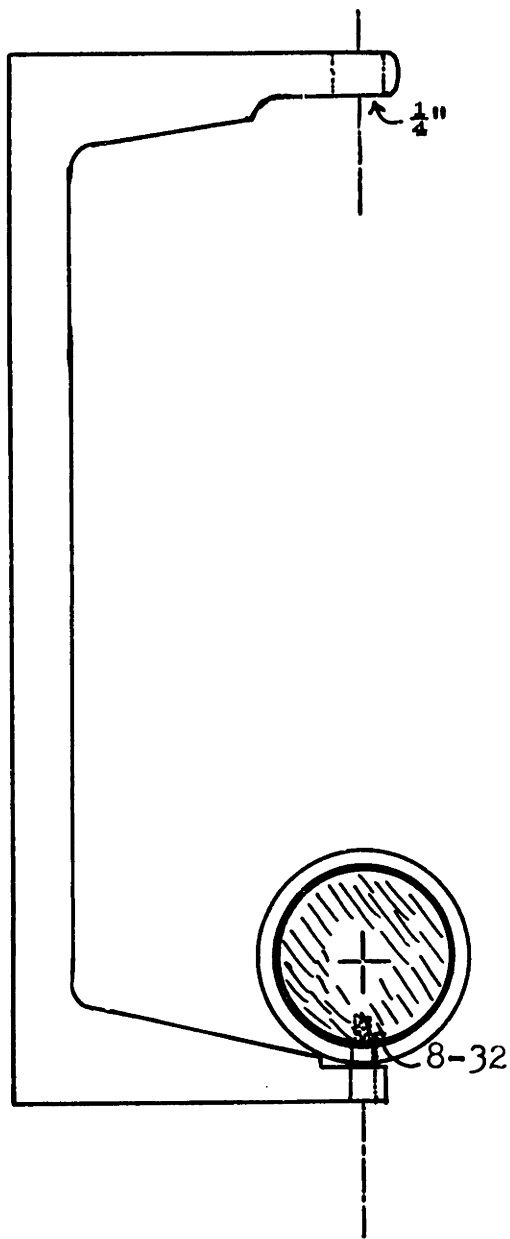

Figure 6
Track Mounting
Full-Scale

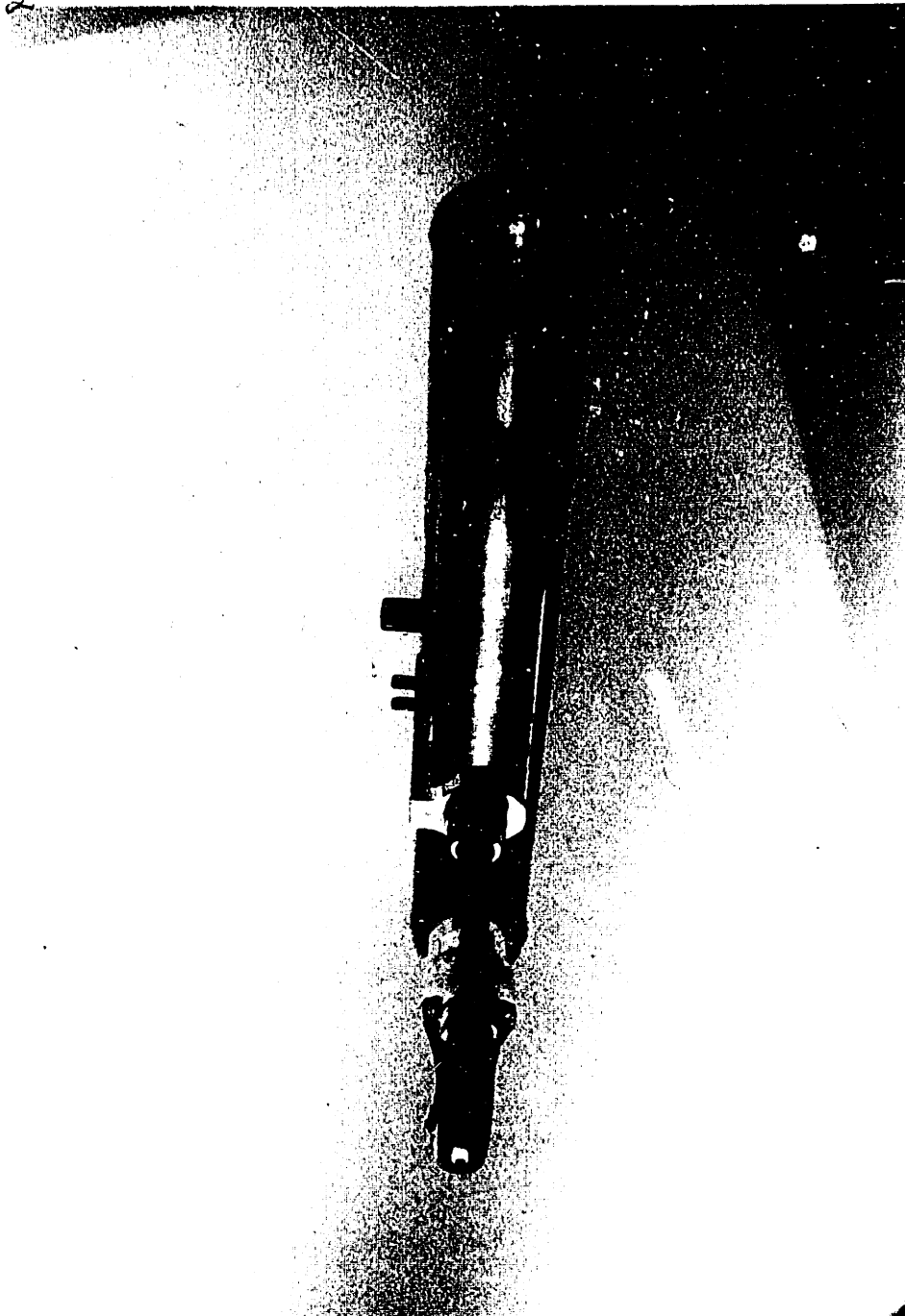

Figure 7: Vehicle, with cable hanger

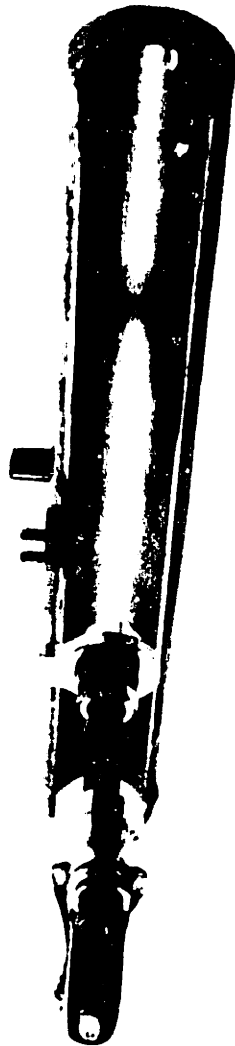

Figure 7: Vehicle, with cable hanger



Figure 8: Vehicle, end view

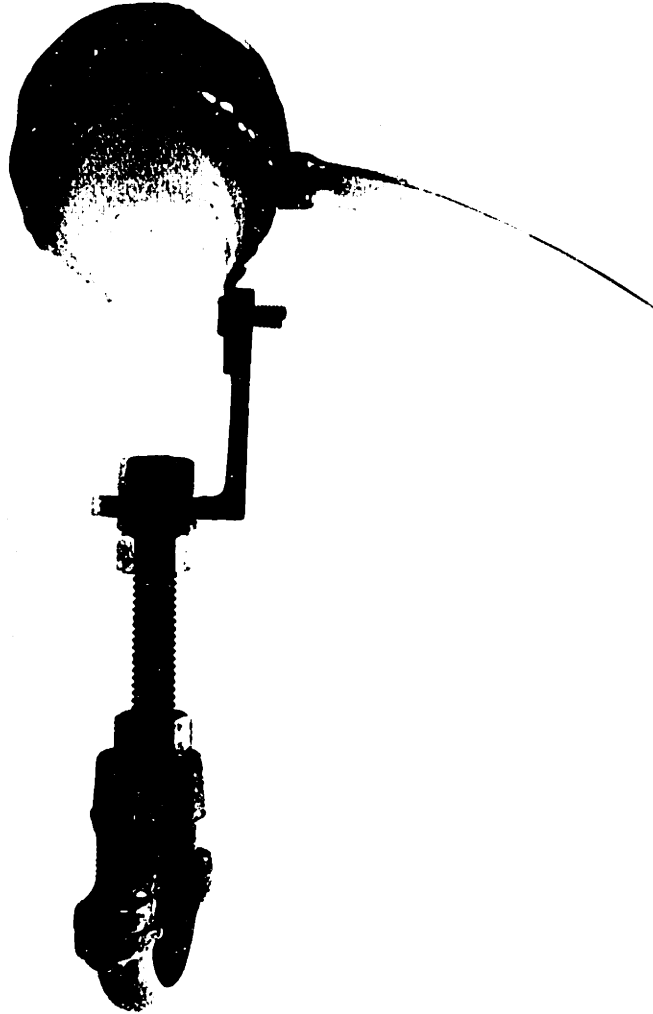

Figure 8: Vehicle, end view

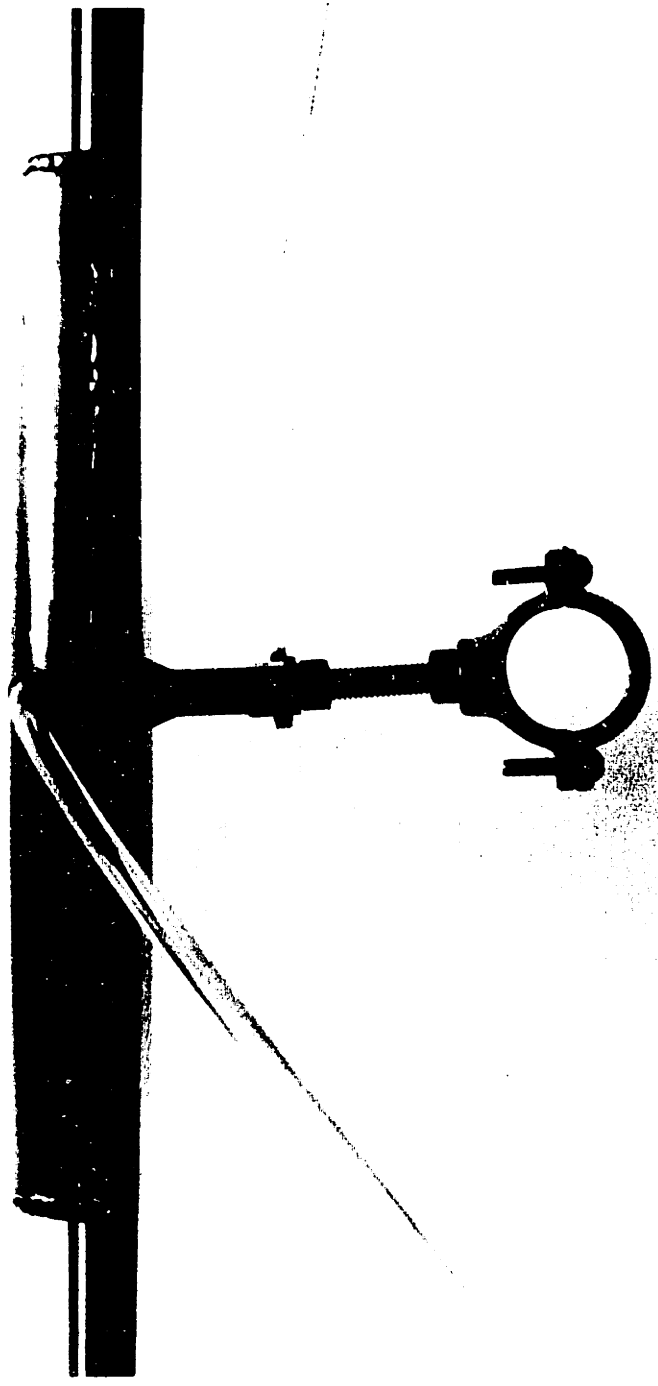

Figure 9: Vehicle, complete, on track

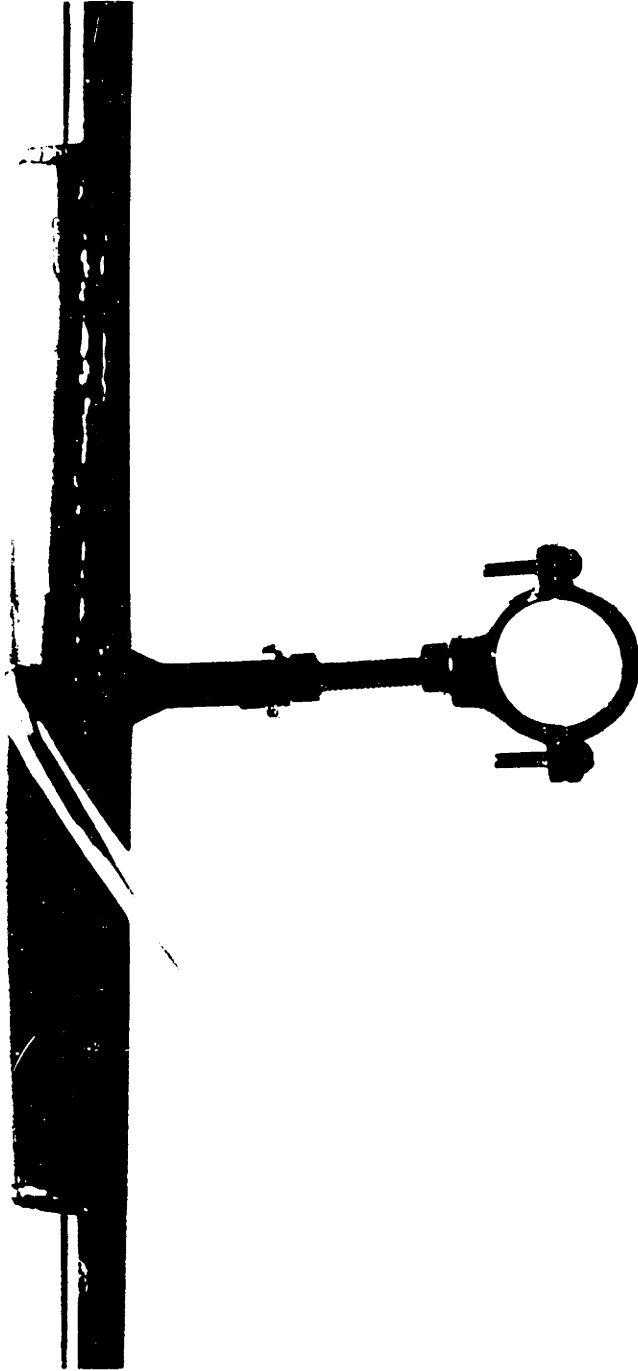

Figure 9: Vehicle, complete, on truck



Figure 10: Vehicle, track, and mounting

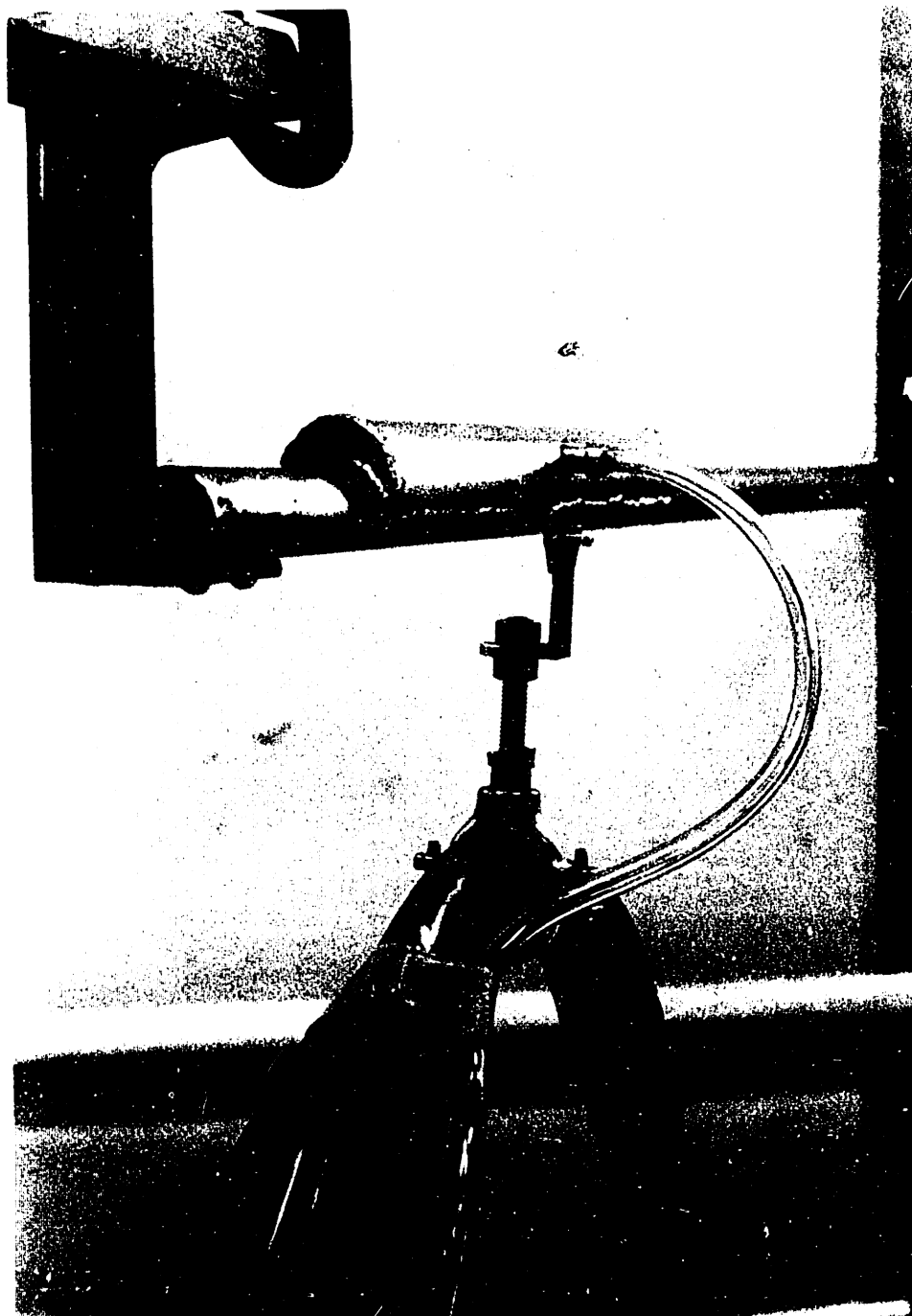

Figure 10: Vehicle, track, and mounting

to be slipped vertically onto the track.

The air inlet is a $3/8$ " x 1" copper tube whose inner end was beveled to fit the inside surface of the glider, the outer end chamfered, and epoxied in place.

The final vehicle weight was 12 ounces, including the 6-ounce steel cable hanger. For the test, air was supplied through six feet of $3/8$ " o.d. PVC tubing.

Testing:

Perliminary tests with a 125 psi source air supply showed that the vehicle performance was very sensitive to track diameter. With too small a track, the vehicle did not levitate. Possible improper and proper air-flow patterns are illustrated in Figure 11 below.

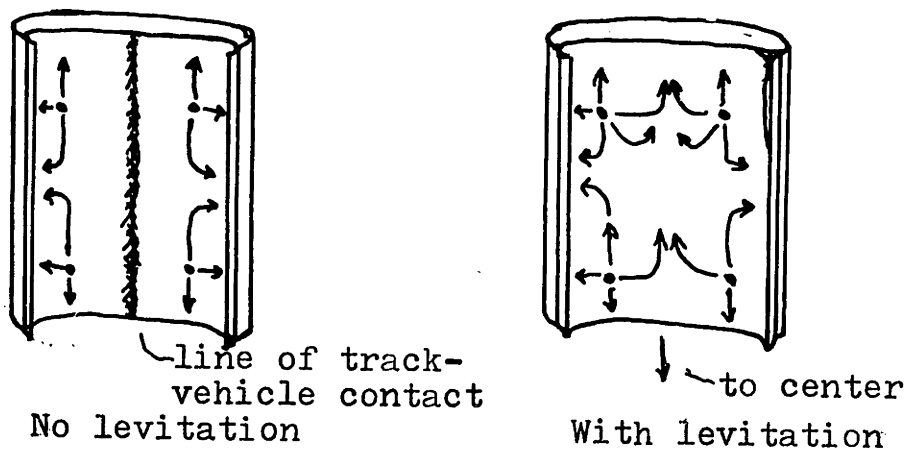

Figure 11: Air Flow patterns

To determine the quantitative effects of track diameter on vehicle performance, the following experiment was conducted:

Starting with a 2-foot length of $1-1/8$ " O.D. x .065" wall

aluminum tubing, 9 thousandths of an inch was tuned from the 20 diameter. At this point the "test track" fit snugly inside the vehicle, and ΔD , the minimum track-vehicle clearance, was zero. The diameter was reduced by another couple of thousandths, and the glider's performance tested. These diameter reduction & testing cycles were continued until the track's diameter was so small that the glider no longer floated with no payload and maximum air flow. The experiment's setup is shown below, in Figure 12.

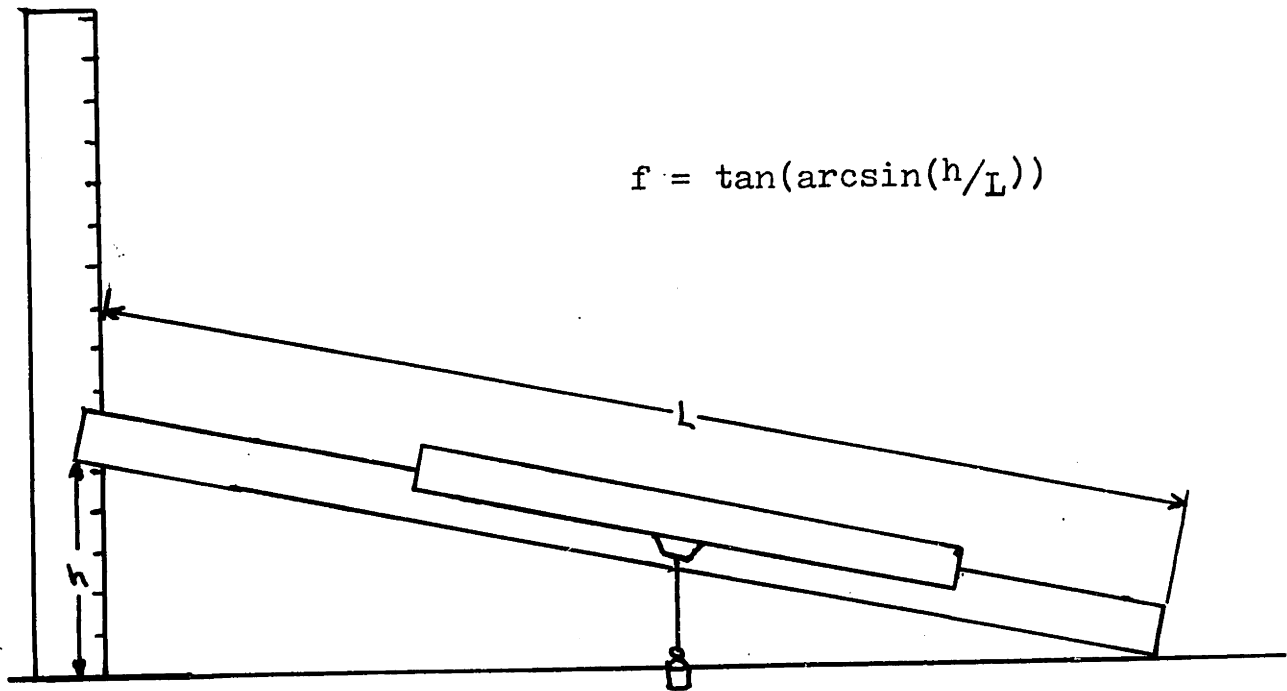

Figure 12; Vehicle Test Setup

The vehicle-track coefficient was found by slowly tilting the track until the glider began to slide. The coefficient of friction, f , was calculated from the elevation of the lifted end, h , and the length of the track, L .

With the vehicle running at full air flow, the pressure

at the air inlet tube was 10 psig, indicating that the system²¹ was supply-line-loss limited. By head-loss calculations (see Appendix), the maximum flow rate, at 70°F and 50psi, was found to be 1.4 ft³/sec.

Results:

The first graph, Figure 13, shows how the supply flow required for levitation varies with diameter difference ("AD"). As expected, more flow is required with a larger gap between vehicle and track.

Looking at the second plot, Figure 14, one sees that although the vehicle is in contact with the track in the range ($26 \leq \Delta D \leq 35$), the air flow still reduces the normal force and consequently the friction between the two surfaces. This air-cushion effect naturally diminishes as ΔD increases, until f is constant at the same value as when no air is flowing, 0.24. With a payload of 2 $\frac{1}{4}$ lbs., the loss of air-support occurs at a much smaller ΔD , 23 thousandths.

The third graph, Figure 15, shows the vehicle's response to pitching torques, with $\Delta D = .010$ ". These measurements were obtained by hanging a weight from a rigid arm fixed and parallel to the glider body. Note that f is still fairly low for a torque of 0.25 ft-lb. Yaw torques, much smaller than pitching torques since the cables can swivel about the vertical axis, are handled similarly.

During the experiment I observed the following phenomena: First, when the ΔD was less than ".008", any dust or dirt on

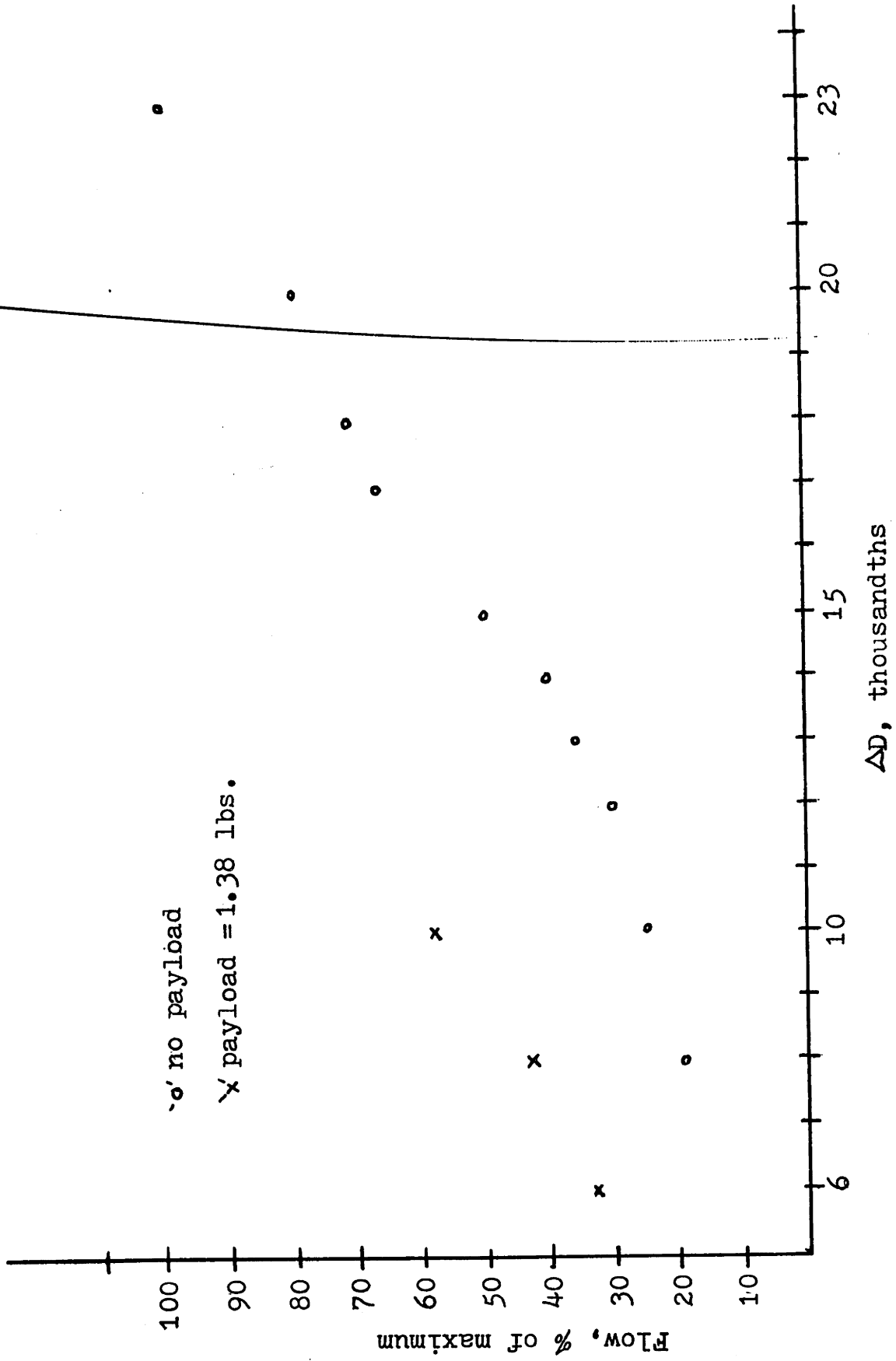

Figure 13: Flow required for levitation vs. ΔD

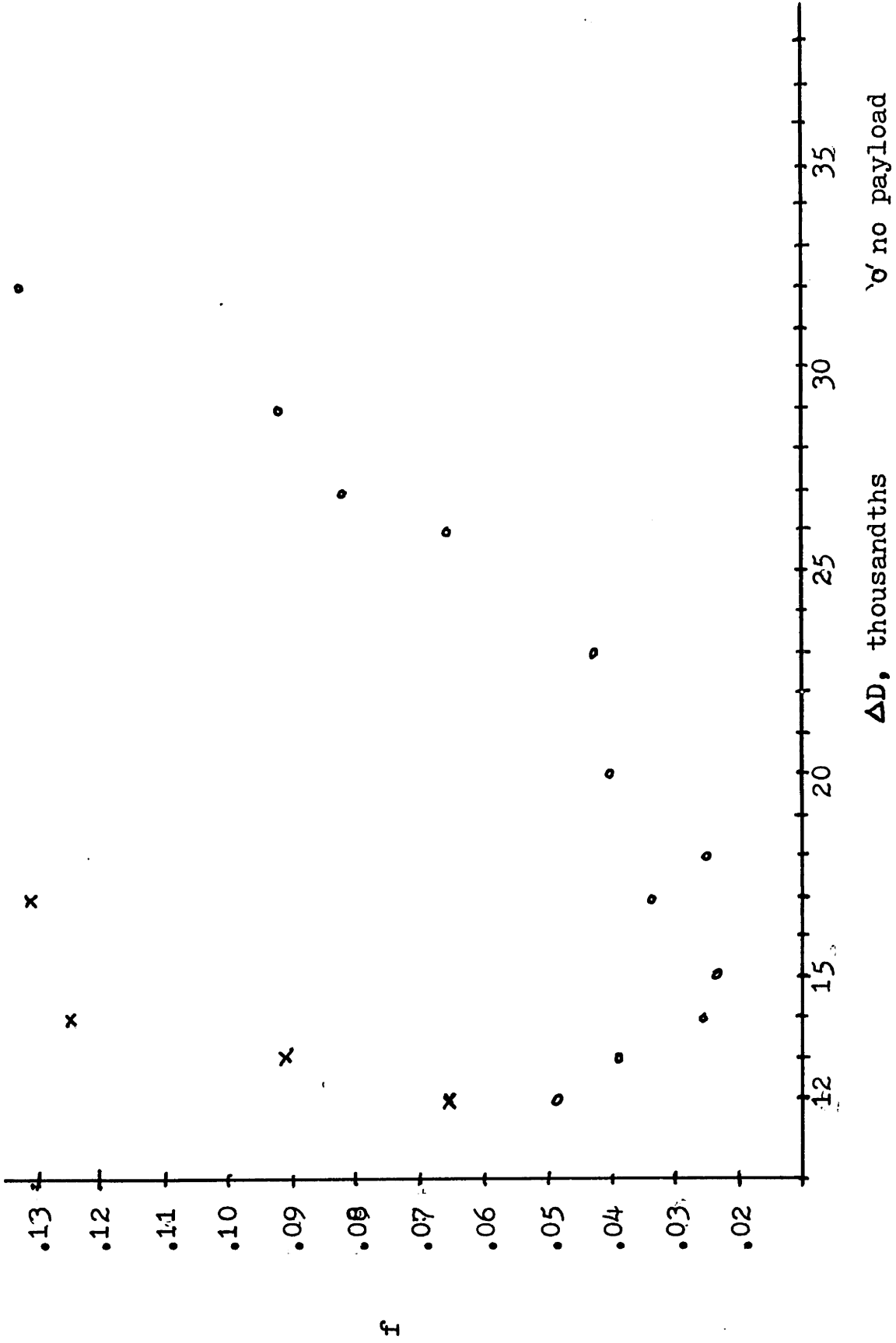

Figure 14: Friction coefficient, f, vs. ΔD

no payload
 payload = 2 1/4 lbs.

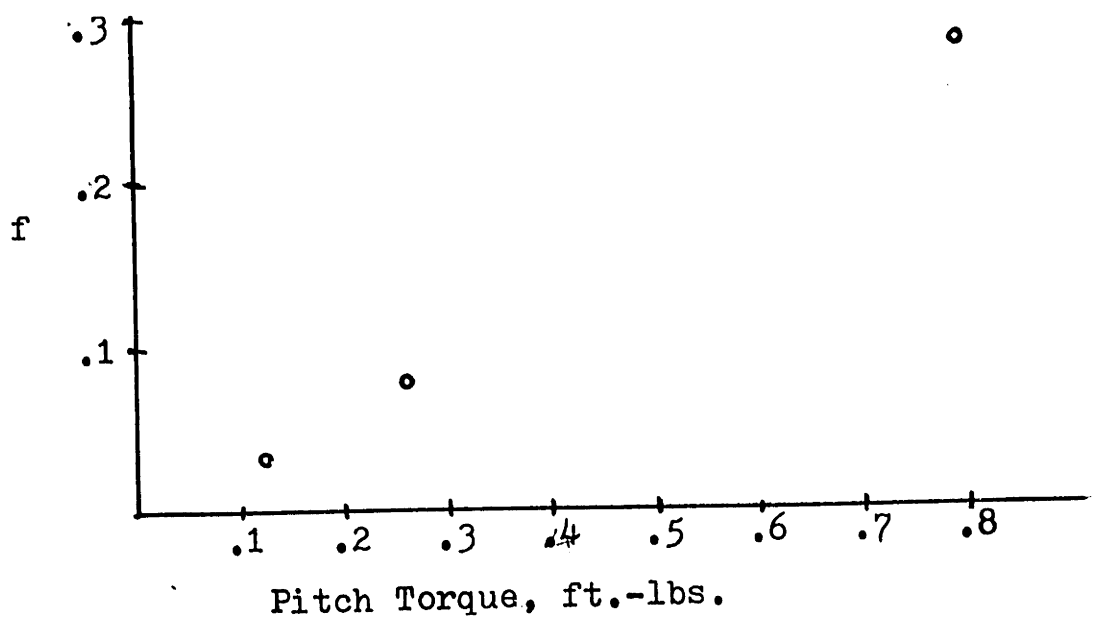

Figure 15: Friction coefficient, f, vs. torque

the track interfered with the vehicle's motion, resulting in a very high f. Second, even with full air flow the glider would not support more than five pounds payload with a D as small as .008". Third, the test track's larger diameter limited the vehicle's vertical motion (because the vehicle's inner tube wraps around more than 180°). Hence, if the air flow were too great the glider would rise until its bottom edges met the track, while if it were too little there would be no levitation, as shown in Figure 16 at the top of the next page. The vehicle's floating free required very careful adjustment of the air flow to the load. This effect was smaller when there was a load of 1 lb. or more on the vehicle, or when a small pitching torque was present. Fourth, when the vehicle was floating without touching the track, the coefficient of friction was constant, regardless of track size or payload, at about 0.013.

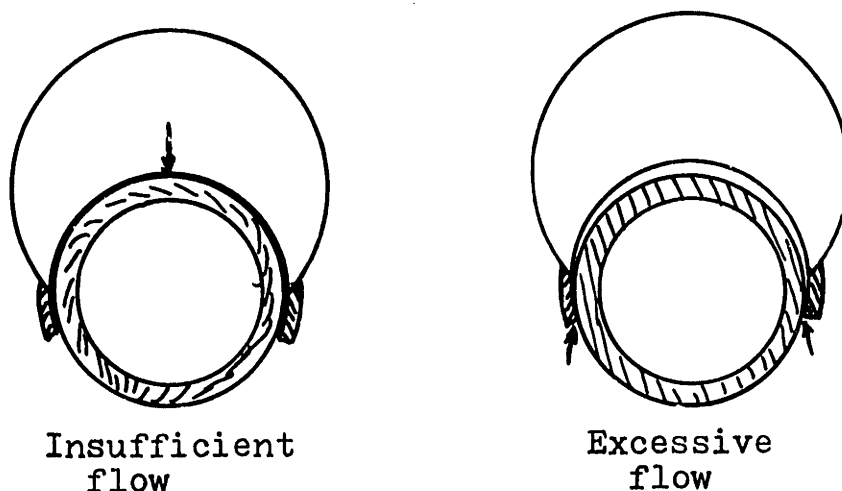

Figure 16: Modes of "bistable" vehicle behavior

At the beginning of the experiment the vehicle was tested with the track supported along its entire length by a rigid angle iron, and with it supported only at the ends. No difference in performance was noticed. Hence, track deflections of the magnitude normally encountered will probably have little or no effect on the vehicle, if ΔD is in the optimum range of 8 - 12 thousandths.

Conclusions:

The experiment described above pointed to necessary design changes. First, ΔD should be between 0.008" and 0.012". This will assure good lift, allow room for track imperfections and dirt, and provide a cushion to counteract pitch and yaw torques. Since it would be difficult to machine 60 feet of tubing to a tolerance of ± 0.002 ", the best method of accurately setting the gap is to bore out the inside of the vehicle's inner tube before welding. To avoid the bistable levitation situation shown in Figure 16, and to allow the levitation height to self-adjust to the load, the vehicle should not

wrap around the track more than 180° . The payload capability²⁶ can be increased in either of two ways: boosting the supply pressure (and hence the flow), or augmenting the air-cushion's area. The latter is accomplished by increasing the vehicle's length, or inside diameter, or both. If the present prototype were doubled in length it would support ten pounds payload, slightly more than required. Though the change in diameter necessary to achieve the same result must be determined by experiment, on the basis of area a factor of 2 might be adequate. For example, a vehicle running on a $2\frac{1}{4}$ "-diameter track might have twice the payload capacity of the prototype.

In setting up the system of eight working vehicles, one must consider whether to connect their air supplies in series or parallel, as shown below in Figure 17. If they are in series, the vehicle inlet pressure will be lower for a vehicle farther from the source, unless the supply line is large enough to act as a plenum rather than a contributor of head loss from

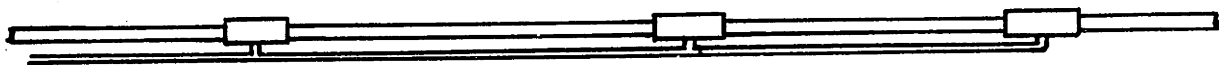

Series

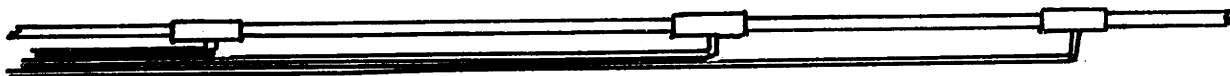

Parallel

Figure 17: Series and parallel hookup of air supply

one inlet to the next. The parallel arrangement avoids this ²⁷ problem but is clumsier, as the vehicle closest to the source must carry eight air hoses, the next one seven, and so on.

Alignment of adjoining ends of the 12-foot tubes which will compose the track will be insured by inserting a close-fitting bar at the joint, as shown in Figure 6.

The final consideration is money. The costs of the system are itemized below.

Track: 60' of 1 ¹ / ₈ " O.D.x.065" wall alum. tubing:	\$48
Supports: 3' 5"x 1 ³ / ₄ "-deep alum. channel:	\$9
Vehicles: 16' 1 ¹ / ₄ "x.065" alum. tubing:	\$14
16' 1 ¹ / ₂ "x.065" alum. tubing:	\$17
PVC tubing and other parts, approx.:	\$30
Welding, without volume discount: 8x\$35=	\$280
Total:	\$398

Operation will cost nothing, since compressed air (125 psi) is already piped into the lab.

For comparison, a 60-foot Stull-Ealing Air Track alone would cost about \$4600, and probably would not be adequate.

Considering the extent to which the prototype met the design criteria listed earlier, the conclusion of this thesis is that an air-levitated system would work very well, and would be economical to build and to operate.

Appendix:

In the line between the storage tank and the air outlet used in the experiment, are: 76 feet of $5/8$ " D pipe, 6 T-joints (all flow through branch, equivalent length = $60D$), and two wide-open gate valves (equivalent length of each = $13D$).

Conservation of energy tells us:

$$\Delta p / \rho - V_2^2 / 2 = f \cdot L / D \cdot V_2^2 / 2$$

$\Delta p = 110 - 10 = 100 \text{ psi}$, $\rho = .002378 \text{ slug/ft}^3$, $f = \text{friction factor}$

$D = 5/8" \rightarrow 12 \text{ in./ft.} \therefore L/D = 76 \cdot 96/5 + 360 + 26 = 1845$

The energy equation yields, upon solving for V_2 ,

$$V_2 = \left[\frac{2\Delta p}{\rho(fL/D + 1)} \right]^{1/2}$$

The friction factor f is found by trial-and-error: a value is tried, V_2 found, the Reynolds number calculated, and the corresponding value of f found on the "smooth" portion of a Moody diagram. This is repeated until the values of f , selected and obtained, match.

Results: $f = .015$, $V_2 = 650 \text{ ft./sec.} = 1.38 \text{ ft}^3/\text{sec.}$, for $5/8$ " dia. pipe = maximum air flow.

References:

1. "A Man-Interactive Simulator System for A/K Prostheses Studies"; Woodie C. Flowers & Robert W. Mann
25th ACEMB, October, 1972
2. "Theory of the Air-Supported Puck", W.M. Whitney,
American Journal of Physics , Vol. 32, No.4, April 1964
3. Introduction to Fluid Mechanics; R. Fox & A. McDonald,
Wiley & Sons, 1973
4. Hovercraft Design and Construction ; Gordon H. Elsley