

**ANALYSIS AND DESIGN OF SANDWICH PANEL
RESIDENTIAL ROOF SYSTEMS**

by

Mark John Kucirka

B.A./B.S. Lehigh University, Bethlehem, Pa, 1987

SUBMITTED TO THE DEPARTMENT OF CIVIL
ENGINEERING IN PARTIAL FULFILLMENT OF THE
REQUIREMENTS FOR THE DEGREE OF
MASTER OF SCIENCE IN CIVIL ENGINEERING

at the

MASSACHUSETTS INSTITUTE OF TECHNOLOGY

May 1989

Copyright (c) 1989 Massachusetts Institute of Technology

Signature of Author _____

Department of Civil Engineering
May 19, 1989

Certified by _____

Lorna Gibson
Thesis Supervisor

Accepted by _____

Ole S. Madsen
Department Committee on Graduate Studies

MASSACHUSETTS INSTITUTE
OF TECHNOLOGY

JUN 01 1989

LIBRARIES

ARCHIVES

ANALYSIS AND DESIGN OF SANDWICH PANEL RESIDENTIAL ROOF SYSTEMS

by

Mark John Kucirka

Submitted to the Department of Civil Engineering on May 19, 1989 in
partial fulfillment of the requirements for the degree of Master of Science
in Civil Engineering.

Abstract

Advantages of the use of sandwich panels in housing construction are: high specific stiffness and strength, good thermal insulation properties, improved quality control and product consistency as a result of employing industrialized manufacturing methods, flexibility in architectural design, and usable space in the enclosed roof cavity. In addition, there are reductions in: cost, labor, number of building components, operations and time for erection, enclosure, and finishing. Such attributes make sandwich panels excellent load carrying components in buildings. This thesis explores the use of sandwich panels in residential roofing systems. The structural analysis and design of the roof is developed and explored for various joining options and roof geometries: sandwich panel folded plate, panels supported by a ridge beam and panels tied by the floor system. An upper limit load case, as determined by the Uniform Building Code, is computed by an interactive fortran program giving load tables for various roof geometries. The critical effects of thermal and hygroscopic gradients on sandwich panel behavior are examined. Closed form solutions of the affect of thermal or hygroscopic gradients on two-way rectangular sandwich panel behavior indicate a severe impact on panel design. Large edge reactions and stresses are developed if panel slab edges are restrained from bowing. Deformations due to thermal and hygroscopic gradients are inversely proportional to the panel depth, and severely reduce panel stiffness performance. The importance of the effect of thermal and hygroscopic gradients on panel design and behavior has been overlooked by the code bodies. A fortran program, accounting for thermal and hygroscopic behavior, designs sandwich panels for a folded plate and ridge beam system. A preliminary joining system is developed for sandwich panel with an insulating structural core exposed to thermal or hgroscopic gradients. The proposed system is adaptable to a folded plate, ridge beam or floor tied system. The system is compatible with both wood frame and panelized wall systems. The joint design allows for the mis-alignment of wood frame construction to be dealt with at critical connections. Tolerance limitations, joint loads, preliminary joint design calculations, panel dimensions, construction sequencing and crane deployment are examined.

Thesis Supervisor: Lorna Gibson
Title: Winslow Associate Professor of Civil Engineering

Dedication

To my dog, Penny.

Table of Contents

Abstract	2
Dedication	3
Table of Contents	4
List of Figures	8
Symbols and General Terms	10
Definitions	16
1. Introduction	18
PART I. Analysis and Design of Residential Roof Sandwich Panels	22
2. Folded Plate Analysis	25
2.1 Review of Folded Plate Behavior	25
2.2 Plate Action	27
2.2.1 Plate Action Stresses	29
2.2.2 Plate Action Deflections	34
2.3 Slab Action	37
2.3.1 Influence of Support Connections	40
2.3.2 One-Way Slab Action	41
2.3.2.1 One-Way Slab Action Stresses	42
2.3.2.2 One-Way Slab Action Deflections	42
2.3.2.3 One-Way Monolithic Ridge Joint	43
2.3.3 Two-Way Slab Action	44
2.3.3.1 Two-Way Monolithic Ridge Joint	48
2.3.3.2 Short Folded Plates	49
2.3.4 Face Wrinkling	49
2.4 Roof Complexities	50
2.4.1 Roof Openings	50
2.4.2 Salt Box Roofs	51
2.4.3 Hipped Gable Roofs	52
3. Ridge Beam System	53
3.1 Review of One-Way Slab Action	53
3.1.0.1 One-Way Slab Action Stresses	54
3.1.0.2 One-Way Slab Action Deflections	54
3.2 Review of Plate Action	55
3.2.1 Plate Action Stresses	55
3.2.2 Plate Action Deflections	56
3.3 Ridge Beam Design	57
3.3.1 Ridge Beam Design Example	59
3.3.1.1 structural glued laminated beam	59
3.3.1.2 laminated veneer lumber beam	60
3.4 Comparison of Ridge Beam to Folded Plate System	61
4. Floor Tied System	63
4.1 Buckling of Sandwich Panels	63

4.2 Combined Loads	64
5. Thermal and Hygroscopic Stresses and Deflections in Sandwich Panels	65
5.1 Introduction	65
5.2 Thermal Analysis of a Sandwich Beam	66
5.2.1 Unrestrained Sandwich Beam Behavior	66
5.2.2 Restrained Sandwich Beam Behavior	67
5.3 Thermal Analysis of a Two-way Sandwich Slab	67
5.3.1 Two-way Sandwich Slab Assumptions	68
5.3.2 Two-way Slab with Two Opposite Edges Simply Supported and Remaining Edges Free	68
5.3.3 Two-way Sandwich Slab with Four Edges Simply Supported	71
5.4 Precision	72
5.5 Infinite Corner Reactions	73
5.6 Effect of Panel Width	73
5.7 Computer Programs	74
5.8 Effect of Core Depth	74
5.9 Changes in Length	75
6. Code Design	77
6.1 Uniform Building Code 88	77
6.2 Uniform Building Code 88 Design Loads	78
6.2.1 Roof Snow Loads	78
6.2.1.1 Alternate Roof Snow Load Design Procedure	79
6.2.2 Roof Wind Loads	81
6.2.3 Roof Earthquake Loads	83
6.3 Joint Loads	85
6.4 Proposed Code Revisions	85
6.5 Factor of Safety	86
6.6 Design Method	87
PART II. Sandwich Panel Residential Roof System	89
Introduction	90
7. Joint Design	91
7.1 Introduction	91
7.2 Tolerances	91
7.2.1 Tolerance Limitations	93
7.2.1.1 Summary of Tolerance Limitations	96
7.3 Ridge Line Connection	97
7.3.1 Edge Stiffener	97
7.3.1.1 Edge Stiffener Summary	105
7.3.2 Ridge Edge Fastener	105
7.3.2.1 Separation Block	106
7.3.2.2 Ridge Beam Accessories	109
7.3.2.3 Folded Plate and Floor Tied Ridge Edge Fastener	112
7.3.2.4 Preliminary Hinge Design	113
7.3.2.5 Redundant Ridge Edge Fastener	119
7.3.2.6 Ridge Fastener Noise	122
7.3.2.7 Ridge Edge Fastener Summary	122
7.3.3 Insulation	123

7.3.4 Weather Sealing	123
7.3.5 Edge Stiffener Tension Splice	124
7.3.5.1 Tension Splice Summary	126
7.4 Longitudinal Wall Connection	127
7.4.1 Eave Overhangs	127
7.4.2 No Eave Overhangs	128
7.4.3 Eave Edge Fastener	129
7.4.3.1 Panelized Longitudinal Wall System	132
7.4.3.2 Wood Frame Longitudinal Wall System	133
7.4.3.3 Tied Floor System Accessory	134
7.4.3.4 Tension Cables	137
7.4.3.5 Eave Edge Fastener Summary	140
7.4.4 Insulation	140
7.5 Gable Connection	141
7.5.1 Trussed Gable Endwall	142
7.5.2 Gable Edge Stiffener	142
7.5.2.1 Gable Edge Stiffener Summary	144
7.5.3 Gable Edge Fastener	144
7.6 Panel to Panel Connection	146
7.6.1 Panel Web Concept	151
7.6.1.1 Preliminary Web Design	154
7.6.1.2 Utilities	155
7.6.1.3 Frostlines and Thermal Bridge	155
8. Construction Sequence	157
8.1 Introduction	157
8.2 Redundancy in Folded Plate	159
8.2.1 Construction Assembly Sequencing	160
8.3 Crane Specifications	161
8.4 Roof Panel Width	162
8.4.1 Handling	163
8.4.2 Crane Limitations	163
8.4.3 Waste	164
8.4.4 Edge Stiffner Dimensions	164
8.4.5 Joining System	165
8.4.6 Transportation Limitations	166
8.5 Crane Deployment	166
8.5.1 Lifting and Hooking	176
8.5.1.1 Ridge Crane Hook	176
8.5.1.2 Double-Action Crane Winch	178
9. Conclusions	180
9.1 Recommendations for Further Research	183
Computer Program Appendix	184
Appendix A. Program Panel.f	186
A.1 Program Variables	186
A.2 Program Description	192
A.3 Panel.f Hard Copy	198
A.4 Panel.f Output	220
Appendix B. Program S.f Hard Copy	225

B.1 S.f Output	231
Appendix C. Program B.f Hard Copy	240
C.1 B.f Output	246
Appendix D. Program Sep.f Hard Copy	259
D.1 Sep.f Output	274
Appendix E. Program Comb.f Hard Copy	287
E.1 Comb.f Output	297

List of Figures

Figure 1: Single Bay, Simple Span, Folded Plate	17
Figure 1-1: Panel Types	20
Figure 1-2: Roof Structural Systems	23
Figure 2-1: Schematic of Folded Plate Action	26
Figure 2-2: Force Diagram of Transverse Cross Section	28
Figure 2-3: Uniform In-Plane Load	29
Figure 2-4: Deep Girder Beam	30
Figure 2-5: Geometry of Deflections	38
Figure 2-6: Plan View of Folded Plate Panel	45
Figure 2-7: Wrinkling of the Compression Face (after Allen 1969)	50
Figure 5-1: Two-way Sandwich Slab with Two Opposite Edges Simply Supported and Remaining Edges Free	69
Figure 5-2: Panel with Four Edges Simply Supported	72
Figure 7-1: Joint Conditions	92
Figure 7-2: Roof Tolerances	94
Figure 7-3: Edge Fastener Location and Stiffener Loads	99
Figure 7-4: Ridge Edge Fastener	107
Figure 7-5: Hinged Panel Units with Ridge Edge Fastener	108
Figure 7-6: Ridge Beam Ridge Line Connection	111
Figure 7-7: Folded Plate and Floor Tied Ridge Line Connection	112
Figure 7-8: Pull Loads on the Hinge Plate Section	115
Figure 7-9: Push Loads on the Hinge Plate Section	116
Figure 7-10: Hinge Load Forces	117
Figure 7-11: Redundant Ridge Edge Fastener	121
Figure 7-12: Edge Stiffener Tension Splice	125
Figure 7-13: Lateral Longitudinal Wall Kick Out	130
Figure 7-14: Hinge Pair with Eave Edge Fastener	131
Figure 7-15: Panelized Longitudinal Wall Eave Connection	133
Figure 7-16: Wood Frame Longitudinal Wall Eave Connection	135
Figure 7-17: Mis-aligned Wood Frame Longitudinal Wall Eave Connection	136
Figure 7-18: Mis-aligned Wood Frame Longitudinal Wall Eave Connection	137
Figure 7-19: Tied Floor System Eave Connection	138
Figure 7-20: Tension Tie for Cables	139
Figure 7-21: Trussed Gable Endwall	143
Figure 7-22: Thermal and Hygroscopic Bowing of the Gable Edge Stiffener	145
Figure 7-23: Detail of Panel Gable Endwall as Viewed Along the Gable Line	146
Figure 7-24: Detail of Stud Gable Endwall as Viewed Along the Gable Line	147
Figure 7-25: Panel to Panel Geometry	149
Figure 7-26: Panel to Panel Web Accessories	152
Figure 7-27: Panel to Panel Connection	156
Figure 8-1: Crane Deployment Sequence	169
Figure 8-2: Crane Deployment Sequence	170
Figure 8-3: Crane Deployment Sequence	171
Figure 8-4: Crane Deployment Sequence	172
Figure 8-5: Crane Deployment Sequence	173
Figure 8-6: Crane Deployment Sequence	174
Figure 8-7: Crane Deployment Sequence	175

Figure 8-8: Ridge Crane Hook (refer to Figure 7-5 for hinge orientation)	177
Figure 8-9: Eave Crane Hook	178
Figure A-1: Program <i>Panel.f</i> Flowchart	193

Symbols and General Terms

α = Angle between the roof surface and the horizontal (degrees).

$$\alpha_m = \frac{m \pi b}{2H}$$

α_t = Thermal coefficient of expansion for the face material ((-)/°F).

α_{ti} = Coefficient of thermal expansion of the i face ((-)/°F).

δ_1 = Flexural "one-way slab" deflection (in.).

δ_2 = Shear "one-way slab" deflection (in.).

δ_h = Eave line member splice "plate" deflection (in.).

δ_f = Flexural "plate" deflection (in.).

δ_h = Horizontal "plate" deflection (in.).

δ_s = Shear "plate" deflection (in.).

δ_{ss} = Seam slip "plate" deflection (in.).

δ_v = Vertical "plate" deflection (in.).

ϵ_1, ϵ_2 = Unit dimensional change of opposite faces (-).

ϵ_i = Strain due to thermal effects of i face (-).

$$\gamma_m = \frac{r_m b}{2}$$

ν_f = Poisson's ratio of the face material (-).

$$\lambda_m = \frac{m \pi}{H}$$

σ_{all} = Allowable unit stress (p.s.i.).

σ_c = Bending stress in the core in the transverse direction (p.s.i.).

σ_{cp} = Bending stress in the core in the longitudinal direction (p.s.i.).

σ_e = Axial stress in the longitudinal line member (p.s.i.).

σ_f = Bending stress in the face in the transverse direction (p.s.i.).

σ_{fp} = Bending stress in the face in the longitudinal direction (p.s.i.).

τ_c = Out-of-plane shear stress in the core (p.s.i.).

τ_{cp} = In-plane shear stress in the core (p.s.i.).

τ_{fp} = In-plane shear stress in the faces (p.s.i.).

b = Width of panel element (in.).

b_r = Width of ridge beam (in.).

c = Thickness of sandwich core (in.).

$corner_{error}$ = maximum error in corner layout (in.).

d = Distance between the centerlines of the two sandwich faces (in.).

d_r = Depth of ridge beam (in.).

$diagonal_{error}$ = difference between diagonals from opposite corners (in.).

ei = Flexural rigidity of the composite panel in the transverse direction (lb.*in.²).

f = Allowable displacement factor (i.e. Length of span/ f = Allowable displacement) (-).

f_b = Actual unit stress for extreme fiber in bending (p.s.i.).

f_c = Actual unit stress in compression parallel to the grain (p.s.i.).

f_t = Actual unit stress in tension parallel to the grain (p.s.i.).

f_v = Actual unit horizontal shear stress (p.s.i.).

h = Overall depth of sandwich panel (in.).

$p_m = \{\lambda_m^2 + [2 G_c t_c / (1 - \nu_f) ei]\}^{1/2}$

p_w = Design wind pressure (p.s.i.).

q_s = Wind stagnation pressure at the standard height of 30 feet as set forth in Table No. 23-F [U.B.C., 88] (-).

t = Thickness of the faces of the sandwich panel (in.).

t_c = Distance between the centerlines of the two sandwich faces (in.).

t_e = Thickness of the edge stiffener (in.).

x = Longitudinal distance with origin at gable line (in.).

y = Transverse distance with origin at midspan (in.).

w = Deflection of panel including shear deflections (in.).

w' = Deflection of "two-way slab" neglecting shear deflections (in.).

w'' = Deflection of "two-way slab" neglecting shear deflections due to a moment, M_y , applied to the ridge line (in.).

w_d = Dead load per unit area of sandwich panel (p.s.i.).

w_e = Transverse deflection of the edge stiffener due to girder action (in.).

w_l = Live load per unit horizontal projected area (p.s.i.).

w_{px} = weight of the diaphragm and tributary elements connected thereto at level x (lbs.).

w_s = Total out-of-plane slab load per unit area of sandwich panel (p.s.i.).

A_e = Area of high strength continuous longitudinal line member at the eave (in.).

A_m = Constant (-).

A_p = Transformed transverse cross sectional area of sandwich panel (in.²).

B = Horizontal projected distance between fold line and eave line (in.).

B_m = Constant (-).

C_{exp} = Snow exposure coefficient (-).

C_e = Combined height, exposure and gust factor coefficient as given in Table No. 23-G [U.B.C., 88] (-).

C_f = Size factor for beams deeper than 12 inches (-).

C_s = Snow reduction coefficient for slope friction (-).

C_q = Pressure coefficient for the structure or portion of structure under consideration as given in Table No. 23-H [U.B.C., 88] (-).

D = Vertical projected distance between fold line and eave line (in.).

E_c = Young's Modulus of core material in transverse direction (p.s.i.).

E_{cp} = Young's Modulus of core material in longitudinal direction (p.s.i.).

E_e = Young's Modulus of edge stiffener (p.s.i.).

E_f = Young's Modulus of face material in transverse direction (p.s.i.).

E_{fp} = Young's Modulus of face material in longitudinal direction (p.s.i.).

E_m = Constant (-).

E_r = Young's modulus of ridge beam material (p.s.i.).

F_b = Allowable unit stress for extreme fiber in bending (p.s.i.)

F'_b = Allowable unit stress for extreme fiber in bending, adjusted for slenderness (p.s.i.).

F_c = Allowable unit stress in compression parallel to the grain (p.s.i.).

F'_c = Allowable unit stress in compression parallel to the grain adjusted for buckling (p.s.i.).

F_{px} = Roof diaphragm force (lbs.).

F_t = Allowable unit stress in tension parallel to the grain (p.s.i.).

F_v = Allowable unit horizontal shear stress (p.s.i.).

G_c = Out of plane shear modulus of core material (p.s.i.).

G_{cp} = In-plane shear modulus of core material (p.s.i.).

G_f = In-plane shear modulus of face material (p.s.i.).

H = Slope distance between the fold line and the eave line (in.).

I = Occupancy importance factor (-).

I_e = Moment of inertia of edge stiffener (in.⁴).

I_p = Transformed moment of inertia of transverse cross section of sandwich panel (in.⁴).

I_{req} = Required moment of inertia of the ridge beam (in.⁴).

K_e = Design buckling factor (-).

L = Horizontal distance between gable lines, folded plate span (in.).

L_r = Length of the ridge beam (in.).

M_e = Moment of the edge stiffener due to girder action (lb.*in.).

M_r = Maximum moment of the ridge beam (lb.*in.).

M_x = Longitudinal "two-way slab" moment (lb.*in.).

M_{xy} = Twisting "two-way slab" moment (lb.*in.).

M_y = Transverse "two-way slab" moment (lb.*in.).

P = Concentrated load per unit length in the longitudinal direction (lb./in.).

P_g = Ground snow load (p.s.i.).

P_f = Roof snow load (p.s.i.).

Q_p = In-plane shear force (lb.)

Q_x = Out-of-plane "two-way slab" shearing forces in the longitudinal plane (lb.).

Q_y = Out-of-plane "two-way slab" shearing forces in the transverse plane (lb.).

R = Reaction forces at the corners of a folded plate due to "two-way slab" action (lb.).

R_c = Radius of panel curvature (in.).

R_s = Snow load reduction in pounds per square foot per degree of pitch over 20 degrees.

S = Total snow load (p.s.f.).

S_{req} = Required section modulus for the ridge beam (in.³).

T = Difference between the average temperature of the two faces (°F).

T_i = Temperature change of the i face from the reference condition (°F).

V_e = Vertical panel edge reaction at the eave line (lb./in.).

V_r = Vertical panel edge reaction at the ridge line (lb./in.).

V_x = The reaction along the eave and ridge line (lb.).

W_p = Total in-plane plate load per unit length (lb./in.).

Z = Seismic zone factor (-).

Definitions

Individual "panel elements" are butted and joined together to form the two roof "panels" of the folded plate structure (refer to Figure 1).

The "length", (L), of a panel is the horizontal distance between gable lines, in the longitudinal direction (Figure 1).

The "height", (H), of a panel is the slope distance between the fold line and the eave line, in the transverse direction (Figure 1).

The "aspect ratio" is the ratio of the length to height of the panel (L/H).

In conformance with the terminology introduced by Winter & Pei (1947), "slab" action refers to the flexure of individual panels out of their planes, and "plate" action refers to the in plane extensional deformation of the panels.

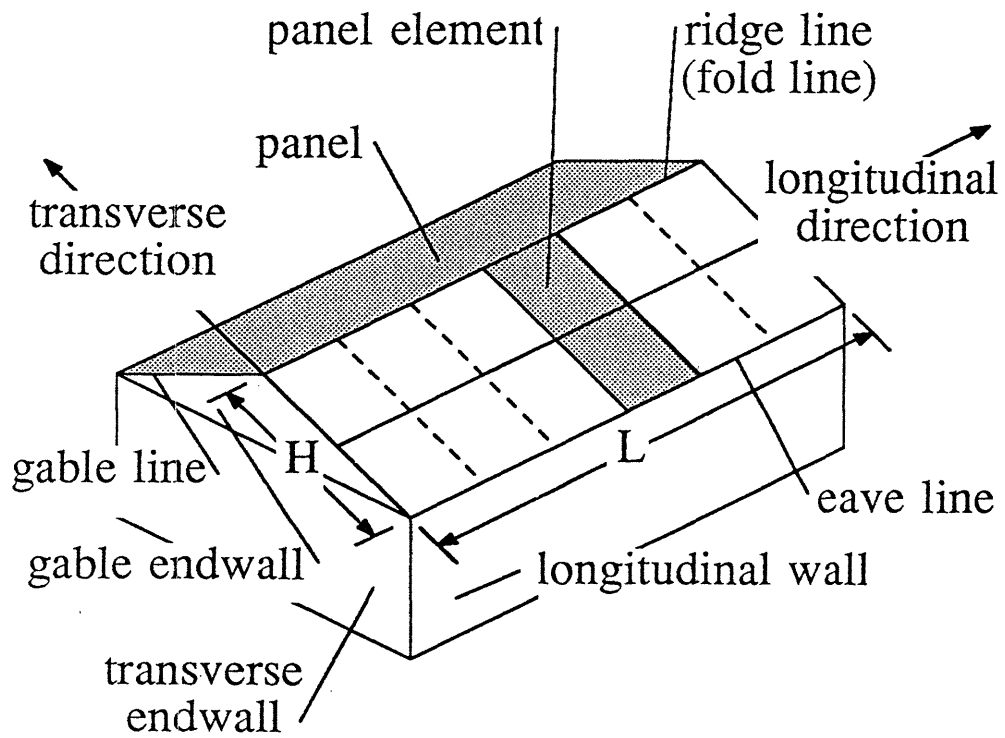
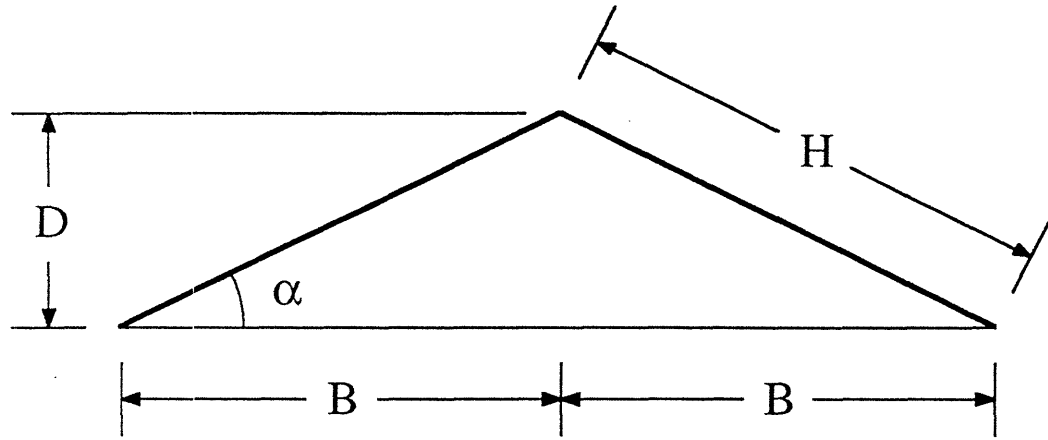

Figure 1: Single Bay, Simple Span, Folded Plate

Chapter 1

Introduction

This thesis is part of a larger research effort at M.I.T. entitled "Innovative Housing Construction Technologies." The major goal of the project is to identify and propose new technologies capable of radically improving both the quality and affordability of newly constructed housing in the U.S.

As a starting point, the initial research has focused on the roof structural system for the following reasons:

1. The roof can be defined as a single building subsystem, allowing for the detailed study of an individual system, while recognizing that this system must be integrated into the whole.
2. Roof panels represent a challenging problem of long span structures under transverse loading; encompass issues of weather sealing, and present complex joint conditions.
3. The roof design minimizes the complicating aspects of integrating building utilities (electrical, plumbing, mechanical) when evaluating the structural, thermal, and environmental aspects of the building envelope.
4. Improving the technology of roof systems is a specific need that has been identified by builders in the marketplace.

The technology developed in the study of roofing systems can easily be transferred into panelized wall or floor systems. Presently there are many panelized wall systems available on the market, but few sandwich panels capable of spanning long distances required of floors and roofs.

The apparent market trend in residential homes is toward complex roof shapes and cathedral ceilings. An inspection tour of a recent, higher-end, housing construction will support this statement. Architectural roof shapes, and the interior spaces created are a powerful marketing tool used to personalize and customize homes. Customers in the high-

end of the home market demand an individualized product. American home builders are meeting market needs with conventional building systems which are ill-suited for these complex shapes. The cost, number of parts and steps involved in the constructing a conventionally framed complex roof are large. Moreover, the number of skilled carpenters in the labor force capable of performing such work is shrinking. Sandwich panel roof construction could offer a solution to this dilemma. Sandwich panels are constructed by bonding strong, stiff faces to either side of a thick lightweight core. Conceptually, sandwich panel roof structure could be constructed like a cardboard architecture model. Sheets of foamcore (conceptual sandwich panels) are laid on top of, and joined to the underlying boxed structure of the house. A simple and easily assembled roof system gives immediate enclosure to the building shell. A roof system which meets the constructibility issues of complex roofs may also bridge the gap with affordable housing.

Advantages of the use of sandwich panels in housing construction are: high specific stiffness and strength, good thermal insulation properties, improved quality control and product consistency employing industrialized manufacturing methods, flexibility in architectural design, and usable space in the enclosed roof cavity. In addition, there are reductions in: cost, labor, number of building components, operations and time for erection, enclosure, and finishing. Such attributes make sandwich panels excellent load carrying components in buildings. This thesis explores the use of sandwich panels in the roofing system of housing.

There are three types of panel construction available to residential roofing (see Figure 1-0).

Panel type one is correctly referred to as a stressed-skin construction, while the others are strictly referred to as sandwich panels. The scope of the thesis will be narrowed to the discussion of sandwich panel types two and three.

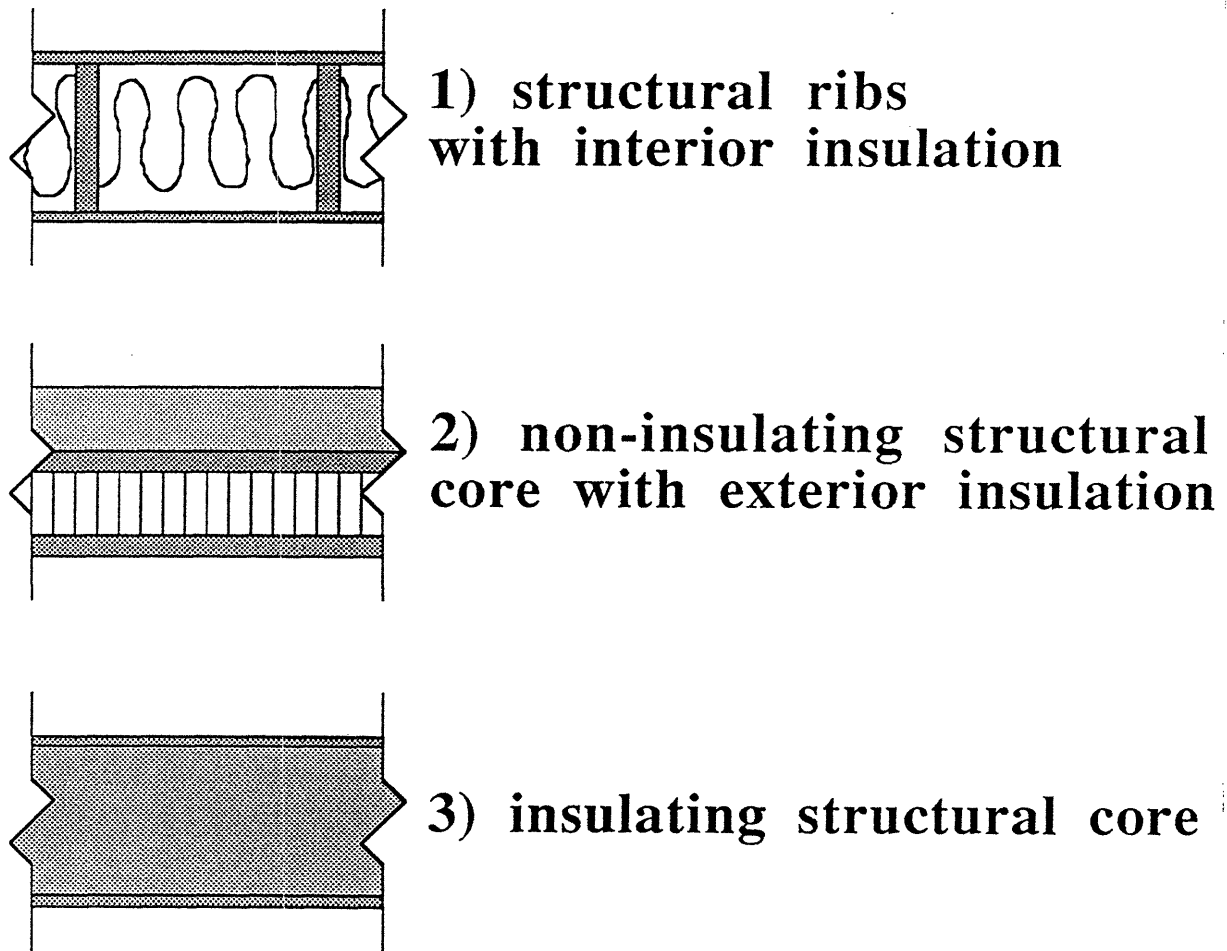

Figure 1-1: Panel Types

The Housing Construction Technology Consortium of MIT sponsored this research. The six members, as of May 1989, are: USG, Mobay, ITW, ALCAN, Weyerhaeuser, and GE Plastics. A Building Advisory Group was formed to help in establishing the direction of the research. Members were drawn from the leaders in American home building: Wood Structures, Inc., Gebhardt Associates, Acorn Structures, Winchester Homes Inc., Winter Panel Corporation, and Ryan Homes Inc.. Academic advisors to the project are: Prof. Lorna Gibson of the Civil Engineering Department, Mr. John Crowley of the Laboratory

for Architecture and Planning, and Prof. Leon Glicksman of the Building Technology Group. Students under the project at this time are: Tim Tonyan, a Ph.D. candidate in Civil Engineering, who is working on materials selection, defining panel requirements, and developing cementitious foamed cores; Gebran Karam, a S.M. student in Civil Engineering, who is studying the structure and properties of wood cement composites, and Adil Sharag Eldin, a Ph.D. candidate in Building Technology, Department of Architecture, who is studying the architectural, geometric, code and economic aspects of usable space in the roof cavity; defining the complexity, constructibility, costs of various conventional roof systems by surveying the Building Advisory Group, and is responsible for the developing eave and rake overhang details and accessories.

The thesis is divided into two parts. Part one covers the analysis and design of sandwich panels employed in various residential roof systems. The second part of the thesis deals with the development of a roof system, where a preliminary joining system is developed for panel type 3. The appendix includes computer programs utilized in analysis and design.

PART I

Analysis and Design of Residential Roof Sandwich Panels

The state of art in sandwich panel design and analysis is well advanced, and fully developed. Early theories were first developed for "stress-skin" construction, and have, over the years, been refined and extended for sandwich construction as applications for sandwich construction have grown: garage doors, aerospace, refrigeration, skis, building construction, furniture, etc. [Structural Plastics Design Manual, 84]. The objective of the first part of the thesis is to present the significant considerations of the structural analysis and design of flat sandwich panels, the problems associated with thermal and hygroscopic expansion and contraction, as well as examining the guidelines for design as set forth in the codes.

The analysis and design of sandwich panels are developed for the three structural systems shown in Figure 1-2.

1. Folded plate roof spanning between endwall gables (Figure 1-2-a).
 - a. Two options of joint connections at the fold line are examined.
 - i. Hinged
 - ii. Monolithic
 - b. Two options of panel to panel joints are examined.
 - i. Simple shear connection, with no moment-rotational rigidity provided.
 - ii. Monolithic joint with moment-rotational rigidity.
2. Sandwich panels spanning between the longitudinal wall (the eave) and the ridge beam, which spans between the two endwall gables (Figure 1-2-b).
3. Sandwich panels connected to the floor unit which acts as a cross tie to resist lateral thrust (Figure 1-2-c).

The faces of the panel are assumed to be made of the same material of equal

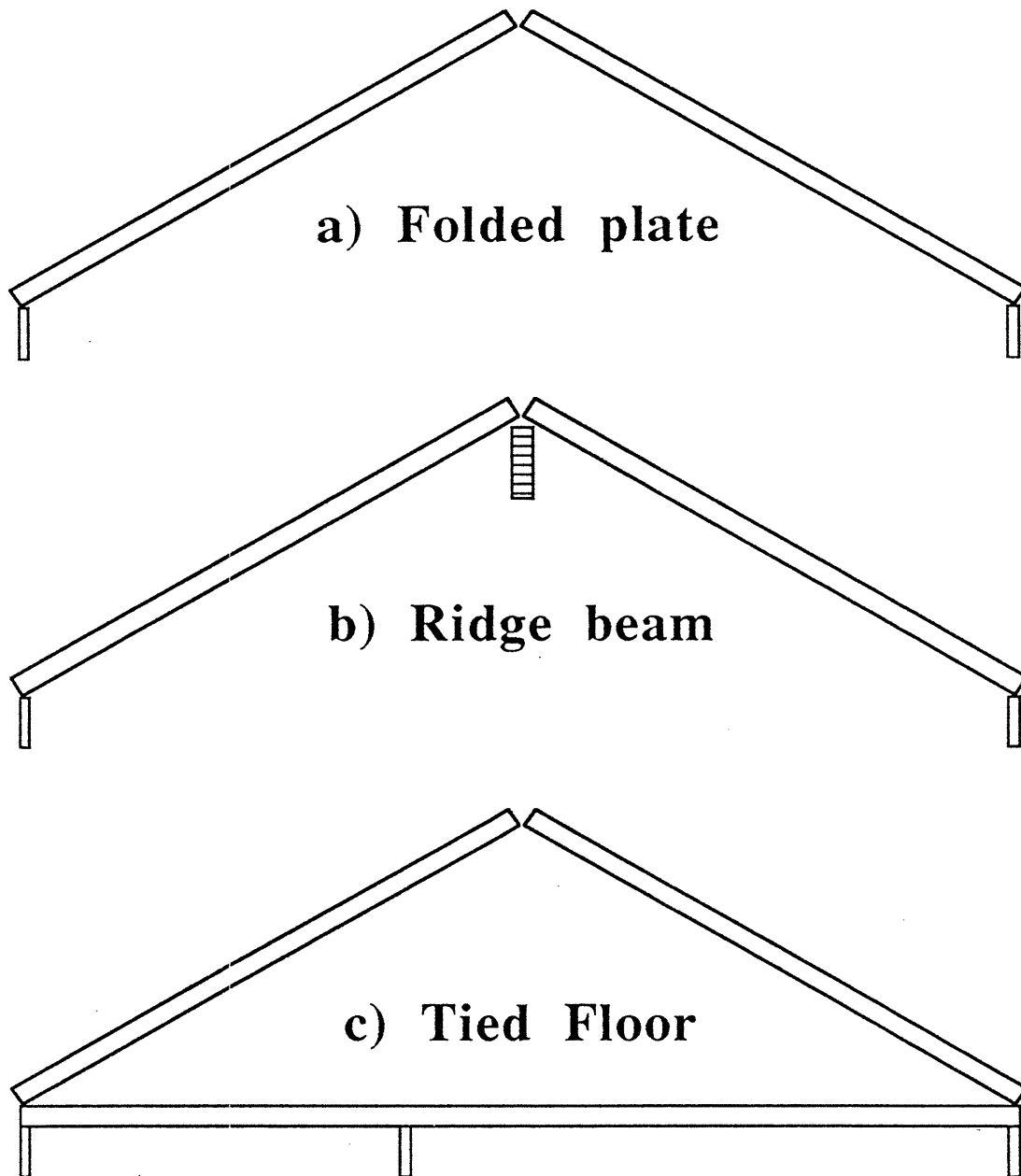

Figure 1-2: Roof Structural Systems

thickness. Panel faces are flat, not formed. Although formed faces have the attribute of decreasing shear deformations of panels in transverse bending, they will not be considered for the following reasons:

1. Joining of contoured faces to edge supports and panel to panel connections are difficult, especially when panels intersect at angles.
2. Contoured faces do not accommodate flat roof coverings.
3. Formed faces are aesthetically industrial in nature and relatively inflexible to customized and individualized roof textures.
4. Bending strength is developed in one direction only.
5. Thermal performance of the panel is reduced.

Chapter 2

Folded Plate Analysis

2.1 Review of Folded Plate Behavior

The folded plate design involves using the plates of a pitched roof as beams. Two plates in a single bay roof act as an inverted "V" to carry the vertical loads to the end supports at the gables. Folded plate action eliminates the need for trusses, ridge beams, collar ties or tension ties which typically carry the vertical loads.

The behavior of folded plates is conveniently separated into two independent actions. Loads applied normal to the roof surface are carried to the fold, eave and gable lines by the bending strength of the faces and the shear resistance of the core. This out-of-plane flexure is referred to as "slab" action. The longitudinal wall and the fold line at the ridge serve as lines of support for this "slab" action. Loads applied in the plane of the sandwich panel are carried through "plate" action, analogous to that of an inclined deep girder, laterally braced by the "plate" action of the adjacent panel and spanning between endwall gables. The key to grasping folded plate behavior is in understanding how the fold line, through "plate" action, acts as one line of support for "slab" action.

Figure 2-1 graphically depicts the folded plate behavior. The uniform projected load is distributed to the eave and fold line supports by the "slab" action of the panel elements. The eave line load is carried by the longitudinal wall. The ridge line load is resisted by forces developed in the plane of the roof panel. It is through this "plate" action that the ridge line load is carried in the plane of the roof panel to the gable line where the outward thrust is resolved by a tension tie and the downloads are distributed on corner posts.

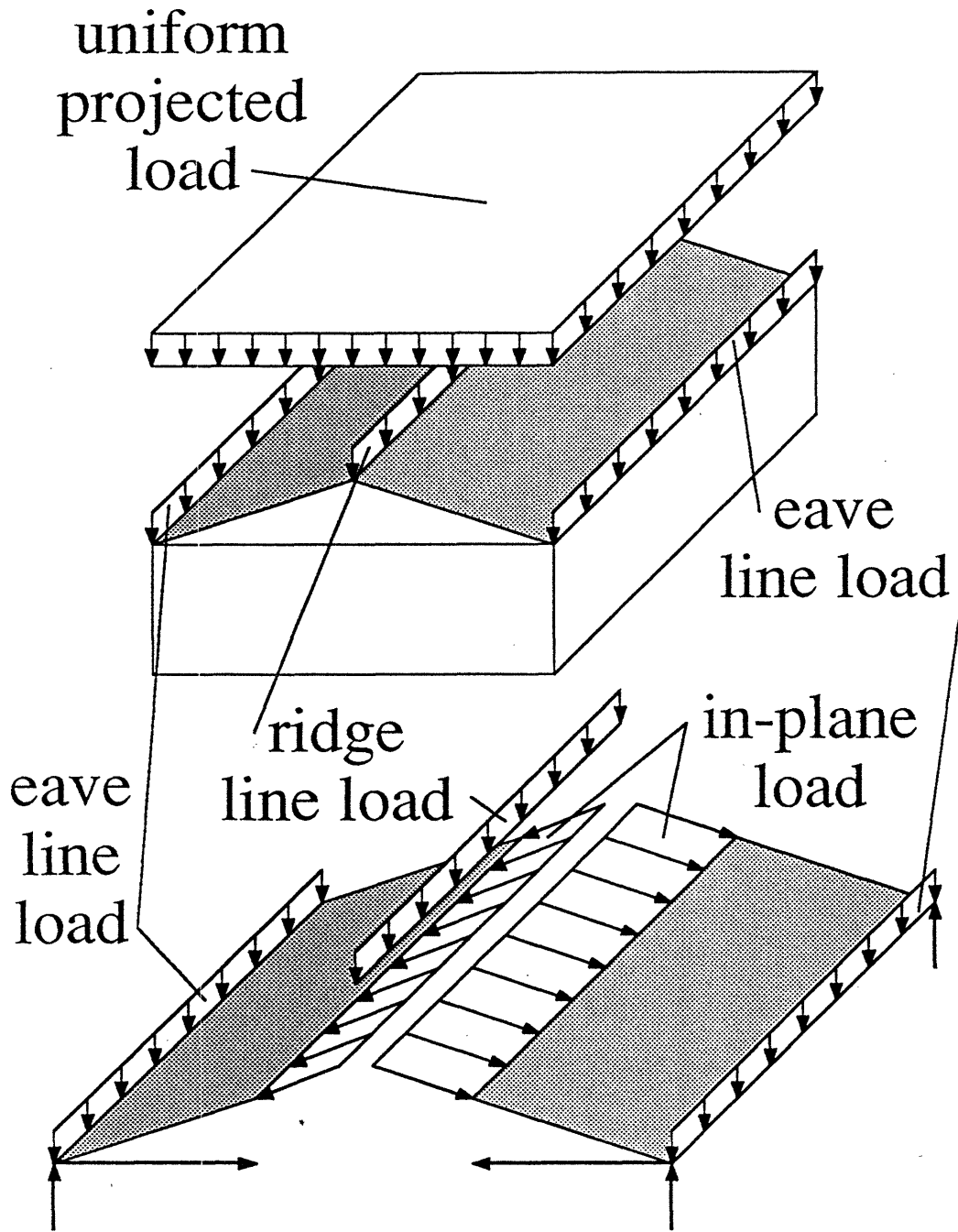

Figure 2-1: Schematic of Folded Plate Action

For small deflections, "slab" action carries only normal components of the load, while, "plate" action carries only the in-plane loads. Thus, a folded plate may be divided

into a "slab" structure offering no resistance to in-plane loads, and a "plate" structure offering no resistance to out-of-plane loads. Because of this, there is no difficulty in ensuring that the two structures have compatible deformations; they may be assumed to act independently.

The only interaction between the "slab" and "plate" structures is at the fold lines, where equal and opposite loads are imposed. If the "slab" and "plate" structures deform identically at the fold line, the assumption of compatible deformations is correct. It follows that, a folded plate with a hinged fold line may be regarded as a flexural "slab" simply supported along the fold line by a "plate" structure. Thus, a hinged folded plate is analogous to a slab with support movement along the longitudinal edges. This is because a displacement at the fold line will induce a displacement at the eave line. A monolithically joined folded plate differs from a hinged folded plate only in that the monolithic panel is rigidly fixed to one of its longitudinal supports, rather than simply supported, as in the hinged panel. Longitudinal support displacements result in a cord rotation of the panel, which is resisted by the flexural stiffness of the "slab".

2.2 Plate Action

In order to analyze "plate" action it is necessary to determine the loads transferred into the plane of the panel which spans as a deep girder between the endwall gables. Let P equal the total concentrated external load on a panel per unit length in the longitudinal direction.

$$P = [w_l \cos(\alpha) + w_d] H$$

where,

α = Angle between the folded plate and the horizontal (degrees).

w_l = Live load per unit horizontal projected area (p.s.i.).

w_d = Dead load per unit area of sandwich panel (p.s.i.).
 H = Slope distance between the fold line and the eave line (in.).

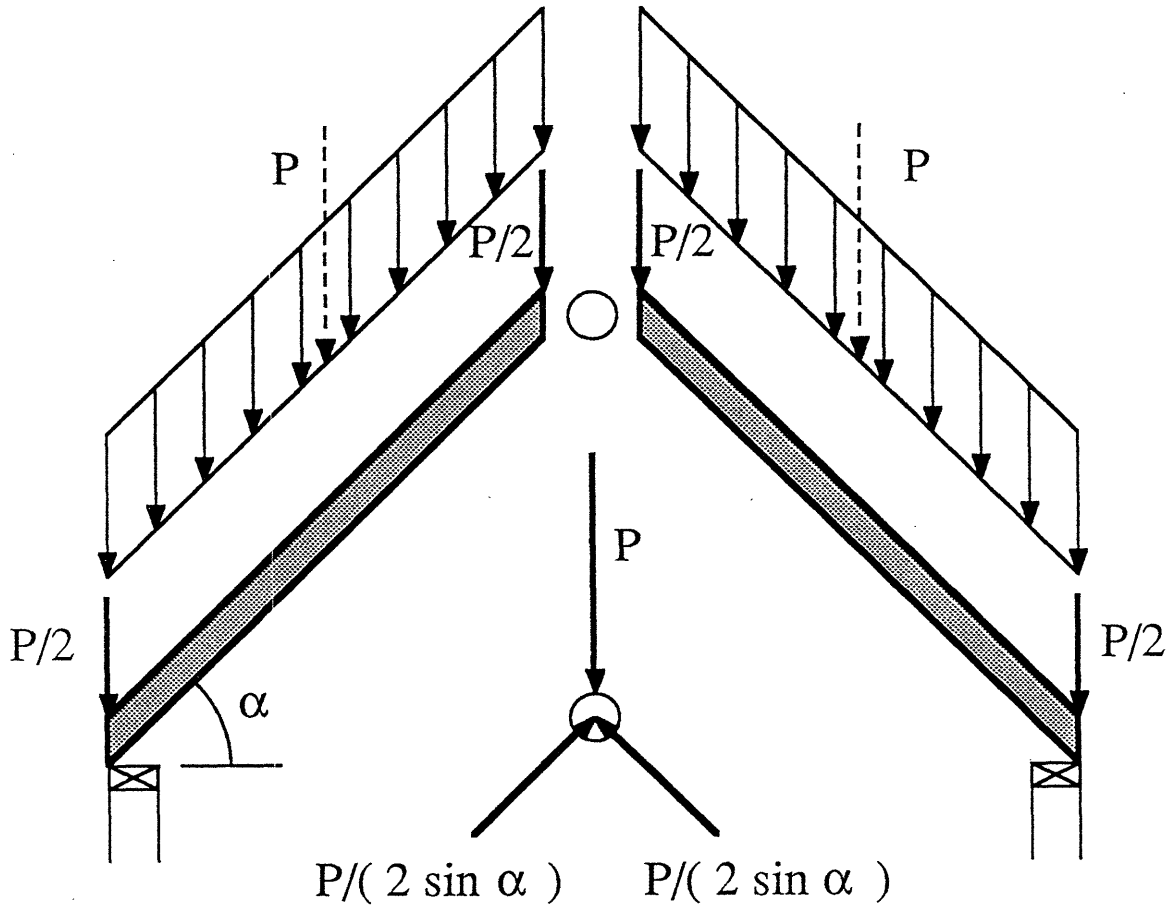

Figure 2-2: Force Diagram of Transverse Cross Section

The reaction from the panel elements, if conservatively represented as beam strips spanning between the eave and ridge line, is one-half the concentrated load P , or $P/2$ (see Figure 2-2). Edge reactions along the eave line are carried directly by the longitudinal edgwall. In a folded plate, the reactions along the ridge line are not resisted by a ridge beam or cross-tie floor unit. Therefore the only edge reaction inducing in-plane loads is the total reaction of P along the ridge line. This vertical edge reaction can be resisted only

by forces developed in the plane of the roof panel. A force resolution diagram (refer to Figure 2-2). of the in-plane load per unit length, W_p , gives:

$$W_p = \frac{P}{2 \sin(\alpha)} = \frac{[w_l \cos(\alpha) + w_d] H}{2 \sin(\alpha)}$$

The summation of this in-plane load per unit length along the ridge line results in an uniform in-plane load (see Figure 2-3).

$$W_p = P / (2 \sin \alpha) \text{ per unit length}$$

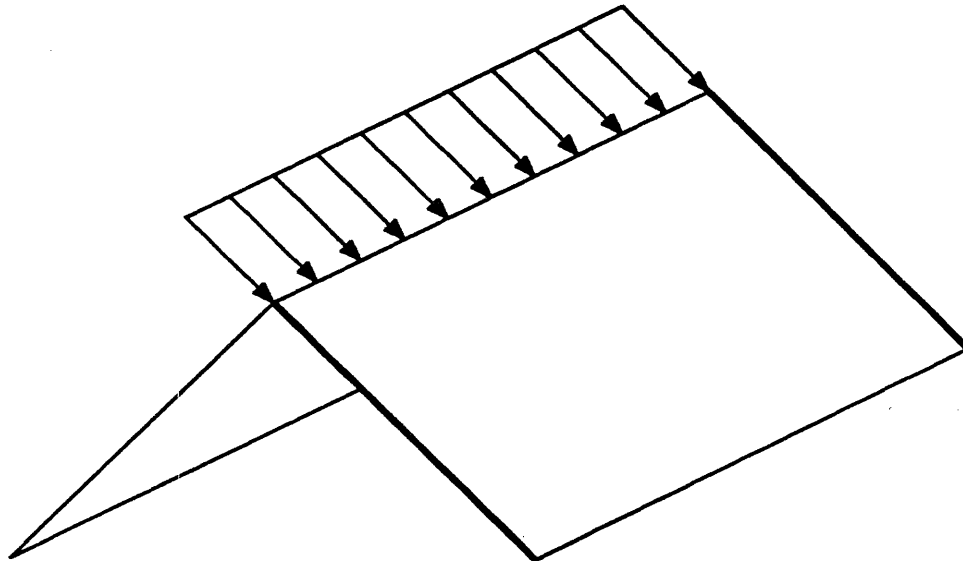

Figure 2-3: Uniform In-Plane Load

2.2.1 Plate Action Stresses

To carry in-plane loads, folded plate structures act as inclined girders. The "plate" structure can be analyzed as a girder beam simply supported at either end by the endwall gables, and subject to a uniform in-plane load. Both shear and flexural stresses arise from these in-plane loads (see Figure 2-4).

$$W_p = P / (2 \sin \alpha) \text{ per unit length}$$

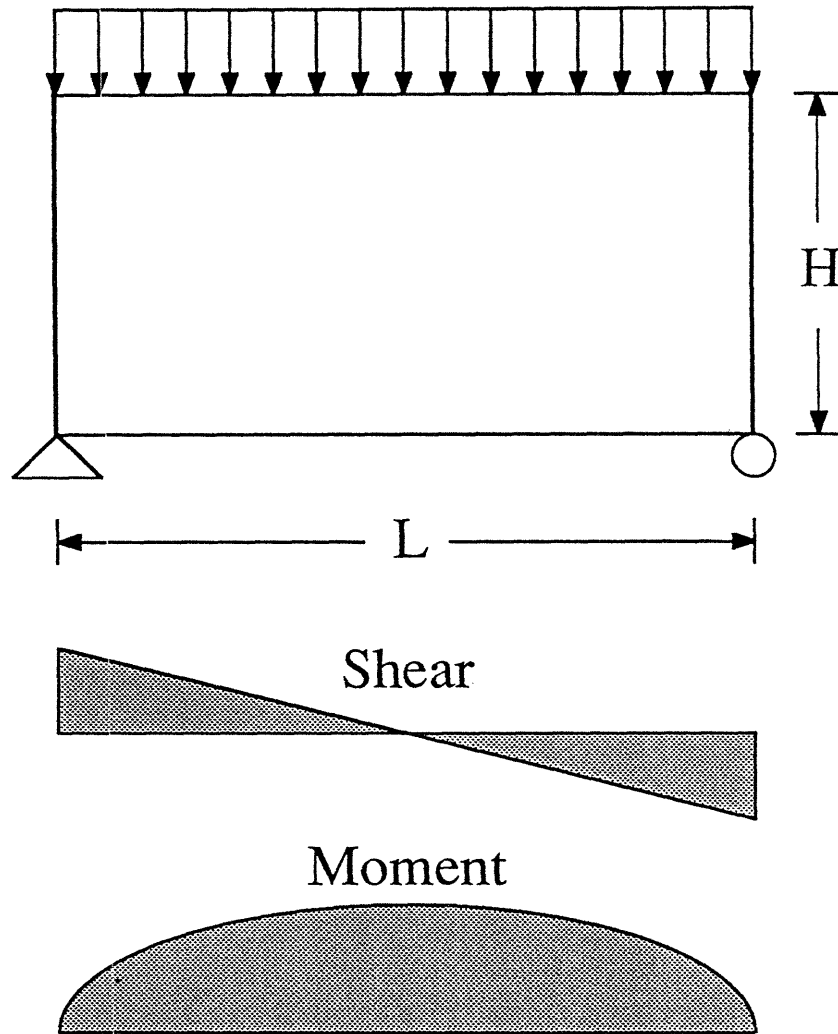

Figure 2-4: Deep Girder Beam

The flexural moments can be resisted by relying on the edge-wise bending of the panel faces. The "plate" structure may be analyzed with respect to its longitudinal neutral

axis with the overall section effective in bending, with plane sections remaining plane. This method of analysis generally proves adequate for most designs, but particular geometries may require modifications [Benjamin, 82]. For example:

1. In folded plate structures of sandwich construction, where the ratio of plate width to plate thickness is relatively high and compressive stresses in the face materials are near buckling failure, the entire transverse cross section of the sandwich faces may not be considered effective in the analysis.
2. For short folded plates, where the aspect ratio of length to height is less than 1.5, the assumption of a straight line stress distribution due to bending is no longer valid due to shear effects in a deep beam, and deep beam theory must be used [Benjamin, 82].

In long folded plates of typical sandwich construction, there is little deviation from the assumption of the overall section being effective in bending, with plane sections remaining plane. In the longitudinal direction, the normal bending stresses are proportional to the moment; the maximum bending stresses occur at the midspan. The bending stresses also vary linearly in the transverse direction, from zero at the neutral axis to a maximum value a distance of $H/2$ from the neutral axis. The maximum bending stress in the face in the longitudinal direction is:

$$(\sigma_{fp})_{max} = \frac{w_p L^2 H}{16 I_p}$$

where,

I_p = Transformed moment of inertia of transverse section of sandwich panel.

$$= [2 (t) + (E_{cp} / E_{fp}) c] H^3 / 12$$

t = Thickness of the faces of the sandwich panel (in.).

E_{cp} = Young's Modulus of core material in longitudinal direction (p.s.i.).

E_{fp} = Young's Modulus of face material in longitudinal direction (p.s.i.).

c = Thickness of sandwich core (in.).

The maximum bending stress in the core in the longitudinal direction is:

$$(\sigma_{cp})_{max} = \frac{E_{cp}}{E_{fp}} [(\sigma_{fp})_{max}]$$

The resulting flexural stresses are critical, especially the maximum tension forces at the midspan region of the folded plate. Fastening thin faces of a sandwich panel subjected to high tension loads is a difficult problem. Moreover, an economic joining system would require the variability in fastening strength to match the varying flexural stresses, although this would produce additional complexity in the construction process.

The addition of longitudinal line members at the fold and eave line solves the above problems. Furthermore, in the case of dormers and turned gables, where openings are cut into the folded plate, it becomes mandatory that line members be added to increase the transverse sectional moment of inertia.

Longitudinal line members at the ridge and eave act as I-beam flanges to resist the parabolic moment distribution. The eave line carries tension loads. The maximum axial stress in the line member in the longitudinal direction is calculated from beam theory assuming that only the longitudinal line members contribute to the moment of inertia:

$$(\sigma_e)_{max} = \frac{w_p L^2}{8 A_e H}$$

The required cross-sectional area of the longitudinal eave line member, A_e , to carry these axial loads can be estimated on the basis of strength requirements, by the formula:

$$A_e = \frac{w_p L^2}{8 \sigma_{all} H}$$

where,

σ_{all} = Allowable unit stress (p.s.i.).

The fold line carries compressional loads. The required area of the longitudinal fold line member is twice that required for the eave line member.

The diaphragm action of the panels carry the shear loads to the gable line. The

shear varies linearly from the maximum value at the gable lines to a minimum value at the midspan. The maximum shear value at the gable line due to a uniformly loaded folded plate is:

$$(Q_p)_{max} = W_p(L/2)$$

The shear at the midspan would equal zero for the load case of a uniform in-plane load over the complete length of the "plate", however, an unbalanced uniform load over one-half the "plate" span results in a non-zero shear value. The minimum shear value at the midspan, due to a uniform load over one half of the folded plate span is:

$$(Q_p)_{min} = W_p(L/8)$$

The longitudinal line members, or flanges, can be assumed as concentrated at the edges of the plate diaphragm. The overall depth of the section, H , is very large when compared to the depth of the longitudinal line member. This assumption yields an essentially uniform shear stress distribution throughout the depth of the panel. All regions of the face act effectively as one homogeneous web in resisting these shear forces. Hence the maximum in-plane shear stress in the faces at the gable lines can be found as:

$$(\tau_{fp})_{max} = \frac{W_p L}{2 A_p}$$

where,

L = Span between end walls in the longitudinal direction.

A_p = Transformed transverse cross sectional area of sandwich panel.

$$= [2(t) + (G_{cp}/G_f) c] H$$

t = Thickness of the faces of the sandwich panel (in.).

The maximum in-plane shear stress in the core is:

$$(\tau_{cp})_{max} = \frac{G_{cp}}{G_f} [(\tau_{fp})_{max}]$$

where,

G_{cp} = In-plane shear modulus of core material (p.s.i.).

G_f = In-plane shear modulus of face material (p.s.i.).

If no longitudinal line member is incorporated into the folded plate, the shear stress distribution is no longer uniform, but parabolic. The shear stresses must be increased by a factor of 3/2.

2.2.2 Plate Action Deflections

The deflection of the roof system is of primary concern from both the aesthetic viewpoint and the possibility of structural interference with secondary building systems. The most stringent code requires that vertical ridge deflections be limited to $L/240$ for live loads only (controlling case) , and to $L/180$ for live and dead loads. Lateral deflections along the longitudinal edge wall are limited to $L/240$ for 2X4 construction [U.B.C., 88].

The method of analysis is similar in concept to that used in determining truss deflections. The folded plate structure is conceptually separated at the fold line and the in-plane "plate" deformations are calculated. The panel edges at the fold line are then brought back into coincidence and the vertical deflection of the fold line is determined by the use of a Williot diagram (Figure 2-5). The horizontal eave deflections are found from simple geometry.

The in-plane deflection of the "plate" is the sum of four parts: shear deflection of the "plate" (δ_s), seam slip deflections (δ_{ss}), eave line member splice deflections (δ_e), and flexural deflection (δ_f) of the "plate" acting as a deep beam girder.

In-plane "plate" deformation due to shear can be found by established methods. The faces in the transverse cross section act as one homogeneous web. The midspan shear deflection, δ_s , is:

$$\delta_s = \frac{w_p L^2}{8 A_p G_f}$$

Additional shear deflections occur due to the seam slip at the joints between individual panel elements, and are estimated using an empirical relationship between applied shear and the resulting seam slip. The total midspan deflection due to seam slip, δ_{ss} , can be found by summing the seam slip deflections at each joint between the support and the midspan. For a "plate" under a uniform load, shear decreases linearly from the support to the midspan; the principal contribution to the overall seam slip occurs at the joints nearest to the endwall gable supports.

Deflections occur due to the slip at the splice between eave line members. This deflection is estimated using an empirical relationship between applied tension and the resulting slip in the tension splice. The total midspan deflection due to splice deflections, δ_e , can be found by summing the deflections at each splice in the eave line member multiplied by H and divided by the distance of the splice from the gable line. For a "plate" under a uniform load, tension decreases with the parabolic moment distribution which is a maximum at the midspan; the principal contribution to the overall eave line deflection occurs at the splices nearest to the midspan.

If no longitudinal line members are incorporated into the panel, the flexural deflection, δ_f , is calculated from beam theory assuming plane sections remain plane. For a uniformly loaded simple span, the midspan flexural deflection is:

$$\delta_f = \frac{5 w_p L^4}{384 E_{fp} I_p}$$

In the case of no longitudinal line members, the ratio of shear to flexural deflections (neglecting seam slip) is given by:

$$\frac{\delta_s}{\delta_f} = \frac{w_p L^2}{8 A_p G_f} \frac{384 E_{fp} I_p}{5 w_p L^4}$$

for an isotropic panel with anti-plane core and faces of equal thickness. Assuming a Poisson's ratio of 1/3 for the face material and using the relationship between the two moduli:

$$G_f = \frac{E_{fp}}{2(1+\nu_f)}$$

where,

ν_f = Poisson's ratio of the face material.

The ratio of shear to flexural deflections, neglecting the core, becomes:

$$\frac{\delta_s}{\delta_f} = 2.08(H/L)^2$$

For the aspect ratio of the *Brentwood* home ($L/H = 2.67$) flexural deflections are 29% of the shear deflections. This calculation of flexural deflections does not include the additional slip between panel to panel joints. If panel to panel joints are glued, the slip is non-existent.

The flexural deflection, δ_p , of a folded plate using longitudinal line members is calculated from beam theory assuming that only the longitudinal line members contribute to the moment of inertia. For a uniformly loaded simple span, the midspan deflection is:

$$\delta_f = \frac{5W_p L^4}{384 E_c I_p}$$

where,

$$I_p = A_c H^2/2$$

The true deflection surface of a folded plate is complicated, since the plates of the

roof must warp to achieve compatible deflections, and rotations. In a single bay folded plate, the ridge deflects downward and the walls outward. The effect of "plate" deformations on the vertical ridge deflection and lateral eave deflection can be determined geometrically. Using a Williot diagram (Figure 2-5) the vertical ridge deflection is:

$$\delta_v = \frac{\delta_s + \delta_{ss} + \delta_f}{\sin(\alpha)}$$

From geometry the horizontal eave deflection is (Figure 2-5):

$$\delta_h = (H^2 - (D - \delta_v)^2)^{1/2} - B$$

where,

D = Vertical projected distance between fold line and eave line (in.).

B = Horizontal projected distance between fold line and eave line (in.).

A simplified expression for horizontal eave deflections utilizing linear geometry, which assumes small angle rotations, is:

$$\delta_h = \delta_v(D/B)$$

It should be noted that any longitudinal edge wall deflections or settlements decrease the horizontal eave deflections due to the "plate" deformations.

2.3 Slab Action

"Slab" action depends on the out-of-plane load per unit area of sandwich panel.

$$w_s = [w_l \cos(\alpha) + w_d] \cos(\alpha)$$

The "slab" action of the panel under normal loads can be analyzed in either one-way or two-way action. In one-way action, a representational beam spanning between eave and ridge line is analyzed. Alternatively, two way slab behavior considers one-half of the roof as a continuous monolithic slab, assuming a moment rigid joint between panel elements.

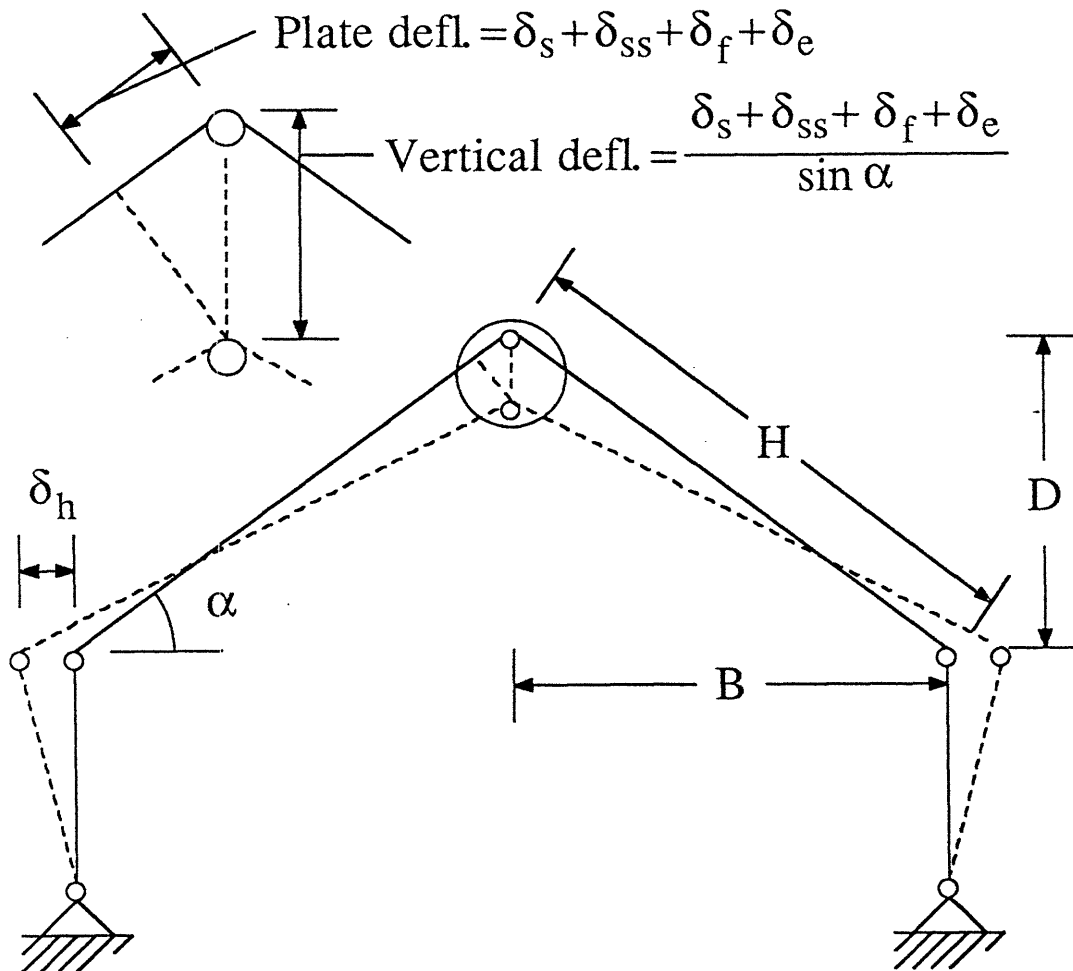

Figure 2-5: Geometry of Deflections

Two-way "slab" action is calculated analytically by the use of classical plate theory or numerically by a matrix formulation, such as the finite element method.

If the span of a monolithic panel, L , is large compared to its slope dimension, H , it can be analyzed by considering the behavior of a representational beam spanning between the eave and the ridge. As the ratio of L/H is reduced there is a transition from one-way beam action to two-way plate action.

Although it is feasible to construct an effective monolithic joint between panels in situ, the benefit gained from the added costs must be examined. One-way and two-way slab action are compared in Table 1-0 which shows the advantage to be gained from the use of monolithic panel joints in folded plates. In general, the panel design is controlled by the deflection criteria. For short folded plates, the increased stiffness to be gained by the monolithic joint system acting in two-way slab action is substantial. A folded plate with an aspect ratio of length to height of 2.0 has a 22% reduction in deflections with monolithic panel joints over joints designed for shear capacity only. For long folded plates the value added by moment rigid panel to panel connections is not significant. Timoshenko (1959) suggests that for $L/H = 3$ the difference between the two methods of analysis in deflections is 6%; in moments it is 5% (Table). Weighing these small reductions in moments and deflections against the added cost and difficulty of assuring a moment rigid connection between panel elements in situ, and the added complexity involved in calculations, value engineering leads to the abandonment of the two-way concept. If the concept of short folded plates is to be developed, the costs, deterioration over time, and quality control of monolithic panel joining systems must be researched. If the joining system is less than perfectly monolithic, the behavior of the folded plate deviates from ideal two-way slab action. The finite element method is an effective tool for studying this intermediate behavior. The boundary conditions between panels can be input into the model.

Odd shaped roof panels, however, may be analyzed with greater accuracy, and, hence, be designed with greater economy by two-way analysis. If the classical method of plate analysis is chosen, a great number of exact and approximate solutions are readily available for plates of various shapes. The finite element method can easily accommodate odd shapes. One could assume, however, that the panel sections would not be optimized for each panel shape, but remain the same section throughout the roof. Changing panel

sections throughout the roof would be uneconomical from a manufacturing standpoint and create problems in the joining system.

L/H	w'_{max}	$(M_x)_{max}$	$(M_y)_{max}$	$(Q_x)_{max}$	$(Q_y)_{max}$	$(V_x)_{max}$	$(V_y)_{max}$	R
1.0	31.1	38.3	127.7	67.6	90.9	84.0	84.0	68.4
1.1	37.3	44.3	131.5	72.0	93.3	88.0	88.0	73.7
1.2	43.3	50.2	133.6	76.0	94.9	91.0	90.6	77.9
1.3	49.0	55.5	134.1	79.4	96.0	93.6	92.8	83.2
1.4	54.1	60.4	133.9	82.2	97.0	95.6	94.2	87.4
1.5	59.3	65.0	132.8	84.8	97.6	97.2	96.0	89.5
1.6	63.7	69.0	131.2	87.0	98.1	98.2	97.0	90.5
1.7	67.8	72.6	129.6	88.8	98.7	99.2	97.6	92.6
1.8	71.5	75.8	127.7	90.4	98.9	99.8	98.2	94.7
1.9	74.8	78.8	125.6	91.8	99.2	100.4	98.8	95.8
2.0	77.8	81.4	123.7	93.0	99.5	100.6	99.2	96.8
3.0	93.9	95.1	108.3	98.6	100.0	101.0	99.6	97.9
4.0	98.5	98.8	102.4	99.6	100.0	100.4	100.0	98.9
5.0	99.6	99.7	100.0	100.0	100.0	100.2	100.0	100.0
∞	100.0	100.0	100.0	100.0	100.0	100.0	100.0	100.0

2.3.1 Influence of Support Connections

The analysis of folded plates is dependent on the type of connection between the panel and supports. Ideally, the relative motion between the support and panel is restrained against horizontal and vertical movement, but angular rotation is allowed. For the hinged joint at the fold line, there is little deviation from this assumption. If the site connections at the eave and gable lines are simply bolted one may assume that they have little moment-rotational rigidity and act as a continuous hinge. Rotational stiffness at these particular supports would have the unfavorable result of imposing an end moment on the axially loaded 2X4 studs or panelized wall, disastrously affecting deflections and critical buckling strength. The connections along the longitudinal edge wall, and the end

gables must be designed so as to allow for this rotational flexibility. After deployment of the folded panel, there exists the possibility of rigidly fixing the hinged fold line in situ. This could be achieved by the use of metal plates, epoxy adhesives, or keyed joints. The effect of a monolithic joint at the fold line will be explored in Section 2.3.2.3 and Section 2.3.3.1.

2.3.2 One-Way Slab Action

The sandwich beam consist of two stiff faces of thickness t , bonded to either side of a low density core of thickness c . The overall depth of the beam is h ; the width of beam is b . If the beam is wide ($b \gg c$) the lateral expansions and contractions in the longitudinal direction are restricted by the shear resistance of the face and core; it is reasonable to assume that the strains in the longitudinal direction are zero. The ratio of stress to strain in the transverse direction is therefore $E/(1-\nu^2)$ for both membrane and local bending stresses. This value replaces E in all slab action equations [Allen, 69].

The flexural rigidity of a sandwich is the sum of the flexural rigidity of the face and core, measured about the centroidal axes:

$$ei = \frac{E_f b t^3}{6} + \frac{E_f b t d^2}{2} + \frac{E_c b c^3}{12}$$

where

b = Width of panel beam (in.).

c = Thickness of sandwich core (in.).

h = Overall depth of sandwich panel (in.).

d = Distance between the centerlines of the two sandwich faces (in.).

$$= c + t$$

E_c = Young's Modulus of core material in transverse direction (p.s.i.).

E_f = Young's Modulus of face material in transverse direction (p.s.i.).

The first term in the flexural rigidity equation dominates. The second term amounts to less than 1% of the first if:

$$3(d/t)^2 > 100$$

A ratio of $d/t > 5.77$ satisfies this condition. Thick, compliant faces may not pass this criteria.

The third term is less than 1% of first term if:

$$6 \frac{E_f t}{E_c c} (d/c)^2 > 100$$

There is no guarantee that this limiting condition will be satisfied for all possible material combinations.

2.3.2.1 One-Way Slab Action Stresses

The stresses in the face and core may be determined by ordinary bending theory modified to account for the composite nature of the sandwich cross section. The maximum stress in the face and core are, respectively:

$$\sigma_{(f)max} = \frac{w_s H^2 E_f h}{8 ei} \frac{1}{2}$$
$$\sigma_{(c)max} = \frac{w_s H^2 E_c c}{8 ei} \frac{1}{2}$$

The shear stress in the core is given by:

$$\tau_c = \frac{w_s H}{2 ei} [E_f t d/2 + E_c c^2/8]$$

If the sandwich panel is to be employed in a folded plate, the face thickness may be determined by the strength requirement of the shear diaphragm, $(\tau_{fp})_{max}$.

2.3.2.2 One-Way Slab Action Deflections

In general, the displacements of a statically determinant system can be found by superimposing the bending and shearing deflections. For a simply supported beam of span H , under a uniformly distributed load of w_s , the maximum bending deflection is:

$$\delta_1 = \frac{5 w_s H^4}{384 e i}$$

The maximum shear deflection is:

$$\delta_2 = \frac{w_s H^2}{8 A G_c}$$

where,

$$A = \frac{b d^2}{c} \approx b c$$

G_c = Shear modulus of core material in transverse direction (p.s.i.).

The final maximum deflection is:

$$w_{max} = \delta_1 + \delta_2$$

2.3.2.3 One-Way Monolithic Ridge Joint

Should the fold line be made monolithic, one way slab behavior is modified. Due to a rotationally rigid joint at one end support, the flexural deflections are reduced by 58% when compared to a hinged fold line. The maximum shear stress is increased by 25%. While the maximum moment remains at the same value as that for a hinged fold line, the maximum moment occurs at the fold line. The in-situ connection of a monolithic joint at the fold line capable of resisting this maximum moment is feasible, but, the benefit of increased panel stiffness must be weighed against the difficulty of assuring joint quality, the fixity of the joint over time, and the cost of fixing the joint. In addition there are significant penalties with respect to thermal and hygroscopic behavior which are related to the length of panel span. A monolithic fold line doubles the eave to ridge panel span of a hinged fold line. Refer to Chapter 5 for details.

2.3.3 Two-Way Slab Action

The analysis of two-way "slab" action assumes the following: These are:

1. Due to the structural and aesthetic constraints on deflections, it can be assumed that deflections will be less than the thickness of the sandwich panel. Hence, simplified formula for curvature is assumed valid, and small deflection theory applies.
2. Bending moments, twisting moments, reactions, and shears can be approximately determined using classical plate theory by neglecting the effect of shear deformations in the sandwich core. Displacements, however, must be corrected by a shear factor to account for the deformations of the sandwich core in shear.
3. The edge support displacements of the "slab" due to in-plane "plate" deformations can be considered negligible.
4. No face wrinkling or dimpling occurs in the panel (Must be checked in the design).
5. The boundary conditions at the supports are determined by the type of connection employed.
6. Butt joints between panel elements are assumed to have a moment-rotational rigidity and transfer shear capacity comparable to the panel itself.

Consider an isotropic sandwich panel with simple bolted support connections, monolithic joints between panels, and a hinged fold line. The out of plane "slab" action can be determined by considering plate $QRST$ (see Figure 2-6) as simply supported along all four edges). The bending moments, twisting moments, and reactions can be approximated using ordinary bending theory which neglects shear deformations. Reissner [1949] and Ericksen [1958] have proven this approach valid with specific cases. As the method of analysis, the small deflection plate theory of Levy [Timoshenko et al., 59] was chosen for its rapid convergence, and suitability for hand calculations.

The moments M_x and M_y per unit length can be calculated by the equations given below:

$$M_x = \frac{4 w_s L^2}{\pi^3} \sum_{m=1,3,5,\dots}^{\infty} \frac{1}{m^3} \left[1 - \frac{(1-\nu_f) \alpha_m \tanh \alpha_m}{\alpha_m + 2} \frac{1}{2 \cosh \alpha_m} \cosh y_m \right]$$

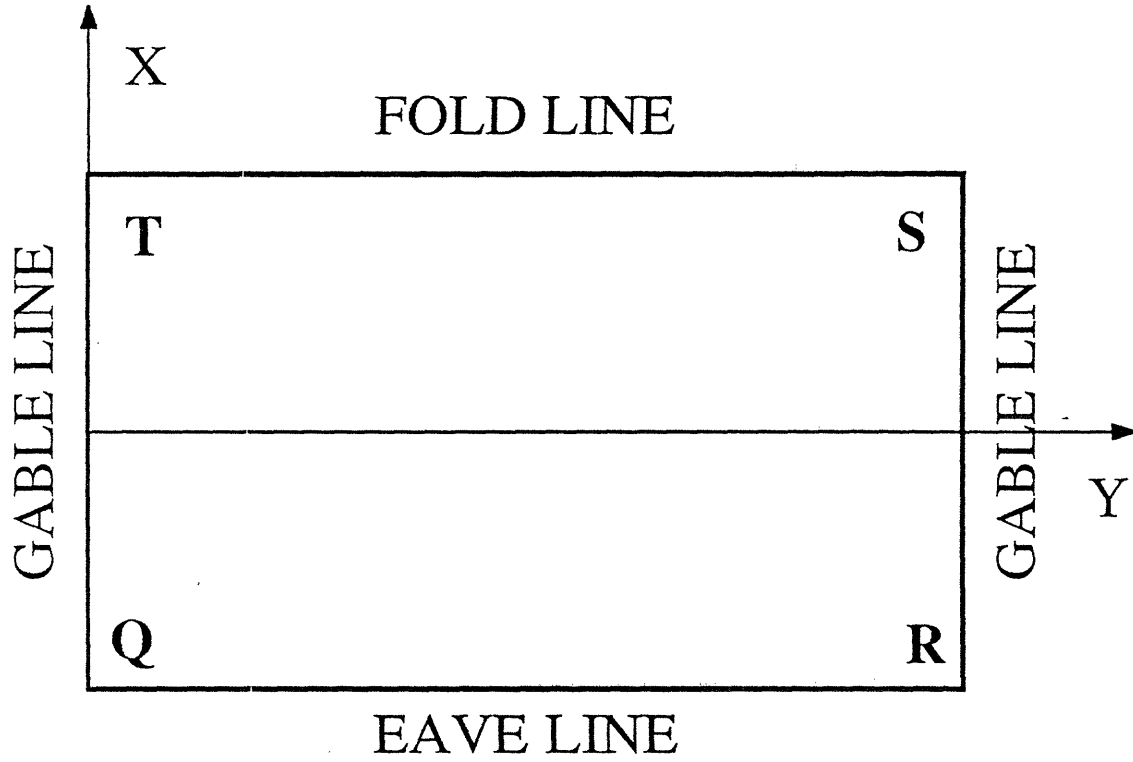

Figure 2-6: Plan View of Folded Plate Panel

$$\begin{aligned}
 & + \frac{(1-\nu_f)\alpha_m}{2 \cosh \alpha_m} \frac{2y}{H} \sinh y_m] \sin x_m \\
 M_y = & \frac{4w_s L^2}{\pi^3} \sum_{m=1,3,5,\dots}^{\infty} \frac{1}{m^3} \left[\nu_f - \frac{(\nu_f-1)\alpha_m \tanh \alpha_m + 2\nu_f}{2 \cosh \alpha_m} \cosh y_m \right. \\
 & \left. + (\nu_f-1) \frac{\alpha_m}{2 \cosh \alpha_m} \frac{2y}{H} \sinh y_m] \sin x_m
 \end{aligned}$$

Where,

$$\alpha_m = \frac{m \pi H}{2L}$$

$$x_m = \frac{m \pi x}{L}$$

$$y_m = \frac{m \pi y}{L}$$

The shearing forces per unit length are:

$$Q_x = \frac{w_s(L-2x)}{2} - 2 \pi^3 w_s L \sum_{m=1,3,5,\dots}^{\infty} m^3 B_m \cosh y_m \cos x_m$$

$$Q_y = -2 \pi^3 w_s L \sum_{m=1,3,5,\dots}^{\infty} m^3 B_m \sinh y_m \sin x_m$$

where,

$$B_m = \frac{2}{\pi^5 m^5 \cosh \alpha_m}$$

The reaction along side $x = 0$ is given by the expression:

$$V_x = \frac{w_s L}{2} - \frac{4 w_s L}{\pi^2} \sum_{m=1,3,5,\dots}^{\infty} \frac{\cosh y_m}{m^2 \cosh \alpha_m} + \frac{2(1-\nu\beta) w_s L}{\pi^2} \sum_{m=1,3,5,\dots}^{\infty} \frac{1}{m^2 \cosh^2 \alpha_m} (\alpha_m \sinh \alpha_m \cosh y_m - y_m \cosh \alpha_m \sinh y_m)$$

The reactive forces due to the twisting moments, M_{xy} , are concentrated at the corners of the folded plate panel. The reactions are directed downward to prevent the corners of the panel from rising.

$$R = \frac{4(1-\nu\beta) w_s L^2}{\pi^3} \sum_{m=1,3,5,\dots}^{\infty} \frac{1}{m^3 \cosh \alpha_m} [(1 + \alpha_m \tanh \alpha_m) \sinh \alpha_m - \alpha_m \cosh \alpha_m]$$

The deflected surface, neglecting shear deformations, is given by:

$$w' = \frac{4 w_s L^4}{\pi^5 e i} \sum_{m=1,3,5,\dots}^{\infty} \frac{1}{m^5} \left(1 - \frac{\alpha_m \tanh \alpha_m + 2}{2 \cosh \alpha_m} \cosh \frac{2\alpha_m y}{H} + \frac{\alpha_m}{2 \cosh \alpha_m} \frac{2y}{H} \sinh \frac{2\alpha_m y}{H} \right) \sin x_m$$

The expression for the maximum deflection, neglecting shear deformations, is:

$$w'_{max} = \frac{4 w_s L^4}{\pi^5 e i} \sum_{m=1,3,5,\dots}^{\infty} \frac{(-1)^{(m-1)/2}}{m^5} \left(1 - \frac{\alpha_m \tanh \alpha_m + 2}{2 \cosh \alpha_m} \right)$$

The above deflection equations are formulated with the assumption that the shear modulus of the core is infinite. Shear deformations have been ignored. March (1955) has shown that if shear deformations have been neglected, the deflection of the panel, including the effect of shear deformation, can be approximated as:

$$w_{max} = w'_{max}(1+\eta)$$

where,

w'_{max} = Maximum deflection of the panel neglecting shear deformations in the core (in.).
 η = A correction factor.

The correction factor is:

$$\eta = \frac{cr}{k'}$$

In the case of a rectangular panel with all four edges simply supported:

$$r = \frac{\pi^2}{2\lambda H^2} (E_f L^2/H^2 + E_{fp} H^2/L^2 + 2A)$$

and

$$k' = G_c (1 + L^2/H^2)$$

and

$$\lambda = (1 - \nu_f^2)$$

$$A = E_f \nu_f + 2\lambda G_f$$

2.3.3.1 Two-Way Monolithic Ridge Joint

Should the fold line be made monolithic, the slab must be analyzed as simply supported along three edges and rigidly fixed along the fourth edge ST . The slab analysis is then calculated in two steps [Benjamin, 82]:

1. Slab is simply supported on all four edges.
2. Edge ST is subjected to moment M_y , such that the slope at $y = H/2$ due to the external loading is equal and opposite to the slope at the same edge due to M_y .

$$\left(\frac{\partial w'}{\partial y} \right) \Big|_{y=H/2} = - \left(\frac{\partial w''}{\partial y} \right) \Big|_{y=H/2}$$

The first step is carried out using the analysis of the previous section 2.3.3. The equations for second step follow:

The moment M_y applied along the edge ST can be expressed as:

$$(M_y)_{y=H/2} = \sum_{m=1,3,5,\dots}^{\infty} E_m \sin x_m$$

The value of E_m is given by:

$$E_m = \frac{-8 w_s L^2}{\pi^3 m^3} \frac{\alpha_m - \tanh \alpha_m (1 + \alpha_m \tanh \alpha_m)}{(\alpha_m \tanh^2 \alpha_m - \tanh \alpha_m + \alpha_m \coth^2 \alpha_m - \coth \alpha_m - 2 \alpha_m)}$$

The expression for the deflection is then:

$$w'' = \frac{L^2}{4 \pi^2 e_i} \sum_{m=1,3,5,\dots}^{\infty} \frac{E_m \sin x_m}{m^2} \\ \times [\cosh^{-1} \alpha_m (\alpha_m \tanh \alpha_m \cosh y_m - y_m \sinh y_m) \\ + \sinh^{-1} \alpha_m (\alpha_m \coth \alpha_m \sinh y_m - y_m \cosh y_m)]$$

2.3.3.2 Short Folded Plates

Short folded plates deviate from the assumptions used in analyzing long folded plates. For long folded plates the reactions along the eave line are nearly constant at $P/2$, except in the vicinity of the endwall gables. In short folded plates the distribution of reactions along the fold line shows more variation, and consequently, the variation in edge reaction effects the in-plane loads of the folded "plate". Furthermore, the moment rigidity of panel to panel connections effects the variation in edge reactions. Short folded plate behavior is also influenced by the deep beam behavior of low aspect ratios, L/H . While these effects are difficult to quantify in a closed form solution, a finite element investigation would accurately predict the physical response.

2.3.4 Face Wrinkling

The compression face of a sandwich beam with an isotropic core is examined for face wrinkling utilizing a method described by Allen [69]. The mode of failure is represented in Figure 2-7. The wrinkling is assumed to occur only in the compression face since the tensile face remains flat. The wrinkling stress is given by:

$$\sigma_w = B_1 (E_f E_c G_c)^{1/3}$$

For practical sandwich panels with thin faces the value of B_1 may be conservatively assumed as 0.5. The face thickness obtained for face wrinkling is then compared to the existing value for the face thickness.

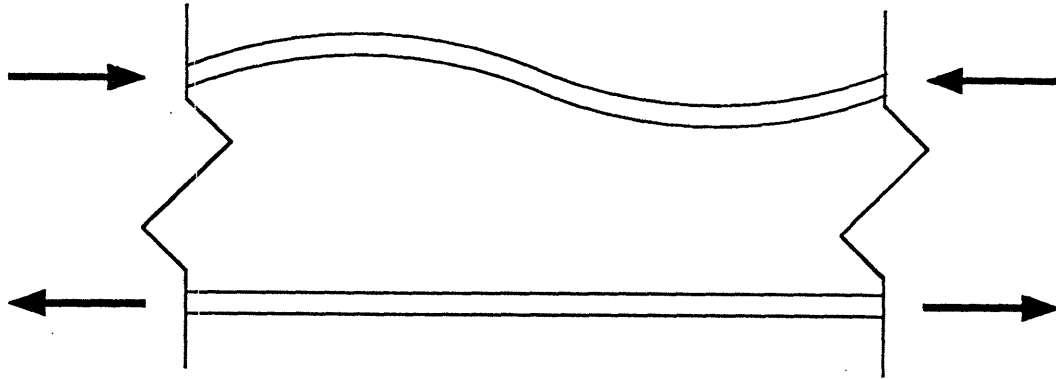

Figure 2-7: Wrinkling of the Compression Face (after Allen 1969)

2.4 Roof Complexities

The folded plate concept experiences some construction difficulties when complex roof shapes are incorporated into the structure. Generally the most difficult aspect is to suspend the panel element pieces in their aligned position so that they can be joined together to develop folded plate behavior. Not until all panel to panel joints and edge supports are connected will the folded plate develop any rigidity. Puncturing of the roof diaphragm can interfere with folded plate behavior.

2.4.1 Roof Openings

Placement of skylights, turned gables, dormers, and other openings in a folded plate are much more critical than in normal residential roof construction. It becomes necessary to transfer shear as well as bending stresses through reinforcement around openings cut in the roof diaphragm. Bending loads can be transferred to adjacent framing panels through structural headers. These structural members can be inserted within the depth of the panel core. Shear stresses are carried around openings by the placement of strut collectors at the

edge of the cut outs. The general problem of providing natural light, ceiling clearance, and ventilation can be solved through the following design recommendations:

1. The triangular areas of the endwall gable at either end of the span may be opened up to fenestration.
2. Openings may be cut in the panels near the center of the folded plate where shear stresses are at a minimum.

It is recommended that complex roof forms, such as turned gables, and dormers be positioned so as to line up with the center of the maximum in-plane moment, corresponding to the point of zero shear. To align the centerline of the turned gable or dormer with the midspan of the folded plate, a long folded plate may be segmented into two short folded plates with an intermediate diaphragm support. Typically, the shape of the roof form which is to be cut out of the folded plate to create a turned gable is triangular. In the special case of the valley line running from the centerline of the folded plate at the ridge to the point where the gable line intersects the eave line, the in-plane shear stresses remain constant. It becomes necessary, however, to add a high strength continuous longitudinal line member to deal with the compressive and tensile forces due to in-plane bending.

2.4.2 Salt Box Roofs

Salt box construction is a term referring to the modified geometry of a single bay roof. The roof form is distinguished by the horizontal projected ridge to eave distance differing on either side of the roof. Additionally, the pitch may vary from one side of the roof to the other. This roof form is commonly found in New England, but is gaining in nation-wide popularity, primarily where the roof cavity is employed as habitable space. Light can enter the roof cavity from windows punctured in the height of the wall extending into the roof cavity space. The folded plate is well-suited for adaptation to the salt box roof geometry. The analysis is modified only in the magnitude of the in-plane load. The

total ridge line reaction from both roof panels is distributed according to the roof slopes. Let α_1 and α_2 represent the angles of the respective sides of the roof. The ratio of the in-plane load of roof side one to the in-plane of roof side two is equal to $\cos(\alpha_2)/\cos(\alpha_1)$. Hence the steeper of the roof panels carries a greater load.

2.4.3 Hipped Gable Roofs

Hipped gables refer to the sloping inward of the endwall gable from a vertical plane. The sloped, triangular hipped gable is subjected to projected live and dead loads. The hipped gable effects the folded plate behavior by depositing an edge reaction in the plane of the longitudinal roof panels. This in-plane force is resisted by the "plate" action of the roof panel in the longitudinal direction. Bending and shear stresses are developed. Simplifying assumptions with regard to the edge reaction can be made for the triangular hipped gable, however, further study into hipped gable behavior is recommended.

Chapter 3

Ridge Beam System

The ridge beam system depends on a primary framing element at the fold line to carry the ridge line loads to gable end supports. The panel elements span from the eave line to the ridge line in one-way beam action. The roof behaves as a diaphragm in resisting wind and seismic loadings. This diaphragm behavior is similar to the "plate" action of the folded plate. Longitudinal line members perform the same function of resisting flexural forces as in the folded plate. Similarly, panel to panel shear is carried out to the gable line supports. The analysis and design of the roof panels with respect to one-way "slab" and "plate" action is summarized in the following sections for convenience.

3.1 Review of One-Way Slab Action

The flexural rigidity of a sandwich is the sum of the flexural rigidity of the face and core, measured about the centroidal axes:

$$ei = \frac{E_f b t^3}{6} + \frac{E_f b t d^2}{2} + \frac{E_c b c^3}{12}$$

If the beam is wide ($b \gg c$) the lateral expansions and contractions in the longitudinal direction are restricted by the shear resistance of the face and core; it is reasonable to assume that the strains in the longitudinal direction are zero. The ratio of stress to strain in the transverse direction is therefore $E/(1-\nu^2)$ for both membrane and local bending stresses. This value replaces E in the above flexural rigidity equation [Allen, 69].

3.1.0.1 One-Way Slab Action Stresses

The stresses in the face and core may be determined by ordinary bending theory modified to account for the composite nature of the sandwich cross section. The maximum stress in the face and core are, respectively:

$$\sigma_{(f)max} = \frac{w_s H^2 E_f h}{8 ei} \frac{1}{2}$$

$$\sigma_{(c)max} = \frac{w_s H^2 E_c c}{8 ei} \frac{1}{2}$$

The shear stress in the core is given by:

$$\tau_c = \frac{w_s H}{2 ei} [E_f t d/2 + E_c c^2/8]$$

3.1.0.2 One-Way Slab Action Deflections

In general, the displacements of a statically determinant system can be found by superimposing the bending and shearing deflections. For a simply supported beam of span H , under a uniformly distributed load of w_s , the maximum bending deflection is:

$$\delta_1 = \frac{5 w_s H^4}{384 ei}$$

The maximum shear deflection is:

$$\delta_2 = \frac{w_s H^2}{8 A G_c}$$

where,

$$A = \frac{b d^2}{c} \approx b c$$

The final maximum deflection is:

$$w_{max} = \delta_1 + \delta_2$$

3.2 Review of Plate Action

The plate action of the roof diaphragm for a roof system which incorporates longitudinal line members at the eave and ridge is summarized. The in-plane loads, W_p , are a result of the roof system resisting predominately horizontal wind and seismic loads as a roof diaphragm behavior of the roof system. The determination of roof diaphragm loads is discussed in Chapter 6.

3.2.1 Plate Action Stresses

The maximum axial stress in the line member in the longitudinal direction is calculated from beam theory assuming that only the longitudinal line members contribute to the moment of inertia:

$$(\sigma_e)_{max} = \frac{w_p L^2}{8 A_e H}$$

The required cross-sectional area of the longitudinal line member, A_e , to carry these axial loads can be estimated on the basis of strength requirements, by the formula:

$$A_e = \frac{w_p L^2}{8 \sigma_{all} H}$$

The diaphragm action of the panels carry the shear loads to the gable line. The shear varies linearly from the maximum value at the gable lines to a minimum value at the midspan. The maximum shear value at the gable line due to a uniformly loaded folded plate is:

$$(Q_p)_{max} = W_p(L/2)$$

The minimum shear value at the midspan, due to a uniform load over one half of the folded plate span is:

$$(Q_p)_{min} = W_p(L/8)$$

The maximum in-plane shear stress in the faces at the gable lines can be found as:

$$(\tau_{fp})_{max} = \frac{W_p L}{2A_p}$$

where,

$$A_p = \text{Transformed transverse cross sectional area of sandwich panel.} \\ = [2(t) + (G_{cp} / G_f) c] H$$

The maximum in-plane shear stress in the core is:

$$(\tau_{cp})_{max} = \frac{G_{cp}}{G_f} [(\tau_{fp})_{max}]$$

3.2.2 Plate Action Deflections

The in-plane deflection of the "plate" is the sum of four parts: shear deflection of the "plate" (δ_s), seam slip deflections (δ_{ss}), eave line member splice deflections (δ_e), and flexural deflection (δ_f) of the "plate" acting as a deep beam girder.

The midspan shear deflection, δ_s , is:

$$\delta_s = \frac{W_p L^2}{8A_p G_f}$$

The total midspan deflection due to seam slip, δ_{ss} , can be found by summing the seam slip deflections at each joint between the support and the midspan.

The total midspan deflection due to splice deflections, δ_e , can be found by summing the deflections at each splice in the eave line member multiplied by H and divided by the distance of the splice from the gable line.

For a uniformly loaded simple span, the midspan deflection is:

$$\delta_f = \frac{5W_p L^4}{384 E_e I_p}$$

where,

$$I_p = A_e H^2/2$$

The effect of "plate" deformations on the vertical ridge deflection and lateral eave deflection can be determined geometrically. Using a Williot diagram (Figure 2-5) the vertical ridge deflection is:

$$\delta_v = \frac{\delta_s + \delta_{ss} + \delta_f}{\sin(\alpha)}$$

A simplified expression for horizontal eave deflections utilizing linear geometry, which assumes small angle rotations, is:

$$\delta_h = \delta_v(D/B)$$

3.3 Ridge Beam Design

The ridge beam carries the reactions from the upper end of the rafters, or a tributary load area equal to one-half the roof area. The load per unit length along the ridge beam, V_r , is:

$$V_r = [w_l \cos(\alpha) + w_d] H$$

The maximum moment for a simply supported ridge beam is:

$$M_r = \frac{V_r L_r^2}{8}$$

where,

L_r = Length of the ridge beam (in.).

The required section modulus for the ridge beam, S_{req} , is [A.I.T.C., 85]:

$$S_{req} = \frac{M_r}{C_f F_b}$$

where,

$$C_f = (12/d_r)^{1/9}$$

= Size factor for beams deeper than 12 inches. As the depth of the beam increases, there is a slight decrease in the bending strength.

d_r = Depth of ridge beam (in.).

F_b = Allowable flexural stress for extreme fiber in bending (p.s.i.).

The required moment of inertia determined by deflection constraints, I_{req} , is:

$$I_{req} = \frac{5 V_r L_r^3 f}{384 E_r}$$

where,

f = Allowable displacement factor (i.e. length of span/ f = Allowable displacement) (-).

E_r = Young's modulus of ridge beam material (p.s.i.).

The allowable design value for shear stress, F_v , must not be exceeded by the maximum shear stress in the rafter, f_v :

$$f_v = \frac{3 V_r L_r}{4 b_r d_r}$$

where,

b_r = Width of ridge beam (in.).

3.3.1 Ridge Beam Design Example

Two options of ridge beam construction will be examined: structural glued laminated beam, and a laminated veneer lumber beam. The beam is laterally supported along its length and is fixed to prevent side movement at the top and bottom of the beam ends.

The transverse load per unit length resulting from a live load of 40 p.s.f, a dead load of 9.6 p.s.f., an eave to eave width of 28 feet, and a pitch of 6/12 is:

$$V_r = \left[\frac{40}{144} \cos(26.57) + \frac{9.6}{144} \right] 187.8 = 59.19 (\text{lbs./in.})$$

The maximum moment is:

$$M_r = \frac{(59.19) 240^2}{8} = 426,200 (\text{lbs.*in.})$$

3.3.1.1 structural glued laminated beam

Structural glued laminated timber, S.G.L., is used as load carrying structural framing and refers to an engineered stress-rated product of a timber laminating plant. S.G.L. is comprised of assemblies of suitably selected and prepared wood laminates bonded together with adhesives. The grain of all laminates is oriented approximately parallel in the longitudinal direction. The individual laminates are typically, and do not exceed, standard dimensional two inch lumber. The properties of Southern Pine as used in structural glued laminated beams are as follows:

$$F_b = 2400 \text{ p.s.i.}$$

$$F_v = 200 \text{ p.s.i.}$$

$$E_r = 1,700,000 \text{ p.s.i.}$$

The required section modulus for the beam is [A.I.T.C., 85]:

$$S_{req} = \frac{426,200}{2400} = 177.6 (\text{in.}^3)$$

The required moment of inertia determined by deflection constraints is:

$$I_{req} = \frac{5(59.19)(240)^3}{384(1,700,000)} = 1504(\text{in.}^4)$$

A 3x19.5 inch structural glued laminated ridge beam with a section modulus, reduced by the size factor of 0.95, of 180.1 (in.³) and a moment of inertia of 1854 (in.⁴) satisfies the design requirements.

The check on the allowable design value for shear stress of 200 p.s.i. is also satisfied.

$$f_v = \frac{3(59.19)240}{4(3.0)19.5} = 182.1(\text{p.s.i.})$$

To summarize the design: a structural glued laminated beam of Southern Pine, 3.0 inches thick and 19.5 inches deep, comprised of 13 laminations.

3.3.1.2 laminated veneer lumber beam

Laminated Veneer Lumber, L.V.L., is a continuous, laminated veneer product. L.V.L. is manufactured with the grain running parallel to the beam. The random distribution of any defects such as knots, as in ordinary sawn lumber, results in much greater carrying capacity, less variability, and no warp or twist. Produced in lengths up to 80 feet, it is available in 3.5 to 48 inch depths and thicknesses from 0.75 to 3.0 inches.

The properties of L.V.L. are:

$$F_b = 2800 \text{ p.s.i.}$$

$$F_v = 250 \text{ p.s.i.}$$

$$E_r = 2,000,000 \text{ p.s.i.}$$

The required section modulus for the beam is [A.I.T.C., 85]:

$$S_{req} = \frac{426,200}{2800} = 152.2(\text{in.}^3)$$

The required moment of inertia determined by deflection constraints is:

$$I_{req} = \frac{5(59.19)(240)^3}{384(2,000,000)} = 1278.5(\text{in.}^4)$$

A 3x18 inch laminated veneer lumber ridge beam with a section modulus, reduced by the size factor of 0.96, of 154.8 (in.³) and a moment of inertia of 1458 (in.⁴) satisfies the design requirements.

The check on the allowable design value for shear stress of 250 p.s.i. is also satisfied.

$$f_v = \frac{3(59.19)240}{4(3.0)18.0} = 197.3(\text{p.s.i.})$$

A summary of the design is a laminated veneer lumber ridge beam, 3.0 inches wide and 18.0 inches deep.

3.4 Comparison of Ridge Beam to Folded Plate System

The ridge beam enables roof complexities to be constructed with greater ease than in the folded plate. The ridge beam provides a primary frame on which the panel elements can be supported. Dormers can be incorporated into the panel element in the factory before shipment to the site. Stringers along either edge of the panel element reinforce the panel in bending to compensate for areas of the panel element removed to place the dormer. In the case of turned gables and hipped gables, timbers are placed along the valleys and hips to act as lines of support for the panel elements. The introduction of this primary frame reduces the design flexibility of the building system.

In comparison to a folded plate, the ridge beam improves the redundancy for the system. The failure of any one component in the folded plate would result in the failure of the entire system, while, in the ridge beam system the failure of one panel element does

not result in the collapse of the entire roof structure. The issue of redundancy is discussed in greater depth in Section 8.2.

Chapter 4

Floor Tied System

The use of roof cavity as usable space implies the presence of a floor unit, which may be incorporated into the structural system of the roof. The floor unit can be used as a tension tie to resist the lateral thrust of the roof. The in-plane loads of the floor tied system are the same as in the case of the folded plate. Rather than resisting these in-plane loads through "plate" action, the floor tied structural system behaves as a truss. The horizontal thrust component of the in-plane loads are resisted by the floor unit acting as a tension tie between eave lines. The roof panels act as compression struts and are subjected to compressional axial loads equal to the in-plane loads. The analysis and the design of the roof panels must include both the axial compression and transverse bending of the sandwich panels.

4.1 Buckling of Sandwich Panels

In the process of buckling, an axially compressed, simple pin-ended column deflects laterally in bending. The curvature of the column due to lateral bending produces both an eccentricity of the load relative to the axis, and a shear component transverse to the column axis. In most conventional columns the shear stiffness of the column is very high relative to the bending stiffness, and the deformations due to shear are small enough to be neglected. In sandwich construction shear distortions are not insignificant and may reduce buckling capacity from loads calculated from classical Euler theory. The following equations determine the critical buckling load, P_{cr} in terms of shear and bending deformations for a pin-ended column [Structural Plastics Design Manual, 84].

$$\frac{1}{P_{cr}} = \frac{H^2}{\pi^2 EI} + \frac{1}{bdG_c}$$

The first part of the right hand equation is the critical buckling load with infinite shear stiffness and finite bending stiffness. The second part of the equation is the critical buckling load for a column of finite shear stiffness and infinite bending stiffness, and either a symmetrical or anti-symmetrical buckling mode with respect to the column mid-length.

The critical buckling load, including shear deformations can be written as:

$$P_{cr} = \frac{\pi^2 eI H^2}{1 + \pi^2 eI (H^2 b d G_c)}$$

4.2 Combined Loads

The maximum combined stress will occur at the midspan of the panel element. It is the sum of the axial stresses in the concave side of the panel. Generally the actual compression stresses must be less than the allowable compression stress and less than one third of the critical wrinkling stress. The wrinkling stress is given by:

$$\sigma_w = 0.5 (E_f E_c G_c)^{1/3}$$

Chapter 5

Thermal and Hygroscopic Stresses and Deflections in Sandwich Panels

5.1 Introduction

Face materials of sandwich panels undergo dimensional changes when subjected to moisture or temperature changes. The associated linear expansion and contraction of the faces can cause significant bowing in sandwich panels which are free to move; significant stresses in panels which are restrained. Thermal and hygroscopic stresses and deflections are an important consideration in sandwich panel applications in the building industry for the following reasons:

1. Low- or non- water-absorbing face materials typically have large coefficients of thermal expansion.
2. Water-absorbing face materials greatly expand and contract with varying moisture content. Exterior finish coats are typically water permeable; furthermore, vapor drive, with the accompanied water buildup, may occur.
3. During summer and winter seasons, extreme temperature differences between the faces may approach 100 degrees Fahrenheit.
4. In unrestrained panels, thermal deformations are often of the same order of magnitude as deformations due to external loads, and are a critical component in the stiffness design of the panel. Water leakage and air infiltration due gaps created by thermal deformations lower the panel's utilitarian properties.
5. In restrained sandwich panels, thermal stresses may exceed allowable values.
6. Special attention must be paid to the edge reactions required of the fastening system.

While the effects of temperature are used to illustrate these critical effects, the principles developed are applicable to the analysis of hygroscopic (moisture) effects, or dimensional changes resulting from other environmental exposures or time dependent effects.

5.2 Thermal Analysis of a Sandwich Beam

The thermal behavior of small width sandwich beams differ from that of isotropic sandwich panels of substantial width (slab). It is helpful, however, to introduce thermal behavior with simplified beam behavior, before entering into more complex two-way sandwich slab behavior. Moreover, beam analysis is useful for preliminary investigations as an approximation of the severity of deflections and stresses for the more complex two-way behavior of wide panels.

5.2.1 Unrestrained Sandwich Beam Behavior

When opposite faces of an unrestrained sandwich beam undergo different dimensional changes, a strain differential is imposed across the beam thickness. The unrestrained sandwich beam bows to a radius of curvature, R_c , equal to:

$$R_c = \frac{t_c}{\epsilon_2 - \epsilon_1}$$

where,

$$\begin{aligned} t_c &= \text{Distance between the centerlines of the two sandwich faces (in.).} \\ &= (t+c)/2 \approx d/2 \approx c \\ \epsilon_2, \epsilon_1 &= \text{Unit dimensional change of opposite faces (-).} \end{aligned}$$

The unit dimensional change, or strain, is typically taken from a reference condition such as completion of manufacture, when the faces are incorporated into the composite structure. If the strain is assumed constant over the beam length, H , the effect is analogous to a beam subjected to equal bending moments at either end (a constant moment applied over the length of the beam). The maximum deflection occurring at the midspan is:

$$(w)_{max} = \frac{(\epsilon_2 - \epsilon_1)H^2}{8d}$$

In the case of a uniform temperature change,

$$\varepsilon_i = \alpha_{ti} T_i$$

where,

ε_i = Strain due to thermal effects of i face (-).

α_{ti} = Coefficient of thermal expansion of the i face ((-)/°F).

T_i = Temperature change of the i face from the reference condition (°F).

5.2.2 Restrained Sandwich Beam Behavior

Continuously spanning sandwich beams may be supported by primary framing at intermediate points along the panel length. In a roof system the intermediate support may be either a purlin or a bearing wall connecting to the roof plane. When opposing faces undergo differing dimensional changes, reactions develop at the supports to prevent deflections. These restraining reactions generate bending and shear stresses. Given the typically weak strength properties of core material, shear stresses are of critical importance, but critical deformations and moments must also be checked for these indeterminate structures.

5.3 Thermal Analysis of a Two-way Sandwich Slab

Thermal two-way slab behavior differs from one-way beam behavior in that a wide unrestrained beam (a slab) warps to a two-dimensional curved surface. The unrestrained isotropic slab would conform in shape to a spherical surface with double curvature. The radius of curvature of the plate, R_c , is equal to:

$$R_c = \frac{t_c}{\varepsilon_2 - \varepsilon_1}$$

In their practical use, however, rectangular sandwich panels are held in place by edge fasteners. Significant edge reactions are developed to restrain the panel edges from bowing.

5.3.1 Two-way Sandwich Slab Assumptions

The average temperature of one face is assumed to be T degrees higher than other face. Equations describing deflections, bending and torsional moments, transverse shear, and edge reactions of a rectangular sandwich panel are listed for two differing boundary conditions: the case of two opposite edges simply supported and the other two free, and the case of four edges simply supported. Since transverse shear forces occur, shear deformation of the core must be considered. The assumptions made in the analysis are:

1. Plate is assumed to be free to expand in its plane.
2. Thickness of the faces is small in comparison to the core.
3. Deflections of the panel are small in comparison to the panel thickness.
4. Bending stiffness of the core is negligible compared to that of the face.
5. Thermal gradient in the core results in negligible normal bending stresses which are neglected.
6. Distance between faces remains constant.
7. Face and core materials are isotropic.
8. Constant temperature distribution throughout each face.
9. Equal in-plane biaxial expansion of the faces due to thermal and moisture expansion.

5.3.2 Two-way Slab with Two Opposite Edges Simply Supported and Remaining Edges Free

The case for which the edges $x=0, x=H$ are simply supported and the edges $y=\pm b/2$ are free, approximate the boundary conditions of a panel element in the mid-section of the roof system (see Figure 5-1). The simply supported edges correspond to the ridge and eave line; the two free edges correspond to the panel to panel connection. The roof system can be idealized as a series of connected panel elements extending for infinity with the free edges connected to one another in joints which are free to rotate. In reality, the panel to panel joints possess some degree of rotational stiffness, and are restrained in freedom of

vertical deflections by their eventual connection to the gable line. This approximation of the panel's boundary conditions will result in deflections slightly larger than those resulting from real-world boundary conditions.

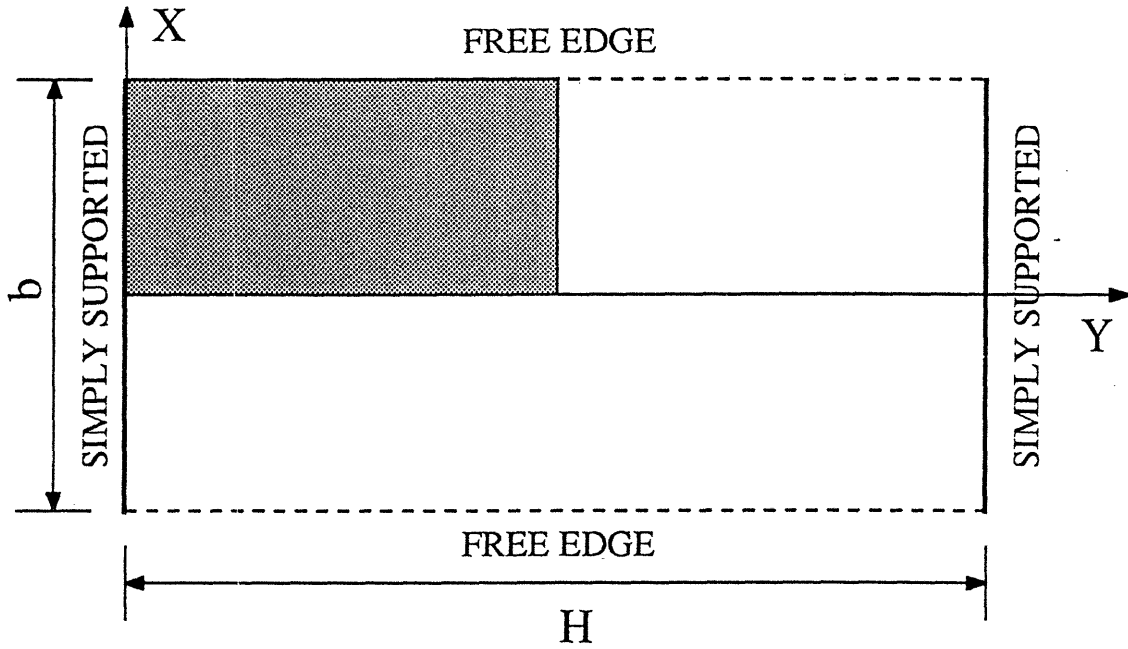

Figure 5-1: Two-way Sandwich Slab with Two Opposite Edges Simply Supported and Remaining Edges Free

The deflection is given by [Bijlaard, 69]:

$$w = -[\alpha_t T(1 + \nu_f)/t_c][x(H-x)/2] + \sum_{m=1,3,5,\dots}^{\infty} [A_m \cosh(\lambda_m y) + B_m \lambda_m y \sinh(\lambda_m y)] \sin(\lambda_m x)$$

where,

$$B_m = \frac{8 \alpha_t (1 - \nu_f^2) T}{\lambda_m^3 H t_c} \times$$

$$\frac{\sinh(\alpha_m)}{[3 + \nu_f + 2(1 - \nu_f) \lambda_m^2 e i / G_c t_c] \sinh(2 \alpha_m) - 2(1 - \nu_f) \alpha_m - [2 \lambda_m (1 - \nu_f) e i / G_c t_c] p_m \coth(\gamma_m) [\cosh(2 \alpha_m) - 1]}$$

α_t = Thermal coefficient of expansion for the face material ((-)/°F).

T = Difference between the average temperature of the two faces (°F).

$$\lambda_m = \frac{m \pi}{H}$$

$$\alpha_m = \frac{m \pi b}{2H}$$

$$p_m = \{\lambda_m^2 + [2 G_c t_c / (1 - \nu_f) ei]\}^{1/2}$$

$$\gamma_m = \frac{p_m b}{2}$$

$$E_m = [2 \lambda_m^3 ei \sinh(\alpha_m) / \sinh(\gamma_m)] B_m$$

$$A_m = \{[(1 + \nu_f) / (1 - \nu_f)] - \alpha_m \coth(\alpha_m)\} B_m$$

The shear forces are:

$$Q_x = \sum_{m=1,3,5,\dots}^{\infty} [(E_m p_m / \lambda_m) \cosh(p_m y) - 2 \lambda_m^3 ei B_m \cosh(\lambda_m y)] \cos(\lambda_m x)$$

$$Q_y = \sum_{m=1,3,5,\dots}^{\infty} [E_m \sinh(p_m y) - 2 \lambda_m^3 ei B_m \sinh(\lambda_m y)] \sin(\lambda_m x)$$

The bending and twisting moments are:

$$M_x = ei \sum_{m=1,3,5,\dots}^{\infty} (\lambda_m^2 \{[(1 - \nu_f) A_m - 2 \nu_f B_m] \cosh(\lambda_m y) + (1 - \nu_f) B_m \lambda_m \sinh(\lambda_m y)\} + [(1 - \nu_f) / G_c t_c] [E_m p_m \cosh(p_m y) - 2 \lambda_m^4 ei B_m \cosh(\lambda_m y)]) \sin(\lambda_m x)$$

$$M_y = [\alpha_t T ei (1 + \nu_f^2) / t_c] - ei \sum_{m=1,3,5,\dots}^{\infty} (\lambda_m^2 \{[(1 - \nu_f) A_m + B_m] \cosh(\lambda_m y) + (1 - \nu_f) B_m \lambda_m y \sinh(\lambda_m y)\} - [(1 - \nu_f) / G_c t_c] [E_m p_m \cosh(p_m y) - 2 \lambda_m^4 ei B_m \cosh(\lambda_m y)]) \sin(\lambda_m x)$$

$$M_{xy} = (1 - \nu_f) ei \sum_{m=1,3,5,\dots}^{\infty} \{\lambda_m^2 [(A_m + B_m) \sinh(\lambda_m y) + B_m \lambda_m y \cosh(\lambda_m y)] - (1/2 \lambda_m G_c t_c) [E_m (p_m^2 + \lambda_m^2) \sinh(p_m y) - 4 \lambda_m^5 ei B_m \sinh(\lambda_m y)]\} \cos(\lambda_m x)$$

The tensile forces transmitted through the attaching bolts are:

$$-(V_y)_{x=0} = ei \sum_{m=1,3,5,\dots}^{\infty} B_m \lambda_m^3 \{ [5 - v_f - (1 - v_f) \alpha_m \coth(\alpha_m) + [2 (1 - v_f) ei \lambda_m^2 / G_c t_c]] \times \\ \cosh(\lambda_m y) + (1 - v_f) \lambda_m y \sinh(\lambda_m y) - \\ [2 p_m \sinh(\alpha_m) / \lambda_m \sinh(\gamma_m)] \{ [(1 - v_f) ei \lambda_m^2 / G_c t_c] + 2 \} \cosh(p_m y) \}$$

5.3.3 Two-way Sandwich Slab with Four Edges Simply Supported

The case for which the edges $x=0$, $x=H$, $y=\pm b/2$ are simply supported, approximates the boundary conditions of a panel element attaching to the gable line at the end-section of the roof system (see Figure 5-2). The three opposite, simply supported edges correspond to the ridge, eave and gable line for a panel element at the end-section of the roof system. The boundary condition along the edge connecting to the adjacent panel is in actuality neither free nor simply supported. If this edge is assumed simply supported a more severe state of stresses is imposed. This approximation of the panel boundary conditions results in stresses slightly greater than those found with real-world boundary conditions.

The deflection is given by [Bijlaard, 69]:

$$w = -4 \alpha_t T (1 + v_f) H^2 / \pi^3 t_c \sum_{m=1,3,5,\dots}^{\infty} \sin(\lambda_m x) / m^3 [1 - \cosh(\lambda_m y) / \cosh(\alpha_m)]$$

The bending and twisting moments are:

$$M_x = 4 \alpha_t T (1 - v_f^2) ei / \pi t_c \sum_{m=1,3,5,\dots}^{\infty} \sin(\lambda_m x) \cosh(\lambda_m y) / \cosh(\alpha_m) m$$

$$M_y = \alpha_t T (1 - v_f^2) ei / t_c - 4 \alpha_t T (1 - v_f^2) ei / \pi t_c \sum_{m=1,3,5,\dots}^{\infty} \sin(\lambda_m x) \cosh(\lambda_m y) / \cosh(\alpha_m) m$$

$$M_{xy} = 4 \alpha_t T (1 - v_f^2) ei / \pi t_c \sum_{m=1,3,5,\dots}^{\infty} \cos(\lambda_m x) \sinh(\lambda_m y) / \cosh(\alpha_m) m$$

The twisting moment, M_{xy} becomes infinite at the corners. The corner reactions, R , are infinite and are directed upwards.

$$(R)_{x=0, y=b/2} = 2 (M_{xy})_{x=0, y=b/2}$$

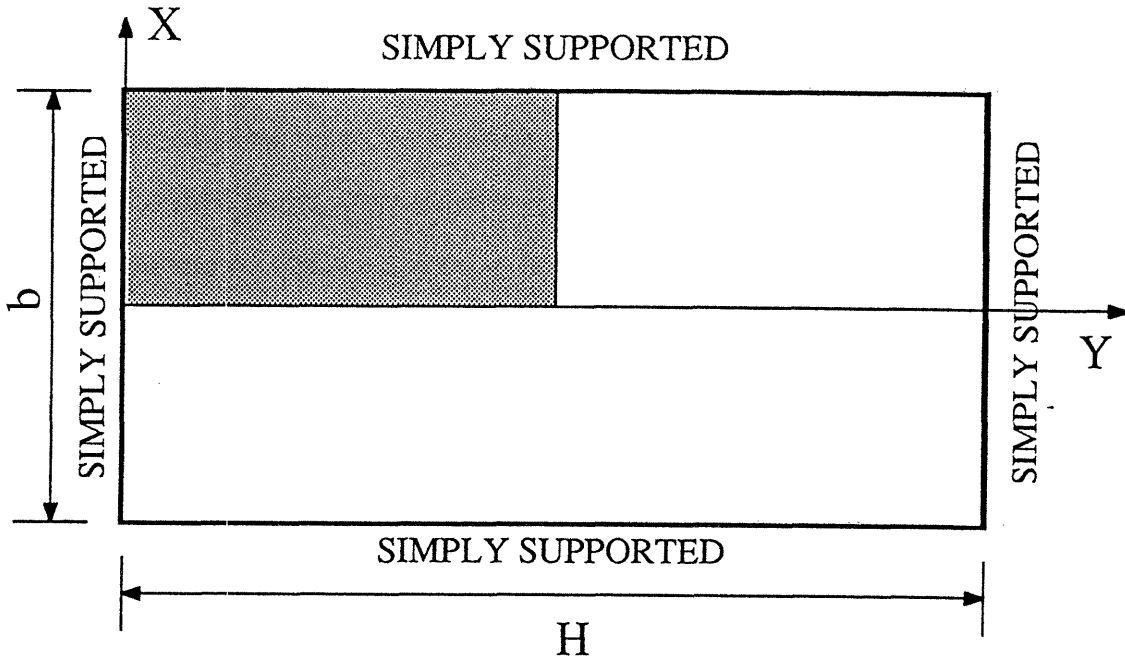

Figure 5-2: Panel with Four Edges Simply Supported

The statically equivalent reactions continuously distributed along the edge are:

$$V_x = -4 \alpha_i T (1 - \nu_f^2) e_i / H t_c \sum_{m=1,3,5,\dots}^{\infty} \cosh(\lambda_m y) / \cosh(\alpha_m)$$

5.4 Precision

The precision of the numerical solution depends on the summation limits. Computers are limited in the range of summation by limitations on number size. The hyperbolic functions rapidly approach large values over a small domain. Therefore to achieve greater precision, terms which approach a limit as summation limits become large, are replaced by their final values so as to prevent floating number errors.

5.5 Infinite Corner Reactions

Variations in the twisting moment create a singularity at the corner. As the summation limits approach infinity, the corner reactions approach infinity. In calculating the edge reactions for fasteners, this inconsistency in the solution of a mathematical model can be remedied by applying the laws of equilibrium and symmetry. The outer fastener reaction nearest the corner is set equal to the negative value of the edge reaction obtained from integrating from the midpoint of the outer fastener and the adjacent fastener to the midpoint of the panel length. Reactions of fasteners inside of the outer corner fastener are found by integrating the edge reactions over the respective tributary areas of the fastener.

5.6 Effect of Panel Width

There is a transition in thermal behavior from a sandwich beam to a two-way sandwich slab as panel width increases. For a sandwich slab (exposed to a gradient) with opposite edges simply supported, the uniform bending stresses along the simply supported edge do not vary with the panel width. This fact follows from the uniform curvature induced on the panel edge from the thermal or hygroscopic gradient. The reactions required to induce this uniform moment are dependant on panel width. For a sandwich slab with opposite edges simply supported, the panel reactions can be measured as a function of the midspan reactions of the simply supported edge. The idea behind measuring the reaction at the midpoint is that this parameter for monitoring panel width effects on edge reactions is not sensitive to the summation limits. The equations show that fastener reactions increase as the panel width is decreased. This is contrary to common engineering sense and is due to the infinite corner reactions. The equations become ill-conditioned due to the division of very large numbers by less large numbers. This mathematical error in the approximate equations result in erroneous output. In reality, a sandwich beam is not restrained from from bowing along its supported edge.

5.7 Computer Programs

Included in the appendix are two programs to study the thermal and hygroscopic behavior of rectangular sandwich slabs. *S.f* is a fortran program which calculates the deflections, shear stresses, bending stresses, twisting stresses for a rectangular isotropic sandwich panel with: two edges simply supported, the other two edges free; four edges simply supported. Program *B.f* is a fortran program which calculates the reaction along the panel edges for a rectangular isotropic sandwich panel with: two edges simply supported, the other two edges free; four edges simply supported. Oriented strand board, and a polyurethane foam core are the materials input into the programs: face thickness is one inch, the core thickness is twelve inches. The thermal coefficient of expansion used for O.S.B. is parallel to the transverse direction of the panel. The thermal gradient is 100°F. The programs are run for two panel geometries: 96 and 48 inch panel width; 240 inch panel length. The effect of varying the summation limits for each case is studied.

5.8 Effect of Core Depth

Core depth is a controlling parameter in the thermal behavior of sandwich structures. From examination of the thermal deflection equation for an unrestrained sandwich beam of given length and strain, deflections are inversely proportional to the core depth (more precisely, the distance between the centerlines of the two sandwich faces).

$$(w)_{max} = \frac{(\epsilon_2 - \epsilon_1) H^2}{8 d} \propto \frac{1}{d}$$

Assuming that the face materials are linear elastic, the same relationship applies to forces resulting from restrained sandwich beam behavior.

Dimensionally sensitive face materials require larger core thicknesses if exposed to

thermal and hygroscopic gradients. For example, at a core depth of 9.54 inches, an aluminum faced sandwich beam exposed to a 100°F temperature gradient and spanning twenty-feet thermally bows to the deflection criteria of $L/240$. At a core depth of twelve inches 80% of the allowable deflections are due to thermal bowing. Therefore, if the panel design is controlled by stiffness, the load capacity of the panel is reduced to 20% of the load capacity of a panel not exposed to a thermal gradient. Selection of dimensionally sensitive face materials for use in composite action with structural insulating cores should be avoided. Furthermore, inexpensive core materials possessing less effective insulating qualities are well suited for deep cores.

5.9 Changes in Length

A strain gradient imposed across the sandwich panel results in a change in the overall panel length, measured at the mid-depth of the panel core, of:

$$\Delta H = \frac{(\epsilon_2 - \epsilon_1)H}{2}$$

Panel joints must allow for this differential movement along their length. Joint sealants, connections and roof membranes must be designed to accommodate such movements, which can become significant for long panels. A twenty five foot long, steel faced panel subjected to a 100 °F thermal gradient results in a change of overall length of 0.0975 inches.

Expansion joints should be provided along the roof panel length, otherwise, significant movements in the longitudinal direction will occur. Panel joints must allow for expansion and contraction between panel to panel joints. Joint sealants, connections and roof membranes must be designed to accommodate such movements. If expansion joints are not periodically provided at panel to panel connections, the change in roof span can be significant. A steel faced panel with a roof span of fifty feet, subjected to a 100 °F

thermal gradient results in a change of overall length of 0.195 inches at the panel mid-depth. The thermally exposed exterior face, expands in longitudinal length by 0.39 inches.

Chapter 6

Code Design

There are three major code bodies in the United States: Uniform Building Code (UBC), Council of American Building Officials (CABO), and the Building Officials and Code Administrators (BOCA). The Uniform Building Code is the most exhaustive and extensive of the three codes and will be used as the design code.

6.1 Uniform Building Code 88

UBC specifies:

1. Calculation of design loads
2. Stresses < allowable
3. Deflection constraints
4. Joint design

Every building component should be provided with strength adequate to resist the most critical effect resulting from the following combination of loads:

1. Dead plus roof live (or snow).¹
2. Dead plus wind¹ (or seismic).
3. Dead plus wind plus snow/2.¹
4. Dead plus snow plus wind/2.¹
5. Dead plus snow² plus seismic.

¹Crane hook loads need not be combined with roof live load nor with more than three fourth of the snow load or one-half wind load.

²Snow loads over 30 psf may be reduced 75 percent upon approval of the building official, and snow loads 30 psf or less need not be combined with seismic.

All allowable stress values specified for working stress design may be increased one-third when considering wind or earthquake forces either acting alone or when combined with vertical loads. No increase is allowed for vertical loads acting alone.

For live loads, deflections are limited to be less than the length of span divided by 240; for live and dead loads, deflections must be less than the length of span divided by 180.

Every device designed to connect prefabricated assemblies should be capable of developing the strength of the members connected, except in the case of members forming part of a structural frame designed as specified in Chapter 23 [U.B.C., 88]. Roof panel elements qualify as part of a structural frame. Connections between roofs and supporting walls should be capable of withstanding uplift and shear forces of seismic and wind origin.

6.2 Uniform Building Code 88 Design Loads

6.2.1 Roof Snow Loads

Snow loads full or unbalanced are considered in place of minimum roof live loads set forth in Table No. 23-C , because such loadings result in larger members or connections. Additionally, the potential accumulation of snow at valleys, parapets, roof structures and offsets in roofs of uneven configuration needs to be considered. Where snow loads occur, they shall be determined by the building official. Snow loads in excess of 20 pounds per square foot may be reduced for each degree of pitch over 20 degrees by R_s as determined by the following formula:

$$R_s = S/40 - 1/2$$

where,

R_s = Snow load reduction in pounds per square foot per

degree of pitch over 20 degrees.

S = Total snow load in pounds per square foot.

A roof snow load of 40 p.s.f. is assumed for prototype design. This snow load exceeds the requirements of approximately 85% of the geographical land area of the contiguous United States. Face and core thicknesses of the panel are designed for local live roof loads, in the region of the manufacture of the panel elements. A single pair of face and core thicknesses could be used with each standard length of the panel which would be tailored to the local requirements. Panels manufactured in standard lengths, and designed to resist this an average live snow load, can be utilized in areas of greater snow fall by shortening the length of span (fall-off would be added waste and cost); in areas of lesser live roof load, the sandwich panels would be over designed.

6.2.1.1 Alternate Roof Snow Load Design Procedure

An alternate roof snow design procedure is given in the UBC 88 Code. Ground snow load, P_g to be used in the determination of design snow loads for buildings is shown in Figures Nos. A-5-A, A-5-B, A-5-C [U.B.C., 88]. For areas in Figure No. A-5-A, the basic ground snow shall be determined by a building official, which is the majority of the geographical land area of the United States. This undetermined parameter creates difficulties in utilizing this method for a generalized investigation, but is listed below to show that the alternate method is not in conflict with the simplified snow load analysis.

The value of roof (or other member) snow load, P_f , is determined by the following formula:

$$P_f = C_{exp} I P_g$$

From inspection of the Figures No. A-5-A through A-5-C, a basic ground snow of 30 p.s.f. is chosen. This snow load corresponds most closely to the land area covered by a 40 p.s.f. snow load in the simplified analysis (refer to Section 6.2.1). For structures located in

densely forested or sheltered areas the snow exposure coefficient, C_{exp} , is equal to 0.9 (Table No. A-23-S [U.B.C., 88]) and represents the worst exposure. The value for occupancy importance factor, I , is equal to 1.0 (Table No. A-23-T [U.B.C., 88]) since residential structures are non-essential facilities.

The roof load is assumed to act vertically upon the area projected upon a horizontal plane.

Roof loads between 20 and 70 pounds per square foot are multiplied by C_s given in the formula:

$$C_s = 1 - (\alpha - 45) / 25 \text{ for all surfaces}$$

This C_s factor results in an increase in the roof snow load, unlike the snow load reduction factor of the simplified snow load analysis. In addition to the balanced load condition, the unbalanced loading is considered for gable roofs. Single-gable roofs with slopes greater than 3:12 are designed to sustain a uniformly distributed load equal to $1.25 P_f$ applied to one slope only. Eave overhanging roof structures are designed to sustain a uniformly distributed load of $2.0 P_f$ to account for ice dams and snow accumulation.

It is recommended that the alternate method be used for specific building design. The Alternate Roof Snow Load Design Procedure provides important information with regard to roof obstructions and snow drifting. Exposure and importance factors are accounted for in the determination of the roof snow load. The roof snow load is related directly to the ground snow, allowing more accurate load assessment by the building official from weather records. The analysis accounts for the frictional quality of the roof surface. Nonetheless, the load design criteria for a single bay roof with no eave overhang differs from the simplified roof snow analysis only in the magnitude of uniform distributed load. A snow load of 40 p.s.f. was chosen for this case study, whereas, the assumptions described in this alternative roof snow load procedure, for the worst case assumptions, result in a snow load of 67.5 p.s.f..

6.2.2 Roof Wind Loads

The minimum basic wind speed for determining design wind pressure is taken from Figure No.1 [U.B.C., 88]. A minimum basic wind speed of 100 m.p.h. includes roughly 95% of the geographic United States. An exposure factor is assigned at each site for which a building is to be designed. Exposure C has terrain which is flat and generally open, extending one-half mile or more from the site in any full quadrant and represents the most severe exposure. The design wind pressure for structures or elements of structures shall be determined for any height in accordance with the following formula:

$$p_w = C_e C_q q_s I$$

where,

p_w = Design wind pressure (p.s.i.).

C_e = Combined height, exposure and gust factor coefficient as given in Table No. 23-G [U.B.C., 88] (-).

C_q = Pressure coefficient for the structure or portion of structure under consideration as given in Table No. 23-H [U.B.C., 88] (-).

q_s = Wind stagnation pressure at the standard height of 30 feet as set forth in Table No. 23-F [U.B.C., 88] (-).

I = Importance factor as set forth in Section 2311 (i) [U.B.C., 88] (-).

For any primary frame or load resisting system the Normal Force Method may be used. In the Normal Force Method, the wind pressures act normal to all exterior surfaces simultaneously. For pressures on roofs, C_e is evaluated at the mean roof height. The design wind pressure for each element or component of a structure is determined from the wind pressure formula and C_q values from Table No. 23-H [U.B.C., 88], and is applied perpendicular to the surface. For outward acting forces the value of C_e is obtained from Table No. 23-G [U.B.C., 88] based on the mean roof height and applied over the entire height of the structure. Each element is designed for the more severe of the following loadings:

1. The pressures determined using C_q values for elements and components acting over the entire tributary area of the element.
2. The pressures determined using C_e values for local areas at discontinuities such as corners, ridges and eaves. The local pressures shall be applied over a distance from a discontinuity of 10 feet or 0.1 times the least width of the structure, whichever is less. In residential homes, 0.1 times the least width of the structure controls, and is the value used.

Table 6-1: Pressure Coefficient

Structure, description	C_q
Primary frame and systems	
Normal Force Method	
Walls:	
Windward	0.8 inward
Leeward	0.5 outward
Roofs:	
Wind perpendicular to ridge	
Leeward roof or flat roof	0.7 outward
Windward roof	
less than 2:12	0.7 outward
Slope 2:12 to less than 9:12	0.9 outward or 0.3 inward
Slope 9:12 to 12:12	0.4 inward
Slope > 12:12	0.7 inward
Wind parallel to ridge and flat roofs	0.7 outward
 Elements and components	
Roof elements	
Enclosed structures	
Slope < 9:12	1.1 outward
Slope 9:12 to 12:12	1.1 outward or 0.8 inward
Slope > 12:12	1.1 outward or inward
 Local areas at discontinuities	
Canopies or overhangs at eaves or rakes	2.8 upward
Roof ridges at ends of buildings or eaves and roof edges at the building corners	3.0 upward

The wind pressure from the Normal Force Method and elements and components need not be combined.

The wind stagnation pressure at a standard height of 30 feet is given as 26 p.s.f. in Table No. 23-F [U.B.C., 88]. Assuming a height of 20-40 feet above average level of adjoining ground, C_e is equal to 1.3. An importance factor of 1.0 is used, since residential buildings are not essential facilities.

The design of individual sandwich panels as elements and components is controlled by either local pressure areas at discontinuities, or outward or inward wind pressures applied over the tributary areas; the joints resist the uplift of these wind loads. The panels also function as a primary load resisting frame in their behavior as folded plates or roof diaphragms: the panel-panel joints carry shear forces to the gable line; longitudinal line members resist bending moments.

6.2.3 Roof Earthquake Loads

A diaphragm is defined as a horizontal or nearly horizontal system acting to transmit lateral forces to a vertical resisting element. Roof diaphragms are designed to resist forces determined by the following formula:

$$F_{px} = \frac{\sum_{l=x}^n F_l w_{px}}{\sum_{l=x}^n w_l}$$

where, w_{px} is the weight of the diaphragm and the tributary elements connected to it at level x . Where the snow load is greater than 30 p.s.f., the snow load shall be included. When configuration and load duration warrant, the load may be reduced up to 75%, when approved by a building official. To represent design limits, w_{px} includes a snow load of 30 p.s.f. and a dead load of 10 p.s.f.. The force F_{px} need not exceed $0.75 Z I w_{px}$, but shall not be less than $0.35 Z I w_{px}$. Each site is assigned to a seismic zone in accordance to Figure No. 2 [U.B.C., 88] and is assigned a zone factor, Z , in accordance with Table No. 23-I

[U.B.C., 88]. A seismic zone of 4, with a corresponding zone factor, $Z = 0.4$ has been selected to represent the most severe design criteria. From Table No. 23-K [U.B.C., 88], a residential structure is a Standard Occupancy Structure, category IV; occupancy requirements of Table No. 23-L [U.B.C., 88] assigns an importance factor, I , of 1.0. The design seismic forces are assumed to act nonconcurrently in the direction of the principal axis. Choosing the worse case of $0.75 ZI w_{px}$, a Zone 4 site, F_{px} is equal to 0.3 times w_{px} .

At each level designated x , the force F_x is applied over the area in accordance with the mass distribution of that level. To account for uncertainties in locations of loads, the mass at each level is assumed to be displaced from the calculated center of mass in each horizontal direction a distance equal to 5 percent of the building dimension at that level perpendicular to the direction of force considered. Connection of diaphragms to the vertical elements and to collectors and connections of collectors to the vertical elements in structures in Seismic Zones 3 and 4, having a plan irregularity of Type A, B, C, or D in Table No. 23-N, shall be designed without considering the one third increase usually permitted in allowable stresses for elements resisting earthquake forces. Type A irregularities are where diaphragms are not flexible and torsional irregularity is to be considered. Torsional rigidity exists when the maximum story drift at one end of the structure is more than 1.2 times the average story drift of the two ends of the structure. Structural plan irregularities type B correspond to projections of the structure beyond a reentrant corner of length greater than 15 percent of the plan dimension of the structure in the given direction. Irregularity type C are diaphragms with cutouts or open areas greater than 50 percent of the gross area of the diaphragm, or changes in the effective diaphragm stiffness of more than 50 percent from one story to the next. Type D irregularities are discontinuities in the lateral force path due to out-of-plane offsets of vertical elements. A typical home in the North American market place is likely to have at least one of the above irregularities in structural plan.

6.3 Joint Loads

Included in the appendix are two fortran programs which analyze joint loads according to UBC '88. In both programs the live, dead, wind and seismic loads and their respective parameters are interactively input, and the resulting load tables for varying pitch, gable to gable length, and eave to eave width are calculated. Program *sep.f* generates load tables for the individual effect of dead, live, seismic, and wind loads on the eave, gable and ridge line. Program *comb.f* combines the separated load effects according to UBC '88 specifications. When wind and seismic forces are combined with other forces, the loads are multiplied by 0.75 to reflect the one third increase in allowable stresses (except in the case of plan irregularities of type A,B,C, or D, U.B.C. 1988 Table No. 23-N). Roof diaphragm and folded plate behavior is compiled in a table form, where geometric multipliers determine the final loads. The joint load output for the worse case load assumptions described in this chapter are included and will be referred to throughout the second half of the thesis as the standard load case. These loads represent an upper limit for which the roof system must be designed.

6.4 Proposed Code Revisions

The present body of codes are found to be lacking with respect to thermal and hygroscopic behavior. Foamed cores can provide a very high degree of thermal insulation. The solar gain on the outside face exposed to the sun cannot be readily dissipated, and large thermal gradients can be developed between the exterior and interior faces. During winter, similar thermal gradients can be developed when the exterior face is exposed to cold air and the interior face is at ambient room temperature. The British practice regarding the temperatures for which sandwich panels should be designed is found in a PSA publication, "*Technical Guidance in Sheet Cladding*" [Davies, 87]. Clause 2.4.11

states: " for composite sheet cladding in steel and aluminum external surface temperature varies with surface color and orientation. Cladding should be able to resist the following:

black and dark colors	80°C
medium colors	65°C
white or bright colors	50°C
minimum external surface temperature	-20°C

Sandwich panels should generally be designed for the most unfavorable combination of dead, live, wind, and seismic bearing in mind the effects of creep. The critical load cases are generally.

1. Dead and live load (snow) with consideration of creep and an appropriate winter thermal gradient.³
2. Dead load, wind suction, and maximum summertime thermal gradient.
3. Dead load, inward wind pressure, and maximum summertime thermal gradient.

³Due to the insulating value of the overlaying snow load, it seems reasonable to assume a temperature for the exterior face which is greater than the minimum temperature.

Current codes do not suggest any temperature gradient be used in combination with other loadings. The Uniform Building Code makes no mention of thermal gradients in its Plywood Sandwich Panel Design Section [U.B.C. Standards, 88].

6.5 Factor of Safety

A large factor of safety in the joint design is desirable. The building system strength is only as good as the joints. Lack of quality control and inspections in the field, variability in material properties, tolerance conflicts, fatigue, corrosion, long term

environmental exposures, and other unaccounted effects could result in premature failure of the joining system. For the above reasons, a factor of safety of 3.0 is proposed for mechanical joining systems. Since adhesive joints are more critically effected by the above factors, a safety factor of 7.0 is chosen. The above safety factors are generic to connections of this type.

Further exploration into the structural reliability of the roofing system is required. Variability of resistance offered by the joining system (fatigue, corrosion, tolerance conflicts, probability of future cutouts made in the roof diaphragm, dimensional and material property variations) must be established. Variability in the load: dead load variations (new roofing applied over existing roof membrane, loads attached to the ceiling undersurface), live load variations (snow drifting, wind), and load uncertainties (thermal and hygroscopic gradients, settlements, statically indeterminacy, assumed stiffness, assumptions about behavior). Acceptable limitations as to the consequences of failure must be established: cost of repair or replacement (insurance value of structure), loss of life (aversion function), importance of connection (redundancy provided), and the type of failure (warning or abrupt).

6.6 Design Method

The allowable stress method is the predominate design method for wood, steel and sandwich panel design in the present codes. The computer programs developed for panel and joint load analysis are based on the allowable stress method. Although the allowable stress method is completely satisfactory for purposes of meeting code requirements, the load factor reduction method may represent a more accurate and representational design method with respect to loads determination.

The load factor reduction method applies safety factors to the material and load The load factor reduction method is more systemized and rational in its approach to calculating loads than the allowable stress method.

The load factor reduction method increases loads and stresses to account for potential overloads, and other unknowns related to the loads and analysis. A load factor of 1.7 is assigned to wind loads. This safety factor accounts for inaccuracies in pressure distributions, uncertainties in wind gust magnitude, and other inaccuracies in analysis. Most building codes allow for a reduction in the wind load factor when combined with other loads. A lower load factor of 1.4 may be assigned to temperature effects. This lower factor of safety reflects the probability that the occurrence of significantly lower temperatures is improbable. Some building codes allow a reduction in temperature stress when combined with other loads.

Capacity reduction factors (CRF) account for mode and consequences of failure under imposed loads, low strength materials under maximum stress, and other factors. For instance, a CRF of 0.6 may be assigned to a organic/inorganic face materials, since this material may be manufactured with good material property reproducibility under adequate quality control. A CRF of 0.4 may be assigned to the shear strength of a polymer foam, recognizing that the continuous in-place foaming results in varying cell orientation, and density which may produce significant variations from assumed ultimate strength. A CRF of 0.6 may be assigned to face wrinkling strength recognizing that modulus varies less than strength, and the chance of core and foam having their lowest modulus is very remote [Structural Plastics Design Manual, 84].

PART II

Sandwich Panel Residential Roof System

Introduction

At the time of this thesis writing, the project team had not selected the final face or core material. Therefore the roof system has been developed independent of specific face and core materials. Research and development of core materials has been focused primarily on structural, insulating foams. Due to this directional push by the research group, a roof system of this panel type will be dealt with exclusively. The primary design consideration inherent in a panel type with a structural insulating core is the thermal stresses. To provide the greatest amount of flexibility, the joining system is designed to be adaptable to the three structural systems (refer to Figure 1-2):

1. Sandwich panel folded plate.
2. Sandwich panels supported by a ridge beam.
3. Sandwich panels tied by a floor system.

Chapter 7

Joint Design

7.1 Introduction

Sandwich panels must be joined to create useful structures. The joining process is a determining factor in the practicality, economy, efficiency and suitability of such components as a building system. Joint design should ideally avoid: premature failures, thermal bridges, tolerance conflicts, fatigue, excessive weight and costs, aesthetic interference, and allow for: ease of fabrication, constructibility, weather sealing, inspection, quality control, and maintenance.

In sandwich panel roof structures there are four primary joint conditions (refer to Figure 7-1):

1. Ridge line
2. Eave line
3. Gable line
4. Panel to Panel connection

7.2 Tolerances

Tolerances have a major impact on joint design, and construction assembly sequencing. The overriding premise is that the roof panel elements are precisely dimensioned and joined in the field. The panels are assumed to be fabricated to within a tolerance of one hundredth of an inch. Tolerances are examined to understand how this precise roof system will be assembled precisely on top of and joined to a less precisely constructed supporting structure. Allowable tolerance criteria must be established for the

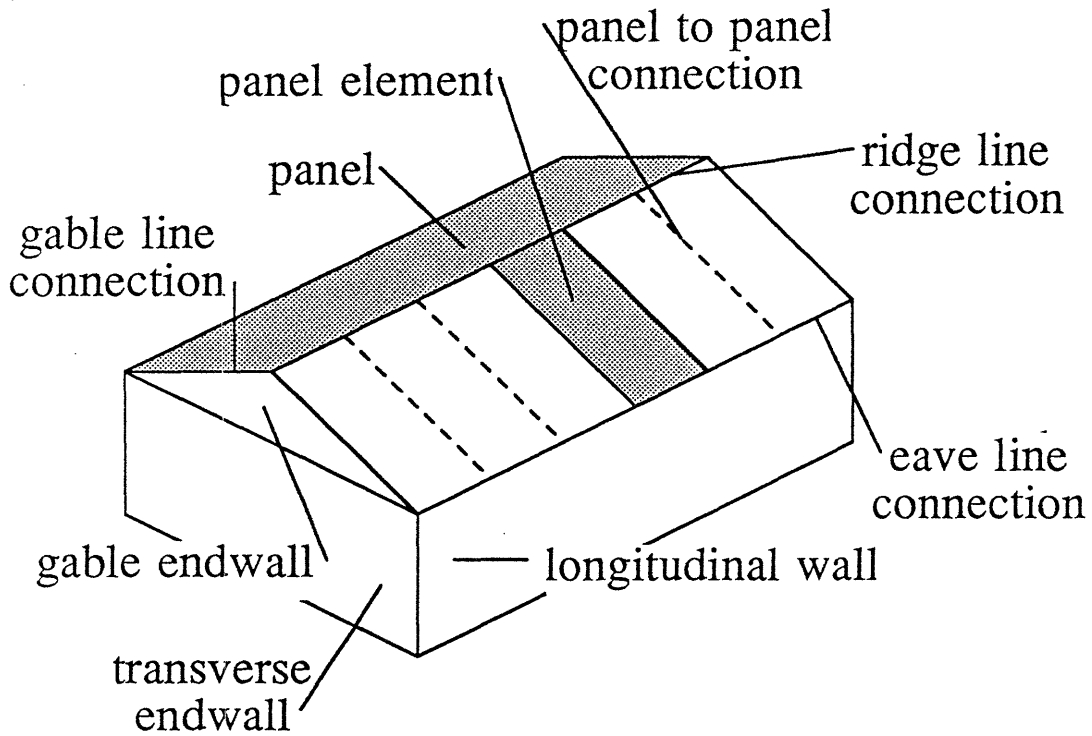

Figure 7-1: Joint Conditions

building system. Stick built construction offers an existing model to characterize the outer bounds of tolerance limits. The roof system is designed so as to be compatible with Western platform wood frame construction utilizing rafter or truss components, since this construction method represents the overwhelming majority of U.S. residential construction. A panelized roof system, installed over a wood frame structure, serves as a means of introducing a new technology to the construction industry. This roof system can be viewed as an evolutionary step (rather than a quantum jump) toward widespread acceptance of a completely panelized building system in the residential construction industry.

7.2.1 Tolerance Limitations

All dimensional tolerances can be referenced to a straight line segment of a determined length drawn through the peaks of the opposite gable ends. This reference ridge line is line segment AB of Figure 7-2-a. The length of this reference ridge line is equal to the length of the assembled roof panel span.

Sighting longitudinally along this reference ridge line, the gable lines of the opposite gable ends are not perfectly aligned, but rotated by a small angle due to elevation differences of the four corners as shown in Figure 7-2-b. Sandwich panel elements offer little torsional resistance and conform easily to this slightly twisted plane of the overall roof panel shape. If a roof span of 30 feet, a core depth of 11 inches, a face of one inch oriented strand board, a panel element length of 15 feet, and a half inch out-of-plane warping of one corner is conservatively assumed, a torque force of 438 lbs. is required at the roof panel corners; a shear stress of 18.3 p.s.i. is developed in the face. Tolerance limitations on this twisting of the roof panel need be established for aesthetic reasons only, and are typically not visually perceptible given the ratio of the angle of twist to the length of span.

The gable line tolerances (ACF and BDE) can be measured as the variation in the horizontal perpendicular distance from a line drawn normal to and through the endpoints of the reference ridge line segment AB and lying in the plane of the roof panel. Due to differences in height between gable peaks, a line drawn perpendicular to the reference ridge line in the horizontal plane differs from the horizontal projection of a line drawn perpendicular to the reference ridge line in the plane of the roof panel as shown in Figure 7-2-c. One-half inch may represent a maximum difference in gable peak heights. The resulting horizontally projected error at the corners between a line drawn horizontally and a line drawn in the plane of the roof panel is equal to the difference in gable peak heights multiplied by the eave to gable endwall height and divided by the length of span. This

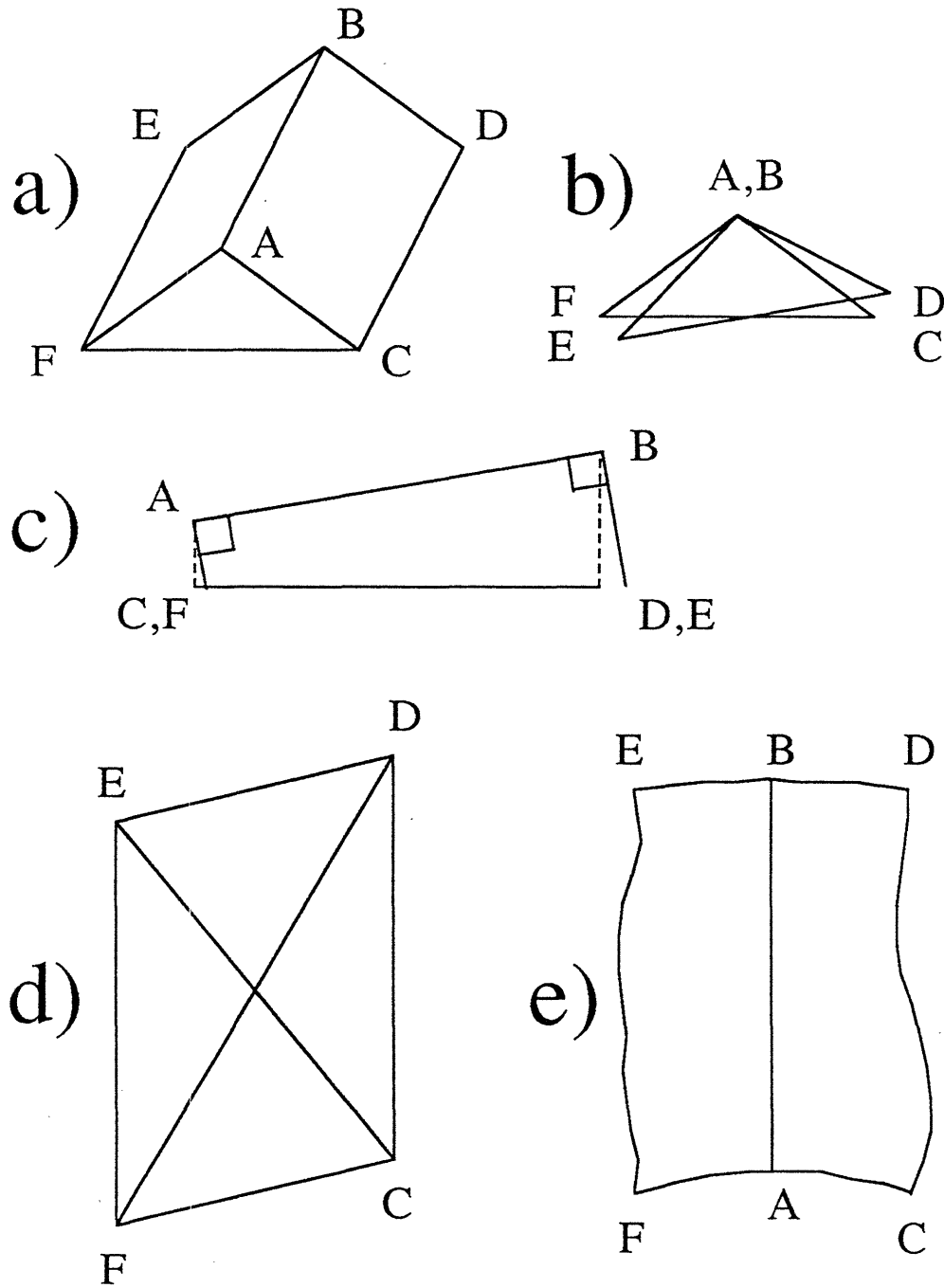

Figure 7-2: Roof Tolerances

error can become significant for short roof spans of great width or steep pitch. For

instance, a span of 20 feet, an eave to eave width of 36 feet, and a pitch of 12/12, results in an error of approximately 5/8". If gable peak elevations differ, a practical solution is to tilt the gable endwalls out of the vertical plane to permit alignment of the roof panel with the corners. Discrepancies between gable peak distances and the assembled panel roof span can usually be corrected by applying a small lateral force (pushing or a sledge-hammer).

Common construction practice limits the error in corner layout, the difference between line segment DF and CE of Figure 7-2-d, to less than one-half inch difference between diagonals from opposite corners. The maximum error in corner layout, $corner_{error}$, in the longitudinal direction due to this error in diagonal lengths, $diagonal_{error}$, and assuming that opposite transverse endwalls and longitudinal walls are of equal length, is:

$$corner_{error} = \frac{L^2 - (2B)^2 + [(L^2 + (2B)^2)^{1/2} + diagonal_{error}]^2}{2L} - L$$

For low aspect ratios the $corner_{error}$ can be significant. If the eave to eave width is 36 feet, the span length is 20 feet, and the $diagonal_{error}$ is equal to 1/2", the $corner_{error}$ is approximately one inch.

The plan of the top edge of the longitudinal walls and the gable endwalls deviate from rectilinear geometry due to errors in wall layout and wall curvature, arising from dimensionally unstable materials and poor workmanship (Figure 7-2-e). Both of these deviations in the plan result in a misalignment of the roof panel edges from precise fastener attachment points. The magnitude of this error can be corrected to less than $\pm 1/4"$ by laterally aligning and bracing the top plate after the wall have been erected.

The longitudinal wall errors are measured as the variation in the perpendicular distance measured from the reference ridge line to the fastener location on the longitudinal wall minus the length from ridge line to eave fastener location on the fabricated panel element. With the reference ridge line running from gable peak to gable peak, and the

assumption that the gable peaks are located at the midpoint of the gable endwall and opposite transverse endwalls are of equal length, the corners are equidistant from the reference ridge line. Walls in the vicinity of the corner points are relatively fixed in their location, whereas, mid-sections of gable endwalls and longitudinal walls, if not laterally braced by interior wall partitions, are generally flexible to re-positioning. The variation in the lateral position of the transverse endwalls and longitudinal wall is referred to as yaw. From discussions with numerous builders, the yaw tolerances have been set at plus or minus a quarter inch.

Roll refers to the variation in the vertical projected distance from the reference ridge line to the top edge of the longitudinal wall. Commonly, this roll is limited to $\pm 1/4"$. Unlike the lateral horizontal tolerances in the longitudinal wall where corrections are resisted by lateral bracing, the variation in height (roll) along the longitudinal wall can be corrected by shimming. After shimming to adjust wall height, the longitudinal wall is a controlled vertical projected distance and unknown horizontal projected distance from the reference ridge line. The eave line connection should localize this vertical height adjustment, and allow for lateral horizontal error.

7.2.1.1 Summary of Tolerance Limitations

A summary of tolerance limitations for stick built construction is as follows:

Difference in gable peak elevations = $1/2"$

Difference in diagonal distance between corners = $1/2"$

Lateral error in top plate = $\pm 1/4"$

Error in top plate elevation (roll) = $\pm 1/4"$

7.3 Ridge Line Connection

In its attachment at the ridge line the panel element is subjected to large uplift forces, downloads; shear loads, axial tension and compression forces in the longitudinal direction due to roof diaphragm or folded plate action.

Loads at Ridge Line (standard load case, Chapter 6)

Load along (parallel to) ridge line (longitudinal direction)	
divide by length of span to obtain shear	
pitch = 12/12 eave width = 36'	1685 lbs.
Download (vertical)	
pitch = 12/12 eave width = 36'	553 lb./ft.
pitch = 3/12 eave width = 36'	453 lb./ft.
Uplift (vertical)	
pitch = 12/12 eave width = 36'	396 lb./ft.
pitch = 3/12 eave width = 36'	161 lb./ft.

The thin faces of the panel are primarily designed to carry in-plane stresses; the core material to carry low shear stresses. Neither component of the sandwich panel is well suited for transferring concentrated loads. Attachment of the interior face to a rigid support along the ridge line would result in the face delaminating from the core or core failure due to the large corner reactions resulting from thermal gradients on a rectangular sandwich panel. A bolted connector through the depth of the core would require a large load spreading washer to prevent the compression failure of the core. Considering the large corner reactions due to thermal or hygroscopic slab behavior, the bolted connector solution appears impractical.

7.3.1 Edge Stiffener

A proposed solution of rectangular edge stiffeners inserted between and bonded to the panel faces provides a fastenable, high strength material. The edge stiffener is installed after the net shape part has been produced in the factory. After the panel element

is cut to a specified length from what could be a continuous production line, the core is routed out to accept the edge stiffener. The stiffener is adhered to the faces to collect in-plane shear forces and to tie the two faces together; adhered to the core, to provide continuous shear transfer. Ideally, the edge stiffener should be produced of a material having a coefficient of expansion near that of the face material. In the case of oriented strand board or waferboard face, a suitable edge stiffener material might be glulam, parallam, or laminated veneer lumber. All of these products have compatible thermal coefficients, high strength, high modulus, and dimensional stability (ease of insertion).

Examinations of thermal and hygroscopic behavior determined that substantial reactions are required to resist the two-way bowing of a rectangular sandwich panel simply supported along opposite edges (see Chapter 5). If the element employed to resist these reactions is not in line with the required direction of the reaction force (perpendicular to the panel), the required reaction forces are magnified. This geometric problem occurs at the the fold line of folded plate roofs where the required reaction force (perpendicular to the panel) is divided by the $\cos(90^\circ - (2.0)\alpha)$. These magnified reaction forces become critical for low pitched roofs. At the ridge line of ridge beam supported roofs the required reaction force exerted on the fastener is divided by the $\cos(\alpha)$, and becomes critical for steeply pitched roofs. A proposed solution of supporting the edge stiffener at two points removes the problem of resisting these magnified reactions generated by the thermal behavior of a two-way slab (see Figure 7-3). The thermal reaction forces are resisted internally by the edge stiffener and not transferred by the fastening system.

As a result of being supported at two points the edge stiffener functions as a girder in carrying the shear reactions from the one-way slab action of the panel elements to the fastening points (Figure 7-3). The optimal symmetric location of these two support points, in terms of minimizing moments, is at 0.25 the overall length from the edge stiffener end. The sandwich panel is analyzed and designed as spanning from the eave to ridge in one-

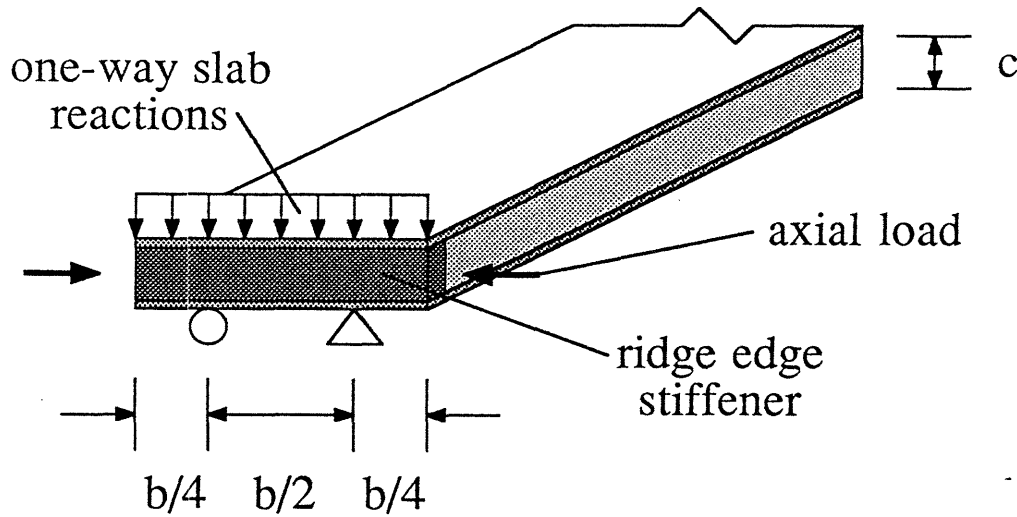

Figure 7-3: Edge Fastener Location and Stiffener Loads

way slab action between two simply supported edges. The panel's true behavior is that of a one-way slab on elastic supports (the edge stiffener) resulting in a slight redistribution of moments and shears from the idealized design approach. The extent of this variation in the edge reaction is assumed to be insignificant, but needs to be investigated with the aid of the finite element analysis.

The edge stiffener resists the bending of thermal or hygroscopic bowing and the bending moment and shears of the edge reactions from one-way slab action to the two support points. Additionally, the ridge edge stiffener functions as a longitudinal line member in carrying the axial compression and tension loads due to roof diaphragm or folded plate action. Depending on the direction of the roof diaphragm loading, the ridge edge stiffener may be subjected to compression or tension loads. The net result is a combined axial and bending load criteria. The buckling mode of the edge stiffener approximates the ideal boundary conditions of a pin-ended column. Thus, the design buckling factor, K_e , is equal to one, and the effective length of the edge stiffener column is the panel width, b .

For axial tension and bending of wood or wood composite structures:

$$\frac{f_t}{F_t} + \frac{f_b}{F_b} \leq 1.0$$

and

$$\frac{f_b - f_t}{F_b} \leq 1.0$$

where,

- f_t = Actual unit stress in tension parallel to the grain (p.s.i.).
- F_t = Allowable unit stress in tension parallel to the grain (p.s.i.).
- f_b = Actual unit stress for extreme fiber in bending (p.s.i.).
- F_b = Allowable unit stress for extreme fiber in bending (p.s.i.).
- F'_b = Allowable unit stress for extreme fiber in bending, adjusted for beam depth by the following formula (p.s.i.).

If the depth of a rectangular sawn bending member exceeds twelve inches F'_b is:

$$F'_b = F_b(12/c)^{1/9}$$

For axial compression and bending of wood or wood composite structures:

$$\frac{f_c}{F'_c} + \frac{f_b}{F'_b - Jf_c} \leq 1.0 \text{ where,}$$

- f_c = Actual unit stress in compression parallel to the grain (p.s.i.).
- F'_c = Allowable unit stress in compression parallel to the grain, F_c , adjusted for buckling as determined by the column slenderness, b/c (p.s.i.).

$$J = \frac{(b/c) - 11}{K - 11}$$

where,

K is determined by column slenderness, and J shall not be less than zero nor greater than one.

For short columns (b/c of 11 or less):

$$F'_c = F_c$$

For intermediate columns (b/c greater than 11 but less than K):

$$K = 0.671 \left(\frac{E_c}{F_c}\right)^{1/2}$$

$$F'_c = F_c \left[1 - \frac{1}{3} \left(\frac{b/c}{K}\right)^4\right]$$

For long columns (b/c of K or greater):

$$F'_c = \frac{0.30 E_e}{(b/c)^2}$$

When machine stressed lumber is used (short columns are designed as previously described):

For intermediate columns:

$$K = 0.792 \left(\frac{E_c}{F_c}\right)^{1/2}$$

For long columns:

$$F'_c = \frac{0.418 E_e}{(b/c)^2}$$

If supports are located at the quarter points of the edge stiffener the allowable unit horizontal shear stress, F_v , shall not exceed the actual horizontal shear, f_v , in a prismatic member:

$$f_v = \frac{15 V_e b}{32 t_e c}$$

where,

V_e = Vertical panel edge reaction at the eave edge stiffener (lb./in.).

t_e = Thickness of the edge stiffener (in.).

The maximum moment on the edge stiffener due to girder action is:

$$(M_e)_{max} = \frac{V_e \cos(\alpha) b^2}{32}$$

The maximum transverse deflection of the edge stiffener due to girder action is:

$$(w_e)_{max} = \frac{11 V_e \cos(\alpha) b^2}{768 E_e I_e}$$

An example of edge stiffener proportioning for a laminated veneer lumber (LVL) follows. LVL has the following material properties allowing for ICBO acceptance:

$$F_t = 2300 \text{ (p.s.i.)}$$

$$F_b = 2800 \text{ (p.s.i.)}$$

$$F_c = 2200 \text{ (p.s.i.)}$$

$$F_v = 250 \text{ (p.s.i.)}$$

$$E_e = 2,000,000 \text{ (p.s.i.)}$$

Example edge stiffener calculations are made to compare a four and eight foot panel width under a very severe load case and geometry. The core thickness shall be assumed equal to eight inches. A maximum axial load of 19,160 lbs. will be considered acting in compression. This load results from a folded plate pitch of 6/12 and a span of 40-feet. A maximum axial tension load of 5,676 lbs. will be considered. This value is found for the roof diaphragm behavior of a ridge beam roof system with a pitch of 12/12 and a length of 40 feet. A vertical edge reaction of 453 lb./ft. results from a 40 p.s.f. live load, 10 p.s.f. dead load, the critical wind and seismic loadings described in Chapter 6, a 3/12 pitch, and an eave to eave width of thirty-six feet.

The face material is unknown, and is not considered effective in edge stiffener bending, but does offer lateral restraint to edge stiffener bending (ie. no slenderness factor applied, even though beam depth exceeds its breadth). The degree to which the face material participates in edge stiffener bending, or the effective flange area, is dependent on the material properties and thickness of the faces. Therefore, the moment of inertia of the edge stiffener is conservatively:

$$I_e = t_e (c)^3/12$$

and,

$$f_b = \frac{3 V_e \cos(\alpha) (b)^2}{16 t_e (c)^2} = \frac{3 (453) \cos(14^\circ) (48)^2}{16 t_e (8)^2} = 2966.5/t_e \text{ (p.s.i.)}.$$

For a four foot panel width b/c is equal to 6.

$$F'_c = F_c = 2200 \text{ (p.s.i.)}.$$

For axial tension and bending:

$$\frac{f_t}{F_t} + \frac{f_b}{F_b} = \frac{5675}{2300 t_e 8} + \frac{2966.5}{t_e 2800} = 1.0$$

$$t_e = 0.73 \text{ (in.)}.$$

$$\frac{f_b - f_t}{F_b} = \frac{2966.5/t_e - 5675/(t_e 8)}{2800} = 1.0$$

$$t_e = 0.81 \text{ (in.)}.$$

For axial compression and bending:

$$\frac{f_c}{F_c} + \frac{f_b}{F_b} = \frac{19,160}{2200 t_e 8} + \frac{2966.5}{t_e 2800} = 1.0$$

$$t_e = 2.15 \text{ (in.)}.$$

A check for shear:

$$f_v = \frac{15 V_e b}{32 t_e c} = \frac{15 (453) 4}{32 (2.15) 8} = 49.4 \text{ (p.s.i.)}.$$

The final thickness of the edge stiffener is 2-1/4", resulting in a cross sectional area of 18.0 square inches. This case represents the most severe loads that are likely to be encountered, the most critical roof geometry, and a lower minimum of panel core depth. A twelve inch core results in a cross sectional area of 6.0 square inches, due to a more efficient flexural section.

Note that because the face material is not known, the bending stresses due to

thermal or hygroscopic gradients and the effective flange area of the panel faces have not been included in these sample calculations.

For an eight foot panel width b/c is equal to 12. The core depth remains at eight inches.

$$f_b = \frac{3 V_e \cos(\alpha) (b)^2}{16 t_e (c)^2} = \frac{3 (453) \cos(14^\circ) (96)^2}{16 t_e (8)^2} = 11,866/t_e \text{ (p.s.i.)}$$

$$K = 0.671 \left(\frac{E_c}{F_c}\right)^{1/2} = 0.671 \left(\frac{2,000,000}{2200}\right)^{1/2} = 20.23$$

$$F'_c = F_c \left[1 - \frac{1}{3} \left(\frac{b/c}{K}\right)^4\right] = 2200 \left[1 - \frac{1}{3} \left(\frac{12}{20.23}\right)^4\right] = 2109 \text{ (p.s.i.)}$$

For axial tension and bending:

$$\frac{f_t}{F_t} + \frac{f_b}{F_b} = \frac{5676}{2300 t_e 8} + \frac{11,866}{t_e 2800} = 1.0$$

$$t_e = 4.55 \text{ (in.)}$$

$$\frac{f_b - f_t}{F_b} = \frac{11,866/t_e - 5676/(t_e 8)}{2800} = 1.0$$

$$t_e = 3.98 \text{ (in.)}$$

For axial compression and bending:

$$J = \frac{(b/c) - 11}{K - 11} = \frac{12 - 11}{20.23 - 11} = 0.0494$$

$$\frac{f_c}{F'_c} + \frac{f_b}{F'_b - J f_c} = \frac{19,160}{2109 t_e 8} + \frac{11,866/t_e}{2800 - 0.0494(19,160/(t_e 8))} = 1.0$$

$$t_e = 5.41 \text{ (in.)}$$

A check for shear:

$$f_v = \frac{15 V_e b}{32 t_e c} = \frac{15 (453) 8}{32 (5.41) 8} = 39.3 \text{ (p.s.i.)}$$

Increasing the panel width to eight feet results in a edge stiffener thickness of 5-1/2", resulting in a cross sectional area of 44.0 square inches. The net result of the panel width increasing from four to eight feet is a 244% increase in edge stiffener cross sectional

area. This comparison does not consider the effect of thermal or hygroscopic bowing. It is important to note that these edge stiffener proportions are for a very severe load case, roof geometry and core depth.

7.3.1.1 Edge Stiffener Summary

In summary, edge stiffeners:

1. are made of a material with a coefficient of thermal expansion near that of the face material.
2. provide a fastening material.
3. act as a shear diaphragm strut collector by tying the opposite faces of the panel together.
4. are designed as a girder to support the one-way slab action of the panel spanning from the eave to ridge line.
5. are designed as a column to carry the compression and tension loads of a longitudinal line member; resist bending moments due to roof diaphragm or folded plate action.
6. are designed as a beam to resist thermal bowing.
7. remove the problem of resisting large corner uplift reactions generated by the thermal behavior of a two-way slab. If the edge stiffener is supported at two points, the thermal reaction forces are resisted internally by the edge stiffener and not the fastening system.

7.3.2 Ridge Edge Fastener

The ridge edge fastener design, shown in Figure 7-4, is the result of numerous demands. The ridge edge fastener is a hinged connection to rotate to any pitch. A pitch specific ridge fastener would add to the roof fastening accessory inventory, and limit roof angles to standard pitches. Therefore, a universal ridge hinge has been developed. The edge fasteners are attached in the factory, and the panels are shipped to the site in a hinged panel configuration. The interior surfaces of the panels face one another, and are thereby protected from damage. The edge fasteners can be easily detached and re-attached should re-alignment be required in the field. The fasteners provide two discrete points of attachment by the crane hooks. A crane deployment sequence is addressed in a later

section. The ridge edge fastener can be utilized in a folded plate, tied floor, or a ridge beam structural system. In the folded plate and tied floor system, the ridge edge fastener transfers downloads and wind uplift from one panel element to the other.

7.3.2.1 Separation Block

The addition of a separation block (Figure 7-4) which is attached to the hinge fastening plates before the ridge edge fastener is joined to the panel pairs has several attributes. The interior faces of the panel element are separated to allow fastening of the hinge to the ridge beam and access for crane hook attachment. The separation blocks also facilitate assembly of the hinged panel units (see Figure 7-5). Edge stiffeners are inserted in the panel element before the eave edge fasteners are attached to the edge stiffener. Separation blocks are adhered to the interior panel faces. The interior hinge fastener plate (Figure 7-4) is mechanically fastened to the edge stiffener face, and the weight of the upper horizontal panel element clamps the assembly together while the glue sets. The separation block also distributes the concentrated load of the ridge edge fastener over the area of the adhered block surface to prevent stress concentrations in the interior panel face. Separation of the two interior faces removes the possibility of damage of the interior finish surfaces by particle abrasion or stresses normal to the finished faces arising from transportation impact loads.

The separation block has the following disadvantage on the assumption that shipping is controlled by volume and not weight limitations: panel separation increases transportation costs. For example, a panel depth of 12 inches and a panel separation of 1.5 inches results in a 6.25% increase in transportation costs.

The dimensions of the separation block can be determined as follows. The minimum longitudinal length of the separation block is determined by the allowable in-plane stress for the face material. The separation block longitudinal length can be conservatively calculated as the bearing area of one face required to carry the maximum

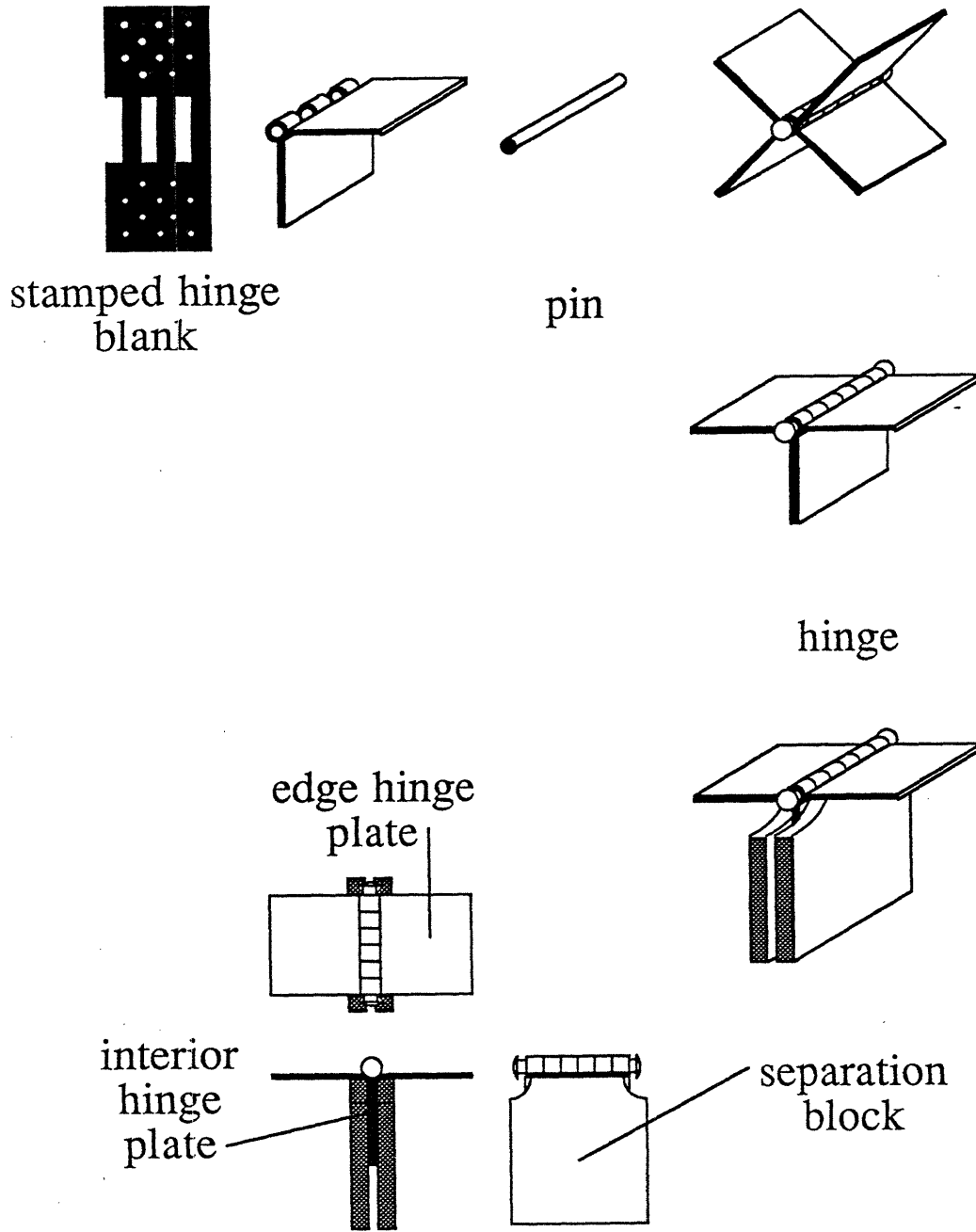

Figure 7-4: Ridge Edge Fastener

in-plane load carried by the ridge edge fastener as a result of transferring downloads or

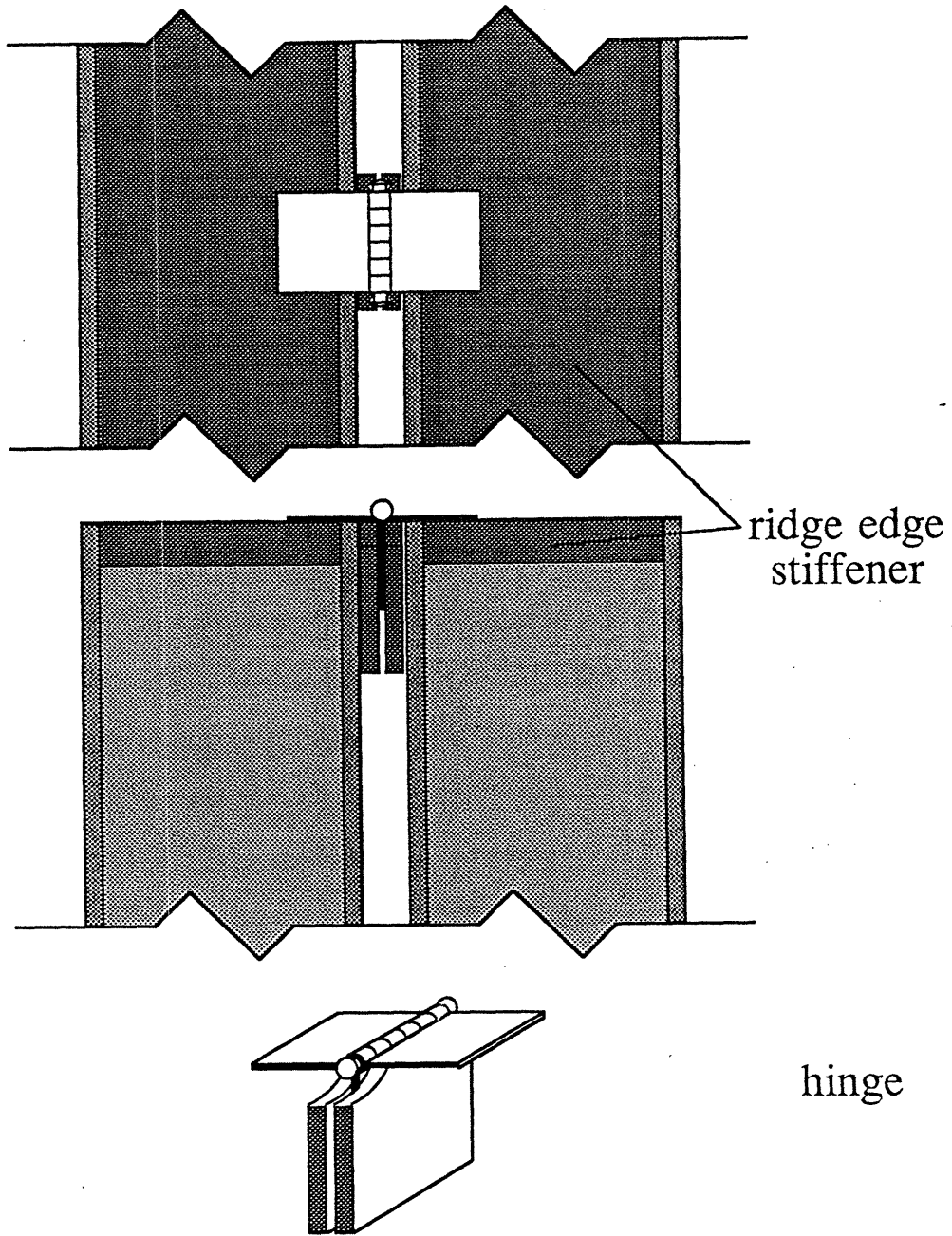

Figure 7-5: Hinged Panel Units with Ridge Edge Fastener

uplift across the fold line discontinuity divided by the face thickness. The transverse

width of the separation block is determined by the adhesion area required to transfer these forces into the face with an adequate factor of safety (7.0). The constraints on block thickness are determined by the depth penetration requirements for the mechanical fastener attaching the hinge plate to the separation block, as well as the geometry of the eave edge fasteners. To facilitate crane attachment the area adjacent to the hinge pin ends must be chamfered.

7.3.2.2 Ridge Beam Accessories

In the ridge beam system, a secondary accessory, referred to as a shoe, transfers loads to the ridge beam (refer to Figure 7-6). The shoe is a symmetric, prismatic trapezoidal element with two faces forty-five degrees to the vertical. With such a geometry, a shoe can accommodate any slope roof up to a 12/12 pitch. The shoe accessories are, however, specific to ridge beam widths (standard width is 3-1/2" and 5-1/4"). The top edge of the shoe is concave to mate with the barrel of the hinge. The material chosen for these shoes must be of a strength capable of resisting the download of the ridge edge fastener over the contact area of the hinge barrel with the shoe. Given the standard load case, a pitch of 12/12 and an eave width of 36 feet, the down load on the shoe for a panel element four feet wide is 2212 lbs. and 4424 lbs. for an eight foot panel element width.

The trapezoidal shoes are attached to the ridge beam before installing the beam on the roof. The trapezoidal shoes are aligned precisely with the center line of the ridge beam. This alignment process is aided by the width of the shoe being equal to the ridge beam width. The longitudinal positioning of the shoes need not be so precise. The length of the shoe is extended beyond the required length for the ridge edge fastener to allow for uncertainty in positioning the shoe in the longitudinal direction, lack of control in precise positioning of the panel during deployment, and to allow the panel element to slide in the longitudinal direction when butting adjacent panel elements together. For ease of

assembly the shoes could be coated with a lubricant in the factory to reduce friction between the metal barrel of the hinge and the shoe.

The shoes separate the panel from the ridge beam. If the panel were placed directly against the ridge beam any outward thermal or hygroscopic bowing would create a thin but noticeable gap. By widening the gap to create a reveal, the differential in gap thickness is less noticeable. Furthermore, if the panel were in direct bearing on the ridge beam the restraint of the beam to inward bowing would exert substantial uplift reactions on the edge fasteners.

The shoe is held to the ridge beam by a pre-formed and pre-stamped light gauge metal strap plate which is placed over either end of the shoe (refer to Figure 7-6). Nailing the metal strap to the ridge beam and not to the shoe allows the panel elements, which are attached to the shoe, to shift in relation to the ridge beam due to differential thermal movement between the roof panel and ridge beam in the longitudinal direction. The ridge beam is dimensionally stable in the controlled environment of the house interior. The roof panels are subjected to thermal expansion, contraction and moisture changes, if vapor drive is not properly controlled.

The ridge edge fastener is clamped down to the shoe by a ductile iron component which is flat on one side and concave on the other to mate with the radius of the ridge edge fastener hinge. This accessory is referred to as a hold-down in Figure 7-6. Holes are placed at either end for the passage of two lag screws to resist the wind uplift at the ridge line.

In the ridge beam system, field connections are limited to the attachment of shoes to the ridge beam while the beam rests on the ground and the installment of four lag bolts per hinged panel unit, after placed on the roof.

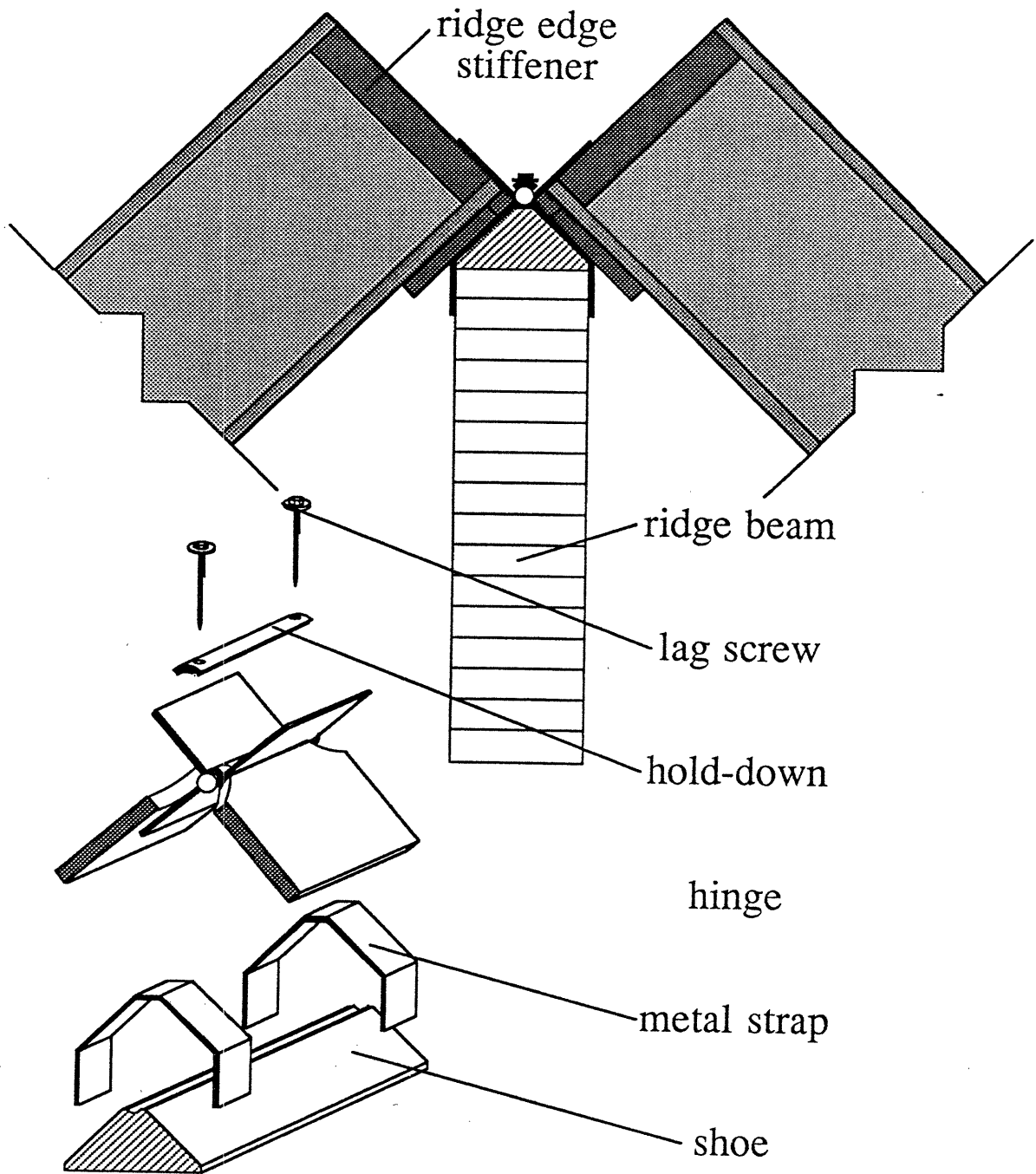

Figure 7-6: Ridge Beam Ridge Line Connection

7.3.2.3 Folded Plate and Floor Tied Ridge Edge Fastener

In the folded plate and tied floor system there are no field connections at the ridge line (see Figure 7-7). The hinge transfers downloads, wind uplift, and shear in the longitudinal direction from one edge stiffener to the adjacent edge stiffener.

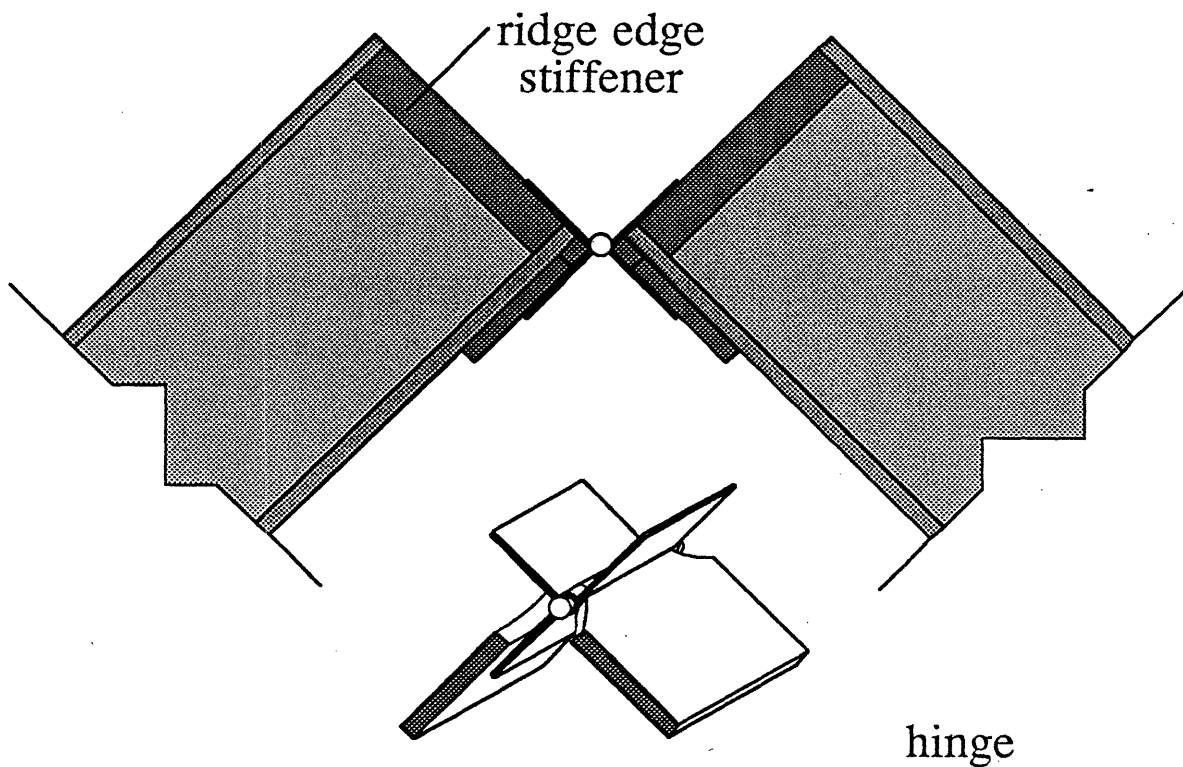

Figure 7-7: Folded Plate and Floor Tied Ridge Line Connection

In the folded plate and tied floor system a negative moment is induced on the panel element due to eccentricity of the ridge edge fastener. The moment is at a maximum at the ridge connection and decreases linearly to zero at the eave connection. Given a ridge edge fastener eccentricity of six inches, and a in-plane load of 1878 lb./ft. (resulting from the standard load case described in Chapter 6, a 3/12 pitch, and an eave to eave width of thirty-six feet) the resulting maximum negative moment is 934 lb.ft.. To establish a

reference of comparison, a panel element length of 12'-3" would result in an equal positive maximum moment due to one-way slab action under the same transverse loading. The opposite sign of these superimposed moments diminishes the effect of the fastener eccentricity. In the above loading case, bending stress levels and deflections are decreased by the eccentricity. Superimposing the negative moments due to the eccentricity with the outward wind pressure does not have this beneficial effect. A check regarding stresses and deflection must be performed for this loading condition.

7.3.2.4 Preliminary Hinge Design

The hinge design is performed according to the Cold-Formed Steel Design Manual [A.I.S.I., 83], in conjunction with the Manual of Steel Construction [A.I.S.C., 87]. An example hinge design for a four foot panel width (standard load case of Chapter 6) follows:

In service loads are multiplied by a factor of 2.0 (F.S.), to arrive at an equivalent safety factor of 3.0 (assuming that a minimum safety factor of 1.5 is applied to general steel design).

The loads for the crane are determined as 1.25 times the total load, where the total load includes an impact factor [U.B.C., 88]. A conservative impact factor of 2.0 is chosen. Assuming a panel weight of 10 p.s.f., and a panel length of 25 feet, the dead load per ridge edge fastener is 1000 lbs.. The resulting design load is 2500 lbs. per ridge edge fastener, or 1250 lbs. acting on the shear area of the pin. Multiplied by a factor of safety of 2.0, yields a design shear load of 2500 lbs..

Given the standard load case of Chapter 6, a 3/12 pitch, and an eave width of 36 feet, the vertical download on the ridge edge fastener is 453 lb./ft. and 553 lb./ft. for a pitch of 12/12. The maximum in-plane load collected along a two foot ridge line length is 1868 lb./ft.. The resulting shear across the hinge pin is twice this value, 3736 lbs.. After

multiplication by the service factor of safety (2.0), the resulting maximum in-plane design load to be carried by shear across the hinge is 7472 lbs.

The number of knuckles per hinge is determined by the comparing crane deployment loads to in-plane loads which the hinge resist after its deployment. The number of hinge knuckles should be an even number so that the hinge half can be manufactured out of the same stamped steel plate blank (see Figure 7-4). The shear area for in-plane loads is equal to the pin cross-sectional area multiplied by the number of knuckles per hinge minus one. The shear area for the crane attachment is equal to two times the pin area. The number of knuckles is that which best approximates:

$$\begin{aligned} \text{number of knuckles per hinge} &= (1 + 2(\text{in-plane load/crane load})) \\ &= (1 + 2(7472/2500)) = 7 \end{aligned}$$

Since pin diameter is not critical, a six knuckled hinge is chosen.

If the steel selected for the pin is a A490 steel with an allowable shear value of 40 k.s.i., the required diameter of the pin to carry in-plane loads is 0.25 inches. If the steel selected for the pin has a minimum tensile strength of 70 k.s.i., the allowable shear is 15.4 k.s.i., and the resulting diameter is 0.375 inches. Depending on the thickness and workability of the hinge plate steel, a larger pin diameter might be desired.

The loads on the hinge plates are conservatively determined by assuming that the hinge plates can only resist forces which lie in the plane of the hinge plate. These lateral loads are described as either a pull or push. Pull loads rely on the hinge plate being wrapped around the pin to transfer loads into the hinge plate (Figure 7-8). In push loads the pin directly bears on the hinge plate (Figure 7-9).

The hinge plate which is attached to the interior of the panel is referred to as the interior hinge plate; the hinge plate which is attached to the ridge edge stiffener is referred to as the edge hinge plate (Figure 7-4).

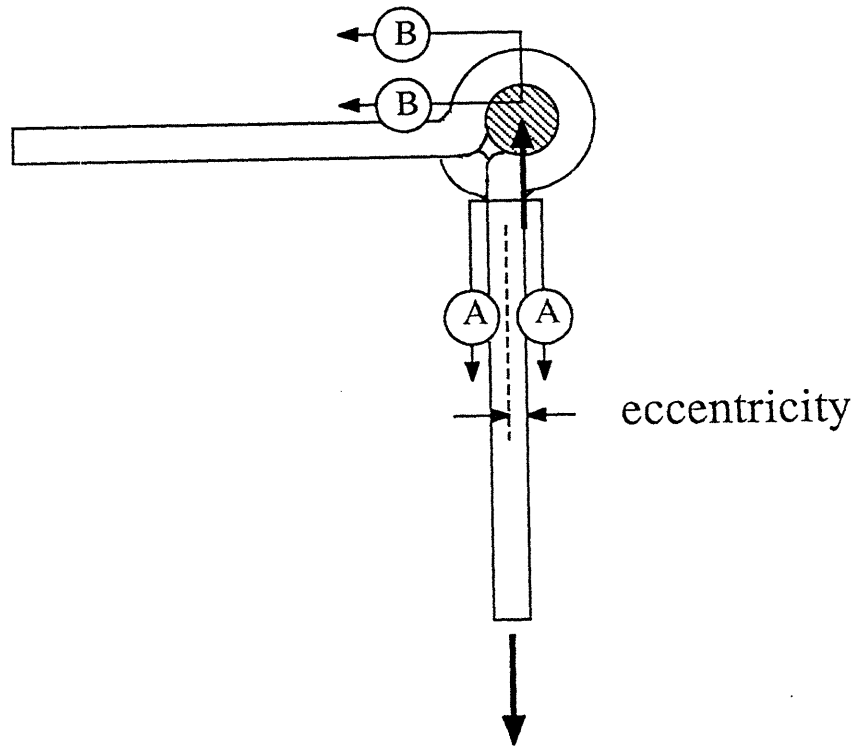

Figure 7-8: Pull Loads on the Hinge Plate Section

The maximum pull design load for the interior hinge plate is found by comparing the crane load (Figure 7-10-a), a pull load of 2500 lbs. (includes safety factor), to the maximum pull load equal, $F.S. V_r b \cos(\alpha)/2.0$, resulting from a ridge beam system (Figure 7-10-b). A V_r of 453 lbs./ft. (a pitch of 3/12 and an eave to eave width of 36), collected over a two foot length and multiplied by a safety factor of 2.0, yields a pull load equal to 1760 lbs. In this case, the crane pull load of 2500 lbs. controls.

The maximum push load to be resisted by the interior hinge plate is determined by examining the loads which result in transferring the downward thrust of the panel edge stiffener in a folded plate system, $F.S. V_r b/(2.0 \sin(\alpha))$ and subtracting out the pull load of

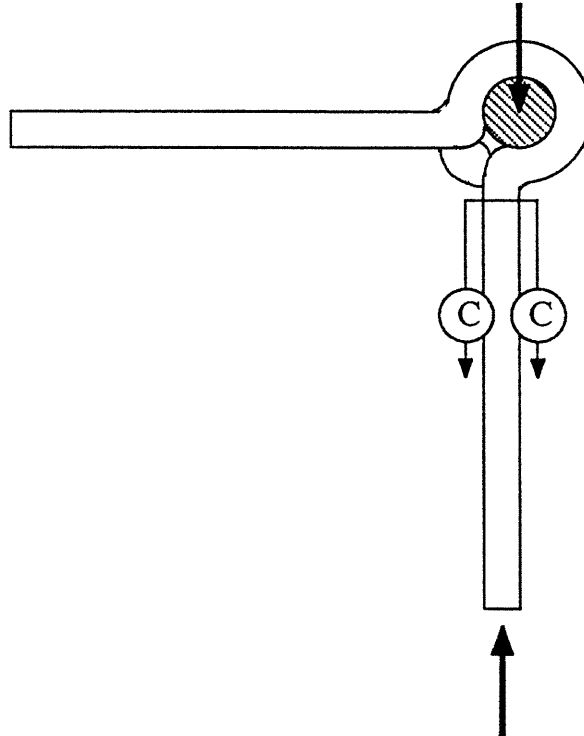

Figure 7-9: Push Loads on the Hinge Plate Section

transferring the panel edge reaction, $F.S. V_r b \sin(\alpha)/2.0$ (Figure 7-10-c). The maximum interior hinge plate load is 7032 lbs. for the case of a 3/12 pitch and an eave to eave width of 36 feet.

The maximum pull load on the edge hinge plate (Figure 7-10-b) is found by $F.S. V_r b \cos(\alpha)/2.0$, which has a maximum value of 1760 lbs. at a pitch of 3/12 and an eave to eave width of 36 feet.

The maximum push load on the edge hinge plate is found by $F.S. V_r b \cos(\alpha)/2.0$, where the edge stiffener reaction is the wind uplift (reverse force directions of Figure 7-10-b). This load has a maximum value of 1148 lbs. at a pitch of 12/12 and an eave to eave width of 36 feet.

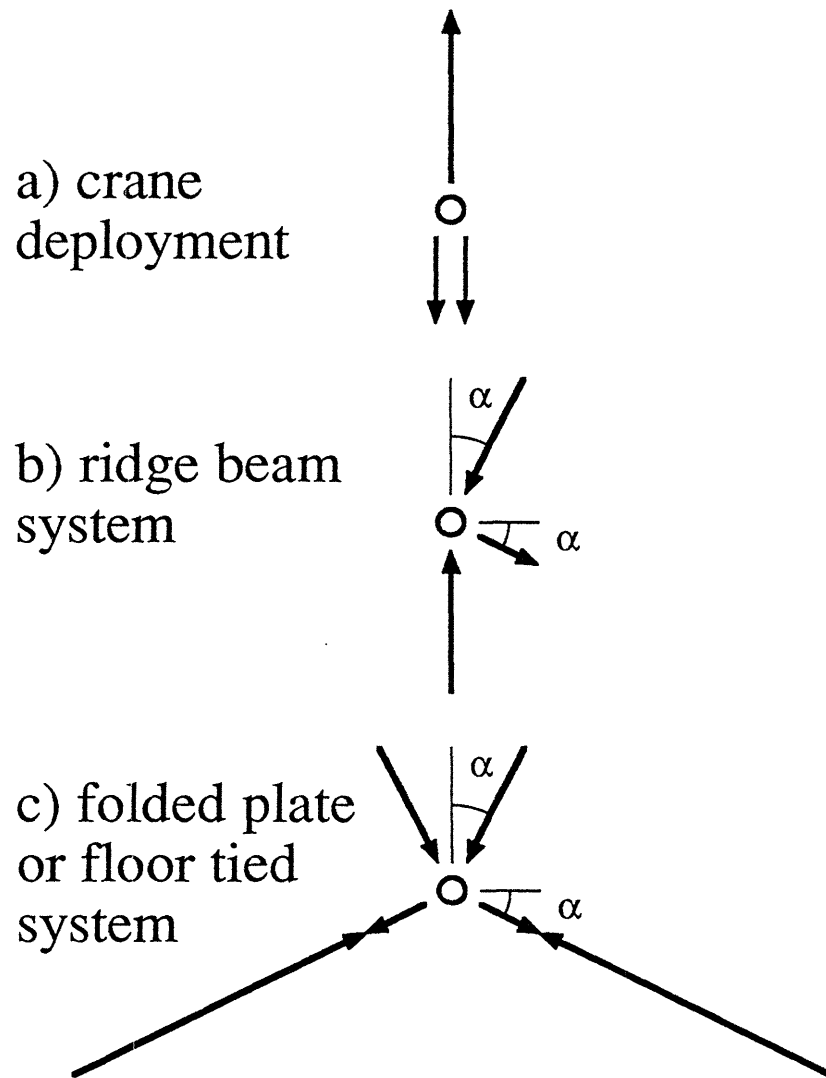

Figure 7-10: Hinge Load Forces

Since the pull and push loadings are carried in identical action for either the interior or edge hinge plate, only the most critical load need be examined. The most critical push load is 7032 lbs.; the most critical pull load is 2500 lbs.

The steel chosen for the hinge plates is a A606 hot-rolled and cold-rolled high strength low-alloy sheet or strip steel with improved corrosion resistance [Yu, 85]. The yield strength of the A606 is 50 k.s.i. and the minimum ultimate strength is 70 k.s.i.. The

allowable flexural and tension stress in the steel is 0.6 of the yield strength, or 30 k.s.i.. The attachment of the hinge plates to the edge stiffener and the separation block by screws is assumed to prevent localized crippling or buckling of the hinge plates. Therefore, the allowable compression stress is assumed to be 0.6 of the yield stress. The allowable shear is 0.4 of the yield strength, or 20 k.s.i..

The pull load is designed by conservatively assuming that forces are transmitted into the interior plate by the hinge plate acting as an a loop bent around the hinge pin (Figure 7-8). The interior and edge hinge plate are welded together at the point of near contact. The critical sections to be designed for are a cut through section A-A for a combined flexural bending and tension criteria, and a cut through the shear plane of the hinge plate at section B-B of Figure 7-8. The maximum pull load due to crane loads is 2500 lbs.

The eccentricity of the pull load on the interior hinge plate is equal to one-half the thickness of the hinge plate (Figure 7-8). The resulting bending moment is equal to the eccentricity times the pull load or 0.0625 inches times 2500 lbs., 156.25 lbs.in.. The axial tension and bending criteria [A.I.S.C., 87] is:

$$\frac{f_t}{F_t} + \frac{f_b}{F_b} \leq 1.0$$

An 5.0 inch wide, 0.125 thick hinge plate satisfies the constraints:

$$\frac{2500}{0.125 (2.75) 30,000} + \frac{156.25 (6)}{0.125^2 (2.75) 30,000} = 0.97$$

The required shear area at section B-B (assuming a parabolic stress distribution) is 3 (1250 lbs.)/(2 (20,000 p.s.i.)) or 0.094 inches². A effective hinge plate width of 2.75 in. and a thickness of 0.125 in. satisfies this constraint (area equals 0.344 in.²).

The push load is designed by considering that the minimum section through the hinge plate be able to transfer forces though bearing on the pin (section C-C of Figure 7-9). The edge stiffner, separation block and adjacent hinge plate restrain the bending of

the hinge plate due to the eccentricity of load. The minimum effective area is equal to 7032 lbs./30,000 p.s.i. or 0.2344 inches². A effective hinge plate width of 2.75 in. and a thickness of 0.125 in. satisfies this constraint.

The hinge plate depth is controlled by the fastening schedule. The greatest pull or push load determines the number of fasteners for the hinge plate. Allowable loads for fasteners include a factor of safety. Thus the maximum loads for the interior hinge plate of 7032 lbs. is divided by the safety factor to result in a fastener design load of 3516 lbs.; likewise, the edge hinge plate a load of 1760 lbs. is reduced to 880 lbs. If the separation block is of a material comparable to a Group I wood, and of a thickness of 1.0 inches, the allowable lateral load for a 14 gage screw penetrating four times its diameter (0.968 inches) is 160 lbs. [U.B.C. Standards, 88]. Eleven screws would be required on the interior plate hinge; six screws on the edge hinge plate. Not considered in the preliminary fastening schedule are the loads along the ridge line (longitudinal direction) due to wind and seismic roof diaphragm behavior.

7.3.2.5 Redundant Ridge Edge Fastener

The folded plate is a non-redundant structure. Failure of any one critical component of the folded plate structure results in the sudden collapse of the entire roof system. A moment rigid ridge edge fastener could provide redundancy for the folded plate. Given a moment rigid ridge connection, and adequate panel strength, the panels could span from eave to eave, simply supported. Spanning from eave to eave rather than from eave to ridge line, as in the folded plate, increases moments by a factor of four; shear stresses by a factor of two. Typically, sandwich panel design is controlled by stiffness; not strength constraints. The strength requirements of this system may be met with little or no increase in demands on practical panel design.

The proposed moment rigid ridge fastener is a modification of the previous ridge fastener (refer to Figure 7-11). The transfer of large tension and compression forces

across the panel faces is achieved by the addition of a compression member (referred to as a strut), and extending the length of the hinge plate attaching to the ridge edge stiffener (referred to as the edge hinge plate) to the exterior face of the panel element. The edge hinge plate resolves the vertical component of the compressional and tension loads in the panel faces. The strut fits loosely between the bent outer edges of the edge hinge plates. The strut is slipped into the redundant ridge edge fastener after the hinged panel unit has been deployed, and is mechanically fastened to the hinge plate by one or two nails to prevent it ever working free. By hinging the strut at one end to a edge hinge plate in the factory, the strut would slide into its final position as the panels are deployed and splayed apart. As an accessory piece, the geometry of the compression strut is dependent on the pitch of the roof. The fabrication of this element is relatively straight forward. The length and bevel of the edge are the only variables in the strut's proportions. The compactness of the strut dimensions reduces storage demands.

The length of the redundant ridge edge fastener is extended in the longitudinal direction as compared to the previous ridge edge fastener. This stretching of the ridge edge fastener geometry spreads the sizable tension and compression loads into a larger net area of the panel faces. The strength capabilities of the panel faces may require that reinforcement be added to faces in the region of the redundant hinge to decrease the stresses.

Only after folded plate failure would the redundant ridge edge fastener catch the load after a substantial drop in ridge line elevation. The physical dropping of the ridge line would serve as an indicator to the homeowner that a failure in the folded plate has occurred.

Given an eave to eave distance of 36 feet, a horizontal projected live load of 40 p.s.f., and a horizontal projected dead load of 15 p.s.f., the resulting moment at the ridge line per linear foot is 8910 lbs. If the panel element width, b , is four feet, the moment

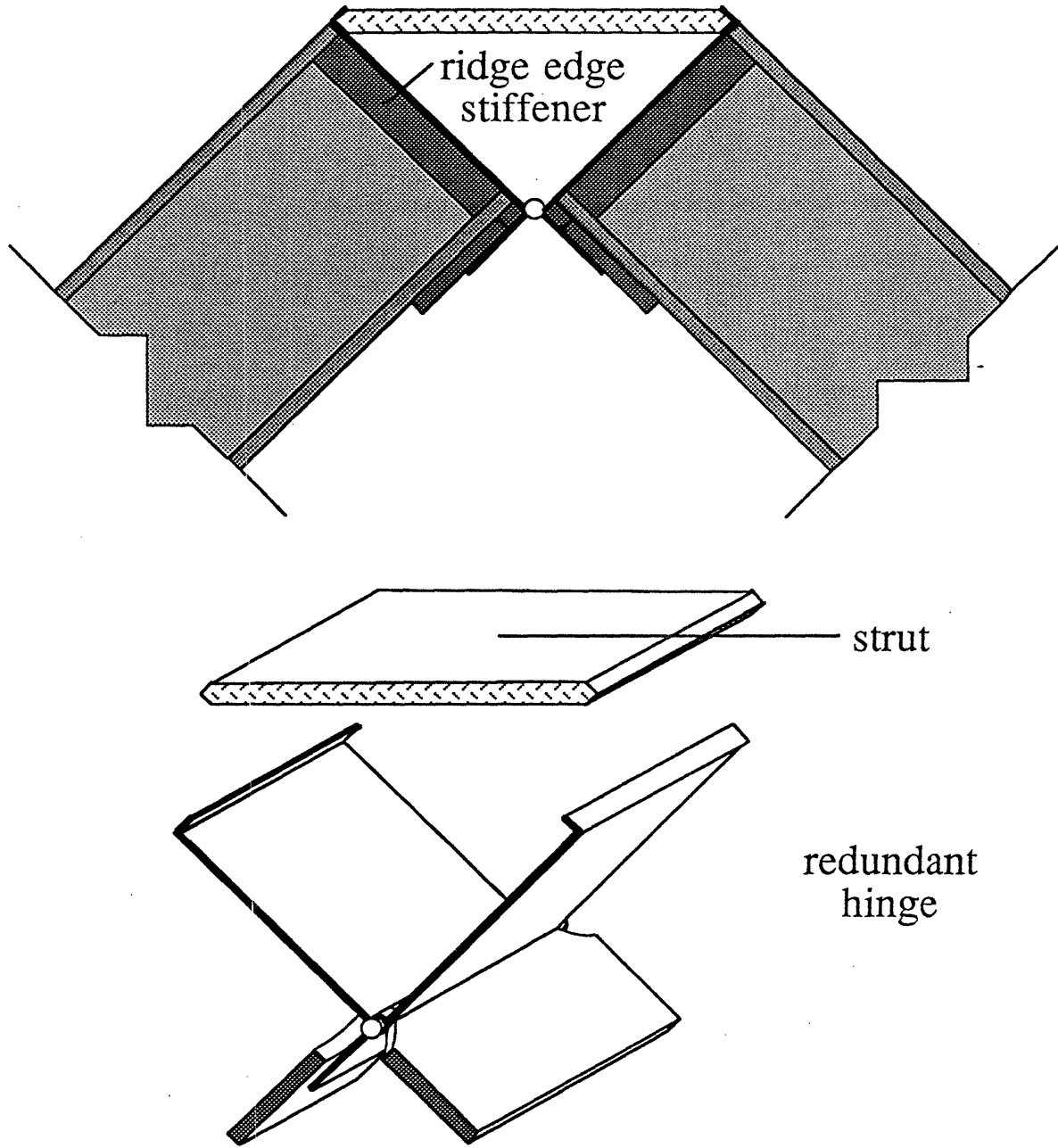

Figure 7-11: Redundant Ridge Edge Fastener

carried by each redundant ridge edge fastener is 17,820 lb.ft. If the distance between

centerlines of the sandwich panel faces, d , is assumed as one foot, the axial tension and compression load on the faces is 17,820 lbs. The compressive load in the strut is equal to $\cos(\alpha) + \sin^2(\alpha) / \cos(\alpha)$ times the load on the faces, where α , is the angle between the roof surface and the horizontal. The maximum compressive strut force of 25,200 lbs. occurs for the maximum roof pitch of 12/12. The tension load on the edge hinge plate is equal to $\tan(\alpha)$ times the load on the faces. This tensile load has a maximum value equal to the load on the faces, 17,820 lbs., for a pitch of 12/12.

7.3.2.6 Ridge Fastener Noise

Noise generated from the ridge fastener is a concern. This potential concern can be validated by the irritating problem of nail squeak resulting from dynamic loading in residential floors. Wind gust or vortex shedding can generate dynamic loading on a roof panel. The hinge is rigidly clamped to the shoe, preventing movement. If movement should develop over time, for instance, due to fastener stress relaxation, the lubricated metal to non-metal interface between the shoe and hinge should dampen acoustic vibrations. Likewise, the ridge beam and shoe interface should not present potential problem given the probable nature of their materials (wood or plastic on metal). The squeaking of the metal hinge due to vibratory movement is a major concern for sound generation. Coating the hinge pin with a teflon coating would reduce friction. Teflon washers placed between the hinge knuckles would prevent chattering and rubbing arising from dynamic flexing. A coating on the component which connects the ridge edge fastener to the shoe should again abate any noise problem.

7.3.2.7 Ridge Edge Fastener Summary

In summary, ridge edge fasteners:

1. provide attachment points for the crane hooks to deploy the roof panels.
2. connect edge stiffener of one panel to edge stiffener of adjacent panel, joining the discontinuity at the ridge line.

3. localize and limit the number of connections made in the field.
4. can be utilized in a ridge beam, folded plate, or tied floor system.
5. adjust in angle to any pitch.
6. can be pre-attached in the factory for shipping.
7. are easily detached and re-attached in the field if re-aligning is required.

7.3.3 Insulation

The triangular void between the edge stiffeners is a cold spot in the roof envelope which is also vulnerable to air infiltration. In the factory, a flexible adhesive tape is applied along the ridge line to seal the gap between the edge stiffeners and prevent air infiltration. Applying foam on site/in place with aerosol cans provides an insulating, air tight seal which has elastic properties to conform to the bowing of the edge stiffeners. Taping the gap between edge stiffeners prevents foam from falling through the crevice before hardening. The cost of filling the significant volume of the triangular void and CFC issues, however, make the use of polymer foam questionable.

$$\text{Void} = (\text{insulation depth})^2 \tan(\alpha)L$$

A roof length of 60 feet, a pitch of 12, and a foam depth of five inches results in a sizable void volume of 10.4 cubic feet. An alternative, and possibly more economical solution, is to use loose mineral wool, fiberglass batts or blown insulation. There exist the possibility of attaching the fiberglass batt insulation to the edge stiffener in the factory. The fiberglass batts would merge as the panel is deployed and splayed apart. This method removes the need for on site insulation installment.

7.3.4 Weather Sealing

A continuous ridge cap with integral rain screen overlapping the panel faces seals the area from water penetration. Additionally, the ridge cap could act as a container for insulation blown in from the ridge ends. The ridge cap is placed after the ridge edge fastener connections have been completed and inspected.

7.3.5 Edge Stiffener Tension Splice

Depending on the direction of the roof diaphragm loading, the ridge edge stiffener may be subjected to compression or tension loads. End bearing of adjacent edge stiffeners is able to transfer axial compression forces, however, the transfer of axial tension loads requires a tension splice.

If edge fasteners are located near the edge stiffener ends, the possibility of directly connecting the edge fastener of one panel with the adjacent edge fastener exists. Reasons not to pursue this joint concept are two fold: relocating supports from their more optimal location, at edge stiffener quarter points, increases edge stiffener dimensions; adding the duty of tension splice increases the demands on an already highly loaded ridge edge fastener.

The preliminary design of the tension splice is dependent on several factors. Plate connectors nailed or screwed in the field are a labor intensive job. Assuming an allowable lateral load of 280 lbs. per fastener (group III wood, size 18 screw, embedded to 1.876" [U.B.C. Standards, 88]) 136 screws are to be installed for a 19,160 lb. capacity tension splice. Gang-Nail connectors employed in wood truss tension splices can not be used in the field because of the large compressional forces required to drive them. Specially modified plate-type connectors, however, could be hydraulically driven into the edge stiffener in the factory, before the edge stiffeners are inserted into the panel edge. This accessory is referred to and labeled as a splice-nail in Figure 7-12. Integral to this plate-type connector are several reinforced threaded nuts, which are welded on the underside of the plate-type connector. Blind holes would be drilled into the edge stiffener to make room for the projecting nuts. A secondary accessory, referred to as a splice-plate and shown in Figure 7-12, joins the two edge stiffeners at the prepared end conditions. The steel splice-plate with slotted holes serves as a structural link in joining adjacent edge stiffeners. The slotted holes allow imprecise location of the splice-nail by taking up the

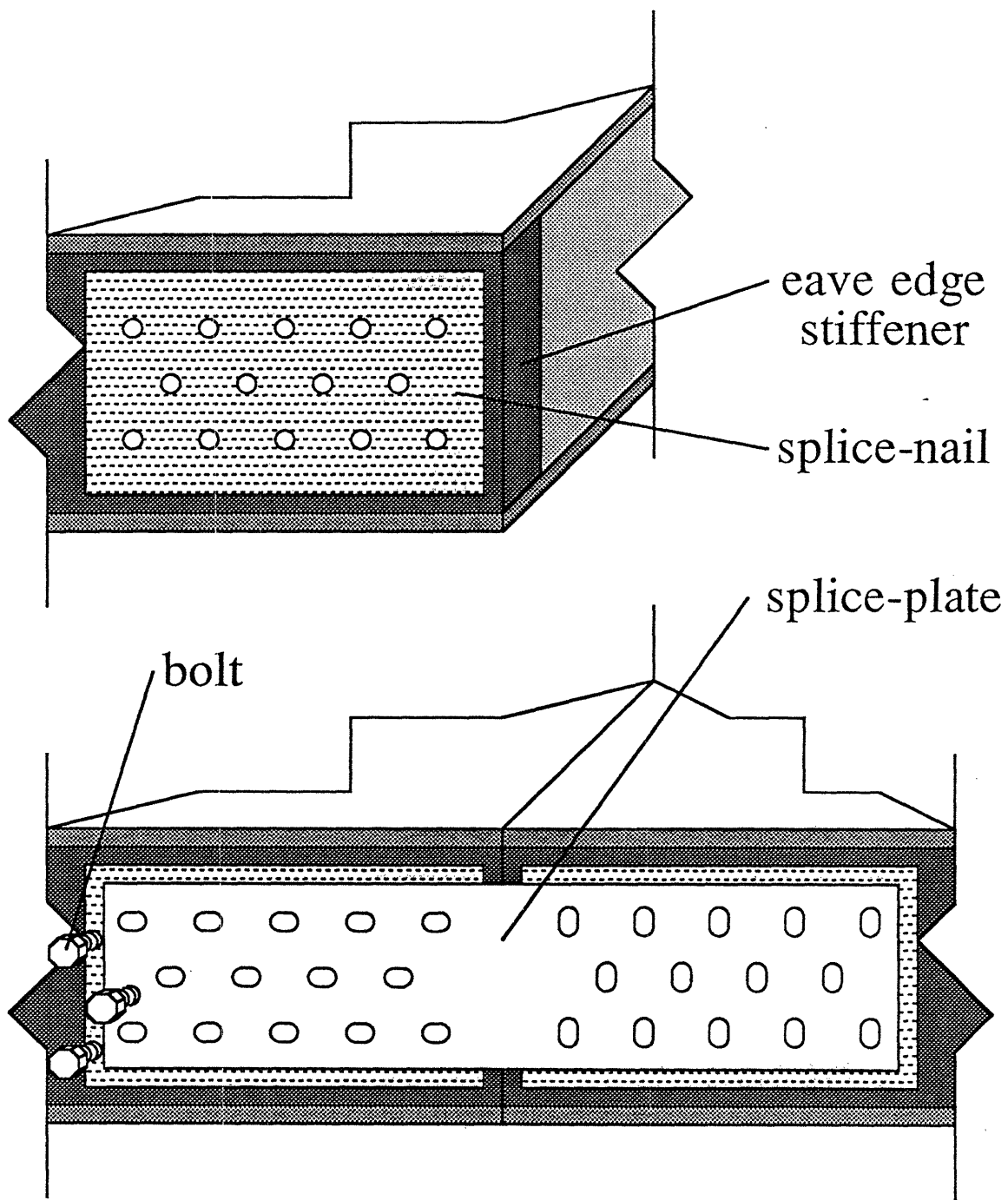

Figure 7-12: Edge Stiffener Tension Splice

play so that the two edge stiffeners are in direct contact to transfer compressional loads.

The holes are slotted at either end of the metal plate are slotted in orthogonal directions. The tie would be effective in resisting shear between the edge stiffeners which is normal to the roof panel. A special clamping tool might be developed to pull and temporarily hold the two edge stiffeners together during assembly so that the friction bolts can be tightened, without the joint alignment slipping.

The proposed tension splice has numerous benefits in constructibility and economy. The tension splice reduces the number of field connections from a large number for the nail driven fasteners to a small number of high strength metal to metal fasteners. The axial loads vary parabolically along the length of the folded plate or roof diaphragm. For greater economy, the capacity of the tension slices should be stepped down to reflect this variation in moment. The plate-type connector could be produced in a limited number of capacities, similar to the wood truss tension splices. Furthermore, the number of high strength connectors installed in the field could vary with the tension loads.

The proposed joint is prepared in the factory and is integral to the edge stiffener before insertion into the panel edge. A secondary accessory joins the two edge stiffeners at the prepared end conditions.

7.3.5.1 Tension Splice Summary

Tension splices are:

1. hydraulically pressed to the edge stiffener ends at the factory.
2. produced in varying load capacities.
3. joined together by a secondary accessory which is fastened by high strength friction bolts (where number installed depends on load requirements).

7.4 Longitudinal Wall Connection

Eaves are subjected to loads equal to or slightly greater than the ridge line connection.

Loads at Longitudinal Wall (standard load case, Chapter 6)

Load along (parallel to) longitudinal wall (longitudinal direction)

divide by length of span to obtain shear

pitch = 12/12 eave width = 36' 6741 lbs.

Download (vertical)

pitch = 12/12 eave width = 36' 553 lb./ft.

pitch = 3/12 eave width = 36' 453 lb./ft.

Uplift (vertical)

pitch = 12/12 eave width = 36' 406 lb./ft.

pitch = 3/12 eave width = 36' 197 lb./ft.

An edge stiffener is desirable at the eave line for the same reasons as at the ridge line: thermal and hygroscopic bowing, wind uplift resistance, shear strut collector, and longitudinal line member.

7.4.1 Eave Overhangs

Eave overhangs are a predominant feature of residential construction. Upon first examination, the obvious solution to eave overhangs with a panelized roof system is to cantilever the panel element over the longitudinal wall. Placement of an edge stiffener a distance in from the panel end during fabrication, however, adds great complexity to the panel production, particularly with continuous panel production. The problem of eave overhang can be solved in one of two ways. A structural roof accessory, which may include gutter, ventilation, insulation, soffit, fascia, and drip cap is attached to the eave edge stiffener, and the longitudinal wall. This accessory may be manufactured in the factory, roll-formed on the site (a technique presently employed for forming seamless gutters on the job site), or built as a boxed construction on the site. This accessory

solution to the eave detail provides maximum design flexibility and conforms to the increasing trend towards individualized and personalized home design. An alternative solution is to rigidly adhere a short length of panel onto the eave edge stiffener before inserting the eave stiffener into the routed panel element edge. The adhesion of the eave edge stiffener to the faces and the panel core in a controlled factory environment ensures a moment rigid, continuous connection able to resist the significant moments due to wind uplift ($C_q = 2.8$ upward). Difficulties encountered with this concept are:

1. Access to the eave edge stiffeners ends must be provided to connect the tension splices.
2. Overhanging panel physically interferes with the longitudinal wall connection.
3. Eave does not require insulation or such high strength capacities as provided by the overhanging sandwich panel element.
4. A secondary edge stiffener is required at the overhang edge to attach fascia, soffit and gutter.
5. Panel overhangs reduce the flexibility in customizing the eave detail.

7.4.2 No Eave Overhangs

In the case of no eave overhang, a beveled edge stiffener would have the desirable effect of creating an eave flush with the longitudinal wall, but would require complex millwork specific with each pitch. Fabrication considerations suggest that the edge stiffener be square to the panel element, and hence, be fabricated identical to the ridge edge stiffener.

Thermal and hygroscopic behavior of a two-way slab creates many difficulties at the eave connection. Due to the longitudinal wall not being aligned with the direction of the required thermal and hygroscopic edge reactions, these reaction forces are magnified by the division of the $\cos(\alpha)$ (problematic in steep roofs). Again, the proposed solution of supporting the edge stiffener at two points removes the problem of resisting large corner

uplift reactions generated by the thermal behavior of a two-way slab. The optimal location of these two support points, in terms of minimizing bending stresses, is at 0.25 the overall length from the end of each panel element. This finding is arrived at by examining various load cases. The case of a uniform load acting over the cantilever portion of the edge stiffener results in a moment equal to a uniform load acting over the span between supports only if the cantilever span is equal to one half of the span between the two support points.

As in the case of the ridge edge stiffener, the eave edge stiffener resists the bending caused by thermal or hygroscopic bowing, and the bending moment from transferring one-way slab action of the panel to two support points. Additionally, the edge stiffener carries axial tension and compression forces as a longitudinal line member. The net result is a combined axial and bending load criteria, Section 7.3.1.

7.4.3 Eave Edge Fastener

The requirements of a eave edge fastener are multifaceted.

The fastener needs to adjust in height to remove any variation in the longitudinal wall height (roll). This discrepancy in construction is typically in the range of plus or minus one quarter of an inch. The roll results from foundation inaccuracies and varying wall height, and should not be carried into the roof line where longitudinal wall height variations may effect the alignment and constructibility of panel to panel connections.

Another issue of constructibility is that of lateral thrust on the longitudinal wall. Unless a positive stop is provided for the panel element to engage the longitudinal wall in a pitched roof panel system, the wall may be pushed laterally inward, Figure 7-13. Wall kick out will occur if the longitudinal wall is not properly laterally braced and frictional forces between the roof panel and the wall are overcome. Lateral wall bracing, typically provided every six or eight feet during construction may deflect under this lateral thrust, which is not present in the deployment of wood trusses.

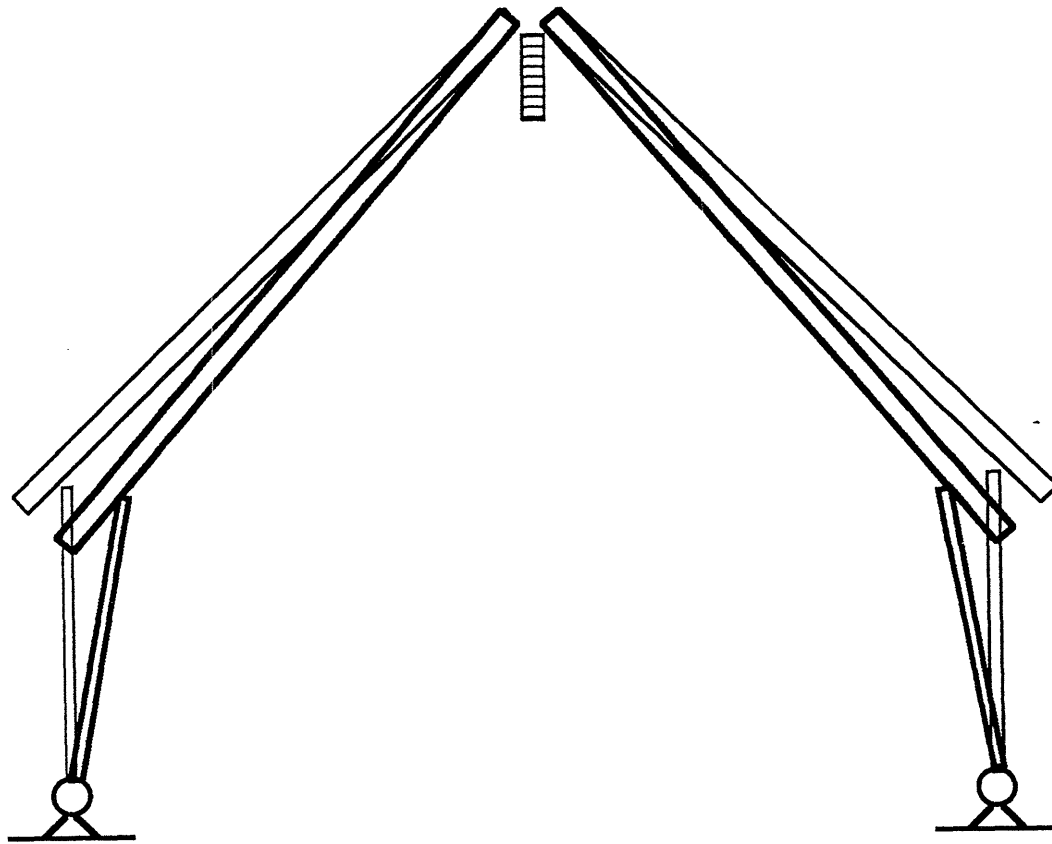

Figure 7-13: Lateral Longitudinal Wall Kick Out

The longitudinal wall is typically not designed to carry bending forces. The eave joint should not possess rotational stiffness, since an end moment placed on the edge wall decreases the axial load capacity. Another concern of the eave edge fastener is eccentricity. In the case of stud construction, an axial load deposited one and three-quarter inches off the centerline of a nine foot yellow pine stud (kiln-dried, stud quality), reduces the axial capacity by 37%.

The proposed preliminary design for the eave edge fastener is depicted in Figures 7-14 through 7-19. The secondary element attached to the eave edge stiffener is referred to as a foot in Figure 7-14.

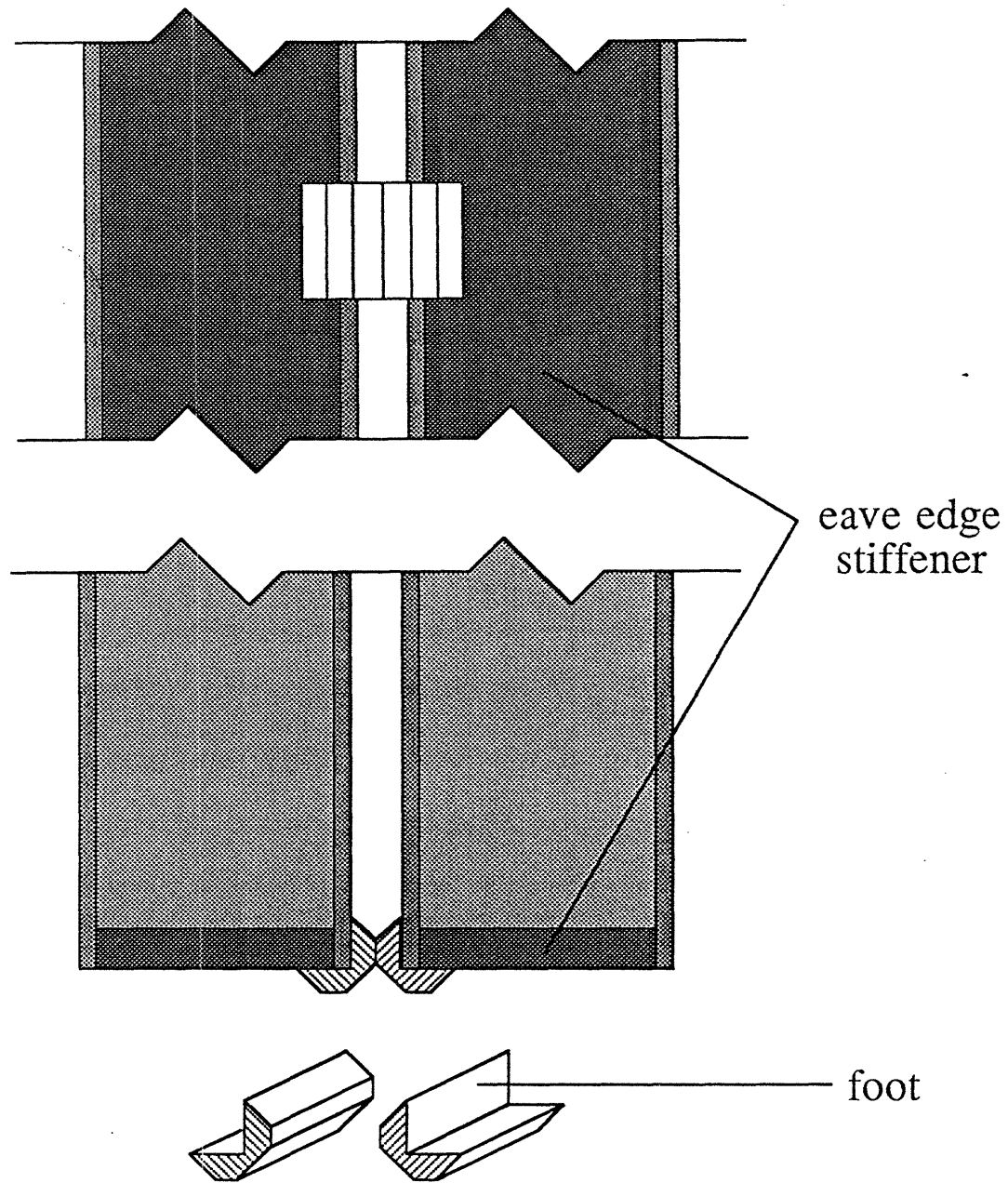

Figure 7-14: Hinge Pair with Eave Edge Fastener

Ideally, the eave edge fastener should have the ability to adjust to any roof slope,

thus limiting the number of parts in inventory. All eave accessories except the foot have this feature. The impact on the roof accessory inventory, however, is not appreciable. Since eave edge fasteners are attached in the factory, the inventory stock pile is limited to the panel manufacture site. The prismatic geometry of the foot, fabricated by extrusion or linear milling, is straight forward to produce and relatively compact to store.

The geometry and proportions of the foot are controlled by various factors (refer to Figure 7-14). The foot should provide a panel spacing which is equal to the spacing at the ridge edge fastener, since it is desirable to transport the paired panel units in a horizontal plane. Furthermore, the width and depth of the foot is determined by the panelized wall system in which it is to be inserted. The length of the foot in the longitudinal direction is controlled by the bearing area of one face needed to carry the the compressional load resulting from a floor tied system divided by the face thickness. Additionally, the longitudinal length is determined by the bearing strength of the foot material in transferring eave download and wind uplift.

7.4.3.1 Panelized Longitudinal Wall System

The foot is inserted into the routed edge of a panelized wall system (see Figure 7-15). Blocking is provided inside the routed edge to serve as a positional stop and load spreader for the foot, and to tie the two wall panel faces together. Recall that the edge of the foot is beveled to mate with the opposite foot of the hinged panel unit. This chamfered edge aids in the alignment and fitting of the foot into the routed edge of the panelized wall system. The other exposed edge of the foot is chamfered for the same purpose. The panelized wall system is assumed to be built such that tolerance errors are negligible (± 0.01). Nails are driven through the wall panel faces into the foot to resist longitudinal shear and wind uplift.

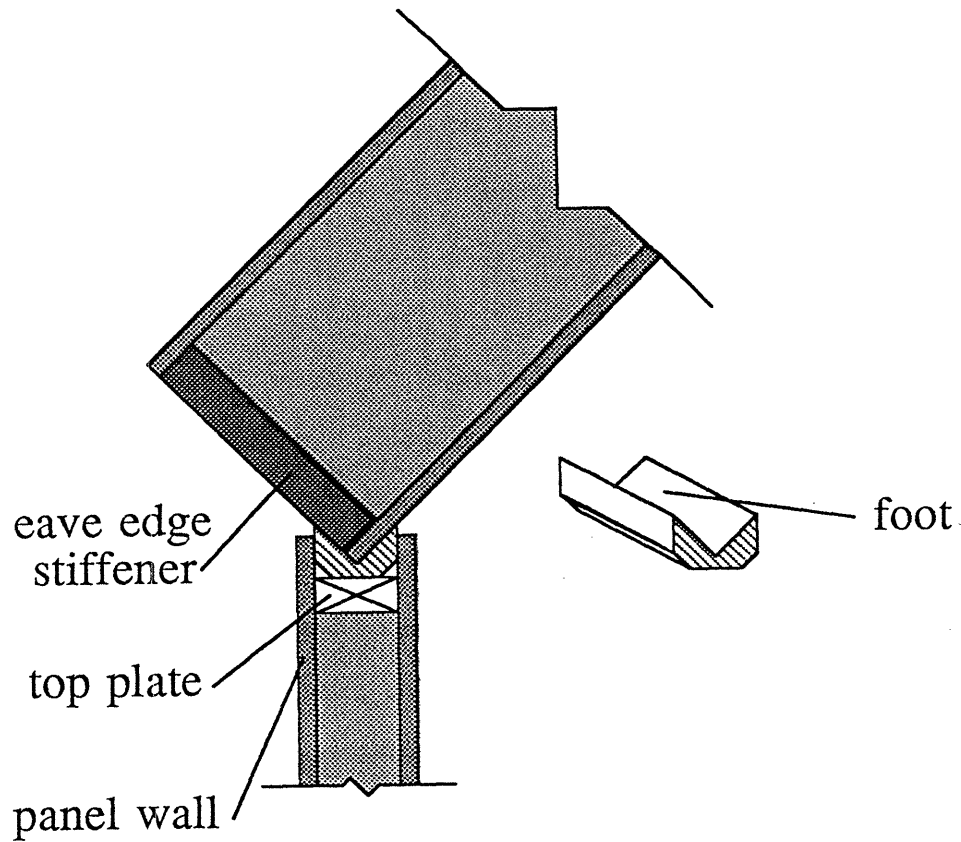

Figure 7-15: Panelized Longitudinal Wall Eave Connection

7.4.3.2 Wood Frame Longitudinal Wall System

The foot is set on top of the top plate of a wood frame wall (see Figure 7-16). The chamfered edges of the foot reduce the eccentricity of the axial load and end moment on the 2x4 wall system. The variation in the top plate elevation is corrected by the use of shim stock at the area of contact of the foot with the top plate. This height adjustment is performed before the deployment of the panels since the task is easier at this stage and top plate height variation may interfere with panel to panel alignment. A taut string running from gable line to gable line along the eave serves as an alignment aid in shimming. A light

gage metal nailing plate connector is nailed to the foot and the top plate. The standard load case (Chapter 6) with a pitch of 12/12 and an eave to eave width of 36 feet represents the maximum wind uplift that is likely to be encountered. For a four foot panel element width the maximum wind uplift is 818 lbs. per eave edge fastener. The allowable lateral load for a 8d common nail driven in species group IV is 51 lbs. [U.B.C. Standards, 88]. A 20 gage galvanized steel nailing plate connector measuring 3-1/8 inches by 9 inches provides 41 nail holes [Sweet's Catalog File, 88], of which 32 are required. Ideally, the eave edge fastener will be located over the stud, which will allow the nailing plate connector to be nailed into the stud to better resist wind uplift. The variation in the horizontal projected distance of the top plate from the reference ridge line is corrected by forcing a flexible wall system laterally in or out. If bracing or a corner detail restrains lateral re-alignment of the longitudinal wall, there are two proposed solutions: pack out the foot or the top plate to create a flush surface (see Figure (eavepack)), or insert a lag bolt from a hole drilled from the underside of the top plate into the foot and eave edge fastener (see Figure (eavelag)). Both the nailing plate connector and the lag screw resist wind uplift and longitudinal shear.

7.4.3.3 Tied Floor System Accessory

The foot is set on top of and connected to the floor unit to resist lateral roof thrust as shown in Figure 7-19. A secondary attachment accessory, referred to as a floor tie, is formed from a rectangular plate of light gage steel into which fastening holes are pre-punched. The floor tie is fastened into the floor unit before the roof panels are deployed. At the time of fastening, any variation in elevation and horizontal projected distance from the reference ridge line is corrected for using shims. Elevations are corrected by shimming under the floor units. If horizontal alignment is a problem, shims may be used to pack out the surfaces approximately flush. The floor tie can be bent to small angles if the surfaces are nearly flush.

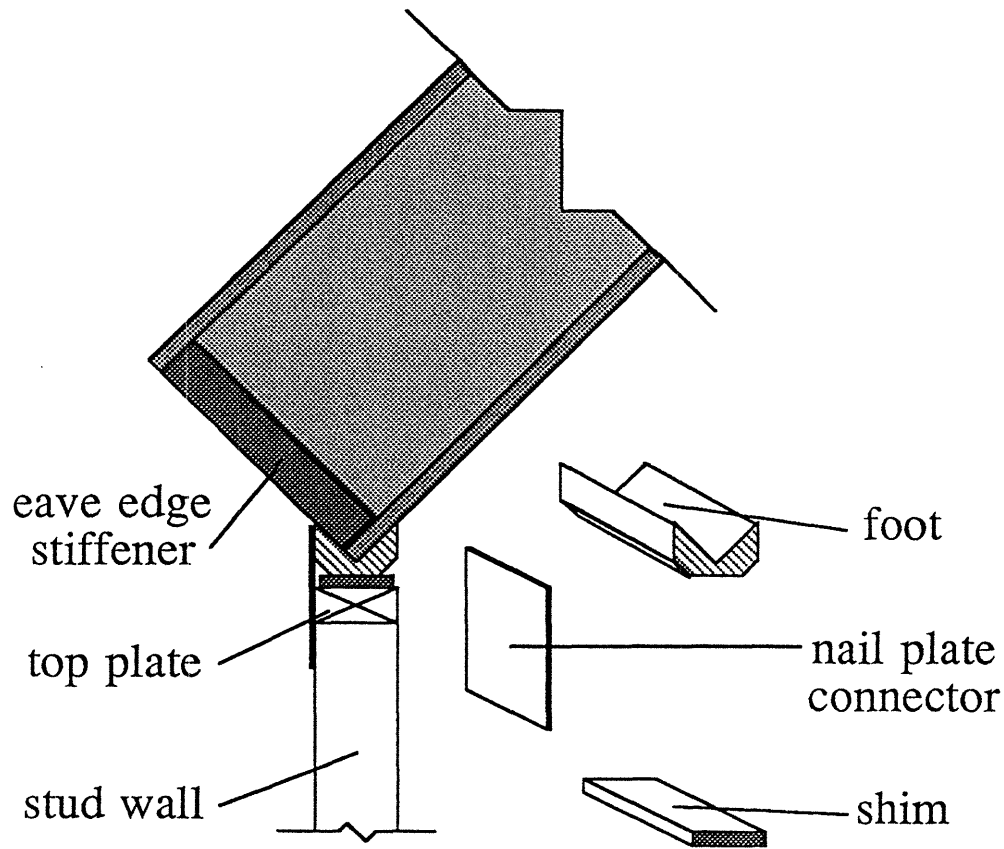

Figure 7-16: Wood Frame Longitudinal Wall Eave Connection

The floor tie is of double thickness in the region of the connection to the foot. The floor tie serves a double duty of resisting the wind uplift and longitudinal shear forces, and the lateral thrust component of in-plane roof panel forces. The outward thrust is equal to the in-plane fold line forces multiplied by the $\cos(\alpha)$, which can become large for low pitched roofs. The force is transferred into the foot by breaking the edge of the floor tie over the edge of the foot.

A negative moment is induced on the panel element due to floor tie eccentricity. The resulting moment is a maximum at the eave connection and decreases linearly to zero

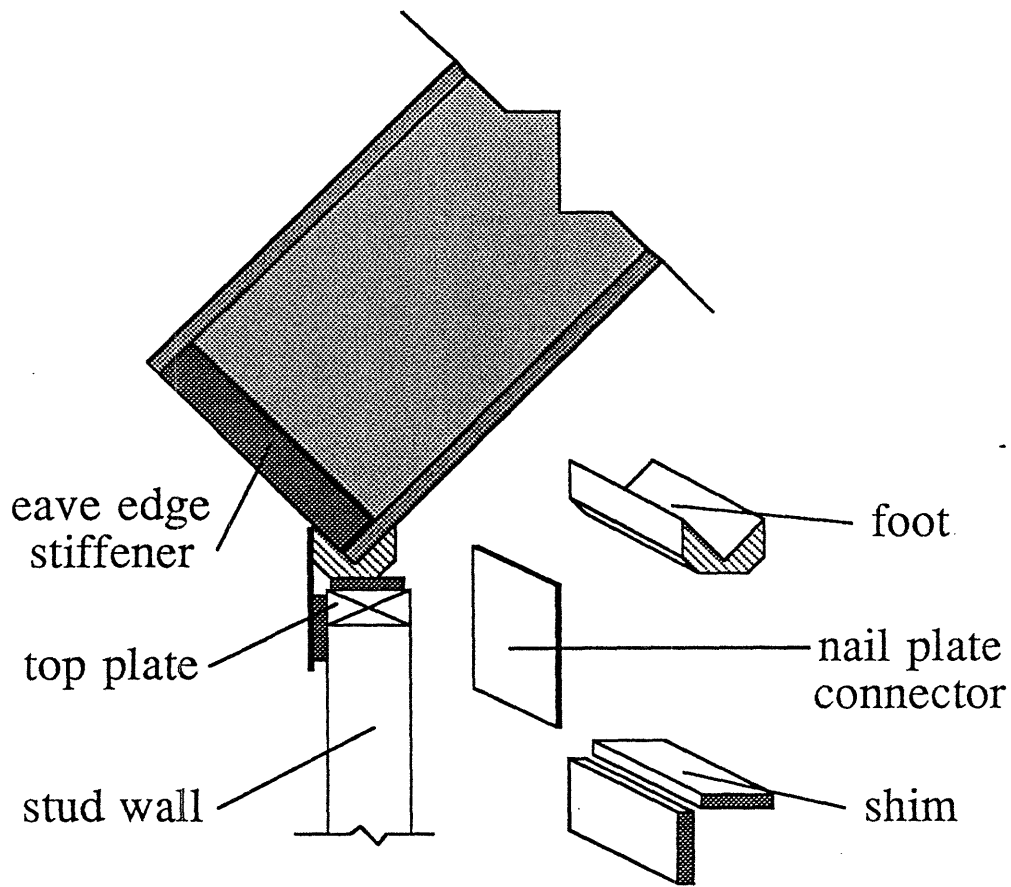

Figure 7-17: Mis-aligned Wood Frame Longitudinal Wall Eave Connection

at the ridge connection. The eccentricity at the floor tie is slightly less than the ridge edge fastener eccentricity. The moment magnitude due to the ridge edge fastener eccentricity was calculated in Section 7.3.2.3, where the moment decreases linearly to zero at the eave line. Superimposing these two negative moments results in an approximately uniform negative moment over the panel element. The opposite sign of live (snow) and dead moments diminish the effects of these fastener eccentricities. Outward wind suction on the panel elements, however, generates moments of the same sign, and a check regarding stresses and deflections must be performed for this loading condition.

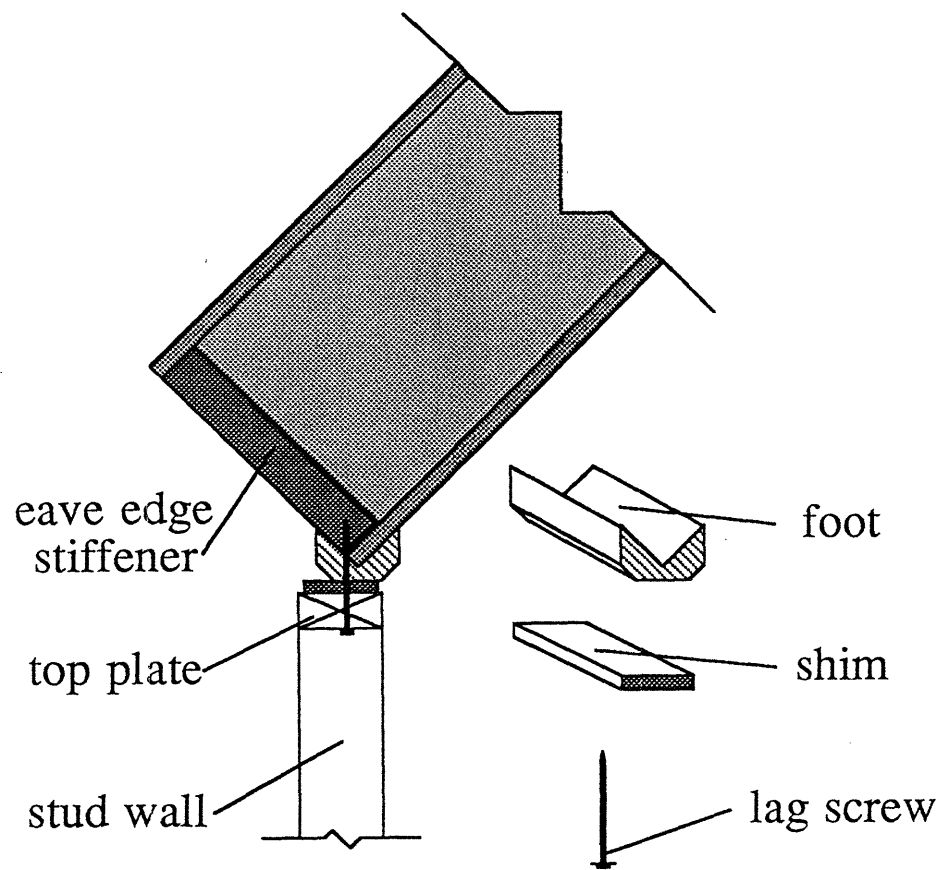

Figure 7-18: Mis-aligned Wood Frame Longitudinal Wall Eave Connection

7.4.3.4 Tension Cables

Tension cables provide a positive stop to eave distance separation and indicate when the correct pitch for the hinged panel unit has been achieved (see Figure 7-20). Tension cables also resist lateral thrust of the folded plate until all connections are made to the edge supports. In the folded plate the tension cables may be left permanently in place and fire proofing added to provide redundancy in the structure.

Only one tension cable need be attached to each hinged panel unit. This tension cable should be located near the edge of the panel to panel connection which is opposite

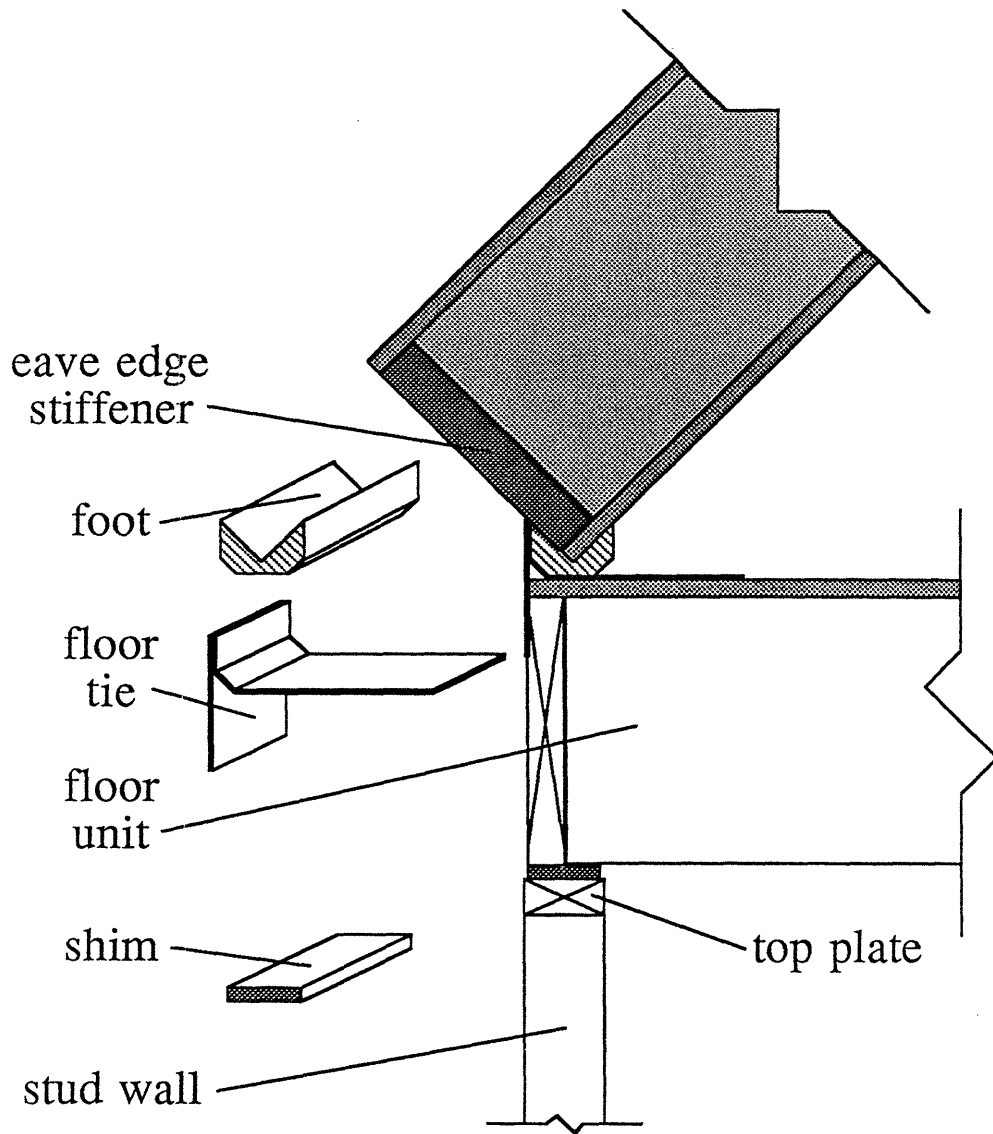

Figure 7-19: Tied Floor System Eave Connection.

the panel to panel connection to be aligned and joined. The addition of a tension cable near the panel to panel edge to be aligned would be redundant with the tension cable of the neighboring panel element. Moreover, tension cables provide a positive stop to eave distance separation and fix the roof slope angle, α . The eave to eave distance determined

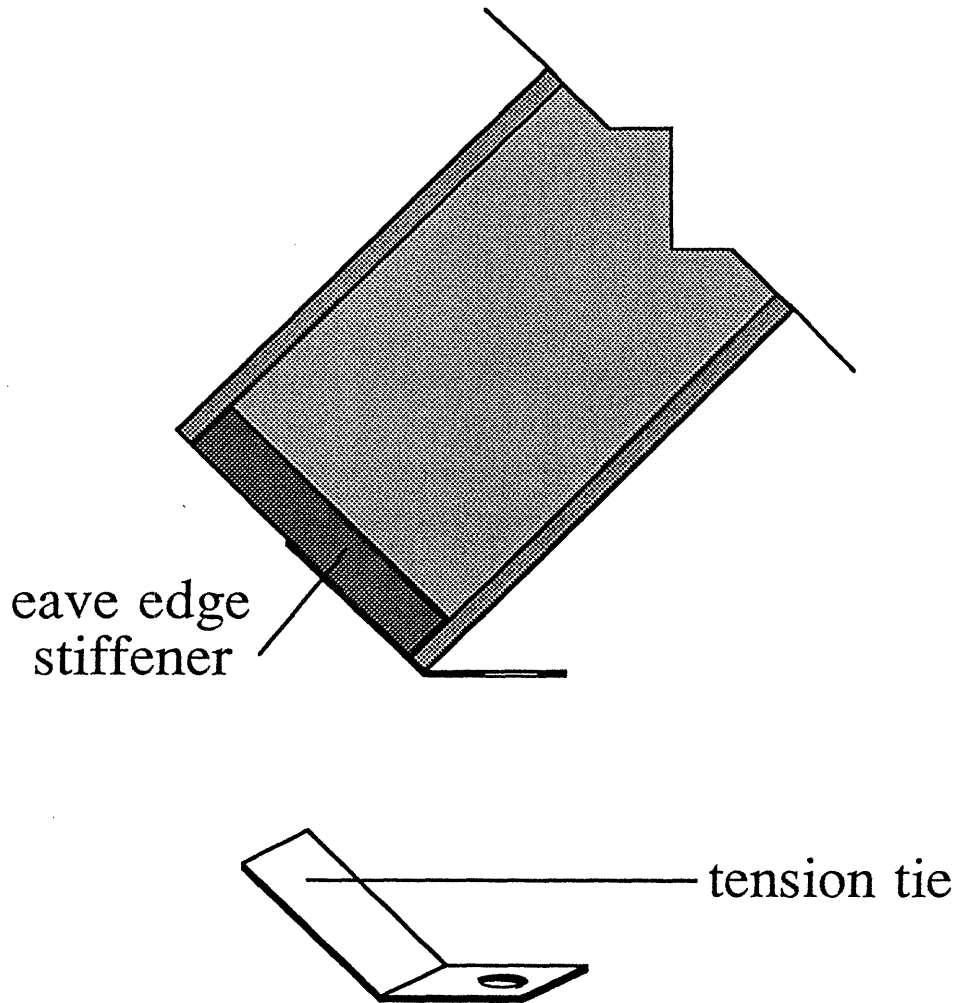

Figure 7-20: Tension Tie for Cables

by the tension cable of the hinged panel unit being deployed might not correspond to the exact eave to eave distance of the hinged panel unit which is already set on the roof, due to installment errors and cable stretch. An inserted panel to panel joint would present considerable problems with respect to redundant tension cables. Panel to panel joint types are discussed in Section 7.6. Adjustment in the tension cable length would have to be fine tuned before adjacent panels both have the same slope required for insertion. An additional crew member would be required since this adjustment would take place on the

interior of the roof or at the eave location. An overlaid or butted panel to panel connection would be less critical in terms of assembly, but would complicate the panel to panel connection by the possibility of the panel to panel connection not being flush.

7.4.3.5 Eave Edge Fastener Summary

In summary, eave edge fasteners:

1. localize connections made in the field.
2. provide discrete locations where height variation of the longitudinal wall is corrected.
3. provide fastening points for floor tie to the floor unit.
4. are compatible with stick built construction or panelized wall systems.
5. possess little eccentricity.
6. possess little moment rigidity.
7. provide positive seating for the panel element on the longitudinal wall.
8. allow for lateral mis-alignment of the longitudinal wall.

7.4.4 Insulation

There are multiple methods of insulating the eave line.

In the eave connection to a panelized wall, the routed region of the top edge provides a trough into which foam can be injected. The foam rises against the surface of the panel eave edge, seals against air infiltration, and is flexible to the thermal bowing of the eave edge stiffener. Alternatively, loose insulation or fiberglass batts could be stuffed into the void, a messy solution. The eave overhang might incorporate an insulating jacket into its construction.

In the stick built wall, a strip of closed cell polyethylene foam could fill the void between top plate and the panel eave edge. This highly compressible material was originally used in housing construction as a seam sealer between the sill and the uneven top surface of the foundation. The foam strip could be pre-attached in the factory to the

panel edge. The foam extends a measured distance beyond the eave edge fastener, and compresses once placed on top of the top plate. The foam would expand and contract to fill the gap created by the thermal or hygroscopic bowing of the eave edge stiffener.

7.5 Gable Connection

The gable line is subjected to the in-plane shear loads of roof diaphragm or folded plate action, as well as loads transverse to the panel element arising from wind forces on local areas of discontinuities, dead, live and seismic loads. The loads on the rake are as follows:

Loads at Rake (standard load case, Chapter 6)

Uplift (vertical)

pitch = 12/12 eave width = 36'	217 lb./ft.
pitch = 3/12 eave width = 36'	238 lb./ft.

In a folded plate, the gable endwalls resist significant-in plane loads. A 6/12 pitch roof results with a length of 40 feet results in a maximum in-plane shear load of 1916 lbs./ft. at the gable line. A comparison of roof diaphragm behavior of a floor tied or a ridge beam system to a folded plate system normalized about a 6/12 pitch and an eave to eave distance of 20 feet follows:

Normalized Roof Diaphragm and Folded Plate Loads with Respect to a 6/12 Pitch Folded Plate (standard load case, Chapter 6)

Pitch (x/12)	Roof Diaphragm	Folded Plate
3	0.093	2.10
4	0.095	1.58
5	0.115	1.24
6	0.137	1.00
7	0.159	0.831
8	0.181	0.706
9	0.223	0.613

10	0.248	0.559
11	0.272	0.554
12	0.296	0.554

An examination of the above table shows how the demands on the "plate" action of the roof for a folded plate compare to the roof diaphragm behavior of a ridge beam or floor tied system. Lower pitched roofs are more efficient at resisting roof diaphragm loads, while steeper pitched roofs are more efficient in folded plate action. At a pitch of 12/12, the roof diaphragm loads are 53% of the folded plate loads. Although the in-plane forces of the folded plate are roughly twice that of the roof diaphragm, the need for a ridge beam, or a floor system has been removed in the folded plate design. A comprehensive economic comparison of the folded plate to the ridge beam and floor tied system must weigh increased in-plane joint demands against ridge beam and floor systems costs.

7.5.1 Trussed Gable Endwall

The trussed gable endwall resist the lateral thrust of the folded plate or diaphragm behavior by a tension tie between opposite corner posts (see Figure 7-21). The trussed configuration transfers the download resulting from the folded plate or diaphragm action to the corner posts. This download is equal to the tributary ridge line load typically carried by the ridge beam end support in the folded plate. The transverse endwall must still be designed to transfer the wind and seismic roof diaphragm forces to the ground plane by preventing racking in the corner posts.

7.5.2 Gable Edge Stiffener

The gable edge stiffener has several functions and design criteria. The gable edge stiffener is made of a material with a coefficient of thermal expansion near that of the face material. Otherwise, differential strain between the two components would stress the face and edge stiffener bond. Aside from providing a material which can be fastened to, the

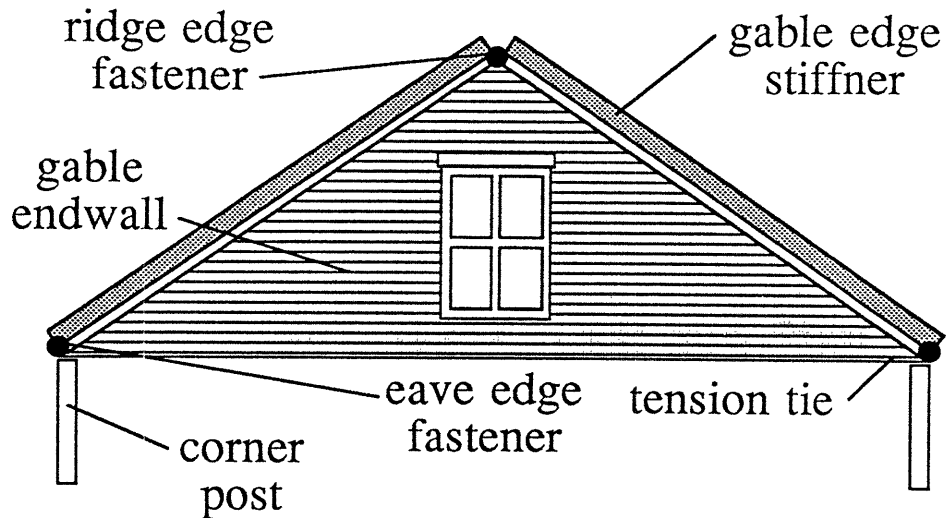

Figure 7-21: Trussed Gable Endwall

gable edge stiffener collects the in-plane loads from the panel faces, and ties the two panel faces together. This duty is critical at the gable line where in-plane shear forces are at a maximum. The means of fastening the gable edge stiffener to the gable endwall determines the forces that the stiffener will experience.

The edge stiffener performs several duties if allowed to bow or deflect as a beam. The gable edge stiffener reinforces the one-way slab action of the panel element in resisting large wind loads due to local roof discontinuities at the rake. These forces, which are normal to the roof panel, are resisted by the ridge and eave fasteners. Due to the increases in loads at the rake discontinuity, a double pair of standard ridge and eave fasteners might be located nearest the gable line. Additionally, the gable edge stiffener resist the thermal and hygroscopic bowing of the panel element. If a tension tie running from gable and eave line intersections resists the lateral thrusts, the edge stiffener behaves like a column pinned at either end.

7.5.2.1 Gable Edge Stiffener Summary

In summary, gable edge stiffeners:

1. are made of a material with a coefficient of thermal expansion near that of the face material.
2. provide a fastening material.
3. act as a shear diaphragm strut collector by tying the opposite faces of the panel together.
4. are designed as a beam to reinforce the one-way slab action of the panel element in resisting wind loads due to local roof discontinuities at the rake, if allowed to deflect.
5. are designed as a beam to resist thermal bowing, if allowed to deflect.
6. are designed as a column to carry the in-plane shear loads which are carried out to the gable line, and resolved at the tension tie.

7.5.3 Gable Edge Fastener

If the gable edge stiffener is fastened continuously and rigidly along its length to a gable endwall, the edge stiffener does not undergo column action as a compression member in a truss. The in-plane shear loads are distributed evenly along the length of the gable endwall edge. Since the gable edge stiffener is not allowed to deflect as a beam, the thermal and hygroscopic edge reactions, the normal live, dead, wind and seismic forces are transferred into the gable endwall by the the gable edge fasteners. The gable endwall, and not the gable edge stiffener, resists the the edge reaction of thermal and hygroscopic bowing, since the gable edge stiffener is never allowed to deflect. As discovered in the study of rectangular plates with four edges simply supported, the corner edge reactions can become very large, pointing to the impracticality of this scheme.

In the case of a trussed gable endwall, a solid backing is required for infill. The infill, however, should not come into conflict with the thermal and hygroscopic bowing of the gable edge stiffener. Resistance to panel bowing would result in significant reaction forces being exerted on the ridge and eave fasteners (refer to Figure 7-22). The desired

connection to the gable endwall allows for the sliding of the gable endwall structure with regard to the edge stiffener, and still resists the wind forces normal to the gable endwall, while providing a weather tight seal.

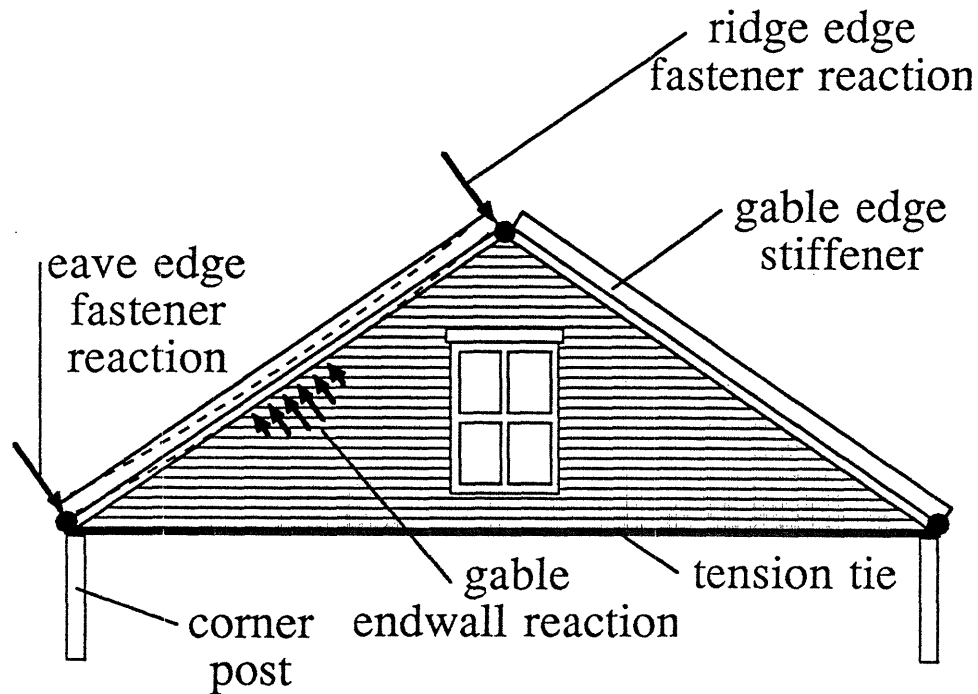

Figure 7-22: Thermal and Hygroscopic Bowing of the Gable Edge Stiffener

The variations in the proposed gable endwall detail are shown in Figure 7-23 and 7-24. The spacers are rigidly attached to the gable edge stiffener in the factory. The fascia is nailed in the field to the the spacers after the gable endwall has been placed. As the gable edge stiffener deflects and bows, it slides in relation to the gable endwall. Molding, attached to the interior of panel face, aesthetically covers the expansion joint. The detail provides an ornamental fascia board. If a rake overhang is desired, a secondary component, similar to the eave overhang, would provide design flexibility, and insulation to the gable edge stiffener.

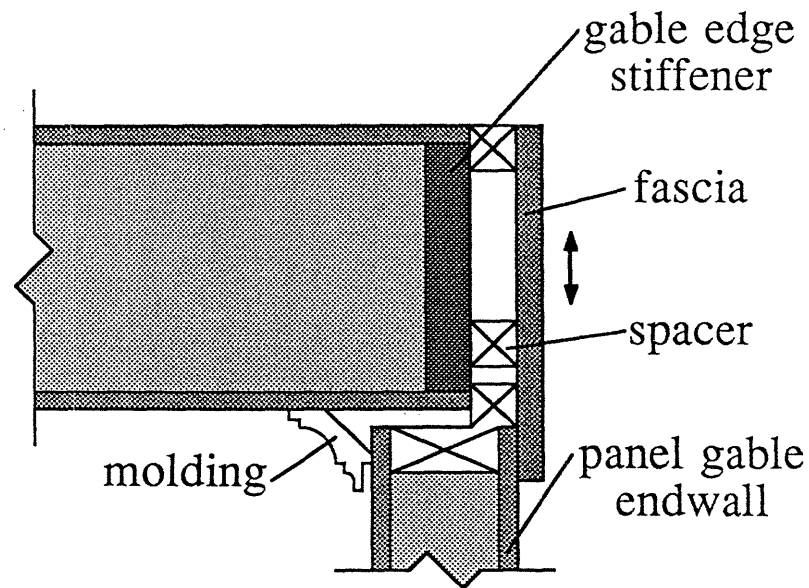

Figure 7-23: Detail of Panel Gable Endwall as Viewed Along the Gable Line

7.6 Panel to Panel Connection

The ability of sandwich panel faces to resist racking loads establishes the transfer of shear across the panel to panel joint as a problem which is universal to all sandwich panel construction. The constructibility of this connection in the field is of crucial importance to the viability of a building system. Panel to panel shear is present in roof diaphragm action, but becomes the critical design parameter in folded plate construction. The panel to panel shear can be calculated from the loads given in Section 7.5. The panel to panel in-plane shears for the different load cases vary linearly from a maximum at the gable line to one quarter this value at the midspan. Therefore the maximum in-plane panel to panel load might be considered 1916 lbs./ft. as a result of a 6/12 pitch roof and a length of 40 feet with standard load case.

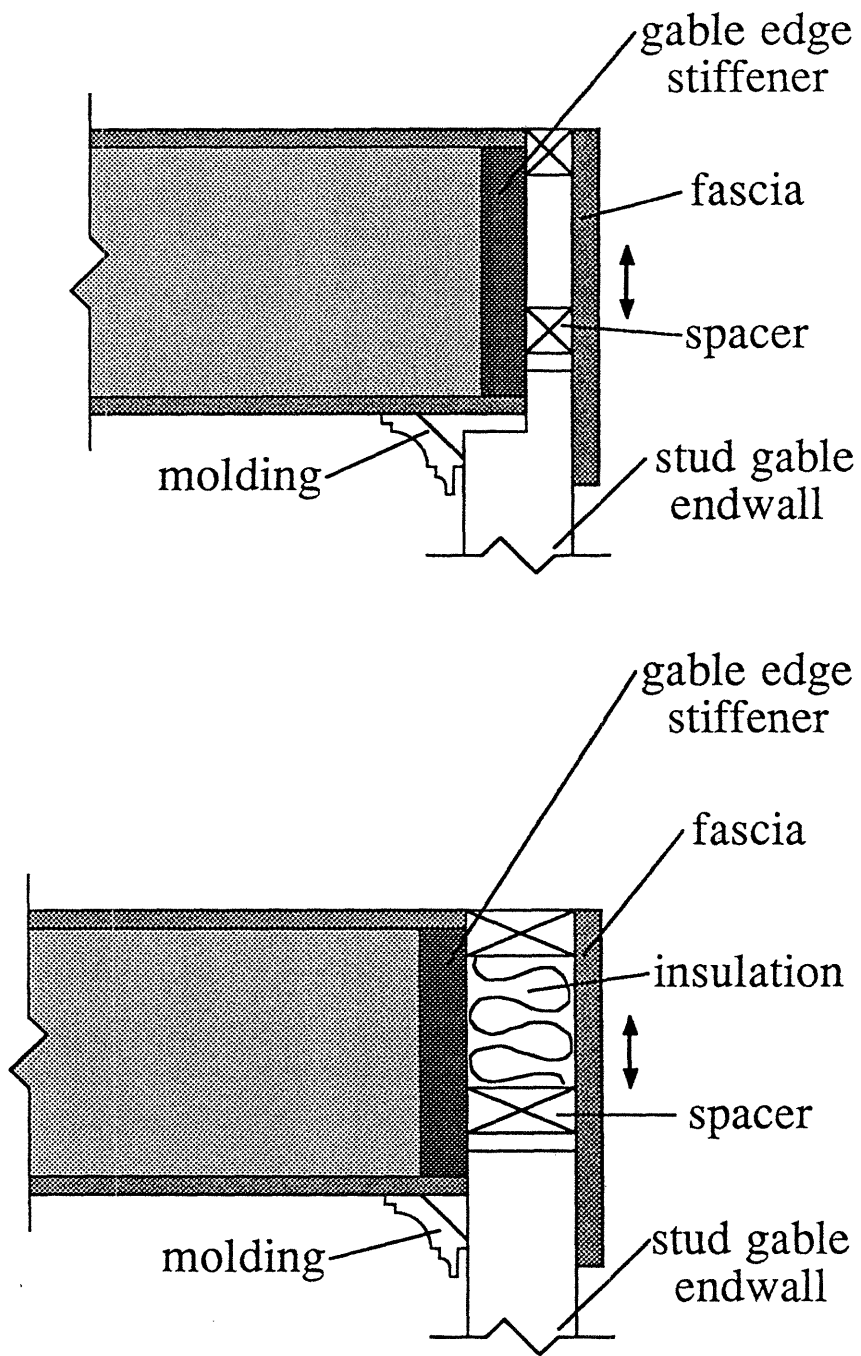

Figure 7-24: Detail of Stud Gable Endwall as Viewed Along the Gable Line

In sandwich panel to panel joint design, the critical connection is between adjacent

panel faces. The core material has minimal impact on the joint behavior, but does concern the fabrication process. The face material may be divided into four generic groups, according to the manufacturing and material processing:

1. Sheet facing (plywood, waferboard, oriented strand board, etc.).
2. Malleable facing (steel, aluminum, etc.).
3. Molded facing (includes organic/inorganic, structural fiberglass, etc.)
4. Extruded facing (includes polymers, structural fiberglass, cementitious materials etc.)

Several preliminary panel to panel joint geometries for the above face material categories are described. Panel to panel connections can be divided into three types: inserted, overlaid, or butted (refer to Figure 7-25).

Utilizing a crane in the construction assembly suggest that the overlaid and butted panel to panel connection may be the more forgiving methods of roof panel assembly. When compared to overlaying and butting, panel to panel insertion requires alignment along an additional axis. Inserted panel to panel joints require that the exact pitch of the adjacent panel be matched before panels can be joined. Variations in longitudinal wall height would interfere with this alignment. Furthermore, varying wind forces can complicate the deployment of large panels by crane.

An important issue in panel to panel connections is symmetry. If panel to panel connections are of a female and male pairing, as with the insertion joint, differing fabrication techniques are required for either panel edge. With the overlaid joint the panel connections may be identical, but rotated 180°. These anti-symmetric geometries create a left and a right panel, where the orientation of the panel must always be considered before placement. This differentiation in placement complicates the production of the panel elements, and can be a major handicap on the job site, especially if workmen are not adept at spatially visualizing the panels present and final positions.

a) inserted

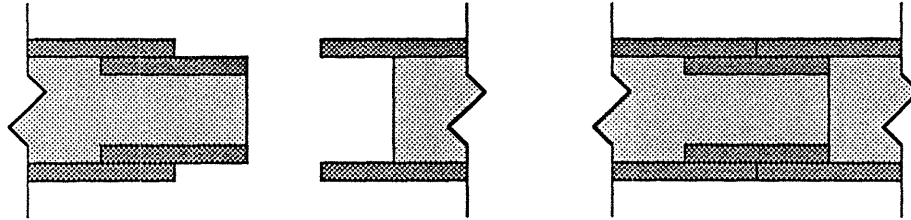

b) overlaid

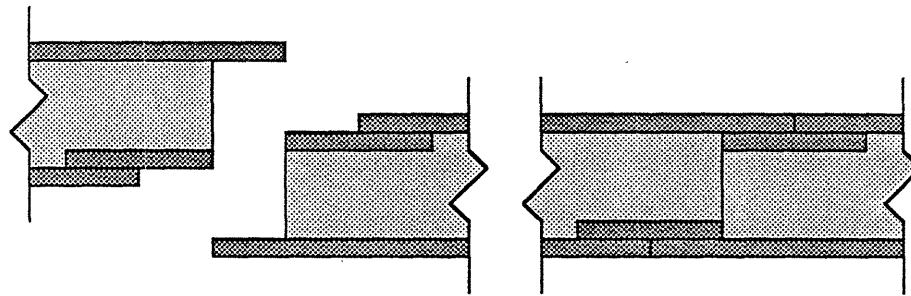

c) butted

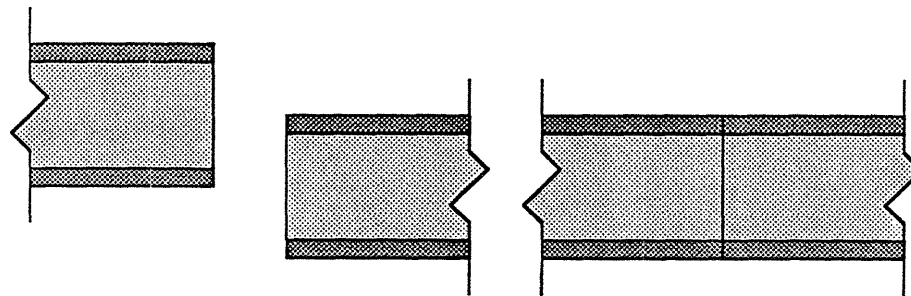

Figure 7-25: Panel to Panel Geometry

If exposed to thermal and hygroscopic gradients, a panel to panel joint should not possess great flexural rigidity. Moment rigid panel to panel connections create a

monolithic slab over the entire roof panel. From the study of thermal and hygroscopic behavior of two-way slabs, large edge reactions on the ridge, eave and gable line connections result from the panel behaving as a rectangular plate simply supported along four sides.

Expansion and contraction should be permitted at each panel to panel connection. If expansion joints are not provided at the panel to panel connections, buckling of the panel elements along their widths might occur. The edge stiffeners along the eave and ridge may not be subjected to the same thermal or hygroscopic effects, because of their thermal mass. The linear dimensional stability of the edge stiffeners can be depended upon to control the overall behavior of the roof panel in the longitudinal direction. The tension splices restrain the edge stiffeners, so that if spacing between panel to panel edges is not provided for, the panels may reach buckling loads. This could result in failure of the roof covering or the face materials. Panel edges are properly spaced at every panel to panel joint to de-couple their influence on dimensional stability of the roof panel in the longitudinal direction.

The fragility of the panel to panel connection is also a consideration. Inserted and overlaid joints have panel faces which extend beyond the support of the panel core. These panel faces are subject to edge damage, or fracture depending on the material properties of the faces. Deploying the panels by crane may subject these edges to large, accidental impact loads.

There are many possible variations in the joint geometry within the three major panel to panel types of overlaid, butted and inserted which are partially dependent on the face materials. Variations in the joint geometry occur due to differences in the processing and workability of the four face material divisions. The research team has, at the time of this thesis writing, not selected the face material. Therefore, the panel to panel joint will be developed independent of the face material.

The geometric restraints on the panel to panel connection are multifaceted. A gap should be provided between the panel to panel connections to provide for face expansion along the panel's width. Additionally, there is a problem of differential thermal movement along the length of the panel to panel connection line. This differential strain might occur if one panel element is exposed to the sun, and the adjacent panel element is in the shade. The differential linear contraction and expansion along the joint line will lead to over stressing in the outer region of the panel to panel connection which could result in joint fatigue, or ultimate failure. This difference in thermal gradients for adjacent panels would induce bowing in the panel element exposed to the sun, while the adjacent panel would be unaffected, resulting in shears across the panel to panel connection. Movement perpendicular to the panel to panel connection line and normal to the roof must be prevented. Panel faces must remain flush across the joint for appearances as well as preventing fatigue in the roof coverings.

The inserted panel to panel connections present difficulties in joining hinged panel units, because they require alignment along an additional axis. Inserted and overlaid panel to panel connections are not symmetric and are fragile. For these reasons the butted panel to panel connection is selected as the concept to be developed.

7.6.1 Panel Web Concept

The panel to panel connection concept is depicted in Figure 7-26. Opposite faces of the panel are connected by a thermally non-conductive, high strength material, referred to as a web. The joining together of the opposite panel faces distributes in-plane shears between faces, transfers in-plane loads between panels, resist shear forces normal to the plane of the panel element, and protects the core from damage.

The web is produced of a hypothetical material, referred to as material X. The material has the flexibility of a heavy duck cloth before it is processed to create its

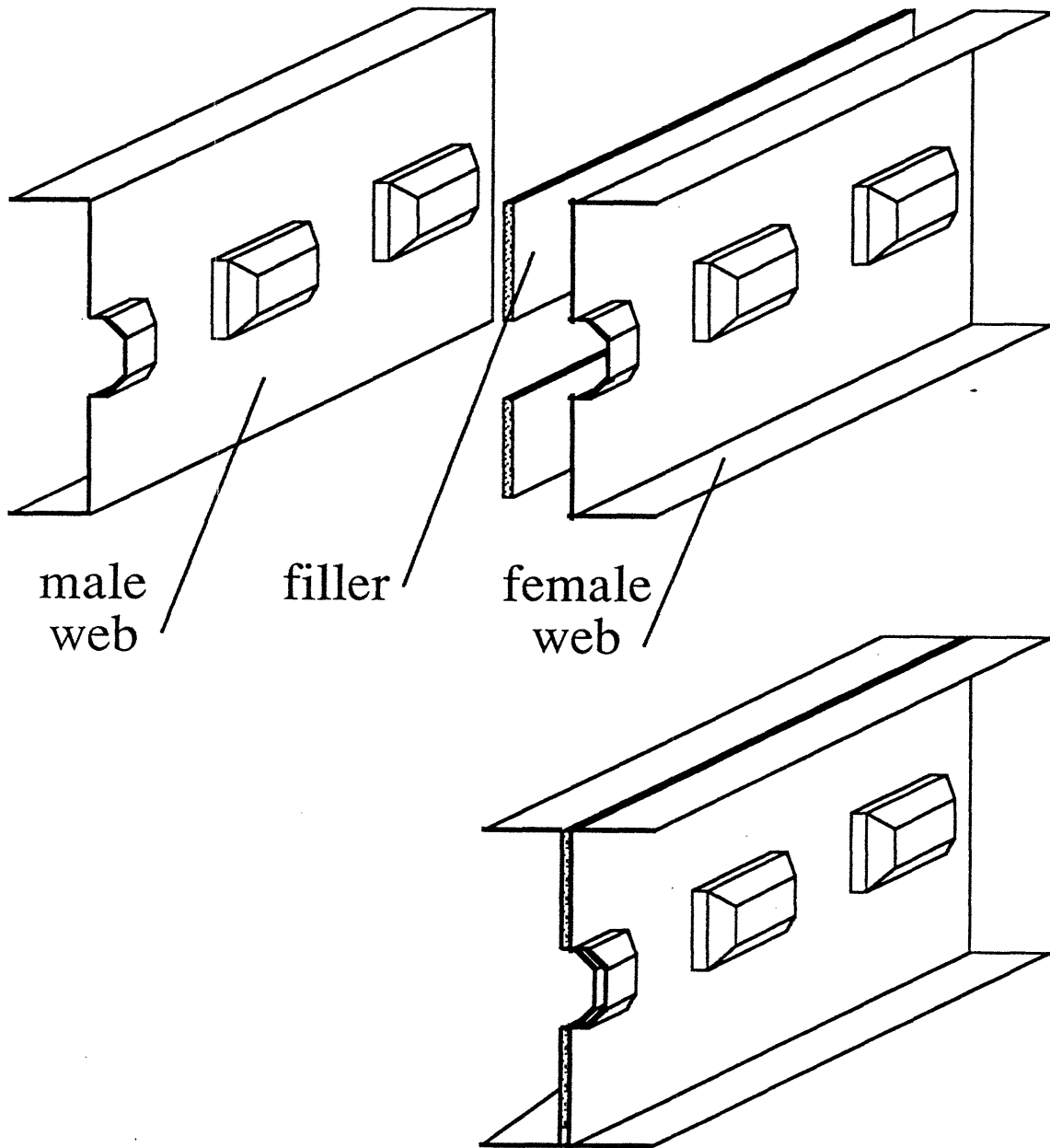

Figure 7-26: Panel to Panel Web Accessories

stiffness and high strength. Material X is a hypothetical material which has the strength of aluminum at a quarter of aluminum's price. The modulus of material X is approximately

that of a good plywood, and is assumed to be very moldable. Material X is assumed to possess very good fire performance, and have a thermal conductivity comparable with a dense wood.

Material X is well suited for use as a panel web due to the material's high strength, low modulus, low cost, low thermal conductivity, and good moldability. The material is formed into a male and female accessories which are attached in an identical fashion to the panel faces and core. The panel edge treatment is the same for both male and female webs. The web is molded with edges for adhering to the panel faces. Rectangular boxes project from the mid-depth of the panel web. These male and female boxes insert into one another, to transfer shear across the panel to panel connection. The rectangular boxes are chamfered on the exposed edges to allow for ease of alignment and insertion in the field. An expansion gap between the panels is provided between webs to allow for expansion and contraction of the panel faces in the transverse direction. The rectangular boxes project beyond and perpendicular to the flat surface of the web to allow the rectangular projections to slide into one another.

A thin layer of compressible, foamed elastomeric, non-permeable material, referred to as filler in Figure 7-26, seals the gap between adjacent panel webs. The filler acts as a compressible non-permeable seal. It allows the gap between adjacent panels to expand and collapse, while guarding against air infiltration and a subsequent vapor control problems. The filler is adhered to the adjoining panel edge when the panel to panel connection is made on the site. Glue, applied with a roller to the web, is the only field work that is required. The panels are simply butted together. No mechanical fastening or adhering is required to develop joint strength.

7.6.1.1 Preliminary Web Design

The suitability of material X for the panel web application can be verified by a few simple calculations. Simplifying assumptions are made for these "back of an envelope" calculations. Since the panel web is adhered to the panel core to transfer shears normal to the panel faces across the panel to panel connection, the panel core is assumed to prevent web crippling and compressive buckling of the panel web. The projecting boxes must be designed to bear on one another to transfer in-plane loads between adjacent panels. The projecting boxes are assumed to be capable of bearing on their mated box to the loads required. Should this not be the case, the projecting boxes could be reinforced by a filler added inside the projecting box in the case of the male web, and filleted with a filler material outside of the projecting box volume in the case of the female web. A more sophisticated analysis, such as the finite element method, is strongly recommended for the study of the transfer of transverse shears (normal to the roof surface) across the panel to panel connection which result from one panel element's exposure to a thermal gradient, while the adjacent panel is not exposed (in the shade).

If one panel is exposed to a thermal gradient, and the adjacent panel is not, differential movement at the panel element ends occur. The panel webs must be able strain to absorb this differential relative motion with the stresses remaining below their allowable level. If the face material is assumed to have a thermal coefficient of expansion equal to that of steel (an upper limit), the length of the panel element is 25 feet, and one panel is exposed to a thermal gradient of 100 °F while the adjacent panel is not exposed, the differential movement at the panel end, measured at the panel mid-depth of the panel is 0.04875 inches. If both webs of the adjoining panels are identical in design, the differential movement at the midspan of either web is one half this value, or 0.02438 inches. The projecting boxes of the male and female webs are conservatively assumed to be a distance of four inches from the panel faces. The resulting shear strain in the panel

web is 0.2438 inches divided by four inches, or 0.00609375. Assuming a shear modulus of 700,000 p.s.i. for Material X, the shear stress due to this differential movement between adjacent panels is 4220 p.s.i. A factor of safety of 3.0 yields a design load of 12,660 p.s.i., which is well below the probable ultimate shear strength of the panel web. A maximum in-plane panel to panel shear of 1916 lb./ft. with a factor of safety of 3.0, results in a panel to panel shear of 5748 lb./ft. This shear is distributed equally between the two attaching panel faces. The resulting shear is 240 lb./in. in the panel web section. A panel web thickness of 0.05 results in a shear stress of 4800 p.s.i. from in-plane panel to panel loads alone. If the shear stress arising from the differential thermal gradient is added to this value, the total shear stress in the panel web would be 17,460, which is well below the probable ultimate shear stress of material X. It may be noted that this superimposed load is highly improbable. The maximum in-plane loads infers a snow load, which would insulate the roof panel from a differential thermal gradient between adjoining panels.

7.6.1.2 Utilities

Placement of utilities within the thickness of the roof elements can be provided for in the panel to panel connection. Ceiling lighting requires electrical conduit to be installed within the roof panel depth. Providing a channel at every panel width of four or eight feet, would provide enough flexibility to meet most designers needs. This utility channel is integrated into the panel to panel connection at fabrication. The utility channel is a groove which is integrated into the panel web (refer to Figure 7-27). The filler is indented from being flush with the interior panel face. Electrical conduit can be fed and adhered in this utility groove.

7.6.1.3 Frostlines and Thermal Bridge

Builders point out that on a cold winter day frost lines form on top of panelized foam-core roof panels where 2x lumber is used as a spline to join panels together. This indicates that there is some short circuiting of the thermal resistance of the panel. This

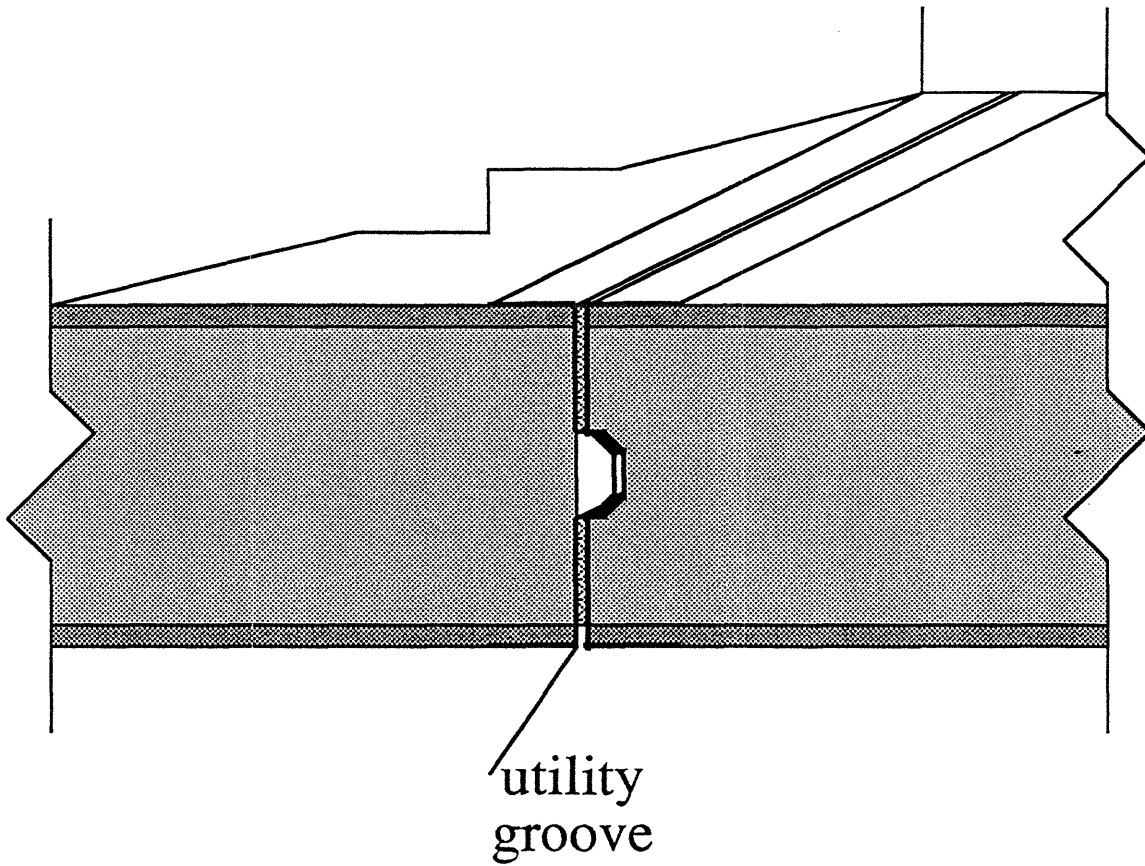

Figure 7-27: Panel to Panel Connection

problem must be examined for the web which connects panel faces. Given a highly thermally conductive web, this could be a problematic area which needs to be studied in further depth. Is the problem any different from batt filled un-vented conventional roofs? Will this phenomenon effect the long term durability of the roof panel system? The thermal analysis of the joint could be studied with the aid of finite element analysis, or thermal testing.

Chapter 8

Construction Sequence

8.1 Introduction

Five methods of building a single bay, simple span, sandwich panel roof are proposed. A simplified outline of the construction sequences follows:

1. Rectangular sandwich panel elements are produced as net-shaped parts in the factory with exterior roofing membrane and interior finish applied.
2. Panel elements are hinged at the fold line in pairs (interior faces are adjacent and protected from damage during handling).
3. Hinged panel units are transported to the site.
4. Three folded plate erection sequences are considered:

a. Method 1:

- i. Tension cable is pre-attached from eave line to eave line to create an "A" shaped, trussed hinged panel unit.
- ii. Deployed by crane, the lateral thrust of the hinged panel unit is resisted by the tension cable.
- iii. Hinged panel units are butted and joined to create, in situ, a folded plate panel.
- iv. Panels are connected to edge supports.
- v. Tension cables are fire-proofed if exposed.

b. Method 2:

- i. A camber ridge beam, designed to carry the dead load of the panel elements, is installed.
- ii. Deployed by crane, the hinged panel units are supported by the ridge beam which acts as a centering.
- iii. Hinged panel units are butted and joined to create, in situ, a folded plate
- iv. Panels are connected to edge supports.

c. Method 3:

- i. Tension cable is pre-attached from eave line to eave line to create an "A" shaped, trussed hinged panel unit.

- ii. Deployed by crane, the lateral thrust of the hinged panel unit is resisted by the tension cable.
- iii. Hinged panel units are butted and joined to create, in situ, a folded plate panel.
- iv. Panels are connected to edge supports.
- v. Compression struts are placed in the redundant ridge edge fastener.
- vi. Tension cables are removed.

One ridge beam erection sequence is considered:

a. *Method 4:*

- i. Ridge beam (either a laminated veneer lumber or a gluelam) is installed.
- ii. Deployed by crane, the hinged panel unit is supported and aligned on the ridge beam.
- iii. Hinged panel units are butted and joined to create, in situ, a roof diaphragm.
- iv. Panels are connected to edge supports.

And a tied floor system is considered:

a. *Method 5:*

- i. Floor system is deployed on top of the longitudinal wall
 - ii. Deployed by crane, the hinged panel unit is aligned on top of and attached to the floor system to resist lateral thrust.
 - iii. Hinged panel units are joined to create, in situ, a roof diaphragm.
 - iv. Panels are connected to gable supports.
5. Finally, the roof is weather sealed and the interior is finished along the joint seams.

8.2 Redundancy in Folded Plate

Redundancy typically found in traditional roofing systems is not present in the folded plate system. The failure of a single wood truss does not result in the sudden collapse of the total roof system. Wood trusses are constructed with a factor of safety of 2.5, and load re-distribution allows neighboring trusses to catch the load preventing a progressive failure. Similarly, the failure of a single rafter supported by a ridge beam does not result in total roof collapse. Whereas, in a folded plate, the failure of any one critical component results in the sudden collapse of the entire roof. The failure of a panel element, a tension splice in a longitudinal line member, or the deterioration of a panel to panel joint, gable line, or ridge line connection would result in catastrophic roof failure. These failures could arise from any number of effects: corrosion of fasteners, dry rot or brittle failure of the face material, core de-bonding, faulty workmanship, or combustion. The issue of fire safety in residential construction is gaining in importance. Collapse of the total roof system as a result of fire damage to one region poses an unacceptable threat to fire personnel and inhabitants under the roof structure. In a worst case scenario: a folded plate extends over the garage where a fire burns undetected; the entire roof suddenly collapses from the failure of a panel element in the region of the garage. The liability of a non-redundant, untested structure may possess too great a risk to all parties involved: panel producers, builders, developers, and home owners.

The lack of redundancy in folded plates can be addressed in a number of ways. Tension cables attached from eave line to eave line to deploy the folded plate might be left permanently in place (folded plate erection Method 1). The tension tie would be designed to carry the full load of the live and dead loads. This solution does have the drawback of aesthetic interference since the cables could be visually obstructive to a cathedral roof space. Fire insulation of the metal cables would be required to prevent failure due to exposure to high temperature. Alternatively, if a ridge beam is employed as a centering in

the deployment of the folded plate, the ridge beam could also function as a redundant structure in catching the weight of a failed folded plate (erection Method 2). Installation of a compression strut with redundant ridge edge fasteners would serve as a failsafe in case of folded plate failure (erection Method 3).

The indeterminacy of a redundant structures can be avoided. The redundant system to the folded plate must be designed to carry the full roof load. Failure of the folded plate would result in a load transfer to the redundant system. The dropping of the roof would alert the home owner of the structural failure of the folded plate. Otherwise, if the tension tie is stressed, the folded plate action may not be wholly engaged. After the folded plate has been constructed, the tension cables could be slackened, so that in case of the failure of the folded plate, the tension cables would catch the load, with an accompanied drop in the roof line. A folded plate constructed on the centering of a ridge beam, could be raised above the ridge beam by temporary blocking which would be removed after the folded plate structure is completed.

In certain cases a non-redundant folded plate may be deemed acceptable. Increasing safety factors reduces the risk of catastrophic failure. Tension cables used to deploy the folded plate could be removed after the folded plate is constructed. Alternatively, a collapsible centering jig in the building interior could support the hinged panel units until connections are made to create a folded plate.

8.2.1 Construction Assembly Sequencing

Panel assembly is sequenced to allow for the precise fitting and alignment of the roof building system independent of tolerances in the supporting structure.

In ridge beam systems, the ridge beam guarantees the proper alignment of the ridge line with the reference ridge line. Proper seating of the ridge fasteners with the center line of the ridge beam allows panels to be joined smoothly together in succession.

The floor tied system requires that the floor units be shimmed to a consistent vertical projected distance from the ridge reference line. Proper layout of eave ridge fasteners along lines which are parallel to and the correct perpendicular distance from the reference ridge line assure alignment of the hinged panel units in the horizontal plane.

In the deployment of the folded plate system with tension cables, the positive stop offered by the cables aligns the ridge line vertically if the longitudinal variation in height has been corrected by shimming. Tension cables do not, however, guarantee proper ridge line alignment in the horizontal plane. This alignment is accomplished by butting and joining hinged panel units prior to their attachment to edge supports. By deploying and properly seating the first hinged panel unit at one gable endwall, the reference ridge line segment is fixed at one gable peak. By visually sighting on the opposite gable peak in a gunsight manner along the ridge edge fasteners, the alignment of the projected ridge line can be brought into coincidence with the reference ridge line by laterally shifting the panel on its edge supports. Following proper alignment of the first hinged panel unit, the adjacent hinged panel unit is deployed, butted and joined. The alignment of the ridge line to the reference ridge line is checked with the addition of every hinged panel unit. Alternatively, an alignment string is run along the longitudinal edge wall to offer a reference line for alignment in the horizontal plane. Only after the attachment of all hinged panel units is completed, and the proper seating of the panel elements to the gable line is assured are the longitudinal wall and gable supports connected.

8.3 Crane Specifications

For single family residential construction, cranes are typically limited to carrier mounted types. These self-contained units are mounted on a truck or carrier chassis. These hydraulically operated cranes are typically in the 12 to 18 ton range. They are not designed to either pull or transport trailers.

Carrier Crane Specifications and Capacities			
	12 TON	18 TON	35 TON
Width	8'	8'	8'
w/Outriggers	12'	16'	17'
Length	32'-10"	32'-6"	36'-0"
Height	10'	11'-4"	11'-9"
Weight	26 TON	27.5 TON	39.0 TON
Jig length	20'	25'-30'	32'
Cable diameter	1/2"	1/2"	5/8"
Boom length	50'	65'	104'
10'	24,000lbs	36,000lbs	70,000lbs
20'	11,000lbs	14,400lbs	46,800lbs
25'	8,250lbs	12,300lbs	29,400lbs
30'	6,000lbs	10,400lbs	20,560lbs
35'	4,400lbs	9,500lbs	15,450lbs
40'	3,400lbs	8,700lbs	11,400lbs
50'	2,300lbs	6,400lbs	6,600lbs
55'	N/A	5,500lbs	5,280lbs
60'	N/A	4,800lbs	4,090lbs

NOTE: Capacity is reduced when lifting over the sides or front. Reference: Ryan Homes, Inc.

8.4 Roof Panel Width

Roof panel width is dependent on several factors outside of the manufacturing process:

1. Handling
2. Crane limitations
3. Waste
4. Edge stiffener dimension
5. Joining system
6. Transportation limitations

8.4.1 Handling

The size and weight of the roof panels has been developed with the assumption that the construction method will rely on crane assembly. Assuming a minimum panel dead weight of 6 p.s.f. (including roof covering and interior surface), the approximate limiting size of the panel element which can be handled by two men is a twenty-five foot length by one foot width (150 lbs.).

Establishing the role of mechanical lifting devices in panelized roof assembly, the effects of panel size on constructibility needs to be investigated with regard to crane assembly. As panel elements are increased in size, alignment and positioning becomes more difficult, particularly when coupled with increasing vulnerability to wind forces. Full size roof mockups of varying panel widths may be the only method of quantifying the effect of panel widths on constructibility.

8.4.2 Crane Limitations

Considering the common foot prints of detached single family housing, and the difficulty of positioning cranes on tight sites, a boom reach of fifty feet is a required minimum. The load capacity for a fifty foot reach of a twelve and eight-teen ton crane is 2,300 and 6,400 lbs, respectively. No reduction in capacity will be considered from lifting over the sides or front of the carrier vehicle. Assuming a panel dead weight of 10 p.s.f.. (including roof covering and interior surface), a maximum panel length of twenty-five feet, and the deployment of the panel elements in hinged panel units, the twelve ton and the eighteen ton crane are restricted to a panel width of 4'-7" and 12'-9", respectively. Limiting the cranes size to a twelve tons restricts the panel width of hinged panel units to four feet.

8.4.3 Waste

The amount of waste for a simple single bay roof is a function of panel width. Assuming that manufactured panel widths may be cut in half to reduce waste on the total roof area, the average fall-off for a roof of random length can be established. If the panel width is four feet, the half panel width can accommodate roofs of two foot increments. Assuming an uniform distribution in roof lengths (equal probabilistic frequency), the average waste is one-half the incremental roof length, or one-quarter the panel width, or one foot. Similarly, an eight foot panel width results in an average panel waste of one-quarter the panel width, or two feet. One may deduce that the average waste for a simple single bay roof is proportional to the panel width. The effect of panel width on waste for roof complexities such as dormers, turned gables, bastard hips, hipped roofs, etc. are more difficult to characterize.

8.4.4 Edge Stiffner Dimensions

The proportions of the edge stiffner are affected by two factors: girder action, and buckling. The study of thermal and hygroscopic behavior established no effect of panel width on edge stiffener moments. As the aspect ratio of panel length, H , to panel width, b , varied the uniform moment on the edge stiffener remained unchanged. Hence, the area of the edge stiffner with regard to resisting thermal bowing is unaffected by the panel width.

Panel width affects the dimensions of the edge stiffner with regard to its behavior as a girder. The edge stiffner moment increases in proportion to the panel width squared. For a fixed panel depth, the section modulus of the edge stiffner is proportional to edge stiffner width. Thus, the area of the edge stiffner with respect to girder behavior is proportional to the panel width squared.

In practical sandwich designs, panel width does not affect the buckling behavior of the edge stiffner. The allowable unit stress in compression remains unchanged if the b/c

ratio does not exceed 11. For a panel width of eight feet, a panel depth less than 9.6 inches exceeds this criteria. Given the effect of core depths on thermal and hygroscopic behavior, and the long span requirements, this lower limit on core depth cutoff appears reasonable.

8.4.5 Joining System

Panel width affects the joining system. As panel width is increased, loads transferred by the ridge and eave fasteners proportionally increase, however, the number of fasteners proportionally decreases. An eight foot panel width distributes the equivalent tributary load of a single wood truss spaced on twenty-four inch centers. The loads on a four foot panel are one-half this amount with twice the number of ridge and eave fasteners over the entire roof system. As panel widths increase the required number of panel to panel connections decrease proportionally. One could assume a direct correspondence between the number of panel to panel connections and time or cost factors; however, the efficiency of connecting a greater number of fasteners, and the complexity of handling a greater number of building parts may complicate this simplified assumption.

Recall that the optimal location of the two support points for the edge stiffener in terms of minimizing moments, is at the quarter points. Fortunately, this coincides with the modular and dimensional standards of construction. Given a standard roof panel width of four feet, fastener supports occurring at quarter points coincide with a standardized stud spacing of two feet. In this way, loads are collected by the edge stiffener and deposited directly on top of the studs, similar to wood trusses spaced on twenty-four inch centers. Given a panel width of eight feet, fastener supports occurring at quarter points coincide with a standardized sandwich wall panel spacing of four feet. Four foot panel widths in wall panel elements represent the limiting size that a two man crew can handle and are a dimension common to many wall panel systems. Numerous structural sandwich panel wall systems available on the market insert vertical two by four studs into routed panel

edges to join adjacent panels. Loads collected by the edge stiffener could be transferred directly onto these stud reinforced joints. Alternatively, load spreaders inserted horizontally in the top edge of the wall panel element could distribute the concentrated eave edge fastener reactions. For a folded plate or ridge beam system with an eight foot roof panel width, the load collected by the eave edge fastener is comparable to the tributary load of wood trusses on two foot centers.

8.4.6 Transportation Limitations

Transporting panel elements vertically, standing on edge, exposes the fragile panel to panel connections to large impact loads. The alternative solution is to transport the hinged panel units in a horizontal plane. Federal and state statutes on interstate highway transportation place limitations on width dimensions. Extending beyond a panel width of 105 inches entails special permits, limitations on routes, or mandatory escort vehicles, resulting in prohibitive transportation costs and restrictions on site accessibility and scheduling. Thus eight feet and nine inches is established as an upper bound on panel width. The maximum length limit is forty-five feet.

8.5 Crane Deployment

A crane is a necessity in the assembly of these heavy roof panels. The availability of cranes on large scale residential housing projects is increasing. The ability to deploy the hinged panel units rapidly enables a delivery truck equipped with a crane to deploy the panels immediately onto the completed understructure. This building system delivery process is similar to dry wall delivery systems, where a carrier mounted crane transfers the billet of dry wall. Roof trusses are delivered in a similar fashion. The bundled roof trusses are set on top of the longitudinal walls, and are individually positioned by workmen.

Ideally, a trained and certified crew would install the roof system. In this way, the quality of the roof structure can be assured to reduce liability risks for the component manufacturer. The delivery truck driver would also function as the crane operator. The proposed system of crane deployment would require two crew members in addition to the crane operator: one person stationed on the ground, to aid in the attachment of roof panels to the crane jig and assist in panel eave alignment and edge support connections; one person stationed on the roof to position and guide the roof panels into position and make the ridge beam and panel to panel connections. For greater efficiency an additional crew member may be stationed on the roof to assist in roof panel alignment and panel to panel fastening.

The crane deployment sequence is depicted graphically in Figures 8-1 to 8-7. The roof panels are delivered to the site in hinged units. The two ridge edge fasteners and four eave edge fasteners are already attached to the roof panels, Figure 8-1. The crane operator lowers the crane jig to a position where the ground crew member can attach the jig to the two ridge edge fasteners, Figure 8-2. The crane operator raises the jig, Figure 8-3, to a height where the panel eave edge stiffener is located a few feet above the ground within easy reach of the ground crew member. The ground crew member installs the eave crane hooks and attaches the cables which are hanging from the jig to these eave hooks, Figure 8-4. The crew member stationed on the roof then activates, via remote control the lower winch of the double-action winch, Figure 8-5. The jig fixed to the ridge edge fasteners is lowered away from the attachment points of the cables which are fixed to the eave hooks, splaying the panel apart until the proper pitch is achieved, Figure 8-6. If the panel is to be installed on a ridge beam system there are no tension ties between eave edge fasteners to prevent the panel from splaying beyond the proper pitch. A string of determined length could be attached in the factory between eave ends. A taut sting would serve as an indicator that the approximate pitch has been achieved. Splaying the panel beyond the

proper pitch would snap the string. The crane operator positions the hinged panel unit to the approximate ground plan coordinates and a slight distance above the final position. The crew member stationed on the roof activates the upper winch via remote control to adjust the height of the hinged panel unit, Figure 8-7. In this way the person who can most easily observe the needed corrections in height and pitch of the hinged panel unit can fine tune their adjustment by activating, via remote control, the double action winch. After correct alignment of the roof panel, the crew member stationed on the roof detaches the ridge hooks. The sequence is repeated for the remaining roof panel elements.

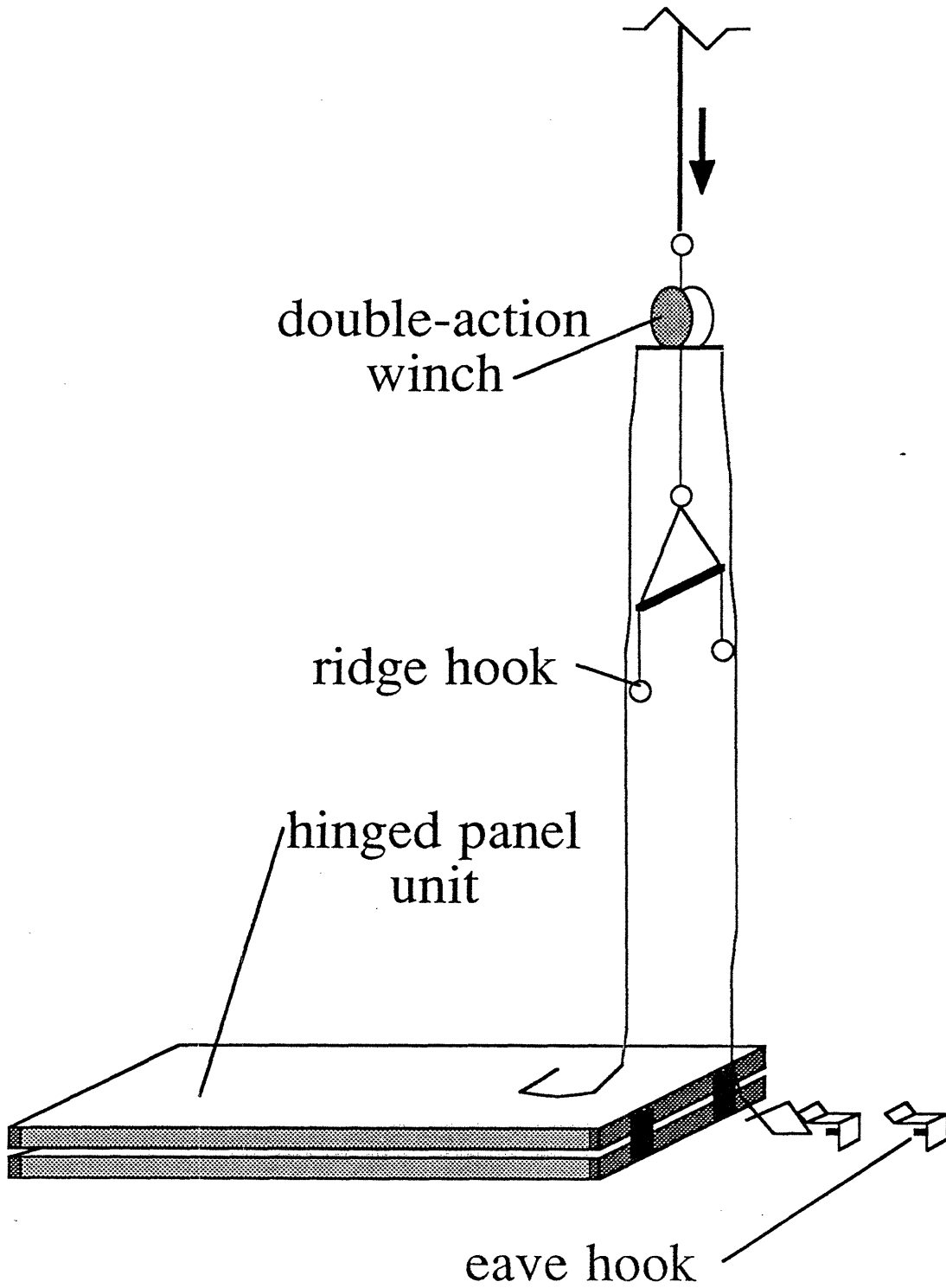

Figure 8-1: Crane Deployment Sequence

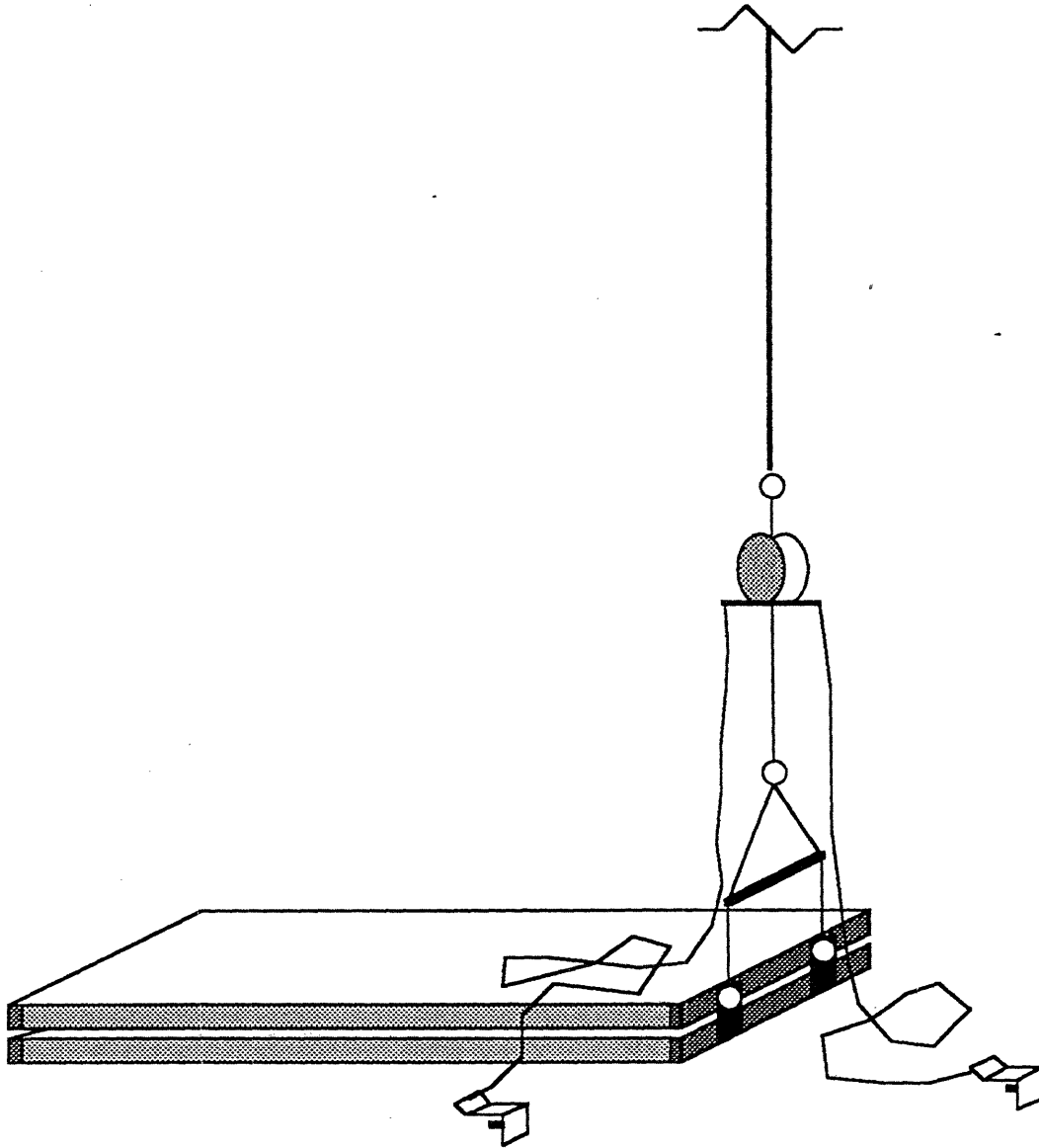

Figure 8-2: Crane Deployment Sequence

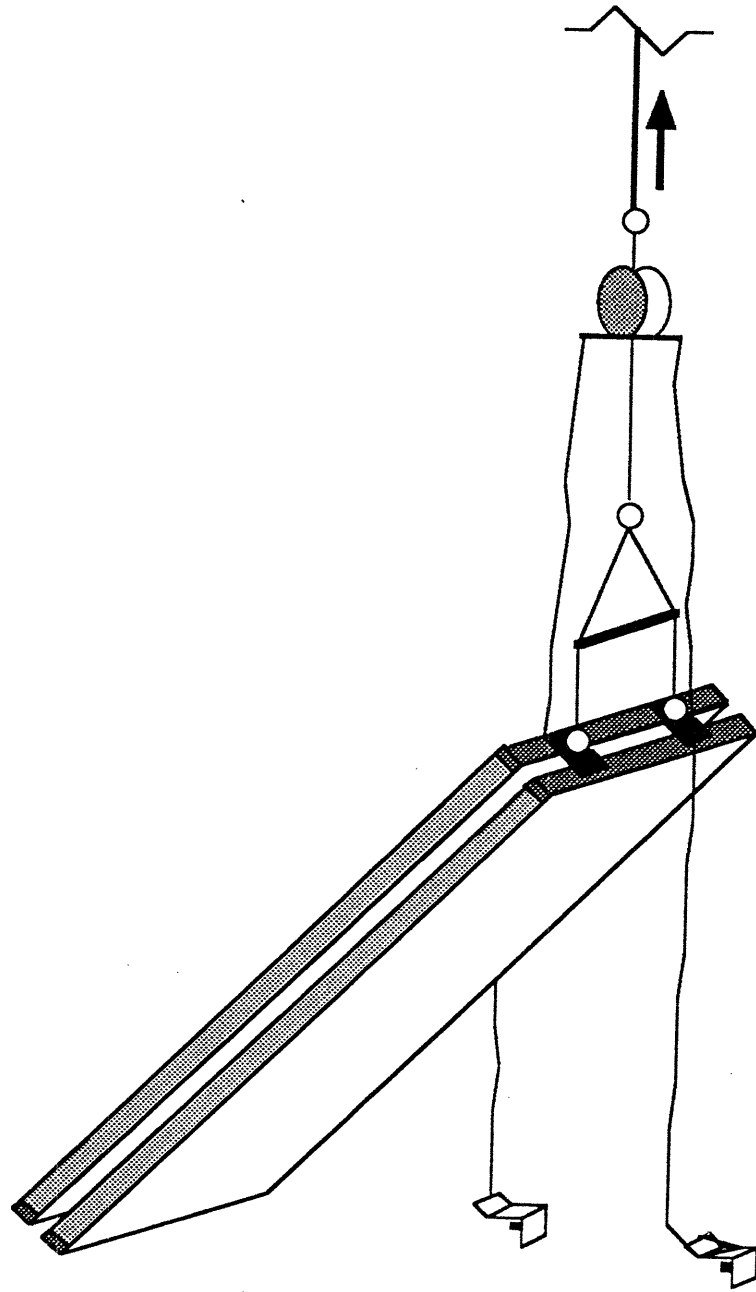

Figure 8-3: Crane Deployment Sequence

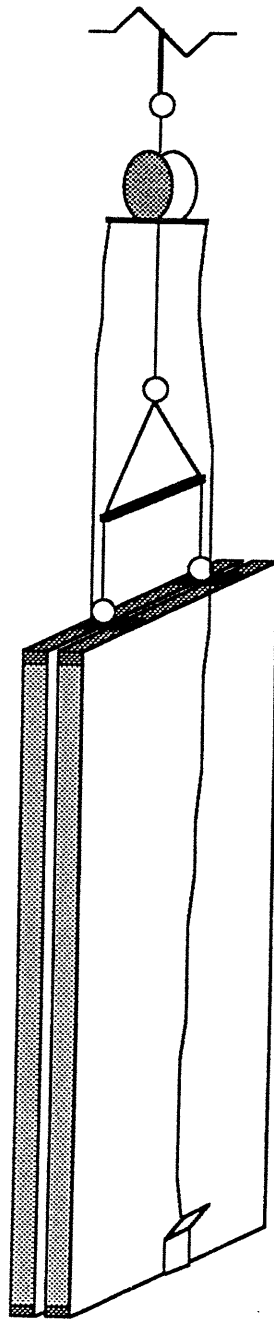

Figure 8-4: Crane Deployment Sequence

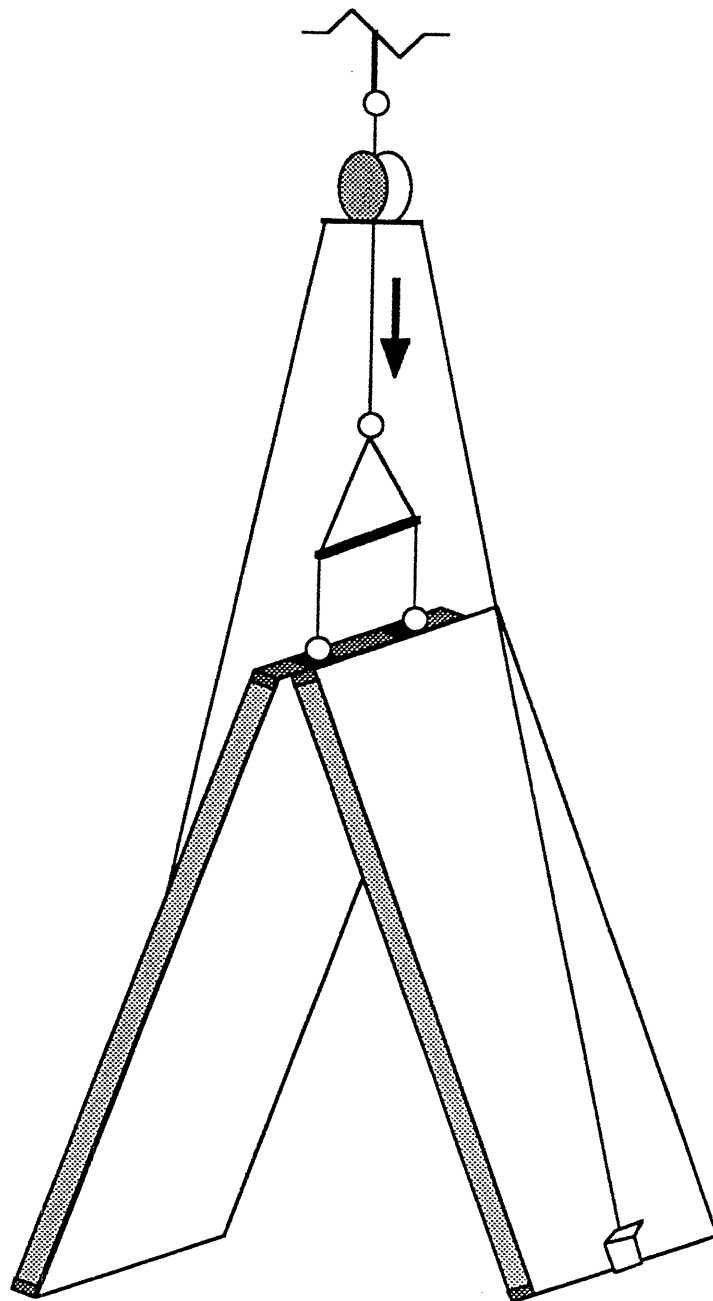

Figure 8-5: Crane Deployment Sequence

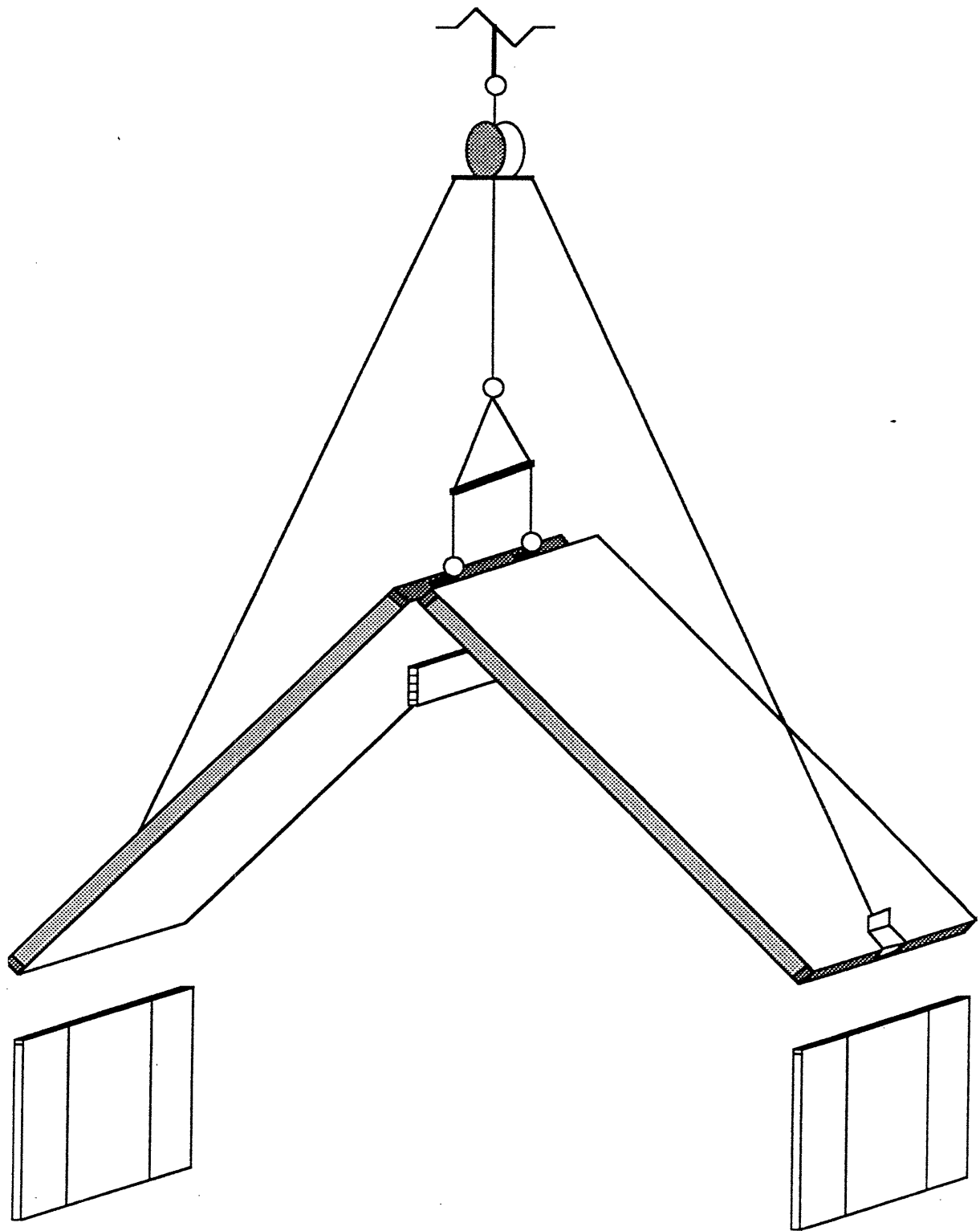

Figure 8-6: Crane Deployment Sequence

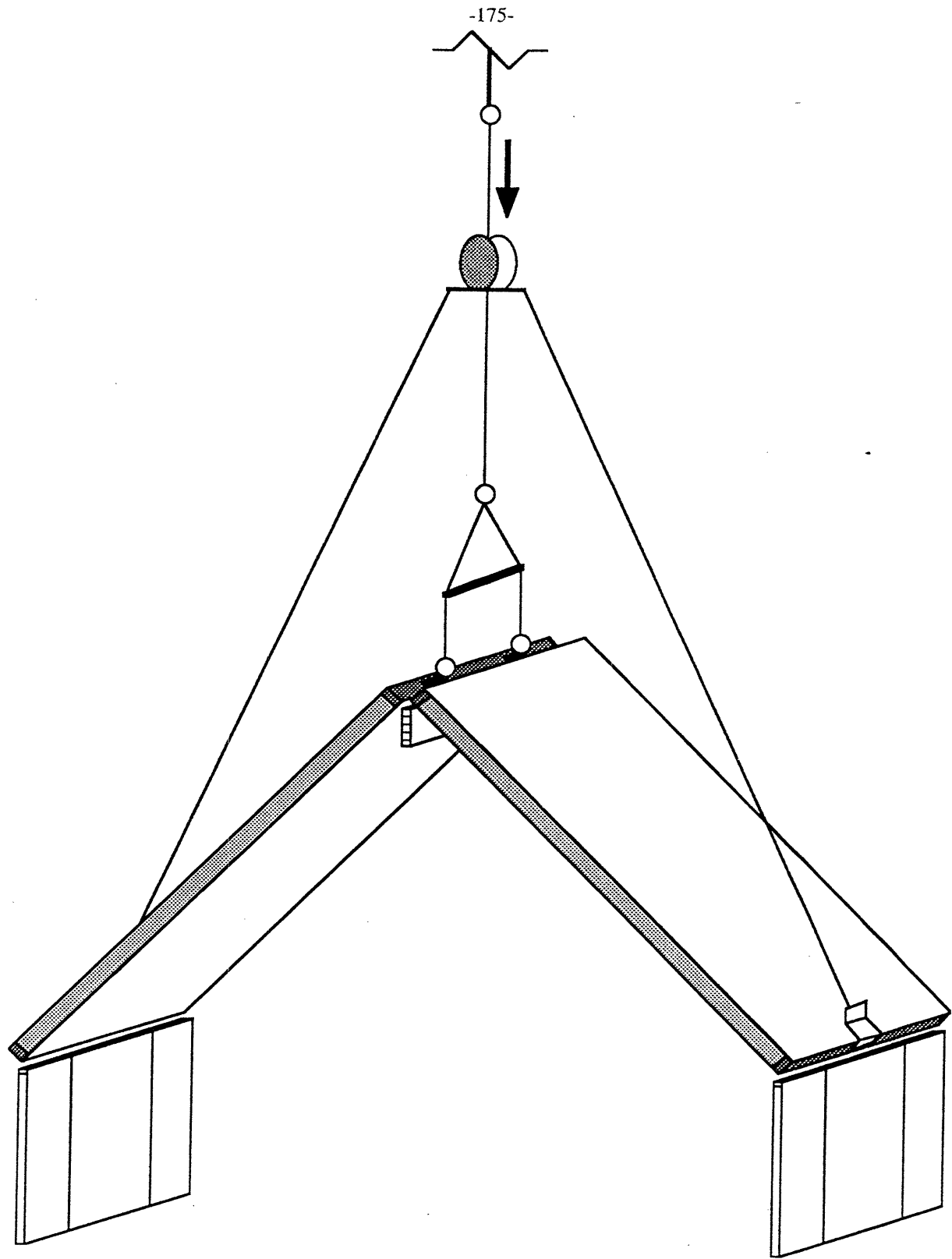

Figure 8-7: Crane Deployment Sequence

8.5.1 Lifting and Hooking

The hinge panel units are lifted and rotated open by attaching crane hooks to the ridge edge fastener (refer to Figure 8-8). The hinge pin extends beyond the cylindrical barrel of ridge edge fastener to facilitate crane attachment. The hinge pin is crimped or mushroomed at either end after insertion in to the hinge to prevent the pin from working free. The crane ridge hook is fabricated from a bent rectangular steel bar. The two halves of the ridge hook are joined by an offset ridge hook hinge which allows the ridge hook to spread apart. An enlarged hole in the ridge hook passes over the crimped or mushroomed pin diameter. This enlarged hole constricts to an elongated slot the width of the hinge pin shank. The mushroomed hinge pin ends keeps the ridge hook plates against the point of emergence of the pin from the hinge. If the ridge hooks were to move away from direct contact with the hinge, bending stresses could result in failure of the hinge pin. It is also required that the eave ridge hook be prevented from disengaging the ridge edge fastener if the load were unintentionally released. This load release might occur if tension cables are attached from eave to eave. The tension cables would resist the lateral thrust of the panel dead weight should the lower winch continue to be let down beyond the proper pitch. Ridge hook release in the event of load release is prevented by the addition of a flip down guard which fills the remaining portion of the enlarged hole and prevents the pin from being jarred out of the elongated slot.

8.5.1.1 Ridge Crane Hook

The eave crane hook is designed with regard to constructibility (refer to Figure 8-9). The eave hook attaches to the eave edge stiffener by the insertion of a round metal stub into a hole pre-drilled in the eave edge stiffener. The hole is located at midspan of the panel width to balance the suspended weight and at mid-depth of the edge stiffener to be in a region outside of the critical stresses due to combined axial and bending loads. The eave edge stiffener should be designed considering this reduced section. The eave hook is held

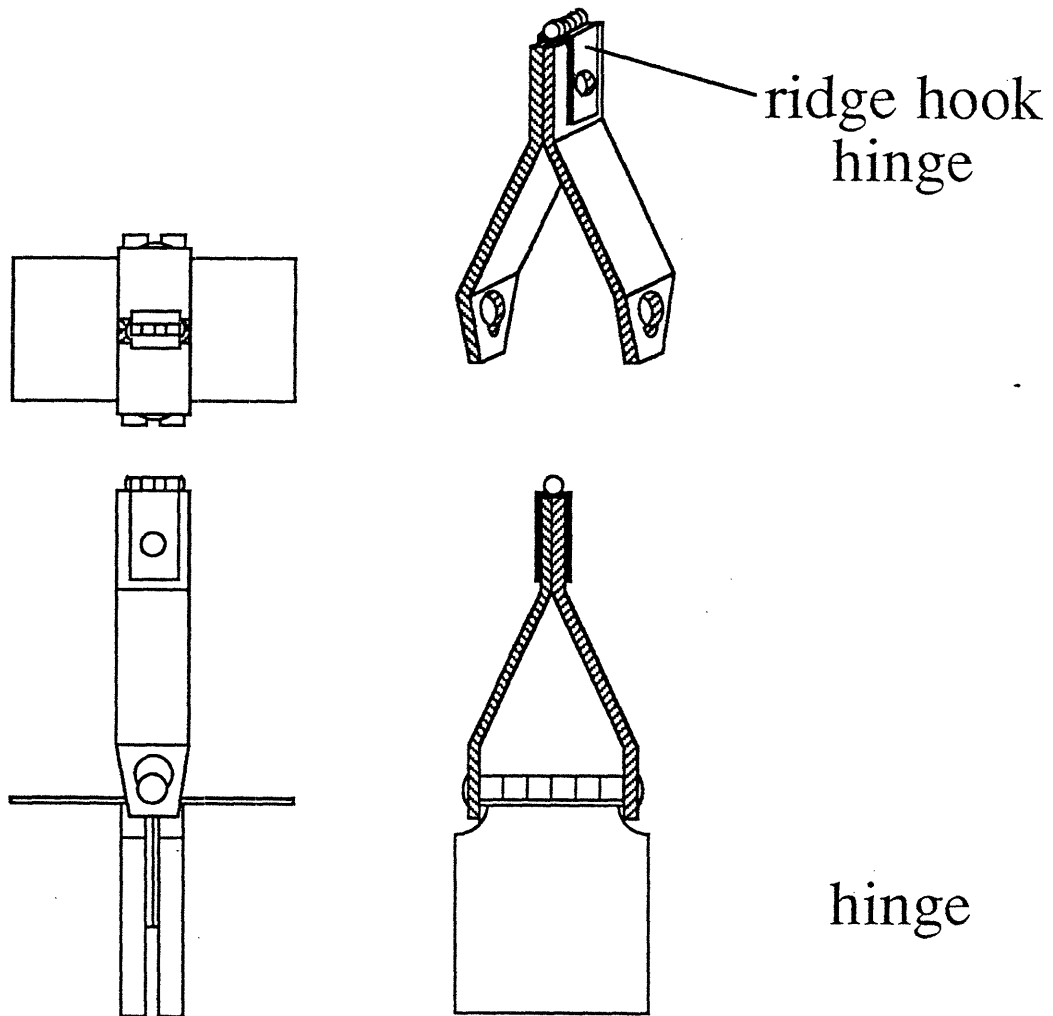

Figure 8-8: Ridge Crane Hook (refer to Figure 7-5 for hinge orientation)

in place by the tension load of the cables extending to the double-action winch. To hold the eave hooks in place before the cables can be tensioned, a double headed scaffold nail is driven through a pre-drilled hole in the eave hook into the eave edge stiffener.

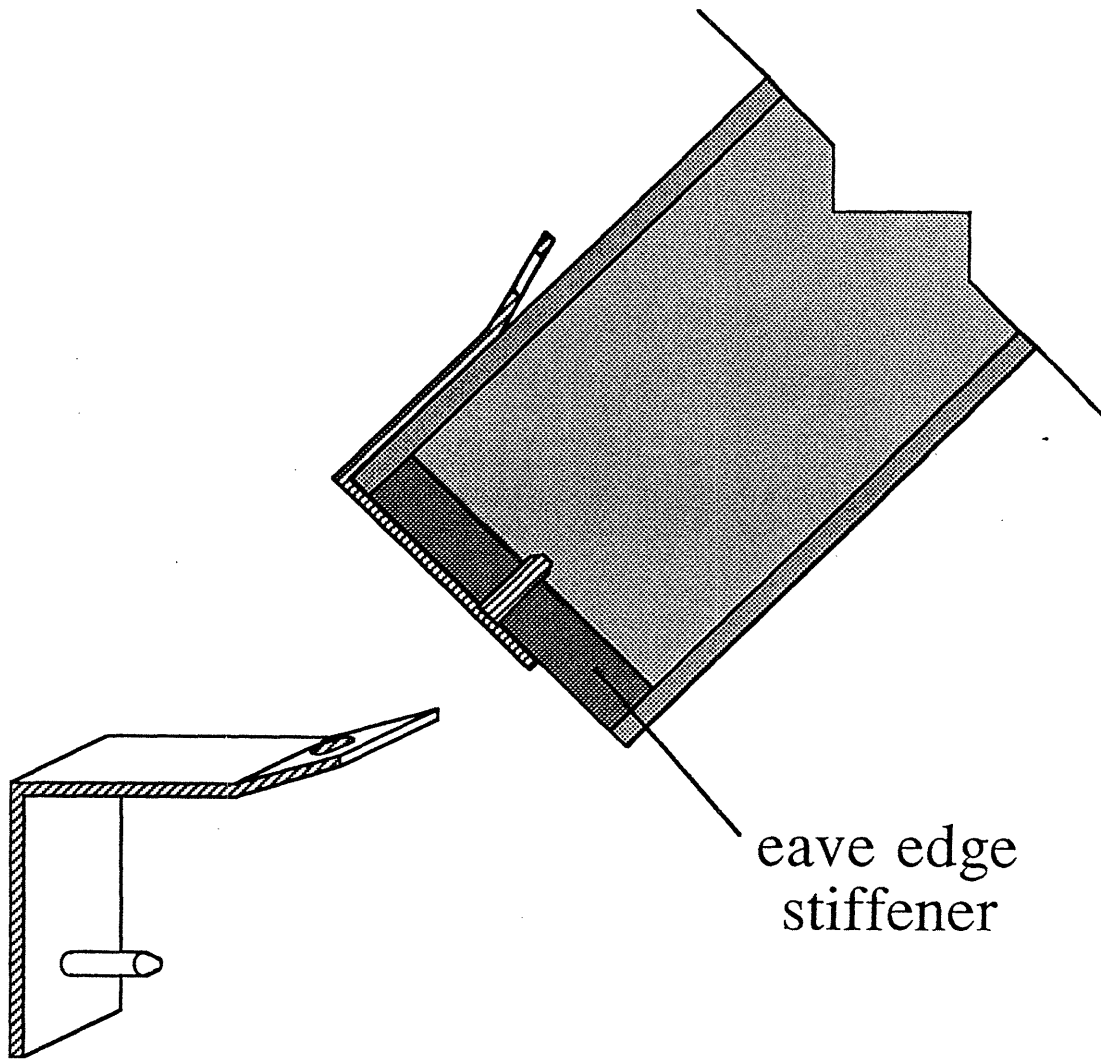

Figure 8-9: Eave Crane Hook

8.5.1.2 Double-Action Crane Winch

The double action winch would be activated by a two channel remote control. Two servos would activate the control of upper and lower winch action. One motor could drive both upper and lower winches by a bendix switch gear. A variable speed motor controlled by the servos would decrease deployment times and aid in fine adjustments of pitch and

height. The motor could be driven by either an electric generator, or power hook up on site. The retractable power cable is suspended off the crane boom, so as not to interfere with deployment.

Chapter 9

Conclusions

In Part I, the structural analysis and design of sandwich panels for folded plate, ridge beam and floor tied systems were developed and explored for various joining options and roof geometries. The critical effects of thermal and hygroscopic gradients on sandwich panel behavior were examined. Closed form solutions of restrained two-way slabs exposed to thermal or hygroscopic gradients indicated that both had a severe impact on panel design. Large edge (infinite corner) reactions and stresses develop if panel slab edges are restrained from bowing. Deformations due to thermal and hygroscopic gradients are inversely proportional to the panel depth, and severely reduce panel stiffness performance. Joint loads as determined by the Uniform Building Code were examined for critical parameters to establish a representative upper limit load case and are compiled in the form of load tables for various roof geometries (Appendix E.1).

Program *panel.f* designs sandwich panels for a folded plate and ridge beam system incorporating into its program code the body of the knowledge presented in Part I. This fortran program provides the capability to quickly analyze and study roof system performance for various materials, panel types, geometries, loads, and roof systems. Included in Appendix A.4 are hard copies of program output for the case of a composite panel with an oriented strand board face (O.S.B.) and a rigid polyurethane core (P.U.) for a typical roof geometry and the standard load case (see Chapter 6).

The importance of the effect of thermal and hygroscopic gradients on panel design, which has been overlooked by the code bodies, can be examined by relaxing the thermal gradient criteria of program *panel.f*. Two load cases are examined for O.S.B. faces and a P.U. core: a panel exposed to a typical thermal gradient (*panel.f* output pages 1-2); a panel

with no thermal gradient exposure (*panel.f* output pages 3-4). The impact of thermal gradients deformations on panel design, which is typically controlled by stiffness, is significant. The face thickness is increased by 60% when considering the affects of thermal gradients for a core depth of 12 inches. The effect of thermal gradients on panel design increases as the core depth is reduced. The face thickness is increased by 70% when considering the affects of thermal gradients for a core depth of 9 inches. The panel design which is subjected to a thermal gradient is more costly and heavier than a panel design which is not.

The success of the proposed roofing system is directly linked to the development of suitable materials. The output of *panel.f* questions the use of materials common to the foam sandwich market in long span sandwich panels (*panel.f* output pp. 1-2). One inch thick O.S.B. faces are required for a P.U. core depth of twelve inches. Shear deflections due to the polyurethane core are large (shear deflections are 500% of the flexural deformations for a 12 inch core depth, with a creep factor of four), thermal requirements of R30 are exceeded (R74.5 for a 12 inch core), material costs are high, and the fire performance of polymeric material is low. Hence, research on core materials is in concert with the structural explorations of long span sandwich panels.

Thermal and hygroscopic behavior controls the selection of core and face and materials. Since deformations due to gradients are inversely proportional to the core depth, the panel design is driven towards deeper panel sections. A stiffer, less expensive and less thermally efficient core material than P.U. is desirable. Current research into reinforced, polymer cementitious foams could provide an insulating structural foam core which is low cost, has good insulating value, fire performance, shear stiffness, and creep properties. Face material selection is controlled by the thermal and hygroscopic expansion coefficients. Gradient deflections are proportional to the expansion coefficients. Materials which are thermally and moisture sensitive are either less efficient in composite design, or must be protected from such effects.

A sandwich panel type utilizing a structural non-insulating core (such as a phenolic-impregnated paper honeycomb) with supplemental insulation added to the exterior of the panel (P.U.) removes the problematic thermal gradient. The outside face is protected from exposure by the exterior insulation. Unlike a panel with a structural insulating core, this panel type allows for the venting of the non-structural exterior insulation without interfering with the structural performance of the sandwich core.

The proposed roof system of thesis Part II is a prototype for a commercially viable roof system. The system provides an elegant, simple and constructible roof system for the residential market. The basis for the roof system's development was to reduce the number of parts in the field, allow for joint intolerance, increase flexibility and adaptability to various structural roof and wall systems, and to provide a quick, non-labor intensive joining system. The attributes of the system are as follows:

1. Time required for the roof enclosure would be drastically reduced from that of traditional roofing systems.
2. Exterior roof membranes and interior finishes can be incorporated in the composite panel structure.
3. The proposed system is adaptable to a folded plate, ridge beam or floor tied system.
4. The system is compatible with both wood frame and panelized wall systems.
5. Joint design allows for mis-alignment of wood frame construction to be taken out at critical connections.
6. Redundancy in the folded plate is provided by a number of construction alternatives.
7. On-site connections are limited to: a small number of high strength bolts at the tension splice, installation of two lag bolts per hinge and the shoe attachment in the ridge beam system, fastening of the gable fascia board, and the shimming and fastening of the eave connection.

9.1 Recommendations for Further Research

Recommendations for continued work on the subject of this thesis are as follows:

1. Construct and test the proposed joint designs, or improved versions. Test full-scale joints on a small frame testing machine (60 kips) to verify design assumptions. Erect full-scale mockup designs to study constructibility and the crane deployment sequence.
2. Study the tolerance limitations of the panel elements and their effect on panel fabrication and roof system precision with the joining system.
3. Quantify the thermal exposure of the exterior panel face. Study the performance of roof membranes subjected to these temperatures. Investigate means of alleviating the problem by exterior surface coatings or venting.
4. Continue the finite method analysis of the thermal behavior of rectangular sandwich panels supported at the quarter points of an edge stiffener.
5. Study the transverse shears (normal to the roof surface) which developed due to the exposure of one sandwich panel element to thermal gradients while the adjacent panel element is not exposed.
6. Study the problem of vapor control in the roof system, and its effect on long-term panel performance and hygroscopic behavior. Examine various methods of abating the problem: vapor barriers, venting, wicking, self-drying, etc.
7. Examine roof complexities: dormers, turned gables, hipped gables, bastard gables, skylights, etc., and how they can be incorporated into the roof system.
8. Investigate the thermal short-circuiting of the panel by the panel web with the aid of finite element analysis or thermal testing
9. Continue the development on a joining system for a stress-skin panel and a non-insulating structural core sandwich panel construction.
10. Establish the desired level of structural reliability for the system. Determine the governing variability of resistance, load, and the consequences of failure.
11. Examine interior finishes and roofing membranes to be incorporated into the fabricated sandwich panel. Address the problem of sealing and finishing the joints on site.
12. Transfer the technology learned from the roof system into a floor and wall system.

Computer Program Appendix

The appendix includes computer programs utilized in analysis and design.

Panel.f, a fortran program, designs a sandwich panel for a single bay residential roof (Appendix A). The program designs a roof panel spanning from ridge to eave in beam action, but can optionally design a single bay, simple span, folded plate. The program optimizes the design of a sandwich panel with respect to cost for a given required R value, load, geometry, material properties, thermal and hygroscopic bowing, and deflection constraints. The user is presented with the choice of two design concepts: faces plus either an insulating core, or a non-insulating core with insulation added to the exterior of the panel.

Included in the appendix are two fortran programs which analyze joint loads according to UBC '88. In both programs the live, dead, wind and seismic loads and their respective parameters are interactively input, and the resulting load tables for varying pitch, gable to gable length, and eave to eave width are calculated. Program *sep.f* generates load tables for the individual effect of dead, live, seismic, and wind loads on the eave, gable and ridge line (Appendix D). Program *comb.f* combines the separated load effects according to UBC '88 specifications (Appendix E).

S.f is a fortran program which calculates the deflections, shear stresses, bending stresses, twisting stresses for a rectangular isotropic sandwich panel with: two edges simply supported, the other two edges free; four edges simply supported.

Program *B.f* is a fortran program which calculates the reaction along the panel edges for a rectangular isotropic sandwich panel with: two edges simply supported, the other two edges free; four edges simply supported.

Hard copies of the computer programs utilized and developed for the roof system

analysis are included in this appendix. Example output for the various programs are attached behind each file hard copy. The data input in the programs is given in the hard copy of the program output. Oriented strand board, and a polyurethane foam core are the materials input into the *panel.f* program. The standard load case parameters established in Chapter 6 are input into program *sep.f* and *comb.f*.

The attached 1.2M double sided, high density floppy disks containing the programs *panel.f*, *sep.f* and *comb.f*. The programs are written in Athena Fortran f77 (UNIX program) and compiled on a VAX station 2000.

Appendix A

Program Panel.f

A.1 Program Variables

ap = Transformed area of transverse cross section through the panel (in.²).

adefl = Allowable flexural deflection for live load only (in.).

adefld = Allowable flexural deflection for live and dead load (in.).

arcf = Ratio of core to face thickness (-).

b1 = Constant in the face wrinkling equation (-).

b2 = Horizontal distance between gable lines (in.).

c = Constant in the quadratic equation solution (-).

ca = Cost of structural adhesive per square foot (\$.s.f.).

cai = Cost of non-structural adhesive per square foot (\$.s.f.).

cc = Cost per board foot of core material (\$.b.f.).

ccost = Least cost for panel solution, initially set to be very high (\$).

cf = Cost per board foot of face material (\$.b.f.).

ci = Cost per board foot of exterior insulation material (\$.b.f.).

copy = Does the user want a hard copy of the data sent to file *hard*? (y/n)

cq = Wind coefficient factor from U.B.C. code for roof elements (-).

cr = R value of the core (hr*ft²*°F/BTU*in).

creepc = Creep factor for out-of-plane shear modulus of core material based on transient live load (-).

creepf = Creep factor for Young's modulus of face material in transverse direction based on transient live load (-).

csigpx = Stress in the core due to "plate" action in the longitudinal direction (p.s.i.).

ctaupxy = In-plane shear stress in the core due to "plate" action (p.s.i.).

ctr = R value of the core and faces ($\text{hr}\cdot\text{ft}^2\cdot^\circ\text{F}/\text{BTU}\cdot\text{in}$).

cut = Would you like to examine stresses in a transverse cut through the folded plate?(y/n)

d = Vertical projected distance between fold line and eave line (in.).

de = Total "plate" deflection due to splice deflections in eave line member (in.).

dep = "Plate" deflection due to splice deflections in eave line member (in.).

NOTE: Splice deflection for eave line slip must be entered into the program for the panel joining system.

defl = Calculated deflection of the composite panel for live load only (in.).

defld = Calculated deflection of the composite panel for dead and live load (in.).

deflm = Maximum deflection of the composite panel (in.).

df = Flexural "plate" deflection (in.).

dh = Calculated horizontal eave deflection (in.).

ds = Shear "plate" deflection (in.).

dseg = Distance between points where stresses are examined in a transverse cut through a folded plate. (in.).

dss = Total seam slip "plate" deflection (in.).

dssp = Seam slip calculated from equation relating seam slip to in-plane shear.

NOTE: Seam slip equation must be entered into the program for the panel joining system.

Seam slip does not occur if the panel elements are glued together.

dtc = Incremental production thickness of the core material (in.).

dtf = Incremental production thickness of the face material (in.).

dte = Incremental production thickness of the exterior insulation material (in.).

dv = Calculated vertical ridge deflection (in.).

e = Young's modulus of the face material in the transverse direction (k.s.i.).

eavea = Area of eave line member (in.^2).

eavee = Young's modulus of the longitudinal line member material (k.s.i.).

ec = Young's modulus of the core material in the transverse direction (k.s.i.).

eco = Young's modulus of the core material in out-of-plane direction (k.s.i.).

ecp = Young's modulus of the core material in the longitudinal direction (k.s.i.).

ef = Increased Young's modulus of the face material (e) due to wide beam effects (k.s.i.).

ei = Flexural rigidity of the composite panel in the transverse direction (lb*in.²).

ep = Young's modulus of the face material in the longitudinal direction (k.s.i.).

eratio = Ratio between Young's modulus of the core and the face material for the longitudinal direction (-).

exit = Do you really want to leave the program? (y/n)

ext2 = 1, Faces and an insulating, structural core. (-).
= 2, Faces, structural core, and a non-structural insulation added to the exterior (-).

fcoeff = Thermal coefficient of expansion for face material (10⁻⁶/°F).

fctau1yz = Out-of-plane shear stress in the face and core due to "one-way slab" action (p.s.i.).

fdh = Final horizontal eave deflection of least cost panel (in.).

fdv = Final vertical ridge deflection of least cost panel (in.).

fh = Allowable horizontal deflection at the eave line (in.).

fhygro = Hygroscopic strain gradient for face material (-).

fl = Allowable displacement factor for panel bending for live load only, i.e. defl.=span/factor (-).

fdl = Allowable displacement factor for panel bending for dead and live load, i.e. defl.=span/factor (-).

fold = Is the designer interested in folded plate design? (y/n).

fsg1 = Calculated stress in the face of a composite panel (k.s.i.).

fsg1y = Stress in the face due to "one-way slab" action in the transverse direction (p.s.i.).

fsgpx = Stress in the face due to "plate" action in the longitudinal direction (p.s.i.).

ftaupxy = In-plane shear stress in the face due to "plate" action (p.s.i.).

ftc = Final core thickness of least cost panel (in.).

ftf = Final face thickness of least cost panel (in.).

fti = Final exterior insulation thickness of least cost panel (in.).

fwd = Final dead weight of least cost panel (p.s.f.)

fvaluer = Final R value of the least cost panel ($\text{hr}\cdot\text{ft}^2\cdot^\circ\text{F}/\text{BTU}\cdot\text{in}$).

fv = Allowable vertical deflection at ridge line (in.).

fx = Tension load in eave line member (lbs.).

gc = Out-of-plane shear modulus of the core material (k.s.i.).

gcp = In-plane shear modulus of the core material (k.s.i.).

gf = Shear modulus of the face material (k.s.i.).

gratio = Ratio between in-plane shear modulus of the core and the face material (-).

h = Slope distance between the fold line and the eave line (in.).

hard = Name of file to which hard copy output is sent, sequentially (-).

Note: Must be removed from the directory before executing beam.f

ien = Integer value of the number of panels needed to cover half the roof minus one (-).

ip = Moment of inertia of a transverse cross section of the panel (in^4).

l = Longitudinal length of span between gable lines (in.).

line = Does the folded plate utilize longitudinal line members? (y/n)

mode = Number assigned to the controlling design constraint (-).

mp = Maximum moment created by the in-plane load ($\text{lb}\cdot\text{in}$).

mrcf = Minimum ratio of thickness of core to thickness of face to be considered (-).
A ratio of 3 is recommended.

mtc = Maximum depth to be considered for the core (in.).

mtf = Minimum thickness of the face material (in.).

nseg = Number of points at which stresses are examined in a transverse cut through a folded plate (-).

p = Pitch of roof, i.e. 6, means a slope of 6 to 12 (-).

page = Page number of the output (-).

pip = Pitch ratio of roof (-).

pw = Width of the panel element (in.).

q = Calculated out-of-plane shear stress in the core (k.s.i.).

quad(a,b,c,t) = Subroutine to solve quadratic equation (-).

r = R value required for the roof panel ($\text{hr}\cdot\text{ft}^2\cdot\text{°F}/\text{BTU}\cdot\text{in}$).

rad = Angle between the folded plate and the horizontal in radians (-).

rc = R value per inch of the core material ($\text{hr}\cdot\text{ft}^2\cdot\text{°F}/\text{BTU}\cdot\text{in}$).

reanal = Would the user like to change panel configuration? (y/n)

recut = Would the user like to make another transverse cut? (y/n)

rf = R value per inch of the face material ($\text{hr}\cdot\text{ft}^2\cdot\text{°F}/\text{BTU}\cdot\text{in}$).

ri = R value per inch of the exterior insulation material ($\text{hr}\cdot\text{ft}^2\cdot\text{°F}/\text{BTU}\cdot\text{in}$).

ss = Maximum shear stress in the face at the gable line (k.s.i.).

scost = Calculated cost of the panel (no roof or interior finishes) per board foot (\$.b.f.).

switch = Would you like to switch from a panel with no exterior insulation to one with, or visa versa? (y/n)

tc = Thickness of core (in.).

tempaw = Appropriate winter difference in average temperature of the outer and inner face (°F).

temp = Maximum summer difference in average temperature of the outer and inner face (°F).

tempw = Maximum winter difference in average temperature of the outer and inner face (°F).

tf = Thickness of face (in.).

tfd = Face thickness determined by the deflection constraint (in.).

tfdead = Face thickness used to calculate dead weight of panel (in.).

tfi = Thickness of the face material as required to meet the required R value of the panel (in.).

tftp = Face thickness determined by the folded plate deflection constraint (in.).

tfu = Face thickness determined by the all design constraints, not rounded up (in.).

tfw = Face thickness determined by the face wrinkling criteria (in.).

tfy = Face thickness determined by the face yielding criteria (in.).

tidead = Exterior insulation thickness used to calculate dead weight of panel (in.).

trr = Intermediate value to round up material thicknesses (in.).

valuer = Calculated R value of the panel ($\text{hr}\cdot\text{ft}^2\cdot^\circ\text{F}/\text{BTU}\cdot\text{in}$).

vc = Poisson's ratio of the core material (-).

vf = Poisson's ratio of the face material (-).

vx = In-plane shear at a distance x from the midspan (lbs.).

wcc = Weight of core material (p.c.f.).

wd = Dead weight of panel (p.s.f.).

wfc = Weight of face material (p.c.f.).

wfs = Constant to determine the critical face wrinkling thickness (-).

wic = Weight of exterior insulation material (p.c.f.).

wis = Weight of interior finish material (p.s.f.).

wl = Reduced live (snow) load per unit horizontal projected area (p.s.i.).

wli = Imputed live (snow) load per unit horizontal projected area (p.s.i.).

wlc = Controlling live load (p.s.f.).

wp = In-plane load carried by "plate" action (lbs./in.).

wrs = Weight of roofing material (p.s.f.).

w_s = Total transverse load per unit width (lb./in.).

w_w = Wind pressure normal to the roof (p.s.f.).

x = Longitudinal distance from origin at midspan of the roof (in.).

x_l = Longitudinal distance from the left gable line of the roof (in.).

y = Transverse distance from the midspan of the folded plate roof (in.).

y_{sc} = Design value for the critical shear stress of the core material (k.s.i.).

y_{sf} = Design value for the critical flexural stress of the face material (k.s.i.).

y_{sl} = Design value for the critical tension or compressional stress of the longitudinal line member material (k.s.i.).

y_{ss} = Design value for the critical shear stress of the face material (k.s.i.).

A.2 Program Description

Panel.f, a fortran program, designs a sandwich panel for a single bay residential roof. The program designs a roof panel spanning from ridge to eave in beam action, but can optionally design a single bay, simple span, folded plate. The program optimizes the design of a sandwich panel with respect to cost for a given required R value, load, geometry, material properties, thermal and hygroscopic bowing, and deflection constraints. The user is presented with the choice of two design concepts: faces plus either an insulating core, or a non-insulating core with insulation added to the exterior of the panel.

The user inputs the geometry, loads, deflection constraints, thermal or hygroscopic gradient, required R value, and material properties. Additionally, the user inputs the minimum production thickness and the incremental production thickness of the materials. The program yields solutions which are of production stock. The user is required to enter the maximum thickness to be considered for the core. This value is commonly dictated by

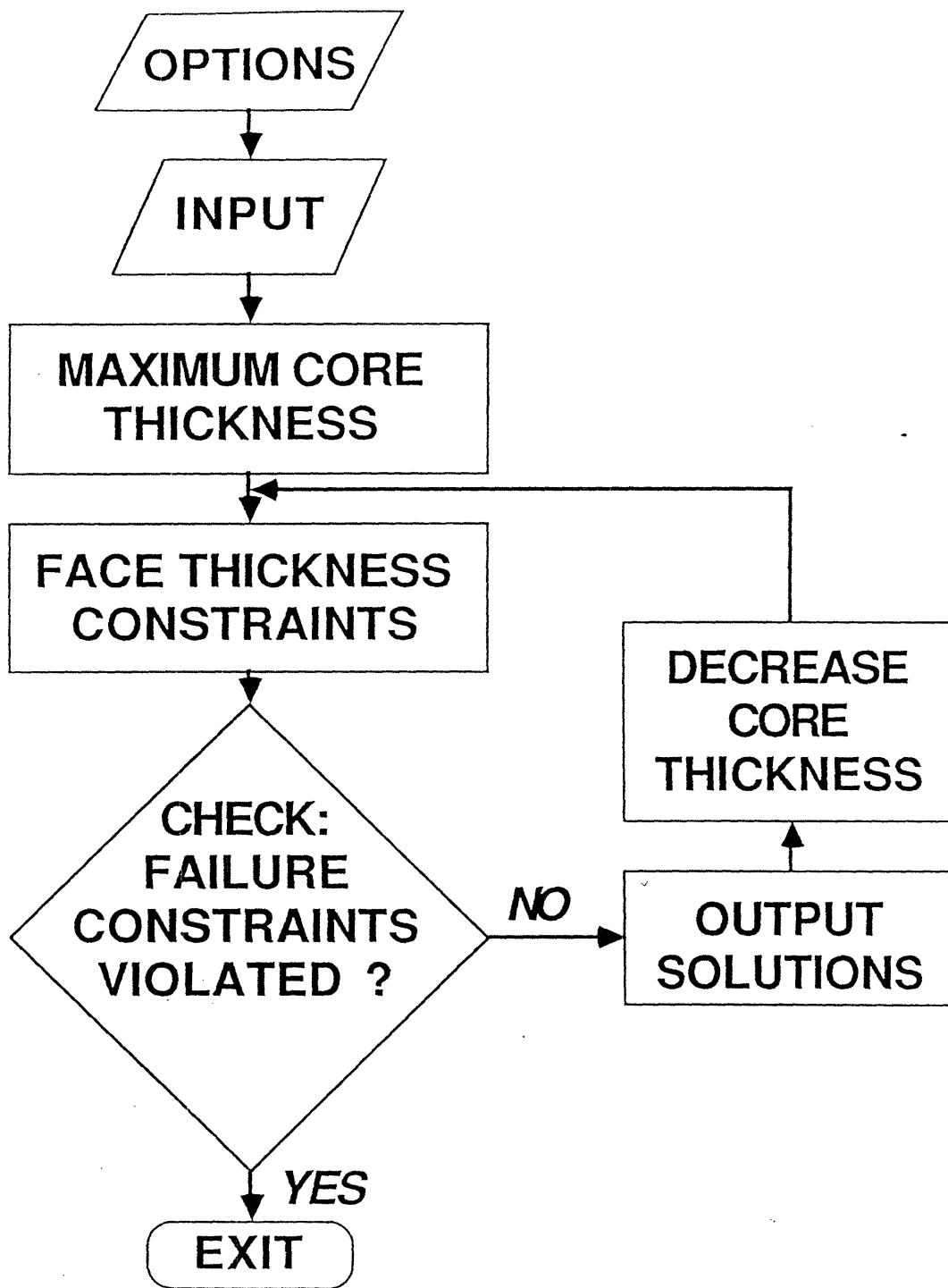

Figure A-1: Program *Panel.f* Flowchart

architectural constraints (a value of 12" is suggested). A maximum ratio of core to face

thickness to be considered in the panel solutions is required of the user. A very low core to face thickness ratio results in inaccurate analysis, due to shear lag, and a heavy, inefficient sandwich panel (a value > 3 is recommended).

The program begins by setting the core thickness equal to the maximum core thickness to be considered. The algorithm solves for the face thickness meeting the design constraints of: deflection, face yielding, face wrinkling, thermal R value, and if a folded plate: ridge and eave deflections, and in-plane shear yielding of the faces. Before a solution is deemed viable, a check is made on the ratio between the core to face thickness, and core shear failure. If the panel passes both of these checks, the panel solution is displayed on the screen. Following this, the core thickness is reduced by an incremental production thickness, and the algorithm for solving for face thickness (checking failure) is repeated. This loop continues until the panel either violates the core to face thickness ratio or the core fails in shear. The details of the program follow.

After the data has been imputed into the program interactively, the headings for the solution output are created. The increase in the Young's modulus due to wide beam action is calculated. The program calculates various geometric and material parameters. The program begins by setting the core thickness equal to maximum core thickness to be considered. The face thickness is set equal to the minimum face thickness produced. The live snow load, if over 20 p.s.f. is reduced for each degree of pitch over twenty degrees, according to UBC 88 code. The dead weight of the panel and the most critical transverse load is calculated. Next, deflections are computed from deflection constraints. Each constraint is assigned a respective mode number:

1. Mode 2.1 = Live load deflection constraint, including: controlling live load, a creep factor, and appropriate winter temperature differences.
2. Mode 2.2 = Dead and live load deflection constraint, including: controlling live load, dead load, a creep factor, and appropriate winter temperature differences.

3. Mode 2.3 = Live and dead load deflection constraint, including: outward wind pressure, maximum summer temperature differences, and dead load.
4. Mode 2.4 = Live and dead load deflection constraint, including: outward wind pressure, hygroscopic gradient, and dead load.
5. Mode 2.5 = Live and dead deflection constraints, including: inward wind pressure, maximum winter temperature differences, and dead load.

The deflection of the panel is the movement of the panel away from a straight line drawn from eave to ridge. If the deflection criteria is satisfied the program continues, otherwise the face thickness is increased by an incremental production thickness; the program returns to recompute the deflection and re-compares it to the deflection constraint. Following this the program compares the stresses in the face material to their design critical flexural stress value. If the critical stress is exceeded, the program increments the face thickness of the face until this constraint is satisfied (mode equals 3.0); the program next checks face wrinkling. The compression face of a sandwich beam with an isotropic core is examined for face wrinkling utilizing a method described by Allen [69]. The face thickness obtained for face wrinkling is then compared to the existing value for the face thickness. The face thickness is set equal to the larger value (mode equals 4.0). If the user choose the design concept of faces and core with no non-structural insulation added to the exterior the only possible way to satisfy the R value requirement is to increase the face thickness since the core thickness is held constant (mode equals 5.0). Additionally, if the designer choose a folded plate concept the ridge and eave deflections may exceed the allowable deflections and the face thickness must be increased incrementally until deflections are within acceptable limits (mode equals 6.0). The program calculates the area of the longitudinal line members based on strength requirements. *NOTE: The equation for the seam slip deflections as a function of in-plane shear is not entered into the program, and must be entered for the specific panel joining system. Seam slip does not occur if the panel elements are glued together. Additionally, the equation relating eave line splice*

deflection to tension force must be entered. Following this, the program calculates the maximum shear stress in the faces at the gable line to determine if the design value is exceeded. If the faces are overstressed, the face thickness is increased and the shear stresses are recalculated (mode equals 7.0).

At this point, the program rounds up the thickness of the face and exterior insulation to a produced thickness. The program checks whether the correct thicknesses were used to calculate the dead weight of the panel. If not the program is returned to the point of initial dead weight computation, otherwise the program drops through and continues by calculating the panel cost, R value, and maximum deflection. If the ratio of core to face thickness has been exceeded, or the core stress has exceeded the critical design shear stress value the program exits to the output stage. If neither of these two criteria are violated, the program displays the solutions on the screen for the user's review. Next, the program compares the cost of this panel solution to the cost of the previous panel solution (initially set at the beginning of the program at a very high cost). If the present solution is cheaper than the previous solution then the values for the R value, cost, material thicknesses, and in the case of a folded plate, ridge and eave deflections are stored for final output as the optimal solution. Next the core thickness is reduced by an incremental amount and the program is returned to the the beginning of the algorithm where the dead weight of the panel is computed. The program continues decreasing the core thickness until either the ratio of core to face thickness or the design value for shear stress in the core is exceeded. What results from this section of the program is a screen display of possible panel solutions.

Following the list of panel solutions, the user is asked whether he/she would like to change the panel configuration. If the reply is yes, the data previously imputed by the user is displayed on the screen terminal with a number assigned to each data entry. The user enters the number of the data entry he/she would like to modify, followed by the corrected

data value. The program responds with the question, "Are there more changes to be made?" If no additional changes are desired, the program computes the panel solutions for the new panel configuration.

The user is asked whether a hard copy of the panel solutions is desired. If so, the data is sent to a file named *hard*. This file is backspaced internally within the program, making it possible to add additional panel configuration solutions to the output file. A hard copy of the file *hard* may be printed after exiting the program. Before the program can be executed, however, this file must be removed from the directory or an error message will be displayed.

The next section of the program can calculate the stresses and deflections in a sandwich panel folded plate roof. If the user decides to utilize this section, the face and core thickness of the panel, and, if employed, the area of the eave line member must be input interactively. The material properties, loads, and geometry are the same as originally input. The ridge and eave deflections are displayed on the screen. The user is then asked if he/she desires to examine stresses in a transverse section cut through the folded plate. If answered yes, the user is asked at what distance from the left gable line should the cut be made; how many points equally spaced along the transverse cut should the stresses be calculated at. The output displayed on the screen is coded as follows:

y = Transverse distance from the midspan of the folded plate roof (in.).

f_{sigly} = Stress in the face due to "one-way slab" action in the transverse direction (p.s.i.).

$f_{ctau_{lyz}}$ = Out-of-plane shear stress in the face and core due to
"one-way slab" action (p.s.i.).

f_{sigpx} = Stress in the face due to "plate" action in the longitudinal direction (p.s.i.).

c_{sigpx} = Stress in the core due to "plate" action in the longitudinal direction (p.s.i.).

f_{taupxy} = In-plane shear stress in the face due to "plate" action (p.s.i.).

τ_{plate} = In-plane shear stress in the core due to "plate" action (p.s.i.).

The folded plate stress analysis results in a biaxial stress condition which must be checked by a failure criteria which is dependent on the material properties. Following any number of repeated cuts, the program inquires whether the user would like to switch from a folded plate with no longitudinal line members to one with, or visa versa? If the switch is requested, the program is returned to point requesting the area of eave line member.

If the user would like to change from a panel with non-structural exterior insulation to one without, or vice versa, the program is returned to the beginning of the program where the user inputs data for the external insulation. Additionally, should the user desire to switch from a folded plate to a ridge beam system, or visa versa, the program is routed to the point of data entry for the folded plate. If both of these options are bypassed the user is asked whether he/she desires to exit the program. If the reply is no, the program is returned to where the user is questioned about changing the panel configuration. If the reply is yes, the program execution ends.

A.3 Panel.f Hard Copy

```
1 c2345678901234567890123456789012345678901234567890123456789012345678901234567890123456789012
2 implicit real(a-h,s-z), integer(i-r)
3 real l, mtf, mom, mtc, mrcf, rf, rc, ri, r, p, ip, rad, mp, pw, q
4 real pip, mode
5 integer ext2, page
6 character*1 fold, reanal, exit, switch, recut, cut, skip, copy
7 character*1 line
8 open(unit=1, file='hard', form='print', status='new')
9 c
10 c This program optimizes the design of a sandwich beam with
11 c respect to costs, for a given required R value, load, geometry,
12 c thermal or hygroscopic expansion, and deflection
13 c constraints. There are two design concepts for sandwich
14 c panel construction. Additionally, the program will analyze
15 c folded plate for deflections and stresses.
16 c
17 c print*, 'This program optimizes the design of a sandwich beam'
18 c print*, 'with respect to cost, for a given: required R value,'
19 c print*, 'load, geometry, thermal or hygroscopic expansion, and'
20 c print*, 'deflection constraints.'
21 c print*, ' '
22 c print*, ' '
23 c
24 c Give the user a choice of design concepts.
25 c
26 c print*, 'There are two possible design concepts for sandwich panel
27 c + construction.'
28 c print*, '1. Faces and an insulating, structural core.'
29 c print*, '2. Faces, structural core, and a non-structural'
30 c print*, ' insulation added to the exterior.'
31 c print*, 'Enter number of choice.'
32 c read*, ext2
33 c print*, ' '
34 c print*, ' '
35 c print*, 'Additionally, this program will analyze folded plate'
36 c print*, 'structures for stresses and deflections.'
37 c print*, ' '
38 c print*, ' '
39 c print*, 'Are you interested in folded plate design? (y/n)'
40 c read*, fold
41 c print*, ' '
42 c print*, ' '
43 c
44 c Set page number equal to 0
45 c
46 c page=0
47 c
48 c Set initial answer to hard copy request as 'no'
49 c
50 c copy='n'
51 c
52 c Input data.
53 c
54 c print*, 'Enter horizontal distance between eave lines (in.).'
55 c read*, b2
56 c print*, 'Enter slope of pitch of roof (i.e. 6, means a pitch of 6
57 c +to 12).'
58 c read*, p
59 c print*, 'Enter live load per horizontal projected area of roof (p.
60 c +s.f.).'
61 c read*, wli
62 c print*, 'Enter wind pressure normal to roof (p.s.f.).'
63 c read*, ww
64 c print*, 'Enter allowable displacement factor for panel bending (de
65 c +fl.=span/factor).'
66 c print*, 'live load only, dead and live load (i.e. 240.0, 180.0).'
```

```
67     read*, fl,fdl
68     print*, 'Enter difference in average temperature of the outer and
69 +inner face for:'
70     print*, 'maximum summer, appropriate winter, and maximum winter (de
71 +grees F)'
72     print*, '(i.e. 100,70,100).'
```



```
133     print*, 'Enter weight of core material (p.c.f.).'
134     read*, wcc
135     print*, 'Enter cost of structural adhesive per square foot ($.s.f.
136 +). '
137     read*, ca
138 20   if(ext2.eq.2)then
139         print*, 'Enter incremental production thickness of exterior'
140         print*, 'insulation material (in.).'
141         read*, dti
142         print*, 'Enter cost of exterior insulation material per board'
143         print*, 'foot ($.b.f.).'
144         read*, ci
145         print*, 'Enter R value per inch for exterior insulation'
146         print*, 'material.'
147         read*, ri
148         print*, 'Enter weight of exterior insulation material (p.c.f.).
149 + '
150         read*, wic
151         print*, 'Enter cost of non-structural adhesive per square'
152         print*, 'foot ($.s.f.).'
153         read*, cai
154     endif
155 c
156 c   If the program has been re-routed to line 20 by a request to
157 c   switch panel type at the end of the program, skip the data input
158 c   section on the folded plate.
159 c
160     if(switch.eq.'y')go to 100
161 30   if(fold.eq.'y')then
162         print*, 'Enter longitudinal length of span between gable lines
163 + (in.). '
164         read*, l
165         print*, 'Enter the width of the panel element (in.).'
166         read*, pw
167         print*, 'Enter the in-plane shear modulus of the face material
168 + (k.s.i.). '
169         read*, gf
170         print*, 'Enter design value for critical shear stress of the fac
171 + e material (k.s.i.). '
172         read*, yss
173         print*, 'Enter in-plane shear modulus of the core material (k.
174 + s.i.). '
175         read*, gcp
176         print*, ' '
177         print*, ' '
178         print*, 'Does the folded plate utilize longitudinal line member
179 + s? (y/n)'
180         read*, line
181         print*, ' '
182         print*, ' '
183         if(line.eq.'y')then
184             print*, 'Enter design value for critical tension or compressi
185 + on stress'
186             print*, 'of the longitudinal line material (k.s.i.).'
187             read*, ysl
188             print*, 'Enter youngs modulus of the eave line member (k.s.i
189 +.). '
190             read*, eavee
191         else
192             print*, 'Enter youngs modulus of the face material in longit
193 + udinal direction (k.s.i.).'
194             read*, ep
195             print*, 'Enter youngs modulus of the core material in longit
196 + udinal direction (k.s.i.).'
197             read*, ecp
198         endif
```

```
199     endif
200     print*, ' '
201     print*, ' '
202     c
203     c   Create headings for the panel solutions.
204     c
205     100  if(ext2.eq.1)then
206         if(copy.eq.'n')then
207             write(*,110)
208             write(*,120)
209             write(*,150)
210         endif
211     105  format('1')
212     106  format(' Page', i4)
213     110  format('  core      face      weight      R      defl.      cost
214 + fail.')
215     120  format(' (in.)      (in.)      (p.s.f.)      (in.)      ($s.f.)
216 + mode')
217         if(copy.eq.'y')then
218             page=page+1
219             write(1,105)
220             write(1,106)page
221             write(1,150)
222             write(1,110)
223             write(1,120)
224             write(1,150)
225         endif
226     else
227         if(copy.eq.'n')then
228             write(*,130)
229             write(*,140)
230             write(*,150)
231         endif
232     130  format('  core      face      ins.      weight      R      defl.      c
233 +ost      fail.')
234     140  format(' (in.)      (in.)      (in.)      (p.s.f.)      (in.)      (
235 +$.s.f.) mode')
236     150  format(' ')
237         if(copy.eq.'y')then
238             page=page+1
239             write(1,105)
240             write(1,106)page
241             write(1,150)
242             write(1,130)
243             write(1,140)
244             write(1,150)
245         endif
246     endif
247     c
248     c   Calculate the increased in young's modulus due
249     c   to wide beam action.
250     c
251     c   ef=e/(1.0-vf**2)
252     c
253     c   Calculate the ratio between the young's modulus of the core and
254     c   the face material for the longitudinal direction.
255     c
256     if(ep.eq.0.0)then
257         eratio=0.0
258     else
259         eratio=ecp/ep
260     endif
261     c
262     c   Calculate the ratio between in-plane shear modulus of the core and
263     c   the face material.
264     c
```

```
265     if(gf.eq.0.0)then
266         gratio=0.0
267     else
268         gratio=gcp/gf
269     endif
270 c
271 c     Calculate geometry of the roof.
272 c
273     pip=p/12.0
274     rad=atan(pip)
275     h=b2/(2.0*cos(rad))
276     d=h*sin(rad)
277 c
278 c     Calculate the allowable maximum deflection for live load.
279 c
280     adefl=h/fl
281 c
282 c     Calculate the allowable maximum deflection for live and dead load.
283 c
284     adefld=h/fdl
285 c
286 c     Set the first pass through at a very, very high cost.
287 c
288     ccost=10000000.
289 c
290 c     Set the core thickness to the maximum core depth.
291 c
292     tc=mtc
293 c
294 c     If user sets minimum thickness of face material to be zero,
295 c     increase it to a finite value.
296 c
297 200     if(mtf.eq.0.0)mtf=0.001
298 c
299 c     Set face thickness to the minimum face thickness.
300 c
301         tf=mtf
302 c
303 c     Set the mode failure initially equal to 1, or no mode failure.
304 c
305         mode=1.0
306 c
307 c     Store the value of the face thickness as a variable,
308 c     to determine if the true dead weight for the panel has been
309 c     used in calculating the face thickness.
310 c
311 250     tfdead=tf
312 c
313 c     Store the value of the exterior insulation thickness as a variable
314 c     to determine if the true dead weight for the panel has been
315 c     used in calculating the face thickness.
316 c
317         tidead=ti
318 c
319 c     Reduce the snow load if it is greater than 20 p.s.f.
320 c
321     if(wli.gt.20.0.and.rad.gt.0.3490659)then
322         wl=wli-(atan(real(p)/12.0)
323 +         *45.0/atan(1.0)-20.0)*(wli/40.0-0.5)
324     else
325         wl=wli
326     endif
327 c
328 c     Calculate the dead load of panel (p.s f.).
329 c
330     wd=tf*wfc/6.0+tc*wcc/12.0+ti*wic/12.0+wrs+wis
```

```
331 c
332 c Calculate the most critical total transverse load per unit
333 c width (lb./in.).
334 c
335     if(p.lt.9.0)then
336         cq=0.0
337     elseif(p.ge.9.0.and.p.le.12.0)then
338         cq=0.8
339     else
340         cq=1.1
341     endif
342     wsl=((cos(rad)*wl+wd)*cos(rad))/144.0
343     ws2=0.75*((cos(rad)*wl+wd)*cos(rad)+ww*cq/2.0)/144.0
344     ws3=0.75*((cos(rad)*wl/2.0+wd)*cos(rad)+ww*cq)/144.0
345     ws4=0.75*(ww*1.1-wd*cos(rad))/144.0
346     if(wsl.gt.ws2.and.wsl.gt.ws3.and.wsl.gt.ws4)then
347         ws=wsl
348     elseif(ws2.gt.ws3.and.ws2.gt.ws4)then
349         ws=ws2
350     elseif(ws3.gt.ws4)then
351         ws=ws3
352     else
353         ws=ws4
354     endif
355 c
356 c Calculate face thickness from both live load deflection
357 c constraints, and dead and live load deflection constraints,
358 c including, controlling live load, creep factor, and appropriate
359 c winter temperature differences. If the face thickness needs
360 c to be increased, set themode equal to 2.1 or 2.2,
361 c the stiffness constraint.
362 c
363     300     ei=ef/creepf*tf**3/6.0+ef/creepf*tf*(tc+tf)**2/2.0+
364     +tec/creepc*tc**3/12.0
365     if(p.lt.9.0)then
366         cq=0.0
367     elseif(p.ge.9.0.and.p.le.12.0)then
368         cq=0.8
369     else
370         cq=1.1
371     endif
372     wlc1=wl+cq*ww/(2.0*cos(rad)**2)
373     wlc2=wl/2.0+cq*ww/cos(rad)**2
374     if(wlc1.gt.wlc2)then
375         wlc=wlc1
376     else
377         wlc=wlc2
378     endif
379     defl=(5*h**4/(384.0*ei*1000.0)+
380 +h**2*tc/(8.0*(tc+tf)**2*gc/creepc*1000.0))*cos(rad)**2*wlc/144.0+
381 +tempaw*0.000001*fcoeff*h**2/(8.0*(tc+tf))
382     defld=(5*h**4/(384.0*ei*1000.0)+
383 +h**2*tc/(8.0*(tc+tf)**2*gc/creepc*1000.0))*(cos(rad))**2*
384 +(wlc+wd/cos(rad))/144.0+
385 +tempaw*0.000001*fcoeff*h**2/(8.0*(tc+tf))
386     if(defl.gt.adefl)then
387         mode=2.1
388         tf=tf+dtf
389         go to 300
390     endif
391     if(defld.gt.adefld)then
392         mode=2.2
393         tf=tf+dtf
394         go to 300
395     endif
396     deflm=0.0
```

```
397         if(defld.gt.defl)then
398             deflm=defld
399         else
400             deflm=defl
401         endif
402     c
403     c     Calculate face thickness from live and dead load deflection
404     c     constraint, including outward wind pressure, maximum summer
405     c     temperature differences or hygroscopic gradient, and dead load.
406     c     If the face thickness needs to be increased, set the
407     c     mode equal to 2.3 or 2.4, the stiffness constraint.
408     c
409         cq=1.1
410     310     ei=ef*tf**3/6.0+ef*tf*(tc+tf)**2/2.0+
411         +ec*tc**3/12.0
412             defld1=(5*h**4/(384.0*ei*1000.0)+
413             +h**2*tc/(8.0*(tc+tf)**2*gc*1000.0))*(-cos(rad)*wd+ww*cq)/144.0+
414             +temps*0.000001*fcoeff*h**2/(8.0*(tc+tf))
415             defld2=(5*h**4/(384.0*ei*1000.0)+
416             +h**2*tc/(8.0*(tc+tf)**2*gc*1000.0))*(-cos(rad)*wd+ww*cq)/144.0+
417             +fhygro*h**2/(8.0*(tc+tf))
418             if(defld1.gt.adefld)then
419                 mode=2.3
420                 tf=tf+dtf
421                 go to 310
422             endif
421         go to 310
422     endif
423     if(defld2.gt.adefld)then
424         mode=2.4
425         tf=tf+dtf
426         go to 310
427     endif
428     if(defld1.gt.deflm)then
429         deflm=defld1
430     elseif(defld2.gt.deflm)then
431         deflm=defld2
432     endif
433     c
434     c     Calculate face thickness from live and dead deflection
435     c     constraints, including inward wind pressure, maximum winter
436     c     temperature differences, and dead load.
437     c     If the face thickness needs to be increased, set the
438     c     mode equal to 2.5, the stiffness constraint.
439     c
440         if(p.lt.9.0)cq=0.0
441         if(p.ge.9.0.and.p.le.12.0)cq=0.8
442         if(p.gt.12.0)cq=1.1
443     320     defld=(5*h**4/(384.0*ei*1000.0)+
444         +h**2*tc/(8.0*(tc+tf)**2*gc*1000.0))*(cos(rad)*wd+ww*cq)/144.0+
445         +temps*0.000001*fcoeff*h**2/(8.0*(tc+tf))
446         if(defld.gt.adefld)then
447             mode=2.5
448             tf=tf+dtf
449             go to 320
450         endif
451         if(defld.gt.deflm)deflm=defld
452     c
453     c     Calculate face thickness based on face yielding
454     c
455     350     ei=(ef*tf**3/6.0)+(ef*tf*(tf+tc)**2/2.0)+(ec*tc**3)/(12.0)
456         fsigly=((ws*(tc+2.0*tf)*ef*h**2))/(16.0*ei*1000.0)
457         if(fsigly.gt.ysf)then
458             mode=3.0
459             tf=tf+dtf
460             go to 350
461         endif
```

```
463 c Calculate face thickness based on face wrinkling.
464 c
465 c     bl=0.5
466 c     wfs=(b1*((ef*1000.0*eco*1000.0*gc*1000.0)**(1.0/3.0)))
467 c     c=-mom/wfs
468 c     call quad(1.0, tc, c, tfw)
469 c
470 c If face thickness required to prevent face wrinkling is larger
471 c than that required from other constraints, set face thickness
472 c equal to the face wrinkling thickness.
473 c
474 c     if(tfw.gt.tf)then
475 c         tf=tfw
476 c         mode=4.0
477 c     endif
478 c
479 c Calculate thickness of face to satisfy insulation constraints,
480 c only if there is no exterior insulation.
481 c
482 c     if(ext2.eq.1)then
483 c         cr=tc*rc
484 c         If(cr.ge.r)cr=r
485 c         tfi=(r-cr)/(2.0*rf)
486 c
487 c If face thickness required for insulation needs is larger than
488 c that required by other constraints, set the face thickness equal
489 c to the face thickness determined by insulation needs.
490 c
491 c     if(tfi.gt.tf)then
492 c         tf=tfi
493 c         mode=5.0
494 c     endif
495 c endif
496 c
497 c If one is designing for a folded plate, check whether the face
498 c thickness meets the folded plate deflections.
499 c Skip this section if one is not concerned with folded plate.
500 c
501 c     if(fold.eq.'y')then
502 c
503 c Set skip equal to 'n' to prevent an exit from program, which
504 c occurs if previously sent to line 400 by plate stresses and
505 c deflections section.
506 c
507 c         skip='n'
508 c
509 c Calculate allowable deflections at ridge and eave.
510 c
511 c         fv=1/240.0
512 c         fh=1/240.0
513 c
514 c Calculate in-plane load, and moment.
515 c
516 c 400         wp=((cos(rad)*wl)/144.0+wd/144.0)*h/(2.0*sin(rad))
517 c         mp=(wp*l**2)/8.0
518 c
519 c Calculate the area of the eave line member based on strength,
520 c only if not referred from folded plate stress and deflection
521 c section, where the eave line member area is inputed
522 c (skip equals 'n'), and only if longitudinal line members are used.
523 c
524 c         if(skip.eq.'n'.and.line.eq.'y')eavea=
525 c +wp*l**2/(8.0*ysl*1000.0*h)
526 c         if(line.eq.'n')then
527 c
528 c Calculate plate deflections with no longitudinal line member.
```



```
595 c
596     if(dh.gt.fh.or.dv.gt.fv)then
597         mode=6.0
598         trr=tf/dtf
599         tr=trr-int(trr)
600         if(tf.gt.mtf.and.tr.gt.0.0)then
601             tf=int(trr)+2*dtf
602             go to 400
603         elseif(tf.gt.mtf.and.tr.eq.0.0)then
604             tf=tf+dtf
605             go to 400
606         elseif(tf.eq.mtf)then
607             tf=mtf+dtf
608             go to 400
609         endif
610     endif
611 c
612 c     If the maximum shear stress in the face at the gable line
613 c     is exceeded, increase face thickness.
614 c
615     430     ap=(tf*2.0+gratio*tc)*h
616     if(line.eq.'n')then
617         ss=3.0*wp*1/(4.0*ap*1000.0)
618     else
619         ss=wp*1/(2.0*ap*1000.0)
620     endif
621     if(ss.gt.yss)then
622         mode=7.0
623         trr=tf/dtf
624         tr=trr-int(trr)
625         if(tf.gt.mtf.and.tr.gt.0.0)then
626             tf=int(trr)+2*dtf
627             go to 430
628         elseif(tf.gt.mtf.and.tr.eq.0.0)then
629             tf=tf+dtf
630             go to 430
631         elseif(tf.eq.mtf)then
632             tf=mtf+dtf
633             go to 430
634         endif
635     endif
636     endif
637 c
638 c     Round face thickness up to a thickness produced.
639 c
640     trr=tf/dtf
641     tr=ttr-int(trr)
642     if(tf.gt.mtf.and.tr.gt.0.0)then
643         itf=tf/dtf
644         tf=(itf+1)*dtf
645     endif
646 c
647 c     Calculate thickness of exterior insulation to satisfy insulation
648 c     requirements, only if exterior insulation is added to the panel.
649 c
650     if(ext2.eq.2)then
651         ctr=tc*rc+tf*rf*2.0
652         if(ctr.ge.r)ctr=r
653         ti=(r-ctr)/ri
654 c
655 c     Round exterior insulation thickness up to a thickness produced
656 c
657     if(ti.gt.dti)then
658         iti=ti/dti
659         ti=(iti+1)*dti
660     elseif(ti.lt.dti.and.ti.gt.0.0)then
```



```
661             ti=dti
662         endif
663     endif
664 c
665 c     If the correct face thickness has been used to calculate the
666 c     dead weight of the panel continue.  If not, recalculate the dead
667 c     dead weight of the panel and the face thickness.
668 c
669 c         if(tf.gt.tfdead)go to 250
670 c
671 c     If the correct exterior insulation thickness has been used to
672 c     calculate the dead weight of the panel, continue.  If not,
673 c     recalculate the dead weight of the panel and the face thickness.
674 c
675 c         if(ti.gt.tidead)go to 250
676 c
677 c     Calculate cost of panel.
678 c
679 c         scost=2.0*cf*tf+cc*tc+ci*ti+2.0*ca+cai
680 c
681 c     Calculate the R value of the panel.
682 c
683 c         valuer=2.0*tf*rf+tc*rc+ti*ri
684 c
685 c     Check if faces are exceptionally thick compared to core.
686 c     Analysis becomes inaccurate, and the panel too heavy.
687 c
688 c         arcf=tc/tf
689 c         if(arcf.lt.mrcf)go to 600
690 c
691 c     Check if there is core yielding.
692 c
693 c         q=(ws*h)/(2.0*(tc+tf)*1000.0)
694 c         if(q.gt.ysc)go to 600
695 c
696 c     Print out various panel solutions.
697 c
698 470     if(ext2.eq.1)then
699         if(copy.eq.'n')write(*,500)tc, tf, wd, valuer, deflm, scost,
700 +mode
701 500     format(' ', 6g9.3, 1x, f3.1)
702         if(copy.eq.'y')then
703             write(1,500)tc, tf, wd, valuer, deflm, scost, mode
704         endif
705     else
706         if(copy.eq.'n')write(*,510) tc, tf, ti, wd, valuer, deflm, s
707 +cost, mode
708 510     format(' ', 7g9.3, 1x, f3.1)
709         if(copy.eq.'y')then
710             write(1,510)tc, tf, ti, wd, valuer, deflm, scost, mode
711         endif
712     endif
713 c
714 c     See which is cheapest.
715 c
716 c         if(scost.lt.ccost)then
717             fvaluer=valuer
718             ccost=scost
719             ftf=tf
720             ftc=tc
721             fti=ti
722             fwd=wd
723             fdv=dv
724             fdh=dh
725         endif
726         tc=tc-dtc
```

```
727         go to 200
728 c
729 c   Display output on screen.
730 c
731 600 if(copy.eq.'n')then
732     print*, '1=No constraint  2.1-.5=Stiffness  3=Face yielding  4=Fac
733 +e wrinkling'
734     print*, '5=R value requirements  6=Folded plate deflections  7=Folded
735 +e plate shear'
736     print*, ' '
737     print*, 'The final thickness of the core is', ftc, '(in.).'
738     print*, 'The final thickness of the face is', ftf, '(in.).'
739     if(ext2.eq.2)then
740         print*, 'The final thickness of the exterior'
741         print*, '        non-structural insulation is', fti, '(in.).'
742     endif
743     print*, 'The final weight of the panel is', fwd, '(p.s.f.).'
744     print*, 'The final R value of the panel is', fvaluer
745     print*, 'The final cost of the panel is ', ccost, '($.s.f.).'
746     print*, ' '
747     if(fold.eq.'y')then
748         print*, 'Allowable vertical ridge deflection is', fv, '(in.).'
749         print*, 'The final vertical ridge deflection is', fdv, '(in.).'
750         print*, 'Allowable horizontal eave deflection is', fh, '(in.).'
751         print*, 'The final horizontal eave deflection is', fdh, '(in.).'
752     +.
753         print*, ' '
754     endif
755     endif
756 c
757 c   Send data to a hard copy file if requested.
758 c
759     if(copy.eq.'y')then
760         write(1,*)' '
761         write(1,*)' '
762         write(1,*)' 1=No constraint  2.1-.5=Stiffness  3=Face yielding  4=
763 +Face wrinkling'
764         write(1,*)' 5=R value requirements  6=Folded plate deflections  7=
765 +Folded plate shear'
766         write(1,*)' '
767         write(1,*)' '
768         write(1,*)' '
769         write(1,*)' The final thickness of the core is', ftc, '(in.).'
770         write(1,*)' The final thickness of the face is', ftf, '(in.).'
771         if(ext2.eq.2)then
772             write(1,*)' The final thickness of the exterior'
773             write(1,*)'        non-structural insulation is', fti, '(in.).'
774         endif
775         write(1,*)' The final weight of the panel is', fwd, '(p.s.f.).'
776         write(1,*)' The final R value of the panel is', fvaluer
777         write(1,*)' The final cost of the panel is ', ccost, '($.s.f.).'
778         write(1,*)' '
779         if(fold.eq.'y')then
780             write(1,*)' Allowable vertical ridge deflection is', fv, '(in.)
781 +.
782             write(1,*)' Final vertical ridge deflection is', fdv, '(in.).'
783             write(1,*)' Allowable horizontal eave deflection is', fh, '(in.
784 +).
785             write(1,*)' Final horizontal eave deflection is', fdh, '(in.).'
786             write(1,*)' '
787         endif
788     endif
789 c
790 c   Set the answer for the copy question equal to no, after all
791 c   copying to hard file has been completed.
792 c
```

```
793     copy='n'
794 700  print*, 'Would you like to change panel configuration'
795     print*, 'and reanalyze? (y/n)'
796     read*, reanal
797     if(reanal.eq.'n')go to 1000
798 750  print*, ' 1. = Horizontal distance between eave lines = ', b2, '(i
799     +n.)'
800     print*, ' 2. = Slope of pitch of roof = ', p
801     print*, ' 3. = Live load per horizontal projected area of roof = '
802     +, wli, '(p.s.f.)'
803     print*, ' 4. = Wind pressure normal to roof = ', ww, '(p.s.f.)'
804     print*, ' 5. = Allowable displacement factor for panel bending:'
805     print*, '     live load only, dead and live load = ', fl, fdl, 'r
806     +respectively.'
807     print*, ' 6. = Difference in average temperature of the outer and
808     +inner face for:'
809     print*, '     maximum summer, appropriate winter, and maximum wint
810     +er = (degrees F)'
811     print*, '     ', temps, tempaw, tempw, ' respectively.'
812     print*, ' 7. = Require R value for roof panel = ', r
813     print*, ' 8. = Maxium depth to be considered for the core = ', mtc
814     +, '(in.)'
815     print*, ' 9. = Minimum ratio of thickness of core to thickness of
816     + face to be'
817     print*, '     considered = ', mrcf
818     print*, '10. = Weight of roofing material = ', wrs, '(p.s.f.)'
819     print*, '11. = Weight of interior finish material = ', wis, '(p.s.f
820     +.)'
821     print*, '12. = Youngs modulus of the face material in transverse d
822     +irection. (k.s.i.)'
823     print*, '     and a creep factor (-) = ', e, creepf, ' respectivel
824     +y.'
825     print*, '13. = Thermal coefficient of expansion (x10-06 strain/deg
826     +ree F.)'
827     print*, '     and the hygroscopic strain gradient (-) of the face
828     + material = '
829     print*, '     ', fcoeff, fhygro, 'respectively.'
830     print*, '14. = Poisson ratio for the face material = ', vf
831     print*, '15. = Design value for the critical flexural stress of th
832     +e face material = '
833     print*, '     ', ysf, '(k.s.i.)'
834     print*, '16. = Minimum thickness of face material = ', mtf, '(in.)
835     +'
836     print*, '17. = Incremental production thickness of face material =
837     + ', dtf, '(in.)'
838     print*, '18. = Cost per board foot of face material = ', cf, '($.b
839     +f.)'
840     print*, '19. = R value per inch for the face material = ', rf
841     print*, '20. = Weight of face material = ', wfc, '(p.c.f.)'
842     print*, '21. = Youngs modulus of the core material in transverse d
843     +irection = '
844     print*, '     ', ec, '(k.s.i.)'
845     print*, '22. = Youngs modulus of the core material in out-of-plane
846     + direction = '
847     print*, '     ', eco, '(k.s.i.)'
848     print*, '23. = Out-of-plane shear modulus of the core material (k.
849     +s.i.), and'
850     print*, '     a creep factor (-) = ', gc, creepc, ' respectively.
851     +'
852     print*, '24. = Poisson ratio for the core material = ', vc
853     print*, '25. = Design value for the critical shear stress of the
854     +core material = '
855     print*, '     ', ysc, '(k.s.i.)'
856     print*, '26. = Incremental production thickness of core material
857     += ', dtc, '(in.)'
858     print*, '27. = Cost of core material per board foot = ', cc, '($.b
```

```
859 +f.)'
860 print*, '28. = R value per inch for the core material = ', rc
861 print*, '29. = Weight of core material = ', wcc, '(p.c.f.)'
862 print*, '30. = Cost of structural adhesive per square foot = ', ca
863 +, '($.s.f.)'
864 if(ext2.eq.2)then
865     print*, '31. = Incremental production thickness of exterior ins
866 +ulation material = '
867     print*, ' ', dti, '(in.)'
868     print*, '32. = Cost of exterior insulation material per board f
869 +oot = '
870     print*, ' ', ci, '($.b.f.)'
871     print*, '33. = R value per inch for exterior insulation materia
872 +l = ', ri
873     print*, '34. = Weight of exterior insulation material = ', wic,
874 + '(p.c.f.)'
875     print*, '35. = Cost of non-structural adhesive per square foot
876 += ', cai, '($.s.f.)'
877 endif
878 if(fold.eq.'y')then
879     print*, '36. = Longitudinal length of span between gable lines
880 += ', l, '(in.)'
881     print*, '37. = Width of the panel element = ', pw, '(in.)'
882     print*, '38. = In-plane shear modulus of the face material = ',
883 +gf, '(k.s.i.)'
884     print*, '39. = Design value for critical shear stress of the fac
885 +e material = ', yss, '(k.s.i.)'
886     print*, '40. = In-plane shear modulus of the core material = ',
887 +gcp, '(k.s.i.)'
888     if(line.eq.'y')then
889         print*, '41. = Design value for critical tension or compressi
890 +on stress of the'
891         print*, ' ', ysl, '(k.s.i.)'
892     +
893         print*, '42. = Youngs modulus of the eave line member = ', e
894 +avee, '(k.s.i.)'
895     else
896         print*, '43. = Youngs modulus of the face material in longit
897 +udinal direction = ', ep, '(k.s.i.)'
898         print*, '44. = Youngs modulus of the core material in longit
899 +udinal direction = ', ecp, '(k.s.i.)'
900     endif
901 endif
902 print*, ' '
903 print*, 'Enter number of desired change.'
904 read*, k
905 if(k.eq.1)then
906     print*, 'Enter horizontal distance between eave lines (in.)'
907     read*, b2
908 elseif(k.eq.2)then
909     print*, 'Enter slope of pitch of roof (i.e. 6, means a pitch of 6
910 +to 12).'
911     read*, p
912 elseif(k.eq.3)then
913     print*, 'Enter live load per horizontal projected area of roof (p.
914 +s.f.)'
915     read*, wli
916 elseif(k.eq.4)then
917     print*, 'Enter wind pressure normal to roof (p.s.f.)'
918     read*, ww
919 elseif(k.eq.5)then
920     print*, 'Enter allowable displacement factor for panel bending (de
921 +fl.=span/factor)'
922     print*, 'live load only, dead and live load (i.e. 240.0, 180.0)'
923     read*, fl,fdl
924     elseif(k.eq.6)then
```

```
925     print*, 'Enter difference in average temperature of the outer and
926 +inner face for:'
927     print*, 'maximum summer, appropriate winter, and maximum winter (de
928 +grees F) (i.e. 100,70,100).'
```

929 read*, temps, tempaw, tempw

930 elseif(k.eq.7)then

931 print*, 'Enter require R value for roof panel'

932 read*, r

933 elseif(k.eq.8)then

934 print*, 'Enter maxium depth to be considered for the core (in.)'

935 read*, mtc

936 elseif(k.eq.9)then

937 print*, 'Enter minimum ratio of thickness of core to '

938 print*, 'thickness of face to be considered.'

939 print*, 'A ratio of 5 is recommended.'

940 read*, mrcf

941 elseif(k.eq.10)then

942 print*, 'Enter weight of roofing material (psf)'

943 read*, wrs

944 elseif(k.eq.11)then

945 print*, 'Enter weight of interior finish material (psf)'

946 read*, wis

947 elseif(k.eq.12)then

948 print*, 'Enter youngs modulus of the face material in transverse d

949 +irection (k.s.i.).'

950 print*, 'and a creep factor based on a transient live load (-).'

951 read*, e, creepf

952 elseif(k.eq.13)then

953 print*, 'Enter thermal coefficient of expansion (x10-06 strain/deg

954 +ree F.).'

955 print*, 'and the hygroscopic strain gradient (-) of the face mater

956 +ial.'

957 read*, fcoeff, fhygro

958 elseif(k.eq.14)then

959 print*, 'Enter poisson ratio for the face material'

960 read*, vf

961 elseif(k.eq.15)then

962 print*, 'Enter design value for the critical flexural stress of th

963 +e face material (ksi)'

964 read*, ysf

965 elseif(k.eq.16)then

966 print*, 'Enter minimum thickness of face material (in.)'

967 read*, mtf

968 elseif(k.eq.17)then

969 print*, 'Enter incremental production thickness '

970 print*, 'of face material (in.)'

971 read*, dtf

972 elseif(k.eq.18)then

973 print*, 'Enter cost per board foot of face material (\$.s.f.)'

974 read*, cf

975 elseif(k.eq.19)then

976 print*, 'Enter R value per inch for the face material'

977 read*, rf

978 elseif(k.eq.20)then

979 print*, 'Enter weight of face material (pcf)'

980 read*, wfc

981 elseif(k.eq.21)then

982 print*, 'Enter youngs modulus of the core material in the transver

983 +se direction (ksi)'

984 read*, ec

985 elseif(k.eq.22)then

986 print*, 'Enter youngs modulus of the core material in out-of-plane

987 + direction (ksi)'

988 read*, eco

989 elseif(k.eq.23)then

990 print*, 'Enter out-of-plane shear modulus of the core material (k

```
991 +.s.i.).'  
992 print*, 'and a creep factor based on a transient live load (-).'  
993 read*, gc, creepc  
994 elseif(k.eq.24)then  
995 print*, 'Enter poisson ratio for the core material'  
996 read*, vc  
997 elseif(k.eq.25)then  
998 print*, 'Enter design value for the critical stress of the core ma  
999 +terial (ksi)'  
1000 read*, ysc  
1001 elseif(k.eq.26)then  
1002 print*, 'Enter incremental production thickness '  
1003 print*, 'of core material (in.)'  
1004 read*, dtc  
1005 elseif(k.eq.27)then  
1006 print*, 'Enter cost of core material per board foot ($)'  
1007 read*, cc  
1008 elseif(k.eq.28)then  
1009 print*, 'Enter R value per inch for the core material'  
1010 read*, rc  
1011 elseif(k.eq.29)then  
1012 print*, 'Enter weight of core material (pcf)'  
1013 read*, wcc  
1014 elseif(k.eq.30)then  
1015 print*, 'Enter cost of structural adhesive per square foot ($)'  
1016 read*, ca  
1017 elseif(k.eq.31)then  
1018 print*, 'Enter incremental production thickness of exterior'  
1019 print*, 'insulation material (in.).'  
1020 read*, dti  
1021 elseif(k.eq.32)then  
1022 print*, 'Enter cost of exterior insulation material per board'  
1023 print*, 'foot ($s.f.).'  
1024 read*, ci  
1025 elseif(k.eq.33)then  
1026 print*, 'Enter R value per inch for exterior insulation'  
1027 print*, 'material.'  
1028 read*, ri  
1029 elseif(k.eq.34)then  
1030 print*, 'Enter weight of exterior insulation material (pcf)'  
1031 read*, wic  
1032 elseif(k.eq.35)then  
1033 print*, 'Enter cost of non-structural adhesive per square'  
1034 print*, 'foot ($s.f.).'  
1035 read*, cai  
1036 elseif(k.eq.36)then  
1037 print*, 'Enter longitudinal length of span between gable lines (in  
1038 +.).'  
1039 read*, l  
1040 elseif(k.eq.37)then  
1041 print*, 'Enter the width of the panel element (in.)'  
1042 read*, pw  
1043 elseif(k.eq.38)then  
1044 print*, 'Enter the in-plane shear modulus of the face material (ks  
1045 +i)'  
1046 read*, gf  
1047 elseif(k.eq.39)then  
1048 print*, 'Enter design value for critical shear stress of the face m  
1049 +aterial ((k.s.i.).'  
1050 read*, yss  
1051 elseif(k.eq.40)then  
1052 print*, 'Enter in-plane shear modulus of the core material (ksi)'  
1053 read*, gcp  
1054 elseif(k.eq.41)then  
1055 print*, 'Enter design value for critical tension or compressi  
1056 +on stress'
```

```
1057     print*, 'of the longitudinal line material (k.s.i.).'  
1058     read*, ysl  
1059     elseif(k.eq.42)then  
1060     print*, 'Enter youngs modulus of the eave line member (k.s.i  
1061     +.).'  
1062     read*, eavee  
1063     elseif(k.eq.43)then  
1064     print*, 'Enter youngs modulus of the face material in longitudinal  
1065     + direction (ksi)'  
1066     read*, ep  
1067     elseif(k.eq.44)then  
1068     print*, 'Enter youngs modulus of the core material in the longitud  
1069     +inal direction (ksi)'  
1070     read*, ecp  
1071     endif  
1072     print*, ' '  
1073     print*, 'Are there more changes to be made? (y/n)'  
1074     read*, reanal  
1075     if(reanal.eq.'y')go to 750  
1076     copy='no'  
1077     go to 100  
1078     c  
1079     c     Send data to an output file called hard  
1080     c  
1081     1000 print*, 'Would you like the resulting data sent to'  
1082     print*, 'a hard copy file (named hard)? (y/n)'  
1083     read*, copy  
1084     if(copy.eq.'y')then  
1085     c  
1086     c     Backspace the output file so that more data may be added.  
1087     c  
1088     backspace(unit=1)  
1089     page=page+1  
1090     write(1,105)  
1091     write(1,106)page  
1092     write(1,150)  
1093     write(1,*)' Horizontal distance between eave lines=', b2, '(in.)'  
1094     write(1,*)' Slope of pitch of roof (i.e. 6, means a pitch of 6 to  
1095     +12)=' , p  
1096     write(1,*)' Live load per horizontal projected area of roof=', wli  
1097     +, '(p.s.f.)'  
1098     write(1,*)' Wind pressure normal to roof=', ww, '(p.s.f.)'  
1099     write(1,*)' Allowable displacement factor for panel bending (i.e.  
1100     +defl=span/factor)'  
1101     write(1,*)' live load only, dead and live load=', fl, fdl  
1102     write(1,*)' Difference in average temperature of the outer and inn  
1103     +ter face for:'  
1104     write(1,*)' maximum summer, appropriate winter, and maximum winter=  
1105     +'  
1106     write(1,*) temps, tempaw, tempw, '(degrees F) respectively'  
1107     write(1,*)' Require R value for roof panel=', r  
1108     write(1,*)' Maxium depth to be considered for the core=', mtc, '(i  
1109     +n.)'  
1110     write(1,*)' Minimum ratio of thickness of core to thickness of fac  
1111     +e to be'  
1112     write(1,*)' considered=', mrcf  
1113     write(1,*)' Weight of roofing material=', wrs, '(p.s.f.)'  
1114     write(1,*)' Weight of interior finish material=', wis, '(p.s.f.)'  
1115     write(1,*)' '  
1116     write(1,*)' Youngs modulus of the face material in transverse dire  
1117     +ction (k.s.i.)'  
1118     write(1,*)' and a creep factor based on a transient live load (-)=  
1119     +'  
1120     write(1,*) e, creepf  
1121     write(1,*)' Thermal coefficient of expansion (x10-06 strain/degree  
1122     +F.), and'
```

```
1123     write(1,*)' the hygroscopic strain gradient (-) of the face materi
1124 +al=', fcoeff, fhygro
1125     write(1,*)' Poisson ratio for the face material=', vf
1126     write(1,*)' Design value for the critical flexural stress of the f
1127 +ace material=', ysf, ' (k.s.i.)'
1128     write(1,*)' Minimum thickness of face material=', mtf, '(in.)'
1129     write(1,*)' Incremental production thickness of face material=', d
1130 +tf, '(in.)'
1131     write(1,*)' Cost per board foot of face material=', cf, '($.b.f.)'
1132     write(1,*)' R value per inch for the face material=', rf
1133     write(1,*)' Weight of face material=', wfc, '(p.c.f.)'
1134     write(1,*)'
1135     write(1,*)' Youngs modulus of the core material in transverse dire
1136 +ction=', ec, ' (k.s.i.)'
1137     write(1,*)' Youngs modulus of the core material in out-of-plane di
1138 +rection=', eco, ' (k.s.i.)'
1139     write(1,*)' Out-of-plane shear modulus of the core material (k.s.i
1140 +.)'
1141     write(1,*)' and a creep factor based on a transient live load (-)=
1142 +
1143     write(1,*) gc, creepc
1144     write(1,*)' Poisson ratio for the core material=', vc
1145     write(1,*)' Design value for the critical shear stress of the core
1146 + material=', ysc, ' (k.s.i.)'
1147     write(1,*)' Incremental production thickness of core material=', d
1148 +tc, '(in.)'
1149     write(1,*)' Cost of core material per board foot=', cc, '($.b.f.)'
1150     write(1,*)' R value per inch for the core material=', rc
1151     write(1,*)' Weight of core material=', wcc, '(p.c.f.)'
1152     write(1,*)' Cost of structural adhesive per square foot=', ca, '($
1153 +.s.f.)'
1154     write(1,*)'
1155     if(ext2.eq.2)then
1156         write(1,*)' Incremental production thickness of exterior insula
1157 +tion material=', dti, '(in.)'
1158         write(1,*)' Cost of exterior insulation material per board foot
1159 +=', ci, '($.b.f.)'
1160         write(1,*)' R value per inch for exterior insulation material='
1161 +, ri
1162         write(1,*)' Weight of exterior insulation material=', wic, '(p.
1163 +c.f.)'
1164         write(1,*)' Cost of non-structural adhesive per square foot=',
1165 +cai, '($.s.f.)'
1166         write(1,*)'
1167     endif
1168     if(fold.eq.'y')then
1169         write(1,*)' Longitudinal length of span between gable lines=',
1170 + l, '(in.)'
1171         write(1,*)' Width of the panel element=', pw, '(in.)'
1172         write(1,*)' In-plane shear modulus of the face material=', gf,
1173 + '(k.s.i.)'
1174         write(1,*)' Design value for critical shear stress of the face m
1175 +aterial=', yss, ' (k.s.i.)'
1176         write(1,*)' In-plane shear modulus of the core material=', gcp,
1177 + '(k.s.i.)'
1178         if(line.eq.'y')then
1179             write(1,*)' Design value for critical tension or compressi
1180 +on stress of the'
1181             write(1,*)' longitudinal line material=', ysl, '(k.s.i.)'
1182             write(1,*)' Youngs modulus of the eave line member=', eavee,
1183 + '(k.s.i.)'
1184             write(1,*)' Area of the eave line member=', eavea, '(in.**2).
1185 +
1186         else
1187             write(1,*)' Youngs modulus of the face material in longitudi
1188 +nal direction=', ep, ' (k.s.i.)'
```



```
1189         write(1,*)' Youngs modulus of the core material in longitudi
1190 +nal direction=', ecp, ' (k.s.i.)'
1191     endif
1192     endif
1193     write(1,*)' '
1194     write(1,*)' Slope distance between eave and ridge=', h, '(in.)'
1195     write(1,*)' Allowable maximum deflection for the live load; liv
1196 +e and dead load'
1197     write(1,*)' acting on the horizontal projected area of roof (in.)=
1198 +', adefl, adefld
1199     go to 100
1200 1050 endif
1201 c
1202 c     This section of the program calculates stresses and deflections
1203 c     for a folded plate.
1204 c
1205     if(fold.eq.'y')then
1206         print*, 'This section of the program calculates stresses'
1207         print*, 'and deflections for a folded plate.'
1208         print*, 'The material properties and geometry are the same as'
1209         print*, 'above, but the material thicknesses must be inputed.'
1210         print*, ' '
1211         print*, 'Would you like to look at stresses and deflections? (y
1212 +/n)'
1213         read*, skip
1214         if(skip.eq.'n')go to 1470
1215         print*, ' '
1216         Print*, 'Enter thickness of the faces (in.)'
1217         read*, tf
1218         print*, ' '
1219         print*, 'Enter thickness of the core material (in.)'
1220         read*, tc
1221         print*, ' '
1222 c
1223 c     Calculate the dead load of panel.
1224 c
1225         wd=tf*wfc/6.0+tc*wcc/12.0+ti*wic/12.0+wrs+wis
1226 c
1227 c     Calculate in-plane load, and moment.
1228 c
1229         wp=((cos(rad)*wl)/144.0+wd/144.0)*h/(2.0*sin(rad))
1230         mp=(wp*l**2)/8.0
1231 c
1232 c     Calculate teh transverse load.
1233 c
1234         ws=((cos(rad)*wl+wd)*cos(rad))/144.0
1235 c
1236 c     Calculate the area of the eave line member based on strength.
1237 c
1238 1060     if(line.eq.'y')then
1239         eavea=wp*l**2/(8.0*ysl*1000.0*h)
1240         print*, 'Enter area of the eave line member (in.**2).'
1241         print*, 'Minimum area of eave line member calculated from st
1242 +rength requirements of'
1243         print*, 'plate action is,', eavea, '(in.**2).'
1244         read*, eavea
1245         print*, ' '
1246     endif
1247 c
1248 c     Go to plate deflection section at line 400. Program returned
1249 c     to line 1100 if skip equals 'y'.
1250 c
1251     go to 400
1252 1100     print*, 'Allowable vertical ridge deflection is', fv, '(in.)'
1253         print*, 'Vertical ridge deflection is', dv, '(in.)'
1254         print*, 'Allowable horizontal eave deflection is', fh, '(in.)'
```

```
1255     print*, 'Horizontal eave deflection is', dh, '(in.)'
1256     print*, ' '
1257     print*, 'Would you like to examine the stresses in a '
1258     print*, 'transverse cut through the folded plate? (y/n)'
1259     read*, cut
1260     if(cut.eq.'n')go to 1500
1261 1300     print*, 'At what distance from the left gable line do you want'
1262     print*, 'to examine stresses in a transverse section?'
1263     Print*, 'The length of span between gables is,', l, '(in.)'
1264     read*, xl
1265     print*, 'At how many points, equally spaced along a transverse'
1266     print*, 'cut would you like to examine stresses?'
1267     read*, nseg
1268     dseg=h/(nseg-1)
1269     print*, 'The distance from the left gable is,', xl, '(in.)'
1270     print*, ' '
1271     print*, ' y          fsigly   fctaulyz  fsigpx   csigpx   ft
1272 +aupxy  ctaupxy'
1273     print*, ' (in.)      (p.s.i.) (p.s.i.) (p.s.i.) (p.s.i.) (p
1274 +.s.i.) (p.s.i.)'
1275     print*, ' '
1276     do 1400 ns=1, nseg
1277         y=(h/2.0)+dseg-ns*dseg
1278         ei=((ef*tf**3/6.0)+(ef*tf*(tf+tc)**2/2.0)+(ec*tc**3/12.0))
1279         ip=((2.0*tf+eratio*tc)*h**3)/12.0
1280         fsigly=ws*(h**2/4.0-y**2)*ef*(tc+2.0*tf)/(4.0*ei)
1281         fctaulyz=(ws*y)/(tf+tc)
1282         ap=(tf**2.0+gratio*tc)*h
1283         if(line.eq.'n')then
1284             fsigpx=(ws*xl*(1-xl)*y)/(4.0*ip)
1285             csigpx=eratio*fsigpx
1286             ftaupxy=(ws*((1/2.0)-xl)*3.0)/(2.0*ap)*
1287 + (1.0-(y**2)/(h/2.0)**2)
1288             ctaupxy=gratio*ftaupxy
1289         else
1290             fsigpx=0.0
1291             csigpx=0.0
1292             ftaupxy=(wp*(1/2.0)-xl)/(ap)
1293             ctaupxy=gratio*ftaupxy
1294         endif
1295         write(*,1350) y, fsigly, fctaulyz, fsigpx, csigpx, ftaupxy,
1296 +ctaupxy
1297 1350     format(7f10.2)
1298     print*, ' '
1299 1400     continue
1300     print*, 'Would you like to make another transverse cut? (y/n)'
1301     read*, recut
1302     if(recut.eq.'y')go to 1300
1303 1470     print*, 'Would you like to switch from a folded plate with no l
1304 +ongitudinal'
1305     print*, 'line members to one with, or visa versa? (y/n)'
1306     if(line.eq.'y')print*, 'Presently, there are longitudinal line
1307 +members.'
1308     if(line.eq.'n')print*, 'Presently, there are no longitudinal li
1309 +ne members.'
1310     read*, switch
1311     if(switch.eq.'y')then
1312         if(line.eq.'y')then
1313             line='n'
1314         else
1315             line='y'
1316         print*, 'Enter design value for critical tension or compre
1317 +ssion stress'
1318         print*, 'of the longitudinal line material (k.s.i.)'
1319         read*, ysl
1320         print*, 'Enter youngs modulus of the eave line member (k.
```

```
1321      +s.i.).'
1322          read*, eavee
1323          endif
1324          go to 1060
1325      endif
1326  endif
1327  1500 print*, 'Would you like to switch from a panel with no exterior'
1328      print*, 'insulation to one with, or visa versa? (y/n)'
1329      if(ext2.eq.1)print*, 'Presently, there is no exterior insulation.'
1330      if(ext2.eq.2)print*, 'Presently, there is exterior insulation.'
1331      read*, switch
1332      if(switch.eq.'y')then
1333          if(ext2.eq.1)then
1334              ext2=2
1335          else
1336              ext2=1
1337          endif
1338          ti=0.0
1339          go to 20
1340      endif
1341      print*, 'Would you like to switch from a folded plate to a'
1342      print*, 'ridge beam system, or visa versa? (y/n)'
1343      if(fold.eq.'y')print*, 'Presently, there is a folded plate.'
1344      if(fold.eq.'n')print*, 'Presently, there is a ridge beam.'
1345      read*, switch
1346      if(switch.eq.'y')then
1347          if(fold.eq.'y')then
1348              fold='n'
1349          else
1350              fold='y'
1351          endif
1352          go to 30
1353      endif
1354  2000 print*, 'Do you really want to leave the program? (y/n)'
1355      read*, exit
1356      if(exit.eq.'n')go to 700
1357  end
1358  c
1359  c      Subroutine is for solving quadratic equation
1360  c
1361      subroutine quad(a,b,c,t)
1362      t=(-b+sqrt(b**2-4.0*a*c))/(2.0*a)
1363      return
1364  end
```

A.4 Panel.f Output

Oriented strand board, and a polyurethane foam core are the materials input into the *panel.f* program. The creep factor of four has been established for rigid polyurethane foams under quasi-permanent loads by H. Just [Structural Plastics Design Manual, 84], and has been verified by creep studies at M.I.T.

Page 1

Horizontal distance between eave lines= 384.000 (in.)
Slope of pitch of roof (i.e. 6, means a pitch of 6 to 12)= 9.00000
Live load per horizontal projected area of roof= 40.0000 (p.s.f.)
Wind pressure normal to roof= 33.8000 (p.s.f.)
Allowable displacement factor for panel bending (i.e. defl=span/factor)
live load only, dead and live load= 240.000 180.000
Difference in average temperature of the outer and inner face for:
maximum summer, appropriate winter, and maximum winter=
100.000 70.0000 100.000 (degrees F) respectively
Require R value for roof panel= 30.0000
Maximum depth to be considered for the core= 16.0000 (in.)
Minimum ratio of thickness of core to thickness of face to be
considered= 3.00000
Weight of roofing material= 3.00000 (p.s.f.)
Weight of interior finish material= 2.00000 (p.s.f.)

Youngs modulus of the face material in transverse direction (k.s.i.)
and a creep factor based on a transient live load (-)=
850.000 1.00000
Thermal coefficient of expansion (x10-06 strain/degreeF.), and
the hygroscopic strain gradient (-) of the face material= 5.00000 0.
Poisson ratio for the face material= 0.300000
Design value for the critical flexural stress of the face material= 0.950000
(k.s.i.)
Minimum thickness of face material= 0.250000 (in.)
Incremental production thickness of face material= 0.125000 (in.)
Cost per board foot of face material= 0.570000 (\$.b.f.)
R value per inch for the face material= 1.25000
Weight of face material= 40.0000 (p.c.f.)

Youngs modulus of the core material in transverse direction= 0.800000
(k.s.i.)
Youngs modulus of the core material in out-of-plane direction= 0.800000
(k.s.i.)
Out-of-plane shear modulus of the core material (k.s.i.),
and a creep factor based on a transient live load (-)=
0.800000 4.00000
Poisson ratio for the core material= 0.300000
Design value for the critical shear stress of the core material=
3.30000e-02 (k.s.i.)
Incremental production thickness of core material= 0.500000 (in.)
Cost of core material per board foot= 0.220000 (\$.b.f.)
R value per inch for the core material= 6.00000
Weight of core material= 2.00000 (p.c.f.)
Cost of structural adhesive per square foot= 0. (\$.s.f.)

Longitudinal length of span between gable lines= 480.000 (in.)
Width of the panel element= 96.0000 (in.)
In-plane shear modulus of the face material= 210.000 (k.s.i.)
Design value for critical shear stress of the face material= 1.04500
(k.s.i.).
In-plane shear modulus of the core material= 0.800000 (k.s.i.)
Design value for critical tension or compressi on stress of the
longitudinal line material= 2.30000 (k.s.i.)
Youngs modulus of the eave line member= 2000.00 (k.s.i.).
Area of the eave line member= 3.61730 (in.**2).

Slope distance between eave and ridge= 240.000 (in.)
Allowable maximum deflection for the live load; liv e and dead load
acting on the horizontal projected area of roof (in.)= 1.00000 1.33333

Page 2

core (in.)	face (in.)	weight (p.s.f.)	R	defl. (in.)	cost (\$s.f.)	fail. mode
16.0	0.375	10.2	96.9	1.12	3.95	2.1
15.5	0.375	10.1	93.9	1.16	3.84	2.1
15.0	0.500	10.8	91.3	1.12	3.87	2.1
14.5	0.500	10.8	88.3	1.17	3.76	2.1
14.0	0.625	11.5	85.6	1.15	3.79	2.1
13.5	0.625	11.4	82.6	1.20	3.68	2.1
13.0	0.750	12.2	79.9	1.20	3.71	2.1
12.5	0.875	12.9	77.2	1.21	3.75	2.1
12.0	1.00	13.7	74.5	1.23	3.78	2.1
11.5	1.25	15.3	72.1	1.23	3.95	2.1
11.0	1.38	16.0	69.4	1.25	3.99	2.1
10.5	1.50	16.8	66.8	1.28	4.02	2.1
10.0	1.75	18.3	64.4	1.29	4.20	2.1
9.50	2.00	19.9	62.0	1.30	4.37	2.1
9.00	2.13	20.7	59.3	1.33	4.40	2.1
8.50	2.50	23.1	57.3	1.32	4.72	2.2

1=No constraint 2.1-.5=Stiffness 3=Face yielding 4=Face wrinkling
5=R value requirements 6=Folded plate deflections 7=Folded plate shear

The final thickness of the core is 13.5000 (in.).
The final thickness of the face is 0.625000 (in.).
The final weight of the panel is 11.4167 (p.s.f.).
The final R value of the panel is 82.5625
The final cost of the panel is 3.68250 (\$s.f.).

Allowable vertical ridge deflection is 2.00000 (in.).
Final vertical ridge deflection is 0.420603 (in.).
Allowable horizontal eave deflection is 2.00000 (in.).
Final horizontal eave deflection is 0.314743 (in.).

Page 3

Horizontal distance between eave lines= 384.000 (in.)
Slope of pitch of roof (i.e. 6, means a pitch of 6 to 12)= 9.00000
Live load per horizontal projected area of roof= 40.0000 (p.s.f.)
Wind pressure normal to roof= 33.8000 (p.s.f.)
Allowable displacement factor for panel bending (i.e. defl=span/factor)
live load only, dead and live load= 240.000 180.000
Difference in average temperature of the outer and inner face for:
maximum summer, appropriate winter, and maximum winter=
0. 0. 0. (degrees F) respectively
Require R value for roof panel= 30.0000
Maximum depth to be considered for the core= 16.0000 (in.)
Minimum ratio of thickness of core to thickness of face to be
considered= 3.00000
Weight of roofing material= 3.00000 (p.s.f.)
Weight of interior finish material= 2.00000 (p.s.f.)

Youngs modulus of the face material in transverse direction (k.s.i.)
and a creep factor based on a transient live load (-)=
850.000 1.00000
Thermal coefficient of expansion (x10-06 strain/degreeF.), and
the hygroscopic strain gradient (-) of the face material= 5.00000 0.
Poisson ratio for the face material= 0.300000
Design value for the critical flexural stress of the face material= 0.950000
(k.s.i.)
Minimum thickness of face material= 0.250000 (in.)
Incremental production thickness of face material= 0.125000 (in.)
Cost per board foot of face material= 0.570000 (\$.b.f.)
R value per inch for the face material= 1.25000
Weight of face material= 40.0000 (p.c.f.)

Youngs modulus of the core material in transverse direction= 0.800000
(k.s.i.)
Youngs modulus of the core material in out-of-plane direction= 0.800000
(k.s.i.)
Out-of-plane shear modulus of the core material (k.s.i.),
and a creep factor based on a transient live load (-)=
0.800000 4.00000
Poisson ratio for the core material= 0.300000
Design value for the critical shear stress of the core material=
3.30000e-02 (k.s.i.)
Incremental production thickness of core material= 0.500000 (in.)
Cost of core material per board foot= 0.220000 (\$.b.f.)
R value per inch for the core material= 6.00000
Weight of core material= 2.00000 (p.c.f.)
Cost of structural adhesive per square foot= 0. (\$.s.f.)

Longitudinal length of span between gable lines= 480.000 (in.)
Width of the panel element= 96.0000 (in.)
In-plane shear modulus of the face material= 210.000 (k.s.i.)
Design value for critical shear stress of the face material= 1.04500
(k.s.i.).
In-plane shear modulus of the core material= 0.800000 (k.s.i.)
Design value for critical tension or compressi on stress of the
longitudinal line material= 2.30000 (k.s.i.)
Youngs modulus of the eave line member= 2000.00 (k.s.i.).
Area of the eave line member= 3.41802 (in.**2).

Slope distance between eave and ridge= 240.000 (in.)
Allowable maximum deflection for the live load; liv e and dead load
acting on the horizontal projected area of roof (in.)= 1.00000 1.33333

Page 4

core (in.)	face (in.)	weight (p.s.f.)	R	defl. (in.)	cost (\$s.f.)	fail. mode
16.0	0.250	9.33	96.6	1.11	3.81	1.0
15.5	0.250	9.25	93.6	1.16	3.70	1.0
15.0	0.375	10.0	90.9	1.04	3.73	2.1
14.5	0.375	9.92	87.9	1.09	3.62	2.1
14.0	0.375	9.83	84.9	1.13	3.51	2.1
13.5	0.375	9.75	81.9	1.19	3.40	2.1
13.0	0.500	10.5	79.3	1.13	3.43	2.1
12.5	0.500	10.4	76.3	1.19	3.32	2.1
12.0	0.625	11.2	73.6	1.16	3.35	2.1
11.5	0.625	11.1	70.6	1.22	3.24	2.1
11.0	0.750	11.8	67.9	1.22	3.28	2.1
10.5	0.875	12.6	65.2	1.22	3.31	2.1
10.0	1.00	13.3	62.5	1.24	3.34	2.1
9.50	1.13	14.1	59.8	1.26	3.37	2.1
9.00	1.25	14.8	57.1	1.29	3.40	2.1
8.50	1.38	15.6	54.4	1.32	3.44	2.1
8.00	1.63	17.2	52.1	1.31	3.61	2.2
7.50	1.88	18.8	49.7	1.31	3.79	2.2
7.00	2.13	20.3	47.3	1.31	3.96	2.2

1=No constraint 2.1-.5=Stiffness 3=Face yielding 4=Face wrinkling
5=R value requirements 6=Folded plate deflections 7=Folded plate shear

The final thickness of the core is 11.5000 (in.).
The final thickness of the face is 0.625000 (in.).
The final weight of the panel is 11.0833 (p.s.f.).
The final R value of the panel is 70.5625
The final cost of the panel is 3.24250 (\$s.f.).

Allowable vertical ridge deflection is 2.00000 (in.).
Final vertical ridge deflection is 0.420482 (in.).
Allowable horizontal eave deflection is 2.00000 (in.).
Final horizontal eave deflection is 0.314651 (in.).

Appendix B

Program S.f Hard Copy

S.f is a fortran program which calculates the deflections, shear stresses, bending stresses, twisting stresses for a rectangular isotropic sandwich panel with: two edges simply supported, the other two edges free; four edges simply supported. The geometry, material properties, thermal gradient and summation limits are interactively input. The results are tabulated in column form, where the location in the table correspond to the x and y location of one quarter of the rectangular panel element (refer to shaded area of Figure 5-1 and 5-2). The output is grouped in a vertical column for each (x,y) data point.

```
1 c234567890123456789012345678901234567890123456789012345678901234567890123456789012
2 implicit real(a-h,s-z), integer(i-r)
3 real p, pw, pi, pip, rad, lm, pm, mx11, my11, mxy11, mx1, my1
4 real mxyl, ml, mll
5 integer m, k, j
6 dimension xy(0:10),xw(0:10),xsx(0:10),xsy(0:10),xvx(0:10)
7 dimension xmx(0:10),xmy(0:10),xmxy(0:10)
8 open(unit=1, file='therm', form='print', status='new')
9 c
10 c Program calculates the deflections, shear stresses, bending
11 c stresses, twisting stresses, and uplift corner reactions
12 c for a rectangular isotropic sandwich panel with: two edges simply
13 c supported, the other two edges free; four edges simply supported.
14 c
15 c print*, 'Program calculates the deflections, shear stresses,'
16 c print*, 'bending stresses, twisting stresses, and uplift corner'
17 c print*, 'reactions for a rectangular isotropic sandwich panel'
18 c print*, 'with: two edges simply supported, the other two edges'
19 c print*, 'free; four edges simply supported.'
20 c print*, ' '
21 c print*, ' '
22 c print*, 'Enter horizontal distance between eave lines (in.).'
23 c read*, b2
24 c print*, 'Enter slope of pitch of roof (i.e. 6, means a pitch of 6
25 c +to 12).'
26 c read*, p
27 c print*, 'Enter the width of the panel element (in.).'
28 c read*, pw
29 c print*, 'Enter youngs modulus of the face material in transverse d
30 c +irection (p.s.i.).'
31 c read*, e
32 c print*, 'Enter poisson ratio for the face material.'
33 c read*, vf
34 c print*, 'Enter out-of-plane shear modulus of the core material (p.
35 c +s.i.).'
36 c read*, gc
37 c Print*, 'Enter thickness of the faces (in.)'
38 c read*, tf
39 c print*, 'Enter thickness of the core material (in.)'
40 c read*, tc
41 c print*, 'Enter thermal coefficient of expansion (strain/degrees F)'
42 c read*, alp
43 c print*, 'Enter thermal gradient (degrees F)'
44 c read*, te
45 c b2=384.
46 c p=9.
47 c e=850000.
48 c gc=800.
49 c tf=1.
50 c tc=12.
51 c alp=.000005
52 c te=100.
53 c vf=0.3
54 c pi=atan(1.0)*4.0
55 c pip=p/12.0
56 c rad=atan(pip)
57 c h=b2/(2.0*cos(rad))
58 c ef=e/(1.0-vf**2)
59 c ei=(ef*tf**3/6.0)+(ef*tf*(tf+tc)**2/2.0)
60 c a=h
61 c b=pw
62 c t=(tc+tf)**2/tc
63 c 47 print*, ' Enter the ultimate value for m (odd)'
64 c read*, r
65 c print*, ' '
66 c
```

```
67 c      Let the summation begin.
68 c
69 c      Two edges simply supported, the other two edges free.
70 c
71       do 10 k=0,4,1
72         x=real(k)*a/8.0
73         do 100 j=0,4,1
74           y=b*j/8.0
75           xy(j)=y
76           w11=0.0
77           sx11=0.0
78           sy11=0.0
79           v11=0.0
80           mx11=0.0
81           my11=0.0
82           mxy11=0.0
83           do 1000 m=1,r,2
84             lm=pi*m/a
85             am=lm*b/2.0
86             pm=sqrt(lm**2+((2.0*gc*t)/((1.0-vf)*ei)))
87             gm=pm*b/2.0
88             bbm=(8.0*alp*(1.0-vf**2)*te/(lm**3*a*t))*
89             +      sinh(am)/((3.0+vf+2.0*(1.0-vf)*lm**2*ei/(gc*t))*
90             +      sinh(2.0*am)-2.0*(1.0-vf)*am-
91             +      2.0*lm*(1.0-vf)*ei/(gc*t)*pm*
92             +      (cosh(2.0*am)-1.0)/tanh(gm))
93             eem=bbm*2.0*lm**3*ei*sinh(am)/sinh(gm)
94             aam=bbm*((1.0+vf)/(1.0-vf))-am/tanh(am)
95             w1=(aam*cosh(lm*y)+bbm*lm*y*sinh(lm*y))*sin(lm*x)
96             sx1=(eem*(pm/lm)*cosh(pm*y)-
97             +      2.0*lm**3*ei*bbm*cosh(lm*y))*cos(lm*x)
98             sy1=(eem*sinh(pm*y)-
99             +      2.0*lm**3*ei*bbm*sinh(lm*y))*sin(lm*x)
100            v1=bbm*lm**3*((5.0-vf-(1.0-vf)*am/tanh(am)+
101            +      (2.0*(1.0-vf)*ei*lm**2/(gc*t))*cosh(lm*y)+
102            +      (1.0-vf)*lm*y*sinh(lm*y)-
103            +      (2.0*pm*sinh(am)/(lm*sinh(gm)))*
104            +      (((1.0-vf)*ei*lm**2/(gc*t))+2.0)*cosh(pm*y))
105            mx1=(lm**2*((1.0-vf)*aam-2.0*vf*bbm)*cosh(lm*y)+
106            +      (1.0-vf)*bbm*lm*sinh(lm*y))+
107            +      ((1.0-vf)/(gc*t))*(eem*pm*cosh(pm*y)-
108            +      2.0*lm**4*ei*bbm*cosh(lm*y))*sin(lm*x)
109            my1=(lm**2*((1.0-vf)*aam+bbm)*cosh(lm*y)+
110            +      (1.0-vf)*bbm*lm*y*sinh(lm*y))-
111            +      ((1.0-vf)/(gc*t))*(eem*pm*cosh(pm*y)-
112            +      2.0*lm**4*ei*bbm*cosh(lm*y))*sin(lm*x)
113            mxy1=(lm**2*((aam+bbm)*sinh(lm*y)+
114            +      bbm*lm*y*cosh(lm*y))-
115            +      (1.0/(2.0*lm*gc*t))*
116            +      (eem*(pm**2+lm**2)*sinh(pm*y)-
117            +      4.0*lm**5*ei*bbm*sinh(lm*y))*cos(lm*x)
118            w11=w11+w1
119            sx11=sx11+sx1
120            sy11=sy11+sy1
121            v11=v11+v1
122            mx11=mx11+mx1
123            my11=my11+my1
124            mxy11=mxy11+mxy1
125      1000 continue
126            xw(j)=w11-(alp*te*(1+vf)/t)*(x*(a-x)/2.0)
127            xv11(j)=v11*ei
128            xsx(j)=sx11/(tc+tf)
129            xsy(j)=sy11/(tc+tf)
130            xmx(j)=mx11*ei*t*ef/(ei*2)
131            xmy(j)=((alp*te*ei*(1.0+vf)/t)-ei*my11)*t*ef/(ei*2)
132            xmx11(j)=(1.0-vf)*ei*mxy11*t*ef/(ei*2)
```

```

133     100     continue
134           if(k.eq.0)then
135             print*, ' panel height (x) is', a, '(origin at s.s. edge)'
136             print*, ' panel width (y) is', pw, '(origin at midwidth of
137 +s.s. edge)'
138             print*, '
139             print*, 'Listed sequentially (vertically):'
140             print*, ' Deflection (in.)'
141             print*, ' Core shear in the xz plane (p.s.i.)'
142             print*, ' Core shear in the yz plane (p.s.i.)'
143             print*, ' Normal stress in face in x direction (p.s.i.)'
144             print*, ' Normal stress in face in y direction (p.s.i.)'
145             print*, ' Twisting stress in face (p.s.i.)'
146             print*, '
147             print*, ' x y (in.):'
148             write(*,600)xy(0),xy(1),xy(2),xy(3),xy(4)
149             print*, '(in.)'
150             print*, '
151           endif
152           write(*,700)x,xw(0),xw(1),xw(2),xw(3),xw(4)
153           write(*,600)xsx(0),xsx(1),xsx(2),xsx(3),xsx(4)
154           write(*,600)xsy(0),xsy(1),xsy(2),xsy(3),xsy(4)
155           write(*,600)xmx(0),xmx(1),xmx(2),xmx(3),xmx(4)
156           write(*,600)xmy(0),xmy(1),xmy(2),xmy(3),xmy(4)
157           write(*,600)xmxy(0),xmxy(1),xmxy(2),xmxy(3),xmxy(4)
158           print*, '
159           if(k.eq.0)then
160             write(1,*)' Two simply supported, the other two edges free.'
161             write(1,*)'
162             write(1,*)' Temperature gradient is (degree Fahrenheit)', te
163             write(1,*)' Coefficient of expansion is, alp, '(strain per
164 + degree Fahrenheit)'
165             write(1,*)' Face thickness is', tf, '(in.)'
166             write(1,*)' Modulus of elasticity is', e, '(p.s.i.)'
167             write(1,*)' Core thickness is', tc, '(in.)'
168             write(1,*)' Shear modulus of core is', gc, '(p.s.i.)'
169             write(1,*)'
170             write(1,*)' Panel height (x) is', a, '(origin at s.s. edge)'
171             write(1,*)' Panel width (y) is', pw, '(origin at midwidth o
172 +f s.s. edge)'
173             write(1,*)' Ultimate value for m is, r
174             write(1,*)'
175             write(1,*)'Listed sequentially (vertically):'
176             write(1,*)' Deflection (in.)'
177             write(1,*)' Core shear in the xz plane (p.s.i.)'
178             write(1,*)' Core shear in the yz plane (p.s.i.)'
179             write(1,*)' Normal stress in face in x direction (p.s.i.)'
180             write(1,*)' Normal stress in face in y direction (p.s.i.)'
181             write(1,*)' Twisting stress in face (p.s.i.)'
182             write(1,*)'
183             write(1,*)' x y (in.):'
184             write(1,600)xy(0),xy(1),xy(2),xy(3),xy(4)
185             write(1,*)' (in.)'
186             write(1,*)'
187 c             write(1,*)' Edge reactions (lb./in.):'
188 c             write(1,600)xvx(0),xvx(1),xvx(2),xvx(3),xvx(4)
189 c             write(1,*)'
190           endif
191           write(1,700)x,xw(0),xw(1),xw(2),xw(3),xw(4)
192           write(1,600)xsx(0),xsx(1),xsx(2),xsx(3),xsx(4)
193           write(1,600)xsy(0),xsy(1),xsy(2),xsy(3),xsy(4)
194           write(1,600)xmx(0),xmx(1),xmx(2),xmx(3),xmx(4)
195           write(1,600)xmy(0),xmy(1),xmy(2),xmy(3),xmy(4)
196           write(1,600)xmxy(0),xmxy(1),xmxy(2),xmxy(3),xmxy(4)
197           write(1,*)'
198     10     continue

```

```

199      write(1,8)
200 c
201 c      Let the summation begin.
202 c
203 c      Four edges simply supported.
204 c
205      do 30 k=0,4,1
206          x=k*a/8.0
207          do 300 j=0,4,1
208              y=b*j/8.0
209              xy(j)=y
210              w11=0.0
211              sx11=0.0
212              sy11=0.0
213              v11=0.0
214              m11=0.0
215              mxy11=0.0
216              do 3000 m=1,r,2
217                  lm=pi*m/a
218                  am=lm*b/2.0
219                  w1=(sin(lm*x)/m**3)*(1.0-cosh(lm*y)/cosh(am))
220                  v1=cosh(lm*y)/(cosh(am))
221                  m1=sin(lm*x)*cosh(lm*y)/(m*cosh(am))
222                  mxy1=cos(lm*x)*sinh(lm*y)/(m*cosh(am))
223                  w11=w11+w1
224                  sx11=sx11+sx1
225                  sy11=sy11+syl
226                  v11=v11+v1
227                  m11=m11+m1
228                  mxy11=mxy11+mxy1
229          3000      continue
230                  xw(j)=-4.0*alp*te*(1+vf)*a**2/(pi**3*t)*w11
231                  xv(xj)=-v11*4.0*alp*te*(1-vf**2)*ei/(a*t)
232                  xmx(j)=m11*4.0*alp*te*(1-vf**2)*ei/(pi*t)*t*ef/(ei*2)
233                  xmy(j)=(alp*te*(1-vf**2)*ei/(t)-m11*4.0*alp*te*
234                  +(1-vf**2)*ei/(pi*t))*t*ef/(ei*2)
235                  xmxxy(j)=mxy11*4.0*alp*te*(1-vf**2)*ei/(pi*t)*t*ef/(ei*2)
236          300      continue
237          if(k.eq.0)then
238              print*, ' Four edges simply supported.'
239              print*, ' '
240              print*, ' panel height (x) is', a, '(origin at s.s. edge)'
241              print*, ' panel width (y) is', pw, '(origin at midwidth of s
242          +.s edge)'
243              print*, ' '
244              print*, ' Listed sequentially (vertically):'
245              print*, ' Deflection (in.)'
246              print*, ' Normal stress in face in x direction (p.s.i.)'
247              print*, ' Normal stress in face in y direction (p.s.i.)'
248              print*, ' Twisting stress in face (p.s.i.)'
249              print*, ' '
250              print*, '      x                      y (in.):'
251              write(*,600)xy(0),xy(1),xy(2),xy(3),xy(4)
252              print*, ' (in.) '
253              print*, ' '
254 c          print*, ' edge reactions:'
255 c          write(*,600)xvx(0),xvx(1),xvx(2),xvx(3),xvx(4)
256 c          print*, ' '
257          endif
258          write(*,700)x,xw(0),xw(1),xw(2),xw(3),xw(4)
259          write(*,600)xmx(0),xmx(1),xmx(2),xmx(3),xmx(4)
260          write(*,600)xmy(0),xmy(1),xmy(2),xmy(3),xmy(4)
261          write(*,600)xmxxy(0),xmxxy(1),xmxxy(2),xmxxy(3),xmxxy(4)
262          print*, ' '
263          if(k.eq.0)then
264              write(1,*)' Four edges simply supported.'

```

```
265         write(1,*)' '  
266         write(1,*)' Temperature gradient is (degree Fahrenheit)', te  
267         write(1,*)' Coefficient of expansion is', alp, '(strain per  
268 + degree Fahrenheit)'  
269         write(1,*)' Face thickness is', tf, '(in.)'  
270         write(1,*)' Modulus of elasticity is', e, '(p.s.i.)'  
271         write(1,*)' Core thickness is', tc, '(in.)'  
272         write(1,*)' Shear modulus of core is', gc, '(p.s.i.)'  
273         write(1,*)' '  
274         write(1,*)' Panel height (x) is', a, '(origin at s.s. edge)'  
275         write(1,*)' Panel width (y) is', pw, '(origin at midwidth of  
276 + s.s. edge)'  
277         write(1,*)' Ultimate value for m is', r  
278         write(1,*)' '  
279         write(1,*)' Listed sequentially (vertically):'  
280         write(1,*)' Deflection (in.)'  
281         write(1,*)' Normal stress in face in x direction (p.s.i.)'  
282         write(1,*)' Normal stress in face in y direction (p.s.i.)'  
283         write(1,*)' Twisting stress in face (p.s.i.)'  
284         write(1,*)' '  
285         write(1,*)' x y (in.):'  
286         write(1,600)xy(0),xy(1),xy(2),xy(3),xy(4)  
287         write(1,*)' (in.)'  
288         write(1,*)' '  
289 c         write(1,*)' Edge reactions:'  
290 c         write(1,600)xvx(0),xvx(1),xvx(2),xvx(3),xvx(4)  
291 c         write(1,*)' '  
292         endif  
293         write(1,700)x,xw(0),xw(1),xw(2),xw(3),xw(4)  
294         write(1,600)xmx(0),xmx(1),xmx(2),xmx(3),xmx(4)  
295         write(1,600)xmy(0),xmy(1),xmy(2),xmy(3),xmy(4)  
296         write(1,600)xmxy(0),xmxy(1),xmxy(2),xmxy(3),xmxy(4)  
297         write(1,*)' '  
298 30        continue  
299         write(1,8)  
300         go to 47  
301 800       format(14x,5(1x, g10.3))  
302 900       format(1x, f5.1, 6(1x, g10.3))  
303 600       format(6x,5(1x, g10.3))  
304 700       format(1x, f5.1, 5(1x, g10.3))  
305 8         format('1')  
306         end
```

B.1 S.f Output

Oriented strand board, and a polyurethane foam core are the materials input into the *s.f* program. The face and core thicknesses have been selected from the output of program *panel.f*: face thickness is one inch, the core thickness is twelve inches. A panel element width of 96 inches and 48 inches is run through the program. The panel length is 20 feet. The thermal coefficient of expansion is that of O.S.B. parallel to the transverse direction of the panel. The thermal gradient is 100°F. The summation limits are set just under the number of summations which creates number overflow (10^{34}). For the second run of the program, the summation limit is reduced by a value of two, to characterize the precision and estimate the error in summation limits.

Two simply supported, the other two edges free.

Temperature gradient is (degree Fahrenheit) 100.000
 Coefficient of expansion is, 5.00000e-06 (strain per degree Fahrenheit)
 Face thickness is 1.00000 (in.)
 Modulus of elasticity is 850000. (p.s.i.)
 Core thickness is 12.0000 (in.)
 Shear modulus of core is 800.000 (p.s.i.)

Panel height (x) is 240.000 (origin at s.s. edge)
 Panel width (y) is 48.0000 (origin at midwidth of s.s. edge)
 Ultimate value for m is, 125

Listed sequentially (vertically):

Deflection (in.)
 Core shear in the xz plane (p.s.i.)
 Core shear in the yz plane (p.s.i.)
 Normal stress in face in x direction (p.s.i.)
 Normal stress in face in y direction (p.s.i.)
 Twisting stress in face (p.s.i.)

x (in.)	y (in.):				
	0.	6.00	12.0	18.0	24.0
0.	0.	0.	0.	0.	0.
	-0.281	-0.243	-0.116	0.160	0.931
	0.	0.	0.	0.	0.
	0.	0.	0.	0.	0.
	304.	304.	304.	304.	304.
	0.	27.7	57.5	92.1	-0.523e-01
30.0	-0.115	-0.115	-0.113	-0.110	-0.105
	-0.559e-01	-0.417e-01	-0.400e-02	0.410e-01	0.656e-01
	0.	-0.293e-01	-0.452e-01	-0.365e-01	-0.608e-06
	-38.1	-31.3	-11.7	17.9	84.0
	161.	163.	168.	177.	184.
	0.	-6.92	-11.5	-10.2	-0.521e-02
60.0	-0.195	-0.195	-0.193	-0.189	-0.185
	-0.250e-03	0.769e-04	0.601e-03	0.218e-03	-0.238e-02
	0.	-0.106e-02	-0.135e-02	-0.725e-03	-0.166e-05
	-1.47	-0.945	0.294	1.39	1.17
	172.	172.	172.	173.	173.
	0.	-0.610	-0.864	-0.599	-0.553e-02
90.0	-0.243	-0.242	-0.241	-0.237	-0.233
	0.261e-03	0.201e-03	0.338e-04	-0.189e-03	-0.511e-03
	0.	0.113e-03	0.180e-03	0.153e-03	-0.701e-06
	0.145	0.124	0.610e-01	-0.515e-01	-15.4
	173.	173.	173.	173.	173.
	0.	0.180e-01	0.324e-01	0.304e-01	0.597e-02
120.0	-0.259	-0.258	-0.257	-0.253	-0.249
	-0.441e-08	-0.506e-08	-0.455e-08	0.188e-08	0.585e-07
	0.	0.155e-04	0.217e-04	0.125e-04	-0.587e-06
	0.212e-01	0.151e-01	-0.129e-03	-0.214e-01	-19.7
	173.	173.	173.	173.	173.
	0.	0.276e-05	0.382e-05	0.626e-05	0.280e-07

Four edges simply supported.

Temperature gradient is (degree Fahrenheit) 100.000
 Coefficient of expansion is, 5.00000e-06 (strain per degree Fahrenheit)
 Face thickness is 1.00000 (in.)
 Modulus of elasticity is 850000. (p.s.i.)
 Core thickness is 12.0000 (in.)
 Shear modulus of core is 800.000 (p.s.i.)

Panel height (x) is 240.000 (origin at s.s. edge)
 Panel width (y) is 48.0000 (origin at midwidth of s.s. edge)
 Ultimate value for m is, 125

Listed sequentially (vertically):

Deflection (in.)
 Normal stress in face in x direction (p.s.i.)
 Normal stress in face in y direction (p.s.i.)
 Twisting stress in face (p.s.i.)

x (in.)	y (in.):				
	0.	6.00	12.0	18.0	24.0
0.	0.	0.	0.	0.	0.
	0.	0.	0.	0.	0.
	213.	213.	213.	213.	213.
	0.	54.5	119.	218.	608.
30.0	-0.114e-01	-0.107e-01	-0.861e-02	-0.508e-02	0.
	175.	178.	185.	198.	211.
	37.7	35.0	27.0	14.8	1.94
	0.	14.3	26.7	35.2	36.2
60.0	-0.130e-01	-0.122e-01	-0.978e-02	-0.571e-02	0.
	207.	208.	209.	210.	213.
	5.33	4.93	3.77	2.04	-0.121e-01
	0.	2.04	3.77	4.92	3.81
90.0	-0.133e-01	-0.124e-01	-0.994e-02	-0.580e-02	0.
	212.	212.	212.	212.	213.
	0.763	0.705	0.540	0.292	-0.825
	0.	0.281	0.519	0.678	-0.856e-01
120.0	-0.133e-01	-0.125e-01	-0.996e-02	-0.581e-02	0.
	212.	212.	212.	212.	214.
	0.210	0.194	0.149	0.803e-01	-1.07
	0.	0.508e-06	0.154e-05	0.393e-05	0.117e-03

Two simply supported, the other two edges free.

Temperature gradient is (degree Fahrenheit) 100.000
 Coefficient of expansion is, 5.00000e-06 (strain per degree Fahrenheit)
 Face thickness is 1.00000 (in.)
 Modulus of elasticity is 850000. (p.s.i.)
 Core thickness is 12.0000 (in.)
 Shear modulus of core is 800.000 (p.s.i.)

Panel height (x) is 240.000 (origin at s.s. edge)
 Panel width (y) is 48.0000 (origin at midwidth of s.s. edge)
 Ultimate value for m is, 123

Listed sequentially (vertically):

Deflection (in.)
 Core shear in the xz plane (p.s.i.)
 Core shear in the yz plane (p.s.i.)
 Normal stress in face in x direction (p.s.i.)
 Normal stress in face in y direction (p.s.i.)
 Twisting stress in face (p.s.i.)

x (in.)	y (in.):				
	0.	6.00	12.0	18.0	24.0
0.	0.	0.	0.	0.	0.
	-0.281	-0.243	-0.116	0.160	0.931
	0.	0.	0.	0.	0.
	0.	0.	0.	0.	0.
	304.	304.	304.	304.	304.
	0.	27.7	57.5	92.1	-0.571e-01
30.0	-0.115	-0.115	-0.113	-0.110	-0.105
	-0.559e-01	-0.417e-01	-0.400e-02	0.410e-01	0.655e-01
	0.	-0.293e-01	-0.452e-01	-0.365e-01	-0.608e-06
	-38.1	-31.3	-11.7	17.8	47.7
	161.	163.	168.	177.	183.
	0.	-6.92	-11.5	-10.2	-0.705e-02
60.0	-0.195	-0.195	-0.193	-0.189	-0.185
	-0.250e-03	0.769e-04	0.601e-03	0.218e-03	-0.211e-02
	0.	-0.106e-02	-0.135e-02	-0.725e-03	-0.166e-05
	-1.47	-0.945	0.294	1.39	-26.6
	172.	172.	172.	173.	172.
	0.	-0.610	-0.864	-0.598	-0.215e-02
90.0	-0.243	-0.242	-0.241	-0.237	-0.233
	0.261e-03	0.201e-03	0.338e-04	-0.189e-03	-0.159e-03
	0.	0.113e-03	0.180e-03	0.154e-03	-0.701e-06
	0.145	0.124	0.610e-01	-0.500e-01	-0.362
	173.	173.	173.	173.	173.
	0.	0.180e-01	0.324e-01	0.315e-01	0.104e-01
120.0	-0.259	-0.258	-0.257	-0.253	-0.249
	-0.441e-08	-0.506e-08	-0.455e-08	0.188e-08	0.614e-07
	0.	0.155e-04	0.217e-04	0.127e-04	-0.587e-06
	0.212e-01	0.151e-01	-0.129e-03	-0.175e-01	19.5
	173.	173.	173.	173.	173.
	0.	0.276e-05	0.382e-05	0.627e-05	0.639e-07

Four edges simply supported.

Temperature gradient is (degree Fahrenheit) 100.000
 Coefficient of expansion is, 5.00000e-06 (strain per degree Fahrenheit)
 Face thickness is 1.00000 (in.)
 Modulus of elasticity is 850000. (p.s.i.)
 Core thickness is 12.0000 (in.)
 Shear modulus of core is 800.000 (p.s.i.)

Panel height (x) is 240.000 (origin at s.s. edge)
 Panel width (y) is 48.0000 (origin at midwidth of s.s. edge)
 Ultimate value for m is, 123

Listed sequentially (vertically):

Deflection (in.)
 Normal stress in face in x direction (p.s.i.)
 Normal stress in face in y direction (p.s.i.)
 Twisting stress in face (p.s.i.)

x (in.)	y (in.):				
	0.	6.00	12.0	18.0	24.0
0.	0.	0.	0.	0.	0.
	0.	0.	0.	0.	0.
	213.	213.	213.	213.	213.
	0.	54.5	119.	218.	606.
30.0	-0.114e-01	-0.107e-01	-0.861e-02	-0.508e-02	0.
	175.	178.	185.	198.	213.
	37.7	35.0	27.0	14.8	-0.554e-01
	0.	14.3	26.7	35.2	35.4
60.0	-0.130e-01	-0.122e-01	-0.978e-02	-0.571e-02	0.
	207.	208.	209.	210.	214.
	5.33	4.93	3.77	2.04	-1.54
	0.	2.04	3.77	4.92	5.34
90.0	-0.133e-01	-0.124e-01	-0.994e-02	-0.580e-02	0.
	212.	212.	212.	212.	212.
	0.763	0.705	0.540	0.292	0.380e-02
	0.	0.281	0.519	0.678	1.91
120.0	-0.133e-01	-0.125e-01	-0.996e-02	-0.581e-02	0.
	212.	212.	212.	212.	211.
	0.210	0.194	0.149	0.804e-01	1.09
	0.	0.508e-06	0.154e-05	0.393e-05	0.133e-03

Two simply supported, the other two edges free.

Temperature gradient is (degree Fahrenheit) 100.000
 Coefficient of expansion is, 5.00000e-06 (strain per degree Fahrenheit)
 Face thickness is 1.00000 (in.)
 Modulus of elasticity is 850000. (p.s.i.)
 Core thickness is 12.0000 (in.)
 Shear modulus of core is 800.000 (p.s.i.)

Panel height (x) is 240.000 (origin at s.s. edge)
 Panel width (y) is 96.0000 (origin at midwidth of s.s. edge)
 Ultimate value for m is, 63

Listed sequentially (vertically):

Deflection (in.)
 Core shear in the xz plane (p.s.i.)
 Core shear in the yz plane (p.s.i.)
 Normal stress in face in x direction (p.s.i.)
 Normal stress in face in y direction (p.s.i.)
 Twisting stress in face (p.s.i.)

x (in.)	y (in.):				
	0.	12.0	24.0	36.0	48.0
0.	0.	0.	0.	0.	0.
	-0.518	-0.451	-0.224	0.287	1.79
	0.	0.	0.	0.	0.
	0.	0.	0.	0.	0.
	304.	304.	304.	304.	304.
	0.	30.0	61.4	96.1	-0.123e-01
30.0	-0.122	-0.120	-0.116	-0.107	-0.920e-01
	-0.325	-0.264	-0.751e-01	0.237	0.578
	0.	-0.109	-0.191	-0.187	-0.132e-06
	-68.8	-66.0	-51.4	-0.252	218.
	183.	181.	177.	183.	207.
	0.	1.79	-1.73	-9.55	-0.772e-03
60.0	-0.205	-0.203	-0.196	-0.184	-0.166
	-0.104	-0.782e-01	-0.904e-02	0.761e-01	0.129
	0.	-0.532e-01	-0.822e-01	-0.667e-01	0.385e-11
	-35.2	-29.2	-11.5	15.7	101.
	165.	166.	170.	176.	183.
	0.	-5.18	-8.78	-8.11	-0.117e-01
90.0	-0.254	-0.251	-0.244	-0.231	-0.213
	-0.212e-01	-0.149e-01	0.425e-03	0.156e-01	0.178e-01
	0.	-0.142e-01	-0.206e-01	-0.150e-01	-0.185e-05
	-9.67	-7.37	-1.33	5.97	54.3
	169.	170.	171.	174.	175.
	0.	-2.05	-3.16	-2.54	-0.357e-02
120.0	-0.270	-0.267	-0.260	-0.247	-0.229
	0.188e-07	0.147e-07	0.103e-08	-0.176e-07	0.126e-07
	0.	-0.457e-02	-0.615e-02	-0.380e-02	0.117e-05
	-3.24	-2.24	0.217	2.64	43.5
	171.	171.	172.	173.	174.
	0.	0.360e-06	0.237e-05	0.414e-05	-0.130e-07

Four edges simply supported.

Temperature gradient is (degree Fahrenheit) 100.000
Coefficient of expansion is, 5.00000e-06 (strain per degree Fahrenheit)
Face thickness is 1.00000 (in.)
Modulus of elasticity is 850000. (p.s.i.)
Core thickness is 12.0000 (in.)
Shear modulus of core is 800.000 (p.s.i.)

Panel height (x) is 240.000 (origin at s.s. edge)
Panel width (y) is 96.0000 (origin at midwidth of s.s. edge)
Ultimate value for m is, 63

Listed sequentially (vertically):

Deflection (in.)
Normal stress in face in x direction (p.s.i.)
Normal stress in face in y direction (p.s.i.)
Twisting stress in face (p.s.i.)

x	y (in.):				
(in.)	0.	12.0	24.0	36.0	48.0
0.	0.	0.	0.	0.	0.
	0.	0.	0.	0.	0.
	213.	213.	213.	213.	213.
	0.	54.5	119.	218.	610.
30.0	-0.327e-01	-0.308e-01	-0.252e-01	-0.153e-01	0.
	115.	121.	138.	169.	207.
	97.2	91.9	74.9	43.6	5.51
	0.	34.6	67.8	95.0	106.
60.0	-0.453e-01	-0.426e-01	-0.343e-01	-0.203e-01	0.
	174.	177.	185.	197.	210.
	38.5	35.7	27.5	15.0	2.99
	0.	14.0	26.1	34.5	37.4
90.0	-0.499e-01	-0.468e-01	-0.375e-01	-0.220e-01	0.
	196.	198.	201.	206.	210.
	16.2	15.0	11.5	6.22	2.29
	0.	4.67	8.64	11.3	12.2
120.0	-0.510e-01	-0.478e-01	-0.383e-01	-0.224e-01	0.
	202.	203.	205.	208.	210.
	10.7	9.85	7.54	4.08	2.11
	0.	-0.180e-05	-0.300e-05	-0.198e-05	0.555e-04

Two simply supported, the other two edges free.

Temperature gradient is (degree Fahrenheit) 100.000
 Coefficient of expansion is, 5.00000e-06 (strain per degree Fahrenheit)
 Face thickness is 1.00000 (in.)
 Modulus of elasticity is 850000. (p.s.i.)
 Core thickness is 12.0000 (in.)
 Shear modulus of core is 800.000 (p.s.i.)

Panel height (x) is 240.000 (origin at s.s. edge)
 Panel width (y) is 96.0000 (origin at midwidth of s.s. edge)
 Ultimate value for m is, 61

Listed sequentially (vertically):

Deflection (in.)
 Core shear in the xz plane (p.s.i.)
 Core shear in the yz plane (p.s.i.)
 Normal stress in face in x direction (p.s.i.)
 Normal stress in face in y direction (p.s.i.)
 Twisting stress in face (p.s.i.)

x (in.)	y (in.):				
	0.	12.0	24.0	36.0	48.0
0.	0.	0.	0.	0.	0.
	-0.518	-0.451	-0.224	0.287	1.79
	0.	0.	0.	0.	0.
	0.	0.	0.	0.	0.
	304.	304.	304.	304.	304.
	0.	30.0	61.4	96.1	-0.913e-02
30.0	-0.122	-0.120	-0.116	-0.107	-0.920e-01
	-0.325	-0.264	-0.751e-01	0.237	0.577
	0.	-0.109	-0.191	-0.187	-0.132e-06
	-68.8	-66.0	-51.4	-0.254	187.
	183.	181.	177.	183.	207.
	0.	1.79	-1.73	-9.56	0.217e-02
60.0	-0.205	-0.203	-0.196	-0.184	-0.166
	-0.104	-0.782e-01	-0.904e-02	0.761e-01	0.128
	0.	-0.532e-01	-0.822e-01	-0.667e-01	0.385e-11
	-35.2	-29.2	-11.5	15.6	44.0
	165.	166.	170.	176.	182.
	0.	-5.18	-8.78	-8.11	-0.944e-02
90.0	-0.254	-0.251	-0.244	-0.231	-0.213
	-0.212e-01	-0.149e-01	0.425e-03	0.156e-01	0.172e-01
	0.	-0.142e-01	-0.206e-01	-0.150e-01	-0.185e-05
	-9.67	-7.37	-1.33	5.96	-20.2
	169.	170.	171.	174.	174.
	0.	-2.05	-3.16	-2.54	-0.235e-02
120.0	-0.270	-0.267	-0.260	-0.247	-0.229
	0.188e-07	0.147e-07	0.103e-08	-0.176e-07	0.364e-08
	0.	-0.457e-02	-0.615e-02	-0.380e-02	0.117e-05
	-3.24	-2.24	0.217	2.63	-37.2
	171.	171.	172.	173.	173.
	0.	0.360e-06	0.237e-05	0.413e-05	0.605e-08

Four edges simply supported.

Temperature gradient is (degree Fahrenheit) 100.000
 Coefficient of expansion is, 5.00000e-06 (strain per degree Fahrenheit)
 Face thickness is 1.00000 (in.)
 Modulus of elasticity is 850000. (p.s.i.)
 Core thickness is 12.0000 (in.)
 Shear modulus of core is 800.000 (p.s.i.)

Panel height (x) is 240.000 (origin at s.s. edge)
 Panel width (y) is 96.0000 (origin at midwidth of s.s. edge)
 Ultimate value for m is, 61

Listed sequentially (vertically):

Deflection (in.)
 Normal stress in face in x direction (p.s.i.)
 Normal stress in face in y direction (p.s.i.)
 Twisting stress in face (p.s.i.)

x (in.)	y (in.):				
	0.	12.0	24.0	36.0	48.0
0.	0.	0.	0.	0.	0.
	0.	0.	0.	0.	0.
	213.	213.	213.	213.	213.
	0.	54.5	119.	218.	606.
30.0	-0.327e-01	-0.308e-01	-0.252e-01	-0.153e-01	0.
	115.	121.	138.	169.	209.
	97.2	91.9	74.9	43.6	3.86
	0.	34.6	67.8	95.0	102.
60.0	-0.453e-01	-0.426e-01	-0.343e-01	-0.203e-01	0.
	174.	177.	185.	197.	213.
	38.5	35.7	27.5	15.0	-0.496e-01
	0.	14.0	26.1	34.5	34.4
90.0	-0.499e-01	-0.468e-01	-0.376e-01	-0.220e-01	0.
	196.	198.	201.	206.	214.
	16.2	15.0	11.5	6.22	-1.68
	0.	4.67	8.64	11.3	10.6
120.0	-0.510e-01	-0.478e-01	-0.383e-01	-0.224e-01	0.
	202.	203.	205.	208.	215.
	10.7	9.85	7.54	4.08	-2.18
	0.	-0.180e-05	-0.300e-05	-0.198e-05	0.298e-04

Appendix C

Program B.f Hard Copy

Program *bf* is a fortran program which calculates the reaction along the panel edges for a rectangular isotropic sandwich panel with: two edges simply supported, the other two edges free; four edges simply supported. The geometry, material properties and thermal gradient, fastener location and summation limits are interactively input. The location of the fastener and the fastener reaction are listed in column form (refer to Figure 5-1 and 5-2)).

```
1 c234567890123456789012345678901234567890123456789012345678901234567890123456789012
2 implicit real(a-h,s-z), integer(i-r)
3 real p, pw, pm, pi, pip, rad, lm
4 integer m
5 open(unit=1, file='hard', form='print', status='new')
6 c
7 c Program calculates the fastener reactions for a rectangular
8 c isotropic sandwich panel with: two edges simply supported,
9 c the other two edges free; four edges simply supported.
10 c Variations in the twisting moment create a singularity at the
11 c corner. As the summation limits approach infinity, the corner
12 c reactions approach infinity. In calculating the edge reactions
13 c for fasteners, this inconsistency in the solution of a
14 c mathematical model can be remedied by applying the laws of
15 c equilibrium and symmetry. The outer fastener reaction nearest
16 c the corner is set equal to the negative value of the
17 c edge reaction obtained from integrating from the midpoint of
18 c the outer fastener and the adjacent fastener to the midpoint
19 c of the panel length. Reactions of fasteners inside of the
20 c outer corner fastener are found by integrating the edge
21 c reactions over the respective tributary areas of
22 c the fastener.
23 c
24 print*, ' Program calculates the fastener reactions for a '
25 print*, ' rectangular isotropic sandwich panel with: two'
26 print*, ' edges simply supported, the other two edges free;'
27 print*, ' four edges simply supported. Variations in the'
28 print*, ' twisting moment create a singularity at the'
29 print*, ' corner. As the summation limits approach infinity,'
30 print*, ' the corner reactions approach infinity. In'
31 print*, ' calculating the edge reactions for fasteners, this'
32 print*, ' inconsistency in the solution of a mathematical'
33 print*, ' model can be remedied by applying the laws of'
34 print*, ' equilibrium and symmetry. The outer fastener'
35 print*, ' reaction nearest the corner is set equal to the'
36 print*, ' negative value edge reaction obtained from'
37 print*, ' integrating from the midpoint of the outer fastener'
38 print*, ' and the adjacent fastener to the midpoint'
39 print*, ' of the panel length. Reactions of fasteners inside'
40 print*, ' of the outer corner fastener are found by integrating'
41 print*, ' the edge reactions over the respective tributary areas'
42 print*, ' of the fastener.'
43 print*, ' '
44 print*, ' '
45 print*, 'Enter horizontal distance between eave lines (in.).'
46 read*, b2
47 print*, 'Enter slope of pitch of roof (i.e. 6, means a pitch of 6
48 +to 12).'
49 read*, p
50 print*, 'Enter the width of the panel element (in.).'
51 read*, pw
52 print*, 'Enter youngs modulus of the face material in transverse d
53 +irection (p.s.i.).'
54 read*, e
55 print*, 'Enter poisson ratio for the face material.'
56 read*, vf
57 print*, 'Enter out-of-plane shear modulus of the core material (p
58 +.s.i.).'
59 read*, gc
60 print*, 'Enter thickness of the faces (in.)'
61 read*, tf
62 print*, ' '
63 print*, 'Enter thickness of the core material (in.)'
64 read*, tc
65 print*, 'Enter thermal coefficient of expansion (strain/degrees F)'
66 read*, alp
```

```
67 print*, 'Enter thermal gradient (degrees F)'  
68 read*, te  
69 b2=384.  
70 p=9.  
71 e=850000.  
72 gc=800.  
73 tf=1.  
74 tc=12.  
75 alp=.000005  
76 te=100.  
77 vf=0.3  
78 t=(tc+tf)**2/tc  
79 pi=atan(1.0)*4.0  
80 pip=p/12.0  
81 rad=atan(pip)  
82 h=b2/(2.0*cos(rad))  
83 ef=e/(1.0-vf**2)  
84 ei=(ef*tf**3/6.0)+(ef*tf*(tf+tc)**2/2.0)  
85 a=h  
86 b=pw  
87 print*, 'fastner reactions for two edges simply supported and the  
88 +other two edges free'  
89 print*, ' '  
90 47 print*, ' panel width (y) is', b, '(origin at mid-width)'  
91 print*, ' enter the number of fastners along width'  
92 read*, n  
93 print*, ' enter the edge distance for the fastners'  
94 read*, ed  
95 print*, ' enter the ultimate value for m (odd)'  
96 read*, k  
97 print*, ' '  
98 print*, ' Fasteners along width'  
99 print*, ' y(in.) R(lbs.)'  
100 print*, ' '  
101 bd=(b-2.0*ed)/(n-1)  
102 dint=b/2.0-ed-bd/2.0  
103 write(1,*)' Program calculates the fastener reactions for a '  
104 write(1,*)' rectangular isotropic sandwich panel with: two '  
105 write(1,*)' edges simply supported, the other two edges free; '  
106 write(1,*)' four edges simply supported. Variations in the '  
107 write(1,*)' twisting moment create a singularity at the '  
108 write(1,*)' corner. As the summation limits approach infinity, '  
109 write(1,*)' the corner reactions approach infinity. In '  
110 write(1,*)' calculating the edge reactions for fasteners, this '  
111 write(1,*)' inconsistency in the solution of a mathematical '  
112 write(1,*)' model can be remedied by applying the laws of '  
113 write(1,*)' equilibrium and symmetry. The outer fastener '  
114 write(1,*)' reaction nearest the corner is set equal to the '  
115 write(1,*)' negative value edge reaction obtained from '  
116 write(1,*)' integrating from the midpoint of the outer fastener '  
117 write(1,*)' and the adjacent fastener to the midpoint '  
118 write(1,*)' of the panel length. Reactions of fasteners inside '  
119 write(1,*)' of the outer corner fastener are found by integrating '  
120 write(1,*)' the edge reactions over the respective tributary areas  
121 +'  
122 write(1,*)' of the fastener.'  
123 write(1,*)' '  
124 write(1,*)' '  
125 write(1,*)' fastner reactions for two edges simply supported and t  
126 +the other two edges free'  
127 write(1,*)' '  
128 write(1,*)' Temperature gradient is (degree Fahrenheit)', te  
129 write(1,*)' Coefficient of expansion is, ', alp, '(strain per  
130 + degree Fahrenheit)'  
131 write(1,*)' Face thickness is', tf, '(in.)'  
132 write(1,*)' Modulus of elasticity is', e, '(p.s.i.)'
```

```

133 write(1,*)' Core thickness is', tc, '(in.)'
134 write(1,*)' Shear modulus of core is', gc, '(p.s.i.)'
135 write(1,*)' panel width (y) is', b, '(origin at midwidth)'
136 write(1,*)' Panel height (x) is', a, '(origin at s.s. edge)'
137 write(1,*)' ultimate value for m is', k
138 write(1,*)' edge distance for the fastners is', ed
139 write(1,*)'
140 write(1,*)' y(in.) R(lbs.)'
141 write(1,*)'
142 c
143 c two edges simply supported, the other two edges free
144 c
145 sb=0.0
146 do 100 i=0,200
147 y=dint-bd*i
148 if(y.lt.0.0)go to 100
149 dloc=y+bd/2.0
150 b11=0.0
151 do 1000 m=1,k,2
152 lm=pi*m/a
153 am=lm*b/2.0
154 pm=sqrt(lm**2+((2.0*gc*t)/((1.0-vf)*ei)))
155 gm=pm*b/2.0
156 bbm=(8.0*alp*(1.0-vf**2)*te/(lm**3*a*t))/
157 + ((3.0+vf+2.0*(1.0-vf)*lm**2*ei/(gc*t))*
158 + 2.0*cosh(am)-2.0*(1.0-vf)*am/sinh(am)-
159 + 2.0*lm*(1.0-vf)*ei/(gc*t)*pm*
160 + 2.0*sinh(am)/tanh(gm))
161 eem=bbm*2.0*lm**3*ei*sinh(am)/sinh(gm)
162 aam=bbm*((1.0+vf)/(1.0-vf))-am/tanh(am)
163 b1=eem/lm*sinh(pm*y)-2.0*lm**2*ei*bbm*sinh(lm*y)-
164 + (1.0-vf)*ei*(lm**2*((aam+bbm)*sinh(lm*y)+
165 + bbm*lm*y*cosh(lm*y)))-
166 + (1.0/(2.0*lm*gc*t))*
167 + (eem*(pm**2+lm**2)*sinh(pm*y)-
168 + 4.0*lm**5*ei*bbm*sinh(lm*y))
169 b11=b11+b1
170 1000 continue
171 bolt=-b11-sb
172 sb=sb+bolt
173 write(*,3) dloc, bolt
174 write(1,3) dloc, bolt
175 100 continue
176 print*, ' '
177 print*, ' Sum of R(lbs.)'
178 write(*,7) sb
179 write(1,*) ' '
180 write(1,*) ' Sum of R(lbs.)'
181 write(1,7) sb
182 write(1,8)
183 print*, ' fastner reactions for four edges simply supported'
184 print*, ' '
185 print*, ' panel height (x) is', a, '(origin at s.s. edge)'
186 print*, ' enter number of fastners along the height?'
187 read*, o
188 print*, ' panel width (y) is', b, '(origin at midwidth)'
189 print*, ' number of fastners along the width?'
190 read*, n
191 print*, ' enter the edge distance for the fastners (in.)'
192 read*, ed
193 print*, ' enter the ultimate value for m (odd)'
194 read*, r
195 print*, ' Fasteners along height Fasteners along width'
196 print*, ' x(in.) Rx(lbs.) y(in.) Ry(lbs.)'
197 print*, ' '
198 write(1,*)' Program calculates the fastener reactions for a '

```

```
199 write(1,*)' rectangular isotropic sandwich panel with: two'
200 write(1,*)' edges simply supported, the other two edges free;'
201 write(1,*)' four edges simply supported. Variations in the'
202 write(1,*)' twisting moment create a singularity at the'
203 write(1,*)' corner. As the summation limits approach infinity,'
204 write(1,*)' the corner reactions approach infinity. In'
205 write(1,*)' calculating the edge reactions for fasteners, this'
206 write(1,*)' inconsistency in the solution of a mathematical'
207 write(1,*)' model can be remedied by applying the laws of'
208 write(1,*)' equilibrium and symmetry. The outer fastener'
209 write(1,*)' reaction nearest the corner is set equal to the'
210 write(1,*)' negative value edge reaction obtained from'
211 write(1,*)' integrating from the midpoint of the outer fastener'
212 write(1,*)' and the adjacent fastener to the midpoint'
213 write(1,*)' of the panel length. Reactions of fasteners inside'
214 write(1,*)' of the outer corner fastener are found by integrating'
215 write(1,*)' the edge reactions over the respective tributary areas
216 +
217 write(1,*)' of the fastener.'
218 write(1,*)' '
219 write(1,*)' '
220 write(1,*)' Fastner reactions for four edges simply supported' .
221 write(1,*)' '
222 write(1,*)' Temperature gradient is (degree Fahrenheit)', te
223 write(1,*)' Coefficient of expansion is,', alp, '(strain per
224 + degree Fahrenheit)'
225 write(1,*)' Face thickness is', tf, '(in.)'
226 write(1,*)' Modulus of elasticity is', e, '(p.s.i.)'
227 write(1,*)' Core thickness is', tc, '(in.)'
228 write(1,*)' Shear modulus of core is', gc, '(p.s.i.)'
229 write(1,*)' Panel height (x) is', a, '(origin at s.s. edge)'
230 write(1,*)' Panel width (y) is', b, '(origin at midwidth)'
231 write(1,*)' Ultimate value for m is,', r
232 write(1,*)' Edge distance for the fastners is,', ed, '(in.)'
233 write(1,*)' '
234 write(1,*)' Fasteners along height Fasteners along widt
235 +h'
236 write(1,*)' x(in.) Rx(lbs.) y(in.) Ry(lbs
237 +.)'
238 write(1,*)' '
239 bdy=(b-2.0*ed)/(n-1)
240 bdx=(a-2.0*ed)/(o-1)
241 dinty=b/2.0-ed-bdy/2.0
242 dintx=ed+bdx/2.0
243 half=a/2.0
244 if(n.gt.o)then
245 k=n
246 else
247 k=o
248 endif
249 bx=0.0
250 by=0.0
251 sbx=0.0
252 sby=0.0
253 do 300 i=0,k
254 y=dinty-bdy*i
255 dlocy=y+bdy/2.0
256 x=dintx+bdx*i
257 dlocx=ed+bdx*i
258 bllx=0.0
259 bllly=0.0
260 do 3000 m=1,r,2
261 lm=pi*m/a
262 am=lm*b/2.0
263 check=lm*y
264 if(am.gt.50.0.or.check.gt.50.0.or.check.le.-80.0)then
```

```
265          blx=(cos(lm*x))/m*
266      +          4.0*alp*te*(1-vf**2)*ei/(pi*t)
267      endif
268      if(am.gt.50.0.or.check.gt.50.0.or.check.le.-80.0)go to 37
269      bly=sinh(lm*y)/(m*cosh(am))*
270      +          4.0*alp*te*(1-vf**2)*ei/(pi*t)
271      blx=(cos(lm*x))*sinh(am)/(m*cosh(am))*
272      +          4.0*alp*te*(1-vf**2)*ei/(pi*t)
273      billy=billy+bly
274      37      bllx=bllx+blx
275      3000    continue
276      bolty=billy-by
277      boltx=bllx-bx
278      by=billy
279      bx=bllx
280      if(dlocy.lt.0.0.and.dlocx.gt.half)then
281          go to 23
282      elseif(dlocy.lt.0.0.and.dlocx.le.half)then
283          write(*,3)dlocx,boltx
284          write(1,3)dlocx,boltx
285          sbx=sbx+boltx
286      elseif(dlocx.gt.half.and.dlocy.ge.0.0)then
287          write(*,2)dlocy,bolty
288          write(1,2)dlocy,bolty
289          sby=sby+bolty
290      elseif(dlocy.ge.0.0.and.dlocx.le.half)then
291          write(*,5)dlocx,boltx,dlocy,bolty
292          write(1,5)dlocx,boltx,dlocy,bolty
293          sbx=sbx+boltx
294          sby=sby+bolty
295      endif
296      300    continue
297      23      print*,' '
298      c      print*,'          Sum of Rx(lbs.)          Sum of Ry(lb
299      c      +s.)'
300      c      write(*,6) sbx,sby
301      c      print*,' '
302      c      write(1,*) ' '
303      c      write(1,*) '          Sum of Rx(lbs.)          Sum of Ry(lb
304      c      +s.)'
305      c      write(1,6) sbx,sby
306      c      write(1,*) ' '
307      write(1,8)
308      2      format(35x, f6.2, 8x, g10.3)
309      3      format(1x, f6.2, 8x, g10.3)
310      5      format(1x, f6.2, 8x, g10.3, 10x, f6.2, 8x, g10.3)
311      6      format(15x, g10.3, 10x, 14x, g10.3)
312      7      format(15x, g10.3)
313      8      format('1')
314      go to 47
315      end
```

C.1 B.f Output

Oriented strand board, and a polyurethane foam core are the materials input into the *sf* program. The face and core thicknesses have been selected from the output of program *panel.f*: face thickness is one inch, the core thickness is twelve inches. A panel element width of 96 inches and 48 inches is run through the program. The panel length is 20 feet. The thermal coefficient of expansion is that of O.S.B. parallel to the transverse direction of the panel. The thermal gradient is 100°F. The summation limits are set just under the number of summations which creates number overflow (10^{34}) for the case of two edges simply supported, the other two edges free. For the second run of the program in this boundary case, the summation limit is reduced by a value of two, to characterize the precision and estimate the error in summation limits. The summation limits are set at a reasonably high value for the case of four edges simply supported. For the second run of the program in this boundary case, the summation limit is reduced by a value of 1000, to characterize the precision and estimate the error in summation limits. As the summation limits are increased in both boundary cases the load carried by the outside fastener approaches an ever larger number. This behavior is modified by the integration over the tributary area of each fastener location.

Program calculates the fastener reactions for a rectangular isotropic sandwich panel with: two edges simply supported, the other two edges free; four edges simply supported. Variations in the twisting moment create a singularity at the corner. As the summation limits approach infinity, the corner reactions approach infinity. In calculating the edge reactions for fasteners, this inconsistency in the solution of a mathematical model can be remedied by applying the laws of equilibrium and symmetry. The outer fastener reaction nearest the corner is set equal to the negative value edge reaction obtained from integrating from the midpoint of the outer fastener and the adjacent fastener to the midpoint of the panel length. Reactions of fasteners inside of the outer corner fastener are found by integrating the edge reactions over the respective tributary areas of the fastener.

fastner reactions for two edges simply supported and the other two edges free

Temperature gradient is (degree Fahrenheit) 100.000
Coefficient of expansion is, 5.00000e-06
(strain per degree Fahrenheit)
Face thickness is 1.00000 (in.)
Modulus of elasticity is 850000. (p.s.i.)
Core thickness is 12.0000 (in.)
Shear modulus of core is 800.000 (p.s.i.)
panel width (y) is 48.0000 (origin at midwidth)
Panel height (x) is 240.000 (origin at s.s. edge)
ultimate value for m is, 243
edge distance for the fastners is, 2.00000

y(in.)	R(lbs.)
22.00	0.137e+04
20.00	-157.
18.00	-149.
16.00	-141.
14.00	-135.
12.00	-130.
10.00	-126.
8.00	-122.
6.00	-120.
4.00	-118.
2.00	-117.

Sum of R(lbs.)
58.4

Program calculates the fastener reactions for a rectangular isotropic sandwich panel with: two edges simply supported, the other two edges free; four edges simply supported. Variations in the twisting moment create a singularity at the corner. As the summation limits approach infinity, the corner reactions approach infinity. In calculating the edge reactions for fasteners, this inconsistency in the solution of a mathematical model can be remedied by applying the laws of equilibrium and symmetry. The outer fastener reaction nearest the corner is set equal to the negative value edge reaction obtained from integrating from the midpoint of the outer fastener and the adjacent fastener to the midpoint of the panel length. Reactions of fasteners inside of the outer corner fastener are found by integrating the edge reactions over the respective tributary areas of the fastener.

Fastner reactions for four edges simply supported

Temperature gradient is (degree Fahrenheit) 100.000
 Coefficient of expansion is, 5.00000e-06 (strain per degree Fahrenheit)
 Face thickness is 1.00000 (in.)
 Modulus of elasticity is 850000. (p.s.i.)
 Core thickness is 12.0000 (in.)
 Shear modulus of core is 800.000 (p.s.i.)
 Panel height (x) is 240.000 (origin at s.s. edge)
 Panel width (y) is 48.0000 (origin at midwidth)
 Ultimate value for m is, 5000
 Edge distance for the fastners is, 2.00000 (in.)

Fasteners along height		Fasteners along width	
x(in.)	Rx(lbs.)	y(in.)	Ry(lbs.)
2.00	0.379e+04	22.00	0.377e+04
4.00	-828.	20.00	-840.
6.00	-538.	18.00	-561.
8.00	-392.	16.00	-428.
10.00	-303.	14.00	-351.
12.00	-244.	12.00	-302.
14.00	-202.	10.00	-269.
16.00	-172.	8.00	-246.
18.00	-146.	6.00	-231.
20.00	-125.	4.00	-221.
22.00	-106.	2.00	-215.
24.00	-91.6	0.	-213.
26.00	-80.0		
28.00	-70.5		
30.00	-61.9		
32.00	-53.7		
34.00	-46.2		
36.00	-40.0		
38.00	-35.4		
40.00	-31.6		
42.00	-28.0		
44.00	-24.3		
46.00	-20.7		
48.00	-17.9		
50.00	-15.9		
52.00	-14.5		
54.00	-12.9		
56.00	-11.2		

58.00	-9.33
60.00	-7.95
62.00	-7.15
64.00	-6.70
66.00	-6.09
68.00	-5.19
70.00	-4.16
72.00	-3.43
74.00	-3.17
76.00	-3.15
78.00	-2.99
80.00	-2.46
82.00	-1.81
84.00	-1.40
86.00	-1.37
88.00	-1.54
90.00	-1.57
92.00	-1.21
94.00	-0.769
96.00	-0.494
98.00	-0.567
100.00	-0.828
102.00	-0.922
104.00	-0.700
106.00	-0.305
108.00	-0.103
110.00	-0.243
112.00	-0.546
114.00	-0.685
116.00	-0.503
118.00	-0.170
120.00	-0.489e-02

Program calculates the fastener reactions for a rectangular isotropic sandwich panel with: two edges simply supported, the other two edges free; four edges simply supported. Variations in the twisting moment create a singularity at the corner. As the summation limits approach infinity, the corner reactions approach infinity. In calculating the edge reactions for fasteners, this inconsistency in the solution of a mathematical model can be remedied by applying the laws of equilibrium and symmetry. The outer fastener reaction nearest the corner is set equal to the negative value edge reaction obtained from integrating from the midpoint of the outer fastener and the adjacent fastener to the midpoint of the panel length. Reactions of fasteners inside of the outer corner fastener are found by integrating the edge reactions over the respective tributary areas of the fastener.

fastner reactions for two edges simply supported and the other two edges free

Temperature gradient is (degree Fahrenheit) 100.000
Coefficient of expansion is, 5.00000e-06
(strain per degree Fahrenheit)
Face thickness is 1.00000 (in.)
Modulus of elasticity is 850000. (p.s.i.)
Core thickness is 12.0000 (in.)
Shear modulus of core is 800.000 (p.s.i.)
panel width (y) is 48.0000 (origin at midwidth)
Panel height (x) is 240.000 (origin at s.s. edge)
ultimate value for m is, 241
edge distance for the fastners is, 2.00000

y(in.)	R(lbs.)
22.00	0.137e+04
20.00	-157.
18.00	-149.
16.00	-141.
14.00	-135.
12.00	-130.
10.00	-126.
8.00	-122.
6.00	-120.
4.00	-118.
2.00	-117.

Sum of R(lbs.)
58.4

Program calculates the fastener reactions for a rectangular isotropic sandwich panel with: two edges simply supported, the other two edges free; four edges simply supported. Variations in the twisting moment create a singularity at the corner. As the summation limits approach infinity, the corner reactions approach infinity. In calculating the edge reactions for fasteners, this inconsistency in the solution of a mathematical model can be remedied by applying the laws of equilibrium and symmetry. The outer fastener reaction nearest the corner is set equal to the negative value edge reaction obtained from integrating from the midpoint of the outer fastener and the adjacent fastener to the midpoint of the panel length. Reactions of fasteners inside of the outer corner fastener are found by integrating the edge reactions over the respective tributary areas of the fastener.

Fastner reactions for four edges simply supported

Temperature gradient is (degree Fahrenheit) 100.000
 Coefficient of expansion is, 5.00000e-06 (strain per degree Fahrenheit)
 Face thickness is 1.00000 (in.)
 Modulus of elasticity is 850000. (p.s.i.)
 Core thickness is 12.0000 (in.)
 Shear modulus of core is 800.000 (p.s.i.)
 Panel height (x) is 240.000 (origin at s.s. edge)
 Panel width (y) is 48.0000 (origin at midwidth)
 Ultimate value for m is, 4000
 Edge distance for the fastners is, 2.00000 (in.)

Fasteners along height		Fasteners along width	
x(in.)	Rx(lbs.)	y(in.)	Ry(lbs.)
2.00	0.378e+04	22.00	0.377e+04
4.00	-827.	20.00	-840.
6.00	-524.	18.00	-561.
8.00	-395.	16.00	-428.
10.00	-307.	14.00	-351.
12.00	-241.	12.00	-302.
14.00	-205.	10.00	-269.
16.00	-172.	8.00	-246.
18.00	-142.	6.00	-231.
20.00	-126.	4.00	-221.
22.00	-108.	2.00	-215.
24.00	-90.3	0.	-213.
26.00	-81.5		
28.00	-70.9		
30.00	-59.2		
32.00	-54.2		
34.00	-47.4		
36.00	-39.2		
38.00	-36.4		
40.00	-31.9		
42.00	-26.0		
44.00	-24.7		
46.00	-21.7		
48.00	-17.2		
50.00	-16.8		
52.00	-14.7		
54.00	-11.4		
56.00	-11.5		

58.00	-10.1
60.00	-7.41
62.00	-7.86
64.00	-6.94
66.00	-4.74
68.00	-5.45
70.00	-4.81
72.00	-2.96
74.00	-3.79
76.00	-3.37
78.00	-1.78
80.00	-2.69
82.00	-2.40
84.00	-0.972
86.00	-1.94
88.00	-1.75
90.00	-0.451
92.00	-1.42
94.00	-1.32
96.00	-0.934e-01
98.00	-1.11
100.00	-1.02
102.00	0.135
104.00	-0.894
106.00	-0.832
108.00	0.284
110.00	-0.769
112.00	-0.731
114.00	0.353
116.00	-0.699
118.00	-0.684
120.00	0.374

Program calculates the fastener reactions for a rectangular isotropic sandwich panel with: two edges simply supported, the other two edges free; four edges simply supported. Variations in the twisting moment create a singularity at the corner. As the summation limits approach infinity, the corner reactions approach infinity. In calculating the edge reactions for fasteners, this inconsistency in the solution of a mathematical model can be remedied by applying the laws of equilibrium and symmetry. The outer fastener reaction nearest the corner is set equal to the negative value edge reaction obtained from integrating from the midpoint of the outer fastener and the adjacent fastener to the midpoint of the panel length. Reactions of fasteners inside of the outer corner fastener are found by integrating the edge reactions over the respective tributary areas of the fastener.

fastner reactions for two edges simply supported and the other two edges free

Temperature gradient is (degree Fahrenheit) 100.000
Coefficient of expansion is, 5.00000e-06
(strain per degree Fahrenheit)
Face thickness is 1.00000 (in.)
Modulus of elasticity is 850000. (p.s.i.)
Core thickness is 12.0000 (in.)
Shear modulus of core is 800.000 (p.s.i.)
panel width (y) is 96.0000 (origin at midwidth)
Panel height (x) is 240.000 (origin at s.s. edge)
ultimate value for m is, 123
edge distance for the fastners is, 2.00000

y(in.)	R(lbs.)
46.00	0.154e+04
44.00	-37.9
42.00	-58.0
40.00	-62.1
38.00	-64.6
36.00	-66.4
34.00	-67.8
32.00	-68.9
30.00	-69.8
28.00	-70.5
26.00	-71.0
24.00	-71.4
22.00	-71.8
20.00	-72.1
18.00	-72.3
16.00	-72.5
14.00	-72.6
12.00	-72.7
10.00	-72.8
8.00	-72.9
6.00	-72.9
4.00	-73.0
2.00	-73.0
Sum of R(lbs.)	
36.5	

Program calculates the fastener reactions for a rectangular isotropic sandwich panel with: two edges simply supported, the other two edges free; four edges simply supported. Variations in the twisting moment create a singularity at the corner. As the summation limits approach infinity, the corner reactions approach infinity. In calculating the edge reactions for fasteners, this inconsistency in the solution of a mathematical model can be remedied by applying the laws of equilibrium and symmetry. The outer fastener reaction nearest the corner is set equal to the negative value edge reaction obtained from integrating from the midpoint of the outer fastener and the adjacent fastener to the midpoint of the panel length. Reactions of fasteners inside of the outer corner fastener are found by integrating the edge reactions over the respective tributary areas of the fastener.

Fastner reactions for four edges simply supported

Temperature gradient is (degree Fahrenheit) 100.000
 Coefficient of expansion is, 5.00000e-06 (strain per degree Fahrenheit)
 Face thickness is 1.00000 (in.)
 Modulus of elasticity is 850000. (p.s.i.)
 Core thickness is 12.0000 (in.)
 Shear modulus of core is 800.000 (p.s.i.)
 Panel height (x) is 240.000 (origin at s.s. edge)
 Panel width (y) is 96.0000 (origin at midwidth)
 Ultimate value for m is, 5000
 Edge distance for the fastners is, 2.00000 (in.)

Fasteners along height		Fasteners along width	
x(in.)	Rx(lbs.)	y(in.)	Ry(lbs.)
2.00	0.491e+04	46.00	0.488e+04
4.00	-834.	44.00	-817.
6.00	-548.	42.00	-549.
8.00	-405.	40.00	-413.
10.00	-319.	38.00	-332.
12.00	-263.	36.00	-279.
14.00	-224.	34.00	-241.
16.00	-196.	32.00	-213.
18.00	-172.	30.00	-192.
20.00	-152.	28.00	-175.
22.00	-135.	26.00	-161.
24.00	-122.	24.00	-151.
26.00	-111.	22.00	-142.
28.00	-102.	20.00	-134.
30.00	-93.9	18.00	-128.
32.00	-85.8	16.00	-123.
34.00	-78.3	14.00	-119.
36.00	-72.0	12.00	-115.
38.00	-66.9	10.00	-112.
40.00	-62.7	8.00	-110.
42.00	-58.5	6.00	-108.
44.00	-54.1	4.00	-107.
46.00	-49.8	2.00	-107.
48.00	-46.1	0.	-106.
50.00	-43.3		
52.00	-40.9		
54.00	-38.4		
56.00	-35.7		

58.00	-32.9
60.00	-30.6
62.00	-28.9
64.00	-27.5
66.00	-26.0
68.00	-24.2
70.00	-22.4
72.00	-20.8
74.00	-19.8
76.00	-19.0
78.00	-18.1
80.00	-16.9
82.00	-15.6
84.00	-14.6
86.00	-14.0
88.00	-13.6
90.00	-13.2
92.00	-12.3
94.00	-11.5
96.00	-10.8
98.00	-10.5
100.00	-10.4
102.00	-10.2
104.00	-9.74
106.00	-9.12
108.00	-8.71
110.00	-8.69
112.00	-8.85
114.00	-8.88
116.00	-8.63
118.00	-8.25
120.00	-8.07

Program calculates the fastener reactions for a rectangular isotropic sandwich panel with: two edges simply supported, the other two edges free; four edges simply supported. Variations in the twisting moment create a singularity at the corner. As the summation limits approach infinity, the corner reactions approach infinity. In calculating the edge reactions for fasteners, this inconsistency in the solution of a mathematical model can be remedied by applying the laws of equilibrium and symmetry. The outer fastener reaction nearest the corner is set equal to the negative value edge reaction obtained from integrating from the midpoint of the outer fastener and the adjacent fastener to the midpoint of the panel length. Reactions of fasteners inside of the outer corner fastener are found by integrating the edge reactions over the respective tributary areas of the fastener.

fastner reactions for two edges simply supported and the other two edges free

Temperature gradient is (degree Fahrenheit) 100.000
Coefficient of expansion is, 5.00000e-06
(strain per degree Fahrenheit)
Face thickness is 1.00000 (in.)
Modulus of elasticity is 850000. (p.s.i.)
Core thickness is 12.0000 (in.)
Shear modulus of core is 800.000 (p.s.i.)
panel width (y) is 96.0000 (origin at midwidth)
Panel height (x) is 240.000 (origin at s.s. edge)
ultimate value for m is, 121
edge distance for the fastners is, 2.00000

y(in.)	R(lbs.)
46.00	0.154e+04
44.00	-37.9
42.00	-58.0
40.00	-62.1
38.00	-64.6
36.00	-66.4
34.00	-67.8
32.00	-68.9
30.00	-69.8
28.00	-70.5
26.00	-71.0
24.00	-71.4
22.00	-71.8
20.00	-72.1
18.00	-72.3
16.00	-72.5
14.00	-72.6
12.00	-72.7
10.00	-72.8
8.00	-72.9
6.00	-72.9
4.00	-73.0
2.00	-73.0
Sum of R(lbs.)	
36.5	

Program calculates the fastener reactions for a rectangular isotropic sandwich panel with: two edges simply supported, the other two edges free; four edges simply supported. Variations in the twisting moment create a singularity at the corner. As the summation limits approach infinity, the corner reactions approach infinity. In calculating the edge reactions for fasteners, this inconsistency in the solution of a mathematical model can be remedied by applying the laws of equilibrium and symmetry. The outer fastener reaction nearest the corner is set equal to the negative value edge reaction obtained from integrating from the midpoint of the outer fastener and the adjacent fastener to the midpoint of the panel length. Reactions of fasteners inside of the outer corner fastener are found by integrating the edge reactions over the respective tributary areas of the fastener.

Fastner reactions for four edges simply supported

Temperature gradient is (degree Fahrenheit) 100.000
 Coefficient of expansion is, 5.00000e-06 (strain per degree Fahrenheit)
 Face thickness is 1.00000 (in.)
 Modulus of elasticity is 850000. (p.s.i.)
 Core thickness is 12.0000 (in.)
 Shear modulus of core is 800.000 (p.s.i.)
 Panel height (x) is 240.000 (origin at s.s. edge)
 Panel width (y) is 96.0000 (origin at midwidth)
 Ultimate value for m is, 4000
 Edge distance for the fastners is, 2.00000 (in.)

Fasteners along height		Fasteners along width	
x(in.)	Rx(lbs.)	y(in.)	Ry(lbs.)
2.00	0.490e+04	46.00	0.488e+04
4.00	-834.	44.00	-817.
6.00	-535.	42.00	-549.
8.00	-408.	40.00	-413.
10.00	-323.	38.00	-332.
12.00	-260.	36.00	-279.
14.00	-227.	34.00	-241.
16.00	-196.	32.00	-213.
18.00	-168.	30.00	-192.
20.00	-153.	28.00	-175.
22.00	-137.	26.00	-161.
24.00	-120.	24.00	-151.
26.00	-113.	22.00	-142.
28.00	-103.	20.00	-134.
30.00	-91.2	18.00	-128.
32.00	-86.3	16.00	-123.
34.00	-79.5	14.00	-119.
36.00	-71.1	12.00	-115.
38.00	-68.0	10.00	-112.
40.00	-63.0	8.00	-110.
42.00	-56.5	6.00	-108.
44.00	-54.5	4.00	-107.
46.00	-50.7	2.00	-107.
48.00	-45.4	0.	-106.
50.00	-44.1		
52.00	-41.2		
54.00	-36.9		
56.00	-36.0		

58.00	-33.7
60.00	-30.1
62.00	-29.6
64.00	-27.8
66.00	-24.7
68.00	-24.5
70.00	-23.0
72.00	-20.4
74.00	-20.4
76.00	-19.2
78.00	-16.9
80.00	-17.2
82.00	-16.2
84.00	-14.2
86.00	-14.6
88.00	-13.8
90.00	-12.0
92.00	-12.5
94.00	-12.0
96.00	-10.4
98.00	-11.0
100.00	-10.6
102.00	-9.17
104.00	-9.94
106.00	-9.64
108.00	-8.33
110.00	-9.21
112.00	-9.04
114.00	-7.85
116.00	-8.82
118.00	-8.76
120.00	-7.69

Appendix D

Program Sep.f Hard Copy

Program *sep.f* generates load tables for the individual effect of dead, live, seismic, and wind loads on the eave, gable and ridge line. The live, dead, wind and seismic loads and their respective parameters are interactively input, and the resulting load tables for varying pitch, gable to gable length, and eave to eave width are calculated.

```
1 c234567
2 implicit real(a-h,s-z), integer(i-r)
3 real rad, pip
4 integer p
5 character*1 z, plan
6 dimension a(20)
7 open(unit=1, file='co', form='print', status='new')
8 c
9 c This program calculates the effect of dead, live, wind and seismic
10 c loads applied seperately to the roof structure.
11 c
12 print*, 'Enter seismic zone factor'
13 read*, zone
14 print*, 'Enter live load per horizontal projected area of roof (p.
15 +s.f.)'
16 read*, wli
17 print*, 'Enter dead load of the roof (p.s.f.)'
18 read*, wd
19 print*, 'Enter live load per horizontal projected area of roof in
20 +earthquake (p.s.f.)'
21 print*, 'Snow load may be reduced to 75% if approved by building o
22 +fficial'
23 read*, wde
24 if(wli.le.30.0)wde=0.0
25 print*, 'Enter dead load of the wall element (p.s.f.)'
26 read*, wwall
27 print*, 'Enter height of attaching wall height element (ft.)'
28 read*, dl
29 print*, 'Enter wind stagnation pressure at standard height of 30
30 +feet (p.s.f.)'
31 read*, qs
32 print*, 'Enter combined height, exposure and gust factor coefficie
33 +nt'
34 read*, ce
35 wpr=qs*ce
36 print*, 'Are there any plan irregularities of type A,B,C, or D'
37 print*, 'U.B.C. 1988 Table No. 23-N (y/n)?'
38 read*, plan
39 write(1,*)' '
40 write(1,*)' This program calculates the effect of dead, live,'
41 write(1,*)' wind and seismic loads applied seperately to the roof'
42 write(1,*)' structure, given the following parameters: '
43 write(1,*)' '
44 write(1,*)' '
45 write(1,*)' Seismic zone factor = ', zone
46 write(1,*)' Live load per horizontal projected area of roof = ', w
47 +li,' (p.s.f.)'
48 write(1,*)' Dead load of the roof = ', wd,' (p.s.f.)'
49 write(1,*)' Live load per horizontal projected area of roof in a'
50 write(1,*)' earthquake = ', wde,' (p.s.f.)'
51 write(1,*)' Dead load of the wall element = ', wwall,' (p.s.f.)'
52 write(1,*)' Height of attaching wall height element = ', dl,' (ft.)
53 +.'
54 write(1,*)' Wind stagnation pressure at standard height of 30 feet
55 + = ', qs
56 write(1,*)' (p.s.f.)'
57 write(1,*)' Combined height, exposure and gust factor coefficient'
58 +, ce
59 if(plan.eq.'y')then
60 write(1,*)' There is a plan irregularity of type A,B,C, or D'
61 else
62 write(1,*)' There is no plan irregularity of type A,B,C, or D'
63 endif
64 ccccccccccccccccccccccccccccccccccccccccccccccccccccccccccccccccc
65 print*, ' '
66 print*, ' To continue, enter any letter.'
```

```
67      read*, z
68      write(1,1850)
69      c
70      c      Calculate various tables
71      c
72      write(1,*)'          Download at longitudinal wall (lb/ft),
73      + dead load'
74      write(1,*)' '
75      write(1,*)'          Pitch of the roof'
76      write(1,*)' '
77      write(1,*)' Width  3      4      5      6      7      8      9
78      + 10      11      12'
79      write(1,*)' (ft) '
80      print*, ' '          Download at longitudinal wall (lb/ft),
81      + dead load'
82      print*, ' '
83      print*, ' '          Pitch of the roof'
84      print*, ' '
85      print*, ' Width  3      4      5      6      7      8      9
86      + 10      11      12'
87      print*, ' (ft) '
88      do 100 iw=20, 40, 1
89          j=0
90          do 10 p=3, 12, 1
91              pip=p/12.0
92              rad=atan(pip)
93              j=j+1
94              a(j)=iw*wd/(4.0*cos(rad))
95      10      continue
96      write(1,1750) iw,a(1),a(2),a(3),a(4),a(5),a(6),a(7),a(8),a(9)
97      +,a(10)
98      write(*,1750) iw,a(1),a(2),a(3),a(4),a(5),a(6),a(7),a(8),a(9)
99      +,a(10)
100     100  continue
101     write(1,*)' '
102     write(1,*)' '
103     write(1,*)'          Download at longitudinal wall (lb/ft),
104     + live load'
105     write(1,*)' '
106     write(1,*)'          Pitch of the roof'
107     write(1,*)' '
108     write(1,*)' Width  3      4      5      6      7      8      9
109     + 10      11      12'
110     write(1,*)' (ft) '
111     print*, ' '
112     print*, ' '
113     print*, ' '          Download at longitudinal wall (lb/ft),
114     + live load'
115     print*, ' '
116     print*, ' '          Pitch of the roof'
117     print*, ' '
118     print*, ' Width  3      4      5      6      7      8      9
119     + 10      11      12'
120     print*, ' (ft) '
121     do 101 iw=20, 40, 1
122         j=0
123         do 11 p=3, 12, 1
124             if(wli.gt.20.0.and.p.gt.4)then
125                 wl=wli-(atan(real(p)/12.0)
126                 + *45.0/atan(1.0)-20.0)*(wli/40.0-0.5)
127             else
128                 wl=wli
129             endif
130             pip=p/12.0
131             rad=atan(pip)
132             j=j+1
```



```

265 +udinal wall'
266   write(1,*)'                               (lb/ft), endwall tributary loa
267 +d'
268   write(1,*)'                               Divide by the length of span to obtain seism
269 +ic shear (lb/ft)'
270   write(1,*)' '
271   write(1,*)'                               Pitch of the roof'
272   write(1,*)' '
273   write(1,*)' Width 3      4      5      6      7      8      9
274 + 10      11      12'
275   write(1,*)' (ft) '
276   print*, ' '                               Seismic shear along (parallel to) longit
277 +udinal wall'
278   print*, ' '                               (lb/ft), endwall tributary loa
279 +d'
280   print*, ' '                               Divide by the length of span to obtain seism
281 +ic shear (lb/ft)'
282   print*, ' '
283   print*, ' '                               Pitch of the roof'
284   print*, ' '
285   print*, ' Width 3      4      5      6      7      8      9
286 + 10      11      12'
287   print*, ' (ft) '
288   do 106 iw=20, 40, 1
289     j=0
290     do 16 p=3, 12, 1
291       pip=p/12.0
292       rad=atan(pip)
293       j=j+1
294       a(j)=0.55*0.75*zone*wwall*
295 +(dl*real(iw)+(real(iw))**2*sin(rad)/2.0)
296 16   continue
297     write(1,1750) iw,a(1),a(2),a(3),a(4),a(5),a(6),a(7),a(8),a(9)
298 +,a(10)
299     write(*,1750) iw,a(1),a(2),a(3),a(4),a(5),a(6),a(7),a(8),a(9)
300 +,a(10)
301 106 continue
302   write(1,*)' '
303   write(1,*)' '
304   write(1,*)'                               Seismic shear along (parallel to) longit
305 +udinal wall'
306   write(1,*)'                               (lb/ft), roof tributary load
307 +d'
308   write(1,*)' '
309   write(1,*)'                               Pitch of the roof'
310   write(1,*)' '
311   write(1,*)' Width 3      4      5      6      7      8      9
312 + 10      11      12'
313   write(1,*)' (ft) '
314   print*, ' '
315   print*, ' '
316   print*, ' '                               Seismic shear along (parallel to) longit
317 +udinal wall'
318   print*, ' '                               (lb/ft), roof tributary load
319 +d'
320   print*, ' '
321   print*, ' '                               Pitch of the roof'
322   print*, ' '
323   print*, ' Width 3      4      5      6      7      8      9
324 + 10      11      12'
325   print*, ' (ft) '
326   do 107 iw=20, 40, 1
327     j=0
328     do 17 p=3, 12, 1
329       pip=p/12.0
330       rad=atan(pip)

```



```

661     print*, '          3          4          5          6          7          8          9
662 + 10     11     12'
663     print*, ' '
664     j=0
665     do 40 p=3, 12, 1
666         pip=p/12.0
667         rad=atan(pip)
668         j=j+1
669         a(j)=wd/(2.0*sin(rad))
670 40     continue
671         write(1,1900) a(1),a(2),a(3),a(4),a(5),a(6),a(7),a(8),a(9)
672 +,a(10)
673         write(*,1900) a(1),a(2),a(3),a(4),a(5),a(6),a(7),a(8),a(9)
674 +,a(10)
675         write(1,*)' '
676         write(1,*)' '
677         write(1,*)' '
678         write(1,*)' '
679 + due to plate action'
680         write(1,*)' '
681         write(1,*)' '
682 +hear (lb/ft)'
683         write(1,*)' '
684         write(1,*)' '
685         write(1,*)' '
686         write(1,*)' '
687 + 10     11     12'
688         write(1,*)' '
689         print*, ' '
690         print*, ' '
691         print*, ' '
692         print*, ' '
693 + due to plate action'
694         print*, ' '
695         print*, ' '
696 +hear (lb/ft)'
697         print*, ' '
698         print*, ' '
699         print*, ' '
700         print*, ' '
701 + 10     11     12'
702         print*, ' '
703         j=0
704         do 41 p=3, 12, 1
705             if(wli.gt.20.0.and.p.gt.4)then
706                 wl=wli-(atan(real(p)/12.0)
707 +                 *45.0/atan(1.0)-20.0)*(wli/40.0-0.5)
708             else
709                 wl=wli
710             endif
711             pip=p/12.0
712             rad=atan(pip)
713             j=j+1
714             a(j)=wl*cos(rad)/(2.0*sin(rad))
715 41     continue
716         write(1,1900) a(1),a(2),a(3),a(4),a(5),a(6),a(7),a(8),a(9)
717 +,a(10)
718         write(*,1900) a(1),a(2),a(3),a(4),a(5),a(6),a(7),a(8),a(9)
719 +,a(10)
720         write(1,*)' '
721         write(1,*)' '
722         write(1,*)' The panel to panel shear varies linearly from a maximum
723 +m value'
724         write(1,*)' at the gable line, to one fourth, (1/4), this maximum
725 +value at'
726         write(1,*)' the midspan of the roof.'

```



```
859         b2=(0.65*d1/real(iw)+(cq+0.7)/2.0*wpr*tan(rad)+
860 + (0.7-cq)/2.0*wpr*cos(rad)/(2.0*sin(rad)))
861         if(p.lt.9)then
862             cq=0.9
863         else
864             cq=0.7
865         endif
866         b3=(0.65*d1/real(iw)+(-cq+0.7)/2.0*wpr*tan(rad)+
867 + (0.7+cq)/2.0*wpr*cos(rad)/(2.0*sin(rad)))
868         j=j+1
869         if(b1.gt.b2.and.b1.gt.b3)then
870             a(j)=b1
871         elseif(b2.gt.b3)then
872             a(j)=b2
873         else
874             a(j)=b3
875         endif
876     45     continue
877         write(1,1700) iw,a(1),a(2),a(3),a(4),a(5),a(6),a(7),a(8),a(9)
878 +,a(10)
879         write(*,1700) iw,a(1),a(2),a(3),a(4),a(5),a(6),a(7),a(8),a(9)
880 +,a(10)
881     405 continue
882     1700 format(5x, i2, 1x, 10(1x, f6.2))
883     1750 format(5x, i2, 1x, 10(1x, f6.0))
884     1800 format(5x, i2, 2x, f6.0)
885     1850 format('1')
886     1900 format(8x, 10(1x, f6.2))
887     end
```

D.1 Sep.f Output

The standard load case parameters established in Chapter 6 are input into program.

This program calculates the effect of dead, live, wind and seismic loads applied seperately to the roof structure, given the following parameters:

Seismic zone factor = 0.400000
Live load per horizontal projected area of roof = 40.0000 (p.s.f.).
Dead load of the roof = 10.0000 (p.s.f.).
Live load per horizontal projected area of roof in a
earthquake = 30.0000 (p.s.f.).
Dead load of the wall element = 10.0000 (p.s.f.).
Height of attaching wall height element = 10.0000 (ft.).
Wind stagnation pressure at standard height of 30 feet = 26
(p.s.f.).
Combined height, exposure and gust factor coefficient 1.30000
There is no plan irregularity of type A,B,C, or D

Download at longitudinal wall (lb/ft), dead load

Width (ft)	Pitch of the roof									
	3	4	5	6	7	8	9	10	11	12
20	52.	53.	54.	56.	58.	60.	63.	65.	68.	71.
21	54.	55.	57.	59.	61.	63.	66.	68.	71.	74.
22	57.	58.	60.	61.	64.	66.	69.	72.	75.	78.
23	59.	61.	62.	64.	67.	69.	72.	75.	78.	81.
24	62.	63.	65.	67.	69.	72.	75.	78.	81.	85.
25	64.	66.	68.	70.	72.	75.	78.	81.	85.	88.
26	67.	69.	70.	73.	75.	78.	81.	85.	88.	92.
27	70.	71.	73.	75.	78.	81.	84.	88.	92.	95.
28	72.	74.	76.	78.	81.	84.	88.	91.	95.	99.
29	75.	76.	79.	81.	84.	87.	91.	94.	98.	103.
30	77.	79.	81.	84.	87.	90.	94.	98.	102.	106.
31	80.	82.	84.	87.	90.	93.	97.	101.	105.	110.
32	82.	84.	87.	89.	93.	96.	100.	104.	109.	113.
33	85.	87.	89.	92.	96.	99.	103.	107.	112.	117.
34	88.	90.	92.	95.	98.	102.	106.	111.	115.	120.
35	90.	92.	95.	98.	101.	105.	109.	114.	119.	124.
36	93.	95.	98.	101.	104.	108.	113.	117.	122.	127.
37	95.	98.	100.	103.	107.	111.	116.	120.	125.	131.
38	98.	100.	103.	106.	110.	114.	119.	124.	129.	134.
39	101.	103.	106.	109.	113.	117.	122.	127.	132.	138.
40	103.	105.	108.	112.	116.	120.	125.	130.	136.	141.

Download at longitudinal wall (lb/ft), live load

Width (ft)	Pitch of the roof									
	3	4	5	6	7	8	9	10	11	12
20	200.	200.	193.	184.	174.	166.	158.	150.	144.	138.
21	210.	210.	203.	193.	183.	174.	166.	158.	151.	144.
22	220.	220.	213.	202.	192.	182.	174.	166.	158.	151.
23	230.	230.	222.	211.	201.	191.	181.	173.	165.	158.
24	240.	240.	232.	220.	209.	199.	189.	181.	172.	165.
25	250.	250.	242.	229.	218.	207.	197.	188.	180.	172.
26	260.	260.	251.	239.	227.	216.	205.	196.	187.	179.
27	270.	270.	261.	248.	235.	224.	213.	203.	194.	186.
28	280.	280.	271.	257.	244.	232.	221.	211.	201.	193.
29	290.	290.	281.	266.	253.	240.	229.	218.	208.	199.
30	300.	300.	290.	275.	262.	249.	237.	226.	216.	206.
31	310.	310.	300.	285.	270.	257.	245.	233.	223.	213.
32	320.	320.	310.	294.	279.	265.	253.	241.	230.	220.
33	330.	330.	319.	303.	288.	274.	260.	248.	237.	227.
34	340.	340.	329.	312.	296.	282.	268.	256.	244.	234.
35	350.	350.	339.	321.	305.	290.	276.	263.	252.	241.
36	360.	360.	348.	330.	314.	298.	284.	271.	259.	248.
37	370.	370.	358.	340.	323.	307.	292.	278.	266.	254.
38	380.	380.	368.	349.	331.	315.	300.	286.	273.	261.
39	390.	390.	377.	358.	340.	323.	308.	293.	280.	268.
40	400.	400.	387.	367.	349.	332.	316.	301.	287.	275.

Wind download at longitudinal wall (lb/ft), wind load

Width (ft)	Pitch of the roof									
	3	4	5	6	7	8	9	10	11	12
20	0.	0.	0.	0.	0.	0.	211.	229.	249.	270.
21	0.	0.	0.	0.	0.	0.	222.	241.	261.	284.
22	0.	0.	0.	0.	0.	0.	232.	252.	274.	297.
23	0.	0.	0.	0.	0.	0.	243.	263.	286.	311.
24	0.	0.	0.	0.	0.	0.	253.	275.	299.	324.
25	0.	0.	0.	0.	0.	0.	264.	286.	311.	338.
26	0.	0.	0.	0.	0.	0.	275.	298.	323.	352.
27	0.	0.	0.	0.	0.	0.	285.	309.	336.	365.
28	0.	0.	0.	0.	0.	0.	296.	321.	348.	379.
29	0.	0.	0.	0.	0.	0.	306.	332.	361.	392.
30	0.	0.	0.	0.	0.	0.	317.	344.	373.	406.
31	0.	0.	0.	0.	0.	0.	327.	355.	386.	419.
32	0.	0.	0.	0.	0.	0.	338.	367.	398.	433.
33	0.	0.	0.	0.	0.	0.	349.	378.	411.	446.
34	0.	0.	0.	0.	0.	0.	359.	389.	423.	460.
35	0.	0.	0.	0.	0.	0.	370.	401.	435.	473.
36	0.	0.	0.	0.	0.	0.	380.	412.	448.	487.
37	0.	0.	0.	0.	0.	0.	391.	424.	460.	500.
38	0.	0.	0.	0.	0.	0.	401.	435.	473.	514.
39	0.	0.	0.	0.	0.	0.	412.	447.	485.	527.
40	0.	0.	0.	0.	0.	0.	423.	458.	498.	541.

Wind uplift at longitudinal wall (lb/ft), wind load

Width (ft)	Pitch of the roof									
	3	4	5	6	7	8	9	10	11	12
20	198.	207.	218.	232.	249.	269.	290.	315.	342.	372.
21	207.	217.	229.	244.	262.	282.	305.	331.	359.	390.
22	217.	227.	240.	256.	274.	295.	320.	346.	376.	409.
23	227.	238.	251.	267.	287.	309.	334.	362.	393.	428.
24	237.	248.	262.	279.	299.	322.	349.	378.	411.	446.
25	247.	258.	273.	290.	311.	336.	363.	394.	428.	465.
26	257.	269.	284.	302.	324.	349.	378.	409.	445.	483.
27	267.	279.	295.	314.	336.	363.	392.	425.	462.	502.
28	277.	289.	305.	325.	349.	376.	407.	441.	479.	521.
29	286.	300.	316.	337.	361.	389.	421.	457.	496.	539.
30	296.	310.	327.	349.	374.	403.	436.	472.	513.	558.
31	306.	320.	338.	360.	386.	416.	450.	488.	530.	576.
32	316.	330.	349.	372.	399.	430.	465.	504.	547.	595.
33	326.	341.	360.	383.	411.	443.	479.	520.	564.	613.
34	336.	351.	371.	395.	424.	456.	494.	535.	582.	632.
35	346.	361.	382.	407.	436.	470.	508.	551.	599.	651.
36	356.	372.	393.	418.	448.	483.	523.	567.	616.	669.
37	365.	382.	404.	430.	461.	497.	537.	583.	633.	688.
38	375.	392.	415.	442.	473.	510.	552.	598.	650.	706.
39	385.	403.	425.	453.	486.	524.	566.	614.	667.	725.
40	395.	413.	436.	465.	498.	537.	581.	630.	684.	744.

Wind load along (parallel to) longitudinal wall (lb), wind load
Divide by the length of span to obtain wind shear (lb/ft)

Width (ft)	Pitch of the roof									
	3	4	5	6	7	8	9	10	11	12
20	2730.	2892.	3042.	3180.	3304.	3416.	3515.	3603.	3682.	3751.
21	2894.	3073.	3238.	3390.	3527.	3650.	3760.	3858.	3944.	4020.
22	3061.	3257.	3439.	3606.	3756.	3891.	4012.	4119.	4213.	4296.
23	3231.	3445.	3644.	3826.	3991.	4138.	4270.	4387.	4490.	4581.
24	3404.	3637.	3853.	4051.	4230.	4391.	4535.	4662.	4774.	4873.
25	3579.	3832.	4067.	4281.	4476.	4650.	4806.	4944.	5066.	5174.
26	3757.	4030.	4284.	4517.	4727.	4916.	5084.	5233.	5365.	5482.
27	3937.	4232.	4506.	4757.	4983.	5187.	5368.	5529.	5672.	5797.
28	4120.	4438.	4732.	5002.	5246.	5464.	5659.	5833.	5986.	6121.
29	4306.	4646.	4962.	5251.	5513.	5748.	5957.	6143.	6307.	6452.
30	4494.	4859.	5197.	5506.	5786.	6038.	6261.	6460.	6636.	6791.
31	4686.	5074.	5435.	5766.	6065.	6333.	6572.	6784.	6972.	7138.
32	4879.	5294.	5678.	6030.	6349.	6635.	6890.	7116.	7316.	7492.
33	5076.	5517.	5926.	6300.	6639.	6943.	7214.	7454.	7667.	7854.
34	5275.	5743.	6177.	6574.	6934.	7257.	7544.	7800.	8025.	8225.
35	5477.	5972.	6433.	6854.	7235.	7577.	7882.	8152.	8391.	8602.
36	5681.	6206.	6692.	7138.	7541.	7903.	8226.	8512.	8765.	8988.
37	5888.	6442.	6956.	7427.	7853.	8235.	8576.	8878.	9145.	9381.
38	6098.	6682.	7225.	7721.	8171.	8574.	8933.	9252.	9534.	9782.
39	6310.	6926.	7497.	8020.	8494.	8918.	9297.	9632.	9929.	10191.
40	6525.	7173.	7774.	8324.	8822.	9269.	9667.	10020.	10332.	10608.

Seismic shear along (parallel to) longitudinal wall
(lb/ft), endwall tributary load
Divide by the length of span to obtain seismic shear (lb/ft)

Width (ft)	Pitch of the roof									
	3	4	5	6	7	8	9	10	11	12
20	410.	434.	457.	478.	496.	513.	528.	541.	553.	563.
21	435.	462.	486.	509.	530.	548.	565.	579.	592.	604.
22	460.	489.	517.	542.	564.	584.	603.	619.	633.	645.
23	485.	518.	547.	575.	599.	622.	641.	659.	674.	688.
24	511.	546.	579.	609.	635.	660.	681.	700.	717.	732.
25	538.	576.	611.	643.	672.	699.	722.	743.	761.	777.
26	564.	605.	644.	678.	710.	738.	764.	786.	806.	823.
27	591.	636.	677.	714.	749.	779.	806.	831.	852.	871.
28	619.	667.	711.	751.	788.	821.	850.	876.	899.	919.
29	647.	698.	745.	789.	828.	863.	895.	923.	947.	969.
30	675.	730.	781.	827.	869.	907.	941.	970.	997.	1020.
31	704.	762.	816.	866.	911.	951.	987.	1019.	1047.	1072.
32	733.	795.	853.	906.	954.	997.	1035.	1069.	1099.	1125.
33	762.	829.	890.	946.	997.	1043.	1084.	1120.	1152.	1180.
34	792.	863.	928.	988.	1042.	1090.	1133.	1172.	1205.	1235.
35	823.	897.	966.	1029.	1087.	1138.	1184.	1224.	1260.	1292.
36	853.	932.	1005.	1072.	1133.	1187.	1236.	1278.	1316.	1350.
37	884.	968.	1045.	1116.	1180.	1237.	1288.	1334.	1374.	1409.
38	916.	1004.	1085.	1160.	1227.	1288.	1342.	1390.	1432.	1469.
39	948.	1040.	1126.	1205.	1276.	1340.	1396.	1447.	1491.	1531.
40	980.	1077.	1168.	1250.	1325.	1392.	1452.	1505.	1552.	1593.

Seismic shear along (parallel to) longitudinal wall
(lb/ft), roof tributary load

Width (ft)	Pitch of the roof									
	3	4	5	6	7	8	9	10	11	12
20	102.	104.	107.	111.	115.	119.	124.	129.	134.	140.
21	107.	110.	113.	116.	120.	125.	130.	135.	141.	147.
22	112.	115.	118.	122.	126.	131.	136.	142.	148.	154.
23	117.	120.	123.	127.	132.	137.	142.	148.	154.	161.
24	122.	125.	129.	133.	138.	143.	149.	155.	161.	168.
25	128.	130.	134.	138.	143.	149.	155.	161.	168.	175.
26	133.	136.	139.	144.	149.	155.	161.	168.	175.	182.
27	138.	141.	145.	149.	155.	161.	167.	174.	181.	189.
28	143.	146.	150.	155.	160.	167.	173.	180.	188.	196.
29	148.	151.	156.	160.	166.	173.	179.	187.	195.	203.
30	153.	157.	161.	166.	172.	178.	186.	193.	201.	210.
31	158.	162.	166.	172.	178.	184.	192.	200.	208.	217.
32	163.	167.	172.	177.	183.	190.	198.	206.	215.	224.
33	168.	172.	177.	183.	189.	196.	204.	213.	222.	231.
34	173.	177.	182.	188.	195.	202.	210.	219.	228.	238.
35	179.	183.	188.	194.	201.	208.	217.	226.	235.	245.
36	184.	188.	193.	199.	206.	214.	223.	232.	242.	252.
37	189.	193.	198.	205.	212.	220.	229.	238.	248.	259.
38	194.	198.	204.	210.	218.	226.	235.	245.	255.	266.
39	199.	203.	209.	216.	223.	232.	241.	251.	262.	273.
40	204.	209.	215.	221.	229.	238.	248.	258.	269.	280.

Seismic download or uplift at longitudinal wall (lb/ft), tributary load

Width (ft)	Pitch of the roof									
	3	4	5	6	7	8	9	10	11	12
20	15.	21.	27.	33.	39.	46.	53.	61.	70.	79.
21	16.	22.	28.	34.	41.	48.	56.	64.	73.	82.
22	17.	22.	29.	35.	42.	50.	58.	66.	75.	85.
23	17.	23.	30.	36.	44.	51.	60.	69.	78.	88.
24	18.	24.	31.	38.	45.	53.	62.	71.	81.	91.
25	18.	25.	32.	39.	47.	55.	64.	74.	84.	95.
26	19.	26.	33.	40.	48.	57.	66.	76.	86.	98.
27	19.	26.	34.	41.	50.	59.	68.	78.	89.	101.
28	20.	27.	35.	43.	51.	60.	70.	81.	92.	104.
29	21.	28.	36.	44.	53.	62.	72.	83.	95.	107.
30	21.	29.	37.	45.	54.	64.	75.	86.	98.	110.
31	22.	30.	38.	46.	56.	66.	77.	88.	100.	114.
32	22.	30.	39.	48.	57.	68.	79.	91.	103.	117.
33	23.	31.	40.	49.	59.	69.	81.	93.	106.	120.
34	23.	32.	41.	50.	60.	71.	83.	95.	109.	123.
35	24.	33.	42.	52.	62.	73.	85.	98.	112.	126.
36	25.	33.	43.	53.	63.	75.	87.	100.	114.	130.
37	25.	34.	44.	54.	65.	77.	89.	103.	117.	133.
38	26.	35.	45.	55.	66.	79.	91.	105.	120.	136.
39	26.	36.	46.	57.	68.	80.	94.	108.	123.	139.
40	27.	37.	47.	58.	70.	82.	96.	110.	126.	142.

Download at ridge line is same as Download at longitudinal wall.

Wind download at ridge line is same as wind download at longitudinal wall.

Seismic download or uplift at ridge line is same as at longitudinal wall.

Wind uplift at ridge line (lb/ft), wind load

Pitch of the roof

Width (ft)	3	4	5	6	7	8	9	10	11	12
20	198.	207.	218.	232.	249.	269.	290.	315.	342.	372.
21	207.	217.	229.	244.	262.	282.	305.	331.	359.	390.
22	217.	227.	240.	256.	274.	295.	320.	346.	376.	409.
23	227.	238.	251.	267.	287.	309.	334.	362.	393.	428.
24	237.	248.	262.	279.	299.	322.	349.	378.	411.	446.
25	247.	258.	273.	290.	311.	336.	363.	394.	428.	465.
26	257.	269.	284.	302.	324.	349.	378.	409.	445.	483.
27	267.	279.	295.	314.	336.	363.	392.	425.	462.	502.
28	277.	289.	305.	325.	349.	376.	407.	441.	479.	521.
29	286.	300.	316.	337.	361.	389.	421.	457.	496.	539.
30	296.	310.	327.	349.	374.	403.	436.	472.	513.	558.
31	306.	320.	338.	360.	386.	416.	450.	488.	530.	576.
32	316.	330.	349.	372.	399.	430.	465.	504.	547.	595.
33	326.	341.	360.	383.	411.	443.	479.	520.	564.	613.
34	336.	351.	371.	395.	424.	456.	494.	535.	582.	632.
35	346.	361.	382.	407.	436.	470.	508.	551.	599.	651.
36	356.	372.	393.	418.	448.	483.	523.	567.	616.	669.
37	365.	382.	404.	430.	461.	497.	537.	583.	633.	688.
38	375.	392.	415.	442.	473.	510.	552.	598.	650.	706.
39	385.	403.	425.	453.	486.	524.	566.	614.	667.	725.
40	395.	413.	436.	465.	498.	537.	581.	630.	684.	744.

Wind shear along ridge line is 1/4 the wind shear along the longitudinal wall.

Seismic shear along ridge line is 1/4 the seismic shear along the longitudinal wall.

Distributed wind load along (parallel to) gable line (lb/ft**2), wind load
 Multiply by length of span to obtain wind shear (lb/ft)

Width (ft)	Pitch of the roof									
	3	4	5	6	7	8	9	10	11	12
20	4.55	5.96	7.37	8.77	10.18	11.59	14.27	15.82	17.37	18.92
21	4.53	5.94	7.35	8.76	10.17	11.58	14.25	15.80	17.35	18.90
22	4.52	5.93	7.34	8.75	10.15	11.56	14.24	15.79	17.34	18.89
23	4.51	5.92	7.32	8.73	10.14	11.55	14.23	15.77	17.32	18.87
24	4.50	5.90	7.31	8.72	10.13	11.54	14.21	15.76	17.31	18.86
25	4.49	5.89	7.30	8.71	10.12	11.53	14.20	15.75	17.30	18.85
26	4.47	5.88	7.29	8.70	10.11	11.52	14.19	15.74	17.29	18.84
27	4.47	5.87	7.28	8.69	10.10	11.51	14.18	15.73	17.28	18.83
28	4.46	5.87	7.27	8.68	10.09	11.50	14.17	15.72	17.27	18.82
29	4.45	5.86	7.27	8.67	10.08	11.49	14.17	15.72	17.26	18.81
30	4.44	5.85	7.26	8.67	10.07	11.48	14.16	15.71	17.26	18.81
31	4.43	5.84	7.25	8.66	10.07	11.48	14.15	15.70	17.25	18.80
32	4.43	5.84	7.24	8.65	10.06	11.47	14.15	15.69	17.24	18.79
33	4.42	5.83	7.24	8.65	10.06	11.46	14.14	15.69	17.24	18.79
34	4.42	5.82	7.23	8.64	10.05	11.46	14.13	15.68	17.23	18.78
35	4.41	5.82	7.23	8.64	10.04	11.45	14.13	15.68	17.23	18.78
36	4.41	5.81	7.22	8.63	10.04	11.45	14.12	15.67	17.22	18.77
37	4.40	5.81	7.22	8.63	10.03	11.44	14.12	15.67	17.22	18.77
38	4.40	5.80	7.21	8.62	10.03	11.44	14.11	15.66	17.21	18.76
39	4.39	5.80	7.21	8.62	10.02	11.43	14.11	15.66	17.21	18.76
40	4.39	5.80	7.20	8.61	10.02	11.43	14.11	15.65	17.20	18.75

The panel to panel shear varies linearly from a maximum value at the gable line, to one fourth, (1/4), this maximum value at the midspan of the roof.

To calculate the maximum load in the longitudinal line member due to roof diaphragm bending, multiply the values taken directly from the above table by the length of span squared divided by four, (L*L/4.0).

In the case of no longitudinal line members carrying bending loads: Multiply the values taken directly from the above table by three times length of span squared divided by two times the eave to ridge slope distance, (3.0*L*L/(2.0*H), to calculate the maximum normal stress per panel thickness due to roof diaphragm bending. Multiply values taken directly from the above table by 1.5 times the length of span, (3/2*L), to determine the maximum shear stress due to a parabolic stress distribution.

Distributed seismic load along (parallel to) gable line
(lb/ft**2), tributary load
Multiply by length of span to obtain wind shear (lb/ft)

Width (ft)	Pitch of the roof									
	3	4	5	6	7	8	9	10	11	12
20	5.93	6.04	6.19	6.36	6.56	6.77	7.01	7.27	7.54	7.83
21	5.89	6.00	6.15	6.32	6.52	6.73	6.97	7.23	7.50	7.79
22	5.85	5.97	6.11	6.28	6.48	6.70	6.94	7.19	7.47	7.75
23	5.82	5.94	6.08	6.25	6.45	6.67	6.90	7.16	7.43	7.72
24	5.79	5.91	6.05	6.22	6.42	6.64	6.88	7.13	7.40	7.69
25	5.76	5.88	6.02	6.19	6.39	6.61	6.85	7.10	7.38	7.66
26	5.74	5.85	6.00	6.17	6.37	6.58	6.82	7.08	7.35	7.63
27	5.71	5.83	5.97	6.15	6.34	6.56	6.80	7.05	7.33	7.61
28	5.69	5.81	5.95	6.12	6.32	6.54	6.78	7.03	7.30	7.59
29	5.67	5.79	5.93	6.10	6.30	6.52	6.76	7.01	7.28	7.57
30	5.65	5.77	5.91	6.08	6.28	6.50	6.74	6.99	7.27	7.55
31	5.63	5.75	5.89	6.07	6.26	6.48	6.72	6.98	7.25	7.53
32	5.62	5.73	5.88	6.05	6.25	6.46	6.70	6.96	7.23	7.52
33	5.60	5.72	5.86	6.03	6.23	6.45	6.69	6.94	7.22	7.50
34	5.59	5.70	5.85	6.02	6.22	6.43	6.67	6.93	7.20	7.49
35	5.57	5.69	5.83	6.01	6.20	6.42	6.66	6.91	7.19	7.47
36	5.56	5.68	5.82	5.99	6.19	6.41	6.65	6.90	7.17	7.46
37	5.55	5.66	5.81	5.98	6.18	6.40	6.63	6.89	7.16	7.45
38	5.54	5.65	5.80	5.97	6.16	6.38	6.62	6.88	7.15	7.43
39	5.53	5.64	5.79	5.96	6.15	6.37	6.61	6.87	7.14	7.42
40	5.51	5.63	5.78	5.95	6.14	6.36	6.60	6.86	7.13	7.41

The panel to panel shear varies linearly from a maximum value at the gable line, to one fourth, (1/4), this maximum value at the midspan of the roof.

To calculate the maximum load in the longitudinal line member due to roof diaphragm bending, multiply the values taken directly from the above table by the length of span squared divided by four, (L*L/4.0).

In the case of no longitudinal line members carrying bending loads: Multiply the values taken directly from the above table by three times length of span squared divided by two times the eave to ridge slope distance, (3.0*L*L/(2.0*H), to calculate the maximum normal stress per panel thickness due to roof diaphragm bending. Multiply values taken directly from the above table by 1.5 times the length of span, (3/2*L), to determine the maximum shear stress due to a parabolic stress distribution.

FOLDED PLATE

Distributed load along (parallel to) gable line due to plate action
(lb/ft**2), dead load
Multiply by length of span to obtain shear (lb/ft)

Pitch of the roof

3	4	5	6	7	8	9	10	11	12
20.62	15.81	13.00	11.18	9.92	9.01	8.33	7.81	7.40	7.07

FOLDED PLATE

Distributed load along (parallel to) gable line due to plate action
(lb/ft**2), live load
Multiply by length of span to obtain shear (lb/ft)

Pitch of the roof

3	4	5	6	7	8	9	10	11	12
80.00	60.00	46.43	36.72	29.89	24.87	21.04	18.06	15.68	13.75

The panel to panel shear varies linearly from a maximum value at the gable line, to one fourth, (1/4), this maximum value at the midspan of the roof.

To calculate the maximum load in the longitudinal line member due to roof diaphragm bending, multiply the values taken directly from the above table by the length of span squared divided by four, (L*L/4.0).

In the case of no longitudinal line members carrying bending loads: Multiply the values taken directly from the above table by three times length of span squared divided by two times the eave to ridge slope distance, (3.0*L*L/(2.0*H), to calculate the maximum normal stress per panel thickness due to roof diaphragm bending. Multiply values taken directly from the above table by 1.5 times the length of span, (3/2*L), to determine the maximum shear stress due to a parabolic stress distribution.

FOLDED PLATE

Distributed wind load along (parallel to) gable line (lb/ft**2), wind load
 Negative sign denotes loads opposite those imposed from dead and live loads
 Multiply by length of span to obtain wind shear (lb/ft)

Pitch of the roof

	3	4	5	6	7	8	9	10	11	12
20	-53.56	-39.76	-31.36	-25.67	-21.53	-18.35	-17.65	-18.86	-20.13	-21.45
21	-53.54	-39.74	-31.35	-25.66	-21.52	-18.34	-17.63	-18.84	-20.12	-21.43
22	-53.53	-39.73	-31.34	-25.65	-21.50	-18.32	-17.62	-18.83	-20.10	-21.42
23	-53.52	-39.72	-31.32	-25.63	-21.49	-18.31	-17.61	-18.82	-20.09	-21.41
24	-53.51	-39.70	-31.31	-25.62	-21.48	-18.30	-17.59	-18.80	-20.08	-21.40
25	-53.49	-39.69	-31.30	-25.61	-21.47	-18.29	-17.58	-18.79	-20.07	-21.39
26	-53.48	-39.68	-31.29	-25.60	-21.46	-18.28	-17.57	-18.78	-20.06	-21.38
27	-53.48	-39.67	-31.28	-25.59	-21.45	-18.27	-17.56	-18.77	-20.05	-21.37
28	-53.47	-39.67	-31.27	-25.58	-21.44	-18.26	-17.55	-18.77	-20.04	-21.36
29	-53.46	-39.66	-31.26	-25.57	-21.43	-18.25	-17.55	-18.76	-20.03	-21.35
30	-53.45	-39.65	-31.26	-25.57	-21.42	-18.24	-17.54	-18.75	-20.02	-21.34
31	-53.44	-39.64	-31.25	-25.56	-21.42	-18.24	-17.53	-18.74	-20.02	-21.33
32	-53.44	-39.64	-31.24	-25.55	-21.41	-18.23	-17.53	-18.74	-20.01	-21.33
33	-53.43	-39.63	-31.24	-25.55	-21.40	-18.22	-17.52	-18.73	-20.00	-21.32
34	-53.43	-39.62	-31.23	-25.54	-21.40	-18.22	-17.51	-18.72	-20.00	-21.32
35	-53.42	-39.62	-31.23	-25.54	-21.39	-18.21	-17.51	-18.72	-19.99	-21.31
36	-53.42	-39.61	-31.22	-25.53	-21.39	-18.21	-17.50	-18.71	-19.99	-21.31
37	-53.41	-39.61	-31.22	-25.53	-21.38	-18.20	-17.50	-18.71	-19.98	-21.30
38	-53.41	-39.60	-31.21	-25.52	-21.38	-18.20	-17.49	-18.70	-19.98	-21.30
39	-53.40	-39.60	-31.21	-25.52	-21.37	-18.19	-17.49	-18.70	-19.97	-21.29
40	-53.40	-39.60	-31.20	-25.51	-21.37	-18.19	-17.49	-18.70	-19.97	-21.29

FOLDED PLATE

Distributed wind load along (parallel to) gable line (lb/ft**2), wind load
 Multiply by length of span to obtain wind shear (lb/ft)

Pitch of the roof

	3	4	5	6	7	8	9	10	11	12
20	53.56	39.76	31.36	25.67	21.53	18.35	17.65	18.86	20.13	21.45
21	53.54	39.74	31.35	25.66	21.52	18.34	17.63	18.84	20.12	21.43
22	53.53	39.73	31.34	25.65	21.50	18.32	17.62	18.83	20.10	21.42
23	53.52	39.72	31.32	25.63	21.49	18.31	17.61	18.82	20.09	21.41
24	53.51	39.70	31.31	25.62	21.48	18.30	17.59	18.80	20.08	21.40
25	53.49	39.69	31.30	25.61	21.47	18.29	17.58	18.79	20.07	21.39
26	53.48	39.68	31.29	25.60	21.46	18.28	17.57	18.78	20.06	21.38
27	53.48	39.67	31.28	25.59	21.45	18.27	17.56	18.77	20.05	21.37
28	53.47	39.67	31.27	25.58	21.44	18.26	17.55	18.77	20.04	21.36
29	53.46	39.66	31.26	25.57	21.43	18.25	17.55	18.76	20.03	21.35
30	53.45	39.65	31.26	25.57	21.42	18.24	17.54	18.75	20.02	21.34
31	53.44	39.64	31.25	25.56	21.42	18.24	17.53	18.74	20.02	21.33
32	53.44	39.64	31.24	25.55	21.41	18.23	17.53	18.74	20.01	21.33
33	53.43	39.63	31.24	25.55	21.40	18.22	17.52	18.73	20.00	21.32
34	53.43	39.62	31.23	25.54	21.40	18.22	17.51	18.72	20.00	21.32
35	53.42	39.62	31.23	25.54	21.39	18.21	17.51	18.72	19.99	21.31
36	53.42	39.61	31.22	25.53	21.39	18.21	17.50	18.71	19.99	21.31
37	53.41	39.61	31.22	25.53	21.38	18.20	17.50	18.71	19.98	21.30
38	53.41	39.60	31.21	25.52	21.38	18.20	17.49	18.70	19.98	21.30
39	53.40	39.60	31.21	25.52	21.37	18.19	17.49	18.70	19.97	21.29
40	53.40	39.60	31.20	25.51	21.37	18.19	17.49	18.70	19.97	21.29

Appendix E

Program Comb.f Hard Copy

Program *comb.f* combines the separated load effects according to UBC '88 specifications. The live, dead, wind and seismic loads and their respective parameters are interactively input, and the resulting load tables for varying pitch, gable to gable length, and eave to eave width are calculated.

```
67      print*, ' To continue, enter any letter.'
68      read*, z
69      write(1,1850)
70      c
71      c      Calculate various tables
72      c
73      write(1,*)'          Download at longitudinal wall (lb
74      +/ft)'
75      write(1,*)' '
76      write(1,*)'          Pitch of the roof'
77      write(1,*)' '
78      write(1,*)' Width   3       4       5       6       7       8       9
79      + 10   11   12'
80      write(1,*)' (ft) '
81      print*, '          Download at longitudinal wall (lb
82      +/ft)'
83      print*, ' '
84      print*, '          Pitch of the roof'
85      print*, ' '
86      print*, ' Width   3       4       5       6       7       8       9
87      + 10   11   12'
88      print*, ' (ft) '
89      do 500 iw=20, 40, 1
90      j=0
91      do 50 p=3, 12, 1
92      if(wli.gt.20.0.and.p.gt.4)then
93      wl=wli-(atan(real(p)/12.0)
94      +      *45.0/atan(1.0)-20.0)*(wli/40.0-0.5)
95      else
96      wl=wli
97      endif
98      pip=p/12.0
99      rad=atan(pip)
100     h=real(iw)/(2.0*cos(rad))
101     j=j+1
102     a10=iw*wd/(4.0*cos(rad))
103     a11=real(iw)*wl/(4.0)
104     if(p.lt.9)then
105     a12=0.0
106     else
107     a12=wpr*0.8*h/(cos(rad)*2.0)
108     endif
109     a18=0.75*zone*tan(rad)*(wde*h/2.0+wwall*d1/2.0)
110     dl=a10+a11
111     dw=0.75*(a10+a12)
112     dwl2=0.75*(a10+a12+a11/2.0)
113     dlw2=0.75*(a10+a11+a12/2.0)
114     if(plan.eq.'y')then
115     dls=a10+a11+a18
116     else
117     dls=0.75*(a10+a11+a18)
118     endif
119     if(dl.gt.dw.and.dl.gt.dwl2.and.dl.gt.dlw2.and.dl.gt.dls)
120     +then
121     a(j)=dl
122     elseif(dw.gt.dwl2.and.dw.gt.dlw2.and.dw.gt.dls)then
123     a(j)=dw
124     elseif(dwl2.gt.dlw2.and.dwl2.gt.dls)then
125     a(j)=dwl2
126     elseif(dlw2.gt.dls)then
127     a(j)=dlw2
128     else
129     a(j)=dls
130     endif
131     50 continue
132     write(1,1750) iw,a(1),a(2),a(3),a(4),a(5),a(6),a(7),a(8),a(9)
```



```
463         if(wli.gt.20.0.and.p.gt.4)then
464             wl=wli-(atan(real(p)/12.0)
465 +             *45.0/atan(1.0)-20.0)*(wli/40.0-0.5)
466         else
467             wl=wli
468         endif
469         pip=p/12.0
470         rad=atan(pip)
471         j=j+1
472         a36=0.55*0.75*zone*(wde/cos(rad)+d1*wwall/real(iw))
473         a40=wd/(2.0*sin(rad))
474         a41=wl*cos(rad)/(2.0*sin(rad))
475         if(p.lt.9)then
476             cq=0.3
477         else
478             cq=0.4
479         endif
480         b1=(0.65*d1/real(iw)+(cq+0.7)/2.0*wpr*tan(rad)+
481 + (0.7-cq)/2.0*wpr*cos(rad)/(2.0*sin(rad)))
482         if(p.lt.9)then
483             cq=0.9
484         else
485             cq=0.7
486         endif
487         b2=(0.65*d1/real(iw)+(-cq+0.7)/2.0*wpr*tan(rad)+
488 + (0.7+cq)/2.0*wpr*cos(rad)/(2.0*sin(rad)))
489         b3=(0.65*d1/real(iw)+0.7*wpr*cos(rad)/(2.0*sin(rad)))
490         if(b1.gt.b2.and.b1.gt.b3)then
491             a44=b1
492         elseif(b2.gt.b3)then
493             a44=b2
494         else
495             a44=b3
496         endif
497         if(p.lt.9)then
498             cq=0.3
499         else
500             cq=0.4
501         endif
502         b1=(0.65*d1/real(iw)+cq*wpr*tan(rad)+
503 + (cq)/2.0*wpr*cos(rad)/(2.0*sin(rad)))
504         b2=(0.65*d1/real(iw)+(cq+0.7)/2.0*wpr*tan(rad)+
505 + (0.7-cq)/2.0*wpr*cos(rad)/(2.0*sin(rad)))
506         if(p.lt.9)then
507             cq=0.9
508         else
509             cq=0.7
510         endif
511         b3=(0.65*d1/real(iw)+(-cq+0.7)/2.0*wpr*tan(rad)+
512 + (0.7+cq)/2.0*wpr*cos(rad)/(2.0*sin(rad)))
513         if(b1.gt.b2.and.b1.gt.b3)then
514             a45=b1
515         elseif(b2.gt.b3)then
516             a45=b2
517         else
518             a45=b3
519         endif
520         dl=a40+a41
521         dw=0.75*(a44-a40)
522         dwl2=0.75*(a40+a45+a41/2.0)
523         dlw2=0.75*(a40+a41+a45/2.0)
524         if(plan.eq.'y')then
525             dls=a40+a41+a36
526         else
527             dls=0.75*(a40+a41+a36)
528         endif
```

```
529         if(dl.gt.dw.and.dl.gt.dwl2.and.dl.gt.dlw2.and.dl.gt.dls)
530 +then
531             a(j)=dl
532         elseif(dw.gt.dwl2.and.dw.gt.dlw2.and.dw.gt.dls)then
533             a(j)=dw
534         elseif(dwl2.gt.dlw2.and.dwl2.gt.dls)then
535             a(j)=dwl2
536         elseif(dlw2.gt.dls)then
537             a(j)=dlw2
538         else
539             a(j)=dls
540         endif
541 56         continue
542             write(1,1700) iw,a(1),a(2),a(3),a(4),a(5),a(6),a(7),a(8),a(9)
543 +,a(10)
544             write(*,1700) iw,a(1),a(2),a(3),a(4),a(5),a(6),a(7),a(8),a(9)
545 +,a(10)
546 506         continue
547             write(1,*)' '
548             write(1,*)' '
549             write(1,*)' The panel to panel shear varies linearly from a maximum
550 +m value'
551             write(1,*)' at the gable line, to one fourth, (1/4), this maximum
552 +value at'
553             write(1,*)' the midspan of the roof.'
554             write(1,*)' '
555             write(1,*)' To calculate the maximum load in the longitudinal line
556 + member'
557             write(1,*)' due to roof diaphragm bending, multiply the values tak
558 +en'
559             write(1,*)' directly from the above table by the length of span sq
560 +uared'
561             write(1,*)' divided by four, (L*L/4.0).'
562             write(1,*)' '
563             write(1,*)' In the case of no longitudinal line members carrying b
564 +ending loads:'
565             write(1,*)' Multiply the values taken directly from the above tabl
566 +e by'
567             write(1,*)' three times length of span squared divided by two time
568 +s the eave to ridge'
569             write(1,*)' slope distance, (3.0*L*L/(2.0*H), to calculate the max
570 +imum normal stress'
571             write(1,*)' per panel thickness due to roof diaphragm bending.'
572             write(1,*)' Multiply values taken directly from the above table by
573 +
574             write(1,*)' 1.5 times the length of span, (3/2*L), to determine th
575 +e maximum shear'
576             write(1,*)' stress due to a parabolic stress distribution.'
577 1700 format(5x, i2, 1x, 10(1x, f6.2))
578 1750 format(5x, i2, 1x, 10(1x, f6.0))
579 1800 format(5x, i2, 2x, f6.0)
580 1850 format('1')
581 1900 format(8x, 10(1x, f6.2))
582         end
```

E.1 Comb.f Output

The standard load case parameters established in Chapter 6 are input into program.

This program calculates the most critical effect from the combination of dead, live, wind, and seismic loads, given the following parameters:

Seismic zone factor = 0.400000
Live load per horizontal projected area of roof = 40.0000 (p.s.f.).
Dead load of the roof = 10.0000 (p.s.f.).
Live load per horizontal projected area of roof in a
earthquake = 30.0000 (p.s.f.).
Dead load of the wall element = 10.0000 (p.s.f.).
Height of attaching wall height element = 10.0000 (ft.).
Wind stagnation pressure at standard height of 30 feet = 26.0000
(p.s.f.).
Combined height, exposure and gust factor coefficient 1.30000
There is no plan irregularity of type A,B,C, or D

Download at longitudinal wall (lb/ft)

Width (ft)	Pitch of the roof									
	3	4	5	6	7	8	9	10	11	12
20	252.	253.	248.	239.	232.	226.	264.	277.	291.	307.
21	264.	265.	260.	251.	244.	237.	278.	291.	306.	323.
22	277.	278.	272.	263.	255.	248.	291.	305.	321.	338.
23	289.	291.	285.	275.	267.	260.	304.	319.	335.	354.
24	302.	303.	297.	287.	279.	271.	317.	332.	350.	369.
25	314.	316.	310.	299.	290.	282.	331.	346.	364.	384.
26	327.	329.	322.	311.	302.	294.	344.	360.	379.	400.
27	340.	341.	334.	323.	314.	305.	357.	374.	393.	415.
28	352.	354.	347.	335.	325.	316.	370.	388.	408.	430.
29	365.	366.	359.	347.	337.	328.	384.	402.	422.	446.
30	377.	379.	371.	359.	348.	339.	397.	416.	437.	461.
31	390.	392.	384.	371.	360.	350.	410.	429.	452.	476.
32	402.	404.	396.	383.	372.	361.	423.	443.	466.	492.
33	415.	417.	409.	395.	383.	373.	436.	457.	481.	507.
34	428.	430.	421.	407.	395.	384.	450.	471.	495.	523.
35	440.	442.	433.	419.	406.	395.	463.	485.	510.	538.
36	453.	455.	446.	431.	418.	407.	476.	499.	524.	553.
37	465.	468.	458.	443.	430.	418.	489.	513.	539.	569.
38	478.	480.	470.	455.	441.	429.	503.	526.	554.	584.
39	491.	493.	483.	467.	453.	440.	516.	540.	568.	599.
40	503.	505.	495.	479.	464.	452.	529.	554.	583.	615.

Uplift at longitudinal wall (lb/ft)

Width (ft)	Pitch of the roof									
	3	4	5	6	7	8	9	10	11	12
20	109.	115.	123.	132.	143.	156.	171.	187.	206.	226.
21	115.	121.	129.	139.	151.	164.	180.	197.	216.	237.
22	120.	127.	135.	146.	158.	172.	188.	206.	226.	248.
23	126.	133.	141.	152.	165.	180.	197.	216.	237.	260.
24	131.	138.	148.	159.	172.	188.	205.	225.	247.	271.
25	137.	144.	154.	165.	179.	195.	214.	234.	257.	282.
26	142.	150.	160.	172.	186.	203.	222.	244.	267.	294.
27	148.	156.	166.	179.	194.	211.	231.	253.	278.	305.
28	153.	162.	172.	185.	201.	219.	239.	262.	288.	316.
29	159.	167.	178.	192.	208.	227.	248.	272.	298.	327.
30	164.	173.	185.	199.	215.	234.	256.	281.	309.	339.
31	170.	179.	191.	205.	222.	242.	265.	291.	319.	350.
32	175.	185.	197.	212.	230.	250.	274.	300.	329.	361.
33	181.	190.	203.	218.	237.	258.	282.	309.	339.	373.
34	186.	196.	209.	225.	244.	266.	291.	319.	350.	384.
35	192.	202.	215.	232.	251.	274.	299.	328.	360.	395.
36	197.	208.	221.	238.	258.	281.	308.	337.	370.	406.
37	203.	213.	228.	245.	265.	289.	316.	347.	381.	418.
38	208.	219.	234.	251.	273.	297.	325.	356.	391.	429.
39	213.	225.	240.	258.	280.	305.	333.	365.	401.	440.
40	219.	231.	246.	265.	287.	313.	342.	375.	411.	452.

Load along (parallel to) longitudinal wall (lb)
Divide by the length of span to obtain shear (lb/ft)

Width (ft)	Pitch of the roof									
	3	4	5	6	7	8	9	10	11	12
20	2047.	2169.	2281.	2385.	2478.	2562.	2636.	2703.	2761.	2813.
21	2171.	2305.	2429.	2543.	2645.	2738.	2820.	2893.	2958.	3015.
22	2296.	2443.	2579.	2704.	2817.	2918.	3009.	3089.	3160.	3222.
23	2423.	2584.	2733.	2869.	2993.	3104.	3202.	3290.	3367.	3436.
24	2553.	2728.	2890.	3038.	3173.	3293.	3401.	3496.	3581.	3655.
25	2684.	2874.	3050.	3211.	3357.	3488.	3604.	3708.	3799.	3880.
26	2817.	3023.	3213.	3387.	3545.	3687.	3813.	3925.	4024.	4111.
27	2953.	3174.	3379.	3567.	3738.	3890.	4026.	4147.	4254.	4348.
28	3090.	3328.	3549.	3751.	3934.	4098.	4245.	4374.	4489.	4591.
29	3229.	3485.	3722.	3939.	4135.	4311.	4468.	4607.	4730.	4839.
30	3371.	3644.	3898.	4130.	4340.	4528.	4696.	4845.	4977.	5093.
31	3514.	3806.	4077.	4324.	4549.	4750.	4929.	5088.	5229.	5353.
32	3659.	3970.	4259.	4523.	4762.	4976.	5167.	5337.	5487.	5619.
33	3807.	4137.	4444.	4725.	4979.	5207.	5410.	5591.	5750.	5891.
34	3956.	4307.	4633.	4931.	5201.	5443.	5658.	5850.	6019.	6168.
35	4107.	4479.	4824.	5140.	5426.	5683.	5911.	6114.	6293.	6452.
36	4261.	4654.	5019.	5353.	5656.	5927.	6169.	6384.	6573.	6741.
37	4416.	4832.	5217.	5570.	5890.	6177.	6432.	6659.	6859.	7036.
38	4573.	5012.	5419.	5791.	6128.	6430.	6700.	6939.	7150.	7337.
39	4733.	5194.	5623.	6015.	6370.	6689.	6972.	7224.	7447.	7644.
40	4894.	5380.	5831.	6243.	6617.	6952.	7250.	7515.	7749.	7956.

Shear along ridge line is 1/4 the wind shear along the longitudinal wall.

Download at ridge line is same as Download at longitudinal wall.

Uplift at ridge line (lb/ft)

Pitch of the roof

Width (ft)	3	4	5	6	7	8	9	10	11	12
20	42.	49.	58.	68.	81.	95.	112.	130.	151.	173.
21	49.	57.	66.	77.	90.	105.	123.	142.	163.	187.
22	57.	64.	74.	86.	99.	115.	134.	154.	176.	201.
23	64.	72.	82.	94.	109.	126.	144.	166.	189.	215.
24	72.	80.	90.	103.	118.	136.	155.	177.	202.	229.
25	79.	88.	98.	112.	128.	146.	166.	189.	215.	242.
26	87.	95.	107.	120.	137.	156.	177.	201.	227.	256.
27	94.	103.	115.	129.	146.	166.	188.	213.	240.	270.
28	101.	111.	123.	138.	156.	176.	199.	225.	253.	284.
29	109.	119.	131.	147.	165.	186.	210.	236.	266.	298.
30	116.	126.	139.	155.	174.	196.	221.	248.	279.	312.
31	124.	134.	148.	164.	184.	206.	232.	260.	292.	326.
32	131.	142.	156.	173.	193.	216.	242.	272.	304.	340.
33	138.	150.	164.	181.	202.	226.	253.	284.	317.	354.
34	146.	157.	172.	190.	212.	236.	264.	296.	330.	368.
35	153.	165.	180.	199.	221.	246.	275.	307.	343.	382.
36	161.	173.	188.	208.	230.	256.	286.	319.	356.	396.
37	168.	181.	197.	216.	240.	267.	297.	331.	369.	410.
38	175.	188.	205.	225.	249.	277.	308.	343.	381.	424.
39	183.	196.	213.	234.	258.	287.	319.	355.	394.	438.
40	190.	204.	221.	242.	268.	297.	330.	366.	407.	452.

Uplift at rake (upward) (lb/ft)

Width (ft)	Pitch of the roof									
	3	4	5	6	7	8	9	10	11	12
20	126.	126.	126.	125.	125.	124.	123.	122.	122.	121.
21	133.	132.	132.	131.	131.	130.	129.	129.	128.	127.
22	139.	139.	138.	138.	137.	136.	136.	135.	134.	133.
23	145.	145.	145.	144.	143.	143.	142.	141.	140.	139.
24	152.	151.	151.	150.	150.	149.	148.	147.	146.	145.
25	158.	158.	157.	156.	156.	155.	154.	153.	152.	151.
26	164.	164.	163.	163.	162.	161.	160.	159.	158.	157.
27	171.	170.	170.	169.	168.	167.	166.	165.	164.	163.
28	177.	177.	176.	175.	174.	174.	172.	171.	170.	169.
29	183.	183.	182.	182.	181.	180.	179.	178.	176.	175.
30	190.	189.	189.	188.	187.	186.	185.	184.	182.	181.
31	196.	196.	195.	194.	193.	192.	191.	190.	188.	187.
32	202.	202.	201.	200.	199.	198.	197.	196.	195.	193.
33	209.	208.	207.	207.	206.	204.	203.	202.	201.	199.
34	215.	214.	214.	213.	212.	211.	209.	208.	207.	205.
35	221.	221.	220.	219.	218.	217.	216.	214.	213.	211.
36	228.	227.	226.	225.	224.	223.	222.	220.	219.	217.
37	234.	233.	233.	232.	230.	229.	228.	227.	225.	223.
38	240.	240.	239.	238.	237.	235.	234.	233.	231.	229.
39	247.	246.	245.	244.	243.	242.	240.	239.	237.	235.
40	253.	252.	251.	250.	249.	248.	246.	245.	243.	241.

RIDGE BEAM
Distributed load along (parallel to) gable line (lb/ft**2)
Multiply by length of span to obtain shear (lb/ft)

Width (ft)	Pitch of the roof									
	3	4	5	6	7	8	9	10	11	12
20	4.45	4.53	5.52	6.58	7.64	8.69	10.70	11.86	13.02	14.19
21	4.42	4.50	5.51	6.57	7.63	8.68	10.69	11.85	13.01	14.17
22	4.39	4.48	5.50	6.56	7.62	8.67	10.68	11.84	13.00	14.16
23	4.36	4.45	5.49	6.55	7.61	8.66	10.67	11.83	12.99	14.15
24	4.34	4.43	5.48	6.54	7.60	8.65	10.66	11.82	12.98	14.15
25	4.32	4.42	5.48	6.53	7.59	8.65	10.65	11.81	12.98	14.14
26	4.30	4.41	5.47	6.53	7.58	8.64	10.64	11.81	12.97	14.13
27	4.29	4.41	5.46	6.52	7.57	8.63	10.64	11.80	12.96	14.12
28	4.27	4.40	5.46	6.51	7.57	8.62	10.63	11.79	12.95	14.12
29	4.25	4.39	5.45	6.51	7.56	8.62	10.62	11.79	12.95	14.11
30	4.24	4.39	5.44	6.50	7.56	8.61	10.62	11.78	12.94	14.11
31	4.23	4.38	5.44	6.49	7.55	8.61	10.61	11.78	12.94	14.10
32	4.21	4.38	5.43	6.49	7.55	8.60	10.61	11.77	12.93	14.09
33	4.20	4.37	5.43	6.49	7.54	8.60	10.60	11.77	12.93	14.09
34	4.19	4.37	5.42	6.48	7.54	8.59	10.60	11.76	12.92	14.09
35	4.18	4.36	5.42	6.48	7.53	8.59	10.60	11.76	12.92	14.08
36	4.17	4.36	5.42	6.47	7.53	8.59	10.59	11.75	12.92	14.08
37	4.16	4.36	5.41	6.47	7.53	8.58	10.59	11.75	12.91	14.07
38	4.15	4.35	5.41	6.47	7.52	8.58	10.59	11.75	12.91	14.07
39	4.14	4.35	5.41	6.46	7.52	8.57	10.58	11.74	12.91	14.07
40	4.14	4.35	5.40	6.46	7.52	8.57	10.58	11.74	12.90	14.06

The panel to panel shear varies linearly from a maximum value at the gable line, to one fourth, (1/4), this maximum value at the midspan of the roof.

To calculate the maximum load in the longitudinal line member due to roof diaphragm bending, multiply the values taken directly from the above table by the length of span squared divided by four, (L*L/4.0).

In the case of no longitudinal line members carrying bending loads: Multiply the values taken directly from the above table by three times length of span squared divided by two times the eave to ridge slope distance, (3.0*L*L/(2.0*H), to calculate the maximum normal stress per panel thickness due to roof diaphragm bending. Multiply values taken directly from the above table by 1.5 times the length of span, (3/2*L), to determine the maximum shear stress due to a parabolic stress distribution.

FOLDED PLATE
 Distributed load along (parallel to) gable line (lb/ft**2)
 Multiply by length of span to obtain shear (lb/ft)

Width (ft)	Pitch of the roof									
	3	4	5	6	7	8	9	10	11	12
20	100.62	75.81	59.43	47.90	39.81	33.88	29.38	26.77	26.53	26.55
21	100.62	75.81	59.43	47.90	39.81	33.88	29.38	26.76	26.52	26.54
22	100.62	75.81	59.43	47.90	39.81	33.88	29.38	26.75	26.51	26.52
23	100.62	75.81	59.43	47.90	39.81	33.88	29.38	26.74	26.50	26.52
24	100.62	75.81	59.43	47.90	39.81	33.88	29.38	26.73	26.49	26.51
25	100.62	75.81	59.43	47.90	39.81	33.88	29.38	26.72	26.48	26.50
26	100.62	75.81	59.43	47.90	39.81	33.88	29.38	26.72	26.47	26.49
27	100.62	75.81	59.43	47.90	39.81	33.88	29.38	26.71	26.46	26.48
28	100.62	75.81	59.43	47.90	39.81	33.88	29.38	26.70	26.46	26.48
29	100.62	75.81	59.43	47.90	39.81	33.88	29.38	26.70	26.45	26.47
30	100.62	75.81	59.43	47.90	39.81	33.88	29.38	26.69	26.45	26.47
31	100.62	75.81	59.43	47.90	39.81	33.88	29.38	26.69	26.44	26.46
32	100.62	75.81	59.43	47.90	39.81	33.88	29.38	26.68	26.44	26.46
33	100.62	75.81	59.43	47.90	39.81	33.88	29.38	26.68	26.43	26.45
34	100.62	75.81	59.43	47.90	39.81	33.88	29.38	26.67	26.43	26.45
35	100.62	75.81	59.43	47.90	39.81	33.88	29.38	26.67	26.42	26.44
36	100.62	75.81	59.43	47.90	39.81	33.88	29.38	26.67	26.42	26.44
37	100.62	75.81	59.43	47.90	39.81	33.88	29.38	26.66	26.42	26.44
38	100.62	75.81	59.43	47.90	39.81	33.88	29.38	26.66	26.41	26.43
39	100.62	75.81	59.43	47.90	39.81	33.88	29.38	26.65	26.41	26.43
40	100.62	75.81	59.43	47.90	39.81	33.88	29.38	26.65	26.41	26.43

The panel to panel shear varies linearly from a maximum value at the gable line, to one fourth, (1/4), this maximum value at the midspan of the roof.

To calculate the maximum load in the longitudinal line member due to roof diaphragm bending, multiply the values taken directly from the above table by the length of span squared divided by four, (L*L/4.0).

In the case of no longitudinal line members carrying bending loads: Multiply the values taken directly from the above table by three times length of span squared divided by two times the eave to ridge slope distance, (3.0*L*L/(2.0*H), to calculate the maximum normal stress per panel thickness due to roof diaphragm bending. Multiply values taken directly from the above table by 1.5 times the length of span, (3/2*L), to determine the maximum shear stress due to a parabolic stress distribution.

References

- [A.G.S., 70] Ramsey & Sleeper.
Architectural Graphic Standards.
John Wiley & Sons, 1970.
- [A.I.S.C., 87] American Institute of Steel Construction.
Manual of Steel Construction.
American Institute of Steel Construction, Inc., 1987.
- [A.I.S.I., 83] American Iron and Steel Institute.
Specification for the Design of Cold-Formed Steel Structural Members.
American Iron and Steel Institute, Inc., 1983.
- [A.I.T.C., 85] American Institute of Timber Construction.
Timber Construction Manual.
John Wiley & Sons, 1985.
- [Allen, 69] Allen, Howard G.
Analysis and Design of Structural Sandwich Panels.
Pergamon Press, 1969.
- [Benjamin, 82] Benjamin, B. S.
Structural Design with Plastics.
Van Nostrand Reinhold Company, 1982.
- [Bijlaard, 69] Bijlaard, P. P.
Thermal Deformations and Stresses in Rectangular Sandwich Plates.
Journal of the Aero/Space Sciences, April, 1969.
- [Carney, 71] Carney, J. M.
Plywood Folded Plates: Design and Details.
Technical Report 121, American Plywood Association, 1971.
- [Davies, 87] Davies, J. M.
Design Criteria for Structural Sandwich Panels.
The Structural Engineer 12, 1987.
- [Ericksen, 58] Ericksen, W. S.
Effects of shear deformation in the core of flat rectangular sandwich panel.
Technical Report, Forest Products Laboratory Report 1583-D, 1958.
- [March, 55] March, H. W.
Effects of shear deformation in the core of flat rectangular sandwich panel.
Technical Report, Forest Products Laboratory Report 1583, 1955.
- [Pogorzelski, 69] Pogorzelski, Jerzy.
Thermal Deformations and Stresses in Rectangular Sandwich Panels
with Non-Rigid Cores.
Building Science 4, 1969.

- [Reissner, 49] Reissner, E.
Small bending and stretching of sandwich type shells.
Technical Report 1832, N.A.C.A. Technical Note, 1949.
- [Structural Plastics Design Manual, 84]
American Society of Civil Engineers.
Structural Plastics Design Manual.
American Society of Civil Engineers, 1984.
- [Sweet's Catalog File, 88]
Sweets Division.
Sweet's Catalog File: General Building and Renovation.
McGraw-Hill Information Systems, 1988.
- [Timoshenko et al., 59]
Timoshenko, S. and Woinowsky-Krieger, S.
Theory of Plates and Shells.
McGraw-Hill Book Company, Inc., 1959.
- [U.B.C. Standards, 88]
U.B.C.
Uniform Building Code Standards.
, 1988.
- [U.B.C., 88] U.B.C.
Uniform Building Code .
, 1988.
- [Winter, 47] Winter, G. and Pei, M.
Hipped Plate Construction.
American Concrete Inst. 43:505-532, January, 1947.
- [Yu, 85] Yu, Wei-Wen.
Cold-Formed Steel.
John Wiley & Sons, 1985.