

"THEORY AND APPLICATION OF DEFENSIVE STRATEGY"

by

John R. Hauser

Massachusetts Institute of Technology

Paper prepared for the Dean Symposium in Applied Economics

Columbia University

M.I.T. Working Paper No. 1642-85

September 1984

ABSTRACT

For every new product launched, there are many major existing firms who wish to defend their product's profitability from the new product attack. This essay summarizes research on defensive marketing strategy, that is, the adjustment of price, advertising, image, ingredients, distribution and other marketing mix elements in order to maintain maximum profitability and strategic position.

First, a marketing science model of consumer behavior is presented and interpreted relative to an applied economics perspective. This model implies qualitative results which suggest directional changes in price, advertising, product ingredients, and distribution. Next, measurement and estimation of the consumer model are discussed and an empirical application presented. Included are vignettes on seven world-wide applications.

The focus throughout this essay is on the strengths and weaknesses of the research and applications to date and on the opportunities for further research by both applied economists and marketing scientists.

1. PERSPECTIVE

My perspective is that of a marketing scientist. My goal is to study marketing phenomena and to develop theory and methodology which helps managers better understand the environment in which they operate in order to use marketing strategies proactively to maximize profit. The research summarized in this essay is defensive strategy, or more simply, how to achieve the best profit position when a competitive new product enters a market in which a defending firm now has a profitable product.

This problem is perceived as critically important to a large group of marketing managers, division managers, and CEO's. Each year, over 1,000 new products are launched in the consumer sector and many times that number in the industrial sector. Many are minor innovations of little impact, but significant numbers are threats to highly profitable businesses.

For example, consider the new analgesic products, Advil (American Home Products) and Nuprin (Bristol-Myers), based on the drug ibuprofen which became available over-the-counter in May, 1984. Both entries have the potential to impact substantially the dominant share and profitability of Johnson & Johnson's Tylenol brand, which is based on another drug, acetaminophen. (The analgesic category accounts for almost \$1.5 billion in annual sales.) Johnson & Johnson can counter with changes in price, coupons, price-off deals, advertising budgets, advertising message, in-store promotions, trade deals, sales calls on doctors, new acetaminophen products, or even a new ibuprofen brand when it comes off patent next year. But which combination of these marketing strategies is most effective and what level of investment (disinvestment) in each strategy will lead to maximum (after attack) profit? Or, as a brand manager once told me, "Should we bomb them back to the stone ages or just hope they'll go away?"

In the past four years, we have made some initial progress in addressing this problem. This progress is summarized in three published papers (Hauser and Simmie, 1981; Hauser and Shugan, 1983; and Hauser and Gaskin, 1984) as well as seven confidential applications in the U. S. and Japan. I hope in this essay to give you an overview of what we have learned about the problem. In doing so, you will also see what we do not know and would like to understand. Because our perspective is marketing science, I believe we bring unique strengths to the study of this problem. I also believe that, as applied economists, your unique strengths will add new insight and new approaches to the study of defensive strategy.

2. CONSUMER MODEL

The theory upon which defensive marketing strategy is based is an analytic model of how consumers respond to marketing strategies. This model has evolved based on over fifteen years of empirical and theoretical research in marketing science. Each assumption is based firmly on empirically documented generalizations of consumer behavior. While it is used here for defensive strategy, it applies also to many other strategic issues. You will recognize many components as quite similar to economic models of consumer behavior. However, there are other components with which you may be uncomfortable. Because our goal is marketing science, we have chosen initially to stress certain phenomena that are relevant to marketing decisions. As our knowledge advances, we will add richness in other phenomena.

In this section, I present the intuition behind each assumption. The formal mathematics are in Hauser and Shugan (1983).

Product Image. It is common in marketing practice and theory to represent products by how consumers perceive them in a multidimensional space. For example, Figure 1 is a representation of brand images in the

analgesics market, circa early-1970's. In this "perceptual map", Tylenol has a unique "position" because consumers perceive it to have fewer side effects, such as stomach upset, than the aspirin-based products, Bayer, Anacin, and Excedrin. A number of comments about the map are relevant.

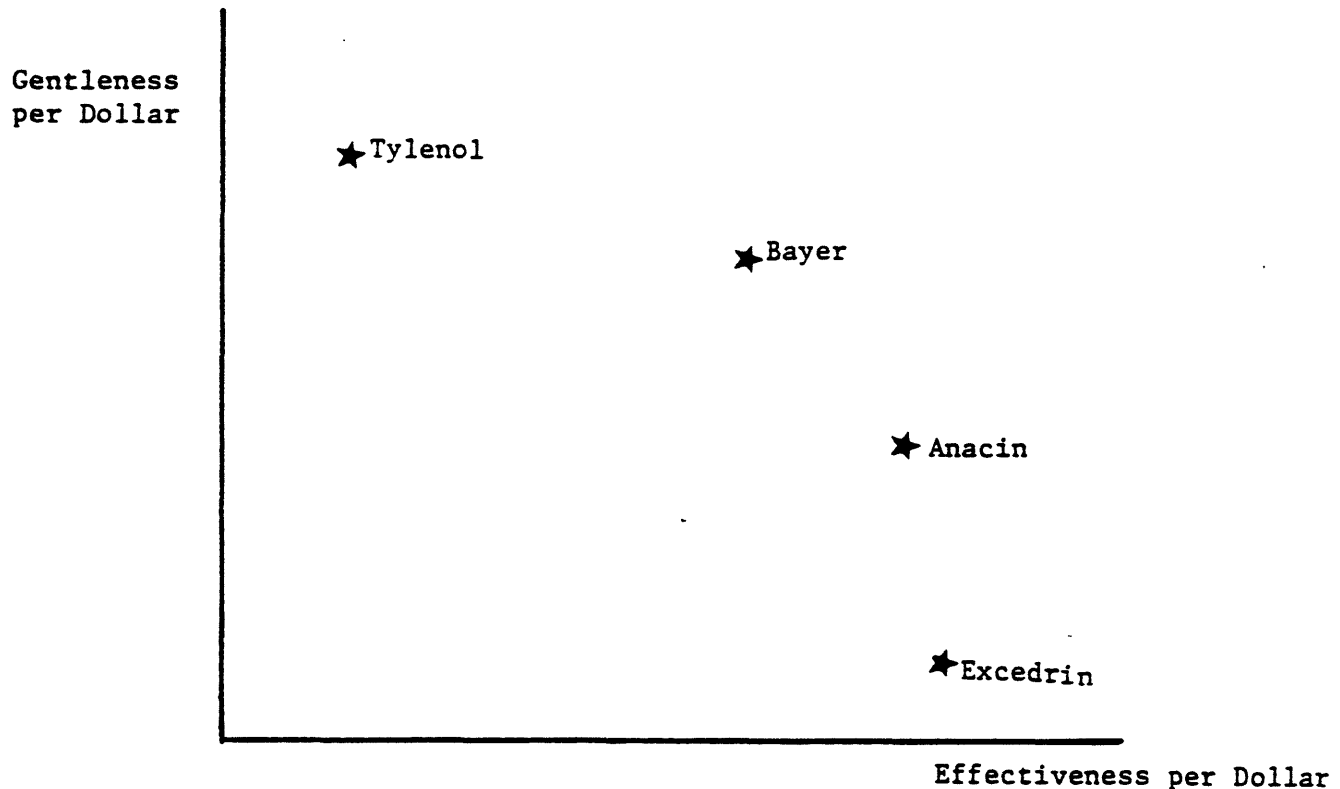

FIGURE 1: Illustrative Perceptual Map

First, the map represents the market from the consumer's perspective, that is, the consumer's subjective reality. The objective reality of the physical ingredients, such as the fact that acetaminophen (Tylenol) does not upset the stomach as much as aspirin, influences subjective reality, but so does advertising, package design, social influence and other variables. The map summarizes the impact of the actual product and some important marketing strategies. The evidence for and the implications of such a map as compared to a traditional applied economics physical characteristic map (a la Lancaster, 1971) are summarized in Hauser and Simmie (1981).

Second, the map represents products "per dollar". Such scaling is familiar to economists, e.g., Lancaster (1971), and can be readily extended to perceptual space by postulating a mapping from physical characteristics (and psycho-social cues) to perceptions. But the Lancasterian framework is sufficient, not necessary. For example, Figure 1 also results if the "goods" utility function is weakly separable (Blackorby, Primont and Russell, 1975), preference for analgesics is linear in 'gentleness' and 'effectiveness', and we focus on market share. Analytically, we use "per dollar" scaling to incorporate price (and budget constraints) explicitly into the map. In reality, "per dollar" scaling is an approximation, but one that seems to be reasonable empirically (Hauser and Gaskin, 1984; Hauser and Urban, 1984).

Finally, the map in Figure 1 assumes consumers are homogeneous in their perceptions of products. Empirically, different consumers perceive products differently, but such heterogeneity of perceptions can be summarized by multivariate normal distributions. In most cases, it is practical to use the centroid of the distribution as the map position and fold heterogeneity into consumer tastes. See Hauser and Simmie (1981) and Section 7 of this paper for models with heterogeneous perceptions.

Consumer Choice. Assume for a moment that consumers are aware of all four products in Figure 1, know the map positions, and find these products to be available. Behavioral science and market research practice suggest that in perceptual space, it is quite reasonable to approximate preference tradeoffs as linear. (In other words, non-linear indifference curves in characteristics space become approximately linear in perceptual space.)

We assume consumers vary in their tastes, i.e., trade-offs among 'effectiveness' and 'gentleness', and, since trade-offs are linear, we represent each consumer's tastes by the angle their indifference curve makes

with the vertical axis. As shown in Figure 2a, consumer 1 (90°) will choose Tylenol, consumer 2 (60°) will choose Bayer, and consumer 3 (0°) will choose Excedrin. As shown in Figure 2b, all consumers with taste angles between α_2 and α_3 will choose Bayer.

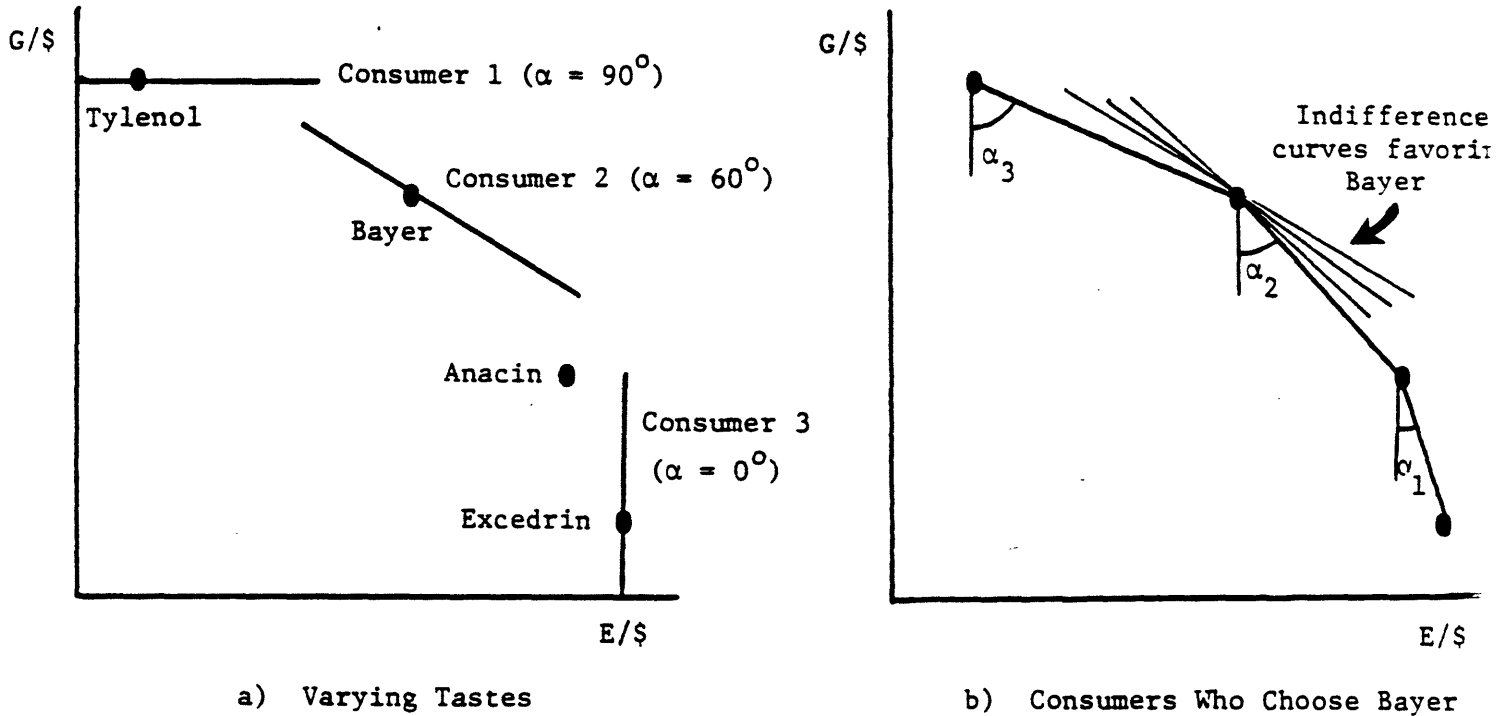

FIGURE 2: Preference Tradeoffs Imply Choice

Finally, as shown in Figure 3, the market share of Bayer is simply the area under the taste distribution, $f(\alpha)$, between α_2 and α_3 . The market share of Tylenol is the area between α_3 and 90° .¹

Three comments are in order. First, we have focused on market share. This assumes that the impact of a price change on category volume is small relative to the impact on share. For large price changes we must extend the model to category volume.

¹For example, for uniformly distributed tastes, the market share of Bayer is simply $(\alpha_3 - \alpha_2)/90^\circ$.

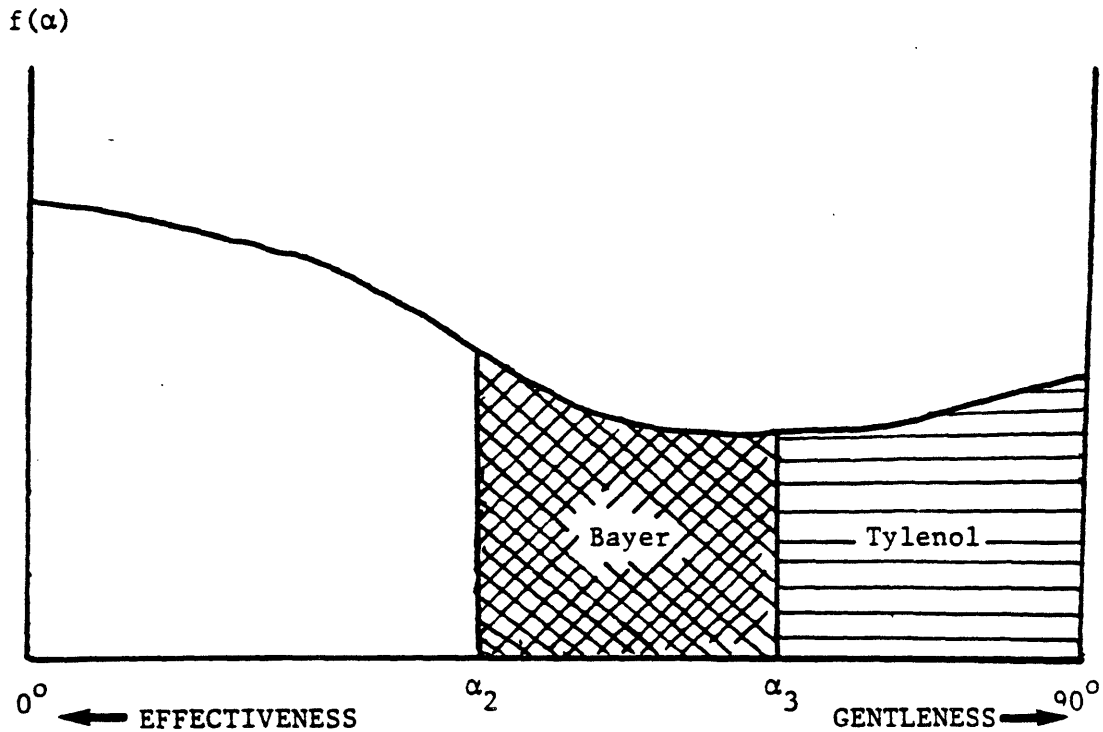

FIGURE 3: Distribution of Consumer Tastes

Second, the analytic mechanism of using polar coordinates, α , for tastes is powerful because (1) the domain of tastes is closed and bounded, (2) the interpretation is symmetric in the two taste dimensions, and (3) the expression for market share, $\int_{\alpha_2}^{\alpha_3} f(\alpha) d\alpha$, is analytically tractable.

Finally, we can easily extend this model to three or more perceptual dimensions by defining the appropriate taste angles, see Hauser and Gaskin (1984).

Information. In a typical product category, a consumer usually has good information on only a small fraction of the available products. (Of the 164 makes of automobiles, how many can you evaluate? Of the more than 25 deodorant brands, how many can you even name?) This phenomena is well-documented, e.g., Silk and Urban (1978) and quite prevalent in

marketing models. We call the set of products a consumer can evaluate his "evoked set." For example, for four analgesic products, there are 15 possible non-null evoked sets including {Tylenol, Bayer, Anacin, Excedrin}, {Tylenol, Bayer}, {Tylenol}, etc.

We also allow consumers to be heterogeneous in their information, i.e., evoked sets. Thus, if S_ℓ is the proportion of consumers using evoked set ℓ , $f_\ell(\alpha)$ is the taste distribution of consumers using evoked set ℓ , and A_ℓ are the angles favoring a product, say Bayer, for evoked set ℓ , then the market share of that product, Bayer, is simply:

$$\sum_{\ell} S_{\ell} \int_{A_{\ell}} f_{\ell}(\alpha) d\alpha \quad (1)$$

Note that advertising, distribution, and other marketing strategies impact information by changing the evoked set probabilities, S_ℓ .

Advertising. Advertising has two main effects, awareness and repositioning. "Share of voice", i.e., total advertising spending, has a major impact on influencing consumers to consider a product. We model this impact as increasing the evoked set probabilities, S_ℓ , for those evoked sets containing the product. The usual assumption is decreasing marginal returns, i.e., that S_ℓ is a non-decreasing and concave function of advertising spending.

The advertising message, its "copy", has a major impact on the product's position in perceptual space. Changing a product's position influences the share of taste angles favoring a product, $\int_{A_{\ell}} f_{\ell}(\alpha) d\alpha$, and, hence, the market share. Again, we normally assume that a product's position, along a dimension, say 'effectiveness', is a non-decreasing and concave function of advertising spending allocated to stressing 'effectiveness'.

By separating advertising into its components we can analyze both the magnitude and the message of advertising. Implicit in this model is a focus

on long-run strategy (we allow S_{ρ} to rise and fall as a function of long-run advertising investment). To analyze short run strategy, we need to add carry-over effects, lagged effects, and other dynamic phenomena. See, for example, Little (1979).

Product Quality. Quality is just a single dimension of consumers' perceptions, e.g., 'effectiveness', or a combination of the dimensions.

Production Cost. Investments in production or improved ingredients affect the physical characteristics of a product and hence its perceived position. Again, we assume a product's position is a non-decreasing and concave function of production costs. When necessary, we separate production cost into components corresponding to each perceptual dimension.

In Hauser and Shugan (1983), we assume constant returns to scale for analytic simplicity. The assumption of constant returns is sufficient but not necessary to obtain our results. This is one area of potential research.

Product Ingredients and Features. These affect a product's position. For example, adding caffeine to aspirin (as in Anacin) increases its perceived 'effectiveness'. Even in automobiles, features such as cruise control and air conditioning or quality control such as "fit and finish" have been modeled empirically as impacting an automobile's perceived position.

Price. Because a product is represented by its position in "per dollar" perceptual space, a change in price moves a product in that space.² Because a product's position affects share through equation (1), this price effect is highly non-linear, but tractable.³ As

²Specifically, a price decrease (increase) moves a product out (in) along a ray connecting a product to the origin.

³Even for uniformly distributed tastes, where $\int f_{\rho}(\alpha) d\alpha = (\alpha_3 - \alpha_2)/90^\circ$, the boundary angles, α_2 and α_3 , are related by an arctan function to ratios of the differences between Tylenol, Bayer, and Anacin's positions.

discussed above, this approximation in price response can be relaxed in future research.

Distribution. One result of investment in the channel of distribution is increased availability, and, hence, evoking, of a product. This component of distribution affects the evoked set probabilities, S_{ℓ} . We can also model other aspects of distribution by their impacts on a product's position or its price.

Promotion. We have not yet analyzed the impact of promotion analytically, but in our empirical applications, we approximate long-term promotion effects as temporary price decreases. We use equation (1) to compute the market share at full price and separately to compute the market share when the product is on promotion. Long-term share is a weighted combination of the two shares.

This completes the brief discussion of the consumer model. Each assumption is well-documented empirically (see Hauser and Simmie 1981, and Hauser and Shugan 1983 for references), but we have obtained marketing richness at some sacrifice. In particular, we assume constant returns to scale, approximate price by its effect on a product's "per dollar" position, and focus on share. Despite these tradeoffs, I hope you find this model interesting and I hope you choose to investigate the implications of relaxing these assumptions.

I now use the model to interpret a historical case of defensive marketing and then turn to the theoretical implications of the consumer model.

3. A SIMPLIFIED HISTORICAL CASE: TYLENOL vs. DATRIL

The histogram in figure 3 represents the market share of Tylenol when every consumer evokes every product in the perceptual map. When evoked set effects are considered, equation (1) causes us to modify the histogram in figure 3. For example, for the evoked set, {Tylenol, Excedrin}, Tylenol will capture all consumers who have tastes between 45° and 90° , rather than all consumers between 60° and 90° . For the evoked set, {Tylenol}, Tylenol will capture all consumers. When we sum together Tylenol's shares of the $f_{\alpha}(\alpha)$'s, we are likely to get a region of $f(\alpha)$ that is large for taste angles favoring gentleness but tapers off more slowly than that shown in Figure 3. Figure 4 is one such representation of Tylenol's consumers.

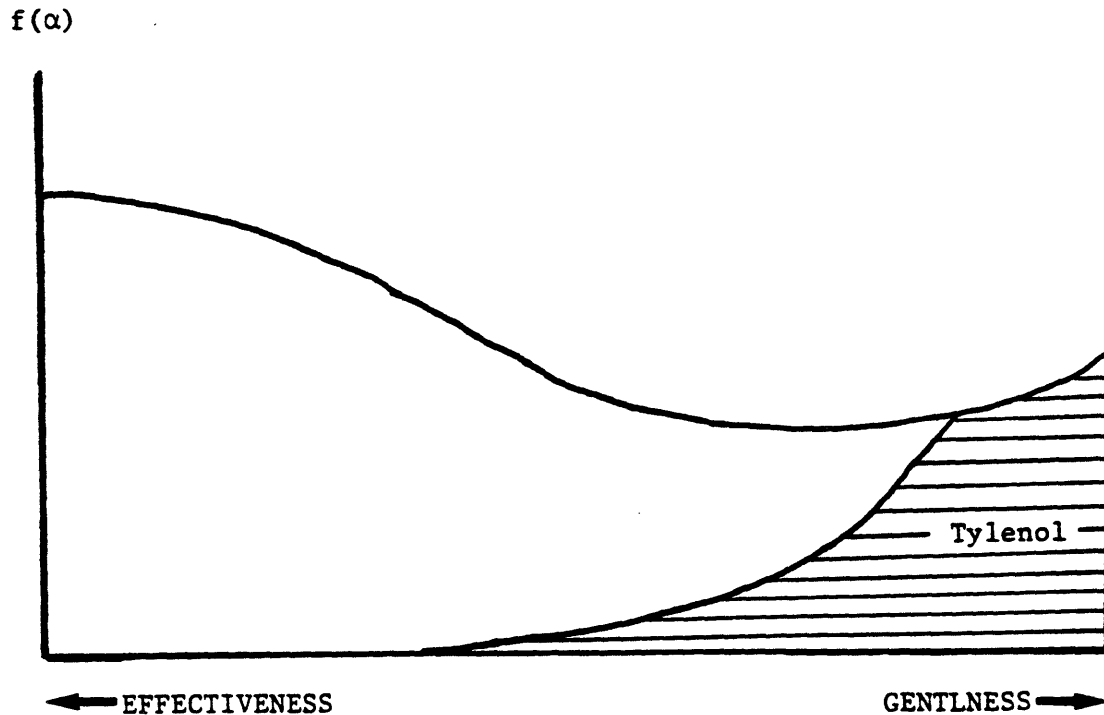

FIGURE 4: Consumers Who Favor Tylenol When We Consider Evoked Set (Information) Effects

In the early 1970's, Tylenol had a reasonable share of the market even though it was not nationally advertised. (Its awareness come from doctor's

recommendations which in turn were strongly influenced by McNeil Laboratories', a division of Johnson & Johnson, "detail" force.)⁴ Recognizing the opportunity for competition along 'gentleness', Bristol-Myers introduced an acetaminophen based product, Datriil, nationally advertised as "just as good as Tylenol, only cheaper". Such a positioning puts them on the map as shown in Figure 5a.

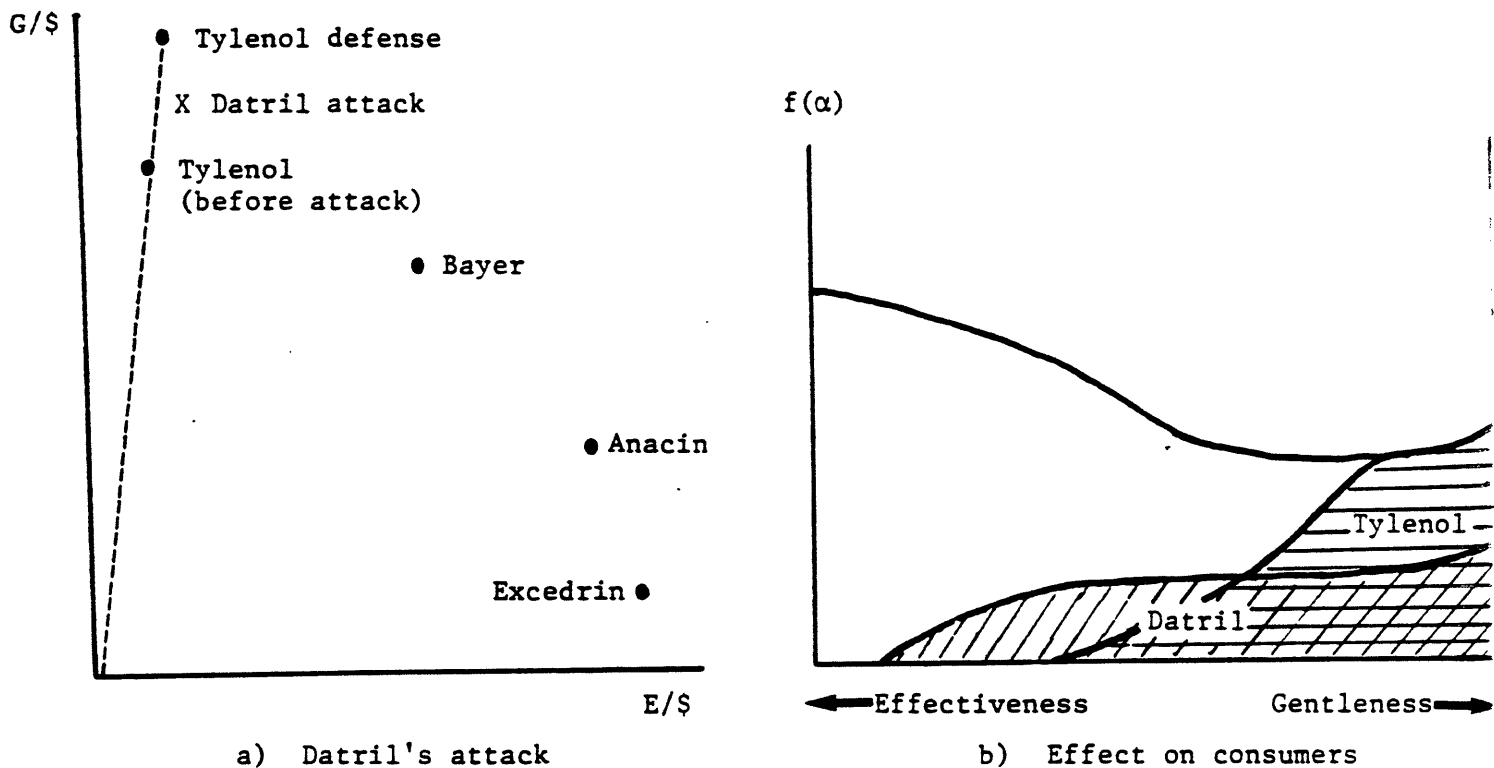

FIGURE 5: Interpretation of Tylenol - Datriil Case

Datriil now has the potential to impact Tylenol's share dramatically. Even national advertising would not reach all of Tylenol's consumers, but it will reach some Bayer, Anacin, and Excedrin consumers. Furthermore, Datriil is now positioned better than Tylenol to compete with Bayer, Anacin, and

⁴A detail force is a salesforce that calls on doctors to make them aware of a drug, stress its benefits, and encourage them to recommend it to consumers.

Excedrin. Had Tylenol done nothing, Datril might have captured the area shown in Figure 5b.

In top level strategy meetings, Johnson & Johnson decided to fight back strongly. Literally over a weekend, they mobilized the Johnson & Johnson salesforce (not just the McNeil division's salesforce), matched Datril's price, persuaded the television networks that Datril's price advantage was now false advertising, and began other defensive measures. The result was that Tylenol, with its strong image from years of detailing, leap-frogged Datril and successfully trumped Bristol-Myer's challenge.

Awakened to the potential of the Tylenol brand, McNeil Laboratories became a national advertiser, added the Extra Strength Tylenol brand to capture consumers interested in 'effectiveness', and undertook a number of effective marketing strategies. Until the current ibuprofen challenge, McNeil's marketing has been so strong that identical physical products, Datril, Panadol, and generic acetaminophen, have not been able to draw substantial share from Tylenol. Tylenol was even able to weather a tragic poisoning incident in 1982.

4. THEORY: THE BEST DEFENSE

Tylenol's price decrease was a successful defense. We wondered if this generalized and, if so, under what conditions. Based on the consumer model of Section 2, Steven Shugan, of the University of Chicago, and I published fourteen theorems to summarize the qualitative implications for the best defense. We assumed the defending firm was behaving rationally before the attack (maximizing long-term profit) and that they would react to achieve the best profit available after the attack. We were concerned with how marketing strategy would change as the result of the attack.

Our equilibrium assumption is simple. We assume the attacker enters with perfect foresight as to the defender's reaction and we focus on the primary defender by holding all other firms' strategies constant. In other words, we analyze a two product equilibrium against the background of a more complex, but static, market.

Clearly, more complex equilibria assumptions are potentially interesting and deserve investigation, but we believe this simple assumption is a useful first-step and intuitive arguments (Section 8 of Hauser and Shugan, 1983) suggest that other firms' reactions reinforce the derived qualitative results. Research is now underway using methodologies pioneered by Axelrod and Hamilton (1980) for generic competitive strategies, but we have yet to use analytically the consumer model of Section 2 to derive explicit results for alternative assumptions about equilibrium. Perhaps, I can entice you to do so.

Price Strategy.

Price affects profit through its impact on a brand's position in perceptual space and its impact on the profit margin. A price decrease causes the former to increase causing, in turn, market share to increase, but this is, of course, countered by a decrease in margin.

We first analyze the case of uniformly distributed tastes [$f(\alpha) = 1/90^\circ$ for $\alpha \in [0^\circ, 90^\circ]$). We show that the effect of price on share is stronger than its affect on margin for defensive scenarios. In particular:⁵

RESULT 1. If consumer tastes are uniformly distributed, then profits after the attack can be increased by lowering price from its before attack level.

⁵Formal proofs of all results are in the appendix to Hauser and Shugan, 1983. All results are for two perceptual dimensions.

The result requires a technical condition which we call "regular markets", but extensive simulation suggests the result generalizes to irregular markets. We also show the result generalizes to certain other distributions, for example, the result generalizes for distributions satisfying $f'(\alpha) \leq 0$ for cases where the attacking product is to the upper left of the defending product and $f'(\alpha) \geq 0$ for cases when the attacking product is on the lower right of the defending product.

Interestingly, the result does not hold for all taste distributions. In particular:

RESULT 2. There exist distributions of consumer tastes for which the best defensive price requires a price increase.

Examples are actually easy to create with multimodal distributions.

Intuitively, we can interpret each mode of a probability distribution for tastes as a "market segment". Then, a brand's position gives it something akin to a local monopoly. If the taste distribution is such that (1) before entry, it pays for the defender to have a low price to compete in more than one market segment; and (2) the attacker out positions the defender in one market segment but not in others, then, after attack, it may pay the defender to raise price and, in effect, exploit the local monopolies not under attack.

Results 1 and 2 are derived explicitly for a full information market, but we also show that:⁶

RESULT 3. The best defensive pricing strategy is independent of the best defensive distribution (availability) strategy and the best defensive awareness advertising strategy, but the best defensive distribution and awareness advertising strategies depend upon the price decision.

⁶The result (Theorem 6) is explicit for distribution, but readily extended to awareness advertising. See Hauser and Shugan, pages 337 and 341.

In other words, to the extent that distribution affects availability and advertising affects awareness, Results 1 and 2 are not affected by these variables. Result 3 suggests that price is a key strategic defensive variable and may need to be set at high levels in the organization.

Finally, we show that:⁷

Result 4. If market size does not increase dramatically, optimal defensive profits must decrease if a new brand enters competitively, regardless of defensive price, distribution and awareness advertising strategy.

Result 4 is obvious intuitively if we simply consider the argument that "if we can increase profits after the attack, when the market is more competitive, why did we not do so before the attack?". But Result 4 is important because it cautions us that there may exist strategies in which it is best to prevent a competitor from getting a foothold in a market because once he is in you lose profits. Effectively, Tylenol's historical defensive strategy kept Datril from establishing a "beachhead" in the market for analgesics.

In summary, if the market is unsegmented (uniform distribution of tastes), it pays to lower price as a defensive measure. But, there are cases such as highly segmented markets where a price increase is best. Furthermore, price is a key strategic variable that affects, but is not affected by, decisions on defensive distribution and awareness advertising. Finally, even the best defensive strategy can not maintain profits at the level attained prior to the attack.

Distribution.

In marketing theory, the channel of distribution (wholesalers, distributors, jobbers, retailers, etc.) perform valuable and complex roles

⁷Result 4 is proved explicitly for availability, but easily extended to awareness. I have added the word "dramatically" even though it does not appear in the original theorem. We prove the theorem for "no market size increase". However, "no increase" is sufficient, not necessary.

including, but not limited to, information, persuasion, service, financing, image maintenance, and delivery, as well as participating in negotiations on price. We focus here on one important aspect of that role, making the product available to the consumer. In particular, we examine the availability that can be obtained by investment in distribution. For availability, it is easy to show:

RESULT 5. If the market size does not increase dramatically as the result of the new competitor, the best defensive distribution strategy is to decrease spending on distribution.

Many people find this result counterintuitive. But the intuition is simple if you think of marginal revenue and marginal cost. Result 5 says that the competitive new product has made the market less profitable (see Result 4), hence, the marginal profit for marginal "retailers" is less. If the marginal cost has not changed for persuading these retailers to make the product available, it no longer makes economic sense to invest in those marginal retailers.

Result 5 applies equally well to a multiplicative distribution index such as the common response analysis assumptions prevalent in marketing theory (e.g., Little, 1979) and, if the brand is sold in several markets, Result 5 holds for each market. Result 5 is also symmetric for competitive withdrawals. For example, if a newspaper withdraws from the market as did the Chicago Daily News in the late-1970's, it makes economic sense to increase investment to capture your former competitor's channel of distribution. Indeed, both the Chicago Tribune and Chicago Sun Times fought competitively for the Daily News' subscribers, newsboys, etc.

Product Improvement

We model product improvement as movements in the perceptual map. For example, consider an "upper adjacent" attack as illustrated in Figure 6. We

call the attack "upper adjacent" because the new product is above the defending brand and between the defending brand and its closet competitor. We assume the defender can improve its image by improving its physical product. Of course, such movements increase production cost and may or may not be profitable.

We model movements, such as illustrated by the dotted line in Figure 6, by breaking those movements into their orthogonal components. For upper adjacent attacks, we call improvements along dimension 1, improvements "away from the attack". (Solid line in Figure 6.) Improvements along dimension 2 are "toward the attack". (Dashed line in Figure 6.) In reality, it is rare that a brand can move independently along just one dimension, but we gain valuable insight into the net movement (dotted line) by analyzing each component separately.

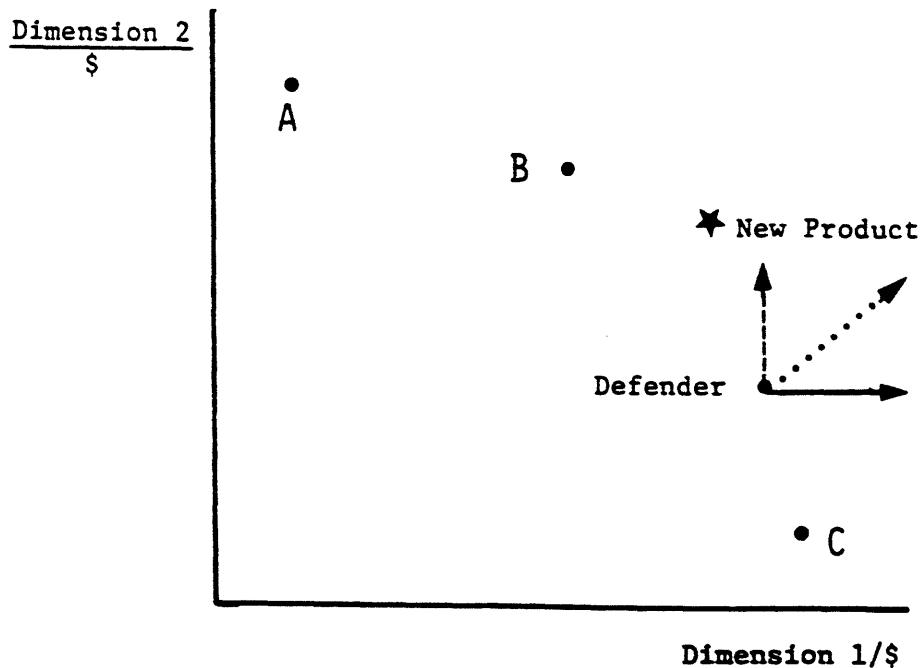

FIGURE 6: Defender's Options Under an Upper Adjacent Attack

It may be possible to obtain global results, but to date we have been only able to obtain clear results "at the margin", that is, for product improvements holding price and other variables constant. In particular:

RESULT 6. If consumer tastes are uniformly distributed and the competitive brand attacks along attribute 2, (i.e., an upper adjacent attack), then, at the margin,

- (a) profits are increasing for product improvements "away from the attack" (along the defender's strength, dimension 1); and,
- (b) under certain conditions, profits are increasing for product improvements "toward the attack" (along the attacker's strength, dimension 2).

The technical conditions for part (b) are given in Hauser and Shugan (1983, Theorem 9). They are interpretable, but not easily. Of course, symmetric results hold for attacks along dimension 1, i.e., lower adjacent attacks, and Result 6 can be extended to other distributions of consumer tastes. We interpret negative movements along either dimension as substituting less costly, lower quality ingredients.

Result 6 turns out to be very useful in practice. In our experience to date, the defending product had obtained its share by being the dominant brand on a key dimension, say brands A or C in Figure 6. Most likely, due to first entrant advantages, it appears the attacking products do not choose a parity position, but rather an upper or lower adjacent attack. Result 6 gives the unambiguous result (for uniformly distributed tastes) that movements to the defending brands strengths pay off. Countermoves must be analyzed more carefully.

Advertising.

A moments reflection reveals that awareness advertising is analogous to availability while repositioning advertising is analogous to product improvements. Here we assume that, before the attack, some level of positioning advertising is required to maintain a product's image for optimal profit. Movements along each component dimension represent

different advertising themes, e.g., 'effectiveness' or 'gentleness'. Movements such as the dotted line in Figure 6 are mixed themes of varying emphasis. Decreases in a component dimension are interpreted as less spending, not as themes designed to lower perceptions.

Because of the analogies to distribution and product improvement, it is not surprising that we were able to prove:

Result 7. If the market size does not increase dramatically as the result of the new competitor, the best advertising strategy includes decreasing the budget for awareness advertising.

Result 8. If consumer tastes are uniformly distributed and the competitive brand attacks along attribute 2 (i.e., an upper adjacent attack), then, at the margin,

- (a) profits are increasing in repositioning spending along the defender's strengths, attribute 1; and,
- (b) under certain conditions, profits are increasing in repositioning spending along the attacker's strengths, attribute 2.

Result 8 is a directional result at the margin, but, for unsegmented markets, Results 7 and 8 combine to give usable qualitative insight on defensive advertising. Together, these results suggest that repositioning advertising is a more effective defensive strategy than advertising that simply informs the consumer about the brand. For example, Tylenol's defensive advertising should favor advertising copy that stresses gentleness rather than copy that stresses Tylenol's name.

Summary.

The eight qualitative results summarized above are a first step toward understanding which defensive actions are most effective. Together, they suggest the directions of change in a defender's marketing variables.

In particular:

- distribution and awareness advertising should be decreased;
- price strategies are independent of distribution and awareness advertising strategies but not vice versa; and,
- profits always decrease as the result of a new competitive brand.

If consumer tastes are uniformly distributed, at the margin, defensive profits are

- increasing for price decreases,
- increasing for product improvements along the defending brand's relative strengths, and,
- increasing for increases in repositioning advertising along the defending brand's relative strengths.

Also, there are cases, e.g., some highly segmented markets, where price increases may be optimal.

5. MEASUREMENT AND ESTIMATION

General qualitative insights are valuable, but marketing managers also want more specific advice. To provide such prescriptions for defensive action we have had to develop practical measurement and estimation techniques for the key components of the consumer model:

- the "per dollar" perceptual map,
- the consumer taste distribution, and,
- the appropriate response functions.

"Per Dollar" Perceptual Maps.

Measurement of consumer perceptions is a well-developed art in marketing and is summarized in many textbooks including my own (with Glen Urban of M.I.T.) on new product development. See Urban and Hauser (1980).

Because much of my applied research incorporates perceptual maps, I once undertook an empirical comparison of the predictive ability of alternative perceptual mapping techniques (Hauser and Koppelman, 1979). Empirically, the best technique seems to be direct measurement in which:

- twenty or so semantic scales are elicited from consumers via qualitative research;
- consumers are asked to rate each product in their evoked set on these scales;

- after standardization of all ratings by individuals, the ratings are factor analyzed where correlations are computed across subjects and stimuli; and,
- map positions are approximated by average factor scores for the brands on each factor dimension.

Factor analytic techniques appear superior empirically to similarity scaling and discriminant analysis of attribute ratings. The raw semantic scales themselves are too highly correlated to be useful. Typically, there are two to four factor dimensions.

Theoretically, factor scores are at best interval scales, but "per dollar" maps require ratio scaled data. Hence, "per dollar" maps are quite controversial in marketing with many researchers believing that "per dollar" maps are infeasible to measure and may not even exist. In practice, we have found that consumers appear to anchor their perceptions on the worst brand along each dimension, hence, if we compute scores relative to the worst brand, the resulting map positions act as if they were ratio scales. Initial evidence is published in Hauser and Gaskin (1984) but more work needs to be done.

Consumer Taste Distribution.

Standard economic techniques for consumer tastes, such as logit analysis, probit analysis, and ordinary least squares, implicitly assume unimodal taste distributions: double-exponential, normal, and normal, respectively. For many situations in marketing science these techniques are quite powerful; however, for defensive strategies, our qualitative results suggest that we need greater flexibility in estimating the consumer taste distribution. Restriction to a unimodal taste distribution could miss, for example, the complexities of price strategies (Results 1 and 2).

We turn instead to the revealed preference technique illustrated in Figure 7. In figure 7, we focus on a single evoked set, {A, B, C}, in which the market shares in the evoked set are 30%, 20% and 50%, respectively. For that evoked set, the relative perceptual dimensions are such that all consumers with taste angles between 0° and 30° choose brand C, those between 30° and 60° choose brand B, and those between 60° and 90° choose brand A. Because 50% of the consumers choose brand C, we know 50% have taste angles between 0° and 30° . Similarly, 20% have taste angles between 30° and 60° and 30% between 60° and 90° .

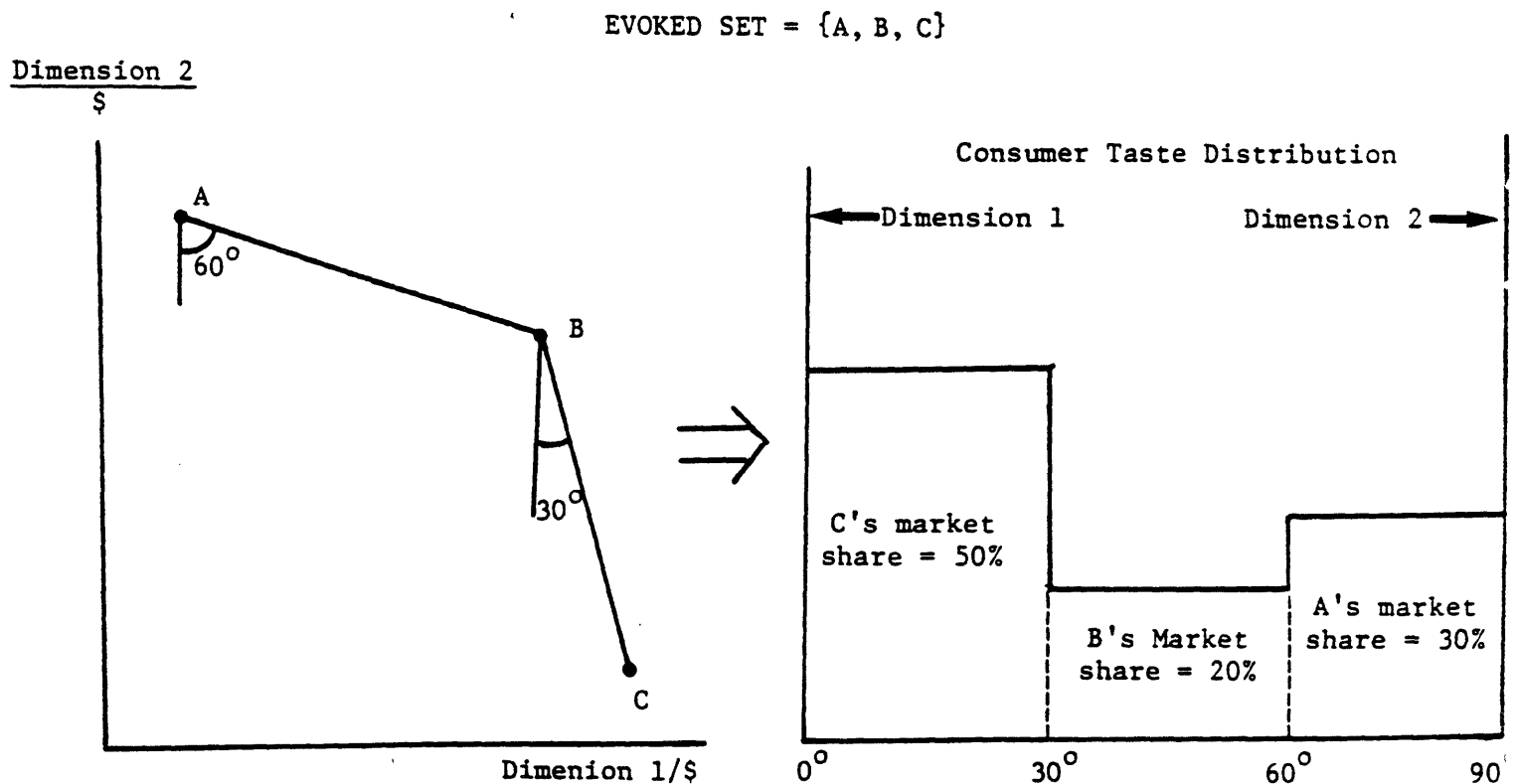

FIGURE 7: Revealed Shape of Taste Distribution for a Single Evoked Set (Using Piece-Wise Uniform Approximation)

There are infinitely many probability density functions (pdf) consistent with these market shares; for a single evoked set, we cannot distinguish among them. In the interest of parsimony, we choose the piecewise uniform pdf illustrated in Figure 7. Fortunately, for most markets, there are many evoked sets possible; 15 for a four product market, 31 for a five product market, etc. To describe the market level pdf we use a weighted sum of evoked set level pdf's.⁸

Clearly, as the number of products in the market increases, the estimated pdf converges to the true pdf. Empirically, we have found this technique to produce reasonable pdf's which appear to predict the new brand shares quite well. See predictive tests in Hauser and Gaskin (1984).

Response Functions.

The full model requires three types of response functions:

- awareness and availability as a function of dollar spending;
- product position as a function of features and or ingredients; and,
- product position as a function of advertising spending on alternative messages.

The first two types are well-developed, the third type requires research.

Awareness and availability response functions are estimated by a variety of standard techniques including experiments, econometrics, and judgment. See review in Little (1979).

Response functions producing preference as a function of product features require a standard marketing research technique, known as conjoint analysis, in which consumers rank or rate factorial designs of product profiles. See review in Green and Srinivasan (1978). It is quite easy to adapt conjoint analysis to product positions. When costs of feature profiles are established, we have the needed mapping from production cost to

⁸For singleton evoked sets, we use triangle distributions sloping toward the single product's strength.

product position. See examples for telecommunications products in Hauser and Simmie (1981) and for educational services in Urban and Hauser (1980, chapter 10).

6. AN EMPIRICAL EXAMPLE

The "DEFENDER" model has been applied seven times to date. I report here our first application. Details are contained in Hauser and Gaskin (1984).

Our first application was to a product category with well over \$100 million in annual sales. There were three major brands in the category plus generic store brands. The defending brand had a dominant position on one of three perceptual dimensions and held a 41% share of the market. Based on the product benefit claims of the new competitive product, the attacker, it appeared that the attacker was attempting to appeal directly to the defender's customers.

For confidentiality, we disguise the three perceptual dimensions as 'professional quality', 'effective control', and 'ease of use'. Since the defender had its strength on 'professional quality' we call it "Pro-Strip". We call the attacker, "Attack", the other brands, "Cata-Kill" and "Tree-Guard", and the generic and private label products, "Store Brand". All other details are as they occurred.

Descriptive Analysis.

The map positions are shown in Figure 8. Notice that "Attack" is definitely attempting to appeal to "Pro-Strip's" customers by positioning strongly on 'professional quality', but better than "Pro-Strip" on 'effective control' and 'ease of use'. However, "Attack" did not match "Pro-Strip's" 'professional quality' appeal. Both "Pro-Strip" and "Attack" are premium products with prices 2.8 times "Store Brand", compared to "Cata-Kill" and "Tree-Guard", with prices 1.3 and 1.2 times "Store Brand", respectively.

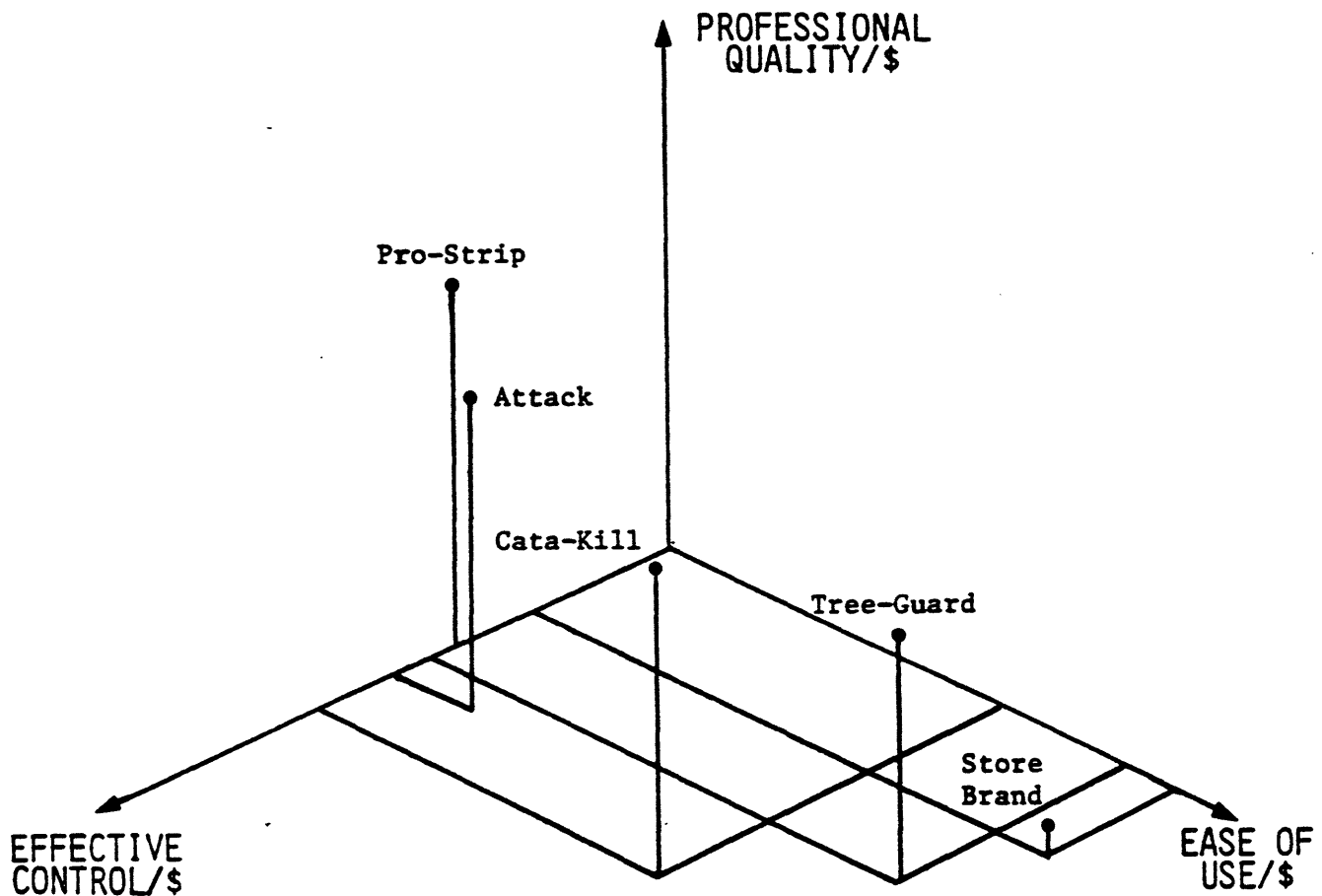
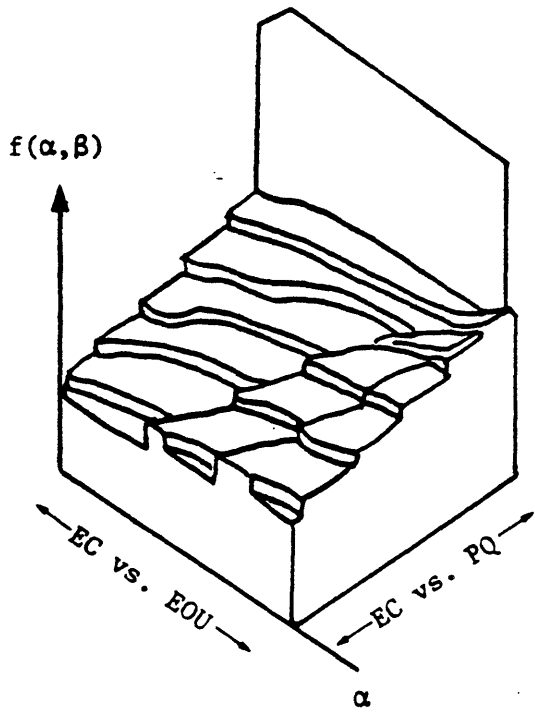
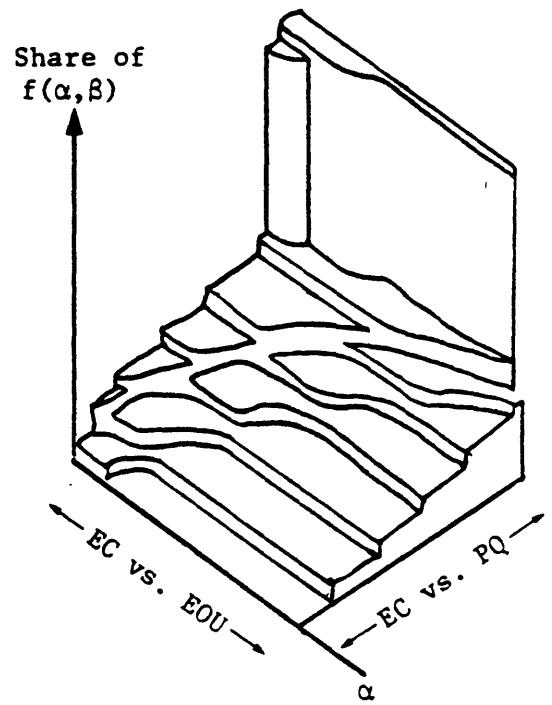

FIGURE 8: Perceptual Map for Empirical Example (Disguised Brand Names)
 [From Hauser and Gaskin, 1984.]

The consumer taste distribution is shown in Figure 9a. Since we have three perceptual dimensions, we need two taste angles representing, respectively, trade-offs among 'effective control' and 'ease of use' and among 'effective control' and 'professional quality'. Figure 9a suggests that trade-offs among 'effective control' and 'ease of use' are approximately uniformly distributed while trade-offs among 'effective control' and 'professional quality' slope upward toward 'professional quality' with a tower at extreme emphasis on 'professional quality'. This tower represents a market segment of consumers who demand 'professional quality' and are willing to sacrifice 'effective control' and 'ease of use' to get it.



a) Consumer taste distribution



b) Pro-Strip's share before Attack

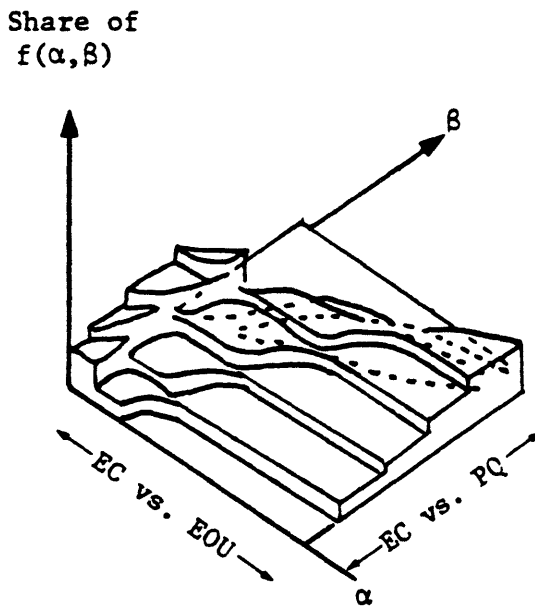

c) Attack's share

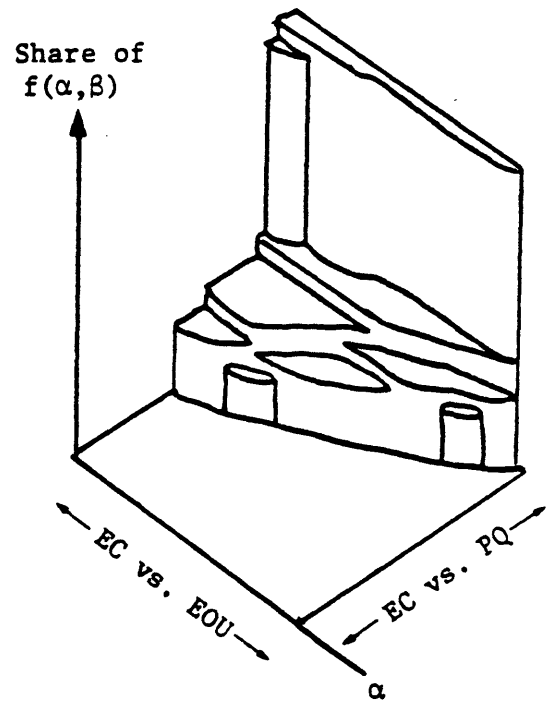

d) Pro-Strip's share after Attack

FIGURE 9: Consumer Taste Distribution and Shares for "Pro-Strip" and "Attack" (Disguised Brand Names) [from Hauser and Gaskin, 1984.]

Figure 9b shows those consumers who chose "Pro-Strip". As expected, "Pro-Strip" captures the 'professional quality' segment and gets most of its business from that segment. Because they are the major advertiser in the category, "Pro-Strip" does well in many evoked sets and, hence, also captures some less extreme customers. The customers of the other products are not shown explicitly, but "Cata-Kill" and "Tree-Guard" capture more central portions of the taste distribution and "Store Brand" captures the 'ease of use' portion. (See details in Hauser and Gaskin, 1984.)

When "Attack" enters the market, shares change. Assuming 100% awareness and distribution (full evoking), we place "Attack" on the perceptual map and compute its share of the taste distribution. In part, because "Attack" cannot match "Pro-Strip" on 'professional quality' it does not capture the 'professional quality' segment but instead the area shown in Figure 9c. Figure 9d projects the effect on "Pro-Strip" of "Attack" if it were to obtain full evoking. "Attack" would hurt "Pro-Strip" by drawing from "Pro-Strip" its more moderate customers. (At less than 100% evoking, we scale down figure 9d by "Attack's" evoking percentage and forecast "Pro-Strip's" share as a weighted combination of Figures 9b and 9d).

Based on Figure 9, "Pro-Strip's" defense is clear. To regain its share and/or preempt "Attack" it must regain consumers with moderate taste trade-offs. However, strategically, "Pro-Strip" must maintain a 'professional quality' image to preempt future attacks through repositionings by "Attack".

Prescriptive Analysis.

We analyzed many defensive scenarios for "Pro-Strip"; I illustrate here only the price analysis.

To compute the price response, we first compute the effect of a change in price on "Pro-Strip's" position, and use the new map and the estimated taste distributions to compute "Pro-Strip's" new share. Using accounting data on fixed and variable costs and response functions for advertising, we (1) compute the optimal advertising budget and (2) the resulting annual profit. Notice that "Attack's" position is held constant for this exercise. In practice, we also analyze competitive response scenarios. Because competitive costs are well-guarded secrets, full equilibrium analysis cannot be run.

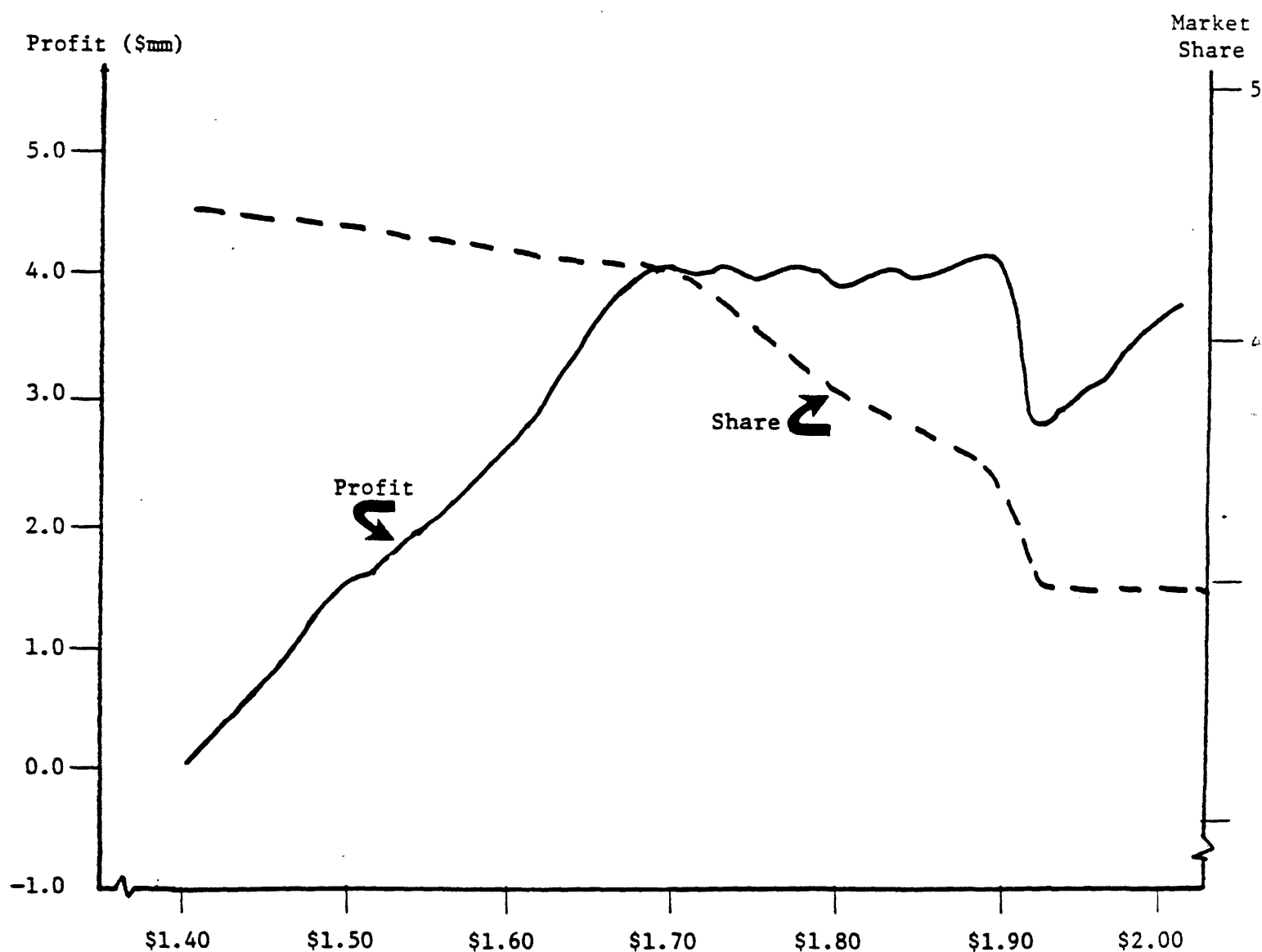

FIGURE 10: Profit and Market Share for "Pro-Strip" Prior to Entry of "Attack" (Price is per unit in 1982 dollars. Profit is in 1982 dollars but multiplied by a constant for confidentiality.)

Figure 10 shows "Pro-Strip's" profit and market share as a function of price (in 1982 dollars) prior to "Attack's" entry. Remember, each point in Figure 10 is the result of an optimization on other marketing variables.

Profit rises rapidly as price increases until about \$1.67, at which point it levels off until about \$1.88. In this range, increases in margin roughly cancel decreases in market share. The rise again after \$1.88 is the result of exploiting the 'professional quality' segment and is viewed as an unacceptable option for "Pro-Strip". Since long-run strategy represents a trade-off among annual profit and market share and since Figure 10 is an estimate,⁹ not exact values, "Pro-Strip" was using \$1.69 as its average price.

Based on "Attack's" entry, we recompute profit and share as shown in Figure 11. "Pro-Strip's" share is now more sensitive to price. If the model's predictions are perfectly accurate, the best defensive price is just under \$1.69. When measurement error is taken into account, the most we can say is that the best defensive price is in the range of \$1.69.

Like many brand managers, the "Pro-Strip" managers felt pressure to react immediately and did so prior to the DEFENDER analysis. Their gut reaction was to raise margins by 5¢ to compensate for the loss of share to "Attack". Their rationale was to "protect the profitability of the brand". Unfortunately, based on the model, this was not the best move. Had they held price, they could have retained approximately \$500,000 more in annual profits and 3.4% more in market share. Had they dropped price to \$1.59, they could have retained the same profit as was retained at \$1.74, but at a

⁹A price of \$1.82 yields a slightly higher profit, but a much lower share. Furthermore, the profit differences between price strategies of \$1.69 and \$1.82 are not significant statistically.

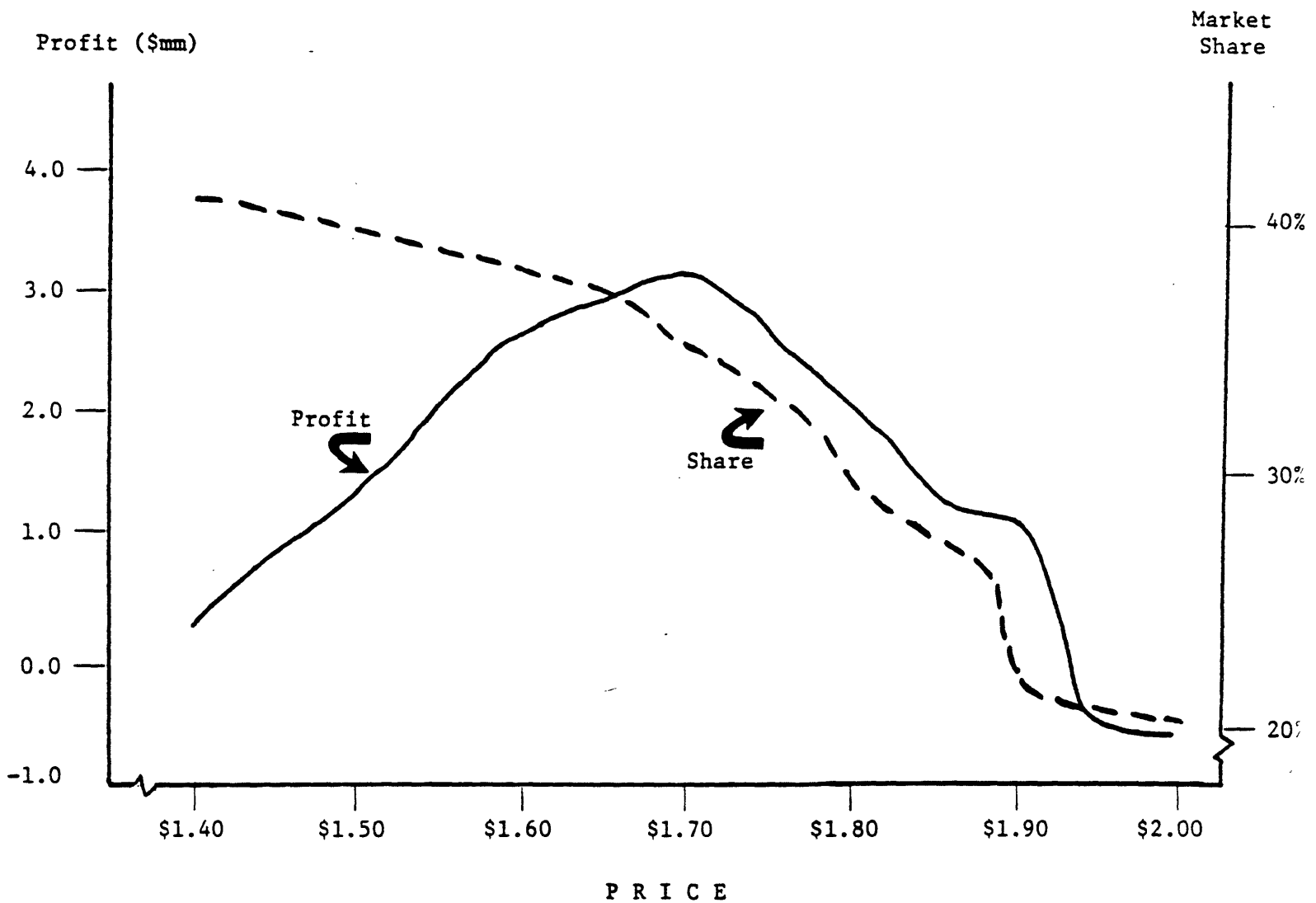

FIGURE 11: Profit and Market Share for "Pro-Strip" After the Entry of "Attack"

market share level 6.3 points higher. After our analysis, they moved price back toward \$1.69.

Other Applications.

In a second application (to another \$100 million category) with the same firm, we were able to determine that the defending firm should not launch a

defensive product line extension, but rather match the attacker's price cuts and move to maintain dominance on dimension 1.

In an application to a U.S. firm in OTC drugs, we analyzed potential attacks. Our analysis helped the firm prepare for future attacks and, serendipitously, identified a new product opportunity.

In another U.S. OTC application, we determined that the attack was not now a threat, but could be in the future if the attacker lowered price by 30% and invested heavily in advertising. Since the competitor was committed to the market, this was a very real threat. A number of alternative scenarios were simulated, a monitoring system put in place, and defensive plans developed.

In an application to decision support software, we were able to suggest that a "mainframe" software firm move rapidly to develop micro compatibility.

In a Japanese application to a food category, the firm was not under attack but expected multiple attacks in the near future. We simulated profit and share for a variety of attacks to understand the defender's vulnerability and suggest preemptive moves.

In another Japanese application, this time to a non-food category, the firm was under attack and expected new attacks. Its goal was to maintain labor force employment and wanted to know what must be done to counter these attacks. Interestingly, in this application the Osaka and Tokyo markets were so different that we had to explicitly model both.

We are now undertaking and seeking new applications worldwide. With enough experience we will develop valuable generalizations about the behavior of firms in both defensive and attacking modes.

7. WHERE DO WE GO FROM HERE?

This completes my brief summary of our research to date on defensive marketing strategy. We feel we have made progress but we are humbled by the questions left unanswered.

Current Projects.

Heterogeneous Perceptions. The model in Section 2 assumes heterogeneous tastes but homogeneous perceptions. This is but an approximation since perceptions, preferences and even choice rules are known to be heterogeneous. In our applications, we have extended the model to incorporate heterogeneous perceptions. Following ideas in Hauser and Simmie (1981), we assume perceptions are distributed normally about their centroids such that for any taste angle the probability of choosing a product is given by a probit model. We then use a matrix extension¹⁰ to the procedure illustrated in Figure 7.

The matrix extension works well and has the theoretical advantage that a brand can be inefficient on average in an evoked set, yet have non-zero market share in the evoked set due to heterogeneity of perceptions. See discussion in Hauser and Simmie (1981, pp. 42-44).

The Poker Game. Anyone with managerial experience quickly realizes that competitive strategy is a real poker game with bluffs, gambles, and

¹⁰Divide the feasible tastes into J regions, each favoring a single product. Let f_p be the height of the uniform distribution in region p. Let C_p be the angles in region p, let $\delta_j(\alpha)$ be the probability product j is chosen for taste angle α and let $d_{jp} = \int_{\alpha \in C_p} \delta_j(\alpha) d\alpha$. Let M_j be the observed market share of product j. Then, the appropriate fitting equation is $\int_p d_{jp} f_p = M_j$ for all j, or in matrix form $DF = M$. When D is full rank, we have $F = D^{-1}M$. There are empirical cases where C_p is null causing D to be singular and there are empirical cases where one or more f_p 's are negative. We have developed modifications for these cases using brand specific constants. The method works just as well when α is a vector.

other complications. Our theorems and models provide guidance but do not model this phenomena endogenously. Furthermore, simple equilibrium assumptions such as the Cournot assumption just do not seem to capture the flavor of managerial practice.

My colleagues and I are addressing this issue with a multifront research agenda. (1) We are continuing applications to get a breadth of managerial experience. (2) We are undertaking qualitative interviews with each major player in key industries to determine what managers believe are their decision strategies. (3) We are developing simplified competitive models and sponsoring contests similar to the Axelrod and Hamilton (1981) iterated prisoner's dilemma contest. And (4), we are hoping to develop analytical models based on the consumer model in Section 2 under a variety of equilibrium assumptions.

Revealed Image. Following standard marketing science paradigms, we have chosen to measure perceptions directly and estimate the taste distribution based on the measured perceptions and observed market shares within evoked sets. The consumer model in Section 2 is quite flexible; we can also estimate perceptions if (1) we assume a taste distribution, and (2) observe market shares under a variety of price scenarios. See simple example in Hauser and Shugan (1984, pp. 345-349). My colleague at the University of Chicago, Steven Shugan, has applied these ideas to estimate perceptual maps from weekly data on market share and price which was obtained from automated supermarket checkouts. Although he assumes a uniform distribution and is limited to two perceptual dimensions, his method looks promising and produces perceptual maps with good "face validity".

Future Directions.

Here are a few of the questions we hope to answer as we probe further defensive marketing strategy:

- full n-product equilibrium, extending or challenging the results to date,
- further understanding of the taste distributions which lead to price decreases,
- qualitative analyses of temporary price reductions (deals),
- qualitative analyses of the dynamics of consumer response and profit optimization,
- qualitative analyses of non-constant costs and/or costs leading to entry barriers,
- qualitative analysis of how to enter a market with full foresight on the defensive response of existing products,
- empirical studies of how firms do respond and whether they are successful,
- inter-category or inter-divisional interactions, and
- many more.

You will note that many of these questions require applied economics methodology. I hope you find them exciting.

REFERENCES

1. Axelrod, R. and W. D. Hamilton, "The Evolution of Cooperation," Science, Vol. 11, No. 27 (March 1981) pp. 1390-1396.
2. Blackorby, C., D. Primont and R. R. Russell, "Budgeting, Decentralization, and Aggregation," Ann. Econom. Social Measurement, Vol. 4, No. 1 (1975) pp. 23-34.
3. Hauser, J. R. and S. P. Gaskin, "Application of the 'DEFENDER' Consumer Model," forthcoming, Marketing Science, Vol. 3, No. 4 (Fall 1984).
4. Hauser, J. R. and F. S. Koppelman, "Alternative Perceptual Mapping Techniques: Relative Accuracy and Usefulness," Journal of Marketing Research, Vol 16, No. 4 (November 1979) pp. 495-506.
5. Hauser, J. R. and S. M. Shugan, "Defensive Marketing Strategy," Marketing Science, Vol. 2, No. 4 (Fall 1983), pp. 319-360.
6. Hauser, J. R. and P. Simmie, "Profit Maximizing Perceptual Positions: An Integrated Theory for the Selection of Product Features and Price," Management Science, Vol. 27, No. 2 (January 1981), pp. 33-56.
7. Hauser, J. R. and G. L. Urban, "Consumer Durables: Actual Budgets Compared to the Value Priority Models," Proceedings of the ESOMAR-Congress, Rome, Italy, September 1984.
8. Lancaster, K., Consumer Demand: A New Approach (Columbia University Press: New York, NY), 1971.
9. Little, J. D. C. L., "Aggregate Advertising Models: The State-of-the-Art," Operations Research, Vol. 27, No. 4 (July - August 1979), pp. 629-667.
10. Little, J. D. C., "Decision Support Systems for Marketing Managers," Journal of Marketing, Vol. 34, No. 3, (Summer 1979), pp. 9-27.
11. Silk, A. J. and G. L. Urban, "Pre-Test Market Evaluation of New Packaged Goods: A Model and Measurement Methodology," Journal of Marketing Research, Vol. 15, No. 2 (May 1978), pp. 171-191.
12. Urban, G. L. and J. R. Hauser, Design and Marketing of New Products (Prentice-Hall, Inc.: Englewood Cliffs, NJ), 1980.