

STRATEGY OF ECONOMIC DEVELOPMENT IN IRAN:  
A CASE OF DEVELOPMENT BASED ON  
EXHAUSTIBLE RESOURCES

by

Ali Naghi Mashayekhi

B.S., Arya-Mehr University of Technology  
(1970)

SUBMITTED IN PARTIAL FULFILLMENT

OF THE REQUIREMENTS FOR THE

DEGREE OF

DOCTOR OF PHILOSOPHY

at the

MASSACHUSETTS INSTITUTE OF TECHNOLOGY

March 1978

Signature of Author.....  
Alfred P. Sloan School of Management, March 1978

Certified by.....  
Thesis Supervisor

Accepted by.....  
Chairman, Departmental Committee on Graduate Students





STRATEGY OF ECONOMIC DEVELOPMENT IN IRAN:  
A CASE OF DEVELOPMENT BASED ON  
EXHAUSTIBLE RESOURCES

by

Ali Naghi Mashayekhi

Submitted to Alfred P. Sloan School of Management,  
March 1978,  
in partial fulfillment of the requirements  
for the Degree of Doctor of Philosophy

ABSTRACT

Oil revenues give Iran a transitory opportunity for economic growth and development. The revenues provide financial resources to stimulate the economy, increase investment, and import the necessary goods and services to accelerate economic growth. Economic growth based on oil exports increases the dependency of the economy on imports financed by oil revenues. However, oil is an exhaustible resource. Iranian economy will go through a transition into an oil-independent era as oil runs out. In this thesis, a system dynamics model is constructed to analyze the transition. Model simulation is used to examine alternative policies to achieve a smooth transition. The thesis shows that if Iran continues to increase oil exports in response to domestic foreign exchange requirements, the country would face an economic crisis as oil runs out. In order to achieve a smooth transition, Iran should (1) restrict growth of oil exports to expand the life of oil reserves, (2) restrict food

imports to encourage agricultural expansion and to become less dependent on imported food financed by oil revenues, (3) limit expenditures on imported arms financed by oil revenues to decrease pressures on foreign exchange requirements, and (4) encourage imports substitution in intermediate and capital goods industries while non-oil exports are expanded as fast as possible.

Thesis Supervisor:

Jay W. Forrester

Title:

Germeshausen Professor



## ACKNOWLEDGEMENTS

In this work, I am indebted to many persons, both personally and intellectually, for their time, interest, and concern. It is with pleasure that I recognize these debts.

Professor Jay W. Forrester was chairman of my doctoral dissertation committee. To Professor Forrester my debt of gratitude goes far beyond an appreciation for his general supervision, guidance, support, and encouragement in the underlying research and writing of this thesis. His lectures and writings have enriched my knowledge of System Dynamics as a new way to understand our dynamic world.

Professor Nathaniel J. Mass, who was a member of my thesis committee, provided valuable advice and guidance. During the last three years, I have benefited substantially from his knowledge of System Dynamics and his insistence on clear thinking and writing. His comments and feedback were very helpful from the beginning, when I started to identify a problem for my thesis, to the end of the research process. The other two members of my committee, Senior Research Associate K. Nagaraja Rao and Professor Richard Robinson, provided valuable advice regarding the substance and presentation of the thesis. I am very thankful to them for their time, interest, guidance, and encouragement.

I should like to thank Professors Alan K. Graham, Gilbert W. Low, James M. Lyneis, and William A. Shaffer, who, through different discussions and comments, contributed to this work and my understanding of System Dynamics. I am also thankful to Mr. Charles Ryan for his helpful suggestion with regard to the presentation of this work.

"The Friday Morning Group," a voluntary seminar of Ph.D. students, contributed actively to this work and became one of my best educational experiences at M.I.T. David Anderson, Mike Garet, Mats Lindquist, and I had wonderful Friday mornings with constructive criticisms and discussions about each other's works during the two year period. We recommended to the new students that they have such a meeting and hoped that the meeting would continue and keep its constructive spirit.

I benefited from the comments and conversation of other fellow students, too. Barry Richmond's suggestions with regard to substance, organization, and writing were extremely helpful. Barry, quite friendly, served as a first filter for most of my writings. I am very thankful to Barry for his great help. I also had helpful discussions with Homayoon Dabiri and Khalid Saeed about this work and would like to thank them, too.

I am grateful to Arya-Mehr University of Technology and Ministry of Science and Higher Education in Iran for their financial support. My thanks are also due to the System Dynamics Group, which provided typing expenses, and to Mr. Rob Kaplan and Ms. Marilyn Nelson, who typed the manuscripts.

Finally, without the understanding and support of my wife, Parivash, this these could not have been finished. Despite her busy schedule, she patiently and kindly undertook a part of my responsibility with regard to family life and our children, Farzad and Farshad. Thank you Parivash, Farzad, and Farshad for all your support and understanding.

TABLE OF CONTENTS

ABSTRACT.....	3
CHAPTER 1: STATEMENT OF THE PROBLEM.....	11
1.1    INTRODUCTION.....	12
1.2    THE PERFORMANCE OF THE IRANIAN ECONOMY FROM 1959 THROUGH 1976.....	15
1.3    A POSSIBLE CRISIS.....	32
1.4    PREVIEW OF THE FOLLOWING CHAPTERS.....	37
CHAPTER 2: GENERAL OVERVIEW OF THE MODEL.....	41
2.1    ALLOCATION OF PRODUCTION FACTORS.....	43
2.2    AGRICULTURAL SECTOR.....	44
2.3    DETERMINATION AND ALLOCATION OF PRODUCTION CAPACITY IN THE NON-AGRICULTURAL SECTORS.....	45
2.4    CAPITAL GOODS SECTOR.....	46
2.5    INTERMEDIATE GOODS SECTOR.....	46
2.6    EDUCATION SECTOR.....	47
2.7    CONSUMPTION GOODS SECTOR.....	48
2.8    TECHNOLOGY SECTOR.....	49
2.9    ALLOCATION OF INCOME.....	50
2.10   TRADE SECTOR.....	51
2.11   OIL SECTOR.....	51
2.12   POPULATION SECTOR.....	52

CHAPTER 3: MODEL STRUCTURE: MAJOR MECHANISMS AND FEEDBACK LOOPS.	55
3.1 ALLOCATION OF PRODUCTION FACTORS BETWEEN SECTORS.....	56
3.2 AGRICULTURAL SECTOR.....	64
3.3 PRODUCTION CAPACITY IN THE INDUSTRIAL SECTOR..	69
3.4 ALLOCATION OF PRODUCTION CAPACITY IN THE INDUSTRIAL SECTOR.....	75
3.5 ALLOCATION OF INCOME AND CAPITAL ACCUMULATION.	87
3.6 FOREIGN TRADE: IMPORT AND EXPORT MECHANISMS...	93
3.7 OIL EXPORTATION.....	101
3.8 POPULATION STRUCTURE AND CHANGE.....	107
3.9 EDUCATION SECTOR AND GROWTH OF EDUCATION LEVEL	115
3.10 TECHNOLOGY TRANSFER.....	126
CHAPTER 4: ON THE TRANSITION INTO AN OIL-INDEPENDENT ERA: HOW AN ECONOMIC CRISIS MIGHT OCCUR.....	137
4.1 IMPORTANT POLICIES AND ASSUMPTIONS LEADING INTO AN ECONOMIC CRISIS.....	137
4.1.1 OIL EXPORTATION POLICY.....	138
4.1.2 IMPORT REGULATIONS POLICIES.....	138
4.1.3 OIL PRICES.....	140
4.1.4 OIL RESERVES.....	140
4.1.5 LIMITS TO THE GROWTH RATE OF NON-OIL EXPORTS.....	140
4.1.6 IMPORTS SUBSTITUTION.....	141
4.2 THE BASIC RUN: HOW AN ECONOMIC CRISIS MIGHT OCCUR.....	143

4.3	CAN A RISE IN OIL PRICE SOLVE THE PROBLEM?....	153
4.3.1	A 100 PER CENT RISE IN PRICE OF OIL IN 1985.....	153
4.3.2	A 5 PER CENT ANNUAL RISE IN OIL PRICE AFTER 1980.....	156
CHAPTER 5: ON TRANSITION INTO AN OIL-INDEPENDENT ERA: TOWARDS A SMOOTH TRANSITION.....		159
5.1	RESTRICTING IMPORTATION OF CONSUMPTION GOODS..	159
5.2	RESTRICTING IMPORTATION OF FOOD.....	166
5.3	RESTRICTIONS ON GROWTH OF OIL EXPORTS.....	172
5.4	A COMBINATION POLICY.....	180
5.4	A COMBINATION POLICY COUPLED TO AN ANNUAL 5 PER CENT RISE IN PRICE OF OIL.....	184
CHAPTER 6: SUMMARY, CONCLUSIONS AND FURTHER EXTENSION.....		195
6.1	SUMMARY AND CONCLUSIONS.....	195
6.2	FURTHER EXTENSIONS.....	202
APPENDIX A: EQUATIONS DESCRIPTION.....		207
APPENDIX B: MODEL EQUATIONS.....		409
APPENDIX C: INDUSTRIAL CLASSIFICATION.....		427
REFERENCES.....		433



CHAPTER 1  
STATEMENT OF THE PROBLEM

Non-renewable natural resources are valuable assets in many developing countries. These countries can exchange their exhaustible resources for the necessary goods and services that will accelerate the growth and development of their economies. However, rapid economic growth based upon exports of non-renewable resources can lead to increasing dependence on a diminishing resource base. If such an increasing dependency develops, a country would face an economic crisis when its resources run out. Therefore, an important development problem is how to manage a smooth transition of the economy away from dependence on diminishing resources to a state independent of these resources.

This thesis analyzes the management of the transition of the Iranian economy from its present oil-revenues dependency to an oil-independent economy. The study shows that Iran might face a sizable transition problem as oil runs out: GNP, GNP per capita, food per capita, and capacity utilization in the economy could decline substantially during the transition, which is only about 10 to 15 years away. Because

of the importance and magnitude of the transition problem, the design and implementation of policies for a smooth transition requires extensive research and analysis. This study, as one step in such an analysis, suggests some preliminary policies for consideration. The policies and insights resulting from this study could be helpful to Iran as well as to other developing nations who depend on exports of exhaustible resources in general and to oil-exporting countries in particular.

This chapter identifies a problem based on the performance of the Iranian economy since 1959. The following chapters present a System Dynamics model designed to investigate policies for ensuring a smooth transition away from oil-dependency.

## 1.1 INTRODUCTION

Oil revenues give Iran a transitory opportunity for economic growth and development. Oil revenues provide foreign exchange which is necessary to import different goods and services. The revenues increase the government's ability to raise its expenditure and investment in different areas such as infrastructure, education, health, and many other industries and services. The government's expenditure and investment, mostly financed by oil, stimulate the economic growth and industrialization.

Expenditures of oil revenues stimulate domestic demand for consumption goods, services, and food. Although Iran is importing an enormous amount of arms and arms related services, the importation of



conventional consumption goods is restricted to protect domestic producers. Stimulated demand and protection against foreign producers make consumption goods industries attractive to entrepreneurs. The domestic production of consumption goods and services grows rapidly to satisfy demand.

As capacity to produce consumption goods and services rises, so does demand for intermediate goods to feed the growing consumption goods and services industries. Intermediate goods are unfinished goods such as raw materials, steel sheets, parts of automobiles or TV sets or refrigerators which are used by producers of final goods. Domestic output of intermediate goods is far less than sufficient to satisfy demand. In order to facilitate industrialization, the government does not restrict importation of intermediate goods until domestic industries can obtain their required unfinished goods through imports. And, oil revenues provide the necessary foreign exchange. As a result, imports of intermediate goods have been rising rapidly. The dependence of the economy on imported intermediate goods and oil revenues to finance them has been increasing.

Since 1972, the dependence of the country on imported foodstuff also has been increasing rapidly. Domestic agricultural output has not been able to satisfy growing demand for food. Oil money makes the importation of food easily possible. Easily imported agricultural output such as wheat, rice, and meat makes the required food available and decreases incentives to expand agriculture. Imported food increases and

the dependency of the country on imported food and oil revenues to finance it rise.

In addition, economic growth requires machinery and equipment which is currently mostly imported to Iran. Since domestic production of machinery in Iran is far below demand, for years to come, Iran will depend on imported machinery. A growing demand for machinery and equipment would mean a rising demand for imported capital goods. Currently, the sources of finance for imported capital goods, like the financial sources of imported arms, intermediate goods, and food, are oil revenues.

However, since oil is an exhaustible resource, oil revenues will not flow into the country forever. With the current rate of production, Iran's oil reserves will be exhausted in less than 30 years. The present oil revenues can result in an oil-revenue-dependent economic structure in which operation of the economy depends on imported goods (i.e., capital goods, intermediate goods, food, foreign expertise and knowledge). In fact, easily available foreign exchange from oil revenues might raise demand and dependency of the economy on imported goods. In turn, as demand for imported goods increases, oil production should rise to finance increasing imported goods. When oil production increases, the life of oil reserves shortens.

If demand for imported goods and economic dependency on oil revenues continue, when Iran runs out of oil, the country will face serious economic and social problems. When oil is exhausted, foreign

exchange income falls; the country can not then pay for imported food and goods. At the time that Iran runs out of oil, if the country depends on imported food, inability to pay for imports can result in a severe food shortage. Shortage of imported intermediate goods would appear and part of industrial capacity which requires imported intermediate goods can become idle. Lack of foreign exchange makes importing capital goods for new investment or replacement of depreciated capital difficult. Economic growth would suffer. Shortage of food and a drop in economic activities would lead to social stress. All of these problems could happen if Iran's economy continues to depend on oil revenues.

It is very important for Iran to transfer its present oil-dependent economic structure to a healthy oil-independent economy before the country runs out of oil. Development strategies and long-term economic policies should be designed to decrease Iran's dependence on oil revenues. This study is one step in the direction of finding policies to lead the country smoothly into an oil-independent era.

## 1.2 THE PERFORMANCE OF THE IRANIAN ECONOMY FROM 1959 THROUGH 1976

This section reviews the growth of the economy and its major sectors since 1959. The sectors are chosen in a way that their past performances can highlight possible problems that Iran may face in the future.

Gross National Product and Non-Oil Output: Figure 1.1 shows the value of GNP and non-oil output in constant 1972 prices from 1959 through

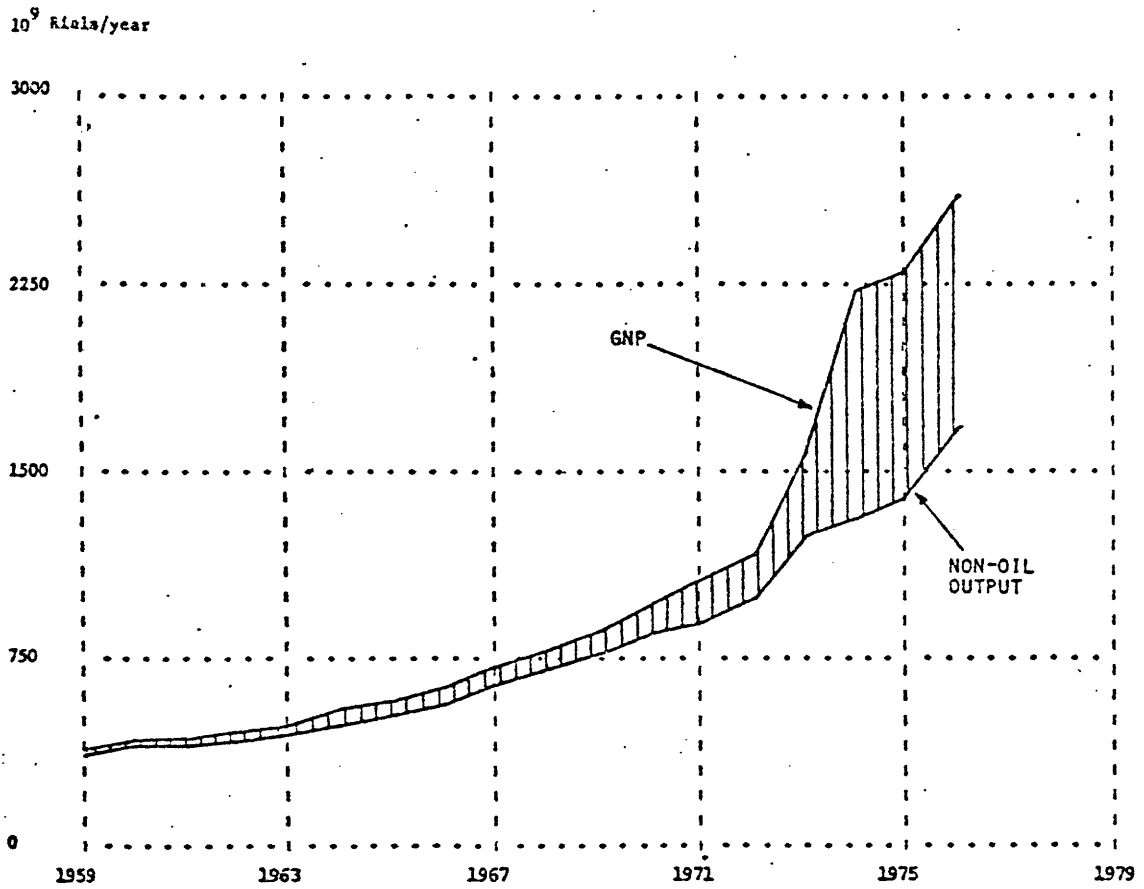

Figure 1.1: The Value of GNP and Non-Oil Output at Constant 1972 Market Prices During 1959 to 1976.

Sources: SRU March 1976, BMAR 2535.

Note: Oil revenues at constant prices are equal to oil revenues at current prices times deflator of imported goods.

1976. During the period, non-oil output grew at 8 percent per year in real terms. Oil revenues have been an important determinant of this high growth rate of non-oil output.<sup>2</sup> As shown in Figure 1.1, the gap between GNP and non-oil output has been increasing since 1959. In fact, the share of oil money in GNP rose from 10% in 1959 to 20% in 1972 and, because of the 1973 price rise, to about 47% in 1973. The gap can not continue to expand forever. Eventually, Iran will run out of oil and the gap will be closed. Iran will pass a transition from a period in which oil revenues are increasing to a period in which they will diminish. If the country can not plan and manage a smooth transition, it will face a sharp fall in oil income. This will cause not only a substantial fall in total GNP and GNP per capita, but also could disturb economic activities in non-oil sectors.

Agricultural Sector: Figure 1.2 shows the growth of indices of per capita GNP and per capital value added in agriculture at constant 1972 prices from 1959 to 1976. The index of value added per capita in agriculture has been relatively constant during the period while the index of per capita GNP rose sharply from 100 to 412. Growth of GNP per capita increases the demand for food per capita. If food production per capita remains constant, demand for food will rise over domestic production. Then, the price of food has to rise in order to encourage agricultural expansion. But, the distribution of income in Iran is very unequal. Table 1.1 shows the distribution of household expenditure in urban areas. In 1973-74, 50 percent of households account only for 17.04

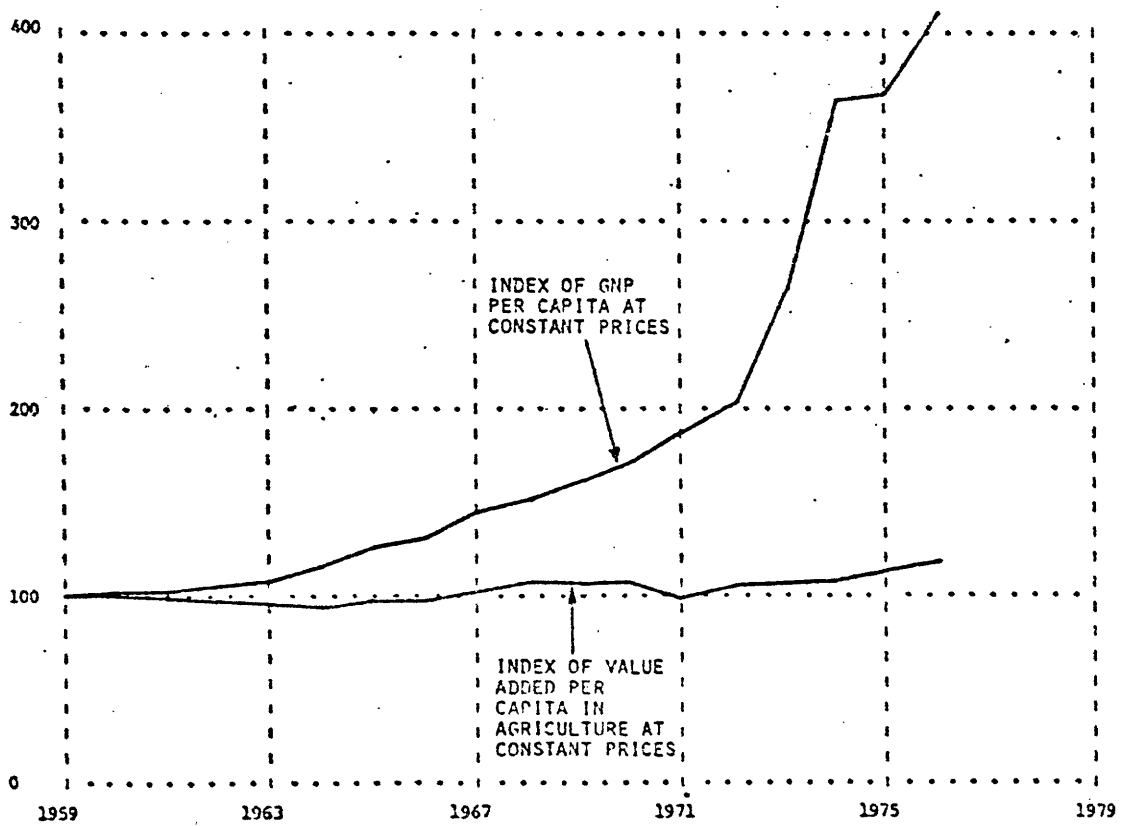

Figure 1.2: Indices of GNP Per Capita and Value Added Per Capita in Agriculture at 1972 Constant Prices.

Sources: Prepared based on information in SRU March 1976 and BMAR 2535.

Table 1.1  
Decile Distribution of Household Expenditure - Urban Areas  
(percent)

Deciles (lowest to highest)	1959- 1960	1969- 1970	1970- 1971	1971- 1972	1972- 1973	1973- 1974
1st	1.77	1.59	1.48	1.34	1.37	1.37
2nd	2.96	2.86	2.62	2.39	2.51	2.40
3rd	4.09	3.96	4.07	3.60	3.36	3.42
4th	5.08	4.58	4.54	4.32	4.64	4.77
5th	6.17	5.94	5.60	5.66	5.16	5.08
6th	7.37	7.96	7.68	6.94	6.98	6.85
7th	8.92	8.48	8.23	8.57	9.51	9.36
8th	11.85	11.72	11.48	11.70	11.14	11.19
9th	16.42	16.05	11.48	11.70	11.14	11.19
10th	35.37	36.86	38.12	39.48	36.95	37.99

Source: M. H. Pesaran (1976), p.278.

percent of total household expenditures. The low income group of population can not tolerate high increases in food prices. Food imports have to increase the total food supply in order to keep the prices at an acceptable level. As long as foreign exchange from oil revenues is available, the necessary food can be imported to satisfy demand. As Figure 1.3 shows, in recent years, imports of food have increased rapidly.

The ready availability of imported food decreases pressure to expand the agricultural sector. The agricultural sector does not grow sufficiently to keep up with demand. As GNP and population grow, the

demand for imported food rises. Exports of oil are likely to increase to pay for imported food as long as oil is available. But when the country runs out of oil, foreign exchange scarcity could appear. As a result, Iran will have difficulty in importing food. A shortage of food might generate serious economic and social problems.

Consumption Goods and Services Sector: The growth of GNP increases the demand for consumption goods and services. Oil revenues, which are a substantial part of GNP, could increase consumption expenditures above domestic supply of consumer goods and services.

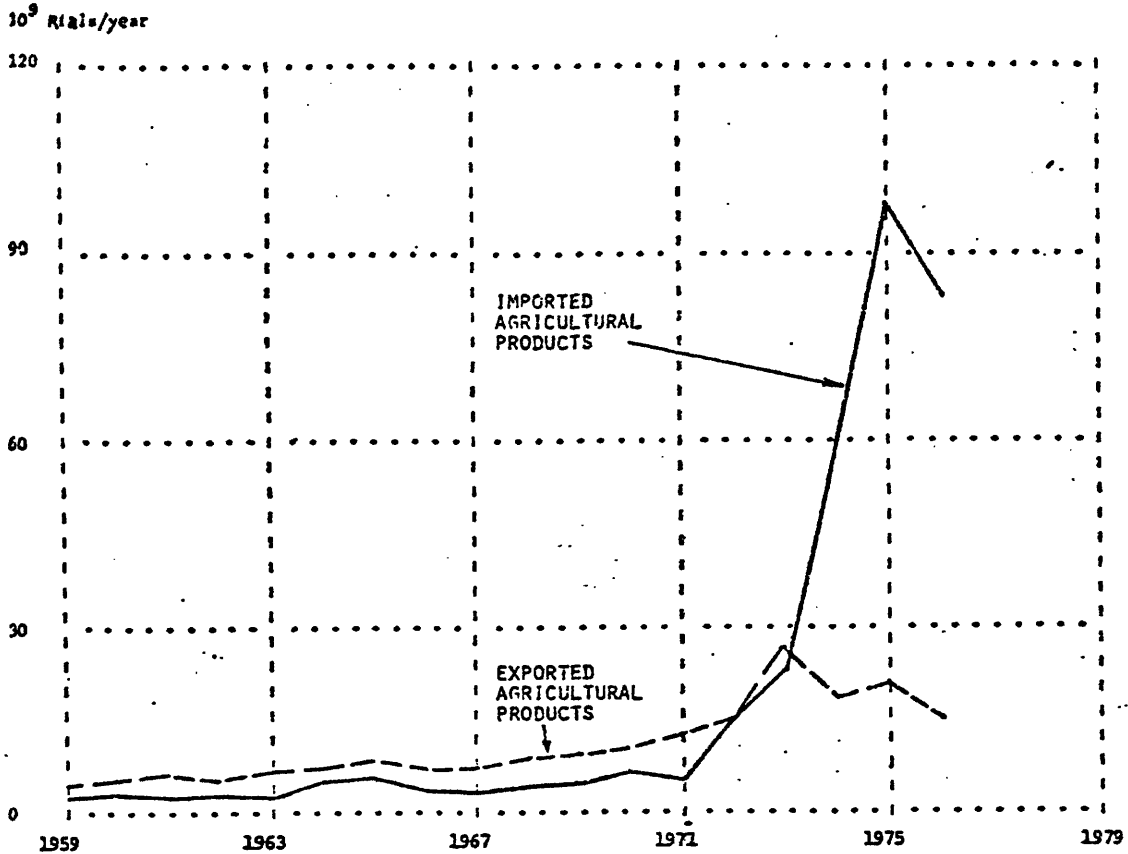

Figure 1.3: Imports and Exports of Agricultural Products at Current Prices.

Sources: BMAR different issues.



Figure 1.4 shows total expenditures on non-food consumer goods and services as well as their domestic supply. The gap between total expenditures and domestic supply is the total net imports of consumer goods and services. The gap consists of (1) the net imports of conventional consumer goods such as cars, radios, refrigerators, clothing, etc., and (2) the net imports of services and miscellaneous consumption goods including arms.

Although no trade regulations exist on the importation of services and arms by the government, quotas and high tariffs to a large extent restrict imports of conventional consumer goods. Restrictions on the importation of consumption goods aim to protect the domestic industries and encourage industrialization. High demand for consumption goods and import restrictions make the consumption goods sector profitable combined with attractive to entrepreneurs. The sector becomes very competitive in hiring the production resources of the nation. Other production sectors such as agriculture, capital and intermediate goods sectors can hardly compete with the consumption goods sector in hiring production resources. While the consumption goods sector grows fast to satisfy domestic demand for conventional consumer goods and services, the scarcity of production resources, such as skilled labor, for the other sectors rises. The growth of the other sectors becomes more difficult.

Intermediate Goods Sector: As the economy grows, so does the demand for intermediate goods. Intermediate goods are unfinished goods which are used by the producers of final goods. All inputs to the

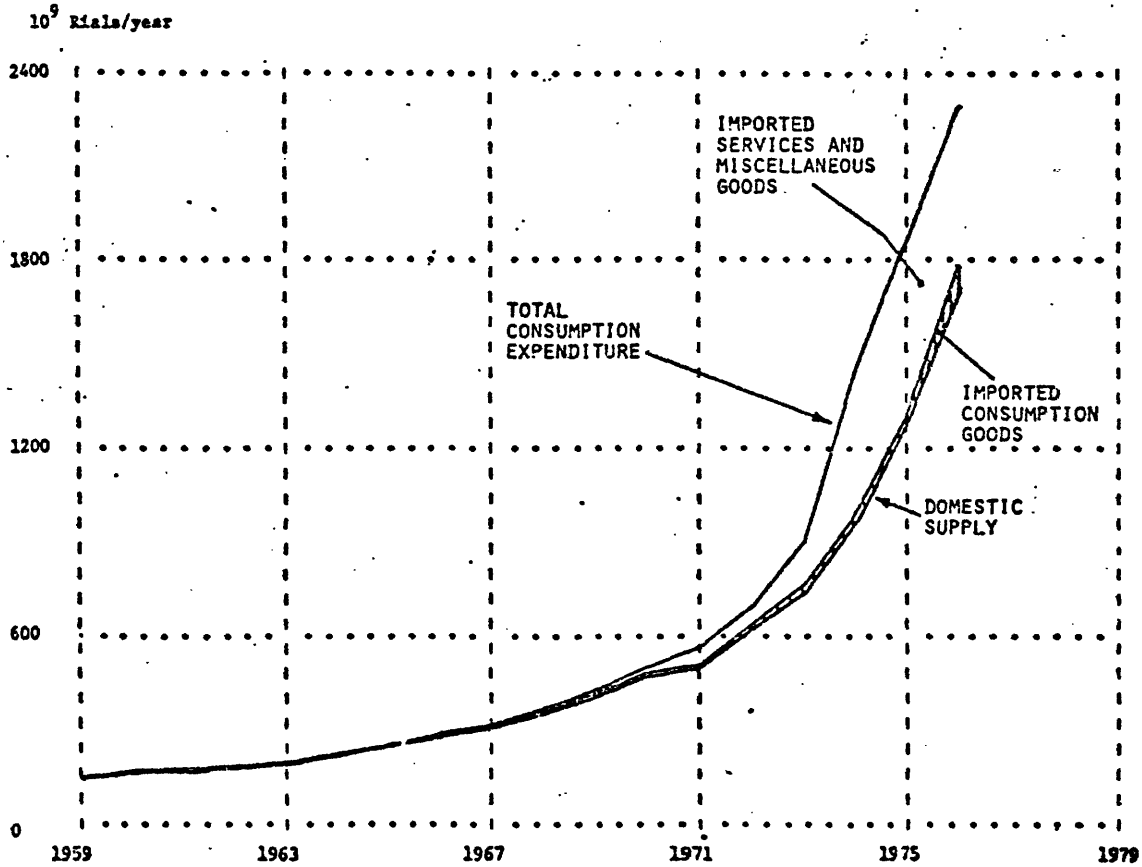

Figure 1.4: Total Consumption Expenditure and Domestic Supply of Non-Agricultural Goods and Services at Current Prices.

Sources: Prepared based on data from SRU March 1976 and BMAR, different issues.

Note: The imports of services and miscellaneous goods, including arms, are determined as the difference between total foreign exchange payment for imports of goods and services and total imports of food, consumption, capital, and intermediate goods after 1965 when the difference is positive. This calculation is clearly an approximation which is used because no reliable data on imports of arms could be found.

factories producing final goods such as cars, TV sets, radios, air conditioners, etc. are intermediate goods. Figure 1.5 shows the growth of total intermediate goods utilized by the economy, domestic supply, and imported intermediate goods. Domestic production does not catch up with the demand for intermediate goods. The imported intermediate goods are necessary to satisfy demand of domestic industries.

The importation of the necessary intermediate goods is not restricted in order to facilitate the growth of domestic industries that demand intermediate goods. When foreign exchange (through exporting oil) is available, the country easily imports the required intermediate goods. The imports of intermediate goods have been rising rapidly.

The imports increase the availability of intermediate goods. As availability increases, pressures to expand the intermediate goods sector decrease. The production capacity of the sector does not increase as rapidly as the demand for intermediate goods. As the availability of imported intermediate goods slows down the growth of the intermediate goods sector, the availability of production factors to the highly stimulated consumption sector increases and the growth of that sector accelerates. As the production capacity of the consumption goods sector increases, its demand for intermediate goods increases. And, as long as foreign exchange is easily available, imports of intermediate goods rise. And thus, the dependency of the economy on imported intermediate goods increases.

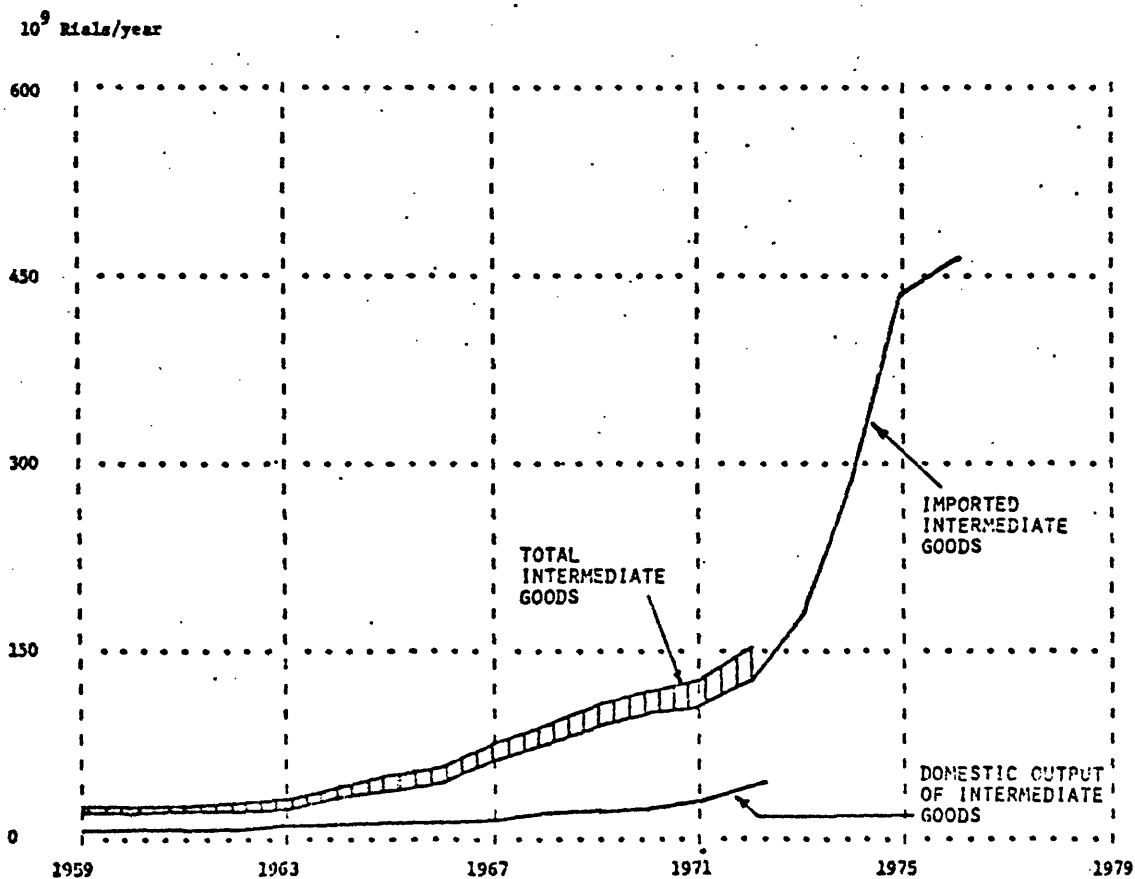

Figure 1.5: Growth of Domestic and Imported Intermediate Goods at Current Prices.

Sources: Prepared based on data in Ministry of Industry and Mines, Iranian Industrial Statistics 1972; Bank Markazi Iran, National Income of Iran 1959-1965; BMAR different issues.

Note: For classification of industries to consumption goods, intermediate goods, and capital goods industries, see Appendix C.

As the demand for imported intermediate goods rises, so does the foreign exchange required for these goods. Oil revenues, the main source of foreign exchange income, should therefore rise. But as oil production increases, depletion of oil reserves quickens. If the process continues, then when oil resources are exhausted, foreign exchange availability will drop and a scarcity of intermediate goods will appear. The economy would then be unable to get its required intermediate goods. Output of the industrial sector will drop, idling some production capacity.<sup>3</sup>

Capital Goods Sector: An economy grows by increasing its factors of production. One of the important production factors is capital equipment. The stock of equipment in the economy increases through investment in domestic and imported capital goods. Figure 1.6 shows total capital goods sold each year in Iran, domestic supply as well as imported capital equipment. The domestic output of capital equipment has been mostly transport equipment such as busses, trucks, and mini-busses.

Since domestic production of capital goods can not satisfy rapid growing demand for capital equipment, the imported capital goods should rise. In order to facilitate investment and encourage industrial expansion, no trade restrictions such as tariff or quotas exist on importation of capital goods. As long as foreign exchange is available, the required capital goods can be easily imported to satisfy demand. And, since oil revenues provide the necessary foreign exchange, the imports of capital goods have been rising rapidly.

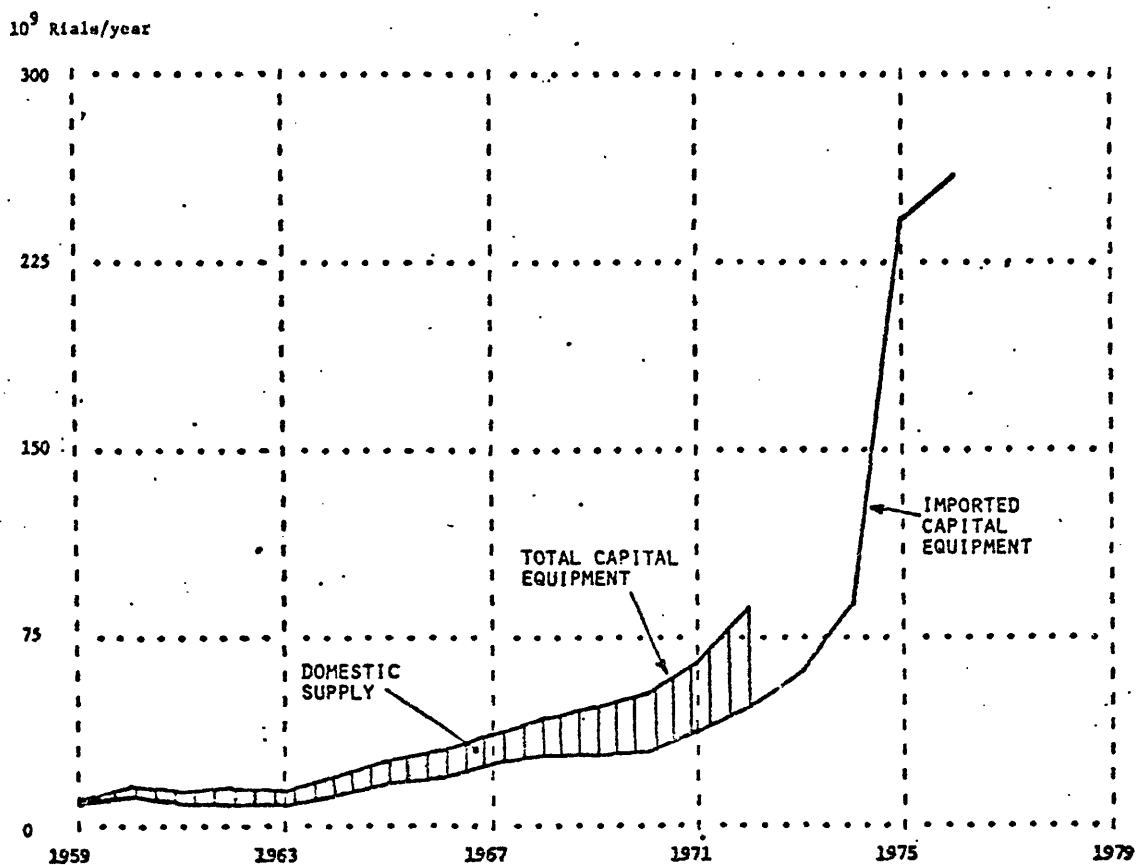

Figure 1.6: Total Capital Equipment, Domestic Supply and Imported Capital Goods.

Sources: BMAR different issues; Ministry of Industry and Mine, Iranian Industrial Statistics 1972.

Easily imported capital goods increase the availability of capital equipment in the country. As the availability of capital goods increases, pressures to expand the sector decrease. Low pressures to expand the sector as well as the lack of experience in the production of capital goods slow down the expansion of the sector. Therefore, as the economy grows, demand for imported capital goods increases. Increasing demand for imported capital goods raises the required foreign exchange and intensifies pressures to increase oil production. As a result, exportation of oil increases. Growth of oil exports, in turn, facilitates importation of capital goods, increases the dependency of the economy on imported capital goods, and accelerates depletion of oil reserves. The increasing dependency of the economy on imported capital and oil revenues could lead the county into a severe capital equipment scarcity when oil runs out.

Education: Education is essential to economic growth and development. An illiterate labor force can not understand and apply new production techniques to increase economic output. As a survey by M.S. Bowman (1966) shows, the contribution of education to economic growth is well recognized by economists.

In Iran, the education level of people is low and illiteracy is high. In 1972, 5 million out of 7.6 million members of the work force were illiterate.<sup>4</sup> The education sector which provides education has not expanded satisfactorily in the past. In 1970, the ratio of enrolled students to school-age children was 53.4% for primary schools and 26.2%

for high schools.<sup>5</sup> For economic development, it is essential for Iran to expand its education system and to increase the level of education in the country.

The expansion of the education sector requires production resources. The most important production resources for the expansion of the sector are educated people. When oil-revenues stimulate the economy, educated people and all other production factors are in high demand by the production sectors. If the government does not help to ensure that the education system is able to hire its required resources, the growth of the sector might suffer. As a result, the present shortage of professionals and educated people in Iran discussed by F. Aminzadeh (1976) would continue. Hence, the growth of production capacity of the nation would slow down.

Population: People carry out development and the ultimate objective of development is people's well-being. Population produces the labor force, a classical factor of production in economics literature. However, in Iran, as in other developing countries, labor is not a limiting factor of production. Lack of knowledge and skill embodied in the labor force is limiting the production capacity of the nation. Nevertheless, the labor force increases as population grows.

As development takes place, the standard of living and health services increase; death rate and mortality fall; the rate of growth of population rises until further development decreases birth rates and



reduces the rate of growth of population. In Iran, population grew from 21 million in 1959 to 32.5 in 1974, with an average annual growth rate of 2.88%.<sup>6</sup> With this growth rate, the population will reach 68.7 million by the year 2000.

As population grows, so does the demand for food, goods, and services. Oil reserves permit demand to go far beyond the production capacity of the nation. Growth of population increases the demand for imports and the required oil revenues to finance the imports. Exports of oil increases, accelerating the exhaustion of oil reserves. When oil runs out, the country might end up with a large population, around 60 million, without sufficient food, goods, and services to sustain their standard of living. In long-term economic planning, the growth of population and its impact on economic growth and development should be of major concern.

The Role of Oil Revenues in Foreign Trade of Iran: Figure 1.7 shows the composition of total imports since 1959. As total imports grow, total exports should also grow to pay for the imported goods. Figure 1.8 depicts total exports of the country. As shown in Figure 1.8, the gap between total exports and non-oil exports is increasing dramatically. As the share of oil money in the balance of payments increases, so does the dependency of the economy on oil revenues. However, the country can not rely on oil revenues forever.

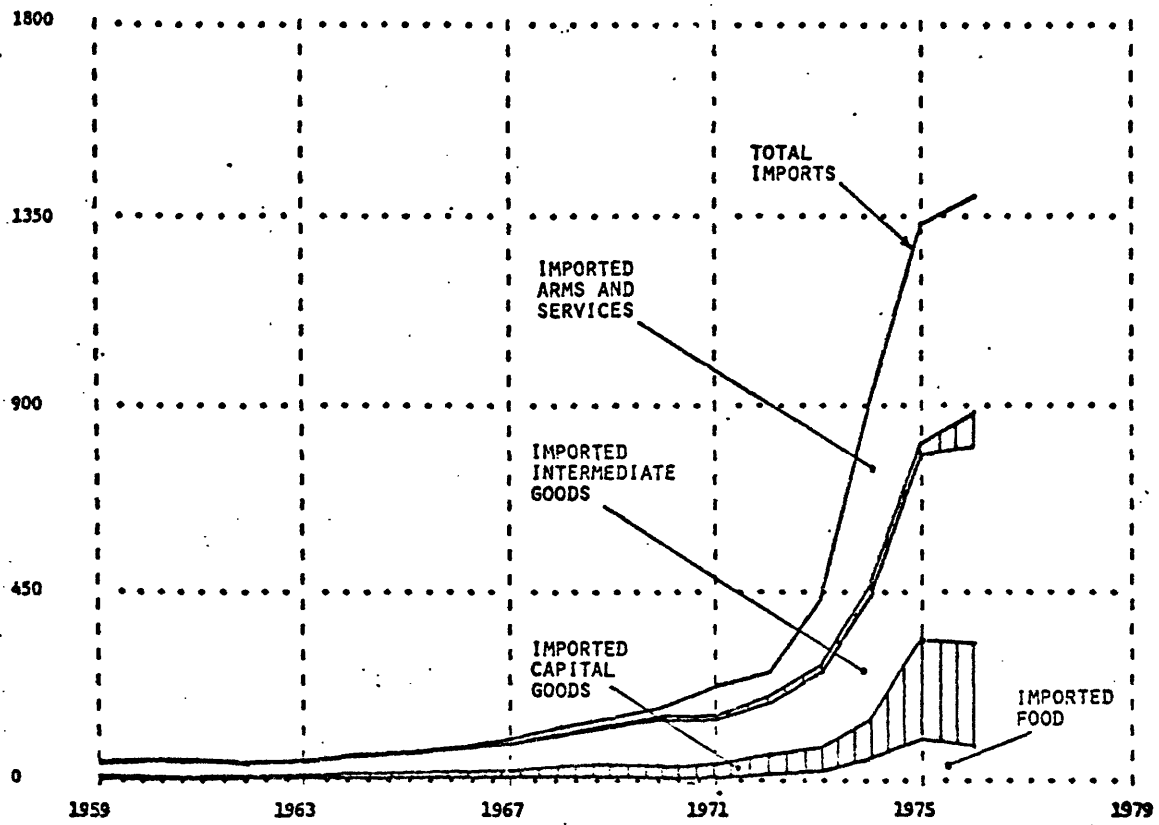

Figure 1.7: Total Imports by its Composition at CIF and Current Prices.

Sources: BMAR different issues.

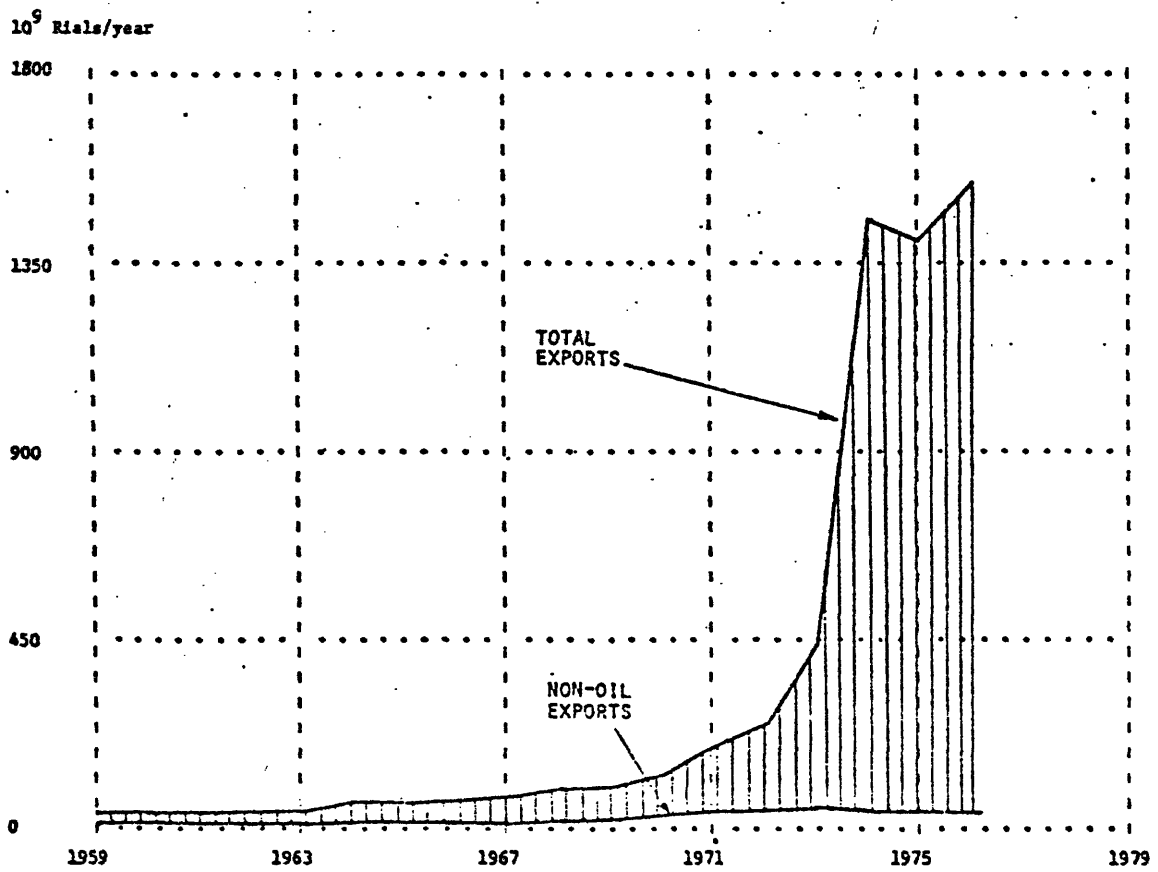

Figure 1.8: Total Exports and Non-Oil Exports at F.O.B. and Current Prices.

Sources: EMAR of different years.

Figure 1.9 shows total oil production, domestic consumption, and oil reserves in Iran since 1959. Proven oil reserves in Iran are estimated to be 63 billion barrels at the end of 1976.<sup>7</sup> Assuming a 1976 rate of production, 2.153 billion barrels per year, proven reserves will last for less than 30 years. However, if oil production continues to increase, the life of reserves will shorten. The oil reserves will fall rapidly while the domestic demand for oil increases fast in the rapidly growing Iranian economy. The rapid growth of domestic demand for energy, on the one hand, and the accelerating depletion of oil reserves, on the other hand, point to the possible oil shortage in Iran in the next two or three decades. Future sufficiency of oil for domestic demand and the transition from an increasing dependency on oil to an oil-independent economy should be of a great concern to Iranian planners.

### 1.3 A POSSIBLE CRISIS

Iran really does not have too much time to reverse the trend of its increasing dependency on oil revenues before it runs out of oil. As Hammeed and Bennett state: "The coming 20 years or so will be crucial and unique in the economic history of Iran."<sup>8</sup> Without preparation for a smooth transition to an oil-independent era, exhaustion of oil reserves could lead to a foreign exchange scarcity. A foreign exchange scarcity makes importation of food, intermediate goods, and capital goods difficult. As a result, food shortages might appear; due to an

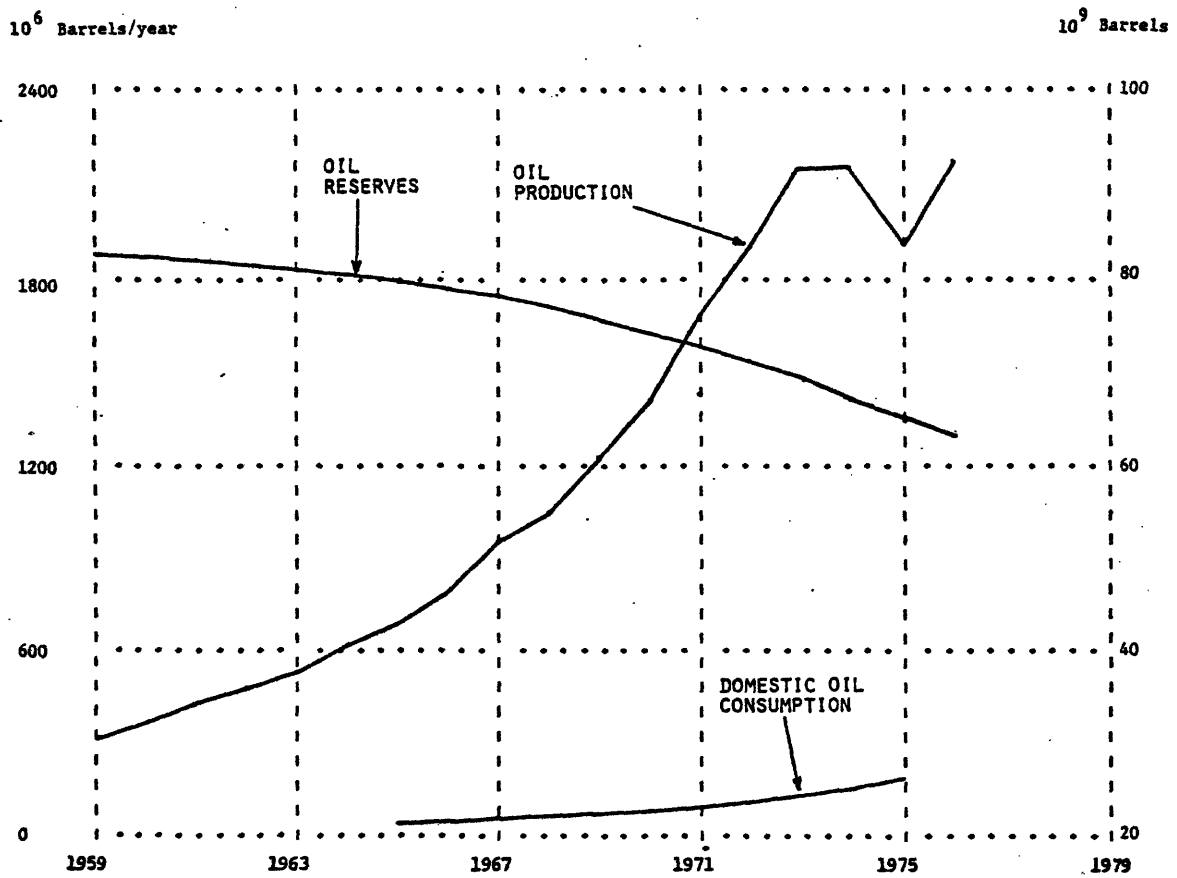

Figure 1.9: Total Oil Production, Domestic Oil Consumption, and Proven Oil Reserves in Iran Since 1959.

Sources: DeColyer and MacNaughton (1976), p.1 and p.9; BMAR 1349, pp. 173-174; OPEC Annual Review and Record, 1976.

inadequacy of intermediate goods, production capacity might become idle; and a lack of capital goods, for replacement and new investment, could stall the growth of the capital stock in the economy. All of these possibilities necessitate a careful analysis and design of economic development in Iran for the next two decades. Otherwise, as oil runs out, under certain policies which will be discussed in Chapter 4, Iran might face an economic crisis like what is shown in Figure 1.10

Figure 1.10 shows GNP, non-oil output, GNP per capita and food per capita, all at 1972 constant prices, and an indicator of foreign exchange availability in Iran from 1960 through 2010. The figure is an output of a System Dynamics model of the Iranian economy. The model and its behavior will be fully described in the later parts of the thesis.

In Figure 1.10, the gap between GNP and non-oil output represents oil revenues. The gap widens until 1984. Since oil reserves are limited, oil exportation can not continue for ever. The gap decreases after 1984. When growth of oil revenues slows down, foreign exchange availability falls, indicating the appearance of a foreign exchange shortage. Owing to foreign exchange shortage, the country can not import its required capital and intermediate goods. The growth of non-oil output slows down and then stagnates for about 10 years after 1987. Because oil revenues are falling, while non-oil output is stagnating, the sum of the two, GNP, falls after 1987 for about one decade.

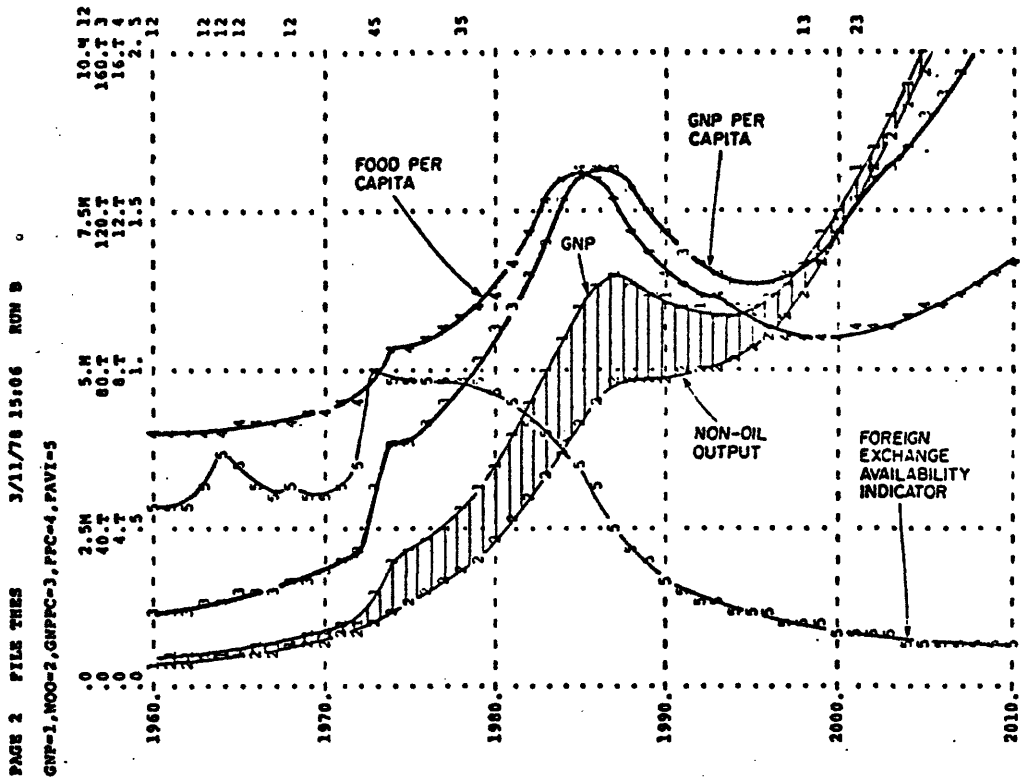

Figure 1.10: An Economic Crisis During the Transition.

When GNP falls, GNP per capita drops even more drastically due to the growth of population (not shown on the figure). The foreign exchange shortage, which starts in the early 1980's, decreases food importation, which is also not shown on the figure. As a result, after 1984, food per capita falls, too.

The behavior of all the variables in Figure 1.10 indicate a serious economic and social crisis that Iran might face. No country would like to simultaneously face a foreign exchange shortage, a drop in GNP per capita, food per capita, GNP and non-oil output, which is correspondent to an enormous rate of unemployment. If such a crisis occurs, Iran would need a long time to recover from that. In fact, in Figure 10.1, it takes 20 years for GNP per capita to reach the same level as in 1986.

This thesis is concerned with the development strategies which prevent a possible crisis, like that shown in Figure 1.10. The thesis aims to explain how a possible crisis could occur and to find development policies which prevent such a crisis. In the thesis, a System Dynamics model is designed as a vehicle to analyze different development strategies. The following chapters, as outlined in the next section, will present the model, its behavior, and some policy analysis.



#### 1.4 PREVIEW OF THE FOLLOWING CHAPTERS

##### Chapter 2: General Overview of the Model.

Chapter 2 aims to give a general overview of the model developed in the study to address the problem stated in Chapter 1. The chapter gives an overview of the model structure and presents the major components and sectors included in the model. It explains the function and relevance of each sector and component in the model.

##### Chapter 3: Model Structure: Major Mechanisms and Feedback Loops.

Chapter 3 will explain the theoretical foundation of the model. The chapter provides general information for understanding how the model works. Chapter 3 describes the major mechanisms and feedback loops in the system that govern the model behavior (without getting into the details of the equations). The chapter is written to help technical and/or non-technical readers to understand the analysis of the behavior in the next two chapters. A detailed description of the equations and parameters value will appear in the appendix.

##### Chapter 4: On the Transition into an Oil-Independent Era: How an Economic Crisis Might Occur.

Chapter 4 will explain the behavior of the model, showing that Iran might face a severe economic crisis as it begins to run out of oil

less than 15 years from now. The behavior of the model will be analyzed in terms of some policies with respect to foreign trade restriction and oil exports that would lead the country into a crisis.

Chapter 5: On the Transition into an Oil-Independent Era: Towards a Smooth Transition.

Chapter 5 attempts to design appropriate policies for a smooth transition into an oil-independent era. The chapter examines some of the different alternative policies such as: restriction on importation of consumption goods and food; restriction on exportation of oil to increase the life span of the oil reserves; and a combination of these policies.

Chapter 6: Summary, Conclusion and Further Extensions.

Chapter 6 will conclude the study and summarize the results. The chapter should also point out some of the important issues which are not considered in the model.

Appendix A: Equation Description.

The appendix will contain a full description of the model equations, parameters value, and table functions.

Appendix B: Model Equations.

Appendix B contains a complete listing of the equations in the model.

Appendix C: Industrial Classification.

Appendix C presents a list of mining and manufacturing activities classified into consumption goods, intermediate goods, and capital goods industries.

FOOTNOTES

<sup>1</sup>Since 1959, rial equivalent of each dollar has been between 75 to 66 rials/dollar.

<sup>2</sup>For the way that oil revenues were used in the economic development of Iran, see Bharier (1971), and Amuzegar and Feckrat (1971).

<sup>3</sup>Idle capacity in the industrial sector due to lack of intermediate goods, for example, was experienced by India during 1960-1966. During that time, due to the foreign exchange shortage, India was not able to import its required foreign intermediate goods (see Bhagwati and Srinivasan, 1975).

<sup>4</sup>For literacy of the labor force, see Plan & Budget Organization, Statistical Center, 'A Survey of Manpower in 1972', in Farsi, Mordad 1353, p. 86.

<sup>5</sup>For enrollment ratios, see BMAR 1349, p. 184.

<sup>6</sup>For population statistics of Iran, see SRU March 1976, Table 76.

<sup>7</sup>For oil reserves statistics, see Oil & Gas Journal, December 27, 1976; DeGolyer and MacNaughton (1976); or OPEC Annual Review and Record 1976.

<sup>8</sup>Kamal A. Hammeed and Margaret N. Bennet (1975).

## CHAPTER 2

### GENERAL OVERVIEW OF THE MODEL

A System Dynamics model has been developed to analyze the transition of the Iranian economy into its oil-independent era. This chapter presents a general picture of the model structure and its major components and sectors with some of their interactions. The chapter also explains the function and relevance of each sector. Although familiarity with System Dynamics is not essential to follow the problem and its analysis in this thesis, such familiarity is certainly helpful. Available text books in System Dynamics methodology are Forrester (1968), Forrester (1961), Goodman (1974), and Alfeld et al. (1975).

Figure 2.1 shows the major sectors and components of the model plus some of their interactions. The sectors are identified and chosen in relation with the problem described in Chapter 1. The level of aggregation and the boundary of the model can be perceived, to some extent, both from Figure 2.1 and the following description of each component. A detailed discussion of the interactions in form of feedback mechanisms appears in Chapter 3. Appendix A explains the equations representing the exact relationships in the model.

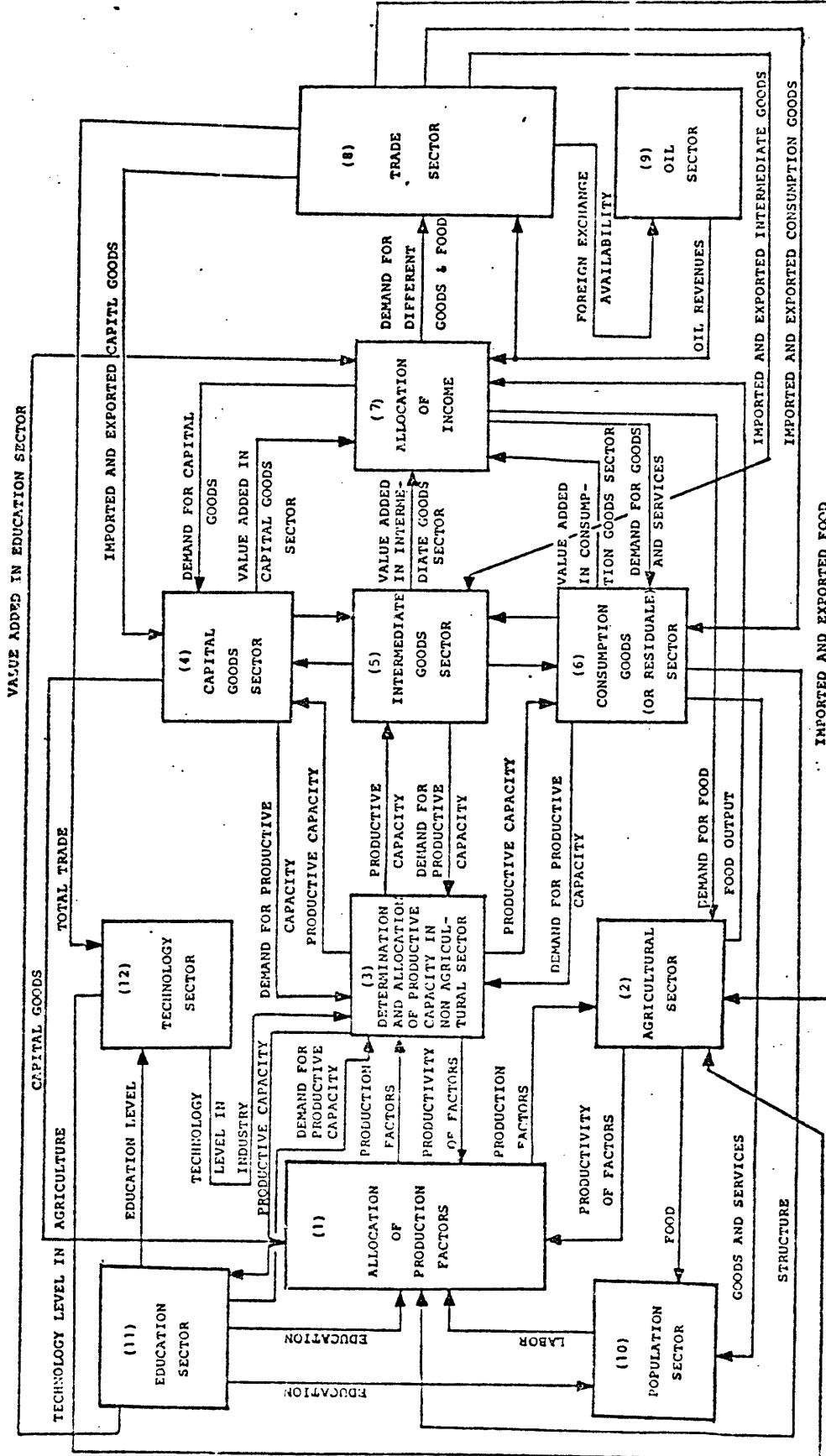

Figure 2.1: The Major Components of the Model with Their Interactions.

## 2.1 ALLOCATION OF PRODUCTION FACTORS

Three aggregate production factors are considered in the model: capital, labor, and education level (measured in man-years of schooling). Capital and labor are conventional production factors considered in economic growth models, while education level is not usually considered as a growth determinant in such models.<sup>1</sup>

However, the importance of education to economic growth and development has been well recognized in the economic literature. For example, Horbison and Meyers (1964) show a strong correlation between GNP per capita and the level of education in different countries. The works of Denison (1962, 1967) show that improvement in the education level of the labor force is a significant determinant of economic growth compared with accumulation of capital and growth of labor force. According to Denison's work, in the United States during 1950-1962, improvement in education of the labor force contributed 15.1% to the growth of output; while the contribution of labor force excluding education was 18%, and the contribution of capital accumulation was 25%. The same significance has been observed for the contribution of education to the growth of other advanced countries. Because of the importance of education to growth of output, the model considers educational level of the country as one of the production factors - like labor and capital - determining total output.

The production factors are supplied by different sectors, as shown in Figure 2.1. The population sector provides labor. Capital is the accumulation of investment from both domestic and imported capital goods. Graduates from the education sector increase the educational level. The three production factors are then allocated between agricultural and non-agricultural sectors of the model.

The allocation of each production factor to a sector is based on the productivity of that factor in the sector and availability of the sector's output. Availability of output is a measure of demand relative to supply when both demand and supply are measured in real terms. When availability of, say, non-agricultural goods and services is low - i.e., real demand exceeds real supply - more production factors are allocated to non-agricultural sectors and vice versa.

## 2.2 AGRICULTURAL SECTOR

The agricultural sector produces food. Chapter 1 suggests that when Iran runs out of oil, the country might face a food shortage. Hence the agricultural sector should be considered as an important sector in a long-run analysis.

The production factors (labor, capital, and education) allocated to the agricultural sector, the level of technology in agriculture and the amount of agricultural land in the country determine the agricultural output through an aggregate production function. Domestic food output



and net imported food determine total food supplied to the population sector as shown in Figure 2.1. Expansion of the sector depends on food availability, a measure of demand for food relative to total supply. The sector expands when food availability drops, and vice versa.

### 2.3 DETERMINATION AND ALLOCATION OF PRODUCTION CAPACITY IN THE NON-AGRICULTURAL SECTORS

The production factors allocated to non-agricultural sectors and the level of technology determine total production capacity in the non-agricultural sectors through an aggregate production function. This production capacity represents total production capability of the nation outside the agricultural sector. As shown in Figure 2.1, the production capacity of non-agricultural sectors will be allocated among the capital goods sector, the intermediate goods sector, the education sector, and the consumption goods sector representing all other non-agricultural and non-oil production activities.

Production capacity allocated to each sector depends on desired production capacity in that sector relative to total desired production capacity in all non-agricultural sectors. When desired production capacity in a sector relative to total desired production capacity increases, so does production capacity allocated to that sector. Desired production capacity in each sector, determined within the sector, is an information output of that sector, as shown in Figure 2.1.

## 2.4 CAPITAL GOODS SECTOR

The capital goods sector represents producers of capital equipment. As discussed in Chapter 1, capital equipment used in Iran is mostly imported, demanding part of the foreign exchange revenues of the country. At the time that Iran runs out of oil, if a foreign exchange shortage appears, the import of capital goods may decrease. If the domestic capital goods sector cannot produce adequate capital goods, lack of capital equipment slows down economic growth. Therefore, it is important to include capital equipment producers in the model.

The capital goods sector holds a part of the production capacity of the nation. When the production capacity of the sector rises, so does its output if the necessary intermediate goods are available to be used by the sector. The sector's production capacity increases when its desired production capacity rises. Desired production capacity of the sector depends on availability of capital equipment, productivity, and capacity utilization in the sector plus governmental policies with respect to sectoral development and imports substitution. When availability of capital goods drops, or productivity in the sector rises, or capacity utilization increases, desired production capacity in the sector rises, and vice versa.

## 2.5 INTERMEDIATE GOODS SECTOR

The intermediate goods sector represents producers of semi-finished goods which are used as inputs to production of final goods

(i.e., capital goods, consumer goods and services). Intermediate goods are supplied both domestically and through importation. A shortage of intermediate goods can make productive capacity of other sectors idle. Availability of intermediate goods depends on both domestic production and ability of the country to import them. Because availability of intermediate goods is crucial to operation of other sectors, growth of domestic supply of intermediate goods is quite important.

The domestic supply of intermediate goods increases when the production capacity allocated to the sector rises. The sector's production capacity increases when desired production capacity in the sector rises. Desired production capacity of the sector depends on availability of intermediate goods, productivity and capacity utilization in the sector, plus governmental policies with respect to sectoral development and imports substitution. When availability of intermediate goods drops or productivity in the sector rises, or capacity utilization in the sector increases, desired production capacity in the sector rises, and vice versa.

## 2.6 EDUCATION SECTOR

This sector provides education, which increases labor productivity. Education is an important determinant of the capability of the nation to adopt new technology and to expand its production capacity. Education level also influences demographic behavior of the population. Therefore, the education sector, which raises the poor

education level in Iran and supports future development of the country, is an important sector in the development process.

Outputs of the education sector are graduates, whose level of education is measured in man-years of schooling. Education embodied in graduates accumulates in the total level of education, which is a production factor in the model. Output of the sector increases as the capacity of the education sector and demand to utilize that capacity, both endogenous to the model, rise. Demand for education is an increasing function of the average education of adult population and income per capita in the country. Educational capacity is the amount of production capability of the nation allocated to the sector. Production capacity in the education sector increases, subject to governmental policies regulating educational expansion, when demand for education rises.

## 2.7 CONSUMPTION GOODS SECTOR

The consumption goods sector represents producers of consumer goods, services, and construction. The sector in the model contains all other non-agricultural producing sectors excluding the capital and intermediate goods, education and oil producing sectors of the model. Domestic output plus net imports of consumption goods and services provide available goods and services to be consumed by the nation.

Output of the consumption goods sector increases when production capacity allocated to the sector rises and the necessary intermediate goods to be used by the sector are available. The sector's production capacity rises when its desired production capacity increases. Desired production capacity of the sector depends on availability of consumption goods, productivity, and capacity utilization in the sector plus governmental policies with respect to sectoral development and imports substitution. When availability of capital goods drops, or productivity in the sector rises, or capacity utilization increases, desired production capacity in the sector rises, and vice versa.

## 2.8 TECHNOLOGY SECTOR

The technology sector simulates the technological progress in the economy. Technological progress is a determinant of economic growth. Technological progress represents improvement in the process of production, in the quality of capital equipment, in technical and managerial know-how, and in the ability of social and political organizations to increase economic output. Technological progress in Iran is achieved mostly through transfer of already developed technology from industrialized countries.

The rate of technological transfer is formulated on the basis of two factors. The first is the amount of available technology in the technologically advanced countries not utilized by Iran. The second is the ability of the nation to transfer that technology. The capability of

the country to transfer technology depends upon the average education level of its workforce and upon foreign trade. As the education level of the labor force increases, so does its ability to understand and implement new technology. Foreign trade can also stimulate technological transfer by increasing the flow of technical information between nations via flow of certain goods and services, direct contact between people of countries with different levels of technology, and purchase of licenses and patents.

## 2.9 ALLOCATION OF INCOME

The nation allocates its total income to demand food, consumer goods and services, and investment goods. This section of the model generates demand for various final goods, based on total income and population. Total income is the summation of the incomes from the agricultural, capital goods, intermediate goods, consumption, and oil sectors. Demand for each item as a fraction of total income varies as per capita income changes. For example, as income per capita rises, the fraction of total income spent on food drops although total expenditures on food rises. In this sector, total income and population, through aggregate demand functions, determine demand for food, consumer goods and services, and investment goods. The demand functions reflect the variation of the fraction of total income allocated to demand various final goods as per capita income increases. The demand for final goods

is satisfied either by domestic production or importation. The final demand, together with importation policies, shape the pattern of sectoral development in the economy.

## 2.10 TRADE SECTOR

Imbalance between demand and supply in different sectors may be adjusted through foreign trade. The trade sector of the model determines imports and exports on the basis of domestic production, domestic demand, foreign exchange availability, and governmental policies regulating trade. By providing differential protection to the various production sectors of the economy, the trade policies can have a strong influence on the pattern of sectoral development and hence, on the nature and magnitude of the problem that Iran may face as oil reserves diminish. The trade policies included in this sector of the model are important elements in designing an appropriate development strategy for Iran.

## 2.11 OIL SECTOR

The oil sector contains oil resources. The sector produces and exports oil to provide foreign exchange. Although the value of oil output is a major part of GNP, the sector uses a very small fraction of the total production factors of the country. In 1974, the oil sector employed only 0.5% of the total labor force<sup>2</sup>; and from 1965 through 1974, 8.8% of the total Gross Domestic Capital Formation was invested in

the oil sector<sup>3</sup>. For simplicity, therefore, the model ignores the necessary production factors in the oil sector. Governmental policies determine oil production and exportation. Because of the current importance of oil revenues to development in Iran, and because of the increasing dependence on those revenues, the oil exportation policy needs careful examination in the study.

## 2.12 POPULATION SECTOR

The demographic sector is one of the important sectors in most studies of economic development. The sector, on the one hand, provides labor for the economy, and on the other hand, claims the output of economic activities. Population is endogenous to the model. Population is increased by birth rate and decreased by death rate. Birth rate depends on the size of adult population, food per capita, level of industrialization indicated by industrial output per capita, and educational level of population. While growth of food per capita increases birth rate, industrialization and improvement in education level decrease birth rate. Death rate, in the model, depends on industrialization and food per capita. Both growth in food per capita and industrialization decrease death rate.



FOOTNOTES

<sup>1</sup>For a collection of economic growth models see Joseph E. Stiglitz and Hirofumi Uzaw (1969), and Amartya Sen (1974).

<sup>2</sup>For employment in different sectors of the economy, see SRU March 1976, Table 77.

<sup>3</sup>For capital formation in different sectors, see SRU March 1976, Table 51.



### CHAPTER 3

#### MODEL STRUCTURE: MAJOR MECHANISMS AND FEEDBACK LOOPS

The major sectors and components, outlined in the last chapters, are linked by feedback relationships. The dynamics of the system result from these relationships. To understand the system's behavior, it is necessary to identify its major feedback structures. Each structure in the model is a theory about a set of real world economic activities, relevant to the problem under study.

This Chapter serves two purposes. First, it explains the major feedback loops of the system to aid in understanding system behavior and policy analysis discussed in later chapters. Second, it describes the theoretical foundation of the model. Each section of the chapter contains a DYNAMO flow diagram of the structure being explained. A detailed explanation of the relationships and equations involved in each part of the structure will appear in Appendix A.

### 3.1 ALLOCATION OF PRODUCTION FACTORS BETWEEN SECTORS

Background: According to economic theory, an efficient allocation of production factors between production of different goods is achieved when the marginal utility of each factor in different production activities is equal. The marginal utility of a production factor in each sector is a measure of the satisfaction which is realized by using one more unit of the production factor in that sector.<sup>1</sup> It is shown that a competitive market approaches such an efficient allocation in equilibrium.<sup>2</sup> It is also argued that a centrally planned economy could move toward such an efficient allocation.<sup>3</sup> This theory of efficient allocation of factors is the foundation of the allocation mechanisms employed in the model. In the model, factors of production are shifted between sectors in order to equalize the marginal utility of production factors across sectors.

General Overview: Figure 3.1 shows the DYNAMO flow diagram of the feedback loops which govern the allocation of labor between the agricultural and industrial sectors in the model. Similar feedback loops underlie allocation of capital and education between the above sectors. The allocation mechanism shifts labor from one sector to another in order to equalize marginal utility of labor in both sectors. When marginal utility of labor in one sector is more than in the other, the demand for labor in the first sector increases. Gradually, labor moves to the sector with the higher marginal utility of labor. As a consequence, the output of that sector increases. As output of the sector becomes more

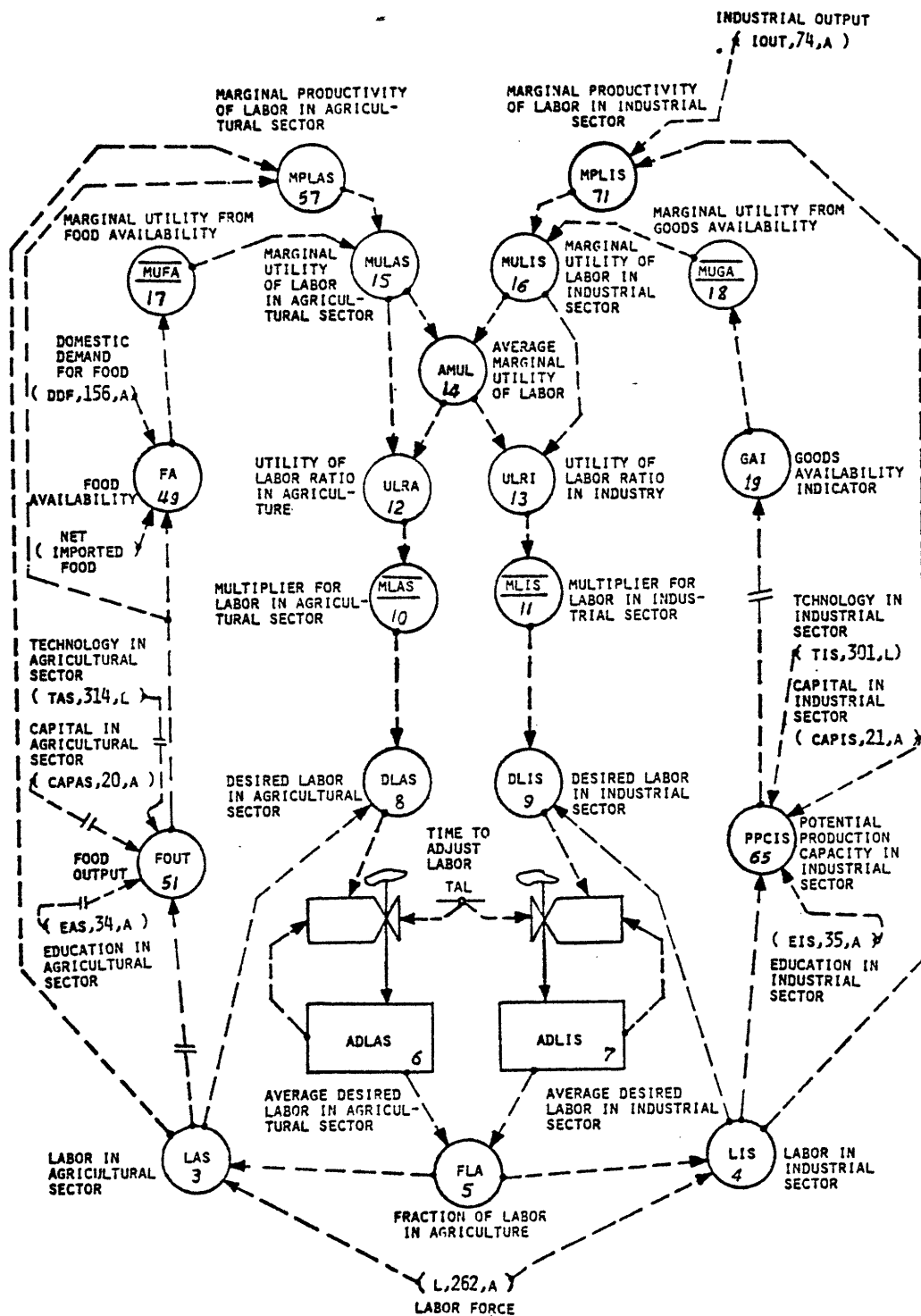

Figure 3.1: Allocation of Production Factors Between Different Sectors

available, the marginal utility of the sector's output drops. In addition to the rise of output, as labor moves to the sector, given that other production factors remain constant, the marginal productivity of labor in the sector also decreases. A lower marginal utility for the output and lower marginal productivity of labor in the sector decrease the marginal utility of the labor in the sector. The shift of labor continues until the marginal utility of labor in all sectors become equal.

Description of the Structure: As shown in Figure 3.1, labor in the agricultural sector LAS and labor in the industrial sectors are based on total labor L and the fraction of labor in agriculture FLA. For a given total labor L, when the fraction of labor in agriculture FLA rises, labor in agricultural sector LAS increases and labor in industrial sectors LIS decreases, and vice versa.

The fraction of labor in the agricultural sector FLA is based on the average desired labor in the agricultural sector ADLAS and the average desired labor in the industrial sectors ADLIS. When the average desired labor in the agricultural sector ADLAS relative to the average desired labor in the industrial sectors rises, the fraction of labor in the agricultural sector increases and labor moves to agriculture.

The average desired labor in each sector is a smoothed value of desired labor in that sector. When desired labor in one sector changes, average desired labor in that sector follows the same change, causing the shift of labor from one sector to another in response to the change of

desired labor. However, the response is not immediate in the model, in reflection of the delays inherent in the real world process of shifting production factors. For example, it takes time for rural people to perceive a higher possible standard of living in cities, and to make the decision to move from their villages to the unfamiliar environment of a city. It also takes time to develop urban facilities to accommodate new immigrants from rural areas.

The desired labor in each sector indicates a social goal for the amount of labor in that sector. The goal is set in a way that it moves the economic system towards an efficient allocation of labor between the agricultural and industrial sectors. The desired labor in the agricultural sector  $DLAS$  is computed as the product of labor in agricultural sector  $LAS$  and the multiplier for labor in agricultural sector  $MLAS$ . In the same way, the desired labor in industrial sector  $DLIS$  is set as the product of labor in industrial sector  $LIS$  and the multiplier for labor in industrial sectors  $MLIS$ .

Multiplier for labor in each sector modifies the amount of labor in order to set the desired labor for that sector. When labor becomes more efficient to increase the utility of the society as a whole in one sector than in the other, the multiplier for labor in the first sector becomes more than one, making desired labor in that sector more than actual labor. In the opposite direction, when labor is less efficient in one sector than in the other, the multiplier for labor in that sector

will be less than one and desired labor becomes less than the actual labor. Multiplier for labor in each sector is a function of the utility of labor ratio in that sector - multiplier for labor in agricultural sector MLAS is a function of the utility ratio of labor in the agricultural sector URLA, and the multiplier for labor in the industrial sector MLIS is a function of utility ratio of labor in the industrial sector URLI. As the utility ratio for labor in a sector increases, so does multiplier for labor in that sector.

The utility of labor ratio in each sector is a measure of the ability of labor in that sector to increase the total utility of the society relative to the average ability of labor to do so. A utility of labor ratio greater than one in each sector indicates that one more unit of labor in that sector can produce more satisfaction for the society than one more unit of labor in the other sector. The utility of labor ratio in each sector is the ratio of the marginal utility of labor in that sector to the average marginal utility - e.g., the utility of labor ratio in agriculture ULRA is the ratio of marginal utility of labor in agricultural sector MULAS and average marginal utility of labor AMUL. As the marginal utility of labor in a sector increases relative to the average marginal utility of labor, so does the utility of labor ratio in that sector.

Average marginal utility of labor AMUL is the average of marginal utility of labor in agricultural and industrial sectors, MULAS and MULIS, respectively. Marginal utility of labor in agricultural



sector MULAS is the utility or satisfaction which the nation derives from one more unit of labor in the agricultural sector. In the same way, marginal utility of labor in industrial sectors MULIS is the utility or satisfaction that the nation derives from one more unit of labor in the industrial sectors. Marginal utility of labor in each sector is the product of marginal utility from availability of the output of that sector and marginal productivity of labor in that sector - e.g., marginal utility of labor in agricultural sector MULAS is based on marginal utility from food availability MUFA and marginal productivity of labor in agricultural sector MPLAS.

Marginal utility from food availability MUFA represents the amount of satisfaction that the nation derives from one more unit of food. In the same way, marginal utility from goods availability MUGA is the amount of satisfaction that the nation derives from one more unit of industrial output. Marginal utility from availability of output of each sector is a function of availability of that output. For example, when food availability FA is quite low, a marginal increase in food availability produces much more satisfaction than when food is abundant. In the same way, the marginal utility from goods availability MUGA depends on an index of goods availability, goods availability indicator GAI.

The output availability of each sector is the ratio of real supply to the real demand for that output. For food, food availability is the ratio of total supply (domestic food output plus net imports) to

total demand of food when both supply and demand are measured in real terms. When food output FOUT plus net imported food is less than domestic demand for food DDF, food availability is less than one. When food output increases, so does food availability. For goods, goods availability indicator GAI is a weighted average of the availability of different industrial goods not shown in Figure 3.1. However, the availability of different industrial outputs is influenced by potential production capacity in the industrial sector PPCIS. As PPCIS increases, the output and availability of industrial goods (not shown on the figure) could rise, and finally the goods availability indicator GAI increases.

The output of each sector depends upon the production factors and the level of technology in that sector. In agriculture, food output FOUT depends indirectly on labor, capital, education, and technology in the agricultural sector - LAS, CAS, EAS, and TAS respectively - as well as land and energy availability not shown in Figure 3.1. In industry, potential production capacity in the industrial sector PPCIS depends on labor, capital, education, and technology in the industrial sector - LIS, CIS, EIS, and TIS, respectively. As labor, or any other production factor in a sector, increases, so does the output of that sector. A more detailed explanation of the relationship between output and production factors in each sector will appear in the following sections of this chapter.

As explained before, the marginal productivity of labor in each sector, in addition to the marginal utility from output availability, is

another determinant of the marginal utility of labor in that sector. The marginal productivity of labor in each sector is a function of the sector's output, as well as labor in that sector. The marginal productivity of labor in the agricultural sector  $MPLAS$  is a function of food output  $FOUT$  and labor in the agricultural sector  $LAS$ . In a similar way, the marginal productivity of labor in the industrial sector  $MPLIS$  is a function of industrial output  $IOUT$  and labor in the industrial sector  $LIS$ . The exact relationship between labor and its marginal productivity in each sector will be explained in Appendix A. However, the relationship is consistent with the well-accepted economic law of diminishing marginal productivity. In accordance with that law, when labor in a sector rises, given that the other production factors in the sector remain constant, the marginal productivity of labor drops.

The mechanism explained above, depicted in figure 3.1, governs the allocation of production factors between major sectors in the model. When a shortage of output in one sector appears, the sector's marginal utility of output increases, the marginal utility of production factors in the sector rises, and as a result the mechanism shifts production factors to that sector (The process works in reverse for an abundance of output). The mechanism also balances production factors between different sectors based on their marginal productivity in the sectors. If the intensity of one factor in a sector is high, marginal productivity of the factor in that sector will be low. Low marginal productivity of

the factor leads to low marginal utility of the factor in that sector. Because of the low marginal utility of the factor in the sector, the mechanism tends to shift the factor to the other sector.

### 3.2 AGRICULTURAL SECTOR

Background: The agricultural sector produces food. The amount of production factors allocated to the sector, in combination with the level of technology in the sector, determine the potential food output. As agricultural development takes place, potential food output per agricultural laborer increases. A higher potential output per laborer in agriculture requires a higher consumption of energy per worker in food production. The potential food output can materialize only if the required energy is provided. If an energy shortage appears, the real food output will drop. Presently, and probably through the next two or three decades, development of the economy, in general, and agriculture, in particular, will require oil as the major source of energy. Therefore, a future oil shortage implies an overall energy shortage and a drop in food output. This section explains the formulation of food production in the agricultural sector, including the influence of oil availability on food output.

General Overview: Figure 3.2 shows the DYNAMO flow diagram of the agricultural sector. In the part of the model shown in Figure 3.2, food availability FA, total food TF, and the marginal productivity of different factors in the agricultural sector are in part determined by

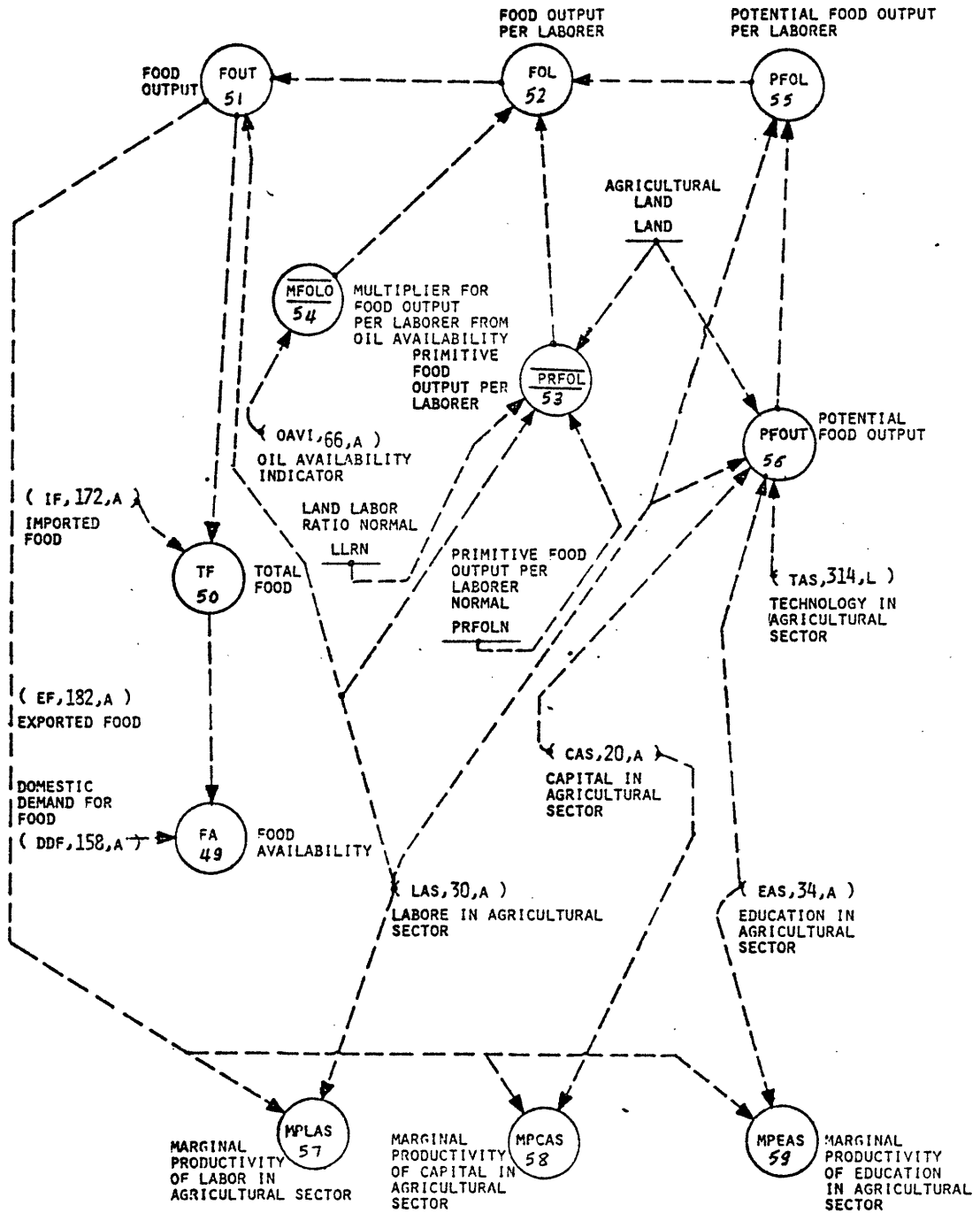

Figure 3.2: DYNAMO Flow Diagram of Food Output Formulation

food output FOUT. FOUT depends basically on potential food output as well as oil availability as the major energy source. Potential food output is based on production factors and the technology level in the agricultural sector.

Description of the Structure: Food availability FA, shown in Figure 3.2, is the ratio of total food TF and domestic demand for food DDF, both measured in real terms. When domestic demand for food DDF is more than total food (supply) TF, FA is less than one. As TF increases, so does food availability FA.

Total food TF, representing total food supply in the country, is food output FOUT plus imported food minus exported food, all measured in real terms at 1972 prices.

Food output FOUT equals food output per laborer FOL multiplied by the labor in agricultural sector LAS. As food output per laborer FOL increases, indicating a rise in the productivity of labor in the sector, food output thus also rises.

Food output per laborer FOL is an adjusted value of the potential food output per laborer PFOL. The adjustment is based on the value of multiplier for food output per laborer from oil availability MFOLO. When the value of MFOLO is one, indicating that the desired energy for the operation of the economy is available, food output per laborer FOL will be the same as potential food output per laborer PFOL. When the value of MFOLE is less than one, indicating the existence of an

oil shortage, FOL will drop below PFOL towards the primitive food output per laborer PRFOL.

The primitive food output per laborer PRFOL represents the food output per laborer which could be achieved by a primitive society using the same amount of land and labor being used by the agricultural sector. PRFOL depends primarily on the labor in agricultural sector LAS and the amount of agricultural land in the country LAND (assumed to be constant). As labor in the agricultural sector LAS increases, available land per laborer drops and primitive food output per laborer decreases.

Multiplier for food output per laborer from oil availability MFOLO represents the effect of oil availability on food output per laborer FOL. MFOLO depends on the oil availability indicator OAVI. As OAVI decreases below one, indicating an oil shortage, MFOLO becomes less than one to decrease food output per laborer FOL below potential food output per laborer PFOL. The intensity of the effect of an oil shortage on agricultural output depends on the advancement of the sector.

The more advanced the agricultural sector is, the more it depends on oil as the source of energy, and the more it will be affected by an oil shortage. In a modern agriculture, a laborer using capital equipment and knowledge produces more output than his counterpart in a primitive agriculture. In a primitive agriculture, the major source of energy in production activities is human and animal. Presently, societies with per capita incomes of approximately \$100 per year can be considered very close to the level of primitive. The bulk of the

difference between output per laborer in advanced and primitive agriculture stems from the use of machines in the former. The usage of machinery requires energy. Lack of energy idles machines and equipment used in production processes, and, as a result, the productivity gap between modern and primitive societies decreases when energy is inadequate. When oil is the major source of energy, low availability of oil results in a shortage of energy and decreases potential food output per laborer towards the primitive food output per laborer.

Potential food output per laborer PFOL represents the food output per laborer which can be achieved when there is no oil shortage. PFOL is equal to potential food output PFOUT divided by labor in the agricultural sector LAS.

Potential food output PFOUT represents the agricultural output if the required energy in the production activities is provided. PFOUT is based on technology in the agricultural sector TAS and the four production factors in the sector. The production factors in the agricultural sectors are: labor in agricultural sector LAS, capital in agricultural sector CAS, education in agricultural sector EAS, and LAND. The amount of land is exogenous to the model and is assumed to be constant.

In this part of the model shown in Figure 3.2, marginal productivity of labor, capital, and education in agricultural sector MPLAS, MPCAS, and MPEAS respectively, are also determined. The marginal productivity of each factor is based on food output FOUT and the amount



of that factor in the sector. The formulation of the marginal productivity of each factor is such that when a factor in the agricultural sector increases, its marginal productivity drops, given that the other factors remain constant. Appendix A explains the exact relationship between marginal productivity of different factors in the agricultural sector and food output.

### 3.3 PRODUCTION CAPACITY IN THE INDUSTRIAL SECTORS

Background: The production factors allocated to the industrial sectors and the level of technology determine the total potential production capacity in the non-agricultural sectors. This potential production capacity represents the total potential production capability of the nation outside of the agricultural sector. As economic development occurs, potential output per capita increases. A higher potential output per capita requires a higher consumption of energy per person. The potential industrial output materializes only if the required energy is provided. If an energy shortage appears, the real industrial output will be less than potential. Presently, and probably through the next two or three decades, oil will be the major energy source. Therefore, a future oil shortage implies an overall energy shortage and a drop in industrial output. This section explains the formulation of production capacity in the industrial sector, including the influences of oil availability on the industrial production capacity.

General Overview: Figure 3.3 shows the DYNAMO flow diagram of the formulation of production capacity in the industrial sectors of the model. This part of the structure determines production capacity in industrial sectors, marginal productivity of each production factor in the sectors, as well as the oil availability indicator. Production capacity in industrial sectors depends basically on potential production capacity in industrial sectors and oil availability. Potential production capacity in the industrial sectors is based on production factors and technology level in the industrial sectors. Oil availability depends on oil reserves and domestic demand for energy. Demand for energy is basically a function of potential non-oil output.

Description of the Structure: Production capacity in the industrial sectors PCIS is computed as the labor in industrial sectors LIS times the production capacity per laborer in industrial sectors PCLI.

Production capacity per laborer in industrial sectors PCLI is an adjusted value of potential production capacity per laborer in industrial sectors PPCLI. The adjustment is based on the value of multiplier for production capacity per laborer in industry from oil availability MPCLIO. When the value of MPCLIO is one, indicating that the desired energy for the operation of the economy is available, production capacity per laborer in the industrial sectors PCLI is the same as PPCLI. When the value of MPCLIE is less than one, indicating the existence of an oil shortage, PCLI will drop below PPCLI towards the primitive production capacity per laborer in industrial sectors PRPCLI.

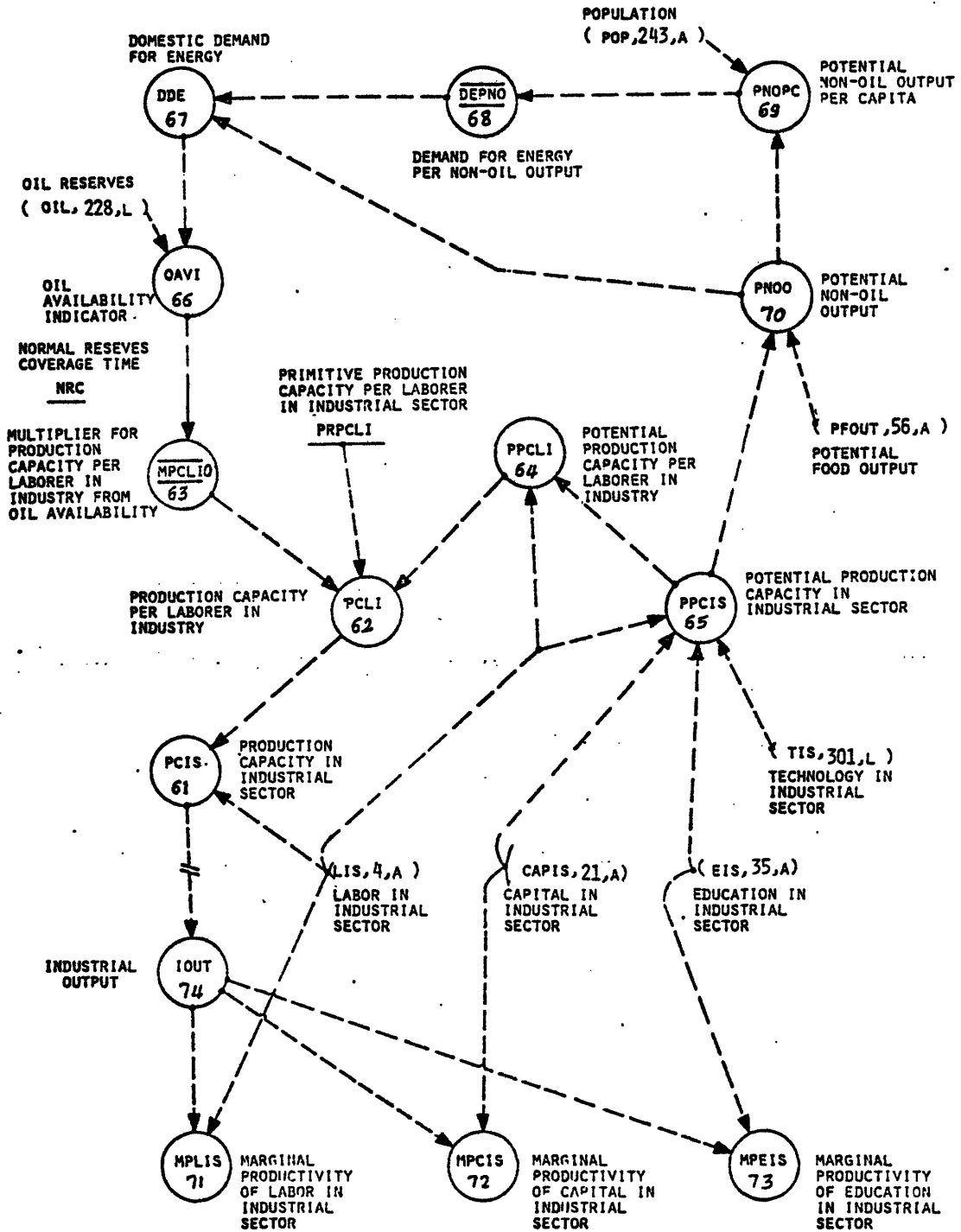

Figure 3.3: DYNAMO Flow Diagram of the Formulation of Production Capacity in the Industrial Sector.

The primitive production capacity per laborer in industrial sectors PRPCLI represents production capacity per laborer in the non-agricultural sectors of a primitive society mostly composed of simple craftsmen and small retailers. PRPCLI is assumed to be constant in the model.

Multiplier for production capacity per laborer in industry from oil availability MPCLIO represents the effect of oil availability on the production capacity per laborer in industrial sectors PCLI. MPCLIO depends on oil availability indicator OAVI. As OAVI decreases below one, indicating an oil shortage, MPCLIE becomes less than one to decrease PCLI below the potential production capacity per laborer in industrial sectors PPCLI. The intensity of the effect of an oil shortage on industrial production capacity depends on the technological advancement of the sector. The more advanced the industrial sector is, the higher its potential production capacity per laborer. The more the sector depends on energy, and the more it will be affected by an oil shortage.

Potential production capacity per laborer in industrial sectors PPCLI represents the production capacity per laborer in industrial sectors when there is no oil shortage. PPCLI is equal to the potential production capacity in industrial sectors PPCIS divided by labor in industrial sectors LIS.

Potential production capacity in the industrial sectors PPCIS represents the production capacity in the industrial sectors if the required energy in the production activities is provided. PPCIS depends

on technology in industrial sectors TIS, labor in industrial sectors LIS, capital in industrial sectors CAPIS, and education in industrial sectors EIS through an aggregate production function.

Oil availability indicator OAVI, which influences the production capacity of the industrial sectors, is based on the domestic demand for energy DDE, oil reserves OIL, and a required reserve coverage time for production RRCP. If oil reserves can cover domestic demand for energy over a period of time longer than required reserves coverage time for production RRCP, oil availability is considered high and OAVI will be more than 1. When reserves can cover the domestic demand for energy over a period of time less than RRCP, then oil availability indicator OAVI will be less than one, indicating a shortage of oil.

Domestic demand for energy DDE represents demand for energy in the country. DDE is equal to the potential non-oil output PNOO times demand for energy per non-oil output DEPNO. As economic development takes place, both potential non-oil output PNOO and the demand for energy per non-oil output DEPNO increases. As a result, domestic demand for energy DDE rises rapidly.

Demand for energy per non-oil output DEPNO is a function of potential non-oil output per capita PNOPC. As PNOPC increases, indicating economic progress and rise in output per laborer, so does the demand for energy per non-oil output. In an underdeveloped economy with a very low economic output per capita, production activities are carried out mostly using human and animal energy. As economic growth takes

place, the stock of capital equipment per laborer increases and production activities become more capital intensive, increasing output per capita in the economy. More intensive use of machinery to produce one unit of output requires a higher amount of energy per unit of output to operate the machinery. Also, as output per capita increases, new patterns of consumption develop. The consumption of durable goods such as automobiles, washing machines, and TV sets rises, the number of buildings with heating and air-conditioning facilities increases, and all of these elements in the new pattern of consumption raise the demand for energy.

Potential non-oil output per capita PNOPC is equal to potential non-oil output PNOO divided by population POP. As PNOO increases relative to the population, potential non-oil output per capita PNOPC rises.

Potential non-oil output PNOO is the summation of potential production capacity in industrial sectors PPCIS and potential food output PFOUT. PNOO represents the potential production capability of the nation excluding oil production. As the potential production capability in each of the two non-oil sectors--the industrial and agricultural sectors--increases, so does the potential non-oil output PNOO.

This part of the model, shown in Figure 3.3, also determines marginal productivity of labor, capital, and education in the industrial sectors MPLIS, MPCIS, and MPEIS respectively. The marginal productivity

of each factor is based on industrial output IOUT and the amount of that factor in the industrial sectors. The formulation of marginal productivity of each factor is such that when the amount of that factor, relative to the other factors in the industrial sector, rises, the marginal productivity of that factor drops.

#### 3.4 ALLOCATION OF PRODUCTION CAPACITY IN THE INDUSTRIAL SECTORS

Background: Nations, in both market and planned economies, shift their production capability from one sector to another in response to their unsatisfied desire for the output of different sectors. In a market economy, when supply can not satisfy demand, the price of the sector's output rises, profitability increases, and investors expand the production capacity of the sector. Conversely, when output is excessive, price declines, leading to the contraction of output. In a planned economy, demand relative to the supply of a sector's output is perceived through the availability of output, if not through prices. In such an economy, planners would eventually respond to shortages or abundance by increasing or decreasing the production capacity of the sector. In a semi-planned economy such as Iran, both market mechanisms and planning agencies are at work to allocate the production capacity of the nation according to the above principle. This principle is the foundation of the mechanism which allocates industrial production capacity (explained in the previous section) among consumer goods, capital goods, intermediate goods, and education sectors.

General Overview. Figure 3.4 shows the major feedback loops in the consumption goods sector. These feedback loops, together with the analogous loops in the capital and intermediate goods sectors, govern the allocation of production capacity between different sectors. The feedback mechanism shown in Figure 3.4 brings the total supply of the output of the sector into balance with the total demand for that output. For example, if demand for consumption goods becomes greater than total supply, availability of consumption goods drops. The desire to expand the sector increases and eventually production capacity in the consumption-goods sector rises. The rise in production capacity causes the output of the sector to increase, and as a result, total supply increases to meet the demand. The expansion of the sector depends on the utilization of the production capacity of the sector as well as the productivity of the sector: A low utilization of the production capacity, which could be a result of an intermediate goods shortage, discourages expansion of the sector. A low productivity also slows down the growth of the sector. The productivity of the sector is based on average production in the sector, indicating its level of experience in the production activities, and the potential production capacity of the sector.

Description of the Structure: As shown in Figure 3.4, the output of the consumption-goods sector OUTCON represents the output of final goods and services except that of capital-goods and education. OUTCON consists of the value added in the economic activities in the



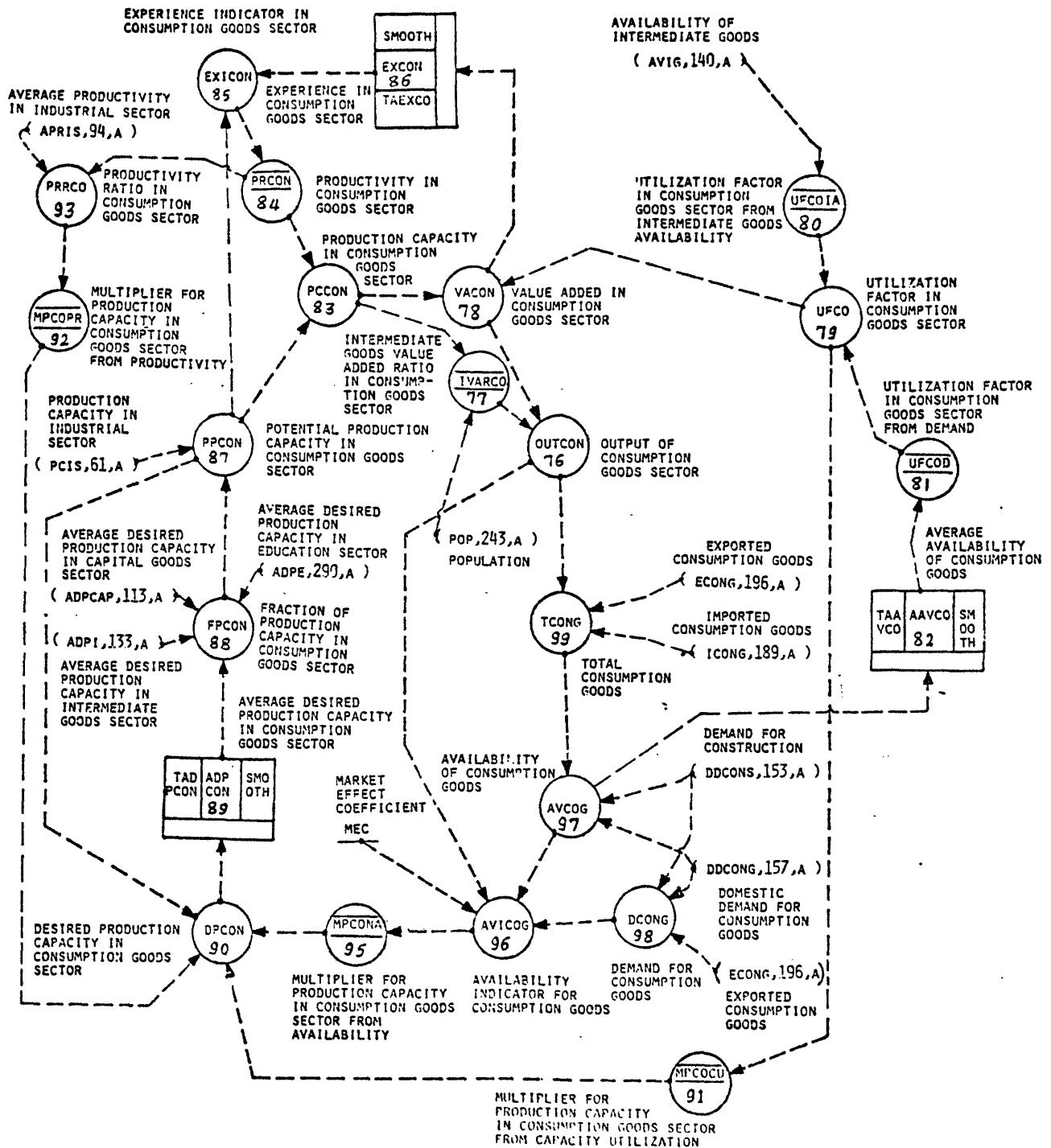

Figure 3.4: Consumption Goods Sector

consumption-goods, construction, services, transportation and communication industries, as well as the value of intermediate goods used in these activities. In the model, OUTCON is based on value added in the consumption-goods sector VACON and the intermediate-goods value-added ratio in consumption-goods sector IVARCO. As VACON increases, so does OUTCON. Also, a rise in IVARCO causes the output of the consumption-goods sector OUTCON to increase.

Intermediate-goods value-added ratio in consumption goods sector IVARCO represents the ratio of total intermediate goods used by the consumption-goods sector to the value added in that sector. As the economy develops, IVARCO changes. The intermediate-goods value-added ratio in manufacturing is much higher than in services. As development takes place, the share of manufacturing relative to services in the consumption-goods sector increases. As a result, on the average, the intermediate-goods value-added ratio in the sector increases. In the model, IVARCO depends on the production capacity in consumption-goods sector PCCON and population POP. When PCCON relative to population POP increases, indicating progress in the development of the economy, IVARCO also rises.

Value added in the consumption goods sector VACON represents value added in all economic activities included in the consumption-goods sector. VACON is the product of the production capacity in consumption-goods sector PCCON and utilization factor in consumption-goods sector UFCO. When the utilization factor in the

consumption-goods sector UFCO is less than one, VACON drops relative to PCCON.

Utilization factor in consumption-goods sector UFCO represents the fraction of production capacity of the sector which is utilized. Utilization fraction may decrease because of insufficient demand for output as well as insufficient intermediate goods to be used by the sector. UFCO is the product of utilization factor in consumption-goods sector from intermediate-goods availability UFCOIA and utilization factor in consumption-goods sector from demand UFCOD.

The utilization factor in consumption-goods sector from intermediate-goods availability UFCOIA represents the utilized fraction of the production capacity in the consumption-goods sector based on intermediate-goods availability. UFCOIA is a function of availability of intermediate goods AVIG. When the availability of intermediate goods AVIG is less than one, it indicates that the required intermediate goods for the operation of the economy are not fully available. As a result of the low availability of intermediate goods, such as parts and raw material in manufacturing, the production capacity cannot be fully utilized. UFCOIA drops below one, indicating the existence of some idle production capacity in the sector.

The utilization factor in consumption goods sector from demand UFCOD represents the utilized fraction of production capacity in the sector based on demand. UFCOD is a function of average availability of consumption goods AAVCO. When average availability of consumption goods

AAVCO is greater than one, demand for consumption goods output has been less than supply in the previous year. As a result of low demand, production capacity in the sector will not be fully utilized. UFCOP drops below one, indicating underutilization in production capacity.

Average availability of consumption goods AAVCO is an information about recent values of consumption goods availability in the market. AAVCO is used by producers to determine level of output. AAVCO is a smooth function of availability of consumption goods AVCOG. As AVCOG increases, so does average availability of consumption goods AAVCO after some delay. The delay represents the necessary time for the producers to perceive the condition of demand relative to supply in the market.

Production capacity in the consumption-goods sector PCCON is the production capability in the sector given that its necessary intermediate goods are available. PCCON is equal to the potential production capacity in the consumption-goods sector PPCON times productivity in consumption-goods sector PRCON. As PPCON increases, so does the production capacity in the consumption-goods sector PCCON. PCCON approaches to the potential production capacity in consumption-goods sector PPCON as the sector accumulates experience in production activities and increases its productivity to explore all of its potential production capability.

Productivity in the consumption goods sector PRCON is a function of the experience indicator in the consumption-goods sector EXICON.

Since the 1930's, a number of empirical works, such as R.P. Wright (1936) and Hirsch (1950), have shown that when experience in a production activity increases, productivity rises, but at a diminishing rate. If a sector expands too rapidly, such that the fraction of inexperienced people involved in the production activities rises, the resulting lowered average level of experience will cause productivity in that sector to drop.

The experience indicator in consumption-goods sector EXICON is set as the ratio of experience in consumption-goods sector EXCON to potential production capacity in the consumption-goods sector PPCON. When a larger fraction of workers becomes experienced in the production activities of the sector, EXCON relative to the potential production capacity in consumption-goods sector PPCON increases. As a result, the experience indicator in consumption goods sector EXICON increases to indicate a higher average level of experience in the sector.

Experience in the consumption-goods sector EXCON indicates the level of production activity at which the sector can operate efficiently, based on its accumulated experience. EXCON is a smoothed value of value added in the consumption-goods sector VACON.

Potential production capacity in the consumption-goods sector PPCON is the production capacity that the sector can achieve if all its employees have adequate experience in their jobs. PPCON is the fraction of production capacity in the consumption-goods sector FPCON times the production capacity in industrial sector PCIS (explained in the previous

section). As FPCON increases, indicating a shift of production resources to the consumption-goods sector, so does PPCON.

The fraction of production capacity in the consumption-goods sector FPCON indicates the fraction of non-agricultural production capability of the nation which is allocated to the consumption-goods sector. FPCON is based on the average desired production capacity in the consumption-goods sector ADPCON, the average desired production capacity in the capital-goods sector ADPCAP, the average desired production capacity in the intermediate-goods sector ADPI, and the average desired production capacity in the education sector ADPCE. As ADPCON increases, relative to the average desired production capacity in the other sectors, so does FPCON.

Average desired production capacity in consumption-goods sector ADPCON is a smoothed value of desired production capacity in consumption-goods sector DPCON. As DPCON increases, so does ADPCON, in order to shift more production capacity to the consumption-goods sector. However, the response of ADPCON to the changes of desired production capacity in the consumption-goods sector DPCON is not immediate. The desire to expand the sector must be perceived by the government and/or entrepreneurs. Plans have to be prepared, resources must be channeled away from other activities and be organized around new activities, pioneers must first show success before others will begin to follow. All of these activities take time. The smooth function which determines

ADPCON is simulates the necessary time involved in shifting production resources from one sector to another.

The desired production capacity in the consumption-goods sector DPCON indicates what the nation desires to have in the sector. DPCON is an adjusted value of potential production capacity in the consumption-goods sector PPCON. DPCON is the product of PPCON and three multipliers: the multiplier for production capacity in the consumption-goods sector from capacity utilization MPCOCU, the multiplier for production capacity in the consumption-goods sector from productivity MPCOPR, and the multiplier for production capacity in the consumption-goods sector from availability MPCONA. Each of these multipliers indicates a pressure for expansion or contraction of the sector. If the net result of the pressures is to expand the sector, DPCON becomes more than PPCON, and vice versa.

The multiplier for production capacity in consumption-goods sector from capacity utilization MPCOCU represents the effect of capacity utilization in the sector on its expansion. MPCOCU is a function of the utilization factor in the consumption-goods sector UFCO. When a shortage of intermediate goods exists, and/or demand is lower than production capacity, UFCO becomes less than one and capacity utilization in the consumption-goods sector drops. Profitability in the sector decreases and some producers might go bankrupt. Private investors may become reluctant to invest in the sector. In addition, the government, through

licensing and other policy instruments, might discourage the expansion of the sector to prevent the wasteful allocation of production resources to a sector which cannot utilize them completely. Thus, in the model, when the utilization factor in the consumption-goods sector UFCO becomes less than one, the multiplier for production capacity in the consumption-goods sector from capacity utilization MPCOCU decreases to represent the combined effect of the previously described influences. A fall in MPCOCU causes the desired production capacity in consumption-goods sector DPCON to decline.

The multiplier for production capacity in the consumption-goods sector from productivity MPCOPR represents the effect of the productivity of the sector on its expansion. MPCOPR is a function of the productivity ratio in the consumption-goods sector PRRCO. When the productivity in the consumption goods, relative to the other sectors, decreases, PRRCO falls. Production resources become less productive in the consumption-goods sector relative to the other sector. By shifting its production resources to the other sectors, the nation can utilize them more effectively. Therefore, as PRRCO drops, MPCOPR decreases in order to reduce the desired production capacity in the consumption-goods sector DPCON.

The productivity ratio in the consumption-goods sector PRRCO indicates the productivity of the production resources in the consumption-goods sector relative to the average productivity of



productive resources in the nation. PRRCO is the ratio of productivity in consumption-goods sector PRCON to the average productivity in industrial sectors APRIS. When PRCON relative to APRIS increases, so does PRRCO.

Another determinant of the desired production capacity in the consumption-goods sector DPCON is the multiplier for production capacity in the consumption-goods sector from availability MPCONA. MPCONA is function of the availability indicator for consumption goods AVICONG. When the availability of consumption goods is low, i.e., real demand exceeds real supply, both market mechanism and planning agencies work to expand the sector and increase the supply of its output. Therefore, when AVICONG is low, MPCONA will be greater than one to increase the desired production capacity in the consumption-goods sector DPCON above the potential production capacity in the sector PPCON, indicating desire to expand the sector. In the opposite direction, when the availability indicator of consumption goods is high (supply exceeds demand), MPCONA will be less than one, showing desire to contract the sector.

The availability indicator for consumption goods AVICOG represents a combination of the availability of consumption goods in the market and imports substitution possibilities in the consumption-goods sector. The availability of consumption goods in the market, a measure of real demand relative to the real supply, is an influential factor in changing the production capacity of the sector. However, in a

semi-planned economy, it is not the only indication of availability. While the demand for a sector's output may equal the total supply, domestic output relative to demand might be quite low and therefore imported goods will constitute a substantial part of the total supply. A low share of domestic output in the total supply signals: (1) the possibility of import substitution in the sector, and (2) the risk of a dependence on foreign suppliers. Both signals can cause the government and the private sector of the economy to initiate actions to expand the sector. Therefore, in the model, the availability indicator of consumption goods AVICOG, which is a determinant of the expansion or contraction of the sector, is a weighted average of the availability of consumption goods (in the market) AVCOG and the ratio of output of consumption goods OUTCON to the demand for consumption goods DCONG. The weighting factor is the market effect coefficient MEC. MEC is a policy variable. The higher the value of MEC, the more the market mechanism--rather than imports substitution possibilities--influences the expansion of the sector, and vice versa.

The demand for consumption goods DCONG represents total domestic and foreign demand for the output of the sector. DCONG is the summation of domestic demand for consumption goods DDCONG, demand for construction DCONS, and foreign demand for consumption goods. Foreign demand is approximated by calculating the exported consumption goods ECONG.

The availability of consumption goods AVCOG is a measure of the

real demand to the real supply of the sector. AVCOG depends on total consumption goods TCONG, domestic demand for consumption goods DDCONG, and demand for construction DCONG. If the sum of DCONS and DDCONG exceeds total consumption goods TCONG, the availability of consumption goods (in the market) AVCOG is low, and vice versa.

Total consumption goods TCONG represents the total sector's output available in the nation. TCONG consists of consumer goods, construction, and services (except education) produced in the nation, and net imports of these products. TCONG is the output of consumption goods OUTCON plus imported consumption goods ICONG minus exported consumption goods ECONG.

### 3.5 ALLOCATION OF INCOME AND CAPITAL ACCUMULATION

Background: The ultimate goal of economic activities is to produce and supply goods and services for consumption. The major concern of economic growth is to expand the production capacity of the country in order to increase the supply of consumer goods and services over time. To expand the production capacity of the economy, the country increases the factors which contribute to economic output.

One of the factors determining output is capital stock, which consists of buildings and equipment. In almost all economic growth theories, capital stock is one of the determinants of output<sup>4</sup>. Other important determinants of growth discussed later are labor, education level (which is also called human capital), and technology. Capital

stock is increased through investment and decreased via depreciation. The nation increases its capital stock by allocating some of its income to investment. The remaining portion is devoted to consumption of food and other goods and services. This section explains income allocation and capital stock accumulation in the model.

General Overview. Figure 3.5 shows the DYNAMO flow diagram of the capital accumulation and income allocation structure. Gross national product and accumulated income, in the form of foreign exchange, determine the available income to be spent. Available income generates demand for food, consumption goods, services, and capital investment. Demand for capital investment results in investment in construction and equipment. Capital formation, resulting from investment in construction and capital equipment, increases the capital stock. A rise in capital stock leads to a rise in non-oil output, which provides a higher GNP to be allocated between competing demand.

Description of the Structure: Capital stock CAP, shown in Figure 3.5, represents the stock of construction and machinery in the nation. CAP is increased by capital formation CAPF and decreased by capital depreciation CAPD.

Capital depreciation CAPD is the rate at which the capital stock wears out. CAPD is capital stock CAP divided by the life of capital LCAP.

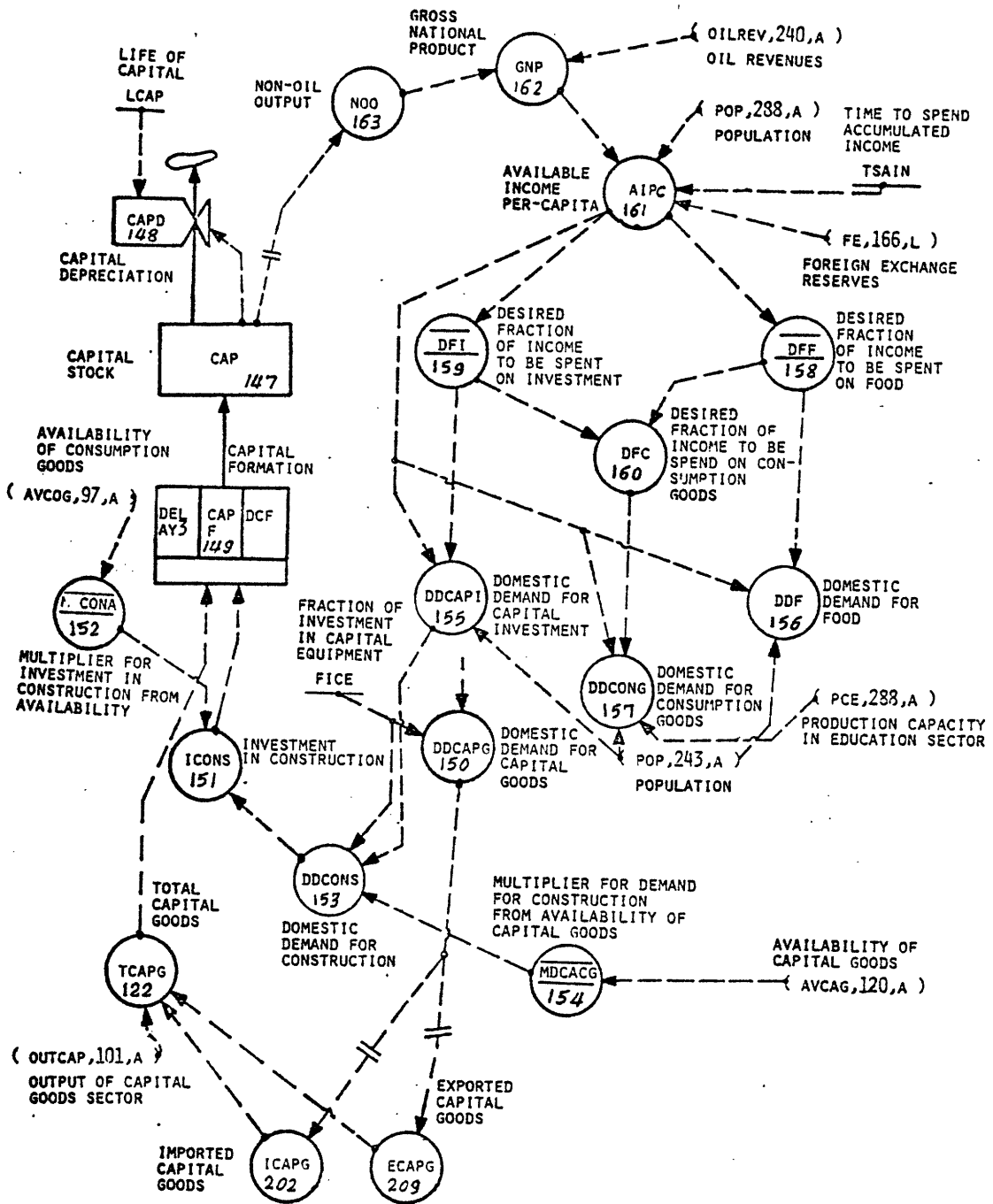

Figure 3.5: Allocation of Income and Accumulation of Capital

Capital formation CAPF is a rate at which new capital is added to the capital stock. CAPF is a delayed value of the sum of investment in construction ICONS and total capital goods TCAPG. The delay represents the average period between the time that investment for a new plant takes place and the time that the plant becomes ready to be used in production activities.

Total capital goods TCAPG is the amount of investment in capital equipment in each year. TCAPG is the output of capital goods OUTCAP plus imported capital goods ICAPG minus exported capital goods ECAPG.

As will be explained in the trade sector, imported and exported capital goods depend basically, among other factors, on domestic demand for capital goods DDCAPG.

Domestic demand for capital goods DDCAPG is demand for machinery and equipment in the economy. DDCAPG is a fraction of domestic demand for capital investment DDCAPI, which represents demand for total investment. The remaining fraction of DDCAPI is demand for construction DCONS.

Investment in construction ICONS, the other determinant of capital formation, is equal to demand for construction DCONS times the multiplier for investment in construction from availability MICONA. When MICONA is low (less than one) demand for construction DCONS cannot be totally satisfied and investment in construction ICONS will be less than DCONS.

The multiplier for investment in construction from availability MICONA represents the effect of the availability of the output of the consumption goods sector on the investment in construction. MPCONA is a function of availability of consumption goods AVCOG. In the model, the construction industry is included in the consumption-goods sector. Thus, when the availability of the output of the consumption-goods sector is low, the same is assumed for the availability of construction output. When the availability of consumption goods AVCOG is low (less than one), the multiplier for investment in construction from availability will be low (less than one) too. As a result, ICONS falls below demand for construction DCONS.

Domestic demand for capital investment DDCAPI indicates the demand for total investment in both machinery and buildings. DDCAPI is equal to the desired fraction of income to be spent on investment DFI times available income per capita AIP times population POP.

Similar in formation to DDCAPI, domestic demand for food DDF and domestic demand for consumption goods DDCONG are based on available income per capital AIP, population POP, and desired fraction of income to be spent on food DFF and desired fraction of income to be spent on consumption goods DFC, respectively.

The desired fraction of income to be spent on food DFF, the desired fraction of income to be spent on investment DFI, and the desired fraction of income to be spent on consumption goods DFC represent the

pattern of income allocation in the nation among food, investment, consumer goods and services. The allocation pattern depends on available income per capita AIPC. As income per capita increases, the fraction of income to be spent on food decreases. The fraction invested and the fraction spent on consumer goods and services rises.<sup>5</sup> In the model, DFI and DFF are based on the available income per capita AIPC. DFC is one minus DFI and DFF. Therefore, the three fractions, DFF, DFI, and DFC, add up to one.

The available income per capita AIPC is based on GNP, foreign exchange reserves FE, and population POP. If Iran were not involved in any foreign trade, it would be legitimate in a long-run growth study, like this, to assume that total GNP in each year is either consumed or invested. Such an assumption ignores the changes of inventories of goods and implies that the nation as a whole does not accumulate any part of its income to be consumed or invested in later periods. However, since Iran trades with other nations, foreign exchange reserves can become substantial portion of the accumulated income of the nation in the form of claims on goods and services produced in other parts of the world. Exporters, who could be from the private sector or the government, consider their accumulated foreign exchange earnings as unspent income to be either consumed or invested in the future. A large accumulation of income in the form of foreign exchange reserves occurs when exports rise rapidly but trade policies restrict the growth of imports. For example, in Iran after the 1973 jump in oil prices, oil revenues rose by a factor



of 5, resulting in a large accumulation of foreign exchange reserves. These accumulated reserves constituted a source for demand and spending over and above GNP. Foreign exchange reserves FE divided by time to spend accumulated income TSAIN gives an equivalent income in addition to GNP, which should be allocated between investment and consumption. Such equivalent income, plus GNP divided by population, sets available income per capita AIPC.

Gross national product GNP is equal to non-oil output NOO plus oil revenues OILREV. The non-oil output NOO is the total output of the agricultural and industrial sectors. NOO depends basically, but indirectly, on the production factors, such as capital stock, shown in Figure 3-5.

### 3.6 FOREIGN TRADE: IMPORT AND EXPORT MECHANISMS

Background: Foreign trade allows a nation to demand and consume more or less of a certain good than it produces domestically. If domestic demand is higher than domestic production, the country might want to import the difference when foreign exchange is readily available. When domestic supply exceeds demand, the excess domestic supply can be exported to obtain foreign exchange. The government can control the importation and exportation of different goods through its foreign trade policies. Foreign trade policy instruments include tariff, quotas, licensing, etc. Foreign trade policies also influence domestic economic activities. For example, governmental restriction of

consumption-good imports protects domestic producers in the consumption goods sector and encourages further expansion of that sector.

This section discusses the mechanisms that govern the trading of food, consumption, capital, and intermediate goods.

General Overview. Figure 3.6 depicts the trade mechanisms for food. The formulation of the trade of other goods is analogous to that shown for food. The trade mechanisms bring into balance demand and supply of different goods in the country through foreign trade, subject to the governmental policies, and within possibilities determined by available foreign exchange.

As shown at the top of Figure 3.6, the difference between domestic demand for food DDF and food output FOOT is demand output discrepancy for food DODF. This discrepancy between domestic demand and output determines the desired import and desired export of food, subject to government's policies and regulations. The desired import of food DIF and foreign exchange availability determine imported food IF. Imported food IF increases the total imports TI that depletes the foreign exchange reserves FE. Exported food EF is an adjusted value of average export of food AEF. The adjustment is based on the value of desired export of food DEF relative to average export of food. When desired export exceeds average export, exported food EF increases above average export, and vice versa. EF increases the total exports whose value is an in-flow to the foreign exchange reserves FE.

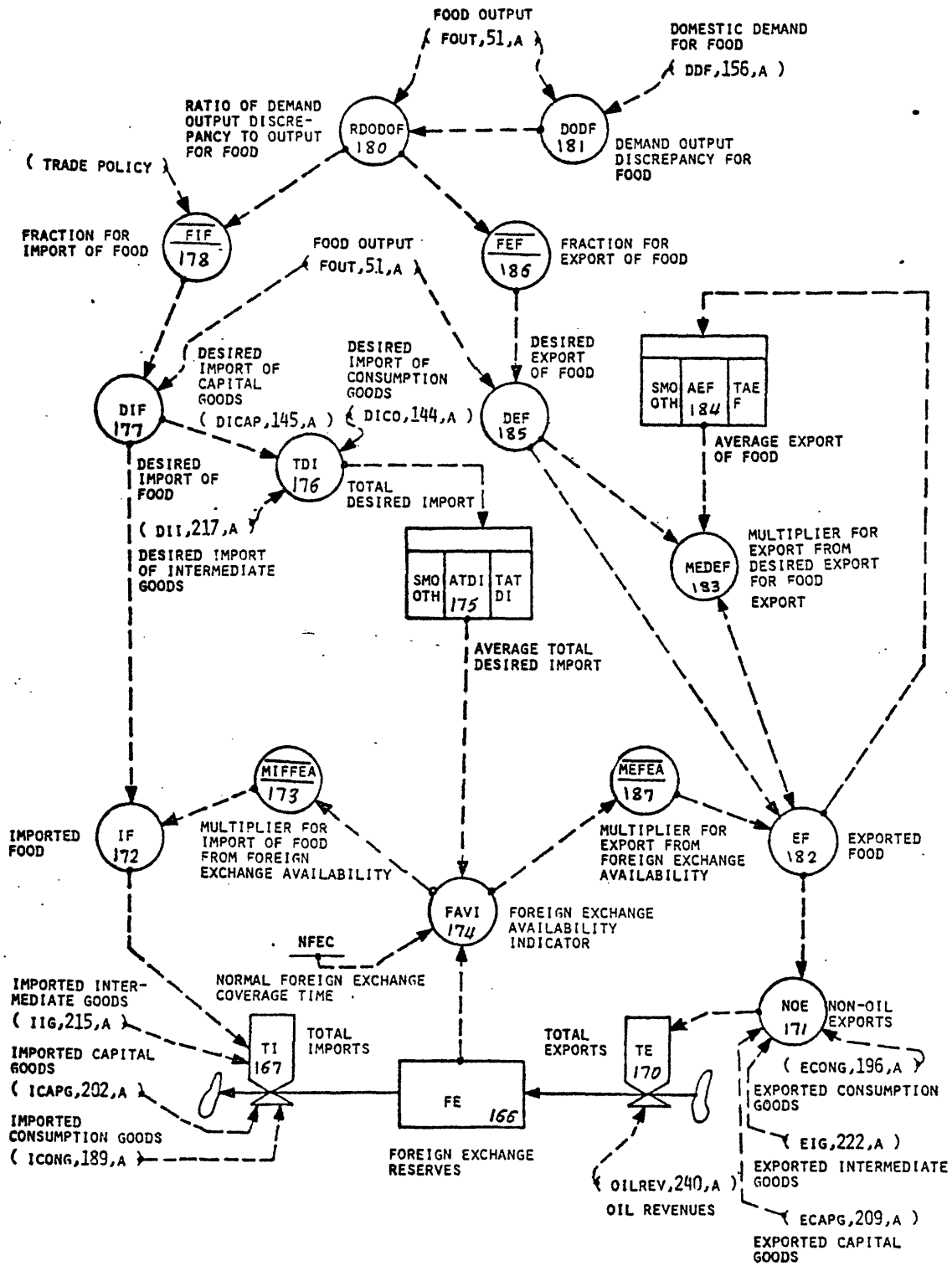

Figure 3.6: Imports and Exports of Food

Description of the Structure: Foreign exchange reserves FE are increased by the value of total exports TE and decreased by the value of total imports TI.

Total imports TI is the sum of imported food IF, imported intermediate goods IIG, imported capital goods ICAPG, and imported consumption goods ICONG. Similarly, total exports TE consists of exports from the same four sectors plus oil revenues OILREV. Imports and exports of goods from different sectors are determined by structures similar to that shown in Figure 3.6.

Imported food IF depends on desired import of food DIF and on the multiplier for import of food from foreign exchange availability MIFFEA. Desired import of food (or other goods) can be realized only if the country has sufficient foreign exchange to pay for imports. When MIFFEA is less than one, indicating a foreign exchange shortage, imported food IF will be less than the desired import of food DIF.

The multiplier for import of food from foreign exchange availability MIFFEA represents the effect of foreign exchange availability on the importation of food. MIFFEA is a function of foreign exchange availability indicator FAVI. When FAVI is less than one, indicating the existence of a foreign exchange shortage, the country cannot pay for all the goods and services it desires to import. Therefore, as FAVI decreases below one, MIFFEA also drops to decrease the value of imported food, representing restrictions on food importation due to shortage of foreign exchange.

Foreign exchange availability indicator FAVI is a measure of the sufficiency of foreign exchange reserves FE for the foreign trade activities of the nation. FAVI depends on foreign exchange reserves FE and on the average total desired imports ATDI. When foreign exchange reserves FE is adequate to cover the average total desired imports ATDI over a certain period of time (say six months), the foreign exchange availability indicator will be one. The desired coverage time is represented by a constant called the normal foreign exchange coverage time NFECT. If the reserves FE can cover the average total desired imports ATDI over a period of less than normal coverage time NFECT, FAVI is less than one, indicating a shortage of foreign exchange. As the average total desired imports ATDI rises, the required pool of foreign exchange reserves must also grow in order to keep pace with rising desired rates of importation.

The average total desired import ATDI represents the recent desired level of foreign trade. More precisely, ATDI is a smoothed value of the recent values of total desired import TDI.

Total desired import TDI is the summation of desired import of food DIF, desired import of consumption goods DICON, desired import of capital goods DICAP, and desired import of intermediate goods DII. The formulation for the desired import of every good is analogous to that of the desired import of food DIF.

The desired import of food DIF is the amount of food that the nation desired to import. DIF is food output FOUT times the fraction for

import of food FIF.

The fraction for import of food FIF is the fraction of food output desired to be imported. FIF is determined by the ratio of the demand output discrepancy to the output for food RDODOF (which indicates excess supply or demand for food) and governmental imports policy. For example, when the ratio of the demand output discrepancy to the output for food RDODOF is one, it indicates that domestic demand is one hundred percent more than domestic supply. If the government does not impose any restriction (such as a tariff or quotas) on the importation of food, the fraction for import of food FIF would equal one. Desired import of foods DIF will become 100 percent of the food output, an amount equivalent to the excess demand in the food market. However, the government might decide to protect domestic food producers and encourage expansion of the agricultural sector. Therefore, the government might impose restrictions on food importation. The import restrictions would imply that total desired food imports are less than the difference between domestic demand and domestic supply.

To simulate this restriction in the model, the fraction for import of food FIF is set less than the ratio of demand output discrepancy to output for food RDODOF. In the current example, when the government imposes restrictions on the importation of food, FIF is set less than one. Therefore, desired import of food will become less than demand output discrepancy for food.

The ratio of demand output discrepancy to output for food RDODOF is a measure of domestic supply relative to domestic demand. RDODOF is based on demand output discrepancy for food DODF and food output:

$$RDODOF = \frac{DODF}{FOUT} = \frac{DDF - FOUT}{FOUT}$$

The demand output discrepancy for food DODF is simply the discrepancy between domestic demand for food DDF and food output. When domestic demand for food DDF is greater (or less) than food output FOUT, the ratio of demand output discrepancy to output for food RDODOF will be positive (or negative). A positive value of RDODOF indicates that importation of food is necessary to satisfy domestic demand. A negative value of RDODOF points out that there is some excess supply of food available for exportation. The desired amount of imports or exports of food is based upon the excess supply or demand for food as well as governmental policies with respect to food importation and exportation.

Exported food EF, shown on Figure 3.6 as one of the determinants of total exports TE, is the product of average export of food AEF and multiplier for export of food from desired export MEDEF. When MEDEF is above one, exported food EF increases above average export of food AEF, and vice versa.

The multiplier for export of food from desired export MEDEF represents pressures from desired exports to change recent level of exportation. MEDEF is a function of the ratio of desired exports of food

DEF to average export of food AEF. When desired export of food DEF increases relative to average export of food AEF, so does MEDEF in order to increase exported food. However, MEDEF rises with a diminishing rate because expansion of exports is difficult and involves a multitude of tasks. For example, the share in present foreign markets must be increased, new markets must be explored, and trademarks must be presented and established in those new markets. All of the tasks involved in the expansion of export activities involve competition with exporters of other countries as well as domestic producers within the importing nations. Therefore, the expansion of exports is a time-consuming process. A lack of adequate established markets and limited experience on the part of exporters impose restrictions on the possible growth rate of exports. Therefore, when desired export of food DEF rises well above average export of food AEF, MEDEF levels off in order to restrict an overly rapid expansion of exported food EF.

The average export of food AEF is a smoothed value of exported food EF. As EF increases, so does AEF, to indicate a rise in experience of the exporters and an expansion of the established foreign market for domestic food.

The desired export of food DEF is the amount of food that the nation desires to export. DEF is food output times the fraction for export of food FEF.

The fraction for export of food FEF is the fraction of food output desired to be exported. FEF is determined by the ratio of demand



output discrepancy to output for food RDODOF. As RDODOF increases, FEF decreases, and vice versa.

The multiplier for export from foreign exchange availability MEFEA represents the incentives and encouragement provided by the government for exporters. MEFEA depends on the foreign exchange availability indicator FAVI. When foreign exchange availability is low, the government encourages exportation. In the model, an increase in governmental incentive for exportation is represented by an increase in MEFEA.

### 3.7 OIL EXPORTATION

Background: Oil revenue is the major foreign exchange flow into Iran. When the country faces a foreign exchange shortage, the government tries to overcome such a shortage by exporting more oil. Since the world demand for oil is rising, the government can continue to increase exports of oil as long as oil reserves are not exhausted. But when reserves run out there will be no oil to be exported. This section explains the oil exportation mechanism in the model.

General Overview: Figure 3.7 depicts the feedback mechanism that governs oil exportation and domestic oil consumption. Oil exports OILEX and domestic oil consumption DOCO exhaust oil reserves. Oil exportation changes in response to changes in desired oil export. The desired oil export is based on average oil exports, foreign exchange availability, and restrictions from reserves. One goal of the mechanism

is to keep foreign exchange availability at normal levels. When a foreign exchange shortage appears, the foreign exchange availability indicator FAVI falls below one. Oil exports OILEX are, then, raised in order to increase oil revenues OILREV. As oil revenues rise, so do total exports TE to restore the normal availability of foreign exchange. However, as oil reserves are depleted, the reserve restrictions on exportation and domestic consumption rise. When oil reserves become less than the reserves required to maintain a normal coverage of the average oil exports, the multiplier for export of oil from reserves MEOR drops, thereby decreasing oil exports OILEX. For domestic consumption, as oil reserves relative to domestic demand for energy DDE drops, the oil availability indicator OAVI falls. A low oil availability indicator OAVI points to a domestic oil shortage and restricts domestic oil consumption.

Description of the Structure: Oil reserves, shown in Figure 3.7, are depleted by oil exports OILEX and domestic oil consumption DOCON.

Oil exports OILEX is set equal to exogenous demand for oil EDO from 1959 to 1977. Exogenous demand for oil EDO represents the actual oil exports during 1959-1977. After 1977, oil exports OILEX is equal to exports of oil EO which is determined endogenously in the model.

Exports of oil EO is an adjusted value of average exports of oil AEO. The adjustment is based on multiplier for oil exports from desired export MOEDE. When MOEDE increases, so does exports of oil EO relative to average exports of oil AEO, and vice versa.

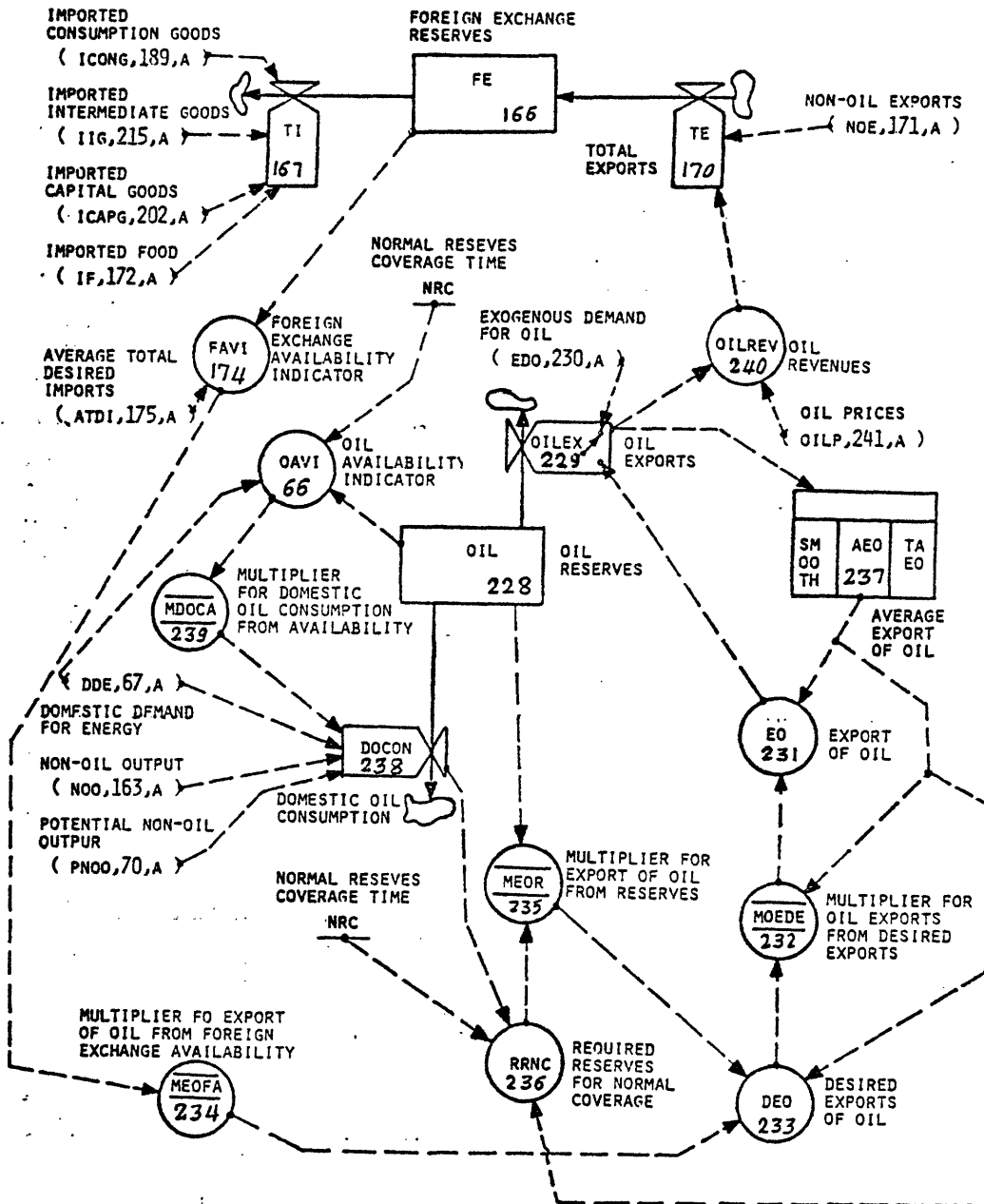

Figure 3.7: Oil Exportation

The multiplier for oil exports from desired export MOEDE represents pressures from desired exports to change recent level of oil exports. MOEDE is a function of the ratio of desired exports of oil DEO to average exports AEO. When desired exports of oil DEO rises relative to average exports of oil AEO, MOEDE will increase, and vice versa. Because international demand for oil is growing and, in the future, there will be no restrictions on oil exports from the demand side, expansion of oil exports in response to desired exports is a matter of governmental policy. The government may increase oil exports in accordance with desired oil exports. Alternatively, the government may restrict growth of oil exports at a certain level regardless of pressures from desired exports. Different governmental policies will be examined in Chapters 4 and 5.

Desired exports of oil DEO represents desired level of exports based on pressures from availability of foreign exchange and oil reserves. Desired exports of oil DEO is an adjusted value of average exports of oil AEO. The adjustment is based on multiplier for export of oil from foreign exchange availability MEOFA and multiplier for export of oil from reserves MEOR. As MEOR and MEOFA increase, so does desired exports of oil DEO relative to average exports of oil AEO.

The multiplier for export of oil from foreign exchange availability MEOFA represents the effect of foreign exchange availability on desired exports of oil. MEOFA is a function of the foreign exchange availability indicator FAVI. When FAVI is less than one, i.e., a foreign

exchange shortage exists, MEOFA will be more than one, to represent pressures to increase oil exports and restore foreign exchange availability. As long as there is no restriction from reserves, desired exports of oil increases in response to high pressures from foreign exchange availability.

The foreign exchange availability indicator FAVI indicates the availability of foreign exchange. As was discussed in the last section, FAVI depends on foreign exchange reserves FE and average total desired imports ATDI.

Foreign exchange reserves FE, also discussed in the previous section, is decreased by total imports TI and increased by total exports TE.

Total exports TE are the sum of different exported goods and oil revenues OILREV.

Oil revenues, currently a major source of foreign exchange, are oil exports OILEX times oil price OILP.

Oil price is exogenous to the model. Different assumptions about changes in future oil prices, measured relative to the price of Iran's imported goods, can be made. The implication of each assumption can be examined using the model.

The multiplier for export of oil from reserves MEOR, another determinant of desired exports of oil DEO, represents the reserve restrictions on DEO. MEOR is a function of the ratio of oil reserves OIL to required reserves for normal coverage RRNC. When oil reserves OIL

become less than the reserves required for normal coverage time RRNC, MEOR will be less than one to represent a restriction on export from reserves and a consequent lessening of oil exports. When oil runs out, i.e., oil reserves become zero, the multiplier for export of oil from reserves MEOR becomes zero and no oil can be exported.

The required reserves for normal coverage RRNC indicates the reserves necessary to supply the recent average level of oil exports and domestic demand for energy over some desired period of time. Required reserves for normal coverage RRNC is based on average exports of oil AEO, domestic demand for energy DDE, and desired reserves coverage time DRC. As average exports of oil AEO and domestic demand for energy DDE increase, RRNC rises to indicate that larger reserves are required to cover the recent value of oil exports and domestic demand for energy over the desired reserves coverage time DRC.

The average exports of oil AEO represents the recent values of yearly oil exports. AEO is a smoothed value of oil exports OILEX.

In addition to exports, as shown in Figure 3.7, domestic oil consumption also decreases the oil reserves. Domestic oil consumption DOCON depends on domestic demand for energy DDE and the multiplier for domestic oil consumption from oil availability MDOCA. As domestic demand for energy DDE increases, so does DOCON, given that a low availability of oil does not restrict the consumption. If as a result of oil shortage in the country, MDOCA becomes less than one, domestic oil consumption will drop below the domestic demand for energy DDE.

The multiplier for domestic oil consumption from oil availability MDOCA represents the effect of oil availability on domestic consumption. MDOCA is a function of the oil availability indicator OAVI. When OAVI becomes less than one, indicating a scarcity of oil for domestic consumption, MDOCA will decrease below one to reduce the domestic oil consumption DOCO below domestic demand for energy DDE.

The oil availability indicator OAVI, as discussed in Section 3.3, is based on oil reserves OIL, domestic demand for energy DDE, and required reserves coverage time for production RRCP.

### 3.8 POPULATION STRUCTURE AND CHANGE

Background: The demographic sector interacts with the production sectors of the economy. Population produces the labor force, a basic and classical production factor in the economic literature. Population also provides children for educational processes. School age children in the population are the group that the educational system can educate and turn into an educated labor force. Education, embodied in people, increases the productivity of the nation and accelerates the development process. On the other hand, the output of economic activities influences the behavior of the demographic sector. As development takes place, per capita output and consumption increase. The education level of the population rises and the rate of growth of the population changes. When development occurs, the standard of living and health services increase, death rate falls, and the rate of growth of the

population rises until further development decreases birth rates and reduces the growth rate. This section discusses the structure which is designed to reflect, in an aggregate manner, the interaction between economic growth and development on the one hand and the rate of change of population on the other.

General Overview: Figure 3.6 depicts the DYNAMO flow diagram of the population sector in the model. Population is divided into three groups: pre-school children PSC, school-age children SAC, and adult population AP. Due to aging process, pre-school children flow into school-age children; school-age children flow into the adult population. Birth rate BR increases pre-school children. Each group of population is decreased by its corresponding death rate. Birth rate is based on adult population, education level, industrialization, and food per capita. Death rate in each category depends on the population size of that category, the effects of food per capita and industrialization on death rate. As shown in Figure 3.8, the population sector also provides labor which depends on the size of population.

Description of the Structure: As shown on the top of Figure 3.8, population POP consists of pre-school children PSC, school-age children, and adult population AP. Pre-school children PSC are those in the zero-to-six-years-old categories. School-age children SAC are those older than six who have not yet joined the adult population to participate in the labor force. Adult population AP represents those who have passed their childhood period and joined the labor force.



Each age category is changed by its inflow and outflow rates. Birth rate BR increases pre-school children PSC. Death rate of pre-school children DRPSC and flow of pre-school children to school-age children PSSA decrease pre-school children PSC. Flow of pre-school children PSSA to school-age children increases school-age children SAC. Death rate of school-age children DRSAC and flow of school-age children to adult population SAA decrease school-age children SAC. Flow of school-age children to adult population SAA increases adult population AP, and the death rate of adult population DRAP decreases the adult population AP.

Birth rate BR depends on adult population AP, the normal birth rate, the multiplier for birth rate from food MBRF, the multiplier for birth rate from industrialization MBRI, and the multiplier for birth rate from education level MBREL.

The normal birth rate NBR expresses birth rate as a fraction of the adult population when food per capita, industrial output per capita, and education level are at their 1974 values, taken as normal condition.

The multiplier for birth rate from food MBRF is a function of food per capita FPC. Food per capita FPC is based on total food TF and population POP. When food per capita FPC increases, the health of the people improves, due to better nutrition. As the health condition improves, the fecundity of the adult population increases. Thus the birth rate would rise unless the population decides, based upon factors other than food, to keep it low. Therefore, in the model, as food per capita FPC increases, so does the multiplier for birth rate from food.

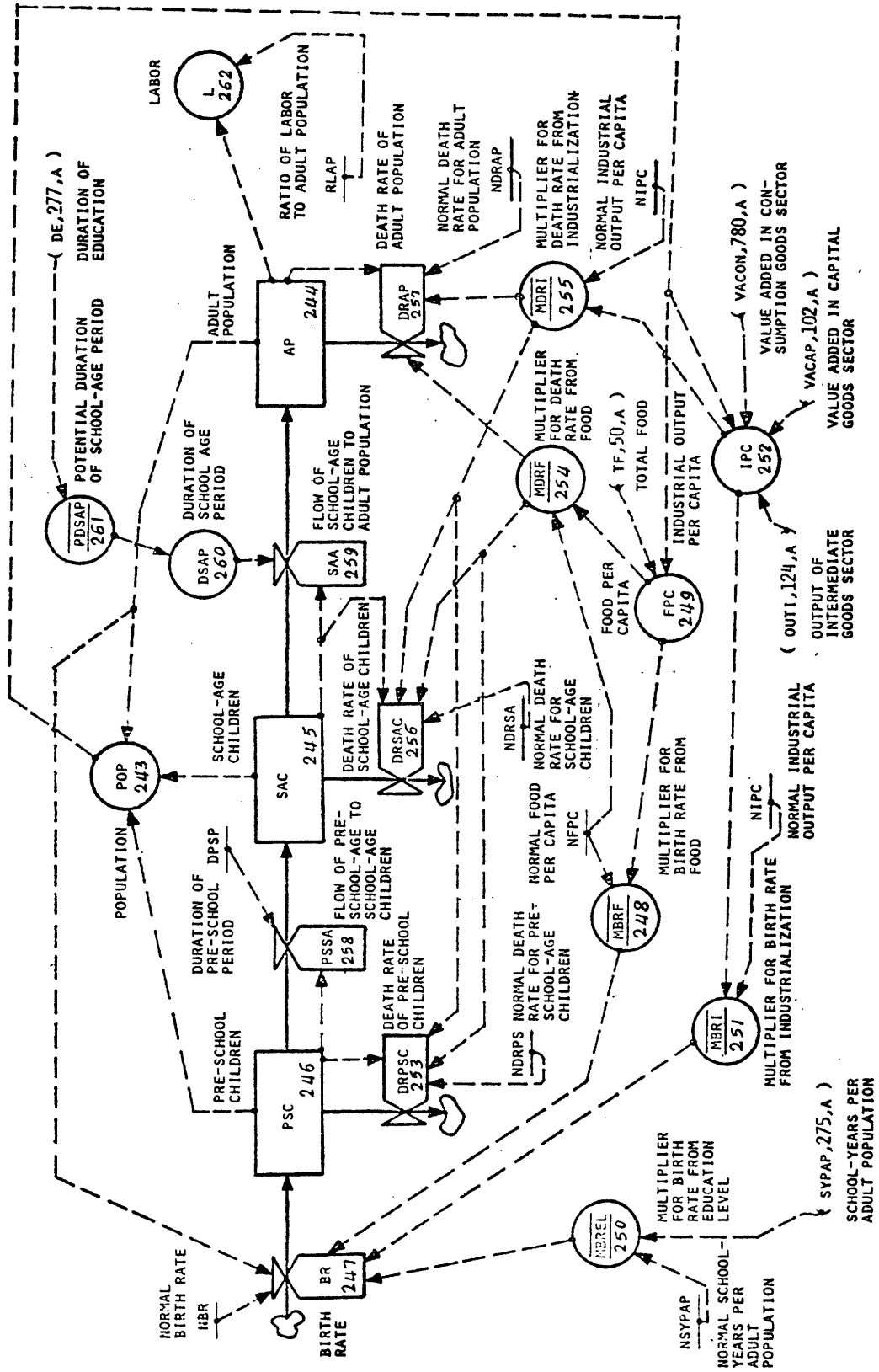

Figure 3.8 : Population Sector

Another influence on the birth rate is industrialization. The multiplier for birth rate from industrialization MBRI is a function of industrial output per capita IPC. IPC is the ratio of output of the industrial sectors to population. Industrial output per capita IPC represents the level of industrialization: as industrialization takes place, IPC rises. Industrialization creates incentives to reduce the birth rate and provides the technology to do so. Some of the factors generating these incentives in industrialized nations are: retirement plans and insurance health services, more sophisticated education and training required for children, and increased mobility of youth away from their families. Retirement plans and insurance decrease the reliance of the elderly on their children. Health services raise the probability of the survival of children. The training and education of children become increasingly sophisticated and require more parental efforts and attention. Increased mobility tends to break down the extended family structure, thereby discouraging large families. These factors and several others, from the social setting of an industrialized nation, create the incentives to have less children per family, thereby decreasing the birth rate.

In addition, industrialization provides the necessary birth control technology to achieve the lower birth rate which is desired by the society. In the model, the multiplier for birth rate from industrialization MBRI, which represents the effect of industrialization on the birth rate, decreases as industrial output per capita IPC rises.

The final influence on birth rate in the model is from education. The multiplier for birth rate from education level MBREL represents the effect of education on the birth rate. MBREL is a function of school years per adult population SYPAP. SYPAP represents the average education level of the society. Education facilitates rationalization and adoption of new norms for family life, replacing the traditional norms. New norms, such as the emancipation of women and other factors mentioned before, require a lower birth rate and smaller family size. Also, education facilitates the spread of information and the application of birth control methods in order to lower the birth rate. Therefore, as the education level rises, birth rate drops. This inverse relationship between birth rate and education has been documented in the literature as shown in a survey by Mary G. Powers (1975) pp. 252-257. To reflect the effect of education on birth rate in the model, the multiplier for birth rate from education level MBREL decreases as school years per adult population rises.

Death rate in each of the three groups depends on the population in that group, nutrition, and the level of industrialization. Death rate in pre-school children DRPSC is proportional to the pre-school population PSC; death rate in school-age children DRSAC is proportional to school-age children; death rate in adult population DRAP is proportional to adult population AP. Under normal conditions, e.g., nutrition and industrialization in 1974, the proportional factor for pre-school children is the normal death rate for pre-school children NDRPS, the

factor for school-age children is the normal death rate for school-age children NDRSA, and the proportional factor for adult population is the normal death rate for adult population. When nutrition and industrialization differ from normal, so do the proportional factors.

The multiplier for death rate from food MDRF represents the effect of nutrition on the death rate of different groups of the population. MDRF is a function of food per capita FPC. When food per capita FPC increases, indicating an improvement in nutrition, the multiplier for death rate from food MDRF drops and the death rate in each group of the population decreases.

The multiplier for death rate from industrialization MDRI represents the effect of industrialization on the death rate. MDRI is a function of industrial output per capita IPC which is an indicator of the level of industrialization. As the society industrializes, the supply of health services increases, and the death rate drops. In the model, when industrial output per capita rises, the multiplier for death rate from industrialization MDEI decreases to reduce the death rates in the different groups of the population.

In addition to death rate, outflow of children from their age group decreases the population of that group. Flow from pre-school to school-age children is proportional to pre-school children. The proportional factor is the reciprocal of the duration of the pre-school period DPSP, assumed to be six years. Flow from school-age children to adult population is based on school-age children SAC and the duration of the school-age period DSAP.

Duration of school-age period DSAP, through potential duration of school-age period PDSAP, depends on the average duration of education in the educational system DE. The relationships are such that when duration of education DE is less than 8 years, DSAP will be 8 years; therefore children join the adult population AP to participate in the labor force at the age of 15. However, when the duration of education DE becomes greater than 8 years, the duration of school-age period DSAP will also rise above 8 years, and children stay in the school-age group for more than 8 years.<sup>6</sup>

As school-age children join the adult population, they are ready to participate in the labor force. Labor L is based on adult population AP and ratio of labor to adult population RLAP. RLAP indicates the labor participation of the population. Labor participation is assumed to be constant in the model.

In summary, the structure shown in Figure 3.8 and explained in this section is designed to capture the major interactions between the demographic and production sectors. Population provides labor for economic activities, and economic output influences the size and structure of the population. Industrial output, total food, and the education level of the population are the major determinants of birth rate and death rate.

### 3.9 EDUCATION SECTOR AND GROWTH OF EDUCATION LEVEL

Background: Education is essential to economic growth and development. The modern era of economic growth, distinguished from the preindustrialization period, is recognized by economists (such as Kuznets (1966) Chapter 1) as the era of application of science in production activities. To apply science in economic activities, education becomes a necessity. As a survey by M.G. Bowman (1966) indicates, economists recognize the contribution of education to economic growth. Education increases the ability of the labor force to recognize the deficiencies in production processes and to resolve them. Education expands the capacity of people to innovate. In developing countries, education raises the ability of nations to transfer technology from advanced countries and accelerate their economic growth rates.

In addition to its contribution to the economic growth, education influences the lifestyle of individuals. The effect of education on birth rates was mentioned in the previous section. Education, through writing and reading, opens a new world of communication to educated people and creates new and exciting horizons of intellectual exploration. Because of its contribution to economic growth and its influence on societal values and lifestyles, education becomes an integral part of the process of growth and development.

Education is provided by the education sector. The sector admits school age children and educates them. Individuals who graduate from the sector increase the education level of the country. Expansion

of the education system is essential to economic growth and development. The sector grows to satisfy the demand for education. Demand for education increases as income and education level of population rise.

The government can stimulate the demand - e.g., by providing free education, thereby accelerating the growth of the sector. Expansion of the education system places demands upon scarce production resources. In order to expand, the sector must hire its required resources from the total available to the nation for all production activities. Thus, the education sector must compete for resource acquisitions with other production sectors. As the sector grows, it accelerates the growth rate of the education level of the country and increases the production capacity of the nation. This section explains the structure of the education sector of the model.

General Overview: Figure 3.9 illustrates the education sector of the model. The education level  $E$  is raised by the rate of increase of education  $RIE$ .  $RIE$  depends, among other factors, on the termination rate  $TR$  in the education system.  $TR$  is a delayed value of the admission rate  $AR$ . The period of the delay is the duration of education,  $DE$ . The admission rate is mostly based on the social demand for education  $SDE$  and enrollment capacity  $ECAP$  of the education system.  $ECAP$  depends on the production capacity in the education sector  $PCE$  and the necessary production capacity per enrollment ratio  $PCEC$ .  $PCE$  is a fraction of production capacity in industrial sector  $PCIS$ . The fraction of



production capacity in education sector FPE changes gradually in response to a change in the desired production capacity in education sector DPE. DPE, in turn, varies in response to the variation of the availability of enrollment capacity AVEC. AVEC is a measure of enrollment capacity  $e_{cap}$  relative to social demand for education SDE. SDE is essentially based on school-age children SAC, the desired enrollment ratio DER, and duration of education DE. Both DER and DE are determined by school-year per adult population SYPAP and GNP per capita GNPPC. SYPAP is the ratio of education E to adult population AP.

Description of the Structure: Education E, measured in man-years of schooling, represented the amount of schooling embodied in people. E is raised by the rate of increase of education RIE and decreased by the (rate of) reduction of education RE.

The reduction of education RE is the rate with which the death rate of educated people decreases the education level of the country. The education level E decreases as educated people die and take with them the amount of education which they carry. The death rate of adult population, as was explained in the previous section, is formulated to be proportional to the adult population and adjusted by the effect of nutrition and industrialization. In a similar way, the reduction of education RE is based on the level of education E, normal death rate for adult population NDRA, the multiplier for death rate from food MDRF, and the multiplier for death rate from industrialization MDRI. Therefore, when food availability or industrialization changes the death rate of the

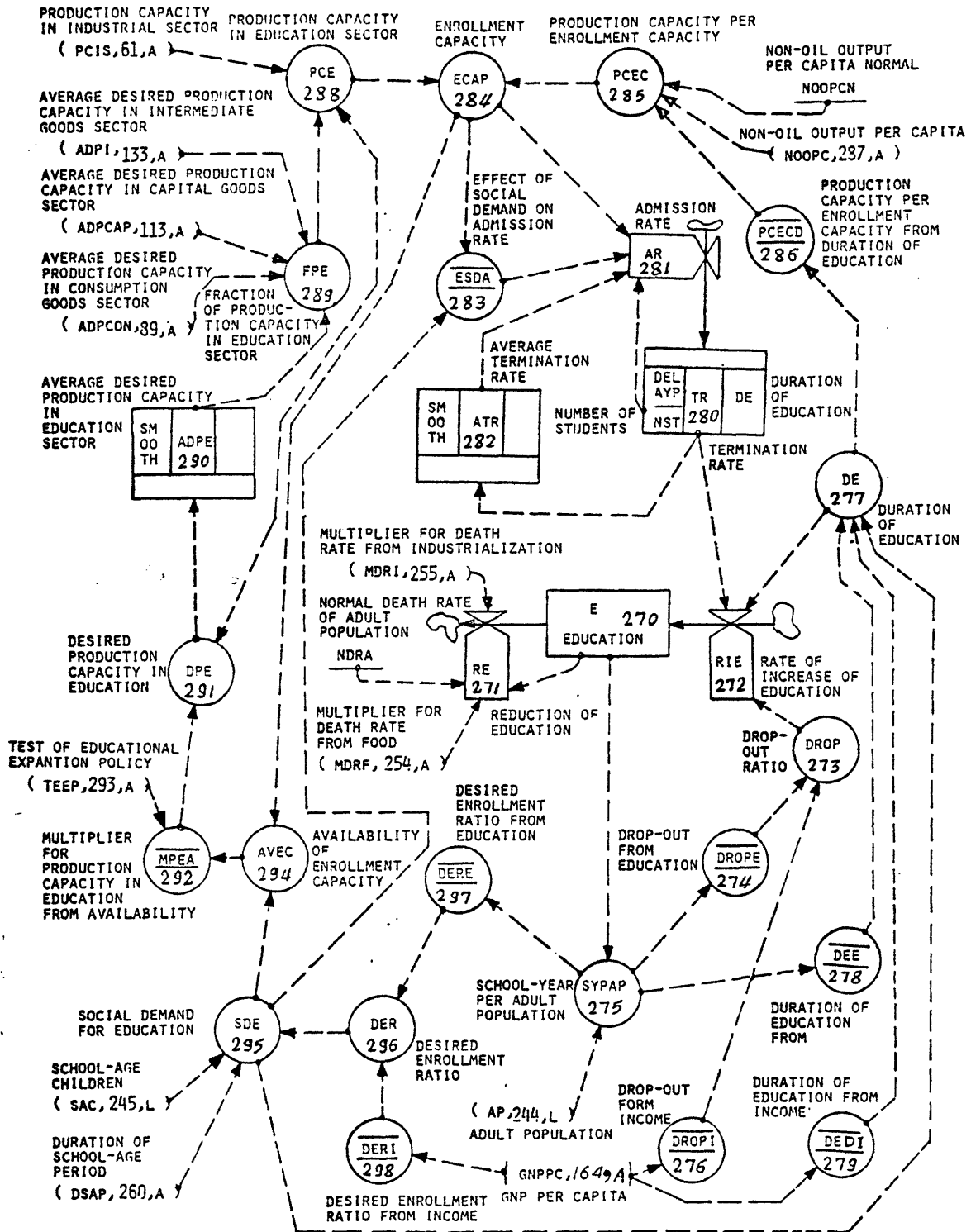

Figure 3.9: Education Sector

adult population, a similar change will be reflected in the rate of reduction of education RE.

The rate of increase of education RIE is the amount of effective education which is embodied in those who leave the education system each year. RIE depends on the number of students who leave the education system, their average level of education, and the effectiveness of their education. From those who terminate their education, some are graduates. The graduates are those who leave the school system when they finish primary school, the first cycle of the secondary school, or universities. However, besides graduates, in the developing countries, many students drop out of school before they graduate from their educational institutes. The students who drop out before they finish their educational programs do not contribute to the rate of increase of educational proportional to their years of schooling. For example, children who drop out of school during the first three or four years of the primary school usually relapse into illiteracy a little later. Therefore, the rate of increase of education RIE is based on the termination rate TR, duration of education DE, and the drop-out ratio DROP.

The drop-out ratio DROP represents the fraction of students who drop out of the school system in different educational levels. Drop-out ratio is high when income and educational level of people is low. As income and educational level increase, people become more concerned about the education of their children, more able to afford the cost of

education, and more capable of persuading their children to continue their educational programs; therefore, the drop-out falls. Drop-out ratio DROP in the model is an arithmetic average of the drop-out from education DROPE and drop-out from income DROPI.

Drop-out from education DROPE presents a value for drop-out ratio based on the education level of population, DROPE is a function of school-years per adult population SYPAP, which is the ratio of education E to adult population AP. As people, on the average, become more educated and SYPAP increases, DROPE falls.

Drop-out from income DROPI suggests a value for drop-out ratio based on the income level of population, DROPI is a function of GNP per capita GNPPC. As GNPPC increases, indicating a high income per capita, DROPI decreases.

The duration of education DE is another determinant of the rate of increase of education RIE. DE represents the average period that each child stays at school. Duration of education DE, like drop-out, depends on the level of education and income of the parents. As the level of income and education of adults increases, so does the duration of education which they demand and can afford for their children. Duration of education DE is an arithmetic average of the duration of education from education DEE and the duration of education from income DEI.

The duration of education from education DEE suggests a value for DE based on the education level of population, DEE is a function of

school-year per adult population SYPAP. As people become more educated and SYPAP increases, so does the duration of education from education.

The duration of education from income DEI presents another value for the duration of education based on income level. DEI is a function of GNP per capita GNPPC. As GNPPC rises, so does DEI.

The termination rate TR, the other determinant of RIE, is the number of students who leave the education system each year. The termination rate is a delayed value of the admission rate AR. The period of the delay is the duration of education. The pipeline stock in the delay is the number of students NST.

The admission rate AR represents the number of new students who are admitted to the school system each year. The education sector admits new students in order to: (1) replace those who terminate their education or graduate each year, and (2) adjust the total number of students to the available enrollment capacity as long as the capacity does not exceed the number of children who are demanding education (i.e., social demand for education). In the model, the admission AR is based on the average termination rate ATR, enrollment capacity ECAP, the number of students NST, and the effect of social demand on admission rate ESDA.

Average termination rate is a smooth value of the termination rate TR representing those students who terminate their education each year. These students should be replaced through admissions.

The effect of social demand on admissions rate ESDA represents the restriction that an inadequate level of social demand would impose on

the admission rate. ESDA is a function of enrollment capacity ECAP and social demand for education SDE. If available enrollment capacity exceeds the social demand for education, the effect of social demand on admission rate ESDA will reduce the admission rate in order to bring admission into line with the number of applicants who are demanding to be admitted to the education system.

Enrollment capacity ECAP in the education system depends on the production capacity in education sector PCE and the required production capacity per enrollment capacity PCEC in the sector. If PCE increases relative to PCEC, so does enrollment capacity (and visa versa).

Production capacity per enrollment capacity PCEC represents the amount of production capability - measured in terms of real equivalent of output per year - that the nation should allocate to the education sector in order to increase the capacity of the education system by one unit. PCEC is an adjusted value of the production capacity per enrollment capacity from duration of education PCECD in 1974 educational costs. The adjustment is based on the ratio of non-oil output per capita NOOPC to the value of NOOPC in 1974 - i.e., non-oil output per capita normal NOOPCN.

The production capacity per enrollment capacity from duration of education PCECD is that of 1974. PCECD is a function of the duration of education PE. As the average duration of education rises, so does the average necessary production resources to support each student. University education costs more than high school education. High school

is more expensive than the primary school education. Therefore, as DE increases, so does PCECD.

Non-oil output per capita NOOPC is an indicator of opportunity cost for the production resources used in the education sector. When NOOPC increases, so does the cost of resources in the education sector. A university graduate working in the education sector of a poor country is paid much less than a similar graduate working in the education sector of a rich country. Therefore, production capacity per enrollment capacity PCEC increases when non-oil output per capita in the country rises.

The production capacity in education sector PCE, the other determinant of enrollment capacity ECAP, is a fraction of production capacity in industrial sector PCIS. PCE represents the production capability - in terms of rials equivalent of output per year - that the nation allocates to the education system. PCE is equal to the production capacity in industrial sector PCIS times the fraction of production capacity in education sector FPE.

The fraction of production capacity in education sector FPE is a function of the average desired production capacity in education, in intermediate goods, in capital goods and in consumption goods sectors (ADPE, ADPI, ADPCAP, and ADPCON respectively). As the average desired production capacity in education sector ADPE relative to the average desired production capacity in the other sectors increases, so does FPE.

The average desired production capacity in education sector ADPE is a smoothed value of the desired production capacity in education sector DPE. As DPE changes so does ADPE, to affect the fraction of production capacity in education sector FPE. The response of ADPE to the change in DPE is slow because the shift of production resources between the education and the other sectors of the economy is a time consuming process.

The desired production capacity in the education sector DPE is an adjusted value of the production capacity in education sector PCE. The adjustment is based on the availability of enrollment capacity in the education sector. DPE is equal to PCE times the multiplier for production capacity in education from availability MPEA. When MPEA increases, so does DPE relative to the production capacity in education sector PCE.

The multiplier for production capacity in education from availability MPEA represents the effect of availability of education facilities on the expansion of the sector. MPEA is a function of the availability of enrollment capacity AVEC. When AVEC decreases, MPEA increases. Since the operation and expansion of the education system is a government's responsibility, the intensity of the change in MPEA in response to the availability of enrollment capacity AVEC depends on the governmental policy with respect to educational expansion. If the government is very concerned about the educational expansion of the country, a drop in the availability of enrollment capacity would cause



MPEA to rise sharply. Different governmental policies with respect to the expansion of the sector can be examined in the model.

The availability of enrollment capacity AVEC is a measure of the capacity of the education sector relative to demand for education. AVEC is the ratio of enrollment capacity ECAP to the social demand for education SDE.

The social demand for education SDE represents the number of children that the society desires to have in school. SDE is based on school-age children SAC, duration of school-age period DSAP, duration of education DE, and desired enrollment ratio DER. When the duration of education DE increases, school period covers a larger number of children who could potentially be in school and increases the social demand for education SDE. SDE also increases when the population of school-age children SAC and/or the desired enrollment ratio DER rise.

The desired enrollment ratio DER represents the ratio of children whom society demands to put in school to the number of children who potentially could be in school, based on their age group. The desired enrollment ratio DER depends on the level of education and income of population. As average income and education level increases, more and more people demand education for their children and desired enrollment ratio DER rises. DER is an arithmetic average of the desired enrollment ratio from education DERE and desired enrollment ratio from income DERI.

The desired enrollment ratio from education DERE presents a value for the desired enrollment ratio based on the education level of population.

DERE is a function of school years per adult population SYPAP. As people become more educated and SYPAP rises, so does DERE. The desired enrollment ratio from income DERI suggests a value for DER based on the average level of income in the country. DERI is a function of GNP per capita GNPPC. As GNPPC rises and people become wealthier, DERI increases.

In summary, the education sector shown in Figure 3.9, and explained in this section, produces education. As income and education level of population rise, demand for education increases. In response to the rising demand, the nation allocates more of its production resources to the education sector to expand it. As the sector expands, it admits and educates more children and therefore increases the education level in the country. The sector, during its expansion, interacts with other parts of the system. The education level, as discussed in the other sections of this chapter, influences the production capability of the nation, the demographic behavior and the rate of technology transfer. In return, the performances of the other sectors affect the expansion of the education sector.

### 3.10 TECHNOLOGY TRANSFER

Background: Growth of production factors such as capital, labor, and amount of education (viewed as human capital) are not the only determinants of economic growth. Technological progress also has been recognized as an important determinant.<sup>7</sup> Technological progress represents improvement in the processes of production, in the quality of

capital equipment, in technical and managerial know-how, and in social and political organizations to increase economic output. In Iran, from 1959 to 1974, about 40% of the growth of industrial output could be attributed to technological progress.<sup>8</sup> As technological progress takes place, the level of technology advances.

The level of technology in different countries differs. Some countries, such as the United States, are at the frontier of technological development and advance the frontier. Other countries follow the advanced ones; there is a "technological gap" between pioneers and followers. As Daniel L. Spencer (1970) indicates, "technology gap" is established as a valid and useful concept in the literature. Theoretically, the gap between two countries can be identified by comparing their aggregate production functions.<sup>9</sup> A technologically superior country with the same amount of the same inputs produces more than a backward country. The technological gap indicates that the advanced countries have developed a pool of technology which has not yet been completely used by the developing countries. This pool of unutilized technology is a valuable source to the less developed nations. They can transfer technology from that pool to stimulate their technological progress and economic growth.

The rate of transfer of technology to a nation depends upon (1) the amount of available technology not yet utilized by the nation, i.e. technological gap, and (2) the ability of the nation to transfer that technology. The capability of a nation to transfer technology is

determined by its ability to perceive technological information, to understand that information, to adopt the new techniques, and to become technically and socially adapted to the new technology. The most important determinant of such ability is recognized to be the educational level of the nation.<sup>10</sup> Modern technology can hardly be translated to an illiterate society. Education is essential to the process of perceiving technological information, understanding and evaluating the information, and selecting the appropriate technology to be adopted. Adoption and implementation of the new technology cannot be accomplished by an illiterate work force. A better educated work force is more adaptable to technical change in production.

Technological information flows into a country through different channels. Printed materials such as books, journals, and technical reports provide an important channel for transmission of information. These printed materials, at an international level, are readily available to those who can read, understand, and use them. Technical information also flows between nations via flow of goods and services, direct contact between people of countries with different levels of technology, and purchase of license and patents. Foreign trade with technologically advanced countries can stimulate all the above transmission mechanisms. Therefore, as foreign trade of a nation with more advanced countries rises, the rate of transfer of technology to that nation should be stimulated. The dependency of the rate of technology transfer upon

technological gap, education level, and foreign trade is the foundation of the formulation of the transfer of technology in the model.

General Overview: Figure 3.10 shows the structure that governs the transfer of technology to the industrial sector of the economy. A similar structure is formulated to regulate the level of technology in the agricultural sector. As shown in Figure 3.8, the technology in industrial sector TIS is increased by the rate of technology transfer in industry RTTI. RTTI depends basically on technology in the industrial sector of advanced countries TISA, technology in (domestic) industrial sector TIS, foreign trade, and education level. The technology in industrial sector of advanced countries TISA is assumed to grow with an endogenous rate of technological progress RTP. The effect of foreign trade on the technology transfer is a function of total imports TI relative to non-oil output NOO. The effect of education on the technology transfer depends on the level of technology relative to a normal level implied by the average education level of industrial workforce represented by school years per laborer in industry SYPLI.

Description of the Structure: Technology in industrial sector TIS is an index of the level of technology in the industrial sector of the economy. TIS is increased by the rate of technology transfer in industry RTTI.

The rate of technology transfer in industry RTTI is based on technology in the industrial sector of advanced countries TISA, technology in (domestic) industrial sector TIS, normal time for catching



up in industrial technology NTIT, the multiplier for technology transfer from education in industry MTTEI, and the multiplier for technology transfer from foreign trade MTTFT.

Technology in the industrial sector of advanced countries TISA is exogenous to the model. TISA represents the level of technology in those countries who are at the frontier of technological development. The model assumes that the technology in advanced countries grows exponentially at a constant rate, called rate of technological progress in industry RTPI.

The normal time for catching up in industrial technology NTIT represents the necessary time for the country to advance its technology to the present level of technology in advanced countries when foreign trade and the education level of industrial workers are at their normal levels. NTIT depends on, among other factors, the ratio of technology in industrial sector of advanced countries TISA and technology in domestic industrial sector TIS, which is called the technology ratio in industrial sector TERIS. Based on TERIS and the rate of technology progress RTPI, one can determine how much time is necessary for the country to advance its technology to the present level of technology in advanced countries with a rate of advancement equal to RTPI. But, since Iran does not develop the technology, but rather mostly transfers what is already developed, the necessary time to advance its technology to the present level of TISA is less than the time implied by TERIS and RTPI. Therefore, in the model, the normal time for catching up in industrial

technology NTIT is based on the technology ratio in the industrial sector TERIS, the rate of technology progress RTPI, and a coefficient for technological progress through transfer CTPT. CTPT shortens the normal time for catching up in technology relative to the time implied by TERIS and RTPT because it takes less time to achieve technological progress through transfer than via direct development.

The multiplier for technology transfer from foreign trade MTTFT is another determinant of the rate of technology progress in industry RTTI. MTTFT represents the effect of foreign trade on technology transfer. MTTFT is a function of foreign trader ratio FTR. FTR represents the intensity of foreign trade activities and is the ratio of total imports to non-oil output NOO. When foreign trade activities increases, the flow of technology embodied in foreign goods and services increases, direct contact with foreign technologists per population rises, and the required competition of domestic producers with imported goods intensifies. All of these effects of foreign trade activities stimulate the transfer of technology. Therefore, in the model, when foreign trade ratio rises, so does the multiplier for technology transfer from foreign trade MTTFT in order to increase the rate of technology transfer in industry TRRI.

The effect of education level on the rate of technology transfer in industry RTTI is formulated in the multiplier for technology transfer from education in industry MTTEI. MTTEI is a function of the ratio of technology normal to technology ratio in industry TNTRI, indicating the



technology in the sector implied by the education level of its labor force relative to its actual technological level. If the actual technological level in the sector is less than what the educational level of its employees implies - i.e, if TNTRI is greater than one - then the rate of technology transfer accelerates, and visa versa. In the model, as TNTRI increases, so does the multiplier for technology transfer from education in industry MTTEI.

Technology normal to technology ratio in industry TTNRI is the ratio of technology normal in industry TNI to technology in industrial sector TIS. When the technology normal to industry TNI increases relative to TIS, technology to technology normal ratio in industry TTNRI rises, and visa versa.

The technology normal in industry TNI represents a level of technology which the average education of the labor force implies. If the labor force in the sector is totally illiterate, then the technology level correspondent to such labor force is very low and primitive. On the other hand, if the labor force in the sector is as educated as the labor force of advanced countries, then they have the capability of understanding and practicing the available highly advanced technology. Then, the technology normal in industry TNI correspondent to such highly educated labor force will be high. TNI, in the model, is equal to the technology in industrial sector of advanced countries TISA times the technology index for industry TEII.

The technology index for industry TEII indicates a normal ratio of the industrial technology of the country to the industrial technology of the advanced countries based on the educational levels of their industrial work forces.

The technology index for industry depends on the school years per laborer in (domestic) industry SYPLI and the school years per industrial laborer of advanced countries SYPILA. As the school years per laborer in industry SYPLI relative to SYPILA rises, so does the technology index in industry TEII. When SYPLI equals SYPILA, the technology index for industry becomes one. A value of one for TEII indicates that the labor force in the industrial sector is educationally capable of understanding and adopting the technology being practiced in the advanced countries.

The school year per laborer in industry SYPLI represents the average school-year embodied in each laborer working in the sector. SYPLI is equal to the education in industrial sector EIS divided by the labor in industrial sector LIS. As education in industrial sector EIS relative to LIS increases, so does SYPLI.

In summary, advancement in technology is one of the determinants of the growth of economic output. Technological progress in Iran, like other developing countries, can be stimulated through transfer. The rate of technological progress and transfer depends upon the level of education and foreign trade with more advanced countries. The structure depicted in Figure 3.10 governs the technological progress in the

industrial sector. A similar structure, explained in the appendix, regulates the advancement of technology in agriculture. The mechanism embodied in Figure 3.10 keeps the technological and educational level of the country roughly in balance. When the technology is lower than the level correspondent to the education of the labor force, the rate of technology transfer is stimulated to increase the level of technology more rapidly. On the other hand, when the level of technology is higher than what the education level implies, the rate of technology transfer decelerates. Further technology transfer is inhibited by an insufficient level of education. The structure shown in Figure 3.10 also reflects the influence of foreign trade on the rate of technology transfer. As total imports of foods and services rise, the transfer of technology is stimulated, and vice versa.

FOOTNOTES

- 1 For the theory of optimal allocation of production factors between different productive activities, see James M. Henderson and Richard E. Quandt (1958), chapter 7.
- 2 For optimal allocation of factors in perfect competition see Ibid. pp. 262-264.
- 3 For such an argument, see U. Lange, "On the Economic Theory of Socialism" in B. Lippincott, ed. On the Economic Theory of Socialism, Minneapolis, 1938 and 1948.
- 4 For a collection of economic growth theories, see A. Sen ed., (1970) or Joseph E. Stiglitz and Hirofumi Uzawa eds., (1967).
- 5 For empirical studies on the pattern of allocation of income in different levels of per capita income, see Chenery (1975) or Kuznets (1966), Chapter 5.
- 6 For a detailed description of the relationships, see the Appendix A.
- 7 For the point that growth of production factors are not the only determinant of growth of output and that the contribution of technological progress to the growth of output is substantial, see R.M. Solow (1957) pioneer paper and/or among others Kirk Hayashi (1971) and E.F. Denison (1967).
- 8 For the growth of determinants of industrial output in Iran, see Ali N. Mashayehi (1977).
- 9 For this method of measurement of the gap see Jan Kmenta (1967), p. 40.
- 10 For such recognition see, for example, Jan Kmenta (1967), p. 43, and R.R. Nelson (1964).

## CHAPTER 4

### ON THE TRANSITION INTO AN OIL-INDEPENDENT ERA: HOW AN ECONOMIC CRISIS MIGHT OCCUR

Government's policies will determine the smoothness of the transition of the economy into an oil-independent era. This chapter discusses some policies which could lead to an economic crisis during the transition. The next chapter examines alternative policies to achieve a smooth transition.

#### 4.1 IMPORTANT POLICIES AND ASSUMPTIONS LEADING INTO AN ECONOMIC CRISIS

This section discusses the oil exportation and import policies, which could lead the country into an economic crisis. The policies discussed here are those that when in Chapter 5 are altered, would smooth out the transition. The formulation of these policies is discussed in the previous chapter and Appendix A. The brief reviews in this section aim to bring to the attention of the reader the principles of those policies which are highly related to the discussions in Chapters 4 and 5.

4.1.1 Oil Exportation Policy: From 1959 to 1977, oil exports are exogenous to the model and set equal to the actual exports. After 1977, exportation of oil is formulated as an endogenous policy in the model. As explained in Appendix A, Equations 229-237, oil exports rise as rapidly as desired oil exports. Desired oil exports depend on the recent level of exports, foreign exchange availability, and oil reserves. When foreign exchange availability decreases, desired oil exports are raised relative to the recent level of exports in order to increase foreign exchange revenues and, thus, maintain foreign exchange availability at a normal level.

Desired oil exports are also raised to increase the national income of the country when oil reserves are huge relative to current oil production. The size of oil reserves relative to production is identified by the length of time that reserves can cover current production - i.e., reserves coverage time. Normal reserves coverage time NRC is assumed to be 15 years. As long as oil reserves can cover more than 15 years of current production, desired oil exports will rise to increase national income. When oil reserves cover less than 15 years of current production, reserve restrictions decrease oil exports.

4.1.2 Import Regulations Policies: Imports of any goods - i.e., food, consumption, intermediate, or capital goods - are based on domestic demand, domestic supply, import regulations, and foreign exchange availability. When foreign exchange availability is low due to foreign

exchange shortage, actual imports would be lower than desired imports. Desired imports of each good is formulated based on domestic demand, domestic supply and the government's importation policies. The different policies, simulated in this chapter, are discussed next. The exact formulation of import policies is explained in Chapter 3 and Appendix A.

Food Imports: No restriction is imposed on food importation (see Equations 178 and 178.2 in Appendix A). Desired import of food is set equal to the difference between domestic demand and domestic output of food when demand exceeds domestic supply.

Consumption Goods Imports: Some restriction is imposed on importation of consumption goods (see Equations 192 and 192.2 in Appendix A). Imports of consumption goods include importation of conventional consumer goods, services and arms. Although imports of conventional consumer goods such as refrigerators, TV sets, and cars are currently highly restricted, there is no restriction on imports of services, arms and arms related services imported by the government. Therefore, in this chapter, some restriction is imposed on aggregate consumption goods.

Capital Goods Imports: No restriction is imposed on importation of capital goods (see Equations 205 and 205.2 in Appendix A).

Intermediate Goods Imports: No restriction is imposed on importation of intermediate goods either (see Equations 218 and 218.2 in Appendix A).

4.1.3 Oil Prices: Price of oil is exogenous to the model. From 1959 through 1976, price of oil is set equal to the actual real price of oil during that period. The actual price of oil during 1959-1976 is determined by dividing deflated oil revenues by oil exports. Oil revenues are deflated by the 1972 deflator of imported goods and services to Iran. In the first simulation, the price of oil in real terms is assumed to be constant after 1976 (see Equation 241 in Appendix A).

4.1.4 Oil Reserves: At the end of 1976, Iran's proven oil reserves was 63 billion barrels. If accumulated oil production from 1959 through 1976 is added to reserves at the end of 1976, the value of reserves at the beginning of 1959 is obtained as 83.8 billion barrels. However, in the model, the value of reserves is initialized at 100 billion barrels in 1959. The initial value of reserves is set at 100 billion barrels in order (1) to account for possible reserves to be found in the future, and (2) to account for possible natural gas exports by the country during the simulation period. Simulation has shown that neither the dynamic behavior of the model nor the conclusions of the study are sensitive to a wide variation of the initial value of oil reserves. The initial value of reserves will be kept constant through all simulations in the next two chapters.

4.1.5 Limits to the Growth Rate of Non-Oil Exports: The rate of expansion of non-oil exports of the country is limited. Non-oil exports



include exports of foodstuff, consumption goods, intermediate goods, and capital goods. Exports of each good increase when desired exports exceed the value of average exports of that goods during the previous year, and vice versa. However, the expansion of non-oil exports is a hard, time-consuming and competitive process at the international level. Therefore, throughout simulation in this study, it is assumed that non-oil exports of the country in the long run can not grow more than 10% per year in real terms (i.e., constant prices). In fact, this assumption might be an optimistic one. Table 4.1 shows the growth of exports of some developed and developing countries during 22 years from 1950 through 1972 in current prices. As the table shows, for the majority of countries, even at current prices, the growth of exports is less than 10% per year. It does not seem wise to discuss the strategy of development in Iran based on any more optimistic assumptions about the maximum long-run growth of non-oil exports than what is assumed here. Especially when industrial development in Iran has been oriented towards highly stimulated and protected domestic markets, a 10% per cent annual growth of non-oil output in real terms is not easy to achieve.

4.1.6 Imports Substitution: Imports substitution is one of the important determinants of the expansion of consumption, capital, and intermediate goods sectors in all simulations presented in Chapters 4 and 5. The decision for expansion of each sector depends not only on demand and supply in the marketplace, but also on the share of domestic output

Table 4.1  
 Growth Rate of Exports at Current F.O.B. Prices in  
 Some Developed and Developing Countries  
 During 1950-1972.

<u>Country</u>	<u>1950</u>	<u>1972</u>	<u>Average Growth Rate</u>
Austria	325.5	4487.3	11.9
Belgium	1652.6	16139.2	10.3
Brazil	3.3	18.0	7.7
Canada	2897.2	20341.4	8.8
Chile	283.2	855.4	5.0
Czechoslovakia	778.9	4915.2	8.3
Egypt	503.7	825.0	2.2
France	3037.0	25845.8	9.7
West Germany	1976.0	46207.0	14.3
Greece	90.3	870.8	10.3
India	1310.2	2415.1	2.8
Italy	1209.3	18606.7	12.5
Japan	820.0	25891.0	16.1
Mexico	465.5	1824.9	6.2
Morocco	663.6	2952.9	6.8
Norway	2789.0	21625.0	9.3
Pakistan	488.6	697.9	1.6
Philippines	331.0	1177.8	5.8
Portugal	185.7	1293.8	8.8
Spain	389.5	3803.2	10.3
Sweden	1102.9	8767.3	9.4
Turkey	263.4	884.9	5.5
United Kingdom	6325.2	24345.5	6.1
United States	10282.0	49779.0	7.1
Yugoslavia	154.3	2237.2	12.1

Source: United Nations Yearbook of International Trade, 1974.

in total supply. When the share of domestic output of a sector in total supply decreases, a rise in imports substitution possibilities accelerates expansion of that sector. For expansion of all sectors, imports substitution possibilities are weighted as much as market availability of a sector's output - i.e., market effect coefficients for all sectors in Equations 96.1, 119.1 and 139.1 of Appendix A are set equal to 0.5. This assumption implies that Iran follows a strong imports substitution policies for expansion of all industrial sectors.

In summary, this section explained different important assumptions and policies that are simulated in the "BASIC" run presented in this chapter. These policies would lead to an economic crisis as discussed in the next section. Some of these policies will be altered to improve the behavior of the model. Alternative policies and resultant behavior will be discussed in the next chapter.

#### 4.2 THE BASIC RUN: HOW AN ECONOMIC CRISIS MIGHT OCCUR

Figures 4.1a through 4.1f show the behavior of the model simulating the policies described in the previous section. Figure 4.1a depicts GNP, non-oil output, GNP per capita, food per capita, and foreign exchange availability indicator. The gap between GNP and non-oil output represents oil revenues. Oil revenues, which rose sharply in 1973, keep rising until about 1984 when the peak of oil exports, shown in Figure 4.1c, occurs. After 1985, restrictions from reserves decrease oil

\* \* \* \* \*

### READING THE COMPUTER PLOTS AND UNITS

The figures in Chapter 3 and 5 are drawn over graphic plots taken directly from the computer. The horizontal scale is in years. At the left margin is a line giving the plotting symbols. For example, in Figure 4.1a, GNP=1 means that the GNP is plotted on the graph with the symbol 1, NOO=2 means that non-oil output NOO is plotted with the symbol 2. The vertical scales at the left of the plot are marked at the top end with the plotting symbols to which they apply. For the numerical values on the scales, M indicates millions and T indicates thousands. For example, in Figure 4.1a, the first scale running from 0 to 10M - i.e., from 0 to 10 million - is the scale for variables plotted with the symbol 1 and 2. Along the top of the graph, the symbol groups indicate where curves overlap. For example, in Figure 4.1a at 1978, the symbols 35 means that the curves for 3 and 5 cross and the first symbol 3 is the one plotted.

Units of each variable in all the figures in Chapters 4 and 5 are the same. Value added, output, and total goods for different sectors are in million rials per year at 1972 constant prices. Therefore, all variables such as GNP, non-oil output, total food, food output, total intermediate goods, intermediate goods output, total capital goods, capital goods output, total consumption goods, consumption goods output, imports and exports are in million rials per year at 1972 constant prices. Availability of foreign exchange and different goods are dimensionless. Oil reserves are in billion barrels. Oil exports and domestic oil consumptions are in billion barrels per year. Population is in persons. School years per adult population is in years of schooling per person.

\* \* \* \* \*

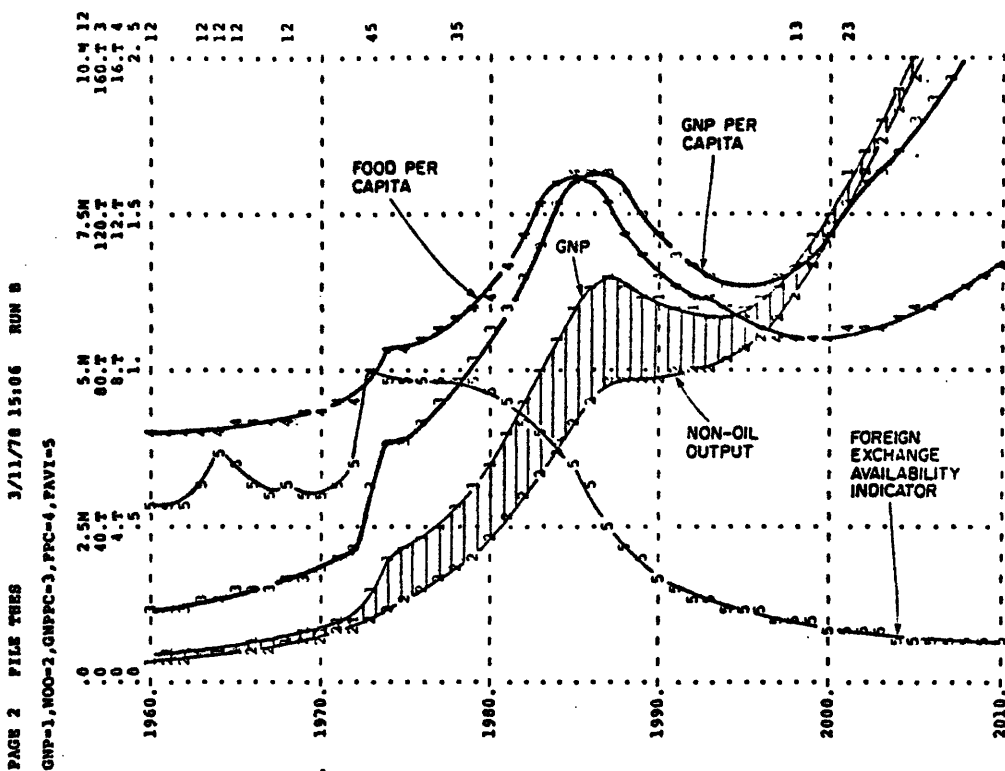

Figure 4.1 a

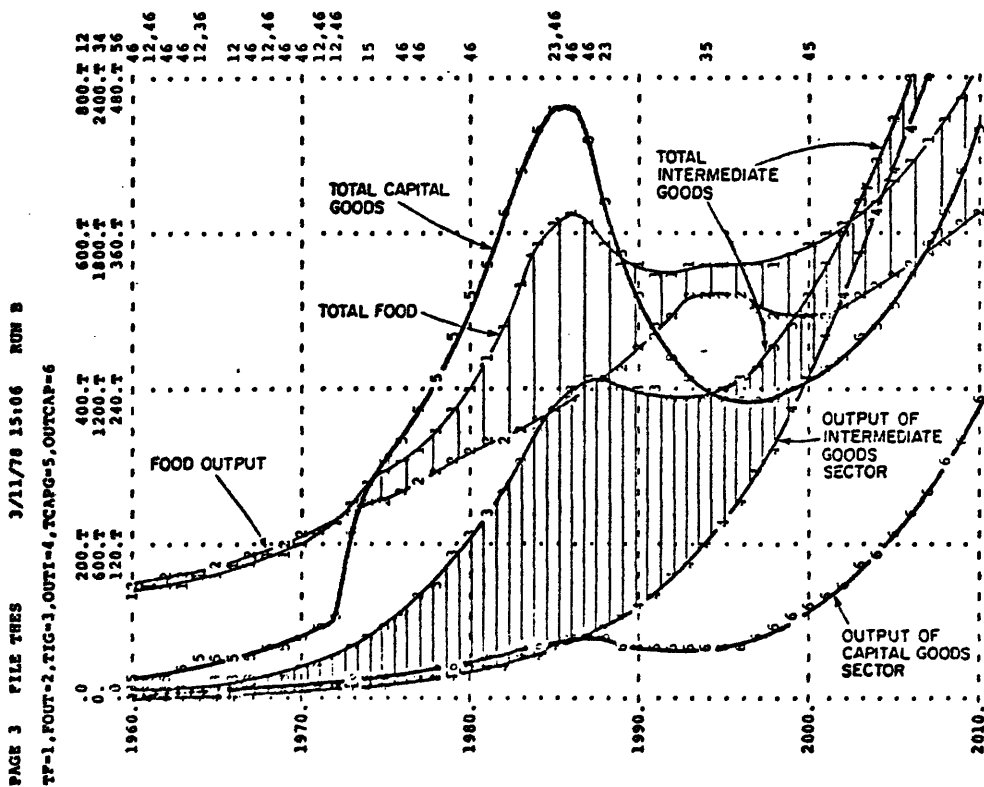

Figure 4.1 b



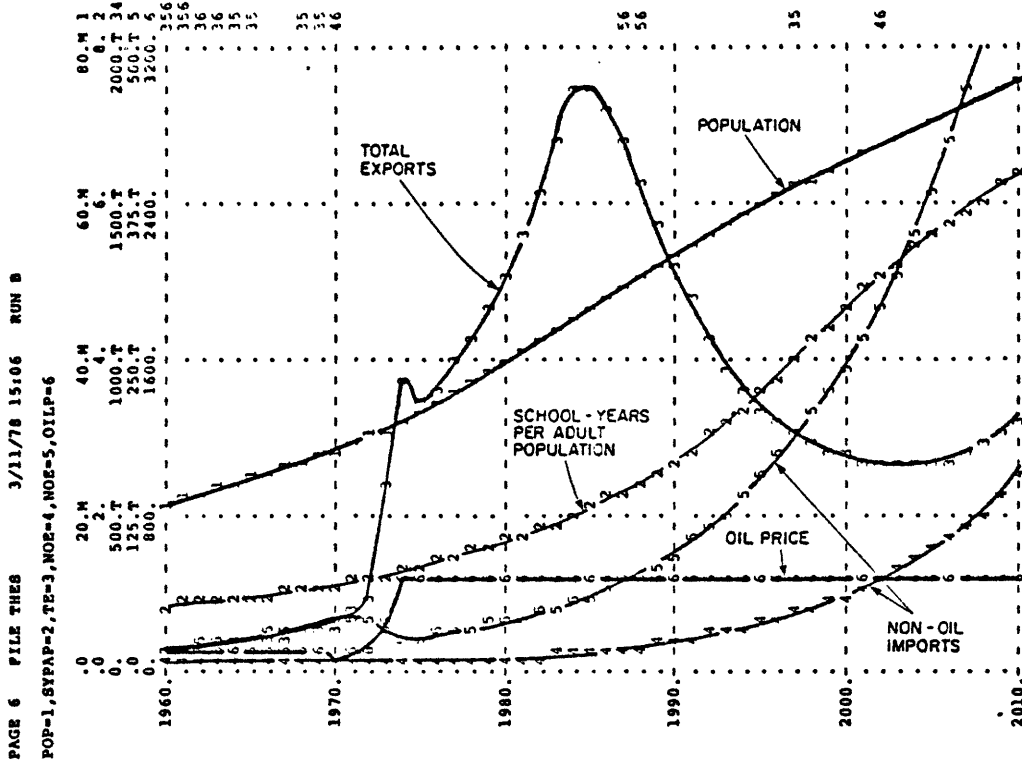

Figure 4.2 e

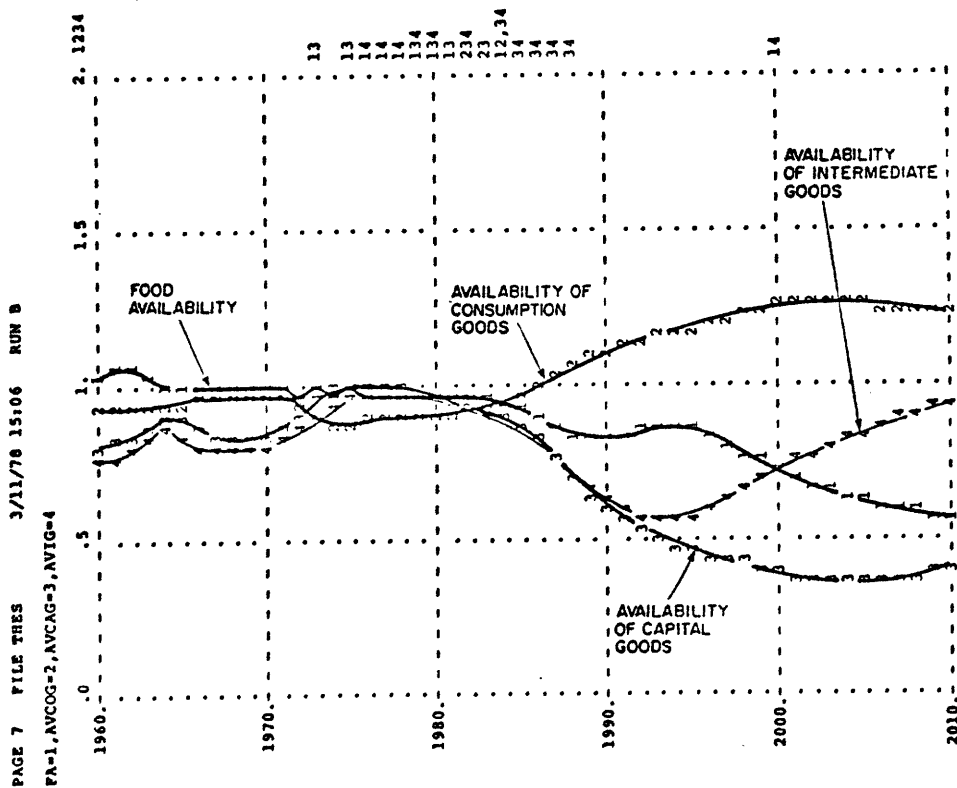

Figure 4.1 f

Figure 4.1: BASIC Run: An Economic Crisis During the Transition.

exports. Oil revenues decline; the gap between GNP and non-oil output lessens. Foreign exchange availability drops, leading to a decline of imports.

Net imports of intermediate goods, the gap between total and domestic output of intermediate goods, shown in Figure 4.1b, declines due to a foreign exchange shortage. In spite of the growth of intermediate goods output, total intermediate goods stop rising after 1986 and even decline slightly until 1994. Availability of intermediate goods, shown in Figure 4.1f, drops after the mid-1980's. Shortage of intermediate goods decreases capacity utilization in the economy and stops the growth of non-oil output from 1987 to 1993.

The stagnation of non-oil output and decline of oil revenues cause GNP to fall after 1987. While GNP declines, population, shown in Figure 4.1e, is rising. Therefore, GNP per capita, in Figure 4.1a, drops more sharply than GNP.

In figure 4.1a, food per capita rises until 1985 and then declines substantially until 1999 when it rises again. Figure 4.1b shows the total food consumed in the country as well as food output during the simulation period. Until 1972, food output was more than total food; net food exports was positive. But rapid growth of GNP per capita as well as population increased food demand well above the output of the slowly growing agricultural sector. Lack of trade restriction on food imports and oil money permit food imports to grow fast in order to satisfy demand. Total food rises above food output after 1972. Net food imports



increases rapidly and keeps food availability, shown in Figure 4.1f, high, close to 1, until 1985. Easily available imported food decreases incentives to expand the agricultural sector. After 1973, the gap between total food and food output widens; Iran becomes more dependent on imported food.

However, after the mid-1980's, when a foreign exchange shortage appears, food imports drop. The gap between total food and food output shortens; after 1985, total food drops. At the same time that total food drops, population, in Figure 4.1e, is rising. Therefore, food per capita, in Figure 4.1a, drops further than total food in Figure 4.1b.

When a food shortage appears after the mid-1980's, the growth of domestic food output, shown in Figure 4.1b, accelerates. Growth of food output continues until 1994 when shortage of oil for domestic consumption decreases the output of, by then, a mechanized domestic agriculture. However, the growth of production factors in the agricultural sector as well as technology improvement in agriculture, raise food output after the year 2000.

In Figure 4.1b, total food rises after 1996 when net food imports increase. After 1996, while food output drops, the growth of population and GNP per capita increase demand for food. Pressures from demand increase imported food and, therefore, total food in the country. However, owing to a foreign exchange shortage, sufficient food can not be imported and, hence, food availability, as shown in Figure 4.1f, falls after 1994.

Figure 4.1b shows the total capital goods and domestic output of capital goods during the simulation. Total capital goods rose sharply in 1973 due to the sudden rise in oil revenue and GNP. Total capital goods and the gap between total capital goods and output of capital goods - i.e., net capital goods imports - keeps rising until 1985, when exports, shown in Figure 4.1c, and oil revenues reach their peaks. After 1986, total capital goods drops because (1) the decline in GNP decreases demand for capital goods, (2) owing to foreign exchange shortage, the required capital goods can not be imported to satisfy demand causing availability of capital goods, shown in Figure 4.1f, to fall, and (3) domestic output of capital goods falls after 1987 due to the intermediate goods shortage appearing thereafter. The decline of total capital goods slows down the growth of capital stock and, hence, the production capacity of the nation. Total capital goods continues to decline until 1995 when the direction of change in total capital goods reverses due to growth of (1) domestic output of capital goods, and (2) net imports of capital goods.

The performance of the consumption goods sector, the other production sector in the model, during the simulation period is depicted in Figure 4.1c. In 1973, the gap between total consumption goods and output of consumption goods rises sharply. The gap represents net imports of consumer goods, arms, and services. The gap starts shrinking as oil exports, shown in Figure 4.1c, reach a peak due to the decline of oil reserves. The gap finally vanishes in the late 1980's while, at the

same time, output of consumption goods drops due to (1) shortage of intermediate goods and (2) insufficient demand for consumption goods as a result of the fall in GNP. In fact, despite the decline in total consumption goods after the mid-1980's, the supply of consumer goods and services exceeds demand, and availability of consumption goods, shown in Figure 4.1f, become more than one. Low domestic demand and pressure from foreign exchange shortage expand exports of consumption goods. Beginning in 1990, net exports of consumption goods become positive; output of consumption goods become larger than total consumption goods used in the country. Net exports of consumption goods increases as the sector recovers and the output starts rising due to (1) expansion of production resources (mostly labor, education, and technology), and (2) rise in availability of intermediate goods as shown in Figure 4.1f.

The growth of consumption goods exports contributes to the rise of non-oil exports, shown in Figure 4.1e. Figure 4.1e shows the performance of total exports as well as non-oil exports of the country during the simulation period. The gap between total and non-oil exports represents oil revenues. As total exports rise sharply in 1973 due to a sharp jump in the price of oil, non-oil exports, shown with two different scales on Figure 4.1e, fall for a few years due to stimulated domestic demand. Total exports and the gap between total and non-oil exports continue to rise until 1985 when oil exports reach a peak. After 1985, total exports fall until 2004 when growth in the value of non-oil exports

is more than the decline of oil revenues and, therefore, total exports rises.

Total exports determine the ability of the country to import. Total imports, shown in Figure 4.1d, has a performance similar to that of total exports. Figure 4.1d shows total imports and imports composition. Total imports and its components rise until 1985, when oil exports reach a maximum. Then, as total exports and oil revenues fall drastically, so do total imports and its components until 2004, when the growth of exports allows the country to raise imports and accelerate the recovery started in the mid-1990's.

After the mid-1990's, the economy starts recovering. Growth of domestic output of intermediate goods, shown in Figure 4.1b, eventually raises total intermediate goods after 1994. At the same time, availability of intermediate goods, in Figure 4.1f, starts to rise. As a result, utilization of production capacity in the economy increases. Therefore, non-oil output starts growing after 1994. The growth of non-oil output is also due to the growth of labor, education, and technology, as well as improvement in industrial productivity, not shown in Figures 4.1. Improvement in productivity is a result of a rise in production experience relative to potential production capacity in the industrial sector after the 1980's. The growth of non-oil output occurs in spite of the devotion of an increasing portion of the production resources of the country to energy production in order to replace, by

then, declining domestic oil consumption, shown in Figure 4.1c, with an alternative energy.

The growth of non-oil output increases GNP after 1995, shown in Figure 4.1a, despite a continuous decline in oil revenues. Growth in GNP raises GNP per capita after 1996.

The behavior illustrated in Figure 4.1a through 4.1f and explained in this section shows an economic crisis that Iran might face as oil runs out. In the behavior shown in this section, the transition into an oil-independent era is not smooth. As oil runs out, GNP and GNP per capita fall; total food and food per capita decline; a foreign exchange shortage appears; total imports drop sharply; the required food, intermediate goods, and capital goods can not be imported and a shortage of intermediate goods causes underutilization of production capacity in the economy. Such an economic crisis is not desirable.

#### 4.3 CAN A RISE IN OIL PRICE SOLVE THE PROBLEM?

In the previous section, the real price of oil was assumed constant after 1976. In this section, the real price of oil is assumed to rise in two different patterns. Neither solves the transition problem.

##### 4.3.1 A 100 PER CENT RISE IN PRICE OF OIL IN 1985

Some studies, such as WAES (1977), predict that in 1985, when a worldwide oil shortage appears, the price of oil might rise sharply. Figure 4.2 shows the behavior of the model with policies used in the

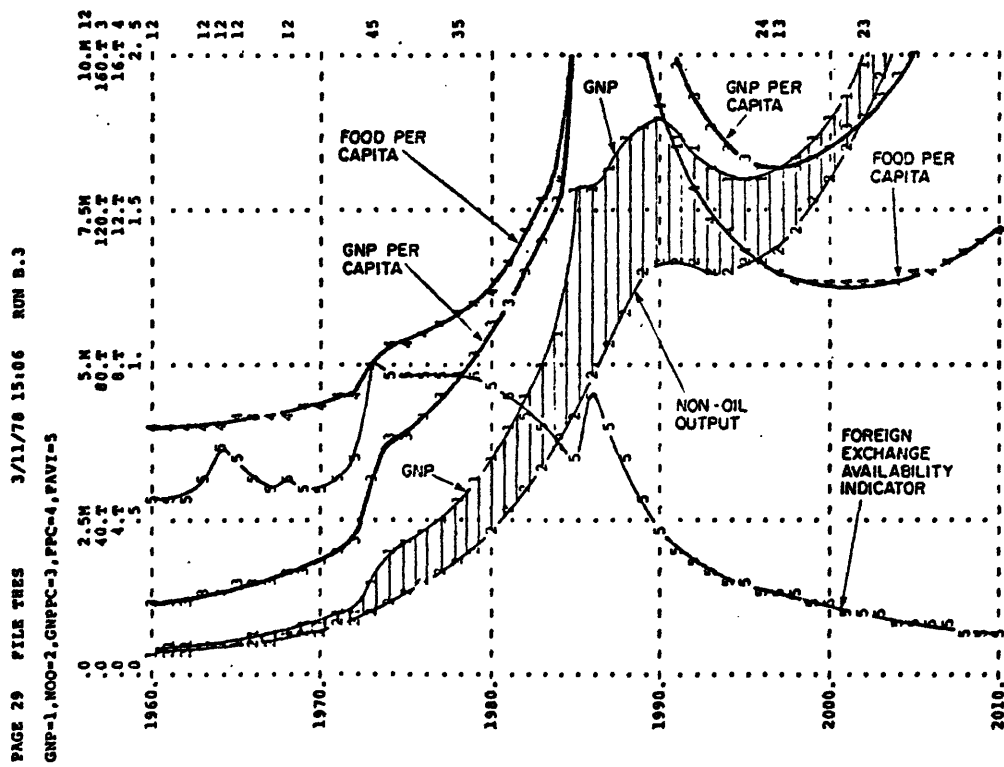

Figure 4.2: BASIC Run Plus a 100 Per Cent Rise in Price of Oil in 1985.

simulation in the previous section and a 100 per cent rise in the price of oil in 1985 (to increase the price of oil by 100 per cent in 1985, parameter STOP in Equation 241 of Appendix A is changed from 0 to 1).

The transition problem does not disappear. GNP and non-oil output fall after 1989. GNP per capita and food per capita rise to higher values than they do in Figure 4.1a and then both fall more deeply.

In 1985, when the price of oil doubles, the gap between GNP and non-oil output, indicating oil revenues, increases twice. Availability of foreign exchange improves. Development based on oil revenues continues further. Continuous growth of non-oil output demands more intermediate goods to be imported. High oil revenues permit imports of intermediate goods to rise and dependency of the economy on imported intermediate goods increases. Growth of GNP per capita increases demand for food. High oil revenues enable the country to increase food imports and eliminate pressures to expand the agricultural sector. The dependency of the country on imported food rises further. In fact, a drastic rise in the price of oil permits the rapid growth of the economy and its dependence on oil revenues continue to a larger degree relative to the case when the price is not raised. And then, when oil revenues decline due to depletion of reserves, the transition problems appear in a larger magnitude than it did when the price of oil was not increased suddenly.

#### 4.3.2 A 5 PER CENT ANNUAL RISE IN THE OIL PRICE AFTER 1980

Figure 4.3 shows the behavior of the model with policies simulated in section 4.2 and a 5 per cent annual rise in the real price of oil after 1980 (to increase the price of oil 5 per cent per year after 1980, parameter TGIPO is changed from zero to one in Equation 241, explained in Appendix A). The performance of the economy is better than the performance with a constant price of oil, shown in Figure 4.1a of the BASIC run. After 1980, the values of GNP and non-oil output in Figure 4.3 are higher than their correspondent values in Figure 4.1a. Non-oil output does not stagnate as it does for a long period of time in Figure 4.1a. However, the transition problems remain, although with a smaller magnitude relative to what is observed in Figure 4.1a. GNP falls slightly after 1990. But, GNP per capita and food per capita fall substantially after 1988 and 1986, respectively.

A five per cent annual rise in the price of oil slows down the decline of oil revenues as oil exports fall. The ability of the country to import its required items does not fall as rapidly as in the case of constant oil price, discussed in the BASIC run in Section 4.2. On the one hand, higher oil revenues permit the economy to increase its dependency on oil income, and, on the other hand, a slower decline in oil revenues provide more time for the country to adjust the economic structure for an oil-independent era. The net result is that the transition problems remain.



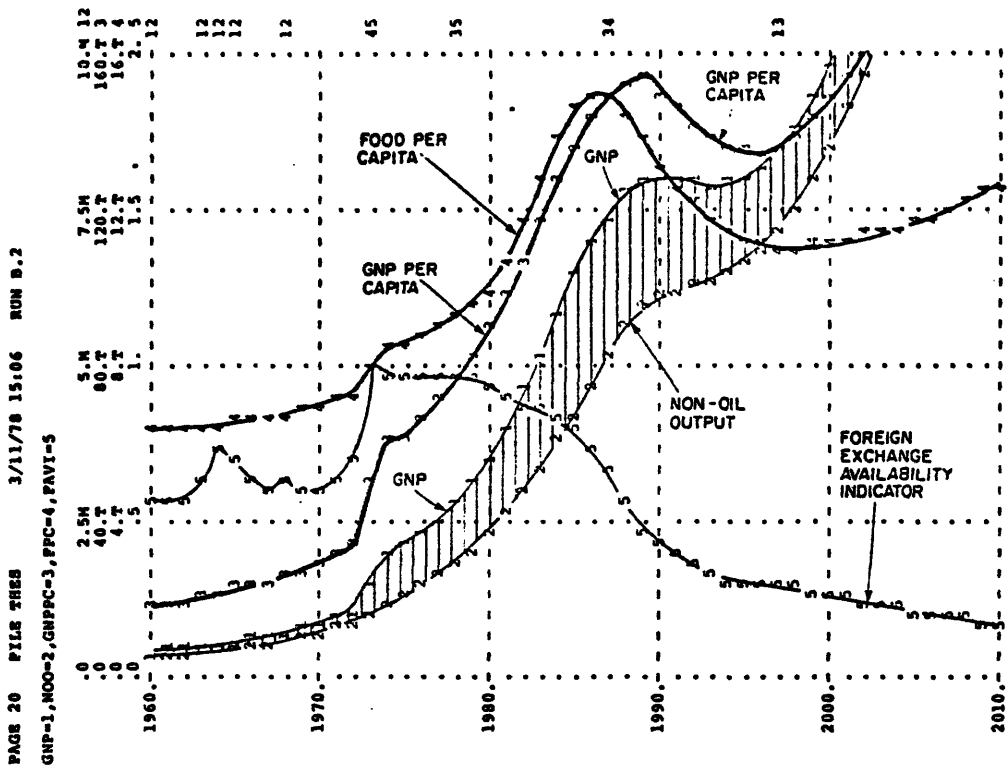

Figure 4.3: BASIC Run Plus a 5 Per Cent Annual Rise in the Price of Oil After 1980.

However, even if a rise in the price of oil was enough to smooth out the transition, it is an insufficient, unwise and risky solution because the price of oil in the international market may not change in the way that Iran desires. New policies should be designed to smooth out the transition on a more certain basis. The next chapter examines several such policies.

## CHAPTER 5

### ON TRANSITION INTO AN OIL-INDEPENDENT ERA: TOWARDS A SMOOTH TRANSITION

This chapter examines alternative policies for a smooth transition to an oil-independent era. The chapter provides a verbal description of each policy which is examined, as well as references to equations that quantify policy changes for model simulations. Except for those policy changes identified in each section of this chapter, the model is simulated with the same policies and assumptions used in the BASIC run that was discussed in the previous chapter. The new behaviors in Sections 5.1, 5.2, and 5.3 of this chapter are explained by comparison to the model behavior in the BASIC run.

#### 5.1 RESTRICTING IMPORTATION OF CONSUMPTION GOODS

Consumption goods imports include conventional goods and services, and arms and arms-related services. In recent years, Iran has been importing a lot of arms. It might appear likely, therefore, that limitation of those imports would solve the transition problem. In this

section, the restriction on importation of consumption goods is increased, relative to the BASIC run, after 1978. With the new policy, an excess of domestic demand over domestic supply of consumption goods leads to a reduction of desired imports of consumption goods relative to the previous policy. Figure 5.1 shows fraction for import of consumption goods FICO as a function of the ratio of demand output discrepancy to output for consumption goods RDODOCO for both the previous and the new policies. FICO represents the desired fraction of domestic consumption goods output to be imported. RDODOCO represents the ratio of excess domestic demand relative to domestic output over domestic output. In Figure 5.1, the solid line illustrates the imports policy simulated in the BASIC run as well as in the present run up to 1978. The dashed curve represents the new policy adopted to increase restrictions on consumption goods imports after 1978. The introduction of this new policy after 1978 is the only difference between the simulation presented in this section and the BASIC run discussed in Section 4.2.

In Appendix A, Equations 189-195 formulate imports of consumption goods including the two different imports policies. To adopt the new policy in the model after 1978, TCOIC (a parameter in Equation 193) is changed from 1 to zero.

Figures 5.2a through 5.2d show the behavior of the model with the new policy. Again, no dramatic changes appear in the behavior. The new policy generates behavior similar to that of the BASIC run, shown in Figures 4.1a through 4.1f, except for some minor changes. In comparison

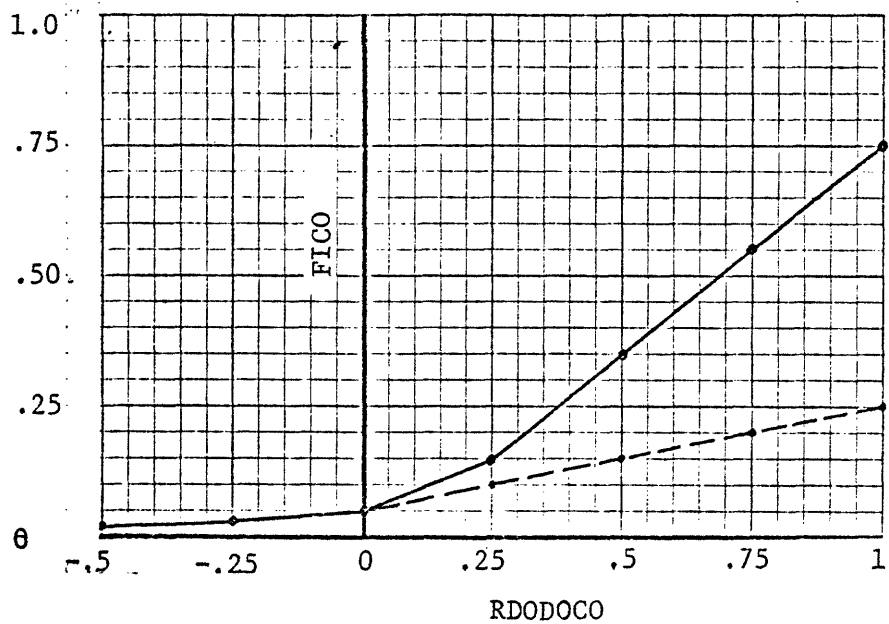

Figure 5.1: Fraction for Import of Consumption Goods FICO Versus the Ratio of Demand Output Discrepancy to Output for Consumption Goods RDOROCO.

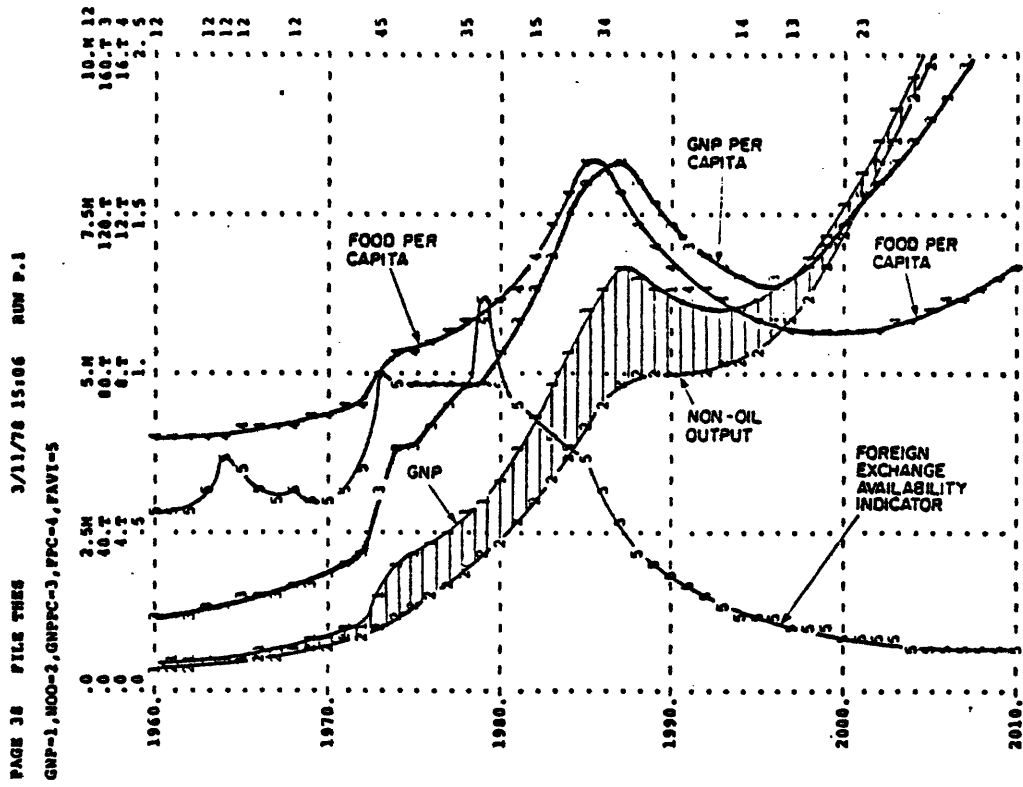

Figure 5.2 a

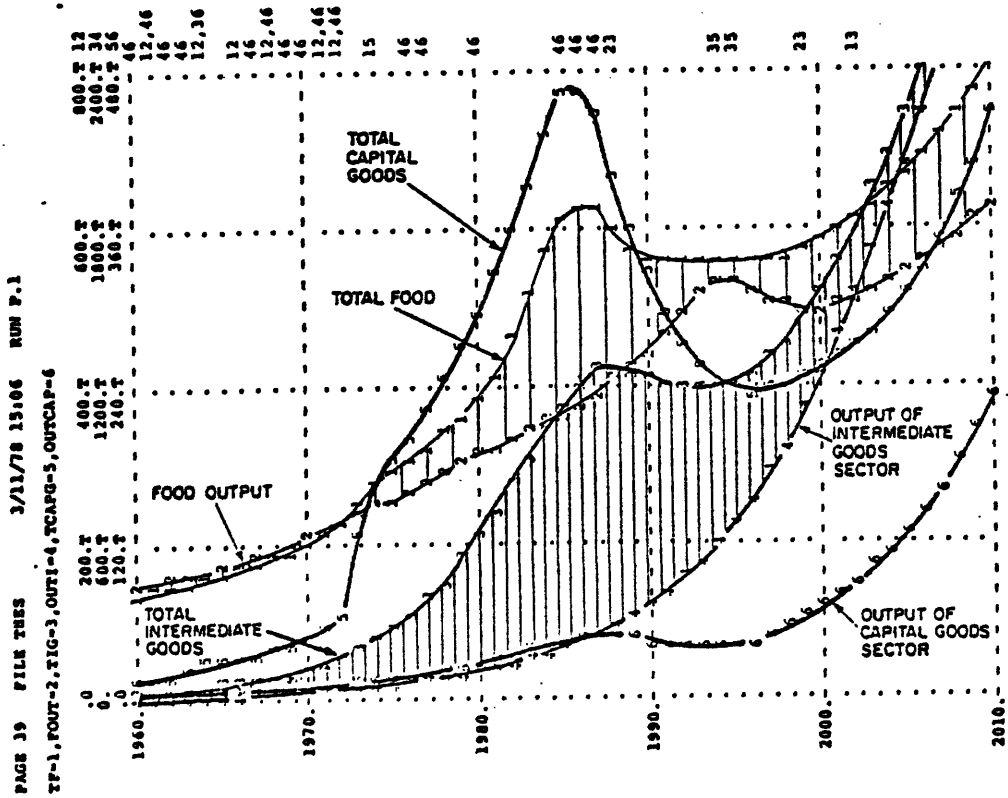

Figure 5.2 b

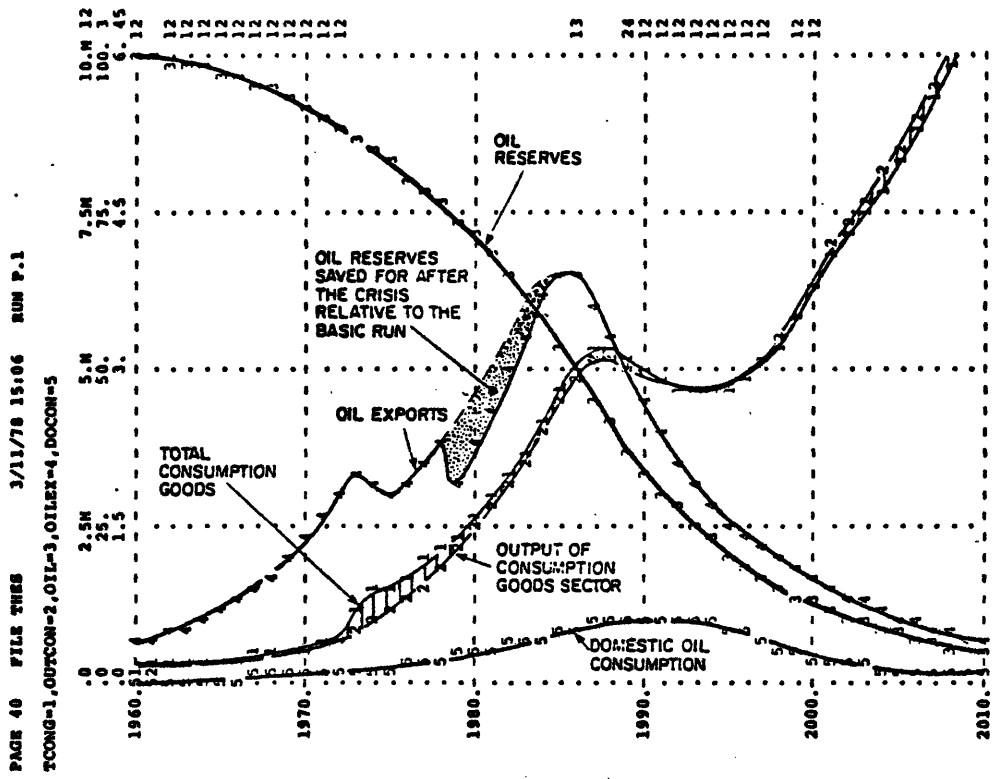

Figure 5.2 c

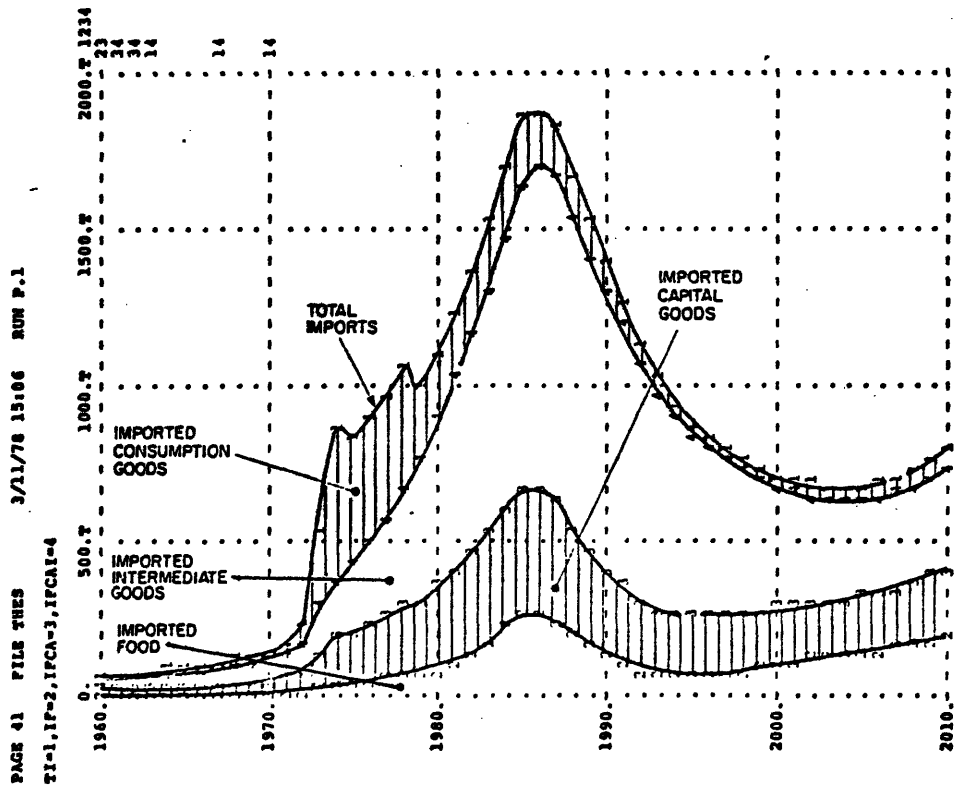

Figure 5.2 d

Figure 5.2: Behavior of the Model with Restrictions on Importation of Consumption Goods.

with the BASIC run, non-oil output grows to a slightly higher value in 1988; GNP, GNP per capita, and food per capita rise to higher maximum values in the late 1980's and then drop to a value not as low as in the BASIC run.

After 1978, when restrictions on importation of consumption goods increase, imported consumption goods (mostly arms and arms-related services) drop as shown in Figure 5.2d. As a result, availability of foreign exchange, shown in Figure 5.2a, rises sharply in 1979. High foreign exchange availability decreases desired level of oil exports. Oil exports drop in 1979 as shown in Figure 5.2d.

But, rapid growth of imported intermediate goods, capital goods, and food, shown in Figure 5.2d, consumes the foreign exchange surplus. Foreign exchange availability drops after 1979, as illustrated in Figure 5.2a. Foreign exchange revenues should rise to finance rapidly growing imports. Oil exports increase, in Figure 5.2c, to supply increasing foreign exchange requirements.

However, oil exports, after dropping in 1979, remain lower than oil exports in the BASIC run until 1985. As a result, some of the oil reserves, represented by the shaded area in Figure 5.2c, are saved during 1979-85 to be exported later. The amount of oil saved during 1979-84 permits, after 1985, oil exports in Figure 5.2c to be slightly higher than oil exports in the BASIC run shown in Figure 4.1c.

Higher exports of oil increase foreign exchange revenues and, hence, the ability of the nation to finance its required imports of



intermediate goods, food, and capital goods after 1986, when the economic crisis begins. Slightly higher imports of intermediate goods allows non-oil output to grow and stagnate at a slightly higher level in Figure 5.2a than it does in Figure 4.1a of the BASIC run. After 1986, higher values of non-oil output and oil revenues raise GNP and GNP per capita in this run above their correspondent values in the BASIC run. Also, higher food imports raise total food and food per capita in this run above those of the BASIC run after 1986.

In summary, the improvement resulting from the new policy - i.e., decreasing importation of consumption goods after 1978 - is very small. Without introducing the new policy, with policies and assumptions used in the BASIC run, Iran will have to decrease imports of consumer goods and arms after 1985, as shown in Figure 4.1d, due to the decline in oil exports and the resulting foreign exchange shortage. Introduction of the new policy reduces imports of consumption goods and exports of oil required to finance imports relative to the BASIC run only during 1979-85. Reduction of oil exports during 1979-85 saves Iran some oil to be exported later when the crisis occurs. As a result, the performance of the model improves slightly after the crisis. Beginning in the mid-1980's, GNP, GNP per capita and food per capita have higher values than they do in the BASIC run without the new policy. However, the amount of oil saved during 1979-85 is far less than enough to eliminate the crisis. GNP, total food, GNP per capita, and food per capita fall

precipitously during the mid-1980's. Some additional policies should be examined.

## 5.2 RESTRICTING IMPORTATION OF FOOD

This section examines a new policy that increases restrictions on food imports after 1978. In the BASIC run, an increasing dependence on imported food led into a dramatic decline in total food and food per capita when the crisis occurs. In that run, no restrictions existed on food imports - i.e., an excess demand over domestic supply of food led to an equivalent desired import of food. But with the new policy in this section, an increase in excess demand for food does not lead into an equivalent rise in desired imports of food because restrictions on food imports are increased.

Figure 5.3 shows fraction for imports of food FIF as a function of the ratio of demand output discrepancy to output for food RDODOF. The solid line represents the imports policy simulated in the BASIC run as well as in the present run up to 1978. The dashed curve represents the new policy adopted to increase restrictions on food imports after 1978. The introduction of this new policy is the only difference between the simulation presented in this section and the BASIC run discussed in Section 4.2.

In Appendix A, Equations 172 to 181 formulate imports of food including the two different imports policies. To adopt the new policy in

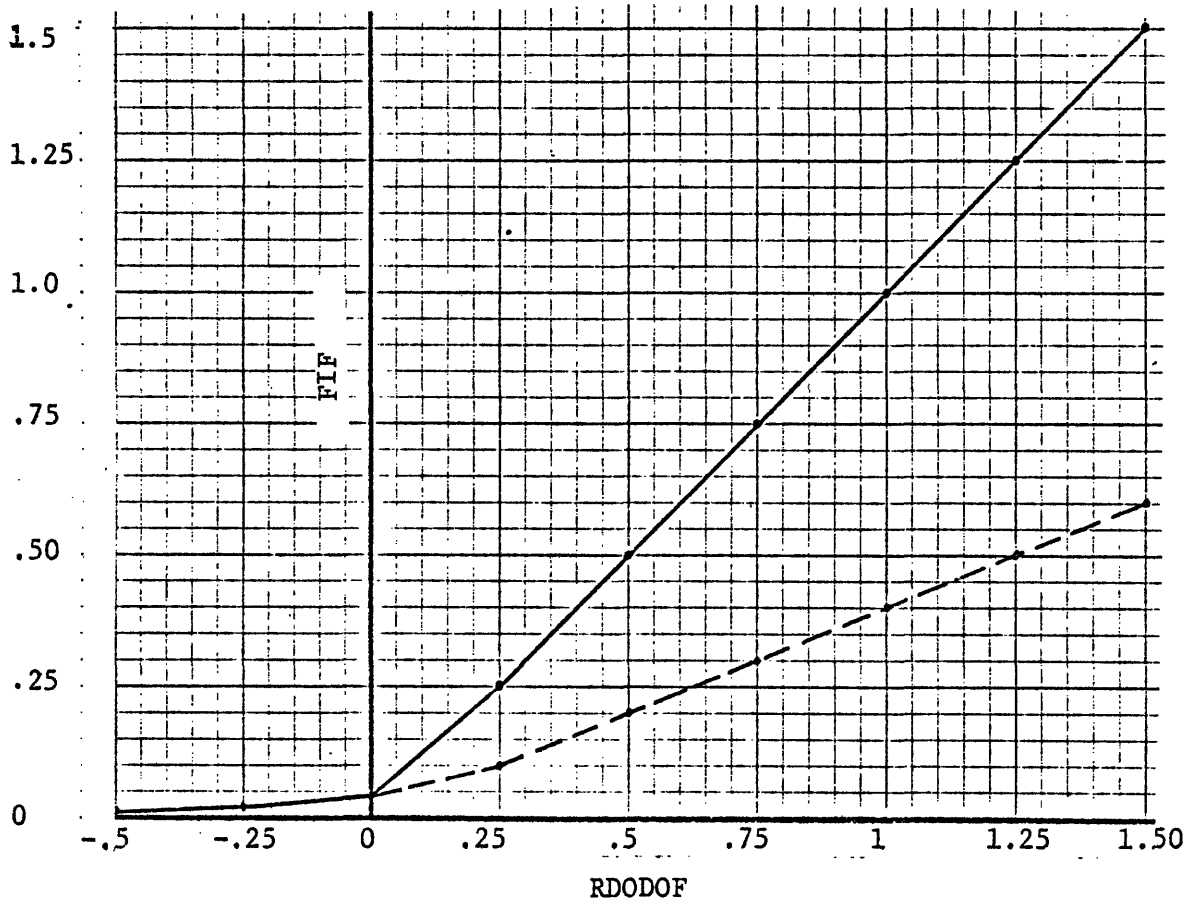

Figure 5.3: Fraction for Import of Food FIF Versus the Ratio of Demand Output Discrepancy to Food Output RDODOF.

the model after 1978, TFIC (a parameter in Equation 179) is changed from 1 to zero.

The new policy improves the behavior of the model although not dramatically. Figures 5.4a through 5.4d show the new behavior. In comparison with the BASIC run, non-oil output stagnates at a higher value after 1987; GNP and GNP per capita rise to higher maximum values in the late 1980's, drop not as low as they do in the BASIC run, and then recover and rise more rapidly after the mid-1990's; food per capita neither rises nor falls as much as it does in the BASIC run during the 1980's and 1990's. Although the new policy improves the performance of the model, it does not eliminate the crisis.

Restrictions on the importation of food encourage expansion of domestic agriculture. After 1978, imported food drops as shown in Figure 5.4d. As a result, total food and food per capita drop in 1979, shown in Figures 5.4b and 5.4a, respectively. Pressures to expand the agricultural sector rise. Food output, shown in Figure 5.4b, grows more rapidly than it does in the BASIC run, shown in Figure 4.1b. Growth of food output continues until 1993 when the domestic oil shortage decreases agricultural productivity and food output. Food output drops until the year 2000, when growth of production factors as well as improvements in agricultural technology raise food output.

Owing to restrictions on food imports and the growth of the agricultural sector, food output provides most of the total food consumer in the country after 1978. During the simulation after 1978, imported

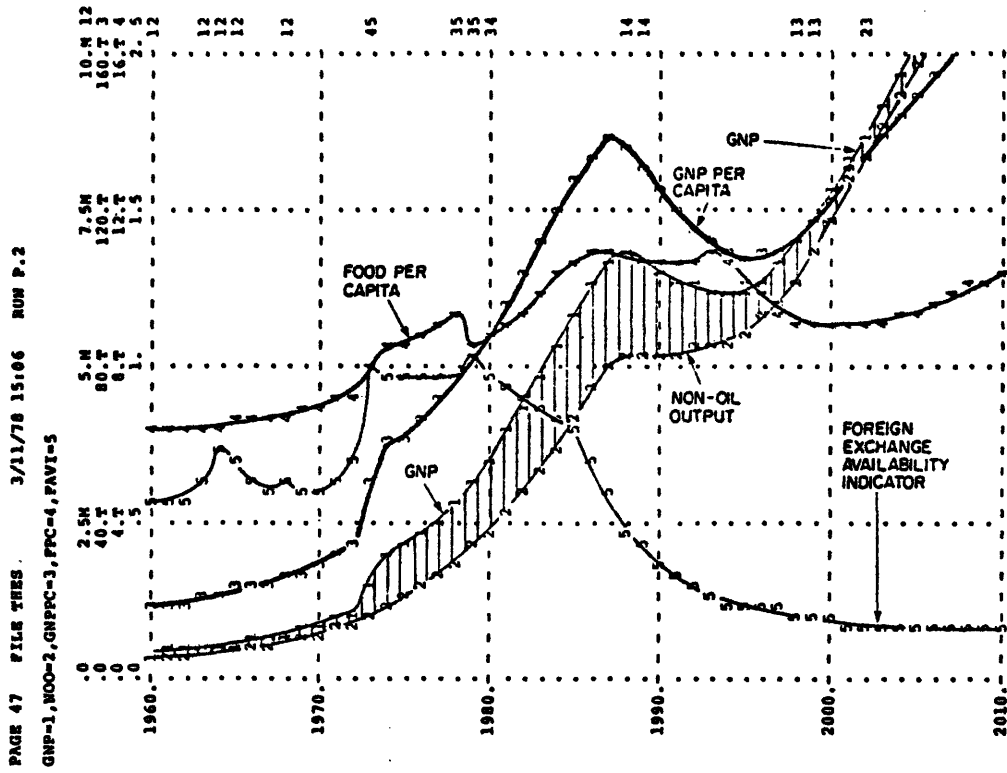

Figure 5.4 a

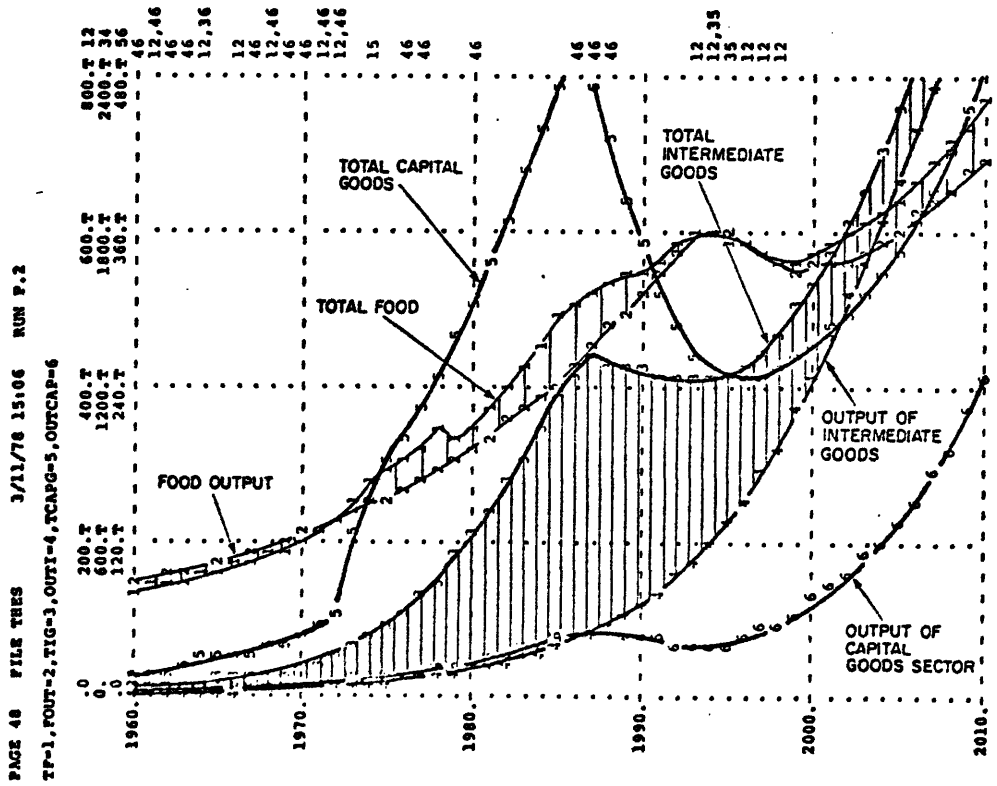

Figure 5.4 b

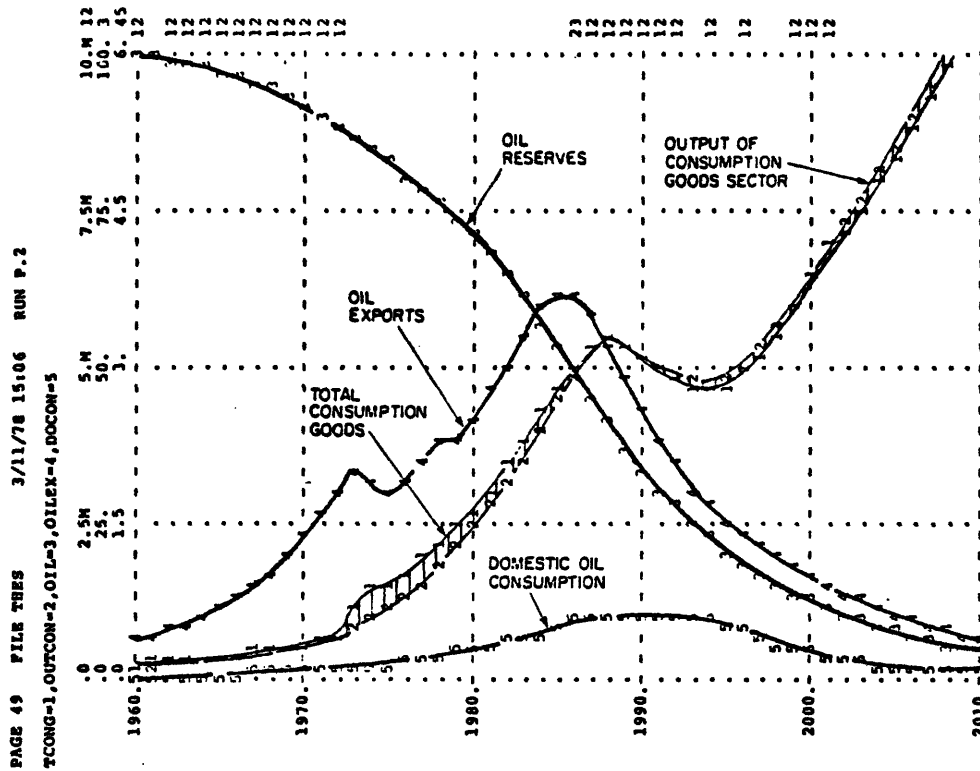

Figure 5.4 c

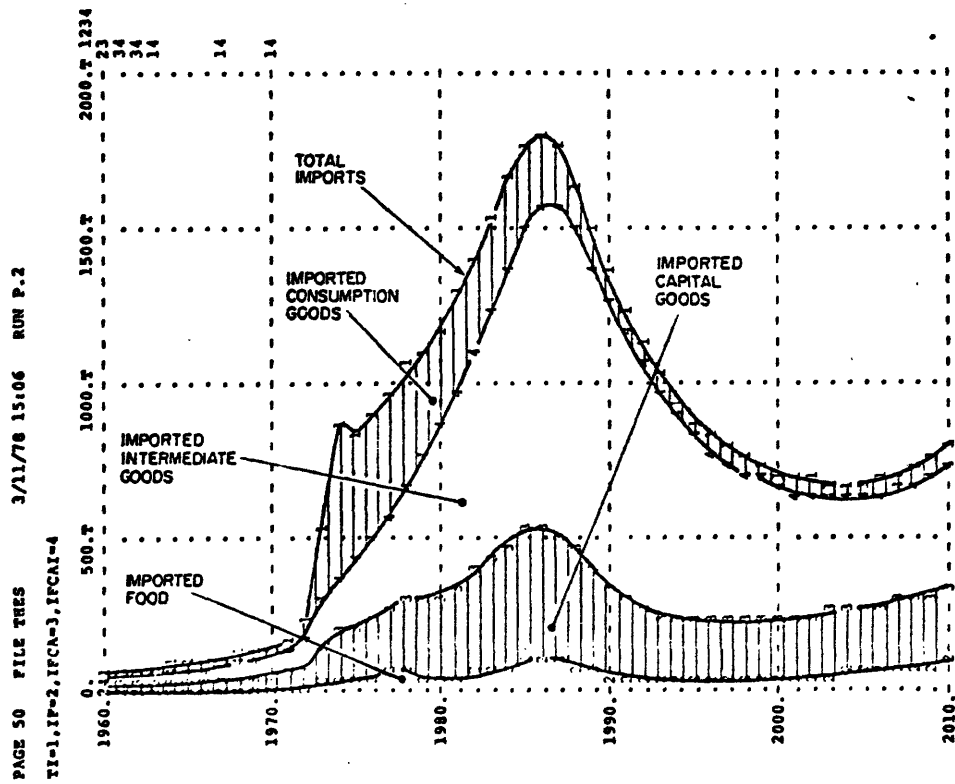

Figure 5.4 d

Figure 5.4: Behavior of the Model with Restrictions on the Importation of Food.

food is much lower in this run, shown in Figure 5.4d, than it is in the BASIC run, shown in Figure 4.1d; the excess of total food over domestic food output, in Figure 5.4b, is much less than the correspondent value in the BASIC run, shown in Figure 4.1b. The new policy reduces imported food and, therefore, the foreign exchange requirement to pay for food imports.

Reduction of foreign exchange requirements for food imports decreases oil exports relative to the BASIC run. As foreign exchange payment for food imports drops in 1979, foreign exchange availability rises, as shown in Figure 5.4a. Rising foreign exchange availability decreases pressures to expand oil exports. Oil exports do not rise in 1979. In comparison with the BASIC run, more of the oil reserves are remaining to be exported after the crisis, when foreign exchange revenues are badly needed.

In addition, as foreign exchange payment for food imports falls, available foreign exchange for importation of intermediate and capital goods rises relative to the BASIC run. In comparison with the BASIC run, imports of intermediate and capital goods are higher in this run; total intermediate and capital goods, shown in Figure 5.4b, rise to higher values and do not fall as much as they do in the BASIC run, shown in Figure 4.1b. A higher total intermediate goods allows non-oil output to grow and stagnate at a higher level in Figure 5.4a than it does in Figure 4.1a of the BASIC run. After 1986, higher values of non-oil output and oil revenues increase GNP and GNP per capita in this run above their

correspondent values in the BASIC run. However, the new policy does not eliminate the crisis. GNP, GNP per capita, and food per capita fall after the mid-1980's, although less dramatically than they do in the basic run. The next section examines another policy.

### 5.3 RESTRICTIONS ON GROWTH OF OIL EXPORTS

The last two sections showed that when, as a result of the new policies, some of the oil reserves were saved to be exported after the crisis, the behavior of the model was improved relative to the BASIC run. This section examines a new oil exports policy that restricts the growth of oil exports after 1977.

In the BASIC run, oil exports rise as rapidly as desired oil exports after 1977. Desired oil exports depend on average oil exports, the size of the oil reserves relative to production, and foreign exchange availability. When the reserves cover more than fifteen years of production or foreign exchange availability decreases, desired oil exports rises, and vice versa.

According to the new policy in this section, after 1977, oil exports grow as rapidly as desired oil exports as long as growth in each year is less than 2 per cent of average oil exports during the two previous years. Therefore, the new policy limits the growth of oil exports at about 1 per cent per year regardless of pressures from foreign exchange shortage. The new policy is adapted in the model by changing



the table function for multiplier for oil exports from desired exports in Equation 232.1 of Appendix A.

The new policy smoothes the transition significantly. Figures 5.5a through 5.5e show the new behavior. This section explains the new behavior in comparison with the behavior in the BASIC run. GNP and non-oil output grow continuously during the simulation. GNP per capita does not decline. Food per capita falls, but only slightly after 1996, for about 6 years, and then rises. Although GNP and food per capita do not rise as high as they do in the BASIC run during the 1980's, their values in Figure 5.5a after 1991 are continuously higher than in Figure 4.1a of the BASIC run.

Oil exports, shown in Figure 5.5c, grow very slowly under the new policy after 1978. In comparison with the BASIC run, from 1978 to 1991, oil exports are lower in this run. As a result, oil reserves do not deplete as fast as they do in the BASIC run during 1978 to 1991; reserves in 1991 are higher in this run. Although eventually reserve restriction decrease oil exports, oil exports remain continuously higher in this simulation relative to the BASIC one after 1991. As a result of the new policy, oil exports are spread more uniformly over a longer period of time. The new pattern of oil exports influences different aspects of economic performance during the simulation.

Because the new policy restricts growth of oil exports, high foreign exchange availability can not be retained by rising oil revenues. As the economy grows and desired imports of food, capital,

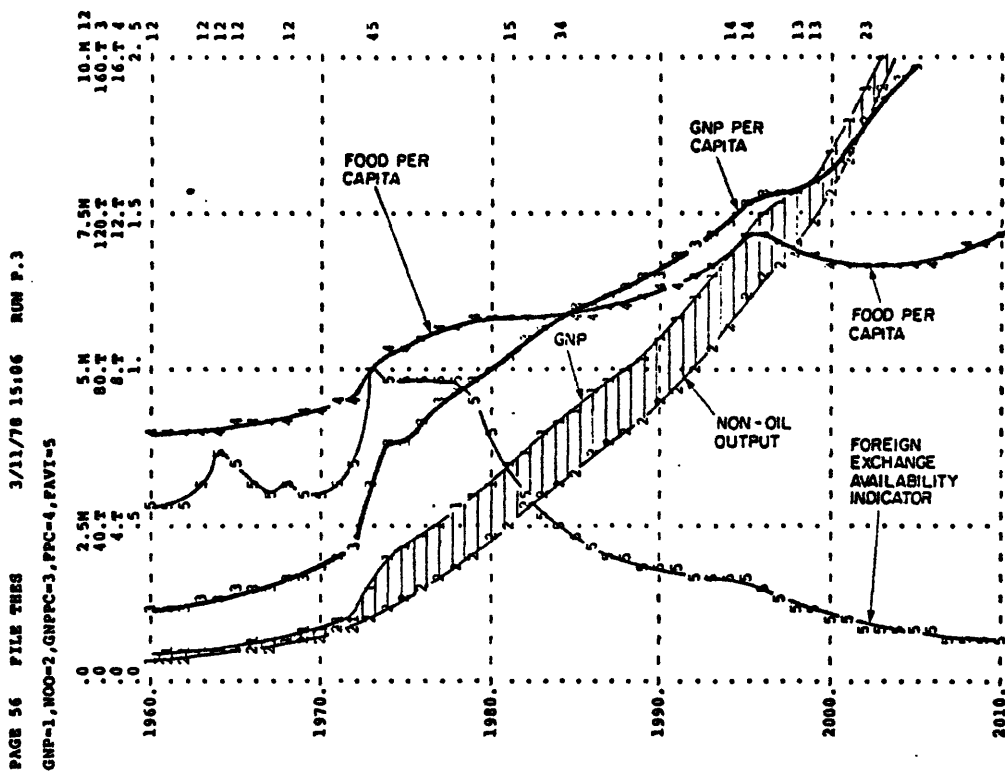

Figure 5.5 a

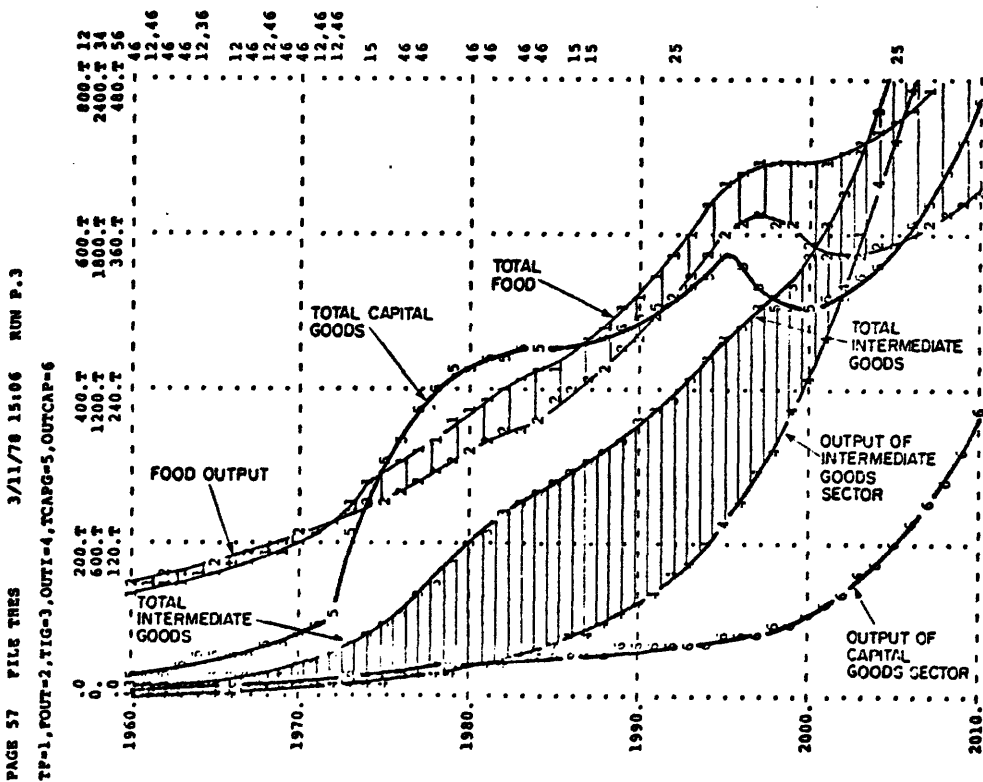

Figure 5.5 b

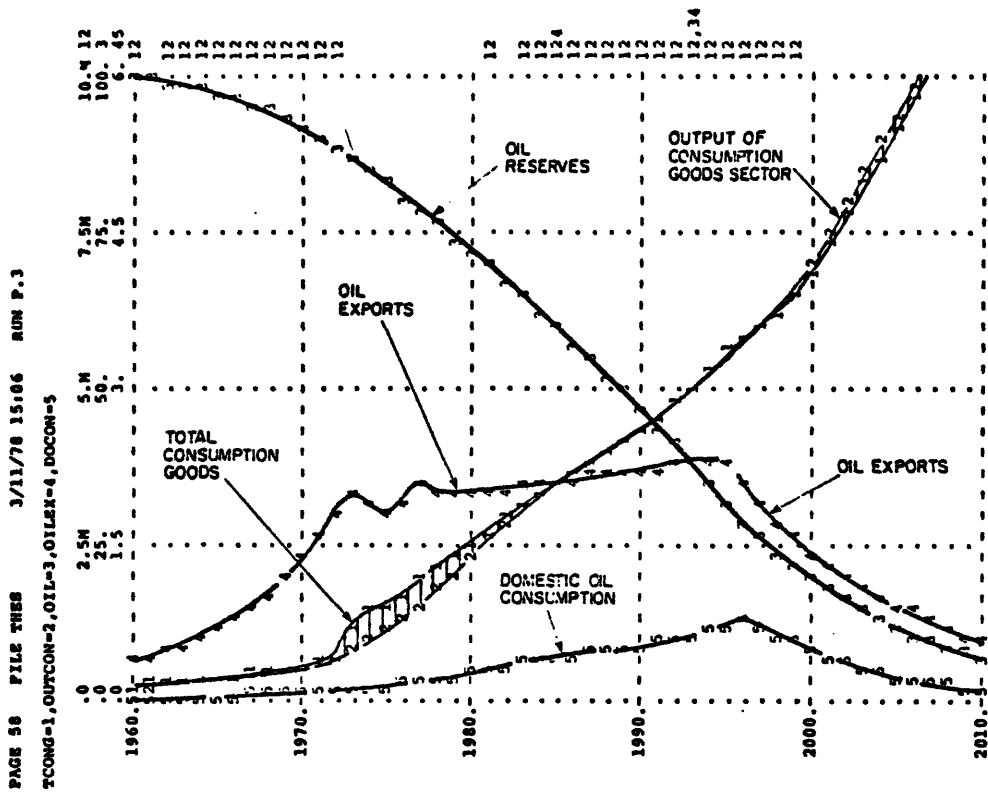

Figure 5.5 c

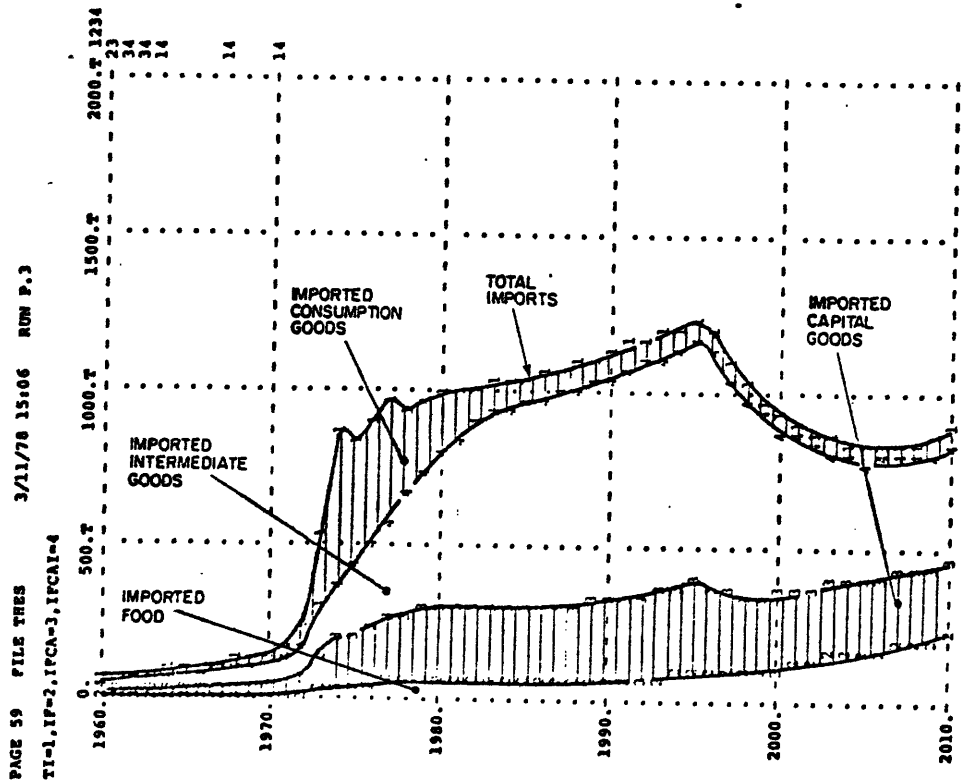

Figure 5.5 d

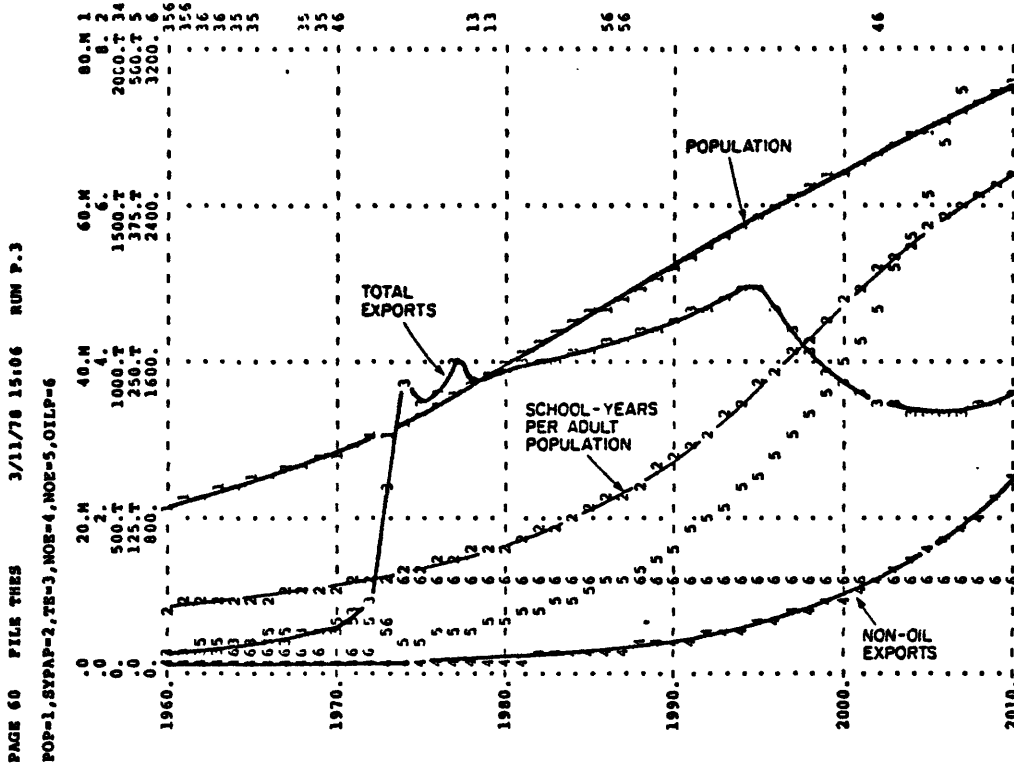

Figure 5.5 e

Figure 5.5: Behavior of the Model with Restrictions on the Growth of Oil Exports.

intermediate, and consumption goods rise, foreign exchange availability, shown in Figure 5.5a, falls. Low foreign exchange availability persists throughout the simulation, restricting the growth of total imports.

Total imports, shown in Figure 5.5d, rise slowly from 1978 to 1995, when the decline of oil exports, in Figure 5.5c, and foreign exchange income decrease total imports. Total imports neither rise nor fall as sharply as they do in the BASIC run. Total imports are lower during 1978-1991 and higher after 1991 in comparison with total imports in the BASIC run. The pattern of total imports is smoother in this run.

In the new pattern of imports, shown in Figure 5.5d, imports of consumption goods, including arms, decrease after 1978 both because pressures to import from aggregate demand are lower and because a foreign exchange shortage appears. Restriction of oil exports thus slows down the growth of GNP. As a result, the growth of aggregate demand for consumption goods, which rises with GNP, decreases. The excess of demand over domestic supply falls, lowering desired imports of consumption goods. In addition, low foreign exchange availability decreases actual consumption goods imports below the desired level. The decline of consumption goods imports allows the share of food, capital goods, and intermediate goods in total imports to rise.

But, in the new pattern of imports, food imports do not rise during the 1980's, as they do in the BASIC run. In this simulation, growth of agriculture and self-sufficiency in food is improved as shown by Figure 5.5b in comparison with Figure 4.1b of the BASIC run. The

improvement occurs due to changes in both the demand and supply sides of the agricultural products market. On the demand side, the new policy slows down the rapid growth of oil revenues and GNP after 1978; as a result, aggregate demand for food does not exceed domestic supply as much as it does in the BASIC run. Desired food imports lowers. However, because of low foreign exchange availability, total desired food can not be imported. Therefore, on the supply side, pressures to expand the agricultural sector rise. Growth of agriculture and food output, shown in Figure 5.5b, accelerates. Net food imports is lowered relative to the BASIC run. In Figure 5.5b, food output grows until 1997, when the decline in domestic oil consumption caused by depletion of reserves, shown in Figure 5.3c, decreases food output for a few years. But further growth of production resources and technology in the agricultural sector restores growth of food output.

Relative to the BASIC run, rapid growth of agriculture in this run is facilitated by a lower competition from the consumption goods sector for production resources during 1978 to 1992. Because of a lower growth of GNP after 1978 in this run, aggregate demand for consumption goods does not rise as rapidly as in the BASIC run. A lower growth of aggregate demand decreases pressures to expand the consumption goods sector. In addition, growth of the sector slows down after 1978, when adequate intermediate goods, used by the sector, can not be imported due to the foreign exchange constraint. As growth of the consumption goods

sector slows down relative to the BASIC run, more production resources become available for expansion of agriculture and other production sectors.

Although growth of the consumption goods sector slows down after 1978, as shown in figure 5.5c, the sector grows continuously during the simulation. Output of the consumption goods sector does not fall as it does in Figure 4.1c of the BASIC run. Relative to the BASIC run, output of the sector is lower from 1978 to 1992, but higher after 1992. The continuous growth of output of the consumption goods sector in this run is due to the continuous growth of total intermediate goods supply.

Figure 5.5b shows total intermediate goods, domestic intermediate goods output, and net imports of intermediate goods. In comparison with the BASIC run, total intermediate goods does not rise as rapidly, but it does not fall either. Net imports of intermediate goods, represented by the gap between total intermediate goods and domestic output, grows until 1995. After 1995, when oil revenues as well as total exports, shown in Figure 5.5e, fall, imports of intermediate goods also decline, as shown in Figure 5.5d. However, growth of domestic intermediate goods output compensates for the gradual decline of imports, and total intermediate goods continuously rises during the simulation.

A continuous growth of total intermediate goods generates a similar continuous growth in consumption goods and capital goods output, as shown in Figures 5.5c and 5.5b, respectively. As outputs of the

consumption, capital, and intermediate goods sectors grow smoothly, so does non-oil output in Figure 5.5a. A continuous growth of non-oil output and a gradual change in oil revenues result in a continuous growth of GNP during the simulation, as shown in Figure 5.5a

In summary, the new policy restricts growth of oil exports; oil reserves last longer; oil exports are spread more uniformly over a longer period relative to the BASIC run. Restrictions from foreign exchange revenues slow down the growth of imports. A foreign exchange shortage appears after 1978 and persists throughout the simulation. Food imports do not rise during the 1980's. Growth of agriculture and self-sufficiency in food improve relative to the BASIC run. Because the new policy improves the imports capability of the nation after 1990 relative to the BASIC run, the total supply of intermediate goods grows continuously in the simulation. Similarly, the growth of capital goods output, consumption goods output, non-oil output and GNP is continuous. The behavior of the model improved.

#### 5.4 A COMBINATION POLICY

This section examines the behavior of the model when the three policies discussed previously are adopted simultaneously. Restrictions on consumption goods imports and food imports improved the behavior of the model slightly. Restrictions on the growth of oil exports improved the behavior substantially. In a combination of three policies, each one might contribute to a better behavior. In order to implement the three



policies into the model, the values of TFIC, in Equation 179.1, and TCOIC, in Equation 193.1, are changed from one to zero, and the table function for multiplier for oil exports from desired exports, in Equation 232.1, is changed to level off at 1.02.

The new behavior, shown in Figures 5.6a through 5.6d, generates a smooth transition and is very similar to that of the previous section. Some small difference, however, exist between the behaviors in the two sections.

In this run, imports of food and consumption goods, shown in Figure 5.6d, fall after 1978 due to restrictions on imports. As a result, total food, shown in Figure 5.5b, and food per capita, shown in Figure 5.6a, drop after 1978. Pressures to expand agriculture rise. Growth of agriculture accelerates. Food output in Figure 5.5b rises more rapidly than it does in Figure 5.5b of the previous run. Food per capita, shown in Figure 5.6a, increases while almost all of total food, shown in Figure 5.6b, is supplied domestically; the country is quite self-sufficient in food. Food per capita, in Figure 5.6a, matches food per capita in the previous run in the early 1990's, but falls below it after 1999 when domestic food output decreases due to the decline in domestic oil consumption shown in Figure 5.6c. After 1999, food per capita in this run is lower than in the previous run because imports restrictions do not allow food imports to raise the total food as much as in Figure 5.5b of the last run.



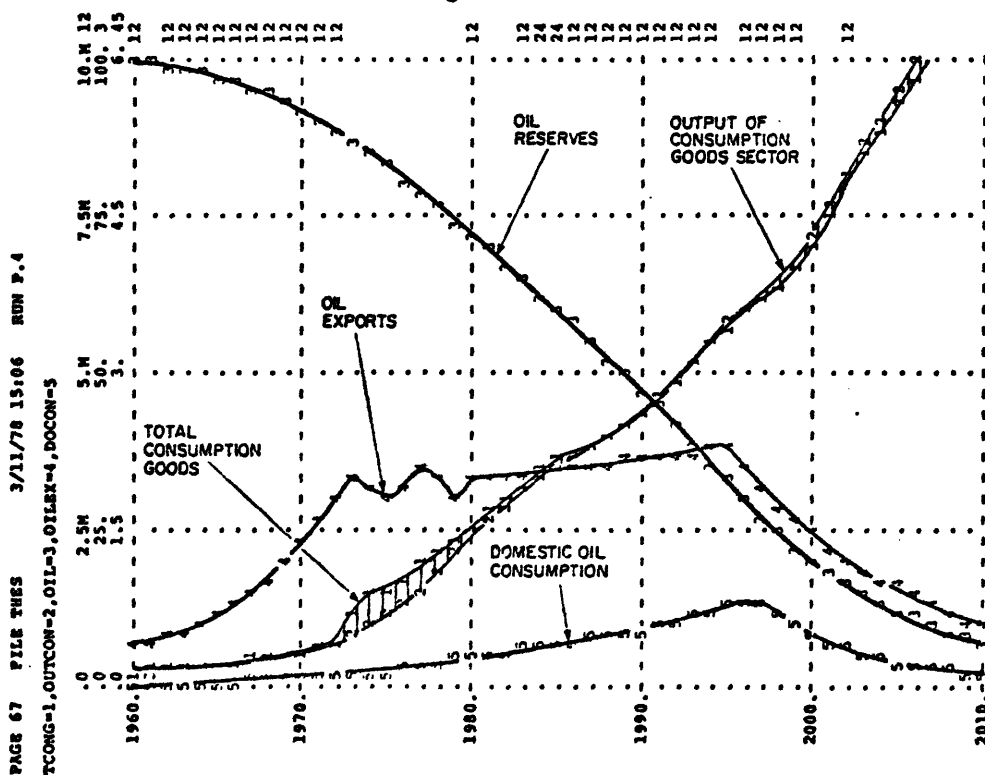

Figure 5.6 c

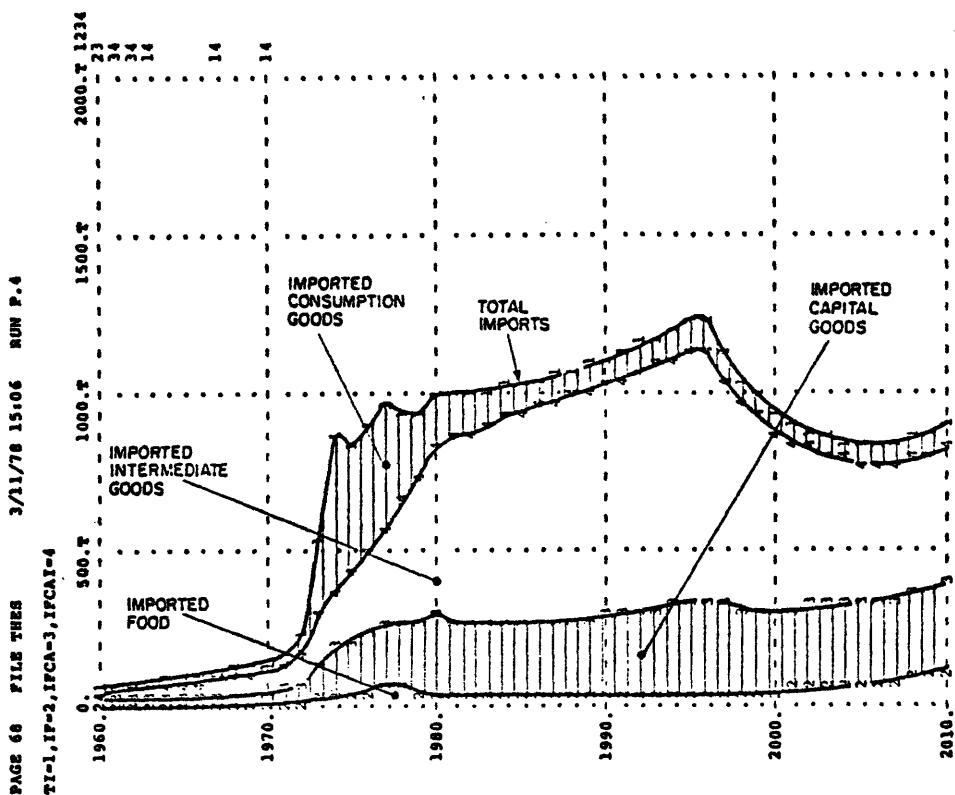

Figure 5.6 d

Figure 5.6: The Behavior of the Model with a Combination Policy: Restrictions on Consumption Goods Imports, Food Imports, and Growth of Oil Exports.

Drop in imports of food and consumption goods after 1978 permits Iran to increase, instead, imports of intermediate and capital goods. Imports of intermediate and capital goods, shown in Figure 5.5d, as well as total intermediate goods and total capital goods, shown in Figure 5.5b, are slightly higher than what they are in the previous run after 1978. A higher total intermediate goods allows a higher capacity utilization in the consumption and capital goods sectors in this run relative to the previous run. Relative to the last run, after 1978, output of consumption goods, shown in Figure 5.4c, and capital goods, shown in Figure 5.4b, are higher; as a result, non-oil output, GNP, and GNP per capita, all shown in Figure 5.4a, are slightly higher than what they are in the last run after 1978 throughout the simulation.

In summary, the three simultaneous policies, adopted in this section, smooth out the transition similarly to the previous run except for some small differences. Relative to the last run, food per capita is lower during most of the simulation period after 1978, but non-oil output, GNP, and GNP per capita are higher.

#### 5.5 A COMBINATION POLICY COUPLED TO AN ANNUAL 5 PER CENT RISE IN PRICE OF OIL

The previous section examined three simultaneous policies - restrictions on imports of food, consumption goods, and growth of oil exports - with a constant real price of oil after 1976. This section examines the effect of the same three policies when the price of oil is

assumed to rise at a rate of 5 per cent per year after 1980. In the model, in order to raise the price of oil after 1980, parameter TGIPO is changed from zero to one in Equation 241 of Appendix A.

Figures 5.7a through 5.7e show the new behavior of the model on the same scale which was used in all the previous simulations. Figure 5.7f shows GNP, non-oil output, and GNP per capita plotted on a scale twice as large as that in Figure 5.7a. Figure 5.7g shows total intermediate goods, intermediate goods output, total capital goods, and capital goods output, and is plotted on a scale that is twice as large as that in Figure 5.7b. The new behavior should be compared with the behavior in the last section, shown in Figures 5.6a through 5.6e, where the price of oil is kept constant after 1976. In the new behavior after 1980, GNP, non-oil output, and food per capita all grow more rapidly on the average and have higher values. In Figure 5.7f, GNP per capita falls slightly for three years after 1995 and then rises again. A gradual rise in the price of oil combined with the three policies results in a continuously higher income per capita without any major transition problem.

In this run, the pattern of oil exports, shown in Figure 5.7c, is quite similar to that of the previous run, shown in Figure 5.6c. However, after 1980, as oil price, shown in Figure 5.7e, increases, oil revenues grow more rapidly and have relatively higher values throughout the simulation. Growth of oil revenues and total exports, shown in Figure 5.7e, continue until 1994, when oil exports, shown in Figure 5.5c,

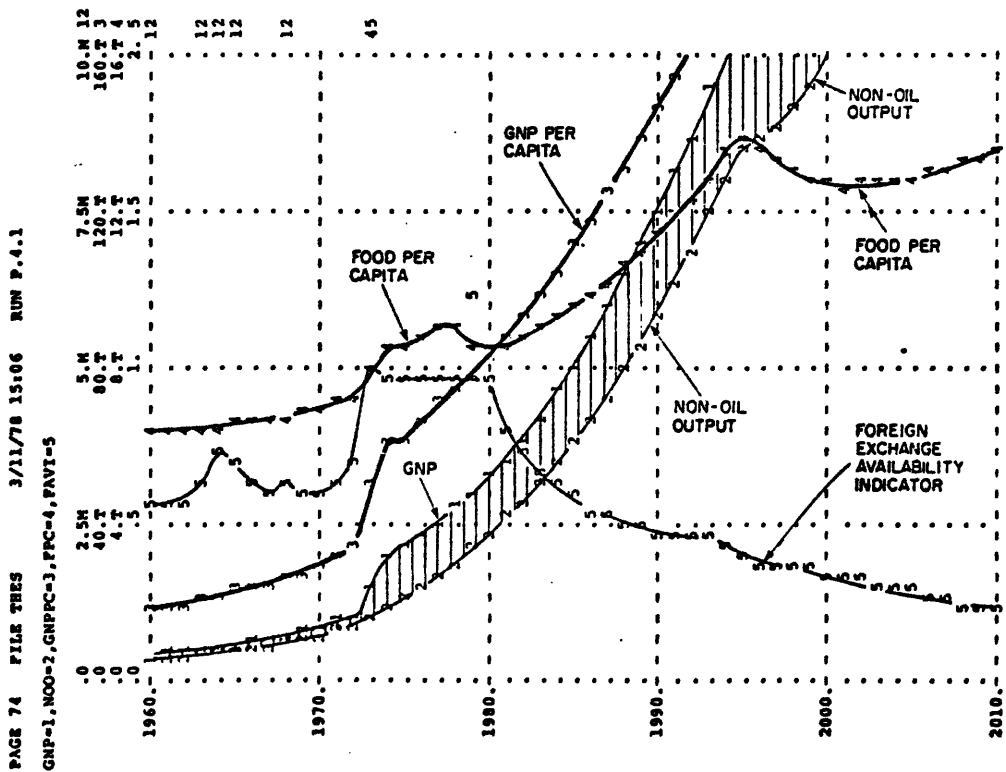

Figure 5.7 a

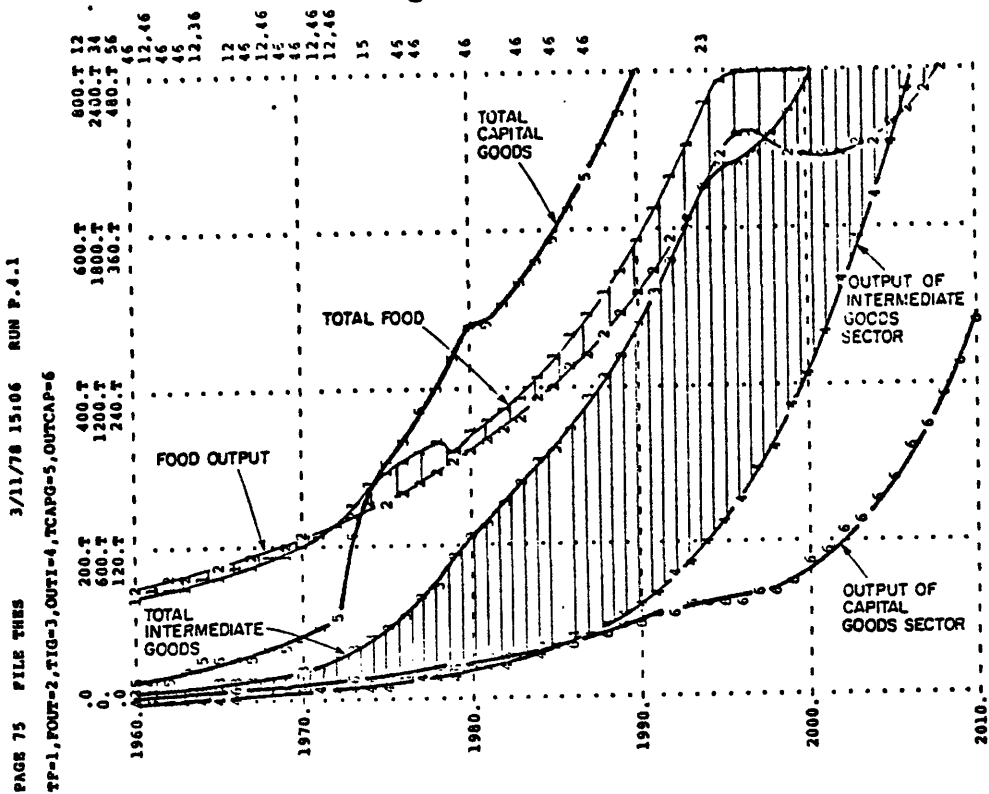

Figure 5.7 b



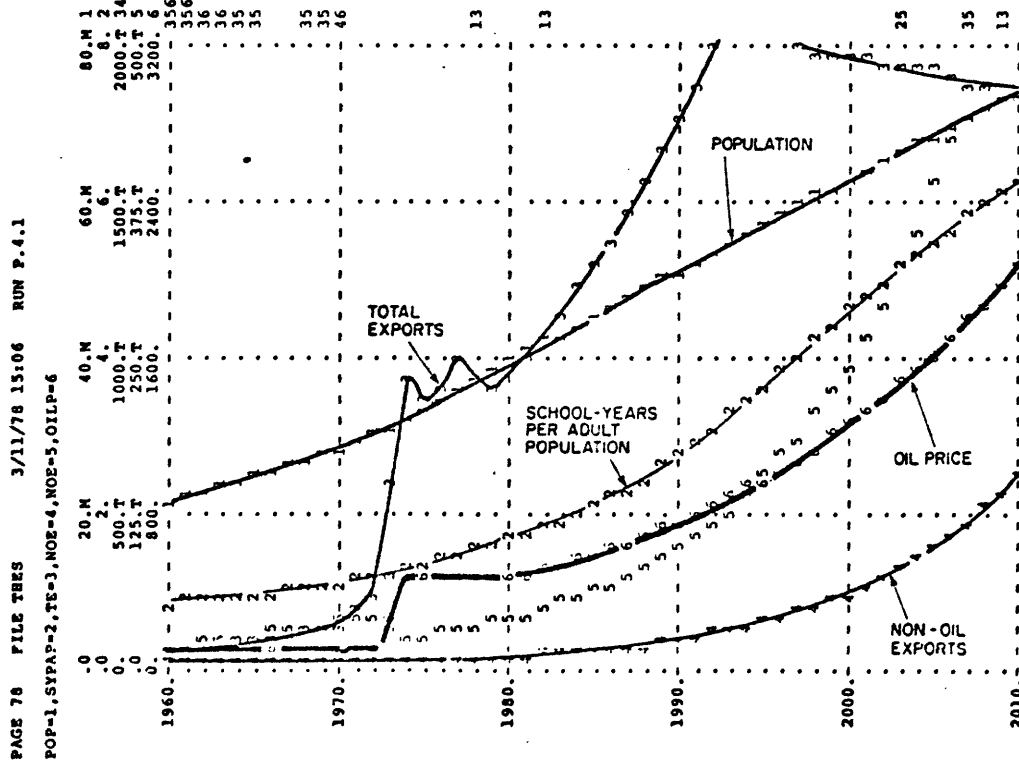

Figure 5.7 e

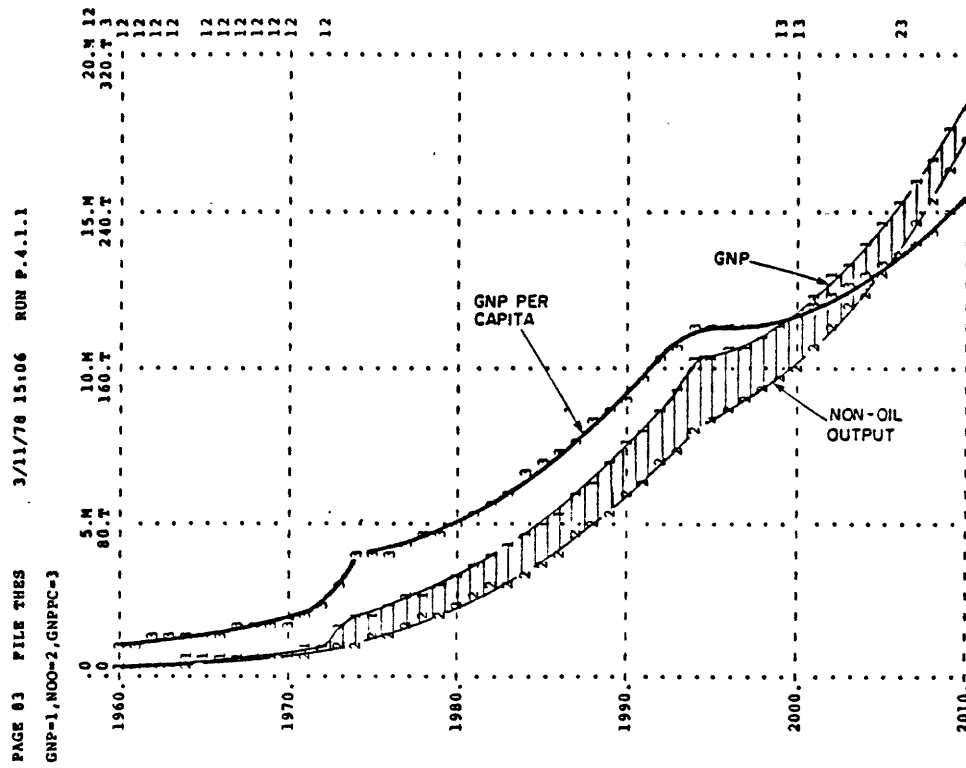

Figure 5.7 f



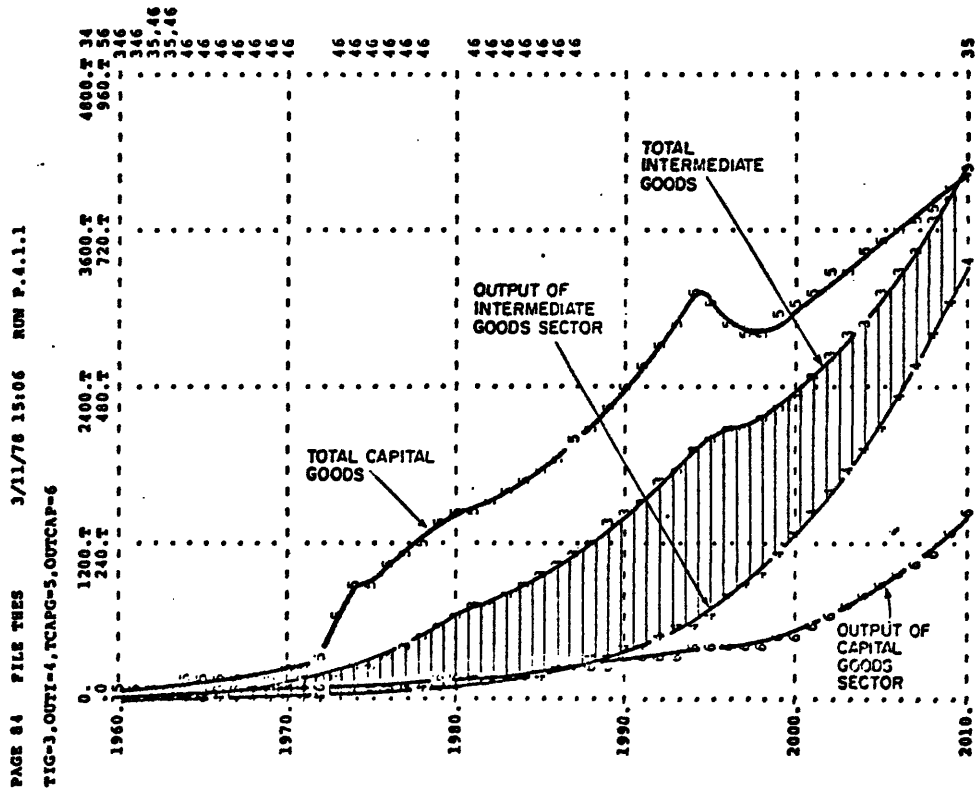

Figure 5.7 g

Figure 5.7: The Behavior of the Model with a Combination Policy Coupled to an Annual 5 Per Cent Rise in the Price of Oil.

decline due to reserve restrictions. But, oil revenues do not fall as rapidly as oil exports because the price of oil is continuously rising. And after 1994, total exports declines even more slowly than oil revenues because of the growth of non-oil exports.

Total exports determine the import capability of the economy. Figure 5.7d shows total imports and its composition during the simulation. Total imports reach a maximum, which exceeds the plotting scale used in Figure 5.7d, in 1995 at about twice the level of the maximum of total imports in Figure 5.6d of the last section. Imports of intermediate and capital goods constitute most of the imports during the simulation after 1980. Imports of food and consumption goods remain low relative to total imports due to imports restrictions on food and consumption goods.

Higher foreign trade activities and capital goods imports, in this run relative to the last one, accelerate the growth of production capacity. Higher trade activities increase the rate of technology transfer. Technology levels in industry and agriculture, not shown in the figures, grow more rapidly, resulting in a higher growth rate of production capacity in both sectors. In addition, higher capital goods imports increase total capital goods, shown in Figure 5.7b and Figure 5.7g with a doubled scale, invested in each year. As a result, capital stock and, therefore, production capacity in the economy, grow more rapidly, demanding more intermediate goods.

Until 1995, rapidly growing intermediate goods imports, shown in Figure 5.7d, and growth of domestic intermediate goods output, shown in Figure 5.7b, increase total intermediate goods more rapidly in Figure 5.7b than in Figure 5.6b of the previous run. After 1995, when intermediate goods imports decline growth of domestic output keeps total intermediate goods rising, as shown in Figure 5.7b. As a result, with a 5 per cent rise in the price of oil after 1980, total intermediate goods have a higher value than they do in the last run and grow continuously throughout the simulation.

During the simulation after 1980 in this run, more rapid growth of production capacity and total available intermediate goods result in more rapid growth of the consumption and capital goods sectors on the average. After 1980, output of consumption goods and capital goods, shown in Figures 5.7c and 5.7b, respectively, are higher than corresponding values in the previous run, shown in Figure 5.6c and 5.6b. As a result of higher output in the consumption and capital goods sectors, non-oil output in this run, shown in Figure 5.7a, grows more rapidly than it does in Figure 5.6a of the last section.

Because non-oil output and oil revenues grow, on the average, more rapidly, the sum of the two - i.e., GNP shown in Figure 5.7a - is continuously higher in this run than it is in figure 5.6a of the last run after 1980. A higher growth of GNP results in a higher growth rate of GNP per capita shown in Figure 5.7a.

Higher income per capita in this run increases the demand for food above that of the previous run. Pressures from demand for food both accelerate agricultural growth and increase food imports despite import restrictions on food. Food output, net food imports, and total food, shown in Figure 5.5b, all have higher values in this run, relative to the last run, after 1980.

In summary, in this simulation relative to the previous one, oil revenues and total exports grow more rapidly until 1995, when oil exports decline due to reserve restrictions. However, because oil prices keep rising, after 1995, neither oil revenues nor total exports decline as much as they did in the last run. Higher exports enable the country to import more. A higher level of foreign trade accelerates technology transfer and therefore growth of production capacity. In addition, because imports of food and consumer goods are restricted, most of the imports are capital and intermediate goods. Higher imports of capital goods, in this run, results in a higher growth of capital stock and, therefore, production capacity in the economy. Owing to higher imports of intermediate goods, the total supply of intermediate goods also grows more rapidly in this run. As a result of higher production capacity and higher supply of intermediate goods, after 1980, non-oil output is continuously higher in this run. Higher non-oil output and oil revenues after 1980 result in a higher GNP and GNP per capita. Because of higher income per capita, demand for food becomes higher. Pressures from food

demand accelerate the growth of agriculture and increase net food imports, resulting in a higher food per capita in this run during the simulation after 1980.



## CHAPTER 6

### SUMMARY, CONCLUSIONS AND FURTHER EXTENSION

This chapter summarizes the study and presents important conclusions. The chapter also points out some of the limitations of the model and suggests further extensions.

#### 6.1 SUMMARY AND CONCLUSIONS

Oil revenues give Iran a transitory opportunity for rapid economic growth and development. Oil revenues provide foreign exchange to import the necessary goods and services which will accelerate economic growth. The revenues increase GNP over non-oil output and stimulate aggregate demand for final goods - i.e, food, capital goods, and consumption goods and services.

Agricultural Output: As demand for food rises over domestic supply, either the discrepancy between demand and output should be imported, or price of food relative to other economic goods would rise. If food price rises, incentives to expand agriculture will increase, and growth of domestic food output accelerates. However, when foreign

exchange from oil is readily available, food importation seems an easier solution to inadequacy of domestic agricultural output. As food imports increase, total food supply rises, and incentives to expand domestic agriculture decrease. Then as GNP and demand for food grow further, so does desired food imports and foreign exchange requirements to pay for food imports.

Capital Goods: Economic growth requires investment in machinery, and desired investment in capital equipment increases as an economy grows. In Iran, most of capital equipment is currently imported; domestic production is for less than total supply. Growth of domestic capital goods sector requires accumulation of production resources as well as production experience in the sector. Both accumulations of resources and experience are time-consuming processes. Even with a strong imports substitution policy in the capital goods sector, Iran will have to import most of its necessary capital equipment during the next two to three decades. Therefore, for years to come, as the economy grows and demand for investment in capital equipment rises, desired imports of capital goods and foreign exchange requirements to pay for machinery imports rise.

Consumption Goods: As oil revenues increase demand for consumption goods and services over domestic supply, the discrepancy between the two can be imported as far as foreign exchange is available. However, although Iran is importing an enormous amount of arms and arms related services, the importation of conventional consumption goods is restricted to protect domestic producers. Stimulated demand and



protection against foreign producers make consumption goods industries attractive to entrepreneurs. Domestic production of consumption goods and services grows rapidly, attracting production resources from other sectors. Rapid growth of the consumption goods sector is based on growing imported intermediate goods financed by oil money which can not sustain forever.

Intermediate Goods: As capacity to produce consumption goods and services grow rapidly, so does demand for intermediate goods to feed the growing production activities. Intermediate goods are unfinished goods such as raw materials, steel sheets, parts of radios or TV sets or refrigerators, etc. which are used by producers of final goods. Currently, domestic production is far less than sufficient to satisfy the rapidly growing demand for intermediate goods - most intermediate goods are imported. Despite imports substitution and the growth of the domestic intermediate goods sector, net imports of intermediate goods will rise during the 1980's, demanding more foreign exchange and, therefore, oil revenues to pay for imports.

Horizontal Economic Expansion: Growth of net imports of intermediate goods is a result of horizontal economic expansion encouraged by oil revenues. Oil revenues, on one hand, increase GNP and, therefore, aggregate demand for final goods and services over domestic non-oil value added. Total non-oil value added represents non-oil production capacity of the country. Stimulated aggregate demand accelerates industrialization to satisfy demand for final goods and services. In order to satisfy stimulated demand for final consumer goods

and services domestically, the production capacity has to be allocated horizontally. A horizontal allocation of production capacity implies that the ratio of total value added to the total value of output in non-oil sector is below one; a horizontal allocation means that the production capacity of the country is mostly allocated to assembling production activities; a horizontal allocation means that the economy imports unfinished goods to produce final ones (in the case of Iran) for domestic demand stimulated by oil revenues.

Oil revenues, on the other hand, provide the necessary foreign exchange to pay for imports of intermediate goods. As the economy expands horizontally, desired imports of intermediate goods rise, raising required foreign exchange revenues. Oil exports may rise to satisfy foreign exchange needs as the economy expands horizontally.

Increasing Dependency on Oil: As desired food imports increases, as desired capital goods imports increases, and as the economy expands horizontally, raising desired imports of intermediate goods, so does the necessary foreign exchange revenues to pay for imports. Exports should increase to provide foreign exchange requirements. But expansion of non-oil exports is slow and difficult because it requires competition in international markets and exports experience. In addition, when oil revenues stimulate domestic demand, producers can sell all their products domestically. Therefore, incentives to expand exports are low. Thus, pressures rise to increase oil exports, for which a growing international demand exists. As long as no reserves restrictions on oil exports exist, oil exports may increase, raising the dependency of the economy on oil

revenues. Economic dependence on oil revenues has been increasing historically as shown in Chapter 1.

Oil Exports Policy Critical to the Transition: Historically, oil exports have been responsive to pressures from foreign exchange requirements. Oil exports have been raised to retain a normal foreign exchange availability and to accelerate economic growth. As a result, dependency of the economy on oil exports has been rising and, in turn, desired oil exports to support a growing oil-dependent economy has been growing. When oil exports grow, depletion of oil reserves accelerates, and reserves coverage of oil exports falls rapidly. In the past, responsiveness of oil exports to pressures from foreign exchange requirements could have been continued because the size of reserves relative to production has been large; the ratio of reserves to annual production has been well above 30 years.

However, if oil exports continue to rise in response to pressures from foreign exchange availability, this study suggests that Iran will face an economic crisis beginning in the late 1980's when reserves restrictions enforce a rapid reduction of oil exports. In such a crisis, discussed in Chapter 4, oil revenues fall rapidly; desired food, intermediate goods, and capital goods can not be imported; total available food decreases; capacity utilization in the economy falls and a part of production capacity of the nation becomes idle due to intermediate goods shortage; non-oil output drops or at best stagnates; GNP falls; while GNP and total food drop, growth of population results in a more drastic decline in GNP per capita and food per capita.

This thesis shows that oil exports policy is a key policy to prevent the crisis and to manage a smooth transition into an oil-independent era. The analysis in Chapter 5 suggests that for a smooth transition, Iran should strictly limit the growth of oil exports and, at the same time, encourage imports substitution in the intermediate and capital goods sectors. In Chapter 5, when a new policy limits growth of oil exports at one percent per year, the crisis almost disappears and the transition smooths out considerably. With the new policy, GNP will not rise as high as it will with the historical oil exports policy during the 1980's, but growth of GNP will be continuous and its value will be higher after 1991. The new oil exports policy (1) stops growing dependency of the economy on oil revenues, and (2) lengthens the life of reserves and, therefore, provides more time for the economic structure to adjust for an oil-independent era.

Implementation of the new oil exports policy might be difficult. Desire to import arms, and a growing demand for imports of intermediate goods, capital goods and food, generate pressures to raise oil exports. But, response to these pressures would lead to a crisis which will not be far away.

Self-Sufficiency in Food and Restrictions on Food Imports: The new oil exports policy will accelerate growth of agriculture and improve self-sufficiency in food. When the new policy limits growth of oil exports, oil revenues do not rise rapidly to finance growing imports. Foreign exchange shortage limits expansion of food imports. Pressures to expand the agricultural sector rise; growth of agriculture accelerates;

net food imports lowers, and self-sufficiency in food improves.

However, Section 5.3 suggests that the new oil exports policy does not eliminate dependency on food imports. Net food imports remains positive throughout simulation after 1971. In order to increase self-sufficiency in food, in addition to the new oil exports policy, some restrictions were imposed on food imports after 1978 in Section 5.4. As a result, total food and food per capita drop and remain slightly lower than what they are without imports restrictions. Instead, relative to the simulation without import restrictions, growth of agriculture accelerates and domestic output almost supplies total food consumption. Also as a result of the new policy, non-oil output, GNP and GNP per capital grow faster because the country can import capital and intermediate goods instead of reducing food imports.

Restrictions on Arms Imports: With the new oil exports policy in the model, a foreign exchange shortage appears in the early 1980's. Because oil revenues do not rise in response to pressures from foreign exchange requirements, arms and consumption goods imports should compete with other imports - i.e., food, intermediate, and capital goods - for available foreign exchange. As a result, unless arms imports receive a higher priority than capital and intermediate goods imports which are necessary for the growth and operation of the economy, imports of arms and consumption goods have to be reduced after 1978. Therefore, with the new oil exports policy, restriction on imports of consumption goods and arms have only a marginal effect on the model behavior shown in Section 5.4. However, in practice, restrictions on arms imports after 1978 can

decrease contracts and commitments for future purchases and, therefore, adoption of the new oil exports policy becomes easier.

Price of Oil: Price of oil is exogenous to this study. In the discussion of the crisis and policy analysis, the main assumption about oil price was that real price of oil will remain constant after 1976. However, alternative assumptions about oil price were examined in Chapters 4 and 5. In Chapter 4, real price of oil was assumed (1) to rise 100 percent in 1985 and (2) to grow 5 percent per year after 1980. None of the assumptions could eliminate the crisis although the second assumption improved the behavior to some extent. However, a 5 percent annual growth in real price of oil improves the behavior of the model substantially when simulated in Chapter 5 simultaneously with the three new policies - i.e., restrictions on growth of oil exports, foods imports, and consumption goods imports. While the new policies restrict expansion of oil exports and lengthen the life of reserves, growth of oil price increases the value of remaining reserves as well as oil revenues. And when oil imports decline due to reserves restrictions, oil revenues do not fall as rapidly as oil exports because price of oil increases. As discussed in Chapter 5, the new pattern of oil revenues would result in a higher income per capita for the nation without any major transition problem.

## 6.2 FURTHER EXTENSIONS

This thesis undertook an analysis of a very broad but important problem that Iran could face in the transition to an oil-independent

era. The study is one step in extensive research activities required to analyze and plan the transition period. In order to bring the analysis within the scope of a thesis, many simplifying assumptions were made. Chapter 3 and Appendix A explain all the assumptions underlying the study. This study may be extended for two interrelated purposes: first, to increase the level of confidence in conclusions of this study, and second, to analyze new issues and questions in relation to the transition. For both purposes, important assumptions in the study should be examined and possibly reformulated. This section suggests some directions for further extension.

Transition in Government's Revenues: The government receives oil revenues and spends them through development and operational budgets to finance government's services. As oil revenues rise, so do education, health, defense, and all other government's activities financed by oil money. However, when oil revenues decline, financial basis of the government's expenditures should be transformed to taxes and/or government's activities should be cut. During such a transition, government's employment might fall, raising overall unemployment; government's influence on economic activities could decline, decreasing its ability to manage the national economy; and, government's debts may rise, increasing inflation. All of these changes related to the transition of financial basis of the government would influence the overall economic transition into an oil-independent era. Because in this study, government is aggregated in other production sectors, the above issues can not be analyzed. A useful extension of this study could

disaggregate government from other production sectors. Such extension could increase our ability to manage the transition and to analyze the problems which government might face during the transition.

Investment: Demand for investment goods is assumed to be a fraction of GNP. For the sake of simplicity, the fraction is set as a function of GNP per capita and independent of aggregate demand relative to supply. However, in the real world, investment depends on demand for output relative to production capacity as well as available savings. Therefore, if Iran faces an economic crisis or a long recession during the transition, demand for output would decline, and as a result, investment would fall much more than what the present formulation in the model suggests. Drop in investment would decrease aggregate demand, worsening the economic crisis. Thus, further extension of investment function would contribute to a better understanding and management of the transition.

Unemployment: All labor force is assumed to be always fully employed in the model. Therefore, neither unemployment problem nor its effects on total output and/or aggregate demand are considered in this study. However, during the transition, one major problem that Iran might face is high unemployment. When the economy stagnates, unemployment could rise rapidly because population is growing. As unemployment increases, social stress rises, economic output falls, and aggregate demand declines. High unemployment and associated problems with it are all undesirable. Therefore, a useful extension of the model is reformulation of labor movement in order to capture changes in



unemployment. With such an extension, it should be possible to analyze the management of unemployment during the transition.

Natural Gas and Petrochemical: Iran has huge reserves of gas estimated to be around 500 trillion ( $10^{12}$ ) cubic feet (see Gas and Oil Journal, December 26, 1976). But Iran's reserves are located far from consumers in industrial nations. Liquidification and transportation of gas are expensive processes. Expense and difficulty of transportation limit potential exports of gas as a source of energy. So far, in Iran, most associated gas produced with oil has been flared. However, natural gas can still contribute substantially to the future foreign exchange revenues and domestic supply of energy. Natural gas may be exported directly or indirectly through exports of petrochemical products which are based on natural gas as feed stock. In the model, in order to account for the contribution of natural gas and petrochemicals to foreign exchange revenues, oil reserves were assumed to be larger than proven reserves and possible growth of non-oil exports was optimistically assumed to be 10 per cent per year in real terms over the long period of simulation. However, a more detailed analysis of the contribution of natural gas to development in Iran is helpful to increase the level of confidence in the results of this study. Therefore, formulation of the petrochemical industry as a production sector and natural gas reserves as a separate source of domestic energy, exports, and feed stock to the petrochemical industry is another useful extension of the model.



APPENDIX A: EQUATIONS DESCRIPTION

This appendix describes the equations of the model which are written in DYNAMO. For DYNAMO language see Pugh (1976). The model's equations quantify and present the exact form of the relationships described in Chapter 3. Chapter 3 explained the theoretical and logical foundation of the relationships underlying the structure of the system. This Appendix should be read in conjunction with Chapter 3. The arguments and explanations, as well as the DYNAMO flow diagrams, provided in Chapter 3 are very useful in relation to this Appendix.

A.1. ALLOCATION OF PRODUCTION FACTORS BETWEEN AGRICULTURAL AND INDUSTRIAL SECTORS

A.1.1. Allocation of Labor.

Labor, like capital and education, which are the other two production factors in the model, is allocated between agricultural and industrial sectors. Labor in agricultural sector LAS, Equation 3, is the fraction of labor in agriculture FLA times total labor L.

$$LAS.K = FLA.K * L.K \quad 3, A$$

LAS - LABOR IN AGRICULTURAL SECTOR (PERSONS)  
FLA - FRACTION OF LABOR IN AGRICULTURE  
(DIMENSIONLESS)  
L - LABOR FORCE (PERSONS)

Labor in industrial sector LIS, Equation 4, is the remaining labor out of the agricultural sector.

$$LIS.K = (1 - FLA.K) * L.K \quad 4, A$$

LIS - LABOR IN INDUSTRIAL SECTOR (PERSONS)  
FLA - FRACTION OF LABOR IN AGRICULTURE  
(DIMENSIONLESS)  
L - LABOR FORCE (PERSONS)

Fraction of labor in agriculture FLA, Equation 5, is the average desired labor in agricultural sector ADLAS divided by the sum of the average desired labor in agricultural sector ADLAS and average desired labor in industrial sector ADLIS.

$$FLA.K = ADLAS.K / (ADLAS.K + ADLIS.K) \quad 5, A$$

FLA - FRACTION OF LABOR IN AGRICULTURE  
(DIMENSIONLESS)  
ADLAS - AVERAGE DESIRED LABOR IN AGRICULTURAL  
SECTOR (PERSONS)  
ADLIS - AVERAGE DESIRED LABOR IN INDUSTRIAL SECTOR  
(PERSONS)

Average desired labor in agricultural sector ADLAS, Equation 6, is a smoothed value of desired labor in agricultural sector DLAS. The initial value of ADLAS is equal to the average desired labor in agricultural sector initial ADLASN. ADLASN is set equal to the number of labor in agriculture in 1959 - i.e., 3,417,000 workers. The time constant of the smoothing process is time to adjust labor TAL, which is taken as 15 years. TAL represents the delays involved in the movement of labor from one sector to another in response to the changes in the desired labor in the sector. TAL includes the time involved in the

perception of the changes in the desired labor in each sector by employers or planners, the generation of new employment opportunities and changes in wages, perception of employment opportunities and new wages by workers, preparation of facilities to accommodate the migrants to the more attractive sectors, and decisions by migrants to leave their familiar environments and move from rural to urban areas or vice versa.

ADLAS.K=ADLAS.J+DT*((DLAS.J-ADLAS.J)/TAL)	6, L
ADLAS=ADLASN	6.1, N
ADLASN=3417000	6.2, C
TAL=15	6.3, C

ADLAS - AVERAGE DESIRED LABOR IN AGRICULTURAL SECTOR (PERSONS)  
DLAS - DESIRED LABOR IN AGRICULTURAL SECTOR (PERSONS)  
TAL - TIME TO ADJUST LABOR (YEARS)  
ADLASN - AVERAGE DESIRED LABOR IN AGRICULTURAL SECTOR INITIAL (PERSONS)

Average desired labor in industrial sector ADLIS, Equation 7, is a smoothed value of desired labor in industrial sector DLIS. The initial value of ADLIS is equal to the average desired labor in industrial sector initial ADLISN which is set equal to the number of labor in the non-agricultural sectors in 1959 - i.e., 3,158,000 workers. The time constant of the smoothing process is time to adjust labor TAL.

ADLIS.K=ADLIS.J+DT*((DLIS.J-ADLIS.J)/TAL)	7, L
ADLIS=ADLISN	7.1, N
ADLISN=3158000	7.2, C

ADLIS - AVERAGE DESIRED LABOR IN INDUSTRIAL SECTOR (PERSONS)  
DLIS - DESIRED LABOR IN INDUSTRIAL SECTOR (PERSONS)  
TAL - TIME TO ADJUST LABOR (YEARS)  
ADLISN - AVERAGE DESIRED LABOR IN INDUSTRIAL SECTOR INITIAL (PERSONS)

Desired labor in agricultural sector DLAS, Equation 8, is equal to multiplier for labor in agricultural sector MLAS times labor in agricultural sector LAS. In the same way, desired labor in industrial sector DLIS, Equation 9, is the multiplier for labor in industrial sector MLIS times labor in industrial sector LIS.

$$DLAS.K = MLAS.K * LAS.K \quad 8, A$$

DLAS - DESIRED LABOR IN AGRICULTURAL SECTOR  
(PERSONS)

MLAS - MULTIPLIER FOR LABOR IN AGRICULTURAL SECTOR  
(DIMENSIONLESS)

LAS - LABOR IN AGRICULTURAL SECTOR (PERSONS)

$$DLIS.K = MLIS.K * LIS.K \quad 9, A$$

DLIS - DESIRED LABOR IN INDUSTRIAL SECTOR  
(PERSONS)

MLIS - MULTIPLIER FOR LABOR IN INDUSTRIAL SECTOR  
(DIMENSIONLESS)

LIS - LABOR IN INDUSTRIAL SECTOR (PERSONS)

The multiplier for labor in agricultural sector MLAS, Equation 10, is a function of utility of labor ratio in agriculture ULRA. Figure A.1 shows the functional relationship between MLAS and ULRA. When the utility of labor ratio in agriculture ULRA is one, indicating that the utility derived from one more labor in agriculture is equal to the average utility derived from one more labor in the economy, MLAS is also one. A value of one for MLAS indicates that the existing allocation of labor is efficient and the movement of labor from one sector to another is not necessary. When ULR is zero, indicating that the utility derived from labor in agriculture is zero, there is no reason to allocate labor to the agricultural sector. Therefore, for a zero value of ULRA, the

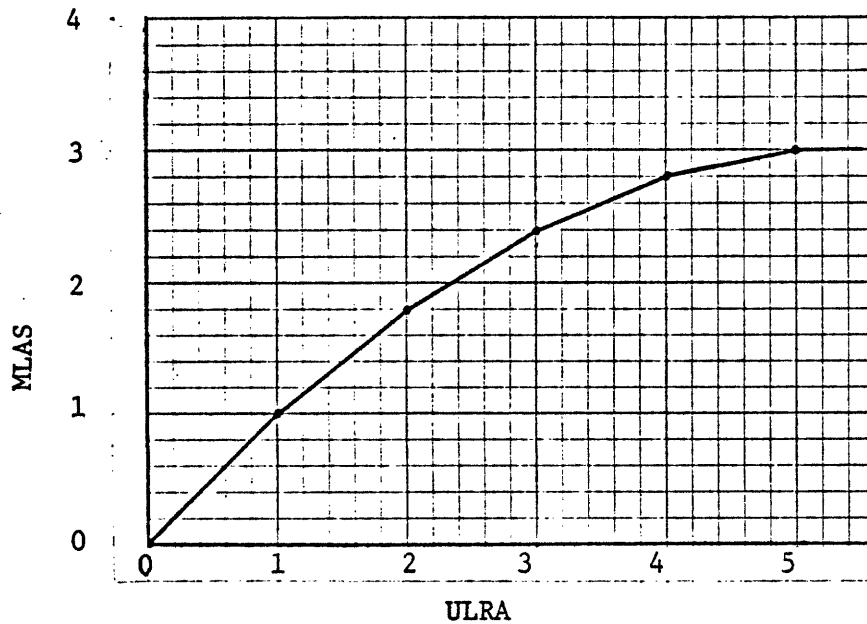

Figure A.1: Multiplier for Labor in Agricultural Sector Versus Utility of Labor Ratio in Agriculture

```
MLAS.K=TABHL(TMLAS,ULRA.K,0,5,1)                                10, A
TMLAS=0/1/1.8/2.4/2.8/3.0                                       10.1, T
  MLAS    - MULTIPLIER FOR LABOR IN AGRICULTURAL SECTOR
             (DIMENSIONLESS)
  TMLAS   - TABLE FOR MULTIPLIER FOR LABOR IN
             AGRICULTURAL SECTOR
  ULRA    - UTILITY OF LABOR RATIO IN AGRICULTURE
             (DIMENSIONLESS)
```

multiplier for labor in agricultural sector MLAS is set equal to zero and, as a result, desired labor in agricultural sector DLAS, according to Equation 8, becomes zero. As ULRA increases above 1, so does MLAS, with a decreasing slope. MLAS levels off at 3 when ULRA becomes more than 5. The decreasing slope of MLAS is based on the assumption that the response of different groups of people - workers, employers, planners - to any successive incremental rise in ULRA diminishes. People are reluctant to

deviate too much from normal economic life. The greater the necessary change - induced by a larger ULRA and indicated by a greater MLAS - is from normal practice, the harder it will be to push for further changes.

Multiplier for labor in industrial sector MLIS, Equation 11, is a function of utility of labor ratio in industry ULRI. Figure A.2 shows the functional relationship between MPLIS and ULRI, which is the same as the relationship between MPLAS and ULRA.

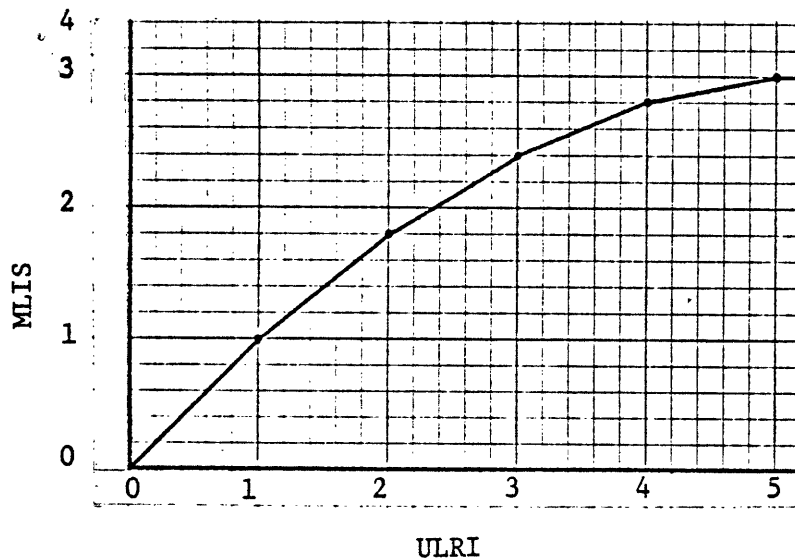

Figure A.2: Multiplier for Labor in Industrial Sector Versus Utility of Labor Ratio in Industry.

```
MLIS.K=TABHL(TMLIS,ULRI.K,0,5,1)           11, A
TMLIS=0/1/1.8/2.4/2.8/3.0                 11.1, T
MLIS   - MULTIPLIER FOR LABOR IN INDUSTRIAL SECTOR
         (DIMENSIONLESS)
TMLIS  - TABLE FOR MULTIPLIER FOR LABOR IN
         INDUSTRIAL SECTOR
ULRI   - UTILITY OF LABOR RATIO IN INDUSTRY
         (DIMENSIONLESS)
```



Utility of labor ratio in agriculture ULRA, Equation 12, is the marginal utility of labor in agricultural sector MULAS divided by the average marginal utility of labor AMUL.

$$\text{ULRA.K} = \text{MULAS.K} / \text{AMUL.K} \quad 12, A$$

ULRA - UTILITY OF LABOR RATIO IN AGRICULTURE  
(DIMENSIONLESS)  
MULAS - MARGINAL UTILITY OF LABOR IN AGRICULTURAL  
SECTOR (UTILITY/PERSON)  
AMUL - AVERAGE MARGINAL UTILITY OF LABOR (UTILITY/  
LABOR)

In the same way, utility of labor ratio in industrial sector ULRI, Equation 13, is the ratio of marginal utility of labor in industrial sector MULIS and average marginal utility of labor AMUL.

$$\text{ULRI.K} = \text{MULIS.K} / \text{AMUL.K} \quad 13, A$$

ULRI - UTILITY OF LABOR RATIO IN INDUSTRY  
(DIMENSIONLESS)  
MULIS - MARGINAL UTILITY OF LABOR IN INDUSTRIAL  
SECTOR (UTILITY/PERSON)  
AMUL - AVERAGE MARGINAL UTILITY OF LABOR (UTILITY/  
LABOR)

Average marginal utility of labor AMUL, Equation 14, is the weighted average of marginal utility of labor in agricultural and industrial sectors, MULAS and MULIS, respectively. The weighting coefficients are the fraction of labor in two sectors.

$$AMUL.K = FLA.K * MULAS.K + (1 - FLA.K) * MULIS.K \quad 14, A$$

AMUL - AVERAGE MARGINAL UTILITY OF LABOR (UTILITY/  
LABOR)

FLA - FRACTION OF LABOR IN AGRICULTURE  
(DIMENSIONLESS)

MULAS - MARGINAL UTILITY OF LABOR IN AGRICULTURAL  
SECTOR (UTILITY/PERSON)

MULIS - MARGINAL UTILITY OF LABOR IN INDUSTRIAL  
SECTOR (UTILITY/PERSON)

Marginal utility of labor in agricultural sector MULAS, Equation 15, is the marginal utility from food availability MUFA times marginal productivity of labor in agricultural sector MPLAS.

$$MULAS.K = MUFA.K * MPLAS.K \quad 15, A$$

MULAS - MARGINAL UTILITY OF LABOR IN AGRICULTURAL  
SECTOR (UTILITY/PERSON)

MUFA - MARGINAL UTILITY FROM FOOD AVAILABILITY  
(UTILITY/1E6 RIALS OF FOOD/YEAR)

MPLAS - MARGINAL PRODUCTIVITY OF LABOR IN  
AGRICULTURAL SECTOR (1E6 RIALS/YEAR/  
PERSON)

In a similar way, marginal utility of labor in industrial sector MULIS, Equation 16, is equal to marginal utility from goods availability MUGA time marginal productivity of labor in industrial sector MPLIS.

$$MULIS.K = MUGA.K * MPLIS.K \quad 16, A$$

MULIS - MARGINAL UTILITY OF LABOR IN INDUSTRIAL  
SECTOR (UTILITY/PERSON)

MUGA - MARGINAL UTILITY FROM GOODS AVAILABILITY  
(UTILITY/1E6 RIALS OF GOODS/YEAR)

MPLIS - MARGINAL PRODUCTIVITY OF LABOR IN  
INDUSTRIAL SCETOR (1E6 RIALS /YEAR/  
PERSON)

Marginal utility from food availability MUFA is a function of food availability FA. Figure A.3 depicts the relationship between MUFA and FA. When food availability FA is one, marginal utility from food availability MUFA is assumed to be one. As food availability increases above one - i.e., as real supply of food becomes more than the amount of food that the nation with a certain production capability and economic

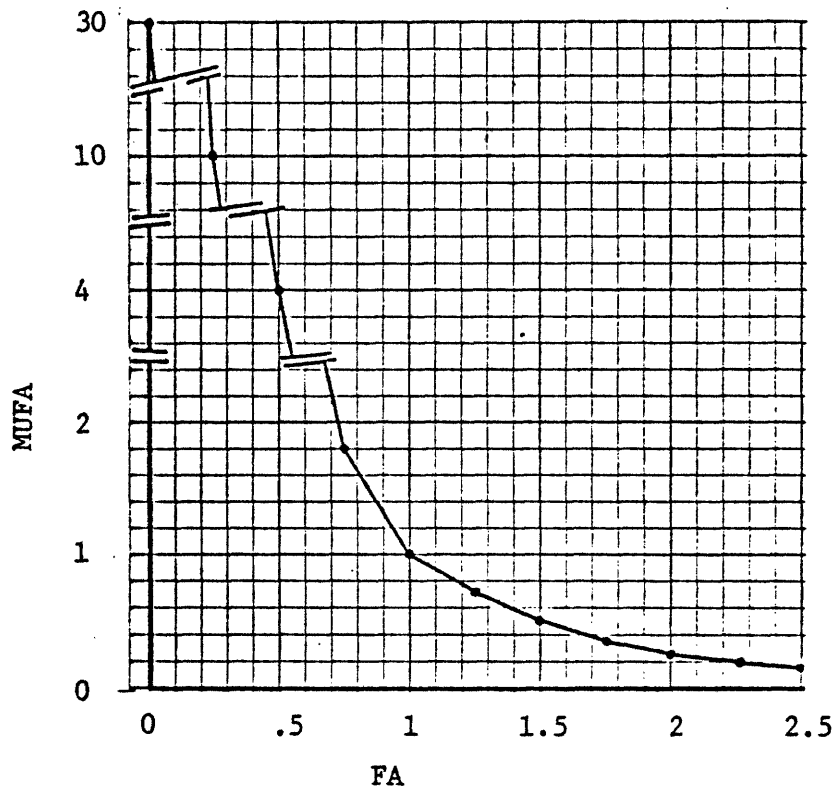

Figure A.3: Marginal Utility from Food Availability Versus Food Availability

```
MUFA.K=TABHL(TMUF A,FA.K,0,2.5,.25) 17; A
TMUF A=30/10/4/1.8/1/.7/.5/.35/.25/.2/.18 17.1, T
MUFA - MARGINAL UTILITY FROM FOOD AVAILABILITY
      (UTILITY/1E6 RIALS OF FOOD/YEAR)
TMUF A - TABLE FOR MARGINAL UTILITY FROM FOOD
        AVAILABILITY
FA - FOOD AVAILABILITY (DIMENSIONLESS)
```

output desires to consume - marginal utility from food availability MUFA drops. When FA is 2.5, MUFA become 0.2. In the other direction, as food availability drops, MUFA rises. In the extreme case where food availability is zero and people are starving, utility derived from one more unit of food should be extremely high. In Figure A.3, when FA is zero, MUFA is set equal to 30.

Marginal utility from goods availability MUGA, Equation 18, is a function of goods availability indicator GAI. The functional relationship is illustrated in Figure A.4. When goods availability indicator GAI is one, marginal utility from goods availability MUGA is set equal to 1. As GAI increases above one, MUGA drops with a decreasing slope. When GAI decreases, MUGA rises. For the zero value of GAI, MUGA becomes 2.5 much less than the value of MUFA, 30, at the extreme condition when FA is zero. The difference between extreme values of MUFA and MUGA indicates the greater importance of food as a basic need for survival at the very extreme conditions of zero availability of goods and food.

The (1,1) points in Figures A.3 and A.4 indicate that when FA and GAI are one, MUFA and MUGA are also one. Under such conditions, the reallocation of production factors is not necessary, based on the consideration of the marginal utility of the output of the two sectors. However, if, under such conditions, marginal productivity of factors in the two sectors differ, for a more efficient allocation, the reallocation of production factors becomes necessary and takes place in the system.

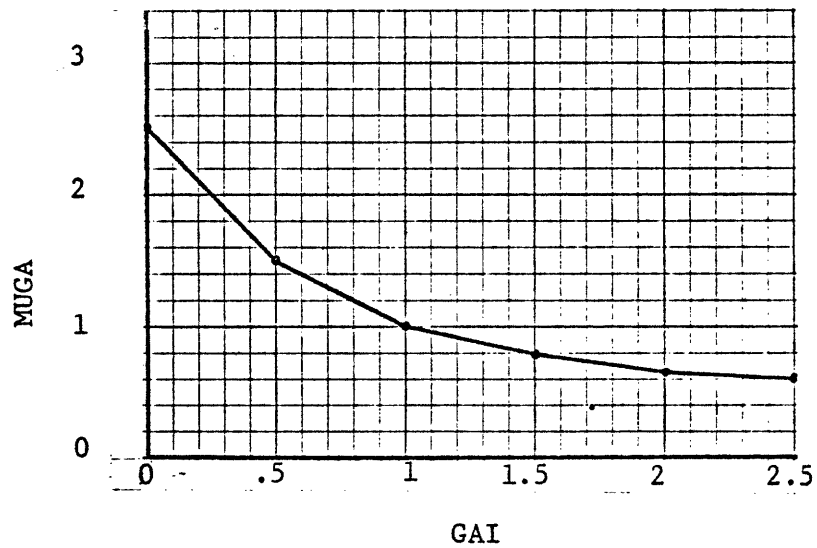

Figure A.4: Marginal Utility from Goods Availability Versus Goods Availability Indicator.

```
MUGA.K=TABHL(TMUGA,GAI.K,0,2.5,.5)           18, A
TMUGA=2.5/1.5/1/.8/.65/.6                    18.1, T
MUGA    - MARGINAL UTILITY FROM GOODS AVAILABILITY
          (UTILITY/1E6 RIALS OF GOODS/YEAR)
TMUGA   - TABLE FOR MARGINAL UTILITY FROM GOODS
          AVAILABILITY
GAI     - GOODS AVAILABILITY INDICATOR
          (DIMENSIONLESS)
```

The two marginal utility functions illustrated in Figures A.3 and A.4 imply that the aggregate utility function of the nation is assumed to be an additive function. In such a function, marginal utility from food is only a function of food availability and is independent of goods availability. Similarly, marginal utility from goods availability is independent of food availability and is only a function of goods availability. An alternative formulation is possible with a multiplicative utility function in which marginal utility of each output is a function of availability of both outputs. In addition, the current

formulation of marginal utility is in terms of availability of output rather than the absolute value of output per capita. A formulation in terms of the absolute value of output per capita probably functions more realistically under different sets of conditions.

Goods availability indicator GAI, Equation 19, is a weighted average of availability of the output of different non-agricultural sectors: availability of consumption goods AVCOG, availability of intermediate goods AVIG, availability of capital goods AVCAG, and availability of enrollment capacity (in the education sector) AVEC. The weighting coefficients are the fraction of production capacity in different sectors: the fraction of production capacity in consumption goods sector FPCON, the fraction of production capacity in intermediate goods sector FPI, the fraction of production capacity in capital goods sector FPCAP, and the fraction of production capacity in education sector FPE.

$$GAI.K = FPCAP.K * AVCAG.K + FPI.K * AVIG.K + FPCON.K * AVCOG.K + FPE.K * AVEC.K \quad 19, A$$

- GAI - GOODS AVAILABILITY INDICATOR (DIMENSIONLESS)
- FPCAP - FRACTION OF PRODUCTION CAPACITY IN CAPITAL GOODS SECTOR (DIMENSIONLESS)
- AVCAG - AVAILABILITY OF CAPITAL GOODS (DIMENSIONLESS)
- FPI - FRACTION OF PRODUCTION CAPACITY IN INTERMEDIATE GOODS SECTOR (DIMENSIONLESS)
- AVIG - AVAILABILITY OF INTERMEDIATE GOODS (DIMENSIONLESS)
- FPCON - FRACTION OF PRODUCTION CAPACITY IN CONSUMPTION GOODS SECTOR (DIMENSIONLESS)
- AVCOG - AVAILABILITY OF CONSUMPTION GOODS (DIMENSIONLESS)
- FPE - FRACTION OF PRODUCTION CAPACITY IN EDUCATION (DIMENSIONLESS)
- AVEC - AVAILABILITY OF ENROLLMENT CAPACITY (DIMENSIONLESS)

### A.1.2 Allocation of Capital

The equations that follow are for allocation of capital between agricultural and industrial sectors. These following equations and their descriptions are very similar to those for the allocation of labor. The descriptions of these equations which would be repetition of what was explained for the labor is omitted. Only the initial values of the average desired capital in each sector will be discussed.

The average desired capital in the two sectors at each point of time determine the fraction of capital in each sector. In order to start the simulation from 1959 with the right fraction of capital in each sector, average desired capital in each sector is initialized at the estimated actual capital in that sector in 1959. The average desired capital in agricultural sector initial ADCASN, Equation 23.2, is set equal to 70,500 million rials at 1972 constant prices. The average desired capital in industrial sector initial ADCISN, Equation 24.2, is set at 428,800 million rials at 1972 constant prices. The estimation of capital stock is based on time series data on investment from 1900 to 1959 and assumption about initial value of stock in 1900, gestation lag, and life time of capital.

Gross Domestic Fixed Capital Formation (GDFCF) and its composition in terms of structure and machinery from 1900 to 1965 at 1965 constant prices are given in Bharier (1969) pp. 128-129, and is copied in Columns 1, 2 and 3 of Table A.1 for the years 1900-1959. Bharier also gives the fraction of investment in agriculture (p.334) in 1900, 1930,

1932, 1946, 1956, and 1965. Fraction of investment in agriculture for other years during 1900-1959 is calculated through a linear extrapolation between given data points. Column 4 of Table A.1 shows the fraction for each year during the period. Based on GDFCF and fraction of investment in agriculture, total investment in agricultural and non-agricultural sectors are calculated and shown in Columns 1 and 4 of Table A.2, respectively. I assume the fraction of investment in machinery to total investment in each sector (agricultural and non-agricultural) to be the same as the fraction for the whole economy. Column 5 of Table A.1 shows fraction of investment in machinery for the whole economy which is calculated based on Columns 1 and 2 of that table. Based on the above assumption, Column 5 of Table A.1, and Columns 1 and 4 of Table A.2, investments in machinery and structure in the two sectors are calculated by the following formulas:

$$INSMA = (1 - FIMA) \times INNA$$

$$INMNA = FIMA \times INNA$$

$$INSA = (1 - FIMA) \times INAG$$

$$INMA = FIMA \times INAG$$

Where:

INSNA = Investment in structure in non-agricultural sector.

INMNA = Investment in machinery in non-agricultural sector.

INSA = Investment in structure in agricultural sector.

INMA = Investment in machinery in agricultural sector.

FIMA = Fraction of investment in machinery.

INNA = Total investment in non-agricultural sector.

INAG = Total investment in agricultural sector.



Table A-1  
 Gross Domestic Fixed Capital Formation by Its Components in Iran During 1900-1959  
 ( in billion Rials, at 1965 constant prices )

Year	( 1 ) Gross Domestic Fixed Capital Formation	( 2 ) Investment in Machinery	( 3 ) Investment in Buildings	( 4 ) Fraction of In- vestment in Agri- cultural Sector	( 5 ) Fraction of Investment in Machinery
1900.00	4.96000	1.91000	3.05000	.330000	.380000
1901.00	5.14000	2.04000	3.10000	.330000	.390000
1902.00	5.02000	2.03000	2.99000	.330000	.400000
1903.00	5.29000	2.18000	3.11000	.329000	.410000
1904.00	5.28000	2.18000	3.10000	.322000	.410000
1905.00	5.42000	2.31000	3.11000	.315000	.430000
1906.00	5.35000	2.26000	3.09000	.308000	.420000
1907.00	5.27000	2.17000	3.10000	.301000	.410000
1908.00	5.29000	2.19000	3.10000	.294000	.410000
1909.00	5.72000	2.62000	3.10000	.287000	.460000
1910.00	5.68000	2.50000	3.18000	.280000	.440000
1911.00	5.71000	2.65000	3.06000	.273000	.460000
1912.00	5.68000	2.51000	3.17000	.266000	.440000
1913.00	6.11000	2.89000	3.22000	.259000	.470000
1914.00	6.28000	3.07000	3.21000	.252000	.490000
1915.00	6.74000	3.54000	3.20000	.245000	.520000
1916.00	6.14000	2.97000	3.17000	.238000	.480000
1917.00	6.31000	3.13000	3.18000	.231000	.490000
1918.00	5.97000	2.85000	3.12000	.224000	.480000
1919.00	7.06000	3.85000	3.21000	.217000	.540000
1920.00	7.08000	3.47000	3.61000	.210000	.490000
1921.00	7.53000	3.88000	3.65000	.203000	.510000
1922.00	7.48000	4.22000	3.26000	.196000	.500000
1923.00	6.98000	3.50000	3.48000	.189000	.510000
1924.00	7.49000	4.05000	3.44000	.182000	.540000
1925.00	7.20000	3.77000	3.43000	.175000	.520000
1926.00	8.27000	5.08000	3.19000	.168000	.510000
1927.00	10.5200	6.72000	3.80000	.161000	.640000
1928.00	9.40000	5.95000	3.45000	.154000	.630000

Table A-1 (continued)

Year	( 1 )	( 2 )	( 3 )	( 4 )	( 5 )
1929.00	12.7400	8.77000	3.97000	.147000	.690000
1930.00	14.2300	9.22000	5.01000	.140000	.650000
1931.00	8.30000	4.72000	3.58000	.140000	.570000
1932.00	9.23000	5.68000	3.55000	.138000	.600000
1933.00	12.9200	7.72000	5.20000	.136000	.580000
1934.00	12.4100	7.16000	5.25000	.134000	.560000
1935.00	13.6100	7.74000	5.87000	.132000	.550000
1936.00	14.9800	8.26000	6.72000	.130000	.550000
1937.00	15.5800	8.71000	6.87000	.128000	.590000
1938.00	16.7700	9.88000	6.88999	.126000	.510000
1939.00	12.1400	6.14000	6.00000	.124000	.590000
1940.00	9.77000	4.86000	4.91000	.122000	.590000
1941.00	10.0400	4.97000	5.07000	.120000	.590000
1942.00	10.8600	5.45000	5.41000	.118000	.500000
1943.00	8.48000	3.18000	5.30000	.116000	.380000
1944.00	8.91000	3.59000	5.32000	.114000	.400000
1945.00	9.93000	4.49000	5.44000	.112000	.450000
1946.00	19.4800	5.85000	13.6300	.110000	.300000
1947.00	18.9900	5.60000	13.3900	.105000	.300000
1948.00	20.5500	5.41000	15.1400	.100000	.260000
1949.00	24.5300	7.74000	16.7900	.949999E-01	.300000
1950.00	23.9500	7.98000	15.9700	.899999E-01	.330000
1951.00	23.7100	7.37000	16.3400	.849999E-01	.310000
1952.00	23.1600	8.16000	15.0000	.799999E-01	.360000
1953.00	24.4500	9.01000	15.4400	.749999E-01	.400000
1954.00	29.2400	12.7900	16.4500	.699999E-01	.440000
1955.00	39.7500	16.9700	22.7800	.649999E-01	.430000
1956.00	43.8000	16.6800	27.1200	.599999E-01	.380000
1957.00	50.3200	19.2300	31.0900	.549999E-01	.370000
1958.00	65.4000	30.3100	35.0900	.599999E-01	.450000
1959.00	76.7900	37.6000	39.1900	.599999E-01	.470000

Table A-2  
 Investment in Agricultural and Non-agricultural Sectors in Iran During 1900-1959  
 ( in billion Rials, at 1965 constant prices )

Year	Investment in Agricultural Sector			Investment in Non-agricultural Sectors		
	Total ( 1 )	Buildings ( 2 )	Machinery ( 3 )	Total ( 4 )	Buildings ( 5 )	Machinery ( 6 )
1900.00	1.63000	1.01060	.619399	3.33000	2.06460	1.26540
1901.00	1.69000	1.03090	.659099	3.45000	2.10450	1.34550
1902.00	1.66000	.996000	.663999	3.36000	2.01600	1.34400
1903.00	1.74000	1.02660	.713399	3.55000	2.09450	1.45550
1904.00	1.70000	1.00300	.696999	2.18000	1.28620	.893799
1905.00	1.71000	.974699	.735299	3.71000	2.11470	1.59530
1906.00	1.65000	.956999	.692999	3.70000	2.14600	1.55400
1907.00	1.59000	.938099	.651899	3.68000	2.17120	1.50880
1908.00	1.55000	.914499	.635499	3.74000	2.20660	1.53340
1909.00	1.64000	.885600	.754399	4.08000	2.20320	1.87680
1910.00	1.59000	.890399	.699599	4.09000	2.29040	1.79960
1911.00	1.56000	.842399	.717599	4.15000	2.24100	1.90900
1912.00	1.51000	.845599	.664399	4.17000	2.33520	1.83480
1913.00	1.58000	.837400	.742599	4.53000	2.40090	2.12910
1914.00	1.58000	.805800	.774199	4.70000	2.39700	2.30300
1915.00	1.65000	.792000	.857999	5.09000	2.44320	2.64680
1916.00	1.46000	.759200	.700799	4.68000	2.43360	2.24640
1917.00	1.46000	.744600	.715399	4.85000	2.47350	2.37650
1918.00	1.34000	.696800	.643199	4.63000	2.40760	2.22240
1919.00	1.53000	.703800	.826199	5.53000	2.54380	2.98620
1920.00	1.49000	.759900	.730099	5.57000	2.84070	2.72930
1921.00	1.53000	.749700	.780299	6.00000	2.94000	3.06000
1922.00	1.47000	.735000	.734999	6.01000	3.00500	3.00500
1923.00	1.32000	.646800	.673199	5.66000	2.77340	2.88660
1924.00	1.36000	.625600	.734399	6.13000	2.81980	3.31020
1925.00	1.26000	.604800	.655199	5.94000	2.85120	3.08880
1926.00	1.39000	.681099	.708899	6.88000	3.37120	3.50880
1927.00	1.69000	.608400	1.08160	8.83000	3.17880	5.65120

Table A-2 ( continued )

Year	( 1 )	( 2 )	( 3 )	( 4 )	( 5 )	( 6 )
1928.00	1.44000	.532800	.907199	7.96000	2.94520	5.01480
1929.00	1.87000	.579700	1.29030	10.8700	3.36970	7.50030
1930.00	1.99000	.696500	1.29350	12.2400	4.28400	7.95600
1931.00	1.16000	.498800	.661199	7.14000	3.07020	4.06980
1932.00	1.27000	.508000	.761999	7.96000	3.18400	4.77600
1933.00	1.76000	.739200	1.02080	11.1600	4.68720	6.47280
1934.00	1.66000	.730400	.929599	10.7500	4.73000	6.02000
1935.00	1.80000	.810000	.989999	11.8100	5.31450	6.49550
1936.00	1.95000	.877500	1.07250	13.0300	5.86350	7.16650
1937.00	1.99000	.815900	1.17410	13.5900	5.57190	8.01810
1938.00	2.11000	1.03390	1.07610	14.6600	7.18340	7.47660
1939.00	1.51000	.619100	.890899	10.6300	4.35830	6.27170
1940.00	1.19000	.487900	.702099	8.58000	3.51780	5.06220
1941.00	1.20000	.492000	.708000	8.84000	3.62440	5.21500
1942.00	1.28000	.640000	.640000	9.58000	4.79000	4.79000
1943.00	.980000	.607600	.372400	7.50000	4.65000	2.85000
1944.00	1.02000	.612000	.408000	7.89000	4.73400	3.15600
1945.00	1.11000	.610499	.499499	8.82000	4.85100	3.96900
1946.00	2.14000	1.49800	.642000	17.3400	12.1380	5.20199
1947.00	1.99000	1.39300	.596999	17.0000	11.9000	5.10000
1948.00	2.05000	1.51700	.533000	18.5000	13.6900	4.80999
1949.00	2.33000	1.63100	.698999	22.2000	15.5400	6.66000
1950.00	2.15000	1.44050	.709499	21.8000	14.6060	7.19399
1951.00	2.01000	1.38690	.623100	21.7000	14.9730	6.72700
1952.00	1.85000	1.18400	.665999	21.3100	13.6384	7.67159
1953.00	1.84000	1.10400	.735999	22.6100	13.5660	9.04399
1954.00	2.05000	1.14800	.901999	27.1900	15.2264	11.9636
1955.00	2.58000	1.47060	1.10940	37.1700	21.1869	15.9831
1956.00	2.63000	1.63060	.999399	41.1700	25.5254	15.6446
1957.00	3.02000	1.90260	1.11740	47.3000	29.7990	17.5010
1958.00	3.92000	2.15600	1.76400	61.4800	33.8140	27.6660
1959.00	4.61000	2.44330	2.16670	72.1800	38.2554	33.9246
1960.00	4.53000	2.26500	2.26500	71.0400	35.5200	35.5200
1961.00	4.28000	2.26840	2.01160	67.0400	35.5312	31.508d
1962.00	3.99000	2.23440	1.75560	62.5800	35.0448	27.5352
1963.00	3.60000	2.01600	1.58400	56.4700	31.6232	24.8468
1964.00	4.74000	2.65440	2.08560	74.3100	41.6136	32.6964
1965.00	6.05000	3.26700	2.78300	94.8500	51.2190	43.6310

To determine capital stock in each sector, assumptions about life of capital stock, and gestation lag should be made. There are different assumptions about life time of capital in the literature. For example, George Jasz, et. al. (1962) use life time between 29 and 80 years for different buildings and life time between 10 and 13 years for equipments in different sectors. Kuznets (1966) p. 258, assumes life times of 50 years for buildings and 10 years for producer's equipment. In this study, life times of 50 years for buildings and 12 years for equipment are assumed, both in agricultural and non-agricultural sectors. These life times are used to calculate "declining balance depreciation" in a "net capital stock" time series.

Gestation lag is assumed to be two years. This assumption means that it takes two years before investment can be added to the productive capital stock.

To set initial value of capital stock, I assume that stock of each item was at stagnation in 1902. So initial value of each item in 1902 equals investment in 1900 times life time of that item. Based on these assumptions, time series on stock of machinery and buildings at 1965 constant prices in both agricultural and non-agricultural sectors for 1902 through 1959 are calculated and shown in Table A.3

In order to determine the values of capital stock in 1959 in terms of 1972 prices, the values given in Table A.3 for 1959 should be divided by 0.794, which is the correspondent deflator given in SRU March 1976. In SRU March 1976, Table 105, 1965 deflator for investment in machinery and equipment based on 1972 prices is 79.4, and in Table 107, 1965 deflator for construction

Table A-3

Capital Stocks in Agricultural and Non-agricultural Sectors in Iran During 1903-1959  
( in billion Rials, at 1965 constant prices )

Year	Agricultural Sector			Non-agricultural Sectors		
	Total ( 1 )	Buildings ( 2 )	Machinery ( 3 )	Total ( 4 )	Buildings ( 5 )	Machinery ( 6 )
1902.00	47.8567	40.4240	7.43279	97.7687	82.5839	15.1848
1903.00	47.8568	40.4240	7.43279	97.7687	82.5840	15.1848
1904.00	47.9167	40.4443	7.47249	97.8887	82.6238	15.2649
1905.00	47.9429	40.4291	7.51378	97.9110	82.5742	15.3368
1906.00	48.0460	40.4450	7.60103	98.1186	82.6044	15.5142
1907.00	48.1014	40.4368	7.66461	96.9406	81.8255	15.1152
1908.00	48.1618	40.4006	7.76119	97.3454	81.8945	15.4509
1909.00	48.1550	40.3476	7.80742	97.7104	81.9931	15.7173
1910.00	48.0857	40.2770	7.80870	98.0308	82.1145	15.9163
1911.00	47.9780	40.1845	7.79348	98.3916	82.2682	16.1234
1912.00	47.9639	40.0655	7.89842	99.0712	82.4147	16.6565
1913.00	47.8940	39.9542	7.93981	99.7128	82.6447	17.0681
1914.00	47.7935	39.7978	7.99576	100.374	82.8196	17.5547
1915.00	47.6423	39.6484	7.99385	101.011	83.0843	17.9266
1916.00	47.5649	39.4946	8.07029	101.970	83.4080	18.5618
1917.00	47.4850	39.3130	8.17196	103.038	83.7198	19.3180
1918.00	47.4711	39.1222	8.34897	104.425	84.0700	20.3549
1919.00	47.2573	38.9033	8.35402	105.307	84.4018	20.9051
1920.00	47.0486	38.6753	8.37325	106.305	84.7653	21.5395
1921.00	46.7239	38.4052	8.31868	107.021	85.0537	21.9669
1922.00	46.6005	38.1489	8.45165	108.594	85.4712	23.1225
1923.00	46.4324	37.9550	8.47745	110.100	86.1751	23.9249
1924.00	46.3071	37.7558	8.55129	111.952	86.9607	24.9912
1925.00	46.1206	37.5469	8.57368	113.705	87.7917	25.9135
1926.00	45.7874	37.2550	8.53241	115.011	88.3703	26.6407

Table A-3 ( continued )

Year	( 1 )	( 2 )	( 3 )	( 4 )	( 5 )	( 6 )
1927.00	45.5050	36.9492	8.55577	116.712	88.9808	27.7308
1928.00	45.1283	36.6303	8.49799	118.116	89.6075	28.5087
1929.00	44.8943	36.3956	8.49872	120.380	90.7385	29.6417
1930.00	44.9662	36.0941	8.87209	124.472	91.6488	32.8228
1931.00	44.7645	35.7245	9.03995	127.405	92.3028	35.1023
1932.00	44.9880	35.4111	9.57692	133.042	93.3649	39.6774
1933.00	45.2946	35.2223	10.0723	139.642	95.3148	44.3269
1934.00	44.7347	34.8405	9.89418	140.705	96.0021	44.7028
1935.00	44.3092	34.4775	9.83166	142.540	96.7860	45.7536
1936.00	44.3879	34.3548	10.0332	147.467	99.0535	48.4135
1937.00	44.3530	34.2263	10.1267	151.706	101.307	50.3991
1938.00	44.4534	34.1806	10.2728	156.784	104.089	52.6946
1939.00	44.6928	34.2036	10.4892	162.820	107.350	55.4699
1940.00	44.9536	34.1644	10.7892	169.104	110.238	58.8655
1941.00	45.3103	34.3442	10.9662	176.102	114.666	61.4366
1941.00	45.3103	34.3442	10.9662	176.102	114.666	62.5886
1942.00	45.0479	34.1046	10.9432	178.746	116.157	62.4350
1943.00	44.4733	33.7399	10.7334	179.206	116.771	62.4477
1944.00	43.9353	33.3884	10.5470	179.924	117.476	62.0337
1945.00	43.5017	33.1937	10.3080	181.363	119.329	59.7142
1946.00	42.7928	32.9714	9.82143	180.710	120.996	57.8940
1947.00	42.1701	32.7591	9.41098	180.599	122.705	57.0385
1948.00	41.6768	32.5506	9.12623	181.527	124.489	57.7966
1949.00	42.2426	33.2348	9.00771	191.002	133.514	57.7902
1950.00	42.6510	33.7970	8.85407	199.873	142.077	59.6344
1951.00	43.1183	34.4690	8.64923	210.005	152.215	61.8588
1952.00	43.8658	35.2383	8.62746	223.584	163.949	63.4309
1953.00	44.4158	35.7978	8.61800	236.315	174.456	
1954.00	44.8127	36.2897	8.52293	248.499	185.068	65.8166
1955.00	45.0452	36.5665	8.47869	259.896	194.080	69.3758
1956.00	45.2644	36.7563	8.50813	272.169	202.794	75.5581
1957.00	45.6865	36.9854	8.70112	288.508	212.950	85.2446
1958.00	46.6168	37.5313	9.08542	314.058	228.813	93.7855
1959.00	47.5513	38.2236	9.32770	342.404	248.618	103.471

based on 1972 prices is 79.38. As a result, in 1959, total capital stock in agricultural and non-agricultural sectors are 428.8 and 70.5 billion rials at 1972 constant prices, respectively.

$CAPAS.K = FCA.K * CAP.K$  20, A  
CAPAS - CAPITAL IN AGRICULTURAL SECTOR (1E6 RIALS)  
FCA - FRACTION OF CAPITAL IN AGRICULTURE  
(DIMENSIONLESS)  
CAP - CAPITAL STOCK (1E6 RIALS)

$CAPIS.K = (1 - FCA.K) * CAP.K$  21, A  
CAPIS - CAPITAL IN INDUSTRIAL SECTOR (1E6 RIALS)  
FCA - FRACTION OF CAPITAL IN AGRICULTURE  
(DIMENSIONLESS)  
CAP - CAPITAL STOCK (1E6 RIALS)

$FCA.K = ADCAS.K / (ADCAS.K + ADCIS.K)$  22, A  
FCA - FRACTION OF CAPITAL IN AGRICULTURE  
(DIMENSIONLESS)  
ADCAS - AVERAGE DESIRED CAPITAL IN AGRICULTURAL  
SECTOR (1E6 RIALS)  
ADCIS - AVERAGE DESIRED CAPITAL IN INDUSTRIAL  
SECTOR (1E6 RIALS)

$ADCAS.K = ADCAS.J + DT * ((DCAS.J - ADCAS.J) / TAC)$  23, L  
ADCAS=ADCASN 23.1, N  
ADCASN=70500 23.2, C  
TAC=20 23.3, C  
ADCAS - AVERAGE DESIRED CAPITAL IN AGRICULTURAL  
SECTOR (1E6 RIALS)  
DCAS - DESIRED CAPITAL IN AGRICULTURAL SECTOR (1E6  
RIALS)  
TAC - TIME TO ADJUST CAPITAL (YEARS)  
ADCASN - AVERAGE DESIRED CAPITAL IN AGRICULTURAL  
SECTOR INITIAL (1E6 RIALS)

$ADCIS.K = ADCIS.J + DT * ((DCIS.J - ADCIS.J) / TAC)$  24, L  
ADCIS=ADCISN 24.1, N  
ADCISN=428800 24.2, C  
ADCIS - AVERAGE DESIRED CAPITAL IN INDUSTRIAL  
SECTOR (1E6 RIALS)  
DCIS - DESIRED CAPITAL IN INDUSTRIAL SECTOR (1E6  
RIALS)  
TAC - TIME TO ADJUST CAPITAL (YEARS)  
ADCISN - AVERAGE DESIRED CAPITAL IN INDUSTRIAL  
SECTOR INITIAL (1E6 RIALS)



DCAS.K=CAPAS.K\*MCAS.K 25, A  
DCAS - DESIRED CAPITAL IN AGRICULTURAL SECTOR (1E6  
RIALS)  
CAPAS - CAPITAL IN AGRICULTURAL SECTOR (1E6 RIALS)  
MCAS - MULTIPLIER FOR CAPITAL IN AGRICULTURAL  
SECTOR (DIMENSIONLESS)

DCIS.K=CAPIS.K\*MCIS.K 26, A  
DCIS - DESIRED CAPITAL IN INDUSTRIAL SECTOR (1E6  
RIALS)  
CAPIS - CAPITAL IN INDUSTRIAL SECTOR (1E6 RIALS)  
MCIS - MULTIPLIER FOR CAPITAL IN INDUSTRIAL SECTOR  
(DIMENSIONLESS)

MCAS.K=TABHL(TMCAS,UCRA.K,0,5,1) 27, A  
TMCAS=0/1/1.8/2.4/2.8/3 27.1, T  
MCAS - MULTIPLIER FOR CAPITAL IN AGRICULTURAL  
SECTOR (DIMENSIONLESS)  
TMCAS - TABLE FOR MULTIPLIER FOR CAPITAL IN  
AGRICULTURAL SECTOR  
UCRA - UTILITY OF CAPITAL RATIO IN AGRICULTURE  
(DIMENSIONLESS)

MCIS.K=TABHL(TMCIS,UCRI.K,0,5,1) 28, A  
TMCIS=0/1/1.8/2.4/2.8/3 28.1, T  
MCIS - MULTIPLIER FOR CAPITAL IN INDUSTRIAL SECTOR  
(DIMENSIONLESS)  
TMCIS - TABLE FOR MULTIPLIER FOR CAPITAL IN  
INDUSTRIAL SECTOR  
UCRI - UTILITY OF CAPITAL RATIO IN INDUSTRY  
(DIMENSIONLESS)

UCRA.K=MUCAS.K/AMUC.K 29, A  
UCRA - UTILITY OF CAPITAL RATIO IN AGRICULTURE  
(DIMENSIONLESS)  
MUCAS - MARGINAL UTILITY OF CAPITAL IN AGRICULTURAL  
SECTOR (UTILITY/1E6 RIALS)  
AMUC - AVERAGE MARGINAL UTILITY OF CAPITAL  
(UTILITY/1E6 RIALS)

UCRI.K=MUCIS.K/AMUC.K 30, A  
UCRI - UTILITY OF CAPITAL RATIO IN INDUSTRY  
(DIMENSIONLESS)  
MUCIS - MARGINAL UTILITY OF CAPITAL IN INDUSTRIAL  
SECTOR (UTILITY/1E6 RIALS)  
AMUC - AVERAGE MARGINAL UTILITY OF CAPITAL  
(UTILITY/1E6 RIALS)

AMUC.K=FCA.K\*MUCAS.K+(1-FCA.K)\*MUCIS.K 31, A  
AMUC - AVERAGE MARGINAL UTILITY OF CAPITAL  
(UTILITY/1E6 RIALS)  
FCA - FRACTION OF CAPITAL IN AGRICULTURE  
(DIMENSIONLESS)  
MUCAS - MARGINAL UTILITY OF CAPITAL IN AGRICULTURAL  
SECTOR (UTILITY/1E6 RIALS)  
MUCIS - MARGINAL UTILITY OF CAPITAL IN INDUSTRIAL  
SECTOR (UTILITY/1E6 RIALS)

MUCAS.K=MUFA.K\*MPCAS.K 32, A  
MUCAS - MARGINAL UTILITY OF CAPITAL IN AGRICULTURAL  
SECTOR (UTILITY/1E6 RIALS)  
MUFA - MARGINAL UTILITY FROM FOOD AVAILABILITY  
(UTILITY/1E6 RIALS OF FOOD/YEAR)  
MPCAS - MARGINAL PRODUCTIVITY OF CAPITAL IN  
AGRICULTURAL SECTOR (1E6 RIALS/YEAR/1E6  
RIALS)

MUCIS.K=MUGA.K\*MPCIS.K 33, A  
MUCIS - MARGINAL UTILITY OF CAPITAL IN INDUSTRIAL  
SECTOR (UTILITY/1E6 RIALS)  
MUGA - MARGINAL UTILITY FROM GOODS AVAILABILITY  
(UTILITY/1E6 RIALS OF GOODS/YEAR)  
MPCIS - MARGINAL PRODUCTIVITY OF CAPITAL IN  
INDUSTRIAL SECTOR (1E6 RIALS/YEAR/1E6  
RIALS)

### A.1.3 Allocation of Education

The education level of the labor force, measured in man-years-of-schooling, is considered as a production factor in the model. Education, like labor and capital, is allocated between the agricultural and industrial sectors. The equations which simulate the allocation of education are similar to the equations for the allocation of labor and capital. A documenter list of the equations for the allocation of education follows. A full description of the equations, which would be similar to what was explained for the allocation of labor, is omitted. Only the initial values of education and multiplier for education in the two sectors will be explained.

The average desired education in the two sectors at each point of time determine the fraction of education in each sector. In order to start the simulation from 1959 with the right fraction of education in each sector, average desired education in each sector is initialized at the estimated actual educational level in that sector in 1959. The average desired education in agricultural sector initial ADEASN, Equation 27.2, is set at 1780 thousand man-years of schooling. The average desired education in industrial sector initial ADEISN, Equation 38.2, is set at 8220 thousand man-years of schooling. These initial values, as given in Table A.4, are derived based on the available data. Table A.4 shows the educational attainment of total labor force in 1956, 1966 and 1972. Based on data given in Table A.4, total educational level in the country in 1956, 1966 and 1972, and the education level in the agricultural sector in 1966 and 1972 are determined using the following formula:

Table A.4  
 Labor Force by Education Level in Iran  
 (in persons)

	Total			Agricultural Sector		
	1956	1966	1972	1956	1966	1972
Illiterates	9,938,362	5,538,530	5,093,814	--	3,123,107	2,779,237
Literates Without Degree	190,987	473,795	1,900,953	--	191,319	554,119
Primary School Graduates	454,713	1,028,899		--	226,509	
High School Graduates	324,464	387,520	523,888	--	12,179	14,437
Higher Education Graduates	37,170	78,962	116,978	--	477	--

Sources: (1) Statistical Yearbook; 1974, Unesco, U.N.  
 (2) Iran Statistical Yearbook; 1971, p. 58.  
 (3) Plan and Budget Organization: Natajege Amargirle Niroie Ensani 1351, ( in Farsi), p. 86.

$$\text{Education Level} = (\text{Literates} + \text{Primary School Graduates}) \times 6 \\ + (\text{High School Graduates}) \times 12 + \text{Higher} \\ \text{Education Graduates}) \times 16$$

The results are shown in Table A.5. Table A.5 also shows the ratio of education in agricultural to non-agricultural sectors in 1966 and 1972. The average growth rate of total education level during 1956-1966 and 1966-1972 are 5.72 and 4.53, respectively. Based on these average growth rate, a time series on total education level is constructed and shown in Table A.6. The values of education level in 1973 and 1974 are based on the assumption that the growth rate from 1972 to 1974 remains the same as the growth rate from 1966 to 1972. In addition, through a linear extrapolation of the ratio of education in agricultural to non-agricultural sectors in 1966 and 1972, a value for the ratio is calculated for each year during 1959-1974. Using this ratio and total education level, education in agricultural and non-agricultural sectors are determined from 1959 through 1974 and shown in Table A.6. The value of education in the agricultural and non-agricultural sectors in 1959 are used to initialize average desired education in two sectors in 1959.

The other point to be discussed in relation to the equations for the allocation of education is about multiplier for education in the two sectors. Figures A.5 and A.6 show the functional relationship between multiplier for education in each sector and the utility ratio of education in that sector for both sectors. The general shape of these relationships is similar to those for allocation of labor, shown in Figures A.1 and A.2. However, in Figures

Table A.5

Education Level in Iran  
(in 1000 man-years of schooling)

<u>Year</u>	<u>Total</u>	<u>Agricultural Sector</u>	<u>Non-Agricultural Sector</u>	<u>Ratio of Agricultural to Non-Agricultural Sector</u>
1956	8,422	--	--	--
1966	14,930	2,661	12,269	0.1782
1972	19,594	3,498	16,096	0.1785

Source: Based on Table A.4.

Table A.6

Education Level in Agricultural and Non-Agricultural Sectors in Iran  
(in 1000 man-years of schooling)

<u>Year</u>	<u>Total</u>	<u>Agricultural Sector</u>	<u>Non-Agricultural Sector</u>
1959	10,000	1,780	8,220
1960	10,589	1,885	8,704
1961	11,213	1,996	9,217
1962	11,874	2,114	9,760
1963	12,574	2,238	10,336
1964	13,315	2,370	10,945
1965	14,099	2,510	11,589
1966	14,930	2,661	12,269
1967	15,622	2,781	12,841
1968	16,346	2,910	13,346
1969	17,104	3,045	14,059
1970	17,846	3,185	14,711
1971	18,726	3,333	15,393
1972	19,594	3,498	16,096
1973	20,502	3,649	16,853
1974	21,452	3,818	17,634

Source: Derived by the author based on Tables A.4 and A.5.

A.5 and A.6, for the same non-zero values of utility of education ratio in agriculture UERA and utility of education ratio in industry UERI, multiplier for education in industrial sector MEIS is greater than multiplier for education in agricultural sector MEAS. For example, when utility of education ratio in both sectors are one, indicating that marginal utility of education in both sectors are the same, MEIS is 1.25 and MEAS is 0.8. This difference between MEAS and MEIS is based on the assumption that educated people prefer urban to rural areas. Educational, cultural, social, and other facilities available in the urban areas are attractive to educated people. With the same job opportunities and income, represented by marginal utility of education, in urban and rural areas, educated people would prefer to live in the cities. Figures A.5 and A.6 are drawn to reflect the above assumption about the preference of educated people in the difference between the values of MEAS and MEIS for the same values of UERA and UERI.

$EAS.K = FEA.K * E.K$  34, A  
EAS - EDUCATION IN AGRICULTURAL SECTOR (1000 MAN-YEARS-OF-SCHOOLING)  
FEA - FRACTION OF EDUCATION IN AGRICULTURAL SECTOR (DIMENSIONLESS)  
E - EDUCATION (1000 MAN-YEARS OF SCHOOLING)

$EIS.K = (1 - FEA.K) * E.K$  35, A  
EIS - EDUCATION IN INDUSTRIAL SECTOR (1000 MAN-YEARS-OF-SCHOOLING)  
FEA - FRACTION OF EDUCATION IN AGRICULTURAL SECTOR (DIMENSIONLESS)  
E - EDUCATION (1000 MAN-YEARS OF SCHOOLING)

FEA.K=ADEAS.K/(ADEAS.K+ADEIS.K) 36, A  
FEA - FRACTION OF EDUCATION IN AGRICULTURAL  
SECTOR (DIMENSIONLESS)  
ADEAS - AVERAGE DESIRED EDUCATION IN AGRICULTURAL  
SECTOR (1000 MAN-YEARS-OF-SCHOOLING)  
ADEIS - AVERAGE DESIRED EDUCATION IN INDUSTRIAL  
DECTOR (1000 MAN-YEARS-OF-SCHOOLING)

ADEAS.K=ADEAS.J+DT\*((DEAS.J-ADEAS.J)/TAE) 37, L  
ADEAS=ADEASN 37.1, N  
ADEASN=1780 37.2, C  
TAE=15 37.3, C  
ADEAS - AVERAGE DESIRED EDUCATION IN AGRICULTURAL  
SECTOR (1000 MAN-YEARS-OF-SCHOOLING)  
DEAS - DESIRED EDUCATION IN AGRICULTURAL SECTOR  
(1000 MAN-YEARS-OF-SCHOOLING)  
TAE - TIME TO ADJUST EDUCATION (YEARS)  
ADEASN - AVERAGE DESIRED EDUCATION IN AGRICULTURAL  
SECTOR INITIAL (1000 MAN-YEARS-OF-  
SCHOOLING)

ADEIS.K=ADEIS.J+DT\*((DEIS.J-ADEIS.J)/TAE) 38, L  
ADEIS=ADEISN 38.1, N  
ADEISN=8220 38.2, C  
ADEIS - AVERAGE DESIRED EDUCATION IN INDUSTRIAL  
DECTOR (1000 MAN-YEARS-OF-SCHOOLING)  
DEIS - DESIRED EDUCATION IN INDUSTRIAL SECTOR  
(1000 MAN-YEARS-OF-SCHOOLING)  
TAE - TIME TO ADJUST EDUCATION (YEARS)  
ADEISN - AVERAGE DESIRED EDUCATION IN INDUSTRIAL  
SECTOR INITIAL (1000 MAN-YEARS-OF-  
SCHOOLING)

DEAS.K=MEAS.K\*EAS.K 39, A  
DEAS - DESIRED EDUCATION IN AGRICULTURAL SECTOR  
(1000 MAN-YEARS-OF-SCHOOLING)  
MEAS - MULTIPLIER FOR EDUCATION IN AGRICULTURAL  
SECTOR (DIMENSIONLESS)  
EAS - EDUCATION IN AGRICULTURAL SECTOR (1000 MAN-  
YEARS-OF-SCHOOLING)

DEIS.K=MEIS.K\*EIS.K 40, A  
DEIS - DESIRED EDUCATION IN INDUSTRIAL SECTOR  
(1000 MAN-YEARS-OF-SCHOOLING)  
MEIS - MULTIPLIER FOR EDUCATION IN INDUSTRIAL  
SECTOR (DIMENSIONLESS)  
EIS - EDUCATION IN INDUSTRIAL SECTOR (1000 MAN-  
YEARS-OF-SCHOOLING)



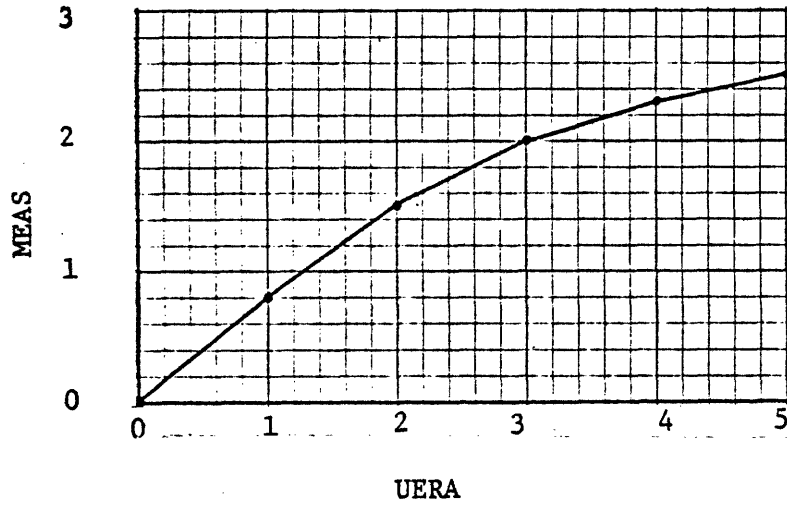

Figure A.5: Multiplier for Education in Agricultural Sector Versus Utility of Education in Agriculture

```
MEAS.K=TABHL(TMEAS, UERA.K, 0, 5, 1)                                41, A
TMEAS=0/.8/1.5/2/2.3/2.5                                           41.1, .T
  MEAS  - MULTIPLIER FOR EDUCATION IN AGRICULTURAL
          SECTOR (DIMENSIONLESS)
  TMEAS - TABLE FOR MULTIPLIER FOR EDUCATION IN
          AGRICULTURAL SECTOR
  UERA  - UTILITY OF EDUCATION RATIO IN AGRICULTURE
          (DIMENSIONLESS)
```

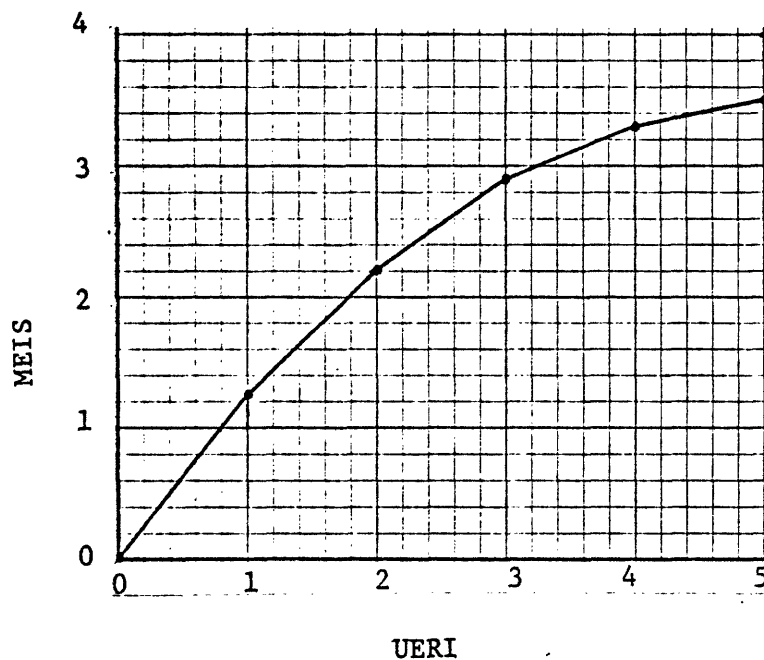

Figure A.6: Multiplier for Education in Industrial Sector Versus Utility of Education Ratio in Industry

```
MEIS.K=TABHL(TMEIS,UERI.K,0,5,1)                                42, A
TMEIS=0/1.25/2.2/2.9/3.3/3.5                                    42.1, T
  MEIS    - MULTIPLIER FOR EDUCATION IN INDUSTRIAL
             SECTOR (DIMENSIONLESS)
  TMEIS   - TABLE FOR MULTIPLIER FOR EDUCATION IN
             INDUSTRIAL SECTOR
  UERI    - UTILITY OF EDUCATION RATIO IN INDUSTRY
             (DIMENSIONLESS)
```

$UERA.K = MUEAS.K / AMUE.K$  43, A  
UERA - UTILITY OF EDUCATION RATIO IN AGRICULTURE  
(DIMENSIONLESS)  
MUEAS - MARGINAL UTILITY OF EDUCATION IN  
AGRICULTURAL SECTOR (UTILITY/1000 MAN-  
YEARS-OF-SCHOOLING)  
AMUE - AVERAGE MARGINAL UTILITY OF EDUCATION  
(UTILITY/1000 MAN-YEARS-OF-SCHOOLING)

$UERI.K = MUEIS.K / AMUE.K$  44, A  
UERI - UTILITY OF EDUCATION RATIO IN INDUSTRY  
(DIMENSIONLESS)  
MUEIS - MARGINAL UTILITY OF EDUCATION IN INDUSTRIAL  
SECTOR (UTILITY/1E6 RIALS)  
AMUE - AVERAGE MARGINAL UTILITY OF EDUCATION  
(UTILITY/1000 MAN-YEARS-OF-SCHOOLING)

$AMUE.K = FEA.K * MUEAS.K + (1 - FEA.K) * MUEIS.K$  45, A  
AMUE - AVERAGE MARGINAL UTILITY OF EDUCATION  
(UTILITY/1000 MAN-YEARS-OF-SCHOOLING)  
FEA - FRACTION OF EDUCATION IN AGRICULTURAL  
SECTOR (DIMENSIONLESS)  
MUEAS - MARGINAL UTILITY OF EDUCATION IN  
AGRICULTURAL SECTOR (UTILITY/1000 MAN-  
YEARS-OF-SCHOOLING)  
MUEIS - MARGINAL UTILITY OF EDUCATION IN INDUSTRIAL  
SECTOR (UTILITY/1E6 RIALS)

$MUEAS.K = MUFA.K * MPEAS.K$  46, A  
MUEAS - MARGINAL UTILITY OF EDUCATION IN  
AGRICULTURAL SECTOR (UTILITY/1000 MAN-  
YEARS-OF-SCHOOLING)  
MUFA - MARGINAL UTILITY FROM FOOD AVAILABILITY  
(UTILITY/1E6 RIALS OF FOOD/YEAR)  
MPEAS - MARGINAL PRODUCTIVITY OF EDUCATION IN  
AGRICULTURAL SECTOR (1E6 RIALS/YEAR/1000  
MAN-YEARS-OF-SCHOOLING)

$MUEIS.K = MUGA.K * MPEIS.K$  47, A  
MUEIS - MARGINAL UTILITY OF EDUCATION IN INDUSTRIAL  
SECTOR (UTILITY/1E6 RIALS)  
MUGA - MARGINAL UTILITY FROM GOODS AVAILABILITY  
(UTILITY/1E6 RIALS OF GOODS/YEAR)  
MPEIS - MARGINAL PRODUCTIVITY OF EDUCATION IN  
INDUSTRIAL SECTOR (1E6 RIALS/YEAR/1000  
MAN-YEARS-OF-SCHOOLING)

## A.2 AGRICULTURAL SECTOR

Food availability, Equation 49, is equal to total food TF divided by domestic demand for food DDF.

$$\text{FA.K} = \text{TF.K} / \text{DDF.K} \quad 49, \text{ A}$$

FA - FOOD AVAILABILITY (DIMENSIONLESS)  
TF - TOTAL FOOD (1E6 RIALS/YEAR)  
DDF - DOMESTIC DEMAND FOR FOOD (1E6 RIALS/YEAR)

Total food TF, Equation 50, is food output FOUT plus imported food IF minus exported food EF.

$$\text{TF.K} = \text{FOUT.K} + \text{IF.K} - \text{EF.K} \quad 50, \text{ A}$$

TF - TOTAL FOOD (1E6 RIALS/YEAR)  
FOUT - FOOD OUTPUT (1E6 RIALS/YEAR)  
IF - IMPORTED FOOD (1E6 RIALS/YEAR)  
EF - EXPORTED FOOD (1E6 RIALS/YEAR)

Food output FOUT, Equation 51, is food output per labor FOL times labor in agricultural sector LAS.

$$\text{FOUT.K} = \text{FOL.K} * (\text{LAS.K} / 1000000) \quad 51, \text{ A}$$

FOUT - FOOD OUTPUT (1E6 RIALS/YEAR)  
FOL - FOOD OUTPUT PER LABORER (RIALS/YEAR/PERSON)  
LAS - LABOR IN AGRICULTURAL SECTOR (PERSONS)

Food output per labor FOL, Equation 52, is based on potential food output per laborer PFOL, primitive food output per laborer PRFOL, and multiplier for food output per laborer from oil availability MFOLO. As equation 52 shows, when MFOLO is one, indicating that all the desired oil is available and there is no oil shortage, food output per laborer FOL is equal

to the potential food output per laborer PFOL. As MFOLO becomes less than one, indicating an effect of the existence of an oil shortage, FOL drops below PFOL and towards the primitive food output per laborer PRFOL. The intensity of the effect of an oil shortage on food output per laborer depends upon the difference between the potential food output per laborer PFOL and primitive food output per laborer. If potential food output per laborer PFOL is the same as primitive food output per laborer PRFOL - i.e., the agricultural sector is at a primitive level - an oil shortage does not affect the agricultural output at all. The higher the difference between PFOL and PRFOL, the higher will be the effect of an oil shortage on food output per laborer and therefore the higher the effect on agricultural output.

$$FOL.K = MFOLO.K * (PFOL.K - PRFOL.K) + PRFOL.K \quad 52, A$$

FOL - FOOD OUTPUT PER LABORER (RIALS/YEAR/PERSON)  
MFOLO - MULTIPLIER FOR FOOD OUTPUT PER LABORER FROM OIL AVAILABILITY (DIMENSIONLESS)  
PFOL - POTENTIAL FOOD OUTPUT PER LABORER (RIALS/YEAR/PERSON)  
PRFOL - PRIMITIVE FOOD OUTPUT PER LABORER (RIALS/YEAR/PERSON)

The primitive food output per laborer PRFOL, Equation 53, equals primitive food output per laborer normal PRFOLN when land per laborer in the agricultural sector is equal to the land-labor ratio normal LLRN. Primitive food output per laborer normal PRFOLN is assumed to be 30,000 rials per laborer per year at 1972 prices. The land-labor ratio normal is taken as 2.52 hectares per worker which is equal to the cropped land per worker in 1971. The agricultural land LAND, taken to be constant in the model, is set at

9,271,000 hectares, which was the amount of cropped land in Iran in 1971 according to Oddvar Aresvik (1976), p. 248. When land per labor in agriculture becomes less than the land-labor ratio normal LLRN, primitive food output per laborer PRFOL drops below primitive food output per laborer normal PRFOLN. Figure A.7 illustrates the functional relationship between  $(PRFOL/PRFOLN)$  and the ratio of land to labor in the agricultural sector. As the ratio of land to labor in the agricultural sector increases, so does primitive food output per laborer PRFOL, but with a diminishing rate.

Multiplier for food output per laborer from oil availability MFOLO, Equation 54, is a function of oil availability indicator OAI. Figure A.8 shows the functional relationship assumed between MFOLO and OAI in the model. As shown in Figure A.8, when OAI is greater than one, indicating that the desired oil for the operation of the economy is available and there is no oil shortage, MFOLO is one. As OAVI falls below one, MFOLO also drops.

For values of OAVI less than 1, the estimation of an accurate value for MFOLO may be very hard and is not within the scope of this study. However, the lack of accurate information about the values of MFOLO does not imply that MFOLO should be excluded from the model. Instead, different assumptions about the value of MFOLO can be made and the implication of those assumptions for the behavior of the system under alternative policies may be studied. In fact, exclusion of MFOLO from the model implies the assumption that an oil shortage does not have any effect whatsoever on the agricultural output. Such an assumption in Figure A.8 means that the MFOLO curve is horizontal at the value of 1 independent of the value of oil availability

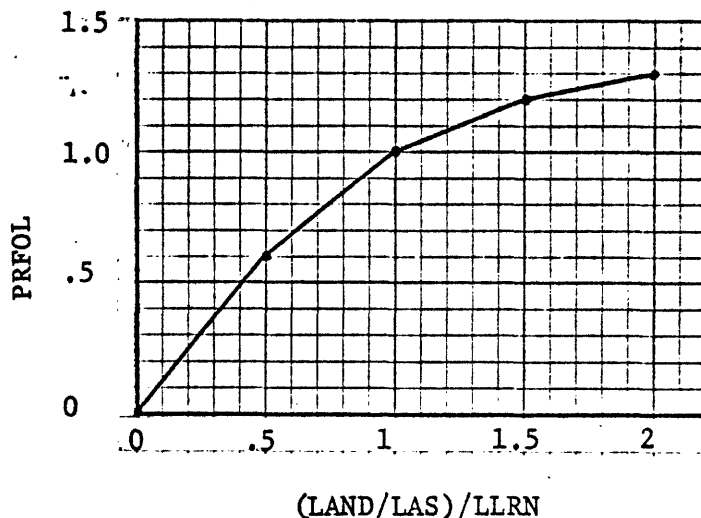

Figure A.7: The Ratio of Primitive Food Output per Laborer to Primitive Food Output per Labor Normal Versus the Land/Labor Ratio to Land/Labor Ratio Normal

```

PRFOL.K=TABHL(TPRFOL, ((LAND/LAS.K)/LLRN), 0, 2, .5) * 53, A
  PRFOLN
TPRFOL=0/.6/1/1.2/1.3 53.1, T
LLRN=2.52 53.2, C
PRFOLN=30000 53.3, C
LAND=9271000 53.4, C
  PRFOL - PRIMITIVE FOOD OUTPUT PER LABORER (RIALS/
          YEAR/PERSON)
  TPRFOL - TABLE FOR PRIMITIVE FOOD OUTPUT PER LABORER
  LAND - AGRICULTURAL LAND (HECTARS)
  LAS - LABOR IN AGRICULTURAL SECTOR (PERSONS)
  LLRN - LAND LABOR RATIO NORMAL (HECTARS/PERSON)
  PRFOLN - PRIMITIVE FOOD OUTPUT PER LABORER NORMAL
          (RIALS/YEAR/PERSON)
    
```

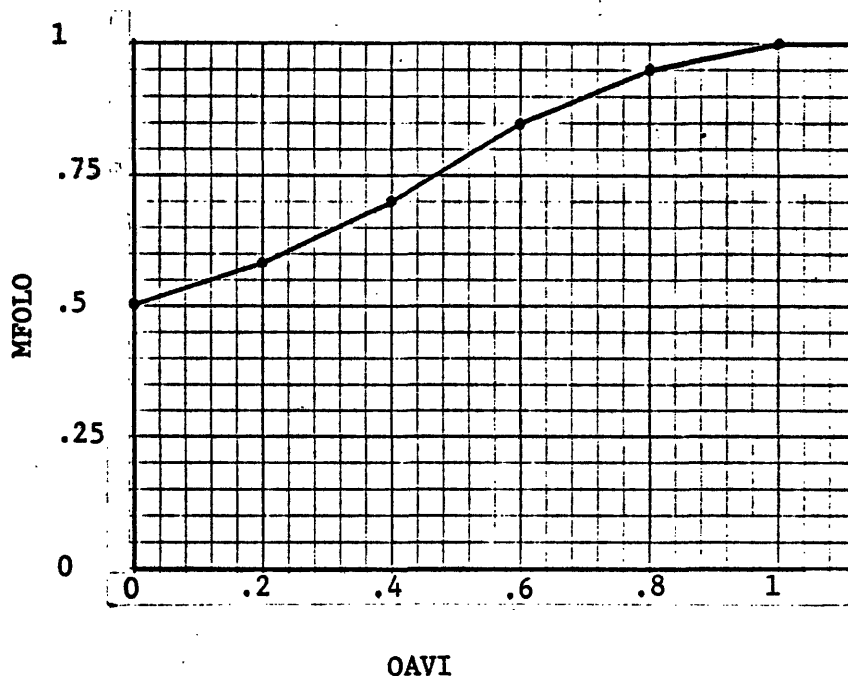

Figure A.8: Multiplier for Food Output per Laborer Versus Oil Availability Indicator

MFOLO.K=TABHL(TMPFO,OAVI.K,0,1,.2) 54, A  
TMPFO=.5/.58/.7/.85/.95/1 54.1, T  
MFOLO - MULTIPLIER FOR FOOD OUTPUT PER LABORER FROM  
OIL AVAILABILITY (DIMENSIONLESS)  
TMPFO - TABLE FOR MULTIPLIER FOR FOOD OUTPUT PER  
LABORER FROM OIL AVAILABILITY  
OAVI - OIL AVAILABILITY INDICATOR (DIMENSIONLESS)

indicator OAVI. A horizontal MFOLO curve implies that when oil reserves are completely depleted and oil availability indicator OAVI is zero, lack of oil as an energy source does not decrease labor productivity in an advanced agriculture. It implies that all the capital equipment in the agricultural



sector will work without oil resources as efficiently as they work with oil. It implies that it is even not necessary to devote some of the production factors to the production of a possible alternative energy source and therefore decreasing the available production factors for food production. But this assumption is very optimistic and probably unrealistic. Even if, within the next two decades, a substitute for oil becomes available which can be produced as easily as oil is currently produced, and even if Iran can import such energy resources or adopt the technology to produce it domestically instead of oil, after then it may take two more decades to replace the stock of capital equipment with mechanaries which use the new energy source.

Another extreme assumption about the relationship between MFOLQ and OAVI is that when OAVI is zero, MFOLQ should also be zero. This assumption implies that when oil resources are completely exhausted and OAVI becomes zero, multiplier for output per laborer from oil MFOLQ will become zero and food output per laborer will decrease to its correspondent value in a primitive society - i.e., primitive food output per laborer. Probably this extreme assumption is unrealistic, too. Even if at a zero oil availability agricultural machinery can not work, agricultural and managerial know-how in an advanced society would increase the agricultural output well above the correspondent output in a primitive society.

Observing that both above extreme assumptions are most probably unrealistic, the assumption used in the model is one which is between the two extremes. As shown in Figure A.8, when oil is completely depleted and oil

availability indicator OAVI is zero, it is assumed that the value of MFOLO is 0.5. As OAVI increases, so does MFOLO. When OAVI becomes greater than one, MFOLO levels off, indicating that oil availability does not constrain agricultural output.

Potential food output per laborer PFOL, in addition to MFOLO, is another determinant of food output per laborer FOL. Potential food output per laborer PFOL, Equation 55, is the ratio of potential food output PFOUT and labor in the agricultural sector.

$$PFOL.K = (PFOUT.K / LAS.K) * 1000000 \quad 55, A$$

PFOL - POTENTIAL FOOD OUTPUT PER LABORER (RIALS/  
YEAR/PERSON)  
PFOUT - POTENTIAL FOOD OUTPUT (1E6 RIALS/YEAR)  
LAS - LABOR IN AGRICULTURAL SECTOR (PERSONS)

Potential food output PFOUT, Equation 56, is determined by a Cobb-Douglas production function augmented by technology in agricultural sector TAS. The production factors are labor, capital, and education in agricultural sector (LAS, CAS, and EAS respectively), and agricultural land. Agricultural land is assumed to be constant in the model and therefore does not appear explicitly in Equation 56. The quantity of land is embodied in the value of the constant in the production function - i.e., food output constant FOUTC.

$$PFOUT.K = FOUTC * (EXP(ELA * LOGN(LAS.K))) * (EXP(ECA * LOGN(CAPAS.K))) * (EXP(EEA * LOGN(EAS.K))) * TAS.K \quad 56, A$$

FOUTC=11.83 56.2, C  
ELA=.45 56.3, C  
EEA=.2 56.4, C  
ECA=.10 56.5, C

PFOUT - POTENTIAL FOOD OUTPUT (1E6 RIALS/YEAR)  
FOUTC - FOOD OUTPUT PRODUCTION FUNCTION CONSTANT  
(1E6 RIALS/YEAR)

EXP	- EXPONENTIAL FUNCTION
ELA	- EXPONENT OF LABOR IN AGRICULTURAL PRODUCTION FUNCTION (DIMENSIONLESS)
LAS	- LABOR IN AGRICULTURAL SECTOR (PERSONS)
ECA	- EXPONENT OF CAPITAL IN AGRICULTURAL PRODUCTION FUNCTION (DIMENSIONLESS)
CAPAS	- CAPITAL IN AGRICULTURAL SECTOR (1E6 RIALS)
EEA	- EXPONENT OF EDUCATION IN AGRICULTURAL PRODUCTION FUNCTION (DIMENSIONLESS)
EAS	- EDUCATION IN AGRICULTURAL SECTOR (1000 MAN- YEARS-OF-SCHOOLING)
TAS	- TECHNOLOGY IN AGRICULTURAL SECTOR (TECHNOLOGY)

The exponents of labor ELA, capital ECA and education EEA in the agricultural production function are set at .5, .15, and .15 respectively. The nature of production activities in the agricultural sector is assumed to be more labor intensive and less capital and education intensive than the production activities in the industrial sector. The exponents of labor, capital, and education in the production function of the industrial sector, which will be discussed later, are 0.4, 0.3 and 0.3 while in the production function of the agricultural sector they are .45, .1, and .2 respectively. The three exponents in the agricultural production function ELA, ECA, and EEA add up to 0.8, indicating a decreasing return to scale in food production with respect to the three production factors labor, capital, and education in the agricultural sector. Because agricultural land is limited, at a given level of technology, a proportional rise in the three production factors (labor, capital, and education) is assumed not to increase the food production proportionally.

The value of food output constant FOUTC, the constant coefficient in Equation 56, is set at 4.64. FOUTC is determined by substituting the value of

production factors in the agricultural sector as well as the agricultural output in Equation 56 for 1959. Potential food output PFOUT is set equal to actual agricultural output in 1959, 140,700 million rials at 1972 constant prices. Labor, capital, and education in the agricultural sector in 1959 were 3,417,000 persons, 70,500 million 1972 constant rials, and 1780 thousand man-years of schooling, respectively. Technology in agricultural sector TAS, which is an agricultural technology index, is set equal to one in 1959. Therefore, FOUTC will be:

$$FOUTC = \frac{140,700}{(3,417,000)^{0.5}(70,500)^{0.15}(1780)^{0.15}(1)} = 4.64$$

Using Equation 56, the simulation of the model from 1959 to 1974 generates a food output fairly close to the actual agricultural output during that period. The above rough approximation of the constant values in Equation 56 seems sufficient for the purpose of this study. A more accurate estimation of these constant values requires an extensive effort, especially when the accuracy of the available data is poor. Such effort is neither within the scope of this study nor justified for its purpose, which is to understand the dynamics of the Iranian economy during the next two or three decades, rather than a point by point prediction of the future. Different simulations have shown that the dynamics of the system is insensitive to a reasonable variation of the values of constant in the agricultural production function.

In this section of the model, marginal productivities of different production factors in the agricultural sectors are also determined. If there

is no oil shortage to reduce the food production, food output FOUT will be equal to potential food output PFOUT, and marginal productivity of each factor in agriculture will be the derivative of PFOUT with respect to that factor. The derivative of PFOUT, in Equation 56, with respect to each production factor, equals:

$$\frac{(\text{Exponent of the factor})(\text{PFOUT})}{(\text{The amount of factor in the agricultural sector})}$$

However, when an oil shortage exists, food output drops below the potential food output PFOUT and marginal productivity of each factor decreases. If we assume that the drop in marginal productivity of each factor is proportional to the drop in PFOUT, then:

$$\begin{aligned} \text{Marginal productivity of each factor} &= \frac{(\text{Exponent of the factor})(\text{PFOUT})}{(\text{Factor in agricultural sector})} \cdot \frac{\text{FOUT}}{\text{PFOUT}} \\ &= \frac{(\text{Exponent of the factor})(\text{FOUT})}{(\text{Factor in agricultural sector})} \end{aligned}$$

Based on the above formula, marginal productivities of labor, capital, and education in agricultural sector MPLAS, MPCAS, and MPEAS, respectively, are determined in Equations 57, 58, and 59.

$$\text{MPLAS.K} = (\text{ELA}/\text{LAS.K}) * \text{FOUT.K}$$

57, A

- MPLAS - MARGINAL PRODUCTIVITY OF LABOR IN AGRICULTURAL SECTOR (1E6 RIALS/YEAR/PERSON)
- ELA - EXPONENT OF LABOR IN AGRICULTURAL PRODUCTION FUNCTION (DIMENSIONLESS)
- LAS - LABOR IN AGRICULTURAL SECTOR (PERSONS)
- FOUT - FOOD OUTPUT (1E6 RIALS/YEAR)

$MPCAS.K = (ECA/CAPAS.K) * FOUT.K$  58, A  
MPCAS - MARGINAL PRODUCTIVITY OF CAPITAL IN  
AGRICULTURAL SECTOR (1E6 RIALS/YEAR/1E6  
RIALS)  
ECA - EXPONENT OF CAPITAL IN AGRICULTURAL  
PRODUCTION FUNCTION (DIMENSIONLESS)  
CAPAS - CAPITAL IN AGRICULTURAL SECTOR (1E6 RIALS)  
FOUT - FOOD OUTPUT (1E6 RIALS/YEAR)

$MPEAS.K = (EEA/EAS.K) * FOUT.K$  59, A  
MPEAS - MARGINAL PRODUCTIVITY OF EDUCATION IN  
AGRICULTURAL SECTOR (1E6 RIALS/YEAR/1000  
MAN-YEARS-OF-SCHOOLING)  
EEA - EXPONENT OF EDUCATION IN AGRICULTURAL  
PRODUCTION FUNCTION (DIMENSIONLESS)  
EAS - EDUCATION IN AGRICULTURAL SECTOR (1000 MAN-  
YEARS-OF-SCHOOLING)  
FOUT - FOOD OUTPUT (1E6 RIALS/YEAR)

### A.3 PRODUCTION CAPACITY IN THE INDUSTRIAL SECTOR

Production capacity in the industrial sector PCIS, Equation 61, is equal to labor in the industrial sector LIS times production capacity per laborer in the industrial sector PCLI.

$PCIS.K = (LIS.K * PCLI.K) / 1000000$  61, A  
PCIS - PRODUCTION CAPACITY IN INDUSTRIAL SECTOR  
(1E6 RIALS/YEAR)  
LIS - LABOR IN INDUSTRIAL SECTOR (PERSONS)  
PCLI - PRODUCTION CAPACITY PER LABORER IN  
INDUSTRIAL SECTOR (RIALS/YEAR/PERSON)

Production capacity per laborer in the industrial sector PCLI, Equation 62, is based on potential production capacity per laborer in the industrial sector PPCLI, primitive production capacity per laborer in the industrial sector PRPCLI, and multiplier for production capacity per laborer

in industry from oil availability MPCLIO. When the value of MPCLIO is one, indicating that the desired oil for the operation of the economy is available, PCLI is the same as PPCLI. As MPCLIO becomes less than one, indicating an effect of the existence of an oil shortage, PCLI drops below PPCLI and towards the primitive production capacity per laborer in the industrial sector PRPCLI. The intensity of the effect of an oil shortage on the production capacity per laborer in the industrial sector PCLI depends on the difference between PPCLI and PRPCLI. If the potential production capacity per laborer in the industrial sector PPCLI is the same as the primitive production capacity per laborer in the industrial sector PRPCLI - i.e., the industrial sector is at a primitive level - an oil shortage does not affect the production capacity of the industrial sector. The greater the difference between PPCLI and PRPCLI, the more advanced and capital intensive the economy is, and the greater the effect of an oil shortage will be on the production capacity per laborer in the industrial sector and therefore on industrial output.

$$\begin{aligned} PCLI.K &= MPCLIO.K * (PPCLI.K - PRPCLI) + PRPCLI && 62, A \\ PRPCLI &= 30000 && 62.1, C \end{aligned}$$

- PCLI - PRODUCTION CAPACITY PER LABORER IN INDUSTRIAL SECTOR (RIALS/YEAR/PERSON)
- MPCLIO - MULTIPLIER FOR PRODUCTION CAPACITY PER LABORER IN INDUSTRY FROM OIL AVAILABILITY (DIMENSIONLESS)
- PPCLI - POTENTIAL PRODUCTION CAPACITY PER LABORER IN INDUSTRIAL SECTOR (1E6 RIALS/PERSON/YEAR)
- PRPCLI - PRIMITIVE PRODUCTION CAPACITY PER LABORER IN INDUSTRIAL SECTOR (RIALS/YEAR/PERSON)

The primitive production capacity per laborer in industrial sector PRPLIS is assumed to be 30,000 rials per year per laborer. The value of

PRPLIS is the same as the value assumed for primitive food output per laborer in the agricultural sector in the previous section.

Multiplier for production capacity per laborer in industry from oil MPCLIO, Equation 62, is a function of oil availability indicator OAVI. Figure A.9 shows the functional relationship assumed between MPCLIO and OAI in the model. The relationship between MPCLIO and OAI is the same as the relationship between the multiplier for food output per laborer from oil availability MFOLO and OAVI, explained in Section A.2 and shown in Figure A.8. When oil availability indicator OAI is zero, MPCLIO is assumed to be 0.5. As OAVI increases from zero to one, MPCLIO rises from 0.5 and levels off at 1.

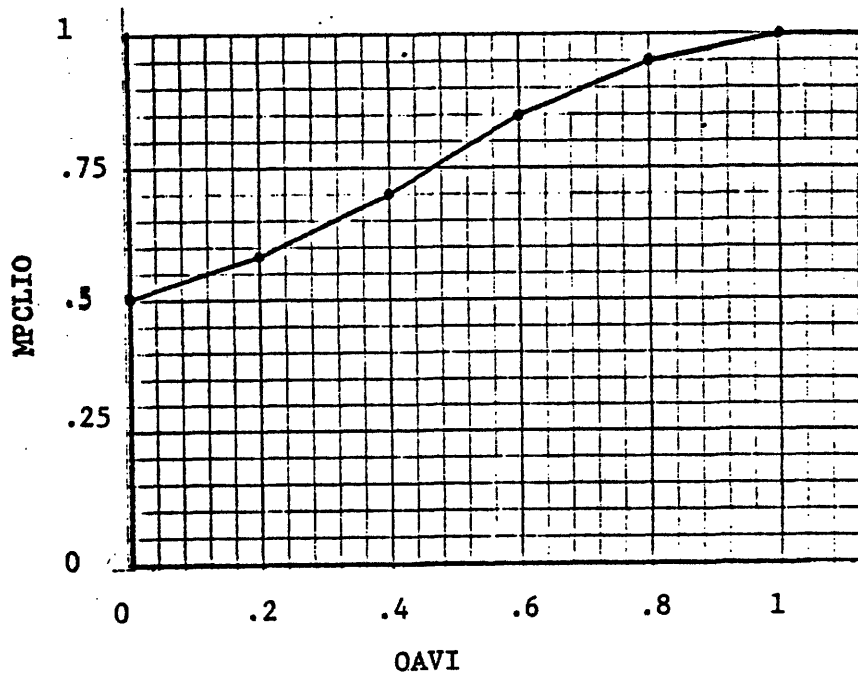

Figure A.9: Multiplier for Production Capacity per Laborer in Industry from Oil Availability Versus Oil Availability Indicator



MPCLIO.K=TABHL(TMPCI,OAVI.K,0,1,.2) 63, A  
TMPCI=.5/.58/.7/.85/.95/1 63.1, T  
MPCLIO - MULTIPLIER FOR PRODUCTION CAPACITY PER  
LABORER IN INDUSTRY FROM OIL AVAILABILITY  
(DIMENSIONLESS)  
TMPCI - TABLE FOR MULTIPLIER FOR PRODUCTION  
CAPACITY PER LABORER IN INDUSTRY FROM OIL  
AVAILABILITY  
OAVI - OIL AVAILABILITY INDICATOR (DIMENSIONLESS)

Potential production capacity per laborer in the industrial sector  
PPCLI, Equation 64, is the ratio of potential production capacity in the  
industrial sector PPCIS and labor in the industrial sector LIS.

PPCLI.K=(PPCIS.K/LIS.K)\*1000000 64, A  
PPCLI - POTENTIAL PRODUCTION CAPACITY PER LABORER  
IN INDUSTRIAL SECTOR (1E6 RIALS/PERSON/  
YEAR)  
PPCIS - POTENTIAL PRODUCTION CAPACITY IN INDUSTRIAL  
SECTOR (1E6 RIALS/ YEAR)  
LIS - LABOR IN INDUSTRIAL SECTOR (PERSONS)

Potential production capacity in the industrial sector PPCIS,  
Equation 65, is determined by a Cobb-Douglas production function and  
technology in the industrial sector TIS. The production factors are labor,  
capital, and education in the industrial sector LIS, CIS, AND EIS,  
respectively.

PPCIS.K=PCIC\*(EXP(ELI\*LOGN(LIS.K)))(EXP(ECI\* 65, A  
LOGN(CAPIS.K)))(EXP(EEI\*LOGN(EIS.K)))\*TIS.K  
PCIC=.824 65.2, C  
ELI=.4 65.3, C  
ECI=.3 65.4, C  
EEI=.3 65.5, C  
PPCIS - POTENTIAL PRODUCTION CAPACITY IN INDUSTRIAL  
SECTOR (1E6 RIALS/ YEAR)  
PCIC - PRODUCTION CAPACITY IN INDUSTRIAL SECTOR  
CONSTANT (1E6 RIALS/YEAR)  
EXP - EXPONENTIAL FUNCTION  
ELI - EXPONENT OF LABOR IN INDUSTRIAL PRODUCTION  
FUNCTION (DIMENSIONLESS)

LIS - LABOR IN INDUSTRIAL SECTOR (PERSONS)  
ECI - EXPONENT OF CAPITAL IN INDUSTRIAL  
PRODUCTION FUNCTION (DIMENSIONLESS)  
CAPIS - CAPITAL IN INDUSTRIAL SECTOR (1E6 RIALS)  
EEI - EXPONENT OF EDUCATION IN INDUSTRIAL  
PRODUCTION FUNCTION (DIMENSIONLESS)  
EIS - EDUCATION IN INDUSTRIAL SECTOR (1000 MAN-  
YEARS-OF-SCHOOLING)  
TIS - TECHNOLOGY IN INDUSTRIAL SECTOR  
(TECHNOLOGY)

For the purpose of this model, a rough estimation of the exponents in the production function is sufficient. The dynamics of the model is not sensitive to the variation of these exponents within a reasonable range. The exponents of the different production factors in Equation 65 are determined based on two assumptions. The first assumption is that the exponents of production factors in Iran and an advanced market economy such as the United States are the same. This first assumption simply says that at an equal technology level in the two countries with the same combination of factors, marginal productivity of each factor will be the same. The second assumption is that in the U.S., as a country with almost a competitive market economy, the exponent of each production factor in the Cobb-Douglas production function is equal to the share of that factor in the total output. This second assumption is in accordance with the theory of efficient allocation of output in a competitive market economy.

In the United States, according to Denison (1962) p.30, the average share of return to capital in output has been about 30 per cent from 1909-1958. During the same period, the share of labor and education embodied

in labor together in the form of labor compensation has been about 70 per cent. The necessary data needed in order to calculate the share of education in total labor compensation are available only for one year, 1949, and are presented in Table A.6. Table A.6 contains data on the number of labor force in different age groups, and mean income of uneducated people in each category. Using these data, employee's compensation based on the wage rates of uneducated labor force is determined in Column 4 of Table A.6. The total compensation based on the wage rate of uneducated people is 78,935.1 million dollars. However, the actual compensation in 1949 was 141,000 million dollars (Historical Statistics of the United States, 1975, p. 235). Therefore, the share of education in total compensation of employees is:

$$\begin{aligned} & \frac{(\text{Total Employees' Compensation}) - (\text{Compensation Based on Wage Rate of Illiterates})}{\text{Total Employees' Compensation}} \\ & = \frac{141,000 - 78,935.1}{141,000} = 0.44 \end{aligned}$$

Therefore, the share of education in total output has been  $0.44 \times 0.7 = 0.30$ .

The share of labor excluding education, therefore, has been  $0.7 - 0.3 = 0.4$ .

In Equation 65, the exponents of labor, capital, and education in the industrial sector ELI, ECI, and EEI, respectively, are set at 0.4, 0.3, and 0.3, which are the approximate shares of labor, capital and education in the total output, respectively.

Production capacity in the industrial sector constant PCIC - i.e., the constant coefficient in Equation 65, is equal to 0.824. The value of PCIC

Table A.6

Mean Income of Uneducated Workers and Total  
Labor Force by Age Group in the U.S. in 1949

<u>Age Group</u>	<u>Mean Income Before Taxes for Those With No Education (in \$/year)</u>	<u>Labor Force in Different Age Groups (in persons)</u>	<u>Income of Labor Force in Each Group With Wage Rate Equal to Those With 0 Years of Schooling (\$10<sup>5</sup>)</u>
(1)	(2)	(3)	(4)
16-19	314.0	4,712	1,479.6
20-24	723.5	7,860	5,686.7
25-44	1,267.0	28,745	36,420.0
45-64	1,725.0	18,576	32,052.0
65 & over	1,095.0	3,010	3,295.9
<hr/>	<hr/>	<hr/>	<hr/>
Total		62,903	78,935.1

Sources: Column (2) is based on data in H.S. Houthakker (1959), p.25.  
Column (3) is based on data from Historical Statistics of the  
United States (1975), p. 131.

is set such that when the simulation of the model starts in 1959, the value of industrial output in the model in 1959 becomes close to the actual industrial output in that year.

Oil availability indicator OAVI, which influences the production capacity of the industrial sector, is based on oil reserves OIL, domestic

demand for energy DDE, and normal reserves coverage time NRC. NRC is taken as 15 years. According to the WAES report (1977), p.116, 15 years is a reasonable coverage time before oil reserves restrict oil production.

$$\text{OAVI.K} = (\text{OIL.K} / \text{DDE.K}) / \text{NRC} \quad 66, \text{ A}$$

NRC=15 66.1, C

OAVI - OIL AVAILABILITY INDICATOR (DIMENSIONLESS)  
OIL - OIL RESERVES (1E9 BARRELS)  
DDE - DOMESTIC DEMAND FOR ENERGY (1E9 BARRELS OF OIL/YEAR)  
NRC - NORMAL RESERVES COVERAGE TIME (YEARS)

Domestic demand for energy DDE, Equation 67, is equal to demand for energy per non-oil output DEPNO times potential non-oil output PNOO.

$$\text{DDE.K} = (\text{DEPNO.K} * \text{PNOO.K}) / 1E9 \quad 67, \text{ A}$$

DDE - DOMESTIC DEMAND FOR ENERGY (1E9 BARRELS OF OIL/YEAR)  
DEPNO - DEMAND FOR ENERGY PER NON-OIL OUTPUT (BARRELS OF OIL/1E6 RIALS )  
PNOO - POTENTIAL NON-OIL OUTPUT (1E6 RIALS/YEAR)

Demand for energy per non-oil output DEPNO, Equation 68, is a function of potential non-oil output per capita PNOPC. Figure A.10 illustrates the functional relationship between DEPNO and PNOPC. In the same figure, twenty points represent energy consumption per output and GNP per capita for 18 different countries.

As shown in Figure A.10, when potential non-oil output per capita PNOPC is zero, so is demand for energy per non-oil output DEPNO. When PNOPC is close to zero, indicating a very primitive society, DEPNO is also close to zero. As PNOPC increases, so does DEPNO. When potential non-oil output per capita PNOPC becomes more than 75,000 rials/year, as the data points suggest,

DEPNO levels off at the value of 120 barrels of oil per one million rials of output per year.

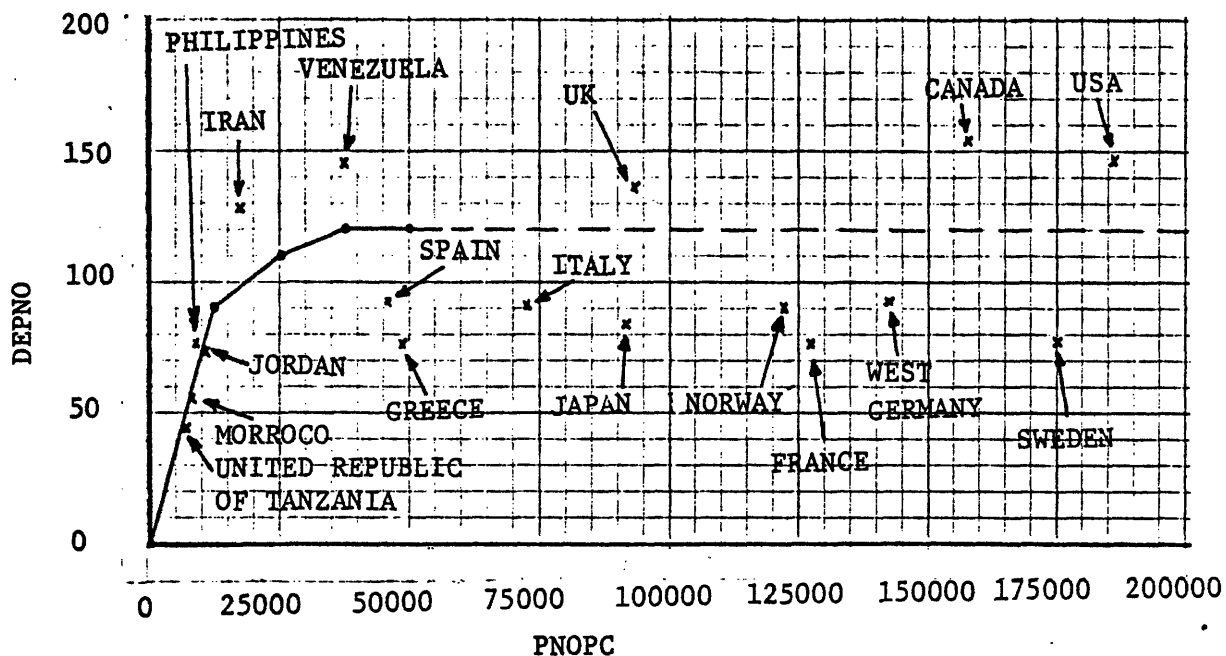

Figure A.12: Demand for Energy per Non-Oil Output Versus Potential Non-Oil Output per Capita.

Sources: (1) United Nations Yearbook of National Account Statistics 1975.  
 (2) United Nations, Statistical Yearbook 1973.

Note: Data points are for 1972.

DEPNO.K=TABHL(TDEPNO,PNOPC.K,0,100000,25000) 68, A  
 TDEPNO=0/90/110/120/120 68.1, T  
 DEPNO - DEMAND FOR ENERGY PER NON-OIL OUTPUT  
 (BARRELS OF OIL/10<sup>6</sup> RIALS )  
 TDEPNO - TABLE FOR DEMAND FOR ENERGY PER NON-OIL  
 OUTPUT  
 PNOPC - POTENTIAL NON-OIL OUTPUT PER CAPITA (10<sup>6</sup>  
 RIALS/YEAR/PERSON)

Potential non-oil output per capita PNOPC, Equation 69, is the ratio of potential non-oil output PNOO and population POP.

$$\text{PNOPC.K} = (\text{PNOO.K} * 1000000) / (\text{POP.K}) \quad 69, A$$

PNOPC - POTENTIAL NON-OIL OUTPUT PER CAPITA (1E6 RIALS/YEAR/PERSON)  
PNOO - POTENTIAL NON-OIL OUTPUT (1E6 RIALS/YEAR)  
POP - POPULATION (PERSONS)

Potential non-oil output PNOO, Equation 70, is the summation of potential production capacity in the industrial sector PPCIS and potential food output PFOUT.

$$\text{PNOO.K} = \text{PPCIS.K} + \text{PFOUT.K} \quad 70, A$$

PNOO - POTENTIAL NON-OIL OUTPUT (1E6 RIALS/YEAR)  
PPCIS - POTENTIAL PRODUCTION CAPACITY IN INDUSTRIAL SECTOR (1E6 RIALS/ YEAR)  
PFOUT - POTENTIAL FOOD OUTPUT (1E6 RIALS/YEAR)

This section of the model also determines marginal productivity of each factor in the industrial sector. If industrial output was equal to PPCIS, the marginal productivity of each factor in the industrial sector would be the derivative of PPCIS with respect to that factor. The derivative of PPCIS, in Equation 65, with respect to each production factor, equals:

$$\frac{(\text{Exponent of the factor}) (\text{PPCIS})}{(\text{The amount of factor in the industrial sector})}$$

However, low productivity in the new industries due to lack of experience, possible shortage of intermediate goods and the resultant idle capacity, or a possible energy shortage can decrease the industrial output IOU below PPCIS.

If we assume that the drop in marginal productivity of each factor is proportional to the drop in PPCIS, then:

(Marginal productivity of each factor in industrial sector) =

$$\frac{(\text{Exponent of the factor}) (\text{PPCIS})}{(\text{Amount of factor in industrial sector})} \cdot \frac{\text{IOUT}}{\text{PPCIS}}$$
$$= \frac{(\text{Exponent of the factor}) (\text{IOUT})}{(\text{Amount of factor in industrial sector})}$$

Based on the above formula, marginal productivity of labor in the industrial sector MPLIS, marginal productivity of capital in the industrial sector MPCIS, and marginal productivity of education in industrial sector MPEIS are determined in Equations 71, 72, and 73, respectively.

$$\text{MPLIS.K} = (\text{ELI}/\text{LIS.K}) * \text{IOUT.K} \quad 71, \text{ A}$$

MPLIS - MARGINAL PRODUCTIVITY OF LABOR IN INDUSTRIAL SCETOR (1E6 RIALS /YEAR/ PERSON)

ELI - EXPONENT OF LABOR IN INDUSTRIAL PRODUCTION FUNCTION (DIMENSIONLESS)

LIS - LABOR IN INDUSTRIAL SECTOR (PERSONS)

IOUT - INDUSTRIAL OUTPUT (1E6 RIALS/YEAR)

$$\text{MPCIS.K} = (\text{ECI}/\text{CAPIS.K}) * \text{IOUT.K} \quad 72, \text{ A}$$

MPCIS - MARGINAL PRODUCTIVITY OF CAPITAL IN INDUSTRIAL SECTOR (1E6 RIALS/YEAR/1E6 RIALS)

ECI - EXPONENT OF CAPITAL IN INDUSTRIAL PRODUCTION FUNCTION (DIMENSIONLESS)

CAPIS - CAPITAL IN INDUSTRIAL SECTOR (1E6 RIALS)

IOUT - INDUSTRIAL OUTPUT (1E6 RIALS/YEAR)

$$\text{MPEIS.K} = (\text{EEI}/\text{EIS.K}) * \text{IOUT.K} \quad 73, \text{ A}$$

MPEIS - MARGINAL PRODUCTIVITY OF EDUCATION IN INDUSTRIAL SECTOR (1E6 RIALS/YEAR/1000 MAN-YEARS-OF-SCHOOLING)

EEI - EXPONENT OF EDUCATION IN INDUSTRIAL PRODUCTION FUNCTION (DIMENSIONLESS)

EIS - EDUCATION IN INDUSTRIAL SECTOR (1000 MAN-YEARS-OF-SCHOOLING)

IOUT - INDUSTRIAL OUTPUT (1E6 RIALS/YEAR)



Industrial output IOUT, Equation 74, is equal to the sum of the value added in the consumption goods sector VACON, the value added in the capital goods sector VACAP, the output of the intermediate goods sector OUTI, and the production capacity in the education PCE, which represents the value added in the education sector.

$$\text{IOUT.K} = \text{VACON.K} + \text{VACAP.K} + \text{OUTI.K} + \text{PCE.K} \quad 74, A$$

IOUT - INDUSTRIAL OUTPUT (1E6 RIALS/YEAR)  
VACON - VALUE ADDED IN CONSUMPTION GOODS SECTOR (1E6 RIALS/YEAR)  
VACAP - VALUE ADDED IN CAPITAL GOODS SECTOR (1E6 RIALS/YEAR)  
OUTI - OUTPUT OF INTERMEDIATE GOODS SECTOR (1E6 RIALS/YEAR)  
PCE - PRODUCTION CAPACITY IN EDUCATION SECTOR (1E6 RIALS/YEAR)

#### A.4 CONSUMPTION GOODS SECTOR

The output of the consumption goods sector OUTCON is value added plus intermediate goods utilized in the sector. OUTCON, Equation 76, is equal to value added in consumption goods sector VACON times one plus intermediate goods value added ratio in consumption goods sector IVARCO.

$$\text{OUTCON.K} = \text{VACON.K} * (1 + \text{IVARCO.K}) \quad 76, A$$

OUTCON - OUTPUT OF CONSUMPTION GOODS SECTOR (1E6 RIALS/YEAR)  
VACON - VALUE ADDED IN CONSUMPTION GOODS SECTOR (1E6 RIALS/YEAR)  
IVARCO - INTERMEDIATE-GOODS VALUE ADDED RATIO IN CONSUMPTION GOODS SECTOR (DIMENSIONLESS)

The intermediate goods value added ration in consumption goods sector IVARCO, Equation 77, is a function of the ratio of production capacity in the consumption goods sector PPCON and population POP. Figure A.11 depicts the

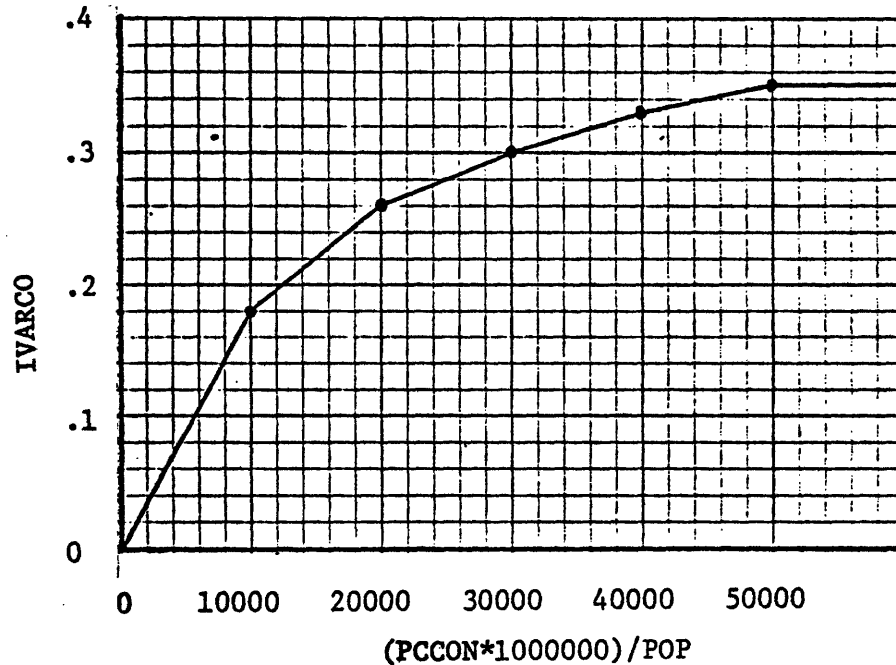

Figure A.11: Intermediate Goods Value Added Ratio for Consumption Goods Versus Production Capacity in Consumption Goods per Population.

```

IVARCO.K=TABHL(TIVARC,((PCCON.K*1000000)/POP.K),0, 77, A
50000,10000)
TIVARC=0/.18/.26/.30/.33/.35 77.1, T
IVARCO - INTERMEDIATE-GOODS VALUE ADDED RATIO IN
CONSUMPTION GOODS SECTOR (DIMENSIONLESS)
TIVARC - TABLE FOR INTERMEDIATE-GOODS VALUE ADDED
RATIO IN CONSUMPTION GOODS SECTOR
PCCON - PRODUCTION CAPACITY IN CONSUMPTION GOODS
SECTOR (1E6 RIALS/YEAR)
POP - POPULATION (PERSONS)
    
```

functional relationship. As production capacity in consumption goods per population increases, so does IVARCO. In one extreme, when (PCCON/POP) is zero, indicating a very primitive society, IVARCO is also zero. In such a primitive society, the production activities are simple, without input-output relation between different activities. As a country develops, its (PCCON/POP)

rises; industrialization takes place and the share of manufacturing in total output increases; satisfaction, complexity of production activities and input-output relationships between them increase; the use of intermediate goods in each unit of output of the sector rises. As a result, IVARCO in the country increases when (PCCON/POP) rises.

The rise of IVARCO, as shown in Figure A.11, diminishes as (PCCON/POP) increases. Because as the production capacity of the sector per population (PPCON/POP) increases, the rise in the share of manufacturing, with a high intermediate goods content, relative to services, with a low intermediate goods content, slows down. As a result, the rise in the overall intermediate goods value added ratio in consumption goods sector IVARCO diminishes. In Figure A.11, IVARCO is assumed to level off at 0.35 when (PPCON/POP) reaches 50,000 rials/person.

Value added in the consumption goods sector VACON, Equation 78, is equal to production capacity in the consumption goods sector PCCON times the utilization factor in the consumption goods sector UFCO.

$$\text{VACON.K} = \text{PCCON.K} * \text{UFCO.K} \quad 78, A$$

VACON - VALUE ADDED IN CONSUMPTION GOODS SECTOR  
(1E6 RIALS/YEAR)

PCCON - PRODUCTION CAPACITY IN CONSUMPTION GOODS  
SECTOR (1E6 RIALS/YEAR)

UFCO - UTILIZATION FACTOR IN CONSUMPTION GOODS  
SECTOR (DIMENSIOLESS)

Utilization factor in the consumption goods sector UFCO, Equation 79, is equal to the product of utilization factor in the consumption goods sector from demand UFCOD and utilization factor in the consumption goods sector from intermediate goods availability UFCOIA.

UFCO.K=UFCOD.K\*UFCOIA.K 79, A  
UFCO - UTILIZATION FACTOR IN CONSUMPTION GOODS  
SECTOR (DIMENSIONLESS)  
UFCOD - UTILIZATION FACTOR IN CONSUMPTION GOODS  
SECTOR FROM DEMAND (DIMENSIONLESS)  
UFCOIA - UTILIZATION FACTOR IN CONSUMPTION-GOODS  
SECTOR FROM INTERMEDIATE-GOODS  
AVAILABILITY (DIMENSIONLESS)

Utilization factor in the consumption goods sector from intermediate goods availability UFCOIA, Equation 80, is a function of the availability of intermediate goods AVIG. Figure A.12 illustrates the functional relationship between UFCOIA and AVIG. All production activities in a modern economy use some kind of intermediate goods. If no intermediate goods are available to be used in the production activities, the activities can not be carried out. In Figure A.12, when the availability of intermediate goods AVIG is zero, UFCOIA is set at zero, indicating that no output is produced in the consumption goods sector. As AVIG increases above zero, so does UFCOIA. If the availabilities of all items of intermediate goods were the same, UFCOIA would change proportional to AVIG. However, the availabilities of different goods are not the same. AVIG indicates the average of various availabilities of different intermediate goods. Therefore, as AVIG increases above zero, UFCOIA increases less than proportional to AVIG. When AVIG is 0.25, UFCOIA is set at 0.15 in Figure A.12. As the least available intermediate goods items become more available and AVIG rises above its very low values (say, values between 0 to 0.25), UFCOIA increases quickly. Since AVIG equals .5 and .75, the values of UFCOIA are set at .5 and .85, respectively, as shown in Figure A.12. Finally, when AVIG becomes one, UFCOIA levels off at 1.

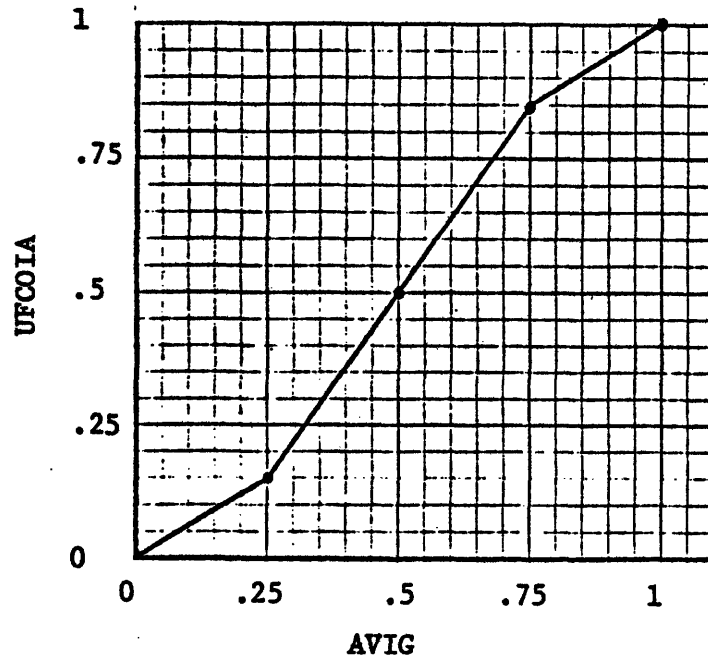

Figure A.12: Utilization Factor in Consumption Goods Sector from Intermediate Goods Availability Versus Availability of Intermediate Goods

UFCOIA.K=TABHL(TUFCO,AVIG.K,0,1,.25) 80, A  
TUFCO=0/.15/.5/.85/1 80.1, T

UFCOIA - UTILIZATION FACTOR IN CONSUMPTION-GOODS  
SECTOR FROM INTERMEDIATE-GOODS  
AVAILABILITY (DIMENSIONLESS)

TUFCO - TABLE FOR UTILIZATION FACTOR IN CONSUMPTION  
GOODS SECTOR FROM INTERMEDIATE GOODS  
AVAILABILITY

AVIG - AVAILABILITY OF INTERMEDIATE GOODS  
(DIMENSIONLESS)

Utilization factor in consumption goods from demand UFCOD, Equation 81, is a function of average availability of consumption goods AAVCO. Figure A.13 shows the functional relationship between UFCOD and AAVCO. When AAVCO is less than one, indicating a high demand for consumption goods, then UFCOD is one. As AAVCO increases above one, indicating inadequate demand for the output of the sector, UFCOD decreases below one. When AAVCO becomes 2, UFCOD is assumed to level off at 0.6.

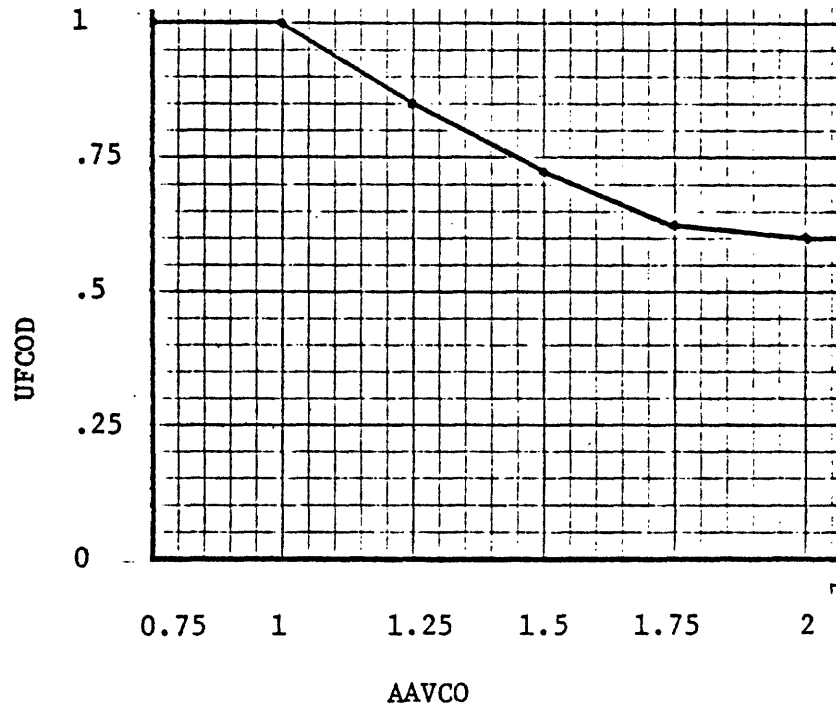

Figure A.13: Utilization Factor in the Consumption Goods Sector from Demand Versus Average Availability of Consumption Goods.

```
UFCOD.K=TABHL(TUFCOD,AAVCO.K,.75,2,.25)           81, A
TUFCOD=1/1/.85/.72/.63/.6                         81.1, T
  UFCOD  - UTILIZATION FACTOR IN CONSUMPTION GOODS
            SECTOR FROM DEMAND (DIMENSIONLESS)
  TUFCOD - TABLE FOR UTILIZATION FACTOR IN CONSUMPTION
            GOODS SECTOR FROM DEMAND
  AAVCO  - AVERAGE AVAILABILITY OF CONSUMPTION GOODS
            (DIMENSIONLESS)
```

Average availability of consumption goods AAVCO, Equation 82, is a smooth function of availability of consumption goods AVCO. Time to average availability of consumption goods TAAVCO, Equation 82.1, is assumed to be one year. And average availability of consumption goods is initialized at 1 in Equation 82.2.

AAVCO.K=SMOOTH(AVCOG.K, TAAVCO) 82, A  
TAAVCO=1 82.1, C  
AAVCO=1 82.2, N  
AAVCO - AVERAGE AVAILABILITY OF CONSUMPTION GOODS  
(DIMENSIONLESS)  
AVCOG - AVAILABILITY OF CONSUMPTION GOODS  
(DIMENSIONLESS)  
TAAVCO - TIME TO AVERAGE AVAILABILITY OF CONSUMPTION  
GOODS (YEARS)

Production capacity in consumption goods sector PCCON, Equation 83, is equal to the potential production capacity in consumption goods PPCON times productivity in consumption goods sector PRCON.

PCCON.K=PPCON.K\*PRCON.K 83, A  
PCCON - PRODUCTION CAPACITY IN CONSUMPTION GOODS  
SECTOR (1E6 RIALS/YEAR)  
PPCON - POTENTIAL PRODUCTION CAPACITY IN  
CONSUMPTION GOODS SECTOR (1E6 RIALS/YEAR)  
PRCON - PRODUCTIVITY IN CONSUMPTION GOODS SECTOR  
(DIMENSIONLESS)

Productivity in the consumption goods sector PRCON, Equation 84, is a function of experience indicator in consumption goods sector EXICON. Figure A.14 shows the functional relationship. When experience indicator EXICON is zero, productivity is assumed to be zero. As EXICON increases, so does PRCON, but with a diminishing rate. When the value of EXICON reaches one, PRCON levels off at one.

Experience indicator in the consumption goods sector EXICON, Equation 85, is the ratio of experience in the consumption goods sector EXCON to

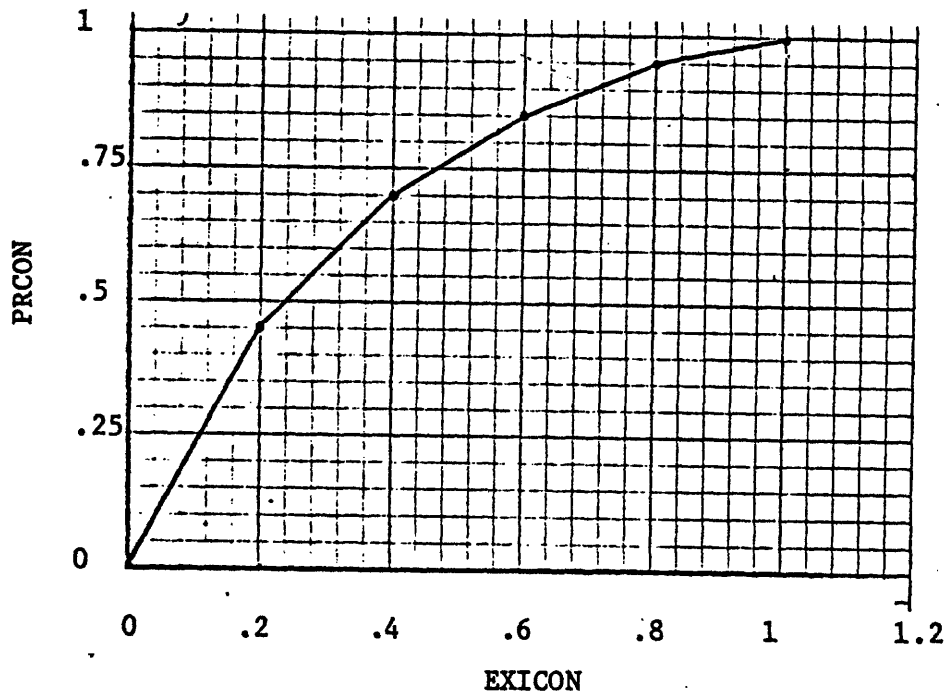

Figure A.14: Productivity in the Consumption Goods Sector Versus Experience Indicator in the Consumption Goods Sector.

```
PRCON.K=TABHL(TPRCO,EXICON.K,0,1,.2)           84, A
TPRCO=0/.45/.70/.85/.95/1                       84.1, T
PRCON - PRODUCTIVITY IN CONSUMPTION GOODS SECTOR
(DIMENSIONLESS)
TPRCO - TABLE FOR PRODUCTIVITY IN CONSUMPTION GOODS
SECTOR
EXICON - EXPERIENCE INDICATOR IN CONSUMPTION GOODS
SECTOR (DIMENSIONLESS)
```



potential production capacity in the consumption goods sector PPCON.

EXICON.K=EXCON.K/PPCON.K 85, A  
EXICON - EXPERIENCE INDICATOR IN CONSUMPTION GOODS  
SECTOR (DIMENSIONLESS)  
EXCON - EXPERIENCE IN CONSUMPTION GOODS SECTOR (1E6  
RIALS/YEAR)  
PPCON - POTENTIAL PRODUCTION CAPACITY IN  
CONSUMPTION GOODS SECTOR (1E6 RIALS/YEAR)

Experience in the consumption goods sector EXCON, Equation 86, is a smooth function of value added in the consumption goods sector. The average time to develop adequate experience in different kinds of activities in the consumption goods sector is assumed to be 5 years, the value assigned to the time to average experience in the consumption goods sector TAEXCO. The experience in consumption goods initial EXCONN is set at 160,000 million 1972 rials per year, 20% lower than value added in the sector in 1959. which was 206,000 million rials at 1972 prices.

EXCON.K=SMOOTH(VACON.K,TAEXCO) 86, A  
TAEXCO=5 86.1, C  
EXCON=EXCONN 86.2, N  
EXCONN=160000 86.3, C  
EXCON - EXPERIENCE IN CONSUMPTION GOODS SECTOR (1E6  
RIALS/YEAR)  
VACON - VALUE ADDED IN CONSUMPTION GOODS SECTOR  
(1E6 RIALS/YEAR)  
TAEXCO - TIME TO AVERAGE EXPERIENCE IN CONSUMPTION  
GOODS SECTOR (YEARS)  
EXCONN - EXPERIENCE IN CONSUMPTION GOODS SECTOR  
INITIAL (1E6 RIALS/YEAR)

The potential production capacity in the consumption goods sector PPCON, Equation 87, is equal to the fraction of production capacity in the

consumption goods sector FPCON times production capacity in the industrial sector PCIS.

$PPCON.K = FPCON.K * PCIS.K$  87, A  
PPCON - POTENTIAL PRODUCTION CAPACITY IN  
CONSUMPTION GOODS SECTOR (1E6 RIALS/YEAR)  
FPCON - FRACTION OF PRODUCTION CAPACITY IN  
CONSUMPTION GOODS SECTOR (DIMENSIONLESS)  
PCIS - PRODUCTION CAPACITY IN INDUSTRIAL SECTOR  
(1E6 RIALS/YEAR)

The fraction of production capacity in consumption goods sector FPCON is equal to the average desired production capacity in consumption goods sector ADPCON divided by the sum of average desired production capacity of all non-agricultural sectors.

$FPCON.K = (ADPCON.K) / (ADPCON.K + ADPI.K + ADPCAP.K + ADPE.K)$  88, A  
FPCON - FRACTION OF PRODUCTION CAPACITY IN  
CONSUMPTION GOODS SECTOR (DIMENSIONLESS)  
ADPCON - AVERAGE DESIRED PRODUCTION CAPACITY IN  
CONSUMPTION GOODS SECTOR (1E6 RIALS/YEAR)  
ADPI - AVERAGE DESIRED PRODUCTION CAPACITY IN  
INTERMEDIATE GOODS SECTOR (1E6 RIALS/  
YEAR)  
ADPCAP - AVERAGE DESIRED PRODUCTION CAPACITY IN  
CAPITAL GOODS SECTOR (1E6 RIALS/YEAR)  
ADPE - AVERAGE DESIRED PRODUCTION CAPACITY IN  
EDUCATION (1EL RIALS/YEAR)

The average desired production capacity in the consumption goods sector ADPCON, Equation 89, is a smoothed value of desired production capacity in the consumption goods sector DPCON. The smooth function is to simulate the necessary long time involved in shifting production capacity from one sector

to another. Therefore, the time to average desired production capacity in the consumption goods sector TAEXCO is set at 20 years. The initial value of average desired production capacity in the consumption goods sector ADPCON is set at 206,000 rials per year, which was value added in the sector in 1959 at 1972 prices.

ADPCON.K=SMOOTH(DPCON.K,TADPCON) 89, A  
TADPCON=20 89.1, C  
ADPCON=200000 89.2, N

ADPCON - AVERAGE DESIRED PRODUCTION CAPACITY IN  
CONSUMPTION GOODS SECTOR (1E6 RIALS/YEAR)  
DPCON - DESIRED PRODUCTION CAPACITY IN CONSUMPTION  
GOODS SECTOR (1E6 RIALS/YEAR)  
TADPCON- TIME TO AVERAGE DESIRED PRODUCTION CAPACITY  
IN CONSUMPTION GOODS SECTOR (YEARS)

The desired production capacity in the consumption goods sector DPCON, Equation 90, is potential production capacity in the consumption goods sector PPCON times three multipliers: multiplier for production capacity in the consumption goods sector from capacity utilization MPCOCU, multiplier for production capacity in the consumption goods sector from productivity MPCOPR, and multiplier for production capacity in the consumption goods sector from availability MPCONA.

DPCON.K=PPCON.K\*MPCONA.K\*MPCOCU.K\*MPCOPR.K 90, A  
DPCON - DESIRED PRODUCTION CAPACITY IN CONSUMPTION  
GOODS SECTOR (1E6 RIALS/YEAR)  
PPCON - POTENTIAL PRODUCTION CAPACITY IN  
CONSUMPTION GOODS SECTOR (1E6 RIALS/YEAR)  
MPCONA - MULTIPLIER FOR PRODUCTION CAPACITY IN  
CONSUMPTION GOODS SECTOR FROM  
AVAILABILITY (DIMENSIONLESS)  
MPCOCU - MULTIPLIER FOR PRODUCTION CAPACITY IN  
CONSUMPTION GOODS SECTOR FROM CAPACITY  
UTILIZATION (DIMENSIONLESS)  
MPCOPR - MULTIPLIER FOR PRODUCTION CAPCITY IN  
CONSUMPTION GOODS SECTOR FROM  
PRODUCTIVITY (DIMENSIONLESS)

The multiplier for production capacity in the consumption goods sector from capacity utilization MPCOCU, Equation 91, is a function of capacity utilization factor in the consumption goods sector UFCO. Figure A.15 depicts the functional relationship between MPCOCU and UFCO. In the extreme of there being no capacity that can be utilized in the consumption goods sector, there will be no desire to allocate any production capacity to that sector. Therefore, when UFCOIA is zero, the value of MPCOCU is also set at zero. As utilization factor UFCOIA increases, so does MPCOCU with a diminishing rate. When the value of UFCOIA becomes one, MPCOCU levels off at value one.

The multiplier for production capacity in the consumption goods sector from productivity MPCOPR, Equation 92, is a function of productivity ratio in the consumption goods sector PRRCO. Figure A.16 shows their functional relationship. In the extreme, when the productivity of production resources in the consumption goods sector is zero, there will be no desire to allocate production capacity to the sector. Therefore, when PRRCO is zero, the value of MPCOPR is also set at zero. As the productivity in the consumption goods sector relative to the other industrial sectors rises, the sector becomes more profitable than the other sectors and the desire to expand the sector increases. Therefore, as PRRCO rises, so does MPCOPR. When PRRCO is one, the productivity in the consumption goods sector is the same as the average productivity in all industrial sectors. Therefore, the effect of productivity on the desired production capacity in the sector is assumed to be

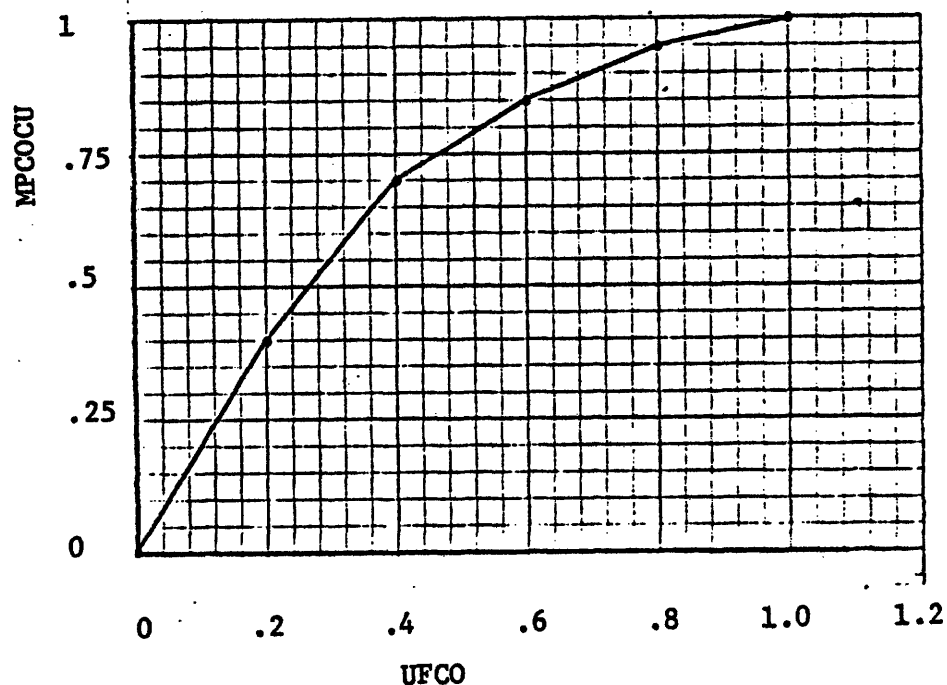

Figure A.15: Multiplier for Production Capacity in the Consumption Goods Sector from Capacity Utilization Versus Utilization Factor in The Consumption Goods Sector.

```
MPCOCU.K=TABHL(TMPCOU,UFCO.K,0,1,.2)          91, A
TMPCOU=0/.4/.7/.85/.95/1                      91.1, T
MPCOCU - MULTIPLIER FOR PRODUCTION CAPACITY IN
          CONSUMPTION GOODS SECTOR FROM CAPACITY
          UTILIZATION (DIMENSIONLESS)
TMPCOU - TABLE FOR MULTIPLIER FOR PRODUCTION CAPCITY
          IN CONSUMPTION SECTOR FROM CAPACITY
          UTILIZATION
UFCO - UTILIZATION FACTOR IN CONSUMPTION GOODS
          SECTOR (DIMENSIOLESS)
```

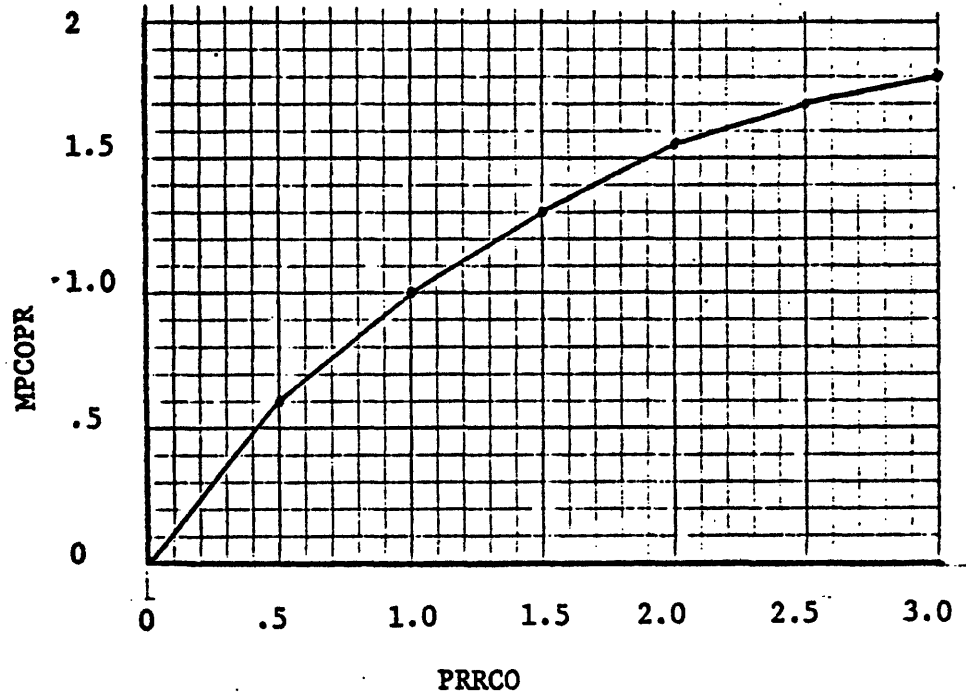

Figure A.16: Multiplier for Production Capacity in the Consumption Goods Sector from Productivity Versus Productivity Ratio in the Consumption Goods Sector.

```
MPCOPR.K=TABHL(TMPCOP,PRRCO.K,0,3,.5)          92, A
TMPCOP=0/.6/1/1.3/1.55/1.7/1.8                92.1, T
MPCOPR - MULTIPLIER FOR PRODUCTION CAPCITY IN
          CONSUMPTION GOODS SECTOR FROM
          PRODUCTIVITY (DIMENSIONLESS)
TMPCOP - TABLE FOR MULTIPLIER FOR PRODUCTION
          CAPACITY IN CONSUMPTION GOODS SECTOR FROM
          PRODUCTIVITY
PRRCO - PRODUCTIVITY RATIO IN CONSUMPTION GOODS
          SECTOR (DIMENSIONLESS)
```

neutral, and MPCOCP is set at one, when PRRCO is one.

As productivity in the sector increases, its incremental effect on the expansion of the sector diminishes. The incremental effect diminishes because investors and planners are uncertain about the market, are afraid from excess

supply due to a large expansion of the sector, and are concerned about the production capacity in the other sectors. On the right hand side of Figure A.16, when the value of PRRCO reaches 3, MPCOPR levels off at 1.8.

The productivity ratio in the consumption goods sector PRRCO, Equation 93, is the ratio of productivity in the consumption goods sector PRCON and the average productivity in industrial sectors APRIS.

$$\text{PRRCO.K} = \text{PRCON.K} / \text{APRIS.K} \quad 93, \text{ A}$$

PRRCO - PRODUCTIVITY RATIO IN CONSUMPTION GOODS SECTOR (DIMENSIONLESS)  
PRCON - PRODUCTIVITY IN CONSUMPTION GOODS SECTOR (DIMENSIONLESS)  
APRIS - AVERAGE PRODUCTIVITY IN INDUSTRIAL SECTOR (DIMENSIONLESS)

The average productivity in industrial sectors APRIS is a weighted average of productivity in the consumption goods sector PRCON, productivity in capital goods sector PRCAP, and productivity in the intermediate goods sector PRI. The weighting coefficients are the fraction of production capacity in different sectors divided by total fraction of production capacity in consumption, capital, and intermediate goods sectors.

$$\text{APRIS.K} = (\text{FPCON.K} * \text{PRCON.K} + \text{FPI.K} * \text{PRI.K} + \text{FPCAP.K} * \text{PRCAP.K}) / (\text{FPCON.K} + \text{FPI.K} + \text{FPCAP.K}) \quad 94, \text{ A}$$

APRIS - AVERAGE PRODUCTIVITY IN INDUSTRIAL SECTOR (DIMENSIONLESS)  
FPCON - FRACTION OF PRODUCTION CAPACITY IN CONSUMPTION GOODS SECTOR (DIMENSIONLESS)  
PRCON - PRODUCTIVITY IN CONSUMPTION GOODS SECTOR (DIMENSIONLESS)  
FPI - FRACTION OF PRODUCTION CAPACITY IN INTERMEDIATE GOODS SECTOR (DIMENSIONLESS)  
PRI - PRODUCTIVITY IN INTERMEDIATE GOODS SECTOR (DIMENSIONLESS)  
FPCAP - FRACTION OF PRODUCTION CAPACITY IN CAPITAL GOODS SECTOR (DIMENSIONLESS)  
PRCAP - PRODUCTIVITY IN CAPITAL GOODS SECTOR (DIMENSIONLESS)

The multiplier for production capacity in the consumption goods sector from availability MPCONA, Equation 95, is a function of availability indicator for consumption goods AVICOG. Figure A.17 shows the functional relationship between MPCONA and AVICOG. When AVICOG is one, the effect of availability on the expansion of the sector is neutral and the value of MPCONA is one. As AVICOG increases, MPCONA decreases, and vice versa. As AVICOG decreases to the very low values, changes in MPCONA diminishes because investors and planners are reluctant to instigate dramatic changes in the capacity of the sector. When the value of AVICOG is zero, the value of MPCONA levels off at 2.6. Similarly, when AVICOG increases to the very high values, levels off at 2.6. Similarly, when AVICOG increases to the very high values,

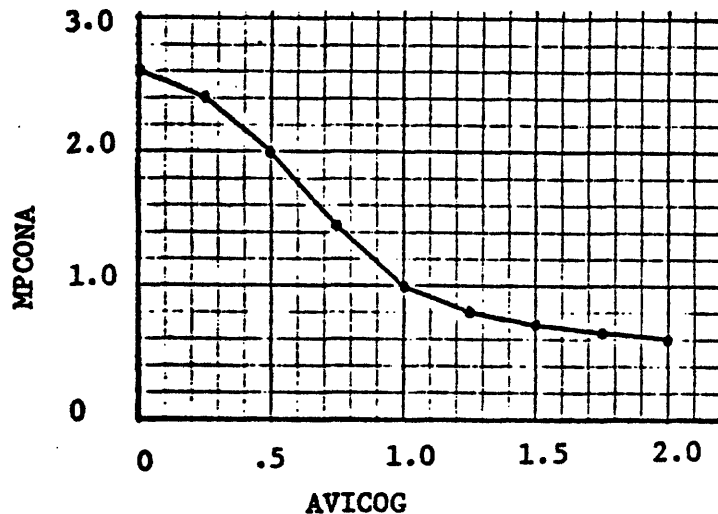

Figure A.17: The Multiplier for Production Capacity in the Consumption Goods Sector from Availability Versus the Availability Indicator for Consumption Goods.



MPCONA.K=TABLE(TMPCOA,AVICOG.K,0,2,.25) 95, A  
TMPCOA=2.6/2.4/2/1.45/1/.8/.7/.64/.60 95.1, T  
MPCONA - MULTIPLIER FOR PRODUCTION CAPACITY IN  
CONSUMPTION GOODS SECTOR FROM  
AVAILABILITY (DIMENSIONLESS)  
TMPCOA - TABLE FOR MULTIPLIER FOR PRODUCTION  
CAPACITY IN CONSUMPTION GOODS SECTOR FROM  
AVAILABILITY  
AVICOG - AVAILABILITY INDICATOR FOR CONSUMPTION  
GOODS (DIMENSIONLESS)

changes in MPCONA diminishes due to the reluctance of producers to large changes in the production capacity. When the value of AVICOG is 2, MPCONA is assumed to be 0.6.

The availability indicator for consumption goods AVICOG, Equation 96, is a weighted average of the availability of consumption goods (in the market) AVCOG and the ratio of output of consumption goods OUTCON to the demand for consumption goods DCONG. The weighting factor is the market effect coefficient

AVICOG.K=MEC\*AVCOG.K+(1-MEC)\*(OUTCON.K/DCONG.K) 96, A  
MEC=.5 96.1, C  
AVICOG - AVAILABILITY INDICATOR FOR CONSUMPTION  
GOODS (DIMENSIONLESS)  
MEC - MARKET EFFECT COEFFICIENT (DIMENSIONLESS)  
AVCOG - AVAILABILITY OF CONSUMPTION GOODS  
(DIMENSIONLESS)  
OUTCON - OUTPUT OF CONSUMPTION GOODS SECTOR (1E6  
RIALS/YEAR)  
DCONG - DEMAND FOR CONSUMPTION GOODS (1E6 RIALS/  
YEAR)

MEC. MEC is a policy parameter. The greater the value of MEC, the more market mechanisms rather than import substitution possibilities influence the expansion of the sector, and vice versa. For the simulations in this thesis, the value of MEC is assumed to be .5. Different imports substitution policies can be examined by assigning different values to MEC.

The availability of consumption goods (in the market) AVCOG, Equation 97, is equal to total consumption goods TCONG divided by demand for consumption goods DCONG.

$$\text{AVCOG.K} = \text{TCONG.K} / \text{DCONG.K} \quad 97, \text{ A}$$

AVCOG - AVAILABILITY OF CONSUMPTION GOODS  
(DIMENSIONLESS)  
TCONG - TOTAL CONSUMPTION GOODS (1E6 RIALS/YEAR)  
DCONG - DEMAND FOR CONSUMPTION GOODS (1E6 RIALS/  
YEAR)

Demand for consumption goods DCONG, Equation 98, is the summation of domestic demand for consumption goods DDCONG, demand for construction DDCONS, and exported consumption goods ECONG, approximating foreign demand for the sector's output.

$$\text{DCONG.K} = \text{DDCONG.K} + \text{ECONG.K} + \text{DDCONS.K} \quad 98, \text{ A}$$

DCONG - DEMAND FOR CONSUMPTION GOODS (1E6 RIALS/  
YEAR)  
DDCONG - DOMESTIC DEMAND FOR CONSUMPTION GOODS (1E6  
RIALS/YEAR)  
ECONG - EXPORTED CONSUMPTION GOODS (1E6 RIALS/YEAR)  
DDCONS - DOMESTIC DEMAND FOR CONSTRUCTION (1E6  
RIALS/YEAR)

Total consumption goods TCONG, Equation 99, is equal to the output of consumption goods OUTCON plus imported consumption goods ICONG minus exported consumption goods ECONG.

$$\text{TCONG.K} = \text{OUTCON.K} + \text{ICONG.K} - \text{ECONG.K} \quad 99, \text{ A}$$

TCONG - TOTAL CONSUMPTION GOODS (1E6 RIALS/YEAR)  
OUTCON - OUTPUT OF CONSUMPTION GOODS SECTOR (1E6  
RIALS/YEAR)  
ICONG - IMPORTED CONSUMPTION GOODS (1E6 RIALS/YEAR)  
ECONG - EXPORTED CONSUMPTION GOODS (1E6 RIALS/YEAR)

#### A.5 CAPITAL GOODS SECTOR

Equations 101 through 122 which follow represent the formulation of the capital goods sector in the model. These equations and their descriptions are very similar to those for the consumption goods sector. The description of the equations of the capital goods is omitted in order to prevent the repetition of what was explained in the previous section. Only the points of difference between these equations and the equations of the consumption goods sector will be explained.

Intermediate goods value added ratio in the capital goods sector IVARCA, Equation 101.1, is set constant at 2 because manufacturing is the only production activity in the sector. The use of intermediate goods per value added in the manufacturing of capital goods can be approximately assumed constant. Based on data from Iranian Industrial Statistics 1972, Table A.7 shows the ratio of intermediate goods to value added in the capital goods sector in different years from 1962 to 1971. The average value of the ratio during the period shown in Table A.7 is 2.038, approximately the same as the value chosen for IVARCA in the model.

Table A.7

The Ratio of Intermediate Goods to Value Added  
in the Capital Goods Sector IVARCA of Iran  
During 1962 to 1971.

Year	1962	1963	1964	1965	1966	1967	1968	1969	1970	1971	Average
IVARCA	1.65	1.56	1.76	2.2	1.78	2.02	2.65	2.2	1.98	2.54	2.038

Utilization factor in the capital goods sector from intermediate goods availability UFCAIA, Equation 103, is a function of availability of intermediate goods AVIG. Figure A.18 depicts their functional relationship. The shape of the curve in Figure A.18 is similar to the shape of the relationship between utilization factor in the consumption goods sector from intermediate goods availability UFCOIA and AVIG, shown in Figure A.12. Like the extreme values of UFCOIA in Figure A.12, for AVIG equals zero and one, the extreme values of UFCAIA are also zero and one, respectively. However, as the values of AVIG decrease below one, the values assumed for UFCAIA decrease more steeply than those for UFCOIA do. The reason is that, unlike the consumption goods sector, all the production activities in the capital goods sector are manufacturing - the consumption goods sector includes manufacturing of consumption goods, construction and services. The production activities in manufacturing use more intermediate goods per value added than in services. The dependence of manufacturing on intermediate goods is more than the dependence of services. Therefore, an intermediate goods shortage would lower production activities in the capital goods sector more than it would lower production activities in the consumption goods sector. Hence, the values of UFCAIA in Figure A.18 drop more steeply than the corresponding values of UFCOIA do in Figure A.12, as AVIG decreases below 1.

Experience in the capital goods sector EXCAP, Equation 109, is a smooth function of value added in capital goods sector, similar to the formulation of experience in the consumption goods sector EXCON in Equation 86. However, the time to average experience in the capital goods sector TAECA

is assumed to be 10 years, longer than the 5 years assumed in the consumption goods sector for TAECO in Equation 86.1. TAECA is assumed longer than TAECO because the production of capital goods requires more skill and a longer training period than the production of consumption goods and services. Also, in Equation 109.3, experience in capital goods initial EXCAPN is set at 640 million rials per year, 20% lower than the value added in the sector in 1959, which was 800 million rials at 1972 prices.

OUTCAP.K=VACAP.K\*(1+IVARCA) 101, A  
IVARCA=2 101.1, C  
OUTCAP - OUTPUT OF CAPITAL GOODS SECTOR(1E6 RIALS/  
YEAR)  
VACAP - VALUE ADDED IN CAPITAL GOODS SECTOR (1E6  
RIALS/YEAR)  
IVARCA - INTERMEDIATE GOODS VALUE ADDED RATIO IN  
CAPITAL GOODS SECTOR (DIMENSIONLESS)

VACAP.K=PCCAP.K\*UFCA.K 102, A  
VACAP - VALUE ADDED IN CAPITAL GOODS SECTOR (1E6  
RIALS/YEAR)  
PCCAP - PRODUCTION CAPACITY IN CAPITAL GOODS SECTOR  
(1E6 RIALS/YEAR)  
UFCA - UTILIZATION FACTOR IN CAPITAL GOODS SECTOR  
(DIMENSIONLESS)

UFCA.K=UFCAD.K\*UFCAIA.K 103, A  
UFCA - UTILIZATION FACTOR IN CAPITAL GOODS SECTOR  
(DIMENSIONLESS)  
UFCAD - UTILIZATION FACTOR IN CAPITAL GOODS SECTOR  
FROM DEMAND (DIMENSIONLESS)  
UFCAIA - UTILIZATION FACTOR IN CAPITAL GOODS SECTOR  
FROM INTERMEDIATE GOODS AVAILABILITY  
(DIMENSIONLESS)

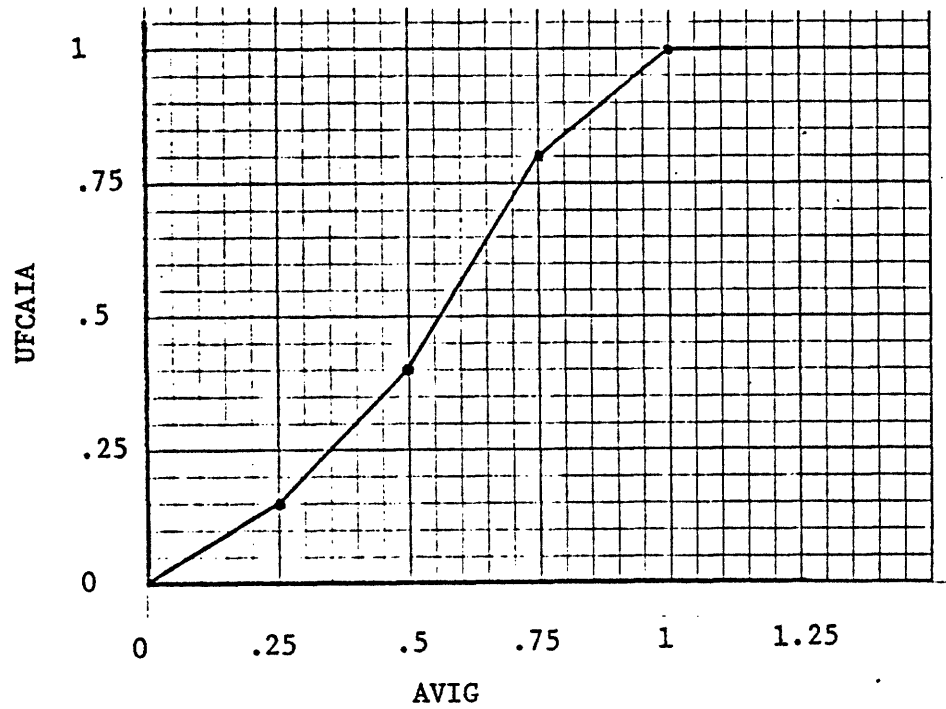

Figure A.18: Utilization Factor in the Capital Goods Sector from Intermediate Goods Availability Versus Availability of Intermediate Goods.

```
UFCAIA.K=TABHL(TUFCA,AVIG.K,0,1,.25)           104, A
TUFCA=0/.15/.4/.8/1                             104.1, T
UFCAIA - UTILIZATION FACTOR IN CAPITAL GOODS SECTOR
          FROM INTERMEDIATE GOODS AVAILABILITY
          (DIMENSIONLESS)
TUFCA - TABLE FOR UTILIZATION FACTOR IN CAPITAL
        GOODS SECTOR FROM INTERMEDIATE GOODS
        AVAILABILITY
AVIG - AVAILABILITY OF INTERMEDIATE GOODS
       (DIMENSIONLESS)
```

UFCAD.K=TABHL(TUFCAD,AAVCA.K,.75,2,.25) 105, A  
TUFCAD=1/1/.85/.7/.63/.6 105.1, T  
UFCAD - UTILIZATION FACTOR IN CAPITAL GOODS SECTOR  
FROM DEMAND (DIMENSIONLESS)  
TUFCAD - TABLE FOR UTILIZATION FACTOR IN CAPITAL  
GOODS SECTOR FROM DEMAND  
AAVCA - AVERAGE AVAILABILITY OF CAPITAL GOODS  
(DIMENSIONLESS)

AAVCA.K=SMOOTH(AVCAG.K,TAAVCA) 106, A  
TAAVCA=1 106.1, C  
AAVCA=1 106.2, N  
AAVCA - AVERAGE AVAILABILITY OF CAPITAL GOODS  
(DIMENSIONLESS)  
AVCAG - AVAILABILITY OF CAPITAL GOODS  
(DIMENSIONLESS)  
TAAVCA - TIME TO AVERAGE AVAILABILITY OF CAPITAL  
GOODS (YEARS)

PCCAP.K=PPCAP.K\*PRCAP.K 107, A  
PCCAP - PRODUCTION CAPACITY IN CAPITAL GOODS SECTOR  
(1E6 RIALS/YEAR)  
PPCAP - POTENTIAL PRODUCTION CAPACITY IN CAPITAL  
GOODS SECTOR (1E6 RIALS/YEAR)  
PRCAP - PRODUCTIVITY IN CAPITAL GOODS SECTOR  
(DIMENSIONLESS)

PRCAP.K=TABHL(TPRCA,EXICAP.K,0,1,.2) 108, A  
TPRCA=0/.45/.70/.85/.95/1 108.1, T  
PRCAP - PRODUCTIVITY IN CAPITAL GOODS SECTOR  
(DIMENSIONLESS)  
TPRCA - TABLE FOR PRODUCTIVITY IN CAPITAL GOODS  
SECTOR  
EXICAP - EXPERIENCE INDICATOR IN CAPITAL GOODS  
SECTOR (DIMENSIONLESS)

EXICAP.K=EXCAP.K/PPCAP.K 109, A  
EXICAP - EXPERIENCE INDICATOR IN CAPITAL GOODS  
SECTOR (DIMENSIONLESS)  
EXCAP - EXPERIENCE IN CAPITAL GOODS SECTOR (1E6  
RIALS/YEAR)  
PPCAP - POTENTIAL PRODUCTION CAPACITY IN CAPITAL  
GOODS SECTOR (1E6 RIALS/YEAR)

EXCAP.K=SMOOTH(VACAP.K,TAEXCA) 110, A  
TAEXCA=10 110.1, C  
EXCAP=EXCAPN 110.2, N  
EXCAPN=640 110.3, C

EXCAP - EXPERIENCE IN CAPITAL GOODS SECTOR (1E6  
RIALS/YEAR)  
VACAP - VALUE ADDED IN CAPITAL GOODS SECTOR (1E6  
RIALS/YEAR)  
TAEXCA - TIME TO AVERAGE EXPERIENCE IN CAPITAL GOODS  
SECTOR (YEARS)  
EXCAPN - EXPERIENCE IN CAPITAL GOODS INITIAL (1E6  
RIALS/YERA)

PPCAP.K=FPCAP.K\*PCIS.K 111, A  
PPCAP - POTENTIAL PRODUCTION CAPACITY IN CAPITAL  
GOODS SECTOR (1E6 RIALS/YEAR)  
FPCAP - FRACTION OF PRODUCTION CAPACITY IN CAPITAL  
GOODS SECTOR (DIMENSIONLESS)  
PCIS - PRODUCTION CAPACITY IN INDUSTRIAL SECTOR  
(1E6 RIALS/YEAR)

FPCAP.K=(ADPCAP.K)/(ADPCON.K+ADPI.K+ADPCAP.K+  
ADPE.K) 112, A  
FPCAP - FRACTION OF PRODUCTION CAPACITY IN CAPITAL  
GOODS SECTOR (DIMENSIONLESS)  
ADPCAP - AVERAGE DESIRED PRODUCTION CAPACITY IN  
CAPITAL GOODS SECTOR (1E6 RIALS/YEAR)  
ADPCON - AVERAGE DESIRED PRODUCTION CAPACITY IN  
CONSUMPTION GOODS SECTOR (1E6 RIALS/YEAR)  
ADPI - AVERAGE DESIRED PRODUCTION CAPACITY IN  
INTERMEDIATE GOODS SECTOR (1E6 RIALS/  
YEAR)  
ADPE - AVERAGE DESIRED PRODUCTION CAPACITY IN  
EDUCATION (1E6 RIALS/YEAR)

ADPCAP.K=SMOOTH(DPCAP.K,TADPCA) 113, A  
TADPCA=20 113.1, C  
ADPCAP=800 113.2, N

ADPCAP - AVERAGE DESIRED PRODUCTION CAPACITY IN  
CAPITAL GOODS SECTOR (1E6 RIALS/YEAR)  
DPCAP - DESIRED PRODUCTION CAPACITY IN CAPITAL  
GOODS SECTOR (1E6 RIALS /YEAR)  
TADPCA - TIME TO AVERAGE DESIRED PRODUCTION CAPACITY  
IN CAPITAL GOODS SECTOR (YEARS)



DPCAP.K=PPCAP.K\*MPCAPA.K\*MPCACU.K\*MPCAPR.K 114, A

- DPCAP - DESIRED PRODUCTION CAPACITY IN CAPITAL GOODS SECTOR (1E6 RIALS /YEAR)
- PPCAP - POTENTIAL PRODUCTION CAPACITY IN CAPITAL GOODS SECTOR (1E6 RIALS/YEAR)
- MPCAPA - MULTIPLIER FOR PRODUCTION CAPACITY IN CAPITAL GOODS SECTOR FROM AVAILABILITY (DIMENSIONLESS)
- MPCACU - MULTIPLIER FOR PRODUCTION CAPACITY IN CAPITAL GOODS SECTOR FROM CAPACITY UTILIZATION (DIMENSIONLESS)
- MPCAPR - MULTIPLIER FOR PRODUCTION CAPACITY IN CAPITAL GOODS SECTOR FROM PRODUCTIVITY (DIMENSIONLESS)

MPCACU.K=TABHL(TMPCAU,UFCA.K,0,1,.2) 115, A

TMPCAU=0/.4/.7/.85/.95/1 115.1, T

- MPCACU - MULTIPLIER FOR PRODUCTION CAPACITY IN CAPITAL GOODS SECTOR FROM CAPACITY UTILIZATION (DIMENSIONLESS)
- TMPCAU - TABLE FOR MULTIPLIER FOR PRODUCTION CAPACITY IN CAPITAL GOODS SCETOR FROM CAPACITY UTILIZATION
- UFCA - UTILIZATION FACTOR IN CAPITAL GOODS SECTOR (DIMENSIONLESS)

MPCAPR.K=TABHL(TMPCAPR,PRRCA.K,0,3,.5) 116, A

TMPCAPR=0/.6/1/1.3/1.55/1.7/1.8 116.1, T

- MPCAPR - MULTIPLIER FOR PRODUCTION CAPACITY IN CAPITAL GOODS SECTOR FROM PRODUCTIVITY (DIMENSIONLESS)
- TMPCAPR- TABLE FOR MULTIPLIER FOR PRODUCTION CAPACITY IN CAPITAL GOODS SECTOR FROM PRODUCTIVITY
- PRRCA - PRODUCTIVITY RATIO IN CAPITAL GOODS SECTOR (DIMENSIONLESS)

PRRCA.K=PRCAP.K/APRIS.K 117, A

- PRRCA - PRODUCTIVITY RATIO IN CAPITAL GOODS SECTOR (DIMENSIONLESS)
- PRCAP - PRODUCTIVITY IN CAPITAL GOODS SECTOR (DIMENSIONLESS)
- APRIS - AVERAGE PRODUCTIVITY IN INDUSTRIAL SECTOR (DIMENSIONLESS)

MPCAPA.K=TABHL(TMPCAP,AVICAG.K,0,2,.25) 118, A  
TMPCAP=2.6/2.4/2/1.45/1/.8/.7/.64/.6 118.1, T

MPCAPA - MULTIPLIER FOR PRODUCTION CAPACITY IN  
CAPITAL GOODS SECTOR FROM AVAILABILITY  
(DIMENSIONLESS)

TMPCAP - TABLE FOR MULTIPLIER FOR PRODUCTION  
CAPACITY IN CAPITAL GOODS SECTOR FROM  
AVAILABILITY

AVICAG - AVAILABILITY INDICATOR FOR CAPITAL GOODS  
(DIMENSIONLESS)

AVICAG.K=MECA\*AVCAG.K+(1-MECA)\*(OUTCAP.K/DCAPG.K) 119, A  
MECA=.5 119.1, C

AVICAG - AVAILABILITY INDICATOR FOR CAPITAL GOODS  
(DIMENSIONLESS)

MECA - MARKET EFFECT COEFFICIENT FOR CAPITAL GOODS  
(DIMENSIONLESS)

AVCAG - AVAILABILITY OF CAPITAL GOODS  
(DIMENSIONLESS)

OUTCAP - OUTPUT OF CAPITAL GOODS SECTOR(1E6 RIALS/  
YEAR)

DCAPG - DEMAND FOR CAPITAL GOODS (1E6 RIALS/YEAR)

AVCAG.K=TCAPG.K/DCAPG.K 120, A

AVCAG - AVAILABILITY OF CAPITAL GOODS  
(DIMENSIONLESS)

TCAPG - TOTAL CAPITAL GOODS (1E6 RIALS/YEAR)

DCAPG - DEMAND FOR CAPITAL GOODS (1E6 RIALS/YEAR)

DCAPG.K=DDCAPG.K+ECAPG.K 121, A

DCAPG - DEMAND FOR CAPITAL GOODS (1E6 RIALS/YEAR)

DDCAPG - DOMESTIC DEMAND FOR CAPITAL GOODS (1E6  
RIALS/YEAR)

ECAPG - EXPORTED CAPITAL GOODS (1E6 RIALS/YEAR)

TCAPG.K=OUTCAP.K+ICAPG.K-ECAPG.K 122, A

TCAPG - TOTAL CAPITAL GOODS (1E6 RIALS/YEAR)

OUTCAP - OUTPUT OF CAPITAL GOODS SECTOR(1E6 RIALS/  
YEAR)

ICAPG - IMPORTED CAPITAL GOODS (1E6 RIALS/YEAR)

ECAPG - EXPORTED CAPITAL GOODS (1E6 RIALS/YEAR)

#### A.6 INTERMEDIATE GOODS SECTOR

The following equations represent the formulation of the intermediate goods sector. This sector contains all production activities from mining raw materials to the production of unfinished goods to be delivered to the final goods producers. Some production units in the sector may use the output of other production units. For example, a steel mill, a production unit in the intermediate goods sector, uses iron ore and coal, the outputs of mining activities. The sector as a whole might use some imported intermediate goods - i.e., imported iron ore. The imported intermediate goods used in the sector and its value added determine the output of the intermediate goods sector.

However, for the sake of simplicity in the model, the intermediate goods sector does not use imported intermediate goods. The value added in the sector is assumed to be its output. The availability of intermediate goods, therefore, is also assumed not to affect the production ability of the sector. The independence of the production activities of this sector from intermediate goods availability is the major structural difference between the intermediate goods sector and the consumption and capital goods sectors. Beside this difference, the structures of the three sectors are quite similar.

Output of intermediate goods  $OUTI$ , Equation 124, is equal to the production capacity of intermediate goods sector  $PCI$  times utilization factor in intermediate goods sector from demand  $UFID$ .

OUTI.K=PCI.K\*UFID.K 124, A  
OUTI - OUTPUT OF INTERMEDIATE GOODS SECTOR (1E6  
RIALS/YEAR)  
PCI - PRODUCTION CAPACITY IN INTERMEDIATE GOODS  
SECTOR (1E6 RIALS/YEAR)  
UFID - UTILIZATION FACTOR IN INTERMEDIATE GOODS  
SECTOR FROM DEMAND (DIMENSIONLESS)

Equations 125 to 142 are similar to Equations 81 to 99 (except for Equation 94) explained in Section A.4 for the consumption goods sector. A full explanation of these equations is omitted to avoid repetition. However, there are two points to be mentioned about these equations. First, in Equation 130.1, time to average experience in intermediate goods sector TAEI is assumed to be 10 years, longer than the 5 years assumed in the consumption goods sector in Equation 85.1 for TAECO. TAEI is assumed to be longer than TAECO because the production of intermediate goods, mostly heavy industry, requires more skill and a longer training period than the production of services and consumption goods industry. Second, in Equation 130.3, the experience in intermediate goods sector initial EXIN is set at 4800 million rials per year, 20% lower than the value added in the sector in 1959, which was 6000 rials at 1972 prices.

UFID.K=TABHL(TUFID,AAVI.K,.75,2,.25) 125, A  
TUFID=1/1/.85/.7/.63/.6 125.1, T  
UFID - UTILIZATION FACTOR IN INTERMEDIATE GOODS  
SECTOR FROM DEMAND (DIMENSIONLESS)  
TUFID - TABLE FOR UTILIZATION FACTOR IN  
INTERMEDIATE GOODS SECTOR FROM DEMNAD  
AAVI - AVERAGE AVAILABILITY OF INTERMEDIATE GOODS  
(DIMENSIONLESS)

AAVI.K=SMOOTH(AVIG.K,TAAVI) 126, A  
TAAVI=1 126.1, C  
AAVI=1 126.2, N  
AAVI - AVERAGE AVAILABILITY OF INTERMEDIATE GOODS  
(DIMENSIONLESS)  
AVIG - AVAILABILITY OF INTERMEDIATE GOODS  
(DIMENSIONLESS)  
TAAVI - TIME TO AVERAGE AVAILABILITY OF  
INTERMEDIATE GOODS (YEARS)

PCI.K=PPI.K\*PRI.K 127, A  
PCI - PRODUCTION CAPACITY IN INTERMEDIATE GOODS  
SECTOR (1E6 RIALS/YEAR)  
PPI - POTENTIAL PRODUCTION CAPACITY IN  
INTERMEDIATE GOODS SECTOR (1E6 RIALS/  
YEAR)  
PRI - PRODUCTIVITY IN INTERMEDIATE GOODS SECTOR  
(DIMENSIONLESS)

PRI.K=TABHL(TPRI,EXII.K,0,1,.2) 128, A  
TPRI=0/.45/.70/.85/.95/1 128.1, T  
PRI - PRODUCTIVITY IN INTERMEDIATE GOODS SECTOR  
(DIMENSIONLESS)  
TPRI - TABLE FOR PRODUCTIVITY IN INTERMEDIATE  
GOODS SECTOR  
EXII - EXPERIENC EINDICATOR IN INTERMEDIATE GOODS  
SECTOR (DIMENSIONLESS)

EXII.K=EXI.K/PPI.K 129, A  
EXII - EXPERIENC EINDICATOR IN INTERMEDIATE GOODS  
SECTOR (DIMENSIONLESS)  
EXI - EXPERIENCE IN INTERMEDIATE GOODS SECTOR  
(1E6 RIALS/YEAR)  
PPI - POTENTIAL PRODUCTION CAPACITY IN  
INTERMEDIATE GOODS SECTOR (1E6 RIALS/  
YEAR)

EXI.K=SMOOTH(OUTI.K,TAEI) 130, A  
TAEI=10 130.1, C  
EXI=EXIN 130.2, N  
EXIN=4800 130.3, C  
EXI - EXPERIENCE IN INTERMEDIATE GOODS SECTOR  
(1E6 RIALS/YEAR)  
OUTI - OUTPUT OF INTERMEDIATE GOODS SECTOR (1E6  
RIALS/YEAR)  
TAEI - TIME TO AVERAGE EXPERIENCE IN INTERMEDIATE  
GOODS SECTOR (YEARS)  
EXIN - EXPERIENCE IN INTERMEDIATE GOODS SECTOR  
INITIAL (1E6 RIALS/RIALS)

$PPI.K = FPI.K * PCIS.K$  131, A

- PPI - POTENTIAL PRODUCTION CAPACITY IN INTERMEDIATE GOODS SECTOR (1E6 RIALS/YEAR)
- FPI - FRACTION OF PRODUCTION CAPACITY IN INTERMEDIATE GOODS SECTOR (DIMENSIONLESS)
- PCIS - PRODUCTION CAPACITY IN INDUSTRIAL SECTOR (1E6 RIALS/YEAR)

$FPI.K = (ADPI.K) / (ADPCON.K + ADPI.K + ADPCAP.K + ADPE.K)$  132, A

- FPI - FRACTION OF PRODUCTION CAPACITY IN INTERMEDIATE GOODS SECTOR (DIMENSIONLESS)
- ADPI - AVERAGE DESIRED PRODUCTION CAPACITY IN INTERMEDIATE GOODS SECTOR (1E6 RIALS/YEAR)
- ADPCON - AVERAGE DESIRED PRODUCTION CAPACITY IN CONSUMPTION GOODS SECTOR (1E6 RIALS/YEAR)
- ADPCAP - AVERAGE DESIRED PRODUCTION CAPACITY IN CAPITAL GOODS SECTOR (1E6 RIALS/YEAR)
- ADPE - AVERAGE DESIRED PRODUCTION CAPACITY IN EDUCATION (1E6 RIALS/YEAR)

$ADPI.K = \text{SMOOTH}(DPI.K, TADPI)$

TADPI=20

ADPI=6000

133, A

133.1, C

133.2, N

- ADPI - AVERAGE DESIRED PRODUCTION CAPACITY IN INTERMEDIATE GOODS SECTOR (1E6 RIALS/YEAR)
- DPI - DESIRED PRODUCTION CAPACITY IN INTERMEDIATE GOODS SECTOR (1E6 RIALS/YEAR)
- TADPI - TIME TO AVERAGE DESIRED PRODUCTION CAPACITY IN INTERMEDIATE GOODS SECTOR (YEARS)

$DPI.K = PPI.K * MPPIA.K * MPPIPR.K * MPICU.K$  134, A

- DPI - DESIRED PRODUCTION CAPACITY IN INTERMEDIATE GOODS SECTOR (1E6 RIALS/YEAR)
- PPI - POTENTIAL PRODUCTION CAPACITY IN INTERMEDIATE GOODS SECTOR (1E6 RIALS/YEAR)
- MPPIA - MULTIPLIER FOR PRODUCTION CAPACITY IN INTERMEDIATE GOODS SECTOR FROM AVAILABILITY (DIMENSIONLESS)
- MPPIPR - MULTIPLIER FOR PRODUCTION CAPACITY IN INTERMEDIATE GOODS SECTOR FROM PRODUCTIVITY (DIMENSIONLESS)
- MPICU - MULTIPLIER FOR PRODUCTION CAPACITY IN INTERMEDIATE GOODS SECTOR FROM CAPACITY UTILIZATION (DIMENSIONLESS)

MPICU.K=TABHL(TMPICU,UFID.K,0,1,.2) 135, A  
TMPICU=0/.4/.7/.85/.95/1 135.1, T

MPICU - MULTIPLIER FOR PRODUCTION CAPACITY IN  
INTERMEDIATE GOODS SECTOR FROM CAPACITY  
UTILIZATION (DIMENSIONLESS)

TMPICU - TABLE FOR MULTIPLIER FOR PRODUCTION  
CAPACITY IN INTERMEDIATE GOODS SECTOR  
FROM CAPACITY UTILIZATION

UFID - UTILIZATION FACTOR IN INTERMEDIATE GOODS  
SECTOR FROM DEMAND (DIMENSIONLESS)

MPIPR.K=TABHL(TMPIP,PRRI.K,0,3,.5) 136, A  
TMPIP=0/.6/1/1.3/1.55/1.7/1.8 136.1, T

MPIPR - MULTIPLIER FOR PRODUCTION CAPACITY IN  
INTERMEDIATE GOODS SECTOR FROM  
PRODUCTIVITY (DIMENSIONLESS)

TMPIP - TABLE FOR MULTIPLIER FOR PRODUCTION  
CAPACITY IN INTERMEDIATE GOODS SECTOR  
FROM PRODUCTIVITY

PRRI - PRODUCTIVITY RATIO IN INTERMEDIATE GOODS  
SECTOR (DIMENSIONLESS)

PRRI.K=PRI.K/APRIS.K 137, A

PRRI - PRODUCTIVITY RATIO IN INTERMEDIATE GOODS  
SECTOR (DIMENSIONLESS)

PRI - PRODUCTIVITY IN INTERMEDIATE GOODS SECTOR  
(DIMENSIONLESS)

APRIS - AVERAGE PRODUCTIVITY IN INDUSTRIAL SECTOR  
(DIMENSIONLESS)

MPIA.K=TABHL(TMPI,AVIIG.K,0,2,.25) 138, A  
TMPI=2.6/2.4/2/1.45/1/.8/.7/.64/.60 138.1, T

MPIA - MULTIPLIER FOR PRODUCTION CAPACITY IN  
INTERMEDIATE GOODS SECTOR FROM  
AVAILABILITY (DIMENSIONLESS)

TMPI - TABLE FOR MULTIPLIER FOR PRODUCTION  
CAPACITY IN INTERMEDIATE GOODS SECTOR  
FROM AVAILABILITY

AVIIG - AVAILABILITY INDICATOR OF INTERMEDIATE  
GOODS (DIMENSIONLESS)

$AVIIG.K = MEI * AVIG.K + (1 - MEI) * (OUTI.K / DIG.K)$  139, A  
MEI=.5 139.1, C

- AVIIG - AVAILABILITY INDICATOR OF INTERMEDIATE GOODS (DIMENSIONLESS)
- MEI - MARKET EFFECT FOR INTERMEDIATE GOODS (DIMENSIONLESS)
- AVIG - AVAILABILITY OF INTERMEDIATE GOODS (DIMENSIONLESS)
- OUTI - OUTPUT OF INTERMEDIATE GOODS SECTOR (1E6 RIALS/YEAR)
- DIG - DEMAND FOR INTERMEDIATE GOODS (1E6 RIALS/YEAR)

$AVIG.K = TIG.K / DIG.K$  140, A

- AVIG - AVAILABILITY OF INTERMEDIATE GOODS (DIMENSIONLESS)
- TIG - TOTAL INTERMEDIATE GOODS (1E6 RIALS/YEAR)
- DIG - DEMAND FOR INTERMEDIATE GOODS (1E6 RIALS/YEAR)

$DIG.K = DDIG.K + EIG.K$  141, A

- DIG - DEMAND FOR INTERMEDIATE GOODS (1E6 RIALS/YEAR)
- DDIG - DOMESTIC DEMAND FOR INTERMEDIATE GOODS (1E6 RIALS/YEAR)
- EIG - EXPORTED INTERMEDIATE GOODS (1E6 RIALS/YEAR)

$TIG.K = OUTI.K + IIG.K - EIG.K$  142, A

- TIG - TOTAL INTERMEDIATE GOODS (1E6 RIALS/YEAR)
- OUTI - OUTPUT OF INTERMEDIATE GOODS SECTOR (1E6 RIALS/YEAR)
- IIG - IMPORTED INTERMEDIATE GOODS (1E6 RIALS/YEAR)
- EIG - EXPORTED INTERMEDIATE GOODS (1E6 RIALS/YEAR)



Domestic demand for intermediate goods DDI, Equation 143, is the sum of demand for intermediate goods in consumption goods sector DICON and demand for intermediate goods in capital goods sector DICAP.

$$\text{DDIG.K} = \text{DICON.K} + \text{DICAP.K} \quad 143, \text{ A}$$

DDIG - DOMESTIC DEMAND FOR INTERMEDIATE GOODS (1E6 RIALS/YEAR)  
DICON - DEMAND FOR INTERMEDIATE GOODS IN CONSUMPTION GOODS SECTOR (1E6 RIALS/YEAR)  
DICAP - DEMAND FOR INTERMEDIATE GOODS IN CAPITAL GOODS SCETOR (1E6 RIALS/YEAR)

Demand for intermediate goods in consumption goods sector DICON is equal to production capacity in consumption goods sector PCCON times intermediate goods value added ratio in consumption goods sector IVARCO times utilization factor in consumption goods sector from demand UFCOD.

$$\text{DICON.K} = \text{PCCON.K} * \text{IVARCO.K} * \text{UFCOD.K} \quad 144, \text{ A}$$

DICON - DEMAND FOR INTERMEDIATE GOODS IN CONSUMPTION GOODS SECTOR (1E6 RIALS/YEAR)  
PCCON - PRODUCTION CAPACITY IN CONSUMPTION GOODS SECTOR (1E6 RIALS/YEAR)  
IVARCO - INTERMEDIATE-GOODS VALUE ADDED RATIO IN CONSUMPTION GOODS SECTOR (DIMENSIONLESS)  
UFCOD - UTILIZATION FACTOR IN CONSUMPTION GOODS SECTOR FROM DEMAND (DIMENSIONLESS)

PCCON, IVARCO, and UFCOD are determined in the consumption goods sector in Equations 83, 77, and 81, respectively.

Demand for intermediate goods in capital goods sector DICAP, Equation 145, is equal to production capacity in capital goods sector PCCAP times intermediate goods value added ratio in capital goods sector IVARVA times utilization factor in capital goods sector from demand UFCAD.

DICAP.K=PCCAP.K\*IVARCA\*UFCAD.K 145, A  
DICAP - DEMAND FOR INTERMEDIATE GOODS IN CAPITAL  
GOODS SCETOR (1E6 RIALS/YEAR)  
PCCAP - PRODUCTION CAPACITY IN CAPITAL GOODS SECTOR  
(1E6 RIALS/YEAR)  
IVARCA - INTERMEDIATE GOODS VALUE ADDED RATIO IN  
CAPITAL GOODS SECTOR (DIMENSIONLESS)  
UFCAD - UTILIZATION FACTOR IN CAPITAL GOODS SECTOR  
FROM DEMAND (DIMENSIONLESS)

PCCAP, IVARCA, and UFCAD are determined in the capital goods sector in Equations 107, 101.1, and 105, respectively.

#### A.7 ALLOCATION OF INCOME AND CAPITAL ACCUMULATION

Capital stock CAP, Equation 147, is increased by capital formation CAPF and decreased by capital depreciation CAPD. Capital stock intial CAPN is set at 499,300 million rials at 1972 prices, which was the value of capital stock of the country in 1959 as is shown in Table A.3.

CAP.K=CAP.J+DT\*(CAPF.JK-CAPD.JK) 147, L  
CAP=CAPN 147.1, N  
CAPN=499300 147.2, C  
CAP - CAPITAL STOCK (1E6 RIALS)  
CAPF - CAPITAL FORMATION (1E6 RIALS/YEAR)  
CAPD - CAPITAL DEPRECIATION (1E6 RIALS/YEAR)  
CAPN - CAPITAL STOCK INITIAL (1E6 RIALS)

Capital depreciation CAPD, Equation 148, is capital stock divided by life of capital LCAP. LCAP represents the average life of capital stock which consists of building and equipment. Usually average life of capital and buildings are assumed to be around 12 and 50 years, respectively. Therefore, LCAP, which is the average life of a composition of machinery and buildings, is assumed to be 25 years.

CAPD.KL=CAP.K/LCAP 148, R  
LCAP=25 148.1, C  
CAPD - CAPITAL DEPRECIATION (1E6 RIALS/YEAR)  
CAP - CAPITAL STOCK (1E6 RIALS)  
LCAP - LIFE OF CAPITAL (YEARS)

Capital formation CAPF, Equation 149, is a delayed value of the sum of total capital goods TCAPG and investment in construction ICONS. Delay for capital formation DCF is assumed to be 2 years.

CAPF.KL=DELAY1((TCAPG.K+ICONS.K),DCF) 149, R  
DCF=2 149.1, C  
CAPF - CAPITAL FORMATION (1E6 RIALS/YEAR)  
TCAPG - TOTAL CAPITAL GOODS (1E6 RIALS/YEAR)  
ICONS - INVESTMENT IN CONSTRUCTION (1E6 RIALS/YEAR)  
DCF - DELAY FOR CAPITAL FORMATION (YEARS)

Total capital goods is determined in the capital goods sector, in Equation 122, as a function of domestic output, imported, and exported capital goods. Imported and exported capital goods are formulated in the trade sector and are dependent on, among other factors, domestic demand for capital goods.

Domestic demand for capital goods DDCAPG, Equation 150, is the fraction of investment in capital equipment FICE multiplied by domestic demand for capital investment DDCAPI.

DDCAPG.K=FICE\*DDCAPI.K 150, A  
FICE=.317 150.1, C  
DDCAPG - DOMESTIC DEMAND FOR CAPITAL GOODS (1E6 RIALS/YEAR)  
FICE - FRACTION OF INVESTMENT IN CAPITAL EQUIPMENT (DIMENSIONLESS)  
DDCAPI - DOMESTIC DEMAND FOR CAPITAL INVESTMENT (1E6 RIALS/YEAR)

The fraction of investment in capital equipment FICE, Equation 150.1, represents the ratio of demand for capital equipment to total demand for

investment. Table A.10 shows the gross domestic fixed capital formation GDFCF and total capital equipment, composed of imports at C.I.F. and domestic output at factor cost, from 1962 through 1972. The ratio of total capital equipment to GDFCF is also shown in the third row of the table. The average ratio of capital equipment to the gross domestic fixed capital formation during 1962-1973 has been 0.317. Assuming that the ratio of demand for capital equipment to total demand for investment is the same as the ratio of actual investment in capital equipment to GDFCF, FICE is set at 0.317 in Equation 134.1.

TABLE A.10

GDFCF and Total Capital Equipment from 1962  
Through 1972 in Billion Rials at  
Current Prices

Year	1962	1963	1964	1965	1966	1967	1968	1969	1970	1971	1972	Aver
GDFCF	47.4	51.5	63.2	85.5	90.0	119.3	136.5	156.4	167.3	216.7	287.4	
Capital Equip.	15.4	14.4	21.4	26.3	30.5	37.5	44.2	49.1	93.6	65.3	88.5	
Ratio of Capital Equip. to GDFCF	.335	.284	.338	.308	.339	.314	.324	.314	.32	.301	.308	.317

Investment in construction ICONS represents expenditures on buildings, transportation infrastructure, and distribution and installation of capital equipment. ICONS, Equation 151, is equal to domestic demand for construction times the multiplier for investment in construction from availability MICONA.

ICONS.K=DDCONS.K\*MICONA.K 151, A  
ICONS - INVESTMENT IN CONSTRUCTION (1E6 RIALS/YEAR)  
DDCONS - DOMESTIC DEMAND FOR CONSTRUCTION (1E6  
RIALS/YEAR)  
MICONA - MULTIPLIER FOR INVESTMENT IN CONSTRUCTION  
FROM AVAILABILITY (DIMENSIONLESS)

The multiplier for investment in construction from availability MICONA, Equation 152, is a function of availability of consumption goods AVCOG. Figure A.19 shows the functional relationship. When AVCOG is less than one, indicating a shortage of output of the consumption goods sector, which includes the construction industry as well as the distribution and installation activities of the capital equipment, MICONA is also less than one and equal to AVCOG. When AVCOG becomes more than one, all the demand for investment in construction is assumed to be satisfied and MICONA is set at 1.

Domestic demand for construction DDCONS, Equation 153, is one minus the fraction of investment in capital equipment FICE times domestic demand for capital investment DDCAPI times multiplier for demand for construction from availability of capital goods MDCACG.

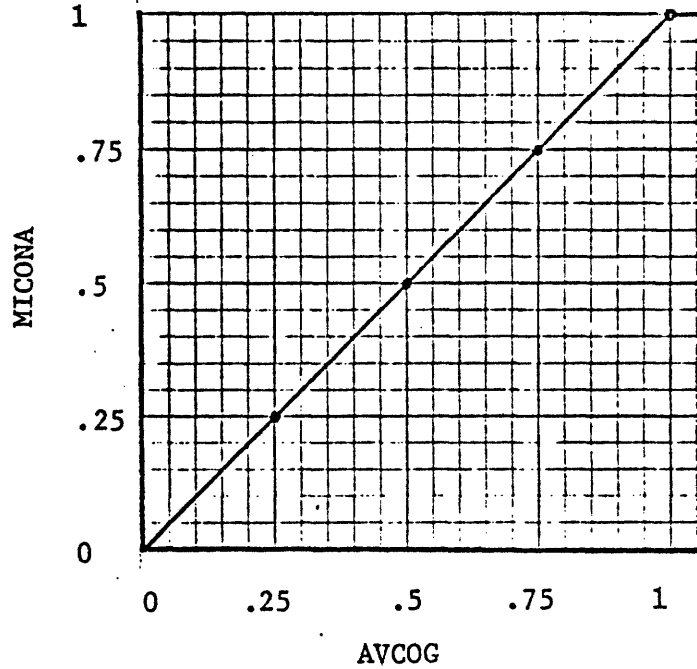

Figure A.19: Multiplier for Investment in Construction from Availability Versus Availability of Consumption Goods.

MICONA.K=TABHL(TMICON,AVCOG.K,0,1,.25) 152, A  
TMICON=0/.25/.5/.75/1 152.1, T

MICONA - MULTIPLIER FOR INVESTMENT IN CONSTRUCTION FROM AVAILABILITY (DIMENSIONLESS)

TMICON - TABLE FOR MULTIPLIER FOR INVESTMENT IN CONSTRUCTION FROM AVAILABILITY

AVCOG - AVAILABILITY OF CONSUMPTION GOODS (DIMENSIONLESS)

DDCONS.K=(1-FICE)\*DDCAPI.K\*MDCACG.K 153, A

DDCONS - DOMESTIC DEMAND FOR CONSTRUCTION (1E6 RIALS/YEAR)

FICE - FRACTION OF INVESTMENT IN CAPITAL EQUIPMENT (DIMENSIONLESS)

DDCAPI - DOMESTIC DEMAND FOR CAPITAL INVESTMENT (1E6 RIALS/YEAR)

MDCACG - MULTIPLIER FOR DEMAND FOR CONSTRUCTION FROM AVAILABILITY OF CAPITAL GOODS (DIMENSIONLESS)

Multiplier for demand for construction from availability of capital goods MDCACG, Equation 154, is a function of availability of capital goods

AVCAG. Figure A.20 shows the functional relationship between MDCACG and AVCAG. A part of demand for construction is demand for office buildings and

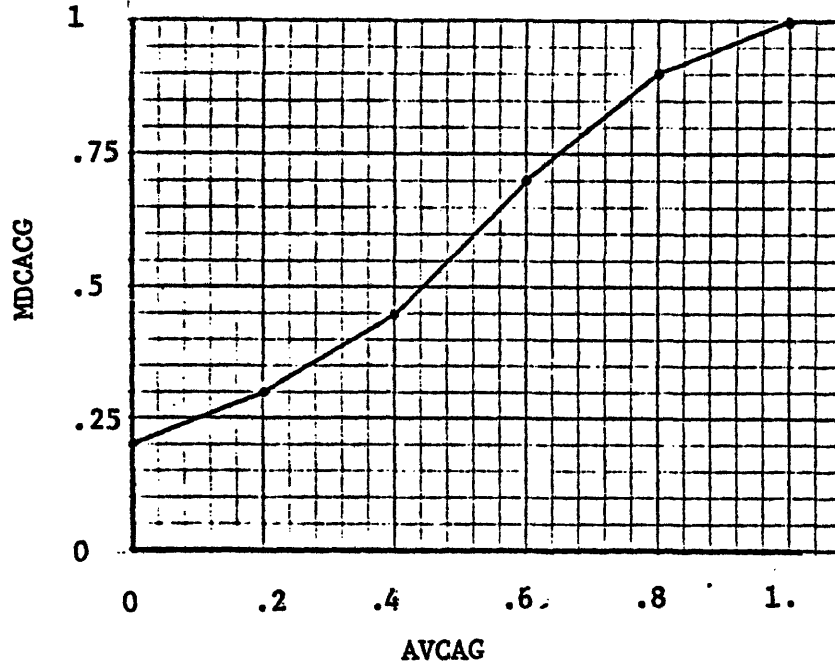

Figure A.20: Multiplier for Demand for Construction from Availability of Capital Equipment Versus Availability of Capital Equipment.

MDCACG.K=TABHL(TMDCACG,AVCAG.K,0,1,.2) 154, A  
TMDCACG=.2/.3/.45/.7/.9/1 154.1, T  
MDCACG - MULTIPLIER FOR DEMAND FOR CONSTRUCTION FROM  
AVAILABILITY OF CAPITAL GOODS  
(DIMENSIONLESS)  
TMDCACG- TABLE FOR MULTIPLIER FOR DEMAND FOR  
CONSTRUCTION FROM AVAILABILITY OF CAPITAL  
GOODS  
AVCAG - AVAILABILITY OF CAPITAL GOODS  
(DIMENSIONLESS)

plants which need capital equipment. When availability of capital goods AVCAG is less than one, indicating a shortage of capital equipment, demand for construction of commercial buildings decreases. As a result, total demand for construction drops. Therefore, as AVCAG decrease below one, so does MDCACG. However, when AVCAG becomes zero, uncommerical buildings can still be built and used. Therefore, when AVCAG equals zero, demand for construction does not drop to zero, and in Figure A.20, MDCACG is set equal to .2.

Domestic demand for capital investment DDCAPI, Equation 155, is equal to the desired fraction of income to be spent on investment DFI times available income per capita AIP times population POP.

$$\text{DDCAPI.K} = \text{DFI.K} * (\text{POP.K} / 1000000) * \text{AIPC.K} \quad 155, A$$

DDCAPI - DOMESTIC DEMAND FOR CAPITAL INVESTMENT (1E6 RIALS/YEAR)  
DFI - DESIRED FRACTION OF INCOME TO BE SPENT ON INVESTMENT (DIMENSIONLESS)  
POP - POPULATION (PERSONS)  
AIPC - AVAILABLE INCOME PER CAPITA (RIALS/PERSON/YEAR)

Similar to the formulation of DDCAPI, domestic demand for food DDF, Equation 156, is based on the desired fraction of income to be spent on food DFF, available income per capita AIPC, and population POP.

$$\text{DDF.K} = \text{DFF.K} * (\text{POP.K} / 1000000) * \text{AIPC.K} \quad 156, A$$

DDF - DOMESTIC DEMAND FOR FOOD (1E6 RIALS/YEAR)  
DFF - DESIRED FRACTION OF INCOME TO BE SPENT ON FOOD (DIMENSIONLESS)  
POP - POPULATION (PERSONS)  
AIPC - AVAILABLE INCOME PER CAPITA (RIALS/PERSON/YEAR)



The domestic demand for consumption goods DDCONG is demand for consumption goods and services excluding expenditure on education. DDCONG, Equation 157, is equal to the desired fraction to be spent on consumption goods and services DFC times available income per capita AVIPC times population POP minus production capacity in education PCE. PCE represents the educational expenditures.

$$\text{DDCONG.K} = \text{DFC.K} * (\text{POP.K} / 1000000) * \text{AIPC.K} - \text{PCE.K} \quad 157, \text{ A}$$

DDCONG - DOMESTIC DEMAND FOR CONSUMPTION GOODS (1E6 RIALS/YEAR)

DFC - DESIRED FRACTION OF INCOME TO BE SPENT ON CONSUMPTION (DIMENSIONLESS)

POP - POPULATION (PERSONS)

AIPC - AVAILABLE INCOME PER CAPITA (RIALS/PERSON/YEAR)

PCE - PRODUCTION CAPACITY IN EDUCATION SECTOR (1E6 RIALS/YEAR)

The desired fraction of income to be spent on food DFF, Equation 158, is a function of available income per capita AVIPC. Figure A.21 illustrates the functional relationship between DFF and AVIPC. At a subsistence level, when income per capita is very low, most of the income is spent on food for survival. In the extreme, when available income per capita AIPC is zero, DFF is set at one, as shown in Figure A.21. As AIPC increases, DFF rises. Figure A.21 shows some data points from Iran between 1959 and 1974. Each data point shows the fraction of GNP spent on food versus GNP per capita, which are good approximations for DFF and AIPC, respectively. The rate of drop in DFF diminishes as AIPC rises. When AIPC becomes 100,000 rials per year per person in 1972 prices, DFF is assumed to be 0.105.

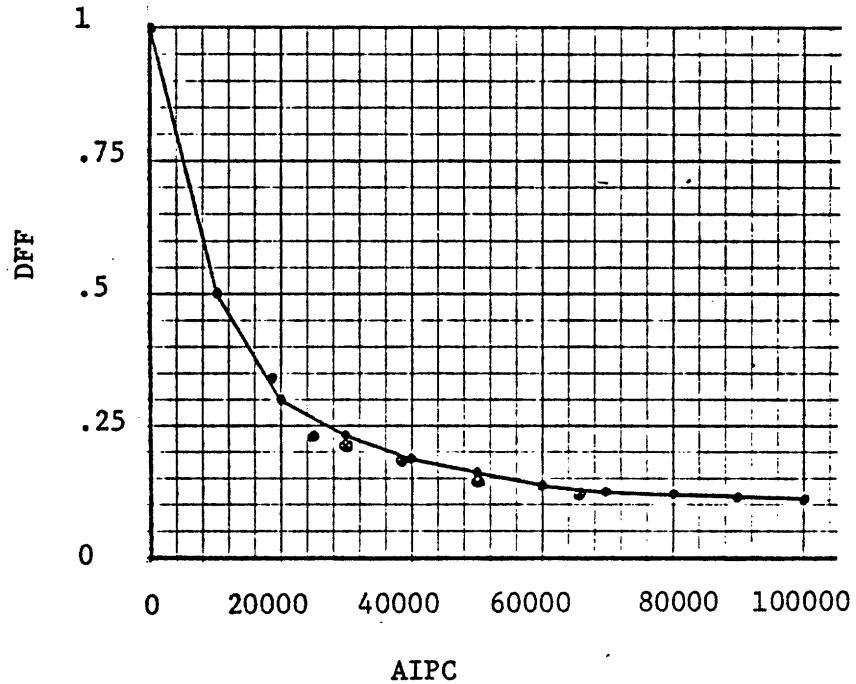

Figure A.21: Desired Fraction of Income to be Spent on Food Versus Available Income per Capita.

Sources of Data: Derived by the author based on data in SRU March 1976 and BMAR different issues.

```

DFF.K=TABHL(TDFF,AIPC.K,0,100000,10000)          158, A
TDFF=1/.5/.3/.23/.19/.16/.14/.125/.116/.11/.105  158.1, T
DFF      - DESIRED FRACTION OF INCOME TO BE SPENT ON
           FOOD (DIMENSIONLESS)
TDFF     - TABLE FOR DESIRED FRACTION OF INCOME TO BE
           SPENT ON FOOD
AIPC     - AVAILABLE INCOME PER CAPITA (RIALS/PERSON/
           YEAR)
```

The desired fraction of income to be spent on investment DFI, Equation 159, is a function of available income per capita AIPC. Figure A.22 depicts the functional relationship between DFI and AIPC. When AIPC is zero, DFI is set at zero. As AIPC increases, so does DFI, with a diminishing rate. When AIPC becomes 100,000 rials per year per person, DFI levels off at 0.26.

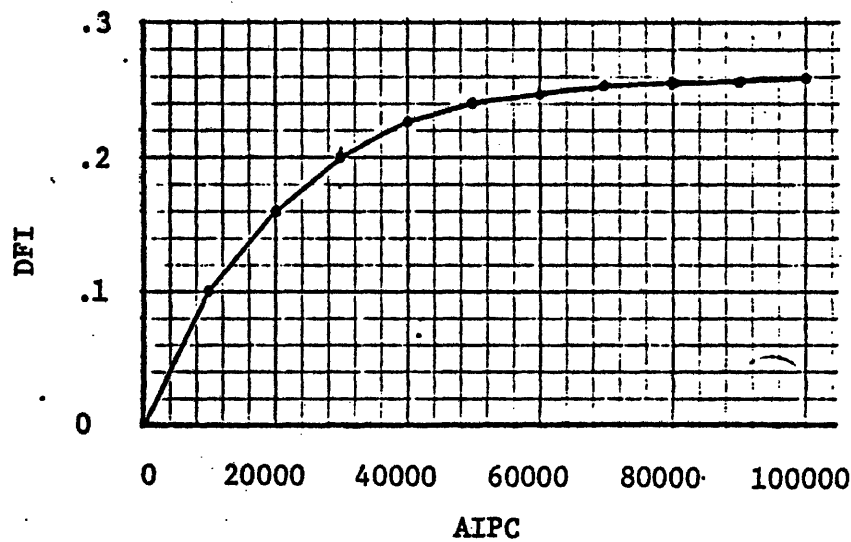

Figure A.22: Desired Fraction of Income to be Spent on Investment Versus Available Income per Capita.

```
DFI.K=TABHL(TDFI,AIPC.K,0,100000,10000) 159, A
TDFI=0/.10/.16/.20/.225/.24/.248/.253/.257/.259/.26 159.1, T
DFI - DESIRED FRACTION OF INCOME TO BE SPENT ON
      INVESTMENT (DIMENSIONLESS)
TDFI - TABLE FOR DESIRED FRACTION OF INCOME TO BE
      SPENT ON INVESTMENT
AIPC - AVAILABLE INCOME PER CAPITA (RIALS/PERSON/
      YEAR)
```

The desired fraction of income to be spent on consumption DFC, Equation 160, is one minus the desired fraction to be spent on food DFF and the desired fraction to be spent on investment DFI. Therefore, the sum of DFF, DFD, and DFC will always be one - i.e., total desired expenditure will be equal to available income.

$$DFC.K = 1 - DFF.K - DFI.K \quad 160, A$$

DFC - DESIRED FRACTION OF INCOME TO BE SPENT ON CONSUMPTION (DIMENSIONLESS)  
DFF - DESIRED FRACTION OF INCOME TO BE SPENT ON FOOD (DIMENSIONLESS)  
DFI - DESIRED FRACTION OF INCOME TO BE SPENT ON INVESTMENT (DIMENSIONLESS)

Available income per capita AIPC, Equation 161, is equal to foreign exchange reserves FE divided by time to spent accumulated income TSAIN plus GNP divided by population POP. TSAIN, which is time to spent accumulated income in the form of foreign exchange reserves, is assumed to be one year.

$$AIPC.K = ((FE.K / TSAIN) + GNP.K) * 1000000 / POP.K \quad 161, A$$

TSAIN=1 161.1, C

AIPC - AVAILABLE INCOME PER CAPITA (RIALS/PERSON/YEAR)  
FE - FOREIGN EXCHANGE RESERVES (1E6 RIALS)  
TSAIN - TIME TO SPENT ACCUMULATED INCOME (YEARS)  
GNP - GROSS NATIONAL PRODUCT (1E6 RIALS/YEAR)  
POP - POPULATION (PERSONS)

Gross National Product, GNP, Equation 162, is equal to non-oil output NOO plus oil revenues OILREV.

$$\text{GNP.K} = \text{NOO.K} + \text{OILREV.K} \quad 162, \text{ A}$$

GNP - GROSS NATIONAL PRODUCT (1E6 RIALS/YEAR)  
NOO - NON-OIL OUTPUT (1E6 RIALS/YEAR)  
OILREV - OIL REVENUES (1E6 RIALS/YEAR)

The non-oil output NOO is the sum of value added in the consumption goods sector VACON, the output of the intermediate goods sector OUTI, value added in the capital goods sector VACAP, food output FOUT, and the production capacity in the education sector PCE. PCE is assumed to be equal to value added in the education sector.

$$\text{NOO.K} = \text{VACON.K} + \text{OUTI.K} + \text{VACAP.K} + \text{FOUT.K} + \text{PCE.K} \quad 163, \text{ A}$$

NOO - NON-OIL OUTPUT (1E6 RIALS/YEAR)  
VACON - VALUE ADDED IN CONSUMPTION GOODS SECTOR (1E6 RIALS/YEAR)  
OUTI - OUTPUT OF INTERMEDIATE GOODS SECTOR (1E6 RIALS/YEAR)  
VACAP - VALUE ADDED IN CAPITAL GOODS SECTOR (1E6 RIALS/YEAR)  
FOUT - FOOD OUTPUT (1E6 RIALS/YEAR)  
PCE - PRODUCTION CAPACITY IN EDUCATION SECTOR (1E6 RIALS/YEAR)

Gross National Product per capita GNPPC, Equation 164, is Gross National Product GNP divided by population POP.

$$\text{GNPPC.K} = (\text{GNP.K} * 1000000) / \text{POP.K} \quad 164, \text{ A}$$

GNPPC - GROSS NATIONAL PRODUCT PER CAPITA (RIALS/YEAR/PERSON)  
GNP - GROSS NATIONAL PRODUCT (1E6 RIALS/YEAR)  
POP - POPULATION (PERSONS)

A.8 FOREIGN TRADE

A.8.1 Imports and Exports of Food

Foreign exchange reserves FE, Equation 166, are increased by total exports TE and decreased by total imports TI. The foreign exchange reserves initial FEN is set at 10,000 millions 1972 rials, which is equal to the deflated value of foreign exchange reserves in Iran in 1959. The deflator of total imports from SRU March 1976 was used to deflate the value of foreign exchange reserves in 1959 as given in BMAR 1349.

$FE.K = FE.J + DT * (TE.JK - TI.JK)$	166, L
$FE = FEN$	166.1, N
$FEN = 10000$	166.2, C
FE - FOREIGN EXCHANGE RESERVES (1E6 RIALS)	
TE - TOTAL EXPORTS (1E6 RIALS/YEAR)	
TI - TOTAL IMPORTS (1E6 RIALS/YEAR)	
FEN - FOREIGN EXCHANGE RESERVES INITIAL (1E6 RIALS)	

Total imports TI, Equation 167, is the sum of imported food IF, imported intermediate goods IIG, imported consumption goods ICONG, and imported capital goods ICAPG.

$TI.KL = IF.K + IIG.K + ICONG.K + ICAPG.K$	167, R
TI - TOTAL IMPORTS (1E6 RIALS/YEAR)	
IF - IMPORTED FOOD (1E6 RIALS/YEAR)	
IIG - IMPORTED INTERMEDIATE GOODS (1E6 RIALS/YEAR)	
ICONG - IMPORTED CONSUMPTION GOODS (1E6 RIALS/YEAR)	
ICAPG - IMPORTED CAPITAL GOODS (1E6 RIALS/YEAR)	

In Equations 168 and 169, two supplementary variables are determined to be plotted as the model's output. In Equation 168, imported food and capital goods IFCA is the sum of imported food and imported capital goods. In

Equation 169, imported food, capital goods, and intermediate goods IFCAI is determined as the sum of imported food, imported intermediate goods and imported capital goods.

$$\begin{aligned} \text{IFCA.K} &= \text{IF.K} + \text{ICAPG.K} && 168, \text{ S} \\ \text{IFCA} & - \text{IMPORTED FOOD AND CAPITAL GOODS (1E6 RIALS/} \\ & \text{YEAR)} \\ \text{IF} & - \text{IMPORTED FOOD (1E6 RIALS/YEAR)} \\ \text{ICAPG} & - \text{IMPORTED CAPITAL GOODS (1E6 RIALS/YEAR)} \end{aligned}$$

$$\begin{aligned} \text{IFCAI.K} &= \text{IF.K} + \text{ICAPG.K} + \text{IIG.K} && 169, \text{ S} \\ \text{IFCAI} & - \text{IMPORTED FOOD AND CAPITAL GOODS AND} \\ & \text{INTERMEDIATE GOODS (1E6 RIALS/YEAR)} \\ \text{IF} & - \text{IMPORTED FOOD (1E6 RIALS/YEAR)} \\ \text{ICAPG} & - \text{IMPORTED CAPITAL GOODS (1E6 RIALS/YEAR)} \\ \text{IIG} & - \text{IMPORTED INTERMEDIATE GOODS (1E6 RIALS/} \\ & \text{YEAR)} \end{aligned}$$

Total exports TE, Equation 170, is the sum of oil revenues OILREV and non-oil exports NOE.

$$\begin{aligned} \text{TE.KL} &= \text{OILREV.K} + \text{NOE.K} && 170, \text{ R} \\ \text{TE} & - \text{TOTAL EXPORTS (1E6 RIALS/YEAR)} \\ \text{OILREV} & - \text{OIL REVENUES (1E6 RIALS/YEAR)} \\ \text{NOE} & - \text{NON-OIL EXPORTS (1E6 RIALS/YEAR)} \end{aligned}$$

Non-oil exports NOE, Equation 171, is the sum of exported food EF, exported intermediate goods EXI, exported consumption goods ECONG, and exported capital goods ECAPG.

$$\begin{aligned} \text{NOE.K} &= \text{EF.K} + \text{EIG.K} + \text{ECONG.K} + \text{ECAPG.K} && 171, \text{ A} \\ \text{NOE} & - \text{NON-OIL EXPORTS (1E6 RIALS/YEAR)} \\ \text{EF} & - \text{EXPORTED FOOD (1E6 RIALS/YEAR)} \\ \text{EIG} & - \text{EXPORTED INTERMEDIATE GOODS (1E6 RIALS/} \\ & \text{YEAR)} \\ \text{ECONG} & - \text{EXPORTED CONSUMPTION GOODS (1E6 RIALS/YEAR)} \\ \text{ECAPG} & - \text{EXPORTED CAPITAL GOODS (1E6 RIALS/YEAR)} \end{aligned}$$

Imported food IF, Equation 172, is equal to desired imported food DIF times the multiplier for import of food from foreign exchange availability MIFFEA.

$$IF.K = DIF.K * MIFFEA.K \quad 172, A$$

IF - IMPORTED FOOD (1E6 RIALS/YEAR)  
DIF - DESIRED IMPORT OF FOOD (1E6 RIALS/YEAR)  
MIFFEA - MULTIPLIER FOR IMPORT OF FOOD FROM FOREIGN EXCHANGE AVAILABILITY (DIMENSIONLESS)

The multiplier for import of food from foreign exchange availability MIFFEA, Equation 173, is a function of foreign exchange availability indicator FAVI. Figure A.23 shows the functional relationship between MIFFEA and FAVI. When FAVI is zero, in the long run, the country can not import any food. Therefore, for a zero value of FAVI, MIFFEA is set at zero.

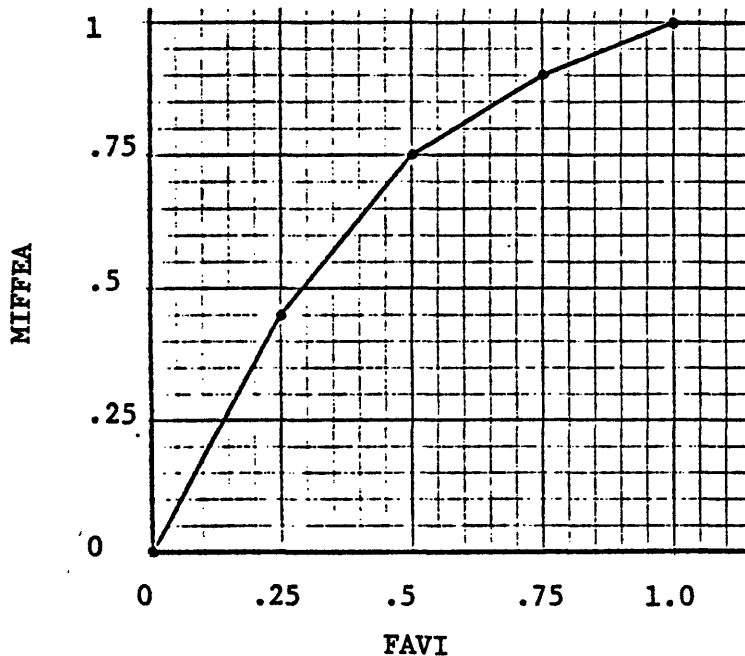

Figure A.23: Multiplier for Imported Food from Foreign Exchange Availability Versus Availability Indicator of Foreign Exchange.



$MIFFEA.K = TABHL(TMIFFE, FAVI.K, 0, 1, .25)$  173, A  
 $TMIFFE = 0/.45/.7/.9/1$  173.1, T  
 MIFFEA - MULTIPLIER FOR IMPORT OF FOOD FROM FOREIGN  
 EXCHANGE AVAILABILITY (DIMENSIONLESS)  
 TMIFFE - TABLE FOR MULTIPLIER FOR IMPORT OF FOOD  
 FROM FOREIGN EXCHANGE AVAILABILITY  
 FAVI - FOREIGN EXCHANGE AVAILABILITY INDICATOR  
 (DIMENSIONLESS)

As FAVI increases, so does MIFFEA, with a diminishing rate. Finally, when FAVI exceeds one, MIFFEA levels off at one.

Foreign exchange availability indicator FAVI, Equation 174, is equal to foreign exchange reserves FE divided by the product of normal foreign exchange coverage time NFEC and average total desired imports ATDI. NFEC is assumed to be 0.25 year or 3 months.

$FAVI.K = FE.K / (NFEC * ATDI.K)$  174, A  
 FAVI - FOREIGN EXCHANGE AVAILABILITY INDICATOR  
 (DIMENSIONLESS)  
 FE - FOREIGN EXCHANGE RESERVES (1E6 RIALS)  
 NFEC - NORMAL FOREIGN EXCHANGE COVERAGE TIME  
 (YEARS)  
 ATDI - AVERAGE TOTAL DESIRED IMPORTS (1E6 RIALS/  
 YEAR)

Average total desired imports ATDI, Equation 175, is a smoothed value of total desired imports TDI. Time to average total desired imports TATDI is assumed to be one year. The initial value of average total desired imports is set at 62,700 million rials at 1972 prices, which is equal to the total imports of the country in 1959 at constant 1972 prices.

$ATDI.K = SMOOTH(TDI.K, TATDI)$  175, A  
 $TATDI = 1$  175.1, C  
 $ATDI = 62700$  175.2, N  
 $NFEC = .25$  175.3, C  
 ATDI - AVERAGE TOTAL DESIRED IMPORTS (1E6 RIALS/  
 YEAR)  
 TDI - TOTAL DESIRED IMPORTS (1E6 RIALS/YEAR)  
 TATDI - TIME TO AVERAGE TOTAL DESIRED IMPORTS  
 (YEARS)  
 NFEC - NORMAL FOREIGN EXCHANGE COVERAGE TIME  
 (YEARS)

Total desired imports TDI, Equation 176, is the sum of desired import of food DIF, desired import of consumption goods DICO, desired import of intermediate goods, and desired import of capital goods DICA.

$$\begin{aligned} \text{TDI.K} &= \text{DIF.K} + \text{DICO.K} + \text{DII.K} + \text{DICA.K} && 176, \text{ A} \\ \text{TDI} & - \text{TOTAL DESIRED IMPORTS (1E6 RIALS/YEAR)} \\ \text{DIF} & - \text{DESIRED IMPORT OF FOOD (1E6 RIALS/YEAR)} \\ \text{DICO} & - \text{DESIRED IMPORT OF CONSUMPTION GOODS (1E6} \\ & \quad \text{RIALS/YEAR)} \\ \text{DII} & - \text{DESIRED IMPORT OF INTERMEDIATE GOODS (1E6} \\ & \quad \text{RIALS/YEAR)} \\ \text{DICA} & - \text{DESIRED IMPORT OF CAPITAL GOODS (1E6 RIALS/} \\ & \quad \text{YEAR)} \end{aligned}$$

The desired import of food DIF, Equation 177, is equal to the fraction for import of food FIF times food output FOUT.

$$\begin{aligned} \text{DIF.K} &= \text{FIF.K} * \text{FOUT.K} && 177, \text{ A} \\ \text{DIF} & - \text{DESIRED IMPORT OF FOOD (1E6 RIALS/YEAR)} \\ \text{FIF} & - \text{FRACTION FOR IMPORT OF FOOD (DIMENSIONLESS)} \\ \text{FOUT} & - \text{FOOD OUTPUT (1E6 RIALS/YEAR)} \end{aligned}$$

The fraction for import of food FIF, Equation 178, is a function of the ratio of demand output discrepancy to output for food RDODOF and test of food importation TFI to examine different governmental policies. In Figure A.24, Curve A shows the functional relationship between FIF and RDODOF when TFI is one, and Curve B shows the relationship when TFI is zero.

Curve A, in Figure A.24, reflects an import policy which does not restrict food importation. When RDODOF is zero, indicating that domestic demand for food DDF is equal to food output FOUT, some trade of food is assumed to take place, and FIF is set at 0.04. When the value of RDODOF becomes negative, indicating that domestic food output is more than domestic demand, FIF decreases below 0.04. At RDODOF equals -0.25 and -0.5, FIF is

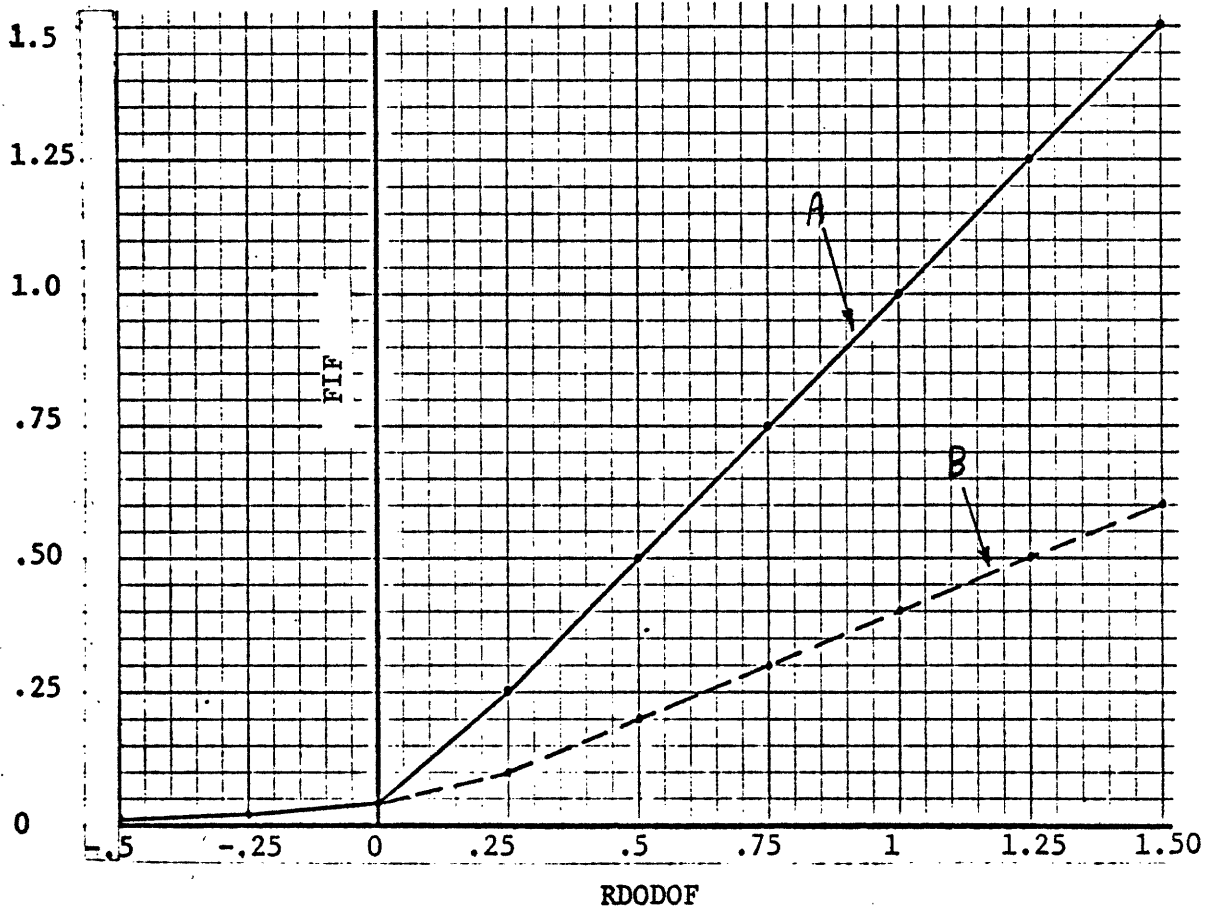

Figure A.24: The Fraction for Import of Food Versus the Ratio of Demand Output Discrepancy to Output for Food.

```

FIF.K=TFI.K*TABXT(TFIF,RDODOF.K,-.5,1.5,.25)+(1-      178, A
  TFI.K)*TABXT(TFIFT,RDODOF.K,-.5,1.5,.25)
TFIF=.01/.015/.04/.25/.5/.75/1.0/1.25/1.5          178.2, T
TFIFT=.01/.015/.04/.1/.2/.3/.4/.5/.6              178.3, T
  FIF      - FRACTION FOR IMPORT OF FOOD (DIMENSIONLESS)
  TFI      - TEST OF FOOD IMPORT POLICY (DIMENSIONLESS)
  TFIF     - TABLE FOR FRACTION FOR IMPORT OF FOOD
  RDODOF   - RATIO OF DEMAND OUTPUT DISCREPANCY TO
              OUTPUT FOR FOOD (DIMENSIONLESS)
  TFIFT    - TABLE FOR FRACTION FOR IMPORT OF FOOD FOR
              POLICY TEST
    
```

equal to 0.015 and 0.01, respectively. As RDODOF increases, so does FIF. For values of RDODOF above zero, FIF changes along a 45 degree line to indicate the lack of any restriction on food imports. On the 45 degree line where FIF is equal to the ratio of demand output discrepancy to output for food RDODOF, desired food import will be calculated as equal to the difference between domestic demand and domestic output of food. If the slope of the FIF curve decreases, it represents a rise in trade restriction on food imports. Different trade policies with regard to food importation can be examined in the model by changing the shape of FIF curve in Figure A.31.

Curve B, in Figure A.24, shows the relationship between FIF and RDODOF when the government imposes some restriction on food importation. On Curve B, when RDODOF is 1.5 - i.e., when demand output discrepancy for food is 1.5 food output - FIF is 0.6, indicating that the government allows only 60% of food output to be imported. The model adopts Curve B as the relationship between FIF and RDODOF when the value of TFI is set at zero.

The test of food importation TFI, Equation 179, is a CLIP function whose value is equal to one up to 1978 and equal to the test for food importation constant TFIC after 1978. TFIC is a constant whose value will be set either at one or zero. When TFIC is one, TFI will remain 1 after 1978 and Curve A will be used as the relationship between FIF and RDODOF throughout the simulation - i.e., no restriction will be imposed on food imports throughout the simulation. When TFIC is set at zero, after 1978, TFI will be zero and Curve B, in Figure A.31, will be used as the relationship between FIF and RDODOF thereafter - i.e., some restriction will be imposed on food importation after 1978.

TFI.K=CLIP(1,TFIC,1978,TIME.K) 179, A  
TFIC=1 179.1, C  
TFI - TEST OF FOOD IMPORT POLICY (DIMENSIONLESS)  
CLIP - CLIP FUNCTION  
TFIC - TEST OF FOOD IMPORT POLICY CONSTANT  
(DIMENSIONLESS)

The ratio of demand output discrepancy to output for food RDODOF, Equation 180, is equal to demand output discrepancy for food DODF divided by food output FOUT.

RDODOF.K=DODF.K/FOUT.K 180, A  
RDODOF - RATIO OF DEMAND OUTPUT DISCREPANCY TO  
OUTPUT FOR FOOD (DIMENSIONLESS)  
DODF - DEMAND OUTPUT DISCREPANCY FOR FOOD (1E6  
RIALS/YEAR)  
FOUT - FOOD OUTPUT (1E6 RIALS/YEAR)

Demand output discrepancy for food DODF, Equation 181, is equal to domestic demand for food DDF minus food output FOUT.

DODF.K=DDF.K-FOUT.K 181, A  
DODF - DEMAND OUTPUT DISCREPANCY FOR FOOD (1E6  
RIALS/YEAR)  
DDF - DOMESTIC DEMAND FOR FOOD (1E6 RIALS/YEAR)  
FOUT - FOOD OUTPUT (1E6 RIALS/YEAR)

Exported food EF, Equation 182, is equal to average export of food AEF times multiplier for export from desired export for food MEDEF.

EF.K=AEF.K\*MEDEF.K 182, A  
EF - EXPORTED FOOD (1E6 RIALS/YEAR)  
AEF - AVERAGE EXPORT OF FOOD (1E6 RIALS/YEAR)  
MEDEF - MULTIPLIER FOR EXPORT FROM DESIRED EXPORT  
FOR FOOD (DIMENSIONLESS)

Multiplier for export from desired export for food MEDEF, Equation 183, is a function of the ratio of desired export of food DEF to average

export of food AEF. Figure A.25 shows the functional relationship between MEDEF and  $(DEF/AEF)$ . When desired export of food DEF and, therefore,  $(DEF/AEF)$  are zero, no food is exported and MEDEF is zero. As  $(DEF/AEF)$  increases, so does MEDEF with a diminishing rate. When desired export of food DEF is equal to average export of food AEF and  $(DEF/AEF)$  becomes one, food exports will not change relative to average export of food. Therefore, when  $(DEF/AEF)$  is one, MEDEF is also set at one. As desired export of food DEF increases above average export of food AEF, MEDEF increases above one to raise food exports. However, expansion of exports is difficult and time-consuming. Exports expansion involves, among other tasks, competition in international markets, establishment of trademarks, and accumulation of trade experience. All these tasks limit the growth rate of exports. Therefore, when desired exports rises above average exports, actual exports is assumed not to rise as much as desired exports. In Figure A.25, MEDEF levels off at 1.10 when  $(DEF/AEF)$  increases above 1.20. Curve MEDEF reflects an assumption that growth of exports in real terms is limited to 10 percent over average export of food AEF.

Average export of food AEF, Equation 184, is a smoothed value of exported food EF. Time to average export of food TAEF, Equation 184.1, is one year. The initial value of average export of food is set equal to 7400 million rials which was the value of exported food in 1959 at 1972 prices.

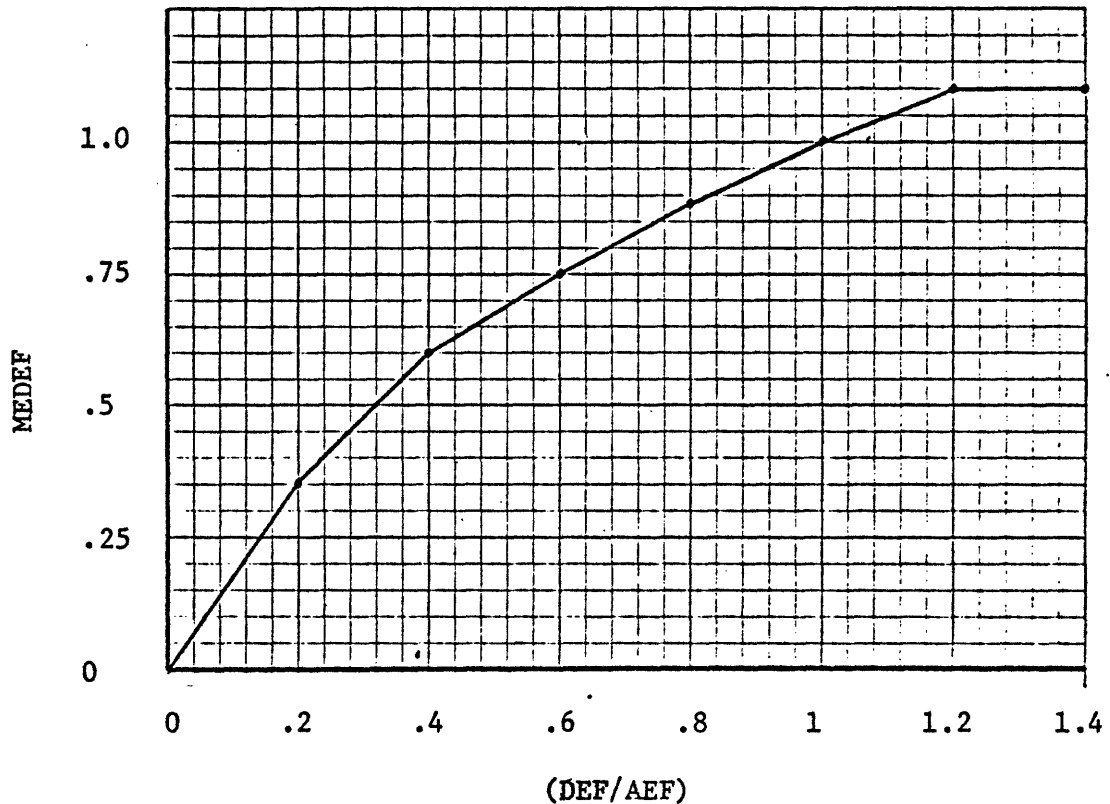

Figure A.25: Multiplier for Export from Desired Export for Food Versus the Ratio of Desired Export of Food to Average Export of Food.

```
MEDEF.K=TABHL(TMEDEF,(DEF.K/AEF.K),0,1.4,.2)           183, A
TMEDEF=0/.35/.6/.75/.88/1/1.10/1.10                 183.1, T
```

MEDEF - MULTIPLIER FOR EXPORT FROM DESIRED EXPORT  
FOR FOOD (DIMENSIONLESS)

TMEDEF - TABLE FOR MULTIPLIER FOR EXPORT FROM  
DESIRED EXPORT FOR FOOD

DEF - DESIRED EXPORT OF FOOD (1E6 RIALS/YEAR)

AEF - AVERAGE EXPORT OF FOOD (1E6 RIALS/YEAR)

```
AEF.K=SMOOTH(EF.K,TAEF)                               184, A
TAEF=1                                                 184.1, C
AEF=7400                                              184.2, N
```

AEF - AVERAGE EXPORT OF FOOD (1E6 RIALS/YEAR)

EF - EXPORTED FOOD (1E6 RIALS/YEAR)

TAEF - TIME TO AVERAGE EXPORT OF FOOD (YEARS)

Desired exported food DEF, Equation 185, is equal to fraction for export of food FEF, times food output FOUT, times multiplier for export from foreign exchange availability MEFEA.

DEF.K=FEF.K\*FOUT.K\*MEFEA.K 185, A  
DEF - DESIRED EXPORT OF FOOD (1E6 RIALS/YEAR)  
FEF - FRACTION FOR EXPORT OF FOOD (DIMENSIONLESS)  
FOUT - FOOD OUTPUT (1E6 RIALS/YEAR)  
MEFEA - MULTIPLIER FOR EXPORT FROM FOREIGN EXCHANGE  
AVAILABILITY (DIMENSIONLESS)

The fraction for export of food FEF, Equation 186, is a function of the ratio of demand output discrepancy to output for food RDODOF. Figure A.26 depicts the functional relationship between FEF and RDODOF. When RDODOF is zero, FEF is set at 0.04. As RDODOF becomes negative, indicating that demand is less than food output, FEF increases above 0.04. When RDODOF is equal to -0.5, indicating that only 50% of food output is domestically demanded, FEF is assumed 0.3. As RDODOF increases, indicating that domestic demand for food is more than food output, FEF falls. When RDODOF is equal to 1.5, FEF is set at 0.01.

The multiplier for export from foreign exchange availability MEFEA, Equation 187, is a function of foreign exchange availability indicator FAVI. Figure A.27 shows the functional relationship between MEFEA and FAVI. When FAVI is one, indicating a normal availability of foreign exchange, MEFEA is one, and the effect of foreign exchange availability on exports of food is neutral. As FAVI increases, the incentive to encourage exportation drops and MEFEA decreases, and vice versa. When FAVI becomes zero, it is assumed that foreign exchange shortage increases desired exports by 50 percent relative to



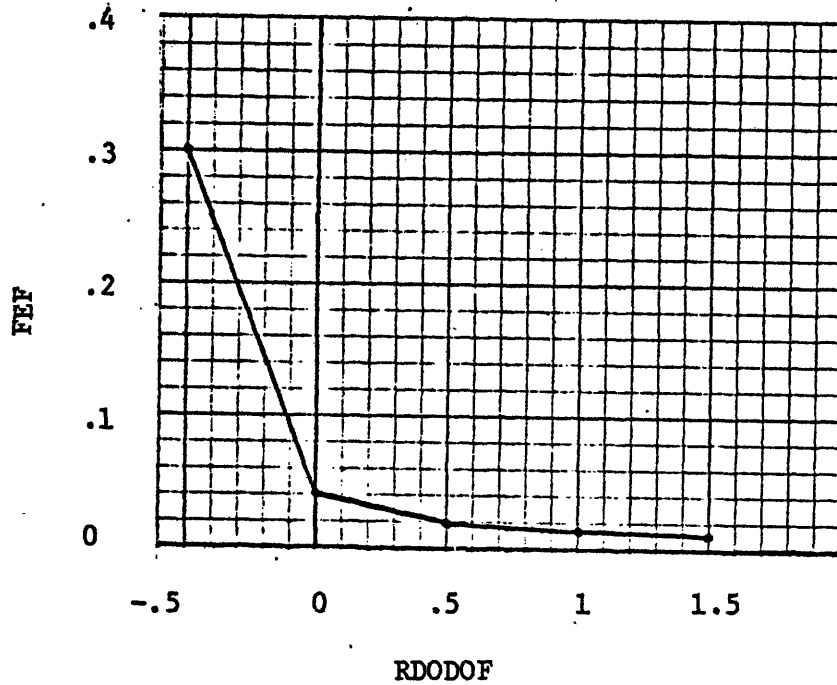

Figure A.26: The Fraction for Export of Food Versus the Ratio of Demand Output Discrepancy to Output for Food.

```
FEF.K=TABHL(TFEF,RDODOF.K,-.5,1.5,.5)           186, A
TFEF=.3/.04/.02/.014/.01                       186.1, T
FEF      - FRACTION FOR EXPORT OF FOOD (DIMENSIONLESS)
TFEF     - TABLE FOR FRACTION OF EXPORT OF FOOD
RDODOF   - RATIO OF DEMAND OUTPUT DISCREPANCY TO
           OUTPUT FOR FOOD (DIMENSIONLESS)
```

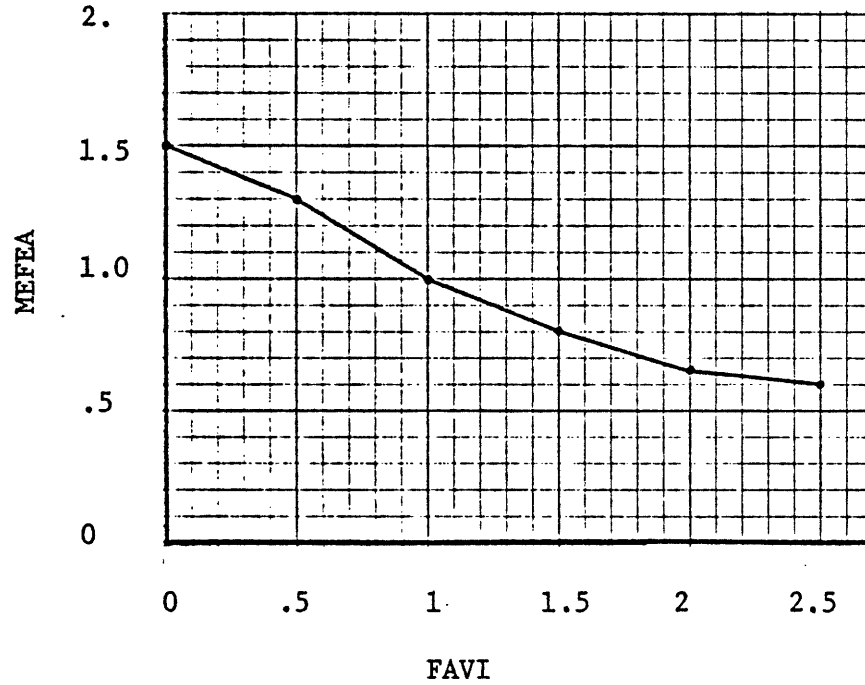

Figure A.27: The Multiplier for Exports from Foreign Exchange Availability Versus Foreign Exchange Availability Indicator.

```
MEFEA.K=TABHL(TMEFEA,FAVI.K,0,2.5,.5)           187, A
TMEFEA=1.5/1.3/1/.8/.65/.6                       187.1, T
MEFEA - MULTIPLIER FOR EXPORT FROM FOREIGN EXCHANGE
        AVAILABILITY (DIMENSIONLESS)
TMEFEA - TABLE FOR MULTIPLIER FOR EXPORT FROM
        FOREIGN EXCHANGE AVAILABILITY
FAVI - FOREIGN EXCHANGE AVAILABILITY INDICATOR
        (DIMENSIONLESS)
```

exports under normal availability of foreign exchange and MEFEA is set at 1.5. When FAVI increases to 2.5, it is assumed that foreign exchange abundance decreases desired exports by 40% relative to exports under normal availability of foreign exchange and MEFEA is set at 0.6.

The following subsections contain the equations for imports and exports of consumption, capital, and intermediate goods. The formulations of imports and exports of all goods are similar to the formulation of trade of food; therefore, the descriptions of the following trade equations are omitted except where parametric differences between the following equations and equations for trade of food exist.

#### A.6.2 Imports and Exports of Consumption Goods

ICONG.K=DICO.K\*MICOFEA.K 189, A  
ICONG - IMPORTED CONSUMPTION GOODS (1E6 RIALS/YEAR)  
DICO - DESIRED IMPORT OF CONSUMPTION GOODS (1E6  
RIALS/YEAR)  
MICOFEA- MULTIPLIER FOR IMPORT OF CONSUMPTION GOODS  
FROM FOREIGN EXCHANGE AVAILABILITY  
(DIMENSIONLESS)

The multiplier for import of consumption goods from foreign exchange availability MICOFEA, Equation 190, is a function of FAVI. Figure A.28 shows the functional relationship between MICOFEA and FAVI. When FAVI is zero, indicating that no foreign exchange is available to pay for imports, MICOFEA is set at zero. As FAVI increases, so does MICOFEA, with a diminishing rate.

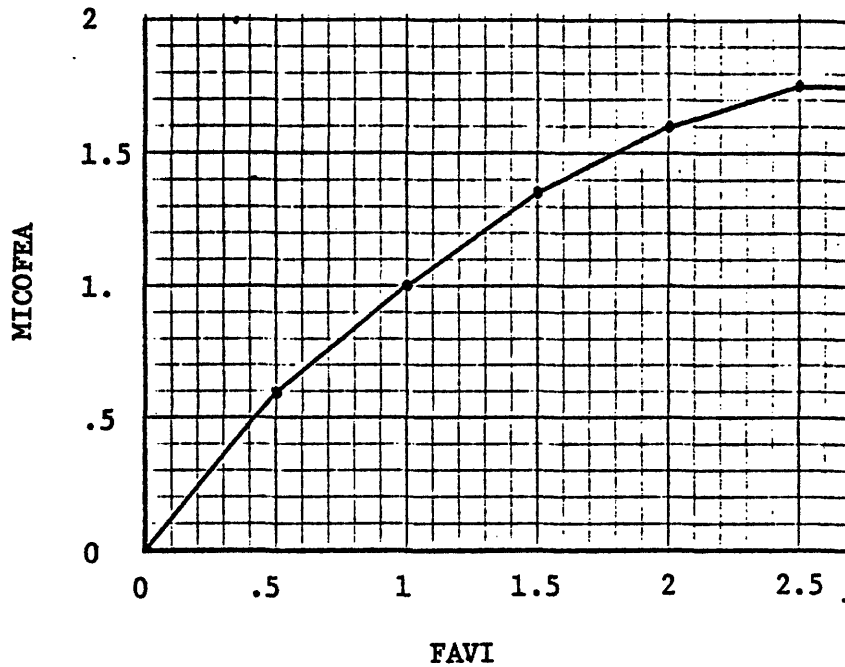

Figure A.28: The Multiplier for Import of Consumption Goods from Foreign Exchange Availability Versus Foreign Exchange Availability Indicator.

MICOFEA.K=TABHL(TMIFEA,FAVI.K,0,2.5,.5) 190, A  
TMIFEA=0/.6/1/1.35/1.6/1.75 190.1, T  
MICOFEA- MULTIPLIER FOR IMPORT OF CONSUMPTION GOODS  
FROM FOREIGN EXCHANGE AVAILABILITY  
(DIMENSIONLESS)  
TMIFEA - TABLE FOR MULTIPLIER FOR IMPORT OF  
CONSUMPTION GOODS FROM FOREIGN EXCHANGE  
AVAILABILITY (DIMENSIONLESS)  
FAVI - FOREIGN EXCHANGE AVAILABILITY INDICATOR  
(DIMENSIONLESS)

DICO.K=FICO.K\*OUTCON.K 191, A  
DICO - DESIRED IMPORT OF CONSUMPTION GOODS (1E6  
RIALS/YEAR)  
FICO - FRACTION FOR IMPORT OF CONSUMPTION GOODS  
(DIMENSIONLESS)  
OUTCON - OUTPUT OF CONSUMPTION GOODS SECTOR (1E6  
RIALS/YEAR)

When FAVI is 1, indicating that the availability of foreign exchange is normal, the effect of foreign exchange availability on imports of consumption goods is assumed to be neutral - i.e., MICOFEA is set at one.

As foreign exchange becomes abundant, the government's expenditures to help the other nations for humanitarian, political, or prestigious reasons can increase; the imports of non-economical goods such as arms can rise. Since foreign aid and arms purchases are expenditures on consumption goods and services, the abundance of foreign exchange reserves can increase the importation of consumption goods and services. The rise in the importation of consumption goods in response to the abundance of foreign exchange depends on the government's policy. In Figure, A.28, as FAVI increases above one, so does MICOFEA. When FAVI becomes 2.5, MICOFEA levels off at 1.75.

The fraction for imports of consumption goods FICO, Equation 192, is a function of the ratio of demand output discrepancy to output for consumption goods RDODOCO and the test of consumption goods importation TCOI to examine different governmental policies. Currently, trade restrictions, in the form

of tariff and import prohibition, on some consumption goods such as cars, refrigerators, air conditioners, and TV sets are very high. On the importation of some other consumption goods such as imported arms by the government and services, there is almost no restriction. On the average, the current trade policy imposes some restrictions on the importation of consumption goods and services. In Figure A.29, Curve A shows the functional relationship between FICO and RDODOCO when TCOI is one. Curve A, in Figure A.29, reflects an import policy which is somewhat restrictive with regard to the importation of consumption goods and services.

As shown in Figure A.29, when RDODOCO is zero, some trade of consumption goods and services is assumed to take place and FICO is set at 0.05. As RDODOCO becomes negative, FICO decreases below 0.05. When RDODOCO is equal to -0.5 and -0.25, FICO is 0.002 and 0.03, respectively. As RDODOCO increases, so does FIF. If there was not any restriction on consumption goods importation, FICO would change along a 45 degree line for the values of RDODOF above .08 to represent the restrictions on the importation of consumption goods and services. For example, when RDODOCO is equal to 0.5 or 1, FICO is equal to 0.35 or 0.75, respectively. If restrictions on the importation of consumption goods increase, the slope of the curve representing the relationship between FICO and RDODOCO should decrease.

Curve B, in Figure 29, shows the relationship between FICO and RDODOCO when the government imposes more restrictions on consumption goods importation than is assumed in Curve A. On Curve B, when RDODOCO is 1 -

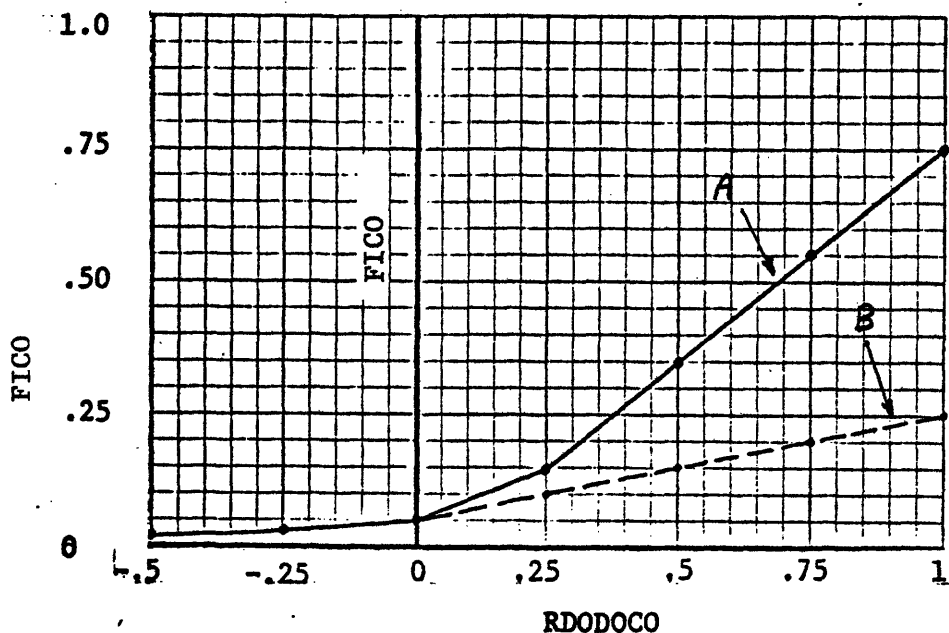

Figure A.29: The Fraction of Imports of Consumption Goods Versus the Ratio of Demand Output Discrepancy to Output for Consumption Goods.

$FICO.K = TCOI.K * TABXT(TFICO, RDODOCO.K, -.5, 1, .25) + (1 - TCOI.K) * TABHL(TFICOT, RDODOCO.K, -.5, 1, .25)$  192, A  
 $TFICO = .02 / .03 / .05 / .15 / .35 / .55 / .75$  192.2, T  
 $TFICOT = .02 / .03 / .05 / .1 / .15 / .20 / .25$  192.3, T  
 FICO - FRACTION FOR IMPORT OF CONSUMPTION GOODS  
 (DIMENSIONLESS)  
 TCOI - TEST OF CONSUMPTION GOODS IMPORT POLICY  
 (DIMENSIONLESS)  
 TFICO - TABLE FOR FRACTION FOR IMPORT OF  
 CONSUMPTION GOODS  
 RDODOCO - RATIO OF DEMAND OUTPUT DISCREPANCY TO  
 OUTPUT FOR CONSUMPTION GOODS  
 (DIMENSIONLESS)  
 TFICOT - TABLE FOR FRACTION FOR IMPORT OF  
 CONSUMPTION GOODS FOR POLICY TEST

i.e., when demand output discrepancy for consumption goods is as much as consumption goods output, FICO is equal to 0.25, indicating that the government allows only 25% of consumption goods and services output to be imported from abroad.

TCOI.K=CLIP(1,TCOIC,1978,TIME.K) 193, A  
TCOIC=1 193.1, C  
TCOI - TEST OF CONSUMPTION GOODS IMPORT POLICY  
(DIMENSIONLESS)  
CLIP - CLIP FUNCTION  
TCOIC - TEST OF CONSUMPTION GOODS IMPORT POLICY  
CONSTANT (DIMENSIONLESS)

RDODOCO.K=DODCO.K/OUTCON.K 194, A  
RDODOCO- RATIO OF DEMAND OUTPUT DISCREPANCY TO  
OUTPUT FOR CONSUMPTION GOODS  
(DIMENSIONLESS)  
DODCO. - DEMAND OUTPUT DISCREPANCY FOR CONSUMPTION  
GOODS (1E6 RIALS/YEAR)  
OUTCON - OUTPUT OF CONSUMPTION GOODS SECTOR (1E6  
RIALS/YEAR)

DODCO.K=DDCONG.K+DDCONS.K-OUTCON.K 195, A  
DODCO - DEMAND OUTPUT DISCREPANCY FOR CONSUMPTION  
GOODS (1E6 RIALS/YEAR)  
DDCONG - DOMESTIC DEMAND FOR CONSUMPTION GOODS (1E6  
RIALS/YEAR)  
DDCONS - DOMESTIC DEMAND FOR CONSTRUCTION (1E6  
RIALS/YEAR)  
OUTCON - OUTPUT OF CONSUMPTION GOODS SECTOR (1E6  
RIALS/YEAR)

ECONG.K=AECO.K\*MEDECO.K 196, A  
ECONG - EXPORTED CONSUMPTION GOODS (1E6 RIALS/YEAR)  
AECO - AVERAGE EXPORT OF CONSUMPTION GOODS (1E6  
RIALS/YEAR)  
MEDECO - MULTIPLIER FOR EXPORT FROM DESIRED EXPORT  
FOR CONSUMPTION GOODS (DIMENSIONLESS)



MEDECO.K=TABHL(TMEDCO,(DECO.K/AECO.K),0,1.4,.2) 197, A  
TMEDCO=0/.35/.6/.75/.88/1/1.10/1.10 197.1, T

- MEDECO - MULTIPLIER FOR EXPORT FROM DESIRED EXPORT  
FOR CONSUMPTION GOODS (DIMENSIONLESS)
- TMEDCO - TABLE FOR MULTIPLIER FOR EXPORT FROM  
DESIRED EXPORT FOR CONSUMPTION GOODS
- DECO - DESIRED EXPORT OF CONSUMPTION GOODS (1E6  
RIALS/YEAR)
- AECO - AVERAGE EXPORT OF CONSUMPTION GOODS (1E6  
RIALS/YEAR)

AECO.K=SMOOTH(ECONG.K,TAECO) 198, A  
TAECO=1 198.1, C  
AECO=5000 198.2, N

- AECO - AVERAGE EXPORT OF CONSUMPTION GOODS (1E6  
RIALS/YEAR)
- ECONG - EXPORTED CONSUMPTION GOODS (1E6 RIALS/YEAR)
- TAECO - TIME TO AVERAGE EXPORT OF CONSUMPTION GOODS  
(YEARS)

DECO.K=FECO.K\*OUTCON.K\*MEFEA.K 199, A

- DECO - DESIRED EXPORT OF CONSUMPTION GOODS (1E6  
RIALS/YEAR)
- FECO - FRACTION FOR EXPORT OF CONSUMPTION GOODS  
(DIMENSIONLESS)
- OUTCON - OUTPUT OF CONSUMPTION GOODS SECTOR (1E6  
RIALS/YEAR)
- MEFEA - MULTIPLIER FOR EXPORT FROM FOREIGN EXCHANGE  
AVAILABILITY (DIMENSIONLESS)

The fraction for export of consumption goods FECO, Equation 200, is a function of the ratio of demand output discrepancy to output for consumption goods RDODOCO. Figure A.30 shows the functional relationship between FECO and RDODOCO. When RDODOCO is zero, FECO is set at 0.08,

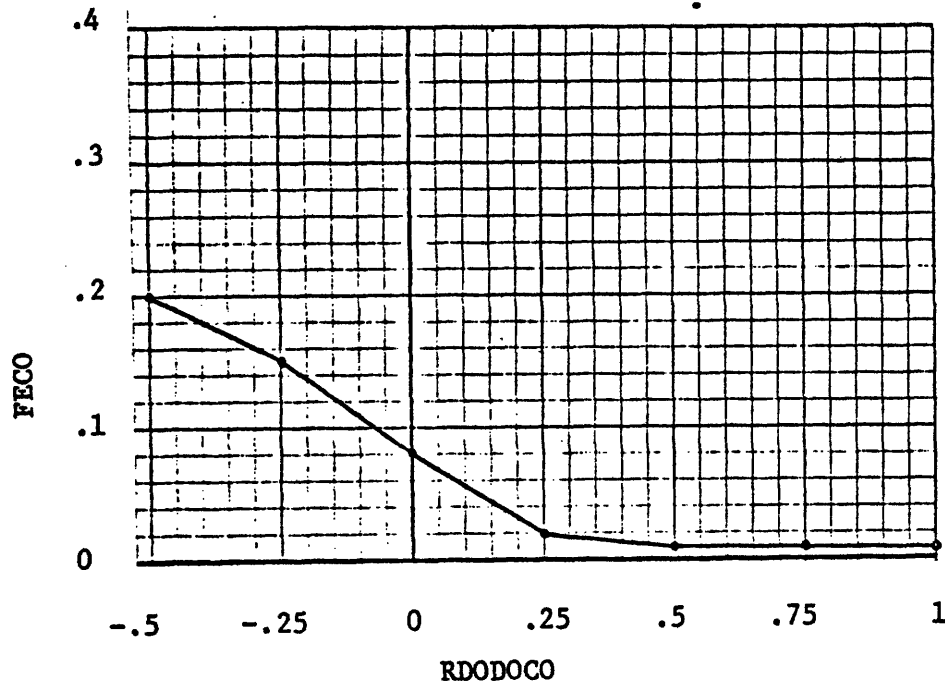

Figure A.30: The Fraction for Export of Consumption Goods Versus the Ratio of Demand Output Discrepancy to Output for Consumption Goods

```
FECO.K=TABHL(TFECO,RDODOCO.K,-.5,1,.25)                200, A
TFECO=.20/.15/.08/.02/.01/.01/.01                    200.1, T
FECO - FRACTION FOR EXPORT OF CONSUMPTION GOODS
(DIMENSIONLESS)
TFECO - TABLE FOR FRACTION FOR EXPORT OF
CONSUMPTION GOODS
RDODOCO- RATIO OF DEMAND OUTPUT DISCREPANCY TO
OUTPUT FOR CONSUMPTION GOODS
(DIMENSIONLESS)
```

which is 0.03 more than the value of the fraction for import of consumption goods FICO for the zero value of RDODOCO. The greater value of FECO relative to FICO at the zero value of RDODOCO is based on the assumption that when demand and output of consumption goods and services are equal, the encouragement of exports and restrictions on imports set the value of exports higher than the value of imports.

In Figure A.30, as RDODOCO becomes negative, FECO increases above 0.08. When RDODOCO is equal to -0.5, FECO is assumed to be 0.20. As RDODOF increases, FECO falls. When RDODOCO is equal to 1, FECO is set at 0.01.

#### A.6.3 Imports and Exports of Capital Goods

ICAPG.K=DICA.K\*MICFEA.K 202, A  
ICAPG - IMPORTED CAPITAL GOODS (1E6 RIALS/YEAR)  
DICA - DESIRED IMPORT OF CAPITAL GOODS (1E6 RIALS/  
YEAR)  
MICFEA - MULTIPLIER FOR IMPORT OF CAPITAL GOODS FROM  
FOREIGN EXCHANGE AVAILABILITY  
(DIMENSIONLESS)

MICFEA.K=TABHL(TMICFE,FAVI.K,0,1,.25) 203, A  
TMICFE=0/.45/.75/.9/1 203.1, T  
MICFEA - MULTIPLIER FOR IMPORT OF CAPITAL GOODS FROM  
FOREIGN EXCHANGE AVAILABILITY  
(DIMENSIONLESS)  
TMICFE - TABLE FOR MULTIPLIER FOR IMPORT OF CAPITAL  
GOODS FROM FOREIGN EXCHANGE AVAILABILITY  
FAVI - FOREIGN EXCHANGE AVAILABILITY INDICATOR  
(DIMENSIONLESS)

DICA.K=FICA.K\*OUTCAP.K 204, A  
DICA - DESIRED IMPORT OF CAPITAL GOODS (1E6 RIALS/  
YEAR)  
FICA - FRACTION FOR IMPORT OF CAPITAL GOODS  
(DIMENSIONLESS)  
OUTCAP - OUTPUT OF CAPITAL GOODS SECTOR(1E6 RIALS/  
YEAR)

The fraction for imports of capital goods, FICA, Equation 205, is a function of the ratio of demand output discrepancy to output for capital goods RDODOCA and test of capital goods importation TCAI to examine different trade restriction of the importation of capital goods. Currently, trade restrictions on the importation of capital goods are almost nonexistent. For the value of TCAI equals one, Curve A, in Figure A.31, shows the functional relationship between FICA and RDODOCA when there is no trade restriction on importation of capital goods.

As shown in Figure A.31, when RDODOCA is equal to 0, FICA is set at 0.1. As RDODOCA becomes negative, FICA decreases below 0.1. When RDODOCA is equal -2, FICA is 0.02. As RDODOCA increases, so does FICA. On Curve A, when RDODOCA is 2, FICA is also 2. As RDODOCA increases above 2, FICA is always equal to RDODOCA, reflecting the lack of any restrictions on capital goods importation.

In Figure A.31, Curve B shows the relationship between FICA and RDODOCA when import restrictions on capital goods exist. The

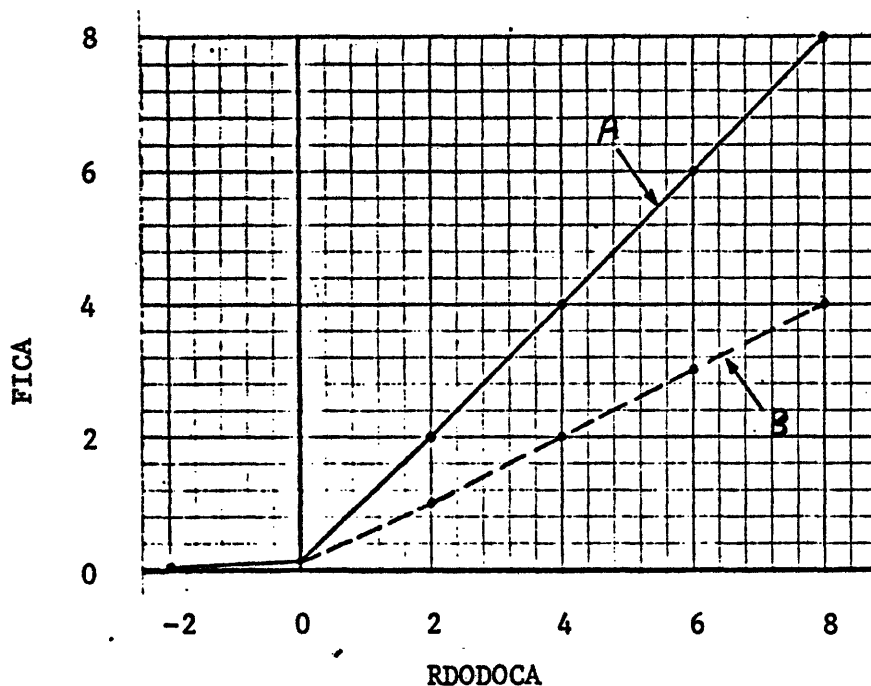

Figure A.31: The Fraction for Imports of Capital Goods Versus the Ratio of Demand Output Discrepancy to Output for Capital Goods.

```

FICA.K=TCAI.K*TABXT(TFICA,RDODOCA.K,-2,8,2)+(1-      205, A
  TCAI.K)*TABHL(TFICAT,RDODOCA.K,-2,8,2)
TFICA=.02/.1/2/4/6/8                                205.2, T
TFICAT=.02/.1/1/2/3/4                               205.3, T
FICA      - FRACTION FOR IMPORT OF CAPITAL GOODS
            (DIMENSIONLESS)
TCAI      - TEST OF CAPITAL GOODS IMPORT POLICY
            (DIMENSIONLESS)
TFICA     - TABLE FOR DESIRED IMPORT OF CAPITAL GOODS
RDODOCA-  RATIO OF DEMAND OUTPUT DISCREPANCY TO
            OUTPUT FOR CAPITAL GOODS (DIMENSIONLESS)
TFICAT    - TABLE FOR DESIRED IMPORT OF CAPITAL GOODS
            FOR POLICY TEST
    
```

relationship shown by Curve B is used in the model when the value of TCAI is zero. The relationship shown by Curve B can be used to examine a policy restricting the importation of capital goods. Curve B, for positive values of RDODOCA, lies below Curve A. When RDODOCA is 8, FICA is 4, indicating that the government regulates the importation of capital goods such that the desired import of capital goods is four times domestic output while demand output discrepancy for capital goods is 8 times output.

TCAI.K=CLIP(1,TCAIC,1978,TIME.K) 206, A  
TCAIC=1 206.1, C  
TCAI - TEST OF CAPITAL GOODS IMPORT POLICY  
(DIMENSIONLESS)  
CLIP - CLIP FUNCTION  
TCAIC - TEST OF CAPITAL GOODS IMPORT POLICY  
CONSTANT (DIMENSIONLESS)

RDODOCA.K=DODCA.K/OUTCAP.K 207, A  
RDODOCA- RATIO OF DEMAND OUTPUT DISCREPANCY TO  
OUTPUT FOR CAPITAL GOODS (DIMENSIONLESS)  
DODCA - DEMAND OUTPUT DISCREPANCY FOR CAPITAL GOODS  
(1E6 RIALS/YEAR)  
OUTCAP - OUTPUT OF CAPITAL GOODS SECTOR(1E6 RIALS/  
YEAR)

DODCA.K=DDCAPG.K-OUTCAP.K 208, A  
DODCA - DEMAND OUTPUT DISCREPANCY FOR CAPITAL GOODS  
(1E6 RIALS/YEAR)  
DDCAPG - DOMESTIC DEMAND FOR CAPITAL GOODS (1E6  
RIALS/YEAR)  
OUTCAP - OUTPUT OF CAPITAL GOODS SECTOR(1E6 RIALS/  
YEAR)

ECAPG.K=AECA.K\*MEDECA.K 209, A  
ECAPG - EXPORTED CAPITAL GOODS (1E6 RIALS/YEAR)  
AECA - AVERAGE EXPORT OF CAPITAL GOODS (1E6 RIALS/  
YEAR)  
MEDECA - MULTIPLIER FOR EXPORT FROM DESIRED EXPORT  
FOR CAPITAL GOODS (DIMENSIONLESS)

MEDECA.K=TABHL(TMEDCA,(DECA.K/AECA.K),0,1.4,.2) 210, A  
TMEDCA=0/.35/.6/.75/.88/1/1.10/1.10 210.1, T  
MEDECA - MULTIPLIER FOR EXPORT FROM DESIRED EXPORT  
FOR CAPITAL GOODS (DIMENSIONLESS)  
DECA - DESIRED EXPORT OF CAPITAL GOODS (1E6 RIALS/  
YEAR)  
AECA - AVERAGE EXPORT OF CAPITAL GOODS (1E6 RIALS/  
YEAR)

AECA.K=SMOOTH(ECAPG.K,TAECA) 211, A  
TAECA=1 211.1, C  
AECA=20 211.2, N  
AECA - AVERAGE EXPORT OF CAPITAL GOODS (1E6 RIALS/  
YEAR)  
ECAPG - EXPORTED CAPITAL GOODS (1E6 RIALS/YEAR)  
TAECA - TIME TO AVERAGE EXPORT OF CAPITAL GOODS  
(YEARS)

DECA.K=FECA.K\*OUTCAP.K\*MEFEA.K 212, A  
DECA - DESIRED EXPORT OF CAPITAL GOODS (1E6 RIALS/  
YEAR)  
FECA - FRACTION FOR EXPORT OF CAPITAL GOODS  
(DIMENSIONLESS)  
OUTCAP - OUTPUT OF CAPITAL GOODS SECTOR(1E6 RIALS/  
YEAR)  
MEFEA - MULTIPLIER FOR EXPORT FROM FOREIGN EXCHANGE  
AVAILABILITY (DIMENSIONLESS)

The fraction for export of capital goods FECA is a function of the ratio of demand output discrepancy to output for capital goods RDODOCA. Figure A.32 shows the functional relationship between FECA and RDODOCA. When RDODOCA is -2, FECA is assumed to be 1.2. As RDODOCA increases, FECA decreases. When RDODOCA is zero, FECA is 0.1. When RDODOCA is equal to 2, 4, 6, and 8, the values of FECA are set at 0.05, 0.04, 0.035, and .03, respectively.

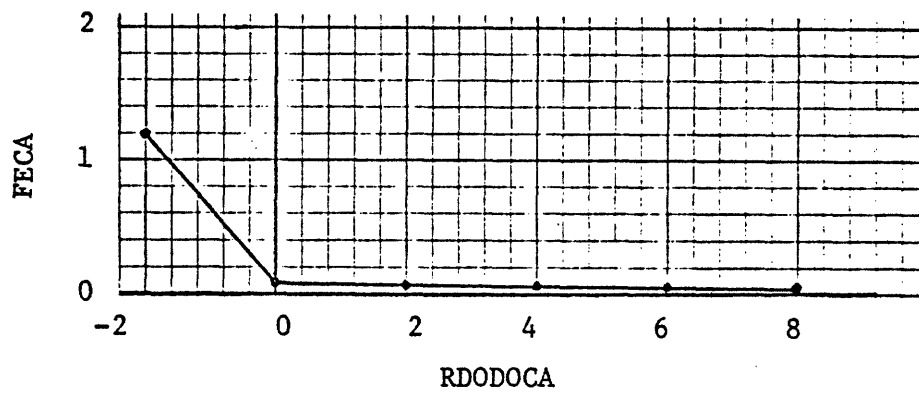

Figure A.32: The Fraction for Export of Capital Goods Versus the Ratio of Demand Output Discrepancy to Output for Capital Goods.

FECA.K=TABHL(TFECA,RDODOCA.K,-2,8,2) 213, A  
TFECA=1.2/.1/.05/.04/.035/.03 213.1, T  
FECA - FRACTION FOR EXPORT OF CAPITAL GOODS  
(DIMENSIONLESS)  
TFECA - TABLE FOR FRACTION FOR EXPORT OF CAPITAL  
GOODS  
RDODOCA- RATIO OF DEMAND OUTPUT DISCREPANCY TO  
OUTPUT FOR CAPITAL GOODS (DIMENSIONLESS)



A.6.4 Imports and Exports of Intermediate Goods

IIG.K=DII.K\*MIIFEA.K 215, A  
IIG - IMPORTED INTERMEDIATE GOODS (1E6 RIALS/  
YEAR)  
DII - DESIRED IMPORT OF INTERMEDIATE GOODS (1E6  
RIALS/YEAR)  
MIIFEA - MULTIPLIER FOR IMPORTED INTERMEDIATE GOODS  
FROM FOREIGN EXCHANGE AVAILABILITY  
(DIMENSIONLESS)

MIIFEA.K=TABHL(TMIIFE,FAVI.K,0,1,.25) 216, A  
TMIIFE=0/.45/.75/.9/1 216.1, T  
MIIFEA - MULTIPLIER FOR IMPORTED INTERMEDIATE GOODS  
FROM FOREIGN EXCHANGE AVAILABILITY  
(DIMENSIONLESS)  
TMIIFE - TABLE FOR MULTIPLIER FOR IMPORT OF  
INTERMEDIATE GOODS FROM FOREIGN EXCHANGE  
AVAILABILITY  
FAVI - FOREIGN EXCHANGE AVAILABILITY INDICATOR  
(DIMENSIONLESS)

---

DII.K=FII.K\*OUTI.K 217, A  
DII - DESIRED IMPORT OF INTERMEDIATE GOODS (1E6  
RIALS/YEAR)  
FII - FRACTION FOR IMPORT OF INTERMEDIATE GOODS  
(DIMENSIONLESS)  
OUTI - OUTPUT OF INTERMEDIATE GOODS SECTOR (1E6  
RIALS/YEAR)

The fraction for import of intermediate goods FII is a function of the ratio of demand output discrepancy to output for intermediate goods RDODOI. Figure A.33 shows the functional relationship between FII and RDODOI for two alternative policies. Curve A reflects a trade policy which does not impose any restriction on importation of intermediate

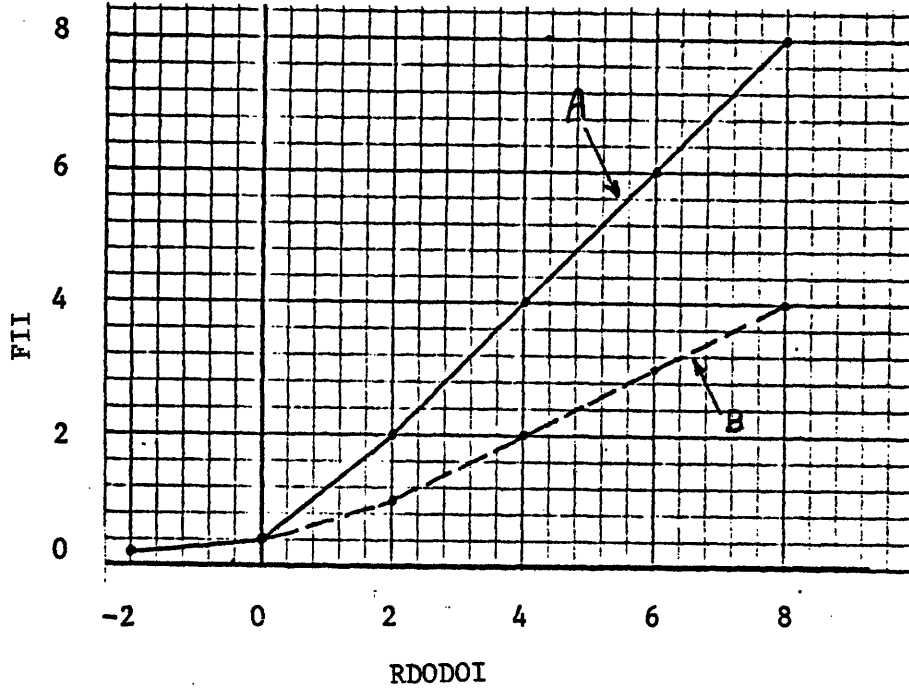

Figure A.33: The Fraction for Import of Intermediate Goods Versus the Ratio of Demand Output Discrepancy to Output for Intermediate Goods

$FII.K = TII.K * TABXT(TFII, RDODOI.K, -2, 8, 2) + (1 - TII.K) * TABHL(TFIIT, RDODOI.K, -2, 8, 2)$       218, A  
 $TFII = .2 / .4 / 2 / 4 / 6 / 8$       218.2, T  
 $TFIIT = .2 / .4 / 1 / 2 / 3 / 4$       218.3, T

**FII**      - FRACTION FOR IMPORT OF INTERMEDIATE GOODS  
 (DIMENSIONLESS)

**TII**      - TEST OF INTERMEDIATE GOODS IMPORT POLICY  
 (DIMENSIONLESS)

**TFII**      - TABLE FOR FRACTION FOR IMPORT OF  
 INTERMEDIATE GOODS

**RDODOI**      - RATIO OF DEMAND OUTPUT DISCREPANCY TO  
 OUTPUT FOR INTERMEDIATE GOODS  
 (DIMENSIONLESS)

**TFIIT**      - TABLE FOR FRACTION FOR IMPORT OF  
 INTERMEDIATE GOODS FOR POLICY TEST

goods. Curve B represents a restrictive trade policy. The two trade policies can be examined in the simulation of the model. When RDODOI is zero - i.e., when demand for intermediate goods is equal to the domestic output - FII is assumed to be 0.4.

The intermediate goods sector includes mining activities. As in other developing countries, most of raw materials produced in Iran are exported, while unfinished goods and required but nationally scarce raw materials are imported. The trade of raw materials and unfinished goods is high relative to total intermediate goods. Therefore, in Figure A.33, when RDODOI is equal to zero or -2, FII is assumed to be 0.4 and 0.2, respectively.

TII.K=CLIP(1, TIIC, 1978, TIME.K) 219, A  
TIIC=1 219.1, C  
TII - TEST OF INTERMEDIATE GOODS IMPORT POLICY  
(DIMENSIONLESS)  
CLIP - CLIP FUNCTION  
TIIC - TEST OF INTERMEDIATE GOODS IMPORT POLICY  
COONSTANT (DIMENSIONLESS)

RDODOI.K=DODI.K/OUTI.K 220, A  
RDODOI - RATIO OF DEMAND OUTPUT DISCREPANCY TO  
OUTPUT FOR INTERMEDIATE GOODS  
(DIMENSIONLESS)  
DODI - DEMAND OUTPUT DISCREPANCY FOR INTERMEDIATE  
GOODS (1E6 RIALS/YEAR)  
OUTI - OUTPUT OF INTERMEDIATE GOODS SECTOR (1E6  
RIALS/YEAR)

DODI.K=DDIG.K-OUTI.K 221, A  
DODI - DEMAND OUTPUT DISCREPANCY FOR INTERMEDIATE  
GOODS (1E6 RIALS/YEAR)  
DDIG - DOMESTIC DEMAND FOR INTERMEDIATE GOODS (1E6  
RIALS/YEAR)  
OUTI - OUTPUT OF INTERMEDIATE GOODS SECTOR (1E6  
RIALS/YEAR)

FIG.K=AEI.K\*MEDEI.K 222, A  
EIG - EXPORTED INTERMEDIATE GOODS (1E6 RIALS/  
YEAR)  
AEI - AVERAGE EXPORT OF INTERMEDIATE GOODS (1E6  
RIALS/YEAR)  
MEDEI - MULTIPLIER FOR EXPORT FROM DESIRED EXPORT  
FOR INTERMEDIATE GOODS (DIMENSIONLESS)

MEDEI.K=TABHL(TMEDEI, (DEI.K/AEI.K), 0, 1.4, .2) 223, A  
TMEDEI=0/.35/.6/.75/.88/1/1.10/1.10 223.1, T  
MEDEI - MULTIPLIER FOR EXPORT FROM DESIRED EXPORT  
FOR INTERMEDIATE GOODS (DIMENSIONLESS)  
TMEDEI - TABLE FOR MULTIPLIER FOR EXPORT FROM  
DESIRED EXPORT FOR INTERMEDIATE GOODS  
DEI - DESIRED EXPORT OF INTERMEDIATE GOODS (1E6  
RIALS/YEAR)  
AEI - AVERAGE EXPORT OF INTERMEDIATE GOODS (1E6  
RIALS/YEAR)

AEI.K=SMOOTH(EIG.K, TAEXI) 224, A  
TAEXI=1 224.1, C  
AEI=1300 224.2, N  
AEI - AVERAGE EXPORT OF INTERMEDIATE GOODS (1E6  
RIALS/YEAR)  
EIG - EXPORTED INTERMEDIATE GOODS (1E6 RIALS/  
YEAR)  
TAEXI - TIME TO AVERAGE EXPORT OF INTERMEDIATE  
GOODS (YEARS)

DEI.K=FEI.K\*OUTI.K\*MEFEA.K 225, A  
DEI - DESIRED EXPORT OF INTERMEDIATE GOODS (1E6  
RIALS/YEAR)  
FEI - FRACTION FOR EXPORT OF INTERMEDIATE GOODS  
(DIMENSIONLESS)  
OUTI - OUTPUT OF INTERMEDIATE GOODS SECTOR (1E6  
RIALS/YEAR)  
MEFEA - MULTIPLIER FOR EXPORT FROM FOREIGN EXCHANGE  
AVAILABILITY (DIMENSIONLESS)

The fraction for export of intermediate goods FEI, Equation 226, is a function of the ratio of demand output discrepancy to output for intermediate goods RDODOI. Figure A.34 shows the functional relationship between FEI and RDODOI. When RDODOI is -2, FEI is assumed to be 1.5. As RDODOI increases, FEI decreases. When RDODOI is equal to zero, FEI is set at 0.4, the same as the correspondent value for FII when RDODOI is equal to zero in Figure A.40. Therefore, when demand and output of intermediate goods are equal in the country, 40% of output is desired to be traded. As RDODOI increases above zero, FEI drops below 0.4. When RDODOI is equal to 2, 4, 6, and 8, FEI is set at 0.25, 0.15, 0.12, and 0.1, respectively.

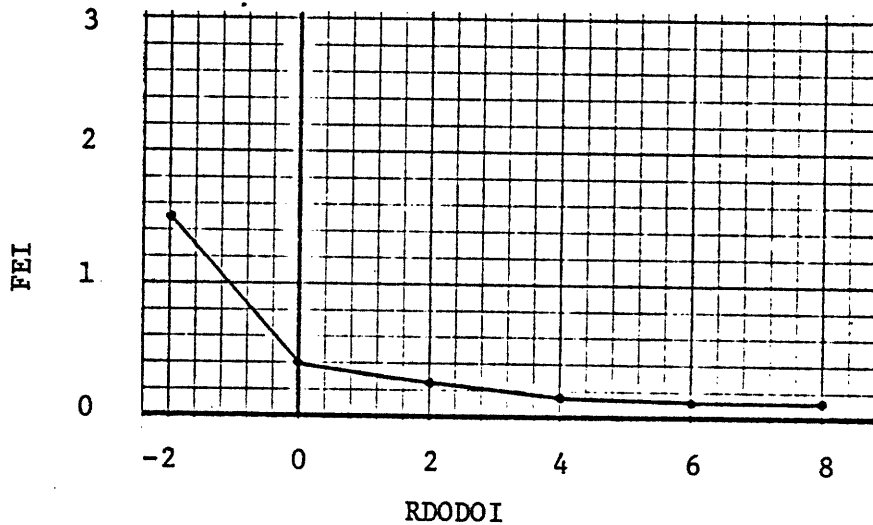

Figure A.41: The Fraction for Export of Intermediate Goods Versus the Ratio of Demand Output discrepancy to Output for Intermediate Goods.

FEI.K=TABHL(TFEI,RDODOI.K,-2,8,2) 226, A  
TFEI=1.5/.4/.25/.15/.12/.10 226.1, T  
FEI - FRACTION FOR EXPORT OF INTERMEDIATE GOODS  
(DIMENSIONLESS)  
TFEI - TABLE FOR FRACTION FOR EXPORT OF  
INTERMEDIATE GOODS  
RDODOI - RATIO OF DEMAND OUTPUT DISCREPANCY TO  
OUTPUT FOR INTERMEDIATE GOODS  
(DIMENSIONLESS)

#### A.7 OIL EXPORTATION

Oil reserves OIL, Equation 228, are depleted by oil exports OILEX and domestic oil consumption DOCON. The initial value of oil reserves OILN is assumed to be 100 billion barrels of oil. According to Oil and Gas Journal December 27, 1976, p. 104, proven oil reserves in Iran on January 1, 1977 was 63 billion barrels. From 1959 to 1974, accumulated oil production had been 20.825 billion barrels. Therefore, the reserves in 1959 had been  $63 + 20.825 = 83.825$  billion barrels. However, oil reserves initial OILN, Equation 228.2, is set at 100 billion barrels in order (1) to account for possible reserves which might be found in the future, and (2) to account for possible natural gas exports during the simulation.

OIL.K=OIL.J+DT\*(-OILEX.JK-DOCON.JK) 228, L  
OIL=OILN 228.1, N  
OILN=100 228.2, C  
OIL - OIL RESERVES (1E9 BARRELS)  
OILEX - OIL EXPORTS (1E9 BARRELS/YEAR)  
DOCON - DOMESTIC OIL CONSUMPTION (1E9 BARRELS/YEAR)  
OILN - OIL RESERVES INITIAL (1E9 BARRELS)

Oil exports OILEX, Equation 229, is set equal to exogenous demand for oil EDO from 1959 to 1977. Exogenous demand for oil EDO, Equation 230, represents the actual oil exports during 1959-1977. After 1977, oil exports OILEX is equal to exports of oil EO, which is determined endogenously in the model. In order to switch OILEX from EDO to EO in 1977, in the CLIP function of Equation 229, time to switch to endogenous oil exports TSEOS is set at 1977 in Equation 229.1.

OILEX.KL=CLIP(-EDO.K,EO.K,TSEOE,TIME.K)	229, R
TSEOE=1977	229.1, C
OILEX - OIL EXPORTS (1E9 BARRELS/YEAR)	
CLIP - CLIP FUNCTION	
EDO - EXOGENOUSE DEMAND FOR OIL (1E9 BARRELS/ YEAR)	
EO - EXPORT OF OIL (1E9 BARRELS/YEAR)	
TSEOE - TIME TO SWITCH TO ENDOGENOUS OIL EXPORTS (YEARS)	
EDO.K=TABHL(TEDO,TIME.K,1959,1977,2)	230, A
TEDO=.327/.4104/.512/.6518/.9008/1.1726/1.5978/ 2.045/1.7617/2.1	230.1, T
EDO - EXOGENOUSE DEMAND FOR OIL (1E9 BARRELS/ YEAR)	
TEDO - TABLE FOR EXOGENOUSE DEMAND FOR OIL	

Exports of oil EO, Equation 231, is equal to average exports of oil AEO times multiplier for oil exports from desired export MOEDE.

$$EO.K = AEO.K * MOEDE.K \quad 231, A$$

EO - EXPORT OF OIL (1E9 BARRELS/YEAR)  
AEO - AVERAGE EXPORT OF OIL (1E9 BARRELS/YEAR)  
MOEDE - MULTIPLIER FOR OIL EXPORTS FROM DESIRED EXPORT (DIMENSIONLESS)

The multiplier for oil exports from desired export MOEDE, Equation 232, is a function of the ratio of desired exports of oil DEO to average exports of oil AEO. Figure A.35 shows the functional relationship between MOEDE and (DEO/AEO). When DEO rises relative to AEO, MOEDE increases to raise oil exports. Because international demand for oil is growing and, in the future, there will be no restriction on oil exports from the demand side, expansion of oil exports in response to desired exports is a matter of governmental policy. Figure A.35 shows two alternative policies. On Curve A, which is a 45 degree line, MOEDE is always equal to (DEO/AEO). Curve A represents a policy according to which oil exports will always be equal to desired exports of oil. However, on Curve B, MOEDE is equal to (DEO/AEO) up to the point where (DEO/AEO) becomes 1.02. MOEDE does not rise when (DEO/AEO) exceeds 1.02. Curve B represents a policy according to which oil exports can not rise more than 2 percent of average export of oil AEO in each year. Because AEO is a two years average of oil exports, the policy represented



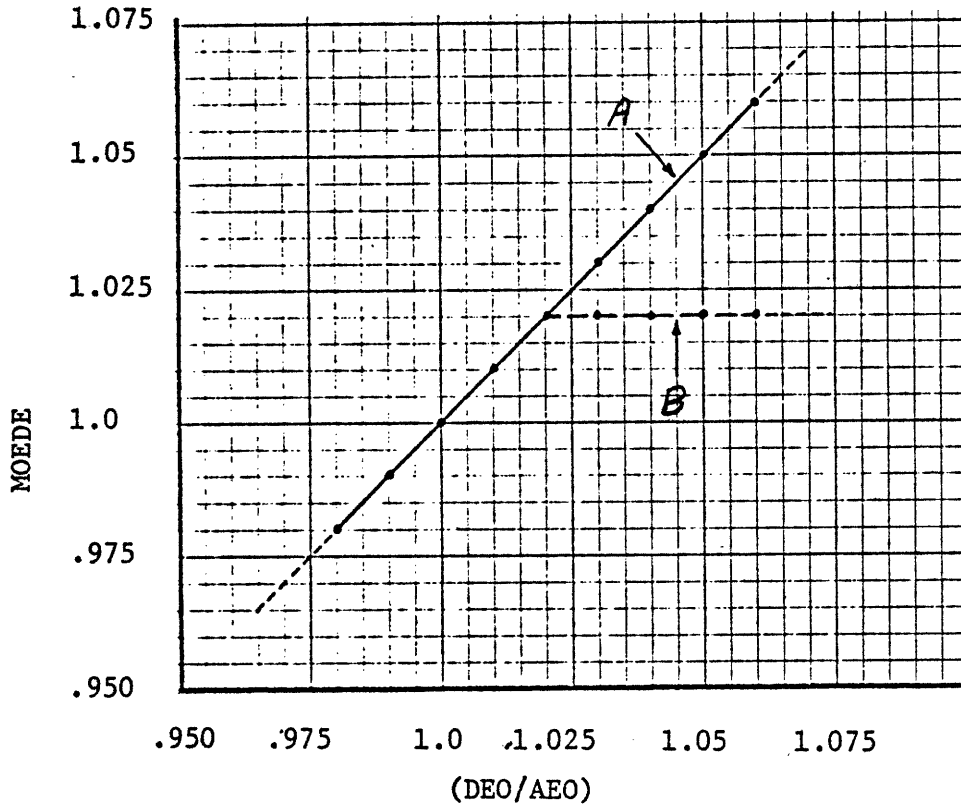

Figure A.35: Multiplier for Oil Exports from Desired Export Versus the Ratio of Desired Exports of Oil to Average Exports of Oil.

```
MOEDE.K=TABXT(TMOEDE,(DEO.K/AEO.K),.98,1.06,.01)      232, A
TMOEDE=.98/.99/1/1.01/1.02/1.03/1.04/1.05/1.06      232.1, T
MOEDE - MULTIPLIER FOR OIL EXPORTS FROM DESIRED
        EXPORT (DIMENSIONLESS)
TMOEDE - TABLE FOR MULTIPLIER FOR OIL EXPORTS FROM
        DESIRED EXPORT
DEO     - DESIRED EXPORTS OF OIL (1E9 BARRELS/YEAR)
AEO     - AVERAGE EXPORT OF OIL (1E9 BARRELS/YEAR)
```

by Curve B limits growth of oil exports at one percent per year. The two alternative policies are examined in Chapters 4 and 5.

Desired exports of oil DEO, Equation 233, is equal to average export of oil AEO times multiplier for export of oil from reserves MEOR times multiplier for export of oil from foreign exchange availability.

$$\text{DEO.K} = \text{AEO.K} * \text{MEOR.K} * \text{MEOFA.K} \quad 233, A$$

DEO - DESIRED EXPORTS OF OIL (1E9 BARRELS/YEAR)  
AEO - AVERAGE EXPORT OF OIL (1E9 BARRELS/YEAR)  
MEOR - MULTIPLIER FOR EXPORT OF OIL FROM RESERVES  
(DIMENSIONLESS)  
MEOFA - MULTIPLIER FOR EXPORT OF OIL FROM FOREIGN  
EXCHANGE AVAILABILITY (DIMENSIONLESS)

The multiplier for export of oil from foreign exchange availability MEOFA, Equation 234, is a function of foreign exchange availability indicator FAVI. Figure A.36 shows the functional relationship between MEOFA and FAVI. When FAVI is one, indicating that foreign exchange availability is normal, MEOFA is one and the effect of foreign exchange availability on oil exportation is neutral. When a foreign exchange shortage appears, pressures to increase oil exports and restore foreign exchange availability rise. Therefore, as FAVI decreases below 1, MEOFA increases. However, as the foreign exchange shortage worsens, its marginal effect on oil exports diminishes because of physical limitations as well as the government's reluctance to maintain a

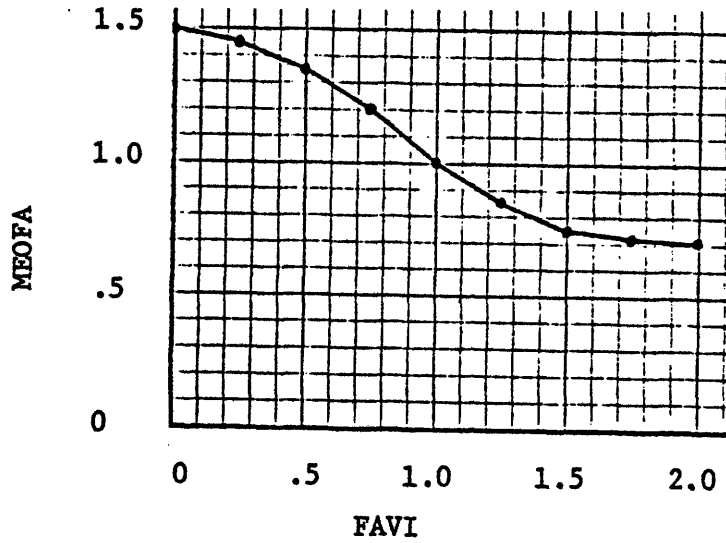

Figure A.36: The Multiplier for Export of Oil From Foreign Exchange Availability Versus Foreign Exchange Availability Indicator.

MEOFA.K=TABHL(TMEOF,FAVI.K,0,2,.25) 234, A  
TMEOF=1.5/1.45/1.35/1.2/1/.85/.75/.72/.7 234.1, T  
MEOFA - MULTIPLIER FOR EXPORT OF OIL FROM FOREIGN EXCHANGE AVAILABILITY (DIMENSIONLESS)  
TMEOF - TABLE FOR MULTIPLIER FOR EXPORT OF OIL FROM FOREIGN EXCHANGE AVAILABILITY  
FAVI - FOREIGN EXCHANGE AVAILABILITY INDICATOR (DIMENSIONLESS)

very rapid growth of oil exports. In the extreme, when FAVI is zero, MEOFA is assumed to be 1.5. In the other direction, when foreign exchange is abundant and FAVI increases above 1, MEOFA drops below one with a diminishing rate. When FAVI becomes 2, MEOFA levels off at 0.7.

The multiplier for export of oil from reserves MEOR, Equation 235, is a function of the ratio of oil reserves OIL to required reserves for normal coverage RRNC. Figure A.37 shows the functional relationship between MEOR and OIL/RRNC. When (OIL/RRNC) is more than one and oil is abundantly available, MEOR increases above one to raise oil exports and, therefore, oil revenues and national income. In Figure A.37, MEOR levels off at 1.10, assuming that abundancy of oil reserves would result in a 10 percent growth of desired export over average export of oil AEO. A 10 percent growth of DEO over AEO is equivalent to a 5 percent annual growth of DEO because AEO represents the average of exports over a two years period. In Figure A.37, as (OIL/RRNC) decreases, so does MEOR. When oil runs out and OIL/RRNC becomes zero, MEOR levels off at zero.

The required reserves for normal coverage RRNC, Equation 236, is equal to normal reserves coverage time NRC times the sum of average exports of oil AEO and domestic oil consumption DOCON.

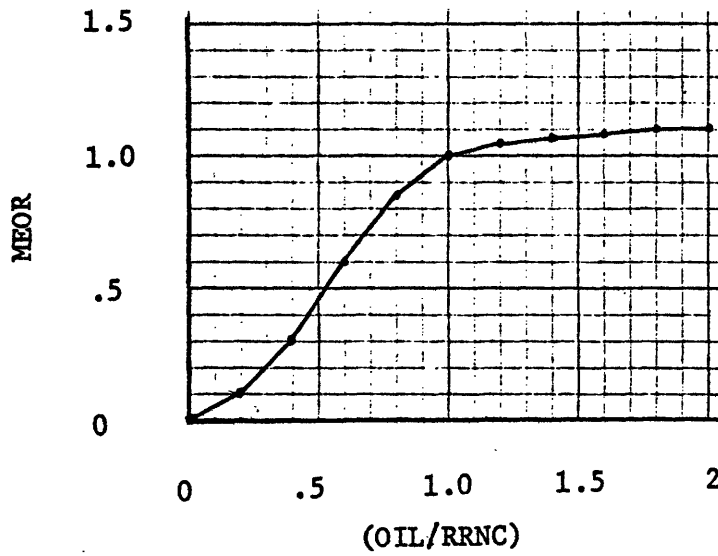

Figure A.37: Multiplier for Export of Oil from Reserves Versus the Ratio of Oil Reserves to Required Reserves for Normal Coverage.

```
MEOR.K=TABHL(TMEOR,(OIL.K/RRNC.K),0,2,.2)          235, A
TMEOR=0/.1/.3/.6/.85/1/1.04/1.07/1.09/1.10/1.10  235.1, T
MEOR      - MULTIPLIER FOR EXPORT OF OIL FROM RESERVES
            (DIMENSIONLESS)
TMEOR     - TABLE FOR MULTIPLIER FOR EXPORT OF OIL FROM
            RESERVES
OIL       - OIL RESERVES (1E9 BARRELS)
RRNC      - REQUIRED RESERVES FOR NORMAL COVERAGE (1E9
            BARRELS/YEAR)
```

RRNC.K=(DOCON.JK+AEO.K)\*NRC 236, A  
RRNC - REQUIRED RESERVES FOR NORMAL COVERAGE (1E9  
BARRELS/YEAR)  
DOCON - DOMESTIC OIL CONSUMPTION (1E9 BARRELS/YEAR)  
AEO - AVERAGE EXPORT OF OIL (1E9 BARRELS/YEAR)  
NRC - NORMAL RSERVES COVERAGE TIME (YEARS)

The average exports of oil AEO, Equation 237, is a smoothed value of oil exports OILEX. Time to average exports of oil TAE0 is set at 2 years. The initial value of average exports of oil in Equation 237.2 is set at 0.32, which was oil exports in 1959.

AEO.K=SMOOTH(OILEX.JK,TAE0) 237, A  
TAE0=2 237.1, C  
AEO=.32 237.2, N  
AEO - AVERAGE EXPORT OF OIL (1E9 BARRELS/YEAR)  
OILEX - OIL EXPORTS (1E9 BARRELS/YEAR)  
TAE0 - TIME TO AVERAGE EXPORT OF OIL (YEARS)

Domestic oil consumption DOCON, Equation 238, is equal to domestic demand for energy DDE times multiplier for domestic oil consumption from oil availabilty MDCOA times the ratio of non-oil output N00 to potential non-oil output PNO0. Domestic demand for energy DDE is formulated based on potential non-oil output PNO0 in Equation 67. However, due to different factors such as lack of experience, a possible intermediate goods shortage or a low aggregate demand, actual non-oil output might be less than PNO0. As a result, actual energy consumption might be less than DDE. Therefore, domestic demand for energy is

multiplied by the ratio of non-oil output NOO to potential non-oil output in order to calculate domestic oil consumption DOCON.

$$\text{DOCON.KL} = \text{DDE.K} * \text{MDOCA.K} * (\text{NOO.K} / \text{PNOO.K}) \quad 238, R$$

DOCON - DOMESTIC OIL CONSUMPTION (1E9 BARRELS/YEAR)  
DDE - DOMESTIC DEMAND FOR ENERGY (1E9 BARRELS OF OIL/YEAR)  
MDOCA - MULTIPLIER FOR DOMESTIC OIL CONSUMPTION FROM AVAILABILITY (DIMENSIONLESS)  
NOO - NON-OIL OUTPUT (1E6 RIALS/YEAR)  
PNOO - POTENTIAL NON-OIL OUTPUT (1E6 RIALS/YEAR)

The multiplier for oil consumption from oil availability MDOCA is a function of the oil availability indicator OAVI. Figure A.38 shows the functional relationship between MDOCA and OAVI. When OAVI is more than one, MDOCA is one. As OAVI decreases below one, so does MDOCA. When OAVI becomes zero, MDOCA levels off at zero.

Oil revenues OILREV, Equation 240, is equal to oil exports OILEX times oil price OILP.

$$\text{OILREV.K} = \text{OILEX.JK} * \text{OILP.K} * 1000 \quad 240, A$$

OILREV - OIL REVENUES (1E6 RIALS/YEAR)  
OILEX - OIL EXPORTS (1E9 BARRELS/YEAR)  
OILP - OIL PRICE (RIALS/BARRELS)

Oil price OILP, Equation 241, is exogenous to the model. Figure A.39 shows the income of the Iranian government per barrel of oil from 1958 through 1976 in 1972 rials. The numbers for oil price in Figure A.39 are obtained by deflating the ratio of the government's oil revenues

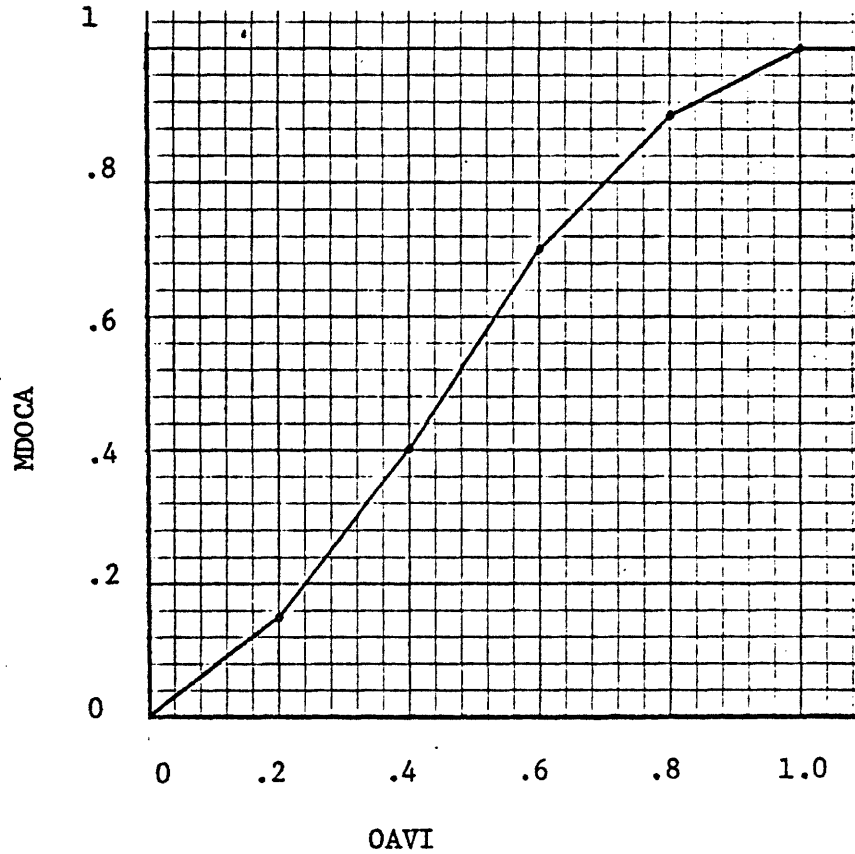

Figure A.38: The Multiplier for Domestic Oil Consumption from Oil Availability Versus Oil Availability Indicator.

```
MDOCA.K=TABHL(TMDOCA,OAVI.K,0,1,.2)           239, A
TMDOCA=0/.15/.4/.7/.9/1                       239.1, T
MDOCA - MULTIPLIER FOR DOMESTIC OIL CONSUMPTION
        FROM AVAILABILITY (DIMENSIONLESS)
TMDOCA - TABLE FOR MULTIPLIER FOR DOMESTIC OIL
        CONSUMPTION FROM AVAILABILITY
        (DIMENSIONLESS)
OAVI - OIL AVAILABILITY INDICATOR (DIMENSIONLESS)
```



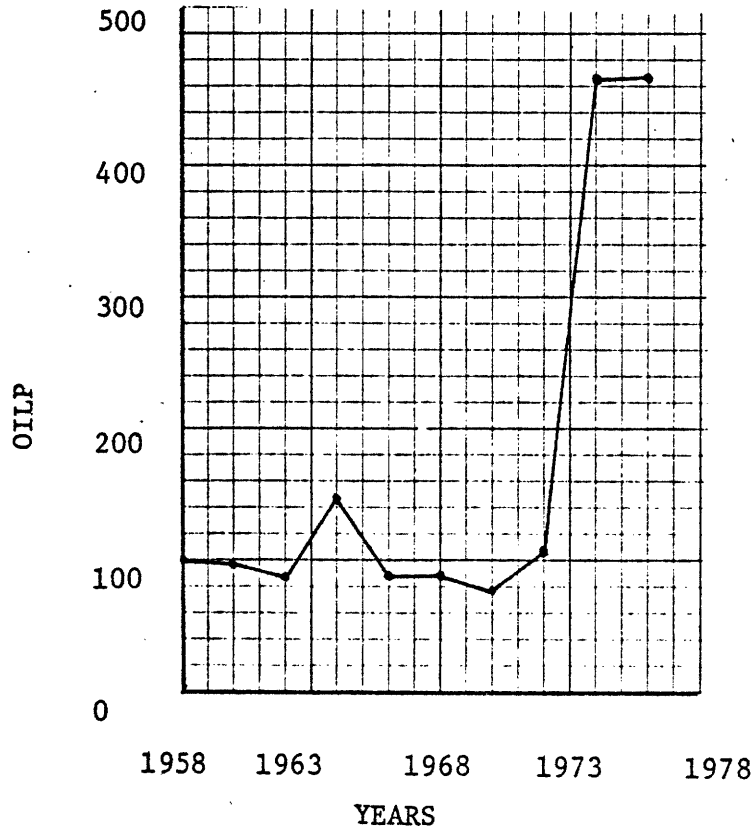

Figure A.39: Oil Price Versus Time.

```

OILP.K=TABHL(TOILP,TIME.K,1958,1976,2)*(1+          241, A
  STEP(STOP,TSTOP))+CLIP(0,TGIPO,1980,TIME.K)(465)
  (EXP(RGPO*(TIME.K-1980))-1)
STOP=0          241.2, C
TSTOP=1985     241.3, C
RGPO=.05       241.4, C
TGIPO=0        241.5, C
TOILP=101/95.0/88.0/129.4/86.77/85.46/79.42/107.99/ 241.6, T
  462.8/465
OILP - OIL PRICE (RIALS/BARRELS)
TOILP - TABLE FOR OIL PRICE
STEP - STEP FUNCTION
STOP - STEP RISE IN OIL PRICE (DIMENSIONLESS)
TSTOP - TIME FOR STEP RISE IN OIL PRICE (YEARS)
CLIP - CLIP FUNCTION
TGIPO - TEST FOR GRADUAL INCREASE IN PRICE OF OIL
        (DIMENSIONLESS)
EXP - EXPONENTIAL FUNCTION
RGPO - RATE OF GROWTH OF PRICE OF OIL(PERCENTAGE
        PER YEAR)

```

to oil exports for different years. The deflator of imported goods at 1972 prices from SRU Table 110 and different issues of BMAR is used to obtain the real price of oil in terms of 1972 prices. The ratio of government's income from oil to oil exports rose sharply in 1964 and fell after that year because in 1964 Iran received 185 million dollars in bonuses from new oil companies.

Oil price, in Equation 241, is equal to actual oil revenues per barrel of oil from 1959 through 1976. After 1976, oil price can be (1) kept constant at the 1976 price level, (2) increased by a step function in a year determined by time for step rise in price of oil TSTOP, or (3) increased exponentially after 1980 by a rate of growth of price of oil RGPO. TSTOP, in Equation 245.3, is set at 1985. Step high is set by the value of step rise in oil price STOP, Equation 245.1. STOP in the standard run is zero but can be changed to examine the effect of a sharp rise in oil price on the economy. The rate of growth of the price of oil RGPO is set at 5 percent per year in Equation 245.3. Exponential growth of oil price will become effective in the model only when the test for a gradual increase in the price of oil TGIPO, Equation 245.4, is changed from zero to one.

A.8 POPULATION SECTOR

Population POP, Equation 243, is the sum of adult population AP, school-age children SAC, and pre-school age children PSC.

$$\text{POP.K} = \text{AP.K} + \text{SAC.K} + \text{PSC.K} \quad 243, \text{ A}$$

POP - POPULATION (PERSONS)  
AP - ADULT POPULATION (PERSONS)  
SAC - SCHOOL AGE CHILDREN (PERSONS)  
PSC - PRE-SCHOOL AGE CHILDREN (PERSONS)

Adult population AP, Equation 244, is increased by the flow of school-age children to adult population SAA and decreased by the death rate of adult population DRAP. The initial value of adult population APN is set at 11,999,000 persons which was the number of person over 15 years old in 1959.<sup>1</sup>

$$\text{AP.K} = \text{AP.J} + \text{DT} * (\text{SAA.JK} - \text{DRAP.JK}) \quad 244, \text{ L}$$
$$\text{AP} = \text{APN} \quad 244.1, \text{ N}$$
$$\text{APN} = 11999000 \quad 244.2, \text{ C}$$

AP - ADULT POPULATION (PERSONS)  
SAA - FLOW OF SCHOOL-AGE TO ADULT POPULATION (PERSONS/YEAR)  
DRAP - DEATH RATE OF ADULT POPULATION (PERSONS/YEAR)  
APN - ADULT POPULATION INITIAL (PERSONS)

School-age children SAC, Equation 245, is increased by the flow of pre-school age children to school-age children PSSA, and is decreased by the flow of school-age children to adult population SAA and the death rate of school-age children DRSAC. The initial value of school-age children SACN is set at 3,959,000 which was the size of the 7-14 years

old population in 1959 as derived from data in Iran Statistical Yearbook 1350 (Farsi Version p. 35).

SAC.K=SAC.J+DT*(PSSA.JK-SAA.JK-DRSAC.JK)	245, L
SAC=SACN	245.1, N
SACN=3957000	245.2, C
SAC - SCHOOL AGE CHILDREN (PERSONS)	
PSSA - FLOW OF PRE-SCHOOL TO SCHOOL-AGE CHILDREN (PERSONS/YEAR)	
SAA - FLOW OF SCHOOL-AGE TO ADULT POPULATION (PERSONS/YEAR)	
DRSAC - DEATH RATE OF SCHOOL-AGE CHILDREN (PERSONS/YEAR)	
SACN - SCHOOL AGE CHILDREN INITIAL (PERSONS)	

Pre-school age children PSC, Equation 246, is increased by birth rate BR and is decreased by the flow of pre-school age to school-age children PSSA and death rate of pre-school age children DRPSC. The initial value of pre-school age children is set at 5,221,000, derived from data in Iran Statistical Yearbook 1350 (Farsi version, p.30).

PSC.K=PSC.J+DT*(BR.JK-PSSA.JK-DRPSC.JK)	246, L
PSC=PSCN	246.1, N
PSCN=5221000	246.2, C
PSC - PRE-SCHOOL AGE CHILDREN (PERSONS)	
BR - BIRTH RATE (PERSONS/YEAR)	
PSSA - FLOW OF PRE-SCHOOL TO SCHOOL-AGE CHILDREN (PERSONS/YEAR)	
DRPSC - DEATH RATE OF PRE-SCHOOL-AGE CHILDREN (PERSONS/YEAR)	
PSCN - PRE-SCHOOL AGE CHILDREN INITIAL (PERSONS)	

Birth rate BR, Equation 247, is equal to adult population AP times normal birth rate NBR times multiplier for birth rate from food MBRF time multiplier for birth rate from industrialization MBRI and times multiplier for birth rate from education MBRE. The values of three multipliers MBRF, MBRI, and MBRE, under 1974 conditions, will be set at one. Therefore, under 1974 conditions, BR will become adult population AP times the normal birth rate NBR. NBR, which is birth rate per adult population in 1974, is set at 0.10. The Statistical Center of Plan and Budget Organization estimated that in 1974, the fertility of married women was 2.45 births per 1000 women.<sup>2</sup> If we assume that about 20% of the adult population are not married, and that 50% of the adult population is male, then birth rate per adult population in 1974 would be:

$$\frac{245}{2} \times \frac{1}{1.2} = 0.1$$

BR.KL=AP.K\*NBR\*MBRF.K\*MBRI.K\*MBRE.K  
NBR=0.10

247, R  
247.1, C

BR - BIRTH RATE (PERSONS/YEAR)  
AP - ADULT POPULATION (PERSONS)  
NBR - NORMAL BIRTH RATE (PERSONS/YEAR/PERSON)  
MBRF - MULTIPLIER FOR BIRTH RATE FROM FOOD  
(DIMENSIONLESS)  
MBRI - MULTIPLIER FOR BIRTH RATE FROM  
INDUSTRIALIZATION (DIMENSIONLESS)  
MBRE - MULTIPLIER FOR BIRTH RATE FROM EDUCATION  
(DIMENSIONLESS)

The multiplier for birth rate from food MBRF, Equation 248, is a function of the ratio of food per capita FPC to normal food per capita NFPC. NFPC represents food per capita in 1974, which was 8,582 rials per person per year at 1972 constant prices.<sup>3</sup> Figure A.40 shows the relationship between MBRF and FPC/NFPC. When food per capita is zero, life becomes impossible and, naturally, birth will be zero as indicated by the zero value of MBRF. When food per capita is normal - i.e., (FPC/NFPC) is one - the effect of food on birth rate is neutral by the definition of normal birth rate, and MBRF is set at one. As FPC increases, so does MBRF, with a diminishing rate. At the extreme, when food per capita becomes 2.5 times its normal value, MBRF levels off at 1.25.

Food per capita FPC, Equation 249, is equal to total food divided by population.

$$FPC.K = TF.K / (POP.K / 1000000) \quad 249, A$$

FPC	- FOOD PER CAPITA (RIALS/YEAR/PERSON)
TF	- TOTAL FOOD (1E6 RIALS/YEAR)
POP	- POPULATION (PERSONS)

The multiplier for birth rate from education MBRE, Equation 250, is a function of the ratio of school years per adult population SYPAP to normal school year per adult population NSYPAP. NSYPAP is school year

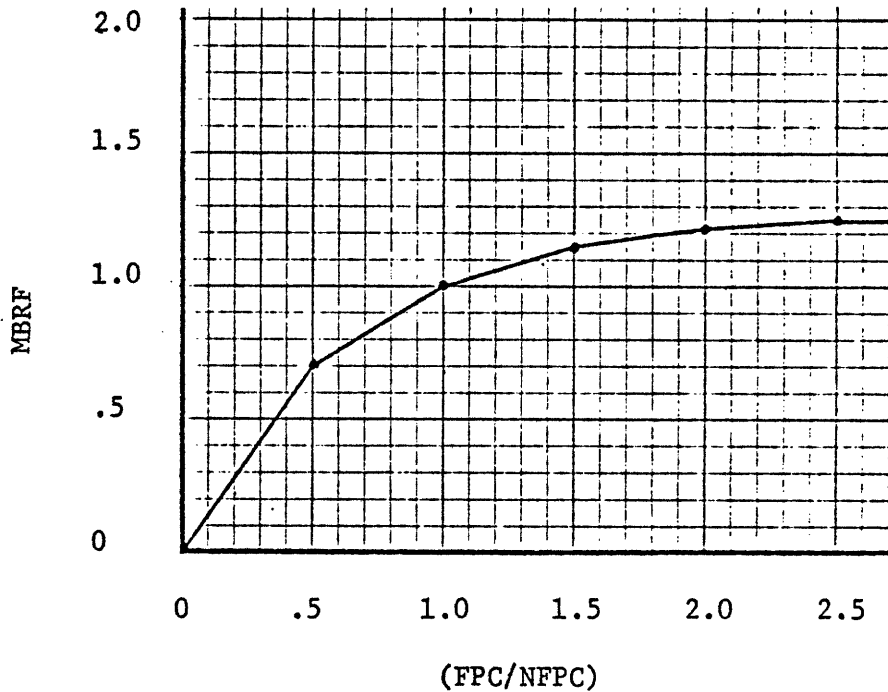

Figure A.40: The Multiplier for Birth Rate from Food Versus the Ratio of Food Output Per Capita to Normal Food Output Per Capita.

```
MBRF.K=TABHL(TMBRF,(FPC.K/NFPC),0,2.5,.5)           248, A
TMBRF=0/.7/1/1.15/1.22/1.25                         248.1, T
NFPC=8582                                             248.2, C
  MBRF - MULTIPLIER FOR BIRTH RATE FROM FOOD
          (DIMENSIONLESS)
  TMBRF - TABLE FOR MULTIPLIER FOR BIRTH RATE FROM
          FOOD
  FPC   - FOOD PER CAPITA (RIALS/YEAR/PERSON)
  NFPC  - NORMAL FOOD PER CAPITA (RIALS/YEAR/PERSON)
```

per adult population in 1974. Figure A.41 shows the functional relationship between MBRE and (SYPAP/NSYPAP). When the education level of the population is zero, the birth rate is assumed to be 1.3 times the normal birth rate and MBRE is set at 1.3. When SYPAP is at its normal value and (SYPAP/NSYPAP) is one, MBRE is set at one. As school-year per adult population increases, MBRE falls. At the extreme, when SYPAP becomes 5 times its normal value, MBRE levels off at 0.65.

The normal school year per adult population NSYPAP is derived by dividing total education level in 1974 to adult population in 1974. From Table A.6, total education level in 1974 was 21,452 thousands man-years of schooling. the population in 1974 was 32,496,000, according to SRU March 1976, Table 76. The ratio of adult population (15 years and older) to total population is estimated to be 0.545 in 1974 by the Statistical Center of Plan and Budget Organization in "The Measurement of Population Growth in Iran," (in Farsi, 1976, p. 30). Therefore, school year per adult population in 1974 would be:

$$\text{NSYPAP} = \frac{21452000}{3249600 \times 0.545} = 1.21 \text{ years of schooling per person}$$

The multiplier for birth rate from industrialization MBRI, Equation 251, is a function of the ratio of industrial output per capita IPC to the normal industrial output per capita NIPC. NIPC is industrial output per capita in 1974, which was 33,75 rials per person per year.<sup>4</sup>



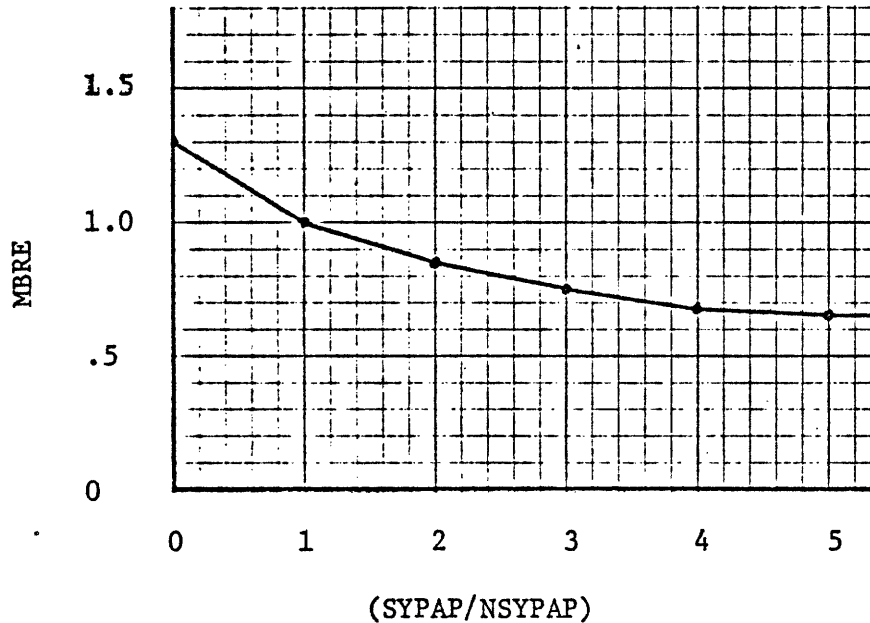

Figure A.41: The Multiplier for Birth Rate from Education Versus the Ratio of School Year per Adult Population Over Normal School Years per Adult Population.

```
MBRE.K=TABHL(TMBRE, (SYPAP.K/NSYPAP), 0, 5, 1)           250, A
TMBRE=1.3/1/.85/.75/.68/.65                             250.1, T
NSYPAP=1.21                                              250.2, C
  MBRE      - MULTIPLIER FOR BIRTH RATE FROM EDUCATION
              (DIMENSIONLESS)
  SYPAP     - SCHOOL-YEARS PER ADULT POPULATION (MAN-
              YEARS OF SCHOOLING/PERSON)
  NSYPAP    - NORMAL SCHOOL YEAR PER ADULT POPULATION
              (YEARS-OF-SCHOOLING/PERSON)
```

Figure A.42 shows the relationship between MBRI and (IPC/NIPC). When IPC is zero, birth rate is assumed to be 40% more than its normal value and MBRI is set at 1.4. When IPC has its normal value and IPC/NIPC becomes 1, MBRI is one. As IPC increases, MBRI drops with a diminishing rate. At the extreme, when IPC becomes 5 times its normal value, MBRI levels off at 0.5.

Industrial output per capita IPC, Equation 252, is equal to the industrial output IOUT divided by population POP.

$$\begin{aligned} \text{IPC.K} &= \text{IOUT.K} / (\text{POP.K} / 1000000) && 252, \text{ A} \\ \text{NIPC} &= 33758 && 252.1, \text{ C} \\ \text{IPC} & - \text{INDUSTRIAL OUTPUT PER CAPITA (RIALS/YEAR/} \\ & \quad \text{PERSON)} \\ \text{IOUT} & - \text{INDUSTRIAL OUTPUT (1E6 RIALS/YEAR)} \\ \text{POP} & - \text{POPULATION (PERSONS)} \\ \text{NIPC} & - \text{NORMAL INDUSTRIAL OUTPUT PER CAPITA (RIALS/} \\ & \quad \text{YEAR/PERSON)} \end{aligned}$$

Death rate of pre-school age children DRPSC, Equation 253, is equal to the normal death rate for pre-school age children NDRPS times pre-school age children population PSC times the multiplier for death rate from food MDRF times the multiplier for death rate from industrialization MDRI. The values of two multipliers, MDRF and MDRI,

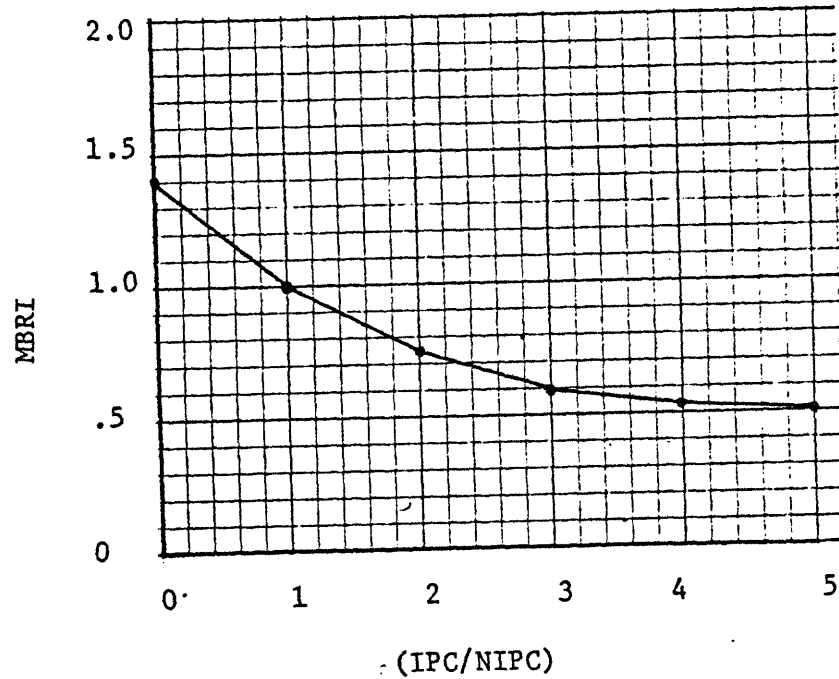

Figure A.42: The Multiplier for Birth Rate from Industrialization Versus the Ratio of Industrial Output Per Capita to the Normal Industrial Output Per Capita.

```
MBRI.K=TABHL(TMBRI,(IPC.K/NIPC),0,5,1)           251, A
TMBRI=1.4/1/.75/.6/.54/.5                         251.1, T
  MBRI    - MULTIPLIER FOR BIRTH RATE FROM
             INDUSTRIALIZATION (DIMENSIONLESS)
  TMBRI   - TABLE FOR MULTIPLIER FOR BIRTH RATE FROM
             EDUCATION
  IPC     - INDUSTRIAL OUTPUT PER CAPITA (RIALS/YEAR/
             PERSON)
  NIPC    - NORMAL INDUSTRIAL OUTPUT PER CAPITA (RIALS/
             YEAR/PERSON)
```

under 1974 conditions, will be set at one. Therefore, under such conditions, DRPSC becomes equal to NDRPS times PSC.

DRPSC.KL=NDRPS*PSC.K*MDRF.K*MDRI.K	253, R
NDRPS=0.036	253.1, C
DRPSC - DEATH RATE OF PRE-SCHOOL-AGE CHILDREN (PERSONS/YEAR)	
NDRPS - NORMAL DEATH RATE OF PRE-SCHOOL-AGE CHILDREN (PERSONS/YEAR/PERSON)	
PSC - PRE-SCHOOL AGE CHILDREN (PERSONS)	
MDRF - MULTIPLIER FOR DEATH RATE FROM FOOD (DIMENSIONLESS)	
MDRI - MULTIPLIER FOR DEATH RATE FROM INDUSTRIALIZATION (DIMENSIONLESS)	

The normal death rate of pre-school age children NDRPS is the death rate of pre-school age children to the population of pre-school age children in 1974 and equals 36 deaths per thousands per year.<sup>5</sup>

The multiplier for death rate from food MDRF, Equation 254, is a function of the ratio of food per capita FPC to normal food per capita NFPC. Figure A.43 shows the functional relationship between MDRF and (FPC/NFPC). When food per capita is zero, life is impossible and the death rate is catastrophically high. When FPC equals zero, in Figure A.43, MDRF is assumed to be 30. As food per capita increases, MDRF decreases with a diminishing rate. When food per capita is at its 1974

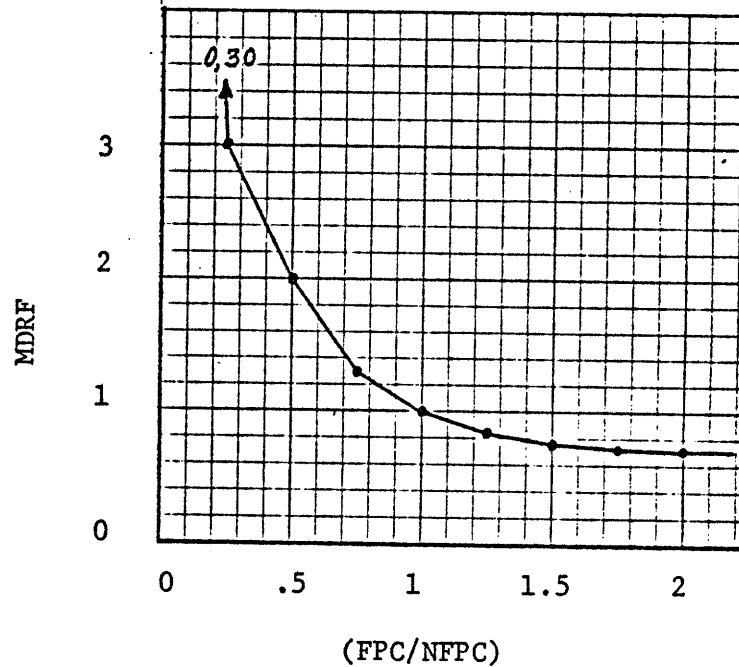

Figure A.43: The Multiplier for Death Rate from Food Versus the Ratio of Food Per Capita to the Normal Food Per Capita.

MDRF.K=TABHL(TMDRF, (FPC.K/NFPC), 0, 2, .25)

254, A

TMDRF=30/3/2/1.3/1/.85/.78/.72/.70

254.1, T

MDRF - MULTIPLIER FOR DEATH RATE FROM FOOD  
(DIMENSIONLESS)

TMDRF - TABLE FOR MULTIPLIER FOR DEATH RATE FROM  
FOOD

FPC - FOOD PER CAPITA (RIALS/YEAR/PERSON)

NFPC - NORMAL FOOD PER CAPITA (RIALS/YEAR/PERSON)

normal value and (FPC/NFPC) is one, MDRF is also one - i.e., the effect of food on the death rate is neutral. At the extreme, when FPC/NFPC becomes 2, MDRF levels off at 0.7.

The multiplier for death rate from industrialization MDRI is a function of the ratio of industrial output per capita IPC to the normal industrial output per capita NIPC. Figure A.44 shows the relationship between MDRI and (IPC/NIPC). When industrial output per capita is zero, MDRI is assumed to be 2. As IPC increases, MDRI decreases with a diminishing rate. When IPC is at its normal value and (IPC/NIPC) is one, MDRI is also one. When (IPC/NIPC) becomes 4, MDRI levels off at 0.65.

Death rate of school-age children DRSAC, Equation 256, is equal to the normal death rate of school-age children NDRSA times school-age children SAC times the multiplier for death rate from industrialization MDRI. The normal death rate of school-age children NDRSA is the death rate of school-age children per population of school-age children in 1974 and equals 2.5 deaths per thousands per year.<sup>6</sup>

DRSAC.KL=NDRSA*SAC.K*MDRF.K*MDRI.K	256, R
NDRSA=0.0025	256.1, C
DRSAC	- DEATH RATE OF SCHOOL-AGE CHILDREN (PERSONS/YEAR)
NDRSA	- NORMAL DEATH RATE OF SCHOOL-AGE CHILDREN (PERSONS/YEAR /PERSON)
SAC	- SCHOOL AGE CHILDREN (PERSONS)
MDRF	- MULTIPLIER FOR DEATH RATE FROM FOOD (DIMENSIONLESS)
MDRI	- MULTIPLIER FOR DEATH RATE FROM INDUSTRIALIZATION (DIMENSIONLESS)

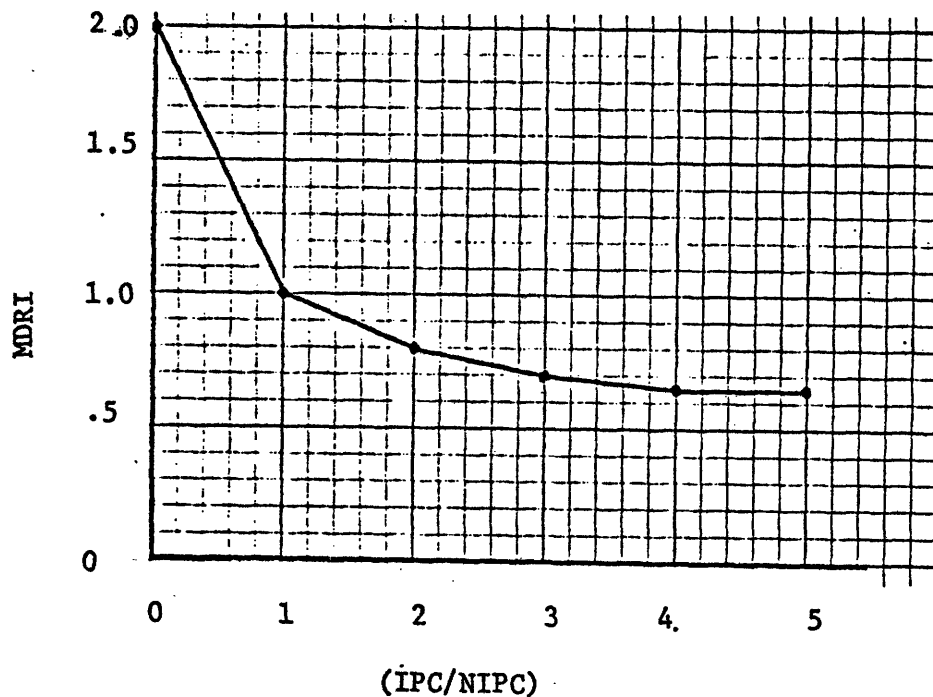

Figure A.44: The Multiplier for Death Rate from Industrialization Versus the Ratio of Industrial Output Per Capita to the Normal Industrial Output Per Capita.

```

MDRI.K=TABHL(TMDRI,(IPC.K/NIPC),0,5,1)           255, A
TMDRI=2/1/.8/.7/.65/.65                          255.1, T
MDRI      - MULTIPLIER FOR DEATH RATE FROM
            INDUSTRIALIZATION (DIMENSIONLESS)
TMDRI     - TABLE FOR MULTIPLIER FOR DEATH RATE FROM
            INDUSTRIALIZATION
IPC       - INDUSTRIAL OUTPUT PER CAPITA (RIALS/YEAR/
            PERSON)
NIPC     - NORMAL INDUSTRIAL OUTPUT PER CAPITA (RIALS/
            YEAR/PERSON)
    
```

The death rate of adult population DRAP, Equation 257, is equal to adult population AP times the normal death rate of adult population NDRAP times the multiplier for death rate from food MDRF times the multiplier for death rate from industrialization MDRI. NDRAP is the death rate of adult population per adult population under 1974 conditions. NDRAP is set at 0.0195, which results in a population growth rate of 3 percent, equivalent to the actual growth rate of the population in 1974.

DRAP.KL=AP.K\*NDRA\*MDRF.K\*MDRI.K 257, R  
NDRA=.0141 257.1, C  
DRAP - DEATH RATE OF ADULT POPULATION (PERSONS/  
YEAR)  
AP - ADULT POPULATION (PERSONS)  
NDRA - NORMAL DEATH RATE OF ADULT POPULATION  
(PERSONS/YEAR/PERSON)  
MDRF - MULTIPLIER FOR DEATH RATE FROM FOOD  
(DIMENSIONLESS)  
MDRI - MULTIPLIER FOR DEATH RATE FROM  
INDUSTRIALIZATION (DIMENSIONLESS)

The flow of pre-school age children to school-age children PSSA, Equation 258, is equal to pre-school age children PSC divided by the duration of the pre-school period DPSP. DPSP is equal to 6 years.

PSSA.KL=PSC.K/DPSP 258, R  
DPSP=6 258.1, C  
PSSA - FLOW OF PRE-SCHOOL TO SCHOOL-AGE CHILDREN  
(PERSONS/YEAR)  
PSC - PRE-SCHOOL AGE CHILDREN (PERSONS)  
DPSP - DURATION OF PRE-SCHOOL PERIOD (YEARS)



The flow of school-age children to the adult population SAA, Equation 259, is equal to school-age children SAC divided by the duration of the school-age period DSAP.

$$\text{SAA.KL} = \text{SAC.K} / \text{DSAP.K} \quad 259, R$$

SAA - FLOW OF SCHOOL-AGE TO ADULT POPULATION (PERSONS/YEAR)  
SAC - SCHOOL AGE CHILDREN (PERSONS)  
DSAP - DURATION OF SCHOOL-AGE PERIOD (YEARS)

The duration of the school-age period DSAP, Equation 260, is 8 years plus a fraction of the difference between the potential duration of the school-age period PDSAP and 8 years. The fraction is the ratio of the number of students NST to school-age children SAC. If all school-age children are at school and NST equals SAC, then DSAP becomes equal to PDSAP. Otherwise, the value of PSAP would be between 8 years and PDSAP depending on the ratio of NST to SAC.

$$\text{DSAP.K} = 8 + (\text{PDSAP.K} - 8) * (\text{NST.K} / \text{SAC.K}) \quad 260, A$$

DSAP - DURATION OF SCHOOL-AGE PERIOD (YEARS)  
PDSAP - POTENTIAL DURATION OF SCHOOL-AGE PERIOD (YEARS)  
NST - NUMBER OF STUDENTS (PERSONS)  
SAC - SCHOOL AGE CHILDREN (PERSONS)

The potential duration of the school-age period PDSAP, Equation 261, is a function of duration of education DE. Figure A.45 shows the relationship between PDSAP and DE. When DE is less than 8 years, PDSAP

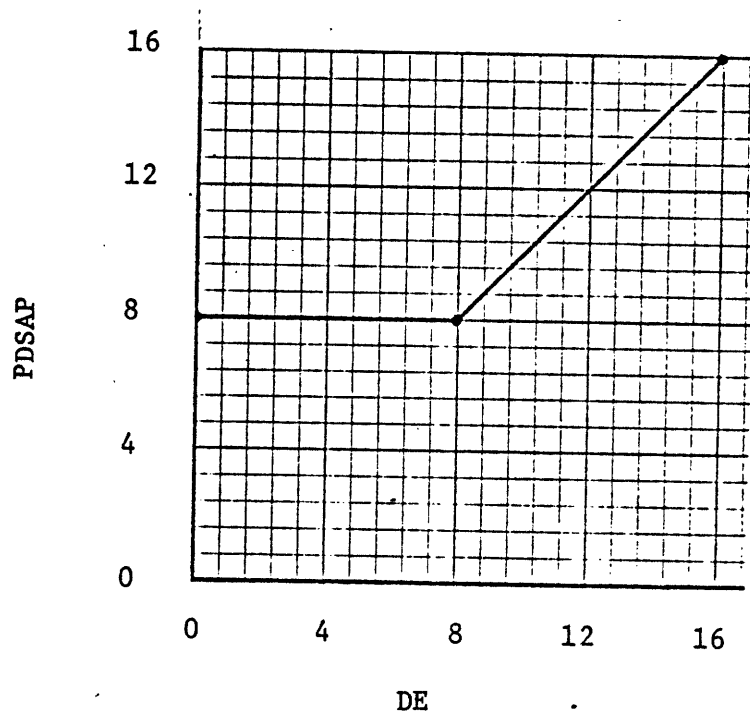

Figure A.45: Potential Duration of the School-Age Period Versus Duration of Education.

PDSAP.K=TABLE(TPDSAP,DE.K,0,16,8)

261, A

TPDSAP=8/8/16

261.1, T

PDSAP - POTENTIAL DURATION OF SCHOOL-AGE PERIOD  
(YEARS)

TPDSAP - TABLE FOR POTENTIAL PERIOD OF SCHOOL-AGE  
PERIOD

DE - DURATION OF EDUCATION (YEARS)

is 8 years. As DE increases above 8 years, PDSAP also rises above 8 years and remains equal to DE.

Labor L, Equation 262, is a fraction of adult population AP. The fraction is the ratio of labor to adult population RLAP. RLAP is assumed constant at 0.56, which has been the ratio of labor to average adult population from 1959 through 1974.

$$\begin{array}{ll} L.K=AP.K*RLAP & 262, A \\ RLAP=.56 & 262.1, C \\ L & - \text{LABOR FORCE (PERSONS)} \\ AP & - \text{ADULT POPULATION (PERSONS)} \\ RLAP & - \text{RATIO OF LABOR FORCE TO ADULT POPULATION} \\ & \text{(DIMENSIONLESS)} \end{array}$$

In the population sector, crude birth rate and crude death rates for different age categories are also calculated. Crude birth rate CBR, Equation 263, is birth rate BR divided by adult population AP.

$$\begin{array}{ll} CBR.K=(BR.JK/AP.K)*1000 & 263, S \\ CBR & - \text{CRUDE BIRTH RATE (1/YEAR)} \\ BR & - \text{BIRTH RATE (PERSONS/YEAR)} \\ AP & - \text{ADULT POPULATION (PERSONS)} \end{array}$$

Crude death rate of adult population CDRAP, Equation 264, is equal to the ratio of the death rate of the adult population DRAP to adult population AP.

CDRAP.K=(DRAP.JK/AP.K)\*1000 264, S  
CDRAP - CRUDE DEATH RATE FOR ADULT POPULATION (1/  
YEAR)  
DRAP - DEATH RATE OF ADULT POPULATION (PERSONS/  
YEAR)  
AP - ADULT POPULATION (PERSONS)

Crude death rate of school-age children CRRSAC, Equation 265, is the ratio of the death rate of school-age children DRSAC to the population of school-age children SAC.

CDRSAC.K=(DRSAC.JK/SAC.K)\*1000 265, S  
CDRSAC - CRUDE DEATH RATE FOR SCHOOL-AGE CHILDREN  
(1/YEAR)  
DRSAC - DEATH RATE OF SCHOOL-AGE CHILDREN  
(PERSONS/YEAR)  
SAC - SCHOOL AGE CHILDREN (PERSONS)

Crude death rate of pre-school age children CDRPSA is the ratio of the death rate of pre-school age children DRPSC to pre-school age children PSC.

CDRPSA.K=(DRPSC.JK/PSC.K)\*1000 266, S  
CDRPSA - CRUDE DEATH RATE FOR PRE-SCHOOL AGE  
CHILDREN (1/YEAR)  
DRPSC - DEATH RATE OF PRE-SCHOOL-AGE CHILDREN  
(PERSONS/YEAR)  
PSC - PRE-SCHOOL AGE CHILDREN (PERSONS)

Crude death rate of total population CDRTTP is the ratio of death rate of total population DR to population POP.

$CDRTP.K = (DR.K / POP.K) * 1000$  267, S  
CDRTP - CRUDE DEATH RATE FOR TOTAL POPULATION (1/  
YEAR)  
DR - DEATH RATE (PERSONS/YEAR)  
POP - POPULATION (PERSONS)

The death rate of total population DR is the sum of the death rate of pre-school age children DRPSC, the death rate of school-age children DRSAC, and the death rate of adult population DRAP.

$DR.K = DRPSC.JK + DRSAC.JK + DRAP.JK$  268, A  
DR - DEATH RATE (PERSONS/YEAR)  
DRPSC - DEATH RATE OF PRE-SCHOOL-AGE CHILDREN  
(PERSONS/YEAR)  
DRSAC - DEATH RATE OF SCHOOL-AGE CHILDREN  
(PERSONS/YEAR)  
DRAP - DEATH RATE OF ADULT POPULATION (PERSONS/  
YEAR)

#### A.9 THE EDUCATION SECTOR

Education E, Equation 270, is increased by the rate of increase of education RIE and decreased by the rate of reduction of education RE. The initial value of education EN is set at 10,000 thousands man-years of schooling, which was the education level of the country as shown in Table A.6.

$E.K = E.J + DT * (RIE.JK - RE.JK)$  270, L  
 $E = EN$  270.1, N  
 $EN = 10000$  270.2, C

E - EDUCATION (1000 MAN-YEARS OF SCHOOLING)  
RIE - RATE OF INCREASE OF EDUCATION (1000 MAN-YEARS OF SCHOOLING/YEAR)  
RE - REDUCTION OF EDUCATION (1000 MAN-YEARS OF SCHOOLING/YEAR)  
EN - EDUCATION INITIAL (1000 MAN-YEARS OF SCHOOLING)

The rate of reduction of education RE, Equation 271, is equal to education E times the normal death rate of adult population NDRA times the multiplier for death rate from food MDRF times the multiplier for death rate from industrialization MDRI.

$RE.KL = E.K * NDRA * MDRF.K * MDRI.K$  271, R

RE - REDUCTION OF EDUCATION (1000 MAN-YEARS OF SCHOOLING/YEAR)  
E - EDUCATION (1000 MAN-YEARS OF SCHOOLING)  
NDRA - NORMAL DEATH RATE OF ADULT POPULATION (PERSONS/YEAR/PERSON)  
MDRF - MULTIPLIER FOR DEATH RATE FROM FOOD (DIMENSIONLESS)  
MDRI - MULTIPLIER FOR DEATH RATE FROM INDUSTRIALIZATION (DIMENSIONLESS)

The rate of increase of education RIE, Equation 272, is equal to the termination rate TR times the duration of education DE times one minus the drop-out ratio DROP.

$RIE.KL = (TR.JK * DE.K * (1 - DROP.K)) / 1000$  272, R  
RIE - RATE OF INCREASE OF EDUCATION (1000 MAN-  
YEARS OF SCHOOLING/YEAR)  
TR - TERMINATION RATE (PERSONS/YEAR)  
DE - DURATION OF EDUCATION (YEARS)  
DROP - DROP-OUT RATIO (DIMENSIONLESS)

The drop-out ratio DROP, Equation 273, is a weighted average of drop-out from education DROPE and drop-out from income DROPI. The weighting factor is the coefficient for drop-out from education CDRE. CDRE is assumed to be 0.5 - i.e, the drop-out ratio from education and income are weighted equally in the formulation of DROP.

$DROP.K = CDRE * DROPE.K + (1 - CDRE) * DROPI.K$  273, A  
CDRE = .5 273.1, C  
DROP - DROP-OUT RATIO (DIMENSIONLESS)  
CDRE - COEFFICIENT FOR DROP-OUT FROM EDUCATION  
(DIMENSIONLESS)  
DROPE - DROP-OUT FROM EDUCATION (DIMENSIONLESS)  
DROPI - DROP-OUT FROM INCOME (DIMENSIONLESS)

Drop-out from education DROPE, Equation 274, is a function of school-years per adult population SYPAP. Figure A.46 shows the functional relationship between DROPE and SYPAP. When SYPAP is zero, DROPE is assumed to be 0.60; 60% of those who terminate their education drop out. As SYPAP increases, DROPE decreases with a diminishing rate. Finally, when SYPAP becomes 10, DROPE levels off at 0.1.

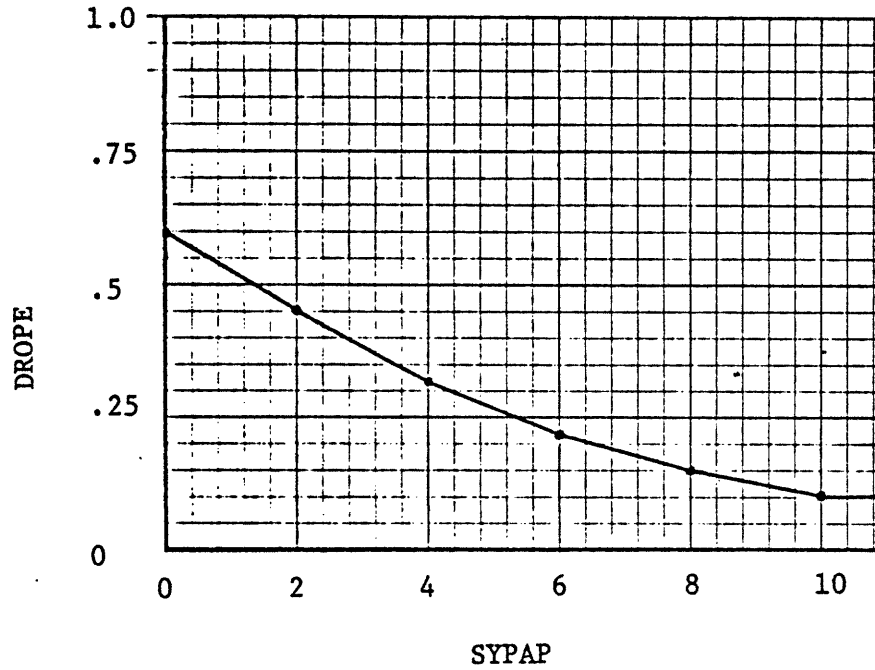

Figure A.46: The Drop-Out from Education Versus School-Years per Adult Population.

```
DROPE.K=TABHL(TDROPE,SYPAP.K,0,10,2)                274, A
TDROPE=.6/.45/.32/.22/.15/.1                       274.1, T
DROPE - DROP-OUT FROM EDUCATION (DIMENSIONLESS)
TDROPE - TABLE FOR DROP-OUT FROM EDUCATION
SYPAP  - SCHOOL-YEARS PER ADULT POPULATION (MAN-
        YEARS OF SCHOOLING/PERSON)
```



School-years per adult population SYPAP, Equation 275, is the

$$\text{SYPAP.K} = (\text{E.K} * 1000) / \text{AP.K} \quad 275, \text{ A}$$

SYPAP - SCHOOL-YEARS PER ADULT POPULATION (MAN-YEARS OF SCHOOLING/PERSON)  
E - EDUCATION (1000 MAN-YEARS OF SCHOOLING)  
AP - ADULT POPULATION (PERSONS)

Drop-out from income DROPI, Equation 276, is a function of GNP per capita GNPPC. Figure A.47 shows the relationship between DROPI and GNPPC. When GNPPC is at a subsistence level, people are not concerned about education and drop-out is high. In Figure A.54, when GNPPC is zero, DROPI is assumed to be 0.7. As GNPPC increases, DROPI decreases with a diminishing rate. When GNPPC becomes 150,000 rials per year per person, DROPI levels off at 0.1.

The duration of education DE, Equation 277, is a weighted average of duration of education from education DEE and duration of education from income DEDI. The weighting factor is the coefficient for duration of education from education CDEE. CDEE is assumed to be 0.5 - i.e., the duration of education from education and income are weighted equally in the formulation of DE.

$$\text{DE.K} = \text{CDEE} * \text{DEE.K} + (1 - \text{CDEE}) * \text{DEDI.K} \quad 277, \text{ A}$$

CDEE = .5 277.1, C

DE - DURATION OF EDUCATION (YEARS)  
CDEE - COEFFICIENT FOR DURATION OF EDUCATION FROM EDUCATION (DIMENSIONLESS)  
DEE - DURATION OF EDUCATION FROM EDUCATION (YEARS)  
DEDI - DURATION OF EDUCATION FROM INCOME (YEARS)

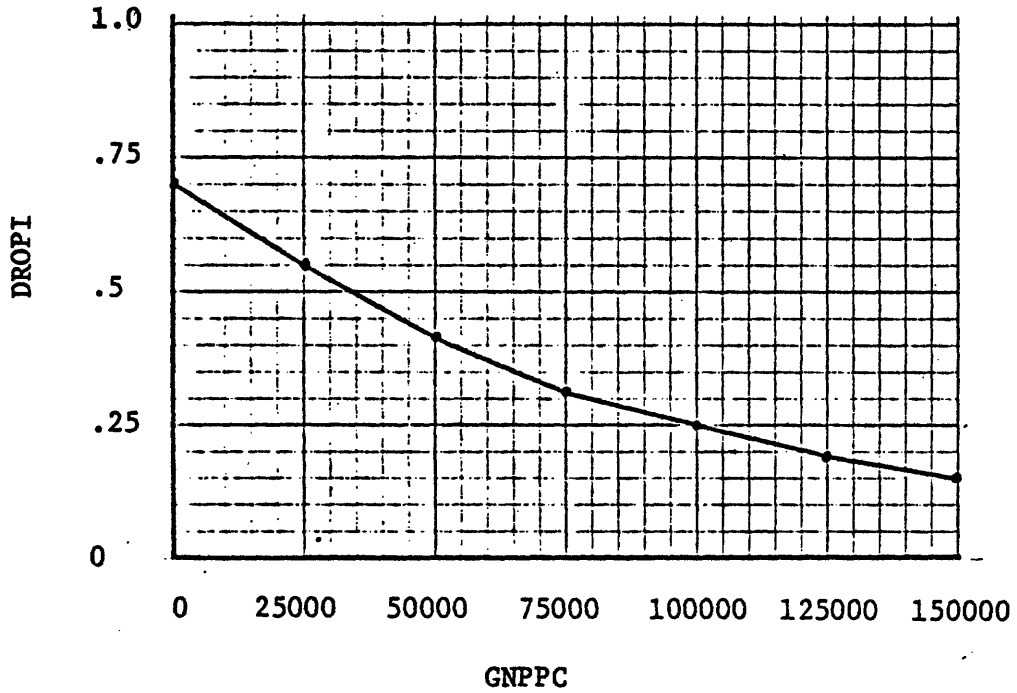

Figure A.47: Drop-Out from Income Versus Gross National Product Per Capita.

```
DROPI.K=TABHL(TDROPI,GNPPC.K,0,150000,25000)           276, A
TDROPI=.7/.55/.42/.32/.25/.19/.15                     276.1, T
DROPI - DROP-OUT FROM INCOME (DIMENSIONLESS)
TDROPI - TABLE FOR DROP-OUT FROM INCOME
GNPPC - GROSS NATIONAL PRODUCT PER CAPITA (RIALS/
        YEAR/PERSON)
```

The duration of education from education DEE, Equation 278, is a function of school-years per adult population SYPAP. Figure A.48 shows the relationship between DEE and SYPAP. When there is no educated person in the population and SYPAP is zero, DEE is assumed to be zero. As people become more educated and SYPAP increases, DEE rises with a diminishing rate. When SYPAP becomes 10 years per person, DEE levels off at 14 years, which is about the average duration of education in advanced countries.

The duration of education from income DEDI, Equation 279, is a function of GNP per capita GNPPC. Figure A.49 shows the relationship between DEDI and GNPPC. When GNPPC is zero, DEDI is assumed to be zero. As GNPPC increases, so does DEDI, with a diminishing rate. When GNPPC becomes 140,000 rials per year, DEDI is assumed to level off at 14 years.

The termination rate TR, Equation 280, is a delayed value of admission rate AR. The length of the delay is duration of education DE. The pipeline stock in the delay is the number of students NST. In order to initialize the embodied stocks in the delay, the admission rate AR is

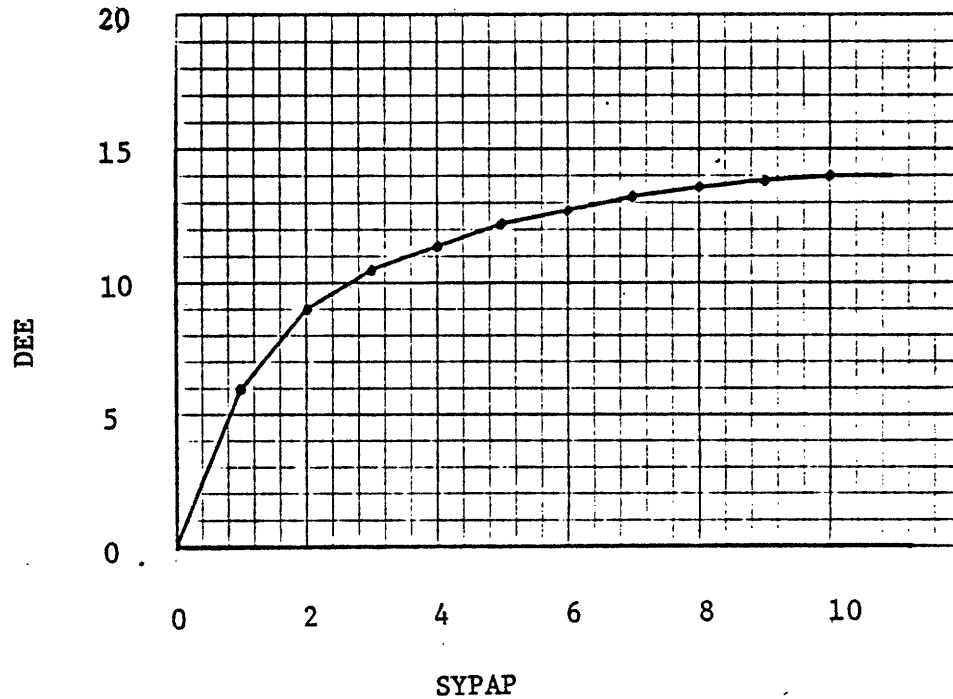

Figure A.48: The Duration of Education from Education Versus School-Years per Adult Population.

```
DEE.K=TABHL(TDEE,SYPAP.K,0,10,1)                278, A
TDEE=0/6/9/10.5/11.4/12.2/12.8/13.3/13.7/13.9/14 278.1, T
DEE      - DURATION OF EDUCATION FROM EDUCATION
           (YEARS)
TDEE     - TABLE FOR DURATION OF EDUCATION FROM
           EDUCATION
SYPAP    - SCHOOL-YEARS PER ADULT POPULATION (MAN-
           YEARS OF SCHOOLING/PERSON)
```

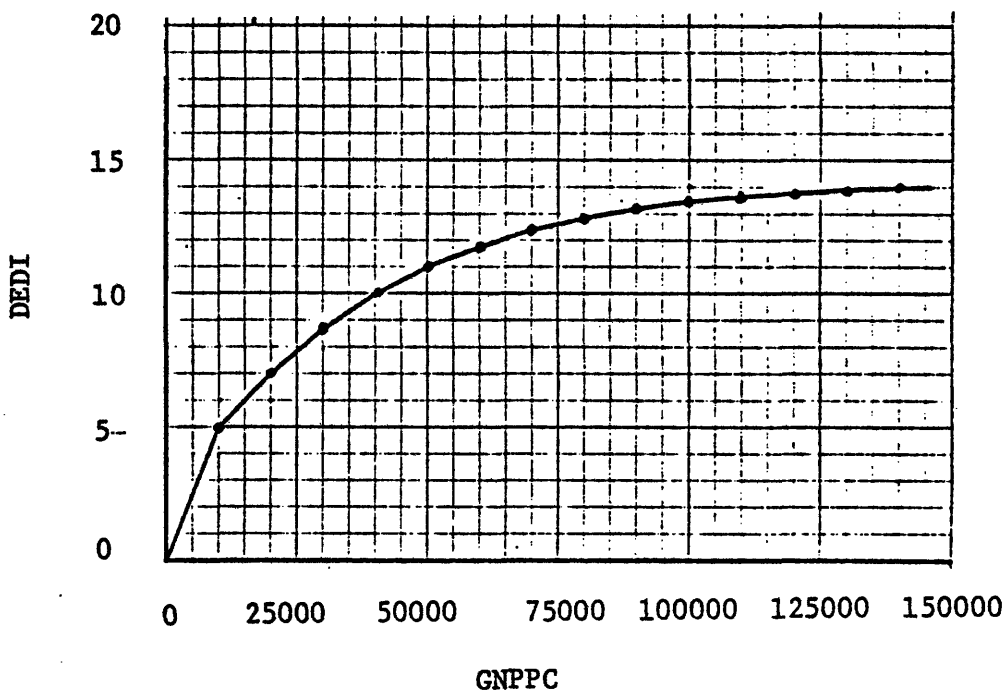

Figure A.49: The Duration of Education from Income Versus Gross National Product Per Capita.

```
DEDI.K=TABHL(TDEI,GNPPC.K,0,140000,10000)          279, A
TDEI=0/5/7/8.8/10/11/11.8/12.4/12.9/13.2/13.5/13.7/ 279.1, T
13.85/13.95/14
DEDI    - DURATION OF EDUCATION FROM INCOME (YEARS)
TDEI    - TABLE FOR DURATION OF EDUCATION FROM INCOME
          (YEARS)
GNPPC   - GROSS NATIONAL PRODUCT PER CAPITA (RIALS/
          YEAR/PERSON)
```

initialized at 270,000 students per year, the number of new students who got admitted to the school system in 1959.<sup>7</sup>

TR.KL=DELAYP (AR.JK,DE.K,NST.K) 280, R  
AR=270000 280.1, N  
TR - TERMINATION RATE (PERSONS/YEAR)  
AR - ADMISSION RATE (PERSONS/YEAR)  
DE - DURATION OF EDUCATION (YEARS)  
NST - NUMBER OF STUDENTS (PERSONS)

The admission rate AR, Equation 281, is equal to the average termination rate ATR plus the difference between enrollment capacity ECAP, adjusted by the effect of social demand on admission rate ESDA, and number of students NST divided by time to adjust number of students TANS. TANS is assumed to be 0.5 year.

AR.KL=((ECAP.K\*ESDA.K-NST.K)/TANS)+ATR.K 281, R  
TANS=.5 281.1, C  
AR - ADMISSION RATE (PERSONS/YEAR)  
ECAP - ENROLLMENT CAPACITY (STUDENTS)  
ESDA - EFFECT OF SOCIAL DEMAND ON ADMISSION RATE  
(DIMENSIONLESS)  
NST - NUMBER OF STUDENTS (PERSONS)  
TANS - TIME TO ADJUST NUMBER OF STUDENTS (YEARS)  
ATR - AVERAGE TERMINATION RATE (PERSONS/YEAR)

Average termination rate ATR, Equation 282, is a smoothed value of termination rate TR. Time to average termination rate TATR is set at one year.

ATR.K=SMOOTH (TR.JK,TATR) 282, A  
TATR=.25 282.1, C  
ATR - AVERAGE TERMINATION RATE (PERSONS/YEAR)  
TR - TERMINATION RATE (PERSONS/YEAR)  
TATR - TIME TO AVERAGE TERMINATION RATE (YEARS)

The effect of social demand on admission rate ESDA, Equation 283, is a function of the ratio of social demand for education SDE to enrollment capacity ECAP. Figure A.50 depicts the relationship between ESDA and (SDE/ECAP). When social demand for education SDE is zero, nobody wants to be admitted into the education system and, therefore, ESDA is set at zero. As (SDE/ECAP) increased above zero, so does ESDA, but with a diminishing rate. When (SDE/ECAP) is equal to one, ESDA becomes 1. When social demand exceeds the enrollment capacity ECAP, ECAP constrains the admission rate and ESDA remains at one. The convex shape of the curve in Figure A.50 implies that when SDE is less than ECAP - i.e., (SDE/ECAP) is less than one - excess enrollment capacity promotes the admission rate above what is implied by social demand for education. In other words, an excess supply of the education facilities is assumed to stimulate demand for education.

Enrollment capacity ECAP, Equation 284, is the ratio of production capacity in education PCE to the production capacity per enrollment capacity PCEC.

$$ECAP.K = (PCE.K * 1000000) / PCEC.K \quad 284, A$$

ECAP - ENROLLMENT CAPACITY (STUDENTS)  
PCE - PRODUCTION CAPACITY IN EDUCATION SECTOR  
(1E6 RIALS/YEAR)  
PCEC - PRODUCTION CAPACITY PER ENROLLMENT CAPACITY  
(1E6 RIALS/YEAR/STUDENT)

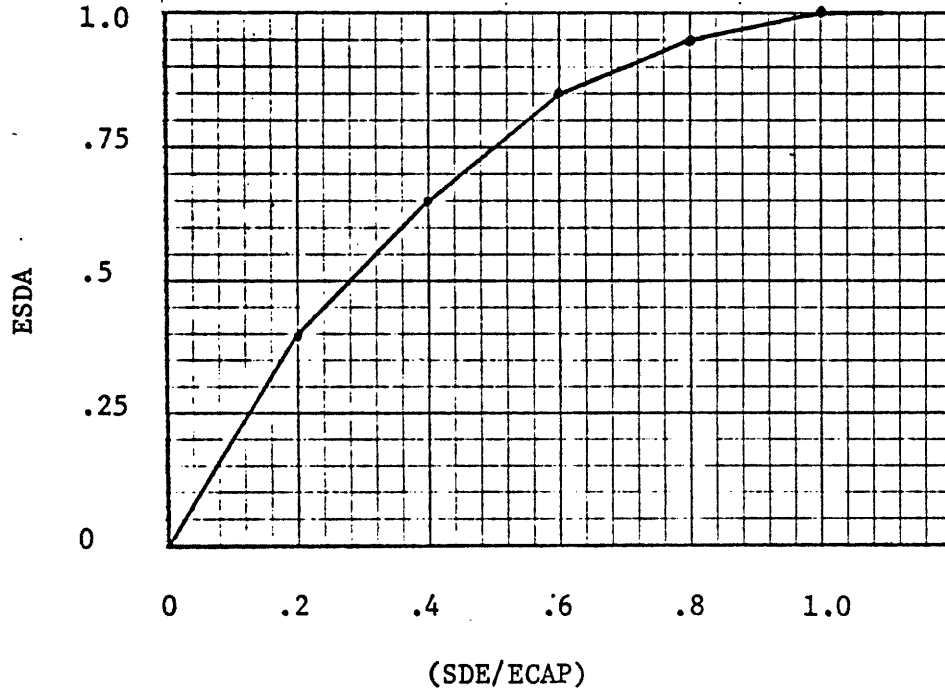

Figure A.50: The Effect of Social Demand on Admssion Rate Versus the Ratio of Social Demand for Education to the Enrollment Capacity.

```
ESDA.K=TABHL(TESDA,(SDE.K/ECAP.K),0,1,.2)           283, A
TESDA=0/.4/.65/.85/.95/1                           283.1, T
ESDA - EFFECT OF SOCIAL DEMAND ON ADMISSION RATE
        (DIMENSIONLESS)
TESDA - TABLE FOR EFFECT OF SOCIAL DEMAND ON
        ADMISSION RATE
SDE - SOCIAL DEMAND FOR EDUCATION (STUDENTS)
ECAP - ENROLLMENT CAPACITY (STUDENTS)
```



Production capacity per enrollment capacity PCEC, Equation 285, is equal to the production capacity per enrollment capacity from duration of education PCECD times the ratio of non-oil output per capita NOOPC to non-oil output per capita normal NOOPCN. NOOPCN, non-oil output per capita in 1974, is 40,891 rials per person at 1972 prices.

$$\begin{aligned} \text{PCEC.K} &= \text{PCECD.K} * (\text{NOOPC.K} / \text{NOOPCN}) && 285, \text{ A} \\ \text{NOOPCN} &= 40891 && 285.1, \text{ C} \end{aligned}$$

PCEC - PRODUCTION CAPACITY PER ENROLLMENT CAPACITY  
(1E6 RIALS/YEAR/STUDENT)

PCECD - PRODUCTION CAPACITY PER ENROLLMENT CAPACITY  
FROM DURATION OF EDUCATION (1E6 RIALS/YEAR  
/STUDENT)

NOOPC - NON-OIL OUTPUT PER CAPITA (1E6 RIALS/YEAR/  
PERSON)

NOOPCN - NON-OIL OUTPUT PER CAPITA NORMAL (RIALS/  
YEAR/PERSON)

The production capacity per enrollment capacity from duration of capacity PCECD, Equation 286, is a function of duration of education DE. Figure A.51 shows the functional relationship between PCECD and DE. In 1974, the average cost per first grade student in Iran is assumed about 9000 rials per year at 1972 prices. Therefore, in Figure A.51, PCECD is set at 9000 as DE approaches zero. As DE increases, the average cost of education per student in the system rises with an accelerating rate. When DE becomes 16, PCECED - i.e., the average cost per student in 1974 educational costs - is assumed to be 1600 rials per year.

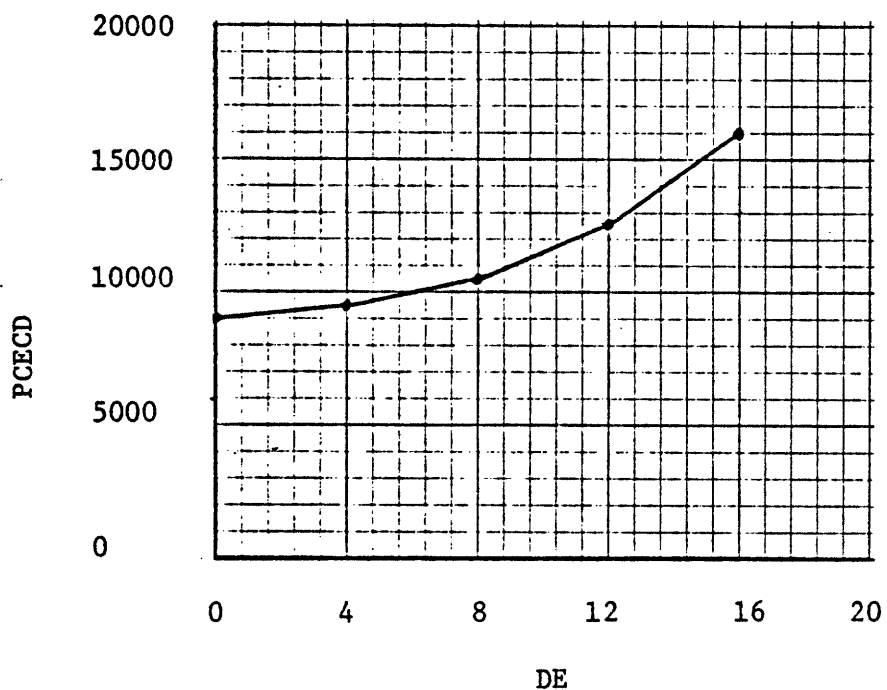

Figure A.51: Production Capacity per Enrollment Capacity from Duration of Education Versus Duration of Education.

```
PCECD.K=TABLE(TPCE,DE.K,0,16,4)                286, A
TPCE=9000/9500/10500/12500/16000             286.1, T
PCECD - PRODUCTION CAPACITY PER ENROLLMENT CAPACITY
        FROM DURATION OF EDUCATION (1E6 RIALS/
        YEAR/STUDENT)
TPCE - TABLE FOR PRODUCTION CAPACITY PER
        ENROLLMENT CAPACITY FROM DURATION OF
        EDUCATION
DE - DURATION OF EDUCATION (YEARS)
```

Non-oil output per capita NOOPC, Equation 287, is non-oil output NOO divided by population POP.

$$\text{NOOPC.K} = (\text{NOO.K} * 1000000) / \text{POP.K} \quad 287, A$$

NOOPC - NON-OIL OUTPUT PER CAPITA (1E6 RIALS/YEAR/PERSON)  
NOO - NON-OIL OUTPUT (1E6 RIALS/YEAR)  
POP - POPULATION (PERSONS)

Production capacity in education sector PCE, Equation 288, is equal to production capacity in industrial sector PCIS times the fraction of production capacity in the education sector FPE.

$$\text{PCE.K} = \text{FPE.K} * \text{PCIS.K} \quad 288, A$$

PCE - PRODUCTION CAPACITY IN EDUCATION SECTOR (1E6 RIALS/YEAR)  
FPE - FRACTION OF PRODUCTION CAPACITY IN EDUCATION (DIMENSIONLESS)  
PCIS - PRODUCTION CAPACITY IN INDUSTRIAL SECTOR (1E6 RIALS/YEAR)

The fraction of production capacity in the education sector FPE, Equation 289, is the average desired production capacity in education sector ADPE divided by the sum of the average desired production capacity in consumption goods, intermediate goods, capital goods, and education sector, ADPCON, ADPI, ADPCAP, and ADPE, respectively.

$$\text{FPE.K} = \text{ADPE.K} / (\text{ADPCON.K} + \text{ADPI.K} + \text{ADPCAP.K} + \text{ADPE.K}) \quad 289, A$$

FPE - FRACTION OF PRODUCTION CAPACITY IN EDUCATION (DIMENSIONLESS)  
ADPE - AVERAGE DESIRED PRODUCTION CAPACITY IN EDUCATION (1E6 RIALS/YEAR)  
ADPCON - AVERAGE DESIRED PRODUCTION CAPACITY IN CONSUMPTION GOODS SECTOR (1E6 RIALS/YEAR)  
ADPI - AVERAGE DESIRED PRODUCTION CAPACITY IN INTERMEDIATE GOODS SECTOR (1E6 RIALS/YEAR)  
ADPCAP - AVERAGE DESIRED PRODUCTION CAPACITY IN CAPITAL GOODS SECTOR (1E6 RIALS/YEAR)

Average desired production capacity in education sector ADPE, Equation 290, is a smooth function of the desired production capacity in education sector DPE. Time to average the desired production capacity in education TADPE is assumed to be 15 years. The initial value of average desired production capacity in education sector ADPEN is set at 12,000 million rials per year.

ADPE.K=SMOOTH(DPE.K,TADPE)	290, A
TADPE=15	290.1, C
ADPE=ADPEN	290.2, N
ADPEN=12000	290.3, C

ADPE - AVERAGE DESIRED PRODUCTION CAPACITY IN EDUCATION (1EL RIALS/YEAR)  
DPE - DESIRED PRODUCTION CAPACITY IN EDUCATION (1E6 RIALS/YEAR)  
TADPE - TIME TO AVERAGE DESIRED PRODUCTION CAPACITY IN EDUCATION (YEARS)  
ADPEN - AVERAGE DESIRED PRODUCTION CAPACITY IN EDUCATION INITIAL (1E6 RIALS/YEAR)

The desired production capacity in the education sector DPE, Equation 291, is equal to the multiplier for production capacity in education from availability MPEA times the production capacity in the education sector PCE.

DPE.K=MPEA.K*PCE.K	291, A
--------------------	--------

DPE - DESIRED PRODUCTION CAPACITY IN EDUCATION (1E6 RIALS/YEAR)  
MPEA - MULTIPLIER FOR PRODUCTION CAPACITY IN EDUCATION FROM AVAILABILITY (DIMENSIONLESS)  
PCE - PRODUCTION CAPACITY IN EDUCATION SECTOR (1E6 RIALS/YEAR)

The multiplier for production capacity in education from availability MPEA, Equation 292, is a function of the availability of enrollment capacity AVEC and test for educational expansion policy TEEP. TEEP will be either one or zero, to test two different policies. When TEEP is one; Curve A in Figure A.52 represents the relationship between MPEA and AVEC. And, when TEEP is zero, Curve B shows the relationship between MPEA and AVEC. When AVEC equals one, MPEA is one on both curves. As AVEC increases, MPEA decreases and vice versa. Curve A reflects an educational expansion policy which is less responsive than the policy represented by Curve B to a shortage of educational facilities. When AVEC decreases below one, MPEA increases more rapidly on Curve B than on Curve A. Curve B is the same as the relationship between the multiplier for production capacity in other industrial sectors and the availability of their outputs, shown on Figure A.17, for the consumption goods sector. Therefore, on Curve B, the expansion of the education sector is as responsive to the availability of education services as the expansion of the other industrial sectors to the availability of their outputs. Curve B indicates that the government's policy to support the education sector is such that the sector is as able as the other production sectors to hire its required production resources. But, Curve A indicates an education policy under which the

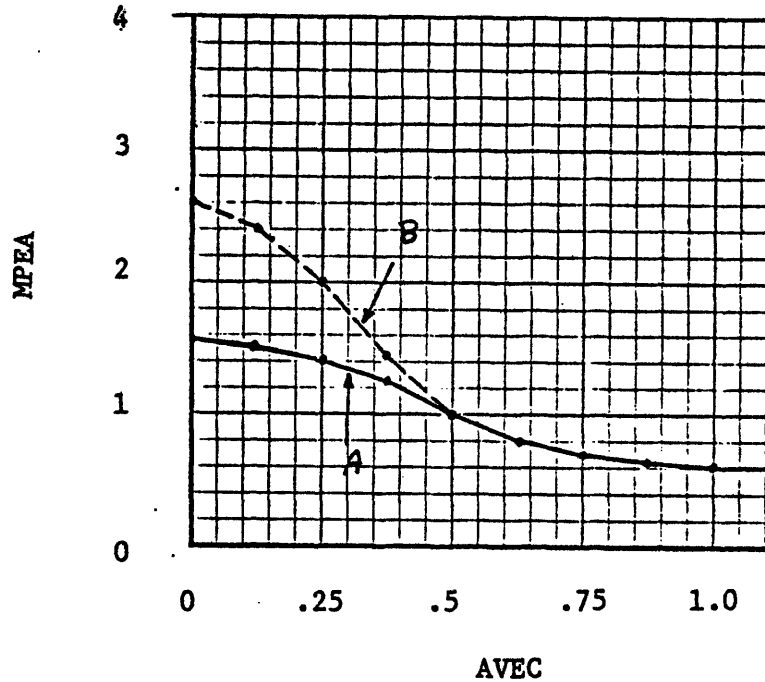

Figure A.52: The Multiplier for Production Capacity in Education from Availability Versus the Availability of Enrollment Capacity.

$MPEA.K = TEEP.K * TABLE(TMPEA, AVEC.K, 0, 2, .25) + (1 - TEEP.K) * TABLE(TMPEAT, AVEC.K, 0, 2, .25)$ 
292, A

$TMPEA = 1.55 / 1.5 / 1.4 / 1.25 / 1 / .8 / .7 / .64 / .6$ 
292.2, T

$TMPEAT = 2.6 / 2.4 / 2 / 1.45 / 1 / .8 / .7 / .64 / .6$ 
292.3, T

**MPEA** - MULTIPLIER FOR PRODUCTION CAPACITY IN EDUCATION FROM AVAILABILITY (DIMENSIONLESS)

**TEEP** - TEST OF EDUCATIONAL EXPANSION POLICY (DIMENSIONLESS)

**TMPEA** - TABLE FOR MULTIPLIER FOR PRODUCTION CAPACITY IN EDUCATION FROM AVAILABILITY

**AVEC** - AVAILABILITY OF ENROLLMENT CAPACITY (DIMENSIONLESS)

**TMPEAT** - TABLE FOR PRODUCTION CAPACITY IN EDUCATION FROM AVAILABILITY FOR POLICY TEST

education sector is not as competent as the other sectors to hire the required production resources for its expansion. Curve A, which is a better representative of the current educational expansion policy, is used in the standard run of the model. The effect of a more supportive educational policy represented by Curve B can be examined in the model.

Test for educational expansion policy TEEP, Equation 293, is equal to 1 before 1978 and equal to test for educational expansion policy constant TEEPC after 1978. TEEPC is a constant that is set at one for the simulations discussed in Chapters 4 and 5. To adopt the educational policy represented by Curve B in Figure A.52 after 1978, TEEPC should be changed to zero.

TEEP.K=CLIP(1,TEEPC,1978,TIME.K) 293, A  
TEEPC=1 293.1, C  
TEEP - TEST OF EDUCATIONAL EXPANSION POLICY  
(DIMENSIONLESS)  
CLIP - CLIP FUNCTION  
TEEPC - TEST OF EDUCATIONAL EXPANSION POLICY  
CONSTANT (DIMENSIONLESS)

The availability of enrollment capacity AVEC, Equation 294, is the ratio of enrollment capacity ECAP to social demand for education SDE.

AVEC.K=ECAP.K/SDE.K 294, A  
AVEC - AVAILABILITY OF ENROLLMENT CAPACITY  
(DIMENSIONLESS)  
ECAP - ENROLLMENT CAPACITY (STUDENTS)  
SDE - SOCIAL DEMAND FOR EDUCATION (STUDENTS)

Social demand for education SDE, Equation 295, is equal to the desired enrollment ratio DER times school-age children SAC times the duration of education DE divided by the duration of school-age period DSAP.

$$\text{SDE.K} = \text{DER.K} * (\text{SAC.K}) * (\text{DE.K} / \text{DSAP.K}) \quad 295, \text{ A}$$

SDE - SOCIAL DEMAND FOR EDUCATION (STUDENTS)  
DER - DESIRED ENROLLMENT RATIO (DIMENSIONLESS)  
SAC - SCHOOL AGE CHILDREN (PERSONS)  
DE - DURATION OF EDUCATION (YEARS)  
DSAP - DURATION OF SCHOOL-AGE PERIOD (YEARS)

The desired enrollment ratio DER, Equation 296, is a weighted average of the desired enrollment ratio from education DERE and the desired enrollment ratio from income DERI. The weighting factor is the coefficient for the desired enrollment ratio from education CDERE. CDERE is assumed to be 0.5 - i.e., the duration of education from education and income are weighted equally in the formulation of DER.

$$\text{DER.K} = \text{CDERE} * \text{DERE.K} + (1 - \text{CDERE}) * (\text{DERI.K}) \quad 296, \text{ A}$$
$$\text{CDERE} = .5 \quad 296.1, \text{ C}$$

DER - DESIRED ENROLLMENT RATIO (DIMENSIONLESS)  
CDERE - COEFFICIENT FOR DESIRED ENROLLMENT RATIO FROM EDUCATION (DIMENSIONLESS)  
DERE - DESIRED ENROLLMENT RATIO FROM EDUCATION (DIMENSIONLESS)  
DERI - DESIRED ENROLLMENT RATIO FROM INCOME (DIMENSIONLESS)

The desired enrollment ratio from education DERE, Equation 297, is a function of school years per adult population SYPAP. Figure A.53



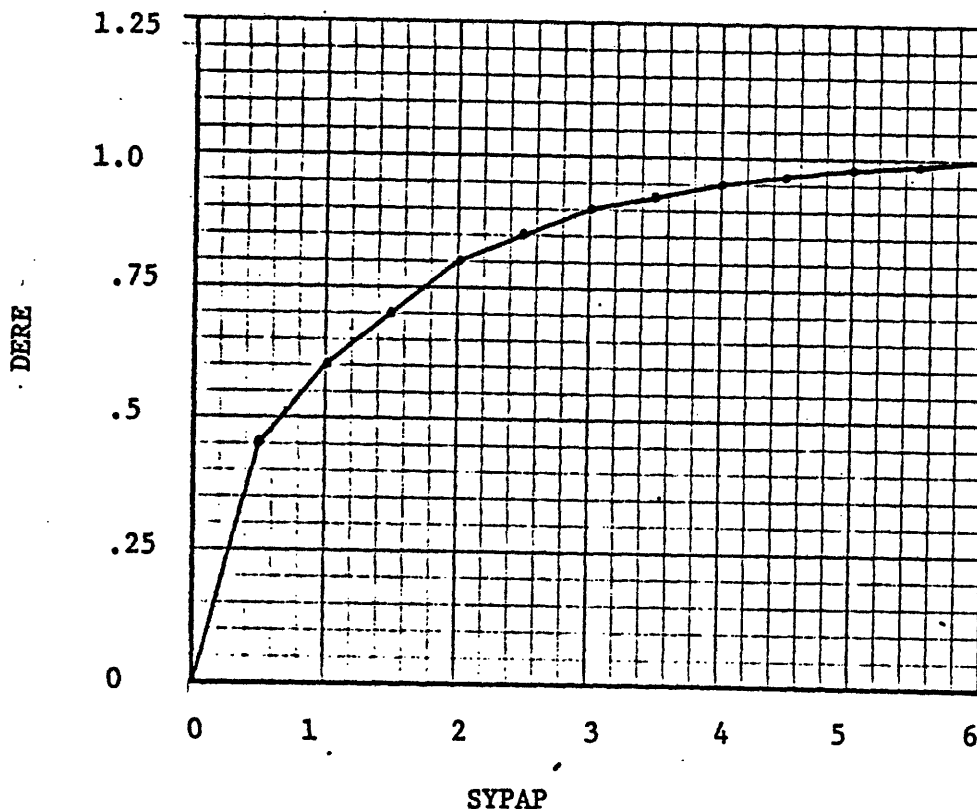

Figure A.53: The Desired Enrollment Ratio from Education Versus School-Year per Adult Population.

```
DERE.K=TABHL(TDERE,SYPAP.K,0,6,.5) 297, A
TDERE=0/.45/.6/.7/.8/.85/.9/.925/.95/.965/.98/.99/1 297.1, T
DERE - DESIRED ENROLLMENT RATIO FROM EDUCATION
(DIMENSIONLESS)
TDERE - TABLE FOR DESIRED ENROLLMENT RATIO FROM
EDUCATION
SYPAP - SCHOOL-YEARS PER ADULT POPULATION (MAN-
YEARS OF SCHOOLING/PERSON)
```

shows the relationship between DERE and SYPAP. When SYPAP is zero, indicating that there are not any educated people in the society, DERE is assumed to be zero. As SYPAP increases, DERE rises with a diminishing rate. Finally, when SYPAP becomes five, DERE levels off at 1.

The desired enrollment ratio from income DERI, Equation 297, is a function of GNP per capita GNPPC. Figure A.54 illustrates the relationship between DERI and GNPPC. When GNPPC is zero, clearly there will be no concern about education and DERI is set at zero. As GNPPC increases, so does DERI, with a diminishing rate. When GNPPC becomes 150,000 rials per capita, DERI is assumed to level off at one.

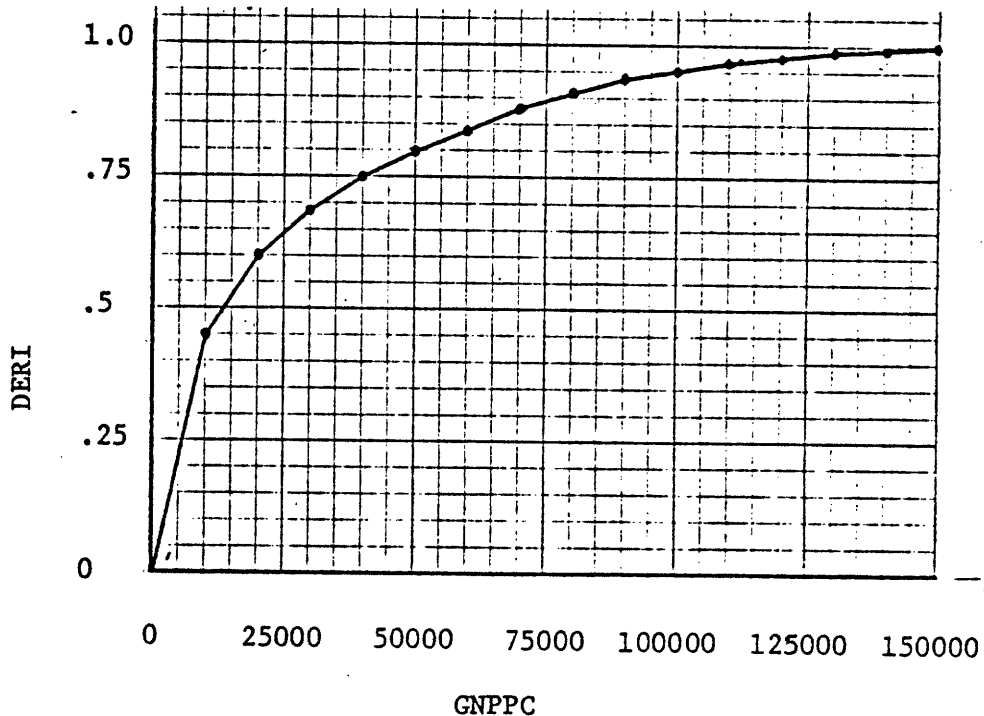

Figure A.54: The Desired Enrollment Ratio from Income Versus Gross National Product Per Capita.

DERI.K=TABHL(TDERI,GNPPC.K,0,150000,10000) 298, A  
TDERI=0/.45/.6/.69/.75/.8/.84/.88/.91/.94/.955/.97/ 298.1, T  
.98/.99/.995/1  
DERI - DESIRED ENROLLMENT RATIO FROM INCOME  
(DIMENSIONLESS)  
TDERI - TABLE FOR DESIRED ENROLLMENT RATIO FROM  
INCOME  
GNPPC - GROSS NATIONAL PRODUCT PER CAPITA (RIALS/  
YEAR/PERSON)

## A.10 TECHNOLOGY TRANSFER

### A.10.1 Technology Transfer in Industry

Technology in industrial sector TIS, Equation 301, is increased by the rate of technology transfer in industry RTTI. The initial value of technology in industrial sector TISN represents the state of technology in the industrial sector of Iran in 1959 and is defined to be one. The state of technology in the domestic industry as well as in the industrial sector of advanced countries will be two technological indices,

measured relative to the state of industrial technology in Iran in 1959.

TIS.K=TIS.J+DT*RTTI.JK	301, L
TIS=TISN	301.1, N
TISN=1	301.2, C
TIS	- TECHNOLOGY IN INDUSTRIAL SECTOR (TECHNOLOGY)
RTTI	- RATE OF TRANSFER OF TECHNOLOGY IN INDUSTRY (TECHNOLOGY/YEAR)
TISN	- TECHNOLOGY IN INDUSTRIAL SECTOR INITIAL (TECHNOLOGY)

The rate of technology transfer in industry RTTI, Equation 302, is based on the difference between technology in industrial sector of advanced country TISA and technology in industrial sector TIS, normal time to catch up in industrial technology NTIT, multiplier for technology transfer from foreign trade, and multiplier for technology transfer from education in industry MTTEI.

RTTI.KL= ((TISA.K-TIS.K)/NTIT.K)*MTTFT.K*MTTEI.K	302, R
RTTI	- RATE OF TRANSFER OF TECHNOLOGY IN INDUSTRY (TECHNOLOGY/YEAR)
TISA	- TECHNOLOGY IN INDUSTRIAL SECTOR OF ADVANCED COUNTRIES (TECHNOLOGY)
TIS	- TECHNOLOGY IN INDUSTRIAL SECTOR (TECHNOLOGY)
NTIT	- NORMAL TIME TO CATCH UP IN INDUSTRIAL TECHNOLOGY (YEARS)
MTTFT	- MULTIPLIER FOR TECHNOLOGY TRANSFER FROM FOREIGN TRADE (DIMENSIONLESS)
MTTEI	- MULTIPLIER FOR TECHNOLOGY TRANSFER FROM EDUCATION IN INDUSTRY (DIMENSIONLESS)

Technology in the industrial sector of advanced countries TISA, Equation 303, is assumed to grow exponentially with the rate of

technological progress in industry RTPI. The United States is taken as a representative of advanced countries who are in the frontier of technological development. Solow (1957) estimated that the rate of technological progress in the United States from 1909 to 1949 has been 1.5 percent per year when only capital and labor are considered as the production factors and improvement in the education of labor force is ignored. However, when the contribution of education to the growth of output is counted, in addition to the contribution of capital and labor, Denison (1967, p. 192) estimated that the rate of technological progress or the residual of the growth of output has been 1.37 percent per year in the United States during 1950-1962. In the model, RTPI, Equation 308.1, is assumed to be 1.37 percent per year.

TISA.K=TISAN*EXP(RTPI*(TIME.K-1959))	303, A
TISAN=5.176	303.1, C
RTPI=.0137	303.2, C
TISA	- TECHNOLOGY IN INDUSTRIAL SECTOR OF ADVANCED COUNTRIES (TECHNOLOGY)
TISAN	- TECHNOLOGY IN INDUSTRIAL SECTOR OF ADVANCED COUNTRIES INITIAL (TECHNOLOGY)
EXP	- EXPONENTIAL FUNCTION
RTPI	- RATE OF TECHNOLOGICAL PROGRESS IN INDUSTRY (TECHNOLOGY/YEAR)

The initial value of technology in industrial sector of advanced countries TISAN is measured relative to the level of industrial technology in Iran in 1959. The production function for the

non-agricultural, non-oil sectors of the Iranian economy in 1959 can be written as follows:

$$(a) \quad O_I = A_I \cdot TISN \cdot (L_I)^{0.4} (C_I)^{0.3} (E_I)^{0.3}$$

where the exponents of labor, capital and education are those discussed in section A.3.  $O_I$ ,  $L_I$ ,  $C_I$ , and  $E_I$  are output, labor, capital, and education in the industrial sector of the Iranian economy in 1959, respectively. TISN is the technology level in 1959, which is assumed to be one.  $A_I$  is a constant. The production function for non-farm sectors of the U.S. economy in 1959 is:

$$(b) \quad O_U = A_I \cdot TISAN \cdot (L_U)^{0.4} (C_U)^{0.3} (E_U)^{0.3}$$

where  $O_U$ ,  $L_U$ ,  $C_U$ , and  $E_U$  are output, labor, capital, and education in the non-farm sectors of the U.S. economy in 1959, respectively. TISA is the technology level in the U.S. in 1959.  $A_I$  is the same constant used in the production function for Iran.

From the production functions for the two countries, the following equation is derived:

$$(c) \quad \frac{O_U}{O_I} = \frac{TISAN}{TISN} \cdot \frac{(L_U)^{0.4} (C_U)^{0.3} (E_U)^{0.3}}{(L_I)^{0.4} (C_I)^{0.3} (E_I)^{0.3}}$$

or,

$$(d) \text{ TISAN} = \text{TISN} \cdot \frac{O_U}{O_I} \cdot \frac{(L_I)^{0.4} (C_I)^{0.3} (E_I)^{0.3}}{(L_U)^{0.4} (C_U)^{0.3} (E_U)^{0.3}}$$

By definition of technology unit, TISN is assumed to be one. Table A.8 shows output and production factors for Iran and the United States in 1959. Data presented in Table A.8 is used in Equation (d) to estimate TISAN:

$$\text{TISAN} = 1 \times \frac{33110}{217} \times \frac{(3158)^{0.4} (428.8)^{0.3} (8220)^{0.3}}{(20131)^{0.4} (111517.0)^{0.3} (211375.1)^{0.3}}$$

or,

$$\text{TISAN} = 5.176$$

TISAN is set equal to 5.176 in Equation 303.1. Since the initial value of technology in the industrial sector of Iran TISN is assumed to be one, the ratio of TISAN to TISN is 5.176. The necessary time to increase the technology with a rate of 1.37 percent per year with a factor of 5.176 is 120 years. Therefore, the ratio of TISAN to TISN implies that in 1959 Iran was technologically at the same level that the U.S. was in 1839, if we assume that the rate of technological progress in the U.S. has been 1.37% per year since 1839. The implication seems reasonable and supports the estimated value of TISAN.

TABLE A.8

Output and Production Factors in Non-Agricultural Sectors in Iran\* and the United States in 1959.

	<u>Output</u> (In billion rials at constant 1972 prices)	<u>Capital Stock</u> at constant	<u>Labor</u> (1000 persons)	<u>Education</u> (1000 man-years of schooling)
Iran	217.0	428.8	3158	8220
U.S.	33110	111517.0	20131	211375.1

\*Non-agricultural output in Iran excludes oil output.

Sources: Output, capital stock, labor, and education in Iran are from Tables A.3, A.7, and data in SRU March 1976. For the United States, output, capital stock, and labor force are based on data in "Historical Statistics of the U.S., Colonial Times to 1970." and Statistical Abstract of the U.S., 1976; the education level is based on labor force and the average years of education of labor force in 1959 given in Denison (1967, p.381). In order to convert the output and capital stock data of the U.S. from 1972 dollars to 1972 rials, one dollar is set equal to 70 rials.



The normal time to catch up in industrial technology NTIT, Equation 304, is the natural logarithm of the technology ratio in industry divided by the product of the rate of technological progress in industry RTPI and the coefficient of technological progress through transfer CTPT. CTPT is set at 1.5, assuming that, under normal education level and foreign trade activities, the technology transfer increases the rate of technological progress by 50%.

$$\begin{aligned} \text{NTIT.K} &= \text{LOGN}(\text{TERIS.K}) / (\text{RTPI} * \text{CTPT}) && 304, \text{ A} \\ \text{CTPT} &= 1.5 && 304.1, \text{ C} \end{aligned}$$

NTIT - NORMAL TIME TO CATCH UP IN INDUSTRIAL TECHNOLOGY (YEARS)

TERIS - TECHNOLOGY RATIO IN INDUSTRIAL SECTOR (DIMENSIONLESS)

RTPI - RATE OF TECHNOLOGICAL PROGRESS IN INDUSTRY (TECHNOLOGY/YEAR)

CTPT - COEFFICIENT FOR TECHNOLOGICAL PROGRESS THROUGH TRANSFER (DIMENSIONLESS)

Technology ratio in industry TERIS, Equation 305, is the ratio of technology in industrial sector of advanced countries TISA to technology in industrial sector TIS.

$$\text{TERIS.K} = \text{TISA.K} / \text{TIS.K} \quad 305, \text{ A}$$

TERIS - TECHNOLOGY RATIO IN INDUSTRIAL SECTOR (DIMENSIONLESS)

TISA - TECHNOLOGY IN INDUSTRIAL SECTOR OF ADVANCED COUNTRIES (TECHNOLOGY)

TIS - TECHNOLOGY IN INDUSTRIAL SECTOR (TECHNOLOGY)

Multiplier for technology transfer from foreign trade MTTFT, Equation 306, is a function of foreign trade ratio FTR to foreign trade ratio normal FTRN. Figure A.55 shows the functional relationship between MTTFT and (FTR/FTRN). Foreign trade ratio normal FTRN is assumed to be 12 percent (of non-oil output). When FTR is equal to FTRN - i.e., (FTR/FTRN) is one - MTTFT is one. As FTR increases, so does MTTFT, and vice versa.

Foreign trade ratio FTR, Equation 307, is the ratio of total imports to non-oil output NOO.

$$FTR.K = TI.JK / NOO.K \quad 307, A$$

FTR	- FOREIGN TRADE RATIO (DIMENSIONLESS)
TI	- TOTAL IMPORTS (1E6 RIALS/YEAR)
NOO	- NON-OIL OUTPUT (1E6 RIALS/YEAR)

Equation 308, as diagrammed in Figure A.56, determines the multiplier for technology transfer from education in industry MTTEI as a function of technology normal to technology ratio in industry TNTRI. When TNTRI is zero, indicating that the normal technology level in industry is zero, MTTEI is also zero. When technology level in industry is at its normal level implied by the education level of the labor force, TNTRI is one and so is MTTEI. As TNTRI increases, so does MTTEI, with a diminishing rate.

Equation 309 calculates technology normal to technology ratio, as the ratio of technology normal in industry TNI to technology in

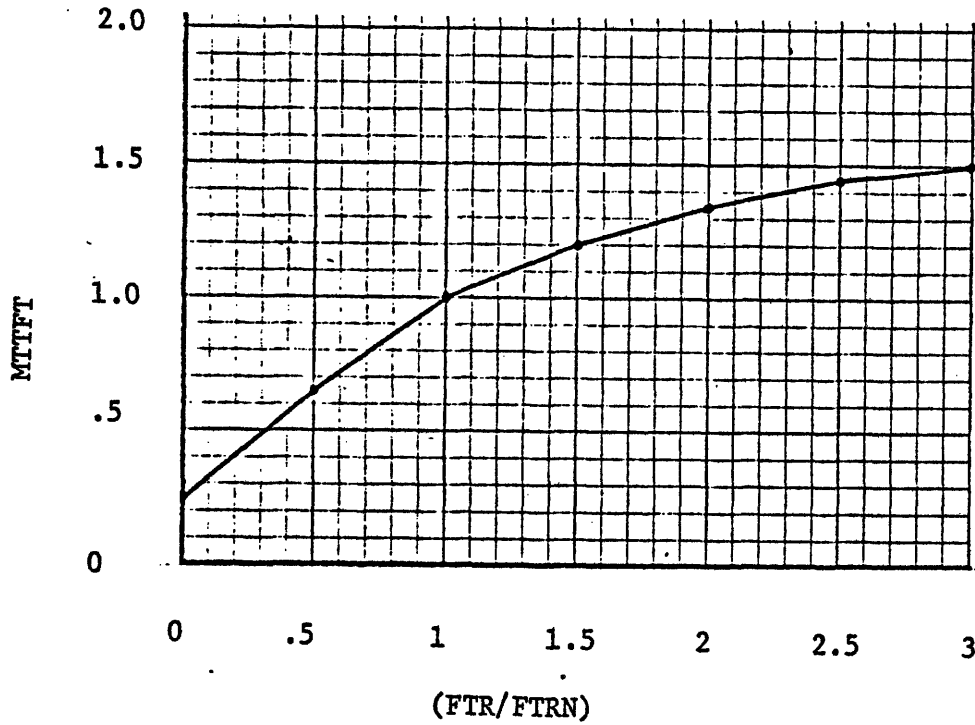

Figure A.55: The Multiplier for Technology Transfer from Foreign Trade Versus the Ratio of Foreign Trade Ratio to Foreign Trade Ratio Normal.

```
MTTFT.K=TABHL(TMTTFT,(FTR.K/FTRN),0,3,.5)           306, A
TMTTFT=.25/.65/1/1.2/1.35/1.45/1.5                 306.1, T
FTRN=.12                                             306.2, C
MTTFT - MULTIPLIER FOR TECHNOLOGY TRANSFER FROM
        FOREIGN TRADE (DIMENSIONLESS)
TMTTFT - TABLE FOR MULTIPLIER FOR TECHNOLOGY
        TRANSFER FROM FOREIGN TRADE
FTR    - FOREIGN TRADE RATIO (DIMENSIONLESS)
FTRN   - FOREIGN TRADE RATIO NORMAL (DIMENSIONLESS)
```

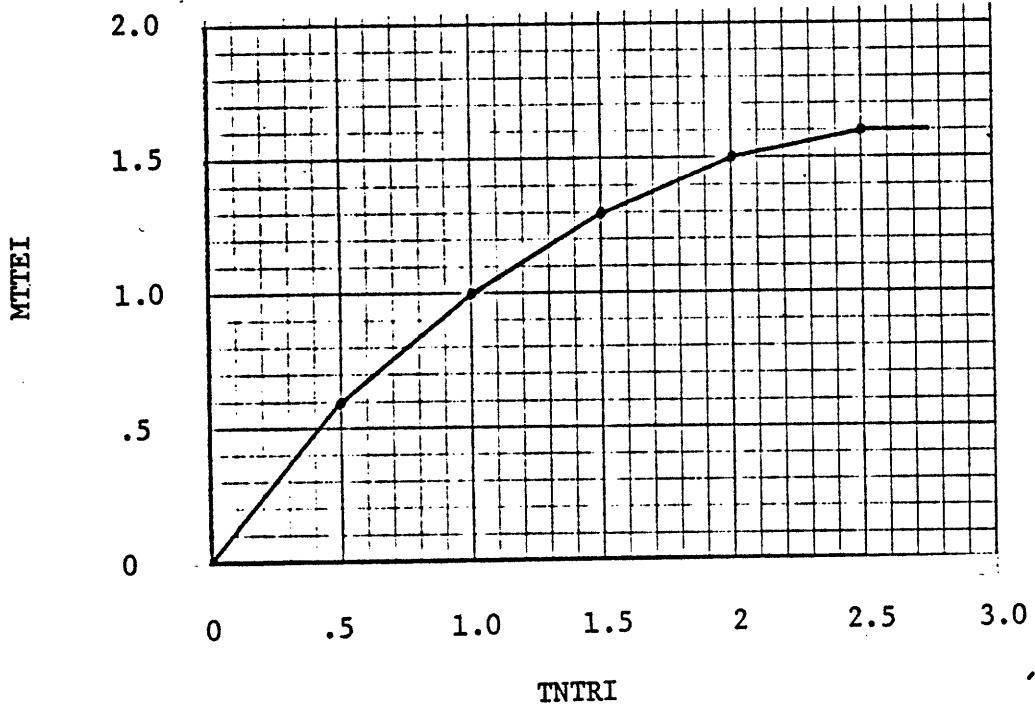

Figure A.56: The Multiplier for Technology Transfer from Education in Industry Versus Technology Normal to Technology Ratio in Industry.

```
MTTEI.K=TABHL(TMTTI,TNTRI.K,0,2.5,.5)           308, A
TMTTI=0/.6/1/1.3/1.5/1.6                       308.1, T
MTTEI - MULTIPLIER FOR TECHNOLOGY TRANSFER FROM
        EDUCATION IN INDUSTRY (DIMENSIONLESS)
TMTTI - TABLE FOR MULTIPLIER FOR TECHNOLOGY
        TRANSFER FROM EDUCATION IN INDUSTRY
TNTRI - TECHNOLOGY NORMAL TO TECHNOLOGY IN INDUSTRY
        (DIMENSIONLESS)
```

industry TIS.

$$\text{TNTRI.K} = \text{TNI.K} / \text{TIS.K} \quad 309, \text{ A}$$

TNTRI - TECHNOLOGY NORMAL TO TECHNOLOGY IN INDUSTRY  
(DIMENSIONLESS)

TNI - TECHNOLOGY NORMAL IN INDUSTRY (TECHNOLOGY)

TIS - TECHNOLOGY IN INDUSTRIAL SECTOR  
(TECHNOLOGY)

Equation 310 determines the technology normal in industry TNI as the product of the technology index in industry TEIT and technology in industrial sector of advanced countries TISA.

$$\text{TNI.K} = \text{TEII.K} * \text{TISA.K} \quad 310, \text{ A}$$

TNI - TECHNOLOGY NORMAL IN INDUSTRY (TECHNOLOGY)

TEII - TECHNOLOGY INDEX FOR INDUSTRY  
(DIMENSIONLESS)

TISA - TECHNOLOGY IN INDUSTRIAL SECTOR OF ADVANCED  
COUNTRIES (TECHNOLOGY)

Equation 311, as diagrammed in Figure A.57, determines the technology index in industry TEII as a function of the ratio of school-years per laborer in industry SYPLI to the school-years per industrial laborer of advanced countries SYPILA. When SYPLI is zero, TEII is assumed to be zero. As (SYPLI/SYPILA) rises, so does TEII.

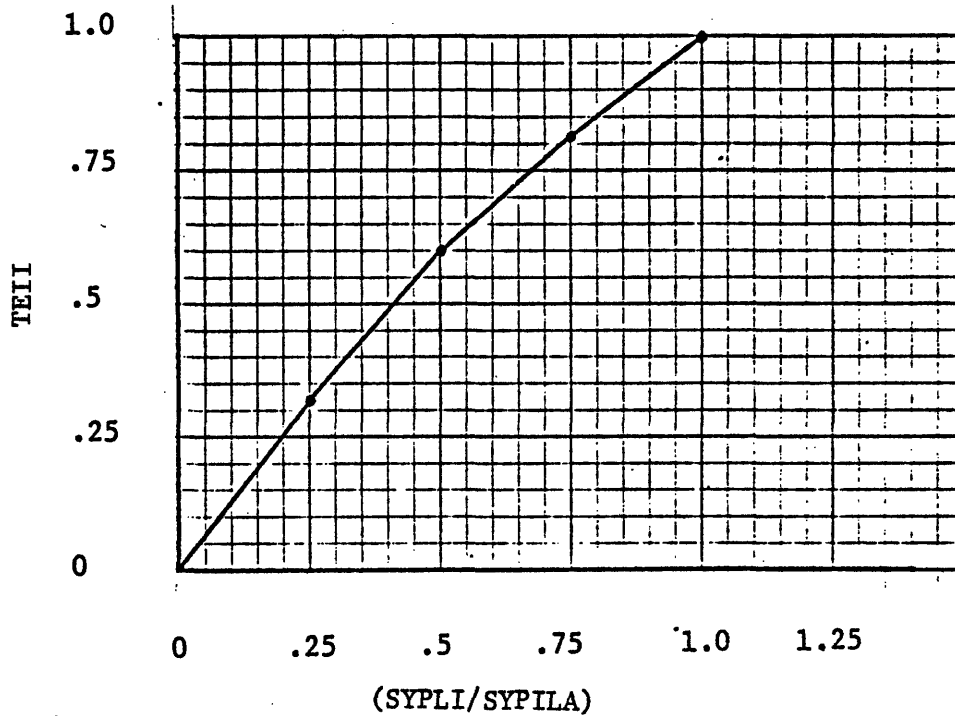

Figure A.57: The Technology Index in Industry Versus the Ratio of School-Years per Laborer in Industry to School-Years per Industrial Laborer of Advanced Countries.

```
TEII.K=TABHL(TTEI, (SYPLI.K/SYPILA.K), 0, 1, .25)      311, A
TTEI=0/.32/.6/.82/1                                  311.1, T
TEII - TECHNOLOGY INDEX FOR INDUSTRY
        (DIMENSIONLESS)
TTEI - TABLE FOR TECHNOLOGY INDEX IN INDUSTRY
SYPLI - SCHOOL-YEARS PER LABORER IN INDUSTRY
        (YEARS-OF-SCHOOLING/PERSON)
SYPILA - SCHOOL-YEARS PER INDUSTRIAL LABORER OF
        ADVANCED COUNTRIES (YEARS-OF-SCHOOLING/
        PERSON)
```

School years per laborer in industry SYPLI, Equation 312, is the ratio of education in industrial sector EIS to the labor in industrial sector LIS.

$$\text{SYPLI.K} = (1000 * \text{EIS.K}) / \text{LIS.K} \quad 312, A$$

SYPLI - SCHOOL-YEARS PER LABORER IN INDUSTRY  
(YEARS-OF-SCHOOLING/PERSON)  
EIS - EDUCATION IN INDUSTRIAL SECTOR (1000 MAN-YEARS-OF-SCHOOLING)  
LIS - LABOR IN INDUSTRIAL SECTOR (PERSONS)

School years per industrial laborer in advanced country SYPILA, Equation 313, is assumed to be 12 years throughout the simulation.

$$\text{SYPILA.K} = 12 \quad 313, A$$

SYPILA - SCHOOL-YEARS PER INDUSTRIAL LABORER OF  
ADVANCED COUNTRIES (YEARS-OF-SCHOOLING/  
PERSON)

#### A.10.2 Technology Transfer in Agriculture

Equations 314 to 329 that follow represent the formulation of the technology transfer in agriculture. The equations are similar to those explained for the technology transfer in industry. The initial value of technology in agriculture TASN, Equation 314.1, is defined to be one. The initial value of technology in agricultural sector of advanced countries TASAN, Equation 316.1, is assumed to be 4, relative to TASN. The rate of technological progress in agricultural sector RTPA is assumed to be 1

percent per year, smaller than the rate estimated for non-agricultural sector. School years per laborer in agricultural sector of advanced countries SYPLAA, Equation 325, is set at 8 years of schooling per laborer.

TAS.K=TAS.J+DT\*RTTA.JK 314, L  
TAS=TASN 314.1, N  
TASN=1 314.2, C

TAS - TECHNOLOGY IN AGRICULTURAL SECTOR  
(TECHNOLOGY)  
RTTA - RATE OF TECHNOLOGY TRANSFER IN AGRICULTURAL  
SECTOR (TECHNOLOGY/YEAR)  
TASN - TECHNOLOGY IN AGRICULTURAL SECTOR INITIAL  
(TECHNOLOGY)

RTTA.KL= ((TASA.K-TAS.K)/NTAT.K)\*MTTFTA.K\*MTTEA.K 315, R  
RTTA - RATE OF TECHNOLOGY TRANSFER IN AGRICULTURAL  
SECTOR (TECHNOLOGY/YEAR)  
TASA - TECHNOLOGY IN AGRICULTURAL SECTOR OF  
ADVANCED COUNTRIES (TECHNOLOGY)  
TAS - TECHNOLOGY IN AGRICULTURAL SECTOR  
(TECHNOLOGY)  
NTAT - NORMAL TIME TO CATCH UP IN AGRICULTURAL  
TECHNOLOGY (YEARS)  
MTTFTA - MULTIPLIER FOR TECHNOLOGY TRANSFER FROM  
FOREIGN TRADE IN AGRICULTURE  
(DIMENSIONLESS)  
MTTEA - MULTIPLIER FOR TECHNOLOGY TRANSFER FROM  
EDUCATION IN AGRICULTURE (DIMENSIONLESS)

TASA.K=TASAN\*EXP(RTPA\*(TIME.K-1959)) 316, A  
TASAN=4 316.1, C  
RTPA=.01 316.2, C

TASA - TECHNOLOGY IN AGRICULTURAL SECTOR OF  
ADVANCED COUNTRIES (TECHNOLOGY)  
TASAN - TECHNOLOGY IN AGRICULTURAL SECTOR OF  
ADVANCED COUNTRIES INITIAL (TECHNOLOGY)  
EXP - EXPONENTIAL FUNCTION  
RTPA - RATE OF TECHNOLOGICAL PROGRESS IN  
AGRICULTURE (TECHNOLOGY/YEAR)



- NTAT.K=LOGN(TERAS.K)/(RTPA\*CTPT) 317, A  
NTAT - NORMAL TIME TO CATCH UP IN AGRICULTURAL TECHNOLOGY (YEARS)  
TERAS - TECHNOLOGY RATIO IN AGRICULTURAL SECTOR (DIMENSIONLESS)  
RTPA - RATE OF TECHNOLOGICAL PROGRESS IN AGRICULTURE (TECHNOLOGY/YEAR)  
CTPT - COEFFICIENT FOR TECHNOLOGICAL PROGRESS THROUGH TRANSFER (DIMENSIONLESS)
- TERAS.K=TASA.K/TAS.K 318, A  
TERAS - TECHNOLOGY RATIO IN AGRICULTURAL SECTOR (DIMENSIONLESS)  
TASA - TECHNOLOGY IN AGRICULTURAL SECTOR OF ADVANCED COUNTRIES (TECHNOLOGY)  
TAS - TECHNOLOGY IN AGRICULTURAL SECTOR (TECHNOLOGY)
- MTTFTA.K=TABHL(TMTTFA,(FTR.K/FTRN),0,3,.5) 319, A  
TMTTFA=.25/.65/1/1.2/1.35/1.45/1.50 319.1, T  
MTTFTA - MULTIPLIER FOR TECHNOLOGY TRANSFER FROM FOREIGN TRADE IN AGRICULTURE (DIMENSIONLESS)  
TMTTFA - TABLE FOR MULTIPLIER FOR TECHNOLOGY TRANSFER FROM FOREIGN TRADE IN AGRICULTURE  
FTR - FOREIGN TRADE RATIO (DIMENSIONLESS)  
FTRN - FOREIGN TRADE RATIO NORMAL (DIMENSIONLESS)
- MTTEA.K=TABHL(TMTTA,TNTRA.K,0,2.5,.5) 320, A  
TMTTA=0/.6/1/1.3/1.5/1.6 320.1, T  
MTTEA - MULTIPLIER FOR TECHNOLOGY TRANSFER FROM EDUCATION IN AGRICULTURE (DIMENSIONLESS)  
TMTTA - TABLE FOR MULTIPLIER FOR TECHNOLOGY TRANSFER FROM EDUCATION IN AGRICULTURE  
TNTRA - TECHNOLOGY NORMAL TO TECHNOLOGY IN AGRICULTURAL SECTOR (DIMENSIONLESS)
- TNTRA.K=TNA.K/TAS.K 321, A  
TNTRA - TECHNOLOGY NORMAL TO TECHNOLOGY IN AGRICULTURAL SECTOR (DIMENSIONLESS)  
TNA - TECHNOLOGY NORMAL IN AGRICULTURE (TECHNOLOGY)  
TAS - TECHNOLOGY IN AGRICULTURAL SECTOR (TECHNOLOGY)
- TNA.K=TEIA.K\*TASA.K 322, A  
TNA - TECHNOLOGY NORMAL IN AGRICULTURE (TECHNOLOGY)  
TEIA - TECHNOLOGY INDEX IN AGRICULTURAL SECTOR (DIMENSIONLESS)  
TASA - TECHNOLOGY IN AGRICULTURAL SECTOR OF ADVANCED COUNTRIES (TECHNOLOGY)

TEIA.K=TABHL(TTEIA,(SYPLA.K/SYPLAA.K),0,1,.25) 323, A  
TTEIA=0/.32/.6/.82/1 323.1, T

TEIA - TECHNOLOGY INDEX IN AGRICULTURAL SECTOR  
(DIMANSIONLESS)

TTEIA - TABLE FOR TECHNOLOGY INDEX IN AGRICULTURAL  
SECTOR FROM EDUCATION

SYPLA - SCHOOL YEARS PER LABOR IN AGRICULTURAL  
SECTOR (YEARS OF SCHOOLING/PERSON)

SYPLAA - SCHOOL YEARS PER LABOR IN AGRICULTURAL  
SECTOR OF ADVANCED COUNTRIES (YEARS OF  
SCHOOLING/PERSON)

SYPLA.K=(EAS.K\*1000)/LAS.K 324, A

SYPLA - SCHOOL YEARS PER LABOR IN AGRICULTURAL  
SECTOR (YEARS OF SCHOOLING/PERSON)

EAS - EDUCATION IN AGRICULTURAL SECTOR (1000 MAN-  
YEARS-OF-SCHOOLING)

LAS - LABOR IN AGRICULTURAL SECTOR (PERSONS)

SYPLAA.K=8 325, A

SYPLAA - SCHOOL YEARS PER LABOR IN AGRICULTURAL  
SECTOR OF ADVANCED COUNTRIES (YEARS OF  
SCHOOLING/PERSON)

Footnotes

<sup>1</sup>The adult population in 1959 was derived by extrapolation of available data for 1956 and 1966 in Iran Statistical Yearbook 1350 (Farsi Version, p.35).

<sup>2</sup>See "The Measurement of Population Growth in Iran, 2535 (in Farsi) by Statistical Center of Plan and Budget Organization, 1976.

<sup>3</sup>Based on imports and exports of agricultural products, and value added in agricultural sector (taken as equal to the value of output of the sector). The total expenditure on food in 1974 is estimated as 278.9 billion rials at 1972 constant prices. The population in 1974 was 32,496,000. Therefore, food per capita in 1974 would be:

$$\begin{aligned} \text{NFPC} &= \frac{278.9 \times 10^9}{32496000} \\ &= 8582 \text{ rials per person per year.} \end{aligned}$$

<sup>4</sup>From SRU March 1976. In 1974, the value added in the non-oil, non-agricultural sector of the economy was 1097 billion rials at 1972 prices. The population of Iran in 1974 was 32,496,000. Therefore, industrial output per capita in 1974 would be:

$$\text{NIPC} = \frac{1097 \times 10^9}{32496000} = 33758.$$

<sup>5</sup>For the value of the death rate in 1974, see "The Measurement of Population Growth in Iran" (in Farsi), The Statistical Center of Plan and Budget Organization 2535 (1976), p. 37.

<sup>6</sup>For the value of the death rate in 1974, see "The Measurement of Population Growth in Iran" (in Farsi), The Statistical Center of Plan and Budget Organization 2535 (1976), p.37.

<sup>7</sup>For the number of new students entering the first grade of the school system, see The Ministry of Education, Educational Statistics of Iran, 1976, p. 48.



APPENDIX B: MODEL EQUATIONS

Following are the model equations used for the simulation of Iran's economic development in this thesis. Equation descriptions are found in Appendix A. Numbers on the left of each equation, when divided by ten, give the equation number used in Appendix A and DYNAMO flow diagrams of Chapter 3.

THES.DYNAMO

0001 =====  
0002 =====  
0003  
0004 A MODEL OF IRAN ECONOMIC GROWTH  
0005  
0006 =====  
0007 =====

0012 \*\*\*\*\*

0014 1. ALLOCATION OF PRODUCTION FACTORS BETWEEN AGRICULTURAL  
0015 AND INDUSTRIAL SECTORS

0016 \*\*\*\*\*

0019 -----

0022 1.1 ALLOCATION OF LABOR

0024 -----

0030 A LAS.K=FLA.K\*L.K  
0040 A LIS.K=(1-FLA.K)\*L.K  
0050 A FLA.K=ADLAS.K/(ADLAS.K+ADLIS.K)  
0060 L ADLAS.K=ADLAS.J+DT\*((DLAS.J-ADLAS.J)/TAL)  
0061 N ADLAS=ADLASN  
0062 C ADLASN=3417000  
0063 C TAL=15  
0070 L ADLIS.K=ADLIS.J+DT\*((DLIS.J-ADLIS.J)/TAL)  
0071 N ADLIS=ADLISN  
0072 C ADLISN=3158000  
0080 A DLAS.K=MLAS.K\*LAS.K  
0090 A DLIS.K=MLIS.K\*LIS.K  
0100 A MLAS.K=TABHL(TMLAS,ULRA.K,0,5,1)  
0101 T TMLAS=0/1/1.8/2.4/2.8/3.0  
0110 A MLIS.K=TABHL(TMLIS,ULRI.K,0,5,1)  
0111 T TMLIS=0/1/1.8/2.4/2.8/3.0  
0120 A ULRA.K=MULAS.K/AMUL.K  
0130 A ULRI.K=MULIS.K/AMUL.K  
0140 A AMUL.K=FLA.K\*MULAS.K+(1-FLA.K)\*MULIS.K  
0150 A MULAS.K=MUFA.K\*MPLAS.K  
0160 A MULIS.K=MUGA.K\*MPLIS.K  
0170 A MUFA.K=TABHL(TMUFA,FA.K,0,2.5,.25)  
0171 T TMUFA=30/10/4/1.8/1/.7/.5/.35/.25/.2/.18  
0180 A MUGA.K=TABHL(TMUGA,GAI.K,0,2.5,.5)  
0181 T TMUGA=2.5/1.5/1/.8/.65/.6  
0190 A GAI.K=FPCAP.K\*AVCAG.K+FPI.K\*AVIG.K+FPCON.K\*AVCOG.K+FPE.K\*AVEC.K  
0191

0192  
0193 -----  
0194  
0195 1.2 ALLOCATION OF CAPITAL  
0196  
0197 -----  
0198  
0199  
0200 A  $CAPAS.K = FCA.K * CAP.K$   
0210 A  $CAPIS.K = (1 - FCA.K) * CAP.K$   
0220 A  $FCA.K = ADCAS.K / (ADCAS.K + ADCIS.K)$   
0230 L  $ADCAS.K = ADCAS.J + DT * ((DCAS.J - ADCAS.J) / TAC)$   
0231 N  $ADCAS = ADCASN$   
0232 C  $ADCASN = 70500$   
0233 C  $TAC = 20$   
0240 L  $ADCIS.K = ADCIS.J + DT * ((DCIS.J - ADCIS.J) / TAC)$   
0241 N  $ADCIS = ADCISN$   
0242 C  $ADCISN = 428800$   
0250 A  $DCAS.K = CAPAS.K * MCAS.K$   
0260 A  $DCIS.K = CAPIS.K * MCIS.K$   
0270 A  $MCAS.K = TABHL(TMCAS, UCRA.K, 0, 5, 1)$   
0271 T  $TMCAS = 0 / 1 / 1.8 / 2.4 / 2.8 / 3$   
0280 A  $MCIS.K = TABHL(TMCIS, UCRI.K, 0, 5, 1)$   
0281 T  $TMCIS = 0 / 1 / 1.8 / 2.4 / 2.8 / 3$   
0290 A  $UCRA.K = MUCAS.K / AMUC.K$   
0300 A  $UCRI.K = MUCIS.K / AMUC.K$   
0310 A  $AMUC.K = FCA.K * MUCAS.K + (1 - FCA.K) * MUCIS.K$   
0320 A  $MUCAS.K = MUFA.K * MPCAS.K$   
0330 A  $MUCIS.K = MUGA.K * MPCIS.K$   
0331  
0332  
0333 -----  
0334  
0335 1.3 ALLOCATION OF EDUCATION  
0336  
0337 -----  
0338  
0339  
0340 A  $EAS.K = FEA.K * E.K$   
0350 A  $EIS.K = (1 - FEA.K) * E.K$   
0360 A  $FEA.K = ADEAS.K / (ADEAS.K + ADEIS.K)$   
0370 L  $ADEAS.K = ADEAS.J + DT * ((DEAS.J - ADEAS.J) / TAE)$   
0371 N  $ADEAS = ADEASN$   
0372 C  $ADEASN = 1780$   
0373 C  $TAE = 15$   
0380 L  $ADEIS.K = ADEIS.J + DT * ((DEIS.J - ADEIS.J) / TAE)$   
0381 N  $ADEIS = ADEISN$   
0382 C  $ADEISN = 8220$   
0390 A  $DEAS.K = MEAS.K * EAS.K$   
0400 A  $DEIS.K = MEIS.K * EIS.K$   
0410 A  $MEAS.K = TABHL(TMEAS, UERA.K, 0, 5, 1)$   
0411 T  $TMEAS = 0 / .8 / 1.5 / 2 / 2.3 / 2.5$

0420 A MEIS.K=TABHL(TMEIS, UERI.K, 0, 5, 1)  
0421 T TMEIS=0/1.25/2.2/2.9/3.3/3.5  
0430 A UERA.K=MUEAS.K/AMUE.K  
0440 A UERI.K=MUEIS.K/AMUE.K  
0450 A AMUE.K=FEA.K\*MUEAS.K+(1-FEA.K)\*MUEIS.K  
0460 A MUEAS.K=MUFA.K\*MPEAS.K  
0470 A MUEIS.K=MUGA.K\*MPEIS.K  
0471  
0472  
0473  
0474 \*\*\*\*\*  
0475  
0476 2. AGRICULTURAL SECTOR  
0477  
0478 \*\*\*\*\*  
0479  
0481  
0490 A FA.K=TF.K/DDF.K  
0500 A TF.K=FOUT.K+IF.K-EF.K  
0510 A FOUT.K=FOL.K\*(LAS.K/1000000)  
0520 A FOL.K=MFOLO.K\*(PFOL.K-PRFOL.K)+PRFOL.K  
0530 A PRFOL.K=TABHL(TPRFOL, ((LAND/LAS.K)/LLRN), 0, 2, .5)\*PRFOLN  
0531 T TPRFOL=0/.6/1/1.2/1.3  
0532 C LLRN=2.52  
0533 C PRFOLN=30000  
0534 C LAND=9271000  
0540 A MFOLO.K=TABHL(TMPFO, OAVI.K, 0, 1, .2)  
0541 T TMPFO=.5/.58/.7/.85/.95/1  
0550 A PFOL.K=(FOUT.K/LAS.K)\*1000000  
0560 A FOUT.K=FOUTC\*(EXP(ELA\*LOGN(LAS.K)))(EXP(ECA\*LOGN(CAPAS.K)))(  
0561 X (EXP(EEA\*LOGN(EAS.K)))\*TAS.K  
0562 C FOUTC=11.83  
0563 C ELA=.45  
0564 C EEA=.2  
0565 C ECA=.10  
0570 A MPLAS.K=(ELA/LAS.K)\*FOUT.K  
0580 A MPCAS.K=(ECA/CAPAS.K)\*FOUT.K  
0590 A MPEAS.K=(EEA/EAS.K)\*FOUT.K  
0591  
0592  
0593  
0594 \*\*\*\*\*  
0595  
0596 3. DETERMINATION AND ALLOCATION OF PRODUCTIVE CAPACITY  
0597 IN THE INDUSTRIAL SECTOR  
0598  
0599 \*\*\*\*\*  
0601  
0602  
0610 A PCIS.K=(LIS.K\*PCLI.K)/1000000  
0620 A PCLI.K=MPCLIO.K\*(PPCLI.K-PRPCLI)+PRPCLI  
0621 C PRPCLI=30000



0630 A MPCLIO.K=TABHL(TMPCI,OAVI.K,0,1,.2)  
0631 T TMPCI=.5/.58/.7/.85/.95/1  
0640 A PPCLI.K=(PPCIS.K/LIS.K)\*1000000  
0650 A PPCIS.K=PCIC\*(EXP(ELI\*LOGN(LIS.K)))(EXP(ECI\*LOGN(CAPIS.K)))  
0651 X (EXP(EEI\*LOGN(EIS.K)))\*TIS.K  
0652 C PCIC=.824  
0653 C ELI=.4  
0654 C ECI=.3  
0655 C EEI=.3  
0660 A OAVI.K=(OIL.K/DDE.K)/NRC  
0661 C NRC=15  
0670 A DDE.K=(DEPNO.K\*PNOO.K)/1E9  
0680 A DEPNO.K=TABHL(TDEPNO,PNOPC.K,0,100000,25000)  
0681 T TDEPNO=0/90/110/120/120  
0690 A PNOPC.K=(PNOO.K\*1000000)/(POP.K)  
0700 A PNOO.K=PPCIS.K+PFOUT.K  
0710 A MPLIS.K=(ELI/LIS.K)\*IOUT.K  
0720 A MPCIS.K=(ECI/CAPIS.K)\*IOUT.K  
0730 A MPEIS.K=(EEI/EIS.K)\*IOUT.K  
0740 A IOUT.K=VACON.K+VACAP.K+OUTI.K+PCE.K  
0741  
0742  
0743  
0744 -----  
0745  
0746 3.1 CONSUMPTION GOODS SECTOR  
0747 -----  
0748  
0749  
0751  
0760 A OUTCON.K=VACON.K\*(1+IVARCO.K)  
0770 A IVARCO.K=TABHL(TIVARC,((PCCON.K\*1000000)/POP.K),0,50000,10000)  
0771 T TIVARC=0/.18/.26/.30/.33/.35  
0780 A VACON.K=PCCON.K\*UFCO.K  
0790 A UFCO.K=UFCOD.K\*UFCOIA.K  
0800 A UFCOIA.K=TABHL(TUFCO,AVIG.K,0,1,.25)  
0801 T TUFCO=0/.15/.5/.85/1  
0810 A UFCOD.K=TABHL(TUFCOD,AAVCO.K,.75,2,.25)  
0811 T TUFCOD=1/1/.85/.72/.63/.6  
0820 A AAVCO.K=SMOOTH(AVCOG.K,TAAVCO)  
0821 C TAAVCO=1  
0822 N AAVCO=1  
0830 A PCCON.K=PPCON.K\*PRCON.K  
0840 A PRCON.K=TABHL(TPRCO,EXICON.K,0,1,.2)  
0841 T TPRCO=0/.45/.70/.85/.95/1  
0850 A EXICON.K=EXCON.K/PPCON.K  
0860 A EXCON.K=SMOOTH(VACON.K,TAEXCO)  
0861 C TAEXCO=5  
0862 N EXCON=EXCONN  
0863 C EXCONN=160000

0870 A  $PPCON.K = FPCON.K * PCIS.K$   
0880 A  $FPCON.K = (ADPCON.K) / (ADPCON.K + ADPI.K + ADPCAP.K + ADPE.K)$   
0890 A  $ADPCON.K = SMOOTH(DPCON.K, TADPCON)$   
0891 C  $TADPCON = 20$   
0892 N  $ADPCON = 200000$   
0900 A  $DPCON.K = PPCON.K * MPCONA.K * MPCOCU.K * MPCOPR.K$   
0910 A  $MPCOCU.K = TABHL(TMPCOU, UFCO.K, 0, 1, .2)$   
0911 T  $TMPCOU = 0/.4/.7/.85/.95/1$   
0920 A  $MPCOPR.K = TABHL(TMPCOP, PRRCO.K, 0, 3, .5)$   
0921 T  $TMPCOP = 0/.6/1/1.3/1.55/1.7/1.8$   
0930 A  $PRRCO.K = PRCON.K / APRIS.K$   
0940 A  $APRIS.K = (FPCON.K * PRCON.K + FPI.K * PRI.K + FPCAP.K * PRCAP.K) / (FPCON.K + FPI.K + FPCAP.K)$   
0941 X  
0950 A  $MPCONA.K = TABLE(TMPCOA, AVICOG.K, 0, 2, .25)$   
0951 T  $TMPCOA = 2.6/2.4/2/1.45/1/.8/.7/.64/.60$   
0960 A  $AVICOG.K = MEC * AVCOG.K + (1 - MEC) * (OUTCON.K / DCONG.K)$   
0961 C  $MEC = .5$   
0970 A  $AVCOG.K = TCONG.K / DCONG.K$   
0980 A  $DCONG.K = DDCONG.K + ECONG.K + DDCONS.K$   
0990 A  $TCONG.K = OUTCON.K + ICONG.K - ECONG.K$   
0991  
0992  
0993  
0994 -----  
0995  
0996 3.2 CAPITAL GOODS SECTOR  
0997 -----  
0998  
0999  
1001  
1010 A  $OUTCAP.K = VACAP.K * (1 + IVARCA)$   
1011 C  $IVARCA = 2$   
1020 A  $VACAP.K = PCCAP.K * UFCA.K$   
1030 A  $UFCA.K = UFCAD.K * UFCAIA.K$   
1040 A  $UFCAIA.K = TABHL(TUFCA, AVIG.K, 0, 1, .25)$   
1041 T  $TUFCA = 0/.15/.4/.8/1$   
1050 A  $UFCAD.K = TABHL(TUFCAD, AAVCA.K, .75, 2, .25)$   
1051 T  $TUFCAD = 1/1/.85/.7/.63/.6$   
1060 A  $AAVCA.K = SMOOTH(AVCAG.K, TAAVCA)$   
1061 C  $TAAVCA = 1$   
1062 N  $AAVCA = 1$   
1070 A  $PCCAP.K = PPCAP.K * PRCAP.K$   
1080 A  $PRCAP.K = TABHL(TPRCA, EXICAP.K, 0, 1, .2)$   
1081 T  $TPRCA = 0/.45/.70/.85/.95/1$   
1090 A  $EXICAP.K = EXCAP.K / PPCAP.K$   
1100 A  $EXCAP.K = SMOOTH(VACAP.K, TAEXCA)$   
1101 C  $TAEXCA = 10$   
1102 N  $EXCAP = EXCAPN$

1103 C EXCAPN=640  
1110 A PPCAP.K=FPCAP.K\*PCIS.K  
1120 A FPCAP.K=(ADPCAP.K)/(ADPCON.K+ADPI.K+ADPCAP.K+ADPE.K)  
1130 A ADPCAP.K=SMOOTH(DPCAP.K,TADPCA)  
1131 C TADPCA=20  
1132 N ADPCAP=800  
1140 A DPCAP.K=PPCAP.K\*MPCAPA.K\*MPCACU.K\*MPCAPR.K  
1150 A MPCACU.K=TABHL(TMPCAU,UFCA.K,0,1,.2)  
1151 T TMPCAU=0/.4/.7/.85/.95/1  
1160 A MPCAPR.K=TABHL(TMPCAPR,PRRCA.K,0,3,.5)  
1161 T TMPCAPR=0/.6/1/1.3/1.55/1.7/1.8  
1170 A PRRCA.K=PRCAP.K/APRIS.K  
1180 A MPCAPA.K=TABHL(TMPCAP,AVICAG.K,0,2,.25)  
1181 T TMPCAP=2.6/2.4/2/1.45/1/.8/.7/.64/.6  
1190 A AVICAG.K=MECA\*AVCAG.K+(1-MECA)\*(OUTCAP.K/DCAPG.K)  
1191 C MECA=.5  
1200 A AVCAG.K=TCAPG.K/DCAPG.K  
1210 A DCAPG.K=DDCAPG.K+ECAPG.K  
1220 A TCAPG.K=OUTCAP.K+ICAPG.K-ECAPG.K  
1221  
1222  
1223  
1224 -----  
1225  
1226 3.3 INTERMEDIATE GOODS SECTOR  
1227 -----  
1228  
1229  
1231  
1240 A OUTI.K=PCI.K\*UFID.K  
1250 A UFID.K=TABHL(TUFID,AAVI.K,.75,2,.25)  
1251 T TUFID=1/1/.85/.7/.63/.6  
1260 A AAVI.K=SMOOTH(AVIG.K,TAIVI)  
1261 C TAAVI=1  
1262 N AAVI=1  
1270 A PCI.K=PPI.K\*PRI.K  
1280 A PRI.K=TABHL(TPRI,EXII.K,0,1,.2)  
1281 T TPRI=0/.45/.70/.85/.95/1  
1290 A EXII.K=EXI.K/PPI.K  
1300 A EXI.K=SMOOTH(OUTI.K,TAEI)  
1301 C TAEI=10  
1302 N EXI=EXIN  
1303 C EXIN=4800  
1310 A PPI.K=FPI.K\*PCIS.K  
1320 A FPI.K=(ADPI.K)/(ADPCON.K+ADPI.K+ADPCAP.K+ADPE.K)  
1330 A ADPI.K=SMOOTH(DPI.K,TADPI)  
1331 C TADPI=20  
1332 N ADPI=6000  
1340 A DPI.K=PPI.K\*MPIA.K\*MPIPR.K\*MPICU.K  
1350 A MPICU.K=TABHL(TMPICU,UFID.K,0,1,.2)  
1351 T TMPICU=0/.4/.7/.85/.95/1

1360 A MPIP.R.K=TABHL(TMPIP,PRRI.K,0,3,.5)  
1361 T TMPIP=0/.6/1/1.3/1.55/1.7/1.8  
1370 A PRRI.K=PRI.K/APRIS.K  
1380 A MPIA.K=TABHL(TMPI,AVIIG.K,0,2,.25)  
1381 T TMPI=2.6/2.4/2/1.45/1/.8/.7/.64/.60  
1390 A AVIIG.K=MEI\*AVIG.K+(1-MEI)\*(OUTI.K/DIG.K)  
1391 C MEI=.5  
1400 A AVIG.K=TIG.K/DIG.K  
1410 A DIG.K=DDIG.K+EIG.K  
1420 A TIG.K=OUTI.K+IIG.K-EIG.K  
1430 A DDIG.K=DICON.K+DICAP.K  
1440 A DICON.K=PCCON.K\*IVARCO.K\*UFCOD.K  
1450 A DICAP.K=PCCAP.K\*IVARCA\*UFCAD.K  
1451  
1452  
1453  
1454 \*\*\*\*\*  
1455  
1456 4. ALLOCAITON OF INCOME  
1457  
1458 \*\*\*\*\*  
1459  
1461  
1470 L CAP.K=CAP.J+DT\*(CAPF.JK-CAPD.JK)  
1471 N CAP=CAPN  
1472 C CAPN=499300  
1480 R CAPD.KL=CAP.K/LCAP  
1481 C LCAP=25  
1490 R CAPF.KL=DELAY1((TCAPG.K+ICONS.K),DCF)  
1491 C DCF=2  
1500 A DDCAPG.K=FICE\*DDCAPI.K  
1501 C FICE=.317  
1510 A ICONS.K=DDCONS.K\*MICONA.K  
1520 A MICONA.K=TABHL(TMICON,AVCOG.K,0,1,.25)  
1521 T TMICON=0/.25/.5/.75/1  
1530 A DDCONS.K=(1-FICE)\*DDCAPI.K\*MDCACG.K  
1540 A MDCACG.K=TABHL(TMDCACG,AVCAG.K,0,1,.2)  
1541 T TMDCACG=.2/.3/.45/.7/.9/1  
1550 A DDCAPI.K=DFI.K\*(POP.K/1000000)\*AIPC.K  
1560 A DDF.K=DDF.K\*(POP.K/1000000)\*AIPC.K  
1570 A DDCONG.K=DFC.K\*(POP.K/1000000)\*AIPC.K-PCE.K  
1580 A DFF.K=TABHL(TDFF,AIPC.K,0,100000,10000)  
1581 T TDFF=1/.5/.3/.23/.19/.16/.14/.125/.116/.11/.105  
1590 A DFI.K=TABHL(TDFI,AIPC.K,0,100000,10000)  
1591 T TDFI=0/.10/.16/.20/.225/.24/.248/.253/.257/.259/.26  
1600 A DFC.K=1-DDF.K-DFI.K  
1610 A AIPC.K=((FE.K/TSAIN)+GNP.K)\*1000000/POP.K  
1611 C TSAIN=1  
1620 A GNP.K=NOO.K+OILREV.K  
1630 A NOO.K=VACON.K+OUTI.K+VACAP.K+FOUT.K+PCE.K  
1640 A GNPPC.K=(GNP.K\*1000000)/POP.K  
1641

1642  
1643  
1644 \*\*\*\*\*  
1645  
1646 5. TRADE SECTOR  
1647  
1648 \*\*\*\*\*  
1649  
1651  
1652 -----  
1653  
1654 5.1 IMPORT AND EXPORT OF FOOD  
1655  
1656 -----  
1657  
1658  
1660 L FE.K=FE.J+DT\*(TE.JK-TI.JK)  
1661 N FE=FEN  
1662 C FEN=10000  
1670 R TI.KL=IF.K+IIG.K+ICONG.K+ICAPG.K  
1680 S IFCA.K=IF.K+ICAPG.K  
1690 S IFCAI.K=IF.K+ICAPG.K+IIG.K  
1700 R TE.KL=OILREV.K+NOE.K  
1710 A NOE.K=EF.K+EIG.K+ECONG.K+ECAPG.K  
1720 A IF.K=DIF.K\*MIFFEA.K  
1730 A MIFFEA.K=TABHL(TMIFFE,FAVI.K,0,1,.25)  
1731 T TMIFFE=0/.45/.7/.9/1  
1740 A FAVI.K=FE.K/(NFEC\*ATDI.K)  
1750 A ATDI.K=SMOOTH(TDI.K,TATDI)  
1751 C TATDI=1  
1752 N ATDI=62700  
1753 C NFEC=.25  
1760 A TDI.K=DIF.K+DICO.K+DII.K+DICA.K  
1770 A DIF.K=FIF.K\*FOUT.K  
1780 A FIF.K=TFI.K\*TABXT(TFIF,RDODOF.K,-.5,1.5,.25)+(1-TFI.K)\*TABXT(  
1781 X TFIFT,RDODOF.K,-.5,1.5,.25)  
1782 T TFIF=.01/.015/.04/.25/.5/.75/1.0/1.25/1.5  
1783 T TFIFT=.01/.015/.04/.1/.2/.3/.4/.5/.6  
1790 A TFI.K=CLIP(1,TFIC,1978,TIME.K)  
1791 C TFIC=1  
1800 A RDODOF.K=DODF.K/FOUT.K  
1810 A DODF.K=DDF.K-FOUT.K  
1820 A EF.K=AEF.K\*MEDEF.K  
1830 A MEDEF.K=TABHL(TMEDEF,(DEF.K/AEF.K),0,1.4,.2)  
1831 T TMEDEF=0/.35/.6/.75/.88/1/1.10/1.10  
1840 A AEF.K=SMOOTH(EF.K,TAEF)  
1841 C TAEF=1  
1842 N AEF=7400  
1850 A DEF.K=FEF.K\*FOUT.K\*MEFEA.K  
1860 A FEF.K=TABHL(TFEF,RDODOF.K,-.5,1.5,.5)  
1861 T TFEF=.3/.04/.02/.014/.01  
1870 A MEFEA.K=TABHL(TMEFEA,FAVI.K,0,2.5,.5)  
1871 T TMEFEA=1.5/1.3/1/.8/.65/.6

1872  
1873  
1874  
1875  
1876  
1877  
1878  
1879  
1881

-----  
5.2 IMPORT AND EXPORT OF CONSUMPTION GOODS  
-----

1890 A ICONG.K=DICO.K\*MICOFEA.K  
1900 A MICOFEA.K=TABHL(TMIFEAF,FAVI.K,0,2.5,.5)  
1901 T TMIFEAF=0/.6/1/1.35/1.6/1.75  
1910 A DICO.K=FICO.K\*OUTCON.K  
1920 A FICO.K=TCOI.K\*TABXT(TFICO,RDODOCO.K,-.5,1,.25)+(1-TCOI.K)\*  
1921 X TABHL(TFICOT,RDODOCO.K,-.5,1,.25)  
1922 T TFICO=.02/.03/.05/.15/.35/.55/.75  
1923 T TFICOT=.02/.03/.05/.1/.15/.20/.25  
1930 A TCOI.K=CLIP(1,TCOIC,1978,TIME.K)  
1931 C TCOIC=1  
1940 A RDODOCO.K=DODCO.K/OUTCON.K  
1950 A DODCO.K=DDCONG.K+DDCONS.K-OUTCON.K  
1960 A ECONG.K=AECO.K\*MEDECO.K  
1970 A MEDECO.K=TABHL(TMEDCO,(DECO.K/AECO.K),0,1.4,.2)  
1971 T TMEDCO=0/.35/.6/.75/.88/1/1.10/1.10  
1980 A AECO.K=SMOOTH(ECONG.K,TAECO)  
1981 C TAECO=1  
1982 N AECO=5000  
1990 A DECO.K=FECO.K\*OUTCON.K\*MEFEA.K  
2000 A FECO.K=TABHL(TFECO,RDODOCO.K,-.5,1,.25)  
2001 T TFECO=.20/.15/.08/.02/.01/.01/.01

2002  
2003  
2004  
2005

-----  
5.3 IMPORT AND EXPORT OF CAPITAL GOODS  
-----

2006  
2007  
2008  
2009  
2011

2020 A ICAPG.K=DICA.K\*MICFEA.K  
2030 A MICFEA.K=TABHL(TMICFE,FAVI.K,0,1,.25)  
2031 T TMICFE=0/.45/.75/.9/1  
2040 A DICA.K=FICA.K\*OUTCAP.K  
2050 A FICA.K=TCAI.K\*TABXT(TFICA,RDODOCA.K,-2,8,2)+(1-TCAI.K)\*  
2051 X TABHL(TFICAT,RDODOCA.K,-2,8,2)  
2052 T TFICA=.02/.1/2/4/6/8  
2053 T TFICAT=.02/.1/1/2/3/4  
2060 A TCAI.K=CLIP(1,TCAIC,1978,TIME.K)  
2061 C TCAIC=1  
2070 A RDODOCA.K=DODCA.K/OUTCAP.K  
2080 A DODCA.K=DDCAPG.K-OUTCAP.K

2090 A ECAPG.K=AECA.K\*MEDECA.K  
2100 A MEDECA.K=TABHL(TMEDCA,(DECA.K/AECA.K),0,1.4,.2)  
2101 T TMEDCA=0/.35/.6/.75/.88/1/1.10/1.10  
2110 A AECA.K=SMOOTH(ECAPG.K,TAECA)  
2111 C TAECA=1  
2112 N AECA=20  
2120 A DECA.K=FECA.K\*OUTCAP.K\*MEFEA.K  
2130 A FECA.K=TABHL(TFECA,RDODOCA.K,-2,8,2)  
2131 T TFECA=1.2/.1/.05/.04/.035/.03

2132  
2133  
2134

-----  
5.4 IMPORT AND EXPORT OF INTERMEDIATE GOODS  
-----

2135  
2136  
2137  
2138  
2139

2141  
2150 A IIG.K=DII.K\*MIIFEA.K  
2160 A MIIFEA.K=TABHL(TMIIFE,FAVI.K,0,1,.25)  
2161 T TMIIFE=0/.45/.75/.9/1  
2170 A DII.K=FII.K\*OUTI.K  
2180 A FII.K=TII.K\*TABXT(TFII,RDODOI.K,-2,8,2)+(1-TII.K)\*TABHL(TFIIT,  
2181 X RDODOI.K,-2,8,2)  
2182 T TFII=.2/.4/2/4/6/8  
2183 T TFIIT=.2/.4/1/2/3/4  
2190 A TII.K=CLIP(1.TIIC,1978,TIME.K)  
2191 C TIIC=1  
2200 A RDODOI.K=DODI.K/OUTI.K  
2210 A DODI.K=DDIG.K-OUTI.K  
2220 A EIG.K=AEI.K\*MEDEI.K  
2230 A MEDEI.K=TABHL(TMEDEI,(DEI.K/AEI.K),0,1.4,.2)  
2231 T TMEDEI=0/.35/.6/.75/.88/1/1.10/1.10  
2240 A AEI.K=SMOOTH(EIG.K,TAEXI)  
2241 C TAEXI=1  
2242 N AEI=1300  
2250 A DEI.K=FEI.K\*OUTI.K\*MEFEA.K  
2260 A FEI.K=TABHL(TFEI,RDODOI.K,-2,8,2)  
2261 T TFEI=1.5/.4/.25/.15/.12/.10

2262  
2263  
2264

\*\*\*\*\*

2265  
2266  
2267  
2268  
2269

6. OIL SECTOR

\*\*\*\*\*

2270  
2271  
2272  
2280 L  
2281 N  
2282 C

OIL.K=OIL.J+DT\*(-OILEX.JK-DOCON.JK)  
OIL=OILN  
OILN=100

2290 R OILEX.KL=CLIP(EDO.K,EO.K,TSEOE,TIME.K)  
2291 C TSEOE=1977  
2300 A EDO.K=TABHL(TEDO,TIME.K,1959,1977,2)  
2301 T TEDO=.327/.4104/.512/.6518/.9008/1.1726/1.5978/2.045/1.7617/2.1  
2310 A EO.K=AEO.K\*MOEDE.K  
2320 A MOEDE.K=TABXT(TMOEDE,(DEO.K/AEO.K),.98,1.06,.01)  
2321 T TMOEDE=.98/.99/1/1.01/1.02/1.03/1.04/1.05/1.06  
2330 A DEO.K=AEO.K\*MEOR.K\*MEOFA.K  
2340 A MEOFA.K=TABHL(TMEOF,FAVI.K,0,2,.25)  
2341 T TMEOF=1.5/1.45/1.35/1.2/1/.85/.75/.72/.7  
2350 A MEOR.K=TABHL(TMEOR,(OIL.K/RRNC.K),0,2,.2)  
2351 T TMEOR=0/.1/.3/.6/.85/1/1.04/1.07/1.09/1.10/1.10  
2360 A RRNC.K=(DOCON.JK+AEO.K)\*NRC  
2370 A AEO.K=SMOOTH(OILEX.JK,TAEO)  
2371 C TAEO=2  
2372 N AEO=.32  
2380 R DOCON.KL=DDE.K\*MDOCA.K\*(NOO.K/PNOO.K)  
2390 A MDOCA.K=TABHL(TMDOCA,OAVI.K,0,1,.2)  
2391 T TMDOCA=0/.15/.4/.7/.9/1  
2400 A OILREV.K=OILEX.JK\*OILP.K\*1000  
2410 A OILP.K=TABHL(TOILP,TIME.K,1958,1976,2)\*(1+STEP(STOP,TSTOP))+  
2411 X CLIP(0,TGIPO,1980,TIME.K)(465)(EXP(RGPO\*(TIME.K-1980))-1)  
2412 C STOP=0  
2413 C TSTOP=1985  
2414 C RGPO=.05  
2415 C TGIPO=0  
2416 T TOILP=101/95.0/88.0/129.4/86.77/85.46/79.42/107.99/462.8/465  
2417  
2418  
2419  
2421 \*\*\*\*\*  
2422  
2423 7. POPULATION SECTOR  
2424  
2425 \*\*\*\*\*  
2426  
2427  
2430 A POP.K=AP.K+SAC.K+PSC.K  
2440 L AP.K=AP.J+DT\*(SAA.JK-DRAP.JK)  
2441 N AP=APN  
2442 C APN=11999000  
2450 L SAC.K=SAC.J+DT\*(PSSA.JK-SAA.JK-DRSAC.JK)  
2451 N SAC=SACN  
2452 C SACN=3957000  
2460 L PSC.K=PSC.J+DT\*(BR.JK-PSSA.JK-DRPSC.JK)  
2461 N PSC=PSCN  
2462 C PSCN=5221000



2470 R BR.KL=AP.K\*NBR\*MBRF.K\*MBRI.K\*MBRE.K  
2471 C NBR=0.10  
2480 A MBRF.K=TABHL(TMBRF,(FPC.K/NFPC),0,2.5,.5)  
2481 T TMBRF=0/.7/1/1.15/1.22/1.25  
2482 C NFPC=8582  
2490 A FPC.K=TF.K/(POP.K/1000000)  
2500 A MBRE.K=TABHL(TMBRE,(SYPAP.K/NSYPAP),0,5,1)  
2501 T TMBRE=1.3/1/.85/.75/.68/.65  
2502 C NSYPAP=1.21  
2510 A MBRI.K=TABHL(TMBRI,(IPC.K/NIPC),0,5,1)  
2511 T TMBRI=1.4/1/.75/.6/.54/.5  
2520 A IPC.K=IOUT.K/(POP.K/1000000)  
2521 C NIPC=33758  
2530 R DRPSC.KL=NDRPS\*PSC.K\*MDRF.K\*MDRI.K  
2531 C NDRPS=0.036  
2540 A MDRF.K=TABHL(TMDRF,(FPC.K/NFPC),0,2,.25)  
2541 T TMDRF=30/3/2/1.3/1/.85/.78/.72/.70  
2550 A MDRI.K=TABHL(TMDRI,(IPC.K/NIPC),0,5,1)  
2551 T TMDRI=2/1/.8/.7/.65/.65  
2560 R DRSA.KL=NDRSA\*SAC.K\*MDRF.K\*MDRI.K  
2561 C NDRSA=0.0025  
2570 R DRAP.KL=AP.K\*NDRA\*MDRF.K\*MDRI.K  
2571 C NDRA=.0141  
2580 R PSSA.KL=PSC.K/DPSP  
2581 C DPSP=6  
2590 R SAA.KL=SAC.K/DSAP.K  
2600 A DSAP.K=8+(PDSAP.K-8)\*(NST.K/SAC.K)  
2610 A PDSAP.K=TABLE(TPDSAP,DE.K,0,16,8)  
2611 T TPDSAP=8/8/16  
2620 A L.K=AP.K\*RLAP  
2621 C RLAP=.56  
2630 S CBR.K=(BR.JK/AP.K)\*1000  
2640 S CDRAP.K=(DRAP.JK/AP.K)\*1000  
2650 S CDRSAC.K=(DRSAC.JK/SAC.K)\*1000  
2660 S CDRPSA.K=(DRPSC.JK/PSC.K)\*1000  
2670 S CD RTP.K=(DR.K/POP.K)\*1000  
2680 A DR.K=DRPSC.JK+DRSAC.JK+DRAP.JK  
2681  
2682  
2683  
2684 \*\*\*\*\*  
2685  
2686 8. EDUCATION SECTOR  
2687  
2688 \*\*\*\*\*  
2689  
2691  
2700 L E.K=E.J+DT\*(RIE.JK-RE.JK)  
2701 N E=EN  
2702 C EN=10000  
2710 R RE.KL=E.K\*NDRA\*MDRF.K\*MDRI.K  
2720 R RIE.KL=(TR.JK\*DE.K\*(1-DROP.K))/1000

2730 A  $DROP.K = CDRE * DROPE.K + (1 - CDRE) * DROPI.K$   
2731 C  $CDRE = .5$   
2740 A  $DROPE.K = TABHL(TDROPE, SYPAP.K, 0, 10, 2)$   
2741 T  $TDROPE = .6 / .45 / .32 / .22 / .15 / .1$   
2750 A  $SYPAP.K = (E.K * 1000) / AP.K$   
2760 A  $DROPI.K = TABHL(TDROPI, GNPPC.K, 0, 150000, 25000)$   
2761 T  $TDROPI = .7 / .55 / .42 / .32 / .25 / .19 / .15$   
2770 A  $DE.K = CDEE * DEE.K + (1 - CDEE) * DEDI.K$   
2771 C  $CDEE = .5$   
2780 A  $DEE.K = TABHL(TDEE, SYPAP.K, 0, 10, 1)$   
2781 T  $TDEE = 0 / 6 / 9 / 10.5 / 11.4 / 12.2 / 12.8 / 13.3 / 13.7 / 13.9 / 14$   
2790 A  $DEDI.K = TABHL(TDEI, GNPPC.K, 0, 140000, 10000)$   
2791 T  $TDEI = 0 / 5 / 7 / 8.8 / 10 / 11 / 11.8 / 12.4 / 12.9 / 13.2 / 13.5 / 13.7 / 13.85 / 13.95 / 14$   
2800 R  $TR.KL = DELAYP(AR.JK, DE.K, NST.K)$   
2801 N  $AR = 270000$   
2810 R  $AR.KL = ((ECAP.K * ESDA.K - NST.K) / TANS) + ATR.K$   
2811 C  $TANS = .5$   
2820 A  $ATR.K = SMOOTH(TR.JK, TATR)$   
2821 C  $TATR = .25$   
2830 A  $ESDA.K = TABHL(ESDA, (SDE.K / ECAP.K), 0, 1, .2)$   
2831 T  $ESDA = 0 / .4 / .65 / .85 / .95 / 1$   
2840 A  $ECAP.K = (PCE.K * 1000000) / PCEC.K$   
2850 A  $PCEC.K = PCECD.K * (NOOPC.K / NOOPCN)$   
2851 C  $NOOPCN = 40891$   
2860 A  $PCECD.K = TABLE(TPCE, DE.K, 0, 16, 4)$   
2861 T  $TPCE = 9000 / 9500 / 10500 / 12500 / 16000$   
2870 A  $NOOPC.K = (NOO.K * 1000000) / POP.K$   
2880 A  $PCE.K = FPE.K * PCIS.K$   
2890 A  $FPE.K = ADPE.K / (ADPCON.K + ADPI.K + ADPCAP.K + ADPE.K)$   
2900 A  $ADPE.K = SMOOTH(DPE.K, TADPE)$   
2901 C  $TADPE = 15$   
2902 N  $ADPE = ADPEN$   
2903 C  $ADPEN = 12000$   
2910 A  $DPE.K = MPEA.K * PCE.K$   
2920 A  $MPEA.K = TEEP.K * TABLE(TMPEA, AVEC.K, 0, 2, .25) + (1 - TEEP.K) *$   
2921 X  $TABLE(TMPEAT, AVEC.K, 0, 2, .25)$   
2922 T  $TMPEA = 1.55 / 1.5 / 1.4 / 1.25 / 1 / .8 / .7 / .64 / .6$   
2923 T  $TMPEAT = 2.6 / 2.4 / 2 / 1.45 / 1 / .8 / .7 / .64 / .6$   
2930 A  $TEEP.K = CLIP(1, TEEPC, 1978, TIME.K)$   
2931 C  $TEEPC = 1$   
2940 A  $AVEC.K = ECAP.K / SDE.K$   
2950 A  $SDE.K = DER.K * (SAC.K) * (DE.K / DSAP.K)$   
2960 A  $DER.K = CDERE * DERE.K + (1 - CDERE) * (DERI.K)$   
2961 C  $CDERE = .5$   
2970 A  $DERE.K = TABHL(TDERE, SYPAP.K, 0, 6, .5)$   
2971 T  $TDERE = 0 / .45 / .6 / .7 / .8 / .85 / .9 / .925 / .95 / .965 / .98 / .99 / 1$   
2980 A  $DERI.K = TABHL(TDERI, GNPPC.K, 0, 150000, 10000)$   
2981 T  $TDERI = 0 / .45 / .6 / .69 / .75 / .8 / .84 / .88 / .91 / .94 / .955 / .97 / .98 / .99 / .995 / 1$   
2982  
2983

2984  
2985 \*\*\*\*\*  
2986  
2987 9. TECHNOLOGY TRANSFER  
2988  
2989 \*\*\*\*\*  
2991  
2992  
2993 -----  
2994  
2995 9.1 TECHNOLOGY TRANSFER IN INDUSTRY  
2996  
2997 -----  
2998  
2999  
3001  
3010 L TIS.K=TIS.J+DT\*RTTI.JK  
3011 N TIS=TISN  
3012 C TISN=1  
3020 R RTTI.KL=((TISA.K-TIS.K)/NTIT.K)\*MTTFT.K\*MTTEI.K  
3030 A TISA.K=TISAN\*EXP(RTPI\*(TIME.K-1959))  
3031 C TISAN=5.176  
3032 C RTPI=.0137  
3040 A NTIT.K=LOGN(TERIS.K)/(RTPI\*CTPT)  
3041 C CTPT=1.5  
3050 A TERIS.K=TISA.K/TIS.K  
3060 A MTTFT.K=TABHL(TMTTFT,(FTR.K/FTRN),0,3,.5)  
3061 T TMTTFT=.25/.65/1/1.2/1.35/1.45/1.5  
3062 C FTRN=.12  
3070 A FTR.K=TI.JK/NOO.K  
3080 A MTTEI.K=TABHL(TMTTI,TNTRI.K,0,2.5,.5)  
3081 T TMTTI=0/.6/1/1.3/1.5/1.6  
3090 A TNTRI.K=TNI.K/TIS.K  
3100 A TNI.K=TEII.K\*TISA.K  
3110 A TEII.K=TABHL(TTEI,(SYPLI.K/SYPILA.K),0,1,.25)  
3111 T TTEI=0/.32/.6/.82/1  
3120 A SYPLI.K=(1000\*EIS.K)/LIS.K  
3130 A SYPILA.K=12  
3131  
3132  
3133 -----  
3134  
3135 9.2 TECHNOLOGY TRANSFER IN AGRICULTURE  
3136  
3137 -----  
3138  
3139  
3140 L TAS.K=TAS.J+DT\*RTTA.JK  
3141 N TAS=TASN  
3142 C TASN=1  
3150 R RTTA.KL=((TASA.K-TAS.K)/NTAT.K)\*MTTFTA.K\*MTTEA.K

3160 A TASA.K=TASAN\*EXP(RTPA\*(TIME.K-1959))  
3161 C TASAN=4  
3162 C RTPA=.01  
3170 A NTAT.K=LOGN(TERAS.K)/(RTPA\*CTPT)  
3180 A TERAS.K=TASA.K/TAS.K  
3190 A MTTFTA.K=TABHL(TMTTFA,(FTR.K/FTRN),0,3,.5)  
3191 T TMTTFA=.25/.65/1/1.2/1.35/1.45/1.50  
3200 A MTTEA.K=TABHL(TMTTA,TNTRA.K,0,2.5,.5)  
3201 T TMTTA=0/.6/1/1.3/1.5/1.6  
3210 A TNTRA.K=TNA.K/TAS.K  
3220 A TNA.K=TEIA.K\*TASA.K  
3230 A TEIA.K=TABHL(TTEIA,(SYPLA.K/SYPLAA.K),0,1,.25)  
3231 T TTEIA=0/.32/.6/.82/1  
3240 A SYPLA.K=(EAS.K\*1000)/LAS.K  
3250 A SYPLAA.K=8  
3251  
3252  
3253  
3254 PRINT GNP,NOO,GNPPC,FPC,FAVI,TF,FOUT,DOCON  
3255 TIG,OUTI,TCAPG,OUTCAP,TCONG,OUTCON,OIL,OILEX  
3256 PRINT SYPAP,SYPLI,TE,NOE,TI,IF,ICAPG,IIG,ICONG  
3257 PRINT POP,CDRTP,CBR,CDRSAC,CDRAP,CDRPSA,UFCOIA,TIS  
3258 PRINT FA,AVCOG,AVCAG,AVIG,UFCO,MPCOCU,PRI,PRCAP  
3259  
3261 PLOT GNP=1,NOO=2(0,1E7)/GNPPC=3(0,1.6E5)/FPC=4(0,1.6E4)/FAVI=5(0,2)  
3262 PLOT TF=1,FOUT=2(0,8E5)/TIG=3,OUTI=4(0,2.4E6)/TCAPG=5,OUTCAP=6(0,4.8E5)  
3263 PLOT TCONG=1,OUTCON=2(0,1E7)/OIL=3(0,100)/OILEX=4,DOCON=5(0,6)  
3264 PLOT TI=1,IF=2,IFCA=3,IFCAI=4(0,2E6)  
3265 PLOT POP=1(0,8E7)/SYPAP=2(0,8)/TE=3,NOE=4(0,2E6)/NOE=5(0,5E5)/OILP=6  
3266 X (0,3200)  
3267 PLOT FA=1,AVCOG=2,AVCAG=3,AVIG=4(0,2)  
3268 PLOT UFCO=1,PRI=2,PRCAP=3,MPCOCU=4,MPIPR=5,MPCAPR=6(0,2)  
3269 PLOT PPCIS=1,PCIS=2(0,4E7)/PFOUT=3,FOUT=4(0,16E5)/CAPIS=5(0,3.2E7)/  
3271 X LIS=7(0,3.2E7)/TIS=8(0,10)  
3280 A PLTPER.K=STEP(PLTPERC,1960)  
3281 C PLTPERC=1  
3290 A PRTPER.K=STEP(PRTPERC,1960)  
3291 C PRTPERC=0  
3292 SPEC LENGTH=2010,DT=.2  
3293 N TIME=1959  
3294 NOTE BASIC RUN  
3295 RUN RUN B

3296 NOTE BASIC RUN WITH 50% HIGHER INITIAL OIL RESERVES  
3297 C OILN=150  
3298 PLOT GNP=1,NOO=2(0,1E7)/GNPPC=3(0,1.6E5)/FPC=4(0,1.6E4)/FAVI=5(0,2)  
3299 PLOT TF=1,FOUT=2(0,8E5)/TIG=3,OUTI=4(0,2.4E6)/TCAPG=5,OUTCAP=6(0,4.8E5)  
3301 PLOT TCONG=1,OUTCON=2(0,1E7)/OIL=3(0,150)/OILEX=4,DOCON=5(0,9)  
3302 PLOT TI=1,IF=2,IFCA=3,IFCAI=4(0,2E6)  
3303 PLOT POP=1(0,8E7)/SYPAP=2(0,8)/TE=3,NOE=4(0,2E6)/NOE=5(0,5E5)/OILP=6  
3304 X (0,3200)  
3305 PLOT FA=1,AVCOG=2,AVCAG=3,AVIG=4(0,2)  
3306 PLOT UFCO=1,PRI=2,PRCAP=3,MPCOCU=4,MPIPR=5,MPCAPR=6(0,2)  
3307 PLOT PPCIS=1,PCIS=2(0,4E7)/PFOUT=3,FOUT=4(0,16E5)/CAPIS=5(0,3.2E7)/  
3308 X LIS=7(0,3.2E7)/TIS=8(0,10)  
3309 RUN RUN B.1  
3311 NOTE BASIC RUN PLUS 5% ANNUAL RISE IN OIL PRICE AFTER 1980  
3312 C TGIPO=1  
3313 PLOT GNP=1,NOO=2(0,1E7)/GNPPC=3(0,1.6E5)/FPC=4(0,1.6E4)/FAVI=5(0,2)  
3314 PLOT TF=1,FOUT=2(0,8E5)/TIG=3,OUTI=4(0,2.4E6)/TCAPG=5,OUTCAP=6(0,4.8E5)  
3315 PLOT TCONG=1,OUTCON=2(0,1E7)/OIL=3(0,100)/OILEX=4,DOCON=5(0,6)  
3316 PLOT TI=1,IF=2,IFCA=3,IFCAI=4(0,2E6)  
3317 PLOT POP=1(0,8E7)/SYPAP=2(0,8)/TE=3,NOE=4(0,2E6)/NOE=5(0,5E5)/OILP=6  
3318 X (0,3200)  
3319 PLOT FA=1,AVCOG=2,AVCAG=3,AVIG=4(0,2)  
3321 PLOT UFCO=1,PRI=2,PRCAP=3,MPCOCU=4,MPIPR=5,MPCAPR=6(0,2)  
3322 PLOT PPCIS=1,PCIS=2(0,4E7)/PFOUT=3,FOUT=4(0,16E5)/CAPIS=5(0,3.2E7)/  
3323 X LIS=7(0,3.2E7)/TIS=8(0,10)  
3324 RUN RUN B.2  
3325 NOTE BASIC RUN PLUS 100% RISE IN OIL PRICE IN 1985  
3326 C STOP=1  
3327 RUN RUN B.3  
3328 NOTE POLICY RUN 1: RESTRICTION ON CONSUMPTION GOODS IMPORTS  
3329 C TCOIC=0  
3331 RUN RUN P.1  
3332 NOTE POLICY RUN 2: RESTRICTION ON FOOD IMPORTS  
3333 C TFIC=0  
3334 RUN RUN P.2  
3335 NOTE POLICY RUN 3: RESTRICTION ON GROWTH OF OIL EXPORTS  
3336 TP TMOEDE=.98/.99/1/1.01/1.02/1.02/1.02/1.02/1.02/1.02  
3337 RUN RUN P.3  
3338 NOTE POLICY RUN 4: RESTRICTIONS ON GROWTH OF OIL EXPORTS, FOOD AND  
3339 NOTE CONSUMPTION GOODS IMPORTS  
3341 CP TCOIC=0  
3342 CP TFIC=0  
3343 RUN RUN P.4  
3344 NOTE POLICY RUN 4 PLUS 5% ANNUAL RISE IN OIL PRICE AFTER 1980  
3345 CP TGIPO=1  
3346 RUN RUN P.4.1  
3347 NOTE THE SAME AS RUN P.4.1 BUT WITH DOUBLED SCALES FOR PLOTS  
3348 PLOT GNP=1,NOO=2(0,2E7)/GNPPC=3(0,3.2E5)  
3349 PLOT TIG=3,OUTI=4(0,4.8E6)/TCAPG=5,OUTCAP=6(0,9.6E5)  
3351 RUN RUN P.4.1.1  
READY



APPENDIX C: INDUSTRIAL CLASSIFICATION

This appendix presents a classification of manufacturing into the three groups used in this thesis - consumption goods, capital goods, and intermediate goods. This classification was used to prepare and aggregate data presented in Chapter 1. The following list of industries is according to International Standard Industrial Classification ISIC Coding (Published in Statistical Papers Series M, No. 2, Rev. 2, United Nations, New York, 1968) which is used by the Bureau of Statistics in the ministry of industry and mine in Iran.

TABLE C.1

CLASSIFICATION OF MINING AND MANUFACTURING INTO  
CONSUMPTION GOODS, INTERMEDIATE GOODS, AND  
CAPITAL GOODS INDUSTRIES

ISIC Code No.	Description	Consump- tion Goods	Inter- mediate Goods	Capital Goods
2	Mining and Quarrying			
21	Coal mining		x	
23	Metal ore mining		x	
29	Other mining		x	
	Manufacturing of Food, Beverage and Tobacco			
311-312	Food manufacturing	x		
313	Beverage industries	x		
314	Tobacco manufacturing	x		
32	Textile, Wearing Apparel and Leather Industries			
321	Manufacturing of textiles	x		
322	Manufacturing of wearing, except footwear		x	
323	Manufacturing of leather and products of leather, leather substitutes and fur, except footwear and wearing apparel		x	
324	Manufacturing of footwear, except vulcanized or molded rubber or plastic footwear			x



ISIC Code No.	Description	Consump- tion Goods	Inter- mediate Goods	Capital Goods
33	Manufacture of Wood and Wood Products, Including Furnitur			
331	Manufacture of wood and wood cork products, excpet furniture - (doors, window and door frames, other wooden building materials and prefabricated wooden parts and structure)		x	
	. Doors, window and door frames, other wooden building materials and prefabricated wooden parts and structure (included in ISIC Co. No. 3311)		x	
332	Manufacture of furniture and fictures, except primarily of metal	x		
34	Manufacture of Paper and Paper Products, Printing & Publishing			
341	Manufacturing of paper and paper products		x	
342	Printing, publishing and allied industries	x		
35	Manufacture of Chemicals and Chemical, Petroleum, Coal, Rubber and Plastic Products			
351	Manufacture of industrial chemicals		x	
352	Manufacture of other chemical products			
3521	- Manufacture of paints, varnishes and lacquers		x	
3522	- Manufacture of drugs and medicines	x		
3523	- Manufacture of soap and cleaning preparations, perfume, cosmetics and other toilet preparations	x		
3529	- Manufacture of chemical products not elsewhere classified			x

ISIC Code No.	Description	Consump- tion Goods	Inter- mediate Goods	Capital Goods
353	Petroleum refineries		x	
354	Manufacture of miscellaneous products of petroleum and coal		x	
355	Manufacture of rubber products		x	
356	Manufacture of plastic products not elsewhere classified		x	
36	Manufacture of Non-Metallic Mineral Products, Except Products of Petroleum and Coal			
361	Manufacture of pottery, china and earthenware			
	- China household goods	x		
	- China construction materials (plumbing fixtures, bathroom accessories, etc.)		x	
362	Manufacture of glass and glass products		x	
369	Manufacture of other non-metallic mineral products			
3691	- Manufacture of structural clay products		x	
3692	- Manufacture of cements, lime and plaster		x	
3699	- Manufacture of non-metallic mineral products not elsewhere classified		x	
37	Basic Metal Industries			
371	Iron and steel basic industries		x	
372	Non-ferrous metal basic industries		x	
38	Manufacture of Fabricated Metal Products, Machinery and Equipment			
381	Manufacture of fabricated metal products, except machinery and equipment			
3811	- Manufacture of cutlery, hand tools and general hardware			x
3812	- Manufacture of furniture and fixture, primarily of metal	x		

ISIC Code No.	Description	Consump- tion Goods	Inter- mediate Goods	Capital Goods
3813	- Manufacture of structural metal products		x	
3819	- Manufacture of fabricated metal products except machinery and equipment not elsewhere classified	x		
382	Manufacture of machinery except electrical			
3821	- Manufacture of engines and turbines		x	
3822	- Manufacture of agricultural machinery and equipment			x
3823	- Manufacture of metal and wood working machinery			x
3824	- Manufacture of special industrial machinery and equipment except metal and wood working machinery			x
3826	- Manufacture of office, computing and accounting machinery			x
3829	- Machinery and equipment except electrical not elsewhere classified			x
383	Manufacture of:			
3831	- Manufacture of electrical machinery, apparatus, appliances and supplies			x
3832	- Manufacture of radio, television and communication equipment and apparatus	x		
	.manufacture of modern broadcasting equipment			x
3833	- Manufacture of electrical appliances and housewares	x		
3839	- Manufacture of electrical apparatus and supplies not elsewhere classified		x	

ISIC Code No.	Description	Consump- tion Goods	Inter- mediate Goods	Capital Goods
384	Manufacture of transport equipment			
3841	- Ship building and repairing			x
3842	- Manufacture of railroad equipment			x
3843	- Manufacture of motot vehicles			
	.Passenger cars	x( $\frac{1}{2}$ )		x( $\frac{1}{2}$ )
	.Trucks, busses, and others			x
3844	- Manufacture of motorcycles and bicycles	x( $\frac{1}{2}$ )		x( $\frac{1}{2}$ )
3845	- Manufacture of aircraft			x
3849	- Manufacture of transport equipment not elsewhere classified			x
385	Manufacture of professional and scientific, and measuring and controlling equipment not elsewhere classified, and photographic and optical goods			
3851	- Manufacture of professional and scientific, and measuring and controlling equipment, not elsewhere classified			x
3852	- Manufacture of photographic and optical goods	x		
3853	- Manufacture of watches and clocks	x		
39	Other Manufacturing Industries:			
3901	- Manufacturing of jewelry and related articles	x		
3902	- Manufacture of musical instruments	x		
3903	- Manufacture of sporting and athletic goods	x		
3904	- Manufacture of industries not elsewhere classified	x		

REFERENCES

- Alfeld and Graham (1976) Introduction to Urban Dynamics, Wright-Allen Press, Inc., 238 Main Street, Cambridge, Massachusetts 02142, 1968.
- Aminzadeh (1976) Aminzadeh, F., "Human Resources Development: Problems and Prospects," in Jane W. Jacqz (ed.), Iran: Past, Present and the Future, Aspen Institute for Humanistic Studies, 717 Fifth Avenue, New York, N.Y. 10022.
- Amuzegar and Fekrat (1971) Amuzegar, Jahangir and Fekrat, M. Ali, Iran: Economic Development Under Dualistic Conditions, The Univeristy of Chicago Press, 1971.
- Arevik (1976) Arevik, Oddvar, The Agricultural Development of Iran, Praeger Special Studies in International Economics and Development. New York and London, Praeger, 1976.
- Bank Markazi Iran (1968) Bank Markazi Iran, Economic Research Department, National Income of Iran, 1959-65, Tehran, 1968.
- Bank Markazi Iran (1969) Bank Markazi Iran, Economic Research Department, National Income of Iran, 1962-67, Tehran, 1969.
- Bhagwati and Srinivasan (1975) Bhagwati, Jagdish N. and Srinivasan, T.N., Foreign Trade Regimes and Economic Development: India, Columbia University Press, 1975.
- Bharier (1971) Baharier, Julian, Capital Formation in Iran 1900-1965, Ph. D. Thesis in Economics, University of London, 1969.
- BMAR Bank Markazi Iran, Bank Markazi Iran, Annual Report and Balance Sheet, Tehran, Annually from 1961.

- Bowman (1966) Bowman, M.J., "The Human Investment Revolution in Economic Thought," Sociology of Education, Vol. 39 (1966), pp. 111-138. Also published in M. Blaug (ed.), Economics of Education 1, 1971, Penguin Books Ltd., England.
- Chenery and Syrquin (1975) Hollis Chenery and Moises Syrquin, Patterns of Development, 1950-1970, Oxford University Press, 1975.
- DeGolyer and MacNaughton (1976) DeGolyer and MacNaughton, Twentieth Century Petroleum Statistics, One Energy Square, Dallas, Texas 75206, 1976.
- Denison (1962) Denison, Edward F., The Sources of Economic Growth in the United States and Alternatives Before Us, Committee for Economic Development, Supplementary Paper No. 13, New York, 1962.
- Denison (1967) Denison, Edward F., Why Growth Rates Differ, Postwar Experience in Nine Western Countries, The Brookings Institution, 1975 Massachusetts Avenue, N.W., Washington, D.C., September, 1967.
- Forrester (1961) Forrester, Jay, Industrial Dynamics, The MIT Press, 1961.
- Forrester (1968) Forrester, Jay, Principles of Systems, Wright Allen Press, Inc., 238 Main Street, Cambridge, Massachusetts 02142, 1968.
- Goodman (1974) Goodman, Michael R., Study Notes in System Dynamics, Wright-Allen Press, Inc. 238 Main Street, Cambridge, Massachusetts 02142, 1974.
- Hameed and Bennett (1975) Hameed, Kamal A. and Bennett, Margaret N., "Iran's Future Economy," in The Middle East Journal, Autumn, 1975, pp. 418-432.
- Harbison and Mayers (1964) Harbison, Frederick H. and Mayers, Charles A., Education, Manpower, and Economic Growth, McGraw-Hill Book Company, 1964.

- Henderson and Quandt (1958) Henderson, James M. and Quandt, Richard E., Microeconomic Theory, McGraw Hill Book Company, New York, 1958 and 1971.
- Hayashi (1971) Hayashi, Kirk, "The Technology Change in Japan, 1910-1967," in George W. Wilson (ed.), Technological Development and Economic Growth, School of Business, Division of Research, Indiana University, Bloomington, Indiana 47401, 1971, pp. 57-97.
- Jaszi, Wasson, and Grose (1962) Jaszi, G., Wasson, R., and Grose, L., "Expansion of Fixed Business Capital in the United States, Survey of Current Business, Vol. 42 (1962), pp. 9-18.
- Kmenta (1967) Kmenta, Jan, "Economic Theory and Transfer of Technology," in Daniel L. Spencer and Alexander Woroniak (eds.), The Transfer of Technology to Developing Countries, Frederick A. Praeger Publishers, 1967, pp. 39-56.
- Kuznets (1966) Kuznets, Simon, Modern Economic Growth, Rate, Structure, and Spread, Yale University Press, 1966 and 1976.
- Lange (1938) Lange, V., "On the Economic theory of Socialism," in B. Lippincott (ed.); On the Economic Theory of Socialism, Minneapolis, 1938 and 1948.
- Mashayekhi (1977) Mashayekhi, Ali N., "Technological Progress in Iran During 1959-1976," System Dynamics Group Working Paper D-2884, System Dynamics Group, E40-253, Massachusetts Institute of Technology, Cambridge, Massachusetts, 02139.
- Ministry of Industry and Mines Ministry of Industry and Mines, General Department of Statistics and Research, Statistics on Large Industrial Establishments of Iran, Various Issues.
- Nelson (1964) Nelson, R.R., "Aggregate Production Functions and Medium-Range Growth Projection," American Economic Review, LIV, September, 1964.

- OPEC Annual Review and Record (1976) OPEC, Annual Review and Record, 1976, Ohere Donaustrasse 93, 1020, Vienna, Austria.
- Pesaran (1976) Psearan, M.H., "Income Distribution and its Major Determinants in Iran," in Jane W. Jacqz (ed.), Iran: Past, Present and Future, Aspen Institute for Humanistic Studies, 717 Fifth Avenue, New York, N.Y., 10022, 1976.
- Plan and Budget Organization Plan and Budget Organization, Statistical Center, Nataieje Amargirie Niroie Ensani 1351, (in Farsi), Mordad 1353, Tehran.
- Plan and Budget Organization Plan and Budget Organization, Statistical Center, Iran Statistical Yearbook, Tehran, Various Issues.
- Pugh (1976) Pugh III, Alexander, DYNAMO User's Manual, The MIT Press, Cambridge, Massachusetts, 1976.
- Sen (1974) Sen, Amartya (ed.), Growth Economics, Selected Reading, Penguin Books, Ltd., England, 1974.
- Solow (1957) Solow, R.M., "Technology Change and the Aggregate Production Function," Review of Economics and Statistics, Vol. 39, 1957, pp. 312-320.
- Spencer (1970) Spencer, Daniel L., Technology Gap in Perspective; A Strategy of International Technology Transfer, Spartan Books, New York, 1970.
- SRU March 1976 Plan and Budget Organization, Planning Division, Statistical Research Unit (SRU), Economic Statistics and Trends of Iran, Second Edition, Tehran, March, 1976.
- Stiglitz and Uzaw (1969) Stiglitz, Joseph E. and Uzaw, Hirufumi (ed.) Readings in the Modern Theory of Economic Growth, The MIT Press, 1969.
- United Nations (1973) United Nations, Statistical Yearbook, 1973, United Nations, New York.
- United Nations (1975) United Nations, Yearbook of National Account fileistics, 1975, United Nations, New York.



U.S. Department of  
Commerce (1975)

U.S. Department of Commerce, Bureau of the  
Census, Historical Statistics of the United  
States, 1975.

U.S. Department of  
Commerce (1976)

U.S. Department of Commerce, Bureau of the  
Census, Statistical Abstract of the United  
States, 1976.

WAES (1977)

Report of the Workshop on Alternative Energy  
Strategies, Energy: Global Prospects,  
1985-2000, McGraw-Hill Book Company, New  
York, 1977.