

# The Design of Intelligent Cookware

by

**Mansim Connie Cheng**

Submitted to the  
Department of Electrical Engineering and Computer Science  
in partial fulfillment of the requirements for the degrees of  
Bachelor of Science in Computer Science and Engineering and  
Master of Engineering in Electrical Engineering and Computer Science  
at the Massachusetts Institute of Technology

August 25, 2003

© Mansim Connie Cheng 2003.  
All rights reserved.

The author hereby grants to M.I.T. permission to reproduce and  
distribute publicly paper and electronic copies of this thesis  
and to grant others the right to do so.

Author

---

---

Department of Electrical Engineering and Computer Science  
August 25, 2003

Certified by

---

---

Ted J. Selker  
Media Laboratory  
Thesis Advisor

Accepted by

---

---

Arthur C. Smith  
Chairman, Department Committee on Graduate Theses

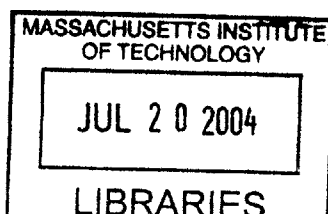

**BARKER**



# **The Design of Intelligent Cookware**

by

**Mansim Connie Cheng**

Submitted to the

Department of Electrical Engineering and Computer Science

in partial fulfillment of the requirements for the degrees of

Bachelor of Science in Computer Science and Engineering and

Master of Engineering in Electrical Engineering and Computer Science

August 29, 2003

## **ABSTRACT**

This thesis investigates the opportunity of teaching people how to cook by analyzing the ingredients' chemical content as they are using them, and the consequent creation of a specific class of context-aware cookware that aids its users.

An inquisition on the chemical content of different food and the appropriate electronics for measuring it was done. An instrument, with embedded sensors and intelligence and in the form of a spatula, was created base on the result of the research, and tested to be able to measure salinity, acidity, temperature, and consistency. This tool was used to demonstrate that several ingredients could be measured easily, and recipes as varied as pickles and pancakes could be improved. The work demonstrates the possibility of having intelligence in the kitchen, and examines the pedagogical value of intelligent tools when they are capable of collaborating with and guiding its user. The research also inquires into the field of ubiquitous computing, in which sensors are placed in ordinary objects, and to assess its impact in a domestic environment.

Thesis Supervisor: Professor Ted J. Selker  
MIT Media Laboratory



## **ACKNOWLEDGEMENTS**

First of all, I would like to thank my advisor Ted Selker, who is well known for his wild ideas, but also for his magical touch in getting almost any gadgets to work. Thank you for your guidance and encouragement, for always pushing me to try things beyond my imagination, and inspiring me to dream big. I would also like to thank Barbara Wheaton, for her unfailing support, both technically and emotionally. Her time-tested wisdom has helped me on this thesis, on cooking and food history, and on life.

I would like to show my gratitude to my fellow graduate collaborators, Leonardo Bonanni, Ernesto Arroyo, Ken Giesecke, David Merrill, Taly Sharon, and Winslow Bureson, for generously sharing their time and technical expertise with me at various stages of the project. Without their help, the project would not be what it is today. I would also like to credit my undergraduate researcher, Brandon Kam, for his hard work on designing and implementing the wireless module, and improving many parts of the original hardware.

Thanks to Heidi Polsen and Sarah Dionne, for their steadfast support on the logistics of the project. Their impeccable organizational skills never fail to amaze. I would also like to extend my appreciation to the members of Context Aware Computing, many of which have lent a sympathetic ear when progress was not well, and had a strong sense of humor to cheer up a lot of otherwise long, dry workdays.

I am much in debt to my parents, for their unconditional encouragement and support and their sacrifices to provide the best education to their children; to Bakfun and Meikee Wong, who are like my parents in Boston; to brothers and sisters in my bible study group and my church, especially Charlotte, Becky, Ada, Benny, and Peggy Chow, whose constant prayer support and “humanitarian aids” that has scattered all around my desk have sustained me through good and bad days. Special thanks to my fiancé, Ernie, for his many Pooh stories, dinner deliveries, late night pickups, weekend soldering sessions, and “last-minute-panic” mood consultations; thank you for walking with me through laughter and tears.

Lastly, I have to give thanks to my Heavenly Father, for giving me all the aforementioned people that I am thankful for, and for turning an ordinary degree fulfillment process into a refreshing and exciting life experience. As said in Psalm 30,

*“You turn my wailing into dancing;  
You removed my sackcloth and clothed me with joy,  
That my heart may sing to You and not be silent.  
O Lord my God, I will give you thanks forever.”*



# TABLE OF CONTENTS

Abstract .....	3
Acknowledgements .....	5
Table of Contents .....	7
Chapter 1. Introduction .....	9
What are Intelligent Tools? .....	10
Chapter 2. Food Chemistry .....	13
Food Content and Measuring Instruments .....	14
Salinity .....	14
Temperature .....	17
Acidity and Consistency .....	19
Food Chemistry – A New View .....	20
Salt .....	21
Acid .....	22
Consistency .....	23
Implications .....	25
Chapter 3. Previous Works .....	27
Computer-Aided Cooking .....	27
Integrated Equipments .....	31
Chapter 4. The Intelligent Spatula .....	35
System Description .....	36
Original Prototype .....	37
Second Prototype .....	40
Casing .....	41
Hardware .....	47
Software .....	49
System Integration .....	51
Demonstrations and Evaluations .....	51
Chapter 5. Conclusion .....	57
Food Chemistry Revisited .....	57
Design Principles for Intelligent Kitchenware .....	58

Implementation Guidelines .....	59
Future Possibilities .....	60
Appendix A. Pancake Recipe .....	63
Appendix B. Acidity and Temperature .....	65
Appendix C. Software Documentation .....	67
Appendix D. Circuit Diagram .....	73
Appendix E. Application Screenshots .....	75
Appendix F. User Study Procedure .....	77
Bibliography .....	74



## CHAPTER 1. **INTRODUCTION**

Tools are a part of everyday life. They are essential to every profession. A carpenter has his hammer; a chef has his knife; a sculptor has his chisel, and a writer has his pen. Tools, together with skill, are the instruments that transform raw materials into a final product.

With a quick look at what is available today, it becomes obvious that the human race has come a long way in improving their tools in their history. With industrialization, mankind discovered a way to drive tools automatically. Nowadays, scores of machines are used in home and industry; those as large as a cargo ship, and as small as an electric hand mixer, they flood the world and do their job with unbeatable efficiency and impeccable accuracy. Machines can often run without human intervention, thanks to the introduction of computer control. The entire machine is connected; once a program is started, a computer feeds instructions to the machine; sensors installed in various parts of the machine can report real-time status to the computer, and adjustments can be made based on the data. These self-tuned machines can continue to run without attention from human.

Strangely, this trend is reversed in the kitchen – few tools are aware of their surroundings and user's actions, and most cannot communicate with each other; a wired kitchen remains a concept in technologists' heads. There may be tools with microelectronics here and sensors there, but the microwave oven never knows what is inside the fridge, and the stove does not realize that it is too hot and the butter is getting burnt. The autonomous tools that people appreciate in other places have no place in the kitchen. They want their food to be prepared in the old-fashioned way, as their grandmothers did. They resist computer intelligence in this sanctified ground; anything more complex than a digital thermometer must not be in the kitchen.

The intention of this thesis is to present a groundbreaking view on food chemistry, to argue how this view can facilitate the creation of smart tools and cookware, and to dismiss the claim that kitchen is not a territory for technological innovations. The argument is substantiated by the Intelligent Spatula project, which is a sensing spatula that can communicate with a computer. It is completed with a software application that analyzes incoming data and guides users through the preparation of several recipes. The construction of the spatula is plain, but with embedded intelligence it enlivens the educational process in cooking with illustrative photos, and audio and visual reminders for various ingredients.

This venture illustrates that with a user- and process-conscious design, simple amendments to everyday utensils can invigorate the cooking experience. Certainly, this kind of work requires a thorough exploration of food chemistry and an inventive way to look at it and to harness its potential. Ordinary kitchenware is transformed into self-aware tools that make suggestions based on the environment and user actions, and yet preserve the human agency of the user. Imagine a baking dish that warns you when your casserole is going to burn, or a ladle or pot that tells you when you forget to add salt to the beef stew. With the panoply of sensing and computing technologies designed to facilitate physical interaction between human and computer, these fiction-like scenarios can eventually become reality.

This document outlines a history of computers in the kitchen, details a new way to look at food's chemical content, describes the work on the Intelligent Spatula project, and discusses its implications and the lessons learned. This research on intelligent cookware leads us to extract general design principles and enabling technologies that will guide future endeavor in this area.

## **WHAT ARE INTELLIGENT TOOLS?**

A tool, as defined by the Merriam-Webster dictionary, is a “handheld device that aids in accomplishing a task.” [MW03]. Another description for a tool is an instrument that makes changes on other objects, as by cutting, rubbing, striking, measuring, or other processes. Tools are the primary means by which humans control and manipulate their physical environment.

Tools play a particularly important role in kitchen, and are further categorized into subdivisions such as cookware, kitchenware, and utensils. A “kitchen”, in the way people normally refers to, is essentially a storage space for ingredients and tools, and a workspace to create delicious dishes from raw food using the tools. To transform raw materials into presentable dishes requires a combination of fresh ingredients, the right tools, and capable people. Without the right tool, a talented chef would be limited if he could only work with his hands – whisking eggs would be

much slower; rolling bread dough would require a lot more effort; without a bowl, he could not even mix properly.

Interestingly, the first known tool made by human beings was used in food processing, and resembles much to today's knives. About 2.6 million years ago, at the beginning of Paleolithic Age, forerunners of modern humans used a pebble tool, which archeologists called a chopper, to cut through the skin and sinews of the animals they hunted. A chopper is typically a water-worn, fist-sized rock with a roughly serrated edge, and became the only tool used by humanity for almost 2 million years until the appearance of hand axe, a superior version of the chopper. [EB]

Ever since the Industrial Revolution, kitchenware has remained largely static. As mentioned before, tools have made their way into the kitchen much more slowly than they have in other arenas. Many new concepts and products had been marketed, but few appliances have been accepted into consumer's kitchen. Those that have, such as microwave oven and bread machines, are usually mechanical, passive, and unaware of the environment surrounding them.

In contrast, an intelligent tool, in the context of the kitchen, would be active, adaptive, and self-aware. It would understand the actions and intentions of the user, analyze how it could adapt to the user's need, and respond with the appropriate actions or suggestions that help the user in achieving his goal. It could also help the user to understand his environment better, by aggregating information from the surroundings and representing it in a relevant, user-friendly manner; or even better, the tool would be able to coordinate with other elements in the kitchen to introduce a cohesive picture to the user, and to avoid contradicting suggestions.

The individual technologies to develop tools of this kind are well within reach. Intelligent kitchenware, however, is still considered a "tool of the future" because of a lack of understanding of the real human needs and their corresponding solutions, and the absence of a necessary "glue" that bonds the right technologies to a solution. The difficulty lies not in putting sensors on every possible tool, but in identifying the factors that contribute to an effective tool and developing technologies that enhance those qualities. Obviously, good engineering skills are necessary in the creation and implementation of the technologies, but also necessary are creativity in using existing capabilities to solve new problems, and a sound understanding of human wants. The core issue is not about the design of a single tool, but the application and interaction of every tool with the user, with each other, and with the surroundings, and how they, together, can fulfill the user's need and solve his problems.



## CHAPTER 2. **FOOD CHEMISTRY**

Cookery is often viewed as an art, because of its emphases on skills, creative imaginations, and aesthetics. This may be true for an experienced chef working in a well-equipped kitchen, but not necessarily applicable to exposure. In fact, anthropologists point out that the human civilization did not begin until our ancestors mastered fire in preparing food [FM96], this theory puts cooking at the center of our evolution.

There are generally three different views on cooking – skill, art, or science [Da99]. The skill view stems from medieval cookery texts, in which many manuscripts depict cookery as acquired expertise. The art view, which admires cookery as a mixture of instinct and taste, has been dominant since the 16<sup>th</sup> century, and remains largely so till now. During the 19<sup>th</sup> century, people started to realize the systematic knowledge behind cooking, and the aspect of science that underlies cookery came increasingly to be noticed. In the book *Science in the Kitchen*, Kellogg wrote [Ke10]:

*“Cookery, when based upon scientific principles, ceases to be the difficult problem it so often appears. Cause and effect follow each other as certainly the preparation of food as in other things; and with a knowledge of the underlying principles, and faithfulness in carrying out the necessary details, failure becomes almost an impossibility.”*

With the emergence of the science view, and the modernization of the kitchen following the Industrial Revolution, more scientific equipment was designed for and used in the kitchen. Balances are used to weigh food to be cooked; thermometers are adapted to measure temperatures of freezers, ovens, and food; and salometers<sup>1</sup> are designed to determine the

---

<sup>1</sup> Also known as salimeter, salinimeter, or salinometer.

salinity of brine used in pickling and canning. The field of food science began to flourish, and many branches were developed. Some focus on the safety aspect of food, others, on health; yet most usually emphasize the intake and genetics of food, but not the preparation. Despite its destined course with repeated actions, cookery remains primarily a craft, because few efforts are devoted to expound the language and metrics that ensure reproducibility.

Compare to other disciplines of science and engineering, computer engineering is a pioneer in the area of cookery. The first computer designed for use at home was a kitchen computer, but after its failure, kitchens became the Bermuda triangle for computers. Even in an era when computers have penetrated almost every corner in the household, the kitchen stays as a sanctuary where no artificial intelligence is allowed to set foot on.

This section looks at today's methods of measuring certain physical and chemical properties in food, surveys the types of kitchenware available on the market, and proposes a new view on these different properties; at the end it also discusses the diverse ancestry of computers in the kitchen. With this information we can start designing a new type of cookware for the kitchen of the future.

## **FOOD CONTENT AND MEASURING INSTRUMENTS**

Kitchens today usually have a sizable and diverse collection of cookware; ironically most of them are very specific and task-oriented. A thermometer only measures temperature, and can do little else. Only very few digital thermometers can even serve an extra function as a timer. Here we look at the function of certain physical and chemical properties of food in cooking, and methods used to determine them in an ordinary home kitchen. In particular, we examine the equipment available for testing various properties in food.

### **SALINITY**

Salt is an essential condiment, even for food that does not taste salty. A moderate amount can be used for taste in salty dishes. A very small amount can be used to enhance the sweetness in sour food, such as pineapple and grapefruit, and improve the flavor balance in sweet bakery goods. A generous amount can be used, together with vinegar and other spices, to preserve food [Da99].

In many cases salinity only matters for taste, but for some it matters because it has an effect on the quality of the finished product. Salting is an ancient food preservation technique<sup>2</sup>. Impregnating the food with a high concentration of salt draws moisture out from the cells of food by osmosis. This creates an environment inhospitable to bacteria by inhibiting their usual way of feeding and preventing them from reproducing [BrM]. Salt also stops the activity of enzymes by upsetting the electrical balance of the liquid, and preventing decay caused by enzymes. This can be observed when a sliced apple is put in brine to stop browning. In both situations, if the brine is not strong enough, bacteria grow and enzymes remain active, causing the food to rot. In some preparations, instead of inhibiting all bacteria, people intentionally introduce certain lactic acid-producing bacteria because they bring about desired fermentation. Generally these bacteria can tolerate stronger solutions than the decay-causing ones, so a moderate amount of salt is used to allow the growth of these bacteria while inhibiting other harmful ones. The amount of salt added must be controlled very carefully to find a common ground between the two extremes. This calls for an objective, exact measurement of salinity.

Salinity can be measured in many ways. An old cook's advice is to "make brine strong enough to float an egg"<sup>3</sup>, but this method tends to encourage more salt use than necessary, as it can only tell whether there is sufficient salt but not if there is an oversupply. Modern recipes usually give clear instructions on the amount of salt and water in the unit of tablespoons and cups, or advise cooks to consult conversion tables [Hi99] to determine the ratio of salt and water for a particular salinity. This ensures the concentration of the initial solution, but since the salinity of the final product depends on the initial solution concentration as well as the volume of water inside the food, it does not guarantee that the final solution is salty enough. In some cases, such as the fishing industry, where salinity is paramount in meeting regulatory requirements, workers enlist expensive equipment and complicated methods to ensure that the food is well salted [Hi00]<sup>4</sup>.

A precise way to determine salinity in a home kitchen is to use a salometer or a hydrometer. Both function in the same fashion – a weighed, sealed, long-necked glass tube with markings is read according to how far it sinks into a solution. It is the same principle as using an egg, since both

---

<sup>2</sup> The origin of salting is lost, but processed meat can be dated back to 3500 B.C. [PT84], and has been widely popular since the Roman Empire.

<sup>3</sup> Indeed many pickling recipes call for brine without specifying a salt-to-water ratio; instead they use egg flotation as the benchmark for appropriate salinity of the solution. Since saltwater has a higher density than fresh water, adding salt into fresh water would eventually cause an egg, the density of which is in between, to float.

For further details refer to recipe for "trash can pickles" on <http://www.cooks.com/>, or the Homestead History on the PBS feature "Frontier House," available at [http://www.pbs.org/wnet/frontierhouse/frontierlife/essay6\\_2.html](http://www.pbs.org/wnet/frontierhouse/frontierlife/essay6_2.html).

<sup>4</sup> The procedure detailed in this document is supposed to be quick compared to sending samples for laboratory testing, but it involves equipment over \$450 and solving several equations, which render it infeasible for home kitchen.

rely on the fact that salt and sugar solutions have higher densities than water. The depth of flotation gives an indication of liquid density. With little solute, the tube sinks, and it rises up with the concentration. The difference between a salometer and a hydrometer is the calibration on the tube. A salometer tells how much salt there is in a solution, thus the marking is inapplicable to other liquids such as syrup. A hydrometer approaches the question of density from the other side: how much water is there in your salt? Therefore, it can register the point to which the glass tube sinks in not only a solution of salt, but also sugar or anything else that dissolves. It uses a scale developed by a French chemist, Antoine Baumé. The scale measures specific gravity on evenly spaced scales, and can be used to measure the density of brine and sugar syrups.



**Figure 1:** Matfer Salometer (left) and Matfer Syrup Density Meter (right, technically known as hydrometer)

In industry or research, multi-meters with salinity function are used to measure salt concentration with amazing accuracy. Few meters are devoted solely to salinity; they are usually combined with conductivity, temperature, and acidity. The setup of these meters is quite bulky, so their design fits better into a chemistry laboratory than a domestic kitchen.

The irony is, the most accurate equipment is perhaps the least used. Multimeters are never used in kitchen; salometers and hydrometers are rarely found in home kitchens, even ones that process a lot of pickles and jams. Cooks either rely on the old method of egg floating, or worse, simply guesstimate the amount of condiment required without an objective judgment. This problem can be attributed to the highly specialized design of the salometer – its sole purpose is to measure the amount of salt in brine, but not salt in stew, or batter, or salad dressing, which are the more common types of home food. There is a need that cannot be realistically fulfilled by



equipment used in professional kitchens, hence there is a need for a device that can measure salt in a broader application, and that is more suitable for home kitchens.



Figure 2: Two multimeters with salinity function.

## TEMPERATURE

Temperature is a useful indicator in cooking that gives crucial information about the food. It is also the single most well-developed and common property that is measured when cooking. Before thermometers were used in kitchens, chefs use some very creative methods to determine the temperature of their food. Instead of getting objective readings and interpreting them by looking up tables, they observed the visual, olfactory, and textural quality of their ingredient to ascertain that it had the suitable temperature for their use. For example, in 18<sup>th</sup> century cookbooks, candies were made by noting the texture of the sugar solution while boiling; a small amount of the syrup is dropped into cold water and taken out, if the syrup is soft and pliable into a ball, then it is ready for making fudge.

With the advent of food thermometers, many of the ancient techniques faded out. Nowadays thermometers are used for various purposes in cookery, the two most important ones being safety and quality of the food.

- **Ensuring food safety.** Heat kills most of the harmful microorganisms that get into food, especially those in meat. The government issues clear food-safety guidelines on how much heat is needed, such as cooking ground beef and eggs to 160°F to kill *Listeria*, *Salmonella*, and other harmful bacteria that may cause diseases. [US01].

- **Enhancing the quality of food.** Many foods and cooking styles require careful temperature control for optimum flavor and texture. In deep-frying, the temperature of oil has to be monitored closely throughout the process to ensure quality: too low, and the food will emerge pale and greasy; too high, and the exterior will scorch and toughen [Da99]. Even worse, extreme temperature can cause oil to smoke, changing its color and flavor and rendering it useless. Temperature is also of tantamount importance in chocolate- and candy-making. Different textures can be achieved by arresting a boiling sugar solution at different temperatures, resulting in a variety of confections. Chocolate needs to be tempered before decorative uses, a process that consists of melting the chocolate and holding it at a specific temperature, then lowering the temperature to a precise point, and raising it up again to another certain temperature.

Thermometers are omnipresent in modern, professional kitchens; some kitchens even have several types for different purposes. Three methods of measuring temperature are employed in thermometers – bimetallic, mercury, and electronic. The dial (bimetallic) type is mostly used in freezers and ovens, and also in meat; the electronic type is very popular in meat thermometers, while deep fat, candy and jelly thermometers utilize the traditional mercury type.



**Figure 3:** Kitchen thermometers. Clockwise from upper left: Matfer candy thermometer, Polder Preprogrammed cooking thermometer, Pyrex oven thermometer, Taylor digital instant-read pocket thermometer, Taylor professional meat thermometer, Taylor candy/jelly/deep-fry mercury thermometer.

When choosing a thermometer, its construction and sensitivity are the two criteria that deserve special consideration. Sensitivity determines how fast the equipment responds to temperature changes, and construction dictates how it can be used. For example, mercury thermometers are highly-valued due to their sensitivity and exceptional heat tolerance. However, since mercury is a highly toxic liquid, and there are many government regulations covering its use<sup>5</sup>, some leading manufacturers feel that it is no longer practical to market products containing mercury to consumers [WAF00], so the dial style prevails. Mercury also is inappropriate for meat thermometers because of their frailty; the force required to pierce through the meat and insert the bulb may break the tube, resulting in mercury spillage. Most meat thermometers today are either dial or electronic, with a pointed metal probe that can penetrate the food to reach its inner part. Delicate foods such as chocolate necessitate a highly responsive and accurate instrument. In this case, mercury thermometers that function within a narrow range of temperature (50°F to 140°F for chocolate) with wide, one-degree gradations that are easy to read are very much desired [Wi86]. To reinforce the construction, some manufacturers put their thermometer inside a metal cage and fit it with cork bumpers for protection against breakage; some also include clips that allow cooks to hang them on the edge of a pot.

## **ACIDITY AND CONSISTENCY**

Acidity and consistency are two properties of food that are largely unexplored in cooking. Not that they are unimportant in the cooking process, but avant-garde cooks, cookbook writers, and food scientists have left them out for some inexplicable reason. Neither of them has an objective way of being described in cooking, and, especially for consistency, vague expressions such as “If the mixture seems thick, add more water” are commonly used to convey the intention of the recipe writers.

If acidity can be dependably and conveniently evaluated in food, using natural acid becomes easy – lemon juice and other sour foods can be added liberally without worrying about their sourness. The initial sourness fluctuates from each lemon, depending on the weather, genetics, and many other factors. If the lemon juice is sourer than usual, its pH is lower and a smaller amount is needed to achieve the same acidity as some less sour lemon juice; if a fixed volume of juice is added despite the initial sourness of the lemon, the taste of final product could vary significantly.

---

<sup>5</sup> In recent years, some municipal governments established very strict regulations, or put a ban altogether, on the use of mercury thermometer. For a sample of the rules imposed on mercury use, refer to the law expounded by the town of Natick, Mass.

[http://www.noharm.org/library/docs/Natick\\_MA\\_Mercury\\_Thermometer\\_Regulations.htm](http://www.noharm.org/library/docs/Natick_MA_Mercury_Thermometer_Regulations.htm).

Thus measuring the acidity of the food and comparing it to a pre-determined pH is more scientific than adding a fixed volume, giving the cook more control over the final product.

Consistency is of equal importance in cooking – often, the amount of a particular ingredients is adjusted according to the consistency of the mixture. For example, when making pancake batter extra milk is needed if the batter “seems thick”, but for a novice cook whom never made pancake before, the question is “How thick is thick?” The problem is made worse by the fact that different food has a different definition on thickness and stiffness; cream of mushroom soup is a lot thinner than pancake batter, and the word “thick” can mean entirely different consistency in the two dishes. A common sense exists in discerning the appropriate thickness for various dishes, but for first-time cook, this is a recipe for disaster.

To ensure the reproducibility Kellogg mentioned, it is crucial to standardize the metrics of acidity and consistency, and hence the need arises for a more structured way to describe both properties. In science and engineering, both acidity and consistency have very rigorous definitions and means of calibration. The concentration of acid has to be strictly controlled in various chemical process such as electroplating, and is measured using the pH scale. The scale corresponds to the concentration of hydrogen ions in an aqueous solution, and ranges from 0 to 14, with 7 meaning neutral. Acidity is measured using a pH meter. Many models exists, but their accuracy is usually proportional to their complexity – the higher precision meters are large, or are made out of glass probes, or have multiple probes and require multiple steps of calibration regularly.

Consistency, technically known as viscosity in engineering, is an internal property of a fluid that offers resistance to flow. It is frequently referred to in fluid mechanics, and is measured in units of Pa s (Pascal seconds). There are many ways to measure viscosity, including attaching a torque wrench to a paddle and twisting it in a fluid, seeing how fast a fluid pours through a hole, using a spring to push a rod into a fluid, or using a vibrating fork. Normally used in more task-critical circumstances, viscosity meters are heavy duty and made to last, but also expensive and unsuitable for home use.

## **FOOD CHEMISTRY – A NEW VIEW**

This section is devoted to a new way of looking at three of the food properties mentioned above: salinity, acidity, and consistency. Temperature is not included in this discussion because there is a well-established system for measuring it, and the system has already been fairly well adapted

for kitchen use. This new view aims to shed light in the developments of such a system in other properties, and via the development endeavor, to create simple instruments that can be used effectively in the kitchen.

## SALT

As mentioned above, the current way of measuring salt in kitchen focuses on determining the density of the solution. When the solution is not pure brine, the equipment built based on this principle fails. Thus a salometer cannot be used in stew, or batter, or salad dressing.

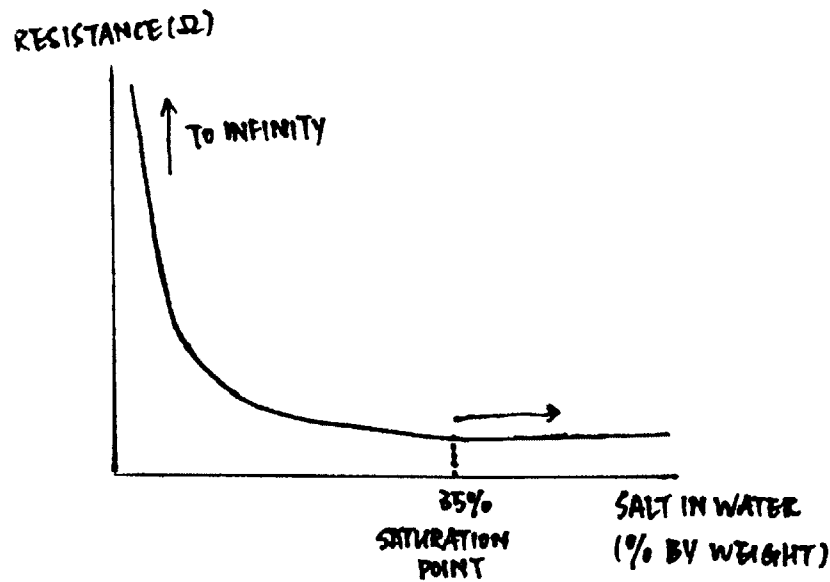

**Figure 4:** The relation between salinity and electrical resistance expressed in a graph. Pure water is an insulator, and has infinite ohms of resistance. As the salinity increase, resistance decreases. The curve reaches a valley at one point when the solution reaches saturation and can absorb no more salt; at this point, more salt does not decrease the resistance further.

Laboratory multi-meters, as seen above, measure the conductivity of a solution to determine its salinity. Electric current passes much more easily through water with a higher salt content. Distilled water, with no dissolved minerals or impurities, is an insulator, but as sodium chloride (normally known as table salt) and other chemical salt is added, its conductivity increases. Capturing this property of water, we can measure the salinity of a solution by measuring its

conductivity, or the inverse, its resistance. Resistance is defined in the units of ohms ( $\Omega$ ), and can be easily calculated by applying a small, known voltage between two metal probes and observing the resulting current.

The drawback of using resistance to measure salinity in food is that, apart from salt, other chemicals in food also change its conductivity. For example, other soluble chemical salts that occur naturally in some of the ingredients can cause the conductivity to fluctuate, but not necessarily change the salinity. Acid might change salinity too, depending on what chemicals and metals are involved in the process. This problem can be mitigated by two actions – by using non-reactive metals for the probes in the instrument, and by calibrating the readings individually for some particular problematic recipes. To diminish the effect on resistance caused by any chemical reaction between acid and the probes' metal, the probe can be made out of gold or platinum; alternatively, to reduce the cost, it can be finished in gold- or platinum-plated metals. For most of the recipes, salinity can be read directly from a chart or a graph, with acceptable accuracy. Some recipes may contain acidic ingredients that can upset such a graph, but they are a minority and can be remedied by calibrating their effective salinity with the readings from the device.

## **ACID**

Acid can affect the conductivity of the solution, as mentioned, and may interfere with the determination of salinity. Every coin has two sides, fortunately, and the advantage of this behavior is that acidity can also be effectively determined by measuring conductivity. The dual characteristic of electricity is phenomenal. It implies that with the same principles and same circuitry, a tool is able to measure both salinity and acidity. The only differences lie in the construction of the probes and the conversion table.

For salinity, any metal can be used, because conductivity is measured in terms of the solution's capability to carry charges across the probes, or the number of free ions in the solution, and the probes remain inert during the measurement. For acidity, the two probes must be made out of two different kinds of metals with different reduction potential. Acidity is measured in terms of the free  $H^+$  ion in the solution; the more acidic a solution is, the more  $H^+$  ion it has. If two connected metal pieces with a reduction potential are placed into an acidic solution, they undergo reduction/oxidation (redox) in which the metal with the higher potential donates charges, and the acid is oxidized. For example, if zinc and iron are placed into strong hydrochloric acid (stomach acid), the zinc piece is corroded and hydrogen gas is formed around the iron piece. Since zinc

has a higher reduction potential than iron, when they are electrically connected the zinc atoms donate electrons and is oxidized ( $\text{Zn} \rightarrow \text{Zn}^{2+} + 2\text{e}^-$ ), and the hydrogen ions in the acid receive the electrons and are reduced ( $2\text{H}^+ + 2\text{e}^- \rightarrow \text{H}_2$ ). Together the whole reaction can be represented in the equation  $\text{Zn} + 2\text{HCl} \rightarrow \text{H}_2 + \text{ZnCl}_2$ . The iron remains inert during the process, and a current is formed between the two metals.

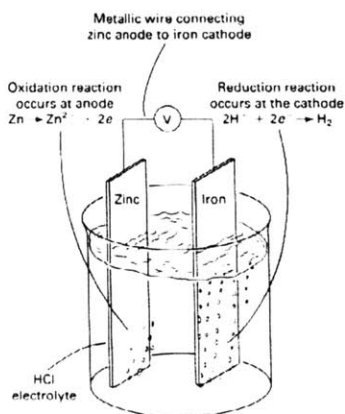

**Figure 5:** Reaction between connected zinc and iron plates, and hydrochloric acid. Note that zinc is corroded and hydrogen bubbles are formed around the iron plate.

The magnitude of the current depends on several factors – the reduction potential between the metals chosen, the temperature in which the reaction takes place, and the strength of the acid. Between a fixed pair of metal pieces, a stronger acid generates a greater current; the strength of the acid can be determined by measuring the current with an ammeter. To increase the sensitivity of this setup, two metals with a greater reduction potential should be used to magnify any turbulence in the acidity of solution.

The disadvantage of this method is that it is interfered with by salinity. Salinity in food affects the conductivity between any two metals; thus apart from the concentration of  $\text{H}^+$  ions, the setup is also measuring the concentration of any dissolved, charge-carrying ions in the solution. If salinity is also measured with two inert probes, the problem can be solved computationally by compensating the effect of salt in the solution when calculating the actual acidity.

## CONSISTENCY

Common sense tells us that if a liquid or a paste is viscous, it is difficult to stir. When stirred with a spoon, the stiffer it is, the more pressure it exerts on front side of the spoon; with this pressure the

spoon bends by a very small amount. By measuring the degree to which the spoon bends, it is possible to extrapolate the stiffness or the consistency of the food being stirred.

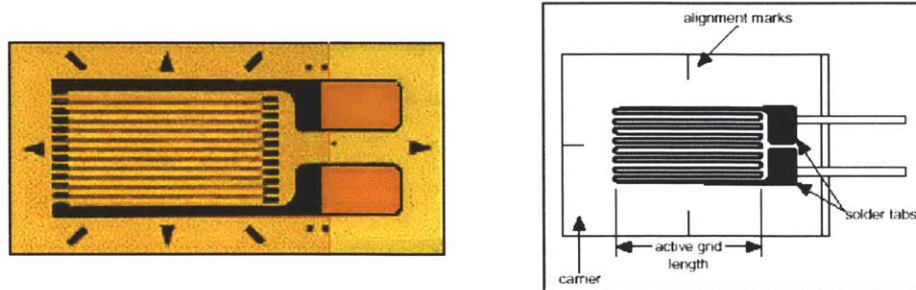

**Figure 6:** Uni-directional strain gauges. The left shows a photo of a strain gauge, and the right is an annotated one. The direction of strain measured is parallel to the direction of the grid.

Deflection of surfaces can be measured by strain gauges. Strain is defined as the amount of deformation of a body due to an applied force, and a strain gauge measures the variance in electrical resistance in proportion to the amount of strain in it. This amount is usually very small – almost negligible to human senses – but can be picked up by a gauge. Strain gauges come in many forms and packaging. The most common type, a metallic gauge, consists of very fine wires or metal foil arranged in a grid pattern. The grid is usually uni-directional, and is capable of measuring only strains in a particular direction. The grid is bonded to a very thin backing, which is attached directly to the test specimen. The strain experienced by the specimen is directly transferred to the gauge, which responds with a linear change in resistance. For the strain to be accurately transferred from the test surface to the gauge, it must be properly mounted onto the specimen. Special surface cleaner and glue are usually applied in attaching the strain gauges, and the gauge must be staged in the right direction to function correctly.

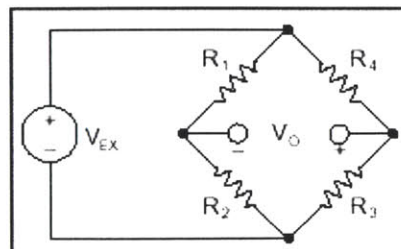

**Figure 7:** Wheatstone bridge.  $V_{EX}$  is the excitation voltage, and  $V_o$  is the output voltage.



Due to the minute change in the strain of the surface, the derivation in electrical resistance is tiny. For example, in a 250Ω strain gauges, the change in resistance is less than 1Ω under most circumstances – less than 0.4%. Most electronics are unequipped to detect such small shifts, and a Wheatstone bridge is often used to amplify the difference in resistance. Figure 7 shows the circuit diagram of such a bridge. The output voltage,  $V_o$ , is equal to

$$V_o = \left[ \frac{R_1}{R_1 + R_4} - \frac{R_2}{R_1 + R_2} \right] \cdot V_{EX}$$

When  $R_1/R_2 = R_4/R_3$ ,  $V_o$  is equal to zero, and the bridge is said to be balanced. At this point, any changes in any arm of the bridge results in a non-zero voltage output. If  $R_4$  is replaced with a strain gauge with appropriate resistance, any changes in the resistance of the gauge tips the balance of the bridge and results in a non-zero  $V_o$ ; the changes in resistance can then be calculated. Such a setup is called the quarter-bridge circuit. To further increase the sensitivity of the bridge, two strain gauges can be applied to both sides of the surface, one for tension and the other for compression, and use a half-bridge circuit to double the sensitivity.

There are many factors that can decrease the accuracy of strain gauges. Temperature is the number one enemy – Ideally the resistance of strain gauge should only be change in response to applied strain; however, gauge material, as well as the test material to which the gauge is applied, expands or contracts with temperature changes. To reduce the effect of temperature, a dummy gauge, with grid pattern arranged in perpendicualar to the other, can be use in conjunction to the real gauge. The strain in another direction has little effect on the dummy, but any changes in temperature affect both gauges in the same manner. By knowing the change in resistance in the dummy, the temperature effect on the real gauge can easily be factored out.

## IMPLICATIONS

With this thorough discussion on food chemistry, a new view on different food properties, and a detailed description of the devices necessary to measure them, we are ready to incorporate these technologies into the design of context-aware cookware. Making a fundamental change in the view towards food properties is important. It enables one to see the ordinary from a new perspective, and equips a person with indispensable knowledge that is a prerequisite of the path to innovation. In this research, this is done with cross-reference to existing technology in other

disciplines of study, and by reducing a new problem into smaller problems that have already been solved.

We shall, however, take a detour to look at what has been done previously in the arena of computing in the kitchen, and apply the lessons learned in these attempts to our own endeavor.

## CHAPTER 3. PREVIOUS WORKS

Previous work on the topic of computer-aided cookware can be divided into two main categories: computer-aided cooking, and integrated cookware. Previous attempts of building computer-aided cookware similar to the Intelligent Spatula project are yet to be found; however, there are literature about computer-aided meal planning and cooking, and also products that integrate several types of equipment into one.

### COMPUTER-AIDED COOKING

In 1966, Jim Sutherland, an engineer with Westinghouse Corporation, built the first computer dedicated for domestic use. It was known as Electronic Computing Home Operator, or ECHO IV, and was intended to relieve his wife of some the household chores. It can compute the family finances, and as of April 1968, Sutherland was extending the system to store recipes, compute shopping lists, and track family inventory [Sp00].



**Figure 8:** Electronic Computing Home Operator, ECHO, was designed and built by Jim Sutherland in 1966.

Not long after, Honeywell marketed the first commercial kitchen computer, and it was featured on the front page of the 1969 Neiman-Marcus catalog. The Honeywell H316 Kitchen Computer was a \$10,600<sup>6</sup> minicomputer designed to store recipes, but with no means to input or output characters; users could only interact with the built-in recipe files through switches on the front panel. The purchase came with a two-week programming course, in a language known as BACK. Considering the computer literacy level of the general population in the 1960s, the product was absurd from a consumer point of view, and is often cited as a commercial disaster – as far as is known, none were ever sold.



**Figure 9:** Honeywell H316 Kitchen Computer. The left shows a marketing brochure for the computer, "If she can only cook as good as Honeywell can compute." The right is a close up photo of pedestal version.

Two reasons can be contributed to the failure of the Honeywell H316. The first is technical, and the other is cultural. Technically, the technology in the 1960s was not mature enough to design a computer that could be used in the household; the interface is simply too hexed that it is unreasonable to expect a layperson to understand it. Culturally, the person who could afford such

---

<sup>6</sup> This is the price of a small suburban house in the 60s.  
28

a computer, which could not do any real cooking and did nothing more than store recipes, would most likely have opted for a live-in chef or revert back to the old 3"x5" recipe cards.

Although no kitchen computer was introduced until a long time after H316, many people have envisioned a computer in every single kitchen, and many have wondered how they could harness its full potential. According to David Goldbeck [Go89], computers in the kitchen can be used in many different ways.

- **Meal planning.** By using a nutritional analysis program, recipes can be broken down into nutritional constituents. This is especially beneficial in planning meals for people with health conditions such as diabetes.
- **Recipe indexing.** Recipes can be stored on the computer, and indexed by ingredients, preparation time, and cooking methods. This reduces the amount of physical space necessary for a large repository of recipes, and facilitates the search for recipes.
- **Shopping and pantry storage.** With information about food inventory, price and sources, compilation of a shopping list is made easy.
- **Entertaining with ease.** With appropriate software the host can easily store and retrieve food preference of his guests; information about dishes served is useful to avoid serving the same food multiple times. If there is a special menu it can be preserved for future use, along with the adjustment necessary for better taste.
- **Computer bulletin boards.** If connected to a network the user can chat with other online users to exchange ideas and experience, or to ask questions about cooking or nutrition.
- **Stereo, television, and VCR.** The computer can be used as an entertainment center in the kitchen.

It is surprising to note that Goldbeck's hope for kitchen computers, written in 1989, is still consistent with the general public's expectations today. Even with the advent of the Internet, the networking power of modern appliances has been used to achieve mostly the goals outlined above.

Since the introduction of Honeywell H316, numerous endeavors have been made to improve kitchen computing. A glimpse of what is available now shows refrigerators that can access the Internet, communicate with other appliances in the kitchen, keep track of food inventory, and serve as the messaging center of the household. Retailers sell microwave ovens that can recommend dishes according to food available, use sensors for automated cooking, and retrieve new recipes from the Internet. There are also washing machines that can download washing

programs to wash clothes<sup>7</sup>. However, price tags on these computerized appliances are high, and they are not commonly seen in an average kitchen.

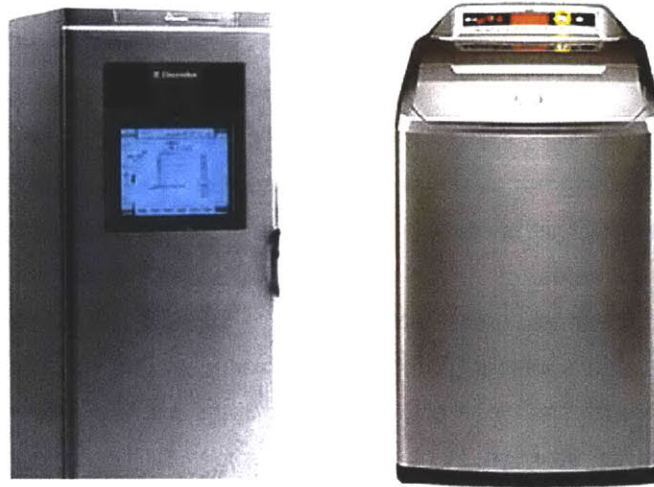

**Figure 10:** Internet-ready appliances. The Electrolux Internet-ready refrigerator (left) keeps track of inventory, compiles shopping lists, and is an entertainment center. The LG Internet-ready washing machine (right) can download new washing programs from the web to keep itself updated with the latest technology in fabric care.

Poor interface design is a major weakness in existing kitchen computers – most resemble desktop computers in offices and are lacking in user-friendliness. Many designers employ traditional computer interface with icons and windows for users to click through; therefore another layer of work is required on top of existing ones [Ma00]. The smart refrigerators and microwave ovens are passive devices that require active user involvement, and the demand interferes with ordinary kitchen chores. The lack of transparency in the interface distracts users from the real task and lures them to focus on the interface itself, and as a result many cooks feel that kitchen computers are obstacles rather than help.

---

<sup>7</sup> Electrolux built a showcase Intelligence House, at Varmdo, Sweden, where all kitchen appliances networked; information is displayed on the Screenfridge, and can also be sent to a WAP phone. The fridge doubles as a web-based telephone, television, radio, and provides storage for shopping lists and family calendar. Whirlpool released an internet-ready fridge in mid-2000, and so did Samsung a year later. Besides fridges, LG Electronics unveiled a microwave oven and a washing machine that are internet-ready. Panasonic also make smart microwave ovens, and Sharp even puts sensors into the oven to determine cook time and power levels for popular foods.

## **INTEGRATED EQUIPMENTS**

Certainly there is life beyond the kitchen computer. In fact, between H316 and now, many kitchen utensils have been designed, most without computers in the designers' mind. New cookware has inventive materials, better ergonomics, and more sensible design. One characteristic that was not changed – almost all of them are still single purpose. They perform to amaze on the job they are designed for, but that is where their ability ends. A whisk is for beating and cannot scrape, a cutting board is for chopping and cannot drain, and a coffee machine is used for making coffee and cannot be used for milkshakes. It is impossible to disparage the convenience brought by whisks, cutting boards, and coffee makers, but as activities inside a kitchen increase, and advances in technology bring more electrically powered machines into the kitchen, the modern kitchen cabinets are starting to fill with different equipments that serve only one or two purposes, and multiple tools that do the same job. The curious point is that the most versatile tools are usually the simplest. Consider the hands, they are kitchen tools made out of 5 moving parts, and are ideal for kneading, gripping, twisting, whisking, and many other tasks. The fork is another modest tool, and is capable of lifting, whisking, piercing, and stirring. More complicated tools with specialized applications may save time and energy, but as tools become increasingly restrictive they are losing their original simplistic elegance.

Kitchen equipments that combine several functions into one are fairly uncommon. The most commonly seen tool is a combination of digital thermometer with kitchen timer. In essence, it is a digital thermometer with a built-in timer. While they serve every function of a digital thermometer, most of them are quite deficient in their timer functions. Some do not have countdown function, many have only one timer, and most do not have the interrupt feature that allows the timer to be stopped temporarily. All in all, the thermometer-timer available on the market nowadays could be significant meliorated.

Another hybrid that entered the market in the 70s is a mercury thermometer encased in a spoon. The spoon had a hard chrome stem and bowl with a melamine handle and plastic-capped thermometer. It had a wide operating range of temperatures – from 50°F to 450°F – but was not very accurate, and therefore unsuitable for heat-sensitive tasks such as chocolate tempering. The sensor element of the thermometer was located at the joint between the handle and the bowl. Since it was filled with mercury, the user had to exercise extra care when using the spoon. This thermometer-spoon has been judged a design failure, partly because the spoon shape limits its use as a thermometer, while the care essential for a thermometer limits its use as a spoon. One comment describes the spoon as “a caprice, but it is not without its uses” [BG75]. The manufacturer has long stopped the production of the thermometer-spoon.



**Figure 11:** Rösle classic cooking spoon (left). The spoon is constructed of wires that are straight on one side, curved on the other, and zigzag in the center. The sides can be used to scrape pans bottoms and side of bowls, and the middle part acts as a whisk. The wires are made out of 18/10 stainless steel, and there are no sharp edges so it is safe on non-stick pots and pans.

Both the thermometer-timers and the thermometer-spoon are de facto reflections of the design of integrated kitchenware – few exist, and among the few, most need major improvements. On a more positive note, there are some multi-purpose kitchen utensils that are beautiful and usable. For example, Rösle has manufactured a cooking spoon that is a marriage between design and practicality. It can be used as a spoon to stir and scrape, but can also serve as a whisk to mix; it is durable, heavy duty, dishwasher safe, and can be used on non-stick cookware. The design is meticulously thought out: the button on the neck of the spoon adds balance so that if the utensil is left unattended in shallow cookware, it cannot somersault out from the weight of the handle. Although it cannot be used to scoop food, this spoon serves as the archetype of what can be achieved when cookware is designed with careful attention to details.

From the above examples, we can establish some rules about designing integrated utensils or smart kitchen tools:

- **Keep things that are not broken:** If the design is based on tools that are widely used, or is intended to replace an existing tool, the designer has to be very careful about keeping the desirable features in the new tool. Most users have a strong reluctance to try out new gadgets, especially to replace functional, albeit mediocre, ones. The thermometer-spoon lacks the accuracy of traditional thermometer and the robustness of a regular stainless steel spoon, which spells its eventual decimation. If an important feature that exists previously is now missing in the new tool, users will not hesitate to revert to their old one.



- **Backward compatibility.** The new tool must support the activities that can be done with the existing one, and be compatible with its surroundings. This is true as a general design principle, not just applicable to kitchen tools. The Honeywell H316 kitchen computer, although without predecessor, is not designed to fit into the domestic ambience of a kitchen, and this leads to its failure.
- **Keep things simple:** Simple tools are most welcomed, due to their low cost of learning and minimal maintenance. People also tend to use simple tools more, which reinforces their familiarity with the tool and sways their preference towards it in the future.

To put the lessons into practice, we built a kitchen tool by applying the new view on food chemistry and the lessons learned from previous attempts.



## CHAPTER 4. **THE INTELLIGENT SPATULA**

What is home?

*A house?*

*A place where family is?*

*A TV and a couch?*

*A place to relax?*

Home is generally considered as the contradistinction of office or workplace; it is a place to wind down and relax, to socialize with families and friends, and to have fun. Since the connotation of a computer is work and productivity, there is a widespread aversion to introducing it anywhere at home except the study. The kitchen, in particular, faces the greatest resistance – the computer is thought to have nothing to do with cooking, what could be done with a kitchen computer can also be done as easily without.

Certainly, it is arguable that the Internet dispenses part of the myth – there are websites that give out free recipes for downloading, chats rooms dedicated to cooking discussions, and experts and chefs that answer questions via email. A closer examination of these activities, however, reveals that the Internet did not fundamentally change the common way of cooking; it merely facilitates the communication and other peripheral processes involved in a traditional kitchen. Take recipe searching as an example. Until very recently, cooks got their recipes from cookbooks, television shows, or by word of the mouth; they then made a quick assessment on the reliability of the recipe, wrote down the ingredients and the procedures, and brought that piece of paper into the kitchen to follow. Nowadays, people are beginning to use the Internet as an extra channel for getting recipes. Nonetheless, chefs still have to follow the same procedure as before in order for

a recipe to become food on the dining table. The Internet does not enhance the chef's confidence in the recipes obtained, nor does it accelerate the process of turning the recipe into real food.

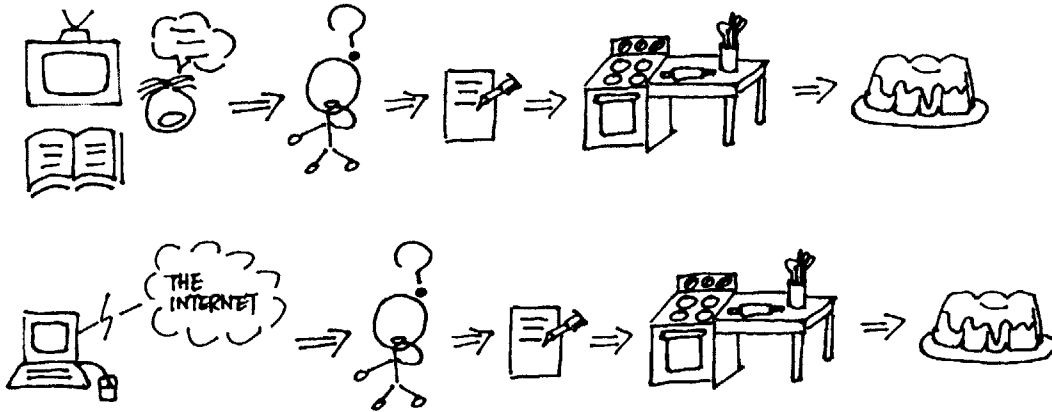

**Figure 12:** The recipes search. Without the Internet, recipes come from television shows, books, or word of mouth. One has to judge the quality of the recipe, write it down, and carry out the necessary action in the kitchen to produce the food. The process is not changed by the presence of the Internet.

The goal of the intelligent spatula is to refute conventional wisdom that a computer has nothing to offer the world of cooking. With a creative and well-executed interface in the form of a spatula, a computer in kitchen can increase efficiency, increase a novice's confidence level, and add to the joy of cooking.

## **SYSTEM DESCRIPTION**

The following section describes the technical details of different versions of the prototype. The intelligent spatula went through a series of increment changes to evolve to its current state. The original idea was based on previous work by Erik Olsen and Rocelyn Dee[OD02], with the help of Ernesto Arroyo, which proposed a smart sensing spatula that provides quantitative feedback to its users. The spatula can detect different physical properties of the food and track their changes, and report the data to a computer, where the data can be further manipulated to offer germane suggestions about the next steps.

## ORIGINAL PROTOTYPE

Their original prototype was made of plastic and had various sensors for measuring different physical properties of the food with which the spatula was in contact.

Material	Vacuum-formed polyethylene plastic sheet
Physical Equipment	IRX 2.1 Board Microchip PIC16F84 Device Two gold pins Zinc-Aluminum Resistance pH Meter Analog Device AD22100 Temperature Sensor Standard Foil Uni-axial Strain Gauges
Software Application	Macromedia Director 8.5 CCS PIC C Compiler
Communication	Connect via RS-232 and a cable to computer serial port

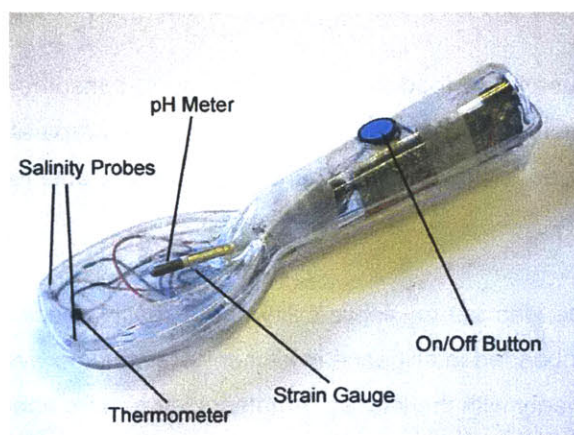

**Figure 13.** The intelligence spatula, with sensors labeled.

The shell of the spatula, as seen in figure 13, was plastic. The form of the spatula was taken from an ice-cream spade, and was molded from 3/32" PET plastic sheets using the vacuum former, found in the machine shop of Media Lab. The spatula had sensors for salinity, temperature, acidity, and consistency. The salinity sensor consisted of two gold pins installed on the surface of the spatula, and salinity was determined by the electrical conductivity between the two pins. The pH probe was borrowed from a garden pH meter, which is made out of aluminum and zinc, and acidity was again measured by the electrical conductivity between the two metal surfaces. The

temperature sensor was a readily available product from Analog Device, and was a voltage output ratiometric sensor. Consistency sensors were made out of strain gauges, which calibrate the stress experienced by each side of the spatula; the strain gauges were of general purpose, and have a resistance of 250 ohms when there was no stress.<sup>8</sup>

The original software was rudimentary; essentially it showed a picture of a saltshaker, and the picture increased in size as the spatula sensed more salt. There was no reference to the salinity of tap water, so the user could not tell how much salt there was in the solution compared to no salt. This application, nonetheless, demonstrated that the spatula is indeed sensing.

Since then, we have implemented another software application to teach users how to prepare brine for making pickles for the Fall Sponsor Meeting in October 2002. The application read from the salinity probes, and determined if the liquid is salty enough by measuring its conductivity. It had a picture that shows a plate of pickles; the pickles changed their color gradually from purple, to brown, to green as more salt is added into the liquid. This interface intended to show a user what the final product would be like if the cucumbers were being preserved in the solution measured; if the user dipped the spatula into tap water or a very weak brine, the pickles on the screen would be purple; if the brine was strong enough, the pickles would be yellowish green.

Pickles are chosen because it is a food that people commonly consume but have little idea about how to make. The demonstration was intended to demystify the preparation of pickles, and at the same time show off the idea of how the Intelligence Spatula was able to sense food and teach a user how to cook.

The goal of this prototype was set on applicability and a reality check of the idea of a sensing utensil. It showed that embedded intelligence in kitchenware can improve the cooking experience of people who have familiarity with the kitchen. Amateurs learn more about a recipe by following a detailed set of instructions that aids them in acquiring requisite intuition in cooking, while professional cooks find a handy tool capable of giving quantitative benchmarks and suitable guidelines, whose design can be swiftly incorporated into their cooking routine.

---

<sup>8</sup> The sensors used are available at the following sources:  
Temperature sensor – AD22100 by Analog Device, available at <http://www.analog.com/>  
Acidity sensor – Rapitest pH meter, No. 1840, by Luster Leaf Products Inc., available at ACE hardware, <http://www.acehardware.com/>  
Strain Gauges – by Vishay Measurements Group, available at Intertechnology Inc., <http://www.intertechnology.com/>

Apart from the salinity sensor, feasibility tests on other sensors were also done in this prototype. The temperature sensor was a commercial product, so we only needed to map out its resistance response to respective temperatures. In the process, however, we discovered that the upper limit of the functioning temperatures of the transducer was too low – it can only operate in temperatures below 150°C, or about 300°C, which limited the use of the spatula in low temperature cooking. This prompted a search for a new temperature sensor. For the acidity sensor, we used a component from a soil acidity meter, which is a probe made out of zinc and aluminum. Two tests needed to be done: the functionality of the probe after it has been taken out of the original equipment, and its sensitivity. Our tests indicated that it is functional and sensitive enough to be used in food.

The design of this prototype was not flawless. In fact, many aspects are far from complete, and this confines the spatula's usage to only one or two carefully constructed scenarios. To mention a few of the weaknesses:

- The original casing was made out of thermoplastic, which deforms as when heated<sup>9</sup> and was brittle when chilled; the operational temperature range was too narrow for the spatula to be used under typical kitchen circumstances. It was manufactured in two pieces, and the top and bottom pieces were fabricated in a rudimentary fashion, in which the junction cannot be sealed. The electronics housed inside the spatula were vulnerable to damages from water and food spatters.
- Although all sensors were physically present, the spatula was only able to measure salinity due to limitations in the circuit board configuration and software application.
- The encased circuit board was large, causing the handle to be oversized and was uncomfortable for a normal-sized hand.
- The spatula communicated with the computer via a phone cable, which tangled up frequently and restricted the movement of the user.

The problems rendered the prototype ineffectual. To further test the practicality of a sensing spatula and explore its potential application, a new prototype needed to be made.

---

<sup>9</sup> The exact material used for this prototype is undocumented, so the precise temperature when it starts softening cannot be found. However, when the spatula was briefly immersed in hot water of 90°C during preliminary testing, the plastic softened up and failed to hold its shape.

## **SECOND PROTOTYPE**

Learning from the previous attempt, there are numerous concerns in the designing the new prototype. These are the most pertinent:

**Durable material:** Although molding is facile, thermoplastic is too temperamental as a material for utensils. Ideally, the new spatula would have high temperature and chemical resistances and good tensile strength.

**Miniature circuitry:** With the circuitry embedded in the spatula, the electronics must be craftily designed to minimize the space necessary to bestow them. With fabrication technology available nowadays, the unelaborated circuit can be manufactured into minuscular size.

**Extendable software:** The Macromedia Director presentation is effective in showing one instance of application of the spatula and can be programmed rapidly. However, the inherent design of the Lingo language lacks flexibility, and is not a desirable language for programs that needs to be updated over time. The programs written in this language are slow to execute, and have limited ability to inter-operate with other systems. In the long run, it would be advisable to rewrite the software application in one of the general purpose programming languages.

**Aesthetics and Ergonomics:** Though irrelevant to its functionality, the look and feel of the spatula makes a first impression to its potential users. To encourage users to experiment with the spoon, it should be attractive and inviting, and yet have a modern, futuristic touch that distinguishes it from an everyday spatula. The original prototype was transparent, which welcomes its users to explorer its internal configuration; however, its design was unpolished and deviates drastically from ordinary utensils, which could be intimidating for first-time users. The spatula should be easy to hold in hand, and the head should be of the right size.

To achieve this goal, every detail of the spatula has to be meticulously attended to, and the process was reiterated many times. There were numerous discussion sessions on the topic of kitchen utensils design between myself, Ted Selker, and Barbara Wheaton. Many different models were rendered either as CAD drawings or physically created using clay or 3D printing, with the help of Leonardo Bonanni. Figure 14 shows two initial designs, as presented in AutoCAD.



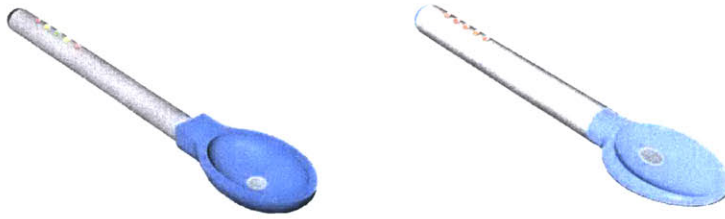

**Figure 14.** Different designs have been considered. The one on the left is the first try; it has a deep bowl, and a thin handle. The right one is an improved version of the first one; it is flatter, and has a thicker handle that fits better into the user's hand.

The remake of the spatula goes three ways: casing, circuit board, and software application. Details for each part are discussed in the sections that follow.

## **CASING**

For the casing, both the material and the form are within the bounds of consideration. When contemplating the new design, the central question is “what makes a good spatula?” We examined many spatulas being sold on the market that are of vastly different shape, and read the opinions on them<sup>10</sup>. Users highly value the following several aspects of design in a spatula:

- **Ergonomics:** Many details attribute to the ease of use in the design of a spatula. The spatula's balance and handle design must provide a comfortable grip, and the handle should be long enough for the hand to be away from the heat of the stove. The shape of the head should allow the cook to easily scrape bottoms and edges.
- **Taste:** The material should be inert and nonabsorbent, to ensure that the food is not tainted by flavors from previous dishes when it was used to cook curry or salsa, or by the material of the spoon.
- **Safety:** At the minimum, the head should fit securely into the handle. It should be of sturdy construction and should hold its shape during heavy beating, mixing, and lifting. Preferably made out of materials that are poor conductors, the spatula should react slowly to sudden changes in temperature to protect the user's hand from burning or frost bites. The surface should be bacteria and mold unfriendly and dry quickly.

---

<sup>10</sup> Few books dedicate itself to kitchenware. Among them [WAF00] were the most frequently referred to during the design process; it gives a professional, authoritative point of view on many exemplary kitchenware designs and specialty utensils. To get a broader view from actual users, various online discussion forums, including Epinions (<http://www.epinions.com/>) and Amazon.com (<http://www.amazon.com/>) were also used.

- **Ease to clean:** Ideally, the spatula should be dishwasher safe. If hand washing is required, it should be free of absurd corners that cannot be reached and the surface should be of a material that does not hold on to food scrapes.
- **Aesthetics:** Apart from the functionality, a good spatula should be pleasing to the eye. A spatula should be able to maintain its shape and color over time as well. Spatulas that get scuffed, splintered, rusted, stained, and yellowed over time are inferior to their longer lasting counterparts.

One rendition is shown in figure 15. It is made out of ABS plastics, and is 3D-printed.

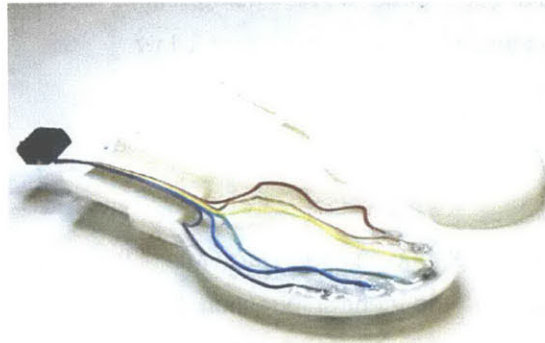

**Figure 15:** A 3D-printed model of the final design. Holes were intentionally left to allow rooms for sensors to be attached.

Apart from the fore-mentioned criteria, we are also interested in creating a general-purpose sensing kitchenware, instead of simply a spatula, that can serve as multiple utensils with only one piece of electrical hardware. Figure 16 shows a handful of clay models that we worked on. Although the concept of integrated kitchenware is intriguing, we feel that it is premature to expand the research into this realm at this stage, and thus this attempt was not followed through.



**Figure 16:** A model of the fork-spatula. The sensors will be embedded into fork, and the flap can be attached to the lower part of the fork and convert it into a spatula.

After going through this process several times, we finally settled on a design that draws a good balance between all the criteria discussed previously, as shown in figure 17.

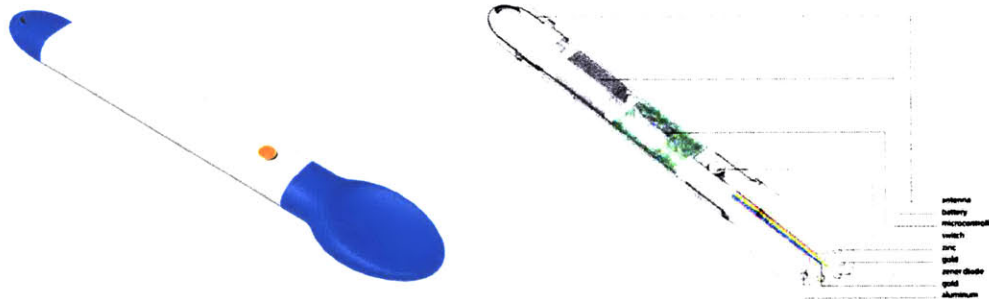

**Figure 17:** Final design of the spatula and a see-through rendition of the interior.

Certainly the design is incomplete without a choice of material. In the real world of kitchenware, there are only three that dominate the realm of spatula material – stainless steel, wood, and plastic. To apply the previously mentioned design guidelines into the choice of material, the material should be easy to clean, heat and chemical resistant, sturdy, and waterproof to protect the electronics embedded.

Many kinds of materials have been explored. These are the analyses of a short list of candidates:

**Plastic:** The first prototype proved polyethylene to be futile as a kitchen utensil material, but it does not rule out plastic as a possible material for the new spatula. There are two types of plastic – thermoplastic and thermoset. PET is a type of thermoplastic. Thermoplastic is made soft by heat, and then becomes hard when cooled. It can be readily molded into different shapes by applying heat, but this was proven to be undesirable in the first prototype.

Another type of plastic made out of a different polymerization process, thermoset plastic has a much higher heat tolerance. Once it is formed, it cannot be melted and reformed. However, the complexity in processing and forming the plastic far exceed its benefits, and would severely delay the prototyping process.

Plastic has been seriously considered in the design as the material for the new spoon. As previously shown in figure 6, the final design has been 3D-printed. This spatula, made out of ABS plastic, has excellent electrical properties, and resists inorganic salts and many acids. However, due to its high rigidity it is hard to completely seal the joint at the head without using sealants, many of which are toxic, rendering this particular spatula impractical.

Apart from the concerns about its heat resistance, many kinds of plastic are chemically active, and may even be poisonous, and this forces us to explore other materials.

**Glass:** Glass has exceptional heat tolerance, is chemically inert, can be molded into many shapes, and looks beautiful. However, it is too fragile for a spatula, and requires a furnace and exceptional blowing skills to shape into form.

**Stainless Steel:** Stainless steel also has good heat endurance, and is sturdy; nonetheless, it is hard to shape and its good electrical conductivity makes it difficult to place electronic parts in the spatula.

**Porcelain:** Porcelain is stronger than glass and is easier to shape than stainless steel. Its heat and chemical resistance make it suitable for many kinds of food; however, most furnaces are designed for pottery and the abnormal shape of the spatula makes it very hard to fit into a furnace for firing.

**Silicone:** A synthetic polymer, silicone rubber is formed by the process of vulcanization that gives the material its unique properties. Silicone can withstand a wide range of

temperatures<sup>11</sup> and has exceptional tensile strength and flexibility, which makes it perfect for use in kitchenware. It is fairly convenient to cast and the mold can be made out of a wide variety of materials. Additionally, many types of silicone are odorless and tasteless, do not support bacteria growth, will not stain or corrode other materials, and are formulated to comply with FDA regulations. They have been used in making various kinds of cookware that are currently sold in stores<sup>12</sup>.

Among the different materials analyzed, silicone is the most versatile and moldable; however, silicone rubber does not make a good handle because of its flexibility. The handle should be constructed by an impliable material. After several modifications, the spatula now consists of a 3D-printed handle and cap as shown in figure 18(a), which is unbendable, and a silicone head.

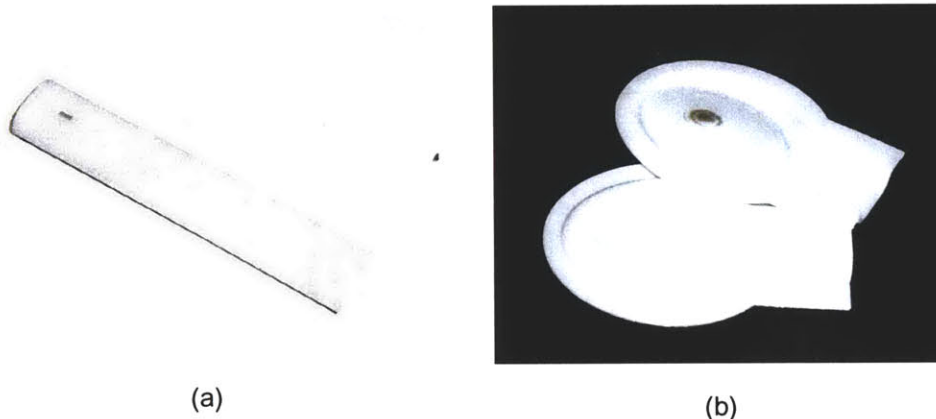

(a)

(b)

**Figure 18(a):** The handle of the spatula.  
**Figure 18(b):** The mold for silicone casting.

To cast a silicone model, a mold has to be made. Figure 18(b) shows the mold we used for casting the spatula. The mold is constructed by the process of stereolithography, and is a negative of the spatula shown in figure 15.

To embed the sensors into the head of the spatula, they must be put into the mold before the model is cast. To improve the aesthetics of the prototype while retaining the artistic touch, all sensors are either made directly out of metallic disks, or hid underneath one. The photo in figure

---

<sup>11</sup> Depending on the type of polymer, the operational temperature of silicone ranges from -100°F to 750°F. The particular type used in the spatula is viable from -50°F to 650°F.

<sup>12</sup> Silicone cookware is expanding its presence in many stores. For example, Crate and Barrel is selling a spatula that is made out of silicone, and Amazon.com carries silicone cake mould that can be used in conventional ovens.

19 shows the contacts before they are embedded, and is taken from the back. The contacts are color-coded with a cable, allowing easy matching of the appropriate electronics to the respective sensors. To accommodate the look of the new prototype, some sensors has been altered:

- Salinity – Two gold-plated aluminum disks (gold leaves to be adhered after the silicone model is entirely cured).
- Acidity – An aluminum and a zinc disk.
- Temperature – Glass-encased zener diode, on the back and in direct contact with an aluminum disk.
- Consistency – Two strain gauges, attached to the front and back of the cable, approximately 1.5 away from the temperature sensor.

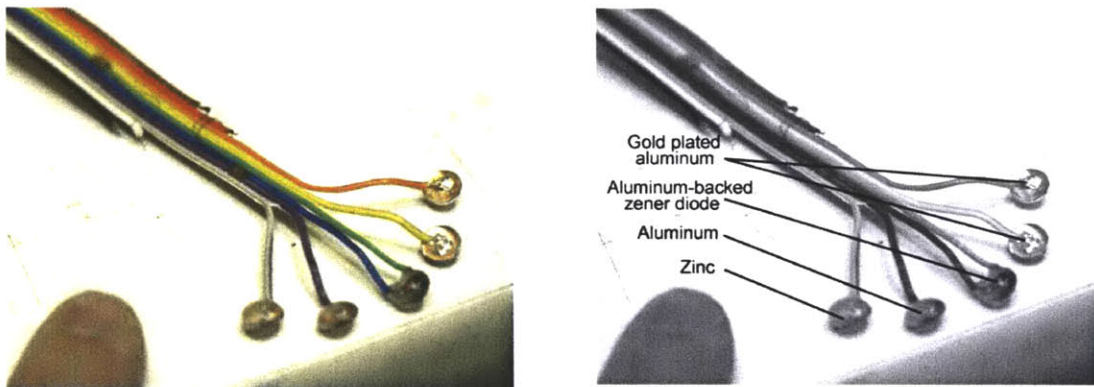

**Figure 19:** Contact sensors. The picture on the left shows the sensors as seen from the interior of the spoon; as it can be seen, the respective contacts are color-coded using a 12-wire cable. The one on the right is the contacts with annotations.

Before pouring the rubber into the mold, the sensors are put inside the mold and the contacts are slightly glued to the side of the mold to prevent dislocation when pouring. The filled mold is then placed in the fume hood for the silicone to cure. Curing time varies from one type of silicone to another and is also affected by the temperature when curing. The blue type, as shown in figures 20 and 21, takes around 3 hours to be fully cured in room temperature.

After the silicone is cured, it is detached from the mold. Figure 21(a) shows a final product of our first attempt. The blue silicone hides the wiring of the sensors, and makes the spatula less story telling than a transparent one; therefore, another spatula was cast, this time with a transparent type of silicone, as show in figure 21(b).



**Figure 20:** Filled mold in fume hood. The cramps hold the two pieces of the mold together while the silicone is curing.

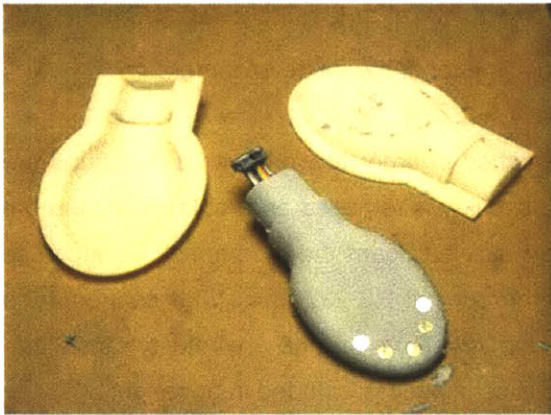

(a)

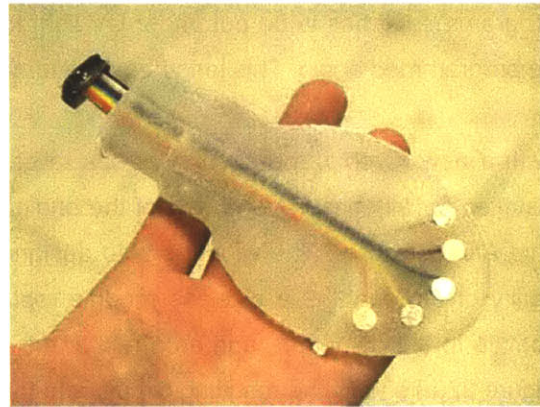

(b)

**Figure 21:** Finished products of the two attempts. (a) shows the spatula from the first casting. This attempt is considered a failure because of two reasons; first, the silicone is too soft to make a lasting spatula; and the blue color masked the interior wiring of the sensors, and is less compiling than a clear one. (b) is the clear spatula resulting from the second casting.

## **HARDWARE**

The original hardware can accommodate at most 4 sensors to be used at the same time. The integrated circuit (IC) chip chosen does not have an analog-to-digital converter, and although this deficiency can be remedied by manually implementing a R/C circuit to mimic the on-chip A/D converter, two physical I/O ports are required for each sensors to measure the time taken for charging up the capacitor. The chip itself has 13 I/O ports; however, since some of them are assigned for use in the LED, IR, and serial output, only 8 physical ports are available, which can

only read from 4 sensors. The software was unable to communicate with some sensors, and we had to compromise some functions in order to use others. Changes to the circuit board configuration and to the selection of the IC chip must be made in order to utilize all of 5 sensors in the previous prototype.

We decided that another model of IC chip must be used for the new spatula, to evade the issue of insufficient I/O ports. The challenge was to find another chip that is compatible to the iRX protoboard – iRX has many desirable built-in features that reduce time in designing a new circuitry, and is the preferred protoboard for the spatula. Eventually, we chose the PIC16C711 from Microchip. Four I/O ports are connected to the on-chip A/D converter, which means that for the sensors hooked up to these ports, they only occupy one physical port each. This essentially increases the number of readable sensors from 4 to 6, which is adequate for the spatula. The only drawback with this chip is that it uses CMOS EPROM, instead of EEPROM; once a chip is programmed, it has to be put under UV light for 10-20 minutes to erase the content before it can be programmed again. This lengthens the turnaround time for firmware development.

With a new IC chip, the circuitry needs to be redesigned in order to work with it. Hookups are installed for all sensors, and part of the original RC circuitry is removed and replaced by the on-chip A/D converter. The wiring is also designed to make the board more compact. To increase agility of the spatula, a wireless module replaces the original RS-232 cable that connects the spatula to the computer, and as a result, the new circuitry has to include a wireless transmitter. Figure 22(a) shows the resulting circuit, and the circuit schematic is included in appendix D.

To receive the wireless signal from the spatula, a corresponding receiver module has to be constructed and be connected to the serial port of the computer. In this wireless module, we chose Linx technologies' LC series for its compact package, low cost and power consumption, and direct serial interface. The transmission range of the wireless pair, which is around 10 feet as tested in the kitchen of Counter Intelligence, is satisfactory for use in a spatula, as ordinary users are unable to read the computer screen if they are more than 10 feet away.



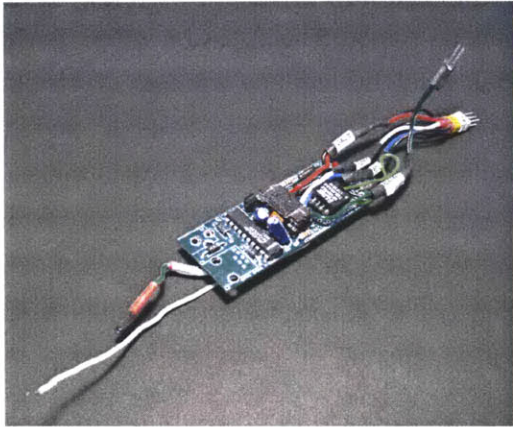

(a)

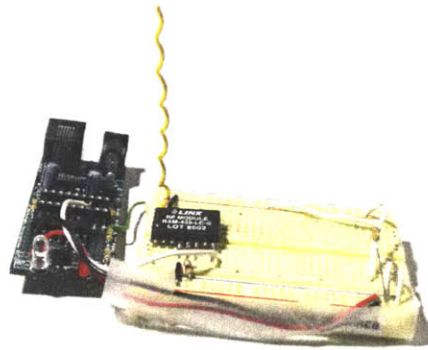

(b)

**Figure 22:** Photos of the circuits. 22(a) shows the iRX board that is placed inside the handle of the spatula. 22(b) shows the receiver that is connected to the computer.

## SOFTWARE

The original software was made in Macromedia Director, and, as discussed previously, had very limited functionality and speed. To remedy this, we used Java to develop a new software. The software reads from the serial port, processes the data, and presents the information to the user.

From a user's perspective, the software displays a breakfast menu with pancakes, waffles, and scones. If the user selects any of them with a mouse, the recipe of that food is shown, with a checklist of ingredients and procedures. The user can then use the spatula to stir in and mix the ingredients, and when he adds a particular ingredients that changes the concerning properties of the mixture, the spatula starts measuring the content of the food and checks off the ingredients automatically when the right amount has been added.

Currently, the software is only calibrated to work on pancakes. Once the user clicks on the pancake label, the window refreshes itself to show the recipe of pancakes. The recipe consists of three sections – a checklist of ingredients, the mixing part of the procedure, and the cooking part. For the most part, the user has to mentally check off the ingredients after he has mixed it into the mixture; however, there are two ingredients that the spatula is constantly monitoring – salt and baking powder – by measuring the salinity and acidity of the mixture<sup>13</sup>. The software not only knows that they have to be added to the mixture before cooking, it also knows what amount should be added and checks off the box for salt in the list of ingredients if that amount is added.

---

<sup>13</sup> Baking powder is basic, so when it is added into the mixture, it changes the acidity.

Say if a user has mixed all the ingredients except salt, and thinks that he is done and tell the software so by clicking on the “Done mixing” button on the screen. The software, which gets the salinity and acidity readings from the spatula, can analyze the mixture and discover that the salt level is low. It then plays a voice message (“Salt please.”) to remind the cook about adding salt. As the salinity goes up as salt is being added, the software would play another voice message (“Thank you for salt!”) and checks off the box for salt, without human intervention, when it reaches the appropriate level. The scenario for baking powder is similar. In case the user forgets about both salt and baking powder, the missing salt is brought to attention first before the baking powder. Screenshots from this scenario are attached in appendix E.

The application is made up of two main classes – ConnectionManger and SpoonFrame. ConnectionManager deals with the serial port connection; this includes opening and closing connections, getting data from the serial port, and vectorizing the serial data for further analysis by other modules. The data is then passed onto SpoonFrame, which is responsible for analysis of the data from the spatula and user interaction. It contains all the graphical elements, action listeners, and a monitoring module. The graphical elements are for displaying results and other outputs. Action listeners monitor any user activities from the keyboard or mouse, and trigger other modules to respond to the input when necessary. The monitoring module plays an important role in understanding the data from the spatula. The raw data from the spatula contains mistakes occasionally, due to the hostile environment it could be in, and needs to be normalized in order for the software to give sensible suggestions; this is done in the monitoring module. Apart from that, it searches for patterns in the data and extrapolates the user’s actions, and forewarns the user of possible pitfalls and dangers. Detailed documentation of the application is attached in appendix C.

The setup for the new prototype is summarized in table 2.

<b>Table 2. Specification of Current Intelligent Spatula</b>	
Material	ABS plastics handle; silicone rubber head
Physical Equipment	IRX 2.1 Board Microchip PIC16C711 Device Two gold-coated aluminum disks for salinity Zinc and Aluminum disks for acidity Glass-encased zener diode for temperature Two standard Foil Uni-axial strain gauges for viscosity
Software Application	Java 2 Platform Standard Edition v1.4.1 CCS PIC C Compiler (on-chip firmware)
Communication	Serial wireless connection Linx RXM-433-LC-S (receiver) and TXM-433-LC-R (transmitter)

## **SYSTEM INTEGRATION**

The most difficult part of the project lies in the integration of different parts built previously. Often times we have to foresee how the modules interact, and to make provisions for one part of the system in another. In our initial design, for example, the on-chip firmware was supposed to normalize the data before transferring it to the computer, but the memory space and processing power is severely limited on the chip we selected, and the computation can be done more efficiently on a PC. In the end, the normalization process is moved to the software application on the PC and raw data is directly transferred without any processing. The original design of the spatula does not include an external antenna, nor does it have space for one. However, after the wireless module was implemented, preliminary testing revealed that the plastic of the handle is an effective signal barrier and an external antenna is necessary to ensure reliable transmissions. To accommodate this, the cap of the handle is modified to allow a wire antenna, which is directly connected to the transmitter, to go through the casing.

Because the function of components are so intertwined, design decisions made in one part of the system often change the design in another. The decision to use iRX as the protoboard was meant to speed up the process of prototyping, but posed a challenge on the design of the casing. The board contains many extra features that are not utilized in this project, but the features increase the sheer volume of the board and are difficult to fit into the tight space of the handle. To hold the iRX board and still retain its comfortable size, we flattened one side of the handle while widened another so the cross-section is oval-shaped, instead of round, as in many previous designs.

## **DEMONSTRATIONS AND EVALUATION**

Many demonstrations of the spatula were given to sponsors and media outlets, and we were encouraged by their responses. They were amazed by how simple the idea is and yet how much impact it could have in a conventional kitchen. As detailed in earlier chapters, computers, sensors, and electronics generally receive very negative judgments when applied to kitchenware. However, when demonstrated that the intelligent spatula can teach how to make a specific kind of food, people became very interested and enthusiastic about it. The more they see, the more they would like to use the spatula and be involved in the process of creating recipes. In fact, during a demonstration on Good Morning America, the understanding that Diane Sawyer had of the spoon was simply a three-minute discussion before she wanted to use it herself.

The spatula is functional and demonstrates its capability to people, but its operation is not bug-free. The real-life testing during demonstrations reveals the shortcomings of chemical analysis

method used by the spoon. For example, to test the conductivity of a food requires the food to be in liquid or paste form, but not all foods are soluble so it can only be used on certain recipes or when the ingredients are added in certain order. For example, in our pancake recipe, we have to add the dry ingredients individually into the mixture of milk and butter, while the usual practice is to mix all the dry ingredients first, and add the milk afterwards. Even so, there are problems with flour lumps clogging the sensors, causing the spatula cease to sense. The response time of the chemicals in the food also tends to be long, which gives a false impression that the sensors are slow when, in actuality, the chemical reactions have not taken place yet and the sensors are simply waiting to register them.

On the other hand, the spatula reveals deficiencies with the cooking techniques of some cooks. Several users, when making pancake batter, care less about mixing the batter well enough to moisten the flour, and there are big lumps of flour in the mixture. The salinity and acidity contacts are unable to conduct, causing the application to complain about the missing salt and baking powder even when they are present. The error message is obviously inappropriate, but it points out a critical flaw of the user, that is, not mixing the batter enough. This illustrates yet another potential usage of the spatula for the more experienced cook – to help them improve their cooking skills. To give a better suggestion, the consistency sensors can be used to determine the thickness of the batter and the spatula can judge that the batter is not adequately mixed.

After the remodeling, the spatula was tested against usability heuristics [Ni93], and also a few actual users. We noticed a few pros and cons of our design shortly after the spatula was put to real use, and below is a list of the most obvious ones.

#### Advantages

- Excellent heat and chemical resistance
- Small and sensitive sensors
- Good maneuverability

#### Disadvantages

- Soft head makes scraping difficult
- Handle is too large and heavy

At the time of this thesis' submission, we are preparing for a formal user study of the Intelligent Spatula. The study involves asking users to perform cooking tasks with the spatula and without, and they are asked to make dishes involving different kind of measurements. After the cooking session, they are interviewed and asked about their experience. The primary questions that we were interested in are:

- How long does it take for a person to complete a recipe with and without the spatula?

- Does the user express joy, frustration, or discouragement when cooking with and without the spatula, and how often?
- What percentage of users actually completes a recipe when working with and without the spatula?
- Is the food, in terms of chemical content, closer to that in the recipe with the spatula?
- What are the user's general reactions to the spatula?

Many aspects of the spatula had been carefully pondered on during the design of the new prototype, but it is imperfect nevertheless, given the time pressure we had in adhering to deadlines and giving demonstrations. As more demonstrations are given and more users are involved in the evaluation process, we observe the spatula in action and gain better knowledge about various aspects of the project. Here are topics we would like to explore in the future:

**User Interaction:** The simple display in the original prototype, and how effective it was, lead us to rethink what mode of interaction with the user the spatula should be using. For the second prototype, we considered the option of installing a set of LED lights with different colors on the handle of the spatula and delivering all information through the lights instead of the computer screen. However, given the time constraint, it is difficult to devise a LED display scheme that allows the users to get the food information effectively without spending a substantial amount of time in learning the scheme, so, finally, we choose to use the computer screen because it allows us to display data in a more intelligible way.

Though we did not pursue the path of an on-handle display, the option is still worth exploring. It gives users better mobility, for they are not bound to the readable range of a computer screen. Also, ergonomically, this is more convenient as users get all information by looking at the handle instead of turning their heads to search for the screen. Considerable drawbacks are limited screen space, power consumption, and low versatility to display complex information. All in all, this is an attainable goal but only with significant amount of research.

**Transparency of the system:** Although we believe that the new prototype is more desirable than the original one, people are more attracted to the original prototype, because of the fact that it is completely transparent and allows them to explore the internal circuitry and wiring. We did not realize this until the new handle was made out of white, opaque plastic, but it prompts us to reexamine what quality of the spatula aroused the interest of new users and build up their trust in this foreign device. From our

conversations with several people, who have various levels of familiarity with electronic gadgets, a recurring theme is transparency. The more transparent a system is, the easier it is for users to understand. As this understanding deepens, so does their trust in the system. We can draw many similarities between this and our experience when demonstrating the spatula to many sponsors. Some of them were initially skeptical about the spatula when they first heard about the idea. Nevertheless after we explained the chemistry of food and how the spatula takes advantage of this to assist users, they agree that the spatula is a worthy endeavor.

To further improve the impression given by the spatula, we need to focus on increasing the transparency *of the system*, instead of just the handle or the hardware. A possible solution is to add a tutorial to the software to explain the mechanisms employed by the spatula to measure the different properties and various parts that compose the spatula.

**Space saving circuitry and space saving handle:** The handle of the spatula, we believe, is still too thick and is certainly too heavy. It is limited by the size of the circuit board and the weight of the battery. To further reduce the size of the circuit we need to build a custom board instead of using a general-purpose protoboard as iRX. To reduce the weight we need to research on lightweight batteries that can supply enough power for the circuitry to last through a few recipes, which is typically a few hours.

**Compensating a sensor with another:** As mentioned in chapter 2, some readings are correlated, or a change in one property can affect the sensors of another. Salinity and acidity are interrelated because they are both measuring the conductivity of the food, and a change in salinity affects the readings from the acidity sensor. This, however, can be compensated by carefully correlating the effects salinity has on acidity sensors, and counterbalancing this effect at the firmware or software level. A similar problem exists between temperature and the strain gauges and can be solved by using dummy gauges that are placed in orthogonal, or again, by compensating the effect in a higher level of processing.

**Extendibility of recipe database:** One advantage of involving a computer in the spatula instead of embedding all intelligence into the spatula is that it is easier to upgrade the software and the sources of recipes on a computer. The recipes, however, are hard-coded into the software at this time that defeats the original spirit of extendibility. Ideally, the software would use an easy way to incorporate new recipes, such as querying data from a database. Barbara Wheaton, a food historian in Counter Intelligence, has been

working on a food database for over 3 years, and as a first step the software can be modified to be able to communicate with her database. Further extensions would be parsing recipes in forms of XML, so that the user can download recipes from the Internet, or interfacing with the Essence of Food, another project in CI by Hugo Liu and Ted Selker that analyzes many recipes to pinpoint the essence of a dish. With these integrations, users get more recipes that are more reliable.

**Integration with other technologies:** The spatula would be more useful if it could collaborate with other technologies in the kitchen. As a starting point, one could integrate the Intelligent Spatula with other projects in CI. For example, Wendy Ju built an active countertop with a taufish array sensors, called CounterActive. The array reports information about weight changes or pressure on the surface. Software is built to utilize this capability and guides a user through the steps of a recipe and teaches them how to cook. If working with the spatula, the computer would have information from both the spatula and the countertop that enables it to make succinct recommendations that are more pertinent to the user's actions.

The spatula can also be used in another project, Minerva, to aid its accuracy in object recognition. Minerva is a perception based cooking assistant with a camera and a touch screen. The system works by taking a picture of the food placed in front of the camera; it then recognizes the food in the picture, and makes suggestions on the dishes based on the ingredients available. Any object recognition system is bound to err, but with the spatula, any error can be detected easily. For example, if the system mistakes a tomato to be a zucchini, the spatula would be able to tell because zucchini has a much higher pH.

With this kind of integrations, the spatula can be an individual tool, or a component of a bigger project with other intelligent tools for a more connected kitchen.





## CHAPTER 5. **CONCLUSION**

Although the Intelligent Spatula has scarcely scratched the surface of what intelligent cookware will be able to do, it is evident that this is the beginning of something larger. This thesis suggests new ways to think about ingredients' chemical properties, and how to harness this knowledge and incorporate it when designing kitchenware. The Intelligent Spatula project demonstrates the practicality of intelligent kitchen tools and sheds light on its design principles. In this section I review our perspective on food chemistry, the design principles we follow, lessons on design learned during the process, and conclude by speculating the future possibilities in this area of research.

### **FOOD CHEMISTRY REVISITED**

In the process of assessing the feasibility of Intelligent Spatula, we thought about different methods to evaluate ingredients' chemical and physical properties, often in a non-conventional way. In order to develop a context-aware system that teaches cooking, it is imperative for the computer to understand the food it is supposed to cook and the actions of its user, by analyzing the chemical content of the food. The first step is to devise a quantitative system to describe the various aspects of food, especially the ones frequently referred to when cooking. Temperature has the most obvious and widespread use and can be conveniently expressed numerically. We strived to develop a similar system for several other properties and our work succeeded in finding a new way to talk about salinity, acidity, and consistency. Instead of tasting with the tongue to determine salinity and acidity, in our system, both are re-defined as conductivity, with salinity being that between two pieces of metal of the same type, and acidity, two different types of metals. Consistency, which is typically described in a qualitative, unscientific language ("if the content seems thick, add more milk", "add water until a paste is formed"), is viewed as the pressure exerted by the food onto the two sides of a spatula when stirring. As there are well-

established systems to measure and express conductivity and pressure, the findings reduce our work to the integration and calibration of these instruments.

Beyond the design work, when developing scenarios and new ways to use the spoon, we again made a point of evaluating different ways of thinking about the ingredients' chemical properties. This time, our focus is on finding the chemical properties of different food as seen by the spatula, instead of ways to evaluate them. Through this process we defined several axes along which one could decide to use such a spatula. It is obvious that the spatula cannot tell everything about a particular recipe, but it can exclude certain recipes by nature of the situation. For example, if a dish is acidic and contains milk, it is likely to be thick because the milk curdles. If the recipe suggests the user to use this as the base of a soup or a sauce, the spatula can remind him to check the recipe to ensure its correctness.

By using models of cooking and food, the spatula is in a position to understand what kinds of food can or cannot be made based on its sensors uses. Chocolate cannot be mixed or stirred if the temperature is lower than its melting point, which is around 80°F to 120°F. Chocolate milk, on the other hand, could be stirred, but that is a very different thing. This kind of analysis is a focus for creating a more successful, sophisticated spatula that can understand food well enough to be able to use common sense to help people in cooking.

## **DESIGN PRINCIPLES FOR INTELLIGENT KITCHENWARE**

The philosophical underpinnings for designing intelligent kitchenware are simple, but regard of these principles can greatly reduce the number of iterations needed to reach a successful design and enhance overall user experience. Some of them bear resemblance to the usability heuristics suggested by Nielsen, but go beyond these to incorporate principles that governs physical input devices and kitchenware design.

- **User control:** To truly enable the user, the tool should allow the user to set the direction and pace. Be sure to pick the right tool for the task.
- **Feedback:** Prompt feedback acknowledges user actions, allows them to gauge their performance quickly, and engages them in the process. In an environment as dynamic as the kitchen, instantaneous feedback is often necessary to avoid irreversible damage and to allow accurate performance evaluation. Feedback should not be limited to visual or audio output; other modals may be more convenient in different situations [AS03]. Choose the appropriate modal depending on what the tool is trying to communicate.

- **Adaptability:** Versatility of a tool allows it to be used under many circumstances, and yield more for the effort spent on design. The tool should also be able to adjust itself to the environment in which it is being used, and never be the center of universe that the environment and user revolve around.
- **Coherency and standards:** Inertia is part of human nature, therefore the more familiar the tool looks, the easier it is to get people to use it. Use jargons that are customary to the kitchen; take shapes that are common to most kitchenware, and if there are standards governing a particular tool, conform to the rules sensibly.
- **Transparency of the tool:** The need for an “invisible” tool that does not overshadow the cooking process and the need for the tool to communicate clearly with the user creates a tension. To achieve both ends, the designer needs to strike a balance in the “translucency” of the tool.

The principles mentioned are not intended to be steadfast rules, but rather, guidelines and details a designer should pay attention to when envisioning the appearance and user interaction of a product.

## **IMPLEMENTATION GUIDELINES**

Apart from guidelines regarding the design aspect, we learned that the process from the conception until the realization of the idea contributes significantly to the final product. The building of the Intelligent Spatula reveals as much about the process of the design as it does about the potential of intelligent kitchenware. Here are a few process guidelines that underlie the designs of this thesis:

- **Start building soon and build frequently:** Thoughts on requirements, ergonomics, and other issues are important, but rather than rendering all designs in software or on paper and building only a final product, it is imperative that the designer starts building dummies or markups once there is a preliminary design. The building process reveals any unnoticed flaws, and the dummy provides a basis for realistic, in-depth discussions of the pros and cons of the design.
- **Keep up with the trends:** Understanding a wide variety of technologies and other innovations allows designers to employ them in their own work. With a deeper

understanding of the capabilities and limitations of these tools, designers can use them in creative ways and push their development in new directions.

- **Be human-centric:** The needs, behaviors, and expectations of people serve as a good starting point for designers. Analyze what users want, how they work, and what they lack. Be sure to take into consideration their physical movement in space and their interaction with other objects in the kitchen.
- **Use all tools in the arsenal:** The design of the intelligent spatula draws from a wide array of media, from kitchenware design and mold casting to circuitry design and code. It is vital that the design of intelligent cookware is driven by the needs of the applications, not the limitations of the designers' expertise.
- **Be open-minded, but critical always:** Designing creative physical input/output devices requires designers to be curious, bold, and open-minded about any idea, but it also requires them to be discerning about different designs, and be on the lookout for any pitfalls.

As the process iterated itself during the design of the spatula, we were progressively dependent on the guidelines described above. As mentioned previously, these guidelines come from experience and we are certain that there are more to discover as the process sophisticates.

## **FUTURE POSSIBILITIES**

If we take a step back on the Intelligent Spatula project and look at smart tools as a class of emerging technology, we can see that like projects have immeasurable potential. On a smaller scale they can teach cooking but, as the accuracy of sensors improves and the public's trust in intelligent kitchenware deepens, this kind of tools can be used in a much broader application and be involved in more critical instruments.

Our original focus was on cooking and eating, and had developed many scenarios of how we can use the intelligent cookware to facilitate the cooking and dining process. For example, it is possible to borrow the idea and make a sensing pot that would warn the chef if the food is going to burn or a plate that can tell if the food is warm enough to serve. Naturally, this leads to the rumination of how people who do not cook can benefit from such technologies, which in turn raises this question – “why do some people never cook?” The reasons are diverse but we noticed that among those who do not cook, there is great inertia to start cooking for the lack of interest

and fear of failure. Most of the time, this is due to misconceptions about cooking. With an appropriate software application, the system can be used to target some particular groups of people who are usually stereotyped as bad cooks, such as dads, and encourage them to experiment with cooking. There are issues with finding the right ways to motivate these people, but the system can be used as an effective tool to provide them with the comfort and privacy of trying at home and the benefit of having a guide at critical times.

When showing the spatula to sponsors and others, they gave us a lot of fresh ideas about where intelligent cookware could lead, some of which we had never considered as a possibility. Some people think that the system can be a part of a health monitor. People with health conditions – or who are simply health-conscious – can use smart cookware to help monitor their nutritional intake. If a pot can tell how much it has in it, and a spatula can analyze the concentration of salt in food, together they help patients with hypertension to track their daily sodium consumption. This information can help physicians or software agents to recommend necessary dietary adjustments for improving their health. Some even imagined this kind of tool to become an aid to the handicapped. One person told us that a spatula of this kind would greatly help his wife, who is blind, in the kitchen to better understand her food while she is cooking. Talking kitchen tools are available now, but their passive nature, coupled by peculiar designs, is insufficient for real cooks that are blind. Instead of using a talking measuring spoon that tells them how much salt it contains, they want to be able to just sprinkle the condiment into their food and have an approximate idea about how much there is, as if visualizing the amount of salt added. With a context-aware pot or spatula that warns them when the salinity is getting close to a preset value, cooks without sight can mimic what we do every day. These scenarios are still remote now, but the problem is not a deprivation of the enabling technologies, but an incompetence of choreographing the necessary components into a complete ensemble of an integrated system.

It is our belief that artificial intelligence will eventually prevail in the household, just as what we have nowadays in office space. Meanwhile, possibilities for intelligent kitchenware abound. Intuitively, the Intelligent Spatula can evolve into an active fork, a smart ladle, or an intelligent pot. We believe, however, that the Intelligent Spatula itself is not as important as the implication this experiment has on the role of sensors and intelligence in the kitchen.

Sensors and artificial intelligence often receive skeptical comments when applied in kitchen, as discussed in previous chapters. In this thesis we proved that computer in the kitchen is limited by its form, not by its functionality. Computers are useful in the kitchen, but they must be innovative in its form of interaction with users, and the designers must be very careful about making incremental transition from the ordinary. The ability to put intelligence into individual pieces of

cookware enables a kitchen to be gradually transformed and gives ample time for cooks to adapt to new gadgets and ease the transition. In the end, computers, especially those in the kitchen, are not created to replace human effort but to aid them in cooking and allow them to enjoy the process more. The same technologies that enable a computer to act as an embodied servant to human beings should also empower users to achieve more and find more joy in achieving.

## APPENDIX A. **PANCAKE RECIPE**

Taken from "How to Cook Everything" by Mark Bittman (Macmillan, 1998), page 115-116.

### **Basic Pancakes**

*Makes 4 to 6 servings*

Time: 20 minutes

2 cups all-purpose flour  
1 tablespoon baking powder  
½ teaspoon salt  
1 tablespoon sugar  
1 or 2 eggs  
1½ to 2 cups milk  
2 tablespoons melted and cooled butter (optional),  
plus unmelted butter for cooking, or use oil

1. Preheat a griddle or large skillet over medium-low heat while you make the batter.
2. Mix together the dry ingredients. Beat the egg(s) into 1½ cups of the milk, then stir in the 2 tablespoons melted cooled butter (if you are using it). Gently stir this into the dry ingredients, mixing only enough to moisten the flour; don't worry about a few lumps. If the batter seems thick, add a little more milk.
3. If your skillet or griddle is non-stick, you can cook the pancakes without any butter. Otherwise, use a teaspoon or two of butter or oil each time you add batter. When the butter foams subsides or the oil shimmers, ladle batter onto the griddle or skillets, making any size pancakes you like. Adjust the heat as necessary; usually, the first batch will require higher heat than subsequent batches. The idea is to brown the bottom in 2 to 4 minutes, without burning it. Flip when the pancakes are cooked on the bottom; they won't hold together well until they're ready.
4. Cook until the second side is lightly browned and serve, or hold on an ovenproof plate in a 200°F oven for up to 15 minutes.





## APPENDIX B.      **ACIDITY AND TEMPERATURE**

The following list features a sample selection of common food and their pH.

Sources: CRC Handbook of Chemistry and Physics [Li03]

Approximate pH of Foods and Food Products [FDA00]

<b>Acidity</b>	<b>pH</b>	<b>Food</b>
High acidic	2.0 – 3.0	Fruit Juice
	2.0 – 4.0	Soft drinks
	2.2 – 2.4	Lemons
	2.5	Vinegar
	3.0 – 4.0	Wine
	3.0 – 4.0	Oranges
	3.1	Jelly
	3.3 – 4.5	Grapes
	3.5 – 4.0	Jams
	3.6	Ketchup
	3.7 – 4.9	Tomatoes
	3.8 – 4.0	Mayonnaise
	Various pH (from 2.0 to 4.0)	Fruits, pickles, sauerkraut, fruit butter
Low acidic	4.9 – 5.3	Carrot
	5.0 – 6.0	Bread
	5.0 – 6.0	Most cheese
	5.3 – 6.2	Fresh Beef
	5.3 – 6.4	Pork
	5.5 – 6.4	Chicken
	5.6 – 6.0	Potato
		Various pH (from 4.5 to 6.0)
Neutral (or almost neutral)	6.0 – 6.4	Egg yolk
	6.0 – 6.5	Mushroom
	6.5 – 6.8	Milk
	6.5 – 7.0	Fish
	7.0	Distilled water
Basic	6.8 – 8.2	Shrimp
	7.0 – 8.0	Eggs
	7.5 – 9.5	Egg white

The following list features a list of temperatures and food properties at the temperatures.

Source: The Oxford Companion to Food [Da00]

Temp (°F)	Significance	Things to make
32	Water freezes	Ice
73	Butter solidifies	
96	Butter melts	Butter for cooking
131 – 140	Egg white protein starts coagulation	
	Egg white coagulates	
150	Egg yolk protein starts coagulation	
158	Milk and egg yolk protein coagulates	Milk forms a film
212	Water boils	
223 – 236	Sugar thread	Garnishes
234 – 240	Sugar soft ball	Fondant, fudge
244 – 250	Sugar firm ball	Soft caramels, toffee
250 – 266	Sugar hard ball	Hard caramels, toffee, marshmallow, Edinburgh rock
270 – 290	Sugar soft crack	Butterscotch, humbugs, nougat, bullseyes, seaside rock
300 – 310	Sugar hard crack	Barley sugar, acid drops
320 – 350	Caramel	Nut brittle, praline
492	Soya oil (one of the most heatproof oils) smokes	

## APPENDIX C. SOFTWARE DOCUMENTATION

The following documentation is an excerpt of the documentation generated by javadoc from author's code.

### Package SpoonInterface

<b>Class Summary</b>	
<b><u>ImageCanvas</u></b>	<b>Helper class to display graphics in the application</b>
<b><u>SpoonFrame</u></b>	<b>Main class. Handles I/O connections, data interpretation and display.</b>

---

### Class ImageCanvas

java.lang.Object

|

+--java.awt.Component

|

+--java.awt.Canvas

|

+--**ImageCanvas**

#### All Implemented Interfaces:

javax.accessibility.Accessible, java.awt.image.ImageObserver,  
java.awt.MenuContainer, java.io.Serializable

---

public class **ImageCanvas**

extends java.awt.Canvas

#### See Also:

[Serialized Form](#)

---

### Field Summary

#### Fields inherited from class java.awt.Component

BOTTOM\_ALIGNMENT, CENTER\_ALIGNMENT, LEFT\_ALIGNMENT, RIGHT\_ALIGNMENT,  
TOP\_ALIGNMENT

#### Fields inherited from interface java.awt.image.ImageObserver

ABORT, ALLBITS, ERROR, FRAMEBITS, HEIGHT, PROPERTIES, SOMEBITS, WIDTH

## Constructor Summary

**ImageCanvas**(java.awt.image.ImageProducer imageProducer)

**ImageCanvas**(java.lang.String name)

## Method Summary

static void	<b>main</b> (java.lang.String[] argv)
void	<b>paint</b> (java.awt.Graphics g)

## Constructor Detail

### ImageCanvas

public **ImageCanvas**(java.lang.String name)

### ImageCanvas

public **ImageCanvas**(java.awt.image.ImageProducer imageProducer)

## Method Detail

### paint

public void **paint**(java.awt.Graphics g)

**Overrides:**

paint in class java.awt.Canvas

### main

public static void **main**(java.lang.String[] argv)

## Class SpoonFrame

java.lang.Object

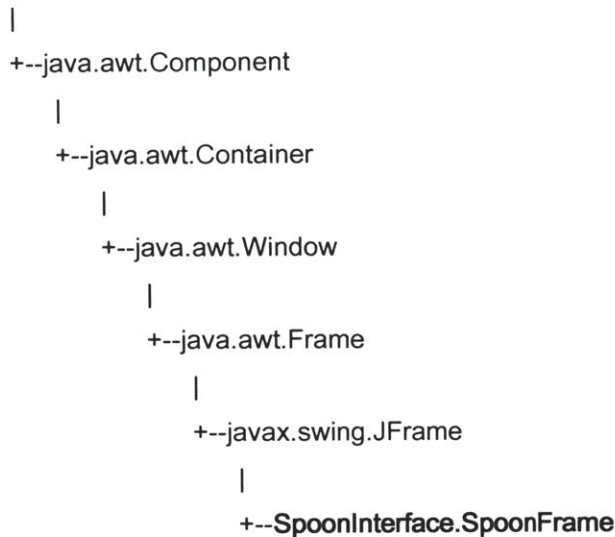

### All Implemented Interfaces:

javax.accessibility.Accessible, java.awt.image.ImageObserver,  
java.awt.MenuContainer, javax.swing.RootPaneContainer, java.io.Serializable,  
javax.swing.WindowConstants

---

```
public class SpoonFrame
    extends javax.swing.JFrame
```

### See Also:

[Serialized Form](#)

## Field Summary

### Fields inherited from class javax.swing.JFrame

accessibleContext, EXIT\_ON\_CLOSE, rootPane, rootPaneCheckingEnabled

### Fields inherited from class java.awt.Frame

CROSSHAIR\_CURSOR, DEFAULT\_CURSOR, E\_RESIZE\_CURSOR, HAND\_CURSOR,  
ICONIFIED, MAXIMIZED\_BOTH, MAXIMIZED\_HORIZ, MAXIMIZED\_VERT, MOVE\_CURSOR,  
N\_RESIZE\_CURSOR, NE\_RESIZE\_CURSOR, NORMAL, NW\_RESIZE\_CURSOR,  
S\_RESIZE\_CURSOR, SE\_RESIZE\_CURSOR, SW\_RESIZE\_CURSOR, TEXT\_CURSOR,  
W\_RESIZE\_CURSOR, WAIT\_CURSOR

### Fields inherited from class java.awt.Component

BOTTOM\_ALIGNMENT, CENTER\_ALIGNMENT, LEFT\_ALIGNMENT, RIGHT\_ALIGNMENT,  
TOP\_ALIGNMENT

<b>Fields inherited from interface javax.swing.WindowConstants</b>
DISPOSE_ON_CLOSE, DO_NOTHING_ON_CLOSE, HIDE_ON_CLOSE
<b>Fields inherited from interface java.awt.image.ImageObserver</b>
ABORT, ALLBITS, ERROR, FRAMEBITS, HEIGHT, PROPERTIES, SOMEBITS, WIDTH

<b>Method Summary</b>	
void	<b><u>appendToConnectionTextArea</u></b> (java.lang.String str) Append a new line of string to the text area in the ConnectionPanel
void	<b><u>closeConnection</u></b> () Close the connection and return to the ConnectionPanel
java.lang.String	<b><u>getConnectionPortText</u></b> () Get the text in the connection text field in the ConnectionPanel
static SpoonInterface.SpoonFrame	<b><u>getSpoonFrame</u></b> () Returns a handle to the singleton SpoonFrame object
Static void	<b><u>main</u></b> (java.lang.String[] args)
void	<b><u>makeConnection</u></b> () Establish a connection to the port with the name as indicated in the ConnectionPanel's port name textbox
void	<b><u>switchToDisplay</u></b> () Switch from selectionPanel to InfoDisplayPanel
void	<b><u>switchToMenu</u></b> ()

## Method Detail

### **getSpoonFrame**

public static SpoonInterface.SpoonFrame **getSpoonFrame()**  
Returns a handle to the singleton SpoonFrame object

---

### **appendToConnectionTextArea**

public void **appendToConnectionTextArea**(java.lang.String str)  
Append a new line of string to the text area in the ConnectionPanel  
**Parameters:**  
str - : String String to be appended

---

### **getConnectionPortText**

public java.lang.String **getConnectionPortText()**  
Get the text in the connection text field in the ConnectionPanel  
**Returns:**  
String content of the connection text field

---

### **makeConnection**

public void **makeConnection()**  
Establish a connection to the port with the name as indicated in the ConnectionPanel's port name textbox

---

### **closeConnection**

public void **closeConnection()**  
Close the connection and return to the ConnectionPanel

---

### **switchToDisplay**

public void **switchToDisplay()**  
Switch from selectionPanel to InfoDisplayPanel

---

### **switchToMenu**

public void **switchToMenu()**

---

## **main**

```
public static void main(java.lang.String[] args)
```

---



## APPENDIX D. CIRCUIT DIAGRAM

Circuit Diagram of the spatula with wireless transmitter

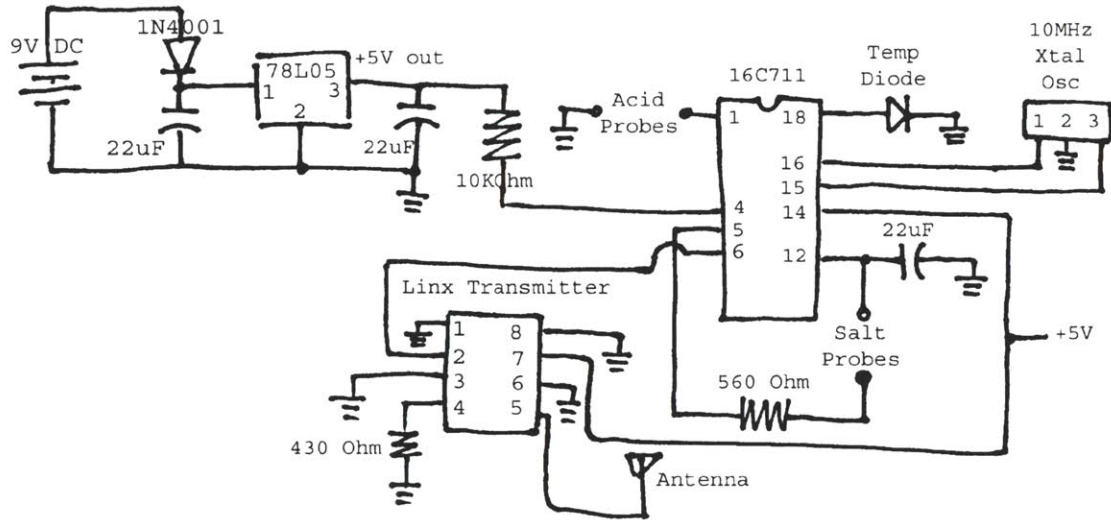

Circuit Diagram of the wireless receiver

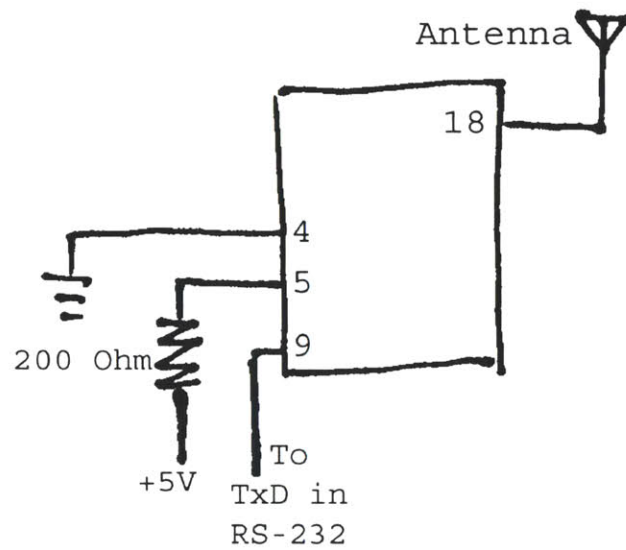



# APPENDIX E. APPLICATION SCREENSHOTS

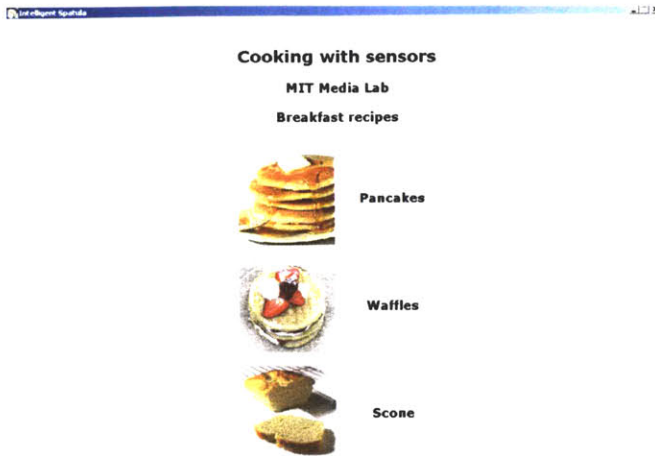

Screenshot from the main menu, where the user can choose different breakfast recipes. The application has recipes for pancakes, waffles, and scones.

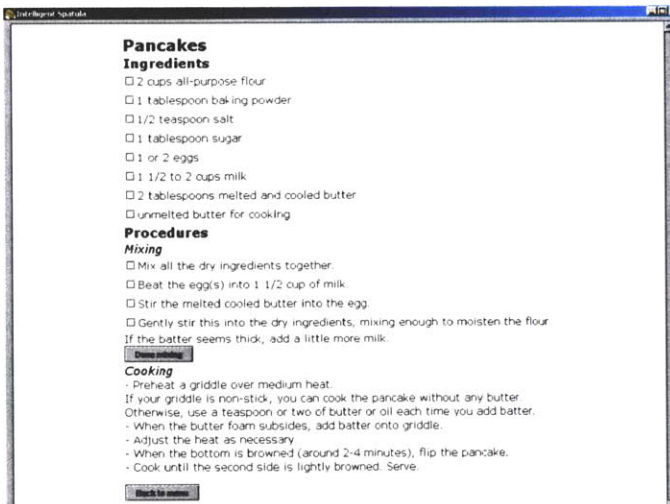

Screenshot from the initial recipe page. The user has not yet added any ingredients; all the checkboxes are unchecked.

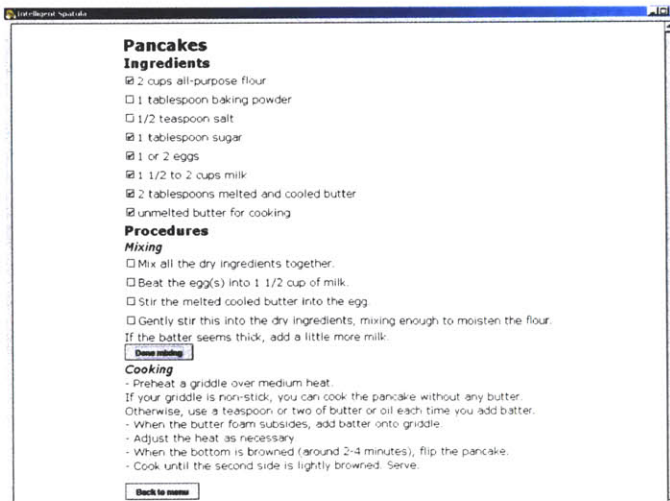

All ingredients have been added except baking powder (second box) and salt (third box). If click on the "Done mixing" button (first gray one) voice reminder would be played.

**Pancakes**

**Ingredients**

- 2 cups all-purpose flour
- 1 tablespoon baking powder
- 1/2 teaspoon salt
- 1 tablespoon sugar
- 1 or 2 eggs
- 1 1/2 to 2 cups milk
- 2 tablespoons melted and cooled butter
- unmelted butter for cooking

**Procedures**

**Mixing**

- Mix all the dry ingredients together.
- Beat the egg(s) into 1 1/2 cup of milk.
- Stir the melted cooled butter into the egg.
- Gently stir this into the dry ingredients, mixing enough to moisten the flour.

If the batter seems thick, add a little more milk.

**Cooking**

- Preheat a griddle over medium heat.
- If your griddle is non-stick, you can cook the pancake without any butter.
- Otherwise, use a teaspoon or two of butter or oil each time you add batter.
- When the butter foam subsides, add batter onto griddle
- Adjust the heat as necessary.
- When the bottom is browned (around 2-4 minutes), flip the pancake.
- Cook until the second side is lightly browned. Serve.

After baking powder is added, its box is checked off automatically

**Pancakes**

**Ingredients**

- 2 cups all-purpose flour
- 1 tablespoon baking powder
- 1/2 teaspoon salt
- 1 tablespoon sugar
- 1 or 2 eggs
- 1 1/2 to 2 cups milk
- 2 tablespoons melted and cooled butter
- unmelted butter for cooking

**Procedures**

**Mixing**

- Mix all the dry ingredients together.
- Beat the egg(s) into 1 1/2 cup of milk.
- Stir the melted cooled butter into the egg.
- Gently stir this into the dry ingredients, mixing enough to moisten the flour.

If the batter seems thick, add a little more milk.

**Cooking**

- Preheat a griddle over medium heat.
- If your griddle is non-stick, you can cook the pancake without any butter.
- Otherwise, use a teaspoon or two of butter or oil each time you add batter.
- When the butter foam subsides, add batter onto griddle.
- Adjust the heat as necessary.
- When the bottom is browned (around 2-4 minutes), flip the pancake.
- Cook until the second side is lightly browned. Serve.

The same is true for salt.

## APPENDIX F. **USER STUDY PROCEDURE**

The following is excerpted from our application for approval to Use Human as Experimental Subjects, submitted to MIT Committee On the Use of Humans as Experimental Subjects in January 2003.

### **Purpose of study**

This user study intends to evaluate an “intelligent spatula” being developed for my masters’ thesis. The spatula is embedded with sensors that measure the temperature, acidity, salinity, and stiffness of the food it is cooking, and can communicate with a personal computer that processes the information and makes suggestions to the chef. We will measure the performance and efficiency, as well as user experience, in the cooking process when using the intelligent spatula versus an ordinary spatula. The result of this user study will be used in improving the current spatula and making recommendations for designing smart kitchenware in the future.

### **Experimental Protocol**

For this experiment we will be recruiting 20-30 participants. Each person is expected to spend 1 to 1.5 hours in the kitchen of the Counter Intelligence group in MIT Media Lab. Subjects will be asked to follow two similar recipes, one with an ordinary spatula and the other with the intelligent spatula. Each recipe is supposed to take no longer than 30 (thirty) minutes to make.

Before beginning the task, a brief entrance session will take place to explain the experiment to the subject. During this session, the subject has the chance to ask questions and read and sign the consent form. Due to the potential hazards involved in cooking, safety will strongly be emphasized over completion of tasks or collection of data.

The subject will be asked to make two sauces according to two recipes. The combination of spoons and recipes and their sequences will be determined randomly. The cooking tasks will usually involve heating the sauces up to a certain temperature, and adding condiments such as vinegar and salt. Any preparation work that is not relevant to the spatula, such as washing and cutting raw materials, will be done for the subject before the experiment.

In both tasks, the user will be timed, and the properties (that is, temperature, acidity, and salinity) of the food will be monitored to determine the efficiency and performance of the subjects in the task.

Upon completion of both tasks, the subject will be asked to fill out a questionnaire about their experience with the spoon. Subject numbers will be assigned to preserve the anonymity of the data, and the questionnaire will not ask for name; only the investigators will have knowledge of the identity of the subjects.

The final goal of the experiment is to design an intelligent cookware that helps people in cooking, and to enhance the pedagogical value of a recipe by being interactive and gives appropriate suggestions at the right time. We would like to recruit people with different experience level, but there is no requirement for age, gender, or race.

## Sample Questionnaire

Subject Number: \_\_\_\_\_ Gender: \_\_\_\_\_ Age: \_\_\_\_\_ Date: \_\_\_\_\_

---

Please answer the questions below. You can decline to answer any of the questions. When you are done please submit the questionnaire to the experimenter.

### Background Information

1. How often do you cook (per week)?

Never    Less than once    1 to 2 times    3 to 5 times    More than 5

2. Please rate your feeling towards cooking:

- I love cooking.

False    1    2    3    4    5    6    7    True

- I cook for fun.

False    1    2    3    4    5    6    7    True

- Cooking makes me nervous.

False    1    2    3    4    5    6    7    True

- Cooking is boring.

False    1    2    3    4    5    6    7    True

3. How often do you use a recipe to cook?

Never    Seldom    Sometimes    Often

4. How many cookbook(s) do you own?

None    1-3    4-8    8-15    More than 15

5. What are your impressions for recipes from cookbooks and the Internet?

Boring    1    2    3    4    5    6    7    Interesting

Confusing    1    2    3    4    5    6    7    Clear

Too Board    1    2    3    4    5    6    7    Too Specific

Too little details    1    2    3    4    5    6    7    Too many details

Incomprehensible    1    2    3    4    5    6    7    Easy to understand

6. Have you ever attended a cooking class?

Yes    No

7. Do you want to improve your cooking skills?

Not at all    1   2   3   4   5   6   7    Very much

8. How hard is it to make a sauce?

Hard    1   2   3   4   5   6   7    Easy

9. What level would you say your computer skill is?

None    1   2   3   4   5   6   7    Savvy

10. How often do you use computer-aided cooking devices? (Examples are digital cooking thermometers, barbeque forks with temperature sensors, coffee makers that adjust water temperature based on coffee types)

Never        Seldom        Sometimes        Often

**Perception on cooking and computer-aided cooking**

The following section asks about your attitude towards cooking and computers in kitchen. Please rate the truthfulness of the following sentences.

11. Interactive cooking helps me cook better.

False    1   2   3   4   5   6   7    True

12. A computer is useful in helping me to cook.

False    1   2   3   4   5   6   7    True

13. A computer is useful in helping me to learn new recipes.

False    1   2   3   4   5   6   7    True

14. It is easy to work in a kitchen that is computer-mediated.

False    1   2   3   4   5   6   7    True

15. I am excited when cooking with the help of a computer.

False    1   2   3   4   5   6   7    True

16. With the help of a computer, I can cook faster.

False    1   2   3   4   5   6   7    True

17. With the help of a computer, I can cook better.

False 1 2 3 4 5 6 7 True

18. I believe that cooking with a computer interactively gives me more confidence.

False 1 2 3 4 5 6 7 True

19. I like cooking equipment that gives advice when I am cooking.

False 1 2 3 4 5 6 7 True

### **Interaction with the spoon**

This section asks about your cooking experience with the spoon.

20. Is the size of the spoon appropriate to hold in your hand?

Too small 1 2 3 4 5 6 7 Too big

21. Is the shape of the spoon comfortable?

Uncomfortable 1 2 3 4 5 6 7 Comfortable

22. Is the spoon convenient to use?

Inconvenient 1 2 3 4 5 6 7 Convenient

23. Will your excitement level changes when cooking with the spoon if you are more familiar with it?

Less excited 1 2 3 4 5 6 7 More excited

24. Do you think the spoon will be useful in an ordinary kitchen?

Useless 1 2 3 4 5 6 7 Useful

25. Do you think the spoon helps in your speed in cooking?

Cook slower 1 2 3 4 5 6 7 Cook faster

26. Do you think the spoon helps to improve your quality of food?

Worse food 1 2 3 4 5 6 7 Better food

27. Do you have any suggestions that help us make the spoon better?

28. Any comments that you have about the spoon and the experiment.

Thank you for your participation!



## BIBLIOGRAPHY

- [AS03] E. Arroyo, T. Selker, *Self-adaptive Multimodal-interruption interfaces*, Proceedings of IUI '03, 6-11, ©2003.
- [Be00] E. Bergman (ed), *Information Appliances and Beyond: interaction design for consumer products*, Morgan Kaufmann Publishers, ©2000.
- [BG75] J. Beard, M. Glaser, et al. (eds), *The Cooks' Catalogue*, Harper & Row, ©1975.
- [BrM] M. Brain, *How Food Preservation Works*, Howstuffworks, Inc., ©1998 - 2002. Available online at <http://www.howstuffworks.com/food-preservation5.htm> (Accessed December 2002)
- [Bi98] M. Bittman, *How to Cook Everything*, Macmillan, ©1998.
- [Ca80] S. Campbell, *The Cooks' Tools*, Morrow, Inc., ©1980.
- [CF97] J.R. Cooperstock, S.S. Fels, W. Buxton, K.C. Smith, *Reactive Environment: Throwing Away Your Keyboard and Mouse*, Communications of the ACM, 40(9): 65-73, ©1997.
- [Co97] S.O. Corriher, *Cookwise*, William Morrow and Co., ©1997.
- [CT95] J.R. Cooperstock, K. Tanikoshi, G. Beirne, T. Narine, W. Buxton, *Evolution of a Reactive Environment*, Proceedings of CHI '95, 170-177, ©1995.
- [Da99] A. Davidson, *The Oxford Companion to Food*, Oxford University Press, c.1999.
- [De01] M.L. Dertouzos, *The Unfinished Revolution: human-centered computers and what they can do for us*, HarperCollins, ©2001.
- [Di84] T.F. Dicker, *Computer Programs for the Kitchen*, Tab Books Inc., ©1984.
- [EB] "Toof", Encyclopedia Britannica. Available online at <http://www.search.eb.com/eb/article?eu=74801> (Accessed August 2003)
- [FDA00] US Food and Drug Administration, Center for Food Safety and Applied Nutrition, *Approximate pH of Foods and Food Products*, ©2000. Available online at <http://vm.cfsan.fda.gov/~comm/lacf-phs.html> (Accessed June 2003)
- [FM96] J.L. Flandrin, M. Montanari (eds), *Food: A culinary history from antiquity to the present*, Columbia University Press, ©1996.
- [Fo03] B.J. Fogg, *Persuasive Technology: using computers to change what we think and do*, Morgan Kaufmann Publishers, ©2003.
- [FT91] F. Bridge, J.F. Tibbetts, *The well-tooled kitchen*, William Morrow and Co., ©1991.
- [Go89] D. Goldbeck, *The Smart Kitchen*, Ceres Press, ©1989.
- [Hi99] K.S. Hilderbrand, Jr., *Preparation of Salt Brines for the Fishing Industry*, Oregon Sea Grant, Oregon State University, ©1999. Available online at <http://seagrant.orst.edu/sqpubs/onlinepubs/h99002.pdf> (Accessed November 2002)
- [Hi00] K.S. Hilderbrand, Jr., *Quick Determination of Water Phase Salt Content of Smoked Fish*, Oregon Sea Grant, Oregon State University, ©2000. Available online at <http://seagrant.orst.edu/sqpubs/onlinepubs/i00003.pdf> (Accessed December 2002)
- [JS03] J.A. Jacko, A. Sears (eds), *The Human-Computer Interaction Handbook: fundamentals, evolving technologies, and emerging applications*, Lawrence Erlbaum Associates, ©2003.
- [Ju01] W.G. Ju, *The Design of Active Workspaces*, Masters' Thesis, MIT, ©2001.
- [Ka01] J.N. Kaye, *Symbolic Olfactory Display*, Masters' Thesis, MIT, ©2001.
- [Ke10] E.E. Kellogg, *Science in the Kitchen*, Modern Medicine Publishing Co., ©1910.
- [Kr01] S. Krishnamoorthy, *Minerva: A Smart Video Assistant for the Kitchen*, Masters' Thesis, MIT, ©2001.
- [Li03] D.L. Lide, *CRC Handbook of Chemistry and Physics*, 84<sup>th</sup> Edition, CRC Press, ©2003
- [Ma00] K. Maney, *Computers sink as kitchen appliance – again*, USA Today, March 2000.
- [MW03] Merriam-Webster Dictionary, Dictionary entry for *Tool*, available online at <http://www.webster.com/cgi-bin/dictionary?book=Dictionary&va=tool> (Accessed August 2003), Merriam-Webster, Inc., ©2003.

- [Ni93] J. Nielsen, *Usability Engineering*, AP Professional, ©1993.
- [Ni03] J. Nielsen, *Ten Usability Heuristics*, ©2003. Available online at [http://www.useit.com/papers/heuristic/heuristic\\_list.html](http://www.useit.com/papers/heuristic/heuristic_list.html) (Accessed August 2003)
- [NI03] National Instruments, *Measuring Strain with Strain Gauges*, Application Note 078, National Instruments Corporation, ©April 2003.
- [No88] D.A. Norman, *The Design of Everyday Things*, Doubleday, ©1988.
- [No98] D.A. Norman, *The Invisible Computer: Why good products can fail, the personal computer is so complex, and information appliances are the solution*, MIT Press, ©1998.
- [OD02] E. Olsen, R. Dee, *Smart Sensing Spoon*, Class project for MIT EECS Independent Study.
- [PT84] A.M. Pearson, F.W. Tauber, *Processed Meats*, The AVI Publishing Company, Inc., ©1984.
- [RC00] J.E. Rushing, P.A. Curtis, *Acidified Foods: formulating dressings, sauces, and marinades*, North Carolina Cooperative Extension Service, ©2000.
- [SAW94] B. Schilit, N. Adams, R. Want, *Context-Aware Computing Applications*, IEEE Workshop on Mobile Computing Systems and Applications, 1994.
- [SI73] The Renwick Gallery of National Collection of Fine Arts, Smithsonian Institution, and the Museum of Contemporary Crafts of the American Crafts Council, *Objects For Preparing Food*, Smithsonian Institution, ©1973.
- [Sp00] D.Spicer, *If You Can't Stand the Coding, Stay Out of the Kitchen: Three Chapters in the History of Home Automation*, Dr. Dobb's Journal, ©2003.
- [US01] Food Safety and Inspection Service, US Department of Agriculture, *Cooking for Groups: A Volunteer's Guide to Food Safety*, ©March 2001. Available online at <http://www.fsis.usda.gov/OA/pubs/cfq/cfq7.htm> (Accessed December 2002)
- [WAF00] B. Wolf, E. Aronson, F. Fabricant (eds), *The New Cooks' Catalogue*, Alfred A. Knopf, ©2000.
- [Wi86] C. Williams, *The Williams Sonoma Cookbook and Guide to Kitchenware*, Random House, ©1986.
- [WT96] J. Wright, E. Treuille, *Le Cordon Bleu Complete Cooking Techniques*, William Morrow and Co., ©1996.

## **PHOTO CREDIT**

Page 16

Photos, Amazon.com, ©2002

Photos, Topac Inc., ©2000-2002

Page 18

Photos of individual items from Amazon.com, ©2002; editing by Connie Cheng, ©2003.

Page 24

Diagrams, National Instruments, ©2003.

Page 25

Circuit Diagrams, National Instruments, ©2003.

Page 27

Photo\* excerpted from <http://www.ddj.com/documents/s=1493/ddj0003hc/do200006hc001.htm>

Page 28

Advertisement, Honeywell Corporation, ©1969

Photo, Ed Thelen, ©2003

Page 30

Photo, AB Electrolux, ©1999

Photo, LG Electronics, ©2000

Page 32

Photo, Complements to the Chef, ©2001

Page 43

Graphics, Leonardo Bonanni, ©2003

Pages 41, 46, 47

Photos, Leonardo Bonanni, ©2003

\*Original artist and date of publication unknown

All other graphics and photos created by Connie Cheng, ©2003.