

A STUDY
OF
METHODS
OF
WASTE DISPOSAL
FOR
MILITARY CAMPS

By
Richard T. Whitney
1917

Course XI.

Richard T. Whitney
Richard T. Whitney.

ACKNOWLEDGMENTS.

The author wishes to express his appreciation and thanks to Professor George C. Whipple for his kindly interest and suggestions in the early part of this work; to Major Edwin S. Cole, U. S. A., for valuable information in regard to waste disposal methods used in our Army under various conditions and at different times; and to Adelbert Hiller, Assistant Editor of the American Public Health Reports, for the loan of two or three manuscripts upon this subject.

TABLE OF CONTENTS.

	<u>PAGE.</u>
CHAPTER I.	
Disease in the Army	6
CHAPTER II.	
Camp Wastes	23
CHAPTER III.	
The Disposal of Human Excrement by Burial	30
CHAPTER IV.	
The Disposal of Human Excrement by Incineration	47
CHAPTER V.	
The Disposal of Dry Rubbish, Garbage, Waste Waters, etc.	66
Bibliography	78

4

INDEX OF DIAGRAMS AND ILLUSTRATIONS.

	<u>PAGE.</u>
FIG. 1. Mortality from Cholera and Enteric among the British troops in India.	14
FIG. 2. Reduction of Enteric among British troops in India from 1903 to 1913.	15
FIG. 3. Results from Anti-Enteric Inoculation on Enteric in the U. S. Army.	17
FIG. 4. Plan of U. S. Regiment of Infantry.	34 ^a
FIG. 5. Plan of Fixed British Camp.	34 ^b
FIG. 6. Shallow "straddle" Trenches for Excreta.	36
FIG. 7. Cover for Deep Trench.	39
FIG. 8. Cross-Section of Company Sink.	40
FIG. 9. Dry Earth Closet.	44
FIG. 10. U. S. P. H. S. Closet.	45

FIG. 11.	Perspective View of McCall Incinerator.	54
FIG. 12.	Sectional View of McCall Incinerator.	55
FIG. 13.	McCall Incinerator, 1911 Model.	56
FIG. 14.	The Harris Incinerator.	58
FIG. 15.	The C. M. C. Incinerator.	60
FIG. 16.	The Conley Field Incinerator.	62
FIG. 17.	British Field Destructor.	64
FIG. 18.	Rock Pile Crematory.	69
FIG. 19.	Barrel and Trench Crematory.	71
FIG. 20.	Barrel Crematory.	72
FIG. 21.	Pit Crematory.	74
FIG. 22.	Slop Water Filtration Trench.	76

CHAPTER I.

DISEASE IN THE ARMY.

CHAPTER I.

Every form of camp sanitation, whether it be the disposal of waste, the purification of the water supply, or anything else, has but one primary object in view, viz.- the prevention of disease. It must be recognized first that there are no diseases which are peculiar to soldiers. There are, however, certain diseases to which, because of their work and environment, soldiers are particularly liable. "The men who compose an army are drawn from civil life, in which each individual has, to a greater or less extent, independent control of his time, choice of occupation, selection of food and dwelling place, and general sanitary care. After enlistment, soldiers lose most of this independence; they are housed, clothed, fed and exercised under regulations which it is beyond their power to amend; they are moved from one point to another, differing very widely perhaps in climatic and other conditions, under orders which they may not presume to question; their hours for sleep, meals, work and recreation are fixed for them without consultation with them or without regard to individual or communal preference." (Harrington).

The diseases which are, and have been, the most prevalent among the armies of the world, may be divided into two general classes;

(1) The large and all important group of infectious diseases; and

(2) Those conveyed by vermin, parasites, exposure to weather extremes, immoral habits, and improper diet.

In this thesis, it is not the idea of the author to attempt a complete discussion of all the diseases of these two classes and only those of extreme importance will be considered.

TYPHOID FEVER.

Greatest of all the diseases which the soldier is subject to is, of course, typhoid fever. Kean, in 1905, said, "Typhoid fever is to-day, on account of its wide dissemination, the persistent vitality of the infecting organism, the duration and severity of its attack, and its large death rate, the most formidable infectious disease with which we have to contend in military life." Examples of the ravages which typhoid has caused in military life in the past are so numerous that

volumes could be written on this single subject. A few of the more notable examples may well be considered here. Quoting from Keefer's book, "Military Hygiene":-

"Typhoid fever (or enteric as the English call it) has for many years been known as the 'Scourge of Armies.' In our Civil War the Union Army had over 80,000 cases recognized as such, and there were probably as many more which, because of imperfect means of diagnosis, were thought to be malaria or other affections.

War of 1870:- The Germans, in the war with France in 1870, had over 73,000 cases and nearly 7,000 deaths, although active hostilities lasted but six months.

The Boer War:- The British Army, in South Africa, while fighting with the Boers, had 57,000 cases and 8,000 deaths.

War of 1898:- In our War with Spain we had 20,738 cases with 1,580 deaths, among 108,000 men, all occurring within three and a half months; one man in every six had the disease, while this proportion was increased to 1 in 5 among those regiments which never left the United States. Typhoid fever caused nine-tenths of all deaths occurring among troops encamped in the United States in 1898.

Such instances might be multiplied indefinitely, but enough has been said to show what an immense amount of sickness and military inefficiency - to say nothing of the suffering and death of individuals, with economic loss - this dread disease causes."

Typhoid is caused by a vegetable germ known as typhoid bacillus. It multiplies with enormous rapidity and finds the most favorable soil for increase and growth in the bowels of human beings. It can readily be seen, therefore, that the disease is spread by the transfer of the germ in some manner from the excretions of the infected person to the intestinal tract of another. This may be done in several ways, by direct contact, infected water, milk or food, by dust, flies, soiled hands, etc. It is easy to see that the spread of typhoid may take place more easily in military camps, where men are of necessity crowded together and where the difficulty for immediate and complete disposal of wastes is difficult or even impossible, than in the more ordinary walks of life.

In every hundred cases of men who have recovered from typhoid attacks there are three or four who continue to breed the germs in their bodies.

These men are called "carriers." Now, let us suppose that one such man is in a company. His hands are likely to be soiled, so that everything he touches becomes contaminated and, when someone else touches the same thing, the chances are good for his catching the disease. Again, unless this "carrier" is particularly careful to cover his excreta, if a trench system is in use, the flies get in and later carry the deadly germ into tents, or even the camp kitchens, contaminating the food later to be eaten by the men. Thus it is easy to see how comparatively easy it is for this disease to get a start in camp, and once started the risks grow, with the number of men infected, in geometric progression. In the Spanish-American War it can be noted that the three chief factors responsible for the thousands of cases were uncovered excreta, flies and personal contact.

It has been found that a person who has had typhoid and recovered from it, becomes immune to the disease. Substances are found in the blood antidotal to the typhoid bacillus and so a few years ago an English investigator began work to find something which would artificially produce these substances in the body. The result has been the anti-

typhoid injections. These consist of the injection, by means of a hypodermic syringe, of a certain quantity of the antitoxin, usually in the arm. The early results following inoculation are the reactions which occur. Incapacitation occurs as follows:-

Incapacitated for	5 days,	1 per thousand.
Incapacitated for	3 days,	3 per thousand.
Incapacitated for less than 3 days,		996 per thousand.

If care is taken the danger of the reaction necessitating the admission of a man to the hospital becomes a minimum. In one case there were 27,000 inoculations without a single hospital admission. In 99 per cent. of cases the man inoculated is capable of carrying out his routine duties at the end of forty-eight hours, while less than 5 per cent. show even moderately severe reactions. In most cases, if the dose is administered in the afternoon, the symptoms are entirely gone by the next morning.

Inoculation has done more to prevent typhoid in armies than anything else. Statistics, which are so numerous that only a few of the more striking or interesting can be discussed, show clearly the beneficial results obtained from this source.

(1) A British cavalry regiment at Meerut, India, had 200 inoculated and 300 uninoculated men. Sixty cases of typhoid occurred in an outbreak among these men, all living under the same conditions. The cases were distributed among the groups as follows:-

<u>Fully Protected.</u>	<u>Partially Protected.</u>	<u>Wholly Unprotected.</u>
Nons.	2	58

(2) From a series of tests made by twenty-four special medical officers distributed among the English troops, the following facts were obtained:- (quoted verbatim from "Sanitation in War").

"If two men of similar physique and age - one inoculated and the other uninoculated - are exposed to similar risks of enteric and one is going to get it, the odds are $5 \frac{1}{2}$ to 1 that it will be the uninoculated man; while, if one of them is bound to die of it, the odds lengthen to $10 \frac{1}{2}$ to 1 that it will be the unprotected man."

(3) Data of the whole British Army in India during ten years (Figures 1 and 2). Inoculation was reintroduced in 1905 and by 1913, 90% of the men were inoculated. The figures are what might be expected:-

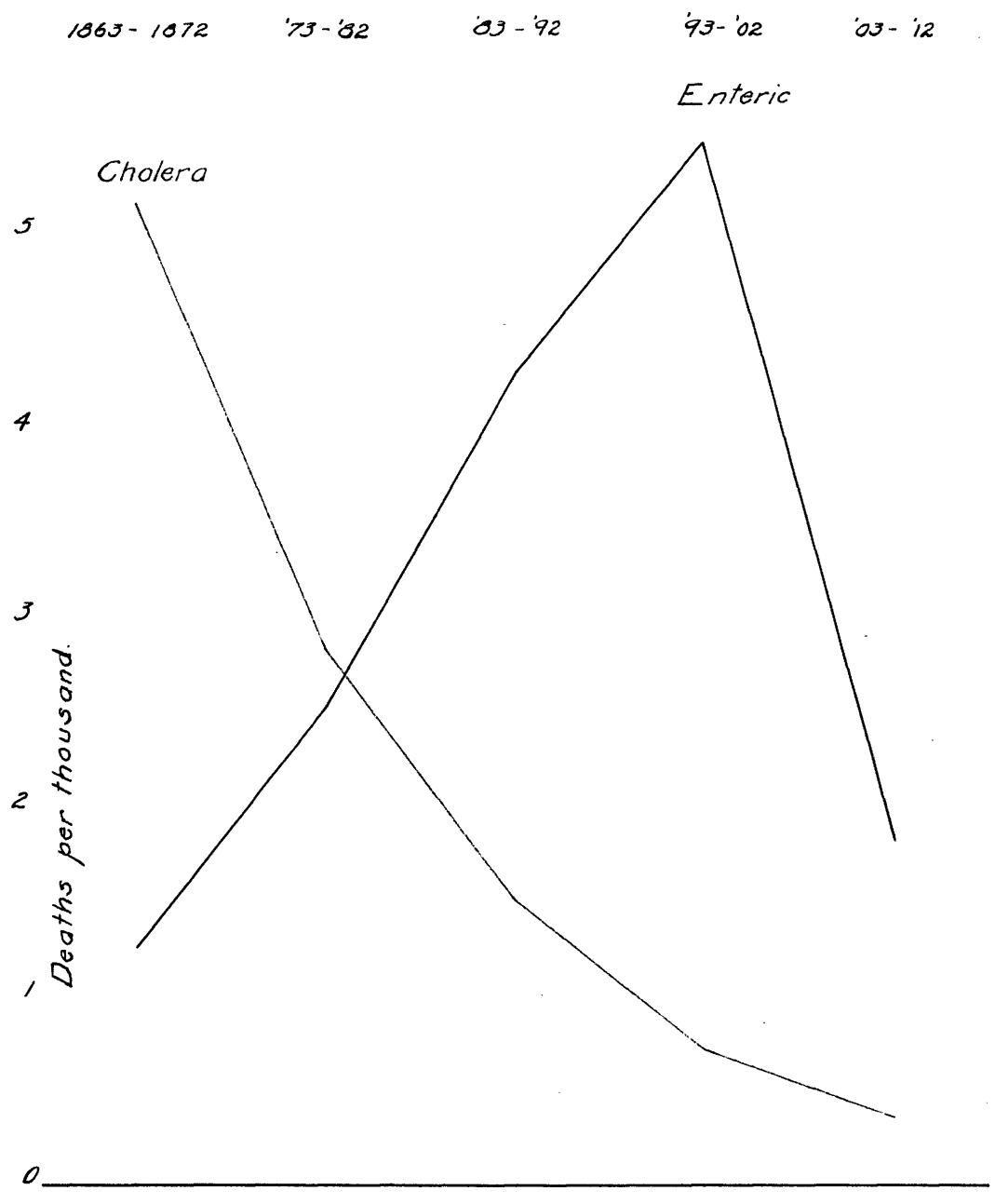

Mortality from Cholera and Enteric among the British troops in India.

from "Sanitation in War."

FIGURE 1.

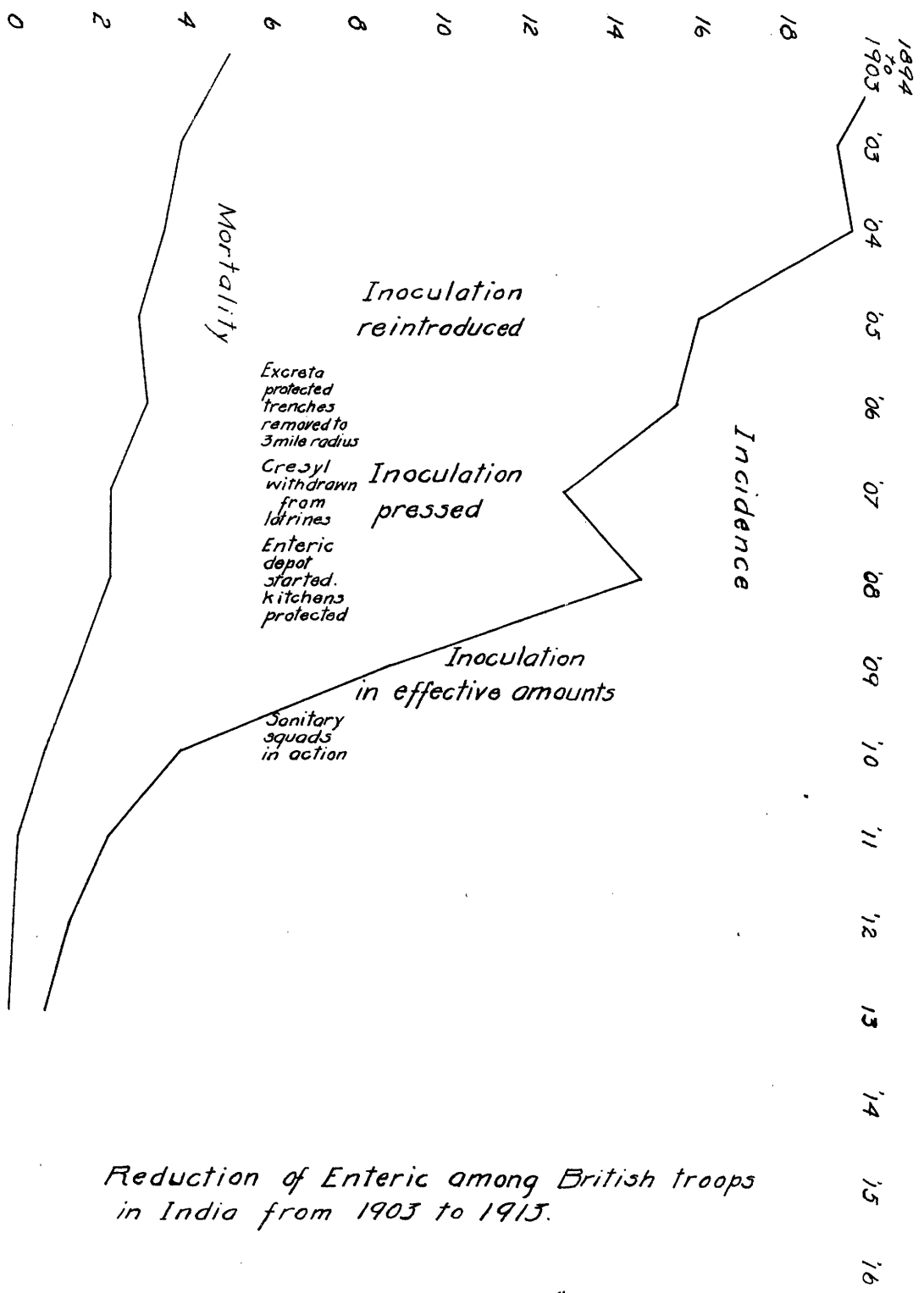

Reduction of Enteric among British troops in India from 1903 to 1913.

from "Sanitation in War."

FIGURE 2.

	<u>Admissions.</u>	<u>Deaths.</u>
1905	1,146	213
1913	85	16

In deaths and medical expenses alone this probably represents a saving of about \$250,000.00 a year.

(4) The most striking figures of all are those of our own army in which anti-typhoid inoculation has been made compulsory (Figure 3). This has almost completely prevented typhoid fever in the army, there being no deaths from this cause since 1908, and in the year 1913, in an army of 90,000 strong, only three cases of typhoid fever occurred.

(5) A comparison between an army division in Florida in the Spanish War of 1898 and a division in Texas during the Border troubles of 1911, shows clearly what the effect of inoculation has been. These two divisions lived under practically the same conditions as regards climate, season, water supply, etc., and were approximately of the same strength. The Texas division had, it is true, better waste disposal methods, but its complete immunization by means of the anti-typhoid prophylactic constituted the following difference:-

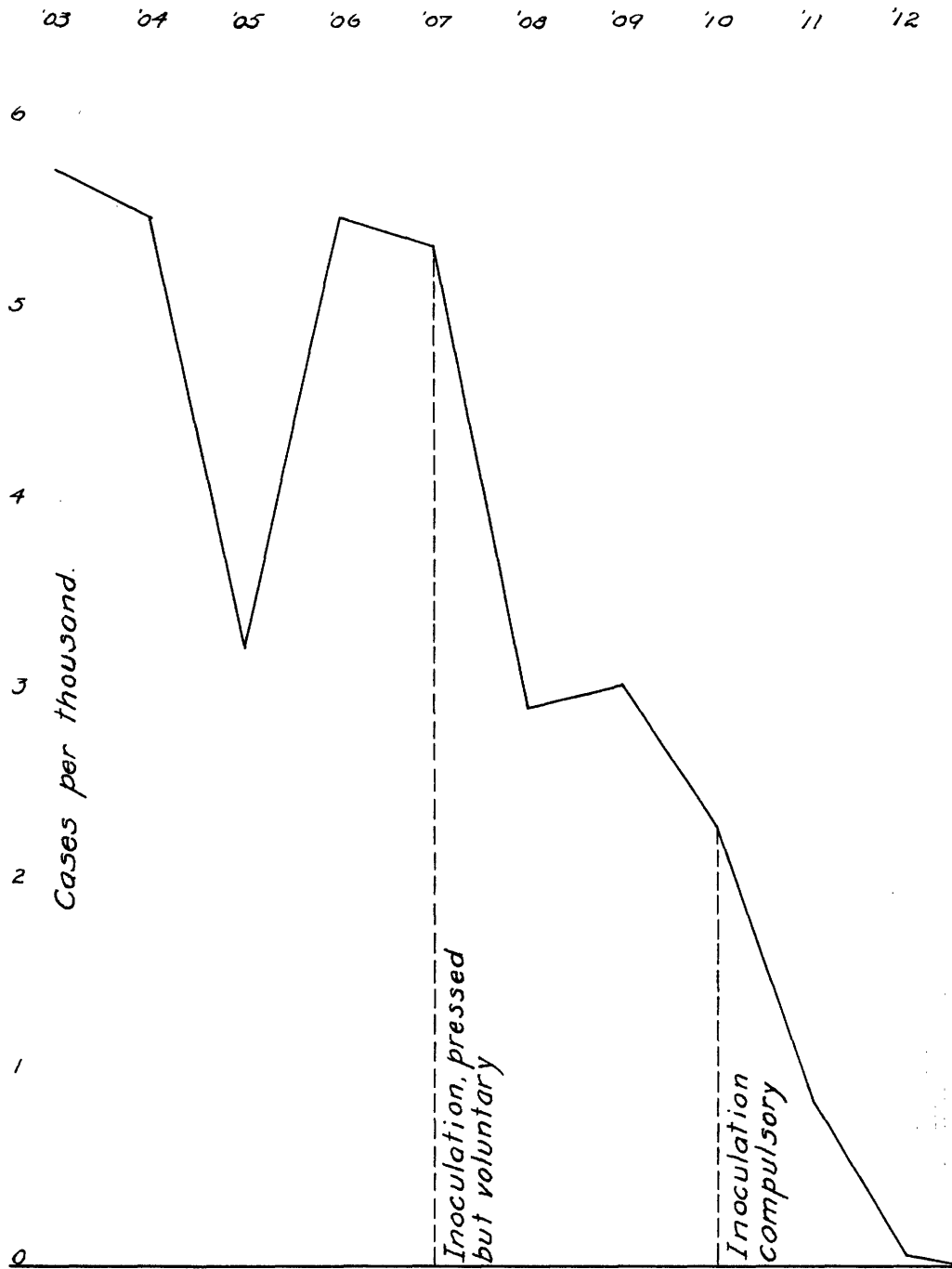

Results from anti-enteric inoculation on enteric in the U.S. Army.

from "Sanitation in War."

FIGURE 3.

<u>Year.</u>	<u>Mean Strength.</u>	<u>Cases of Typhoid.</u>	<u>Deaths from Typhoid.</u>
1898	10,759	2,693	248
1911	12,801	2	0

DYSENTERY AND DIARRHEA.

Dysentery is, "broadly speaking, any inflammatory disease of the bowels in which blood and mucus appear in the stools." There are two forms of dysentery, depending upon the parasite which causes it. The kind caused by animal parasites is called Amebic, and that caused by vegetable parasites, Bacillary Dysentery. The latter is the more dangerous, and is sometimes almost as rapidly fatal as cholera. Since this disease is caused by intestinal organisms, its spread may take place in precisely the same way as typhoid and the same precautions that are used against typhoid must be employed, viz.- disposal of excreta, the sick should be separated from the well, the water supply should be protected, etc. Unfortunately, as yet, no vaccination has been found for this disease.

Diarrhea is very common among the soldiers, and may result from a variety of causes, such as

poor food, canned goods, careless cooking, etc.

There is also an epidemic diarrhea which is probably due to the presence of the dysentery bacillus in the intestines.

TYPHUS.

This dread disease is caused principally by famine, filth and vermin. The chief carrier of the disease is the body louse. The most striking example of typhus has been in the present European War, when the whole of Servia was practically overrun by this disease. It has also been commonly found in the trenches of all the fighting forces and constitutes one of the most dread of the so-called war diseases.

MALARIA AND YELLOW FEVER.

Malaria and Yellow Fever are probably of little importance to-day. They are both caused by the bite of an infected mosquito; the so-called anopheles, causing malaria and the stegomyia yellow fever.

CEREBRO-SPINAL MENINGITIS.

This disease is caused by a micrococcus, which, when breathed, lodges in the throat. Fortunately but few are susceptible to this disease, for its death rate is very high (70 % in untreated cases). An antimeningitic serum is used to treat the disease and should be used very promptly. It has caused considerable anxiety among the troops at the front in the present war. It has been found that 40 % of contacts become "carriers," due to a naso-pharyngeal infection which lasts from twenty to thirty days.

PLAGUE.

Plague is another vermin disease which established itself regardless of climate wherever it finds favorable conditions. It is caused by the bite of the rat flea, which leaves the rat after its death and attacks man. Rats are very common in the trenches and strenuous efforts are being made to exterminate them, because of their association with this disease.

SCURVY.

This disease results from scarcity or improper diet caused chiefly by the absence from the diet of the organic acids of meats and vegetables. It is tested for by a blood test, which shows the normal alkalinity of the blood to be reduced to the equivalent of three times diluted $N/10$ acid. Scurvy attacked the beleaguered garrison of Russians at Port Arthur, where 83 % of the whole garrison contracted this disease. Lemon and lime juice are both preventive and curative.

TUBERCULOSIS.

Commonly known as "consumption," tuberculosis is primarily a lung disease and is spread by men breathing the air infected with the tubercle bacillus. It may also be conveyed by milk and sometimes by food. Men closely cramped together, as in prison camps, guard houses, etc., are especially liable to contract this disease and its spread is rapid and virulent. It is said that this disease is causing great suffering and many deaths among the unfortunate prisoners of war held by Germany. Fresh air is the greatest preventative for this disease/

OTHER DISEASES.

There are many other diseases to which the soldier is particularly liable, among which the following can be grouped together under the head of Exposure Diseases:-

Tonsillitis, Influenza, Colds, Effects of Heat and Cold Exposure, Blistered Feet, etc.

Some of the other contagious diseases, of minor importance, which have, however, in times past caused great epidemics, are:-

Diphtheria, Smallpox, Cholera, Scarlatina, Mumps, Measles, Hookworm Disease, Dengue, Beriberi, Leprosy, etc.

CHAPTER II.

CAMP WASTES.

CHAPTER II.

After the camp site has been selected with due care to proper sanitation, immediately arises the question of waste disposal. Colonel Frank R. Keefer, in his splendid book upon "Military Hygiene and Sanitation," says:

"The most essential feature of camp sanitation is the efficient disposal of wastes."

Major P. S. Lelean, R. A. M. C., has recently put into book form a series of lectures upon camp sanitation, which he calls "Sanitation in War." In this he defines conservancy, the English term for waste disposal, as follows:-

"Conservancy is that branch of sanitation which deals with the disposal of waste products. This sanitary necessity stands in relation to one of the most definitely established laws of hygiene which has yet been enunciated - that all life is choked by the accumulation of its own products."

Wastes may be defined as those substances for which man has no further need. These substances may become in time, if not properly disposed of, a source of danger, and a cause of sickness, disease, and even death. Such wastes may be either solid or liquid. In military camps, where men are crowded

together in large numbers, the problem of efficient disposal of wastes may assume large proportions. The indiscriminate disposal of waste matters in military camps which are constantly moving, as during a campaign, may not be of so much consequence, but in a semi-permanent camp, it is, as Major Munson says, a matter of life or death.

Camp wastes may be conveniently put in six groups, as follows:-

1. Human excrement (feces and urine).
2. Garbage (solid kitchen refuse, food, etc.).
3. Waste water (kitchen sinks, baths, basins, etc.).
4. Animal manure (horses, cattle, etc.).
5. Dry Rubbish (waste paper, boxes, bags, etc.).
6. Storm waters.

The above classification is in the order of importance with relation to health. The disposal of human excrement is by far the most important of all. It is interesting to note what two of the more important writers upon military sanitation say in this regard.

"The disposal of human excreta is one of the most important problems that confront the mili-

tary hygienist, one that should be the object of the constant solicitude of the medical officer and require his most careful attention." (Havard's Military Hygiene).

And again, "If we had a perfect method of disposal of these waste products of the body, it would not be long before typhoid fever would cease to appear in epidemic form, and only an occasional case would be encountered as the result of direct contact with an infected individual. But, under the imperfect sanitary conditions of modern existence, it will be a long time before this is realized, and in the meanwhile we must employ such measures as will reduce to a minimum the risks of contact with infectious material." (Keefer's Military Hygiene).

This special phase of the waste disposal in camps is of course the most important. Human excrement is the chief source of danger in regard to all diseases of intestinal nature and carelessness in its immediate and thorough disposal has been the prime cause for fully two-thirds of the sickness in the armies of the world.

The disposal of excreta in military camps depends of course largely upon the size, location

and degree of permanency of the camps. In the forts, and camps of a permanent nature, sewerage systems are generally installed and the water carriage system used. This system is of course the ideal one and should be used whenever possible. But in the camps of a less permanent nature, where a large number of men are brought together for a short length of time, or in time of war, when the encampment is subject to change of position, the water carriage system is impossible. It is the disposal of wastes in this latter type of camp, which the author has attempted to discuss in this thesis.

Human excrement in camps of semi-permanent nature may be disposed of chiefly in one of two ways, viz.- either it can be burned (incinerated), or buried. Both of these systems will be discussed later in this thesis. In the present European War, trench warfare has been used from the beginning. Here the disposal of the waste materials is practically that of a siege. For a time excreta was disposed of by placing it in tins and lobbing them into the enemy trenches, which happened to be near enough. Reprisals occurred and were found so unpleasant that this method has been abandoned by both sides. The burial system and the pail system have been more re-

cently adopted, but the almost constant shelling and rifle fire have made the proper disposal of wastes in the trenches an arduous and disagreeable proposition. So little is known of the actual conditions which exist in the trenches that the author feels justified in leaving this phase of the subject out of consideration.

The almost universal method of disposing of garbage and dry rubbish, of which there is an abundant quantity, in a military camp, is by burning. There are many various ways in which this can be done and the more important of these are discussed in a later chapter.

The disposal of the other kinds of camp wastes, waste water, animal manure, etc., is of minor importance and is carried out largely to preserve an orderly and cleanly appearance of the camp. It is a well-known psychological fact that, with disorderliness and filthy conditions, men lose their sense of decency and conditions grow rapidly worse and disease prevails. When we consider that almost all of the disease in the army has been unnecessary, that the loss of life from disease in every war until the Russo-Japanese conflict, has been nearly four times as great as that caused by the actual

fighting and that two-thirds of this disease and loss of life could be prevented by an efficient system of waste disposal, it seems almost self-evident that time, money and effort should be spent to attain this end.

In the British Army, in the wars of the thirty years previous to the present European conflict, for every one man killed by the enemy, there were forty hospital admissions and the loss of 4.8 lives. If then by spending more time and money in developing waste disposal systems for our military camps, we can reduce this sickness and loss of life, would it not be a great economic saving, a means for a more efficient army, as well as a great saving in human life?

CHAPTER III.

THE DISPOSAL OF HUMAN EXCREMENT BY BURIAL.

CHAPTER III.

As has been said before, the chief source of danger of typhoid fever and other intestinal diseases in military camps is human excreta. Its prompt and efficient disposal, then, is primarily the thing we wish to attain. Two general methods present themselves, namely: the burial system and that of incineration. The burial system is, perhaps the oldest system of disposal known. In the English bible (revised) we find Moses instructing his people, when they were encamped in Africa and suffering from a "Plague of flies," as follows:

"Thou shalt have a place also without the camp whither thou shalt go forth abroad: And thou shalt have a paddle (shovel) among thy weapons; and it shall be, when thou wilt ease thyself abroad, thou shalt dig therewith, and shalt turn back and cover that which cometh from thee." Deuteronomy XXIII. 12-13. The burial system is still the official system in our army to-day and in many cases is still the most desirable.

The subject of excreta disposal in camp is treated in the United States Army Infantry Drill Regulations, published in 1911, as follows:-

"DISPOSAL OF EXCRETA.

674. Immediately on arriving in camp sinks should be dug. This is a matter of fundamental sanitary importance, since the most serious epidemics of camp diseases are spread from human excreta.

One sink is usually provided for each company and one for the officers of each battalion. Those for the men are invariably located on the side of camp opposite the kitchens. All sinks should be so placed that they cannot pollute the water supply or camp site as a result of drainage or overflow. To insure this, their location and their distance from camp may be varied.

When camp is made for a single night, shallow trenches, 12 inches deep and 15 to 18 inches wide, which the men may straddle, will suffice.

In more permanent camps, the trenches should be about 2 feet wide, 6 feet deep, and 15 feet long. They should be provided with seats and back rests made of poles, and should be screened by brush or old tent flies.

675. In cold weather the contents of sinks should be covered once daily with quicklime, ashes, or dry earth. When filled to within 2 feet of the

top, sinks should be discontinued and filled in.

Open pits are dangerous during the fly season. However, the danger may be greatly reduced by covering the excreta with earth or by a thorough daily burning of the entire area of the trench. Combustible sweepings or straw, saturated with oil, may be used for this purpose.

In fly season, trenches may be closed with seats covered down to the ground with muslin and supplied with self-closing lids. Urinal troughs, made of muslin and coated with oil or paint, should discharge into the trenches.

676. In permanent camps, special sanitary facilities for the disposal of excreta will ordinarily be provided.

If necessary, urinal tubs may be placed in the company streets at night and removed at reveille. Their location should be plainly marked and thoroughly and frequently disinfected.

677. When troops bivouac for the night the necessity for extensive sanitary precautions is not great; however, shallow sink trenches should be dug to prevent general pollution of the vicinity. If the cooking be collective, shallow kitchen sinks should be dug. If the cooking be individual, the

men should be required to build their fires on the leeward flank of the camp or bivouac.

Before marching, all trenches should be filled in."

The site of the camp latrines with respect to the rest of the camp is of great importance. They should be so situated that there will be no danger of polluting the water supply and should be on the opposite side from, and to leeward of, the kitchens. Figure 4 illustrates diagrammatically the usual layout of the camp for a regiment of infantry, the latrines being marked in red. Figure 5 shows the standard plan of fixed British camp showing living, transport and sanitary areas. The latrines should be well screened for privacy by brush or old canvas strung over poles. They should be lantern-lighted at night and should have an orderly in charge of them to see that they are kept in a cleanly state. It should also be the duty of this orderly to report at once to the medical officer any undue amount of diarrhea or bowel disturbances among the men. He should also report the failure of any man to cover his droppings with a sufficient quantity of earth and the man should receive a sharp penalty, for it is individual carelessness which endangers the health of the entire unit. Urinal cans, or tubs, should be placed

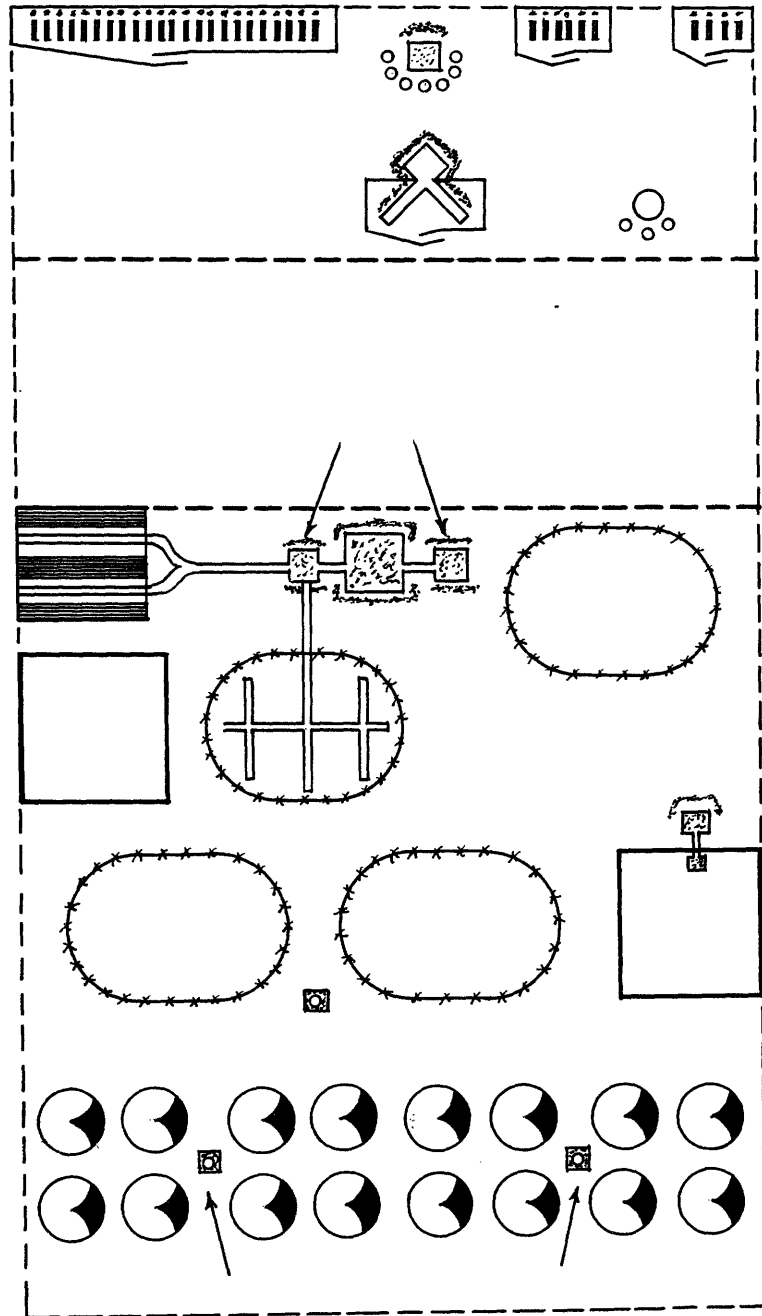
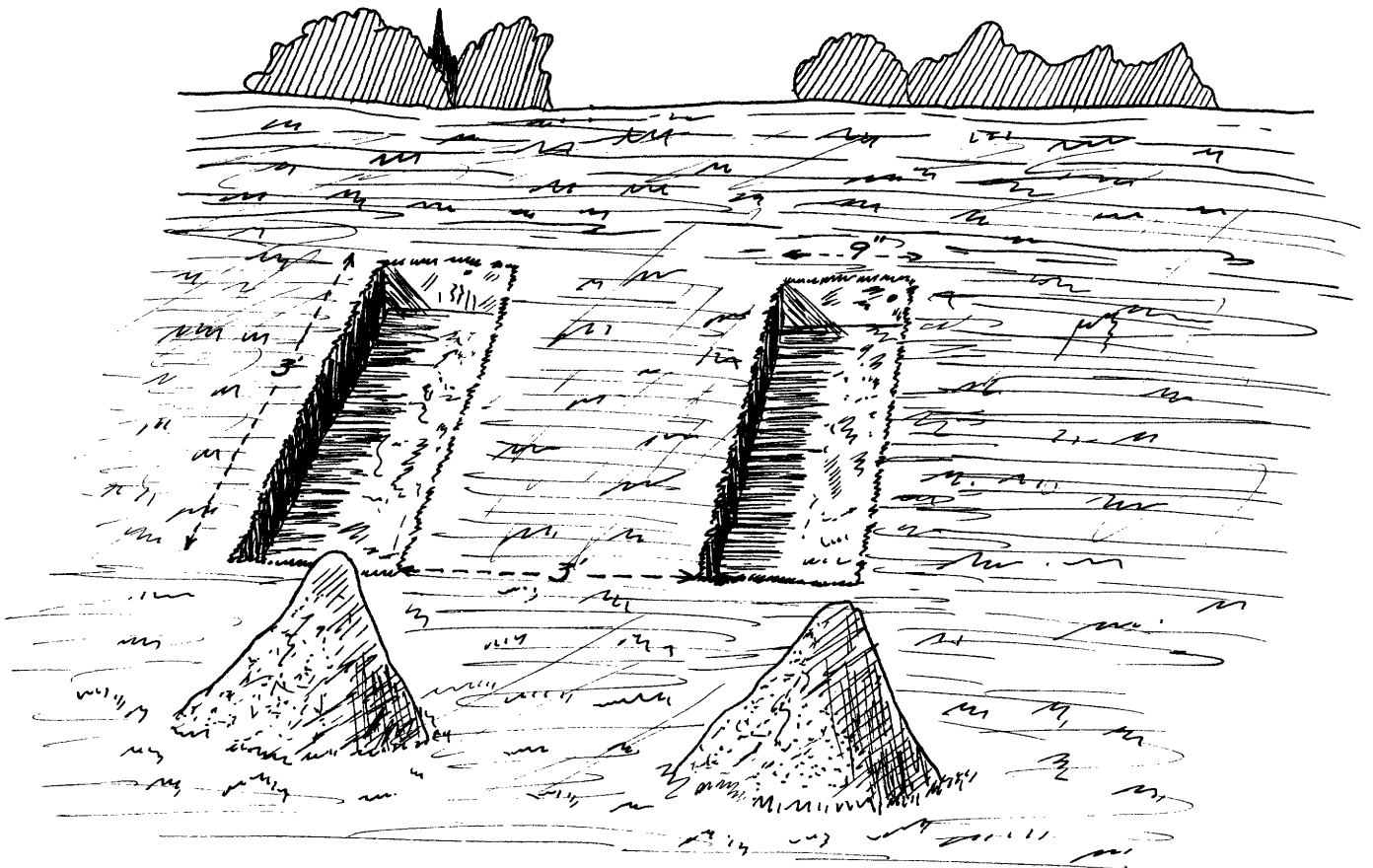

FIGURE 5.

in the company streets at night and marked by lanterns. Toilet paper is provided in rolls by the quartermaster and the latrine orderly should see that this paper is not allowed to blow out of the latrines and thus about the camp.

In the direct burial system, the feces are dropped directly into a trench, previously dug in the ground. This trench may be of various size or shape, according to the use which is to be expected of it, the length of time it is to be used, etc. There are, in general, two types of excreta trenches; the shallow and the deep. There are standard sizes for each of these trenches given in the Army Regulations, and each of these will be treated separately. Regardless of the size or shape of the trench, it should be filled in and mounded over before the camp is left. It is thus indicated to any subsequent occupants of the camp.

The shallow straddle trench is illustrated in Figure 6. This sort of trench should be dug and used, the Army Regulations say, in camps of a single night. At least two experienced authors on this subject suggest that the shallow trench be used altogether and that the use of the deeper sinks be given up. Their arguments in favor of such an ar-



Shallow "straddle" trenches for excreta.

FIGURE 6.

rangement are good. They point to the fact that in the case of the old, long, deep trench, one side is heavily fouled by feces right up to the ground level, while the ground in front is generally saturated with urine. Infective material is therefore apt to be brought back to camp on the men's feet. It is also extremely difficult, and sometimes impossible, to cover the feces entirely, flies being thereby enabled to gain access to it. Both of these objections are obviated by the shallow, narrow trench, which allows the user to stand with one foot on either side and thus deposit his excreta directly into the middle of the trench. A shallow trench, such as the standard trench used in the British Army, is three feet long, by one foot wide, by one foot deep, accommodates one person at a time and provides for 33 per cent. of the strength of a unit for one day's stay or 20 per cent. for a longer halt.

The deep trench, known to our army as the "Company sink," possesses certain advantages which the shallow trench does not. Where a camp is to be made for any considerable space of time, a company sink is generally the form of latrine used. These company sinks are ordinarily fifteen feet long, two feet wide, and six feet deep, but in case of large organizations, they have to be made longer. The

trench should be covered with box seats, of which a simple illustration is given in Figure 7. These box seats can be very simply constructed and attention should be paid to some of the minor details in their construction. For instance, the back should slope away quite sharply in order to prevent its being soiled by excreta; the holes should be oval and not round; the covers should be arranged so that they will close themselves; a piece of tin, or galvanized iron, should be nailed on the front of the box to direct the urine into the pit; the seats should be hinged with galvanized hinges, but, if this is found impractical, leather strips can be used for this purpose. The box seat is then placed over the pit. If the edges of the pit are apt to crumble away, boards should be laid along the sides and the box placed on them.

When it is not possible to construct a box, or board, seat, a pole seat (Figure 8) may be constructed as follows:-

Crossed timbers, or stakes, are driven at intervals so that their intersection will come over the center of the trench. A long, smooth pole is nailed into these intersections of the stakes and sometimes a second pole is nailed below for a foot rest.

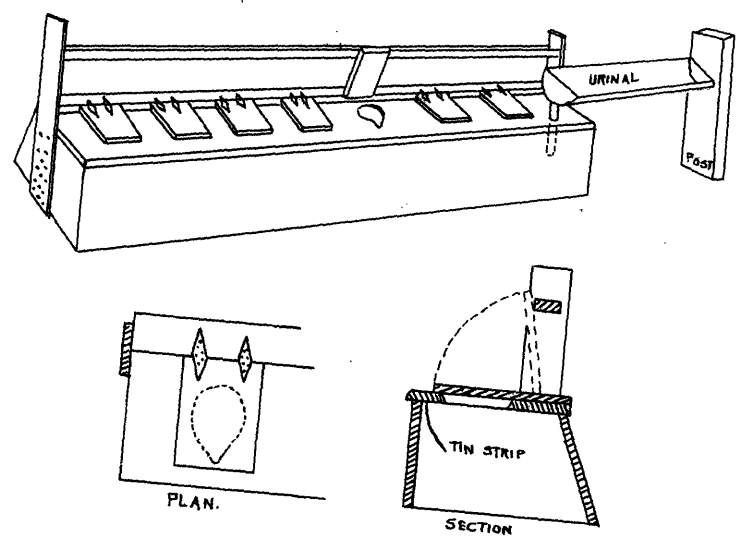

COVER FOR DEEP TRENCH.
FIGURE 7.

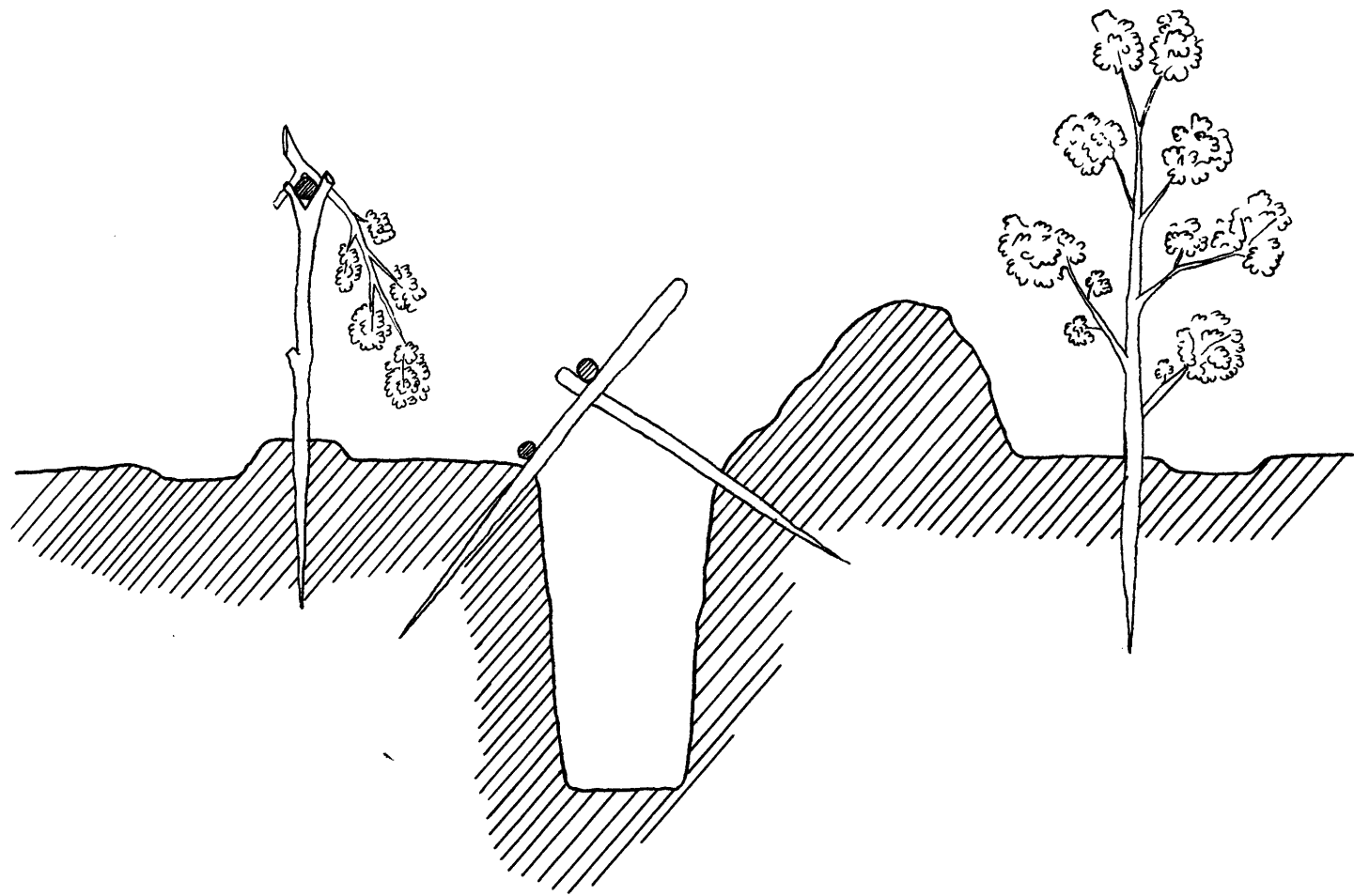

*Cross-section of Company sink.
showing pole seat, screening, and ditching.*

FIGURE 8.

The pit should be burned out every day by removing the seat, or seat cover, and sprinkling hay and oil over the contents. To burn the pit out from five to six pounds of hay and two to three gallons of oil will be required. The oil should be well distributed over the sides of the pit. In burning out the pits care should be taken not to set fire to the screening. In warm weather, crude oil, kerosene, or chloride of lime should be sprinkled into the pits at intervals in order to discourage the approach of flies. When the pits are filled to within two feet of the surface they should be filled in and mounded over.

If the men are allowed to urinate directly into the pit, they will soil the seats of a covered pit or foul the edges of an open one. It is, therefore, desirable to provide a separate urinal. This may be done by constructing a trough out of wood, or old tin, or any water-tight material, and draining it directly into the pit. Another method is to dig a separate shallow trench which the men may straddle, and drain it into the deep trench. This method is generally unsatisfactory. Urinal cans should be placed in the company streets at night and emptied in the morning. They should be marked by a lantern at night and disinfectants

sprinkled about the places in the morning when they are removed. If these cans are not placed conveniently near the tents, it will be found that the men will soil the ground about their tents. It is the duty of the latrine orderly to take care of the placing and removing of these cans.

It has been found by experience that it is a good plan to have a lavatory bench with basins, soap, water and some mild disinfectant at each latrine. The men should then have to wash their hands after defecation. This, of course, would prevent the spread of an intestinal disease by contact to a large extent. This would also come under the direction and orders of the latrine orderly.

In camps where men may be kept for some length of time, and where it is not considered worth while to install a water carriage system - such as a mobilization, or training camp - there are systems other than the direct burial system which may be employed. These systems can be conveniently described here.

The dry earth system, for some time employed by our soldiers in the Philippines, is an indirect burial system. A privy of some sort is built and some form of closets installed under which are placed pans or pails. The excreta are received in the pan and covered immediately with dry earth,

ashes, or lime. Dry, powdered earth is generally the most economical and satisfactory. The pan rests upon supports which must be high enough to hold it close to the seat so that the urine cannot be voided outside of it. The closet should be fitted with a self-closing cover and should be fly-tight. The contents of the pan are emptied daily and generally disposed of by burial, although it is sometimes possible to afford incineration. After each emptying the pan should be thoroughly sprinkled with disinfectant. A sketch of a dry earth closet is shown in Figure 9: A, the self-closing seat cover; B, the fly-tight trap-door; C, the pan; D, the supports for the pan.

Another method for disposal of excreta is the closet shown in Figure 10. This closet was designed by the United States Public Health Service and consists of two barrels or tanks connected by a pipe. The seat is placed on the larger of these tanks, which is filled about three-quarters full with water, any overflow being taken by the connecting pipe into the secondary, or effluent, tank. Flies and mosquitoes are kept out by means of a self-closing lid, by screening and by sprinkling the surface of the water with a little crude oil. The object of this closet is to liquify the fecal matter, reduce its volume and diminish the odors. The greatest advantage of this closet is the fact that it needs

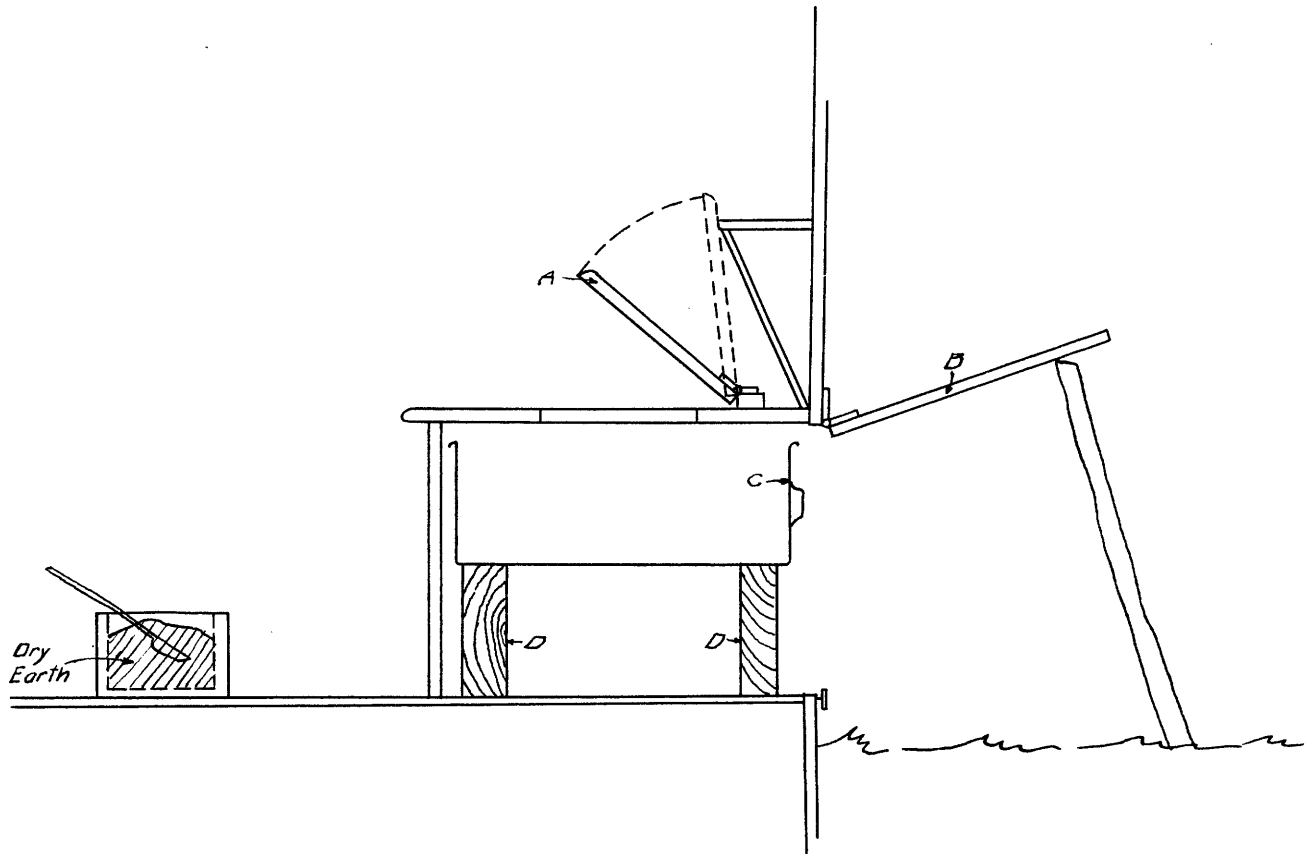

Dry Earth Closet.

FIGURE 9.

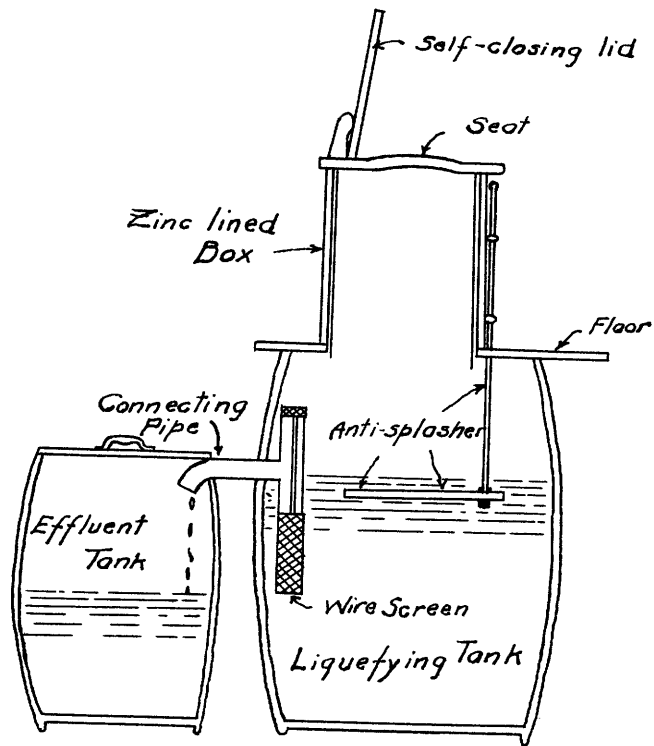

*U. S. F. H. S. Closet.
(Lumsden, Roberts, and Stiles.)*

FIGURE 10.

but little and infrequent attention, requiring emptying but seldom. The material which is removed may best be removed by discharge into an incinerator, or crematory.

The burial method, in general, is not the most desirable for the disposal of excreta, but in some cases may be the only method to be employed. The shallow trench for camps of a single night is, at the present time, the best system which presents itself for this kind of a camp. It will be shown in the next chapter that incineration is a more desirable method of disposal for camps of more permanence, and the deep trench should be abandoned for this newer and more efficient method.

CHAPTER IV.

THE DISPOSAL OF HUMAN EXCREMENT BY INCINERATION.

CHAPTER IV.

The alternative to burial is incineration, which is of such enormous importance that it demands special consideration. "The ideal method of disposal of excreta is by incineration." (Havard). By burning the necessity for disinfectants is done away with. The residuum of combustion is so small as to be negligible and necessitates no further care or disposal. Incineration can be used under any conditions of climate and at any season of the year without inconvenience. It disposes of these matters, when properly employed, with less offence than any other system. In active service this method obviates so many dangers and difficulties that it should be employed whenever possible. Keefer says, "The complete destruction of excreta by fire is the ideal method for the disposal of these unpleasant and dangerous wastes."

There are many various types of incinerators in use in our army to-day, many of which have been found to be highly efficient. The essentials necessary for successful operation of these incinerators are chiefly, constant and careful attention, and plenty of fuel. Incineration may become, if carelessly performed, very obnoxious and offensive. A slow fire, or failure to utilize the auxiliary combustion chamber, upon which some types of incin-

erators depend for the destruction of the offensive gases, may result in the dissemination of offensive odors all over the camp.

In the design of incinerators many things must be taken into consideration. A short review of some of these may not be amiss here. To begin with it must be realized that the materials to be dealt with are largely all moist and sufficient heat and surface must be supplied to evaporate the fluids before actual combustion can take place. The soldier living under ordinary camp conditions passes the following daily averages of

Faeces, $4 \frac{1}{2}$ ozs., of which 3 ozs. is water, and

"Defaecation urine," (urine passed with and not conveniently separated from faeces), 5 ozs. Thus the total liquids upon the pans amounts to 8 ounces per head per day. It has been shown that the amount of liquid to be evaporated for a small unit, say a company, cannot be satisfactorily disposed of by evaporation from bulk surfaces. A body of liquid maintained at 80° C. for twenty-four hours will lose only 6 gallons per square foot of surface.

In many instances cylinders have been provided for fluid evaporators. This will not only be unable to evaporate a sufficient volume of liquid, but will cause considerable trouble by foaming. It should be remembered that the surface tension of

urine is very high and in case the liquid boils in one of these cylindrical containers, it will froth over even though it be but a third full. In incinerators which would make use of such a device, the heat necessary is great and the boiling of such tanks involves a waste of fuel by the escape of heat up the flue.

Another method of disposing of these liquids is to soak them up in a "matrix" which is combustible. Sawdust is the best of these, for although its caloric value is low, its absorbent value is about 5; i. e., it will absorb five times its weight of fluid.

There are two main types of incineration - the open and the closed. The open type has been used more frequently in our army for the incineration of garbage and refuse and several forms of this type are discussed in the next chapter. They are, in general, not suitable for the incineration of excrement although in some case they have been used for this purpose.

The closed type has been made in various sizes and shapes depending upon the amount of excrement to be cared for and the degree of permanency of the camp in which they are to be used. There are both portable and fixed forms, although the latter

have generally been the more reliable. The great objection to the portable forms is their weight and in some cases this has been made as low as possible. In the European War motor trucks have been used extensively for all sorts of purposes and generally accompany moving commands. An incinerator of some approved type, such as the Harris, could be easily mounted upon a truck and thus made to accompany each regiment, or in case one would not prove sufficient, two or even three trucks might be thus fitted. Oil, forced in by blowers using compressed air could be used for fuel and with much greater efficiency than wood. Such an arrangement would be far better than any method now employed in our army.

To show briefly the great advantage of using oil in place of wood for the combustion chamber the following is of interest.

Dry, hard wood gives up 6,250 B. T. U's. per pound.

Gasolene gives up 18,000 B. T. U's. per pound.

Therefore, 1 pound of gasolene is equivalent to 2.88 pounds of wood.

Since 1 cord of wood weighs $128 \times 40 = 5120$ lbs.

And 1 gallon of gasolene weighs $83.3 \times 0.665 = 55.4$ lbs.

$5120 \div 2.88 = 1778 \div 55.4 = 32$ gallons.

Therefore, in heating effect

32 gallons of gasolene are equivalent to 1 cord of wood.

The more important forms of present day incinerator for use in the army, are the McCall, the Harris, the Conley, and the Quarter Master Corps types. A brief description of each, largely from Havard's "Military Hygiene," follows.

The McCall Incinerator (Figures 11 and 12).

This type of incinerator was the first to be used in our Army and is still considerably used. It is placed in a knock down building 22'6" by 15', and is somewhat unsuited for camps with no degree of permanency, inasmuch as it requires skilled labor, heavy material and time to build.

First two pits 24 inches deep are dug at right angles to each other, and lined with fire brick forming combustion chambers. On top of these are placed steel boxes. In the combustion chamber are the two pans (25) in which the excreta is incinerated and in the steel box are two wide hinged plates (10) and three narrow fixed ones (9). Upon each box is placed a wooden seat (13), in which are four holes with self-closing covers. An auxiliary combustion chamber (18) is formed at the intersection of the two pits, by a grate (21) over which is placed the smoke stack (20). To each pit a urinal (22) is connected by means of a pipe (11) and valve (26). This valve when opened allows the urine to run down on

to the pans (25) where it is evaporated, the valve only being open when the pans are fired. The urinal is ventilated by means of a pipe (22') connected to the smokestack.

For use the two hinged plates (10) are lifted and then are fastened up until the pans (25) are full. A small coke fire is now built in the auxiliary chamber (18). When this has become very hot the plates (10) are lowered, and a fire built under the pans, and their contents incinerated. The auxiliary chamber must be preheated and kept hot during incineration in order to destroy the obnoxious gases. After the solid matter has been burned the valve to the urinal is opened a small amount and the urine evaporated in the pans.

The time required for complete incineration varies from 3 to 5 hours, according to the amount in the pans and the kind and amount of wood burned. Hard wood in four foot lengths is generally employed and the sections burned out every night, or every other night, in order that they may be ready for use in the morning.

McCall Incinerator, Improved 1911 Model (Figure 13).

This model is practically the same as the older model, except that the combustion chambers have been built in steel boxes lined with asbestos.

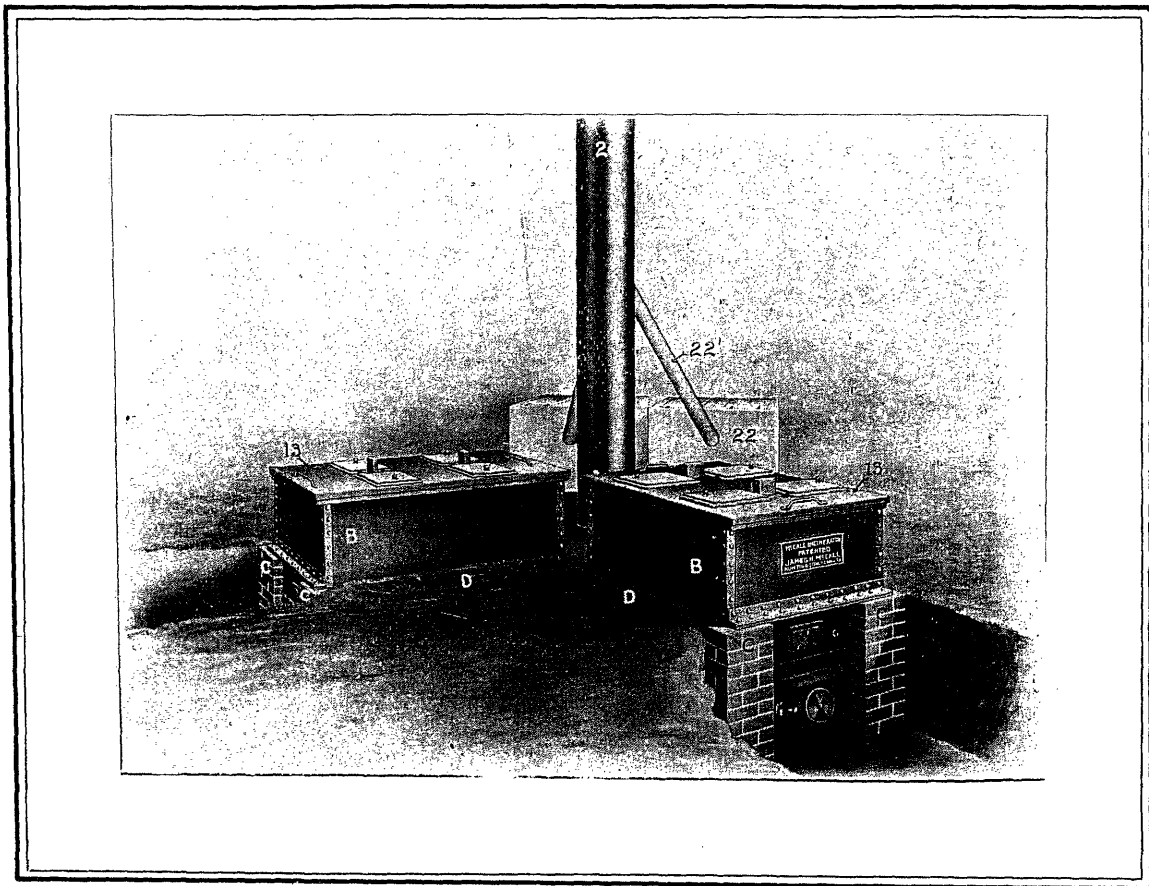

PERSPECTIVE VIEW OF THE TWO SECTIONS OF
THE MCCALL INCINERATOR.

FIGURE 11.

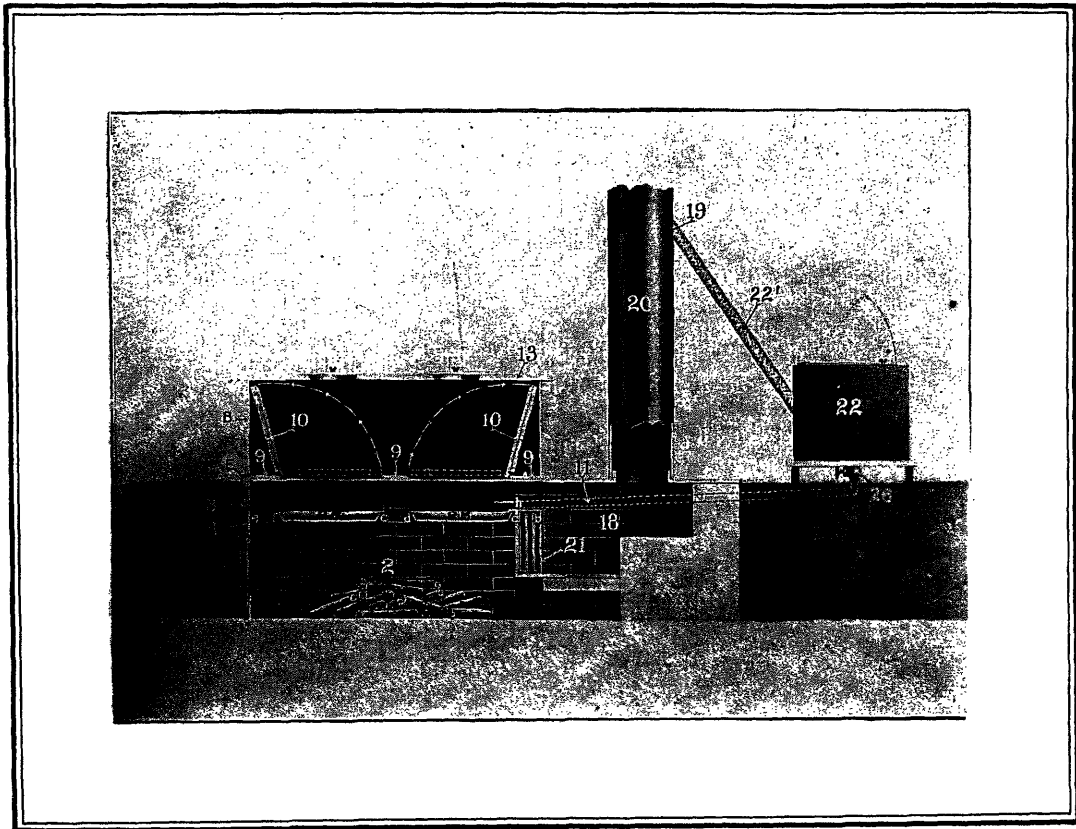

LONGITUDINAL SECTIONAL ELEVATION OF
THE McCALL INCINERATOR.

FIGURE 12.

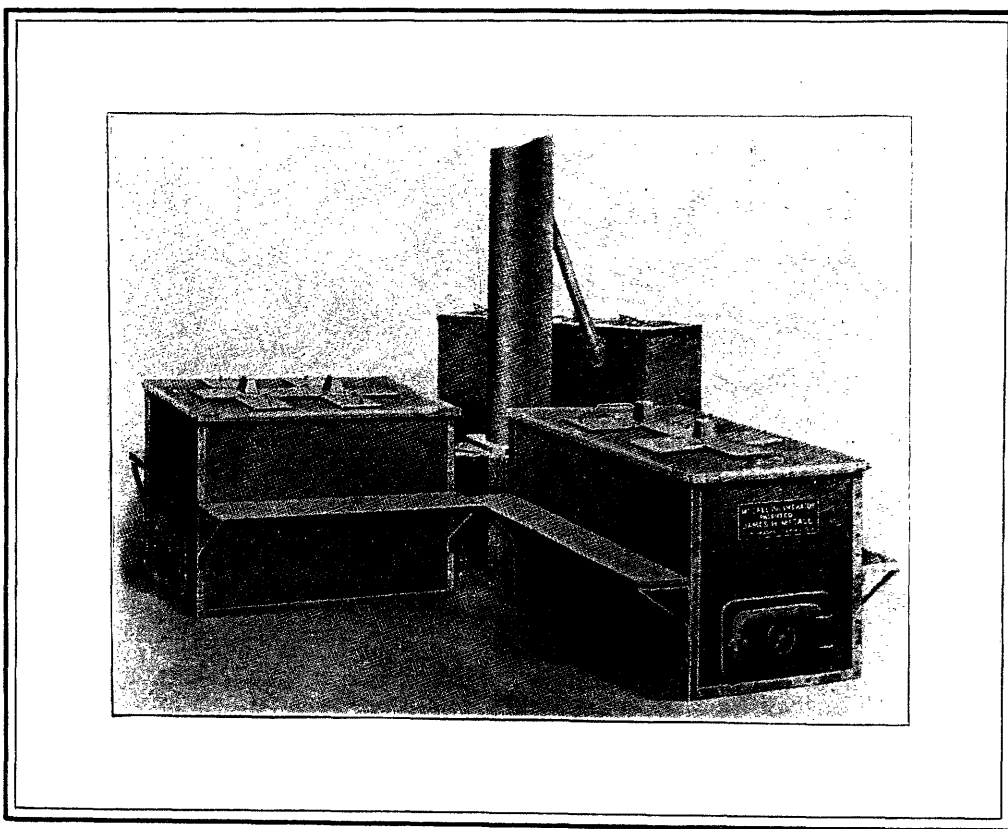

McCALL INCINERATOR, IMPROVED 1911 MODEL.

FIGURE 13.

The auxiliary chamber also has a separate opening in order to stoke the fire without interfering with the main combustion chambers.

The Harris Incinerator (Figure 14).

In this model the auxiliary combustion chamber has not been made use of and it is claimed that no offensive odors result since they are thoroughly consumed in the main combustion chamber, which runs the full length of the box. It is light, weighing but 1,000 pounds, and is assembled in one piece, having only the stack, seats and covers detachable. The box is 7 feet, 3 inches long, 21 inches high, and 36 inches wide, has eight seats and rests directly upon the ground.

The excreta fall upon a slightly convex floor, which is the roof of the fire chamber. This is fitted on each side with gutters, covered with perforated guards, into which the liquids drain. The urinal, a trough 3 feet long and extending 8 inches from the end of the box, drains directly into the gutters. It can be readily seen that the evaporation of the urine and the combustion of the solid excreta are simultaneous.

This type has a capacity of 15 men per seat and should be burned once a day. Its chief advantages are its simplicity of construction, its

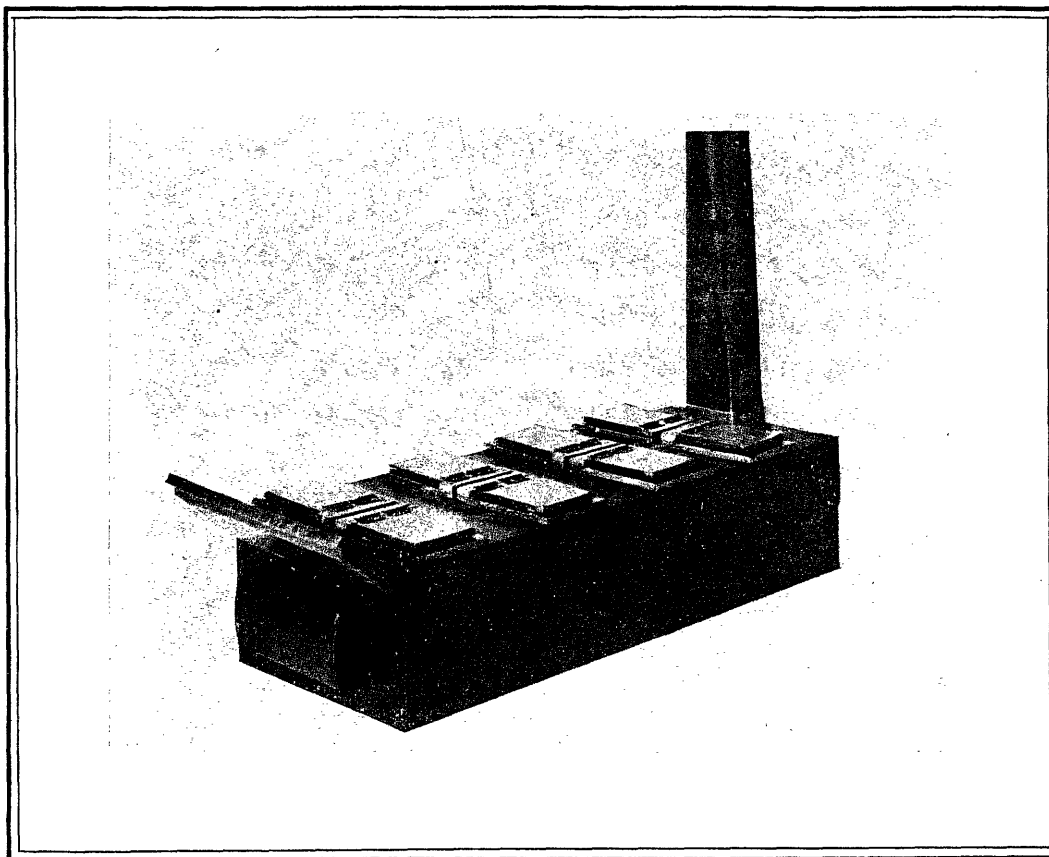

THE HARRIS INCINERATOR, MODEL 1911.

FIGURE 14.

ease of operations, its lightness and its economy. It requires less fuel per man than any other type and is lighter than any other of an equal number of seats.

The Q. M. C. Incinerator (Figure 15).

This incinerator was devised in 1911 by the Quarter-Master Corps of our Army and has special features worth notice. It is 4 feet long, 30 $\frac{1}{2}$ inches wide and 26 inches high; it is fairly light, weighing about 1,000 pounds fully equipped, although it has but four seats. The top consists of four cast iron panels with oval holes and lids to fit. Over these openings are placed the seats which are self-closing and fitted with perforated, gauze-covered lids. When set up in position, from the top down, are a segmented grate, a drip pan and a charcoal basket-burner. A urinal, with self-closing cover, is attached on either side of the smoke stack to which it is vented with a small pipe. Another pipe connects the urinal to the drip pan.

The charcoal burner is kept burning all the time and therefore the urine and such fecal matter as passes through the bars of the segmented grate are evaporated constantly. All drafts are kept closed so that the air is forced down through the perforations in the seat covers, thus preventing heat and

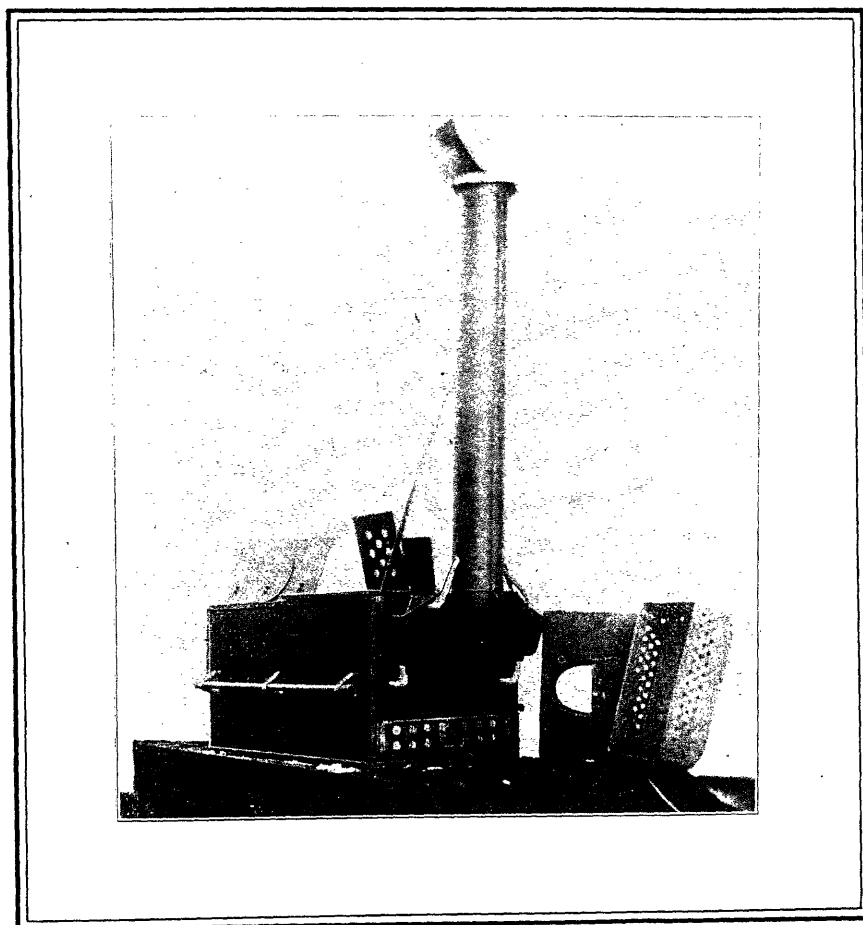

THE Q. M. C. INCINERATOR, 1911 MODEL.

FIGURE 15.

odors from escaping. Care is necessary to keep from maintaining this fire too hot so as to be uncomfortable for the men using the seats.

At night the basket-burner and wooden seats are removed, the lids placed upon the cast iron panels, drafts opened and a wood fire built in the combustion chamber. If the pan has any matters needing incineration, it can be left in until this is accomplished, when it should be removed. It is possible, though not advisable, to use this incinerator for garbage disposal.

The Conley Incinerator (Figure 16).

This form of incinerator is somewhat similar to the McCall type, for it has two or more sections connected to a common flue, each section having an auxiliary combustion chamber, and connected urinals. Each section is 63 inches long, 27 inches wide, and 27 inches deep, has four seats and a separate urinal. In each are two sets of pans connected to a crank fastened to a projecting lug on the outside. There are two longitudinal pans in the upper set and five transverse ones on the lower set. The fire thus dries the material on the upper pans to some extent, when it is dumped, by turning the crank, into the pans below, where it is still further dried and finally turned into the fire itself and thus serves

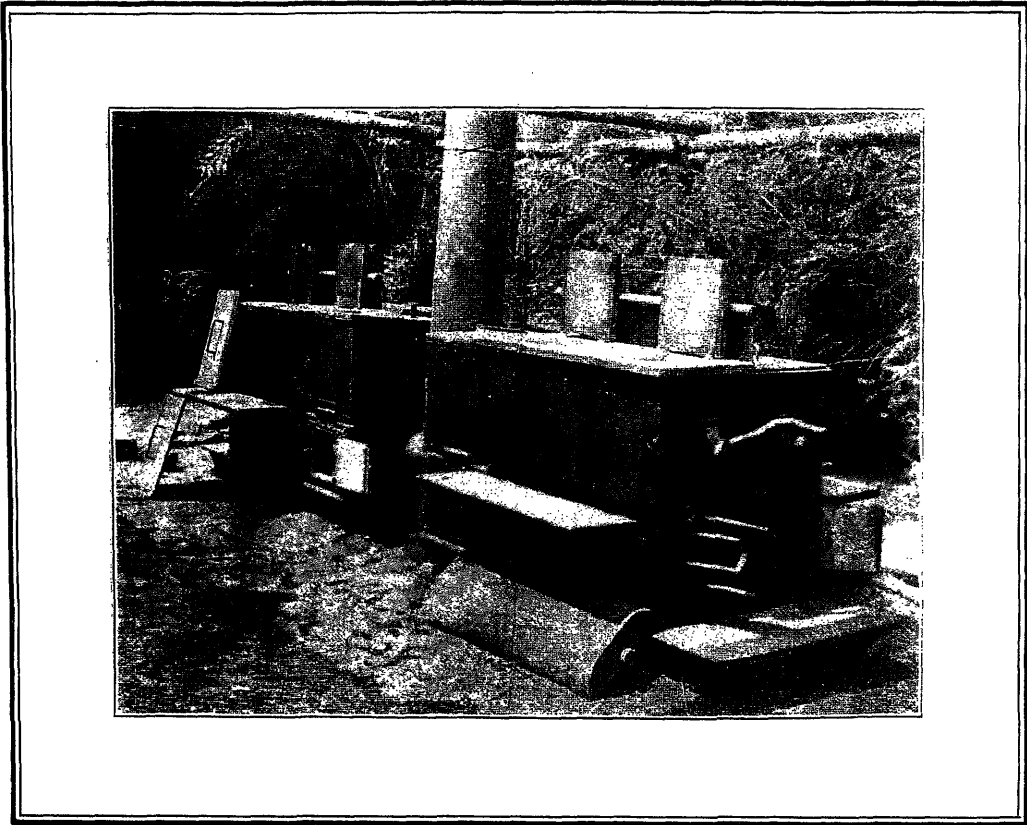

THE CONLEY FIELD INCINERATOR.

FIGURE 16.

as fuel to dry the following "dose." The urinals have separate evaporation pans. In the new models there are three separate draft systems and odors are completely done away with. This type is used for both excreta and garbage, weighs (each section) 1,500 pounds and can be easily set up in fifteen minutes.

The English field incinerators are not provided with seats, but are used for excreta disposal, the excreta being brought to the incinerator in tubs and dumped in. A sketch, from "Sanitation in War" of such a destructor is shown in Figure 17.

There has been a growing tendency recently to use these incinerators for both garbage and liquid wastes as well as excreta, and some designers have been developing their models upon this idea. Such combination is, however, scarcely desirable and cannot be expected to yield the best results. The men must of necessity visit the incinerator sheds every day and it would not be well to make these garbage pens as well. Also garbage and excreta require somewhat different treatment and could be more conveniently disposed of separately. Appliances constructed solely for one single purpose can usually accomplish it more perfectly and economically than if designed for several purposes.

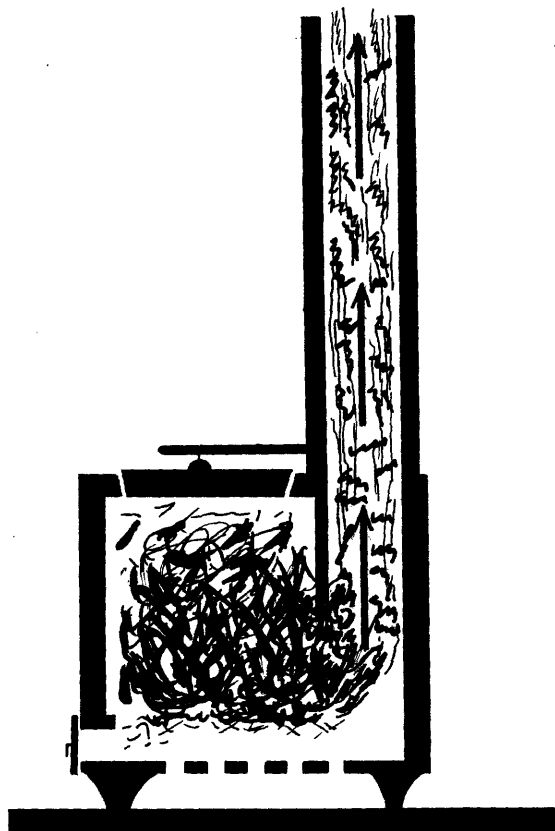

BRITISH FIELD DESTRUCTOR.

FIGURE 17.

Incineration of human excrement is, then, the ideal method of disposal for military camps. Although it is used but slightly in our army now, there is an increasing tendency upon the part of the officers to use this method of disposal. The old deep trench is being abandoned for this newer, more expensive, but more efficient, method of excreta disposal.

CHAPTER V.

THE DISPOSAL OF DRY RUBBISH, GARBAGE, WASTE WATERS, ETC.

CHAPTER V.

The disposal of garbage, dry refuse, kitchen wastes, etc., can be effected by burning. Of necessity the garbage and dry refuse which collects in a military camp is of considerable amount and of some variety. The garbage is both liquid and solid and, as it putrefies rapidly, the quicker it is disposed of the better.

In times past garbage was placed in cans near the kitchens and then these cans were collected in wagons and carried to a large crematory where they were burned. This had many disadvantages inasmuch as the cans would be filled to the top and, in their transit across the camp, their liquid contents would very generally slop over, leaving a trail evil smelling, fly attracting material. This led to the so-called "excavator" wagon, which was in reality a large tank mounted on wheels with a hand pump attachment. The liquid slops would be pumped from their containers into this wagon and then taken to the place of disposal. Although this obviated, to a large extent, the slopping, other objections were found. The chief of these was the frequent breaking of the pump apparatus. A system was then devised whereby each mess disposes of its own garbage promptly, namely, by crematories built near each kitchen.

There are many various types of crematories

and incinerators for garbage disposal, but in each case it is advisable to have the cooks tend to the disposal of their own garbage. The liquid garbage is of course the hardest to dispose of by incineration, and, if the cooks have charge of the disposal of these, they will be more careful of their accumulation and will endeavor to keep the amount as low as possible.

Some of the more important forms of garbage crematories and incinerators are as follows:-

Rock Pile Crematory (Figure 18).

This type of crematory can be very cheaply constructed if rock is available on the ground, and is suitable for a camp of about 2,500 persons. It is constructed as follows: A circular pit is dug, 3 feet in depth and 15 feet in diameter. The bottom is covered with loose stones to a depth of about 16 inches. Upon this is built a circular wall of rocks to a height of 1 foot above the original ground line and the excavated earth around the wall packed down tightly so as to form a gradually sloping approach. The object of this is to prevent surface waters from running into the pit. A pyramid of large stones, 4 or 5 feet high, is built in the center to provide a central draft. Upon emptying the garbage into this type of crematory, the heat of the

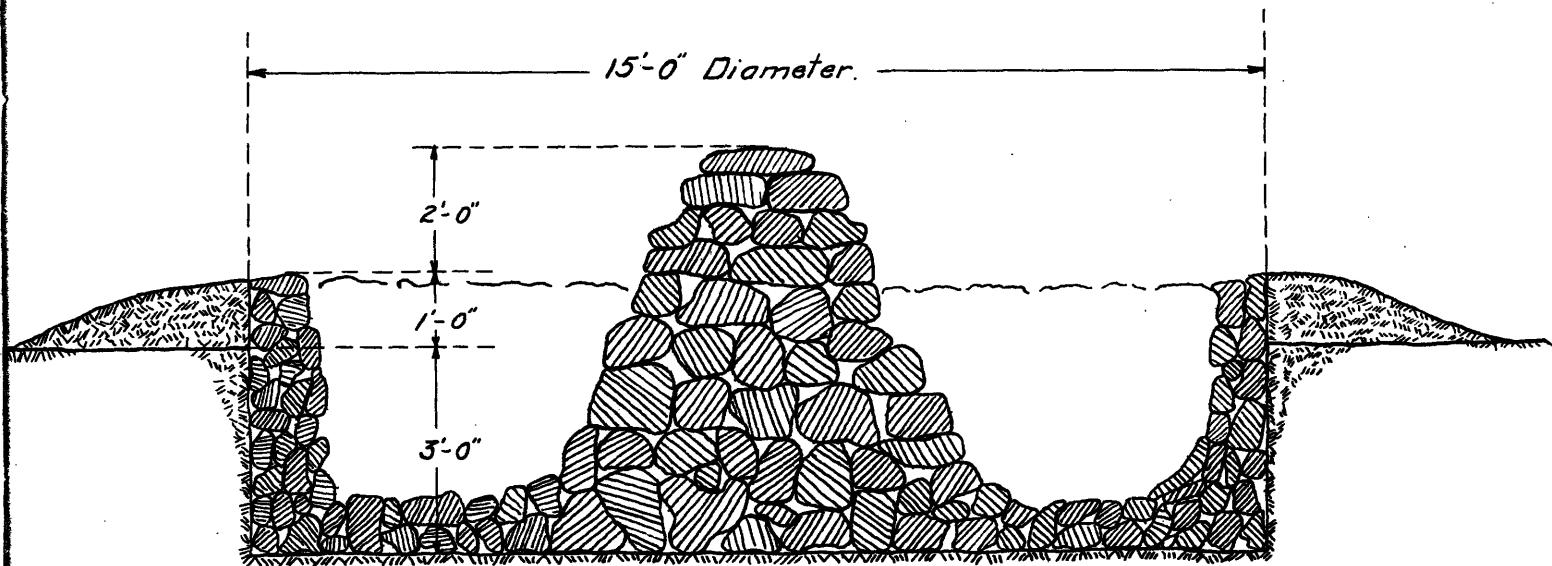

Rock Pile Crematory.

FIGURE 18.

bottom stones evaporates the liquid slops, while the solids are soon consumed as fuel for the fire.

Barrel and Trench Type (Figures 19 and 20).

In Figure 19 is shown the barrel type of crematory and in Figure 20 the barrel and trench type. The two are essentially similar, the latter being somewhat more efficient in the destruction of garbage. Both can be built for little or no cost and will be suitable for a camp of from 125 to 100 persons. The barrel and trench type is constructed as follows:- Two trenches 10 or 12 inches wide are dug for a length of 10 feet each bisecting each other. At the point of bisection the trench should be 15 to 18 inches deep, gradually shallowing from this point to their origin. Four boards are placed over the point of bisection of the trenches to support an ordinary flour or sugar barrel. Sods of earth should then be piled around the barrel and packed tightly up to the top of the barrel. If sods are not obtainable clay may be used. A fire is then built in the trench under the barrel and when the barrel is burned out, a hard cone of earth or clay will be left.

In operating this type of crematory one trench opening near the cone is left uncovered, ac-

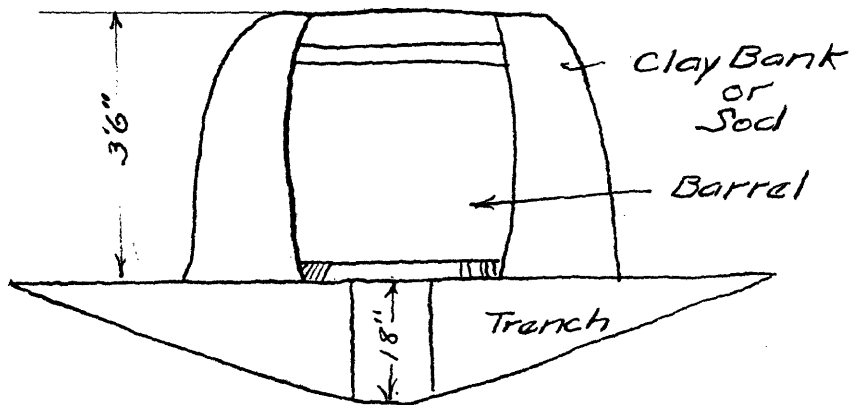

Section.

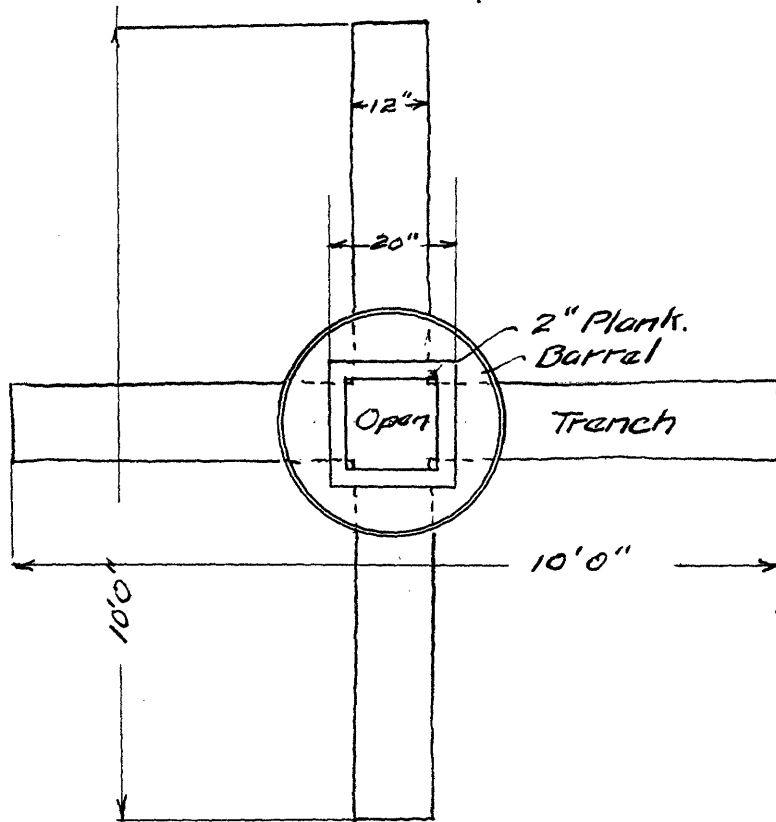

Plan.

BARREL AND TRENCH CREMATORY.

FIGURE 19.

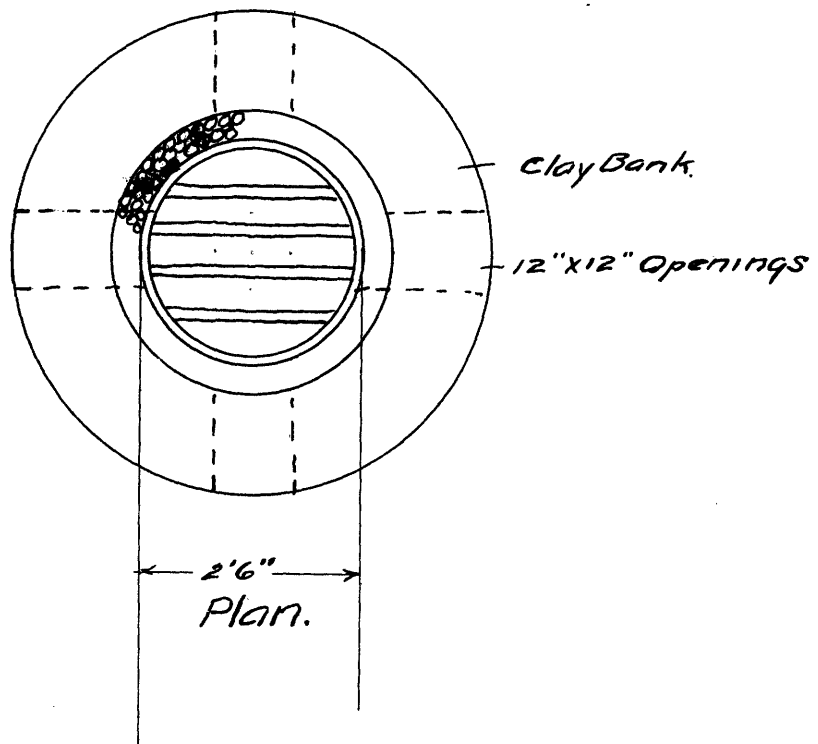
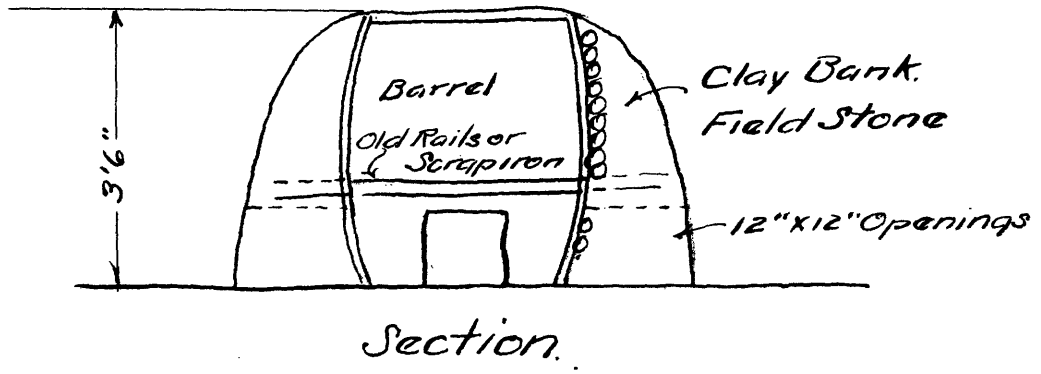

BARREL CREMATORY.

FIGURE 20.

ording to the direction of the wind and the other three covered up. Having four openings a draft can be provided no matter what the direction of the wind. The fuel and garbage are dumped directly into the top of the cone.

Pit Crematory (See Figure 21).

This crematory is suitable for a camp of 250 people, but in general is not so satisfactory as the types described above. It is constructed by digging a pit 5 by 2 $\frac{1}{2}$ feet by 6 inches deep at one end and 12 inches deep at the other. The pit is lined with field stones and the excavated earth piled around it. The fire is built upon the stones and the garbage poured in at the shallow end, the hot stones evaporating the liquids and the solids being burned by the fire.

Garbage disposal with marching troops is of less importance, although it should be disposed of. A small hole 2 feet in diameter and 2 feet deep can be dug near the field kitchen and the garbage, both solid and liquid, thrown therein. Before leaving, this hole should be filled in with earth and mounded over.

Dry refuse should be collected and placed in boxes or barrels placed around the camp, which should be emptied daily into the camp crematory.

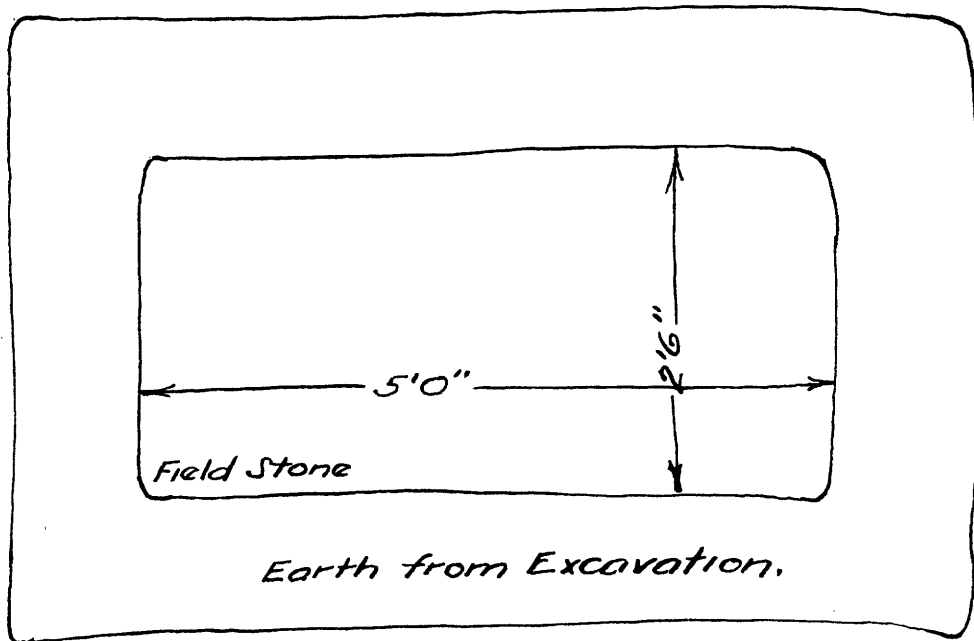
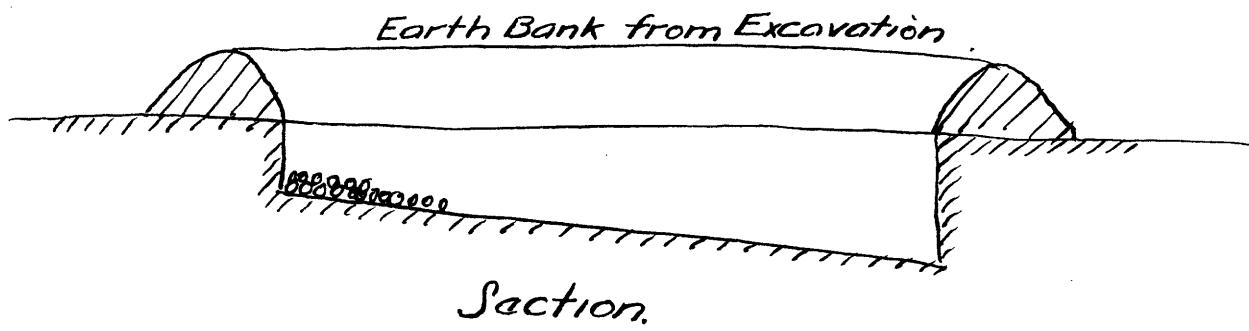

Plan.

PIT CREMATORY.

FIGURE 21.

Waste paper, boxes, pieces of cloth, etc., should not be allowed to blow about the camp, but should be picked up and placed in one of the receptacles.

Sullage water, water from kitchen sinks and ablution places should be cared for and properly disposed of. The following is a very good scheme, taken from Poore's "Camp Sanitation":- (Figure 22).

A trench 18 inches wide and 18 inches deep is dug from the kitchen, or bathing place, for about 18 or 20 feet. This is filled with all sorts of coarse rubble, broken stone, etc., and a pile of bricks built in the trench up to the level of the ground, spaced about every 6 feet. Upon these are placed cast iron perforated plates. At the head of the trench is placed any large old galvanized iron vessel with an outlet at the bottom and filled with broken clinkers varying in size from peas at the bottom to walnuts at the top. This acts as a filter, partly mechanically and partly by virtue of the growth of bacteria on the surface of the broken clinkers. In this is placed a basket filled with straw and the water is run on to this. The straw removes a large amount of the grease in the water and it is necessary to remove the basket and burn it and its contents, replacing it with a new basket filled with fresh straw.

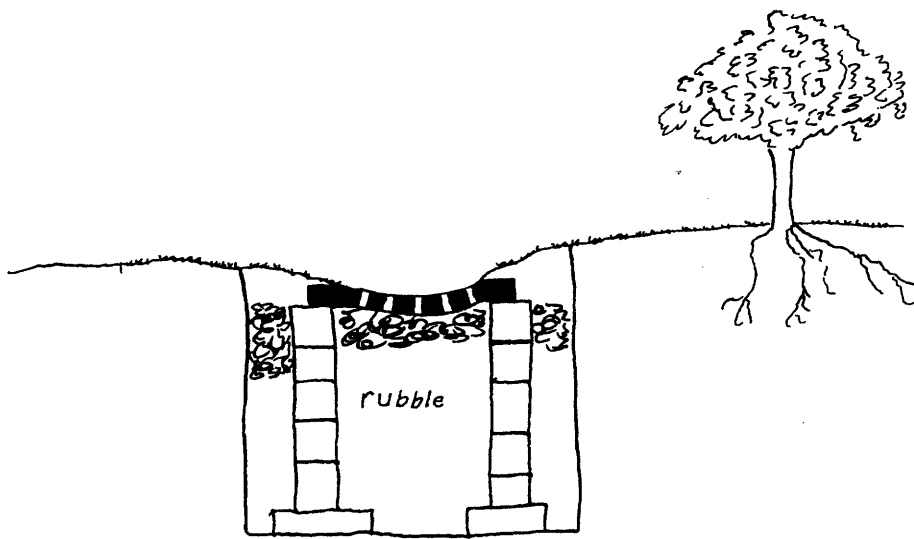
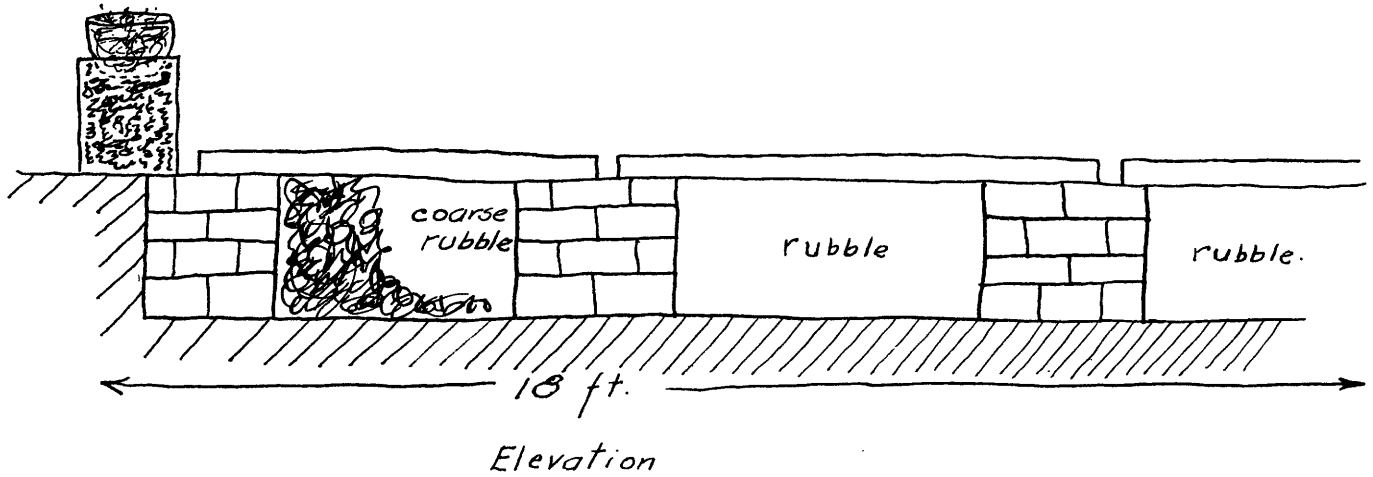

Trench for Stop water.

FIGURE 32.

The water running through the filter runs along the filtration gutter and through the perforations therein, all getting into the trench before any water reaches the end of the gutter.

Animal manure should be collected at least once a day and taken to a burning place. A very convenient method is to set up a large grid, building a fire underneath and throw the manure upon it, the drying refuse later serving as fuel for its own destruction.

The camp wastes treated in this chapter are of minor importance. Their relation to disease can only be indirect, but a prompt and efficient disposal of them eliminates any possibility of danger and what is very important produces a clean, tidy and pleasant camp.

BIBLIOGRAPHY.

BIBLIOGRAPHY.

1914. Keefer, Military Hygiene and Sanitation,
Textbook of, Saunders, Philadelphia,
pp. 305.
1914. Havard, Colonel Valery, Military Hygiene,
Wood, New York.
1901. Munson, Edw. L., Military Hygiene, N. Y.
1916. Lelean, Maj. P. S., Sanitation in War. J.
& A. Churchill, London.
1910. Caldwell, R., Military Hygiene, N. Y.
1915. Ashburn, P. M., The Elements of Military Hy-
giene, Houghton Mifflin, Boston.
1916. U. S. Army, Manual for the Medical Department,
U. S. Army.
1914. U. S. Army. Drill Regulations and Service
Manual for Sanitary Troops, U. S. Army.
1914. U. S. Army. Field Service Regulations. Gov-
ernment Printing Office, Washington.
1914. Wilson, James S., Field Sanitation; a manual
for non-commissioned officers. Banta,
Menasha, Wis.

1916. Rosenau, Dr. M. J., Preventive Medicine and Hygiene--Military Hygiene, pp. 1177-1210, Appleton, N. Y.
1916. Mason, Dr. Charles F., Handbook for the Hospital Corps, Wood, N. Y.
1911. Knox, Military Sanitation and Hygiene. Baillière, Tyndall and Cox, London.
- Poore, G. V., Colonial and Camp Sanitation, Longmans, Green and Co., London.
1904. Report on the Origin and Spread of Typhoid Fever in U. S. Military Camps during the Spanish War of 1898. Washington.
- Soil Pollution and its Relation to Hookworm Disease and Typhoid Fever. By Ch. Wardwell Stiles. Pub. Health Reports, Vol. XXIV, No. 40, Oct. 1, 1909.
- Sanitation in Construction Camps of the Catskill Aqueduct. Eng. Record, Vol. LXI, No. 14 (Apr. 2, 1910), pg. 443.
- The Contractor's Camp at the Ashokan Reservoir. Eng. Record, Vol. LXIII, No. 12 (Mar. 25, 1911), pg. 339.

- Construction Camps in Great Britain. Eng.
Record, Volume LXI, No. 8 (Feb. 19,
1910), pg. 217.
- Sanitary Problems on the Catskill Aqueduct
Work. Eng. Record, Vol. 63, No. 19
(May 6, 1911), pg. 500.
- Sanitation with British Expeditionary Forces
in France. By N. W. Hoskins. London
Surveyor Dec. 8 and Dec. 15, pgs. 526
and 552, respectively.
- Sanitation in billets and camps by A. White.
Lancet London i, 41: 95.
- Field Sanitation by E. B. Pike. Journal Royal
Army Mech. Corps. London, XXVI, pgs.
330-348.
- Camp Sanitation by H. R. Kenwood, J. Roy
Ian. Inst. London, Vol. XXVI, pgs. 416-
425. Same Med. Mag. London, Vol. XXIV,
pgs. 390-395.
- Thesis by G. T. Palmer, "Excrement Disposal,
A Problem of the Unsewered Community."
- Thesis by G. A. Tobey, "Camp Sanitation."

With the 22nd Corps of Engineers at Camp

Whitman, by R. K. Tomlin, Jr., Eng.

Rec., Vol. 74, July 1, 1916, pgs. 4-9.

Construction Camp Garbage and Refuse Incin-

erators. Eng. and Contr., Vol. 44, Sept.

1, 1915, pgs. 163-165.

1906. The Real Triumph of Japan, Seaman, Appleton
& Co.